



# STORMWATER MANAGEMENT PLAN

**CONSTITUTION STORAGE  
PCD FILING NO.: PPR-22-024**

**STORMWATER PERMIT # COR\_\_\_\_\_**  
**CERTIFICATION # \_\_\_\_\_**

***Owner/Developer:***

Johnson Development Associates,  
Inc.  
100 Dunbar Street, Suite 400  
Spartanburg, SC 29306

***SWMP Preparer:***

Galloway & Company, Inc.  
1155 Kelly Johnson Blvd., Suite 305  
Colorado Springs, CO 80918

***Contractor:***

***SWMP Administrator / Qualified  
Stormwater Manager:***

***Date:***

Prepared: July 21, 2023

***SWMP Location:***

On-Site (Copy) and Johnson  
Development Associates (Original)



## TABLE OF CONTENTS

### SWMP REPORT REVISION LOG

I. PROJECT DESCRIPTION .....	4
II. PHASING AND PROPOSE CONSTRUCTION SEQUENCE .....	4
III. FINAL STABILIZATION .....	5
IV. PRE-DEVELOPMENT CONDITIONS & SOILS.....	6
V. DESCRIPTION OF POTENTIAL POLLUTANTS.....	7
VI. AREAS AND VOLUMES.....	11
VII. APPROPRIATE CONTROLS AND MEASURES.....	11
VIII. MATERIALS HANDLING AND SPILL PREVENTION .....	14
X. RECEIVING WATERS .....	17
IX. INSPECTION AND RECORD KEEPING .....	17

### Appendices:

- A. Vicinity Map
- B. Soils Map
- C. FEMA Map
- D. GEC Plan
- E. BMP Details
- F. ESQCP

## SWMP REPORT REVISION LOG

REVISION #	DATE	BY	COMMENTS
1.			
2.			
3.			
4.			
5.			
6.			
7.			
8.			
9.			
10.			
11.			
12.			
13.			

## **I. PROJECT DESCRIPTION**

### **LOCATION**

Constitution Storage is a commercial development located in the Cimarron Hills area of El Paso County, Colorado. The site is located in a portion of Section 05, Township 14 South, Range 65 West of the 6th Principal Meridian, County of El Paso, State of Colorado. The subject property is bounded by Constitution Avenue to the north, Canada Drive to the east, Peterson Road to the west, and existing Northcrest Filing No. 3 residential development to the south.

### **LEGAL DESCRIPTION**

The legal description of Constitution Storage is:

LOT 1, EIGHT LINE SUBDIVISION

### **DESCRIPTION OF PROPERTY**

The project site consists of approximately 3.716 acres and includes 929 storage units and is comprised of undeveloped land covered sparsely by native grasses, trees, and weeds

### **CONSTRUCTION ACTIVITY**

Construction activities include but are not limited to infrastructure to support the proposed commercial development includes grading, street pavement, stormwater conveyance (pipes, inlets, junction boxes, etc.), potable water mains, sanitary sewer mains and stormwater quality ponds. Construction will commence with preliminary over lot grading followed by utility installation. Construction will be completed with final stabilization including asphalt pavement, seeding (or sod) and sidewalks.

Temporary stabilization measures (silt fence) will be installed prior to beginning construction. During construction, temporary stabilization measures, including inlet protection, will be utilized to control stormwater runoff. Once final stabilization is achieved, temporary erosion control measures will be removed.

## **II. PHASING AND PROPOSED CONSTRUCTION SEQUENCE**

### **PHASING**

Construction activities will be completed in three phases, Initial, interim and final. Initial phase includes the installation of perimeter controls such as silt fence around the entire project's Limit of Disturbance area, and curb socks at existing gutter flowline. Interim phase includes the installation of temporary sediment controls as construction progresses. Refer to the provided phasing table on the Grading and Erosion Control Plans. The final phase will be completed once the site is stabilized and all temporary measures are removed. The Final Grading and Erosion Control Plans will include the initial, interim and final erosion control measures.

### **CONSTRUCTION DOCUMENTATION**

Construction drawings are provided with this document showing each of these phases and are intended to be a “living” document used by the SWMP Manager to document construction activities. See section IX “Inspection and Record Keeping” for additional information.

### **PROPOSED SEQUENCE FOR MAJOR CONSTRUCTION ACTIVITIES**

Construction for the development of this project is currently projected to begin in Spring of 2023. It is estimated that construction activities will be completed by Fall of 2023. Final stabilization is expected in the fall of 2023. The anticipated sequence of construction is as follows:

#### **Initial:**

1. Installation of perimeter silt fence as shown on the grading and erosion control plans.
2. Placement of inlet protection erosion control measures along existing roadways.
3. Placement of curb socks along existing roadways.
4. Install Vehicle Tracking Control at entrances as shown on the grading and erosion control plans.

#### **Interim:**

5. Site Clearing/Grubbing and topsoil stockpiling.
6. Construct Stabilized Staging Area as shown on the grading and erosion control plans.
7. Construct temporary sediment basins as necessary.
8. Rough grading of the site.
9. Placement of straw bale barriers along internal roadways.
10. Placement of check dams along drainage swales
11. Construct underground water/sewer/storm.

#### **Final:**

12. Construct curb/gutter and pavement.
13. Final stabilize areas outside of ROW.
14. Final seeding and mulching of the site.
15. Construct gas/electric/cable/phone in the ROW areas.
16. Final stabilize ROW.
17. Final erosion control measures as areas are completed. (Final BMP's)
18. Remove construction BMP's

See Section VI “Areas and Volumes” for information on anticipated disturbed area and grading volumes.

## **III. FINAL STABILIZATION**

Final site stabilization will be achieved when all final landscaping and paving is complete and when vegetation density is greater than 70 percent of pre-disturbance density over the entire area. The remainder of the site will consist of hardscape (drives and walks) or be a part of the building footprint. All final stabilization on the site will be of a permanent nature. All temporary BMPs will be removed upon completion of construction. It is the responsibility of the contractor to remove all dirt and garbage from the site.

Permanent BMP's such as water quality ponds will be owned and maintained by Johnson Development Associates, Inc.. A single (1) water quality detention ponds will be provided with discharge pads, infiltration media, and outlet structures.

## IV. PRE-DEVELOPMENT CONDITIONS & SOILS

### FLOODWAY

According to the current FEMA Flood Insurance Rate Map (FIRM) Panel No. 08041C0752 G, dated December 7, 2018 (See Appendix for the FEMA FIRM Exhibit) this site is designated as Zone X (outside 0.2% chance of flood). The proposed commercial self-storage development is completely outside of the "regulatory floodway".

### EXISTING VEGETATION

Existing vegetation and soils were determined from in-person field site visits and existing aerial inspection from Google Earth and the United States Department of Agriculture Natural Resources Conservation Service (NRCS) Web Soil Survey. The site is currently undeveloped. Vegetation consists of native grasses/weeds and trees. Ground cover is estimated at 70% density.

### EXISTING DRAINAGE PATTERNS

The site is contained fully within one major drainage basin; the Sand Creek Drainage Basin. There are no major drainage ways within or adjacent to the site. Stormwater from this site generally drains to the southeast and southwest. The property presently discharges via sheet flow along the southern property line onto the adjacent Lot 2, Eight Line Subdivision.

### EXISTING SLOPES

The site generally drains from north to the southwest and southeast with average slopes of 2%.

### EXISTING SOIL TYPES

Soil data for Bent Grass Residential was obtained from the United States Department of Agriculture Natural Resources Conservation Service (NRCS) Web Soil Survey.

The following table summarizes the characteristics of the soil type:

Soil	Hydro Group	Shrink/Swell Potential	Permeability		Surface Runoff Potential	Erosion Hazard
97-Truckton sandy loam, 3 to 9 percent	A	Low	High		Very Low	Slight

The existing soil types have a slight potential for erosion which can be mitigated by employing appropriate downstream construction BMP's before/during/after construction to limit potential impacts to stormwater discharges. The potential impacts are sediment discharge onto the existing adjacent properties. Sediment should not be allowed to leave the project site and can be

mitigated by constructing small temporary sediment traps at low points prior to discharge onto the adjacent properties and existing curb flowlines at Peterson Rd & Canada Dr. Potential impacts from runoff flowing onto the existing wet weather conveyance will be mitigated by constructing temporary sediment traps in the new pond locations and by grading the site to reduce drainage area. Based upon the location of the existing soil type and type of construction, the contractor shall employ the most appropriate method of erosion control measures based on the El Paso County/City of Colorado Springs Drainage Criteria Manual, Vol. 2 or as directed by the SWMP administrator or his representative.

More detailed soils information can be found in the SCS soils survey for El Paso County.

## **V. DESCRIPTION OF POTENTIAL POLLUTANTS**

Potential sources of sediment to stormwater runoff include earth moving and concrete activities associated with grading and landscaping.

Potential pollutants and sources, other than sediment, to stormwater runoff include Trash, debris, line transfer, Dewatering, fueling and equipment failure.

A dewatering permit is not required

Construction activities produce many different kinds of pollutants which may cause storm water contamination problems. Grading activities remove rocks, vegetation and other erosion controlling surfaces, resulting in the exposure of underlying soil to the elements. Because the soil surface is unprotected, soil and sand particles are easily picked up by wind and/or washed away by rain or other water sources.

The following sections highlight the potential sources of pollution at the Project Site and list the “Best Management” strategies that will be used to prevent migration of pollution offsite. This Project Site does not rely on control measures owned or operated by another entity. Chemical materials stored indoors or that have no reasonable chance of impacting storm water quality will not be discussed in this plan.

Materials of significance stored on the project site include:

- Sediment
- Concrete Washout
- Cement
- Trash & Debris
- Sanitary Wastes
- Fuels & Oils

### **WIND EROSION & DUST CONTROL**

Pollutant: Sediment Best Management Strategies:

- Daily inspections will occur for areas experiencing excessive winds, vehicle traffic, or precipitation events.
- Water trucks will spray down dust on the project Site as needed to not impact adjacent properties.
- Attention will be given to prevent the over-use of water in dust control operations to minimize any muddying of the surface and possible sediment transportation.

### **VEHICULAR TRANSPORT**

Pollutant: Sediment Tracking Best Management Strategies:

- Construct a stabilized construction entrance to provide ingress and egress of the site.
- Restrict access to the stabilized construction entrance.
- Fencing will be erected if problems with access control are evident.
- Maintain track out pads by fluffing up the rock material or by adding additional rock as needed.
- Inspect, sweep and clean adjacent streets where track out is evident.

### **STOCKPILES**

Pollutant: Sediment Best Management Strategies:

- Locate stockpiles clear of any water flow paths.
- Locate stockpiles within the property boundary.
- Stockpiles will have erosion control devices as needed installed around the base to prevent the migration of soil.
- Topsoil stock-piles and disturbed portions of the site where construction activity temporarily ceases for at least 14 days will be stabilized with temporary seed and mulch no later than 14 days from the last construction activity in the area.

### **GRADING, TRENCHING, EXPORT/IMPORT**

Pollutant: Sediment Best management Strategies:

- Earth moving will be minimized by the engineering balancing of the site.
- Disturbed portions of the site where construction activity temporarily ceases for at least 14 days will be stabilized with temporary seed and mulch no later than 14 days from the last construction activity in the area.
- Seed bed preparation is not required if soil is in loose condition.
- Prior to seeding, fertilizer shall be applied to each acre to be stabilized in accordance with the manufacturer's specifications.
- If required seeding areas shall be mulched with straw to a uniformed cover. The straw mulch is to be tacked into place by a disk with blades set nearly straight.
- A site-specific erosion control drawing has been developed showing the location of Best Management practices to be used during site construction.



- Where indicated on the erosion control plan, Best Management Practices will be installed.
- Material shall be in accordance with the plans and specifications and all construction shall be provided in accordance with the manufacturer's specifications.
- All BMP's will be inspected bi-weekly and cleaned/maintained as required.

#### **WASTE, RESIDUAL CONCRETE**

Pollutant: Concrete, paint, and Phosphoric Acid Best Management Strategies:

- A cleanup and washout area will be designated and posted.
- Subcontractors will be instructed on the locations and importance of the washout and cleanup areas. No on-site disposal is allowed.
- Instruct subcontractors to remove waste for which proper onsite disposal facilities are not provided back to their own facilities for ultimate transport, storage & disposal.
- Subcontractors and subcontractor employees are held responsible for improper washout.

#### **SANITARY FACILITIES, TRASH CONTAINERS & LITTERING**

Pollutant: Bacteria, Ammonia, Trash Best Management Strategies:

- Portable facilities will be regularly serviced to prevent excessive waste containment and overflow.
- Portable facilities will be located a minimum of 50 feet from state waters. They shall be adequately staked and cleaned on a weekly basis. They will be inspected daily for spills.
- All waste materials will be collected and stored in a container which will meet all local and any state solid waste management regulations.
- Trash dumpsters will be emptied prior to becoming 90% full or when debris control becomes an issue.
- Employees will be instructed on the importance of recycling and waste management and will be held responsible for improper waste management.

#### **FUELING, HAZARDOUS MATERIALS, EQUIPMENT LEAKAGE, FERTILIZER**

Pollutant: Petroleum Hydrocarbons, Ethylene Glycol, Sediment Best Management Strategies:

- MSDS sheets will be maintained in the project trailer for all onsite materials
- All dry materials such as cement will be covered and protected from rain.
- Secondary containment will be provided for stored fuel, oil, paint and any material classified as hazardous.
- Subcontractors are responsible for hazardous waste removal back to their own facilities for ultimate transportation, storage and disposal.
- Supplies will be kept onsite as necessary to control any potential spill.
- Employees will be held responsible for any illegal dumping.
- Seals will be checked by a qualified professional on all equipment and containers containing significant materials that could contribute potential pollutants and will be replaced as necessary.
- Equipment will be inspected by a qualified professional.
- Drip pans will be available for minor leaks and during fueling operations.

- Fueling nozzles, gauges, hoses, seals, and emergency shutoff valves will be inspected for leaks prior to use.
- Under no circumstances during fueling will the fueling hose/nozzle be left unattended.
- Fertilizers used will be applied only in the minimum amounts recommended by soil tests.
- Once applied, fertilizers will be worked into the soil to limit exposure to storm water.
- Stored fertilizer will be protected from exposure to precipitation and storm water runoff.

**DEWATERING** – not needed.

This shown for information only Pollutant: Sediment, Oil and/or Grease and Phosphoric Acid Best Management Strategies:

All dewatering will be filtered through rock and/or woven geo mesh fabric.

All dewatering will be tested for Pollutants per state guidelines weekly.

**CONCRETE AND ASPHALT BATCH PLANT** – not needed.

This shown for information only There are no existing batch plants located on this project site and there are no proposed batch plants in the future.

**DRILLING SLURRY FOR DRILLING PIERS.** – not needed.

This is shown for information only. No drilling slurry is allowed to be deposited onto the job site. All drilling slurry shall be collected and pumped into an on-site frac tank and shall be disposed of off-site.

There are no major potential pollutants anticipated to be used on the site.

**ADDITIONAL (NONSTRUCTURAL) BEST MANAGEMENT PRACTICES FOR SEDIMENT:**

1. Earth moving will be minimized by the engineering balancing of the site.
2. Disturbed portions of the site where construction activity temporarily ceases for at least 14 days will be stabilized with temporary seed and mulch no later than 14 days from the last construction activity in the area.
3. Seed bed preparation is not required if soil is in loose condition.
4. Prior to seeding, fertilizer shall be applied to each acre to be stabilized in accordance with the manufacturer's specifications.
5. If required seeding areas shall be mulched with straw to a uniformed cover. The straw mulch is to be tacked into place by a disk with blades set nearly straight.
6. A site-specific erosion control drawing has been developed showing the location of Best Management practices to be used during site construction.
7. Where indicated on the erosion control plan, Best Management Practices will be installed.
8. Material shall be in accordance with the plans and specifications and all construction shall be provided in accordance with the manufacturer's specifications.
9. All BMP's will be inspected bi-weekly and cleaned/maintained as required.

## **VI. AREAS AND VOLUMES**

The site consists of 3.716 acres. All 3.716 acres is expected to be disturbed for the proposed Early Grading and Erosion Control Plan.

The unadjusted cut and fill quantities as of the writing of this report are listed below:

Cut Volume = 5,723 Cubic Yards

Fill Volume = 15,688 Cubic Yards

Net Volume = 9,966 Cubic Yards (Fill)

Note: The Total disturbed area shall be updated on the SWMP as changes occur.

## **VII. APPROPRIATE CONTROLS AND MEASURES**

Also refer to attached Erosion and Sediment Control notes and plans included in the site plans.

### **MINIMIZE DISTURBED AREA AND PROTECT NATURAL FEATURES AND SOIL**

All work will occur inside the limits of construction per the Erosion Control Site Plan.

**PHASE CONSTRUCTION ACTIVITY** The sequence for the installation and removal of erosion and sediment control measures is as follows: Perimeter control measures (silt barriers and fencing) installed at designated areas as noted on the site plans (Exhibit 1), cleaning of street surfaces during construction if applicable, site grading, installation of utilities, paving final and grading, installation of sod or other vegetation, removal of temporary practices and perimeter controls, and site cleanup.

### **CONTROL STORMWATER FLOWING ONTO AND THROUGH THE PROJECT**

Offsite stormwater flows are contained onsite for this project site as the project area is bounded to the north by Constitution Ave, to the east by Canada Dr, and to the west by Peterson Rd. Developed runoff generated on-site will be directed to facilities that begin as temporary sediment traps (TST) and will be constructed to be full spectrum detention facilities (FSD) as construction progress for the project site. No sediment will enter the downstream receiving waters into the Sand Creek Basin.

### **STABILIZE SOILS**

No disturbed areas, which are not actively being worked, shall remain denuded for more than 14 calendar days, unless otherwise authorized by the SWMP administrator. Temporary cover by seeding or mulching should be provided on areas which will be exposed for a period greater than 14 days before permanent stabilization can be achieved. Permanent cover should be provided on all areas as soon as possible, by means of seeding and mulching, straw or hay mulch is required. All soil stockpiles and borrow areas must protected with silt fence within 14 days after grading. All slopes within the project limits that are found to be eroding excessively within two years of permanent stabilization shall be provided additional slope stabilization methods such as seeding and mulching or erosion control blanket. Water is to be used for dust control. The Contractor will prevent the release of this water and any sediment it may carry from the construction site.

### **PROTECT SLOPES**

Temporary stabilization will include the installation of silt fences on level contours spaces at 10-20 foot intervals. Slopes will be seeded and covered with hay, straw or erosion control blankets on slopes greater than 3:1, as needed to provide for temporary stabilization until vegetation is permanently established. All slopes within the project limits that are found to be eroding excessively within two years of permanent stabilization shall be provided additional slope stabilization methods such as seeding and mulching. Where slopes exceed 3:1, erosion control blankets (per specification requirements) will be utilized for final stabilization.

### **PROTECT STORM DRAIN INLETS**

Inlet protection will be installed as soon as storm drain inlets are installed and before land disturbance activities begin adjacent to the proposed storm inlets. At the Contractor's discretion, additional temporary erosion control practices to include rock bags/socks and sandbag barriers may be installed to prevent sediment transport. Inlet protection will include rock bags/socks, erosion logs, and curb inlet sediment filters where an overflow capacity is necessary to prevent excessive ponding in front of the curb inlet. Concrete block and wire screen inlet protection detail, if used, will be added to Appendix prior to installation. This measure would be used where heavy flows are expected and where an overflow capacity is necessary to prevent excessive ponding around the inlet. Inlet protection devices will be inspected at regular intervals and accumulated sediment will be removed as needed.

### **ESTABLISH PERIMETER CONTROLS AND SEDIMENT BARRIERS**

Temporary stabilization will include the installation of silt fences on the downslope perimeter of project area. The silt fence will be trenched in on the uphill side 6 inches deep and 6 inches wide, as detailed in the silt fence exhibit. Sediment will be removed when it reaches 1/3 the height of the fence. Silt fence will be inspected and replaced or repaired as needed.

### **RETAIN SEDIMENT ON-SITE**

Temporary sediment traps shall be installed to detain sediment laden runoff from small watersheds for a period long enough to allow sediment to settle before discharge onto receiving adjacent properties. For small drainage locations, smaller sediment traps should be utilized. At a minimum, silt fences, vegetative buffer strips or equivalent sediment source controls are required for all down-slope boundaries (and for those side slope boundaries deemed appropriate as dictated by individual site conditions) of the construction. The use of a combination of sediment and erosion control measures in order to achieve maximum pollutant removal will be utilized. Sediment traps will be checked regularly for sediment cleanout. Sediment shall be removed and the basin restored to its original dimensions when the sediment has accumulated to one half the design volume of the wet storage. Sediment shall be disposed in suitable areas and in such a manner that will not erode or cause sedimentation problems.

### **ESTABLISH STABILIZED CONSTRUCTION EXITS**

Construction entrance locations for vehicle tracking control (VTC) will be established from entry points off of Peterson Rd and Canada Dr. The construction entrances will be at least 50 feet in length and approximately 12 feet wide and graded so runoff does not leave the project site. The aggregate will be established at 8 inches thick on top of 4 inch minimum thick free draining material on top of geotextile and will consist of Type G dense graded material. A stabilized stone pad with a filter fabric under liner will be placed at points of vehicular ingress and egress.

### **ADDITIONAL BMP'S BMP SCHEDULE:**

All Sediment and Erosion control Best Management Practices (BMP's - detailed below and only on BMP site map and details if utilized onsite) will be installed prior to any excavation or demolition and will be coordinated with the construction schedule. As construction changes and new temporary BMP's are needed to control sediment and erosion, temporary BMP's will be installed within 24 hours of inspection report.

**RECOMMENDED BMP'S:** ALL RECOMMENDED BMP'S WILL BE INSTALLED PRIOR TO EXCAVATION NEAR ANY SENSITIVE AREAS.

**Culvert Inlet Protection** will be used to protect existing and new culvert inlets. Inlet Protection Detail will be included in Appendix before using onsite. Removal of this BMP will occur only after vegetation is established to a minimum of 70% pre-construction coverage and after removal of BMP all sediment builds up will be removed and the area exposed shall be seeded.

**Silt Fence** is to be installed in sensitive areas to protect stream channels, pond, and overland runoff. On this site it will be used to protect runoff from the slip pits. See Silt Fence Detail. Removal of this BMP will occur only after vegetation is established to a minimum of 70% pre-construction coverage and after removal of BMP all sediment builds up will be removed and the area exposed shall be seeded.

**Vehicle Tracking Control** is needed at the main construction entrance location. Vehicle tracking control shall be installed at the edge of the construction staging area where construction vehicles regularly exit onto existing asphalt road. If sediment tracking occurs it will be cleaned within 24 hours.

See Vehicle Tracking Control Detail in Construction Drawings. Removal of this BMP will occur only after project is substantially complete and is ready for seeding operations; the area will then be seeded per specification with the rest of the project.

**Check Dams** (rip rap) will be used to reduce storm water velocities in drainage channels during construction as a temporary measure until permanent stabilization can be created and vegetation has been established. Check Dam Detail will be included in the Appendix before using onsite. Removal of this BMP will occur only after vegetation is established to a minimum of 70% pre-construction coverage and after removal of BMP all sediment build-up will be removed and the area exposed shall be seeded.

**Portable Toilets:** Portable toilets are brought in from a service contractor and will be maintained in accordance with standard waste disposal practices using vacuum trucks

and place on stable ground to minimize risk of spillage. All portable toilets will be kept a minimum of 500' from any waterway.

**Waste Disposal:** If needed Roll offs will be utilized for standard construction waste. A qualified contractor will remove waste weekly and take to an appropriate dump site off this project.

**PERMANENT BMP'S:**

**Re-vegetation:** During construction any disturbed area not being currently worked left dormant longer than 14 days will be re-vegetated per specification with native seed and mulched and crimped with weed free straw.

All BMPs shall be installed and maintained in accordance with the most recent Mile High Flood District Urban Storm Drainage Criteria Manual.

## VIII. MATERIALS HANDLING AND SPILL PREVENTION

### MATERIAL HANDLING AND WASTE MANAGEMENT

The site will use a private refuse collector that will remove litter twice weekly. No less than one litter receptacle will be present at the construction site. In the event that unusual items such as tanks, cylinders, unidentified containers, etc. which could contain potentially hazardous materials are discovered or disturbed, the Fire and Rescue services will be notified. Litter and debris will be picked up and disposed of properly daily. Temporary toilet facilities will be located 500 feet away from any storm drain inlets and all waters of the state.

### ESTABLISH PROPER BUILDING MATERIAL STAGING AREAS

A designated staging area will be used, location to be determined based on available space in the field and plans will be redline. The staging area will be contained per SWMP guidelines. All Equipment and Materials will be brought into the site as needed.

### DESIGNATE WASHOUT AREAS

A concrete washout will be installed to detail as shown on the Construction Drawings and will be placed more than 500 feet away from any waters of the state.

### ESTABLISH PROPER EQUIPMENT/VEHICLE FUELING AND MAINTENANCE PRACTICES

During construction the site will be exposed to operation and maintenance of construction equipment. The contractor shall be responsible for all activities such as fueling, oil changing, lubrication and repair which require use of petroleum products. Such products shall be transported to and from the site in special trucks equipped for that purpose. No waste petroleum products, rags, residue, or equipment parts shall be left on site. In the event of a spill or leak, causing soil to be contaminated, that soil shall be excavated placed in sealed barrels and removed from the site for transport to an approved location for disposal.

### **CONTROL EQUIPMENT/VEHICLE WASHING**

This activity will not be allowed onsite.

### **ANY ADDITIONAL BMPs**

Additional BMP's will be added to this SWMP as needed.

### **ALLOWABLE NON-STORMWATER DISCHARGE MANAGEMENT**

There are no visible natural springs or irrigation, or other non-stormwater discharges anticipated to be encountered.

### **SELECTING POST-CONSTRUCTION BMPs**

Post Construction BMPs. Re-vegetation including seeding, mulching and erosion control blanket will be final BMP's. Permanent stabilization will be achieved with 70% preconstruction vegetative establishment.

### **SPILL PREVENTION AND CONTROL PLAN**

The SITE SUPERINTENDENT will act as the point of contact for any spill that occurs at this jobsite. The project manager will be responsible for implementation of prevention practices, spill containment / cleanup, worker training, reporting and complete documentation in the event of a spill. The ECO shall immediately notify the Owner, /Construction Manager, STATE and the Local Fire Department in addition to the legally required Federal, State, and Local reporting channels (including the National Response Center, 800.424.8802) if a reportable quantity is released to the environment.

**SPILL PREVENTION BEST MANAGEMENT PRACTICES** This section describes spill prevention methods Best Management Practices (BMP) that will be practiced to eliminate spills before they happen.

- **Equipment Staging and Maintenance:** Store and maintain equipment in a designated area Reduce the amount of hazardous materials and waste by substituting non-hazardous or less hazardous materials. Use secondary containment (drain pan) to catch spills when removing or changing fluids. Use proper equipment (pumps, funnels) to transfer fluids Keep spill kits readily accessible Check incoming vehicles for leaking oil and fluids. Transfer used fluids and oil filters to waste or recycling drums immediately following generation. Inspect equipment routinely for leaks and spills Repair equipment immediately, if necessary, implement a preventative maintenance schedule for equipment and vehicles.
- **Fueling Area:** Perform fueling in designated fueling area minimum 50' away from federal waters Use secondary containment (drain pan) to catch spills Use proper equipment (pumps, funnels) to transfer fluids Keep spill kits readily accessible Inspect fueling areas routinely for leaks and spills Hazardous Material Storage Areas Reduce the amount of hazardous materials by substituting non-hazardous or Less hazardous materials.

- Hazardous Material Storage Areas: Minimize the quantity of hazardous materials brought onsite. Store hazardous materials in a designated area away from drainage points.
- Unexpected Contaminated Soil and Water: Perform all excavation activities carefully and only after the Owner/Construction Manager directed any activities.

### SPILL CONTAINMENT METHODS

The following discussion identifies the types of secondary containment that will be used in the event of a spill. The Table below summarizes the containment methods for each potential source.

- Equipment Staging and Maintenance Area: An equipment leak from a fuel tank, equipment seal, or hydraulic line will be contained within a spill containment cell placed beneath all stationary potential leak sources. An undetected leak from parked equipment will be cleaned up using hand shovels and containerized in a 55-gallon steel drum for offsite disposal.
- Fueling Area: A small spill during fueling operations will be contained using fuel absorbent pads at the nozzle. The transfer of fuel into portable equipment will be performed using a funnel and/or hand pump and a spill pad used to absorb any incidental spills/drips. Any leaking tanks or drums will have fluids removed and transferred to another tank, drum, or container for the fluids. A spill response kit will be located near the fueling area or on the fuel truck for easy access. The spill response kit will include plastic sheeting, tarps, over pack drums, absorbent litter, and shovels.
- Hazardous Material Storage Area: A spill from containers or cans in a hazardous material storage area will be contained within the storage cabinet these materials are kept in.
- Unexpected Contaminated Soil: If contaminated soil is encountered during the project, the Owner/Construction Manager will be notified immediately. Small quantities of suspected contaminated soil will be placed on a 6-mil plastic liner and covered with 6-mil plastic. A soil berm or silt fence will be used to contain the stockpile and prevent migration of contaminated liquids in the soil.

**Spill Prevention and Containment Methods Table**

Potential Spill Source	Response Method
Equipment Staging and Maintenance Area	Spill containment pad, spill kit, pumps, funnels
Fueling Area (site equipment only)	Spill containment pad, spill kit, pumps, funnels
Hazardous Material Staging Area	Spill containment pad, spill kit, pumps, funnels
Unexpected Contaminated Soil	Plastic liner, plastic cover, soil berm, hay bales, lined super sacks



## **SPILL COUNTERMEASURES**

Every preventative measure shall be taken to keep contaminated or hazardous materials contained. If a release occurs, the following actions shall be taken:

1. Stop the Spill: The severity of a spill at the site is anticipated to be minimal as large containers/quantities of Hazardous Materials (HM) are not anticipated. The type of spill would occur while dispensing material at the HM storage facility and would likely be contained in secondary containment. Thus, the use spill kits or other available absorbent materials should stop the spill.
2. Warn Others: Notify co-workers and supervisory personnel of the release. Notify emergency responders if appropriate. For site personnel, an alarm system will consist of three one second blasts on an air horn sounded by the person discovering a spill or fire. In the event of any spill, the Superintendent and Project Manager shall be notified if the spill is 5 gallons or more the STATE will be contacted along with the Fire Department.
3. Isolate the Area: Prevent public access to the area and continue to minimize the spread of the material. Minimize personal exposure throughout emergency response actions.
4. Containment: A spill shall only be contained by trained personnel and if it is safe to do so. **DO NOT PLACE YOURSELF IN DANGER.** Attempt to extinguish a fire only if it is in the incipient stage; trash can size or smaller. For larger spills, wait for the arrival of emergency response personnel and provide directions to the location of the emergency.
5. Complete a Spill and Incident Report: For each spill of a Hazardous Material a spill and incident report shall be completed and submitted to the Owner/Construction Manager and if applicable to the Engineer and the State of Colorado Department of Public Health and Environment

## **X. RECEIVING WATERS**

The project site is located within the Sand Creek Basin. Stormwater from this site drains to one of two existing curb flowlines at the southeastern (Canada Dr) and southwestern (Peterson Rd) project boundary. No sub-regional or regional detention facilities exist in close proximity to the project site.

Stream Crossing – There are no stream crossings required for this development.

## **IX. INSPECTION AND RECORD KEEPING**

The project is subject to inspections by the Colorado Division of Public Health and Environment (CDPHE), the Environmental Protection Agency (EPA), and El Paso County at any time.

Inspection of the stormwater management system shall be performed, by the SWMP Administrator, at least every 14 calendar days and after the occurrence of precipitation or snow melt event that may cause noticeable erosion or run-off. Time span greater than 14 calendar days is a violation of the CDPS permit.

### **SWMP ADMINISTRATOR**

The individual(s), position, or title responsible for developing, implementing, maintaining, and revising the SWMP is to be determined upon award of the project. The individual(s) will be sufficiently qualified for the required duties per the *El Paso County ECM Appendix I.5*. The individual listed as the Erosion Control Supervisor shall fill out the information below and place in the on-site copy before beginning installation of the BMPs for this site and notify the County of the appropriate contact information.

SWMP Administrator Name:

Cell Phone:

Office Phone:

Email:

### **INSPECTION SCHEDULES**

Inspections of the stormwater management system are required at least every 14 calendar days and within 24 hours after any precipitation or snowmelt event that causes surface runoff. A more frequent inspection schedule may be necessary to ensure that BMPs continue to operate as designed.

Differences or modifications in the field from the approved SWMP are required to be made within 72 hours site changes are observed. The SWMP shall be onsite at all times when onsite construction activity is occurring.

### **INSPECTION SCOPE**

The construction site perimeter, all disturbed areas, material and/or waste storage areas that are exposed to precipitation, discharge locations, and locations where vehicles access the site shall be inspected for evidence of, or the potential for pollutants leaving the construction site boundaries or discharging to State Waters. All erosion and sediment control practices identified in the SWMP shall be evaluated to ensure that they are maintained and operating correctly.

### **INSPECTION REPORT**

A thorough record of inspection shall be maintained and identify any incidents of non-compliance with the SWMP. Inspection records shall be retained for three years from expiration or inactivation of permit coverage. Federal, State, local authority reserves the right to request that a copy of the inspection reports be submitted. At a minimum, the inspection report shall include the following:

1. Inspection date
2. Name(s) and title(s) and signature(s) of personnel making the inspection
3. Location(s) of discharges of sediment or other pollutants from the site
4. Location(s) of BMPs that need to be maintained
5. Location(s) of BMPs that failed to operate as designed or proved inadequate for a particular location
6. Location(s) where additional BMPs are needed or were not in place at the time of inspection
7. Deviations from the minimum inspection schedule
8. Description of corrective action for items c, d, e and f above, dates corrective action(s) taken, and measures taken to prevent future violations, including requisite changes to the SWMP, as necessary
9. After adequate corrective action(s) have been taken, or where a report does not identify any incidents requiring corrective action, the report shall contain a signed statement indicating the site is in compliance with the permit to the best of the signer's knowledge and belief
10. The date and amount of storm or snowmelt events that cause erosion.

### **BMP MAINTENANCE/REPLACEMENT AND FAILED BMPs**

Adequate site assessment shall be performed as part of comprehensive Inspection and Maintenance procedures to assess the adequacy of BMPs at the site and to evaluate the necessity of changes to those BMPs to ensure continued effective performance. Where site assessment results in the determination that new or replacement BMPs are necessary, the BMPs shall be installed to ensure ongoing implementation. Failed BMPs must be addressed as soon as possible, in most cases immediately, to ensure continued performance and minimize the likelihood of pollutant discharge. The SWMP shall be updated once new BMPs are installed or failed BMPs replaced. A specific timeline for implementing maintenance procedures is not included in the State Permit because BMP maintenance is expected to be proactive, not responsive. Observations resulting in BMP maintenance activities can be made during a site inspection, or during general observations of site conditions. BMPs shall be maintained per DCM2 criteria and ECM criteria. Please refer to the Appendix for specific maintenance required for each BMP.

### **PLAN REVIEW AND REVISIONS**

1. The plan must be signed in accordance with the general permit.
2. The plan must be made available, upon request, to CDPHE, United States Environmental Protection Agency, or operator of the local municipal storm sewer system, if applicable.
3. The plan must be amended whenever there is a change in design, construction, operation or maintenance that could have a significant effect on the potential for the discharge of pollutants to State Waters. It also must be amended if it is found to be ineffective in controlling pollutants present in stormwater.

### **RECORD KEEPING AND DOCUMENTING OF INSPECTION**

The permittee shall retain a copy of the SWMP required by this permit (including a copy of the permit language) at the construction site (or other local location accessible to the Director; a State or local agency approving sediment and erosion plans, grading plans, or stormwater management plans; local government officials; or the operator of a municipal separate storm sewer receiving discharges from the site) from the date of project initiation to the date of final stabilization. Permittees with day-to-day operational control over SWMP implementation shall have a copy of the SWMP available at a central location on-site for the use of all operators and those identified as having responsibilities under the SWMP whenever they are on the construction site. If minor modifications to the SWMP are required, they shall be recorded on the owner's copy of the SWMP and be available during inspections. Whenever a significant change is made to the SWMP (including changes to design, construction, operation or maintenance), an amended SWMP shall be submitted for review and approval. The following documents must be kept in a field office, trailer, shed or vehicle that is onsite during normal working hours:

1. A completed and signed copy of the Notice of Intent
2. The permit coverage letter from the Colorado Department of Public Health and Environment (CDPHE)

3. The Stormwater Management Plan
4. Site Inspection Records
5. A copy of the Colorado General Permit for Stormwater Discharges from Construction Activities

If a reasonable onsite location is not available, then the documents may be retained at a readily available alternative location, preferably with the SWMP plan contact. If the site is inactive, then the documents may be stored at a local office.

All records and information must be kept for at least three years or longer if requested by the Colorado Department of Public Health and Environment or United States Environmental Protection Agency.

### **RECORD KEEPING**

The SWMP is a "living document" that is continuously reviewed and modified. The ECS shall make changes to the SWMP, including but not limited to: additions, deletions, changing locations of BMP's shall be marked in the plans, dated and initialed at time of occurrence.

All inspection and maintenance activities or other repairs will be documented by the ECS and the records kept on the project site.

Records of spill, leaks or overflows that result in the discharge of pollutants will be documented and maintained. The following Information will be recorded for all occurrences:

1. Time and date
2. Weather conditions
3. Reasons for spill
4. A release of any chemical, oil, petroleum product, sewage, etc., which may enter state waters must be reported.

At 14-day inspections incidents of noncompliance, such as uncontrolled releases of pollutants including mud, muddy water or measurable quantities of sediment found off-site shall be noted, along with a brief explanation as to measures taken to prevent future violations and measures taken to clean up sediment that has left the site.

After measures have been taken to correct any problems and recorded, or where a report does not identify incidents of noncompliance, the report shall contain a signed certification indicating the site is in compliance.

**Signature Page:**

**Engineer's Statement:**

The Erosion and Stormwater Quality Control/Grading Plan was prepared under my direction and supervision and is correct to the best of my knowledge and belief. If such work is performed in accordance with the grading and erosion control plan, the work will not become a hazard to life and limb, endanger property, or adversely affect the safety, use, or stability of public way, drainage channel, or other property.



07/21/2023

\_\_\_\_\_  
Brady A. Shyrock  
Registered Professional Engineer  
State of Colorado No. 38164

\_\_\_\_\_  
Date



**Developer's Statement:**

The owner will comply with the requirements of the Erosion and Stormwater Quality Control Plan including temporary BMP inspection requirements and final stabilization requirements. I acknowledge the responsibility to determine whether the construction activities on these plans require Colorado Discharge Permit System (CDPS) permitting for Stormwater discharges associated with Construction Activity.

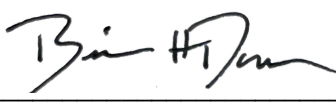
Developer/ Owner Signature: \_\_\_\_\_  

Name of Developer/ Owner: Brian Duncan

DBA: Johnson Development Associates, Inc. Phone: 704-909-9186

Title: Development Manager Email: bduncan@johnsondevelopment.net

Address: 101 N Pacific Coast Hwy, Ste. 308, El Segundo, CA 90245 Fax: 704-909-9186

Developer/ Owner Signature: \_\_\_\_\_

Name of Developer/ Owner: \_\_\_\_\_

DBA: \_\_\_\_\_ Phone: \_\_\_\_\_

Title: \_\_\_\_\_ Email: \_\_\_\_\_

Address: \_\_\_\_\_ Fax: \_\_\_\_\_

## APPENDIX A



6855 CONSTITUTION AVE. STORAGE SITE

6855 CONSTITUTION AVE.  
COLORADO SPRINGS, CO

VICINITY / LOCATION MAP

Project No: JDA02.20

Drawn By: BAS

Checked By: RGD

Date: 04/22/2022



6162 S. Willow Drive, Suite 320  
Greenwood Village, CO 80111  
303.770.8884 • [GallowayUS.com](http://GallowayUS.com)



## APPENDIX B

Soil Map—El Paso County Area, Colorado

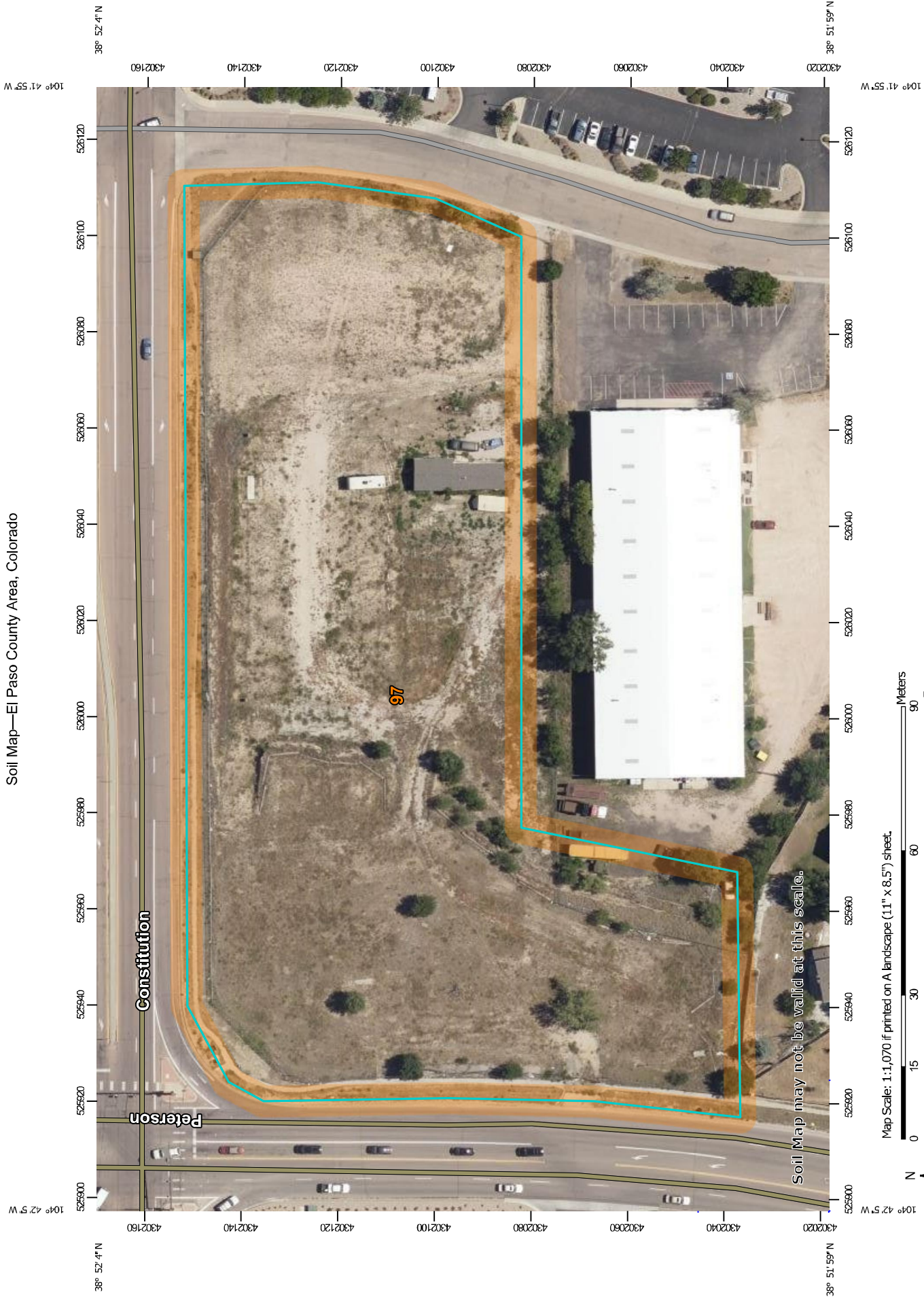



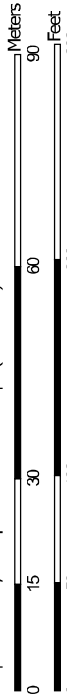

































Map Scale: 1:1,070 if printed on A landscape (11" x 8.5") sheet.



Map projection: Web Mercator Corner coordinates: WGS84 Edge tics: UTM Zone 13N WGS84

## MAP LEGEND

-  Area of Interest (AOI)
- Soils**
-  Soil Map Unit Polygons
-  Soil Map Unit Lines
-  Soil Map Unit Points
- Special Point Features**
-  Blowout
-  Borrow Pit
-  Clay Spot
-  Closed Depression
-  Gravel Pit
-  Gravelly Spot
-  Landfill
-  Lava Flow
-  Marsh or swamp
-  Mine or Quarry
-  Miscellaneous Water
-  Perennial Water
-  Rock Outcrop
-  Saline Spot
-  Sandy Spot
-  Severely Eroded Spot
-  Sinkhole
-  Slide or Slip
-  Sodic Spot
-  Spoil Area
-  Stony Spot
-  Very Stony Spot
-  Wet Spot
-  Other
-  Special Line Features
- Water Features**
-  Streams and Canals
- Transportation**
-  Rails
-  Interstate Highways
-  US Routes
-  Major Roads
-  Local Roads
- Background**
-  Aerial Photography

## MAP INFORMATION

The soil surveys that comprise your AOI were mapped at 1:24,000.

Warning: Soil Map may not be valid at this scale.

Enlargement of maps beyond the scale of mapping can cause misunderstanding of the detail of mapping and accuracy of soil line placement. The maps do not show the small areas of contrasting soils that could have been shown at a more detailed scale.

Please rely on the bar scale on each map sheet for map measurements.

Source of Map: Natural Resources Conservation Service  
 Web Soil Survey URL:  
 Coordinate System: Web Mercator (EPSG:3857)

Maps from the Web Soil Survey are based on the Web Mercator projection, which preserves direction and shape but distorts distance and area. A projection that preserves area, such as the Albers equal-area conic projection, should be used if more accurate calculations of distance or area are required.

This product is generated from the USDA-NRCS certified data as of the version date(s) listed below.

Soil Survey Area: El Paso County Area, Colorado  
 Survey Area Data: Version 19, Aug 31, 2021

Soil map units are labeled (as space allows) for map scales 1:50,000 or larger.

Date(s) aerial images were photographed: Aug 19, 2018—Sep 23, 2018

The orthophoto or other base map on which the soil lines were compiled and digitized probably differs from the background imagery displayed on these maps. As a result, some minor shifting of map unit boundaries may be evident.

## Map Unit Legend

Map Unit Symbol	Map Unit Name	Acres in AOI	Percent of AOI
97	Truckton sandy loam, 3 to 9 percent slopes	3.8	100.0%
<b>Totals for Area of Interest</b>		<b>3.8</b>	<b>100.0%</b>

## El Paso County Area, Colorado

### 97—Truckton sandy loam, 3 to 9 percent slopes

#### Map Unit Setting

*National map unit symbol:* 2x0j2

*Elevation:* 5,300 to 6,850 feet

*Mean annual precipitation:* 14 to 19 inches

*Mean annual air temperature:* 48 to 52 degrees F

*Frost-free period:* 85 to 155 days

*Farmland classification:* Not prime farmland

#### Map Unit Composition

*Truckton and similar soils:* 85 percent

*Minor components:* 15 percent

*Estimates are based on observations, descriptions, and transects of the mapunit.*

#### Description of Truckton

##### Setting

*Landform:* Interfluves, hillslopes

*Landform position (two-dimensional):* Backslope

*Landform position (three-dimensional):* Side slope

*Down-slope shape:* Linear

*Across-slope shape:* Linear

*Parent material:* Re-worked alluvium derived from arkose

##### Typical profile

*A - 0 to 4 inches:* sandy loam

*Bt1 - 4 to 12 inches:* sandy loam

*Bt2 - 12 to 19 inches:* sandy loam

*C - 19 to 80 inches:* sandy loam

##### Properties and qualities

*Slope:* 3 to 9 percent

*Depth to restrictive feature:* More than 80 inches

*Drainage class:* Well drained

*Runoff class:* Low

*Capacity of the most limiting layer to transmit water (Ksat):* High  
(2.00 to 6.00 in/hr)

*Depth to water table:* More than 80 inches

*Frequency of flooding:* None

*Frequency of ponding:* None

*Calcium carbonate, maximum content:* 1 percent

*Maximum salinity:* Nonsaline (0.1 to 1.9 mmhos/cm)

*Available water supply, 0 to 60 inches:* Moderate (about 6.6 inches)

##### Interpretive groups

*Land capability classification (irrigated):* 6e

*Land capability classification (nonirrigated):* 6e

*Hydrologic Soil Group:* A  
*Ecological site:* R049XB210CO - Sandy Foothill  
*Hydric soil rating:* No

### **Minor Components**

#### **Blakeland**

*Percent of map unit:* 8 percent  
*Landform:* Interfluves, hillslopes  
*Landform position (two-dimensional):* Summit, shoulder, backslope  
*Landform position (three-dimensional):* Side slope, crest  
*Down-slope shape:* Convex, linear  
*Across-slope shape:* Convex, linear  
*Ecological site:* R049XB210CO - Sandy Foothill  
*Hydric soil rating:* No

#### **Bresser**

*Percent of map unit:* 7 percent  
*Landform:* Interfluves, low hills  
*Landform position (two-dimensional):* Footslope, toeslope  
*Landform position (three-dimensional):* Base slope  
*Down-slope shape:* Concave, linear  
*Across-slope shape:* Concave, linear  
*Ecological site:* R049XB210CO - Sandy Foothill  
*Hydric soil rating:* No

## **Data Source Information**

Soil Survey Area: El Paso County Area, Colorado  
Survey Area Data: Version 19, Aug 31, 2021

## APPENDIX C

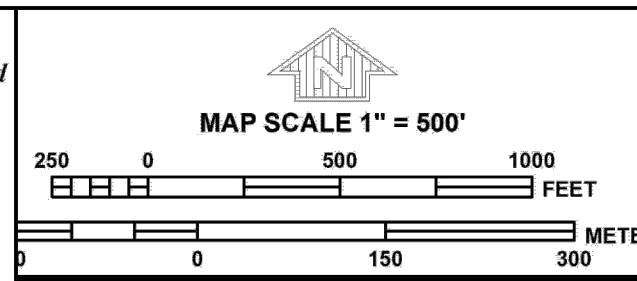
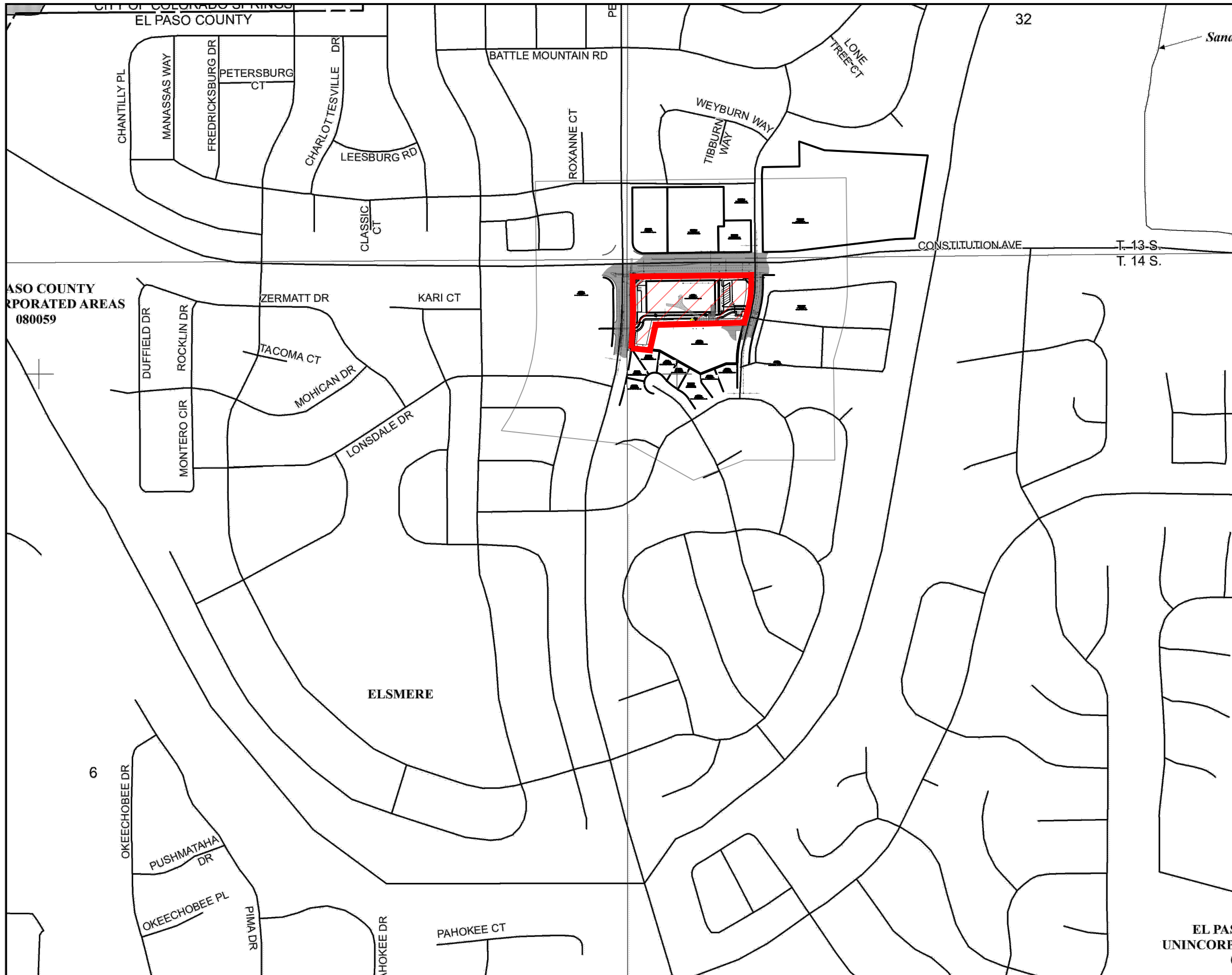

**NFP** PANEL 0752G

**FIRM**  
**FLOOD INSURANCE RATE MAP**  
**EL PASO COUNTY,**  
**COLORADO**  
**AND INCORPORATED AREAS**

**PANEL 752 OF 1300**  
 (SEE MAP INDEX FOR FIRM PANEL LAYOUT)

**CONTAINS:**

COMMUNITY	NUMBER	PANEL	SUFFIX
COLORADO SPRINGS, CITY OF	080060	0752	G
EL PASO COUNTY	080059	0752	G

Notice: This map was reissued on 05/15/2020 to make a correction. This version replaces any previous versions. See the Notice-to-User Letter that accompanied this correction for details.

Notice to User: The Map Number shown below should be used when placing map orders; the Community Number shown above should be used on insurance applications for the subject community.

**MAP NUMBER**  
**08041C0752G**

**MAP REVISED**  
**DECEMBER 7, 2018**

Federal Emergency Management Agency

**EL PASO UNINCORPORATED AREAS 080059**

This is an official FIRMette showing a portion of the above-referenced flood map created from the MSC FIRMette Web tool. This map does not reflect changes or amendments which may have been made subsequent to the date on the title block. For additional information about how to make sure the map is current, please see the Flood Hazard Mapping Updates Overview Fact Sheet available on the FEMA Flood Map Service Center home page at <https://msc.fema.gov>.



## APPENDIX D



STANDARD NOTES FOR GEC PLANS

- 1. STORMWATER DISCHARGES FROM CONSTRUCTION SITES SHALL NOT CAUSE OR THREATEN TO CAUSE POLLUTION, CONTAMINATION, OR DEGRADATION OF STATE WATERS. ALL WORK AND EARTH DISTURBANCE SHALL BE DONE IN A MANNER THAT MINIMIZES POLLUTION OF ANY ON-SITE OR OFFSITE WATERS, INCLUDING METANES.
- 2. NOTWITHSTANDING ANYTHING DEPICTED IN THESE PLANS IN WORDS OR GRAPHIC REPRESENTATION, ALL DESIGN AND CONSTRUCTION RELATED TO ROADS, STORM DRAINAGE AND EROSION CONTROL SHALL CONFORM TO THE STANDARDS AND REQUIREMENTS OF THE MOST RECENT VERSION OF THE RELEVANT ADOPTED EL PASO COUNTY STANDARDS, INCLUDING THE LAND DEVELOPMENT CODE, THE ENGINEERING CRITERIA MANUAL, THE DRAINAGE CRITERIA MANUAL, AND THE DRAINAGE CRITERIA MANUAL VOLUME 2. ANY DEVIATIONS TO REGULATIONS AND STANDARDS MUST BE REQUESTED, AND APPROVED, IN WRITING.
- 3. A SEPARATE STORMWATER MANAGEMENT PLAN (SWMP) FOR THIS PROJECT SHALL BE COMPLETED AND AN EROSION AND STORMWATER QUALITY CONTROL PERMIT (ESQCP) ISSUED PRIOR TO COMMENCING CONSTRUCTION. DURING CONSTRUCTION THE SWMP IS THE RESPONSIBILITY OF THE DESIGNATED QUALIFIED STORMWATER MANAGER OR CERTIFIED EROSION CONTROL INSPECTOR AND SHALL BE LOCATED ON SITE AT ALL TIMES DURING CONSTRUCTION AND SHALL BE KEPT UP TO DATE WITH WORK PROGRESS AND CHANGES IN THE FIELD.
- 4. ONCE THE ESQCP IS APPROVED AND A NOTICE TO PROCEED HAS BEEN ISSUED, THE CONTRACTOR MAY INSTALL THE INITIAL STAGE EROSION AND SEDIMENT CONTROL MEASURES AS INDICATED ON THE APPROVED GEC. A PRECONSTRUCTION MEETING BETWEEN THE CONTRACTOR, ENGINEER, AND EL PASO COUNTY WILL BE HELD PRIOR TO ANY CONSTRUCTION. IT IS THE RESPONSIBILITY OF THE APPLICANT TO COORDINATE THE MEETING TIME AND PLACE WITH COUNTY STAFF.
- 5. CONTROL MEASURES MUST BE INSTALLED PRIOR TO COMMENCEMENT OF ACTIVITIES THAT MAY CONTRIBUTE POLLUTANTS TO STORMWATER. TEMPORARY SEDIMENT AND EROSION CONTROL MEASURES FOR ALL SLOPES, CHANNELS, DITCHES, OR ANY DISTURBED LAND AREA SHALL BE COMPLETED IMMEDIATELY UPON COMPLETION OF THE DISTURBANCE.
- 6. ALL TEMPORARY SEDIMENT AND EROSION CONTROL MEASURES SHALL BE MAINTAINED AND REMAIN IN EFFECTIVE OPERATING CONDITION UNTIL PERMANENT SOIL EROSION CONTROL MEASURES ARE IMPLEMENTED AND FINAL STABILIZATION IS ESTABLISHED. ALL PERSONS ENGAGED IN LAND DISTURBANCE ACTIVITIES SHALL ASSESS THE ADEQUACY OF CONTROL MEASURES AT THE SITE AND IDENTIFY IF CHANGES TO THOSE CONTROL MEASURES IS NEEDED TO ENSURE THE CONTINUED EFFECTIVE PERFORMANCE OF THE CONTROL MEASURES. ALL CHANGES TO TEMPORARY SEDIMENT AND EROSION CONTROL MEASURES MUST BE INCORPORATED INTO THE STORMWATER MANAGEMENT PLAN PRIOR TO IMPLEMENTATION.
- 7. TEMPORARY STABILIZATION SHALL BE IMPLEMENTED ON DISTURBED AREAS AND STOCKPILES WHERE GROUND DISTURBING CONSTRUCTION ACTIVITY HAS PERMANENTLY CEASED OR TEMPORARILY CEASED FOR LONGER THAN 14 DAYS. AN AREA THAT IS GOING TO REMAIN IN AN INTERM STATE FOR MORE THAN 60 DAYS SHALL ALSO BE STABILIZED.
- 8. FINAL STABILIZATION MUST BE IMPLEMENTED AT ALL APPLICABLE CONSTRUCTION SITES. FINAL STABILIZATION IS ACHIEVED WHEN ALL GROUND DISTURBING ACTIVITIES ARE COMPLETE AND ALL DISTURBED AREAS EITHER HAVE A UNIFORM VEGETATIVE COVER WITH INDIVIDUAL PLANT DENSITY OF 70 PERCENT OF PRE-DISTURBANCE LEVELS ESTABLISHED OR EQUIVALENT PERMANENT ALTERNATIVE STABILIZATION METHOD IS IMPLEMENTED. ALL TEMPORARY SEDIMENT AND EROSION CONTROL MEASURES SHALL BE REMOVED UPON FINAL STABILIZATION AND BEFORE PERMIT CLOSURE.
- 9. ALL PERMANENT STORMWATER MANAGEMENT FACILITIES SHALL BE INSTALLED AS DEFINED IN THE APPROVED PLANS. ANY PROPOSED CHANGES THAT EFFECT THE HYDROLOGY OR HYDRAULICS OF A PERMANENT STORMWATER MANAGEMENT STRUCTURES MUST BE APPROVED BY THE ECM ADMINISTRATOR PRIOR TO IMPLEMENTATION.
- 10. EARTH DISTURBANCES SHALL BE CONDUCTED IN SUCH A MANNER SO AS TO EFFECTIVELY MINIMIZE ACCELERATED SOIL EROSION AND RESULTING SEDIMENTATION. ALL DISTURBANCES SHALL BE DESIGNED, CONSTRUCTED, AND COMPLETED SO THAT THE EXPOSED AREA OF ANY DISTURBED LAND SHALL BE LIMITED TO THE SHORTEST PRACTICAL PERIOD OF TIME. PRE-EXISTING VEGETATION SHALL BE PROTECTED AND MAINTAINED WITHIN 50 HORIZONTAL FEET OF A WATERS OF THE STATE UNLESS SHOWN TO BE INFEASIBLE AND SPECIFICALLY REQUESTED AND APPROVED.
- 11. COMPACTION OF SOIL MUST BE PREVENTED IN AREAS DESIGNATED FOR INFILTRATION CONTROL MEASURES OR WHERE FINAL STABILIZATION WILL BE ACHIEVED BY VEGETATIVE COVER. AREAS DESIGNATED FOR INFILTRATION CONTROL SHALL ALSO BE PROTECTED FROM SEDIMENTATION DURING CONSTRUCTION UNTIL FINAL STABILIZATION IS ACHIEVED.
- 12. ANY TEMPORARY OR PERMANENT FACILITY DESIGNED AND CONSTRUCTED FOR THE CONVEYANCE OF STORMWATER ARISING, THROUGH, OR FROM THE EARTH DISTURBANCE AREA SHALL BE A STABILIZED CONVEYANCE DESIGNED TO MINIMIZE EROSION AND THE DISCHARGE OF SEDIMENT OFF SITE.
- 13. CONCRETE WASH WATER SHALL BE CONTAINED AND DISPOSED OF IN ACCORDANCE WITH THE SWMP. NO WASH WATER SHALL BE DISCHARGED TO OR ALLOWED TO RUNOFF TO STATE WATERS, INCLUDING ANY SURFACE OR SUBSURFACE STORM DRAINAGE SYSTEM OR FACILITIES. CONCRETE WASHOUT SHALL NOT BE LOCATED IN AN AREA WHERE SHALLOW GROUNDWATER MAY BE PRESENT, OR WITHIN 50 FEET OF A SURFACE WATER BODY.
- 14. DURING DEWATERING OPERATIONS OF UNCONTAMINATED GROUND WATER MAY BE DISCHARGED ON SITE, BUT SHALL NOT LEAVE THE SITE IN THE FORM OF SURFACE RUNOFF UNLESS AN APPROVED STATE DEWATERING PERMIT IS IN PLACE.
- 15. EROSION CONTROL, BLANKETING OR OTHER PROTECTIVE COVERING SHALL BE USED ON SLOPES STEEPER THAN 3:1.
- 16. CONTRACTOR SHALL BE RESPONSIBLE FOR THE REMOVAL OF ALL WASTES FROM THE CONSTRUCTION SITE FOR DISPOSAL IN ACCORDANCE WITH LOCAL AND STATE REGULATORY REQUIREMENTS. NO CONSTRUCTION DEBRIS, TREE SLASH, BUILDING MATERIAL WASTES OR UNUSED BUILDING MATERIALS SHALL BE BURIED, DUMPED, OR DISCHARGED AT THE SITE.
- 17. WASTE MATERIALS SHALL NOT BE TEMPORARILY PLACED OR STORED IN THE STREET, ALLEY, OR OTHER PUBLIC WAY, UNLESS IN ACCORDANCE WITH AN APPROVED TRAFFIC CONTROL PLAN. CONTROL MEASURES MAY BE REQUIRED BY EL PASO COUNTY ENGINEERING IF DEEMED NECESSARY, BASED ON SPECIFIC CONDITIONS AND CIRCUMSTANCES.
- 18. TRACKING OF SOILS AND CONSTRUCTION DEBRIS OFF-SITE SHALL BE MINIMIZED. MATERIALS TRACKED OFF-SITE SHALL BE CLEANED UP AND PROPERLY DISPOSED OF IMMEDIATELY.
- 19. THE OWNER/DEVELOPER SHALL BE RESPONSIBLE FOR THE REMOVAL OF ALL CONSTRUCTION DEBRIS, DIRT, TRASH, ROCK, SEDIMENT, AND SAND THAT MAY ACCUMULATE IN ROADS, STORM DRAINS AND OTHER DRAINAGE CONVEYANCE SYSTEM AND STORMWATER APPURTENANCES AS A RESULT OF SITE DEVELOPMENT.
- 20. THE QUANTITY OF MATERIALS STORED ON THE PROJECT SITE SHALL BE LIMITED, AS MUCH AS PRACTICAL, TO THAT QUANTITY REQUIRED TO PERFORM THE WORK IN AN ORDERLY SEQUENCE. ALL MATERIALS STORED ON-SITE SHALL BE STORED IN A NEAT, ORDERLY MANNER, IN THEIR ORIGINAL CONTAINERS, WITH ORIGINAL MANUFACTURER'S LABELS.
- 21. NO CHEMICALS ARE TO BE USED BY THE CONTRACTOR, WHICH HAVE THE POTENTIAL TO BE RELEASED IN STORMWATER UNLESS PERMISSION FOR THE USE OF A SPECIFIC CHEMICAL IS GRANTED IN WRITING BY THE ECM ADMINISTRATOR. IN GRANTING THE USE OF SUCH CHEMICALS, SPECIAL CONDITIONS AND MONITORING MAY BE REQUIRED.
- 22. BULK STORAGE OF PETROLEUM PRODUCTS OR OTHER LIQUID CHEMICALS IN EXCESS OF 55 GALLONS SHALL HAVE ADEQUATE SECONDARY CONTAINMENT PROTECTION TO CONTAIN ALL SPILLS AND PREVENT ANY SPILLED MATERIAL FROM ENTERING STATE WATERS, INCLUDING ANY SURFACE OR SUBSURFACE STORM DRAINAGE SYSTEM OR FACILITIES.
- 23. NO PERSON SHALL CAUSE THE IMPEDIMENT OF STORMWATER FLOW IN THE FLOW LINE OF THE CURB AND GUTTER OR DITCH EXCEPT WITH APPROVED SEDIMENT CONTROL MEASURES.
- 24. INDIVIDUALS SHALL COMPLY WITH THE COLORADO WATER QUALITY CONTROL ACT (TITLE 25, ARTICLE 8, OPS), AND THE CLEAN WATER ACT (33 USC 1344), IN ADDITION TO THE REQUIREMENTS INCLUDED IN THE ECM VOLUME II AND THE ECM APPENDIX I. ALL APPROPRIATE PERMITS MUST BE OBTAINED BY THE CONTRACTOR PRIOR TO CONSTRUCTION (NPDES, FLOODPLAIN, 404, FUGITIVE DUST, ETC.). IN THE EVENT OF CONFLICTS BETWEEN THESE REQUIREMENTS AND LAWS, RULES, OR REGULATIONS OF OTHER FEDERAL, STATE, OR COUNTY AGENCIES, THE MORE RESTRICTIVE LAWS, RULES, OR REGULATIONS SHALL APPLY.
- 25. ALL CONSTRUCTION TRAFFIC MUST ENTER/EXIT THE SITE AT APPROVED CONSTRUCTION ACCESS POINTS.
- 26. PRIOR TO ACTUAL CONSTRUCTION THE PERMITEE SHALL VERIFY THE LOCATION OF EXISTING UTILITIES.
- 27. A WATER SOURCE SHALL BE AVAILABLE ON SITE DURING EARTHWORK OPERATIONS AND UTILIZED AS REQUIRED TO MINIMIZE DUST FROM EARTHWORK EQUIPMENT AND WIND.
- 28. THE SOILS REPORT, TITLED "GEOTECHNICAL ENGINEERING STUDY SELF-STORAGE FACILITY 6855 CONSTITUTION AVENUE" FOR THIS SITE HAS BEEN PREPARED BY KUMAR & ASSOCIATES, INC., DATED FEBRUARY 3, 2022 AND SHALL BE CONSIDERED A PART OF THESE PLANS.
- 29. AT LEAST TEN (10) DAYS PRIOR TO THE ANTICIPATED START OF CONSTRUCTION, FOR PROJECTS THAT WILL DISTURB 1 ACRE OR MORE, THE OWNER OR OPERATOR OF CONSTRUCTION ACTIVITY SHALL SUBMIT A PERMIT APPLICATION FOR STORMWATER DISCHARGE TO THE COLORADO DEPARTMENT OF PUBLIC HEALTH AND ENVIRONMENT, WATER QUALITY DIVISION. THE APPLICATION CONTAINS CERTIFICATION OF COMPLETION OF A STORMWATER MANAGEMENT PLAN (SWMP), OF WHICH THIS GRADING AND EROSION CONTROL PLAN MAY BE A PART. FOR INFORMATION OR APPLICATION MATERIALS CONTACT: COLORADO DEPARTMENT OF PUBLIC HEALTH AND ENVIRONMENT WATER QUALITY CONTROL DIVISION WOOD - PERMITS 4300 CHERRY CREEK DRIVE SOUTH DENVER, CO 80246-1530 ATTN: PERMITS UNIT

STANDARD NOTES FOR CONSTRUCTION PLANS

- 1. ALL DRAINAGE AND ROADWAY CONSTRUCTION SHALL MEET THE STANDARDS AND SPECIFICATIONS OF THE CITY OF COLORADO SPRINGS/EL PASO COUNTY DRAINAGE CRITERIA MANUAL, VOLUMES 1 AND 2, AND THE EL PASO COUNTY ENGINEERING CRITERIA MANUAL.
- 2. CONTRACTOR SHALL BE RESPONSIBLE FOR THE NOTIFICATION AND FIELD NOTIFICATION OF ALL EXISTING UTILITIES, WHETHER SHOWN ON THE PLANS OR NOT, BEFORE BEGINNING CONSTRUCTION. LOCATION OF EXISTING UTILITIES SHALL BE VERIFIED BY THE CONTRACTOR PRIOR TO CONSTRUCTION. CALL 811 TO CONTACT THE UTILITY NOTIFICATION CENTER OF COLORADO (UNCC).
- 3. CONTRACTOR SHALL KEEP A COPY OF THESE APPROVED PLANS, THE GRADING AND EROSION CONTROL PLAN, THE STORMWATER MANAGEMENT PLAN (SWMP), THE SOILS AND GEOTECHNICAL REPORT, AND THE APPROPRIATE DESIGN AND CONSTRUCTION STANDARDS AND SPECIFICATIONS AT THE JOB SITE AT ALL TIMES, INCLUDING THE FOLLOWING: A. EL PASO COUNTY ENGINEERING CRITERIA MANUAL (ECM) B. CITY OF COLORADO SPRINGS/EL PASO COUNTY DRAINAGE CRITERIA MANUAL, VOLUMES 1 AND 2 C. COLORADO DEPARTMENT OF TRANSPORTATION (CDOT) STANDARD SPECIFICATIONS FOR ROAD AND BRIDGE CONSTRUCTION D. CDOT M & S STANDARDS
- 4. NOTWITHSTANDING ANYTHING DEPICTED IN THESE PLANS IN WORDS OR GRAPHIC REPRESENTATION, ALL DESIGN AND CONSTRUCTION RELATED TO ROADS, STORM DRAINAGE AND EROSION CONTROL SHALL CONFORM TO THE STANDARDS AND REQUIREMENTS OF THE MOST RECENT VERSION OF THE RELEVANT ADOPTED EL PASO COUNTY STANDARDS, INCLUDING THE LAND DEVELOPMENT CODE, THE ENGINEERING CRITERIA MANUAL, THE DRAINAGE CRITERIA MANUAL, AND THE DRAINAGE CRITERIA MANUAL VOLUME 2. ANY DEVIATIONS TO REGULATIONS AND STANDARDS MUST BE REQUESTED, AND APPROVED, IN WRITING. ANY MODIFICATIONS NECESSARY TO MEET CRITERIA AFTER-THE-FACT WILL BE ENTIRELY THE DEVELOPER'S RESPONSIBILITY TO RECTIFY.
- 5. IT IS THE DESIGN ENGINEER'S RESPONSIBILITY TO ACCURATELY SHOW EXISTING CONDITIONS, BOTH ONSITE AND OFFSITE, ON THE CONSTRUCTION PLANS. ANY MODIFICATIONS NECESSARY DUE TO CONFLICTS, OMISSIONS, OR CHANGED CONDITIONS WILL BE ENTIRELY THE DEVELOPER'S RESPONSIBILITY TO RECTIFY.
- 6. CONTRACTOR SHALL SCHEDULE A PRE-CONSTRUCTION MEETING WITH EL PASO COUNTY PLANNING AND COMMUNITY DEVELOPMENT (PCD) - INSPECTIONS, PRIOR TO STARTING CONSTRUCTION.
- 7. IT IS THE CONTRACTOR'S RESPONSIBILITY TO UNDERSTAND THE REQUIREMENTS OF ALL JURISDICTIONAL AGENCIES AND TO OBTAIN ALL REQUIRED PERMITS, INCLUDING BUT NOT LIMITED TO EL PASO COUNTY EROSION AND STORMWATER QUALITY CONTROL PERMIT (ESQCP), REGIONAL BUILDING FLOODPLAIN DEVELOPMENT PERMIT, U.S. ARMY CORPS OF ENGINEERS-ISSUED 401 AND/OR 404 PERMITS, AND COUNTY AND STATE FUGITIVE DUST PERMITS.
- 8. CONTRACTOR SHALL NOT DEViate FROM THE PLANS WITHOUT FIRST OBTAINING WRITTEN APPROVAL FROM THE DESIGN ENGINEER AND PCD. CONTRACTOR SHALL NOTIFY THE DESIGN ENGINEER IMMEDIATELY UPON DISCOVERY OF ANY ERRORS OR INCONSISTENCIES.
- 9. ALL STORM DRAIN PIPE SHALL BE CLASS II RCP UNLESS OTHERWISE NOTED AND APPROVED BY PCD.
- 10. CONTRACTOR SHALL COORDINATE GEOTECHNICAL TESTING PER ECM STANDARDS. PAVEMENT DESIGN SHALL BE APPROVED BY EL PASO COUNTY PCD PRIOR TO PLACEMENT OF CURB AND GUTTER AND PAVEMENT.
- 11. ALL CONSTRUCTION TRAFFIC MUST ENTER/EXIT THE SITE AT APPROVED CONSTRUCTION ACCESS POINTS.
- 12. SIGHT VISIBILITY TRIANGLES AS IDENTIFIED IN THE PLANS SHALL BE PROVIDED AT ALL INTERSECTIONS. OBSTRUCTIONS GREATER THAN 18 INCHES ABOVE FLOWLINE ARE NOT ALLOWED WITHIN SIGHT TRIANGLES.
- 13. SIGNING AND STRIPING SHALL COMPLY WITH EL PASO COUNTY DOT AND MUTCD CRITERIA. [IF APPLICABLE, ADDITIONAL SIGNING AND STRIPING NOTES WILL BE PROVIDED.]
- 14. CONTRACTOR SHALL OBTAIN ANY PERMITS REQUIRED BY EL PASO COUNTY DOT, INCLUDING WORK WITHIN THE RIGHT-OF-WAY AND SPECIAL TRANSPORT PERMITS.
- 15. THE LIMITS OF CONSTRUCTION SHALL REMAIN WITHIN THE PROPERTY LINE UNLESS OTHERWISE NOTED. THE OWNER/DEVELOPER SHALL OBTAIN WRITTEN PERMISSION AND EASEMENTS, WHERE REQUIRED, FOR ADJOINING PROPERTY OWNER(S) PRIOR TO ANY OFF-SITE DISTURBANCE, GRADING, OR CONSTRUCTION.

EROSION CONTROL NOTES

- 1. AT LEAST TEN DAYS PRIOR TO THE ANTICIPATED START OF CONSTRUCTION, FOR PROJECTS THAT WILL DISTURB 1 ACRE OR MORE, THE OWNER OR OPERATOR OF THE CONSTRUCTION ACTIVITY SHALL SUBMIT A PERMIT APPLICATION FOR STORMWATER DISCHARGE TO THE COLORADO DEPARTMENT OF PUBLIC HEALTH AND ENVIRONMENT, WATER QUALITY CONTROL DIVISION. THE APPLICATION CONTAINS CERTIFICATION OF COMPLETION OF A STORMWATER MANAGEMENT PLAN (SWMP), OF WHICH THIS GRADING AND EROSION CONTROL PLAN MAY BE A PART. FOR INFORMATION OR APPLICATION MATERIALS CONTACT: COLORADO DEPARTMENT OF PUBLIC HEALTH AND ENVIRONMENT WATER QUALITY CONTROL DIVISION WOOD - PERMITS 4300 CHERRY CREEK DRIVE SOUTH DENVER, CO 80246-1530 ATTN: PERMITS UNIT
- 2. SOIL EROSION CONTROL MEASURES FOR ALL SLOPES, CHANNELS, DITCHES, OR ANY DISTURBED LAND AREA SHALL BE COMPLETED WITHIN TWENTY-ONE (21) CALENDAR DAYS AFTER FINAL GRADING, OR FINAL EARTH DISTURBANCE HAS BEEN COMPLETED. DISTURBED AREAS AND STOCKPILES WHICH ARE NOT AT FINAL GRADE BUT WILL REMAIN DORMANT FOR LONGER THAN 30 DAYS SHALL ALSO BE MULCHED WITHIN 21 DAYS AFTER INTERIM GRADING. AN AREA THAT IS GOING TO REMAIN IN AN INTERM STATE FOR MORE THAN 60 DAYS SHALL ALSO BE SEEDED. ALL TEMPORARY SOIL EROSION CONTROL MEASURES AND BMPs SHALL BE MAINTAINED UNTIL PERMANENT SOIL EROSION CONTROL MEASURES ARE IMPLEMENTED.
- 3. CONSTRUCTION FENCE AND SILT FENCE OFFSET FOR CLARITY. CONTRACTOR TO ENSURE BMPs ARE PLACED DOWNSTREAM OF DISTURBED AREAS TO PREVENT SEDIMENT FROM LEAVING THE SITE.
- 4. BENT GRASS MEADOWS DRIVE SHALL BE STREET SWEPT AND INSPECTED ON A REGULAR BASIS DURING CONSTRUCTION.
- 5. NO NOTABLE EXISTING VEGETATION EXISTS ON THE SITE, APART FROM NATIVE GRASSES AND WEEDS. THE EXISTING SOIL TYPES WITHIN THE PROPERTY CONSISTS OF COLUMBINE GRAVELLY SANDY LOAM, BLAKELAND-FLUVAQUENTIC HAPLXUOLLOLS, AND BLAKELAND LOAMY SAND. ALL SOILS ARE DEFINED AS HAVING A HYDROLOGIC SOIL GROUP OF A, AS DETERMINED BY THE NRCS WEB SOIL SURVEY FOR EL PASO COUNTY AREA.
- 6. NO BATCH PLANTS TO BE UTILIZED ONSITE.

GENERAL CONSTRUCTION NOTES

- 1. IT SHALL BE THE RESPONSIBILITY OF THE CONTRACTOR TO VERIFY THE EXISTENCE AND LOCATION OF ALL UNDERGROUND UTILITIES ALONG THE ROUTE OF THE WORK. THE OMISSION FROM OR THE INCLUSION OF UTILITY LOCATIONS ON THE PLANS IS NOT TO BE CONSIDERED AS THE NONEXISTENCE OF OR A DEFINITE LOCATION OF EXISTING UNDERGROUND UTILITIES.
- 2. THE CONTRACTOR SHALL TAKE THE NECESSARY PRECAUTIONS TO PROTECT EXISTING UTILITIES FROM DAMAGE DUE TO THIS OPERATION. ANY DAMAGE TO THE UTILITIES WILL BE REPLACED AT THE CONTRACTORS EXPENSE AND ANY SERVICE DISRUPTION WILL BE SETTLED BY THE CONTRACTOR.
- 3. ADDITIONAL EROSION CONTROL STRUCTURES MAY BE REQUIRED AT THE TIME OF CONSTRUCTION.
- 4. ALL BACKFILL, SUB-BASE AND / OR BASE COURSE (CLASS 6) MATERIAL SHALL BE COMPACTED TO THE SOILS ENGINEERS RECOMMENDATIONS, AND APPROVED BY EL PASO COUNTY DEVELOPMENT SERVICES ENGINEERING DIVISION.
- 5. ALL STATIONING IS CENTERLINE UNLESS OTHERWISE INDICATED. ALL ELEVATIONS ARE FLOW LINE UNLESS OTHERWISE INDICATED.
- 6. ALL DISTURBED PAVEMENT EDGES SHALL BE CUT TO NEAT LINES. REPAIR SHALL CONFORM TO THE EPC EOM APPENDIX K - 1.2c.
- 7. ALL INTERSECTION ACCESSES TO BE CONSTRUCTED WITH A 25 FOOT SIGHT VISIBILITY TRIANGLES AND THERE SHALL BE NO OBSTRUCTIONS GREATER THAN 18" IN THIS AREA.
- 8. ALL CULVERT AND STORM PIPES SHALL BE SMOOTH INTERIOR CORRUGATED POLYETHYLENE PIPE (HDPE), OR REINFORCED CONCRETE PIPE (RCP). ALL CULVERTS SHALL BE PLACED COMPLETE WITH FLARED END SECTIONS. ADEQUACY OF MATERIAL THICKNESS FOR ANY CSP INSTALLED SHALL BE VERIFIED BY OWNERS GEOTECHNICAL ENGINEER TO SUPPORT MINIMUM 50 YEAR DESIGN LIFE. CULVERTS MUST CONFORM TO EPC EOM SECTION 3.32 - CULVERTS.
- 9. ASPHALT THICKNESS AND BASE COURSE THICKNESS (COMPACTED FOR ROADS SHALL BE PER DESIGN REPORT BY OWNERS GEOTECHNICAL ENGINEER, OWNERS GEOTECHNICAL ENGINEER TO BE ON SITE AT TIME OF ROAD CONSTRUCTION TO EVALUATE SOIL CONDITIONS AND DETERMINE IF ADDITIONAL MEASURES ARE NECESSARY TO ASSURE STABILITY OF THE NEW ROADS. PAVEMENT DESIGN SHALL BE APPROVED BY EL PASO COUNTY DEVELOPMENT SERVICES ENGINEERING DIVISION PRIOR TO CONSTRUCTION.
- 10. TYPE II RIP-RAP WITH 4" OF TYPE II GRANULAR BEDDING AND MRRAP 180N OR EQUAL MAY BE SUBSTITUTED WHERE TYPE I RIP-RAP WITH MRRAP FW 700 OR EQUAL IS SPECIED.
- 11. ALL MATERIALS AND INSTALLATION PROCEDURES SHALL BE IN COMPLIANCE WITH ANY AND ALL APPLICABLE EL PASO COUNTY STANDARDS AND WITH WOODMAN HILLS METRO DISTRICT CONSULTING ENGINEER APPROVAL.
- 12. ALL POTABLE WATER MAINS SHALL BE AWWA C900-SDR18 PVC WITH PUSH-ON SINGLE GASKET TYPE JOINTS AND SHALL MEET THE REQUIREMENTS OF ANSI / NSF 61.
- 13. ALL WATER MAIN FITTINGS SHALL BE MADE FROM GRAY-IRON OR DUCTILE IRON AND FURNISHED WITH MECHANICAL JOINT ENDS. ALL FITTINGS SHALL HAVE A PRESSURE RATING OF 250 PSI AND SHALL MEET THE REQUIREMENTS OF ANSI / NSF 61.
- 14. ALL WATER LINE BENDS, TEES, BLOW-OFFS AND PLUGS AT DEAD-END MAINS SHALL BE PROTECTED FROM THRUST BY USING CONCRETE THRUST BLOCKS AND / OR RODDING AND RESTRAINED PIPE PER THE WOODMAN HILLS METRO DISTRICT CONSULTING ENGINEER APPROVAL.
- 15. MAXIMUM DEFLECTION OF 8" OR 12" PVC WATER MAIN JOINTS IS 4 DEGREES. CORRESPONDING MINIMUM CURVE RADIUS IS 286'. ADDITIONAL 11.25' OR 22.5' BENDS MAY BE REQUIRED FOR PROPER ALIGNMENT.
- 16. CONTRACTOR IS RESPONSIBLE FOR PROVIDING DETAILED AS-BUILTS OF ALL WATER MAIN, STORM SEWER AND SANITARY SEWER MAIN INSTALLATIONS, INCLUDING ACCURATE DISTANCES OF MAIN LINES, VALVES, FITTINGS, MANHOLES AND LOCATIONS OF WATER AND SEWER SERVICES.
- 17. SANITARY SEWER PIPE AND FITTINGS: PVC 4" - 8" ASTM D3034, TYPE PSM, SDR 35; PUSH-ON JOINTS AND MOLDED RUBBER GASKETS MAXIMUM HORIZONTAL DEFLECTIONS, AFTER INSTALLATION AND BACK FILLING SHALL NOT EXCEED 3% OF THE PIPE DIAMETER. (MINIMUM CURVE RADIUS IS 100' FOR 8" PVC SANITARY SEWER MAIN)



COPYRIGHT THESE PLANS ARE AN INSTRUMENT OF SERVICE AND ARE THE PROPERTY OF GALLOWAY, AND MAY NOT BE DUPLICATED, DISCLOSED, OR REPRODUCED WITHOUT THE WRITTEN CONSENT OF GALLOWAY. COPYRIGHTS AND REFINEMENTS WILL BE ENFORCED AND PROSECUTED.



GRADING & EROSION CONTROL PLANS CONSTITUTION STORAGE JOHNSON DEVELOPMENT ASSOCIATES 2460 CANADA DRIVE COLORADO SPRINGS, CO 80915

Table with 4 columns: #, Date, Issue / Description, Init. It contains a series of empty rows for tracking changes.

Project No: JDA02 Drawn By: BLB Checked By: BAS Date: JULY 2023

GRADING & EROSION CONTROL NOTES



**COPYRIGHT**  
 THESE PLANS ARE AN INSTRUMENT OF SERVICE AND ARE THE PROPERTY OF GALLOWAY, AND MAY NOT BE DUPLICATED, DISCLOSED, OR REPRODUCED WITHOUT THE WRITTEN CONSENT OF GALLOWAY. COPYRIGHTS AND INFRINGEMENTS WILL BE ENFORCED AND PROSECUTED.



**GRADING & EROSION CONTROL PLANS  
 CONSTITUTION STORAGE**  
**JOHNSON DEVELOPMENT ASSOCIATES**  
 2460 CANADA DRIVE  
 COLORADO SPRINGS, CO 80915

#	Date	Issue / Description	Init.

Project No: JDA02  
 Drawn By: BLB  
 Checked By: BAS  
 Date: JULY 2023

**GRADING & EROSION CONTROL INITIAL PLAN**

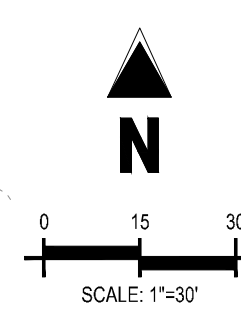
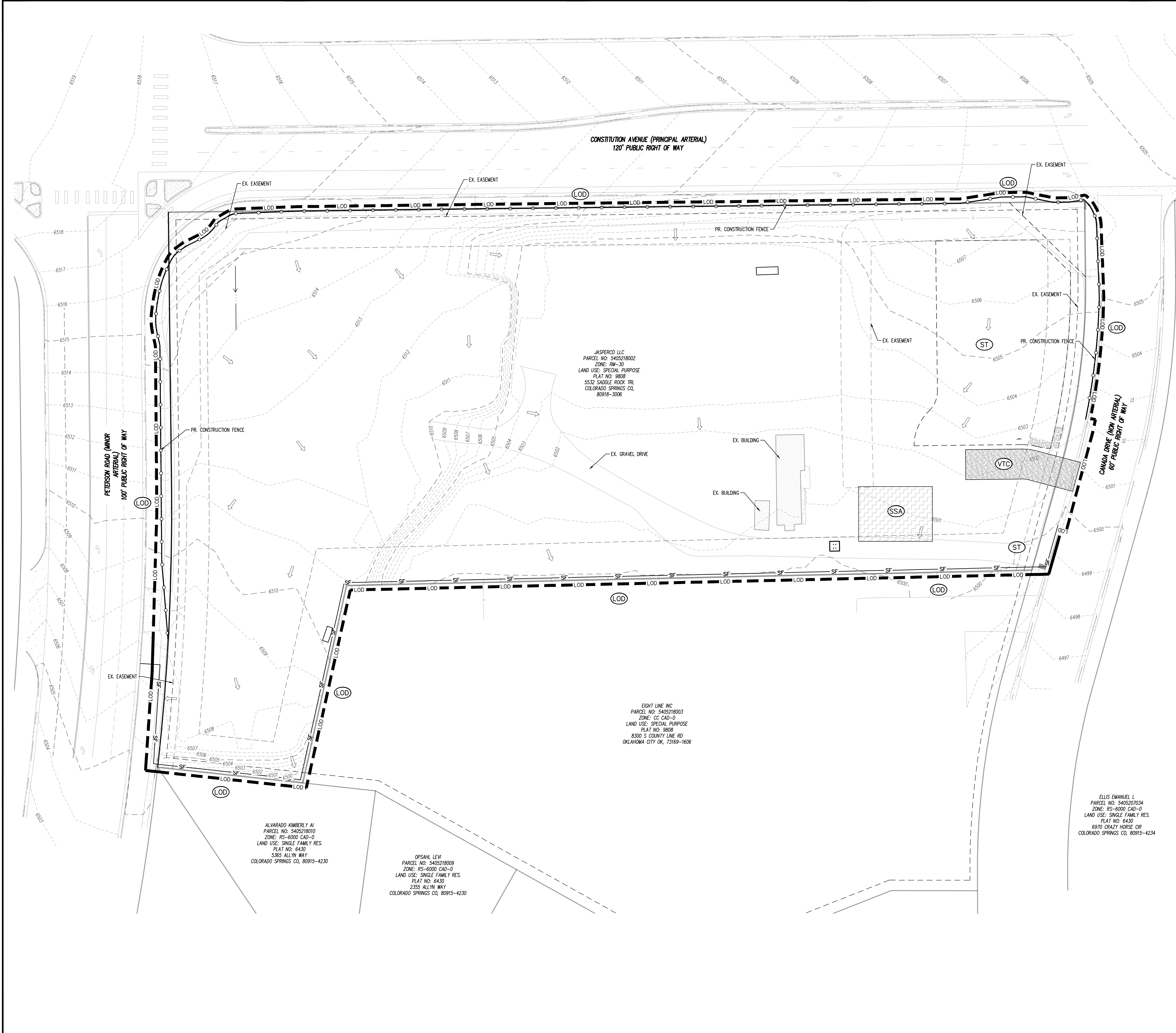

EROSION CONTROL PHASING SCHEDULE	
PHASE	DESCRIPTION
INITIAL	INSTALL VEHICLE TRACKING CONTROL, SILT & CONSTRUCTION FENCE.
INTERIM	CONVERT EXISTING SEDIMENT BASIN FROM "EARLY GRADING & EROSION CONTROL PLANS" TO THE PROPOSED WATER QUALITY CAPTURE VOLUME DETENTION BASIN W/ ALL PERMANENT CONTROL MEASURES. THEN, INSTALL STABILIZED STAGING AREA, TEMPORARY SEDIMENT BASIN, AND CONCRETE WASHOUT AREA. THEN OVERLOT GRADE THE ENTIRE PROJECT SITE AS SHOWN ON PLAN VIEW. INSTALL CHECK DAMS ALONG PROPOSED SWALES. FINALLY, INSTALL PROPOSED STORM SEWER. CONTRACTOR TO USE EXTREME CAUTION TO NOT DAMAGE THE WATER AND WASTEWATER IMPROVEMENTS COMPLETED IN THE EARLY METRO DISTRICT IMPROVEMENTS PLAN SET.
FINAL	CONSTRUCT CURB/GUTTER AND PAVEMENT. CONSTRUCT GAS/ELECTRIC/CABLE/PHONE IN ROW AREAS. REMOVE CONSTRUCTION BMP'S ONCE VERTICAL CONSTRUCTION AND APPLICABLE LANDSCAPING IS COMPLETE.

**LEGEND**

- EXISTING PROPERTY LINE (PROJECT BOUNDARY)
- - - EXISTING PROPERTY LINE
- - - EXISTING CENTER LINE
- - - PROPOSED CENTER LINE
- - - EXISTING RIGHT OF WAY LINE
- - - EXISTING CONCRETE PAVING
- - - EXISTING GRAVEL ROAD
- - - PROPOSED CONSTRUCTION FENCE
- - - EXISTING EASEMENT
- - - EXISTING MAJOR CONTOUR
- - - EXISTING MINOR CONTOUR
- - - EXISTING WATER LINE
- - - EXISTING SANITARY SEWER LINE
- - - EXISTING DRAINAGE FEATURE OUTLINE
- - - EXISTING SWALE WITH FLOW DIRECTION
- - - EXISTING FIBER OPTIC
- - - EXISTING UNDERGROUND ELECTRIC
- - - EXISTING FENCE

**EROSION CONTROL LEGEND**

- LOD LIMITS OF DISTURBANCE/ CONSTRUCTION SITE BOUNDARY
- SF SILT FENCE
- ST SEDIMENT TRAP
- VTC VEHICLE TRACKING CONTROL
- SSA STABILIZED STAGING AREA
- EXISTING FLOW

**NOTES**

- THE PLAN SHALL NOT SUBSTANTIALLY CHANGE THE DEPTH OF COVER, OR ACCESS TO UTILITY FACILITIES. ADDITIONALLY, THE PLAN SHALL NOT INCREASE OR DIVERT WATER TOWARDS UTILITY FACILITIES. ANY CHANGES TO UTILITY FACILITIES TO ACCOMMODATE THE PLAN MUST BE DISCUSSED AND APPROVED TO BY THE AFFECTED UTILITY PRIOR TO IMPLEMENTING THE PLAN. THE RESULTING COST TO RELOCATE OR PROTECT UTILITIES, OR PROVIDE INTERIM ACCESS IS AT THE EXPENSE OF THE PLAN APPLICANT.

**BASIS OF BEARINGS**

BASIS OF BEARINGS: ALL BEARINGS ARE GRID BEARINGS OF THE COLORADO STATE PLANE COORDINATE SYSTEM, CENTRAL ZONE, NORTH AMERICAN DATUM 1983. THE NORTH LINE OF THE NORTHWEST QUARTER OF SECTION 5, TOWNSHIP 14 SOUTH, RANGE 65 WEST BEARS N89°27'41"E, MONUMENTED BY THE NORTHWEST CORNER OF SAID SECTION 5, BEING A 3-1/4" ALUMINUM CAP STAMPED "PLS 4842 1985" IN RANGE BOX, AND BY THE NORTH QUARTER CORNER OF SAID SECTION 5, BEING A 3-1/4" ALUMINUM CAP STAMPED "PLS 30829 2003", AS SHOWN HEREON.

**BENCHMARK**

COLORADO SPRINGS UTILITIES FACILITIES INFORMATION MANAGEMENT SYSTEM (FIMS) BENCHMARK SPOT BEING A 2" ALUMINUM CAP STAMPED "CSU FIMS CONTROL SP007" AT THE SOUTHEAST CORNER OF THE CONCRETE BASE FOR AN ELECTRIC VAULT ON THE WEST SIDE OF PETERSON ROAD, ABOUT 360' SOUTH OF THE CENTER LINE OF LEOTI DRIVE.

FIMS DATUM ELEVATION = 6534.61

**CAUTION - NOTICE TO CONTRACTOR**

- ALL UTILITY LOCATIONS SHOWN ARE BASED ON MAPS PROVIDED BY THE APPROPRIATE UTILITY COMPANY AND FIELD SURFACE EVIDENCE AT THE TIME OF SURVEY AND IS TO BE CONSIDERED AN APPROXIMATE LOCATION ONLY. IT IS THE CONTRACTOR'S RESPONSIBILITY TO FIELD VERIFY THE LOCATION OF ALL UTILITIES, PUBLIC OR PRIVATE, WHETHER SHOWN ON THE PLANS OR NOT, PRIOR TO CONSTRUCTION. REPORT ANY DISCREPANCIES TO THE ENGINEER PRIOR TO CONSTRUCTION.
- WHERE A PROPOSED UTILITY CROSSES AN EXISTING UTILITY, IT IS THE CONTRACTOR'S RESPONSIBILITY TO FIELD VERIFY THE HORIZONTAL AND VERTICAL LOCATION OF SUCH EXISTING UTILITY, EITHER THROUGH POT-HOLING OR ALTERNATIVE METHOD. REPORT INFORMATION TO THE ENGINEER PRIOR TO CONSTRUCTION.



CONSTITUTION AVENUE (PRINCIPAL ARTERIAL)  
 120' PUBLIC RIGHT OF WAY

PETERSON ROAD (MINOR ARTERIAL)  
 100' PUBLIC RIGHT OF WAY

CANADA DRIVE (NON ARTERIAL)  
 60' PUBLIC RIGHT OF WAY

JASPERO LLC  
 PARCEL NO: 5405218002  
 ZONE: RM-30  
 LAND USE: SPECIAL PURPOSE  
 PLAT NO: 9808  
 5532 SADDLE ROCK TRL  
 COLORADO SPRINGS CO,  
 80916-3006

EIGHT LINE INC  
 PARCEL NO: 5405218003  
 ZONE: CC CAD-0  
 LAND USE: SPECIAL PURPOSE  
 PLAT NO: 9808  
 8300 S COUNTY LINE RD  
 OKLAHOMA CITY OK, 73169-1606

ALVARADO KIMBERLY AI  
 PARCEL NO: 5405218010  
 ZONE: RS-6000 CAD-0  
 LAND USE: SINGLE FAMILY RES.  
 PLAT NO: 6430  
 5365 ALLYN WAY  
 COLORADO SPRINGS CO, 80915-4230

OPSAHL LEVI  
 PARCEL NO: 5405218009  
 ZONE: RS-6000 CAD-0  
 LAND USE: SINGLE FAMILY RES.  
 PLAT NO: 6430  
 2355 ALLYN WAY  
 COLORADO SPRINGS CO, 80915-4230

ELLIS EMANUEL L  
 PARCEL NO: 5405207034  
 ZONE: RS-6000 CAD-0  
 LAND USE: SINGLE FAMILY RES.  
 PLAT NO: 6430  
 6970 CRAZY HORSE CR  
 COLORADO SPRINGS CO, 80915-4234

15/07/2023 10:00:00 AM G:\Projects\2023\230701\230701\_G1.1\_InitialPlan.dwg User: JDA02



**COPYRIGHT**  
 THESE PLANS ARE AN INSTRUMENT OF SERVICE AND ARE THE PROPERTY OF GALLOWAY, AND MAY NOT BE DUPLICATED, DISCLOSED, OR REPRODUCED WITHOUT THE WRITTEN CONSENT OF GALLOWAY. COPYRIGHTS AND INFRINGEMENTS WILL BE ENFORCED AND PROSECUTED.



**GRADING & EROSION CONTROL PLANS  
 CONSTITUTION STORAGE**  
**JOHNSON DEVELOPMENT ASSOCIATES**  
 2460 CANADA DRIVE  
 COLORADO SPRINGS, CO 80915

#	Date	Issue / Description	Init.

Project No: JDA02  
 Drawn By: BLB  
 Checked By: BAS  
 Date: JULY 2023

**GRADING & EROSION CONTROL INTERIM PLAN**

**G2.1**  
 Sheet 4 of 11

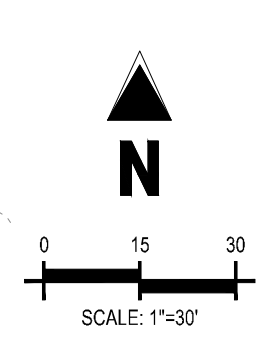
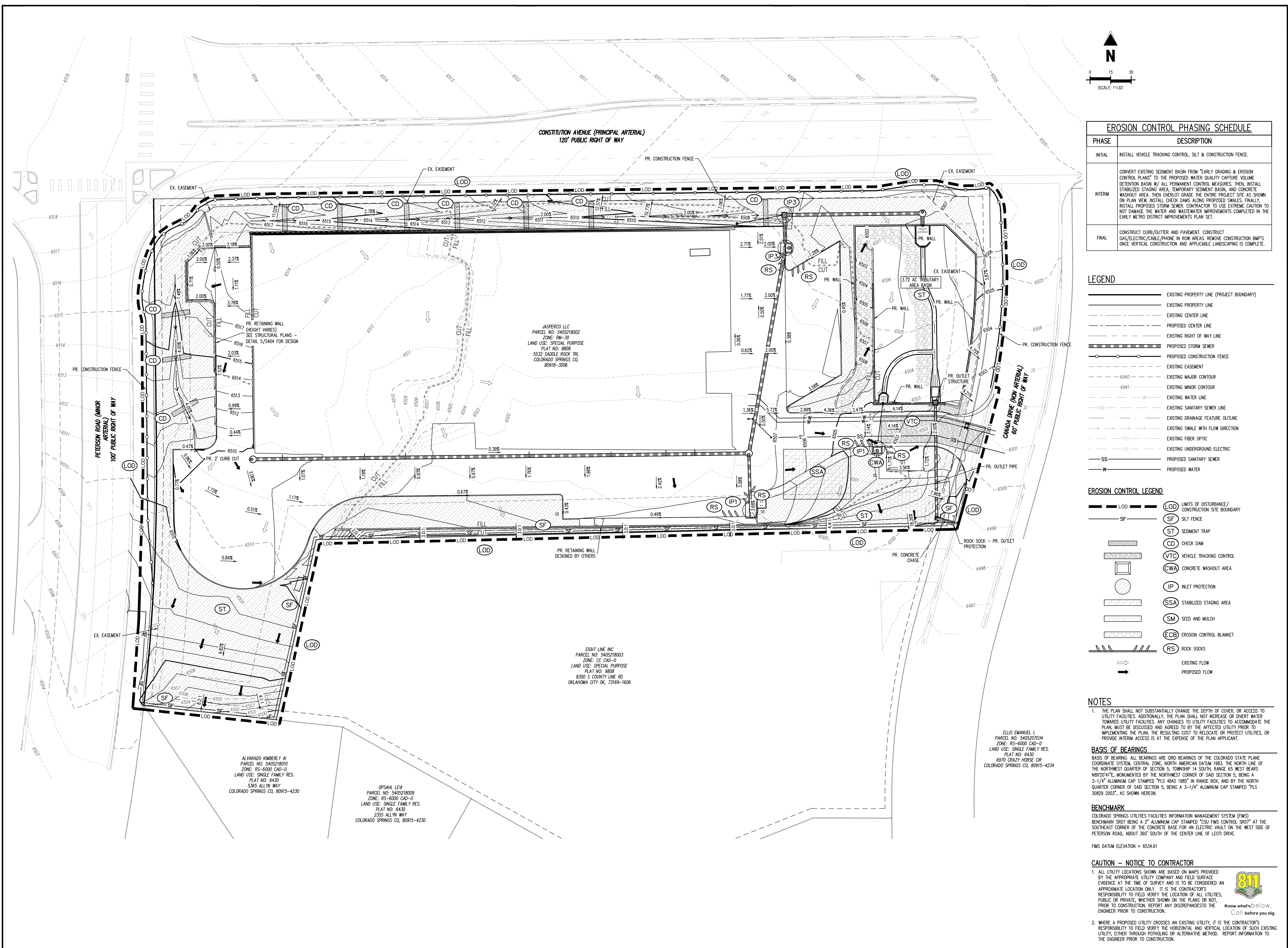

EROSION CONTROL PHASING SCHEDULE	
PHASE	DESCRIPTION
INITIAL	INSTALL VEHICLE TRACKING CONTROL, SILT & CONSTRUCTION FENCE.
INTERIM	CONVERT EXISTING SEDIMENT BASIN FROM "EARLY GRADING & EROSION CONTROL PLANS" TO THE PROPOSED WATER QUALITY CAPTURE VOLUME DETENTION BASIN W/ ALL PERMANENT CONTROL MEASURES. THEN, INSTALL STABILIZED STAGING AREA, TEMPORARY SEDIMENT BASIN, AND CONCRETE WASHOUT AREA. THEN OVERLAP GRADE THE ENTIRE PROJECT SITE AS SHOWN ON PLAN VIEW. INSTALL CHECK DAMS ALONG PROPOSED SWALES. FINALLY, INSTALL PROPOSED STORM SEWER. CONTRACTOR TO USE EXTREME CAUTION TO NOT DAMAGE THE WATER AND WASTEWATER IMPROVEMENTS COMPLETED IN THE EARLY METRO DISTRICT IMPROVEMENTS PLAN SET.
FINAL	CONSTRUCT CURB/GUTTER AND PAVEMENT. CONSTRUCT GAS/ELECTRIC/CABLE/PHONE IN ROW AREAS. REMOVE CONSTRUCTION BMP'S ONCE VERTICAL CONSTRUCTION AND APPLICABLE LANDSCAPING IS COMPLETE.

LEGEND	
(Symbol)	EXISTING PROPERTY LINE (PROJECT BOUNDARY)
(Symbol)	EXISTING PROPERTY LINE
(Symbol)	EXISTING CENTER LINE
(Symbol)	PROPOSED CENTER LINE
(Symbol)	EXISTING RIGHT OF WAY LINE
(Symbol)	PROPOSED STORM SEWER
(Symbol)	PROPOSED CONSTRUCTION FENCE
(Symbol)	EXISTING EASEMENT
(Symbol)	EXISTING MAJOR CONTOUR
(Symbol)	EXISTING MINOR CONTOUR
(Symbol)	EXISTING WATER LINE
(Symbol)	EXISTING SANITARY SEWER LINE
(Symbol)	EXISTING DRAINAGE FEATURE OUTLINE
(Symbol)	EXISTING SWALE WITH FLOW DIRECTION
(Symbol)	EXISTING FIBER OPTIC
(Symbol)	EXISTING UNDERGROUND ELECTRIC
(Symbol)	PROPOSED SANITARY SEWER
(Symbol)	PROPOSED WATER

EROSION CONTROL LEGEND	
(Symbol)	LOD LIMITS OF DISTURBANCE/ CONSTRUCTION SITE BOUNDARY
(Symbol)	SF SILT FENCE
(Symbol)	ST SEDIMENT TRAP
(Symbol)	CD CHECK DAM
(Symbol)	VTC VEHICLE TRACKING CONTROL
(Symbol)	CWA CONCRETE WASHOUT AREA
(Symbol)	IP INLET PROTECTION
(Symbol)	SSA STABILIZED STAGING AREA
(Symbol)	SM SEED AND MULCH
(Symbol)	ECB EROSION CONTROL BLANKET
(Symbol)	RS ROCK SOCKS
(Symbol)	EXISTING FLOW
(Symbol)	PROPOSED FLOW

**NOTES**  
 1. THE PLAN SHALL NOT SUBSTANTIALLY CHANGE THE DEPTH OF COVER, OR ACCESS TO UTILITY FACILITIES. ADDITIONALLY, THE PLAN SHALL NOT INCREASE OR DIVERT WATER TOWARDS UTILITY FACILITIES. ANY CHANGES TO UTILITY FACILITIES TO ACCOMMODATE THE PLAN, MUST BE DISCUSSED AND AGREED TO BY THE AFFECTED UTILITY PRIOR TO IMPLEMENTING THE PLAN. THE RESULTING COST TO RELOCATE OR PROTECT UTILITIES, OR PROVIDE INTERIM ACCESS IS AT THE EXPENSE OF THE PLAN APPLICANT.

**BASIS OF BEARINGS**  
 BASIS OF BEARING: ALL BEARINGS ARE GRID BEARINGS OF THE COLORADO STATE PLANE COORDINATE SYSTEM, CENTRAL ZONE, NORTH AMERICAN DATUM 1983. THE NORTH LINE OF THE NORTHWEST QUARTER OF SECTION 5, TOWNSHIP 14 SOUTH, RANGE 65 WEST BEARS N89°27'41"E, MONUMENTED BY THE NORTHWEST CORNER OF SAID SECTION 5, BEING A 3-1/4" ALUMINUM CAP STAMPED "PLS 4842 1985" IN RANGE BOX, AND BY THE NORTH QUARTER CORNER OF SAID SECTION 5, BEING A 3-1/4" ALUMINUM CAP STAMPED "PLS 30829 2003", AS SHOWN HEREON.

**BENCHMARK**  
 COLORADO SPRINGS UTILITIES FACILITIES INFORMATION MANAGEMENT SYSTEM (FIMS) BENCHMARK SPOT BEING A 2" ALUMINUM CAP STAMPED "CSU FIMS CONTROL SPOT7" AT THE SOUTHEAST CORNER OF THE CONCRETE BASE FOR AN ELECTRIC VAULT ON THE WEST SIDE OF PETERSON ROAD, ABOUT 360' SOUTH OF THE CENTER LINE OF LEOTI DRIVE.

FIMS DATUM ELEVATION = 6534.61

**CAUTION - NOTICE TO CONTRACTOR**  
 1. ALL UTILITY LOCATIONS SHOWN ARE BASED ON MAPS PROVIDED BY THE APPROPRIATE UTILITY COMPANY AND FIELD SURFACE EVIDENCE AT THE TIME OF SURVEY AND IS TO BE CONSIDERED AN APPROXIMATE LOCATION ONLY. IT IS THE CONTRACTOR'S RESPONSIBILITY TO FIELD VERIFY THE LOCATION OF ALL UTILITIES, PUBLIC OR PRIVATE, WHETHER SHOWN ON THE PLANS OR NOT, PRIOR TO CONSTRUCTION. REPORT ANY DISCREPANCIES TO THE ENGINEER PRIOR TO CONSTRUCTION.

2. WHERE A PROPOSED UTILITY CROSSES AN EXISTING UTILITY, IT IS THE CONTRACTOR'S RESPONSIBILITY TO FIELD VERIFY THE HORIZONTAL AND VERTICAL LOCATION OF SUCH EXISTING UTILITY, EITHER THROUGH POT-HOLING OR ALTERNATIVE METHOD. REPORT INFORMATION TO THE ENGINEER PRIOR TO CONSTRUCTION.







**COPYRIGHT**  
 THESE PLANS ARE AN INSTRUMENT OF SERVICE AND ARE THE PROPERTY OF GALLOWAY, AND MAY NOT BE DUPLICATED, DISCLOSED, OR REPRODUCED WITHOUT THE WRITTEN CONSENT OF GALLOWAY. COPYRIGHTS AND INFRINGEMENTS WILL BE ENFORCED AND PROSECUTED.



**GRADING & EROSION CONTROL PLANS**  
**CONSTITUTION STORAGE**  
**JOHNSON DEVELOPMENT ASSOCIATES**  
 2460 CANADA DRIVE  
 COLORADO SPRINGS, CO 80915

#	Date	Issue / Description	Init.

Project No:	JDA02
Drawn By:	RWO
Checked By:	BAS
Date:	JULY 2023

**INTERSECTION DETAILS**

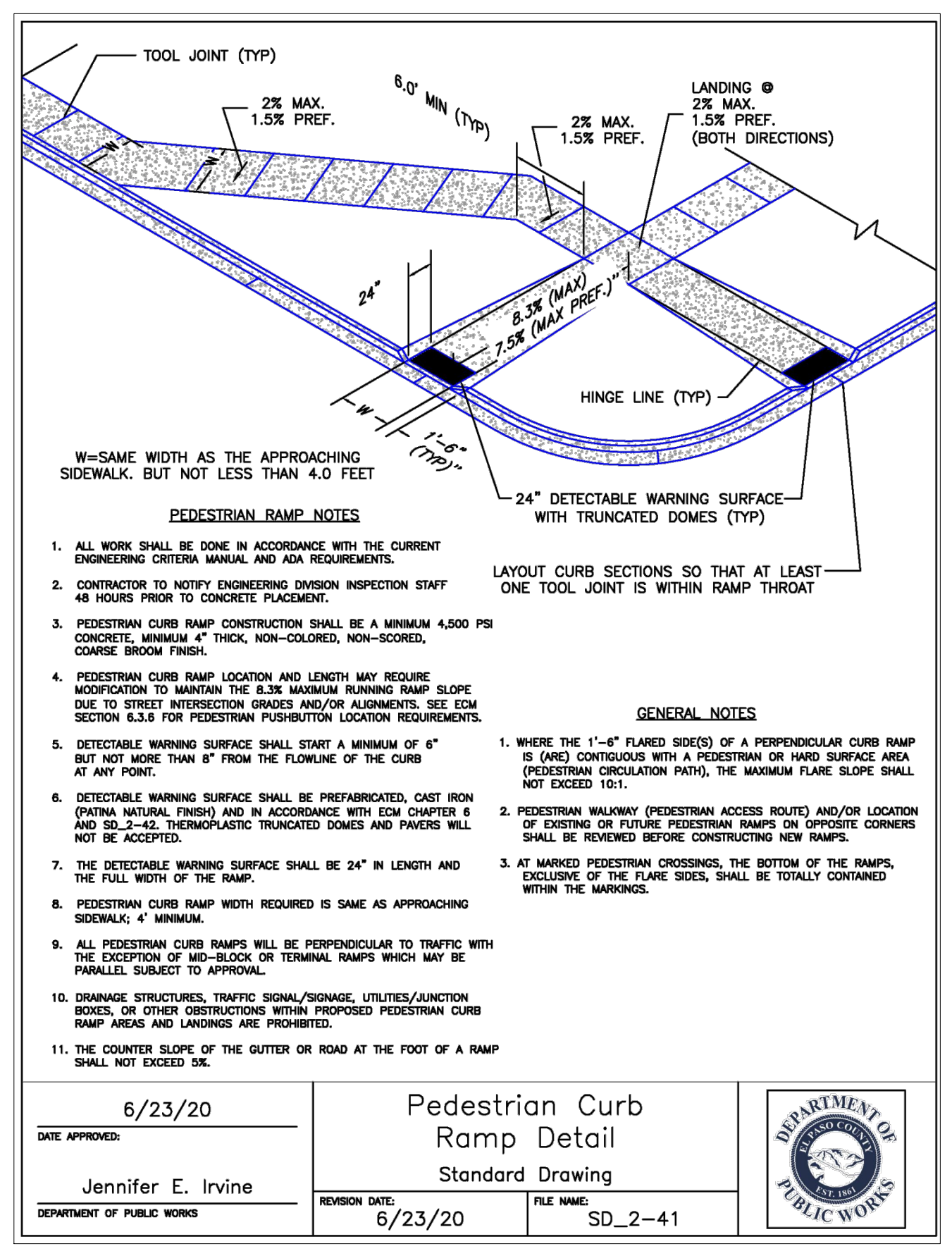
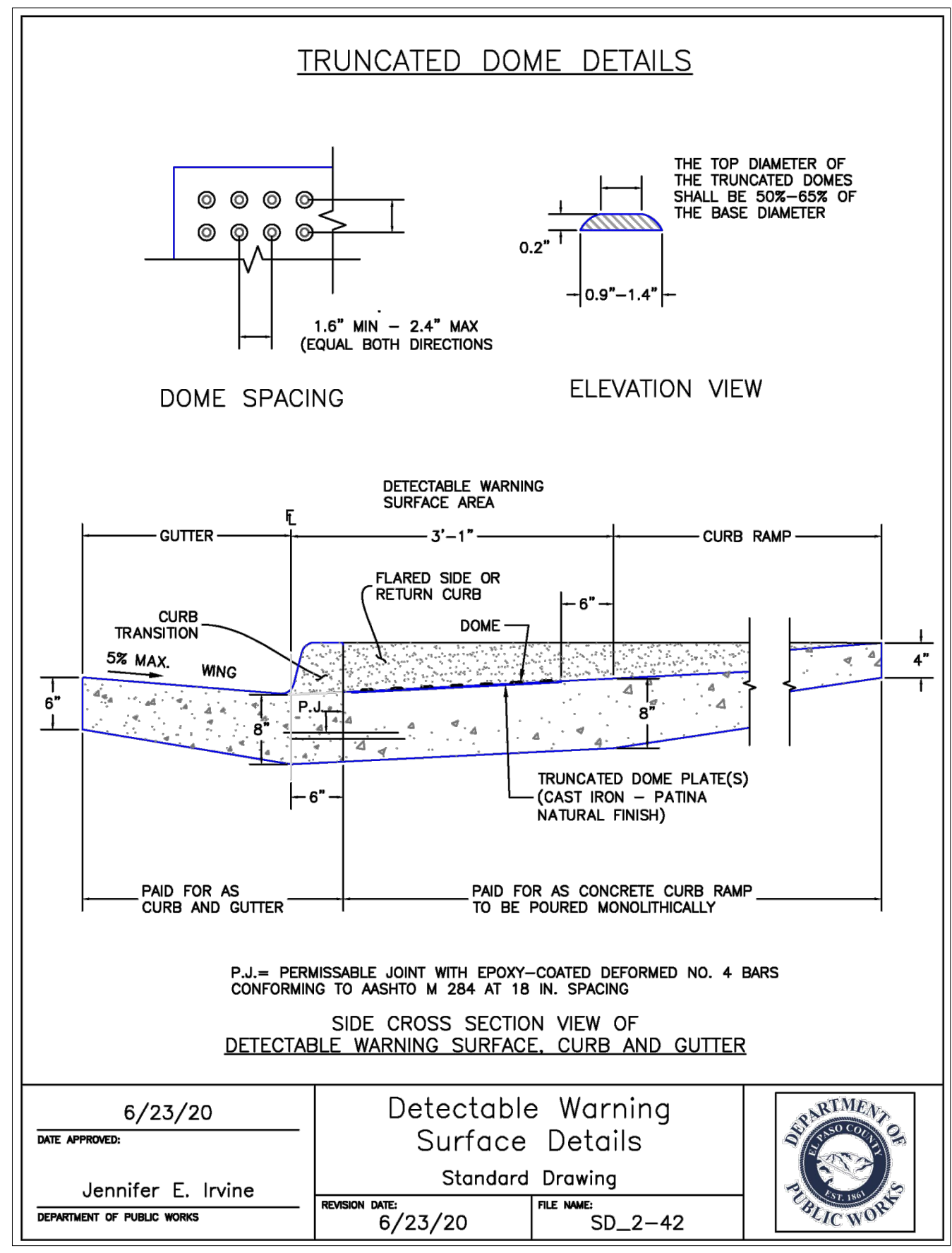
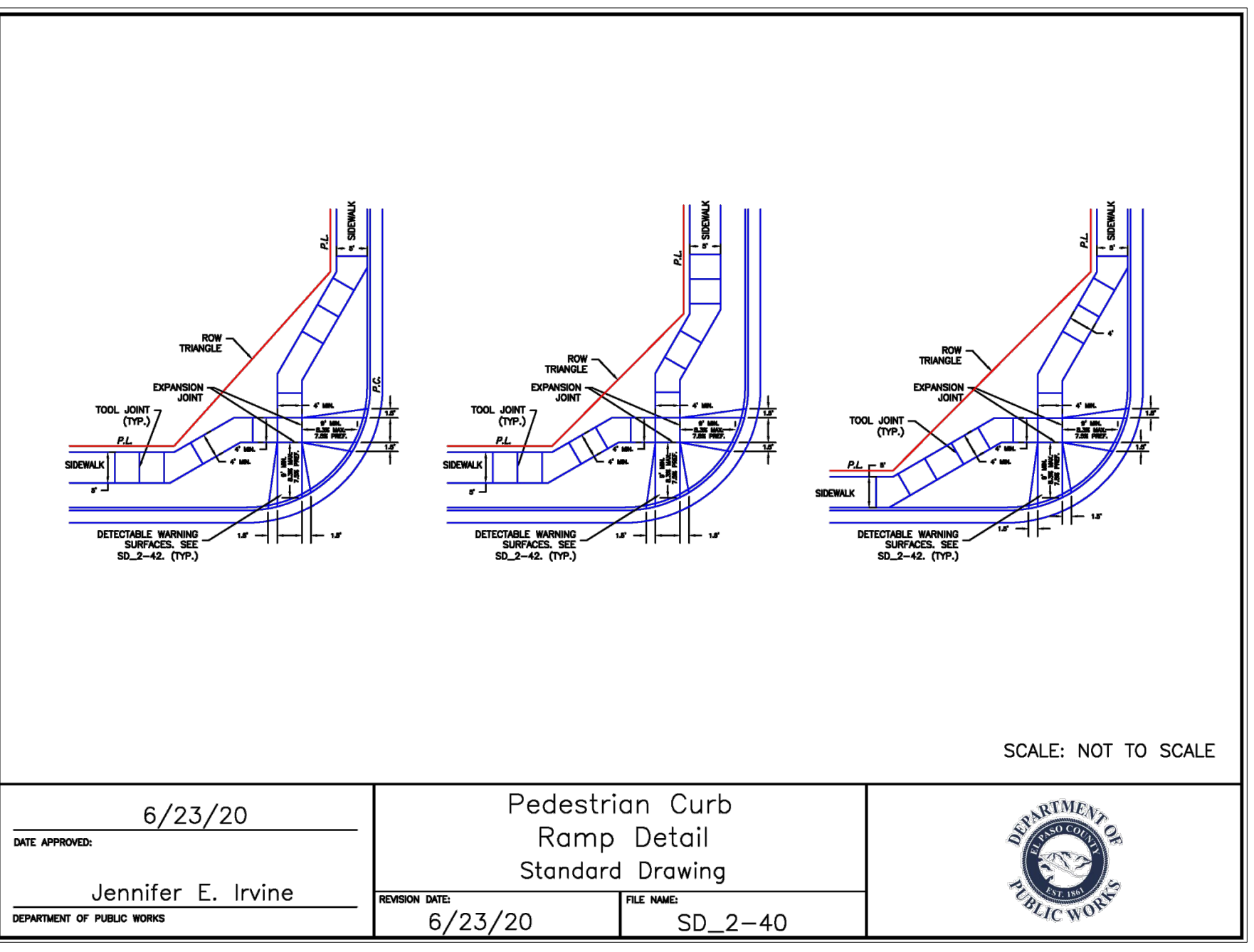
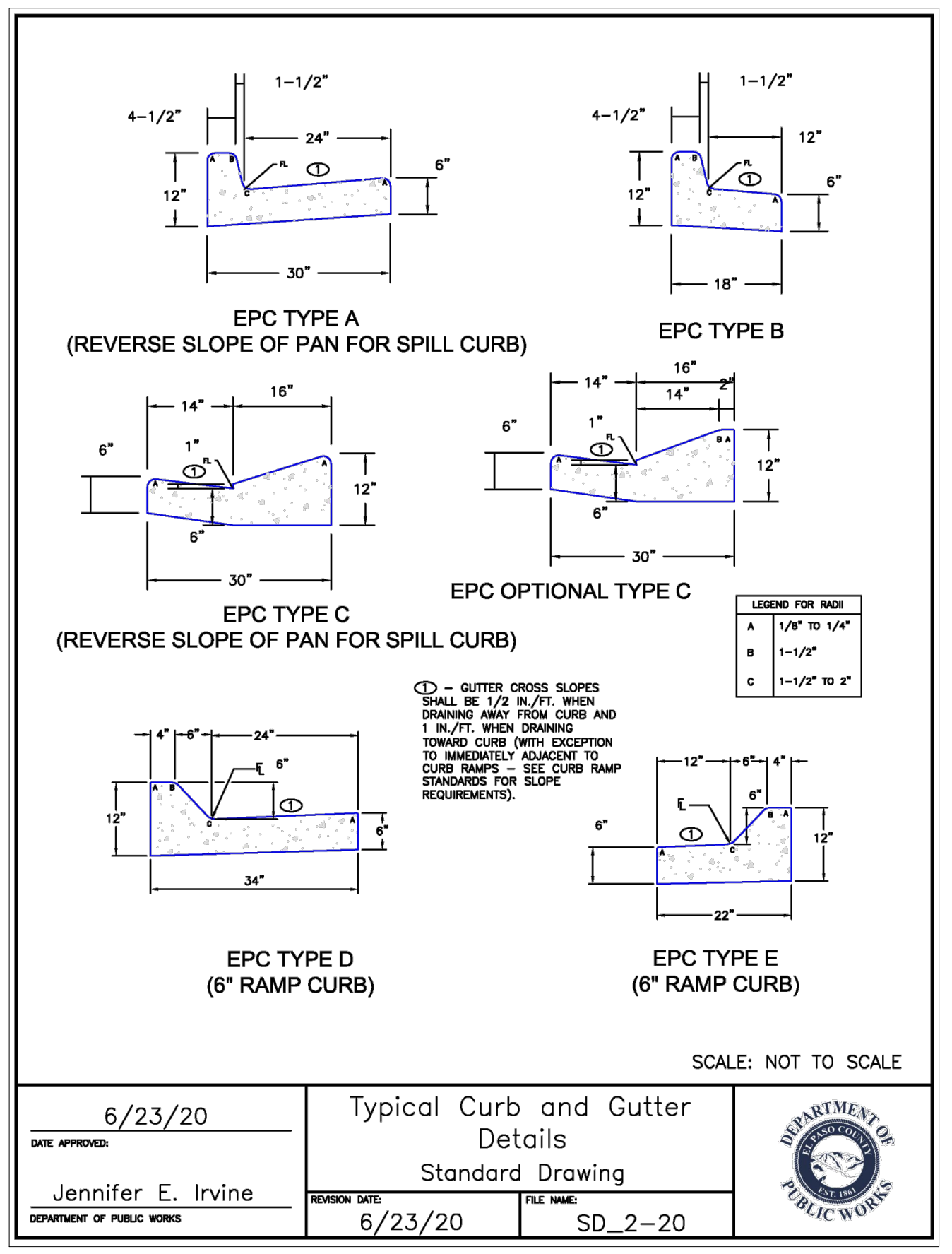

- PEDESTRIAN RAMP NOTES**
- ALL WORK SHALL BE DONE IN ACCORDANCE WITH THE CURRENT ENGINEERING CRITERIA MANUAL AND ADA REQUIREMENTS.
  - CONTRACTOR TO NOTIFY ENGINEERING DIVISION INSPECTION STAFF 48 HOURS PRIOR TO CONCRETE PLACEMENT.
  - PEDESTRIAN CURB RAMP CONSTRUCTION SHALL BE A MINIMUM 4,500 PSI CONCRETE, MINIMUM 4" THICK, NON-COLORED, NON-SCORED, COARSE BROOM FINISH.
  - PEDESTRIAN CURB RAMP LOCATION AND LENGTH MAY REQUIRE MODIFICATION TO MAINTAIN THE 8.3% MAXIMUM RUNNING RAMP SLOPE DUE TO STREET INTERSECTION GRADES AND/OR ALIGNMENTS. SEE EGM SECTION 8.3.6 FOR PEDESTRIAN PUSHBUTTON LOCATION REQUIREMENTS.
  - DETECTABLE WARNING SURFACE SHALL START A MINIMUM OF 6" BUT NOT MORE THAN 8" FROM THE FLOWLINE OF THE CURB AT ANY POINT.
  - DETECTABLE WARNING SURFACE SHALL BE PREFABRICATED, CAST IRON (PATINA NATURAL FINISH) AND IN ACCORDANCE WITH EGM CHAPTER 8 AND SD\_2-42. THERMOPLASTIC TRUNCATED DOMES AND PAVERS WILL NOT BE ACCEPTED.
  - THE DETECTABLE WARNING SURFACE SHALL BE 24" IN LENGTH AND THE FULL WIDTH OF THE RAMP.
  - PEDESTRIAN CURB RAMP WIDTH REQUIRED IS SAME AS APPROACHING SIDEWALK; 4' MINIMUM.
  - ALL PEDESTRIAN CURB RAMPS WILL BE PERPENDICULAR TO TRAFFIC WITH THE EXCEPTION OF MID-BLOCK OR TERMINAL RAMPS WHICH MAY BE PARALLEL, SUBJECT TO APPROVAL.
  - DRAINAGE STRUCTURES, TRAFFIC SIGNAL/STORAGE, UTILITIES/JUNCTION BOXES, OR OTHER OBSTRUCTIONS WITHIN PROPOSED PEDESTRIAN CURB RAMP AREAS AND LANDINGS ARE PROHIBITED.
  - THE COUNTER SLOPE OF THE GUTTER OR ROAD AT THE FOOT OF A RAMP SHALL NOT EXCEED 5%.
- GENERAL NOTES**
- WHERE THE 1'-8" FLARED SIDES OF A PERPENDICULAR CURB RAMP IS ADJACENT TO A PEDESTRIAN OR WALKWAY SURFACE AREA (PEDESTRIAN CIRCULATION PATH), THE MAXIMUM FLARE SLOPE SHALL NOT EXCEED 10:1.
  - PEDESTRIAN WALKWAY (PEDESTRIAN ACCESS ROUTE) AND/OR LOCATION OF EXISTING OR FUTURE PEDESTRIAN RAMPS ON OPPOSITE CORNERS SHALL BE REVIEWED BEFORE CONSTRUCTING NEW RAMPS.
  - AT MARKED PEDESTRIAN CROSSINGS, THE BOTTOM OF THE RAMPS, EXCLUSIVE OF THE FLARE SIDES, SHALL BE TOTALLY CONTAINED WITHIN THE MARKINGS.

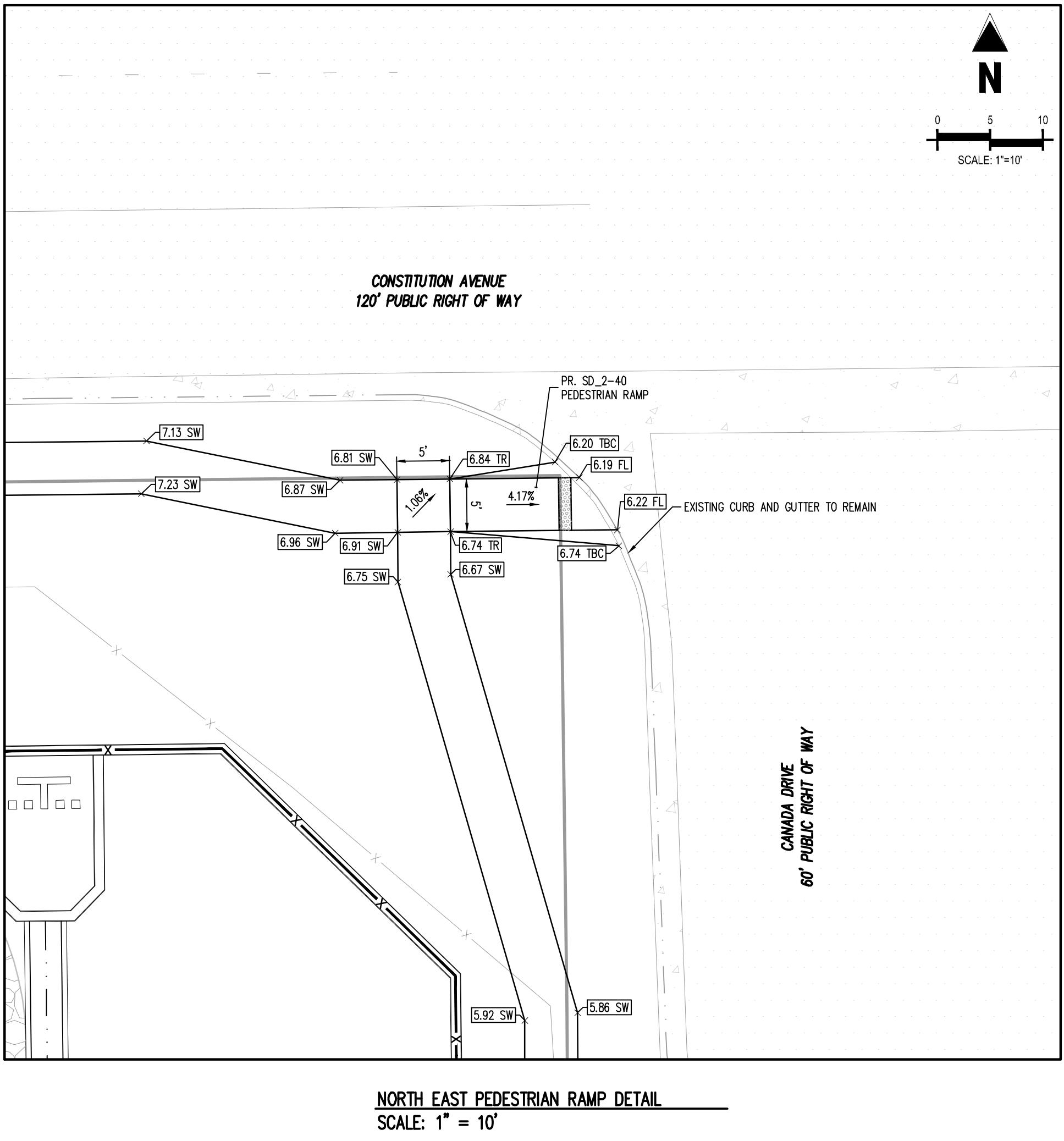
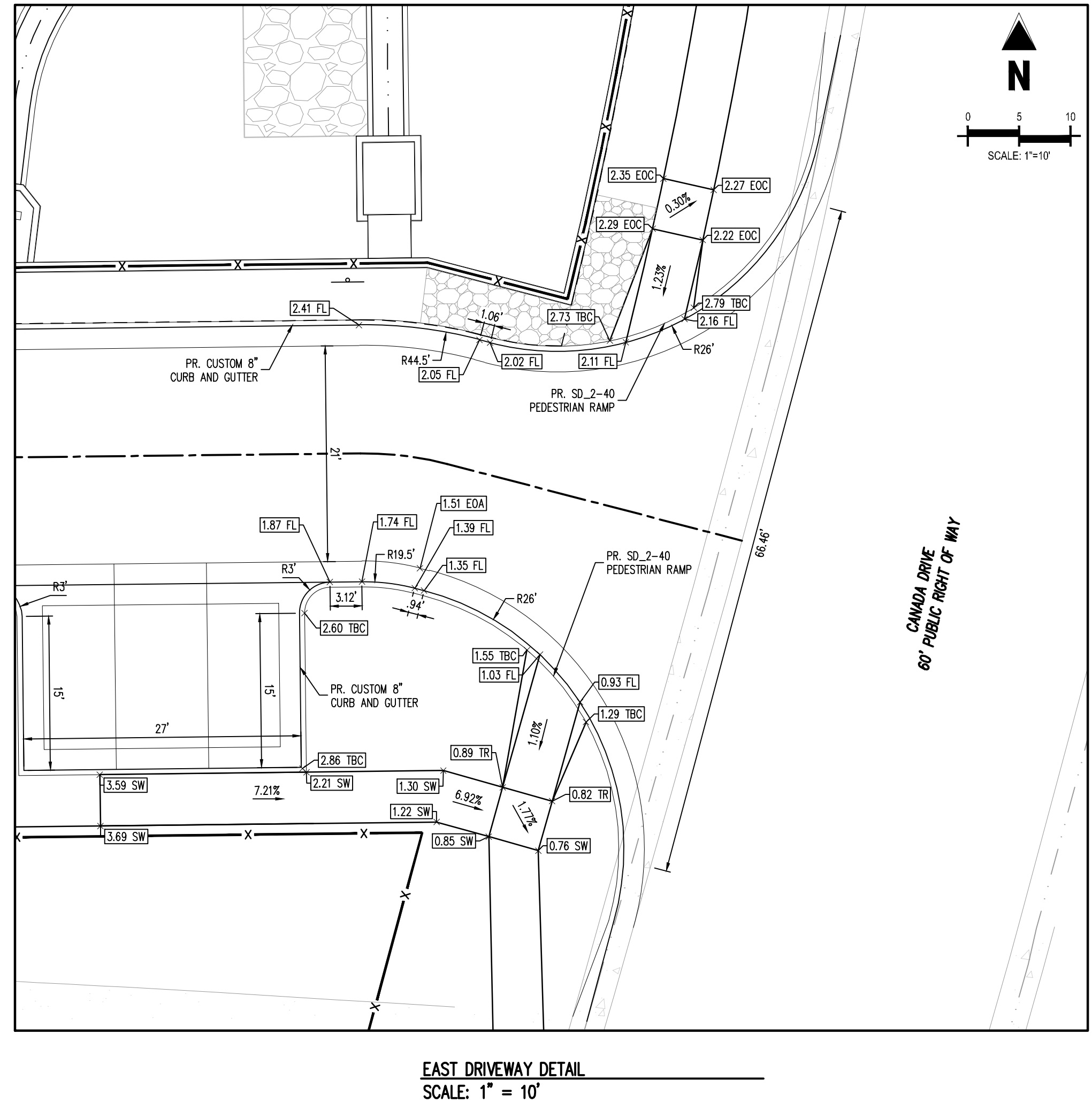

Vertical text on the left edge of the page, likely a project identifier or drawing number.

## **APPENDIX E**





Sediment Trap (ST)

SC-8

SEDIMENT TRAP INSTALLATION NOTES

- 1. SEE PLAN VIEW FOR: -LOCATION, LENGTH AND WIDTH OF SEDIMENT TRAP. 2. ONLY USE FOR DRAINAGE AREAS LESS THAN 1 ACRE. 3. SEDIMENT TRAPS SHALL BE INSTALLED PRIOR TO ANY UPGRADIENT LAND-DISTURBING ACTIVITIES. 4. SEDIMENT TRAP BERM SHALL BE CONSTRUCTED FROM MATERIAL FROM EXCAVATION. THE BERM SHALL BE COMPACTED TO 95% OF THE MAXIMUM DENSITY IN ACCORDANCE WITH ASTM D698. 5. SEDIMENT TRAP OUTLET TO BE CONSTRUCTED OF RIPRAP, TYPE M (D50=12") TYP. SMALLER ROCK SIZE MAY BE ALLOWABLE FOR SMALLER TRAPS IF APPROVED BY LOCAL JURISDICTION. 6. THE TOP OF THE EARTHEN BERM SHALL BE A MINIMUM OF 6" HIGHER THAN THE TOP OF THE RIPRAP OUTLET STRUCTURE. 7. THE ENDS OF THE RIPRAP OUTLET STRUCTURE SHALL BE A MINIMUM OF 6" HIGHER THAN THE CENTER OF THE OUTLET STRUCTURE.

SEDIMENT TRAP MAINTENANCE NOTES

- 1. INSPECT BMPs EACH WORKDAY, AND MAINTAIN THEM IN EFFECTIVE OPERATING CONDITION. MAINTENANCE OF BMPs SHOULD BE PROACTIVE, NOT REACTIVE. INSPECT BMPs AS SOON AS POSSIBLE (AND ALWAYS WITHIN 24 HOURS) FOLLOWING A STORM THAT CAUSES SURFACE EROSION, AND PERFORM NECESSARY MAINTENANCE. 2. FREQUENT OBSERVATIONS AND MAINTENANCE ARE NECESSARY TO MAINTAIN BMPs IN EFFECTIVE OPERATING CONDITION. INSPECTIONS AND CORRECTIVE MEASURES SHOULD BE DOCUMENTED THOROUGHLY. 3. WHERE BMPs HAVE FAILED, REPAIR OR REPLACEMENT SHOULD BE INITIATED UPON DISCOVERY OF THE FAILURE. 4. REMOVE SEDIMENT ACCUMULATED IN TRAP AS NEEDED TO MAINTAIN THE FUNCTIONALITY OF THE BMP, TYPICALLY WHEN THE SEDIMENT DEPTH REACHES 1/2 THE HEIGHT OF THE RIPRAP OUTLET. 5. SEDIMENT TRAPS SHALL REMAIN IN PLACE UNTIL THE UPSTREAM DISTURBED AREA IS STABILIZED AND APPROVED BY THE LOCAL JURISDICTION. 6. WHEN SEDIMENT TRAPS ARE REMOVED, THE DISTURBED AREA SHALL BE COVERED WITH TOPSOIL, SEEDED AND MULCHED OR OTHERWISE STABILIZED IN A MANNER APPROVED BY THE LOCAL JURISDICTION.

(DETAILS ADAPTED FROM DOUGLAS COUNTY, COLORADO, NOT AVAILABLE IN AUTOCAD) NOTE: MANY JURISDICTIONS HAVE BMP DETAILS THAT VARY FROM UDFCD STANDARD DETAILS. CONSULT WITH LOCAL JURISDICTIONS AS TO WHICH DETAIL SHOULD BE USED WHEN DIFFERENCES ARE NOTED.

November 2010 Urban Drainage and Flood Control District Urban Storm Drainage Criteria Manual Volume 3 ST-3

SC-8 Sediment Trap (ST)

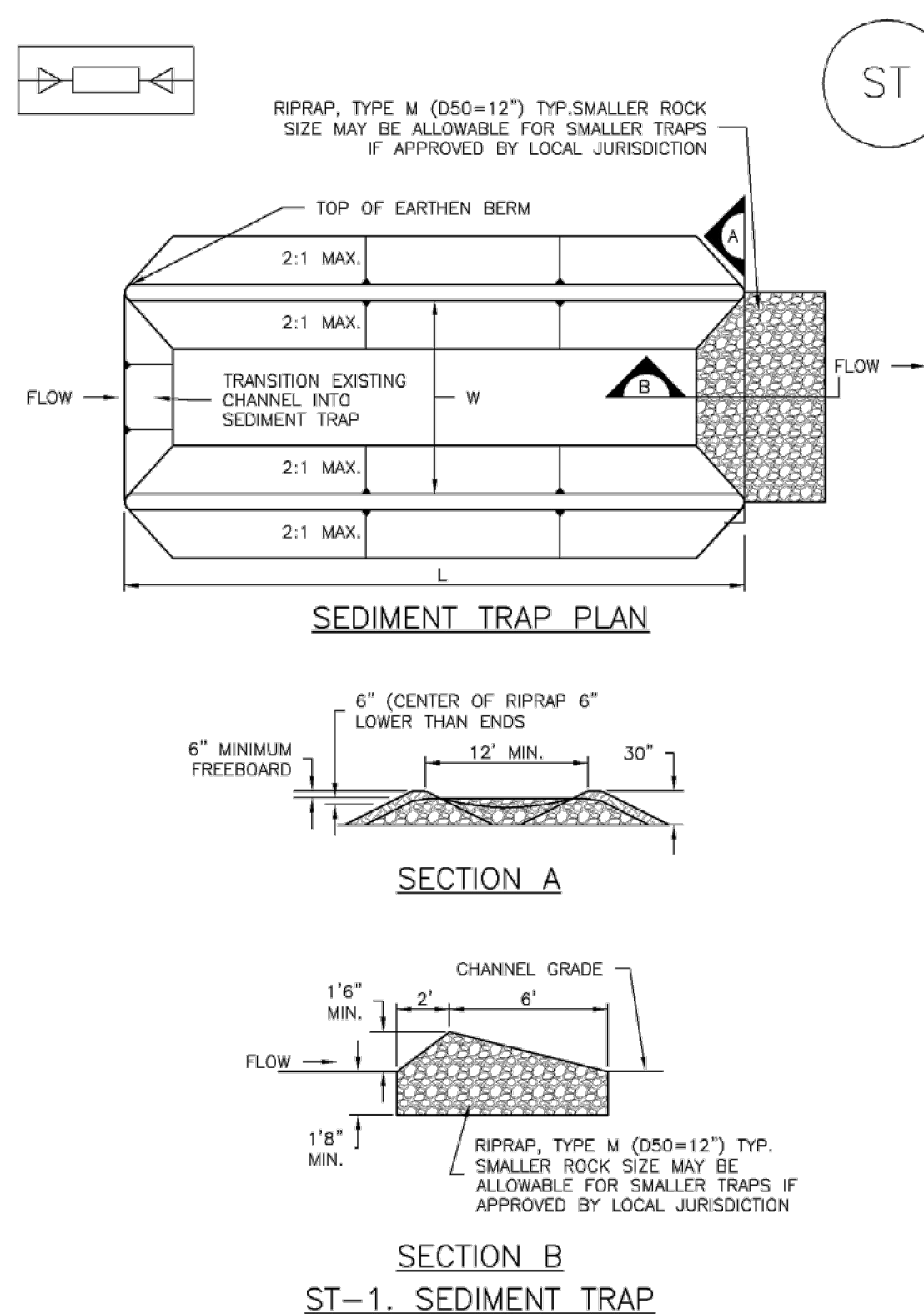

ST-2 Urban Drainage and Flood Control District Urban Storm Drainage Criteria Manual Volume 3 November 2010

EC-12

Check Dams (CD)

CHECK DAM INSTALLATION NOTES

- 1. SEE PLAN VIEW FOR: -LOCATION OF CHECK DAMS. -CHECK DAM TYPE (CHECK DAM OR REINFORCED CHECK DAM). -LENGTH (L), CREST LENGTH (CL), AND DEPTH (D). 2. CHECK DAMS INDICATED ON INITIAL SWMP SHALL BE INSTALLED AFTER CONSTRUCTION FENCE, BUT PRIOR TO ANY UPSTREAM LAND DISTURBING ACTIVITIES. 3. RIPRAP UTILIZED FOR CHECK DAMS SHOULD BE OF APPROPRIATE SIZE FOR THE APPLICATION. TYPICAL TYPES OF RIPRAP USED FOR CHECK DAMS ARE TYPE M (D50 12") OR TYPE L (D50 9"). 4. RIPRAP PAD SHALL BE TRENCHED INTO THE GROUND A MINIMUM OF 1'.

CHECK DAM MAINTENANCE NOTES

- 1. INSPECT BMPs EACH WORKDAY, AND MAINTAIN THEM IN EFFECTIVE OPERATING CONDITION. MAINTENANCE OF BMPs SHOULD BE PROACTIVE, NOT REACTIVE. INSPECT BMPs AS SOON AS POSSIBLE (AND ALWAYS WITHIN 24 HOURS) FOLLOWING A STORM THAT CAUSES SURFACE EROSION, AND PERFORM NECESSARY MAINTENANCE. 2. FREQUENT OBSERVATIONS AND MAINTENANCE ARE NECESSARY TO MAINTAIN BMPs IN EFFECTIVE OPERATING CONDITION. INSPECTIONS AND CORRECTIVE MEASURES SHOULD BE DOCUMENTED THOROUGHLY. 3. WHERE BMPs HAVE FAILED, REPAIR OR REPLACEMENT SHOULD BE INITIATED UPON DISCOVERY OF THE FAILURE. 4. SEDIMENT ACCUMULATED UPSTREAM OF THE CHECK DAMS SHALL BE REMOVED WHEN THE SEDIMENT DEPTH IS WITHIN 1/2 OF THE HEIGHT OF THE CREST. 5. CHECK DAMS ARE TO REMAIN IN PLACE UNTIL THE UPSTREAM DISTURBED AREA IS STABILIZED AND APPROVED BY THE LOCAL JURISDICTION. 6. WHEN CHECK DAMS ARE REMOVED, EXCAVATIONS SHALL BE FILLED WITH SUITABLE COMPACTED BACKFILL. DISTURBED AREA SHALL BE SEEDED AND MULCHED AND COVERED WITH GEOTEXTILE OR OTHERWISE STABILIZED IN A MANNER APPROVED BY THE LOCAL JURISDICTION.

(DETAILS ADAPTED FROM DOUGLAS COUNTY, COLORADO, NOT AVAILABLE IN AUTOCAD) NOTE: MANY JURISDICTIONS HAVE BMP DETAILS THAT VARY FROM UDFCD STANDARD DETAILS. CONSULT WITH LOCAL JURISDICTIONS AS TO WHICH DETAIL SHOULD BE USED WHEN DIFFERENCES ARE NOTED.

CD-4 Urban Drainage and Flood Control District Urban Storm Drainage Criteria Manual Volume 3 November 2010

EC-12 Check Dams (CD)

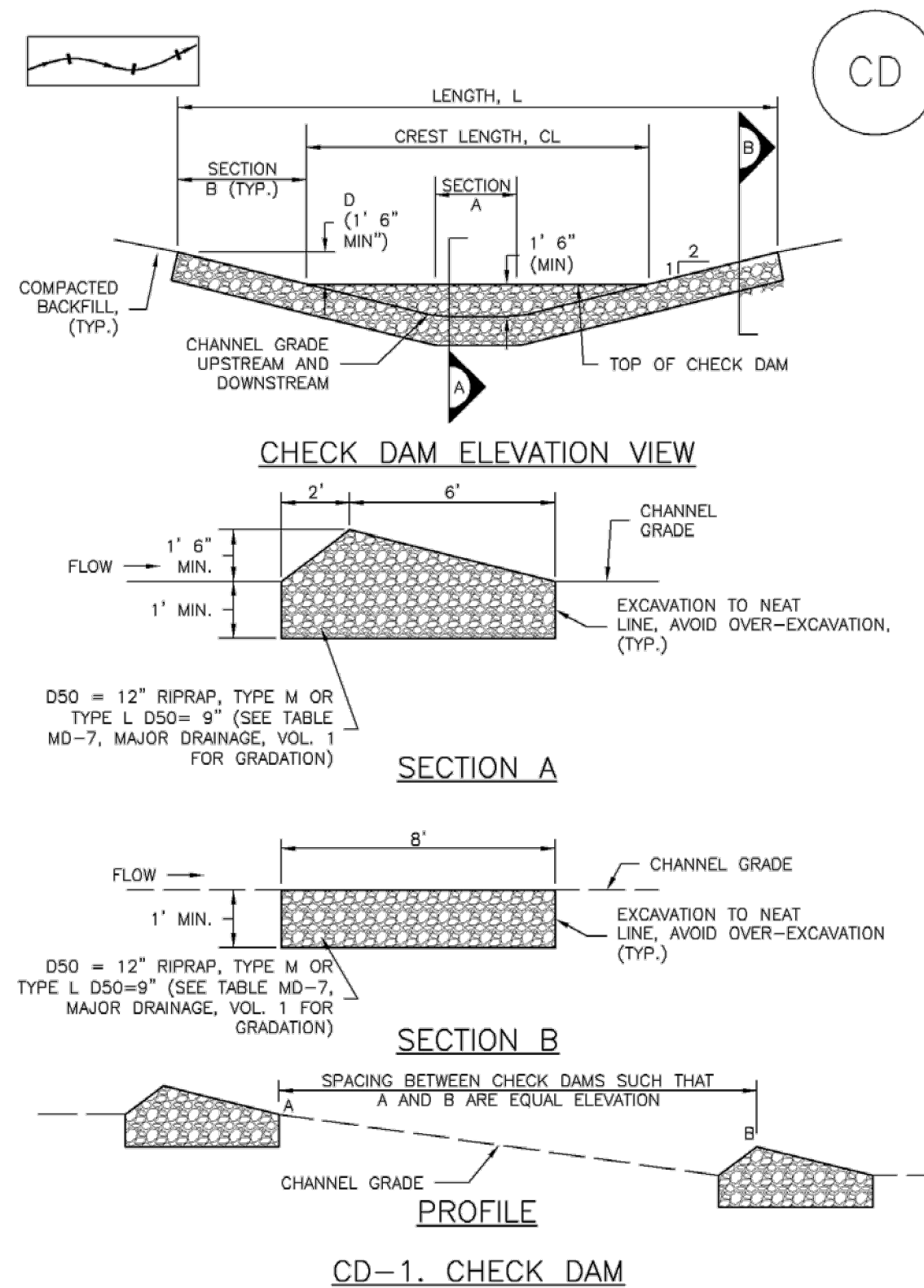

November 2010 Urban Drainage and Flood Control District Urban Storm Drainage Criteria Manual Volume 3 CD-3

SC-1

Silt Fence (SF)

SILT FENCE INSTALLATION NOTES

- 1. SILT FENCE MUST BE PLACED AWAY FROM THE TOE OF THE SLOPE TO ALLOW FOR WATER PONDING. SILT FENCE AT THE TOE OF A SLOPE SHOULD BE INSTALLED IN A FLAT LOCATION AT LEAST SEVERAL FEET (2-5 FT) FROM THE TOE OF THE SLOPE TO ALLOW ROOM FOR PONDING AND DEPOSITION. 2. A UNIFORM 6" X 4" ANCHOR TRENCH SHALL BE EXCAVATED USING TRENCHER OR SILT FENCE INSTALLATION DEVICE. NO ROAD GRADERS, BACKHOES, OR SIMILAR EQUIPMENT SHALL BE USED. 3. COMPACT ANCHOR TRENCH BY HAND WITH A "JUMPING JACK" OR BY WHEEL ROLLING. COMPACTION SHALL BE SUCH THAT SILT FENCE RESISTS BEING PULLED OUT OF ANCHOR TRENCH BY HAND. 4. SILT FENCE SHALL BE PULLED TIGHT AS IT IS ANCHORED TO THE STAKES. THERE SHOULD BE NO NOTICEABLE SAG BETWEEN STAKES AFTER IT HAS BEEN ANCHORED TO THE STAKES. 5. SILT FENCE FABRIC SHALL BE ANCHORED TO THE STAKES USING 1" HEAVY DUTY STAPLES OR NAILS WITH 1" HEADS. STAPLES AND NAILS SHOULD BE PLACED 3" ALONG THE FABRIC DOWN THE STAKE. 6. AT THE END OF A RUN OF SILT FENCE ALONG A CONTOUR, THE SILT FENCE SHOULD BE TURNED PERPENDICULAR TO THE CONTOUR TO CREATE A "J-HOOK". THE "J-HOOK" EXTENDING PERPENDICULAR TO THE CONTOUR SHOULD BE OF SUFFICIENT LENGTH TO KEEP RUNOFF FROM FLOWING AROUND THE END OF THE SILT FENCE (TYPICALLY 10' - 20'). 7. SILT FENCE SHALL BE INSTALLED PRIOR TO ANY LAND DISTURBING ACTIVITIES.

SILT FENCE MAINTENANCE NOTES

- 1. INSPECT BMPs EACH WORKDAY, AND MAINTAIN THEM IN EFFECTIVE OPERATING CONDITION. MAINTENANCE OF BMPs SHOULD BE PROACTIVE, NOT REACTIVE. INSPECT BMPs AS SOON AS POSSIBLE (AND ALWAYS WITHIN 24 HOURS) FOLLOWING A STORM THAT CAUSES SURFACE EROSION, AND PERFORM NECESSARY MAINTENANCE. 2. FREQUENT OBSERVATIONS AND MAINTENANCE ARE NECESSARY TO MAINTAIN BMPs IN EFFECTIVE OPERATING CONDITION. INSPECTIONS AND CORRECTIVE MEASURES SHOULD BE DOCUMENTED THOROUGHLY. 3. WHERE BMPs HAVE FAILED, REPAIR OR REPLACEMENT SHOULD BE INITIATED UPON DISCOVERY OF THE FAILURE. 4. SEDIMENT ACCUMULATED UPSTREAM OF THE SILT FENCE SHALL BE REMOVED AS NEEDED TO MAINTAIN THE FUNCTIONALITY OF THE BMP, TYPICALLY WHEN DEPTH OF ACCUMULATED SEDIMENTS IS APPROXIMATELY 6". 5. REPAIR OR REPLACE SILT FENCE WHEN THERE ARE SIGNS OF WEAR, SUCH AS SAGGING, TEARING, OR COLLAPSE. 6. SILT FENCE IS TO REMAIN IN PLACE UNTIL THE UPSTREAM DISTURBED AREA IS STABILIZED AND APPROVED BY THE LOCAL JURISDICTION, OR IS REPLACED BY AN EQUIVALENT PERIMETER SEDIMENT CONTROL BMP. 7. WHEN SILT FENCE IS REMOVED, ALL DISTURBED AREAS SHALL BE COVERED WITH TOPSOIL, SEEDED AND MULCHED OR OTHERWISE STABILIZED AS APPROVED BY LOCAL JURISDICTION.

(DETAIL ADAPTED FROM TOWN OF PARKER, COLORADO AND CITY OF AURORA, NOT AVAILABLE IN AUTOCAD) NOTE: MANY JURISDICTIONS HAVE BMP DETAILS THAT VARY FROM UDFCD STANDARD DETAILS. CONSULT WITH LOCAL JURISDICTIONS AS TO WHICH DETAIL SHOULD BE USED WHEN DIFFERENCES ARE NOTED.

SF-4 Urban Drainage and Flood Control District Urban Storm Drainage Criteria Manual Volume 3 November 2010

SC-1 Silt Fence (SF)

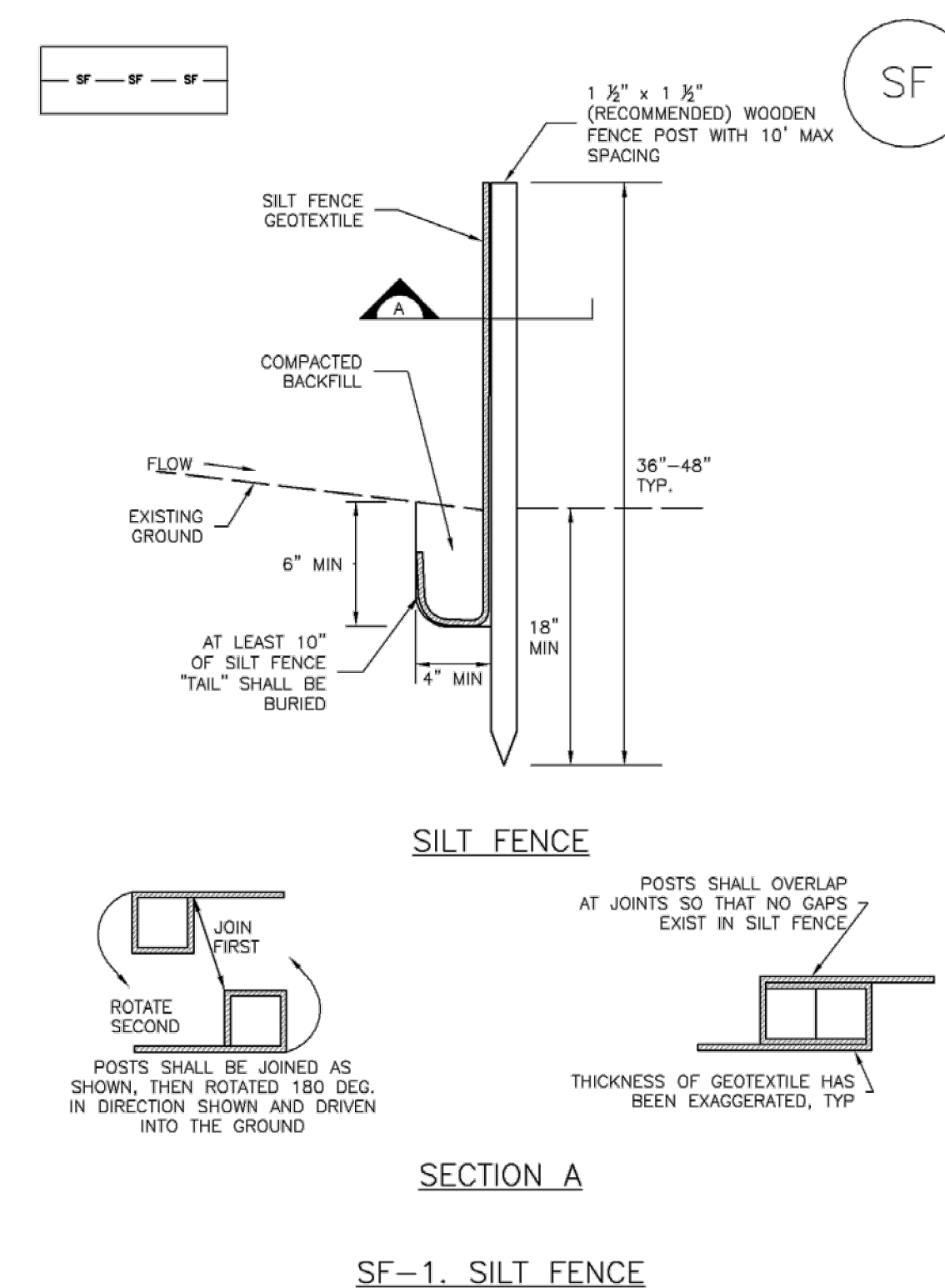

November 2010 Urban Drainage and Flood Control District Urban Storm Drainage Criteria Manual Volume 3 SF-3



COPYRIGHT THESE PLANS ARE AN INSTRUMENT OF SERVICE AND ARE THE PROPERTY OF GALLOWAY, AND MAY NOT BE DUPLICATED, DISCLOSED, OR REPRODUCED WITHOUT THE WRITTEN CONSENT OF GALLOWAY. COPYRIGHTS AND INFRINGEMENTS WILL BE ENFORCED AND PROSECUTED.



GRADING & EROSION CONTROL PLANS CONSTITUTION STORAGE JOHNSON DEVELOPMENT ASSOCIATES 2460 CANADA DRIVE COLORADO SPRINGS, CO 80915

Table with 4 columns: #, Date, Issue / Description, Init. It contains a series of empty rows for tracking changes.

Project No: JDA02 Drawn By: BLB Checked By: BAS Date: JULY 2023

GEC DETAILS

Construction Fence (CF)

SM-3

CONSTRUCTION FENCE MAINTENANCE NOTES

- 1. INSPECT BMPs EACH WORKDAY, AND MAINTAIN THEM IN EFFECTIVE OPERATING CONDITION. MAINTENANCE OF BMPs SHOULD BE PROACTIVE, NOT REACTIVE. INSPECT BMPs AS SOON AS POSSIBLE (AND ALWAYS WITHIN 24 HOURS) FOLLOWING A STORM THAT CAUSES SURFACE EROSION, AND PERFORM NECESSARY MAINTENANCE.
2. FREQUENT OBSERVATIONS AND MAINTENANCE ARE NECESSARY TO MAINTAIN BMPs IN EFFECTIVE OPERATING CONDITION. INSPECTIONS AND CORRECTIVE MEASURES SHOULD BE DOCUMENTED THOROUGHLY.
3. WHERE BMPs HAVE FAILED, REPAIR OR REPLACEMENT SHOULD BE INITIATED UPON DISCOVERY OF THE FAILURE.
4. CONSTRUCTION FENCE SHALL BE REPAIRED OR REPLACED WHEN THERE ARE SIGNS OF DAMAGE SUCH AS RIPS OR SAGS. CONSTRUCTION FENCE IS TO REMAIN IN PLACE UNTIL THE UPSTREAM DISTURBED AREA IS STABILIZED AND APPROVED BY THE LOCAL JURISDICTION.
5. WHEN CONSTRUCTION FENCES ARE REMOVED, ALL DISTURBED AREAS ASSOCIATED WITH THE INSTALLATION, MAINTENANCE, AND/OR REMOVAL OF THE FENCE SHALL BE COVERED WITH TOPSOIL, SEEDED AND MULCHED, OR OTHERWISE STABILIZED AS APPROVED BY LOCAL JURISDICTION.

NOTE: MANY JURISDICTIONS HAVE BMP DETAILS THAT VARY FROM UDFCD STANDARD DETAILS. CONSULT WITH LOCAL JURISDICTIONS AS TO WHICH DETAIL SHOULD BE USED WHEN DIFFERENCES ARE NOTED.

(DETAIL ADAPTED FROM TOWN OF PARKER, COLORADO, NOT AVAILABLE IN AUTOCAD)

November 2010 Urban Drainage and Flood Control District Urban Storm Drainage Criteria Manual Volume 3 CF-3

SM-3 Construction Fence (CF)

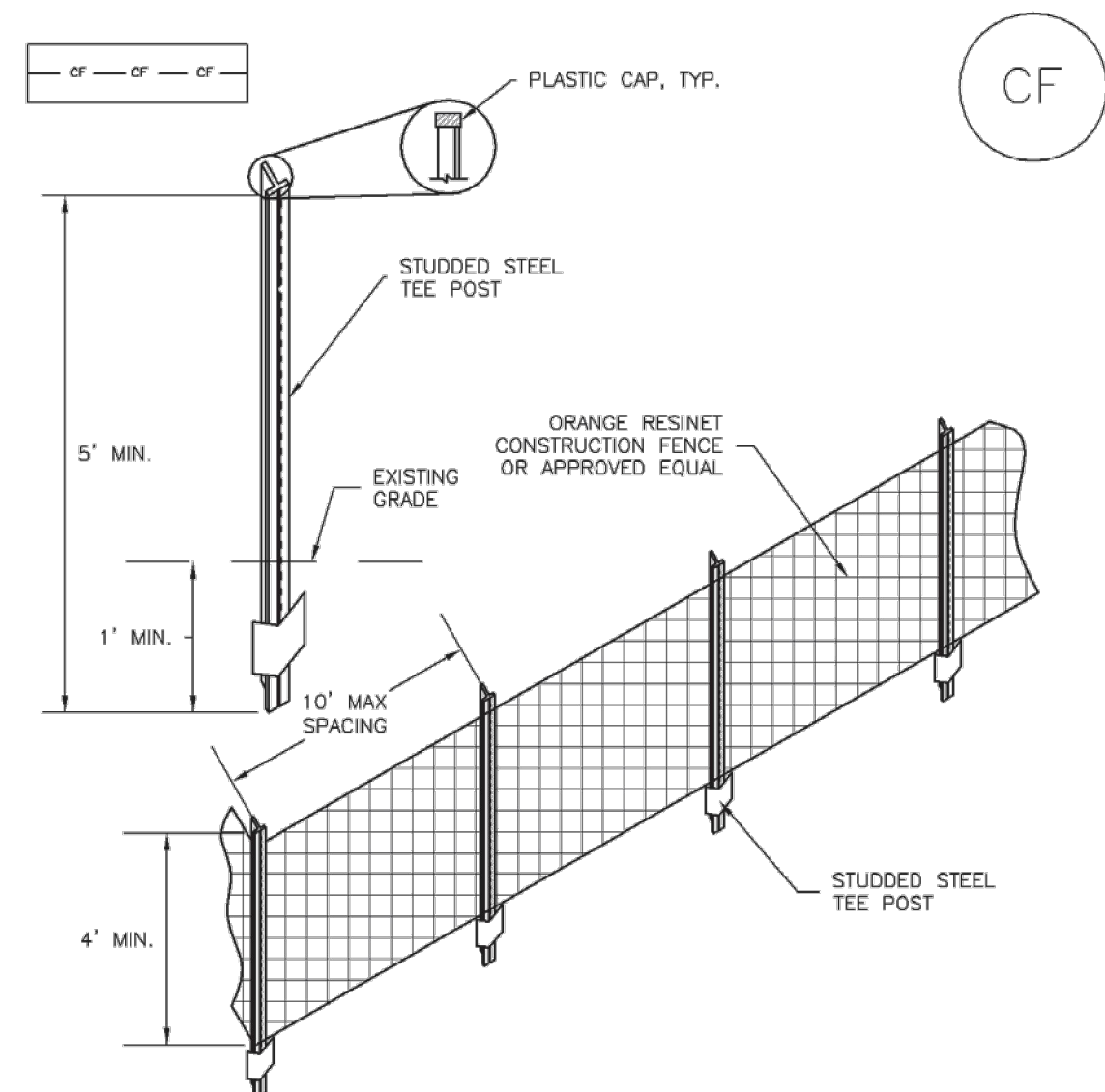

CF-1. PLASTIC MESH CONSTRUCTION FENCE

CONSTRUCTION FENCE INSTALLATION NOTES

- 1. SEE PLAN VIEW FOR: -LOCATION OF CONSTRUCTION FENCE.
2. CONSTRUCTION FENCE SHOWN SHALL BE INSTALLED PRIOR TO ANY LAND DISTURBING ACTIVITIES.
3. CONSTRUCTION FENCE SHALL BE COMPOSED OF ORANGE, CONTRACTOR-GRADE MATERIAL THAT IS AT LEAST 4' HIGH. METAL POSTS SHOULD HAVE A PLASTIC CAP FOR SAFETY.
4. STUDDED STEEL TEE POSTS SHALL BE UTILIZED TO SUPPORT THE CONSTRUCTION FENCE. MAXIMUM SPACING FOR STEEL TEE POSTS SHALL BE 10'.
5. CONSTRUCTION FENCE SHALL BE SECURELY FASTENED TO THE TOP, MIDDLE, AND BOTTOM OF EACH POST.

CF-2 Urban Drainage and Flood Control District Urban Storm Drainage Criteria Manual Volume 3 November 2010

Rock Sock (RS)

SC-5

ROCK SOCK MAINTENANCE NOTES

- 1. INSPECT BMPs EACH WORKDAY, AND MAINTAIN THEM IN EFFECTIVE OPERATING CONDITION. MAINTENANCE OF BMPs SHOULD BE PROACTIVE, NOT REACTIVE. INSPECT BMPs AS SOON AS POSSIBLE (AND ALWAYS WITHIN 24 HOURS) FOLLOWING A STORM THAT CAUSES SURFACE EROSION, AND PERFORM NECESSARY MAINTENANCE.
2. FREQUENT OBSERVATIONS AND MAINTENANCE ARE NECESSARY TO MAINTAIN BMPs IN EFFECTIVE OPERATING CONDITION. INSPECTIONS AND CORRECTIVE MEASURES SHOULD BE DOCUMENTED THOROUGHLY.
3. WHERE BMPs HAVE FAILED, REPAIR OR REPLACEMENT SHOULD BE INITIATED UPON DISCOVERY OF THE FAILURE.
4. ROCK SOCKS SHALL BE REPLACED IF THEY BECOME HEAVILY SOILED, OR DAMAGED BEYOND REPAIR.
5. SEDIMENT ACCUMULATED UPSTREAM OF ROCK SOCKS SHALL BE REMOVED AS NEEDED TO MAINTAIN FUNCTIONALITY OF THE BMP, TYPICALLY WHEN DEPTH OF ACCUMULATED SEDIMENTS IS APPROXIMATELY 1/2 OF THE HEIGHT OF THE ROCK SOCK.
6. ROCK SOCKS ARE TO REMAIN IN PLACE UNTIL THE UPSTREAM DISTURBED AREA IS STABILIZED AND APPROVED BY THE LOCAL JURISDICTION.
7. WHEN ROCK SOCKS ARE REMOVED, ALL DISTURBED AREAS SHALL BE COVERED WITH TOPSOIL, SEEDED AND MULCHED OR OTHERWISE STABILIZED AS APPROVED BY LOCAL JURISDICTION.

NOTE: MANY JURISDICTIONS HAVE BMP DETAILS THAT VARY FROM UDFCD STANDARD DETAILS. CONSULT WITH LOCAL JURISDICTIONS AS TO WHICH DETAIL SHOULD BE USED WHEN DIFFERENCES ARE NOTED.

NOTE: THE DETAILS INCLUDED WITH THIS FACT SHEET SHOW COMMONLY USED, CONVENTIONAL METHODS OF ROCK SOCK INSTALLATION IN THE DENVER METROPOLITAN AREA. THERE ARE MANY OTHER SIMILAR PROPRIETARY PRODUCTS ON THE MARKET. UDFCD NEITHER ENDORSES NOR DISCOURAGES USE OF PROPRIETARY PROTECTION PRODUCTS. HOWEVER, IN THE EVENT PROPRIETARY METHODS ARE USED, THE APPROPRIATE DETAIL FROM THE MANUFACTURER MUST BE INCLUDED IN THE SWMP AND THE BMP MUST BE INSTALLED AND MAINTAINED AS SHOWN IN THE MANUFACTURER'S DETAILS.

November 2010 Urban Drainage and Flood Control District Urban Storm Drainage Criteria Manual Volume 3 RS-3

SC-5 Rock Sock (RS)

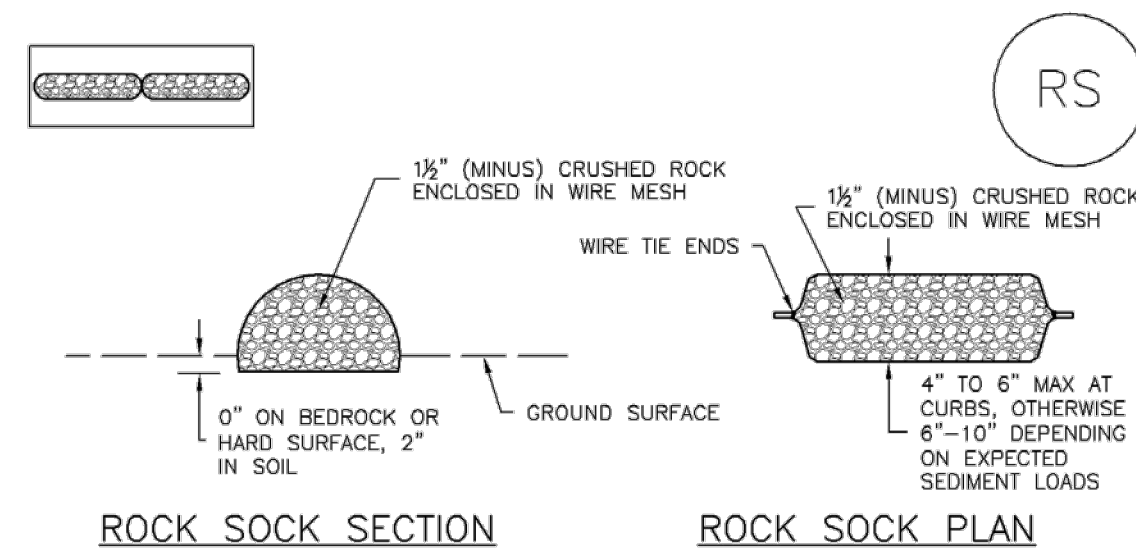

ROCK SOCK SECTION

ROCK SOCK PLAN

ANY GAP AT JOINT SHALL BE FILLED WITH AN ADEQUATE AMOUNT OF 1/2 (MINUS) CRUSHED ROCK AND WRAPPED WITH ADDITIONAL WIRE MESH SECURED TO ENDS OF ROCK REINFORCED SOCK. AS AN ALTERNATIVE TO FILLING JOINTS BETWEEN ADJOINING ROCK SOCKS WITH CRUSHED ROCK AND ADDITIONAL WIRE WRAPPING, ROCK SOCKS CAN BE OVERLAPPED (TYPICALLY 12-INCH OVERLAP) TO AVOID GAPS.

Table with 2 columns: Sieve Size and Mass Percent Passing. Includes a gradation table for No. 4 sieve.

ROCK SOCK JOINTING

ROCK SOCK INSTALLATION NOTES

- 1. SEE PLAN VIEW FOR: -LOCATION(S) OF ROCK SOCKS.
2. CRUSHED ROCK SHALL BE 1/2 (MINUS) IN SIZE WITH A FRACTURED FACE (ALL SIDES) AND SHALL COMPLY WITH GRADATION SHOWN ON THIS SHEET (1/2 MINUS).
3. WIRE MESH SHALL BE FABRICATED OF 10 GAUGE POULTRY MESH, OR EQUIVALENT, WITH A MAXIMUM OPENING OF 1/2", RECOMMENDED MINIMUM ROLL WIDTH OF 48".
4. WIRE MESH SHALL BE SECURED USING "HOG RINGS" OR WIRE TIES AT 6" CENTERS ALONG ALL JOINTS AND AT 2" CENTERS ON ENDS OF SOCKS.
5. SOME MUNICIPALITIES MAY ALLOW THE USE OF FILTER FABRIC AS AN ALTERNATIVE TO WIRE MESH FOR THE ROCK ENCLOSURE.

RS-1. ROCK SOCK PERIMETER CONTROL

RS-2 Urban Drainage and Flood Control District Urban Storm Drainage Criteria Manual Volume 3 November 2010

SM-6

Stabilized Staging Area (SSA)

STABILIZED STAGING AREA MAINTENANCE NOTES

- 5. STABILIZED STAGING AREA SHALL BE ENLARGED IF NECESSARY TO CONTAIN PARKING, STORAGE, AND UNLOADING/LOADING OPERATIONS.
6. THE STABILIZED STAGING AREA SHALL BE REMOVED AT THE END OF CONSTRUCTION THE GRANULAR MATERIAL SHALL BE REMOVED OR, IF APPROVED BY THE LOCAL JURISDICTION, USED ON SITE, AND THE AREA COVERED WITH TOPSOIL, SEEDED AND MULCHED OR OTHERWISE STABILIZED IN A MANNER APPROVED BY LOCAL JURISDICTION.
NOTE: MANY MUNICIPALITIES PROHIBIT THE USE OF RECYCLED CONCRETE AS GRANULAR MATERIAL FOR STABILIZED STAGING AREAS DUE TO DIFFICULTIES WITH RE-ESTABLISHMENT OF VEGETATION IN AREAS WHERE RECYCLED CONCRETE WAS PLACED.
NOTE: MANY JURISDICTIONS HAVE BMP DETAILS THAT VARY FROM UDFCD STANDARD DETAILS. CONSULT WITH LOCAL JURISDICTIONS AS TO WHICH DETAIL SHOULD BE USED WHEN DIFFERENCES ARE NOTED.

(DETAILS ADAPTED FROM DOUGLAS COUNTY, COLORADO, NOT AVAILABLE IN AUTOCAD)

SSA-4 Urban Drainage and Flood Control District Urban Storm Drainage Criteria Manual Volume 3 November 2010

Stabilized Staging Area (SSA) SM-6

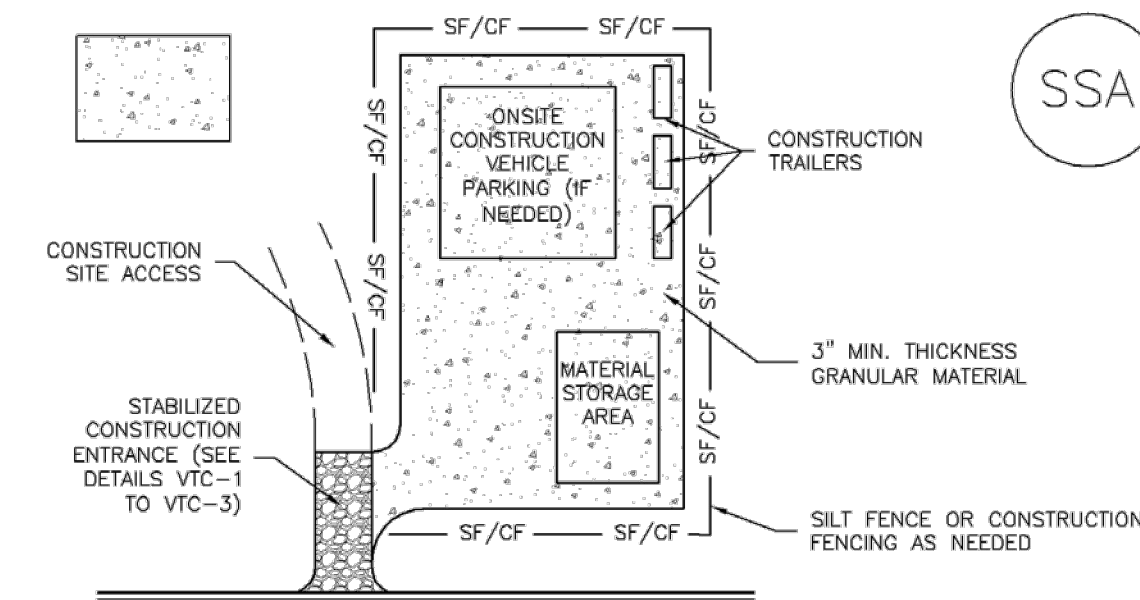

SSA-1. STABILIZED STAGING AREA

STABILIZED STAGING AREA INSTALLATION NOTES

- 1. SEE PLAN VIEW FOR: -LOCATION OF STAGING AREA(S). -CONTRACTOR MAY ADJUST LOCATION AND SIZE OF STAGING AREA WITH APPROVAL FROM THE LOCAL JURISDICTION.
2. STABILIZED STAGING AREA SHOULD BE APPROPRIATE FOR THE NEEDS OF THE SITE. OVERSIZING RESULTS IN A LARGER AREA TO STABILIZE FOLLOWING CONSTRUCTION.
3. STAGING AREA SHALL BE STABILIZED PRIOR TO OTHER OPERATIONS ON THE SITE.
4. THE STABILIZED STAGING AREA SHALL CONSIST OF A MINIMUM 3" THICK GRANULAR MATERIAL.
5. UNLESS OTHERWISE SPECIFIED BY LOCAL JURISDICTION, ROCK SHALL CONSIST OF DOT SECT. #703, AASHTO #3 COARSE AGGREGATE OR 6" (MINUS) ROCK.
6. ADDITIONAL PERIMETER BMPs MAY BE REQUIRED INCLUDING BUT NOT LIMITED TO SILT FENCE AND CONSTRUCTION FENCING.

STABILIZED STAGING AREA MAINTENANCE NOTES

- 1. INSPECT BMPs EACH WORKDAY, AND MAINTAIN THEM IN EFFECTIVE OPERATING CONDITION. MAINTENANCE OF BMPs SHOULD BE PROACTIVE, NOT REACTIVE. INSPECT BMPs AS SOON AS POSSIBLE (AND ALWAYS WITHIN 24 HOURS) FOLLOWING A STORM THAT CAUSES SURFACE EROSION, AND PERFORM NECESSARY MAINTENANCE.
2. FREQUENT OBSERVATIONS AND MAINTENANCE ARE NECESSARY TO MAINTAIN BMPs IN EFFECTIVE OPERATING CONDITION. INSPECTIONS AND CORRECTIVE MEASURES SHOULD BE DOCUMENTED THOROUGHLY.
3. WHERE BMPs HAVE FAILED, REPAIR OR REPLACEMENT SHOULD BE INITIATED UPON DISCOVERY OF THE FAILURE.
4. ROCK SHALL BE REAPPLIED OR REGRADED AS NECESSARY IF RUTTING OCCURS OR UNDERLYING SUBGRADE BECOMES EXPOSED.

November 2010 Urban Drainage and Flood Control District Urban Storm Drainage Criteria Manual Volume 3 SSA-3



COPYRIGHT THESE PLANS ARE AN INSTRUMENT OF SERVICE AND ARE THE PROPERTY OF GALLOWAY, AND MAY NOT BE DUPLICATED, DISCLOSED, OR REPRODUCED WITHOUT THE WRITTEN CONSENT OF GALLOWAY. COPYRIGHTS AND INFRINGEMENTS WILL BE ENFORCED AND PROSECUTED.

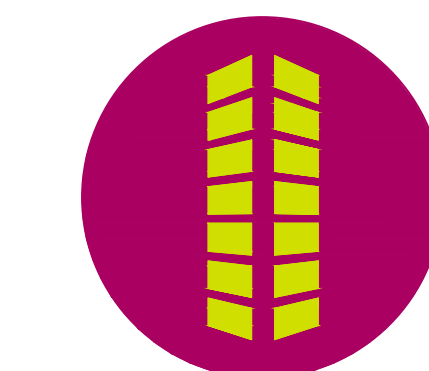

GRADING & EROSION CONTROL PLANS CONSTITUTION STORAGE JOHNSON DEVELOPMENT ASSOCIATES 2460 CANADA DRIVE COLORADO SPRINGS, CO 80915

Table with 4 columns: #, Date, Issue / Description, Init. Contains a checklist for revisions.

Project No: JDA02 Drawn By: BLB Checked By: BAS Date: JULY 2023

GEC DETAILS





## APPENDIX F

# EROSION AND STORMWATER QUALITY CONTROL PERMIT (ESQCP) EL PASO COUNTY APPLICATION AND PERMIT

EPC Project Number:

**APPLICANT INFORMATION**

**PERMIT NUMBER**

<b>Owner Information</b>	
Property Owner	
Applicant Name (Permit Holder)	
Company/Agency	
Position of Applicant	
Address (physical address, not PO Box)	
City	
State	
Zip Code	
Mailing address, if different from above	
Telephone	
FAX number	
Email Address	
Cellular Phone number	
<b>Contractor/Operator Information</b>	
Name (person of responsibility)	
Company	
Address (physical address, not PO Box)	
City	
State	
Zip Code	
Mailing address, if different from above	
Telephone	
FAX number	
Email Address	
Cellular Phone number	
Erosion Control Supervisor (ECS)*	
ECS Phone number*	
ECS Cellular Phone number*	

\*Required for all applicants. May be provided at later date pending securing a contract when applicable.

**PROJECT INFORMATION**

<b>Project Information</b>	
Project Name	
Legal Description	
Address (or nearest major cross streets)	
Acreage (total and disturbed)	Total:        acres Disturbed:        acres
Schedule	Start of Construction: Completion of Construction: Final Stabilization:
Project Purpose	
Description of Project	
Tax Schedule Number	

**FOR OFFICE USE ONLY**

The following signature from the ECM Administrator signifies the approval of this ESQCP. All work shall be performed in accordance with the permit, the El Paso County Engineering Criteria Manual (ECM) Standards, City of Colorado Springs Drainage Criteria Manual, Volume 2 (DCM2) as adopted by El Paso County Addendum, approved plans, and any attached conditions. The approved plans are an enforceable part of the ESQCP. Construction activity, except for the installation of initial construction BMPs, is not permitted until issuance of a Construction Permit and Notice to Proceed.

Signature of ECM Administrator: \_\_\_\_\_

Date \_\_\_\_\_



## **1.1 REQUIRED SUBMISSIONS**

In addition to this completed and signed application, the following items must be submitted to obtain an ESQCP:

- Permit fees;
- Stormwater Management Plan (SWMP) meeting the requirements of DCM2 and ECM either as part of the plan set or as a separate document;
- Operation and Maintenance Plan for any proposed permanent stormwater control measures; and
- Signed Private Detention Basin/Stormwater Quality Best Management Practice Maintenance Agreement and Easement, if any permanent stormwater control measures are to be constructed.

## **1.2 RESPONSIBILITY FOR DAMAGE**

The County and its officers and employees, including but not limited to the ECM Administrator, shall not be answerable or accountable in any manner for damage to property or for injury to or death of any person, including but not limited to a permit holder, persons employed by the permit holder, or persons acting in behalf of the permit holder, from any cause. The permit holder shall be responsible for any liability imposed by law and for damage to property or injuries to or death of any person, including but not limited to the permit holder, persons employed by the permit holder, persons acting in behalf of the permit holder, arising out of work or other activity permitted and done under a permit, or arising out of the failure to perform the obligations under any permit with respect to maintenance or any other obligations, or resulting from defects or obstructions, or from any cause whatsoever during the progress of the work or other activity, or at any subsequent time work or other activity is being performed under the obligations provided by and contemplated by the permit.

The permit holder shall indemnify, save, and hold harmless the County and its officers and employees, including but not limited to the BOCC and ECM Administrator, from all claims, suits or actions of every name, kind and description brought for or on account of damage to property or injuries to or death of any person, including but not limited to the permit holder, persons employed by the permit holder, persons acting in behalf of the permit holder and the public, resulting from the performance of work or other activity under the permit, or arising out of the failure to perform obligations under any permit with respect to maintenance or any other obligations, or resulting from defects or obstructions, or from any cause whatsoever during the progress of the work or other activity, or at any subsequent time work or other activity is being performed under the obligations provided by and contemplated by the permit, except as otherwise provided by state law. The permit holder waives any and all rights to any type of expressed or implied indemnity against the County, its officers or employees. It is the intent of the parties that the permit holder will indemnify, save, and hold harmless the County, its officers and employees from any and all claims, suits or actions as set forth above regardless of the existence or degree of fault of or negligence, whether active or passive, primary or secondary, on the part of the County, the permit holder, persons employed by the permit holder, or persons acting in behalf of the permit holder

**1.3 APPLICATION CERTIFICATION**

We, as the Applicants or the representative of the Applicants, hereby certify that this application is correct and complete as per the requirements presented in this application, the El Paso County Engineering Criteria Manual, and Drainage Criteria Manual, Volume 2 and El Paso County Addendum.

We, as the Applicants or the representatives of the Applicants, have read and will comply with all of the requirements of the specified Stormwater Management Plan and any other documents specifying stormwater best management practices to be used on the site, including permit conditions that may be required by the ECM Administrator. We understand that the stormwater control measures are to be maintained on the site and revised as necessary to protect stormwater quality as the project progresses. We further understand that a Construction Permit must be obtained and all necessary stormwater quality control measures are to be installed in accordance with the SWMP, the El Paso County Engineering Criteria Manual, Drainage Criteria Manual, Volume 2 and El Paso County Addendum before land disturbance begins and that failure to comply will result in a Stop Work Order and may result in other penalties as allowed by law. We further understand and agree to indemnify, save, and hold harmless the County and its officers and employees, including but not limited to the BOCC and ECM Administrator, from all claims, suits or actions of every name, kind and description as outlined in Section 1.2 Responsibility for Damage

**Brian Duncan** Digitally signed by Brian Duncan  
DN: C=US, E=bduncan@johnsondevelopment.net, O=Johnson  
Development Associates, Inc., CN=Brian Duncan  
Reason: I am approving this document  
Date: 2023.07.21 15:34:14-07'00'

Date: 7/21/2023

Signature of Owner or Representative

Brian Duncan

Print Name of Owner or Representative

\_\_\_\_\_  
Signature of Operator or Representative

Date: \_\_\_\_\_

\_\_\_\_\_  
Print Name of Operator or Representative

Permit Fee \$ \_\_\_\_\_

Surcharge \$ \_\_\_\_\_

Financial Surety \$ \_\_\_\_\_

Type of Surety \_\_\_\_\_

Total \$ \_\_\_\_\_