



FINAL DRAINAGE REPORT

CONSTITUTION STORAGE DEVELOPMENT

El Paso County, Colorado

PREPARED FOR:
Johnson Development Associates, Inc.
100 Dunbar Street, Suite 400
Spartanburg, SC 29306

PREPARED BY:
Galloway & Company, Inc.
1155 Kelly Johnson Blvd., Suite 305
Colorado Springs, CO 80920

DATE:
July 8, 2022

PCD Filing No.: PPR-2224

ENGINEER'S STATEMENT

The attached drainage plan and report were prepared under my direction and supervision and are correct to the best of my knowledge and belief. Said drainage report has been prepared according to the criteria established by the County for drainage reports and said report is in conformity with the applicable master plan of the drainage basin. I accept responsibility for any liability caused by any negligent acts, errors or omissions on my part in preparing this report.

Brady A. Shyrock, PE #38164
For and on behalf of Galloway & Company, Inc.

Date

DEVELOPER'S CERTIFICATION

I, The developer, have read and will comply with all of the requirements specified in this drainage report and plan.

By: _____

Date

Address: Johnson Development Associates, Inc.
101 N. Pacific Coast Hwy, Suite 308
El Segundo, CA 90245

EL PASO COUNTY CERTIFICATION

Filed in accordance with the requirements of the Drainage Criteria Manual, Volumes 1 and 2, El Paso County Engineering Criteria Manual and Land Development Code as amended.

Joshua Palmer, P.E.
Interim County Engineer

Date

Conditions:

TABLE OF CONTENTS

I.	Purpose	4
II.	General Description	4
III.	Drainage Criteria	4
IV.	Existing Drainage Conditions	5
V.	Four Step Process	6
	1. Employ Runoff Reduction Practices.....	6
	2. Stabilize Channels.....	6
	3. Provide Water Quality Capture Volume (WQCV)	6
	4. Consider Need for Industrial and Commercial BMPs	7
VI.	Proposed Drainage Conditions	7
VII.	Storm Sewer System.....	8
VIII.	Proposed Water Quality Detention Ponds	9
IX.	Proposed Channel Improvements.....	9
X.	Maintenance.....	9
XI.	Wetlands Mitigation	9
XII.	Floodplain Statement	10
XIII.	Drainage Fees & Maintenance.....	10
XIV.	Conclusion.....	10
XV.	References	10

Appendices:

- A. Exhibits and Figures
- B. Standard Design Charts & Tables
- C. Hydrologic Computations
- D. Hydraulic Computations
- E. Water Quality Computations
- F. Drainage Maps & Water Quality Plan

I. Purpose

The purpose of this Final Drainage Report is to identify on and offsite drainage patterns, locate and identify tributary or downstream drainage features and facilities that impact the site, and to identify which types of drainage facilities will be needed and where they will be located. This report will remain in general compliance with the approved FDR prepared by Costin Engineering Company, dated February 2, 1983.

II. General Description

The project is a self-storage commercial development located in the Cimarron Hills area of El Paso County, Colorado. The site is located in a portion of Section 05, Township 14 South, Range 65 West of the 6th Principal Meridian, County of El Paso, State of Colorado. The subject property is bounded by Constitution Avenue to the north, Canada Drive to the east, Peterson Road to the west, and existing Northcrest Filing No. 3 residential development to the south. A Vicinity Map is included in **Appendix A**.

This final drainage report is the basis for the drainage facility design in conformance with the previously approved FDR for the site prepared by Costin Engineering Company, "*Amendment Number 1, Final Drainage Study, Cimarron Northcrest Filing No. 3*", Costin Engineering Company, February 1983 (**FDR**). The site consists of approximately 3.716 acres and includes 929 storage units.

The existing soil types within the proposed site as determined by the NRCS Web Soil Survey for El Paso County Area consist of Truckton Sandy Loam (hydrologic soil group A). See the soils map included in **Appendix A**.

III. Drainage Criteria

Hydrology calculations were performed using the City of Colorado Springs/El Paso County Drainage Criteria Manual, as revised in November 1991 and October 1994 with County adopted Chapter 6 and Section 3.2.1 of Chapter 13 of the City of Colorado Springs/El Paso County Drainage Criteria Manual as revised in May 2014.

The drainage calculations were based on the criteria manual Figure 6-5 and IDF equations to determine the intensity and are listed in Table 1 below.

Table 1 - Precipitation Data

Return Period	One Hour Depth (in.)	Intensity (in/hr)
5-year	1.50	5.17
100-year	2.52	8.68

The rational method was used to calculate peak flows as the tributary areas are less than 100 acres. The rational method has been proven to be accurate for basins of this size and is based on the following formula:

$$Q = CIA$$

Where:

- Q = Peak Discharge (cfs)
- C = Runoff Coefficient
- I = Runoff intensity (inches/hour)
- A = Drainage area (acres)

The runoff coefficients are calculated based on land use, percent imperviousness, and design storm for each basin, as shown in the drainage criteria manual (Table 6-6). Composite percent impervious and C values were calculated using the residential, streets, roofs, and lawns coefficients found in Table 6-6 of the manual.

The 100-year event was used as the major storm event. The 5-year event was used as the minor event. The UD-Inlets v5.01 spreadsheet was utilized for the sizing of the proposed sump inlets.

The UD-Detention v4.04 spreadsheet was utilized for the design of the proposed on-site water quality ponds, Ponds A, B, C, D, E.

IV. Existing Drainage Conditions

The site lies within the existing Sand Creek drainage basin (see Reference Map). Based on this report, existing topography, and proposed future developments, no off-site basins will impact the site. Stormwater from this site generally drains to the southeast and southwest and will be routed to a single (1) private full spectrum detention facility designated as FSD-1 which has been sized to accommodate the developed flows from this site. The rational method was used to analyze the individual basins within the site because their size permits it.

The property presently discharges via sheet flow along the southern property line onto the adjacent Eight Line Inc. property and Alvarado property. Portions of the site along the eastern and western property lines also drain to the adjacent right-of-ways.

While the **FDR** shows a total of 26 basins that were analyzed as part of the overall Northcrest Filing No. 3 development, for the purposes of this report, only one (1) of the Basins within the FDR will be used for analysis. This Basin, C-4 (6.3 AC, $Q_5 = 7.0$ cfs, $Q_{100} = 18.30$ cfs) is located at the northwest corner of the approved FDR study area and drains through properties to the south to Allyn Way.

For a more in-depth analysis of existing tributary conditions as it pertains to this phase of development, an existing basin map has been prepared. The existing map can be found in **Appendix F** and basins are described below. The site has been divided into six (6) sub-basins to better show where runoff flows in the current conditions.

Basin EX-1 (0.05 AC, $Q_5 = 0.0$ cfs, $Q_{100} = 0.1$ cfs): This basin encompasses a portion of the southwest of the site in the existing condition. This basin consists of un-developed land. Runoff from this basin will sheet flow to the south before outfalling onto the adjacent Eight Line Inc. property. **(DP 1)**.

Basin EX-2 (0.26 AC, $Q_5 = 0.0$ cfs, $Q_{100} = 0.4$ cfs): This basin encompasses the southwest portion of the site in the existing condition. This basin consists of un-developed land. Runoff from this basin will sheet flow to the south before outfalling onto the adjacent Alvarado property. **(DP 2)**.

Basin EX-3 (0.39 AC, $Q_5 = 0.0$ cfs, $Q_{100} = 0.7$ cfs): This basin encompasses the western portion of the site in the existing condition, as well as a portion of the Peterson Road right-of-way. This basin consists of un-developed land and a portion of existing sidewalk. Runoff from this basin will sheet flow to the southwest before outfalling into Peterson Road. **(DP 3)**.

Basin EX-4 (0.03 AC, $Q_5 = 0.1$ cfs, $Q_{100} = 0.2$ cfs): This basin encompasses a portion of the northwest of the site in the existing condition. This basin consists mostly of existing sidewalk. Runoff from this basin will sheet flow to the north before outfalling into Constitution Avenue. **(DP 4)**.

Basin EX-5 (2.69 AC, $Q_5 = 0.4$ cfs, $Q_{100} = 4.8$ cfs): This basin encompasses the majority of the site in the existing condition, as well as a portion of Constitution Avenue right-of-way that is currently undeveloped. This basin consists of un-developed land, access drive, and a single-family home. Runoff from this basin will sheet flow to the south before outfalling onto the adjacent Eight Line Inc. property. **(DP 5)**.

Basin EX-6 (0.36 AC, $Q_5 = 0.0$ cfs, $Q_{100} = 0.5$ cfs): This basin encompasses the eastern portion of the site in the existing condition, as well as a portion of Constitution Avenue right-of-way that is currently undeveloped. This basin consists of un-developed land. Runoff from this basin will sheet flow to the southeast before outfalling into Canada Drive. **(DP 6)**.

V. Four Step Process

The Four Step Process is used to minimize the adverse impacts of urbanization and is a vital component of developing a balanced, sustainable project. Below identifies the approach to the four-step process:

1. Employ Runoff Reduction Practices

This step uses low impact development (LID) practices to reduce runoff at the source. Generally, rather than creating point discharges that are directly connected to impervious areas runoff is routed through pervious areas to promote infiltration. The Impervious Reduction Factor (IRF) method was used, and calculations can be found in **Appendix E**. For the majority of the site this is not practical, however portions of the site do drain through landscaped swales prior to entering the storm sewer system.

2. Stabilize Channels

This step implements stabilization to channels to accommodate developed flows while protecting infrastructure and controlling sediment loading from erosion in the drainageways. This project does not discharge to a channel. Flows are detained onsite to control release rates from the site down to existing rates and not adversely impact downstream facilities. The site is designed to release at or below the existing release rate for the site and will not negatively impact the downstream infrastructure.

3. Provide Water Quality Capture Volume (WQCV)

This step utilizes formalized water quality capture volume to slow the release of runoff from the site. The EURV volume will release in 72 hours, while the WQCV will release in no less than 12 hours because a sand filter is being utilized for water quality. An on-site water quality control volume detention pond will provide water quality treatment for all of the developed areas (utilizing a sand filter), prior to the runoff being released into existing curb flowlines at Canada Dr and Peterson Rd. Refer to WQCV Plan in **Appendix F**.

4. Consider Need for Industrial and Commercial BMPs

As this project is a commercial development, roof drains connecting directly to proposed water quality and detention facility, surface flows being routed to inlets that capture developed runoff and direct flows to proposed water quality and detention facility. Stockpile and concrete washout BMPs will be implemented onsite. At the Contractor's discretion, additional specialized BMPs which would be associated with an industrial or commercial site may be implemented.

VI. Proposed Drainage Conditions

Unresolved from review 1. Provide pond details in gec plan or provide a separate construction drawing set for the pond.

The proposed development lies completely within the Sand Creek (11) sub-basins. Site runoff will be collected via sheet flows, roof runoff, and one (1) proposed full spectrum detention pond (FSD-1). Within the pond, there will be a sand filter to infiltrate the water quality flows. All necessary calculations can be found within the appendices of this report.

According to the **FDR**, the proposed project site lies within Basin C-4 (6.3 AC, $Q_5 = 7.0$ cfs, $Q_{100} = 18.30$ cfs) is located at the northwest corner of the approved FDR study area. The property presently discharges via sheet flow along the southern property line onto the adjacent Eight Line Inc. property.

The site will provide one (1) Full Spectrum Sand Filter Basin (SFB). Ponds FSD-1 will discharge treated runoff at historic rates directly into the existing curb flowline at Canada Drive.

As has been mentioned previously, the site is proposed to have a land use of commercial self-storage. The site will consist of 929 storage units along with associated parking, drive aisles, RV storage, detention pond, and landscaping areas.

Basin PR-1 (0.24 AC, $Q_5 = 0.0$ cfs, $Q_{100} = 0.3$ cfs): Located at the southwestern corner of the site, Basin PR-1 contains the proposed landscaping improvements immediately adjacent to the existing residential development (Northcrest Filing No. 3). Runoff from this basin will sheet flow to the existing southern boundary into the Alvarado property as it does in the existing condition (Basin EX-2) (**DP 1**).

Basin PR-2A (0.11 AC, $Q_5 = 0.1$ cfs, $Q_{100} = 0.3$ cfs): Located on the western boundary of the site, this basin consists of driveway and landscaping. Runoff from this basin will sheet flow from the driveway to proposed curb and gutter at the driveway and Peterson Rd. Flows will then be routed, via curb & gutter downstream to the existing curb & gutter at the southwestern corner of the project site (**DP 2A**).

Basin PR-2B (0.01 AC, $Q_5 = 0.0$ cfs, $Q_{100} = 0.1$ cfs): Located on the northwestern corner of the site, this basin consists of sidewalk and landscaping. Runoff from this basin will sheet flow from the to existing curb and gutter at Peterson Rd. Flows will then be routed, via existing curb & gutter at the northwestern corner of the project site (**DP 2B**).

Basin PR-3 (0.22 AC, $Q_5 = 0.2$ cfs, $Q_{100} = 0.7$ cfs): Located on the northern boundary of the site, this basin consists of sidewalk and landscaping, as well as offsite areas within the Constitution right-of-way being developed. Runoff from this basin will sheet flow to existing curb and gutter in Constitution Ave. Flows will then be routed, via existing curb & gutter downstream to the northeastern corner of the project site (**DP 3**).

Basin PR-4 (0.24 AC, $Q_5 = 0.1$ cfs, $Q_{100} = 0.6$ cfs): Located on the eastern boundary of the site, this basin consists of driveway and landscaping. Runoff from this basin will sheet flow from the driveway to

proposed curb and gutter at the driveway and Canada Dr. Flows will then be routed, via curb & gutter downstream to the existing curb & gutter at the southeastern corner of the project site **(DP 4)**.

Basin PR-5 (1.32 AC, $Q_5 = 3.9$ cfs, $Q_{100} = 9.0$ cfs): Located on the northcentral portion of the site, this basin consists entirely of the proposed two-story building. Flows will be captured by roof drains and routed, via pipe **(DP 5)**, to the proposed (private) full spectrum detention (FSD-1) sand filter basin (SFB) located at the northeast corner of the site **(DP 10)**.

Basin PR-6 (0.83 AC, $Q_5 = 0.9$ cfs, $Q_{100} = 2.6$ cfs): Located on the central portion of the site, west and south of Basin PR-5. This basin consists of landscaping and driveway. Runoff from this basin will sheet flow from the driveway to the proposed curb and gutter to the proposed (private) 8' Colorado Springs D-10-R inlet **(DP 6A)** where flows will be routed, via pipe, to the proposed (private) full spectrum detention (FSD-1) sand filter basin (SFB) located at the northeast corner of the site **(DP 10)**. Emergency overflows will be routed downstream via proposed curb and gutter to Canada Drive.

Basin PR-7 (0.19 AC, $Q_5 = 0.6$ cfs, $Q_{100} = 1.3$ cfs): Located on the northcentral portion of the site east of Basin PR-5, this basin consists of landscaping, and RV storage. Runoff from this basin will sheet flow to the edge of the proposed RV storage area to a proposed (private) 18" Nyloplast Drain Basin inlet in sump condition **(DP 7)**, where flows will be routed, via pipe, to the proposed (private) full spectrum detention (FSD-1) sand filter basin (SFB) located at the northeast corner of the site **(DP 10)**. Emergency overflows will be routed downstream via proposed curb and gutter to Canada Drive.

Basin PR-8 (0.13 AC, $Q_5 = 0.0$ cfs, $Q_{100} = 0.2$ cfs): Located on the northern portion of the site, this basin consists entirely of landscaped area and swale north of the building. Runoff from this basin will sheet flow to the proposed swale to the proposed (private) CDOT Type C inlet **(DP 8)** where flows will be routed, via pipe, to the proposed (private) full spectrum detention (FSD-1) sand filter basin (SFB) located at the northeast corner of the site **(DP 10)**. Emergency overflows will be routed downstream via proposed curb and gutter to Canada Drive.

Basin PR-9 (0.18 AC, $Q_5 = 0.5$ cfs, $Q_{100} = 1.3$ cfs): Located in the eastern portion of the site, this basin consists of drive aisle and parking. Runoff from this basin will sheet flow to a proposed (private) 4' Colorado Springs D-10-R inlet in sump conditions, located on the south side of the eastern most parking stalls **(DP 9)** where flows will be routed, via pipe, to the proposed (private) full spectrum detention (FSD-1) sand filter basin (SFB) located at the northeast corner of the site **(DP 10)**. Emergency overflows will be routed downstream via proposed curb and gutter to Canada Drive.

Basin PR-10 (0.31 AC, $Q_5 = 0.0$ cfs, $Q_{100} = 0.6$ cfs): Located at the northeastern corner of the site, Basin PR-8 contains the entirety of the proposed (private) full spectrum detention (FSD-1) and adjacent landscaped area. Runoff from this basin will sheet flow directly to the (private) full spectrum detention (FSD-1) **(DP 10)**.

VII. Storm Sewer System

All development is anticipated to be urban and will include storm sewer & street inlets. Storm sewers collect storm water runoff and convey the water to the water quality facility prior to discharging. Storm sewer systems will be designed to the 100-year storm and checked with the 5-year storm. Inlets will be placed at sump areas and locations where street flow is larger than street capacity. UDFCD Inlet spreadsheet has been used to determine the size of all sump inlets.

There will be a proposed storm system within the site. The storm sewer system will discharge storm water into the proposed private full spectrum detention facility (FSD-1). The proposed system will consist of HDPE pipe, CDOT Type C inlets, Colorado Springs D-10-R inlets, Nyloplast Drain Basins, and storm sewer manholes.

Additionally, there are two (2) proposed drainage swales that run along the north and west side of the proposed building, respectively within sub-basins PR-8 and PR-6. The swales were analyzed using the Bentley software FlowMaster to properly size a triangular channel to convey the 100-year flows from the basins to FSD-1, while providing 1.0-ft of freeboard. The sizing calculations can be found in **Appendix D**.

Subsequent submittals will include details concerning at-grade inlet locations, street capacity, storm sewer sizing, outlet protection and location. Preliminary sump inlets have been sized and the calculations can be found in **Appendix D**.

VIII. Proposed Water Quality Detention Ponds

One (1) Water Quality Capture Volume Detention Pond (FSD-1) will be provided for the proposed site. The proposed pond will be privately owned and maintained by Johnson Development Associates Inc., once established. This detention pond is proposed to be full spectrum and will provide water quality and detention. Flows will be routed into the pond with the proposed (private) storm sewer system and release onto riprap pads into the pond. The WQCV release will be controlled by infiltration within the sand filter basin (SFB). The release rates for the WQCV and EURV will be 25-hours and 32-hours, respectively, and will pond to depths of 6499.37 and 6500.16. Flows exceeding the WQCV will be controlled by orifices and a modified Type C Outlet Structure and will be designed to release at or below the pre-development flow rate. A proposed outlet structure has been designed with this report. See **Appendix E** for calculations.

Basins PR-5 through PR-10 drain to FSD-1, totaling 2.96 acres and 80% of the project site. Per ECM Section I.7.1.C.1, 20% of the site may free release offsite, not to exceed 1 acre. Basins PR-1 through PR-4 free release, totaling 0.76 acres and 20% of the site area.

FSD-1: Located at the northeastern corner of the site, just west of existing Canada Dr. This pond will discharge to the existing western curb line within Canada Dr. The required volume WQCV and EURV are 0.057 Ac-Ft & 0.275 Ac-Ft, respectively. The total required detention basin volume is 0.424 Ac-Ft. See **Appendix E** for volume calculations.

IX. Proposed Channel Improvements

There are no proposed channel improvements as part of this report.

X. Maintenance

After completion of construction, the drainage facility (FSD-1) will be privately owned and maintained by Johnson Development Associates, Inc.

XI. Wetlands Mitigation

There are no existing wetlands within the project site.

XII. Floodplain Statement

No portion of the project sit lies with the designated Flood Zone as defined by the FIRM Map number 08041C0752G effective December 7, 2018. A copy of the FIRM Panel is included in **Appendix A**.

XIII. Drainage Fees & Maintenance

Drainage fees do not apply for Site Development Plans and are therefore not applicable to this project.

Below is a cost estimate for the improvements proposed with this filing.

Item	Quantity	Unit	Unit Cost	Cost
Storm Drain Improvements (Private)				
CDOT Type C Inlet (Private)	1	EA	\$ 5,138.00	\$ 5,138.00
Nyoplast Area Inlet -Single (Private)	1	EA	\$ 2,750.00	\$ 2,750.00
4' Type D-10 R Inlet (Private)	1	EA	\$ 6,138.00	\$ 6,138.00
8' Type D-10 R Inlet (Private)	1	EA	\$ 8,447.00	\$ 8,447.00
Storm Sewer Manhole, Slab Base	3	EA	\$ 7,082.00	\$ 21,246.00
18" Storm Drain - RCP (Private)	355	LF	\$ 70.00	\$ 24,850.00
18" Storm Drain - HDPE (Private)	475	LF	\$ 60.00	\$ 28,500.00
18" FES	1	EA	\$ 420.00	\$ 420.00
Subtotal				\$ 119,188.00
WQCV Detention Ponds (Private)				
Pond (FSD-1)	1	EA	\$ 45,000.00	\$ 45,000.00
Subtotal				\$ 45,000.00
Total				\$ 164,188.00
Contingency			10%	\$ 16,418.80
Grand Total				\$ 180,606.80

XIV. Conclusion

The Constitution Storage commercial development lies within the Sand Creek Drainage Basin. Water quality for the site is provided in a single on-site, private, Full Spectrum Detention Pond; FSD-1. All drainage facilities within this report were sized according to the El Paso County Drainage Criteria Manuals. The private full spectrum detention facility (FSD-1) will be maintained by Johnson Development Associates, Inc. The Constitution Storage development will not adversely impact any downstream facilities.

XV. References

1. *El Paso County Drainage Criteria Manual*, 1990.
2. *Drainage Criteria Manual, Volume 2*, City of Colorado Springs, 2002.
3. *El Paso County Drainage Criteria Manual Update*, 2015.
4. *El Paso County Engineering Criteria Manual*, 2020.

5. *Urban Storm Drainage Criteria Manual*, Urban Drainage and Flood Control District, January 2016 (with current revisions).
6. *Amendment Number 1, Final Drainage Study, Cimarron Northcrest Filing No. 3*", Costin Engineering Company, February 1983.

APPENDIX A

Exhibits and Figures

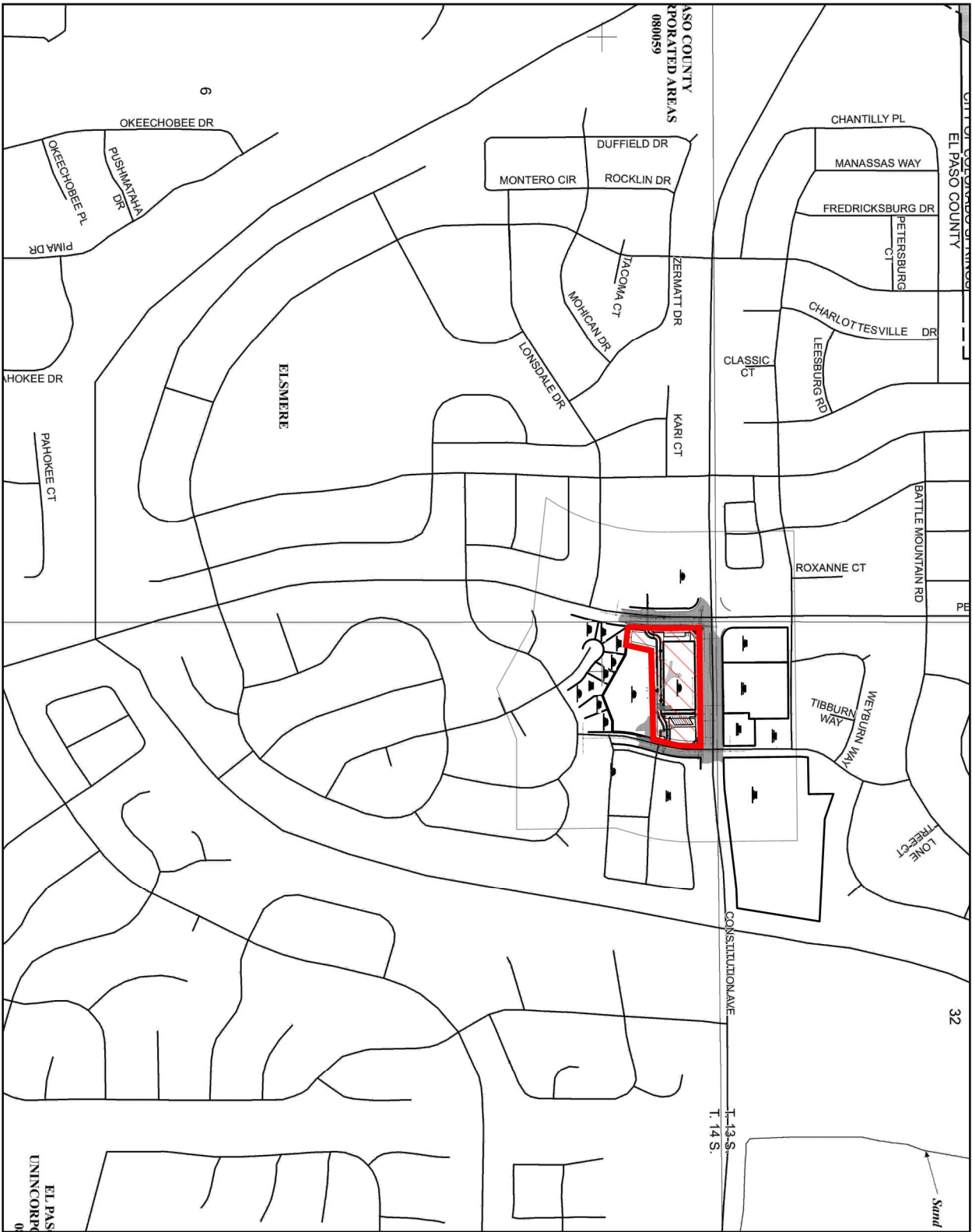

Sand

NATIONAL FLOOD INSURANCE PROGRAM



FIRM
FLOOD INSURANCE RATE MAP
EL PASO COUNTY,
COLORADO
AND INCORPORATED AREAS

PANEL 752 OF 1300
 (SEE MAP INDEX FOR FIRM PANEL LAYOUT)

COMMUNITY	NUMBER	PANEL	SUFFIX
CONCORD MOUNTAIN CITY OF	5000	752	0
EL PASO COUNTY	8000	752	0

Notes: This map was prepared on 03/15/2009 to update the previous National Flood Insurance Program map for El Paso County. The map was prepared by the Federal Emergency Management Agency.

MAP NUMBER
08041C0752G

MAP REVISED
DECEMBER 7, 2018

Federal Emergency Management Agency

NEIP

PANEL 0752G

MAP SCALE 1" = 500'

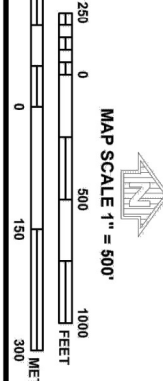

250 0 500 1000 FEET
 0 150 300 METERS

EL PASO UNINCORPORATED

This is an official FloodMap showing a portion of the above-referenced flood map created from the MFC FloodMap tool. This map does not reflect changes or amendments which may have been made to the map since the date of the MFC FloodMap tool. To ensure the map is current, please see the Flood Hazard Mapping Update Description Fact Sheet available on the FEMA Flood Map Service Center home page at <http://www.fema.gov>.

El Paso County Area, Colorado

97—Truckton sandy loam, 3 to 9 percent slopes

Map Unit Setting

National map unit symbol: 2x0j2

Elevation: 5,300 to 6,850 feet

Mean annual precipitation: 14 to 19 inches

Mean annual air temperature: 48 to 52 degrees F

Frost-free period: 85 to 155 days

Farmland classification: Not prime farmland

Map Unit Composition

Truckton and similar soils: 85 percent

Minor components: 15 percent

Estimates are based on observations, descriptions, and transects of the mapunit.

Description of Truckton

Setting

Landform: Interfluves, hillslopes

Landform position (two-dimensional): Backslope

Landform position (three-dimensional): Side slope

Down-slope shape: Linear

Across-slope shape: Linear

Parent material: Re-worked alluvium derived from arkose

Typical profile

A - 0 to 4 inches: sandy loam

Bt1 - 4 to 12 inches: sandy loam

Bt2 - 12 to 19 inches: sandy loam

C - 19 to 80 inches: sandy loam

Properties and qualities

Slope: 3 to 9 percent

Depth to restrictive feature: More than 80 inches

Drainage class: Well drained

Runoff class: Low

Capacity of the most limiting layer to transmit water (Ksat): High
(2.00 to 6.00 in/hr)

Depth to water table: More than 80 inches

Frequency of flooding: None

Frequency of ponding: None

Calcium carbonate, maximum content: 1 percent

Maximum salinity: Nonsaline (0.1 to 1.9 mmhos/cm)

Available water supply, 0 to 60 inches: Moderate (about 6.6 inches)

Interpretive groups

Land capability classification (irrigated): 6e

Land capability classification (nonirrigated): 6e

Hydrologic Soil Group: A
Ecological site: R049XB210CO - Sandy Foothill
Hydric soil rating: No

Minor Components

Blakeland

Percent of map unit: 8 percent
Landform: Interfluves, hillslopes
Landform position (two-dimensional): Summit, shoulder, backslope
Landform position (three-dimensional): Side slope, crest
Down-slope shape: Convex, linear
Across-slope shape: Convex, linear
Ecological site: R049XB210CO - Sandy Foothill
Hydric soil rating: No

Bresser

Percent of map unit: 7 percent
Landform: Interfluves, low hills
Landform position (two-dimensional): Footslope, toeslope
Landform position (three-dimensional): Base slope
Down-slope shape: Concave, linear
Across-slope shape: Concave, linear
Ecological site: R049XB210CO - Sandy Foothill
Hydric soil rating: No

Data Source Information

Soil Survey Area: El Paso County Area, Colorado
Survey Area Data: Version 19, Aug 31, 2021

Soil Map—El Paso County Area, Colorado

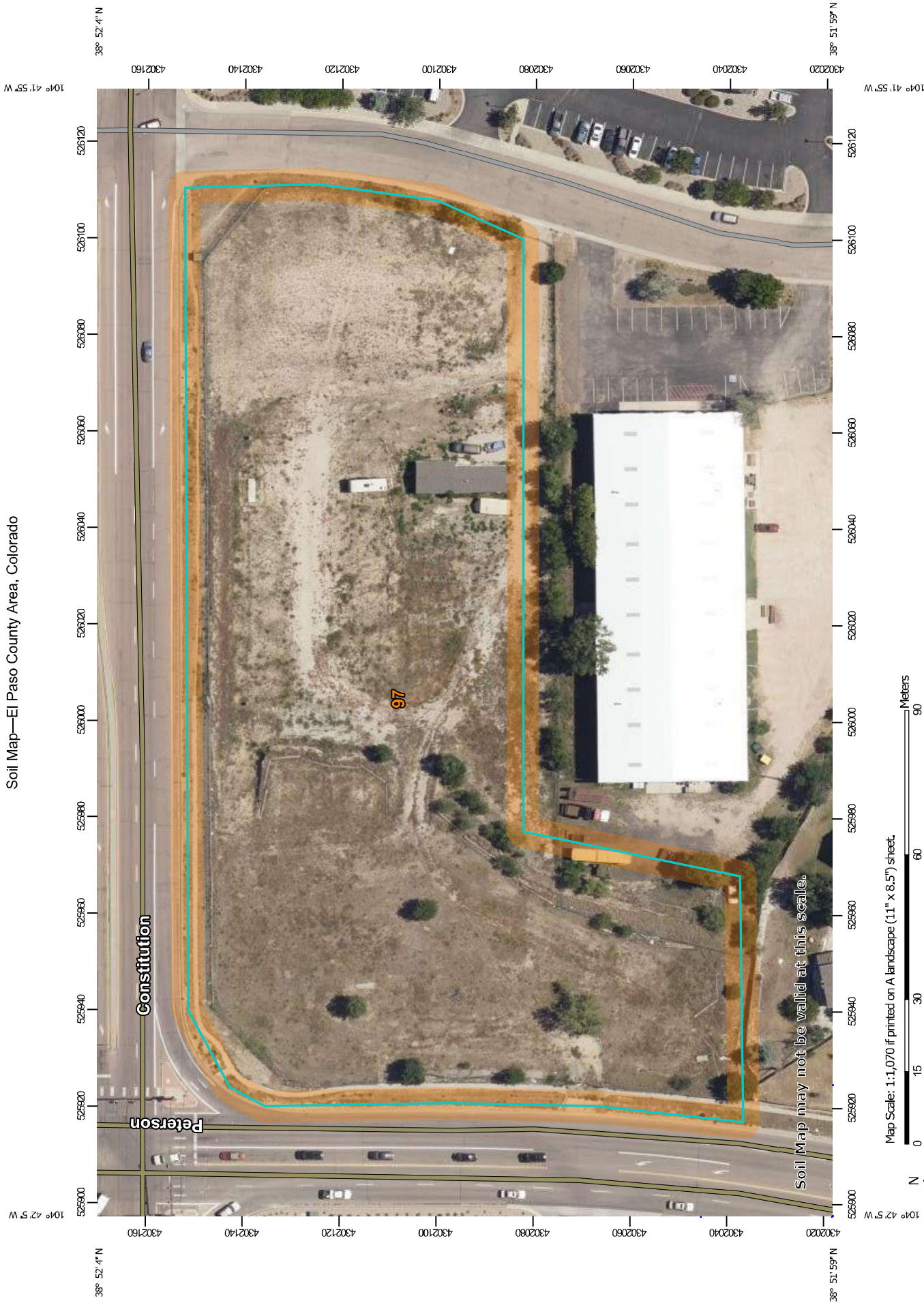

MAP LEGEND

- Area of Interest (AOI)
- Soils**
- Soil Map Unit Polygons
- Soil Map Unit Lines
- Soil Map Unit Points
- Special Point Features**
- Blowout
- Borrow Pit
- Clay Spot
- Closed Depression
- Gravel Pit
- Gravelly Spot
- Landfill
- Lava Flow
- Marsh or swamp
- Mine or Quarry
- Miscellaneous Water
- Perennial Water
- Rock Outcrop
- Saline Spot
- Sandy Spot
- Severely Eroded Spot
- Sinkhole
- Slide or Slip
- Sodic Spot
- Streams and Canals
- Transportation**
- Rails
- Interstate Highways
- US Routes
- Major Roads
- Local Roads
- Background**
- Aerial Photography

MAP INFORMATION

The soil surveys that comprise your AOI were mapped at 1:24,000.

Warning: Soil Map may not be valid at this scale.

Enlargement of maps beyond the scale of mapping can cause misunderstanding of the detail of mapping and accuracy of soil line placement. The maps do not show the small areas of contrasting soils that could have been shown at a more detailed scale.

Please rely on the bar scale on each map sheet for map measurements.

Source of Map: Natural Resources Conservation Service
 Web Soil Survey URL:
 Coordinate System: Web Mercator (EPSG:3857)

Maps from the Web Soil Survey are based on the Web Mercator projection, which preserves direction and shape but distorts distance and area. A projection that preserves area, such as the Albers equal-area conic projection, should be used if more accurate calculations of distance or area are required.

This product is generated from the USDA-NRCS certified data as of the version date(s) listed below.

Soil Survey Area: El Paso County Area, Colorado
 Survey Area Data: Version 19, Aug 31, 2021

Soil map units are labeled (as space allows) for map scales 1:50,000 or larger.

Date(s) aerial images were photographed: Aug 19, 2018—Sep 23, 2018

The orthophoto or other base map on which the soil lines were compiled and digitized probably differs from the background imagery displayed on these maps. As a result, some minor shifting of map unit boundaries may be evident.

Map Unit Legend

Map Unit Symbol	Map Unit Name	Acres in AOI	Percent of AOI
97	Truckton sandy loam, 3 to 9 percent slopes	3.8	100.0%
Totals for Area of Interest		3.8	100.0%

APPENDIX B

Standard Design Charts & Tables

Detailed descriptions of the curve number loss method and the dimensionless unit hydrograph can be found in these references:

- U.S. Department of Agriculture Natural Resources Conservation Service (NRCS) 1986. *Urban Hydrology for Small Watersheds*. Technical Release 55 (TR-55) (Second Edition). Prepared by Conservation Engineering Division.
- U.S. Army Corps of Engineers (USACE) 2010. *Hydrologic Modeling System HEC-HMS User's Manual*. Hydrologic Engineering Center, CPD-74A.

While it is possible to perform hydrograph analysis using the NRCS curve number loss method and dimensionless unit hydrograph using spreadsheet tools, it is cumbersome. More commonly, computer models such as the USACE HEC-HMS model are used. This section describes model input requirements for pre- and post-development modeling using HEC-HMS. Primary inputs include basin characteristics such as the drainage area, curve number and lag time. In addition, channel routing parameters are specified in HEC-HMS.

Other computer programs that use the NRCS loss method and dimensionless unit hydrograph may also be used, provided that the model results can be replicated using HEC-HMS. However, the curve number option for calculating rainfall losses in EPA SWMM is not acceptable because it is not an accurate implementation of the NRCS method and may produce results that vary significantly from HEC-HMS and TR-55.

4.1 NRCS Curve Numbers

NRCS curve numbers range from 0 to 100 (the recommended lower limit is 40) and can be used to calculate the volume of runoff from a storm event based on land use characteristics. A curve number of 0 would represent zero runoff (100% losses), and a curve number of 100 would represent zero losses (100% runoff).

The selection of a curve number value depends on the type of soil, identified by the NRCS hydrologic soil group (HSG), the land cover or treatment, and the antecedent runoff condition (ARC).

4.1.1 Hydrologic Soil Groups (HSG)

HSGs are determined by soil surveys published by the NRCS, which are generally done on a county-wide basis. The NRCS Soil Survey Geographic (SSURGO) Database is an online tool that may be used to characterize soils and HSGs.

The locations of each soil type for the drainage basin being studied must be identified by their HSG designation. The four hydrologic soil groups are defined by soil scientists, according to their runoff potential, as:

- **Group A:** Low runoff potential. Soils having low runoff potential and high infiltration rates even when thoroughly wetted. These consist chiefly of deep, well to excessively drained sand or gravel and have a high rate of water transmission (≥ 0.30 in/hr).
- **Group B:** Moderate runoff potential. Soils having moderate infiltration rates when thoroughly wetted and consist chiefly of moderately deep to deep, moderately well to well drained soils with moderately fine to moderately coarse textures. These soils have a moderate rate of water transmission (0.15-0.30 in/hr).

Assumed infiltration rate for sand filter.
 $0.30 \text{ in/hr} * 6985 \text{ sf} = 0.05 \text{ cfs infiltration}$

APPENDIX C

Hydrologic Computations

COMPOSITE % IMPERVIOUS CALCULATIONS

Existing Conditions

Subdivision: _____
Location: CO, Colorado Springs

Project Name: 6855 Constitution Ave Storage Site
Project No.: JDA000002
Calculated By: DDI
Checked By: BS
Date: 7/8/22

Basin ID	Total Area (ac)	Paved Roads			Lawns			Roofs			Basins Total Weighted % Imp.
		% Imp.	Area (ac)	Weighted % Imp.	% Imp.	Area (ac)	Weighted % Imp.	% Imp.	Area (ac)	Weighted % Imp.	
EX-1	0.05	100	0.00	0.0	2	0.05	2.0	90	0.00	0.00	2.0
EX-2	0.26	100	0.00	0.0	2	0.26	2.0	90	0.00	0.00	2.0
EX-3	0.39	100	0.02	4.2	2	0.38	1.9	90	0.00	0.00	6.1
EX-4	0.03	100	0.02	77.0	2	0.01	0.5	90	0.00	0.00	77.5
EX-5	2.69	100	0.16	6.0	2	2.50	1.9	90	0.03	1.00	8.9
EX-6	0.36	100	0.00	0.0	2	0.36	2.0	90	0.00	0.00	2.0



STANDARD FORM SF-2
TIME OF CONCENTRATION

Existing Conditions

Subdivision: _____
Location: CO, Colorado Springs

Project Name: 6855 Constitution Ave Storage Site
Project No.: JDA000002
Calculated By: DDJ
Checked By: BS
Date: 7/8/22

BASIN ID	D.A. (AC)	Hydrologic Soils Group	Impervious (%)	C ₁₀₀	C ₅	INITIAL/OVERLAND (T _i)			TRAVEL TIME (T _t)				T _c CHECK (URBANIZED BASINS)		FINAL T _c (MIN)		
						L (FT)	S (%)	T _i (MIN)	L (FT)	S (%)	Cv	VEL. (FPS)	T _t (MIN)	COMP. T _c (MIN)		TOTAL LENGTH (FT)	Urbanized T _c (MIN)
EX-1	0.05	A	2.0	0.22	0.00	61	27.0	5.2	0	1.5	20.0	2.4	0.0	5.2	61.0	10.3	5.2
EX-2	0.26	A	2.0	0.22	0.00	100	3.0	14.0	130	7.3	15.0	4.1	0.5	14.5	230.0	11.3	11.3
EX-3	0.39	A	6.1	0.25	0.03	210	3.0	19.7	0	1.5	20.0	2.4	0.0	19.7	210.0	11.2	11.2
EX-4	0.03	A	77.5	0.63	0.53	16.5	2.0	3.4	16	1.5	20.0	2.4	0.1	3.5	32.5	10.2	5.0
EX-5	2.69	A	8.9	0.27	0.05	300	2.0	26.4	0	1.5	20.0	2.4	0.0	26.4	300.0	11.7	11.7
EX-6	0.36	A	2.0	0.22	0.00	200	5.0	16.7	0	1.5	20.0	2.4	0.0	16.7	200.0	11.1	11.1

NOTES:

T_i = (0.395*(1.1 - C₅)*(L)^{0.5})/((S)^{0.33}), S in ft/ft

T_t = L/60V (Velocity From Fig. 501)

Velocity V = Cv*S^{0.5}, S in ft/ft

T_c Check = 10+L/180

For Urbanized basins a minimum T_c of 5.0 minutes is required.

For non-urbanized basins a minimum T_c of 10.0 minutes is required

COMPOSITE % IMPERVIOUS CALCULATIONS

Proposed Conditions

Subdivision: _____
Location: CO, Colorado Springs

Project Name: 6855 Constitution Ave Storage Site
Project No.: JDA000002
Calculated By: DDJ
Checked By: BS
Date: 7/8/22

Basin ID	Total Area (ac)	Paved Roads			Lawns			Roofs			Basins Total Weighted % Imp.
		% Imp.	Area (ac)	Weighted % Imp.	% Imp.	Area (ac)	Weighted % Imp.	% Imp.	Area (ac)	Weighted % Imp.	
PR-1	0.24	100	0.00	0.0	2	0.24	2.0	90	0.00	0.00	2.0
PR-2A	0.11	100	0.04	39.7	2	0.07	1.2	90	0.00	0.00	40.9
PR-2B	0.01	100	0.008	75.5	2	0.003	0.5	90	0.00	0.00	76.0
PR-3	0.22	100	0.07	30.8	2	0.15	1.4	90	0.00	0.00	32.2
PR-4	0.24	100	0.06	23.2	2	0.18	1.5	90	0.00	0.00	24.7
PR-5	1.32	100	0.00	0.0	2	0.00	0.0	90	1.32	90.00	90.0
PR-6	0.83	100	0.49	58.6	2	0.34	0.8	90	0.00	0.00	59.4
PR-7	0.19	100	0.17	91.7	2	0.02	0.2	90	0.00	0.00	91.9
PR-8	0.13	100	0.00	0.0	2	0.13	2.0	90	0.00	0.00	2.0
PR-9	0.18	100	0.17	90.9	2	0.02	0.2	90	0.00	0.00	91.1
PR-10	0.31	100	0.00	0.0	2	0.31	2.0	90	0.00	0.00	2.0

**STANDARD FORM SF-2
TIME OF CONCENTRATION**

Proposed Conditions

Subdivision: _____
Location: CO, Colorado Springs

Project Name: 6855 Constitution Ave Storage Site
Project No.: JDA000002
Calculated By: DDJ
Checked By: BS
Date: 7/8/22

BASIN ID	D.A. (AC)	Hydrologic Soils Group	Impervious (%)	C ₁₀₀	C _s	INITIAL/OVERLAND (T _i)			TRAVEL TIME (T _t)				T _c CHECK (URBANIZED BASINS)			FINAL T _c (MIN)	
						L (FT)	S (%)	T _i (MIN)	L (FT)	S (%)	Cv	VEL. (FPS)	T _t (MIN)	COMP. T _c (MIN)	TOTAL LENGTH (FT)		Urbanized T _c (MIN)
PR-1	0.24	A	2.0	0.22	0.00	137	10.0	10.9	0	3.0	20.0	3.5	0.0	10.9	137.0	10.8	10.8
PR-2A	0.11	A	40.9	0.41	0.25	42	2.0	8.0	54	2.0	20.0	2.8	0.3	8.3	96.0	10.5	8.3
PR-2B	0.01	A	76.0	0.62	0.51												5.0
PR-3	0.22	A	32.2	0.38	0.20												5.0
PR-4	0.24	A	24.7	0.35	0.16	93	6.0	9.1	0	3.0	20.0	3.5	0.0	9.1	93.0	10.5	9.1
PR-5	1.32	A	90.0	0.79	0.71												5.0
PR-6	0.83	A	59.4	0.49	0.36	57	2.0	8.1	370	0.5	20.0	1.4	4.4	12.5	427.0	12.4	12.4
PR-7	0.19	A	91.9	0.81	0.74	42	2.0	3.4	47	0.5	20.0	1.4	0.6	3.9	89.0	10.5	5.0
PR-8	0.13	A	2.0	0.22	0.00	25	2.0	8.0	390	2.5	20.0	3.2	2.1	10.0	415.0	12.3	10.0
PR-9	0.18	A	91.1	0.80	0.73	96	4.0	4.2	59	4.0	20.0	4.0	0.2	4.4	155.0	10.9	5.0
PR-10	0.31	A	2.0	0.22	0.00												5.0

NOTES:

T_i = (0.395*(1.1 - C_s)*(L^{0.5})/(S^{0.33}), S in ft/ft

T_t = L/60V (Velocity From Fig. 501)

Velocity V = Cv*S^{0.5}, S in ft/ft

T_c Check = 10+L/180

For Urbanized basins a minimum T_c of 5.0 minutes is required.

For non-urbanized basins a minimum T_c of 10.0 minutes is required

APPENDIX D

Hydraulic Computations

ALLOWABLE CAPACITY FOR ONE-HALF OF STREET (Minor & Major Storm)

(Based on Regulated Criteria for Maximum Allowable Flow Depth and Spread)

Project: 6855 Constitution Ave Self Storage
Inlet ID: INLET DP-6A

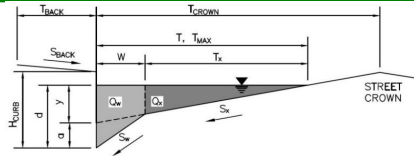

Gutter Geometry:

Maximum Allowable Width for Spread Behind Curb
 Side Slope Behind Curb (leave blank for no conveyance credit behind curb)
 Manning's Roughness Behind Curb (typically between 0.012 and 0.020)

T_{BACK} =	5.0	ft
S_{BACK} =	0.020	ft/ft
n_{BACK} =	0.013	

Height of Curb at Gutter Flow Line
 Distance from Curb Face to Street Crown
 Gutter Width
 Street Transverse Slope
 Gutter Cross Slope (typically 2 inches over 24 inches or 0.083 ft/ft)
 Street Longitudinal Slope - Enter 0 for sump condition
 Manning's Roughness for Street Section (typically between 0.012 and 0.020)

H_{CURB} =	6.00	inches
T_{CROWN} =	120.0	ft
W =	2.00	ft
S_x =	0.005	ft/ft
S_w =	0.083	ft/ft
S_o =	0.000	ft/ft
n_{STREET} =	0.016	

Max. Allowable Spread for Minor & Major Storm
 Max. Allowable Depth at Gutter Flowline for Minor & Major Storm
 Check boxes are not applicable in SUMP conditions

	Minor Storm	Major Storm	
T_{MAX} =	25.0	40.0	ft
d_{MAX} =	6.0	8.0	inches
	<input type="checkbox"/>	<input type="checkbox"/>	

Maximum Capacity for 1/2 Street based On Allowable Spread

Water Depth without Gutter Depression (Eq. ST-2)
 Vertical Depth between Gutter Lip and Gutter Flowline (usually 2")
 Gutter Depression ($d_c - (W * S_x * 12)$)
 Water Depth at Gutter Flowline
 Allowable Spread for Discharge outside the Gutter Section W ($T - W$)
 Gutter Flow to Design Flow Ratio by FHWA HEC-22 method (Eq. ST-7)
 Discharge outside the Gutter Section W , carried in Section T_x
 Discharge within the Gutter Section W ($Q_T - Q_x$)
 Discharge Behind the Curb (e.g., sidewalk, driveways, & lawns)
 Maximum Flow Based On Allowable Spread
 Flow Velocity within the Gutter Section
 $V*d$ Product: Flow Velocity times Gutter Flowline Depth

	Minor Storm	Major Storm	
y =	1.50	2.40	inches
d_c =	2.0	2.0	inches
a =	1.87	1.87	inches
d =	3.37	4.27	inches
T_x =	23.0	38.0	ft
E_o =	0.372	0.207	
Q_x =	0.0	0.0	cfs
Q_w =	0.0	0.0	cfs
Q_{BACK} =	0.0	0.0	cfs
Q_T =	SUMP	SUMP	cfs
V =	0.0	0.0	fps
$V*d$ =	0.0	0.0	

Maximum Capacity for 1/2 Street based on Allowable Depth

Theoretical Water Spread
 Theoretical Spread for Discharge outside the Gutter Section W ($T - W$)
 Gutter Flow to Design Flow Ratio by FHWA HEC-22 method (Eq. ST-7)
 Theoretical Discharge outside the Gutter Section W , carried in Section T_{xTH}
 Actual Discharge outside the Gutter Section W , (limited by distance T_{CROWN})
 Discharge within the Gutter Section W ($Q_d - Q_x$)
 Discharge Behind the Curb (e.g., sidewalk, driveways, & lawns)
 Total Discharge for Major & Minor Storm (Pre-Safety Factor)
 Average Flow Velocity Within the Gutter Section
 $V*d$ Product: Flow Velocity Times Gutter Flowline Depth
 Slope-Based Depth Safety Reduction Factor for Major & Minor ($d \geq 6$ ") Storm
 Max Flow Based on Allowable Depth (Safety Factor Applied)
 Resultant Flow Depth at Gutter Flowline (Safety Factor Applied)
 Resultant Flow Depth at Street Crown (Safety Factor Applied)

	Minor Storm	Major Storm	
T_{TH} =	68.8	102.1	ft
T_{xTH} =	66.8	100.1	ft
E_o =	0.104	0.065	
Q_{xTH} =	0.0	0.0	cfs
Q_x =	0.0	0.0	cfs
Q_w =	0.0	0.0	cfs
Q_{BACK} =	0.0	0.0	cfs
Q =	0.0	0.0	cfs
V =	0.0	0.0	fps
$V*d$ =	0.0	0.0	
R =	SUMP	SUMP	
Q_d =	SUMP	SUMP	cfs
d =			inches
d_{CROWN} =			inches

MINOR STORM Allowable Capacity is based on Depth Criterion
 MAJOR STORM Allowable Capacity is based on Depth Criterion

	Minor Storm	Major Storm	
Q_{allow} =	SUMP	SUMP	cfs

INLET IN A SUMP OR SAG LOCATION

MHFD-Inlet, Version 5.01 (April 2021)

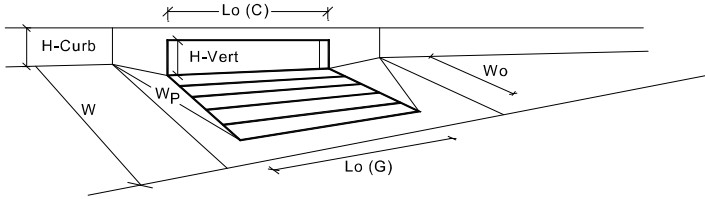

Design Information (Input)	MINOR	MAJOR	
Type of Inlet	Colorado Springs D-10-R		
Local Depression (additional to continuous gutter depression 'a' from above)	4.00	4.00	inches
Number of Unit Inlets (Grate or Curb Opening)	1	1	
Water Depth at Flowline (outside of local depression)	3.4	4.3	inches
Grate Information			
Length of a Unit Grate	N/A	N/A	feet
Width of a Unit Grate	N/A	N/A	feet
Area Opening Ratio for a Grate (typical values 0.15-0.90)	N/A	N/A	
Clogging Factor for a Single Grate (typical value 0.50 - 0.70)	N/A	N/A	
Grate Weir Coefficient (typical value 2.15 - 3.60)	N/A	N/A	
Grate Orifice Coefficient (typical value 0.60 - 0.80)	N/A	N/A	
Curb Opening Information			
Length of a Unit Curb Opening	8.00	8.00	feet
Height of Vertical Curb Opening in Inches	8.00	8.00	inches
Height of Curb Orifice Throat in Inches	8.00	8.00	inches
Angle of Throat (see USDCM Figure ST-5)	81.00	81.00	degrees
Side Width for Depression Pan (typically the gutter width of 2 feet)	2.00	2.00	feet
Clogging Factor for a Single Curb Opening (typical value 0.10)	0.10	0.10	
Curb Opening Weir Coefficient (typical value 2.3-3.7)	3.60	3.60	
Curb Opening Orifice Coefficient (typical value 0.60 - 0.70)	0.67	0.67	
Low Head Performance Reduction (Calculated)			
Depth for Grate Midwidth	N/A	N/A	ft
Depth for Curb Opening Weir Equation	0.12	0.19	ft
Combination Inlet Performance Reduction Factor for Long Inlets	0.34	0.43	
Curb Opening Performance Reduction Factor for Long Inlets	0.81	0.89	
Grated Inlet Performance Reduction Factor for Long Inlets	N/A	N/A	
Total Inlet Interception Capacity (assumes clogged condition)			
Inlet Capacity IS GOOD for Minor and Major Storms(>Q PEAK)	1.2	2.9	cfs
Q PEAK REQUIRED =	0.9	2.6	cfs

ALLOWABLE CAPACITY FOR ONE-HALF OF STREET (Minor & Major Storm)

(Based on Regulated Criteria for Maximum Allowable Flow Depth and Spread)

Project: 6855 Constitution Ave Self Storage
Inlet ID: INLET DP-9

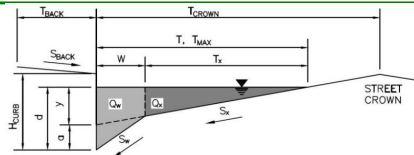

Gutter Geometry:

Maximum Allowable Width for Spread Behind Curb
 Side Slope Behind Curb (leave blank for no conveyance credit behind curb)
 Manning's Roughness Behind Curb (typically between 0.012 and 0.020)

T _{BACK} =	5.0	ft
S _{BACK} =	0.020	ft/ft
n _{BACK} =	0.013	

Height of Curb at Gutter Flow Line
 Distance from Curb Face to Street Crown
 Gutter Width
 Street Transverse Slope
 Gutter Cross Slope (typically 2 inches over 24 inches or 0.083 ft/ft)
 Street Longitudinal Slope - Enter 0 for sump condition
 Manning's Roughness for Street Section (typically between 0.012 and 0.020)

H _{CURB} =	6.00	inches
T _{CROWN} =	27.0	ft
W =	2.00	ft
S _X =	0.040	ft/ft
S _W =	0.083	ft/ft
S _O =	0.000	ft/ft
n _{STREET} =	0.016	

Max. Allowable Spread for Minor & Major Storm
 Max. Allowable Depth at Gutter Flowline for Minor & Major Storm
 Check boxes are not applicable in SUMP conditions

	Minor Storm	Major Storm	
T _{MAX} =	5.0	9.0	ft
d _{MAX} =	6.0	8.0	inches
	<input type="checkbox"/>	<input type="checkbox"/>	

Maximum Capacity for 1/2 Street based On Allowable Spread

Water Depth without Gutter Depression (Eq. ST-2)
 Vertical Depth between Gutter Lip and Gutter Flowline (usually 2")
 Gutter Depression ($d_c - (W * S_x * 12)$)
 Water Depth at Gutter Flowline
 Allowable Spread for Discharge outside the Gutter Section W (T - W)
 Gutter Flow to Design Flow Ratio by FHWA HEC-22 method (Eq. ST-7)
 Discharge outside the Gutter Section W, carried in Section T_X
 Discharge within the Gutter Section W (Q_T - Q_X)
 Discharge Behind the Curb (e.g., sidewalk, driveways, & lawns)
 Maximum Flow Based On Allowable Spread
 Flow Velocity within the Gutter Section
 V*d Product: Flow Velocity times Gutter Flowline Depth

	Minor Storm	Major Storm	
y =	2.40	4.32	inches
d _c =	2.0	2.0	inches
a =	1.03	1.03	inches
d =	3.43	5.35	inches
T _X =	3.0	7.0	ft
E _O =	0.815	0.542	
Q _X =	0.0	0.0	cfs
Q _W =	0.0	0.0	cfs
Q _{BACK} =	0.0	0.0	cfs
Q _T =	SUMP	SUMP	cfs
V =	0.0	0.0	fps
V*d =	0.0	0.0	

Maximum Capacity for 1/2 Street based on Allowable Depth

Theoretical Water Spread
 Theoretical Spread for Discharge outside the Gutter Section W (T - W)
 Gutter Flow to Design Flow Ratio by FHWA HEC-22 method (Eq. ST-7)
 Theoretical Discharge outside the Gutter Section W, carried in Section T_{X TH}
 Actual Discharge outside the Gutter Section W, (limited by distance T_{CROWN})
 Discharge within the Gutter Section W (Q_d - Q_X)
 Discharge Behind the Curb (e.g., sidewalk, driveways, & lawns)
 Total Discharge for Major & Minor Storm (Pre-Safety Factor)
 Average Flow Velocity Within the Gutter Section
 V*d Product: Flow Velocity Times Gutter Flowline Depth
 Slope-Based Depth Safety Reduction Factor for Major & Minor (d ≥ 6") Storm
 Max Flow Based on Allowable Depth (Safety Factor Applied)
 Resultant Flow Depth at Gutter Flowline (Safety Factor Applied)
 Resultant Flow Depth at Street Crown (Safety Factor Applied)

	Minor Storm	Major Storm	
T _{TH} =	10.4	14.5	ft
T _{X TH} =	8.4	12.5	ft
E _O =	0.482	0.356	
Q _{X TH} =	0.0	0.0	cfs
Q _X =	0.0	0.0	cfs
Q _W =	0.0	0.0	cfs
Q _{BACK} =	0.0	0.0	cfs
Q =	0.0	0.0	cfs
V =	0.0	0.0	fps
V*d =	0.0	0.0	
R =	SUMP	SUMP	
Q _d =	SUMP	SUMP	cfs
d =			inches
d _{CROWN} =			inches

MINOR STORM Allowable Capacity is based on Depth Criterion
 MAJOR STORM Allowable Capacity is based on Depth Criterion

	Minor Storm	Major Storm	
Q _{allow} =	SUMP	SUMP	cfs

INLET IN A SUMP OR SAG LOCATION

MHFD-Inlet, Version 5.01 (April 2021)

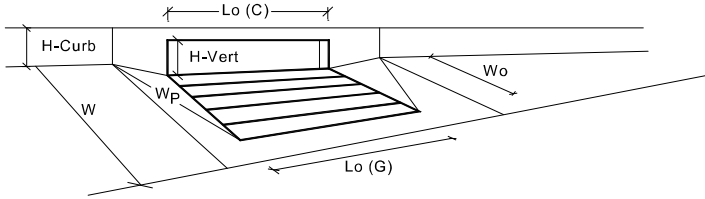

Design Information (Input)	MINOR	MAJOR	
Type of Inlet	Colorado Springs D-10-R		
Local Depression (additional to continuous gutter depression 'a' from above)	4.00	4.00	inches
Number of Unit Inlets (Grate or Curb Opening)	1	1	
Water Depth at Flowline (outside of local depression)	3.4	5.4	inches
Grate Information			
Length of a Unit Grate	N/A	N/A	feet
Width of a Unit Grate	N/A	N/A	feet
Area Opening Ratio for a Grate (typical values 0.15-0.90)	N/A	N/A	
Clogging Factor for a Single Grate (typical value 0.50 - 0.70)	N/A	N/A	
Grate Weir Coefficient (typical value 2.15 - 3.60)	N/A	N/A	
Grate Orifice Coefficient (typical value 0.60 - 0.80)	N/A	N/A	
Curb Opening Information			
Length of a Unit Curb Opening	4.00	4.00	feet
Height of Vertical Curb Opening in Inches	8.00	8.00	inches
Height of Curb Orifice Throat in Inches	8.00	8.00	inches
Angle of Throat (see USDCM Figure ST-5)	81.00	81.00	degrees
Side Width for Depression Pan (typically the gutter width of 2 feet)	2.00	2.00	feet
Clogging Factor for a Single Curb Opening (typical value 0.10)	0.10	0.10	
Curb Opening Weir Coefficient (typical value 2.3-3.7)	3.60	3.60	
Curb Opening Orifice Coefficient (typical value 0.60 - 0.70)	0.67	0.67	
Low Head Performance Reduction (Calculated)			
Depth for Grate Midwidth	N/A	N/A	ft
Depth for Curb Opening Weir Equation	0.12	0.28	ft
Combination Inlet Performance Reduction Factor for Long Inlets	0.48	0.75	
Curb Opening Performance Reduction Factor for Long Inlets	1.00	1.00	
Grated Inlet Performance Reduction Factor for Long Inlets	N/A	N/A	
Total Inlet Interception Capacity (assumes clogged condition)			
Inlet Capacity IS GOOD for Minor and Major Storms(>Q PEAK)	1.0	3.5	cfs
Q _{PEAK REQUIRED}	0.5	1.3	cfs

Figure 8-10. Inlet Capacity Chart Sump Conditions, Area (Type C) Inlet

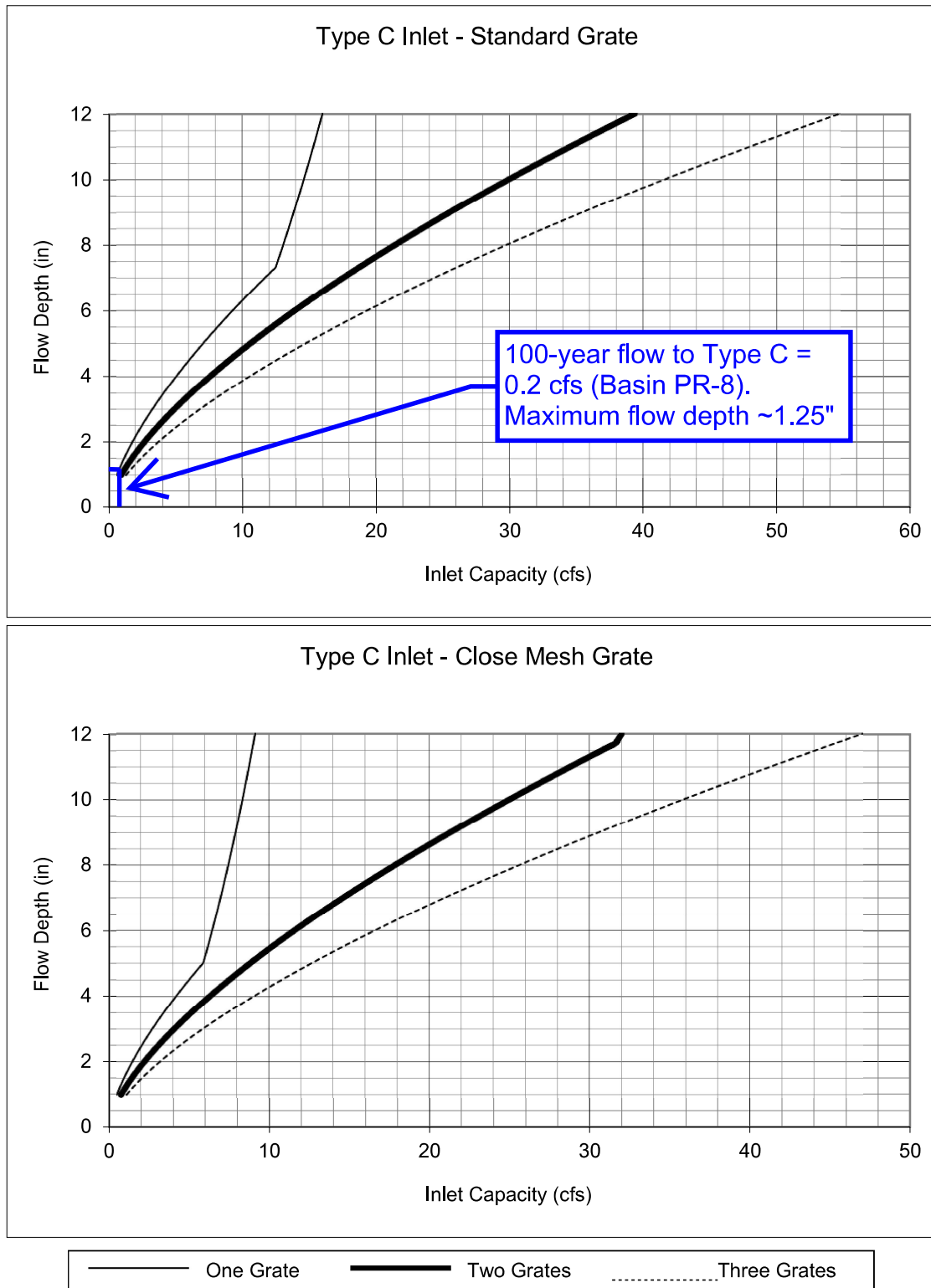

Notes:

1. The standard inlet parameters must apply to use these charts.



Nyloplast Inlet Capacity Table

DISCLAIMER: SAFETY FACTORS ARE NOT INCLUDED IN THESE CALCULATIONS. ACTUAL CALCULATIONS SHOULD BE CARRIED OUT AND VERIFIED BY THE DESIGN ENGINEER TAKING INTO ACCOUNT ALL LOCAL CONDITIONS. NYLOPLAST RECOMMENDS USING A MINIMUM SAFETY FACTOR OF 1.25 FOR PAVED AREAS AND 2.0 FOR TURF AREAS. ADS/NYLOPLAST IS NOT RESPONSIBLE FOR MISUSE OF THIS TOOL.

Input	
Type of Grate	18" Standard
Head (ft)	0.45
Properties	
Orifice Flow Area (in)	116.72
Orifice Flow Area (ft)	0.81
Weir Flow Perimeter (in)	52.04
Weir Flow Perimeter (ft)	4.34
Solution	
Capacity (cfs)	2.60
Capacity (gpm)	1167.00

maximum ponding depth ~4.5"

Basin PR-7:
100-year flow =
1.3 cfs (doubled
to account for
50% clogging)

$$Q_{weir} = CLH^{3/2}$$

$C = 3.33$ Weir Discharge Coefficient

$L =$ Perimeter of Grate Opening (ft)

$H =$ Flow Height of Water Surface Above Weir (ft)

$$Q_{orifice} = CA\sqrt{2gh}$$

$C = 0.60$ Orifice Discharge Coefficient

$A =$ Area of the Orifice (ft²)

$g =$ Gravitational Constant (32.2 $\frac{ft}{s^2}$)

$H =$ Depth of Water Above Center of Orifice (ft)

NYLOPLAST 18" DRAIN BASIN: 2818AG __ X

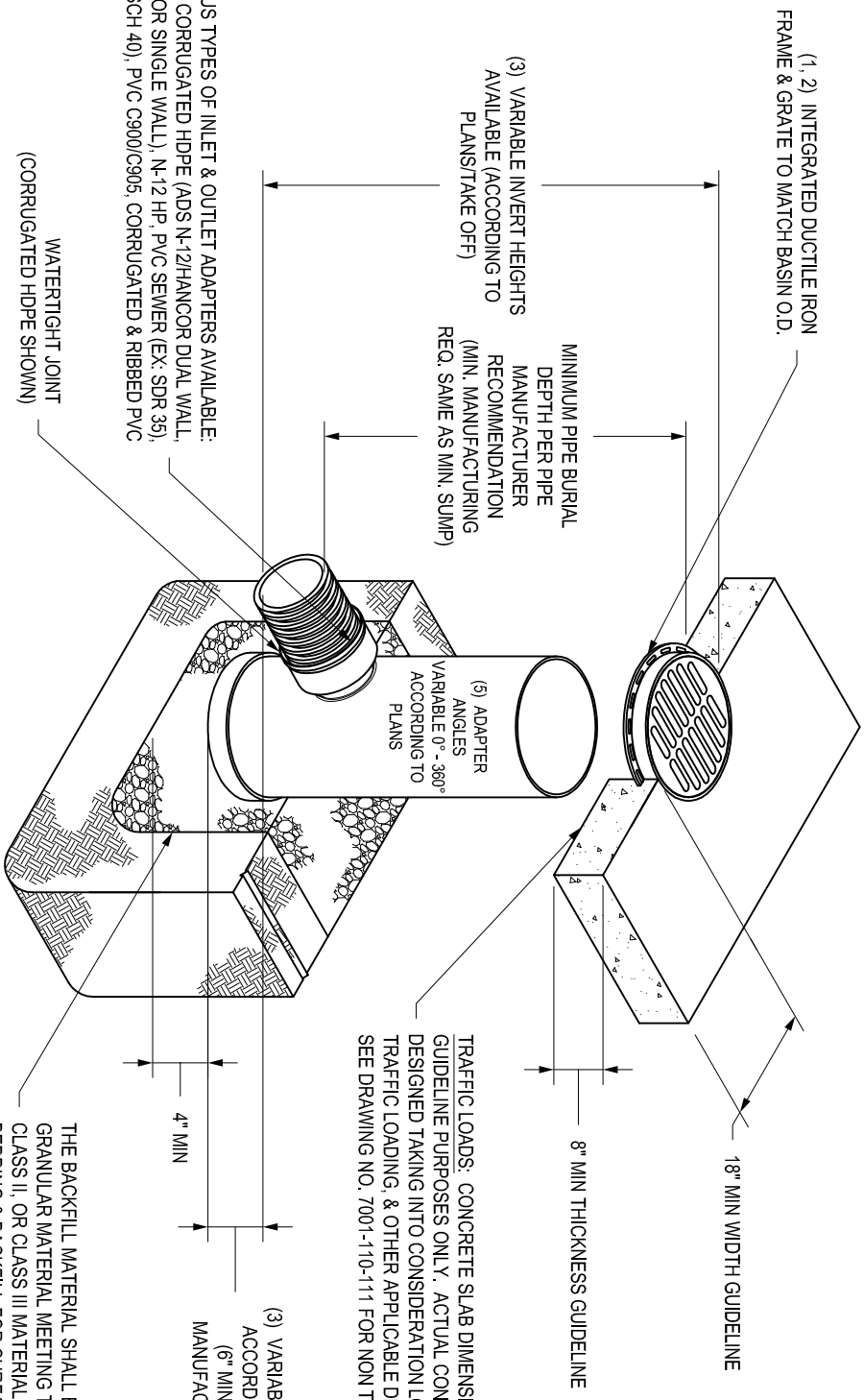

TRAFFIC LOADS: CONCRETE SLAB DIMENSIONS ARE FOR GUIDELINE PURPOSES ONLY. ACTUAL CONCRETE SLAB MUST BE DESIGNED TAKING INTO CONSIDERATION LOCAL SOIL CONDITIONS, TRAFFIC LOADING, & OTHER APPLICABLE DESIGN FACTORS. SEE DRAWING NO. 7001-110-111 FOR NON TRAFFIC INSTALLATION.

THE BACKFILL MATERIAL SHALL BE CRUSHED STONE OR OTHER GRANULAR MATERIAL MEETING THE REQUIREMENTS OF CLASS I, CLASS II, OR CLASS III MATERIAL AS DEFINED IN ASTM D2321. BEDDING & BACKFILL FOR SURFACE DRAINAGE INLETS SHALL BE PLACED & COMPACTED UNIFORMLY IN ACCORDANCE WITH ASTM D2321.

(4) VARIOUS TYPES OF INLET & OUTLET ADAPTERS AVAILABLE:
 4" - 18" FOR CORRUGATED HDPE (ADS N-12/HANCOR DUAL WALL, ADS/HANCOR SINGLE WALL), N-12 HP, PVC SEWER (EX: SDR 35), PVC DWV/ EX: SCH 40), PVC C900/C905, CORRUGATED & RIBBED PVC

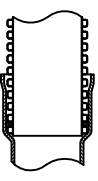

- 1 - GRATES/SOLID COVER SHALL BE DUCTILE IRON PER ASTM A536 GRADE 70-50-05.
- 2 - FRAMES SHALL BE DUCTILE IRON PER ASTM A536 GRADE 70-50-05.
- 3 - DRAIN BASIN TO BE CUSTOM MANUFACTURED ACCORDING TO PLAN DETAILS. RISERS ARE NEEDED FOR BASINS OVER 84" DUE TO SHIPPING RESTRICTIONS. SEE DRAWING NO. 7001-110-065.
- 4 - DRAINAGE CONNECTION STUB JOINT TIGHTNESS SHALL CONFORM TO ASTM D3212 FOR CORRUGATED HDPE (ADS N-12/HANCOR DUAL WALL), N-12 HP, & PVC SEWER.
- 5 - ADAPTERS CAN BE MOUNTED ON ANY ANGLE 0° TO 360°. TO DETERMINE MINIMUM ANGLE BETWEEN ADAPTERS SEE DRAWING NO. 7001-110-012.

GRATE OPTIONS	LOAD RATING	PART #	DRAWING #
PEDESTRIAN	MEETS H-10	1899CGP	7001-110-212
STANDARD	MEETS H-20	1899CGS	7001-110-213
SOLID COVER	MEETS H-20	1899CGC	7001-110-214
DOME	N/A	1899CGD	7001-110-215
DROP IN GRATE			1801DI 7001-110-074

THIS PRINT DISCLOSES SUBJECT MATTER IN WHICH NYLOPLAST HAS PROPRIETARY RIGHTS. THE RECEIPT OR POSSESSION OF THIS PRINT DOES NOT CONFER, TRANSFER, OR LICENSE THE USE OF THE DESIGN OR TECHNICAL INFORMATION SHOWN HEREIN. REPRODUCTION OF THIS PRINT OR ANY INFORMATION CONTAINED HEREIN, OR MANUFACTURE OF ANY ARTICLE HEREFROM, FOR THE DISCLOSURE TO OTHERS IS FORBIDDEN, EXCEPT BY SPECIFIC WRITTEN PERMISSION FROM NYLOPLAST.

DRAWN BY EBC	MATERIAL		3130 VERONA AVE BUFORD, GA 30518 PHN (770) 932-2443 FAX (770) 932-2480 www.nyloplast-us.com
DATE 04-03-06			
REVISD BY NMH	PROJECT NO./NAME	18 IN DRAIN BASIN QUICK SPEC INSTALLATION DETAIL	7001-110-191
DATE 03-14-16			
DWG SIZE A	SCALE 1:30	SHEET 1 OF 1	REV E

18", 24", & 30" DRAIN
 BASIN FRAME & GRATE
 (18" STD GRATE SHOWN)

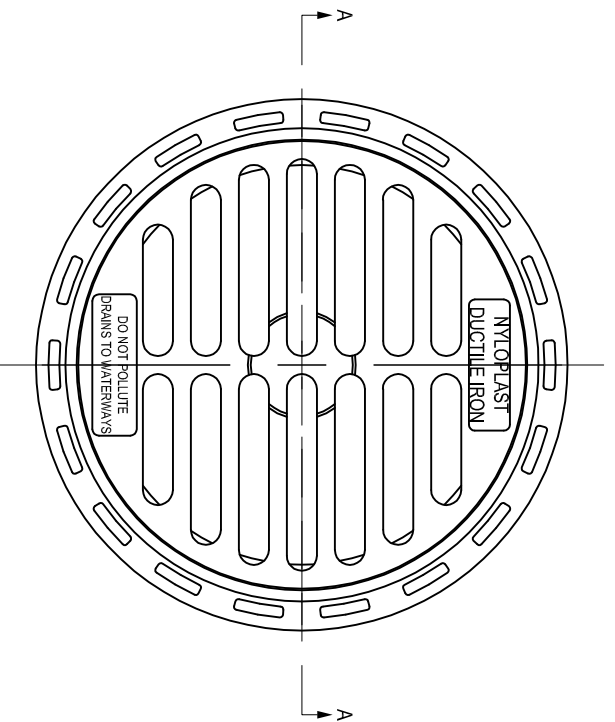

1899CG
 2499CG
 3099CG

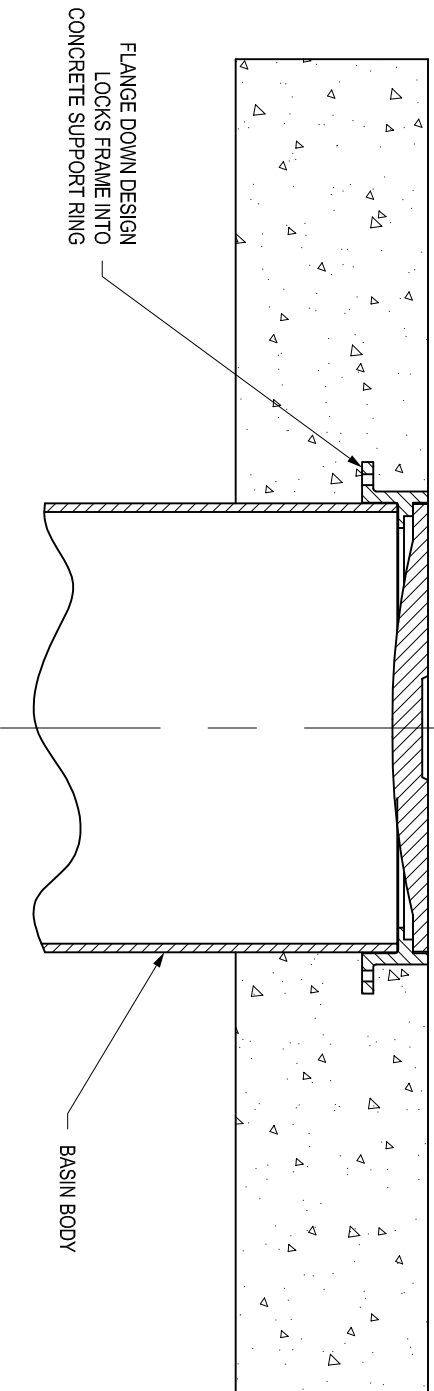

SECTION A - A

THIS PRINT DISCLOSES SUBJECT MATTER IN WHICH NYLOPLAST HAS PROPRIETARY RIGHTS. THE RECEIPT OR POSSESSION OF THIS PRINT DOES NOT CONFER, TRANSFER, OR LICENSE THE USE OF THE DESIGN OR TECHNICAL INFORMATION SHOWN HEREIN. REPRODUCTION OF THIS PRINT OR ANY INFORMATION CONTAINED HEREIN, OR MANUFACTURE OF ANY ARTICLE HEREFROM, FOR THE DISCLOSURE TO OTHERS IS FORBIDDEN, EXCEPT BY SPECIFIC WRITTEN PERMISSION FROM NYLOPLAST.

DRAWN BY	CJA	MATERIAL
DATE	12-10-99	
APPD BY	CJA	PROJECT NO./NAME
DATE	12-10-99	
DWG SIZE	A	SCALE
		1:8
		SHEET
		1 OF 1

	3130 VERONA AVE BUFORD, GA 30518 PHN (770) 932-2443 FAX (770) 932-2490 www.nyloplast-us.com
	TITLE 18 IN, 24 IN, & 30 IN FRAME & GRATE EXAMPLE
DWG NO.	7001-110-005
REV	D

12" @ 1% Capacity

Project Description

Friction Method	Manning Formula
Solve For	Full Flow Capacity

Input Data

Roughness Coefficient	0.013	
Channel Slope	0.01000	ft/ft
Normal Depth	1.00	ft
Diameter	1.00	ft
Discharge	3.56	ft ³ /s

Results

Discharge	3.56	ft ³ /s
Normal Depth	1.00	ft
Flow Area	0.79	ft ²
Wetted Perimeter	3.14	ft
Hydraulic Radius	0.25	ft
Top Width	0.00	ft
Critical Depth	0.81	ft
Percent Full	100.0	%
Critical Slope	0.01032	ft/ft
Velocity	4.54	ft/s
Velocity Head	0.32	ft
Specific Energy	1.32	ft
Froude Number	0.00	
Maximum Discharge	3.83	ft ³ /s
Discharge Full	3.56	ft ³ /s
Slope Full	0.01000	ft/ft
Flow Type	SubCritical	

GVF Input Data

Downstream Depth	0.00	ft
Length	0.00	ft
Number Of Steps	0	

GVF Output Data

Upstream Depth	0.00	ft
Profile Description		
Profile Headloss	0.00	ft
Average End Depth Over Rise	0.00	%

12" @ 1% Capacity

GVF Output Data

Normal Depth Over Rise	100.00	%
Downstream Velocity	Infinity	ft/s
Upstream Velocity	Infinity	ft/s
Normal Depth	1.00	ft
Critical Depth	0.81	ft
Channel Slope	0.01000	ft/ft
Critical Slope	0.01032	ft/ft

18" @ 1% Capacity

Project Description

Friction Method	Manning Formula
Solve For	Full Flow Capacity

Input Data

Roughness Coefficient	0.013	
Channel Slope	0.01000	ft/ft
Normal Depth	1.50	ft
Diameter	1.50	ft
Discharge	10.50	ft ³ /s

Results

Discharge	10.50	ft ³ /s
Normal Depth	1.50	ft
Flow Area	1.77	ft ²
Wetted Perimeter	4.71	ft
Hydraulic Radius	0.38	ft
Top Width	0.00	ft
Critical Depth	1.25	ft
Percent Full	100.0	%
Critical Slope	0.00977	ft/ft
Velocity	5.94	ft/s
Velocity Head	0.55	ft
Specific Energy	2.05	ft
Froude Number	0.00	
Maximum Discharge	11.30	ft ³ /s
Discharge Full	10.50	ft ³ /s
Slope Full	0.01000	ft/ft
Flow Type	SubCritical	

GVF Input Data

Downstream Depth	0.00	ft
Length	0.00	ft
Number Of Steps	0	

GVF Output Data

Upstream Depth	0.00	ft
Profile Description		
Profile Headloss	0.00	ft
Average End Depth Over Rise	0.00	%

18" @ 1% Capacity

GVF Output Data

Normal Depth Over Rise	100.00	%
Downstream Velocity	Infinity	ft/s
Upstream Velocity	Infinity	ft/s
Normal Depth	1.50	ft
Critical Depth	1.25	ft
Channel Slope	0.01000	ft/ft
Critical Slope	0.00977	ft/ft

Curb Chase Capacity

Project Description

Friction Method	Manning Formula
Solve For	Normal Depth

Input Data

Roughness Coefficient	0.013	
Channel Slope	0.02000	ft/ft
Bottom Width	2.00	ft
Discharge	1.07	ft ³ /s

Results

Normal Depth	0.14	ft
Flow Area	0.27	ft ²
Wetted Perimeter	2.27	ft
Hydraulic Radius	0.12	ft
Top Width	2.00	ft
Critical Depth	0.21	ft
Critical Slope	0.00535	ft/ft
Velocity	3.93	ft/s
Velocity Head	0.24	ft
Specific Energy	0.38	ft
Froude Number	1.88	
Flow Type	Supercritical	

GVF Input Data

Downstream Depth	0.00	ft
Length	0.00	ft
Number Of Steps	0	

GVF Output Data

Upstream Depth	0.00	ft
Profile Description		
Profile Headloss	0.00	ft
Downstream Velocity	Infinity	ft/s
Upstream Velocity	Infinity	ft/s
Normal Depth	0.14	ft
Critical Depth	0.21	ft
Channel Slope	0.02000	ft/ft
Critical Slope	0.00535	ft/ft

Basin PR-6 Swale

Project Description

Friction Method Manning Formula
Solve For Normal Depth

Input Data

Roughness Coefficient	0.035	
Channel Slope	0.04000	ft/ft
Left Side Slope	3.00	ft/ft (H:V)
Right Side Slope	3.00	ft/ft (H:V)
Discharge	1.00	ft ³ /s

Results

Normal Depth	0.36	ft
Flow Area	0.38	ft ²
Wetted Perimeter	2.26	ft
Hydraulic Radius	0.17	ft
Top Width	2.15	ft
Critical Depth	0.37	ft
Critical Slope	0.03362	ft/ft
Velocity	2.60	ft/s
Velocity Head	0.11	ft
Specific Energy	0.46	ft
Froude Number	1.08	
Flow Type	Supercritical	

Note: Flow reduced from PR-6 basin flow since swale only captures small portion of landscaped flows

GVF Input Data

Downstream Depth	0.00	ft
Length	0.00	ft
Number Of Steps	0	

GVF Output Data

Upstream Depth	0.00	ft
Profile Description		
Profile Headloss	0.00	ft
Downstream Velocity	Infinity	ft/s
Upstream Velocity	Infinity	ft/s
Normal Depth	0.36	ft
Critical Depth	0.37	ft
Channel Slope	0.04000	ft/ft
Critical Slope	0.03362	ft/ft

Basin PR-8 Swale

Project Description

Friction Method	Manning Formula
Solve For	Normal Depth

Input Data

Roughness Coefficient	0.035	
Channel Slope	0.02000	ft/ft
Left Side Slope	3.00	ft/ft (H:V)
Right Side Slope	3.00	ft/ft (H:V)
Discharge	0.20	ft ³ /s

Results

Normal Depth	0.22	ft
Flow Area	0.15	ft ²
Wetted Perimeter	1.41	ft
Hydraulic Radius	0.11	ft
Top Width	1.34	ft
Critical Depth	0.19	ft
Critical Slope	0.04167	ft/ft
Velocity	1.34	ft/s
Velocity Head	0.03	ft
Specific Energy	0.25	ft
Froude Number	0.71	
Flow Type	Subcritical	

GVF Input Data

Downstream Depth	0.00	ft
Length	0.00	ft
Number Of Steps	0	

GVF Output Data

Upstream Depth	0.00	ft
Profile Description		
Profile Headloss	0.00	ft
Downstream Velocity	Infinity	ft/s
Upstream Velocity	Infinity	ft/s
Normal Depth	0.22	ft
Critical Depth	0.19	ft
Channel Slope	0.02000	ft/ft
Critical Slope	0.04167	ft/ft

APPENDIX E

Pond Computations

Site-Level Low Impact Development (LID) Design Effective Impervious Calculator

LID Credit by Impervious Reduction Factor (IRF) Method

LID-SMTR (Version 3.06, November 2016)

User Input

Calculated cells

---Design Storm: 1-Hour Rain Depth: **WQCV Event** 0.60
 ---Minor Storm: 1-Hour Rain Depth: **5-Year Event** 1.50
 ---Major Storm: 1-Hour Rain Depth: **100-Year Event** 2.52

Optional User Defined Storm
 (CHP) NOAA 1-Hour Rainfall Depth and Frequency for User Defined Storm: **CHP** 100-Year Event

Max Intensity for Optional User Defined Storm:

Designer: **DDJ**
 Company: **Galloway & Co.**
 Date: **July 8, 2022**
 Project: **6855 Constitution Ave Self Storage**
 Location: **FSD**

SITE INFORMATION (USER-INPUT)

Sub-basin Identifier	PR-5	PR-6	PR-7	PR-8	PR-9	PR-10
Receiving Previous Area Soil Type	Sandy Loam	Sandy Loam	Sandy Loam	Sandy Loam	Sandy Loam	Sandy Loam
Total Area (ac., Sum of DCA, U/A, RPA, & SPA)	1.320	0.830	0.190	0.130	0.180	0.310
Directly Connected Impervious Area (DCA, acres)	1.320	0.490	0.170	0.000	0.170	0.000
Unconnected Impervious Area (UIA, acres)	0.000	0.000	0.000	0.000	0.000	0.000
Receiving Previous Area (RPA, acres)	0.000	0.000	0.000	0.000	0.000	0.000
Separate Previous Area (SPA, acres)	0.000	0.340	0.020	0.130	0.010	0.310
RPA Treatment Type: Conveyance (C), Volume (V), or Permeable Pavement (P)	C	C	C	C	C	C

CALCULATED RESULTS (OUTPUT)

Total Calculated Area (ac, check against input)	1.320	0.830	0.190	0.130	0.180	0.310
Directly Connected Impervious Area (DCA, %)	100.0%	59.0%	89.5%	0.0%	94.4%	0.0%
Unconnected Impervious Area (UIA, %)	0.0%	0.0%	0.0%	0.0%	0.0%	0.0%
Receiving Previous Area (RPA, %)	0.0%	0.0%	0.0%	0.0%	0.0%	0.0%
Separate Previous Area (SPA, %)	0.0%	41.0%	10.5%	100.0%	5.6%	100.0%
A _i (RPA / UIA)	0.000	0.000	0.000	0.000	0.000	0.000
I _i Check	1.000	1.000	1.000	1.000	1.000	1.000
f / f for WQCV Event:	1.7	1.7	1.7	1.7	1.7	1.7
f / f for 5-Year Event:	0.5	0.5	0.5	0.5	0.5	0.5
f / f for 100-Year Event:	0.3	0.3	0.3	0.3	0.3	0.3
f / f for Optional User Defined Storm CHP:						
IRF for WQCV Event:	1.00	1.00	1.00	1.00	1.00	1.00
IRF for 5-Year Event:	1.00	1.00	1.00	1.00	1.00	1.00
IRF for 100-Year Event:	1.00	1.00	1.00	1.00	1.00	1.00
IRF for Optional User Defined Storm CHP:						
Total Site Imperviousness: I _{tot}	100.0%	59.0%	89.5%	0.0%	94.4%	0.0%
Effective Imperviousness for WQCV Event:	100.0%	59.0%	89.5%	0.0%	94.4%	0.0%
Effective Imperviousness for 5-Year Event:	100.0%	59.0%	89.5%	0.0%	94.4%	0.0%
Effective Imperviousness for 100-Year Event:	100.0%	59.0%	89.5%	0.0%	94.4%	0.0%
Effective Imperviousness for Optional User Defined Storm CHP:						

LID / EFFECTIVE IMPERVIOUSNESS CREDITS

WQCV Event CREDIT: Reduce Detention By	100-Year Event CREDIT** Reduce Detention By	User Defined CHP CREDIT: Reduce Detention By	Total Site Imperviousness:	Notes:
N/A	N/A	N/A	72.6%	* Green-Ampt average infiltration rate values from Table 3.3.
0.0%	0.0%	0.0%	72.6%	** Flood control detention volume credits based on empirical equations from Storage Chapter of USDCM.
N/A	N/A	0.1%	72.6%	*** Method assumes that 1-hour rainfall depth is equivalent to 1-hour intensity for calculation purposed

Stormwater Detention and Infiltration Design Data Sheet

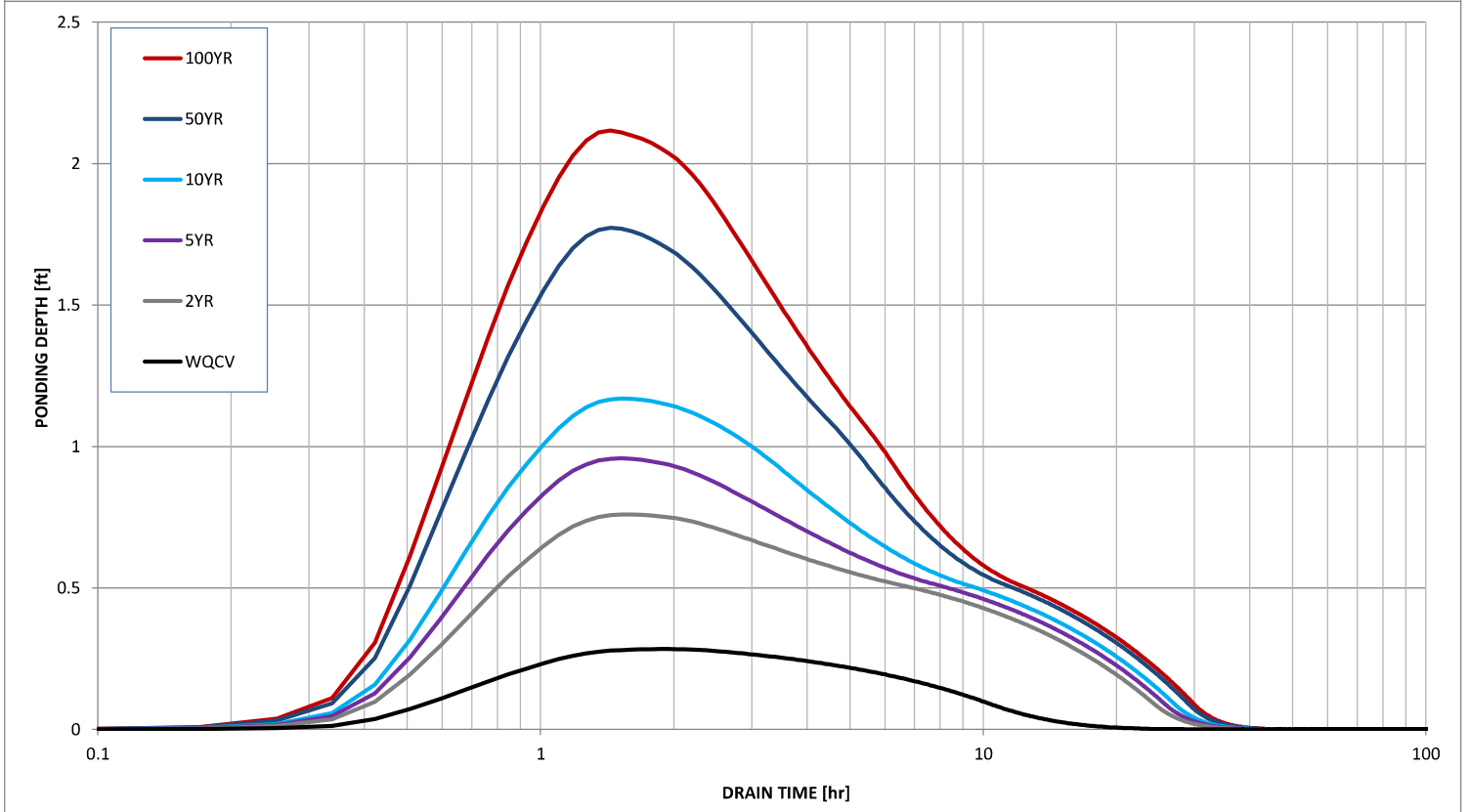
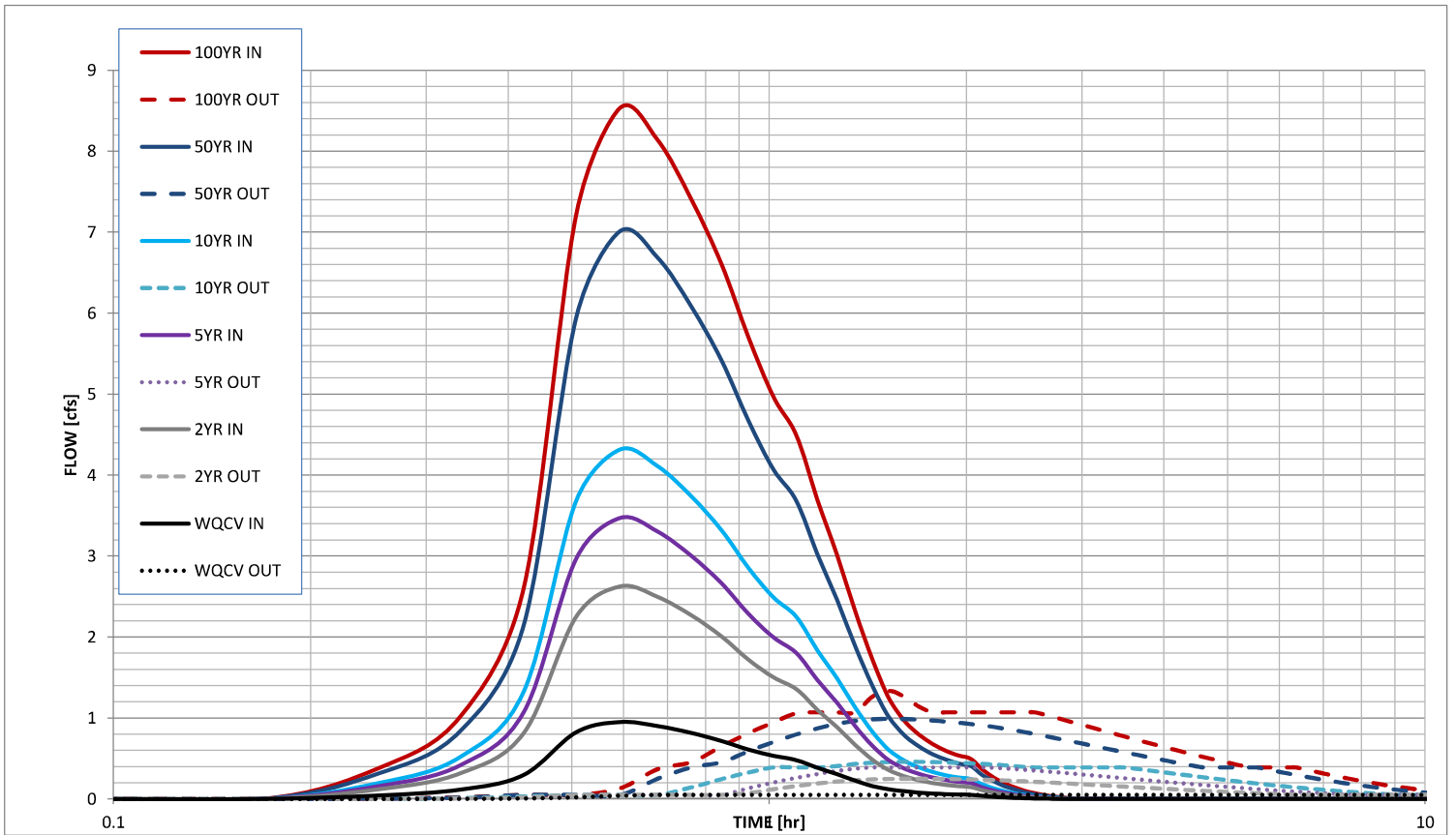

Design Procedure Form: Sand Filter (SF)

UD-BMP (Version 3.06, November 2016)

Sheet 1 of 2

Designer: DDJ
Company: Galloway
Date: July 8, 2022
Project: 6955 Constitution Ave Self Storage
Location: _____

<p>1. Basin Storage Volume</p> <p>A) Effective Imperviousness of Tributary Area, I_a (100% if all paved and roofed areas upstream of sand filter)</p> <p>B) Tributary Area's Imperviousness Ratio ($i = I_a/100$)</p> <p>C) Water Quality Capture Volume (WQCV) Based on 12-hour Drain Time $WQCV = 0.8 * (0.91 * i^3 - 1.19 * i^2 + 0.78 * i)$</p> <p>D) Contributing Watershed Area (including sand filter area)</p> <p>E) Water Quality Capture Volume (WQCV) Design Volume $V_{WQCV} = WQCV / 12 * Area$</p> <p>F) For Watersheds Outside of the Denver Region, Depth of Average Runoff Producing Storm</p> <p>G) For Watersheds Outside of the Denver Region, Water Quality Capture Volume (WQCV) Design Volume</p> <p>H) User Input of Water Quality Capture Volume (WQCV) Design Volume (Only if a different WQCV Design Volume is desired)</p>	<p>$I_a =$ <u>72.6</u> %</p> <p>$i =$ <u>0.726</u></p> <p>WQCV = <u>0.23</u> watershed inches</p> <p>Area = <u>128,938</u> sq ft</p> <p>$V_{WQCV} =$ <u>2,469</u> cu ft</p> <p>$d_6 =$ _____ in</p> <p>$V_{WQCV\ OTHER} =$ _____ cu ft</p> <p>$V_{WQCV\ USER} =$ _____ cu ft</p>
<p>2. Basin Geometry</p> <p>A) WQCV Depth</p> <p>B) Sand Filter Side Slopes (Horizontal distance per unit vertical, 4:1 or flatter preferred). Use "0" if sand filter has vertical walls.</p> <p>C) Minimum Filter Area (Flat Surface Area)</p> <p>D) Actual Filter Area</p> <p>E) Volume Provided</p>	<p>$D_{WQCV} =$ <u>0.46</u> ft</p> <p>$Z =$ <u>50.00</u> ft / ft</p> <p>$A_{Min} =$ <u>1170</u> sq ft</p> <p>$A_{Actual} =$ <u>2500</u> sq ft</p> <p>$V_T =$ <u>4478</u> cu ft</p>
<p>3. Filter Material</p>	<div style="border: 1px solid black; padding: 5px;"> <p>Choose One</p> <p><input checked="" type="radio"/> 18" CDOT Class B or C Filter Material</p> <p><input type="radio"/> Other (Explain):</p> <p>_____</p> <p>_____</p> </div>
<p>4. Underdrain System</p> <p>A) Are underdrains provided?</p> <p>B) Underdrain system orifice diameter for 12 hour drain time</p> <p style="margin-left: 20px;">i) Distance From Lowest Elevation of the Storage Volume to the Center of the Orifice</p> <p style="margin-left: 20px;">ii) Volume to Drain in 12 Hours</p> <p style="margin-left: 20px;">iii) Orifice Diameter, 3/8" Minimum</p>	<div style="border: 1px solid black; padding: 5px;"> <p>Choose One</p> <p><input type="radio"/> YES</p> <p><input checked="" type="radio"/> NO</p> </div> <p>$y =$ <u>N/A</u> ft</p> <p>$Vol_{12} =$ <u>N/A</u> cu ft</p> <p>$D_o =$ <u>N/A</u> in</p>

Design Procedure Form: Sand Filter (SF)

Sheet 2 of 2

Designer: DDJ
Company: Galloway
Date: July 8, 2022
Project: 6955 Constitution Ave Self Storage
Location: _____

5. Impermeable Geomembrane Liner and Geotextile Separator Fabric

A) Is an impermeable liner provided due to proximity of structures or groundwater contamination?

Choose One
 YES NO

6-7. Inlet / Outlet Works

A) Describe the type of energy dissipation at inlet points and means of conveying flows in excess of the WQCV through the outlet

Notes: _____

SWMM Layout

ColoradoSprings

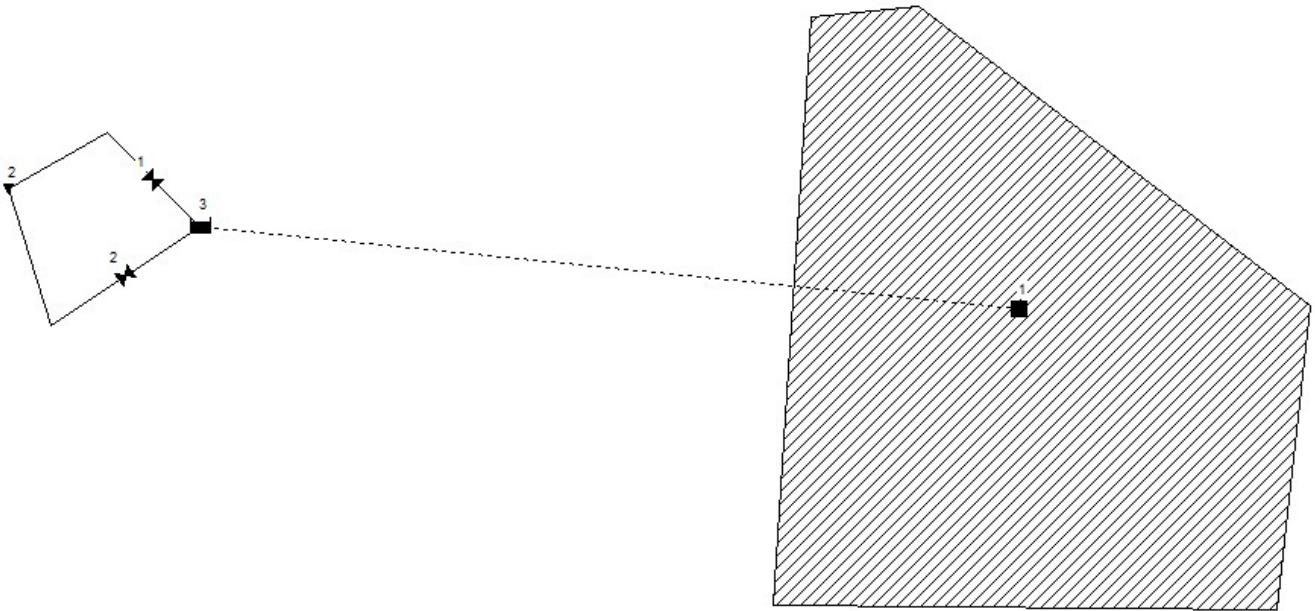

SWMM Input Summary

```

1  [TITLE]
2  ;;Project Title/Notes
3
4  [OPTIONS]
5  ;;Option      Value
6  FLOW_UNITS    CFS
7  INFILTRATION  HORTON
8  FLOW_ROUTING  KINWAVE
9  LINK_OFFSETS  DEPTH
10 MIN_SLOPE      0
11 ALLOW_PONDING NO
12 SKIP_STEADY_STATE NO
13
14 START_DATE     04/20/2022
15 START_TIME     00:00:00
16 REPORT_START_DATE 04/20/2022
17 REPORT_START_TIME 00:00:00
18 END_DATE       04/24/2022
19 END_TIME       00:00:00
20 SWEEP_START    01/01
21 SWEEP_END      12/31
22 DRY_DAYS       0
23 REPORT_STEP    00:15:00
24 WET_STEP       00:05:00
25 DRY_STEP       01:00:00
26 ROUTING_STEP   0:00:30
27 RULE_STEP      00:00:00
28
29 INERTIAL_DAMPING PARTIAL
30 NORMAL_FLOW_LIMITED BOTH
31 FORCE_MAIN_EQUATION H-W
32 VARIABLE_STEP   0.75
33 LENGTHENING_STEP 0
34 MIN_SURFAREA    12.566
35 MAX_TRIALS      8
36 HEAD_TOLERANCE  0.005
37 SYS_FLOW_TOL    5
38 LAT_FLOW_TOL    5
39 MINIMUM_STEP    0.5
40 THREADS         1
41
42 [EVAPORATION]
43 ;;Data Source  Parameters
44 ;;-----
45 CONSTANT      0.0
46 DRY_ONLY      NO
47
48 [RAINGAGES]
49 ;;Name        Format      Interval SCF      Source
50 ;;-----
51 ColoradoSprings CUMULATIVE 0:05      1.0      TIMESERIES 100yr
52
53 [SUBCATCHMENTS]
54 ;;Name        Rain Gage      Outlet      Area      %Imperv  Width  %Slope
55 CurbLen  SnowPack
56 ;;-----
57
58 1           ColoradoSprings 3           2.96      72.6      20      2
59 0
60
61 [SUBAREAS]
62 ;;Subcatchment N-Imperv  N-Perv  S-Imperv  S-Perv  PctZero  RouteTo
63 PctRouted
64 ;;-----
65 1           .011     .24     .1        .35     25       OUTLET
66
67 [INFILTRATION]
68 ;;Subcatchment Param1    Param2    Param3    Param4    Param5

```

```

65 ;;-----
66 1          5          1          2.52      7          0
67
68 [OUTFALLS]
69 ;;Name      Elevation  Type      Stage Data      Gated      Route To
70 ;;-----
71 2          0          FREE          NO
72
73 [STORAGE]
74 ;;Name      Elev.      MaxDepth  InitDepth  Shape      Curve Name/Params
75 N/A      Fevap      Psi      Ksat      IMD
76 ;;-----
77
78 3          0          5          0          TABULAR    FSB-1
79 0          0          0          .29      0
80
81 [ORIFICES]
82 ;;Name      From Node      To Node      Type      Offset      Qcoeff
83 Gated      CloseTime
84 ;;-----
85
86 1          3          2          SIDE      .51      0.65
87 NO          0
88
89 [OUTLETS]
90 ;;Name      From Node      To Node      Offset      Type
91 QTable/Qcoeff  Qexpon      Gated
92 ;;-----
93
94 2          3          2          2.09      FUNCTIONAL/DEPTH
95 10.0      0.5          NO
96
97 [XSECTIONS]
98 ;;Link      Shape      Geom1      Geom2      Geom3      Geom4
99 Barrels      Culvert
100 ;;-----
101
102 1          CIRCULAR    .5          0          0          0
103
104 [CURVES]
105 ;;Name      Type      X-Value      Y-Value
106 ;;-----
107 OutletStructure Rating      0.00      0.00
108 OutletStructure      0.20      2.66
109 OutletStructure      0.40      7.53
110 OutletStructure      0.60      11.02
111 OutletStructure      0.80      11.77
112 OutletStructure      1.00      12.47
113 OutletStructure      1.20      13.13
114 OutletStructure      1.40      13.77
115 OutletStructure      1.60      14.37
116 OutletStructure      1.80      14.95
117 OutletStructure      2.00      15.51
118 OutletStructure      2.20      16.05
119 OutletStructure      2.40      16.57
120 OutletStructure      2.60      17.07
121 OutletStructure      2.80      17.56
122 OutletStructure      3.00      18.04
123 ;
124 FSB-1      Storage      0          6985
125 FSB-1      0.09      7526.48
126 FSB-1      1.09      8825.82
127 FSB-1      2.09      9119.29
128 FSB-1      3.09      9302.02
129 FSB-1      4.09      9464.61
130 FSB-1      5.09      9627
131
132 [TIMESERIES]
133 ;;Name      Date      Time      Value

```

123	;;		
124	5-yr	0:00	0
125	5-yr	0:05	0.01778
126	5-yr	0:10	0.05842
127	5-yr	0:15	0.10033
128	5-yr	0:20	0.1524
129	5-yr	0:25	0.22733
130	5-yr	0:30	0.32766
131	5-yr	0:35	0.53467
132	5-yr	0:40	0.90424
133	5-yr	0:45	1.04648
134	5-yr	0:50	1.13284
135	5-yr	0:55	1.18745
136	5-yr	1:00	1.23444
137	5-yr	1:05	1.27508
138	5-yr	1:10	1.29286
139	5-yr	1:15	1.3081
140	5-yr	1:20	1.32207
141	5-yr	1:25	1.33604
142	5-yr	1:30	1.35001
143	5-yr	1:35	1.36144
144	5-yr	1:40	1.37414
145	5-yr	1:45	1.38557
146	5-yr	1:50	1.397
147	5-yr	1:55	1.40843
148	5-yr	2:00	1.42113
149	;		
150	WQ	0:00	0
151	WQ	0:05	0.0084
152	WQ	0:10	0.0276
153	WQ	0:15	0.0474
154	WQ	0:20	0.072
155	WQ	0:25	0.1074
156	WQ	0:30	0.1548
157	WQ	0:35	0.2526
158	WQ	0:40	0.4272
159	WQ	0:45	0.4944
160	WQ	0:50	0.5352
161	WQ	0:55	0.561
162	WQ	1:00	0.5832
163	WQ	1:05	0.6024
164	WQ	1:10	0.6108
165	WQ	1:15	0.618
166	WQ	1:20	0.6246
167	WQ	1:25	0.6312
168	WQ	1:30	0.6378
169	WQ	1:35	0.6432
170	WQ	1:40	0.6492
171	WQ	1:45	0.6546
172	WQ	1:50	0.66
173	WQ	1:55	0.6654
174	WQ	2:00	0.6714
175	;		
176	100yr	0:00	0
177	100yr	0:05	0.03738
178	100yr	0:10	0.12282
179	100yr	0:15	0.21093
180	100yr	0:20	0.3204
181	100yr	0:25	0.47793
182	100yr	0:30	0.68886
183	100yr	0:35	1.12407
184	100yr	0:40	1.90104
185	100yr	0:45	2.20008
186	100yr	0:50	2.38164
187	100yr	0:55	2.49645
188	100yr	1:00	2.59524
189	100yr	1:05	2.68068
190	100yr	1:10	2.71806
191	100yr	1:15	2.7501

192	100yr	1:20	2.77947
193	100yr	1:25	2.80884
194	100yr	1:30	2.83821
195	100yr	1:35	2.86224
196	100yr	1:40	2.88894
197	100yr	1:45	2.91297
198	100yr	1:50	2.937
199	100yr	1:55	2.96103
200	100yr	2:00	2.98773

201
202 [REPORT]
203 ;;Reporting Options
204 SUBCATCHMENTS ALL
205 NODES ALL
206 LINKS ALL

207
208 [TAGS]

209
210 [MAP]
211 DIMENSIONS 0.000 0.000 10000.000 10000.000
212 Units None

213
214 [COORDINATES]
215 ;;Node X-Coord Y-Coord
216 ;;-----
217 2 -972.461 6075.731
218 3 -266.781 5938.038

219
220 [VERTICES]
221 ;;Link X-Coord Y-Coord
222 ;;-----
223 1 -611.015 6282.272
224 2 -817.556 5576.592

225
226 [Polygons]
227 ;;Subcatchment X-Coord Y-Coord
228 ;;-----
229 1 2383.821 6746.988
230 1 3829.604 5645.439
231 1 3709.122 4526.678
232 1 1850.258 4543.890
233 1 1987.952 6712.565

234
235 [SYMBOLS]
236 ;;Gage X-Coord Y-Coord
237 ;;-----
238 ColoradoSprings 834.768 7228.916

239
240

Time to Drain WQCV

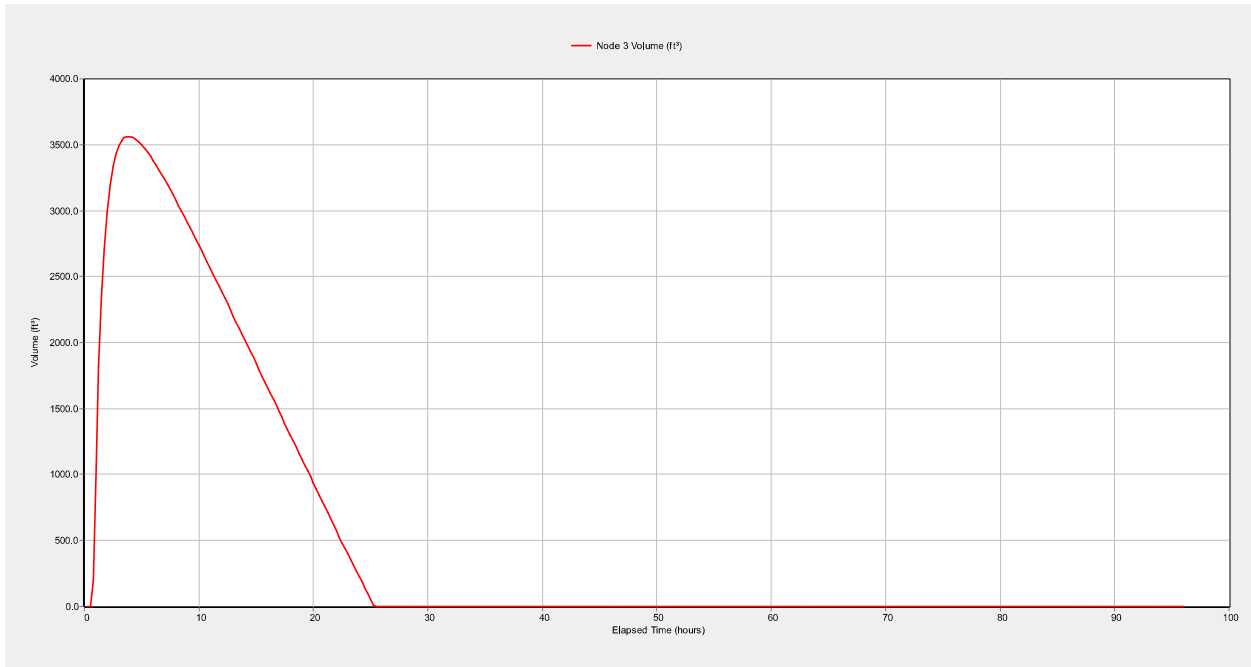

Water Quality Storm Report

 NOTE: The summary statistics displayed in this report are based on results found at every computational time step, not just on results from each reporting time step.

 Analysis Options

 Flow Units CFS
 Process Models:
 Rainfall/Runoff YES
 RDII NO
 Snowmelt NO
 Groundwater NO
 Flow Routing YES
 Ponding Allowed NO
 Water Quality NO
 Infiltration Method HORTON
 Flow Routing Method KINWAVE
 Starting Date 04/20/2022 00:00:00
 Ending Date 04/24/2022 00:00:00
 Antecedent Dry Days 0.0
 Report Time Step 00:15:00
 Wet Time Step 00:05:00
 Dry Time Step 01:00:00
 Routing Time Step 30.00 sec

	Volume acre-feet	Depth inches

Total Precipitation	0.166	0.671
Evaporation Loss	0.000	0.000
Infiltration Loss	0.045	0.184
Surface Runoff	0.107	0.434
Final Storage	0.014	0.055
Continuity Error (%)	-0.165	

	Volume acre-feet	Volume 10 ⁶ gal

Dry Weather Inflow	0.000	0.000
Wet Weather Inflow	0.107	0.035
Groundwater Inflow	0.000	0.000
RDII Inflow	0.000	0.000
External Inflow	0.000	0.000
External Outflow	0.000	0.000
Flooding Loss	0.000	0.000
Evaporation Loss	0.000	0.000
Exfiltration Loss	0.107	0.035
Initial Stored Volume	0.000	0.000
Final Stored Volume	0.000	0.000
Continuity Error (%)	0.000	

 Highest Flow Instability Indexes

 All links are stable.

```

70 Routing Time Step Summary
71 *****
72 Minimum Time Step      :    30.00 sec
73 Average Time Step      :    30.00 sec
74 Maximum Time Step      :    30.00 sec
75 Percent in Steady State :     0.00
76 Average Iterations per Step :     1.00
77 Percent Not Converging  :     0.00
78
79

```

```

80 *****
81 Subcatchment Runoff Summary
82 *****
83
84

```

```

-----
85                                     Total      Total      Total      Total      Imperv
86                                     Perv      Total      Total      Peak      Runoff
87                                     Precip    Runon     Evap      Infil     Runoff
88 Subcatchment                       Runoff    Runoff    Runoff    Runoff    Coeff
89 in      in      10^6 gal      CFS      in      in      in      in
-----

```

```

89 1      0.00      0.43      0.03      0.67      1.05      0.00      0.646      0.00      0.18      0.43
90
91

```

```

92 *****
93 Node Depth Summary
94 *****
95
96

```

```

-----
97                                     Average  Maximum  Maximum  Time of Max  Reported
98                                     Depth   Depth   HGL      Occurrence  Max Depth
99 Node      Type      Feet     Feet     Feet     days hr:min  Feet
-----
100
101 2      OUTFALL  0.00     0.00     0.00     0 00:00     0.00
102 3      STORAGE  0.07     0.46     0.46     0 03:52     0.46
103
104

```

```

105 *****
106 Node Inflow Summary
107 *****
108
109

```

```

-----
110                                     Maximum  Maximum  Lateral
111                                     Total    Flow
112                                     Lateral  Total  Time of Max  Inflow
113                                     Inflow  Balance  Occurrence  Volume
114                                     Inflow  Error   days hr:min  10^6 gal  10^6
115 Node      Type      CFS      CFS      CFS
116 gal      Percent
-----

```

```

115 2      OUTFALL  0.00     0.00     0 00:00     0
116 0      0.000 gal
117 3      STORAGE  1.05     1.05     0 00:55     0.0349
118 0.0349     -0.015
119

```

```

119 *****
120 Node Flooding Summary

```

121 *****
 122
 123 No nodes were flooded.
 124
 125
 126 *****
 127 Storage Volume Summary
 128 *****
 129
 130

```

-----
-----
131           Average      Avg  Evap Exfil           Maximum      Max      Time of
           Max      Maximum
132           Volume      Pcnt  Pcnt  Pcnt           Volume      Pcnt
           Occurrence      Outflow
133 Storage Unit      1000 ft3      Full  Loss  Loss           1000 ft3      Full      days
hr:min              CFS
134
-----
-----

```

```

135 3              0.514      1      0      100           3.563      8      0
03:51          0.05

```

136
 137
 138 *****
 139 Outfall Loading Summary
 140 *****
 141

```

-----
143           Flow      Avg      Max      Total
144           Freq      Flow      Flow      Volume
145 Outfall Node      Pcnt      CFS      CFS      10^6 gal
-----
146
147 2              0.00      0.00      0.00      0.000
-----
148
149 System          0.00      0.00      0.00      0.000
-----

```

151
 152 *****
 153 Link Flow Summary
 154 *****
 155

```

-----
157           Maximum      Time of Max      Maximum      Max/      Max/
158           |Flow|      Occurrence      |Veloc|      Full      Full
159 Link           Type      CFS      days hr:min      ft/sec      Flow      Depth
-----
160
161 1           ORIFICE      0.00      0 00:00
162 2           DUMMY      0.00      0 00:00
-----

```

163
 164
 165 *****
 166 Conduit Surcharge Summary
 167 *****
 168

169 No conduits were surcharged.
 170

171
 172 Analysis begun on: Fri Jul 8 16:22:44 2022
 173 Analysis ended on: Fri Jul 8 16:22:44 2022
 174 Total elapsed time: < 1 sec

5-Year Storm Report

 Analysis Options

Flow Units CFS
 Process Models:
 Rainfall/Runoff YES
 RDII NO
 Snowmelt NO
 Groundwater NO
 Flow Routing YES
 Ponding Allowed NO
 Water Quality NO
 Infiltration Method HORTON
 Flow Routing Method KINWAVE
 Starting Date 04/20/2022 00:00:00
 Ending Date 04/24/2022 00:00:00
 Antecedent Dry Days 0.0
 Report Time Step 00:15:00
 Wet Time Step 00:05:00
 Dry Time Step 01:00:00
 Routing Time Step 30.00 sec

*****	Volume	Depth
Runoff Quantity Continuity	acre-feet	inches
*****	-----	-----
Total Precipitation	0.351	1.421
Evaporation Loss	0.000	0.000
Infiltration Loss	0.096	0.389
Surface Runoff	0.242	0.980
Final Storage	0.014	0.055
Continuity Error (%)	-0.224	

*****	Volume	Volume
Flow Routing Continuity	acre-feet	10 ⁶ gal
*****	-----	-----
Dry Weather Inflow	0.000	0.000
Wet Weather Inflow	0.242	0.079
Groundwater Inflow	0.000	0.000
RDII Inflow	0.000	0.000
External Inflow	0.000	0.000
External Outflow	0.103	0.033
Flooding Loss	0.000	0.000
Evaporation Loss	0.000	0.000
Exfiltration Loss	0.139	0.045
Initial Stored Volume	0.000	0.000
Final Stored Volume	0.000	0.000
Continuity Error (%)	0.000	

 Highest Flow Instability Indexes

 All links are stable.

 Routing Time Step Summary

 Minimum Time Step : 30.00 sec
 Average Time Step : 30.00 sec
 Maximum Time Step : 30.00 sec
 % of Time in Steady State : 0.00

70 Average Iterations per Step : 1.00
 71 % of Steps Not Converging : 0.00

72
73
74
75
76
77
78

 Subcatchment Runoff Summary

```

-----
-----
79                               Total      Total      Total      Total      Imperv
80                               Perv      Total      Total      Peak      Runoff
81                               Precip    Runon     Evap      Infil      Runoff
82                               Runoff   Runoff    Runoff    Runoff    Coeff
83                               in        in        in        in        in
84                               10^6 gal  CFS
  
```

```

-----
-----
83 1                               1.42      0.00      0.00      0.39      0.98
84 0.00          0.98          0.08      3.35      0.690
  
```

85
86

 Node Depth Summary

87
88
89

```

-----
-----
91                               Average  Maximum  Maximum  Time of Max  Reported
92                               Depth   Depth    HGL      Occurrence   Max Depth
93                               Feet    Feet     Feet     days hr:min  Feet
94                               -----
95 2                               OUTFALL  0.00     0.00     0.00     0 00:00     0.00
96 3                               STORAGE  0.13     0.93     0.93     0 02:13     0.93
  
```

97
98
99

 Node Inflow Summary

100
101
102
103

```

-----
-----
104                               Maximum  Maximum  Lateral
105                               Total    Flow     Inflow
106                               Lateral Total  Time of Max  Inflow
107                               Inflow  Balance  Occurrence   Volume
108                               Volume  Error    days hr:min  10^6 gal  10^6
109                               Node
110                               gal    Percent  Type
  
```

```

-----
-----
109 2                               OUTFALL  0.00     0.39     0 02:13     0
110 0.0335        0.000
110 3                               STORAGE  3.35     3.35     0 00:50     0.0788
111 0.0788        0.005
  
```

111
112

 Node Flooding Summary

113
114
115
116
117 No nodes were flooded.

118
119
120

121 Storage Volume Summary
 122 *****
 123
 124

Storage Unit hr:min	CFS	Average Max Volume Occurrence 1000 ft3	Avg Maximum Pcnt Full	Evap Pcnt Loss	Exfil Pcnt Loss	Maximum Volume 1000 ft3	Max Pcnt Full	Time of days
3 02:12	0.45	0.977	2	0	58	7.408	16	0

130
 131
 132 *****
 133 Outfall Loading Summary
 134 *****
 135

Outfall Node	Flow Freq Pcnt	Avg Flow CFS	Max Flow CFS	Total Volume 10^6 gal
2	9.51	0.14	0.39	0.033
System	9.51	0.14	0.39	0.033

145
 146 *****
 147 Link Flow Summary
 148 *****
 149

Link	Type	Maximum Flow CFS	Time of Max Occurrence days hr:min	Maximum Veloc ft/sec	Max/ Full Flow	Max/ Full Depth
1	ORIFICE	0.39	0 02:13			0.00
2	DUMMY	0.00	0 00:00			

158
 159 *****
 160 Conduit Surcharge Summary
 161 *****
 162

163 No conduits were surcharged.

164
 165
 166 Analysis begun on: Fri Jul 8 16:58:35 2022
 167 Analysis ended on: Fri Jul 8 16:58:35 2022
 168 Total elapsed time: < 1 sec

100-Year Storm Report

Analysis Options

Flow Units CFS

Process Models:

Rainfall/Runoff YES
 RDII NO
 Snowmelt NO
 Groundwater NO
 Flow Routing YES
 Ponding Allowed NO
 Water Quality NO
 Infiltration Method HORTON
 Flow Routing Method KINWAVE
 Starting Date 04/20/2022 00:00:00
 Ending Date 04/24/2022 00:00:00
 Antecedent Dry Days 0.0
 Report Time Step 00:15:00
 Wet Time Step 00:05:00
 Dry Time Step 01:00:00
 Routing Time Step 30.00 sec

*****	Volume	Depth
Runoff Quantity Continuity	acre-feet	inches
*****	-----	-----
Total Precipitation	0.737	2.988
Evaporation Loss	0.000	0.000
Infiltration Loss	0.200	0.811
Surface Runoff	0.526	2.131
Final Storage	0.014	0.055
Continuity Error (%)	-0.308	

*****	Volume	Volume
Flow Routing Continuity	acre-feet	10 ⁶ gal
*****	-----	-----
Dry Weather Inflow	0.000	0.000
Wet Weather Inflow	0.526	0.171
Groundwater Inflow	0.000	0.000
RDII Inflow	0.000	0.000
External Inflow	0.000	0.000
External Outflow	0.375	0.122
Flooding Loss	0.000	0.000
Evaporation Loss	0.000	0.000
Exfiltration Loss	0.150	0.049
Initial Stored Volume	0.000	0.000
Final Stored Volume	0.000	0.000
Continuity Error (%)	0.051	

Highest Flow Instability Indexes

All links are stable.

Routing Time Step Summary

Minimum Time Step : 30.00 sec
 Average Time Step : 30.00 sec
 Maximum Time Step : 30.00 sec
 % of Time in Steady State : 0.00

70 Average Iterations per Step : 1.00
 71 % of Steps Not Converging : 0.00

72
73
74
75
76
77
78

 Subcatchment Runoff Summary

```

-----
-----
79                               Total      Total      Total      Total      Imperv
80                               Perv      Total      Total      Peak      Runoff
81                               Precip    Runon     Evap      Infil      Runoff
82                               Runoff   Runoff   Runoff   Runoff   Coeff
83                               in        in        in        in        in
84                               10^6 gal  CFS
  
```

```

-----
-----
83 1                               2.99      0.00      0.00      0.81      2.12
84 0.01          2.13          0.17      9.76      0.713
  
```

85
86

 Node Depth Summary

87
88
89

```

-----
-----
91                               Average  Maximum  Maximum  Time of Max  Reported
92                               Depth   Depth   HGL      Occurrence  Max Depth
93                               Feet    Feet    Feet     days hr:min  Feet
94                               -----
95 2                               OUTFALL  0.00     0.00     0.00     0 00:00     0.00
96 3                               STORAGE  0.18     1.86     1.86     0 01:53     1.86
  
```

97
98
99

 Node Inflow Summary

100
101
102
103

```

-----
-----
104                               Maximum  Maximum  Lateral
105                               Total    Flow     Inflow
106                               Lateral Total  Time of Max  Inflow
107                               Inflow  Balance  Occurrence  Volume
108                               Volume  Error   days hr:min  10^6 gal  10^6
109                               Node
110                               gal    Percent  Type
  
```

```

-----
-----
109 2                               OUTFALL  0.00     1.07     0 01:53     0
110 0.122          0.000
110 3                               STORAGE  9.76     9.76     0 00:45     0.171
111 0.171          0.052
  
```

111
112

 Node Flooding Summary

116
117 No nodes were flooded.

118
119
120

121 Storage Volume Summary
 122 *****
 123
 124

Storage Unit hr:min	CFS	Average Max Volume Occurrence 1000 ft3	Avg Maximum Pcnt Full	Evap Pcnt Loss	Exfil Pcnt Loss	Maximum Volume 1000 ft3	Max Pcnt Full	Time of days
3 01:52	1.14	1.405	3	0	29	15.718	35	0

130
 131
 132 *****
 133 Outfall Loading Summary
 134 *****
 135

Outfall Node	Flow Freq Pcnt	Avg Flow CFS	Max Flow CFS	Total Volume 10^6 gal
2	12.00	0.39	1.07	0.122
System	12.00	0.39	1.07	0.122

145
 146 *****
 147 Link Flow Summary
 148 *****
 149

Link	Type	Maximum Flow CFS	Time of Max Occurrence days hr:min	Maximum Veloc ft/sec	Max/ Full Flow	Max/ Full Depth
1	ORIFICE	1.07	0 01:53			0.00
2	DUMMY	0.00	0 00:00			

158
 159 *****
 160 Conduit Surcharge Summary
 161 *****
 162

163 No conduits were surcharged.

164
 165
 166 Analysis begun on: Fri Jul 8 17:00:44 2022
 167 Analysis ended on: Fri Jul 8 17:00:44 2022
 168 Total elapsed time: < 1 sec

STAGE-DISCHARGE SIZING OF THE WEIRS AND ORIFICES (INLET CONTROL)

Project: _____
Basin ID: _____

STAGE-DISCHARGE CURVE FOR THE OUTLET STRUCTURE

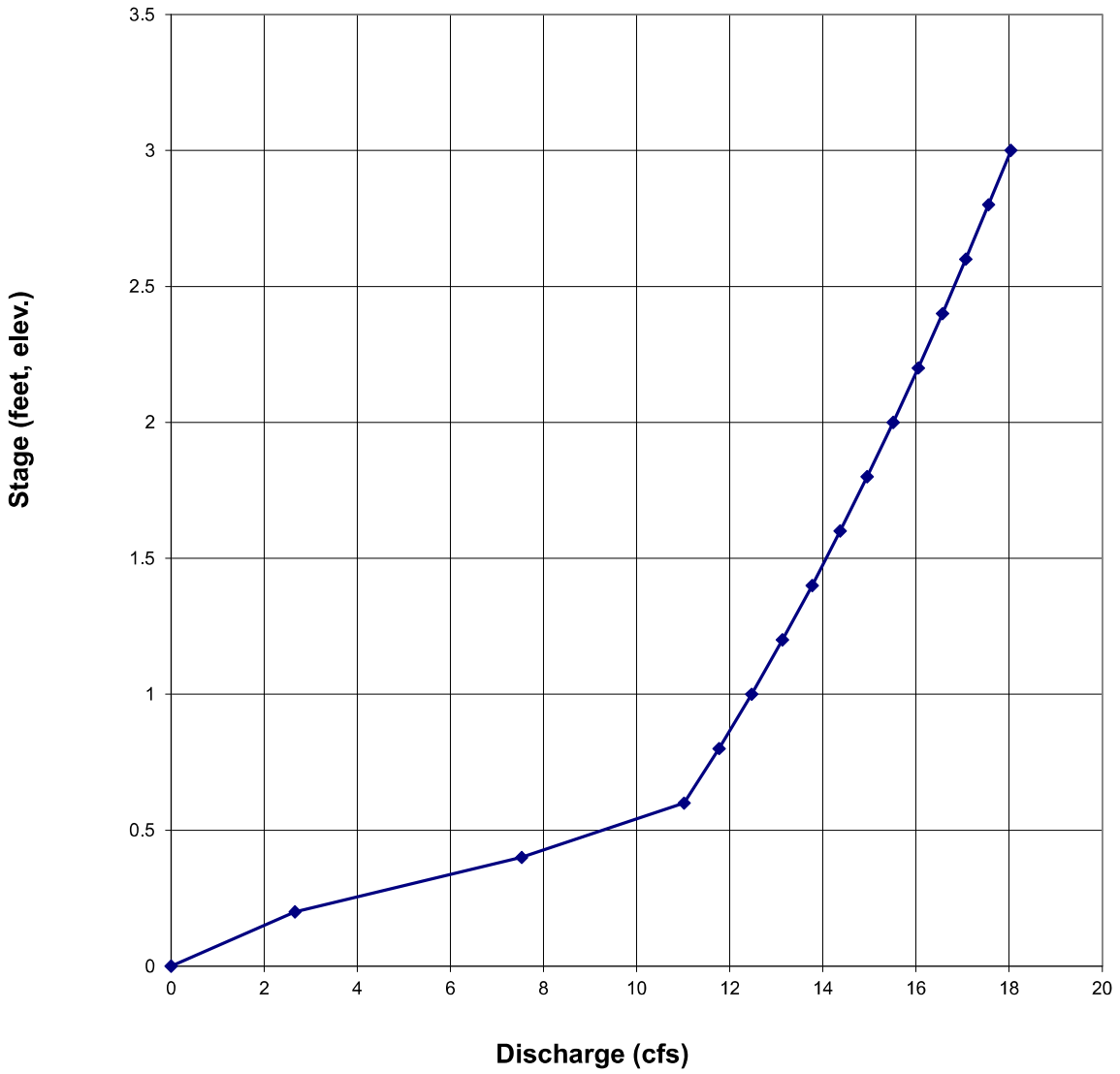

APPENDIX F

Drainage Maps

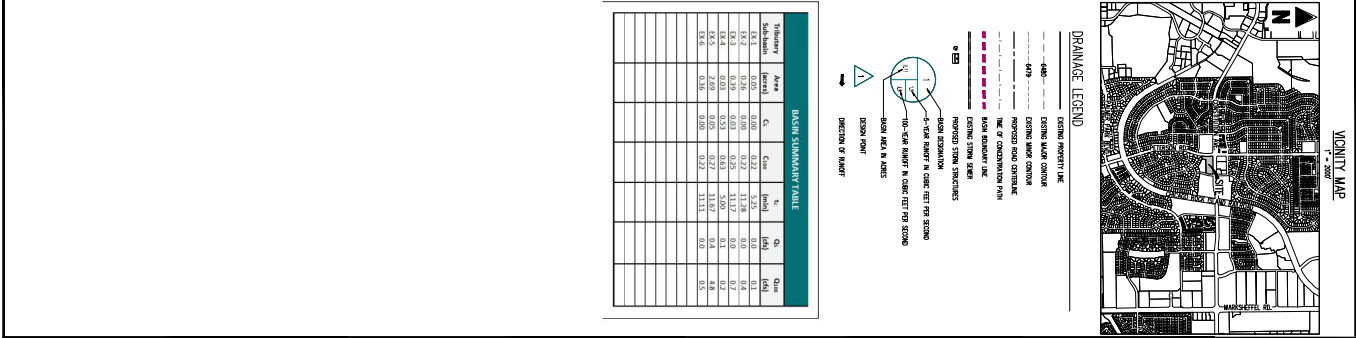
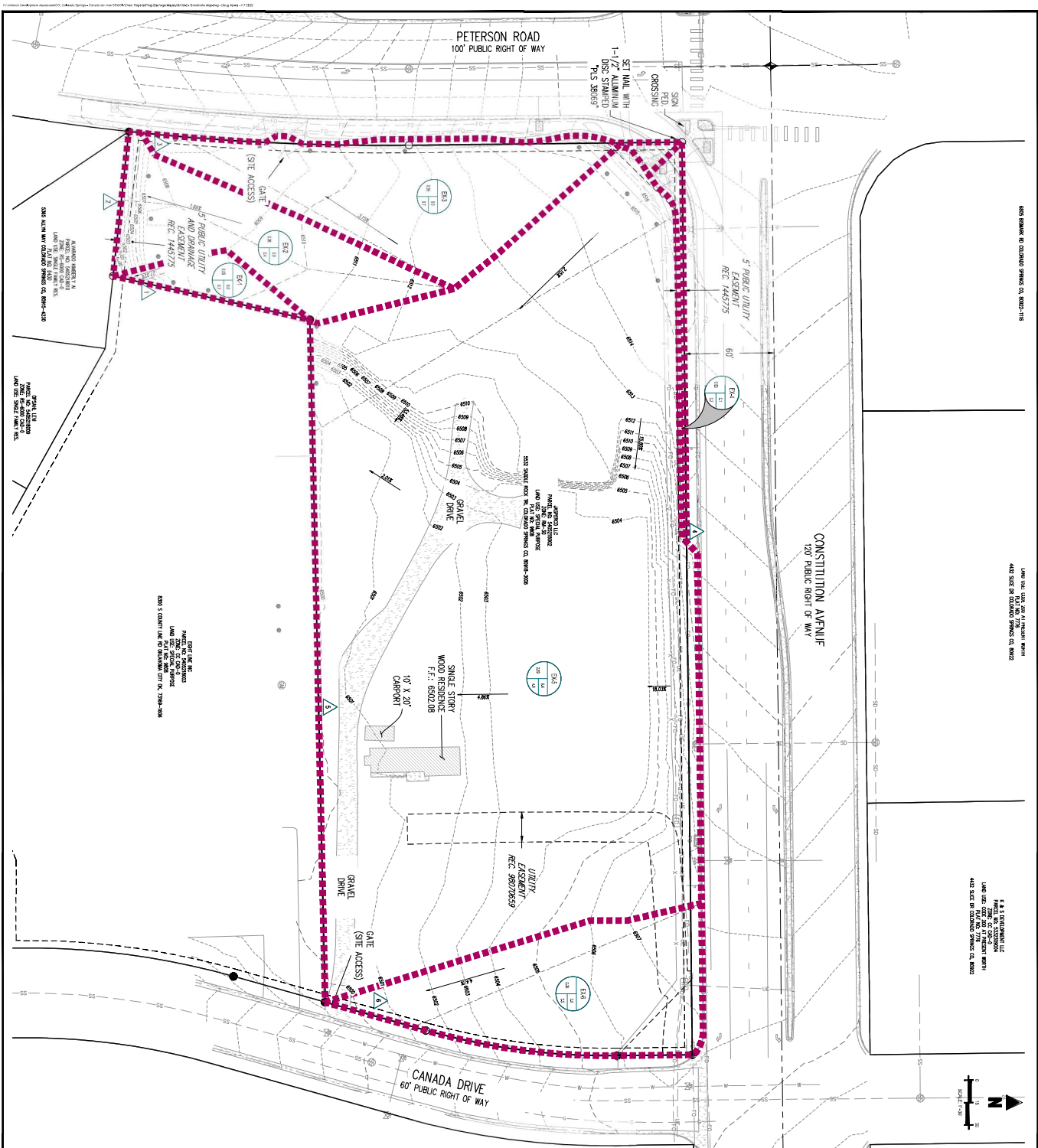

BASELINE SUBDIVISION TABLE

Tract/Block	Area	Acres	Lot	Acres	Lot	Acres	Lot	Acres
1	0.00	0.00	0.00	0.00	0.00	0.00	0.00	0.00
2	0.00	0.00	0.00	0.00	0.00	0.00	0.00	0.00
3	0.00	0.00	0.00	0.00	0.00	0.00	0.00	0.00
4	0.00	0.00	0.00	0.00	0.00	0.00	0.00	0.00
5	0.00	0.00	0.00	0.00	0.00	0.00	0.00	0.00
6	0.00	0.00	0.00	0.00	0.00	0.00	0.00	0.00
7	0.00	0.00	0.00	0.00	0.00	0.00	0.00	0.00
8	0.00	0.00	0.00	0.00	0.00	0.00	0.00	0.00
9	0.00	0.00	0.00	0.00	0.00	0.00	0.00	0.00
10	0.00	0.00	0.00	0.00	0.00	0.00	0.00	0.00
11	0.00	0.00	0.00	0.00	0.00	0.00	0.00	0.00
12	0.00	0.00	0.00	0.00	0.00	0.00	0.00	0.00
13	0.00	0.00	0.00	0.00	0.00	0.00	0.00	0.00
14	0.00	0.00	0.00	0.00	0.00	0.00	0.00	0.00
15	0.00	0.00	0.00	0.00	0.00	0.00	0.00	0.00
16	0.00	0.00	0.00	0.00	0.00	0.00	0.00	0.00
17	0.00	0.00	0.00	0.00	0.00	0.00	0.00	0.00
18	0.00	0.00	0.00	0.00	0.00	0.00	0.00	0.00
19	0.00	0.00	0.00	0.00	0.00	0.00	0.00	0.00
20	0.00	0.00	0.00	0.00	0.00	0.00	0.00	0.00
21	0.00	0.00	0.00	0.00	0.00	0.00	0.00	0.00
22	0.00	0.00	0.00	0.00	0.00	0.00	0.00	0.00
23	0.00	0.00	0.00	0.00	0.00	0.00	0.00	0.00
24	0.00	0.00	0.00	0.00	0.00	0.00	0.00	0.00
25	0.00	0.00	0.00	0.00	0.00	0.00	0.00	0.00
26	0.00	0.00	0.00	0.00	0.00	0.00	0.00	0.00
27	0.00	0.00	0.00	0.00	0.00	0.00	0.00	0.00
28	0.00	0.00	0.00	0.00	0.00	0.00	0.00	0.00
29	0.00	0.00	0.00	0.00	0.00	0.00	0.00	0.00
30	0.00	0.00	0.00	0.00	0.00	0.00	0.00	0.00
31	0.00	0.00	0.00	0.00	0.00	0.00	0.00	0.00
32	0.00	0.00	0.00	0.00	0.00	0.00	0.00	0.00
33	0.00	0.00	0.00	0.00	0.00	0.00	0.00	0.00
34	0.00	0.00	0.00	0.00	0.00	0.00	0.00	0.00
35	0.00	0.00	0.00	0.00	0.00	0.00	0.00	0.00
36	0.00	0.00	0.00	0.00	0.00	0.00	0.00	0.00
37	0.00	0.00	0.00	0.00	0.00	0.00	0.00	0.00
38	0.00	0.00	0.00	0.00	0.00	0.00	0.00	0.00
39	0.00	0.00	0.00	0.00	0.00	0.00	0.00	0.00
40	0.00	0.00	0.00	0.00	0.00	0.00	0.00	0.00
41	0.00	0.00	0.00	0.00	0.00	0.00	0.00	0.00
42	0.00	0.00	0.00	0.00	0.00	0.00	0.00	0.00
43	0.00	0.00	0.00	0.00	0.00	0.00	0.00	0.00
44	0.00	0.00	0.00	0.00	0.00	0.00	0.00	0.00
45	0.00	0.00	0.00	0.00	0.00	0.00	0.00	0.00
46	0.00	0.00	0.00	0.00	0.00	0.00	0.00	0.00
47	0.00	0.00	0.00	0.00	0.00	0.00	0.00	0.00
48	0.00	0.00	0.00	0.00	0.00	0.00	0.00	0.00
49	0.00	0.00	0.00	0.00	0.00	0.00	0.00	0.00
50	0.00	0.00	0.00	0.00	0.00	0.00	0.00	0.00
51	0.00	0.00	0.00	0.00	0.00	0.00	0.00	0.00
52	0.00	0.00	0.00	0.00	0.00	0.00	0.00	0.00
53	0.00	0.00	0.00	0.00	0.00	0.00	0.00	0.00
54	0.00	0.00	0.00	0.00	0.00	0.00	0.00	0.00
55	0.00	0.00	0.00	0.00	0.00	0.00	0.00	0.00
56	0.00	0.00	0.00	0.00	0.00	0.00	0.00	0.00
57	0.00	0.00	0.00	0.00	0.00	0.00	0.00	0.00
58	0.00	0.00	0.00	0.00	0.00	0.00	0.00	0.00
59	0.00	0.00	0.00	0.00	0.00	0.00	0.00	0.00
60	0.00	0.00	0.00	0.00	0.00	0.00	0.00	0.00
61	0.00	0.00	0.00	0.00	0.00	0.00	0.00	0.00
62	0.00	0.00	0.00	0.00	0.00	0.00	0.00	0.00
63	0.00	0.00	0.00	0.00	0.00	0.00	0.00	0.00
64	0.00	0.00	0.00	0.00	0.00	0.00	0.00	0.00
65	0.00	0.00	0.00	0.00	0.00	0.00	0.00	0.00
66	0.00	0.00	0.00	0.00	0.00	0.00	0.00	0.00
67	0.00	0.00	0.00	0.00	0.00	0.00	0.00	0.00
68	0.00	0.00	0.00	0.00	0.00	0.00	0.00	0.00
69	0.00	0.00	0.00	0.00	0.00	0.00	0.00	0.00
70	0.00	0.00	0.00	0.00	0.00	0.00	0.00	0.00
71	0.00	0.00	0.00	0.00	0.00	0.00	0.00	0.00
72	0.00	0.00	0.00	0.00	0.00	0.00	0.00	0.00
73	0.00	0.00	0.00	0.00	0.00	0.00	0.00	0.00
74	0.00	0.00	0.00	0.00	0.00	0.00	0.00	0.00
75	0.00	0.00	0.00	0.00	0.00	0.00	0.00	0.00
76	0.00	0.00	0.00	0.00	0.00	0.00	0.00	0.00
77	0.00	0.00	0.00	0.00	0.00	0.00	0.00	0.00
78	0.00	0.00	0.00	0.00	0.00	0.00	0.00	0.00
79	0.00	0.00	0.00	0.00	0.00	0.00	0.00	0.00
80	0.00	0.00	0.00	0.00	0.00	0.00	0.00	0.00
81	0.00	0.00	0.00	0.00	0.00	0.00	0.00	0.00
82	0.00	0.00	0.00	0.00	0.00	0.00	0.00	0.00
83	0.00	0.00	0.00	0.00	0.00	0.00	0.00	0.00
84	0.00	0.00	0.00	0.00	0.00	0.00	0.00	0.00
85	0.00	0.00	0.00	0.00	0.00	0.00	0.00	0.00
86	0.00	0.00	0.00	0.00	0.00	0.00	0.00	0.00
87	0.00	0.00	0.00	0.00	0.00	0.00	0.00	0.00
88	0.00	0.00	0.00	0.00	0.00	0.00	0.00	0.00
89	0.00	0.00	0.00	0.00	0.00	0.00	0.00	0.00
90	0.00	0.00	0.00	0.00	0.00	0.00	0.00	0.00
91	0.00	0.00	0.00	0.00	0.00	0.00	0.00	0.00
92	0.00	0.00	0.00	0.00	0.00	0.00	0.00	0.00
93	0.00	0.00	0.00	0.00	0.00	0.00	0.00	0.00
94	0.00	0.00	0.00	0.00	0.00	0.00	0.00	0.00
95	0.00	0.00	0.00	0.00	0.00	0.00	0.00	0.00
96	0.00	0.00	0.00	0.00	0.00	0.00	0.00	0.00
97	0.00	0.00	0.00	0.00	0.00	0.00	0.00	0.00
98	0.00	0.00	0.00	0.00	0.00	0.00	0.00	0.00
99	0.00	0.00	0.00	0.00	0.00	0.00	0.00	0.00
100	0.00	0.00	0.00	0.00	0.00	0.00	0.00	0.00

DR-1

**6855 CONSTITUTION AVE. STORAGE SITE
COMMERCIAL DEVELOPMENT
DRAINAGE MAP
FOR JOHNSON DEVELOPMENT ASSOCIATES**

LOT 1 OF THE EIGHT LINE SUBDIVISION
COLORADO SPRINGS, CO 80915

Galloway

5100 S. WINDY CHASE, SUITE 300
COLORADO SPRINGS, CO 80921
303.770.8888
Galloway.com

**PRELIMINARY
NOT FOR BIDDING
NOT FOR CONSTRUCTION**

DATE: 07/26/2022

PROJECT: 6855 CONSTITUTION AVE. STORAGE SITE COMMERCIAL DEVELOPMENT DRAINAGE MAP

DESIGNER: GALLOWAY

CHECKED BY: [Name]

DATE: 07/26/2022

EXISTING DRAINAGE MAP

