



FINAL DRAINAGE REPORT

CONSTITUTION STORAGE DEVELOPMENT

El Paso County, Colorado

PREPARED FOR:
Johnson Development Associates, Inc.
100 Dunbar Street, Suite 400
Spartanburg, SC 29306

PREPARED BY:
Galloway & Company, Inc.
1155 Kelly Johnson Blvd., Suite 305
Colorado Springs, CO 80920

DATE:
July 21, 2023

PCD Filing No.: PPR-2224

ENGINEER'S STATEMENT

The attached drainage plan and report were prepared under my direction and supervision and are correct to the best of my knowledge and belief. Said drainage report has been prepared according to the criteria established by the County for drainage reports and said report is in conformity with the applicable master plan of the drainage basin. I accept responsibility for any liability caused by any negligent acts, errors or omissions on my part in preparing this report.

Brady A. Shyrock, PE #38164
For and on behalf of Galloway & Company, Inc.

07/21/2023
Date



DEVELOPER'S CERTIFICATION

I, The developer, have read and will comply with all of the requirements specified in this drainage report and plan.

By: _____

7/21/2023
Date

Address: Johnson Development Associates, Inc.
101 N. Pacific Coast Hwy, Suite 308
El Segundo, CA 90245

EL PASO COUNTY CERTIFICATION

Filed in accordance with the requirements of the Drainage Criteria Manual, Volumes 1 and 2, El Paso County Engineering Criteria Manual and Land Development Code as amended.

Joshua Palmer, P.E.
Interim County Engineer

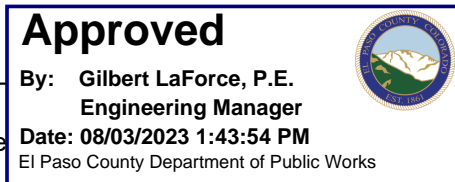

Date

Conditions:

TABLE OF CONTENTS

I.	Purpose	4
II.	General Description	4
III.	Drainage Criteria	4
IV.	Existing Drainage Conditions	5
V.	Four Step Process	6
	1. Employ Runoff Reduction Practices.....	6
	2. Stabilize Channels.....	6
	3. Provide Water Quality Capture Volume (WQCV)	6
	4. Consider Need for Industrial and Commercial BMPs	7
VI.	Proposed Drainage Conditions	7
VII.	Storm Sewer System.....	9
VIII.	Proposed Water Quality Detention Ponds	9
IX.	Proposed Channel Improvements.....	10
X.	Maintenance	10
XI.	Wetlands Mitigation	10
XII.	Floodplain Statement	10
XIII.	Drainage Fees & Maintenance.....	10
XIV.	Conclusion.....	11
XV.	References	11

Appendices:

- A. Exhibits and Figures
- B. Hydrologic Computations
- C. Hydraulic Computations
- D. Water Quality Computations
- E. Drainage Maps
- F. PCM Plans

I. Purpose

The purpose of this Final Drainage Report is to identify on and offsite drainage patterns, locate and identify tributary or downstream drainage features and facilities that impact the site, and to identify which types of drainage facilities will be needed and where they will be located. This report will remain in general compliance with the approved FDR prepared by Costin Engineering Company, dated February 2, 1983.

II. General Description

The project is a self-storage commercial development located in the Cimarron Hills area of El Paso County, Colorado. The site is located in a portion of Section 05, Township 14 South, Range 65 West of the 6th Principal Meridian, County of El Paso, State of Colorado. The subject property is bounded by Constitution Avenue to the north, Canada Drive to the east, Peterson Road to the west, and existing Northcrest Filing No. 3 residential development to the south. A Vicinity Map is included in **Appendix A**.

This final drainage report is the basis for the drainage facility design in conformance with the previously approved FDR for the site prepared by Costin Engineering Company, "*Amendment Number 1, Final Drainage Study, Cimarron Northcrest Filing No. 3*", Costin Engineering Company, February 1983 (**FDR**). The site consists of approximately 3.716 acres and includes 929 storage units.

The existing soil types within the proposed site as determined by the NRCS Web Soil Survey for El Paso County Area consist of Truckton Sandy Loam (hydrologic soil group A). See the soils map included in **Appendix A**.

III. Drainage Criteria

Hydrology calculations were performed using the City of Colorado Springs/El Paso County Drainage Criteria Manual, as revised in November 1991 and October 1994 with County adopted Chapter 6 and Section 3.2.1 of Chapter 13 of the City of Colorado Springs/El Paso County Drainage Criteria Manual as revised in May 2014.

The drainage calculations were based on the criteria manual Figure 6-5 and IDF equations to determine the intensity and are listed in Table 1 below.

Table 1 - Precipitation Data

Return Period	One Hour Depth (in.)	Intensity (in/hr)
5-year	1.50	5.17
100-year	2.52	8.68

The rational method was used to calculate peak flows as the tributary areas are less than 100 acres. The rational method has been proven to be accurate for basins of this size and is based on the following formula:

$$Q = CIA$$

Where:

Q = Peak Discharge (cfs)

C = Runoff Coefficient

I = Runoff intensity (inches/hour)

A = Drainage area (acres)

The runoff coefficients are calculated based on land use, percent imperviousness, and design storm for each basin, as shown in the drainage criteria manual (Table 6-6). Composite percent impervious and C values were calculated using the residential, streets, roofs, and lawns coefficients found in Table 6-6 of the manual.

The 100-year event was used as the major storm event. The 5-year event was used as the minor event. The UD-Inlets v5.01 spreadsheet was utilized for the sizing of the proposed sump inlets.

The UD-Detention v4.04 spreadsheet was utilized for the design of the proposed on-site Full Spectrum Detention Pond.

IV. Existing Drainage Conditions

The site lies within the existing Sand Creek drainage basin (see Reference Map). Based on this report, existing topography, and proposed future developments, no off-site basins will impact the site. Stormwater from this site generally drains to the southeast and southwest and will be routed to a single (1) private full spectrum detention facility designated as FSD-1 which has been sized to accommodate the developed flows from this site. The rational method was used to analyze the individual basins within the site because their size permits it.

The property presently discharges via sheet flow along the southern property line onto the adjacent Eight Line Inc. property and Alvarado property. Portions of the site along the eastern and western property lines also drain to the adjacent right-of-ways.

While the **FDR** shows a total of 26 basins that were analyzed as part of the overall Northcrest Filing No. 3 development, for the purposes of this report, only one (1) of the Basins within the FDR will be used for analysis. This Basin, C-4 (6.3 AC, $Q_5 = 7.0$ cfs, $Q_{100} = 18.30$ cfs) is located at the northwest corner of the approved FDR study area and drains through properties to the south to Allyn Way.

The **FDR** also establishes that runoff from Basin C-4 will be conveyed via curb and gutter to an existing detention facility south of the site along Piros Drive. This existing detention facility will no longer be utilized for water quality or detention for the project site, but the existing street flow drainage pattern will be maintained. As a result, the proposed private FSD-1 pond will outlet at grade to the curb in Canada Drive. There is no storm sewer infrastructure existing in Canada Drive.

For a more in-depth analysis of existing tributary conditions as it pertains to this phase of development, an existing basin map has been prepared. The existing map can be found in **Appendix E** and basins are described below. The site has been divided into six (6) sub-basins to better show where runoff flows in the current conditions.

Basin EX-1 (0.05 AC, $Q_5 = 0.0$ cfs, $Q_{100} = 0.1$ cfs): This basin encompasses a portion of the southwest of the site in the existing condition. This basin consists of un-developed land. Runoff from this basin will sheet flow to the south before outfalling onto the adjacent Eight Line Inc. property. (**DP 1**).

Basin EX-2 (0.26 AC, $Q_5 = 0.0$ cfs, $Q_{100} = 0.4$ cfs): This basin encompasses the southwest portion of the site in the existing condition. This basin consists of un-developed land. Runoff from this basin will sheet flow to the south before outfalling onto the adjacent Alvarado property. **(DP 2)**.

Basin EX-3 (0.39 AC, $Q_5 = 0.0$ cfs, $Q_{100} = 0.7$ cfs): This basin encompasses the western portion of the site in the existing condition, as well as a portion of the Peterson Road right-of-way. This basin consists of un-developed land and a portion of existing sidewalk. Runoff from this basin will sheet flow to the southwest before outfalling into Peterson Road. **(DP 3)**.

Basin EX-4 (0.03 AC, $Q_5 = 0.1$ cfs, $Q_{100} = 0.2$ cfs): This basin encompasses a portion of the northwest of the site in the existing condition. This basin consists mostly of existing sidewalk. Runoff from this basin will sheet flow to the north before outfalling into Constitution Avenue. **(DP 4)**.

Basin EX-5 (2.69 AC, $Q_5 = 0.4$ cfs, $Q_{100} = 4.8$ cfs): This basin encompasses the majority of the site in the existing condition, as well as a portion of Constitution Avenue right-of-way that is currently undeveloped. This basin consists of un-developed land, access drive, and a single-family home. Runoff from this basin will sheet flow to the south before outfalling onto the adjacent Eight Line Inc. property. **(DP 5)**.

Basin EX-6 (0.36 AC, $Q_5 = 0.0$ cfs, $Q_{100} = 0.5$ cfs): This basin encompasses the eastern portion of the site in the existing condition, as well as a portion of Constitution Avenue right-of-way that is currently undeveloped. This basin consists of un-developed land. Runoff from this basin will sheet flow to the southeast before outfalling into Canada Drive. **(DP 6)**.

V. Four Step Process

The Four Step Process is used to minimize the adverse impacts of urbanization and is a vital component of developing a balanced, sustainable project. Below identifies the approach to the four-step process:

1. Employ Runoff Reduction Practices

This step uses low impact development (LID) practices to reduce runoff at the source. Generally, rather than creating point discharges that are directly connected to impervious areas runoff is routed through pervious areas to promote infiltration. The Impervious Reduction Factor (IRF) method was used, and calculations can be found in **Appendix D**. For the majority of the site this is not practical, however portions of the site do drain through landscaped swales prior to entering the storm sewer system.

2. Stabilize Channels

This step implements stabilization to channels to accommodate developed flows while protecting infrastructure and controlling sediment loading from erosion in the drainageways. This project does not discharge to a channel. Flows are detained onsite to control release rates from the site down to existing rates and not adversely impact downstream facilities. The site is designed to release at or below the existing release rate for the site and will not negatively impact the downstream infrastructure.

3. Provide Water Quality Capture Volume (WQCV)

This step utilizes formalized water quality capture volume to slow the release of runoff from the site. The EURV volume will release in 79 hours, while the WQCV will release in no less than 40 hours. An on-site Full Spectrum Detention Pond will provide water quality treatment for the majority of the

developed areas, prior to the runoff being released into existing curb flowlines at Canada Dr. Refer to WQCV Plan in **Appendix E**.

4. Consider Need for Industrial and Commercial BMPs

As this project is a commercial development, roof drains connecting directly to proposed water quality and detention facility, surface flows being routed to inlets that capture developed runoff and direct flows to proposed water quality and detention facility. Stockpile and concrete washout BMPs will be implemented onsite. At the Contractor's discretion, additional specialized BMPs which would be associated with an industrial or commercial site may be implemented.

VI. Proposed Drainage Conditions

The proposed development lies completely within the Sand Creek Drainage Basin and consists of eleven (11) sub-basins. Site runoff will be collected via sheet flows, roof drains, inlets & pipes and diverted to the one (1) proposed full spectrum detention pond (FSD-1). All necessary calculations can be found within the appendices of this report.

According to the **FDR**, the proposed project site lies within Basin C-4 (6.3 AC, $Q_5 = 7.0$ cfs, $Q_{100} = 18.30$ cfs) is located at the northwest corner of the approved FDR study area. The property presently discharges via sheet flow along the southern property line onto the adjacent Eight Line Inc. property.

The site will provide one (1) private Full Spectrum Detention Pond (FSD). Pond FSD-1 will discharge treated runoff at historic rates directly into the existing curb flowline at Canada Drive, as there is not adjacent storm sewer infrastructure.

As has been mentioned previously, the site is proposed to have a land use of commercial self-storage. The site will consist of 929 storage units along with associated parking, drive aisles, RV storage, detention pond, and landscaping areas.

Basin PR-1 (0.22 AC, $Q_5 = 0.0$ cfs, $Q_{100} = 0.4$ cfs): Located at the southwestern corner of the site, Basin PR-1 contains the proposed landscaping improvements immediately adjacent to the existing residential development (Northcrest Filing No. 3). Runoff from this basin will sheet flow to the existing southern boundary into the Alvarado property as it does in the existing condition (Basin EX-2) (**DP 1**). Due to layout and grading limitations, runoff from this basin is not receiving water quality treatment per exclusions in ECM Section I.7.1.C.1.a, reference Section VIII of this report for additional information.

Basin PR-2A (0.05 AC, $Q_5 = 0.0$ cfs, $Q_{100} = 0.1$ cfs): Located on the western boundary of the site, this basin consists of landscaping and sidewalk adjacent to the property line. Runoff from this basin will sheet flow to existing curb and gutter in Peterson Rd. Flows will then be routed, via the existing curb & gutter at the southwestern corner of the project site (**DP 2A**). Due to layout and grading limitations, runoff from this basin is not receiving water quality treatment per exclusions in ECM Section I.7.1.C.1.a, reference Section VIII of this report for additional information.

Basin PR-2B (0.01 AC, $Q_5 = 0.0$ cfs, $Q_{100} = 0.1$ cfs): Located on the northwestern corner of the site, this basin consists of sidewalk and landscaping. Runoff from this basin will sheet flow to existing curb and gutter at Peterson Rd. Flows will then be routed, via existing curb & gutter at the northwestern corner of the project site (**DP 2B**). Due to layout and grading limitations, runoff from this basin is not receiving water quality treatment per exclusions in ECM Section I.7.1.C.1.a, reference Section VIII of this report for additional information.

Basin PR-3 (0.22 AC, $Q_5 = 0.2$ cfs, $Q_{100} = 0.7$ cfs): Located on the northern boundary of the site, this basin consists of sidewalk and landscaping, as well as offsite areas within the Constitution right-of-way being developed. Runoff from this basin will sheet flow to existing curb and gutter in Constitution Ave. Flows will then be routed, via existing curb & gutter downstream to the northeastern corner of the project site (**DP 3**). Due to layout and grading limitations, runoff from this basin is not receiving water quality treatment per exclusions in ECM Section I.7.1.C.1.a, reference Section VIII of this report for additional information.

Basin PR-4 (0.25 AC, $Q_5 = 0.2$ cfs, $Q_{100} = 0.7$ cfs): Located on the eastern boundary of the site, this basin consists of driveway and landscaping. Runoff from this basin will sheet flow from the driveway to proposed curb and gutter at the driveway and Canada Dr. Flows will then be routed, via curb & gutter downstream to the existing curb & gutter at the southeastern corner of the project site (**DP 4**). Due to layout and grading limitations, runoff from this basin is not receiving water quality treatment per exclusions in ECM Section I.7.1.C.1.a, reference Section VIII of this report for additional information.

Basin PR-5 (1.32 AC, $Q_5 = 3.9$ cfs, $Q_{100} = 9.0$ cfs): Located on the northcentral portion of the site, this basin consists entirely of the proposed two-story building. Flows will be captured by roof drains and routed, via pipe (**DP 5**), to the proposed (private) full spectrum detention (FSD-1) located at the northeast corner of the site (**DP 10**).

Basin PR-6 (0.92 AC, $Q_5 = 1.2$ cfs, $Q_{100} = 3.3$ cfs): Located on the central portion of the site, west and south of Basin PR-5. This basin consists of landscaping and driveway. Runoff from this basin will sheet flow from the driveway to the proposed curb and gutter to the proposed (private) 10' Colorado Springs D-10-R inlet (**DP 6A**) where flows will be routed, via pipe, to the proposed (private) full spectrum detention (FSD-1) located at the northeast corner of the site (**DP 10**). Emergency overflows (events exceeding the 100-year design storm) will be routed downstream via proposed curb and gutter to Canada Drive.

Basin PR-7 (0.19 AC, $Q_5 = 0.6$ cfs, $Q_{100} = 1.3$ cfs): Located on the northcentral portion of the site east of Basin PR-5, this basin consists of landscaping, and RV storage. Runoff from this basin will sheet flow to the edge of the proposed RV storage area to a proposed (private) 6' Colorado Springs D-10-R inlet in sump condition (**DP 7**), where flows will be routed, via pipe, to the proposed (private) full spectrum detention (FSD-1) located at the northeast corner of the site (**DP 10**). Emergency overflows (events exceeding the 100-year design storm) will be routed downstream via proposed curb and gutter to Canada Drive.

Basin PR-8 (0.13 AC, $Q_5 = 0.0$ cfs, $Q_{100} = 0.2$ cfs): Located on the northern portion of the site, this basin consists entirely of landscaped area and swale north of the building. Runoff from this basin will sheet flow to the proposed swale to the proposed (private) CDOT Type C inlet (**DP 8**) where flows will be routed, via pipe, to the proposed (private) full spectrum detention (FSD-1) located at the northeast corner of the site (**DP 10**). Emergency overflows (events exceeding the 100-year design storm) will be routed downstream via proposed curb and gutter to Canada Drive.

Basin PR-9 (0.17 AC, $Q_5 = 0.5$ cfs, $Q_{100} = 0.9$ cfs): Located in the eastern portion of the site, this basin consists of drive aisle and parking. Runoff from this basin will sheet flow to a proposed (private) 6' Colorado Springs D-10-R inlet in on-grade conditions, located on the south side of the access drive adjacent to the eastern most parking stalls (**DP 9**) where flows will be routed, via pipe, to the proposed (private) full spectrum detention (FSD-1) located at the northeast corner of the site (**DP 10**). Emergency overflows (events exceeding the 100-year design storm) will be routed downstream via proposed curb and gutter to Canada Drive.

Basin PR-10 (0.31 AC, $Q_5 = 0.0$ cfs, $Q_{100} = 0.6$ cfs): Located at the northeastern corner of the site, Basin PR-8 contains the entirety of the proposed (private) full spectrum detention (FSD-1) and adjacent landscaped area. Runoff from this basin will sheet flow directly to the (private) full spectrum detention (FSD-1) (**DP 10**).

VII. Storm Sewer System

All development is anticipated to be urban and will include storm sewer & street inlets. Storm sewers collect storm water runoff and convey the water to the water quality facility prior to discharging. Storm sewer systems will be designed to the 100-year storm and checked with the 5-year storm. Inlets will be placed at sump areas and locations where street flow is larger than street capacity. UDFCD Inlet spreadsheet has been used to determine the size of all sump inlets. Emergency overflow conditions discussed above will only be activated in storm events exceeding the 100-year storm event.

There will be a proposed storm system within the site. The storm sewer system will discharge storm water into the proposed private full spectrum detention facility (FSD-1). The proposed system will consist of HDPE pipe, CDOT Type C inlets, Colorado Springs D-10-R inlets, Nyloplast Drain Basins, and storm sewer manholes. Inlet sizing and capacity calculations can be found in **Appendix D**, along with preliminary storm sewer sizing.

Additionally, there are two (2) proposed drainage swales that run along the north and west side of the proposed building, respectively within sub-basins PR-8 and PR-6. The swales were analyzed using the Bentley software FlowMaster to properly size a triangular channel to convey the 100-year flows from the basins to FSD-1, while providing 1.0-ft of freeboard. The sizing calculations can be found in **Appendix D**.

VIII. Proposed Water Quality Detention Ponds

One (1) Full Spectrum Detention Pond (FSD-1) will be provided for the proposed site. The proposed pond will be privately owned and maintained by Johnson Development Associates Inc., once established. This detention pond is proposed to be full spectrum and will provide water quality and detention. Flows will be routed into the pond with the proposed (private) storm sewer system and release onto proposed forebays into the pond. The WQCV release will be controlled by an orifice plate within the outlet structure. The release rates for the WQCV and EURV will be 40-hours and 79-hours, respectively, and will pond to depths of 6500.98 and 6502.14. Flows exceeding the WQCV will be controlled by orifices and a modified Type C Outlet Structure and will be designed to release at or below the pre-development flow rate. A proposed outlet structure has been designed with this report. See **Appendix D** for calculations. Basins PR-5 through PR-10 drain to FSD-1, totaling 3.03 acres and 81% of the project site.

Note: The approved Northcrest Filing No. 3 FDR designed the area of the project site to drain to a detention facility south of the site via curb and gutter. While this existing drainage facility is no longer being utilized for water quality or detention, the existing drainage pattern using curb and gutter must be maintained as there is no existing storm sewer system in Canada Dr.

Per ECM Section I.7.1.C.1.a, 20% of the site may free release offsite, not to exceed 1 acre. Because the proposed private FSD-1 pond must outlet at grade to the curb and gutter, there are significant grading limitations to the site. Because of this, Basins PR-1, PR-2A, PR-2B, PR-3 and PR-4 free release off-site, totaling 0.75 acres and 19% of the site area. These basins also generally reflect the existing drainage patterns for the perimeter of the site. Since these basins are 19% of the site and do not exceed 1 acre, the project site complies with ECM Section I.7.1.C.1.a.

FSD-1: Located at the northeastern corner of the site, just west of existing Canada Dr. This pond will discharge to the existing western curb line within Canada Dr. The required volume WQCV and EURV are 0.074 Ac-Ft & 0.213 Ac-Ft, respectively. The total required detention basin volume is 0.416 Ac-Ft. See **Appendix D** for volume calculations.

IX. Proposed Channel Improvements

There are no proposed channel improvements as part of this report.

X. Maintenance

After completion of construction, the drainage facility (FSD-1) will be privately owned and maintained by Johnson Development Associates, Inc.

XI. Wetlands Mitigation

There are no existing wetlands within the project site.

XII. Floodplain Statement

No portion of the project site lies with the designated Flood Zone as defined by the FIRM Map number 08041C0752G effective December 7, 2018. A copy of the FIRM Panel is included in **Appendix A**.

XIII. Drainage Fees & Maintenance

Drainage fees do not apply for Site Development Plans and are therefore not applicable to this project.

Below is a cost estimate for the improvements proposed with this filing.

Item	Quantity	Unit	Unit Cost	Cost
Storm Drain Improvements (Private)				
CDOT Type C Inlet (Private)	1	EA	\$ 5,611.00	\$ 5,611.00
6' Type D-10 R Inlet (Private)	2	EA	\$ 8,715.00	\$ 17,430.00
10' Type D-10 R Inlet (Private)	1	EA	\$ 9,224.00	\$ 9,224.00
Storm Sewer Manhole, Slab Base	3	EA	\$ 7,734.00	\$ 23,202.00
18" Storm Drain - RCP (Private)	355	LF	\$ 76.00	\$ 26,980.00
18" Storm Drain - HDPE (Private)	475	LF	\$ 60.00	\$ 28,500.00
18" FES	1	EA	\$ 420.00	\$ 420.00
Subtotal				\$ 111,367.00
WQCV Detention Ponds (Private)				
Pond (FSD-1)	1	EA	\$ 45,000.00	\$ 45,000.00
Subtotal				\$ 45,000.00
Total				\$ 156,367.00
Contingency			10%	\$ 15,636.70
Grand Total				\$ 172,003.70

XIV. Conclusion

The Constitution Storage commercial development lies within the Sand Creek Drainage Basin. Water quality for the site is provided in a single on-site, private, Full Spectrum Detention Pond; FSD-1. All drainage facilities within this report were sized according to the El Paso County Drainage Criteria Manuals. The private full spectrum detention facility (FSD-1) will be maintained by Johnson Development Associates, Inc. The Constitution Storage development will not adversely impact any downstream facilities.

XV. References

1. *El Paso County Drainage Criteria Manual*, 1990.
2. *Drainage Criteria Manual, Volume 2*, City of Colorado Springs, 2002.
3. *El Paso County Drainage Criteria Manual Update*, 2015.
4. *El Paso County Engineering Criteria Manual*, 2020.
5. *Urban Storm Drainage Criteria Manual*, Urban Drainage and Flood Control District, January 2016 (with current revisions).
6. *Amendment Number 1, Final Drainage Study, Cimarron Northcrest Filing No. 3*", Costin Engineering Company, February 1983.

APPENDIX A

Exhibits and Figures

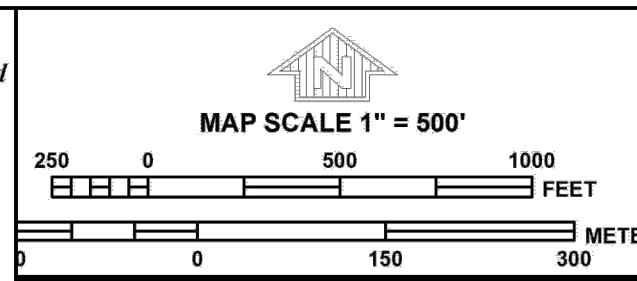
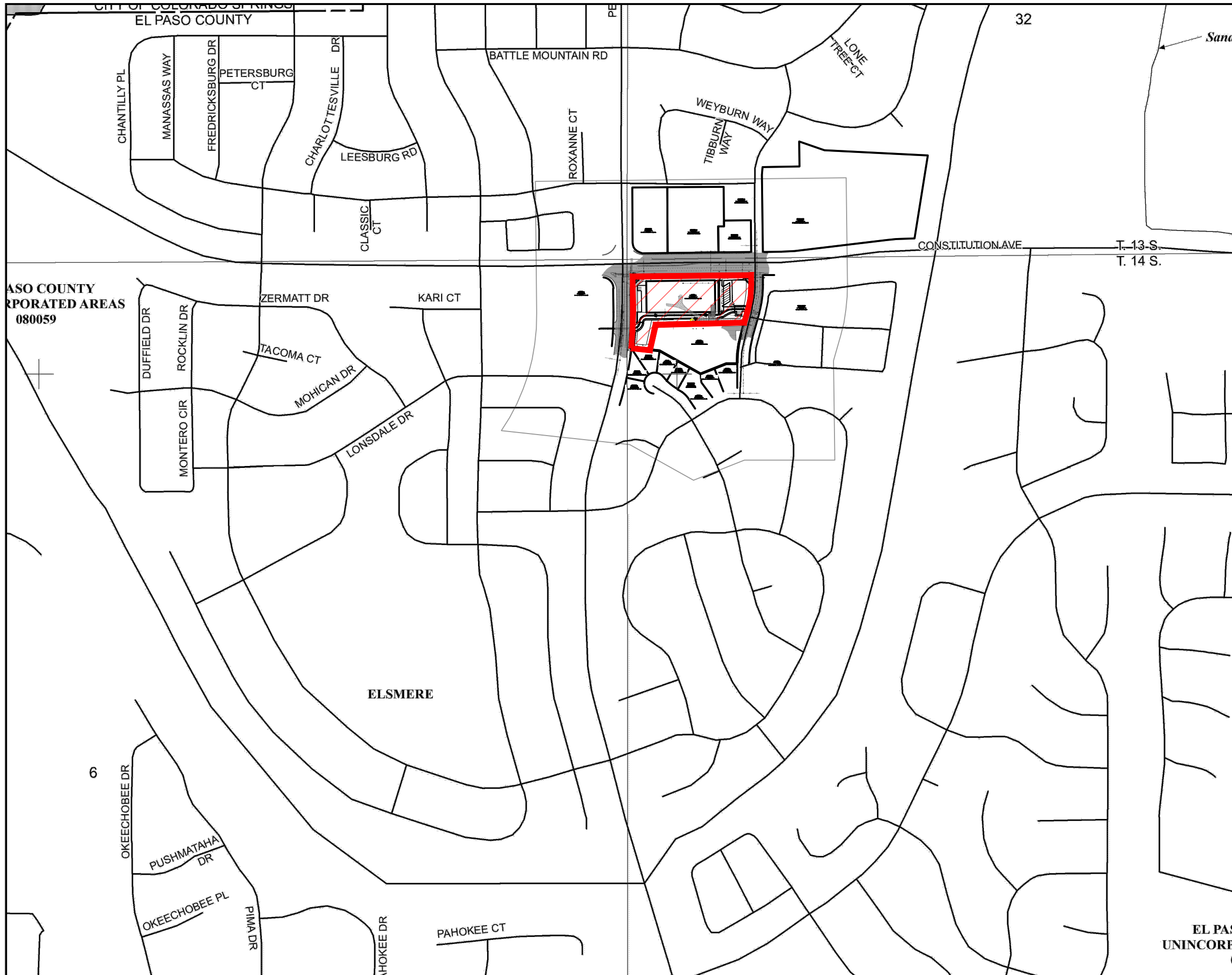

PANEL 0752G

FIRM
FLOOD INSURANCE RATE MAP
EL PASO COUNTY,
COLORADO
AND INCORPORATED AREAS

PANEL 752 OF 1300
 (SEE MAP INDEX FOR FIRM PANEL LAYOUT)

CONTAINS:

COMMUNITY	NUMBER	PANEL	SUFFIX
COLORADO SPRINGS, CITY OF	080060	0752	G
EL PASO COUNTY	080059	0752	G

Notice: This map was reissued on 05/15/2020 to make a correction. This version replaces any previous versions. See the Notice-to-User Letter that accompanied this correction for details.

Notice to User: The Map Number shown below should be used when placing map orders; the Community Number shown above should be used on insurance applications for the subject community.

MAP NUMBER
08041C0752G

MAP REVISED
DECEMBER 7, 2018

Federal Emergency Management Agency



EL PASO COUNTY UNINCORPORATED AREAS 080059

This is an official FIRMette showing a portion of the above-referenced flood map created from the MSC FIRMette Web tool. This map does not reflect changes or amendments which may have been made subsequent to the date on the title block. For additional information about how to make sure the map is current, please see the Flood Hazard Mapping Updates Overview Fact Sheet available on the FEMA Flood Map Service Center home page at <https://msc.fema.gov>.

El Paso County Area, Colorado

97—Truckton sandy loam, 3 to 9 percent slopes

Map Unit Setting

National map unit symbol: 2x0j2

Elevation: 5,300 to 6,850 feet

Mean annual precipitation: 14 to 19 inches

Mean annual air temperature: 48 to 52 degrees F

Frost-free period: 85 to 155 days

Farmland classification: Not prime farmland

Map Unit Composition

Truckton and similar soils: 85 percent

Minor components: 15 percent

Estimates are based on observations, descriptions, and transects of the mapunit.

Description of Truckton

Setting

Landform: Interfluves, hillslopes

Landform position (two-dimensional): Backslope

Landform position (three-dimensional): Side slope

Down-slope shape: Linear

Across-slope shape: Linear

Parent material: Re-worked alluvium derived from arkose

Typical profile

A - 0 to 4 inches: sandy loam

Bt1 - 4 to 12 inches: sandy loam

Bt2 - 12 to 19 inches: sandy loam

C - 19 to 80 inches: sandy loam

Properties and qualities

Slope: 3 to 9 percent

Depth to restrictive feature: More than 80 inches

Drainage class: Well drained

Runoff class: Low

Capacity of the most limiting layer to transmit water (Ksat): High
(2.00 to 6.00 in/hr)

Depth to water table: More than 80 inches

Frequency of flooding: None

Frequency of ponding: None

Calcium carbonate, maximum content: 1 percent

Maximum salinity: Nonsaline (0.1 to 1.9 mmhos/cm)

Available water supply, 0 to 60 inches: Moderate (about 6.6 inches)

Interpretive groups

Land capability classification (irrigated): 6e

Land capability classification (nonirrigated): 6e

Hydrologic Soil Group: A
Ecological site: R049XB210CO - Sandy Foothill
Hydric soil rating: No

Minor Components

Blakeland

Percent of map unit: 8 percent
Landform: Interfluves, hillslopes
Landform position (two-dimensional): Summit, shoulder, backslope
Landform position (three-dimensional): Side slope, crest
Down-slope shape: Convex, linear
Across-slope shape: Convex, linear
Ecological site: R049XB210CO - Sandy Foothill
Hydric soil rating: No

Bresser

Percent of map unit: 7 percent
Landform: Interfluves, low hills
Landform position (two-dimensional): Footslope, toeslope
Landform position (three-dimensional): Base slope
Down-slope shape: Concave, linear
Across-slope shape: Concave, linear
Ecological site: R049XB210CO - Sandy Foothill
Hydric soil rating: No

Data Source Information

Soil Survey Area: El Paso County Area, Colorado
Survey Area Data: Version 19, Aug 31, 2021

Soil Map—El Paso County Area, Colorado

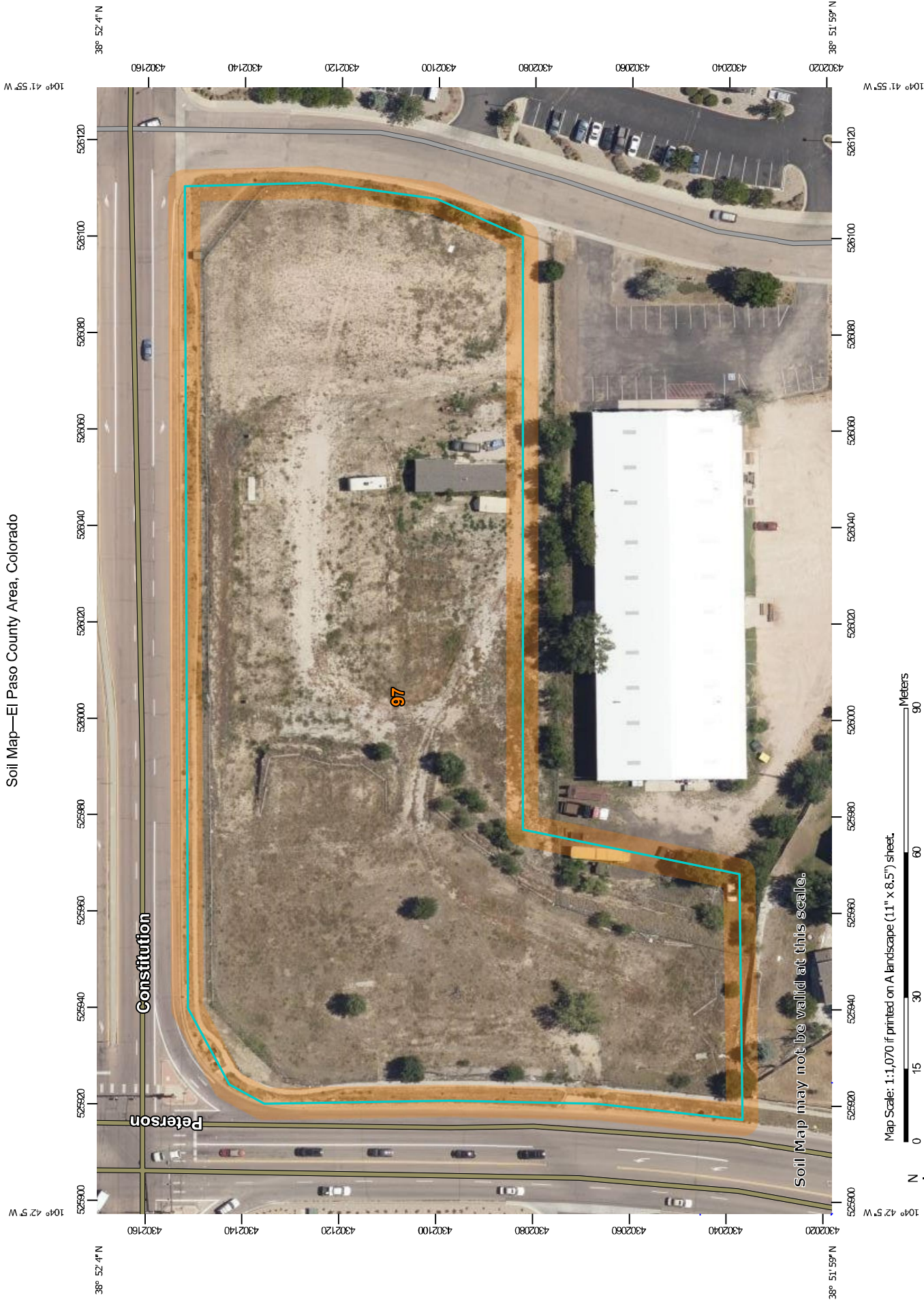





































Map Scale: 1:1,070 if printed on A landscape (11" x 8.5") sheet.



Map projection: Web Mercator Corner coordinates: WGS84 Edge tics: UTM Zone 13N WGS84

MAP LEGEND

-  Area of Interest (AOI)
- Soils**
-  Soil Map Unit Polygons
-  Soil Map Unit Lines
-  Soil Map Unit Points
- Special Point Features**
-  Blowout
-  Borrow Pit
-  Clay Spot
-  Closed Depression
-  Gravel Pit
-  Gravelly Spot
-  Landfill
-  Lava Flow
-  Marsh or swamp
-  Mine or Quarry
-  Miscellaneous Water
-  Perennial Water
-  Rock Outcrop
-  Saline Spot
-  Sandy Spot
-  Severely Eroded Spot
-  Sinkhole
-  Slide or Slip
-  Sodic Spot
-  Spoil Area
-  Stony Spot
-  Very Stony Spot
-  Wet Spot
-  Other
-  Special Line Features
- Water Features**
-  Streams and Canals
- Transportation**
-  Rails
-  Interstate Highways
-  US Routes
-  Major Roads
-  Local Roads
- Background**
-  Aerial Photography

MAP INFORMATION

The soil surveys that comprise your AOI were mapped at 1:24,000.

Warning: Soil Map may not be valid at this scale.

Enlargement of maps beyond the scale of mapping can cause misunderstanding of the detail of mapping and accuracy of soil line placement. The maps do not show the small areas of contrasting soils that could have been shown at a more detailed scale.

Please rely on the bar scale on each map sheet for map measurements.

Source of Map: Natural Resources Conservation Service
 Web Soil Survey URL:
 Coordinate System: Web Mercator (EPSG:3857)

Maps from the Web Soil Survey are based on the Web Mercator projection, which preserves direction and shape but distorts distance and area. A projection that preserves area, such as the Albers equal-area conic projection, should be used if more accurate calculations of distance or area are required.

This product is generated from the USDA-NRCS certified data as of the version date(s) listed below.

Soil Survey Area: El Paso County Area, Colorado
 Survey Area Data: Version 19, Aug 31, 2021

Soil map units are labeled (as space allows) for map scales 1:50,000 or larger.

Date(s) aerial images were photographed: Aug 19, 2018—Sep 23, 2018

The orthophoto or other base map on which the soil lines were compiled and digitized probably differs from the background imagery displayed on these maps. As a result, some minor shifting of map unit boundaries may be evident.

Map Unit Legend

Map Unit Symbol	Map Unit Name	Acres in AOI	Percent of AOI
97	Truckton sandy loam, 3 to 9 percent slopes	3.8	100.0%
Totals for Area of Interest		3.8	100.0%

APPENDIX B

Hydrologic Computations

COMPOSITE % IMPERVIOUS CALCULATIONS

Existing Conditions

Subdivision: _____
 Location: CO, Colorado Springs

Project Name: Constitution Storage
 Project No.: JDA000002
 Calculated By: DDJ
 Checked By: BS
 Date: 7/8/22

Basin ID	Total Area (ac)	Paved Roads			Lawns			Roofs			Basins Total Weighted % Imp.
		% Imp.	Area (ac)	Weighted % Imp.	% Imp.	Area (ac)	Weighted % Imp.	% Imp.	Area (ac)	Weighted % Imp.	
EX-1	0.05	100	0.00	0.0	2	0.05	2.0	90	0.00	0.00	2.0
EX-2	0.26	100	0.00	0.0	2	0.26	2.0	90	0.00	0.00	2.0
EX-3	0.39	100	0.02	4.2	2	0.38	1.9	90	0.00	0.00	6.1
EX-4	0.03	100	0.02	77.0	2	0.01	0.5	90	0.00	0.00	77.5
EX-5	2.69	100	0.16	6.0	2	2.50	1.9	90	0.03	1.00	8.9
EX-6	0.36	100	0.00	0.0	2	0.36	2.0	90	0.00	0.00	2.0

**STANDARD FORM SF-2
TIME OF CONCENTRATION**

Existing Conditions

Subdivision: _____
Location: CO, Colorado Springs

Project Name: Constitution Storage
Project No.: JDA000002
Calculated By: DDJ
Checked By: BS
Date: 7/8/22

SUB-BASIN						INITIAL/OVERLAND			TRAVEL TIME					T _c CHECK			FINAL
DATA						(T _i)			(T _t)					(URBANIZED BASINS)			
BASIN ID	D.A. (AC)	Hydrologic Soils Group	Impervious (%)	C ₁₀₀	C ₅	L (FT)	S (%)	T _i (MIN)	L (FT)	S (%)	C _v	VEL. (FPS)	T _t (MIN)	COMP. T _c (MIN)	TOTAL LENGTH (FT)	Urbanized T _c (MIN)	T _c (MIN)
EX-1	0.05	A	2.0	0.22	0.00	61	27.0	5.2	0	1.5	20.0	2.4	0.0	5.2	61.0	10.3	5.2
EX-2	0.26	A	2.0	0.22	0.00	100	3.0	14.0	130	7.3	15.0	4.1	0.5	14.5	230.0	11.3	11.3
EX-3	0.39	A	6.1	0.25	0.03	210	3.0	19.7	0	1.5	20.0	2.4	0.0	19.7	210.0	11.2	11.2
EX-4	0.03	A	77.5	0.63	0.53	16.5	2.0	3.4	16	1.5	20.0	2.4	0.1	3.5	32.5	10.2	5.0
EX-5	2.69	A	8.9	0.27	0.05	300	2.0	26.4	0	1.5	20.0	2.4	0.0	26.4	300.0	11.7	11.7
EX-6	0.36	A	2.0	0.22	0.00	200	5.0	16.7	0	1.5	20.0	2.4	0.0	16.7	200.0	11.1	11.1

NOTES:

$T_i = (0.395 * (1.1 - C_5) * (L)^{0.5}) / ((S)^{0.33})$, S in ft/ft

$T_t = L / 60V$ (Velocity From Fig. 501)

Velocity $V = C_v * S^{0.5}$, S in ft/ft

$T_c \text{ Check} = 10 + L / 180$

For Urbanized basins a minimum T_c of 5.0 minutes is required.

For non-urbanized basins a minimum T_c of 10.0 minutes is required

STANDARD FORM SF-3
STORM DRAINAGE SYSTEM DESIGN
(RATIONAL METHOD PROCEDURE)
Existing Conditions

Subdivision: _____
 Location: CO, Colorado Springs _____
 Design Storm: 2-Year _____

Project Name: Constitution Storage _____
 Project No.: JDA00002 _____
 Calculated By: DDJ _____
 Checked By: BS _____
 Date: 7/8/22 _____

STREET	Design Point	DIRECT RUNOFF							TOTAL RUNOFF				STREET		PIPE			TRAVEL TIME			REMARKS	
		Basin ID	Area (Ac)	Runoff Coeff.	Tc (min)	C*A (Ac)	I (in/hr)	Q (cfs)	Tc (min)	C*A (Ac)	I (in/hr)	Q (cfs)	Slope (%)	Street Flow (cfs)	Design Flow (cfs)	Slope (%)	Pipe Size (inches)	Length (ft)	Velocity (fps)	Tt (min)		
	1	EX-1	0.05	0.00	5.2	0.00	4.06	0.0													Free-release offsite to Eight Line Inc. property	
	2	EX-2	0.26	0.00	11.3	0.00	3.15	0.0													Free-release offsite to Alvarado property	
	3	EX-3	0.39	0.03	11.2	0.01	3.16	0.0													Free-release offsite to Peterson Road	
	4	EX-4	0.03	0.53	5.0	0.02	4.12	0.1													Free-release offsite to Constitution Avenue	
	5	EX-5	2.69	0.05	11.7	0.13	3.11	0.4													Free-release offsite to Eight Line Inc. property	
	6	EX-6	0.36	0.00	11.1	0.00	3.17	0.0													Free-release offsite to Canada Drive	



**STANDARD FORM SF-3
STORM DRAINAGE SYSTEM DESIGN
(RATIONAL METHOD PROCEDURE)
Existing Conditions**

Subdivision: _____
Location: CO, Colorado Springs
Design Storm: 100-Year

Project Name: Constitution Storage
Project No.: JDA000002
Calculated By: DDJ
Checked By: BS
Date: 7/8/22

STREET	Design Point	DIRECT RUNOFF							TOTAL RUNOFF				STREET		PIPE			TRAVEL TIME			REMARKS	
		Basin ID	Area (Ac)	Runoff Coeff.	Tc (min)	C*A (Ac)	I (in/hr)	Q (cfs)	Tc (min)	C*A (Ac)	I (in/hr)	Q (cfs)	Slope (%)	Street Flow (cfs)	Design Flow (cfs)	Slope (%)	Pipe Size (inches)	Length (ft)	Velocity (fps)	Tt (min)		
	1	EX-1	0.05	0.22	5.2	0.01	8.56	0.1													Free-release offsite to Eight Line Inc. property	
	2	EX-2	0.26	0.22	11.3	0.06	6.63	0.4													Free-release offsite to Alvarado property	
	3	EX-3	0.39	0.25	11.2	0.10	6.65	0.7													Free-release offsite to Peterson Road	
	4	EX-4	0.03	0.63	5.0	0.02	8.68	0.2													Free-release offsite to Constitution Avenue	
	5	EX-5	2.69	0.27	11.7	0.73	6.54	4.8													Free-release offsite to Eight Line Inc. property	
	6	EX-6	0.36	0.22	11.1	0.08	6.67	0.5													Free-release offsite to Canada Drive	

COMPOSITE % IMPERVIOUS CALCULATIONS

Proposed Conditions

Subdivision: _____
 Location: CO, Colorado Springs

Project Name: Constitution Storage
 Project No.: JDA000002
 Calculated By: DDJ
 Checked By: BS
 Date: 6/7/23

Basin ID	Total Area (ac)	Paved Roads			Lawns			Roofs			Basins Total Weighted % Imp.
		% Imp.	Area (ac)	Weighted % Imp.	% Imp.	Area (ac)	Weighted % Imp.	% Imp.	Area (ac)	Weighted % Imp.	
PR-1	0.22	100	0.00	0.0	2	0.22	2.0	90	0.00	0.00	2.0
PR-2A	0.05	100	0.01	13.2	2	0.04	1.7	90	0.00	0.00	14.9
PR-2B	0.01	100	0.009	77.2	2	0.003	0.5	90	0.00	0.00	77.7
PR-3	0.22	100	0.07	30.8	2	0.15	1.4	90	0.00	0.00	32.2
PR-4	0.25	100	0.09	35.9	2	0.16	1.3	90	0.00	0.00	37.2
PR-5	1.32	100	0.00	0.0	2	0.00	0.0	90	1.32	90.00	90.0
PR-6	0.92	100	0.62	67.9	2	0.29	0.6	90	0.00	0.00	68.5
PR-7	0.19	100	0.17	91.7	2	0.02	0.2	90	0.00	0.00	91.9
PR-8	0.13	100	0.00	0.0	2	0.13	2.0	90	0.00	0.00	2.0
PR-9	0.17	100	0.13	77.8	2	0.04	0.4	90	0.00	0.00	78.2
PR-10	0.31	100	0.00	0.0	2	0.31	2.0	90	0.00	0.00	2.0

**STANDARD FORM SF-2
TIME OF CONCENTRATION**

Proposed Conditions

Subdivision: _____
Location: CO, Colorado Springs

Project Name: Constitution Storage
Project No.: JDA000002
Calculated By: DDJ
Checked By: BS
Date: 6/7/23

SUB-BASIN DATA						INITIAL/OVERLAND (T _i)			TRAVEL TIME (T _t)					T _c CHECK (URBANIZED BASINS)			FINAL T _c (MIN)
BASIN ID	D.A. (AC)	Hydrologic Soils Group	Impervious (%)	C ₁₀₀	C ₅	L (FT)	S (%)	T _i (MIN)	L (FT)	S (%)	C _v	VEL. (FPS)	T _t (MIN)	COMP. T _c (MIN)	TOTAL LENGTH (FT)	Urbanized T _c (MIN)	T _c (MIN)
PR-1	0.22	A	2.0	0.22	0.00	100	10.0	9.4	0	3.0	20.0	3.5	0.0	9.4	100.0	10.6	9.4
PR-2A	0.05	A	14.9	0.30	0.10	70	5.0	9.0	0	2.0	20.0	2.8	0.0	9.0	70.0	10.4	9.0
PR-2B	0.01	A	77.7	0.63	0.53												5.0
PR-3	0.22	A	32.2	0.38	0.20												5.0
PR-4	0.25	A	37.2	0.40	0.23	93	6.0	8.5	0	3.0	20.0	3.5	0.0	8.5	93.0	10.5	8.5
PR-5	1.32	A	90.0	0.79	0.71												5.0
PR-6	0.92	A	68.5	0.55	0.44	57	2.0	7.2	370	0.5	20.0	1.4	4.4	11.6	427.0	12.4	11.6
PR-7	0.19	A	91.9	0.81	0.74	42	2.0	3.4	47	0.5	20.0	1.4	0.6	3.9	89.0	10.5	5.0
PR-8	0.13	A	2.0	0.22	0.00	25	2.0	8.0	390	2.5	20.0	3.2	2.1	10.0	415.0	12.3	10.0
PR-9	0.17	A	78.2	0.64	0.54	96	4.0	6.3	59	4.0	20.0	4.0	0.2	6.6	155.0	10.9	6.6
PR-10	0.31	A	2.0	0.22	0.00												5.0

NOTES:

$T_i = (0.395 * (1.1 - C_5) * (L)^{0.5}) / ((S)^{0.33})$, S in ft/ft

$T_t = L / 60V$ (Velocity From Fig. 501)

Velocity $V = C_v * S^{0.5}$, S in ft/ft

$T_c \text{ Check} = 10 + L / 180$

For Urbanized basins a minimum T_c of 5.0 minutes is required.

For non-urbanized basins a minimum T_c of 10.0 minutes is required

STANDARD FORM SF-3
STORM DRAINAGE SYSTEM DESIGN
(RATIONAL METHOD PROCEDURE)

Subdivision: _____
 Location: CO, Colorado Springs _____
 Design Storm: 2-Year _____

Project Name: Constitution Storage _____
 Project No.: JDA000002 _____
 Calculated By: DDJ _____
 Checked By: BS _____
 Date: 6/7/23 _____

STREET	Design Point	DIRECT RUNOFF							TOTAL RUNOFF				STREET		PIPE			TRAVEL TIME			REMARKS
		Basin ID	Area (Ac)	Runoff Coeff.	Tc (min)	C*A (Ac)	I (in/hr)	Q (cfs)	Tc (min)	C*A (Ac)	I (in/hr)	Q (cfs)	Slope (%)	Street Flow (cfs)	Design Flow (cfs)	Slope (%)	Pipe Size (inches)	Length (ft)	Velocity (fps)	Tt (min)	
	1	PR-1	0.22	0.00	9.4	0.00	3.37	0.0													Free Release to Alvarado property
	2A	PR-2A	0.05	0.10	9.0	0.00	3.43	0.0													Free Release to Peterson Road
	2B	PR-2B	0.01	0.53	5.0	0.01	4.12	0.0													Free Release to Peterson Road
	3	PR-3	0.22	0.20	5.0	0.04	4.12	0.2													Free Release to Constitution Avenue
	4	PR-4	0.25	0.23	8.5	0.06	3.49	0.2													Free Release to Canada Drive
	5	PR-5	1.32	0.71	5.0	0.94	4.12	3.9													Roof drains to DP-6B
	6A	PR-6	0.92	0.44	11.6	0.40	3.12	1.2													D-10R inlet to DP-6B
	6B								11.6	1.34	3.12	4.2									Max flow at DP-6B to DP-7
	7	PR-7	0.19	0.74	5.0	0.14	4.12	0.6	11.6	1.48	3.12	4.6									D-10R inlet & Maximum flow at DP-7 to DP-8
	8	PR-8	0.13	0.00	10.0	0.00	3.29	0.0	11.6	1.48	3.12	4.6									Area inlet & Flows from PR-5, PR-6, PR-7, PR-8 into FSD
	9	PR-9	0.17	0.54	6.6	0.09	3.79	0.3													Max flow at DP-9 into FSD
	10	PR-10	0.31	0.00	5.0	0.00	4.12	0.0	11.6	1.57	3.12	4.9									Maximum flow into FSD

STANDARD FORM SF-3
STORM DRAINAGE SYSTEM DESIGN
(RATIONAL METHOD PROCEDURE)

Subdivision: _____
 Location: CO, Colorado Springs _____
 Design Storm: 100-Year _____

Project Name: Constitution Storage _____
 Project No.: JDA000002 _____
 Calculated By: DDJ _____
 Checked By: BS _____
 Date: 6/7/23 _____

STREET	Design Point	DIRECT RUNOFF							TOTAL RUNOFF				STREET		PIPE			TRAVEL TIME			REMARKS
		Basin ID	Area (Ac)	Runoff Coeff.	Tc (min)	C*A (Ac)	I (in/hr)	Q (cfs)	Tc (min)	C*A (Ac)	I (in/hr)	Q (cfs)	Slope (%)	Street Flow (cfs)	Design Flow (cfs)	Slope (%)	Pipe Size (inches)	Length (ft)	Velocity (fps)	Tt (min)	
	1	PR-1	0.22	0.22	9.4	0.05	7.10	0.4													Free Release to Alvarado property
	2A	PR-2A	0.05	0.30	9.0	0.01	7.21	0.1													Free Release to Peterson Road
	2B	PR-2B	0.01	0.63	5.0	0.01	8.68	0.1													Free Release to Peterson Road
	3	PR-3	0.22	0.38	5.0	0.08	8.68	0.7													Free Release to Constitution Avenue
	4	PR-4	0.25	0.40	8.5	0.10	7.35	0.7													Free Release to Canada Drive
	5	PR-5	1.32	0.79	5.0	1.04	8.68	9.0													Roof drains to DP-6B
	6A	PR-6	0.92	0.55	11.6	0.50	6.56	3.3													D-10R inlet to DP-6B
	6B								11.6	1.54	6.56	10.1									Max flow at DP-6B to DP-7
	7	PR-7	0.19	0.81	5.0	0.15	8.68	1.3	11.6	1.69	6.56	11.1									D-10R inlet & Maximum flow at DP-7 to DP-8
	8	PR-8	0.13	0.22	10.0	0.03	6.92	0.2	11.6	1.72	6.56	11.3									Area inlet & Flows from PR-5, PR-6, PR-7, PR-8 into FSD
	9	PR-9	0.17	0.64	6.6	0.11	7.99	0.9													Max flow at DP-9 into FSD
	10	PR-10	0.31	0.22	5.0	0.07	8.68	0.6	11.6	1.90	6.56	12.5									Maximum flow into FSD

APPENDIX C

Hydraulic Computations

ALLOWABLE CAPACITY FOR ONE-HALF OF STREET (Minor & Major Storm)

(Based on Regulated Criteria for Maximum Allowable Flow Depth and Spread)

Project: Constitution Storage
Inlet ID: INLET DP-6A

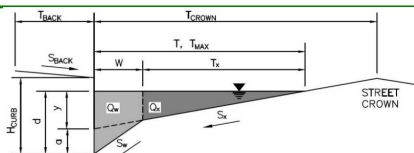

Gutter Geometry:							
Maximum Allowable Width for Spread Behind Curb	$T_{BACK} = 5.0$ ft						
Side Slope Behind Curb (leave blank for no conveyance credit behind curb)	$S_{BACK} = 0.020$ ft/ft						
Manning's Roughness Behind Curb (typically between 0.012 and 0.020)	$n_{BACK} = 0.013$						
Height of Curb at Gutter Flow Line	$H_{CURB} = 6.00$ inches						
Distance from Curb Face to Street Crown	$T_{CROWN} = 120.0$ ft						
Gutter Width	$W = 2.00$ ft						
Street Transverse Slope	$S_X = 0.005$ ft/ft						
Gutter Cross Slope (typically 2 inches over 24 inches or 0.083 ft/ft)	$S_W = 0.083$ ft/ft						
Street Longitudinal Slope - Enter 0 for sump condition	$S_0 = 0.000$ ft/ft						
Manning's Roughness for Street Section (typically between 0.012 and 0.020)	$n_{STREET} = 0.016$						
Max. Allowable Spread for Minor & Major Storm	<table border="1" style="display: inline-table; margin-right: 10px;"> <tr><th></th><th>Minor Storm</th><th>Major Storm</th></tr> <tr><td>T_{MAX}</td><td>25.0</td><td>40.0</td></tr> </table> ft		Minor Storm	Major Storm	T_{MAX}	25.0	40.0
	Minor Storm	Major Storm					
T_{MAX}	25.0	40.0					
Max. Allowable Depth at Gutter Flowline for Minor & Major Storm	<table border="1" style="display: inline-table; margin-right: 10px;"> <tr><th></th><th>Minor Storm</th><th>Major Storm</th></tr> <tr><td>d_{MAX}</td><td>6.0</td><td>8.0</td></tr> </table> inches		Minor Storm	Major Storm	d_{MAX}	6.0	8.0
	Minor Storm	Major Storm					
d_{MAX}	6.0	8.0					
Check boxes are not applicable in SUMP conditions	<input type="checkbox"/> <input type="checkbox"/>						
Maximum Capacity for 1/2 Street based On Allowable Spread							
Water Depth without Gutter Depression (Eq. ST-2)	<table border="1" style="display: inline-table; margin-right: 10px;"> <tr><th></th><th>Minor Storm</th><th>Major Storm</th></tr> <tr><td>y</td><td>1.62</td><td>2.59</td></tr> </table> inches		Minor Storm	Major Storm	y	1.62	2.59
	Minor Storm	Major Storm					
y	1.62	2.59					
Vertical Depth between Gutter Lip and Gutter Flowline (usually 2")	$d_c = 2.0$ inches						
Gutter Depression ($d_c - (W * S_X * 12)$)	$a = 1.86$ inches						
Water Depth at Gutter Flowline	$d = 3.48$ inches						
Allowable Spread for Discharge outside the Gutter Section W (T - W)	$T_X = 23.0$ ft						
Gutter Flow to Design Flow Ratio by FHWA HEC-22 method (Eq. ST-7)	$E_0 = 0.359$						
Discharge outside the Gutter Section W, carried in Section T_X	$Q_X = 0.0$ cfs						
Discharge within the Gutter Section W ($Q_T - Q_X$)	$Q_W = 0.0$ cfs						
Discharge Behind the Curb (e.g., sidewalk, driveways, & lawns)	$Q_{BACK} = 0.0$ cfs						
Maximum Flow Based On Allowable Spread	$Q_T =$ SUMP cfs						
Flow Velocity within the Gutter Section	$V = 0.0$ fps						
$V*d$ Product: Flow Velocity times Gutter Flowline Depth	$V*d = 0.0$						
Maximum Capacity for 1/2 Street based on Allowable Depth							
Theoretical Water Spread	<table border="1" style="display: inline-table; margin-right: 10px;"> <tr><th></th><th>Minor Storm</th><th>Major Storm</th></tr> <tr><td>T_{TH}</td><td>63.9</td><td>94.7</td></tr> </table> ft		Minor Storm	Major Storm	T_{TH}	63.9	94.7
	Minor Storm	Major Storm					
T_{TH}	63.9	94.7					
Theoretical Spread for Discharge outside the Gutter Section W (T - W)	$T_{X TH} = 61.9$ ft						
Gutter Flow to Design Flow Ratio by FHWA HEC-22 method (Eq. ST-7)	$E_0 = 0.112$						
Theoretical Discharge outside the Gutter Section W, carried in Section $T_{X TH}$	$Q_{X TH} = 0.0$ cfs						
Actual Discharge outside the Gutter Section W, (limited by distance T_{CROWN})	$Q_X = 0.0$ cfs						
Discharge within the Gutter Section W ($Q_d - Q_X$)	$Q_W = 0.0$ cfs						
Discharge Behind the Curb (e.g., sidewalk, driveways, & lawns)	$Q_{BACK} = 0.0$ cfs						
Total Discharge for Major & Minor Storm (Pre-Safety Factor)	$Q_d = 0.0$ cfs						
Average Flow Velocity Within the Gutter Section	$V = 0.0$ fps						
$V*d$ Product: Flow Velocity Times Gutter Flowline Depth	$V*d = 0.0$						
Slope-Based Depth Safety Reduction Factor for Major & Minor ($d \geq 6"$) Storm	$R =$ SUMP						
Max Flow Based on Allowable Depth (Safety Factor Applied)	$Q_d =$ SUMP cfs						
Resultant Flow Depth at Gutter Flowline (Safety Factor Applied)	$d =$ inches						
Resultant Flow Depth at Street Crown (Safety Factor Applied)	$d_{CROWN} =$ inches						
MINOR STORM Allowable Capacity is based on Depth Criterion							
MAJOR STORM Allowable Capacity is based on Depth Criterion							
Allowable Capacity	<table border="1" style="display: inline-table; margin-right: 10px;"> <tr><th></th><th>Minor Storm</th><th>Major Storm</th></tr> <tr><td>Q_{allow}</td><td>SUMP</td><td>SUMP</td></tr> </table> cfs		Minor Storm	Major Storm	Q_{allow}	SUMP	SUMP
	Minor Storm	Major Storm					
Q_{allow}	SUMP	SUMP					

INLET IN A SUMP OR SAG LOCATION

MHFD-Inlet, Version 5.01 (April 2021)

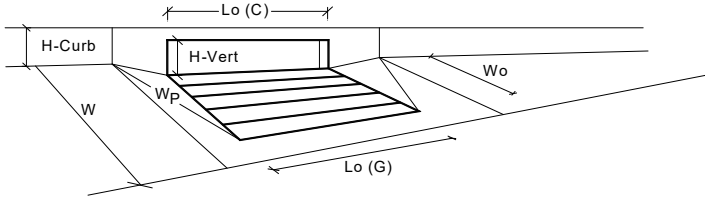

Design Information (Input)	MINOR	MAJOR	
Type of Inlet	Colorado Springs D-10-R		
Local Depression (additional to continuous gutter depression 'a' from above)	4.00	4.00	inches
Number of Unit Inlets (Grate or Curb Opening)	1	1	
Water Depth at Flowline (outside of local depression)	3.5	4.5	inches
Grate Information			
Length of a Unit Grate	N/A	N/A	feet
Width of a Unit Grate	N/A	N/A	feet
Area Opening Ratio for a Grate (typical values 0.15-0.90)	N/A	N/A	
Clogging Factor for a Single Grate (typical value 0.50 - 0.70)	N/A	N/A	
Grate Weir Coefficient (typical value 2.15 - 3.60)	N/A	N/A	
Grate Orifice Coefficient (typical value 0.60 - 0.80)	N/A	N/A	
Curb Opening Information			
Length of a Unit Curb Opening	10.00	10.00	feet
Height of Vertical Curb Opening in Inches	8.00	8.00	inches
Height of Curb Orifice Throat in Inches	8.00	8.00	inches
Angle of Throat (see USDCM Figure ST-5)	81.00	81.00	degrees
Side Width for Depression Pan (typically the gutter width of 2 feet)	2.00	2.00	feet
Clogging Factor for a Single Curb Opening (typical value 0.10)	0.10	0.10	
Curb Opening Weir Coefficient (typical value 2.3-3.7)	3.60	3.60	
Curb Opening Orifice Coefficient (typical value 0.60 - 0.70)	0.67	0.67	
Low Head Performance Reduction (Calculated)			
Depth for Grate Midwidth	N/A	N/A	ft
Depth for Curb Opening Weir Equation	0.12	0.21	ft
Combination Inlet Performance Reduction Factor for Long Inlets	0.33	0.42	
Curb Opening Performance Reduction Factor for Long Inlets	0.74	0.83	
Grated Inlet Performance Reduction Factor for Long Inlets	N/A	N/A	
Total Inlet Interception Capacity (assumes clogged condition)			
Inlet Capacity IS GOOD for Minor and Major Storms(>0 PEAK)	1.5	3.5	cfs
Q PEAK REQUIRED =	1.3	3.3	cfs

ALLOWABLE CAPACITY FOR ONE-HALF OF STREET (Minor & Major Storm)

(Based on Regulated Criteria for Maximum Allowable Flow Depth and Spread)

Project: Constitution Storage
Inlet ID: INLET DP-9

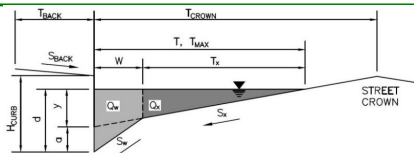

Gutter Geometry:

Maximum Allowable Width for Spread Behind Curb
 Side Slope Behind Curb (leave blank for no conveyance credit behind curb)
 Manning's Roughness Behind Curb (typically between 0.012 and 0.020)

T_{BACK} =	5.0	ft
S_{BACK} =	0.020	ft/ft
n_{BACK} =	0.013	

Height of Curb at Gutter Flow Line
 Distance from Curb Face to Street Crown
 Gutter Width
 Street Transverse Slope
 Gutter Cross Slope (typically 2 inches over 24 inches or 0.083 ft/ft)
 Street Longitudinal Slope - Enter 0 for sump condition
 Manning's Roughness for Street Section (typically between 0.012 and 0.020)

H_{CURB} =	6.00	inches
T_{CROWN} =	27.0	ft
W =	2.00	ft
S_X =	0.020	ft/ft
S_W =	0.083	ft/ft
S_0 =	0.041	ft/ft
n_{STREET} =	0.016	

Max. Allowable Spread for Minor & Major Storm
 Max. Allowable Depth at Gutter Flowline for Minor & Major Storm
 Allow Flow Depth at Street Crown (check box for yes, leave blank for no)

	Minor Storm	Major Storm	
T_{MAX} =	5.0	9.0	ft
d_{MAX} =	6.0	8.0	inches
	<input type="checkbox"/>	<input type="checkbox"/>	

Maximum Capacity for 1/2 Street based On Allowable Spread

Water Depth without Gutter Depression (Eq. ST-2)
 Vertical Depth between Gutter Lip and Gutter Flowline (usually 2")
 Gutter Depression ($d_c - (W * S_X * 12)$)
 Water Depth at Gutter Flowline
 Allowable Spread for Discharge outside the Gutter Section W ($T - W$)
 Gutter Flow to Design Flow Ratio by FHWA HEC-22 method (Eq. ST-7)
 Discharge outside the Gutter Section W , carried in Section T_X
 Discharge within the Gutter Section W ($Q_T - Q_X$)
 Discharge Behind the Curb (e.g., sidewalk, driveways, & lawns)
 Maximum Flow Based On Allowable Spread
 Flow Velocity within the Gutter Section
 $V*d$ Product: Flow Velocity times Gutter Flowline Depth

	Minor Storm	Major Storm	
y =	1.20	2.16	inches
d_c =	2.0	2.0	inches
a =	1.51	1.51	inches
d =	2.71	3.67	inches
T_X =	3.0	7.0	ft
E_0 =	0.889	0.629	
Q_X =	0.2	1.9	cfs
Q_W =	1.6	3.2	cfs
Q_{BACK} =	0.0	0.0	cfs
Q_T =	1.8	5.1	cfs
V =	5.5	7.2	fps
$V*d$ =	1.2	2.2	

Maximum Capacity for 1/2 Street based on Allowable Depth

Theoretical Water Spread
 Theoretical Spread for Discharge outside the Gutter Section W ($T - W$)
 Gutter Flow to Design Flow Ratio by FHWA HEC-22 method (Eq. ST-7)
 Theoretical Discharge outside the Gutter Section W , carried in Section $T_{X,TH}$
 Actual Discharge outside the Gutter Section W , (limited by distance T_{CROWN})
 Discharge within the Gutter Section W ($Q_d - Q_X$)
 Discharge Behind the Curb (e.g., sidewalk, driveways, & lawns)
 Total Discharge for Major & Minor Storm (Pre-Safety Factor)
 Average Flow Velocity Within the Gutter Section
 $V*d$ Product: Flow Velocity Times Gutter Flowline Depth
 Slope-Based Depth Safety Reduction Factor for Major & Minor ($d \geq 6$ " Storm)
 Max Flow Based on Allowable Depth (Safety Factor Applied)
 Resultant Flow Depth at Gutter Flowline (Safety Factor Applied)
 Resultant Flow Depth at Street Crown (Safety Factor Applied)

	Minor Storm	Major Storm	
T_{TH} =	18.7	27.0	ft
$T_{X,TH}$ =	16.7	25.0	ft
E_0 =	0.318	0.216	
$Q_{X,TH}$ =	19.1	56.3	cfs
Q_X =	19.1	56.3	cfs
Q_W =	8.9	15.5	cfs
Q_{BACK} =	0.0	3.4	cfs
Q =	28.0	75.2	cfs
V =	10.7	13.3	fps
$V*d$ =	5.3	8.9	
R =	0.58	0.47	
Q_d =	16.1	35.0	cfs
d =	5.10	6.41	inches
d_{CROWN} =	0.00	0.00	inches

MINOR STORM Allowable Capacity is based on Spread Criterion
 MAJOR STORM Allowable Capacity is based on Spread Criterion

	Minor Storm	Major Storm	
Q_{allow} =	1.8	5.1	cfs

Minor storm max. allowable capacity GOOD - greater than the design flow given on sheet 'Inlet Management'
Major storm max. allowable capacity GOOD - greater than the design flow given on sheet 'Inlet Management'

INLET ON A CONTINUOUS GRADE

MHFD-Inlet, Version 5.01 (April 2021)

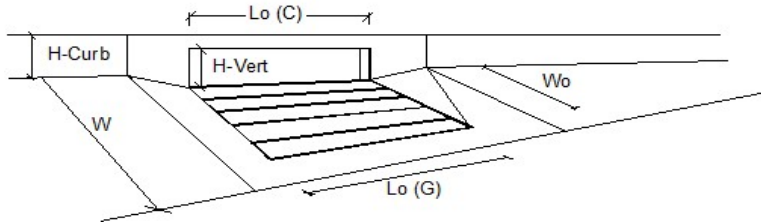

Design Information (Input)	MINOR	MAJOR	
Type of Inlet	Colorado Springs D-10-R		
Local Depression (additional to continuous gutter depression 'a')	4.0	4.0	inches
Total Number of Units in the Inlet (Grate or Curb Opening)	1	1	
Length of a Single Unit Inlet (Grate or Curb Opening)	6.00	6.00	ft
Width of a Unit Grate (cannot be greater than W, Gutter Width)	N/A	N/A	ft
Clogging Factor for a Single Unit Grate (typical min. value = 0.5)	N/A	N/A	
Clogging Factor for a Single Unit Curb Opening (typical min. value = 0.1)	0.10	0.10	
Street Hydraulics: OK - Q < Allowable Street Capacity			
Design Discharge for Half of Street (from <i>Inlet Management</i>)	0.5	0.9	cfs
Water Spread Width	1.8	2.2	ft
Water Depth at Flowline (outside of local depression)	1.8	2.0	inches
Water Depth at Street Crown (or at T _{MAX})	0.0	0.0	inches
Ratio of Gutter Flow to Design Flow	1.000	1.011	
Discharge outside the Gutter Section W, carried in Section T _x	0.0	0.0	cfs
Discharge within the Gutter Section W	0.5	0.9	cfs
Discharge Behind the Curb Face	0.0	0.0	cfs
Flow Area within the Gutter Section W	0.13	0.17	sq ft
Velocity within the Gutter Section W	4.0	5.2	fps
Water Depth for Design Condition	5.8	6.0	inches
Grate Analysis (Calculated)			
Total Length of Inlet Grate Opening	N/A	N/A	ft
Ratio of Grate Flow to Design Flow	N/A	N/A	
Under No-Clogging Condition			
Minimum Velocity Where Grate Splash-Over Begins	N/A	N/A	fps
Interception Rate of Frontal Flow	N/A	N/A	
Interception Rate of Side Flow	N/A	N/A	
Interception Capacity	N/A	N/A	cfs
Under Clogging Condition			
Clogging Coefficient for Multiple-unit Grate Inlet	N/A	N/A	
Clogging Factor for Multiple-unit Grate Inlet	N/A	N/A	
Effective (unclogged) Length of Multiple-unit Grate Inlet	N/A	N/A	ft
Minimum Velocity Where Grate Splash-Over Begins	N/A	N/A	fps
Interception Rate of Frontal Flow	N/A	N/A	
Interception Rate of Side Flow	N/A	N/A	
Actual Interception Capacity	N/A	N/A	cfs
Carry-Over Flow = Q _o - Q _s (to be applied to curb opening or next d/s inlet)	N/A	N/A	cfs
Curb or Slotted Inlet Opening Analysis (Calculated)			
Equivalent Slope S _e (based on grate carry-over)	0.250	0.250	ft/ft
Required Length L _T to Have 100% Interception	2.81	3.80	ft
Under No-Clogging Condition			
Effective Length of Curb Opening or Slotted Inlet (minimum of L, L _T)	2.81	3.80	ft
Interception Capacity	0.5	0.9	cfs
Under Clogging Condition			
Clogging Coefficient	1.00	1.00	
Clogging Factor for Multiple-unit Curb Opening or Slotted Inlet	0.08	0.08	
Effective (Unclogged) Length	5.40	5.40	ft
Actual Interception Capacity	0.5	0.9	cfs
Carry-Over Flow = Q _o - Q _s	0.0	0.0	cfs
Summary			
Total Inlet Interception Capacity	0.5	0.9	cfs
Total Inlet Carry-Over Flow (flow bypassing inlet)	0.0	0.0	cfs
Capture Percentage = Q _s /Q _o =	100	100	%

ALLOWABLE CAPACITY FOR ONE-HALF OF STREET (Minor & Major Storm)

(Based on Regulated Criteria for Maximum Allowable Flow Depth and Spread)

Project: Constitution Storage
Inlet ID: INLET DP-7

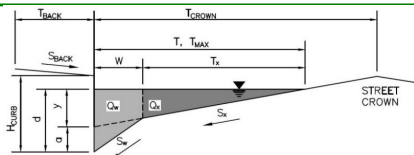

Gutter Geometry:

Maximum Allowable Width for Spread Behind Curb
 Side Slope Behind Curb (leave blank for no conveyance credit behind curb)
 Manning's Roughness Behind Curb (typically between 0.012 and 0.020)

Warning 01

Height of Curb at Gutter Flow Line
 Distance from Curb Face to Street Crown
 Gutter Width
 Street Transverse Slope
 Gutter Cross Slope (typically 2 inches over 24 inches or 0.083 ft/ft)
 Street Longitudinal Slope - Enter 0 for sump condition
 Manning's Roughness for Street Section (typically between 0.012 and 0.020)

T_{BACK} =	0.0	ft	
S_{BACK} =	0.000	ft/ft	
n_{BACK} =	0.035		
H_{CURB} =	6.00	inches	
T_{CROWN} =	36.0	ft	
W =	2.00	ft	
S_X =	0.020	ft/ft	
S_W =	0.083	ft/ft	
S_O =	0.000	ft/ft	
n_{STREET} =	0.016		
	Minor Storm	Major Storm	
T_{MAX} =	5.0	10.0	ft
d_{MAX} =	6.0	6.0	inches
	<input type="checkbox"/>	<input type="checkbox"/>	
	Minor Storm	Major Storm	
Q_{allow} =	SUMP	SUMP	cfs

Max. Allowable Spread for Minor & Major Storm
 Max. Allowable Depth at Gutter Flowline for Minor & Major Storm
 Check boxes are not applicable in SUMP conditions

MINOR STORM Allowable Capacity is based on Depth Criterion
 MAJOR STORM Allowable Capacity is based on Depth Criterion

Warning 01: Manning's n-value does not meet the USDCM recommended design range.

INLET IN A SUMP OR SAG LOCATION

MHFD-Inlet, Version 5.01 (April 2021)

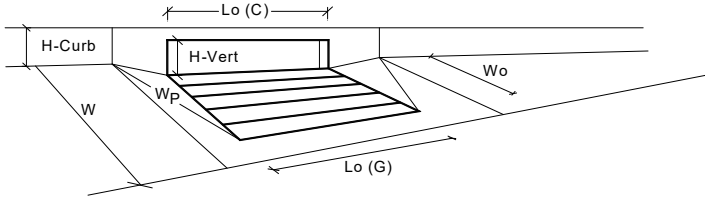

Design Information (Input)		MINOR		MAJOR	
Type of Inlet		Colorado Springs D-10-R			
Local Depression (additional to continuous gutter depression 'a' from above)	Type =	Colorado Springs D-10-R			
Number of Unit Inlets (Grate or Curb Opening)	a_{local} =	4.00	4.00	inches	
Water Depth at Flowline (outside of local depression)	No =	6	6		
Grate Information		MINOR		MAJOR	
Length of a Unit Grate	Ponding Depth =	2.7	3.9	inches	
Width of a Unit Grate	L_o (G) =	N/A	N/A	<input type="checkbox"/> Override Depths	
Area Opening Ratio for a Grate (typical values 0.15-0.90)	W_o =	N/A	N/A	feet	
Clogging Factor for a Single Grate (typical value 0.50 - 0.70)	A_{ratio} =	N/A	N/A		
Grate Weir Coefficient (typical value 2.15 - 3.60)	C_f (G) =	N/A	N/A		
Grate Orifice Coefficient (typical value 0.60 - 0.80)	C_w (G) =	N/A	N/A		
Curb Opening Information		MINOR		MAJOR	
Length of a Unit Curb Opening	C_o (G) =	N/A	N/A		
Height of Vertical Curb Opening in Inches	L_o (C) =	1.00	1.00	feet	
Height of Curb Orifice Throat in Inches	H_{vert} =	8.00	8.00	inches	
Angle of Throat (see USDCM Figure ST-5)	H_{throat} =	8.00	8.00	inches	
Side Width for Depression Pan (typically the gutter width of 2 feet)	Theta =	81.00	81.00	degrees	
Clogging Factor for a Single Curb Opening (typical value 0.10)	W_o =	2.00	2.00	feet	
Curb Opening Weir Coefficient (typical value 2.3-3.7)	C_f (C) =	0.10	0.10		
Curb Opening Orifice Coefficient (typical value 0.60 - 0.70)	C_w (C) =	3.60	3.60		
	C_o (C) =	0.67	0.67		
Grate Flow Analysis (Calculated)		MINOR		MAJOR	
Clogging Coefficient for Multiple Units	Coef =	N/A	N/A		
Clogging Factor for Multiple Units	Clog =	N/A	N/A		
Grate Capacity as a Weir (based on Modified HEC22 Method)		MINOR		MAJOR	
Interception without Clogging	Q_{wi} =	N/A	N/A	cfs	
Interception with Clogging	Q_{wa} =	N/A	N/A	cfs	
Grate Capacity as a Orifice (based on Modified HEC22 Method)		MINOR		MAJOR	
Interception without Clogging	Q_{oi} =	N/A	N/A	cfs	
Interception with Clogging	Q_{oa} =	N/A	N/A	cfs	
Grate Capacity as Mixed Flow		MINOR		MAJOR	
Interception without Clogging	Q_{mi} =	N/A	N/A	cfs	
Interception with Clogging	Q_{ma} =	N/A	N/A	cfs	
Resulting Grate Capacity (assumes clogged condition)	Q_{Grate} =	N/A	N/A	cfs	
Curb Opening Flow Analysis (Calculated)		MINOR		MAJOR	
Clogging Coefficient for Multiple Units	Coef =	1.00	1.00		
Clogging Factor for Multiple Units	Clog =	0.08	0.08		
Curb Opening as a Weir (based on Modified HEC22 Method)		MINOR		MAJOR	
Interception without Clogging	Q_{wi} =	1.2	6.1	cfs	
Interception with Clogging	Q_{wa} =	1.1	5.6	cfs	
Curb Opening as an Orifice (based on Modified HEC22 Method)		MINOR		MAJOR	
Interception without Clogging	Q_{oi} =	10.3	12.4	cfs	
Interception with Clogging	Q_{oa} =	9.5	11.3	cfs	
Curb Opening Capacity as Mixed Flow		MINOR		MAJOR	
Interception without Clogging	Q_{mi} =	3.3	8.1	cfs	
Interception with Clogging	Q_{ma} =	3.0	7.4	cfs	
Resulting Curb Opening Capacity (assumes clogged condition)	Q_{Curb} =	1.1	5.6	cfs	
Resultant Street Conditions		MINOR		MAJOR	
Total Inlet Length	L =	6.00	6.00	feet	
Resultant Street Flow Spread (based on street geometry from above)	T =	5.0	10.0	ft	
Resultant Flow Depth at Street Crown	d_{CROWN} =	0.0	0.0	inches	
Low Head Performance Reduction (Calculated)		MINOR		MAJOR	
Depth for Grate Midwidth	d_{Grate} =	N/A	N/A	ft	
Depth for Curb Opening Weir Equation	d_{Curb} =	0.06	0.16	ft	
Combination Inlet Performance Reduction Factor for Long Inlets	$RF_{Combination}$ =	0.32	0.46		
Curb Opening Performance Reduction Factor for Long Inlets	RF_{Curb} =	0.83	0.96		
Grated Inlet Performance Reduction Factor for Long Inlets	RF_{Grate} =	N/A	N/A		
Total Inlet Interception Capacity (assumes clogged condition)	Q_s =	1.1	5.6	cfs	
Inlet Capacity IS GOOD for Minor and Major Storms(>Q PEAK)	$Q_{PEAK REQUIRED}$ =	0.6	1.3	cfs	

Warning 1: Dimension entered is not a typical dimension for inlet type specified.

Figure 8-10. Inlet Capacity Chart Sump Conditions, Area (Type C) Inlet

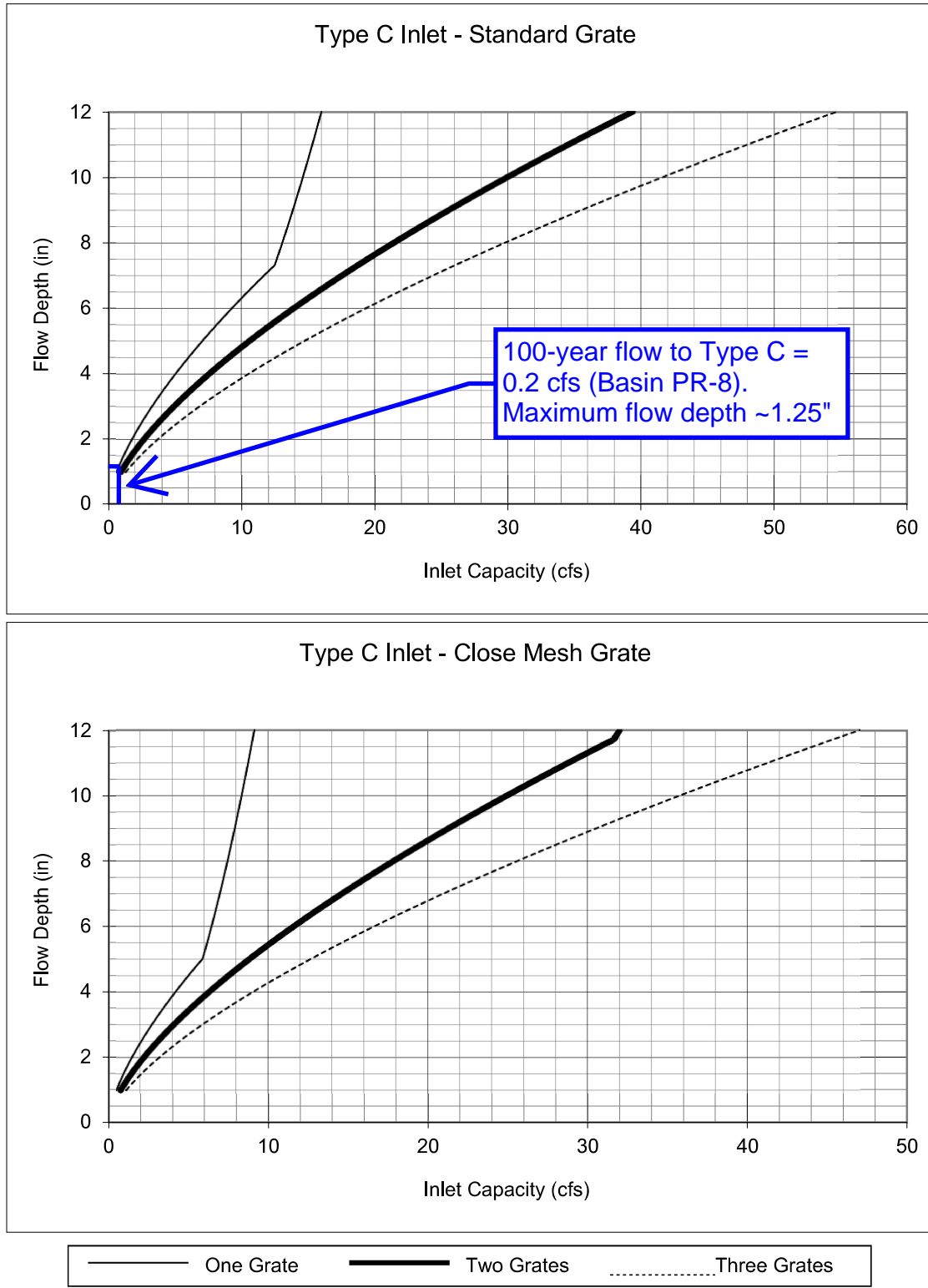

Notes:

1. The standard inlet parameters must apply to use these charts.

12" @ 0.5% Capacity

Project Description

Friction Method	Manning Formula
Solve For	Full Flow Capacity

Input Data

Roughness Coefficient	0.013	
Channel Slope	0.00500	ft/ft
Normal Depth	1.00	ft
Diameter	1.00	ft
Discharge	2.52	ft ³ /s

Results

Discharge	2.52	ft ³ /s
Normal Depth	1.00	ft
Flow Area	0.79	ft ²
Wetted Perimeter	3.14	ft
Hydraulic Radius	0.25	ft
Top Width	0.00	ft
Critical Depth	0.68	ft
Percent Full	100.0	%
Critical Slope	0.00770	ft/ft
Velocity	3.21	ft/s
Velocity Head	0.16	ft
Specific Energy	1.16	ft
Froude Number	0.00	
Maximum Discharge	2.71	ft ³ /s
Discharge Full	2.52	ft ³ /s
Slope Full	0.00500	ft/ft
Flow Type	SubCritical	

GVF Input Data

Downstream Depth	0.00	ft
Length	0.00	ft
Number Of Steps	0	

GVF Output Data

Upstream Depth	0.00	ft
Profile Description		
Profile Headloss	0.00	ft
Average End Depth Over Rise	0.00	%

12" @ 0.5% Capacity

GVF Output Data

Normal Depth Over Rise	100.00	%
Downstream Velocity	Infinity	ft/s
Upstream Velocity	Infinity	ft/s
Normal Depth	1.00	ft
Critical Depth	0.68	ft
Channel Slope	0.00500	ft/ft
Critical Slope	0.00770	ft/ft

18" @ 0.5% Capacity

Project Description

Friction Method	Manning Formula
Solve For	Full Flow Capacity

Input Data

Roughness Coefficient	0.013	
Channel Slope	0.00500	ft/ft
Normal Depth	1.50	ft
Diameter	1.50	ft
Discharge	7.43	ft ³ /s

Results

Discharge	7.43	ft ³ /s
Normal Depth	1.50	ft
Flow Area	1.77	ft ²
Wetted Perimeter	4.71	ft
Hydraulic Radius	0.38	ft
Top Width	0.00	ft
Critical Depth	1.06	ft
Percent Full	100.0	%
Critical Slope	0.00703	ft/ft
Velocity	4.20	ft/s
Velocity Head	0.27	ft
Specific Energy	1.77	ft
Froude Number	0.00	
Maximum Discharge	7.99	ft ³ /s
Discharge Full	7.43	ft ³ /s
Slope Full	0.00500	ft/ft
Flow Type	SubCritical	

GVF Input Data

Downstream Depth	0.00	ft
Length	0.00	ft
Number Of Steps	0	

GVF Output Data

Upstream Depth	0.00	ft
Profile Description		
Profile Headloss	0.00	ft
Average End Depth Over Rise	0.00	%

18" @ 0.5% Capacity

GVF Output Data

Normal Depth Over Rise	100.00	%
Downstream Velocity	Infinity	ft/s
Upstream Velocity	Infinity	ft/s
Normal Depth	1.50	ft
Critical Depth	1.06	ft
Channel Slope	0.00500	ft/ft
Critical Slope	0.00703	ft/ft

24" @ 0.5% Capacity

Project Description

Friction Method	Manning Formula
Solve For	Full Flow Capacity

Input Data

Roughness Coefficient	0.013	
Channel Slope	0.00500	ft/ft
Normal Depth	2.00	ft
Diameter	2.00	ft
Discharge	16.00	ft ³ /s

Results

Discharge	16.00	ft ³ /s
Normal Depth	2.00	ft
Flow Area	3.14	ft ²
Wetted Perimeter	6.28	ft
Hydraulic Radius	0.50	ft
Top Width	0.00	ft
Critical Depth	1.44	ft
Percent Full	100.0	%
Critical Slope	0.00662	ft/ft
Velocity	5.09	ft/s
Velocity Head	0.40	ft
Specific Energy	2.40	ft
Froude Number	0.00	
Maximum Discharge	17.21	ft ³ /s
Discharge Full	16.00	ft ³ /s
Slope Full	0.00500	ft/ft
Flow Type	SubCritical	

GVF Input Data

Downstream Depth	0.00	ft
Length	0.00	ft
Number Of Steps	0	

GVF Output Data

Upstream Depth	0.00	ft
Profile Description		
Profile Headloss	0.00	ft
Average End Depth Over Rise	0.00	%

24" @ 0.5% Capacity

GVF Output Data

Normal Depth Over Rise	100.00	%
Downstream Velocity	Infinity	ft/s
Upstream Velocity	Infinity	ft/s
Normal Depth	2.00	ft
Critical Depth	1.44	ft
Channel Slope	0.00500	ft/ft
Critical Slope	0.00662	ft/ft

Curb Chase Capacity

Project Description

Friction Method Manning Formula
Solve For Normal Depth

Input Data

Roughness Coefficient	0.013	
Channel Slope	0.02000	ft/ft
Bottom Width	2.00	ft
Discharge	0.87	ft ³ /s

Results

Normal Depth	0.12	ft
Flow Area	0.24	ft ²
Wetted Perimeter	2.24	ft
Hydraulic Radius	0.11	ft
Top Width	2.00	ft
Critical Depth	0.18	ft
Critical Slope	0.00544	ft/ft
Velocity	3.64	ft/s
Velocity Head	0.21	ft
Specific Energy	0.32	ft
Froude Number	1.85	
Flow Type	Supercritical	

Note: 100-year Release Rate from Private FSD-1 Pond

GVF Input Data

Downstream Depth	0.00	ft
Length	0.00	ft
Number Of Steps	0	

GVF Output Data

Upstream Depth	0.00	ft
Profile Description		
Profile Headloss	0.00	ft
Downstream Velocity	Infinity	ft/s
Upstream Velocity	Infinity	ft/s
Normal Depth	0.12	ft
Critical Depth	0.18	ft
Channel Slope	0.02000	ft/ft
Critical Slope	0.00544	ft/ft

Basin PR-6 Swale

Project Description

Friction Method	Manning Formula
Solve For	Normal Depth

Input Data

Roughness Coefficient	0.035	
Channel Slope	0.04000	ft/ft
Left Side Slope	3.00	ft/ft (H:V)
Right Side Slope	3.00	ft/ft (H:V)
Discharge	1.00	ft ³ /s

Results

Normal Depth	0.36	ft
Flow Area	0.38	ft ²
Wetted Perimeter	2.26	ft
Hydraulic Radius	0.17	ft
Top Width	2.15	ft
Critical Depth	0.37	ft
Critical Slope	0.03362	ft/ft
Velocity	2.60	ft/s
Velocity Head	0.11	ft
Specific Energy	0.46	ft
Froude Number	1.08	
Flow Type	Supercritical	

Note: Flow reduced from PR-6 basin flow since swale only captures small portion of landscaped flows

GVF Input Data

Downstream Depth	0.00	ft
Length	0.00	ft
Number Of Steps	0	

GVF Output Data

Upstream Depth	0.00	ft
Profile Description		
Profile Headloss	0.00	ft
Downstream Velocity	Infinity	ft/s
Upstream Velocity	Infinity	ft/s
Normal Depth	0.36	ft
Critical Depth	0.37	ft
Channel Slope	0.04000	ft/ft
Critical Slope	0.03362	ft/ft

Basin PR-8 Swale

Project Description

Friction Method	Manning Formula
Solve For	Normal Depth

Input Data

Roughness Coefficient	0.035	
Channel Slope	0.02000	ft/ft
Left Side Slope	3.00	ft/ft (H:V)
Right Side Slope	3.00	ft/ft (H:V)
Discharge	0.20	ft ³ /s

Results

Normal Depth	0.22	ft
Flow Area	0.15	ft ²
Wetted Perimeter	1.41	ft
Hydraulic Radius	0.11	ft
Top Width	1.34	ft
Critical Depth	0.19	ft
Critical Slope	0.04167	ft/ft
Velocity	1.34	ft/s
Velocity Head	0.03	ft
Specific Energy	0.25	ft
Froude Number	0.71	
Flow Type	Subcritical	

GVF Input Data

Downstream Depth	0.00	ft
Length	0.00	ft
Number Of Steps	0	

GVF Output Data

Upstream Depth	0.00	ft
Profile Description		
Profile Headloss	0.00	ft
Downstream Velocity	Infinity	ft/s
Upstream Velocity	Infinity	ft/s
Normal Depth	0.22	ft
Critical Depth	0.19	ft
Channel Slope	0.02000	ft/ft
Critical Slope	0.04167	ft/ft

APPENDIX D

Pond Computations

Site-Level Low Impact Development (LID) Design Effective Impervious Calculator

LID Credit by Impervious Reduction Factor (IRF) Method

UD-BMP (Version 3.06, November 2016)

User Input		
Calculated cells		
***Design Storm: 1-Hour Rain Depth	WQCV Event	0.60
***Minor Storm: 1-Hour Rain Depth	5-Year Event	1.50
***Major Storm: 1-Hour Rain Depth	100-Year Event	2.52
Optional User Defined Storm	CUHP	
(CUHP) NOAA 1 Hour Rainfall Depth and Frequency for User Defined Storm	100-Year Event	
Max Intensity for Optional User Defined Storm		0

Designer: DDJ
Company: Galloway & Co.
Date: June 2, 2023
Project: Constitution Storage
Location: FSD

SITE INFORMATION (USER-INPUT)

Sub-basin Identifier	PR-5	PR-6	PR-7	PR-8	PR-9	PR-10								
Receiving Pervious Area Soil Type	Sandy Loam	Sandy Loam	Sandy Loam	Sandy Loam	Sandy Loam	Sandy Loam								
Total Area (ac., Sum of DCIA, UIA, RPA, & SPA)	1.320	0.920	0.190	0.130	0.170	0.310								
Directly Connected Impervious Area (DCIA, acres)	1.320	0.620	0.170	0.000	0.130	0.000								
Unconnected Impervious Area (UIA, acres)	0.000	0.000	0.000	0.000	0.000	0.000								
Receiving Pervious Area (RPA, acres)	0.000	0.000	0.000	0.000	0.000	0.000								
Separate Pervious Area (SPA, acres)	0.000	0.300	0.020	0.130	0.040	0.310								
RPA Treatment Type: Conveyance (C), Volume (V), or Permeable Pavement (PP)	C	C	C	C	C	C								

CALCULATED RESULTS (OUTPUT)

Total Calculated Area (ac, check against input)	1.320	0.920	0.190	0.130	0.170	0.310								
Directly Connected Impervious Area (DCIA, %)	100.0%	67.4%	89.5%	0.0%	76.5%	0.0%								
Unconnected Impervious Area (UIA, %)	0.0%	0.0%	0.0%	0.0%	0.0%	0.0%								
Receiving Pervious Area (RPA, %)	0.0%	0.0%	0.0%	0.0%	0.0%	0.0%								
Separate Pervious Area (SPA, %)	0.0%	32.6%	10.5%	100.0%	23.5%	100.0%								
A _v (RPA / UIA)	0.000	0.000	0.000	0.000	0.000	0.000								
I _c Check	1.000	1.000	1.000	1.000	1.000	1.000								
f / I for WQCV Event:	1.7	1.7	1.7	1.7	1.7	1.7								
f / I for 5-Year Event:	0.5	0.5	0.5	0.5	0.5	0.5								
f / I for 100-Year Event:	0.3	0.3	0.3	0.3	0.3	0.3								
f / I for Optional User Defined Storm CUHP:														
IRF for WQCV Event:	1.00	1.00	1.00	1.00	1.00	1.00								
IRF for 5-Year Event:	1.00	1.00	1.00	1.00	1.00	1.00								
IRF for 100-Year Event:	1.00	1.00	1.00	1.00	1.00	1.00								
IRF for Optional User Defined Storm CUHP:														
Total Site Imperviousness: I _{total}	100.0%	67.4%	89.5%	0.0%	76.5%	0.0%								
Effective Imperviousness for WQCV Event:	100.0%	67.4%	89.5%	0.0%	76.5%	0.0%								
Effective Imperviousness for 5-Year Event:	100.0%	67.4%	89.5%	0.0%	76.5%	0.0%								
Effective Imperviousness for 100-Year Event:	100.0%	67.4%	89.5%	0.0%	76.5%	0.0%								
Effective Imperviousness for Optional User Defined Storm CUHP:														

LID / EFFECTIVE IMPERVIOUSNESS CREDITS

WQCV Event CREDIT: Reduce Detention By:	N/A	0.0%	0.0%	0.0%	N/A	0.0%	N/A	N/A	N/A	N/A	N/A	N/A	N/A	N/A
This line only for 10-Year Event	N/A	N/A	N/A	N/A	N/A	N/A	N/A	N/A	N/A	N/A	N/A	N/A	N/A	N/A
100-Year Event CREDIT**: Reduce Detention By:	N/A	0.0%	0.0%	0.1%	N/A	0.2%	N/A	N/A	N/A	N/A	N/A	N/A	N/A	N/A
User Defined CUHP CREDIT: Reduce Detention By:														

Total Site Imperviousness:	73.7%
Total Site Effective Imperviousness for WQCV Event:	73.7%
Total Site Effective Imperviousness for 5-Year Event:	73.7%
Total Site Effective Imperviousness for 100-Year Event:	73.7%
Total Site Effective Imperviousness for Optional User Defined Storm CUHP:	

Notes:

- * Use Green-Ampt average infiltration rate values from Table 3-3.
- ** Flood control detention volume credits based on empirical equations from Storage Chapter of USDCM.
- *** Method assumes that 1-hour rainfall depth is equivalent to 1-hour intensity for calculation purposes

DETENTION BASIN STAGE-STORAGE TABLE BUILDER

MHFD-Detention, Version 4.05 (January 2022)

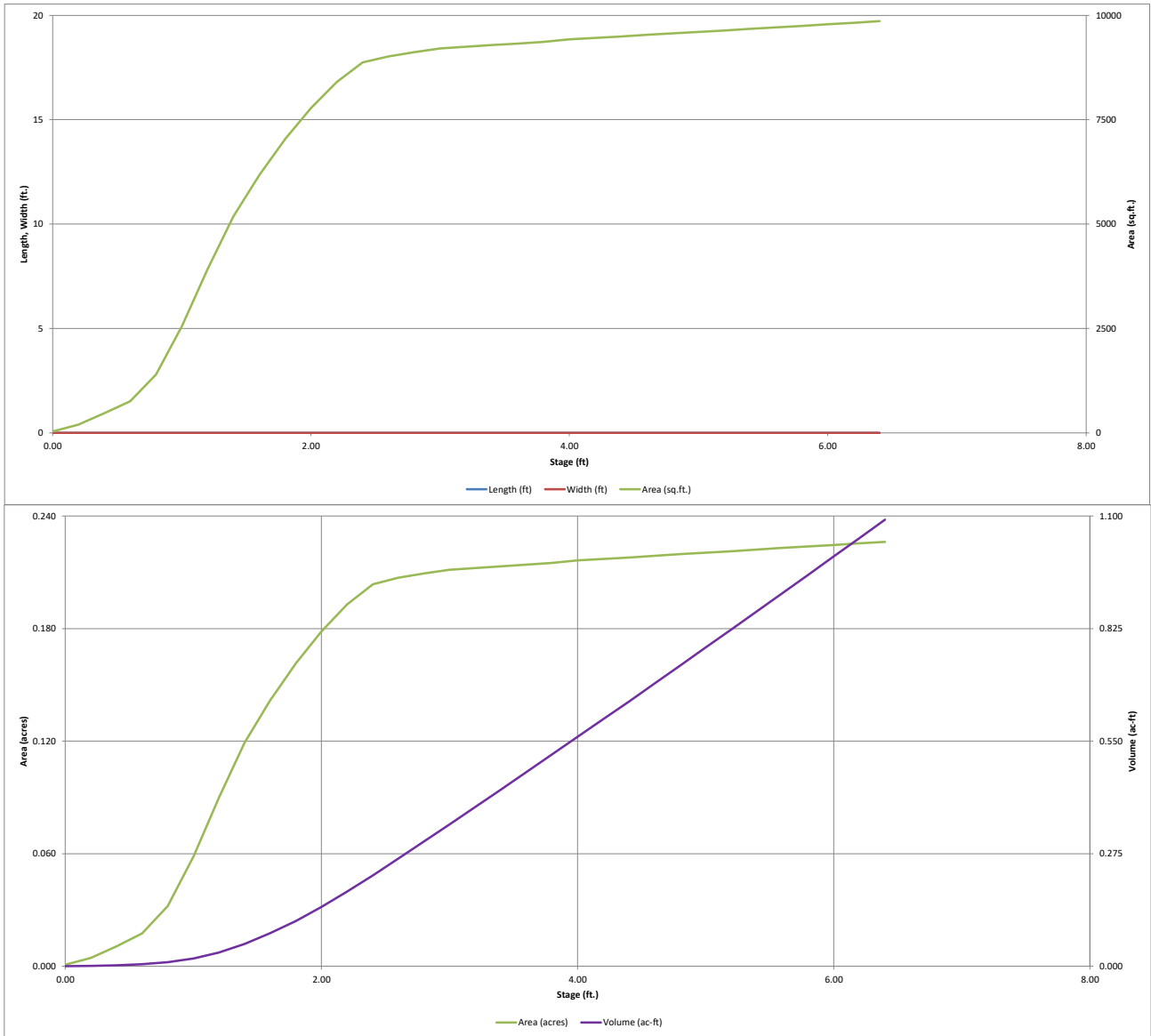

DETENTION BASIN OUTLET STRUCTURE DESIGN

MHFD-Detention, Version 4.05 (January 2022)

Project: Constitution Storage

Basin ID: FSD-1

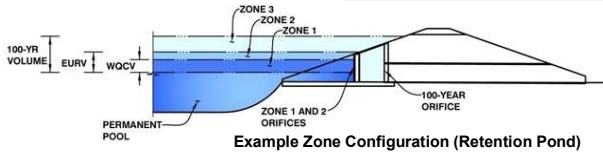

Example Zone Configuration (Retention Pond)

	Estimated Stage (ft)	Estimated Volume (ac-ft)	Outlet Type
Zone 1 (WQCV)	1.56	0.074	Orifice Plate
Zone 2 (EURV)	2.72	0.213	Orifice Plate
Zone 3 (100-year)	3.33	0.129	Weir&Pipe (Restrict)
Total (all zones)		0.416	

User Input: Orifice at Underdrain Outlet (typically used to drain WQCV in a Filtration BMP)

Underdrain Orifice Invert Depth =	N/A	ft (distance below the filtration media surface)
Underdrain Orifice Diameter =	N/A	inches

Calculated Parameters for Underdrain	
Underdrain Orifice Area =	N/A ft ²
Underdrain Orifice Centroid =	N/A feet

User Input: Orifice Plate with one or more orifices or Elliptical Slot Weir (typically used to drain WQCV and/or EURV in a sedimentation BMP)

Centroid of Lowest Orifice =	0.00	ft (relative to basin bottom at Stage = 0 ft)
Depth at top of Zone using Orifice Plate =	2.72	ft (relative to basin bottom at Stage = 0 ft)
Orifice Plate: Orifice Vertical Spacing =	N/A	inches
Orifice Plate: Orifice Area per Row =	N/A	sq. inches

Calculated Parameters for Plate	
WQ Orifice Area per Row =	N/A ft ²
Elliptical Half-Width =	N/A feet
Elliptical Slot Centroid =	N/A feet
Elliptical Slot Area =	N/A ft ²

User Input: Stage and Total Area of Each Orifice Row (numbered from lowest to highest)

	Row 1 (required)	Row 2 (optional)	Row 3 (optional)	Row 4 (optional)	Row 5 (optional)	Row 6 (optional)	Row 7 (optional)	Row 8 (optional)
Stage of Orifice Centroid (ft)	0.00	0.91	1.58	2.45				
Orifice Area (sq. inches)	0.44	0.60	0.79	0.44				

	Row 9 (optional)	Row 10 (optional)	Row 11 (optional)	Row 12 (optional)	Row 13 (optional)	Row 14 (optional)	Row 15 (optional)	Row 16 (optional)
Stage of Orifice Centroid (ft)								
Orifice Area (sq. inches)								

User Input: Vertical Orifice (Circular or Rectangular)

	Not Selected	Not Selected	
Invert of Vertical Orifice =	N/A	N/A	ft (relative to basin bottom at Stage = 0 ft)
Depth at top of Zone using Vertical Orifice =	N/A	N/A	ft (relative to basin bottom at Stage = 0 ft)
Vertical Orifice Diameter =	N/A	N/A	inches

Calculated Parameters for Vertical Orifice		
	Not Selected	Not Selected
Vertical Orifice Area =	N/A	N/A
Vertical Orifice Centroid =	N/A	N/A

User Input: Overflow Weir (Dropbox with Flat or Sloped Grate and Outlet Pipe OR Rectangular/Trapezoidal Weir and No Outlet Pipe)

	Zone 3 Weir	Not Selected	
Overflow Weir Front Edge Height, Ho =	3.25	N/A	ft (relative to basin bottom at Stage = 0 ft)
Overflow Weir Front Edge Length =	2.92	N/A	feet
Overflow Weir Grate Slope =	0.00	N/A	H:V
Horiz. Length of Weir Sides =	2.92	N/A	feet
Overflow Grate Type =	Type C Grate	N/A	
Debris Clogging % =	50%	N/A	%

Calculated Parameters for Overflow Weir		
	Zone 3 Weir	Not Selected
Height of Grate Upper Edge, H _u =	3.25	N/A
Overflow Weir Slope Length =	2.92	N/A
Grate Open Area / 100-yr Orifice Area =	22.25	N/A
Overflow Grate Open Area w/o Debris =	5.93	N/A
Overflow Grate Open Area w/ Debris =	2.97	N/A

User Input: Outlet Pipe w/ Flow Restriction Plate (Circular Orifice, Restrictor Plate, or Rectangular Orifice)

	Zone 3 Restrictor	Not Selected	
Depth to Invert of Outlet Pipe =	0.00	N/A	ft (distance below basin bottom at Stage = 0 ft)
Outlet Pipe Diameter =	18.00	N/A	inches
Restrictor Plate Height Above Pipe Invert =	3.75		inches

Calculated Parameters for Outlet Pipe w/ Flow Restriction Plate		
	Zone 3 Restrictor	Not Selected
Outlet Orifice Area =	0.27	N/A
Outlet Orifice Centroid =	0.18	N/A
Half-Central Angle of Restrictor Plate on Pipe =	0.95	N/A

User Input: Emergency Spillway (Rectangular or Trapezoidal)

Spillway Invert Stage =	3.40	ft (relative to basin bottom at Stage = 0 ft)
Spillway Crest Length =	20.00	feet
Spillway End Slopes =	0.00	H:V
Freeboard above Max Water Surface =	1.00	feet

Calculated Parameters for Spillway	
Spillway Design Flow Depth =	0.29 feet
Stage at Top of Freeboard =	4.69 feet
Basin Area at Top of Freeboard =	0.22 acres
Basin Volume at Top of Freeboard =	0.71 acre-ft

Routed Hydrograph Results

The user can override the default CUHP hydrographs and runoff volumes by entering new values in the Inflow Hydrographs table (Columns W through AF).

	WQCV	EURV	2 Year	5 Year	10 Year	25 Year	50 Year	100 Year	500 Year
Design Storm Return Period =	N/A	N/A	1.19	1.50	1.75	2.00	2.25	2.52	3.00
One-Hour Rainfall Depth (in) =	0.074	0.287	0.197	0.256	0.304	0.362	0.419	0.487	0.601
CUHP Runoff Volume (acre-ft) =	N/A	N/A	0.197	0.256	0.304	0.362	0.419	0.487	0.601
Inflow Hydrograph Volume (acre-ft) =	N/A	N/A	0.0	0.0	0.1	0.6	1.2	2.0	3.1
CUHP Predevelopment Peak Q (cfs) =	N/A	N/A							
OPTIONAL Override Predevelopment Peak Q (cfs) =	N/A	N/A							
Predevelopment Unit Peak Flow, q (cfs/acre) =	N/A	N/A	0.01	0.016	0.022	0.20	0.40	0.65	1.04
Peak Inflow Q (cfs) =	N/A	N/A	3.6	4.6	5.3	6.6	7.7	9.3	11.5
Peak Outflow Q (cfs) =	0.034	0.087	0.066	0.078	0.088	0.097	0.141	0.869	3.577
Ratio Peak Outflow to Predevelopment Q =	N/A	N/A	N/A	1.6	1.3	0.2	0.1	0.4	1.1
Structure Controlling Flow =	Plate	Plate	Plate	Plate	Plate	Plate	Overflow Weir 1	Overflow Weir 1	Spillway
Max Velocity through Grate 1 (fps) =	N/A	N/A	N/A	N/A	N/A	N/A	0.0	0.1	0.3
Max Velocity through Grate 2 (fps) =	N/A	N/A	N/A	N/A	N/A	N/A	N/A	N/A	N/A
Time to Drain 97% of Inflow Volume (hours) =	38	73	62	70	76	82	87	85	83
Time to Drain 99% of Inflow Volume (hours) =	40	79	67	76	82	89	95	94	93
Maximum Ponding Depth (ft) =	1.56	2.72	2.22	2.51	2.73	3.01	3.27	3.37	3.48
Area at Maximum Ponding Depth (acres) =	0.14	0.21	0.19	0.21	0.21	0.21	0.21	0.21	0.21
Maximum Volume Stored (acre-ft) =	0.075	0.288	0.186	0.244	0.290	0.347	0.402	0.423	0.449

DETENTION BASIN OUTLET STRUCTURE DESIGN

MHFD-Detention, Version 4.05 (January 2022)

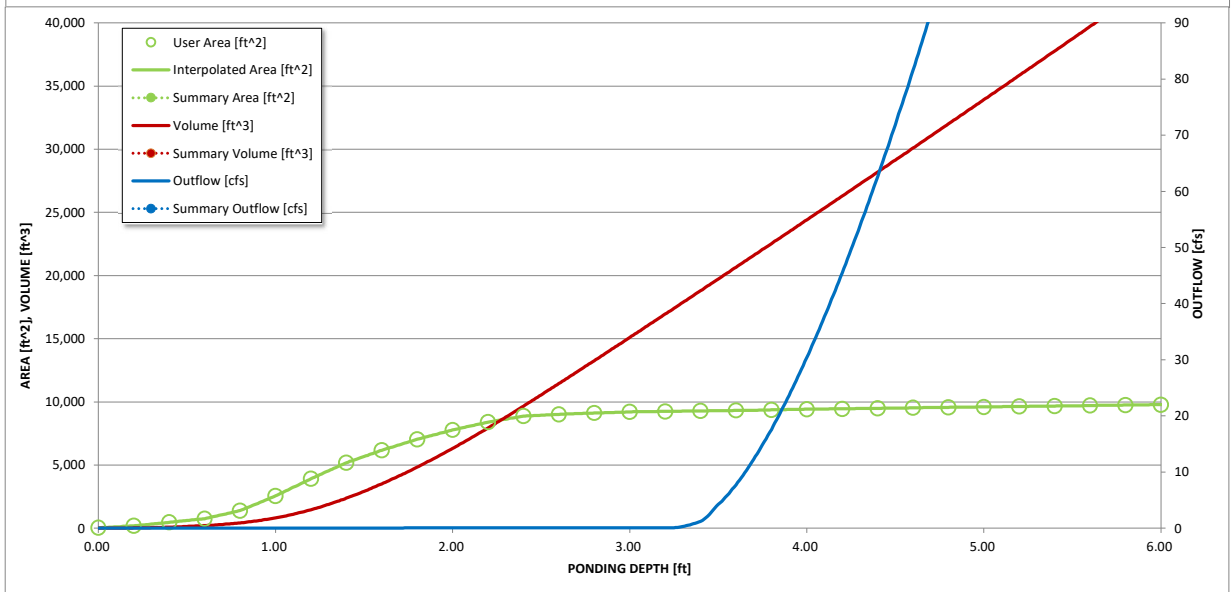
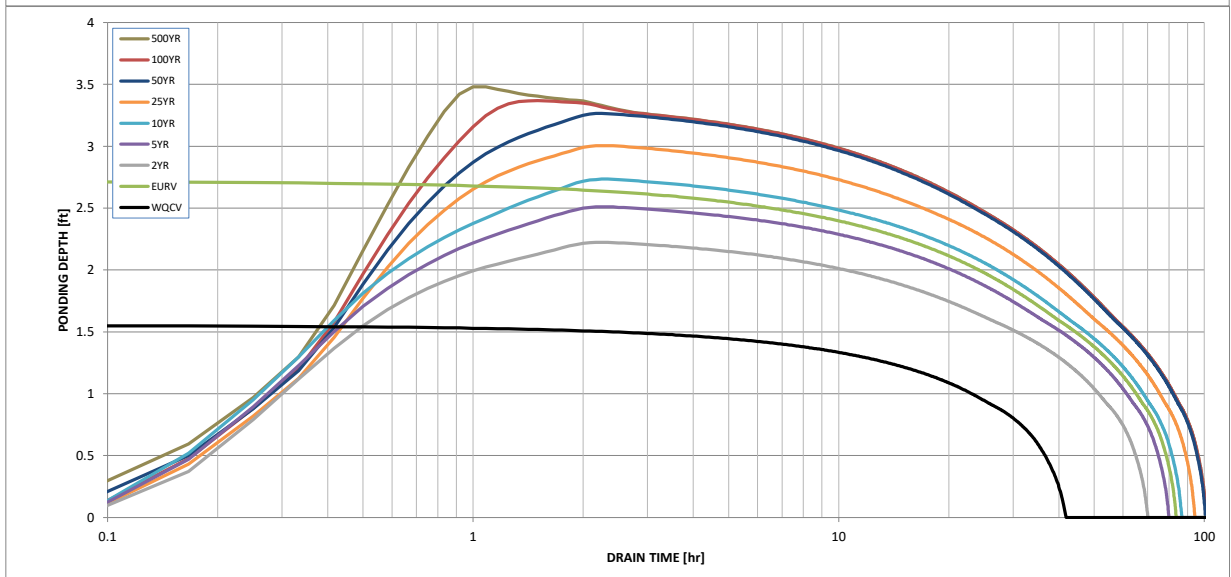
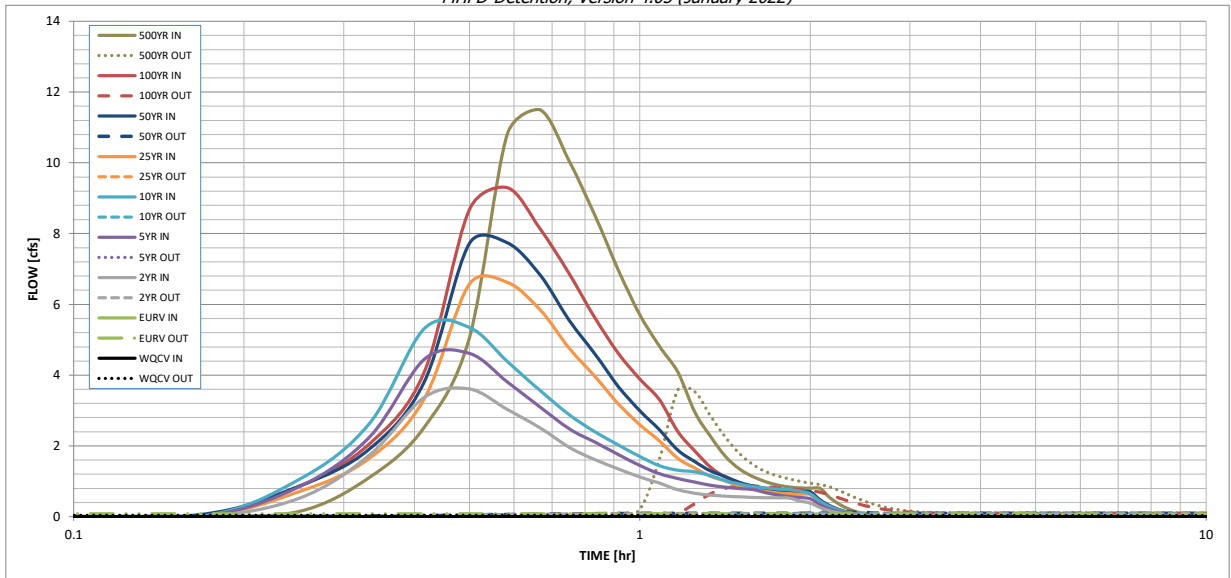

S-A-V-D Chart Axis Override	X-axis	Left Y-Axis	Right Y-Axis
minimum bound			
maximum bound			

DETENTION BASIN OUTLET STRUCTURE DESIGN

Outflow Hydrograph Workbook Filename: _____

Inflow Hydrographs

The user can override the calculated inflow hydrographs from this workbook with inflow hydrographs developed in a separate program.

Time Interval	SOURCE	CUHP	CUHP	CUHP	CUHP	CUHP	CUHP	CUHP	CUHP	CUHP
	TIME	WQCV [cfs]	EURV [cfs]	2 Year [cfs]	5 Year [cfs]	10 Year [cfs]	25 Year [cfs]	50 Year [cfs]	100 Year [cfs]	500 Year [cfs]
5.00 min	0:00:00	0.00	0.00	0.00	0.00	0.00	0.00	0.00	0.00	0.00
	0:05:00	0.00	0.00	0.00	0.00	0.00	0.00	0.00	0.00	0.00
	0:10:00	0.00	0.00	0.00	0.00	0.00	0.00	0.00	0.06	0.01
	0:15:00	0.00	0.00	0.52	0.85	1.05	0.70	0.86	0.85	1.11
	0:20:00	0.00	0.00	1.75	2.26	2.64	1.65	1.91	2.07	2.53
	0:25:00	0.00	0.00	3.37	4.45	5.32	3.34	3.82	4.09	5.07
	0:30:00	0.00	0.00	3.61	4.62	5.35	6.57	7.72	8.69	10.80
	0:35:00	0.00	0.00	3.03	3.81	4.39	6.62	7.74	9.30	11.49
	0:40:00	0.00	0.00	2.51	3.10	3.56	5.84	6.83	8.13	10.06
	0:45:00	0.00	0.00	1.96	2.48	2.88	4.76	5.55	6.87	8.51
	0:50:00	0.00	0.00	1.61	2.11	2.40	3.96	4.60	5.61	6.96
	0:55:00	0.00	0.00	1.35	1.75	2.02	3.18	3.68	4.61	5.70
	1:00:00	0.00	0.00	1.12	1.45	1.70	2.60	2.99	3.89	4.81
	1:05:00	0.00	0.00	0.95	1.21	1.44	2.14	2.45	3.30	4.09
	1:10:00	0.00	0.00	0.76	1.08	1.31	1.65	1.88	2.41	2.96
	1:15:00	0.00	0.00	0.66	0.98	1.27	1.37	1.56	1.86	2.27
	1:20:00	0.00	0.00	0.61	0.89	1.16	1.14	1.29	1.40	1.70
	1:25:00	0.00	0.00	0.58	0.83	1.02	1.00	1.13	1.11	1.34
	1:30:00	0.00	0.00	0.56	0.79	0.92	0.86	0.97	0.94	1.13
	1:35:00	0.00	0.00	0.55	0.77	0.86	0.77	0.87	0.83	0.99
	1:40:00	0.00	0.00	0.54	0.68	0.81	0.71	0.80	0.75	0.90
	1:45:00	0.00	0.00	0.53	0.61	0.78	0.67	0.76	0.70	0.84
	1:50:00	0.00	0.00	0.53	0.57	0.76	0.65	0.73	0.68	0.81
	1:55:00	0.00	0.00	0.44	0.54	0.72	0.63	0.71	0.67	0.80
	2:00:00	0.00	0.00	0.38	0.50	0.65	0.63	0.71	0.67	0.80
	2:05:00	0.00	0.00	0.25	0.34	0.43	0.42	0.47	0.45	0.54
	2:10:00	0.00	0.00	0.17	0.22	0.28	0.28	0.31	0.30	0.35
	2:15:00	0.00	0.00	0.11	0.14	0.18	0.18	0.20	0.19	0.23
	2:20:00	0.00	0.00	0.06	0.09	0.11	0.11	0.12	0.12	0.14
	2:25:00	0.00	0.00	0.04	0.05	0.07	0.07	0.08	0.07	0.09
	2:30:00	0.00	0.00	0.02	0.03	0.04	0.04	0.04	0.04	0.05
	2:35:00	0.00	0.00	0.01	0.01	0.01	0.02	0.02	0.02	0.02
	2:40:00	0.00	0.00	0.00	0.00	0.00	0.00	0.00	0.00	0.00
	2:45:00	0.00	0.00	0.00	0.00	0.00	0.00	0.00	0.00	0.00
	2:50:00	0.00	0.00	0.00	0.00	0.00	0.00	0.00	0.00	0.00
	2:55:00	0.00	0.00	0.00	0.00	0.00	0.00	0.00	0.00	0.00
	3:00:00	0.00	0.00	0.00	0.00	0.00	0.00	0.00	0.00	0.00
	3:05:00	0.00	0.00	0.00	0.00	0.00	0.00	0.00	0.00	0.00
	3:10:00	0.00	0.00	0.00	0.00	0.00	0.00	0.00	0.00	0.00
	3:15:00	0.00	0.00	0.00	0.00	0.00	0.00	0.00	0.00	0.00
	3:20:00	0.00	0.00	0.00	0.00	0.00	0.00	0.00	0.00	0.00
	3:25:00	0.00	0.00	0.00	0.00	0.00	0.00	0.00	0.00	0.00
	3:30:00	0.00	0.00	0.00	0.00	0.00	0.00	0.00	0.00	0.00
	3:35:00	0.00	0.00	0.00	0.00	0.00	0.00	0.00	0.00	0.00
	3:40:00	0.00	0.00	0.00	0.00	0.00	0.00	0.00	0.00	0.00
	3:45:00	0.00	0.00	0.00	0.00	0.00	0.00	0.00	0.00	0.00
	3:50:00	0.00	0.00	0.00	0.00	0.00	0.00	0.00	0.00	0.00
	3:55:00	0.00	0.00	0.00	0.00	0.00	0.00	0.00	0.00	0.00
4:00:00	0.00	0.00	0.00	0.00	0.00	0.00	0.00	0.00	0.00	
4:05:00	0.00	0.00	0.00	0.00	0.00	0.00	0.00	0.00	0.00	
4:10:00	0.00	0.00	0.00	0.00	0.00	0.00	0.00	0.00	0.00	
4:15:00	0.00	0.00	0.00	0.00	0.00	0.00	0.00	0.00	0.00	
4:20:00	0.00	0.00	0.00	0.00	0.00	0.00	0.00	0.00	0.00	
4:25:00	0.00	0.00	0.00	0.00	0.00	0.00	0.00	0.00	0.00	
4:30:00	0.00	0.00	0.00	0.00	0.00	0.00	0.00	0.00	0.00	
4:35:00	0.00	0.00	0.00	0.00	0.00	0.00	0.00	0.00	0.00	
4:40:00	0.00	0.00	0.00	0.00	0.00	0.00	0.00	0.00	0.00	
4:45:00	0.00	0.00	0.00	0.00	0.00	0.00	0.00	0.00	0.00	
4:50:00	0.00	0.00	0.00	0.00	0.00	0.00	0.00	0.00	0.00	
4:55:00	0.00	0.00	0.00	0.00	0.00	0.00	0.00	0.00	0.00	
5:00:00	0.00	0.00	0.00	0.00	0.00	0.00	0.00	0.00	0.00	
5:05:00	0.00	0.00	0.00	0.00	0.00	0.00	0.00	0.00	0.00	
5:10:00	0.00	0.00	0.00	0.00	0.00	0.00	0.00	0.00	0.00	
5:15:00	0.00	0.00	0.00	0.00	0.00	0.00	0.00	0.00	0.00	
5:20:00	0.00	0.00	0.00	0.00	0.00	0.00	0.00	0.00	0.00	
5:25:00	0.00	0.00	0.00	0.00	0.00	0.00	0.00	0.00	0.00	
5:30:00	0.00	0.00	0.00	0.00	0.00	0.00	0.00	0.00	0.00	
5:35:00	0.00	0.00	0.00	0.00	0.00	0.00	0.00	0.00	0.00	
5:40:00	0.00	0.00	0.00	0.00	0.00	0.00	0.00	0.00	0.00	
5:45:00	0.00	0.00	0.00	0.00	0.00	0.00	0.00	0.00	0.00	
5:50:00	0.00	0.00	0.00	0.00	0.00	0.00	0.00	0.00	0.00	
5:55:00	0.00	0.00	0.00	0.00	0.00	0.00	0.00	0.00	0.00	
6:00:00	0.00	0.00	0.00	0.00	0.00	0.00	0.00	0.00	0.00	

Design Procedure Form: Extended Detention Basin (EDB)

UD-BMP (Version 3.07, March 2018)

Sheet 1 of 3

Designer: DDJ
Company: Galloway
Date: June 2, 2023
Project: Constitution Storage
Location: _____

1. Basin Storage Volume

A) Effective Imperviousness of Tributary Area, I_a

B) Tributary Area's Imperviousness Ratio ($i = I_a / 100$)

C) Contributing Watershed Area

D) For Watersheds Outside of the Denver Region, Depth of Average Runoff Producing Storm

E) Design Concept
(Select EURV when also designing for flood control)

F) Design Volume (WQCV) Based on 40-hour Drain Time
($V_{DESIGN} = (1.0 * (0.91 * i^3 - 1.19 * i^2 + 0.78 * i) / 12 * Area)$)

G) For Watersheds Outside of the Denver Region, Water Quality Capture Volume (WQCV) Design Volume
($V_{WQCV\ OTHER} = (d_s * V_{DESIGN} / 0.43)$)

H) User Input of Water Quality Capture Volume (WQCV) Design Volume
(Only if a different WQCV Design Volume is desired)

I) NRCS Hydrologic Soil Groups of Tributary Watershed
 i) Percentage of Watershed consisting of Type A Soils
 ii) Percentage of Watershed consisting of Type B Soils
 iii) Percentage of Watershed consisting of Type C/D Soils

J) Excess Urban Runoff Volume (EURV) Design Volume
 For HSG A: $EURV_A = 1.68 * i^{1.28}$
 For HSG B: $EURV_B = 1.36 * i^{1.08}$
 For HSG C/D: $EURV_{C/D} = 1.20 * i^{1.08}$

K) User Input of Excess Urban Runoff Volume (EURV) Design Volume
(Only if a different EURV Design Volume is desired)

$I_a =$ %
 $i =$
 Area = ac
 $d_s =$ in

Choose One
 Water Quality Capture Volume (WQCV)
 Excess Urban Runoff Volume (EURV)

$V_{DESIGN} =$ ac-ft
 $V_{DESIGN\ OTHER} =$ ac-ft
 $V_{DESIGN\ USER} =$ ac-ft

$HSG_A =$ %
 $HSG_B =$ %
 $HSG_{C/D} =$ %

$EURV_{DESIGN} =$ ac-ft
 $EURV_{DESIGN\ USER} =$ ac-ft

2. Basin Shape: Length to Width Ratio
(A basin length to width ratio of at least 2:1 will improve TSS reduction.)

$L : W =$: 1

FSD-1 USES VERTICAL WALLS

3. Basin Side Slopes

A) Basin Maximum Side Slopes
(Horizontal distance per unit vertical, 4:1 or flatter preferred)

$Z =$ ft / ft **TOO STEEP (< 3)**

4. Inlet

A) Describe means of providing energy dissipation at concentrated inflow locations:

Forebays (Sheet 1 has been included twice, one for each forebay design; designated South Forebay and North Forebay)

5. Forebay

A) Minimum Forebay Volume
($V_{MIN} =$ of the WQCV)

B) Actual Forebay Volume

C) Forebay Depth
($D_F =$ inch maximum)

D) Forebay Discharge

i) Undetained 100-year Peak Discharge

ii) Forebay Discharge Design Flow
($Q_F = 0.02 * Q_{100}$)

E) Forebay Discharge Design

F) Discharge Pipe Size (minimum 8-inches)

G) Rectangular Notch Width

NORTH FOREBAY

$V_{MIN} =$ ac-ft
 $V_F =$ ac-ft
 $D_F =$ in
 $Q_{100} =$ cfs
 $Q_F =$ cfs

Choose One
 Berm With Pipe
 Wall with Rect. Notch
 Wall with V-Notch Weir

Flow too small for berm w/ pipe

Calculated $D_P =$ in
 Calculated $W_N =$ in

Design Procedure Form: Extended Detention Basin (EDB)

UD-BMP (Version 3.07, March 2018)

Sheet 1 of 3

Designer: DDJ
Company: Galloway
Date: June 2, 2023
Project: Constitution Storage
Location: _____

1. Basin Storage Volume

A) Effective Imperviousness of Tributary Area, I_a

B) Tributary Area's Imperviousness Ratio ($i = I_a / 100$)

C) Contributing Watershed Area

D) For Watersheds Outside of the Denver Region, Depth of Average Runoff Producing Storm

E) Design Concept
(Select EURV when also designing for flood control)

F) Design Volume (WQCV) Based on 40-hour Drain Time
($V_{DESIGN} = (1.0 * (0.91 * i^3 - 1.19 * i^2 + 0.78 * i) / 12 * Area)$)

G) For Watersheds Outside of the Denver Region, Water Quality Capture Volume (WQCV) Design Volume
($V_{WQCV\ OTHER} = (d_6 * V_{DESIGN} / 0.43)$)

H) User Input of Water Quality Capture Volume (WQCV) Design Volume
(Only if a different WQCV Design Volume is desired)

I) NRCS Hydrologic Soil Groups of Tributary Watershed
 i) Percentage of Watershed consisting of Type A Soils
 ii) Percentage of Watershed consisting of Type B Soils
 iii) Percentage of Watershed consisting of Type C/D Soils

J) Excess Urban Runoff Volume (EURV) Design Volume
 For HSG A: $EURV_A = 1.68 * i^{1.28}$
 For HSG B: $EURV_B = 1.36 * i^{1.08}$
 For HSG C/D: $EURV_{C/D} = 1.20 * i^{1.08}$

K) User Input of Excess Urban Runoff Volume (EURV) Design Volume
(Only if a different EURV Design Volume is desired)

$I_a =$ %
 $i =$
 Area = ac
 $d_6 =$ in

Choose One
 Water Quality Capture Volume (WQCV)
 Excess Urban Runoff Volume (EURV)

$V_{DESIGN} =$ ac-ft
 $V_{DESIGN\ OTHER} =$ ac-ft
 $V_{DESIGN\ USER} =$ ac-ft

$HSG_A =$ %
 $HSG_B =$ %
 $HSG_{C/D} =$ %

$EURV_{DESIGN} =$ ac-ft
 $EURV_{DESIGN\ USER} =$ ac-ft

2. Basin Shape: Length to Width Ratio
(A basin length to width ratio of at least 2:1 will improve TSS reduction.)

$L : W =$: 1

FSD-1 USES VERTICAL WALLS

3. Basin Side Slopes

A) Basin Maximum Side Slopes
(Horizontal distance per unit vertical, 4:1 or flatter preferred)

$Z =$ ft / ft **TOO STEEP (< 3)**

4. Inlet

A) Describe means of providing energy dissipation at concentrated inflow locations:

Forebays (Sheet 1 has been included twice, one for each forebay design; designated South Forebay and North Forebay)

5. Forebay

A) Minimum Forebay Volume
($V_{MIN} =$ 2% of the WQCV)

B) Actual Forebay Volume

C) Forebay Depth
($D_F =$ 18 inch maximum)

D) Forebay Discharge

i) Undetained 100-year Peak Discharge

ii) Forebay Discharge Design Flow
($Q_F = 0.02 * Q_{100}$)

E) Forebay Discharge Design

F) Discharge Pipe Size (minimum 8-inches)

G) Rectangular Notch Width

SOUTH FOREBAY

$V_{MIN} =$ ac-ft
 $V_F =$ ac-ft
 $D_F =$ in
 $Q_{100} =$ cfs
 $Q_F =$ cfs

Choose One
 Berm With Pipe
 Wall with Rect. Notch
 Wall with V-Notch Weir

Flow too small for berm w/ pipe

Calculated $D_P =$ in
 Calculated $W_N =$ in

Design Procedure Form: Extended Detention Basin (EDB)

Designer: DDJ
Company: Galloway
Date: June 2, 2023
Project: Constitution Storage
Location: _____

<p>6. Trickle Channel</p> <p>A) Type of Trickle Channel</p> <p>F) Slope of Trickle Channel</p>	<div style="border: 1px solid black; padding: 5px; margin-bottom: 10px;"> Choose One <input checked="" type="radio"/> Concrete <input type="radio"/> Soft Bottom </div> <p>S = <input type="text" value="0.0050"/> ft / ft</p>
<p>7. Micropool and Outlet Structure</p> <p>A) Depth of Micropool (2.5-foot minimum)</p> <p>B) Surface Area of Micropool (10 ft² minimum)</p> <p>C) Outlet Type</p> <p>D) Smallest Dimension of Orifice Opening Based on Hydrograph Routing (Use UD-Detention)</p> <p>E) Total Outlet Area</p>	<p>D_M = <input type="text" value="2.5"/> ft</p> <p>A_M = <input type="text" value="35"/> sq ft</p> <div style="border: 1px solid black; padding: 5px; margin-bottom: 10px;"> Choose One <input checked="" type="radio"/> Orifice Plate <input type="radio"/> Other (Describe): _____ </div> <hr/> <p>D_{orifice} = <input type="text" value="0.63"/> inches</p> <p>A_{orifice} = <input type="text" value="0.93"/> square inches</p>
<p>8. Initial Surcharge Volume</p> <p>A) Depth of Initial Surcharge Volume (Minimum recommended depth is 4 inches)</p> <p>B) Minimum Initial Surcharge Volume (Minimum volume of 0.3% of the WQCV)</p> <p>C) Initial Surcharge Provided Above Micropool</p>	<p>D_{IS} = <input type="text" value="4"/> in</p> <p>V_{IS} = <input type="text"/> cu ft</p> <p>V_s = <input type="text" value="11.7"/> cu ft</p>
<p>9. Trash Rack</p> <p>A) Water Quality Screen Open Area: $A_t = A_{ot} * 38.5 * (e^{-0.095D})$</p> <p>B) Type of Screen (If specifying an alternative to the materials recommended in the USDCM, indicate "other" and enter the ratio of the total open are to the total screen are for the material specified.)</p> <p style="text-align: right;">Other (Y/N): <input type="text" value="N"/></p> <p>C) Ratio of Total Open Area to Total Area (only for type 'Other')</p> <p>D) Total Water Quality Screen Area (based on screen type)</p> <p>E) Depth of Design Volume (EURV or WQCV) (Based on design concept chosen under 1E)</p> <p>F) Height of Water Quality Screen (H_{TR})</p> <p>G) Width of Water Quality Screen Opening (W_{opening}) (Minimum of 12 inches is recommended)</p>	<p>A_t = <input type="text" value="34"/> square inches</p> <div style="border: 1px solid black; padding: 2px; margin-bottom: 10px; text-align: center;"> <i>S.S. Well Screen with 60% Open Area</i> </div> <hr/> <p>User Ratio = <input type="text"/></p> <p>A_{total} = <input type="text" value="56"/> sq. in.</p> <p>H = <input type="text" value="1.56"/> feet</p> <p>H_{TR} = <input type="text" value="46.72"/> inches</p> <p>W_{opening} = <input type="text" value="12.0"/> inches VALUE LESS THAN RECOMMENDED MIN. WIDTH. WIDTH HAS BEEN SET TO 12 INCHES.</p>

Design Procedure Form: Extended Detention Basin (EDB)

Sheet 3 of 3

Designer: DDJ
Company: Galloway
Date: June 2, 2023
Project: Constitution Storage
Location: _____

<p>10. Overflow Embankment</p> <p>A) Describe embankment protection for 100-year and greater overtopping:</p> <p>B) Slope of Overflow Embankment (Horizontal distance per unit vertical, 4:1 or flatter preferred)</p>	<p>_____</p> <p>_____</p> <p>_____</p> <p>Ze = 16.67 ft / ft</p>
<p>11. Vegetation</p>	<div style="border: 1px solid black; padding: 5px;"> <p>Choose One</p> <p><input type="radio"/> Irrigated</p> <p><input type="radio"/> Not Irrigated</p> </div>
<p>12. Access</p> <p>A) Describe Sediment Removal Procedures</p>	<p>_____</p> <p>_____</p> <p>_____</p> <p>_____</p> <p>_____</p>
<p>Notes: _____</p> <p>_____</p> <p>_____</p> <p>_____</p>	

Stormwater Detention and Infiltration Design Data Sheet

Workbook Protected

Worksheet Protected

Stormwater Facility Name: Private FSD Pond - Constitution Storage

Facility Location & Jurisdiction: 2460 Canada Dr; Colorado Springs, CO 80915 Sand Creek Basin - El Paso County

User Input: Watershed Characteristics

Watershed Slope = ft/ft
 Watershed Length = ft
 Watershed Area = acres
 Watershed Imperviousness = percent
 Percentage Hydrologic Soil Group A = percent
 Percentage Hydrologic Soil Group B = percent
 Percentage Hydrologic Soil Groups C/D = percent

Location for 1-hr Rainfall Depths (use dropdown):

User Input ▼

WQCV Treatment Method = ▼

User Defined Stage [ft]	User Defined Area [ft^2]	User Defined Stage [ft]	User Defined Discharge [cfs]
0.00	35	0.00	0.00
1.00	2,555	1.00	0.02
1.52	5,663	1.52	0.03
2.00	7,777	2.00	0.06
3.00	9,210	3.00	0.10
3.25	9,263	3.25	0.62
3.40	9,295	3.40	3.58
4.00	9,423	4.00	3.58
5.00	9,604	5.00	3.58
6.00	9,713	6.00	3.58

After completing and printing this worksheet to a pdf, go to: <https://maperture.digitaldataservices.com/gvh/?viewer=cswdif> create a new stormwater facility, and attach the pdf of this worksheet to that record.

Routed Hydrograph Results

	WQCV	2 Year	5 Year	10 Year	50 Year	100 Year	
Design Storm Return Period =							
One-Hour Rainfall Depth =	0.60	0.99	1.27	1.53	2.29	2.67	in
Calculated Runoff Volume =	0.074	0.165	0.218	0.273	0.443	0.540	acre-ft
OPTIONAL Override Runoff Volume =							acre-ft
Inflow Hydrograph Volume =	0.073	0.164	0.218	0.272	0.443	0.540	acre-ft
Time to Drain 97% of Inflow Volume =	47.5	66.0	72.9	79.0	87.4	85.1	hours
Time to Drain 99% of Inflow Volume =	51.9	72.4	80.2	87.2	97.8	96.4	hours
Maximum Ponding Depth =	1.44	2.02	2.30	2.57	3.23	3.36	ft
Maximum Poned Area =	0.12	0.18	0.19	0.20	0.21	0.21	acres
Maximum Volume Stored =	0.068	0.155	0.206	0.260	0.396	0.422	acre-ft

Stormwater Detention and Infiltration Design Data Sheet

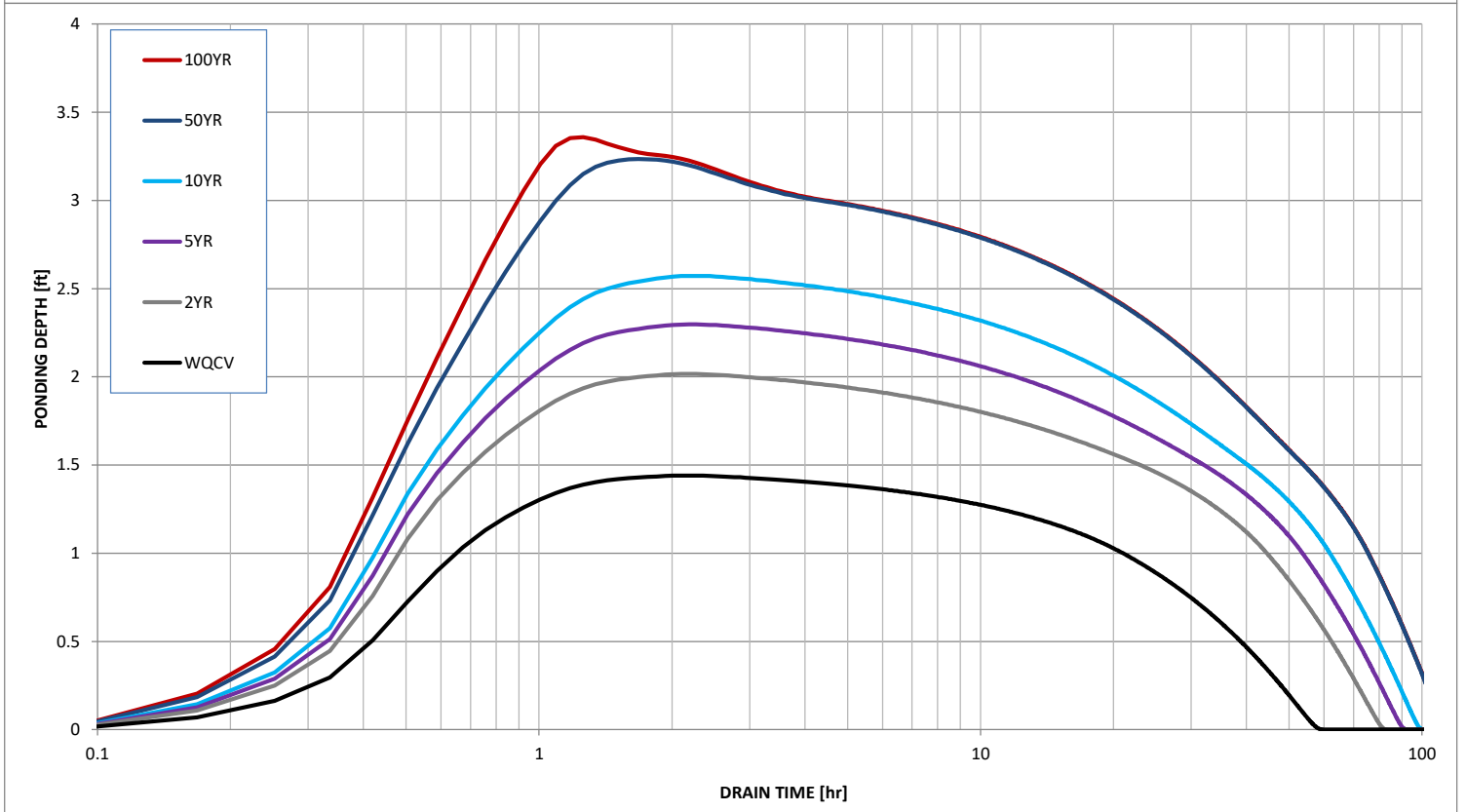
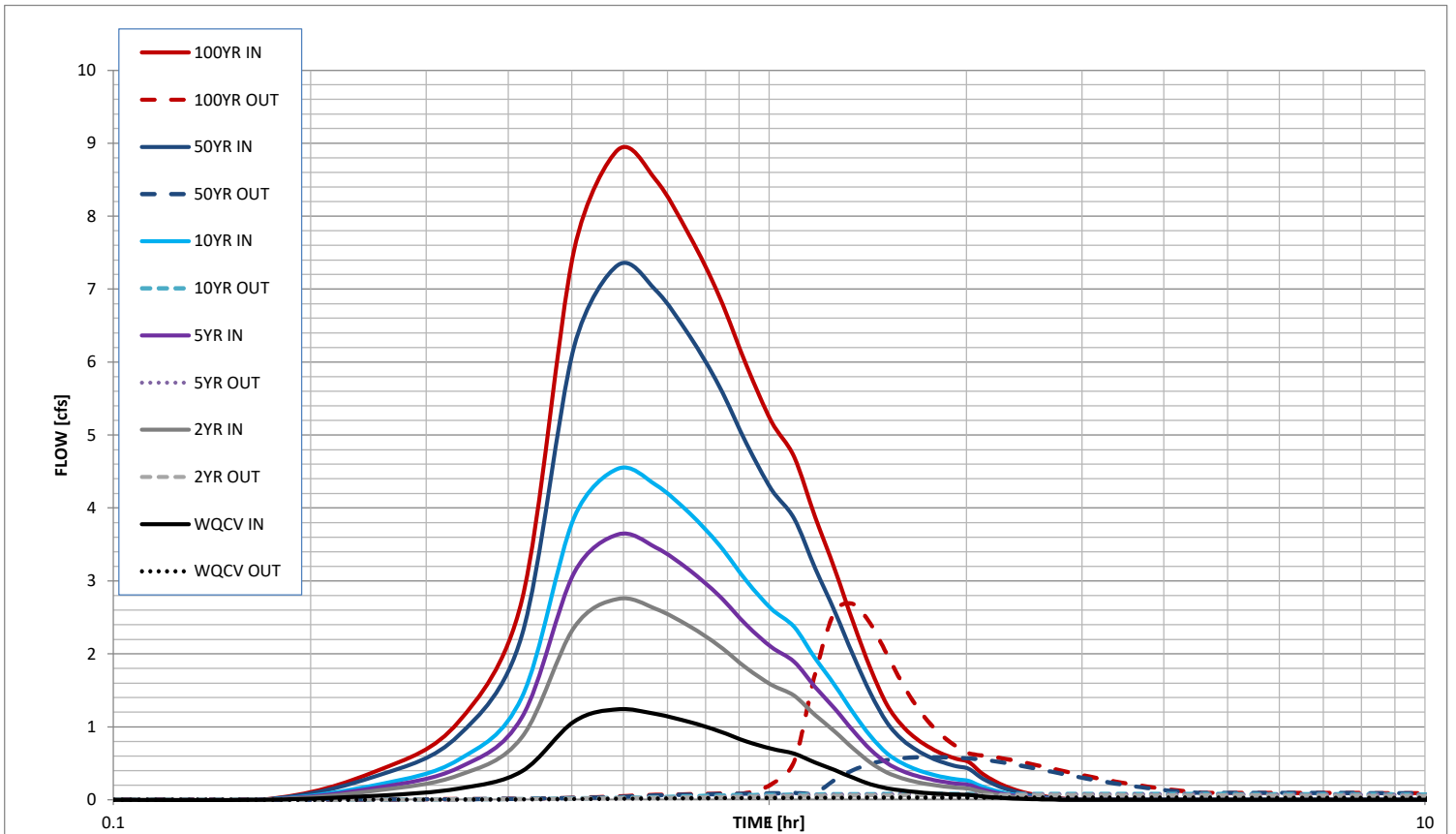

APPENDIX E

Drainage Maps

6805 BISMARCK RD COLORADO SPRINGS CO, 80922-1116

LAND USE: CODE 200 AT PRESENT WORTH
PLAT NO: 7776
4432 SLICE DR COLORADO SPRINGS CO, 80922

K & S DEVELOPMENT LLC
PARCEL NO: 5332309004
ZONE: CC CAD-0
LAND USE: CODE 200 AT PRESENT WORTH
PLAT NO: 7776
4432 SLICE DR COLORADO SPRINGS CO, 80922

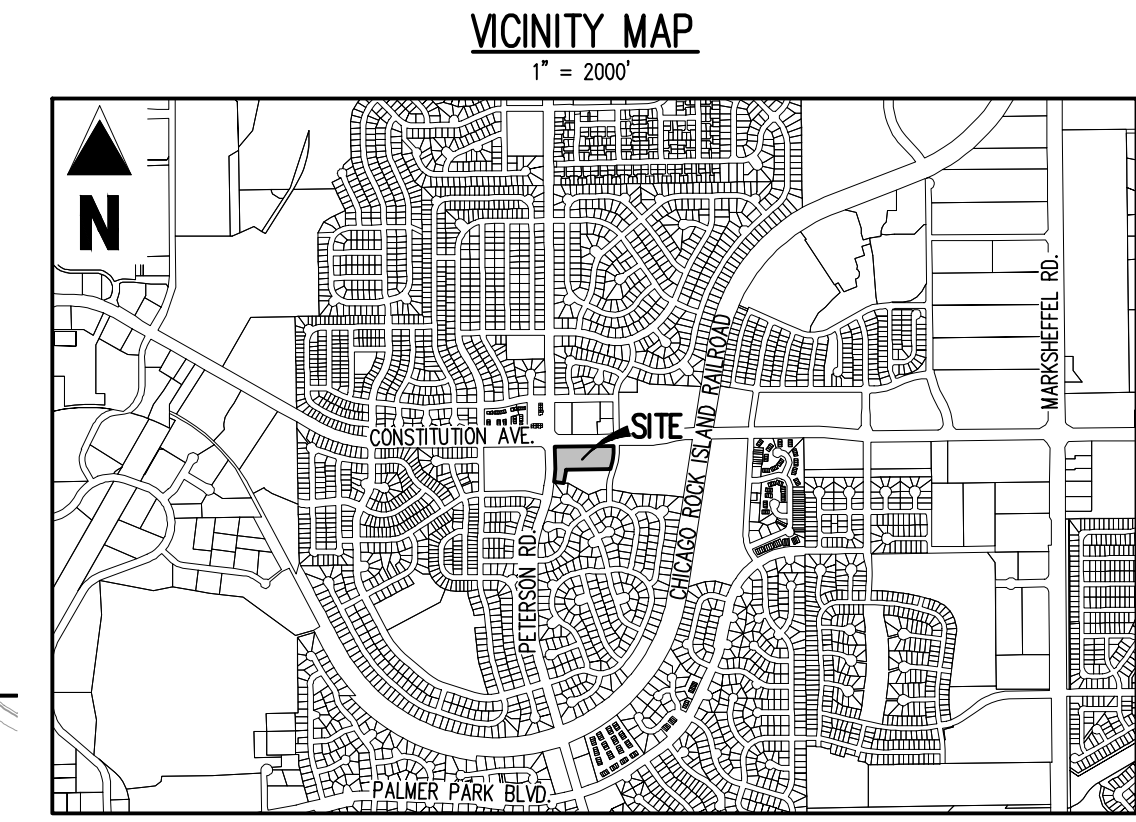
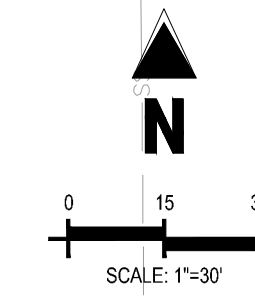

Galloway

6162 S. Willow Drive, Suite 320
Greenwood Village, CO 80111
303.770.8884
gallowayus.com

PRELIMINARY
NOT FOR BIDDING
NOT FOR CONSTRUCTION

COPYRIGHT
THESE PLANS ARE AN INSTRUMENT OF SERVICE AND ARE THE PROPERTY OF GALLOWAY, AND MAY NOT BE DUPLICATED, DISCLOSED, OR REPRODUCED WITHOUT THE WRITTEN CONSENT OF GALLOWAY. COPYRIGHTS AND INFRINGEMENTS WILL BE ENFORCED AND PROSECUTED.



CONSTITUTION AVENUE
120' PUBLIC RIGHT OF WAY

5' PUBLIC UTILITY EASEMENT
REC. 1445775

SIGN PED. CROSSING
SET NAIL WITH 1-1/2" ALUMINUM DISC STAMPED "PLS 38069"

EX-4

EX-5

EX-6

EX-3

EX-2

EX-1

5' PUBLIC UTILITY AND DRAINAGE EASEMENT
REC. 1445775

EIGHT LINE INC.
PARCEL NO: 5405218003
ZONE: CC CAD-0
LAND USE: SPECIAL PURPOSE
PLAT NO: 9808
8300 S COUNTY LINE RD OKLAHOMA CITY OK, 73169-1606

ALVARADO KIMBERLY AI
PARCEL NO: 5405218010
ZONE: RS-6000 CAD-0
LAND USE: SINGLE FAMILY RES.
PLAT NO: 6430
5365 ALLYN WAY COLORADO SPRINGS CO, 80915-4230

OPSAHL LEV
PARCEL NO: 5405218009
ZONE: RS-6000 CAD-0
LAND USE: SINGLE FAMILY RES.

JASPERCO LLC
PARCEL NO: 5405218002
ZONE: RM-30
LAND USE: SPECIAL PURPOSE
PLAT NO: 9808
5532 SADDLE ROCK TRL COLORADO SPRINGS CO, 80918-3006

SINGLE STORY WOOD RESIDENCE
F.F.: 6502.08

10' X 20' CARPORT

UTILITY EASEMENT
REC. 98070659

GATE (SITE ACCESS)

CANADA DRIVE
60' PUBLIC RIGHT OF WAY

DRAINAGE LEGEND

- - - - - EXISTING PROPERTY LINE
- - - - - EXISTING MAJOR CONTOUR
- - - - - EXISTING MINOR CONTOUR
- - - - - PROPOSED ROAD CENTERLINE
- - - - - TIME OF CONCENTRATION PATH
- - - - - BASIN BOUNDARY LINE
- - - - - EXISTING STORM SEWER
- PROPOSED STORM STRUCTURES
- BASIN DESIGNATION
- 5-YEAR RUNOFF IN CUBIC FEET PER SECOND
- 100-YEAR RUNOFF IN CUBIC FEET PER SECOND
- BASIN AREA IN ACRES
- △ DESIGN POINT
- DIRECTION OF RUNOFF

Tributary Sub-basin	Area (acres)	Cs	C100	t _c (min)	Q _c (cfs)	Q ₁₀₀ (cfs)
EX-1	0.05	0.00	0.22	5.25	0.0	0.1
EX-2	0.26	0.00	0.22	11.28	0.0	0.4
EX-3	0.39	0.03	0.25	11.17	0.0	0.7
EX-4	0.03	0.53	0.63	5.00	0.1	0.2
EX-5	2.69	0.05	0.27	11.67	0.4	4.8
EX-6	0.36	0.00	0.22	11.11	0.0	0.5

CONSTITUTION STORAGE
COMMERCIAL DEVELOPMENT
DRAINAGE MAP
FOR JOHNSON DEVELOPMENT ASSOCIATES

LOT 1 OF THE EIGHT LINE SUBDIVISION
COLORADO SPRINGS, CO 80915

#	Date	Issue / Description	Init.

Project No: JDA02.20
Drawn By: BAS
Checked By: BAS
Date: 07.08.2022

EXISTING DRAINAGE MAP

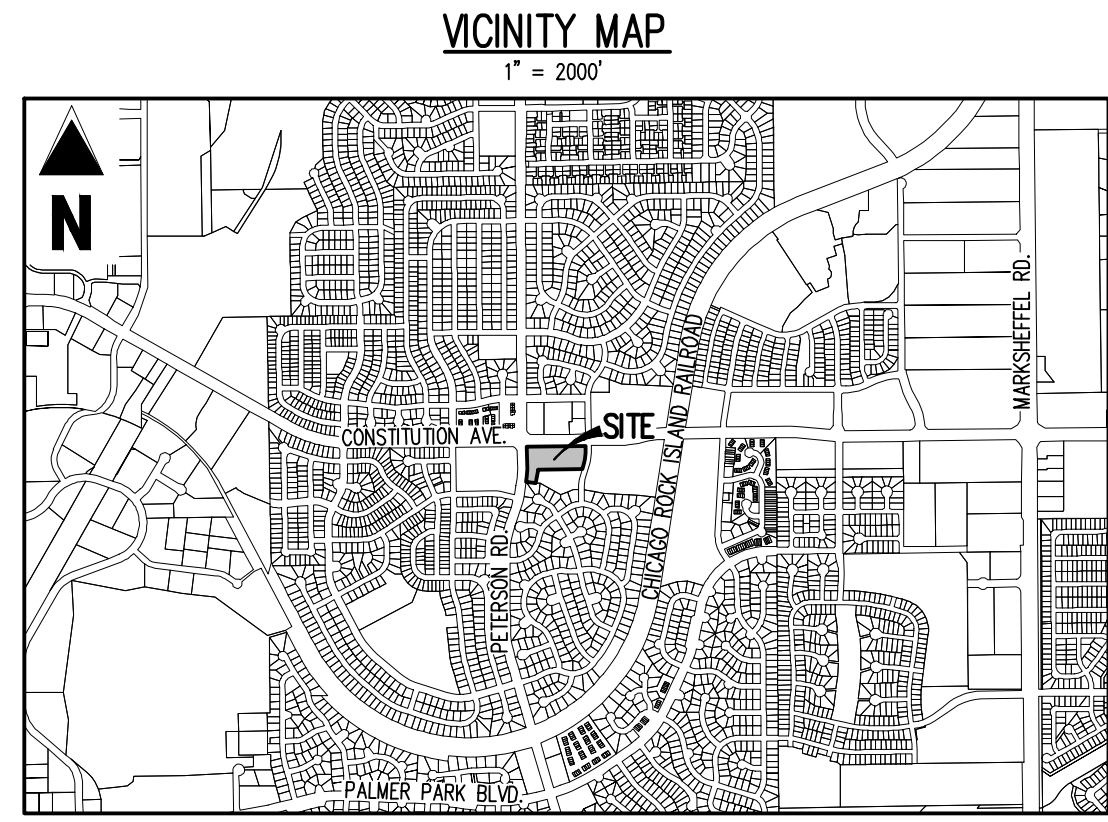
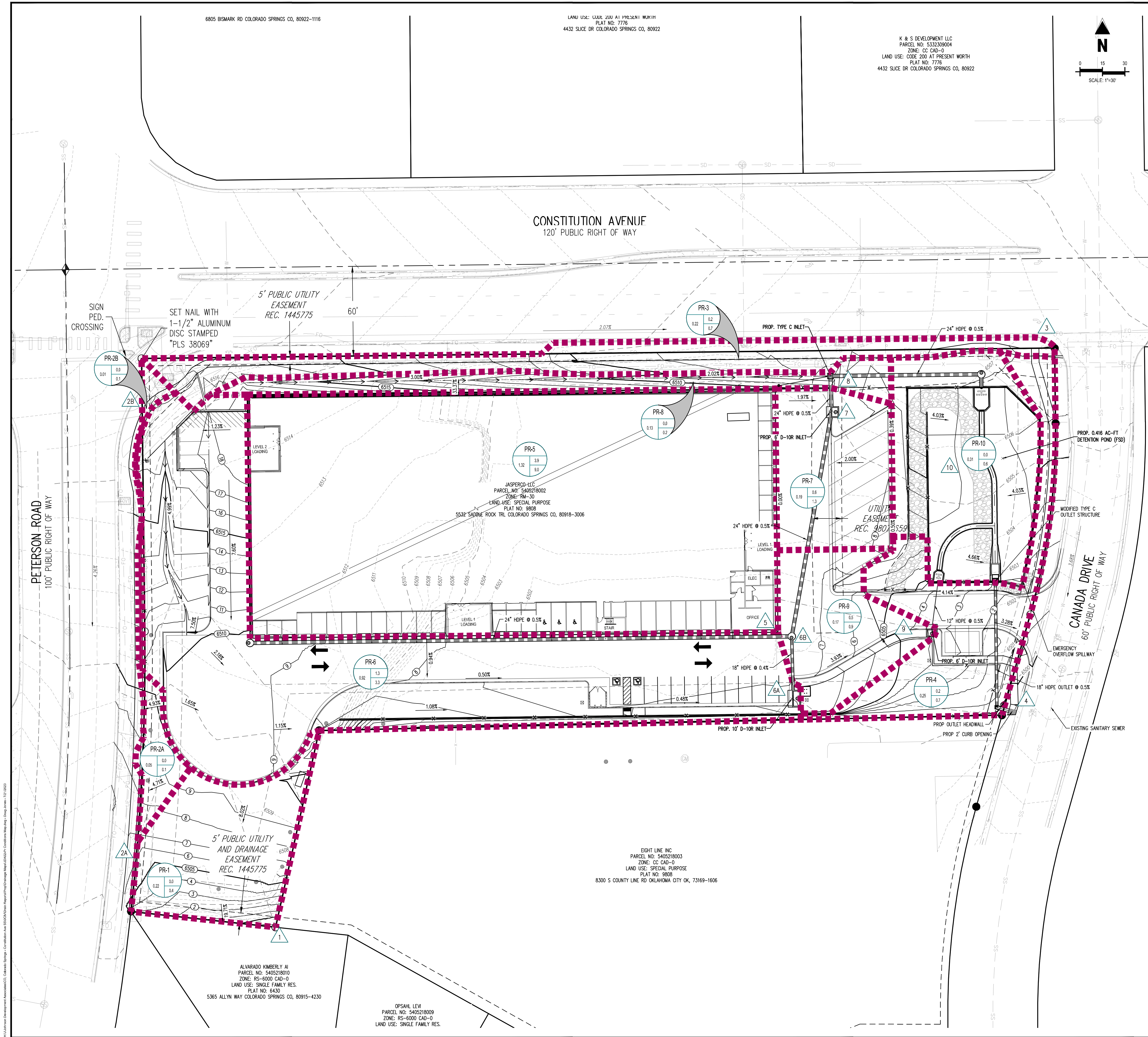

DRAINAGE LEGEND

- EXISTING PROPERTY LINE
- EXISTING MAJOR CONTOUR
- EXISTING MINOR CONTOUR
- PROPOSED MAJOR CONTOUR
- PROPOSED MINOR CONTOUR
- TIME OF CONCENTRATION PATH
- BASIN BOUNDARY LINE
- EXISTING STORM SEWER
- PROPOSED STORM STRUCTURES
- BASIN DESIGNATION
- 5-YEAR RUNOFF IN CUBIC FEET PER SECOND
- 100-YEAR RUNOFF IN CUBIC FEET PER SECOND
- BASIN AREA IN ACRES
- DESIGN POINT
- DIRECTION OF RUNOFF

BASIN SUMMARY TABLE						
Tributary Sub-basin	Area (acres)	Cs	C100	tc (min)	Qs (cfs)	Q100 (cfs)
PR-1	0.22	0.00	0.22	9.4	0.0	0.4
PR-2A	0.05	0.10	0.30	9.0	0.0	0.1
PR-2B	0.01	0.53	0.63	5.0	0.0	0.1
PR-3	0.22	0.20	0.38	5.0	0.2	0.7
PR-4	0.25	0.23	0.40	8.5	0.2	0.7
PR-5	1.32	0.71	0.79	5.0	3.9	9.0
PR-6	0.92	0.44	0.55	11.6	1.3	3.3
PR-7	0.19	0.74	0.81	5.0	0.6	1.3
PR-8	0.13	0.00	0.22	10.0	0.0	0.2
PR-9	0.17	0.54	0.64	6.6	0.5	0.9
PR-10	0.31	0.00	0.22	5.0	0.0	0.6
<i>Routed Flow to FSD (DP-10)</i>					4.9	12.5
<i>Total Offsite Free-Release (PR-1, PR-2A, PR-2B, PR-3, PR-4)</i>					0.4	2.0

DESIGN POINT SUMMARY TABLE		
Design Point	Routed Flows	
	Qs (cfs)	Q100 (cfs)
1	0.0	0.4
2A	0.0	0.1
2B	0.0	0.1
3	0.2	0.7
4	0.2	0.7
5	3.9	9.0
6A	1.2	3.3
6B	4.2	10.1
7	4.6	11.1
8	4.6	11.3
9	0.3	0.9
10	4.9	12.5

Galloway

6162 S. Willow Drive, Suite 320
Greenwood Village, CO 80111
303.770.8884
gallowayus.com

PRELIMINARY
 NOT FOR BIDDING
 NOT FOR CONSTRUCTION

COPYRIGHT
 THESE PLANS ARE AN INSTRUMENT OF SERVICE AND ARE THE PROPERTY OF GALLOWAY, AND MAY NOT BE DUPLICATED, DISCLOSED, OR REPRODUCED WITHOUT THE WRITTEN CONSENT OF GALLOWAY. COPYRIGHTS AND INFRINGEMENTS WILL BE ENFORCED AND PROSECUTED.

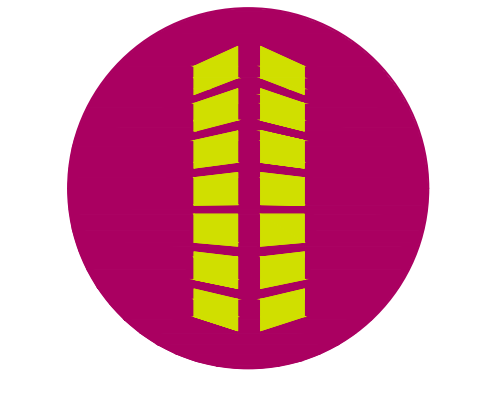

CONSTITUTION STORAGE
 COMMERCIAL DEVELOPMENT
 DRAINAGE MAP
 FOR JOHNSON DEVELOPMENT ASSOCIATES

LOT 1 OF THE EIGHT LINE SUBDIVISION
 COLORADO SPRINGS, CO 80915

#	Date	Issue / Description	Init.

Project No: JDA02.20
 Drawn By: DDJ
 Checked By: SMB
 Date: 06.07.2023

PROPOSED DRAINAGE MAP

DR-2

APPENDIX F

PCM Plans



COPYRIGHT
 THESE PLANS ARE AN INSTRUMENT OF SERVICE AND ARE THE PROPERTY OF GALLOWAY, AND MAY NOT BE DUPLICATED, DISCLOSED, OR REPRODUCED WITHOUT THE WRITTEN CONSENT OF GALLOWAY. COPYRIGHTS AND INFRINGEMENTS WILL BE ENFORCED AND PROSECUTED.



**PRIVATE PERMANENT CONTROL MEASURE PLAN
 CONSTITUTION STORAGE**
JOHNSON DEVELOPMENT ASSOCIATES
 2460 CANADA DRIVE
 COLORADO SPRINGS, CO 80915

#	Date	Issue / Description	Init.

Project No: JDA02
 Drawn By: ASA/MRK
 Checked By: BAS
 Date: JULY 2023

OVERALL PCM PLAN

PCM1.0
 Sheet 2 of 6

LEGEND

	PROPERTY LINE
	PROPOSED EASEMENT
	EXISTING EASEMENT
	PROPOSED MAJOR CONTOUR
	PROPOSED MINOR CONTOUR
	EXISTING MAJOR CONTOUR
	EXISTING MINOR CONTOUR
	PROPOSED OPAQUE LANDSCAPE FENCE
	PROPOSED SPLIT RAIL FENCE
	PROPOSED BUILDING OUTLINE
	PROPOSED CROSS PAN
	PROPOSED SIDEWALK
	PROPOSED HEAVY DUTY CONCRETE
	PROPOSED DETECTABLE WARNING SURFACE
	PROPOSED GRAVEL MAINTENANCE ACCESS
	PROPOSED RETAINING WALL
	EXISTING SIDEWALK
	EXISTING FENCE
	PROPOSED STORM PIPE
	PROPOSED STORM PIPE <12"
	EXISTING STORM PIPE
	EXISTING CURB & GUTTER
	PROPOSED CURB & GUTTER
	PROPOSED STORM DRAIN STRUCTURES
	EXISTING STORM DRAIN STRUCTURES

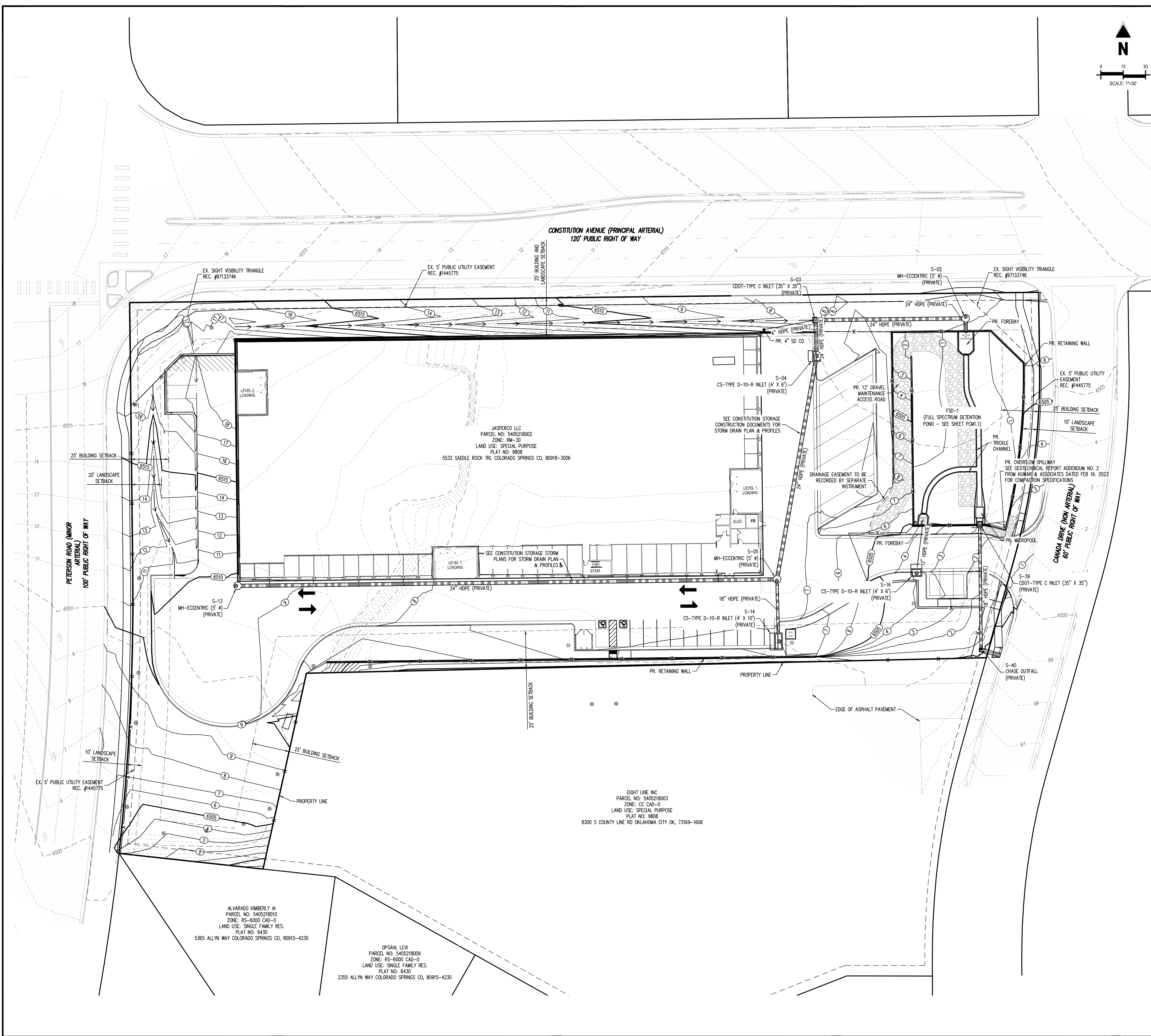
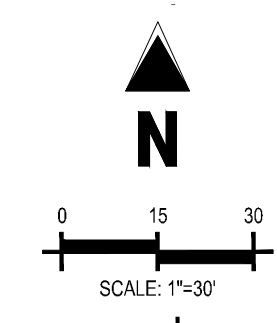

BASIS OF BEARINGS
 BASIS OF BEARING: ALL BEARINGS ARE GRID BEARINGS OF THE COLORADO STATE PLANE COORDINATE SYSTEM, CENTRAL ZONE, NORTH AMERICAN DATUM 1983. THE NORTH LINE OF THE NORTHWEST QUARTER OF SECTION 5, TOWNSHIP 14 SOUTH, RANGE 65 WEST BEARS N89°20'41"E, MONUMENTED BY THE NORTHWEST CORNER OF SAID SECTION 5, BEING A 3-1/4" ALUMINUM CAP STAMPED "PLS 4842 1985" IN RANGE BOX, AND BY THE NORTH QUARTER CORNER OF SAID SECTION 5, BEING A 3-1/4" ALUMINUM CAP STAMPED "PLS 30829 2003", AS SHOWN HEREON.

BENCHMARK
 COLORADO SPRINGS UTILITIES FACILITIES INFORMATION MANAGEMENT SYSTEM (FIMS)
 BENCHMARK SPOT BEING A 2" ALUMINUM CAP STAMPED "CSU FIMS CONTROL SPOT" AT THE SOUTHEAST CORNER OF THE CONCRETE BASE FOR AN ELECTRIC VAULT ON THE WEST SIDE OF PETERSON ROAD, ABOUT 360' SOUTH OF THE CENTER LINE OF LEOTI DRIVE.

FIMS DATUM ELEVATION = 6534.61

CAUTION - NOTICE TO CONTRACTOR
 1. ALL UTILITY LOCATIONS SHOWN ARE BASED ON MAPS PROVIDED BY THE APPROPRIATE UTILITY COMPANY AND FIELD SURFACE EVIDENCE AT THE TIME OF SURVEY AND IS TO BE CONSIDERED AN APPROXIMATE LOCATION ONLY. IT IS THE CONTRACTOR'S RESPONSIBILITY TO FIELD VERIFY THE LOCATION OF ALL UTILITIES, PUBLIC OR PRIVATE, WHETHER SHOWN ON THE PLANS OR NOT, PRIOR TO CONSTRUCTION. REPORT ANY DISCREPANCIES TO THE ENGINEER PRIOR TO CONSTRUCTION.



2. WHERE A PROPOSED UTILITY CROSSES AN EXISTING UTILITY, IT IS THE CONTRACTOR'S RESPONSIBILITY TO FIELD VERIFY THE HORIZONTAL AND VERTICAL LOCATION OF SUCH EXISTING UTILITY, EITHER THROUGH POT-HOLING OR ALTERNATIVE METHOD. REPORT INFORMATION TO THE ENGINEER PRIOR TO CONSTRUCTION.

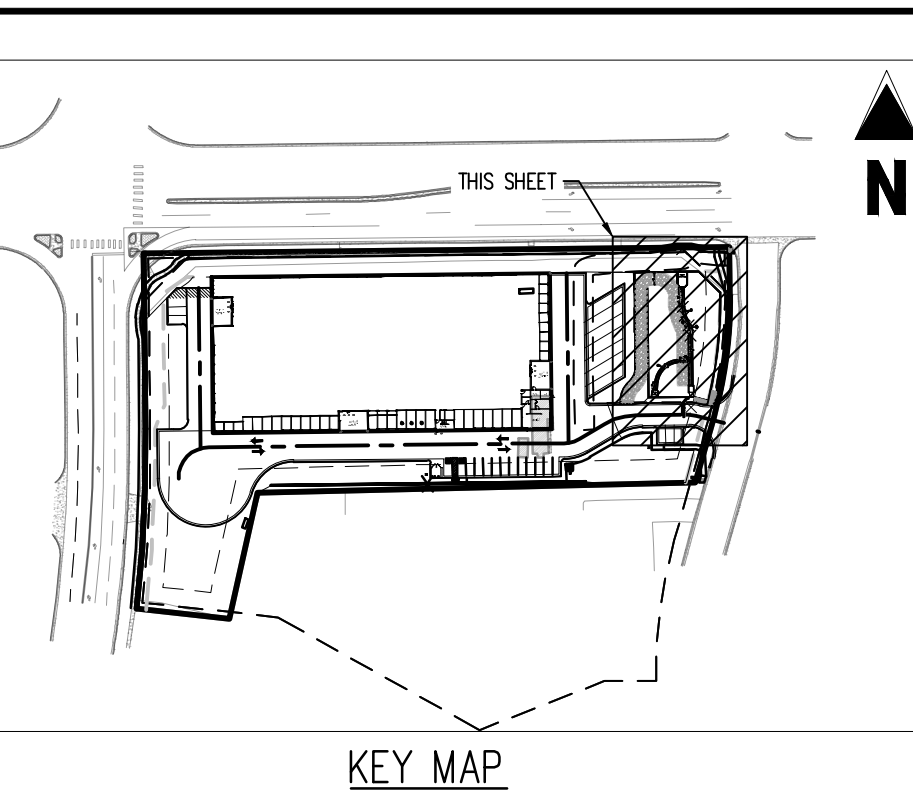
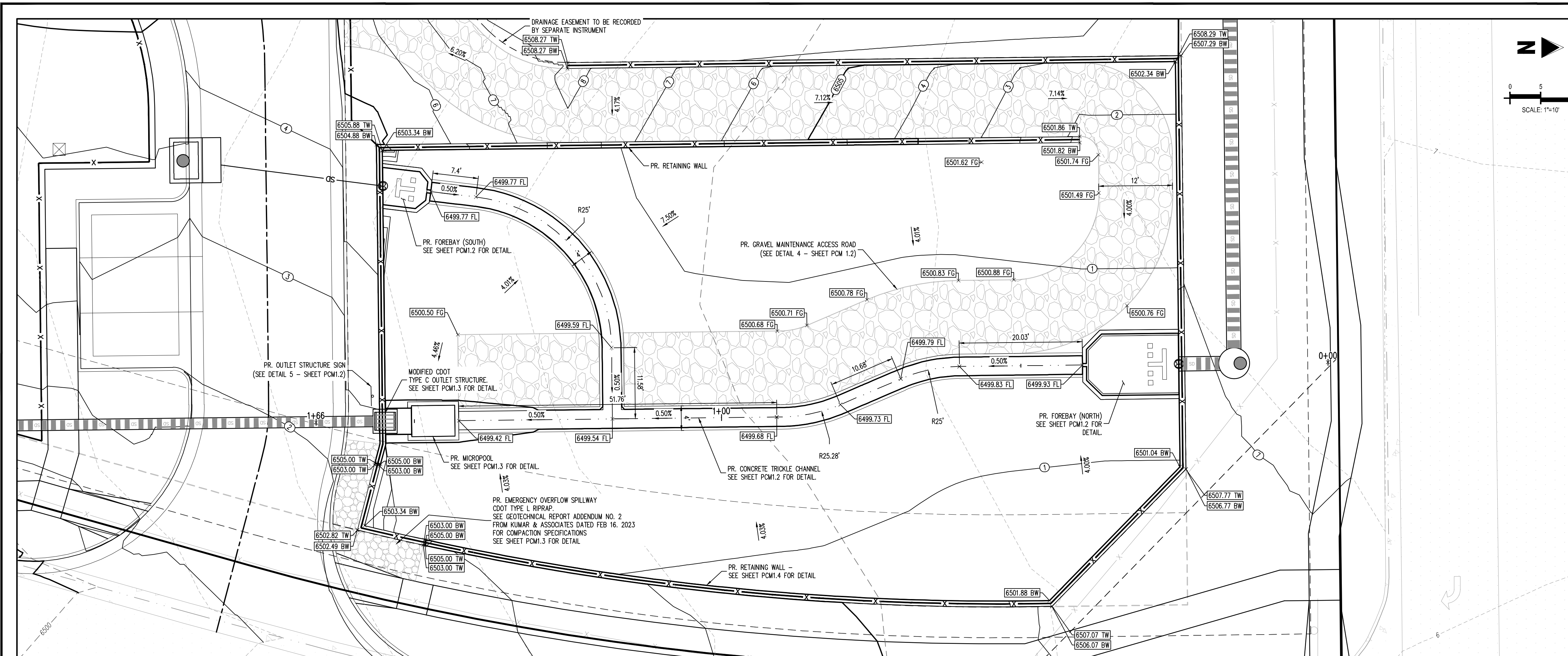

LEGEND

---	PROPERTY LINE
---	PROPOSED EASEMENT
---	EXISTING EASEMENT
---	PROPOSED MAJOR CONTOUR
---	PROPOSED MINOR CONTOUR
---	EXISTING MAJOR CONTOUR
---	EXISTING MINOR CONTOUR
---	PROPOSED TRANSPARENT LANDSCAPE FENCE
---	PROPOSED SPLIT RAIL FENCE
---	PROPOSED BUILDING OUTLINE
---	PROPOSED CROSS PAV.
---	PROPOSED SIDEWALK
---	PROPOSED HEAVY DUTY CONCRETE
---	PROPOSED DETECTABLE WARNING SURFACE
---	PROPOSED GRAVEL MAINTENANCE ACCESS
---	PROPOSED RETAINING WALL
---	EXISTING SIDEWALK
---	EXISTING FENCE
---	PROPOSED STORM PIPE
---	PROPOSED STORM PIPE <12"
---	EXISTING STORM PIPE
---	EXISTING CURB & GUTTER
---	PROPOSED CURB & GUTTER
---	PROPOSED STORM DRAIN STRUCTURES
---	EXISTING STORM DRAIN STRUCTURES

- NOTE:** SEE APPROVED DEVELOPMENT PLAN FOR THE PROPOSED LANDSCAPING PLANS FOR LANDSCAPING WITHIN THE PERMANENT BMP AREA.
- NOTE:** CONTRACTOR SHALL PROTECT ALL EXISTING SURVEY MONUMENTATION. CONTRACTOR SHALL HAVE LICENSED SURVEYOR REPLACE ANY DAMAGED OR DISTURBED MONUMENTATION AT THEIR COST.
- NOTE:** CONTRACTOR RESPONSIBLE FOR AS-BUILT DRAWINGS, TESTS, REPORTS, AND/OR ANY OTHER CERTIFICATES OF INFORMATION AS REQUIRED FOR ACCEPTANCE OF WORK FROM CITY, UTILITY DISTRICTS OR ANY OTHER GOVERNING AGENCY.
- NOTES:**
- REFER TO CONSTITUTION STORAGE PRIVATE IMPROVEMENT PLANS FOR ALL STORM PIPE, INLET, MANHOLE AND APPURTENANCE INFORMATION.
 - ALL STORM PIPE SHALL BE RCP CLASS 3 MINIMUM OR HDPE IN ACCORDANCE WITH CITY STANDARDS AND SPECIFICATIONS, UNLESS OTHERWISE NOTED. TRENCH BEDDING SHALL BE IN ACCORDANCE WITH CITY SPECIFICATIONS.
 - ALL STORMWATER FACILITIES SHOWN ON THESE PLANS ARE ASSUMED PRIVATE UNLESS OTHERWISE NOTED.
 - WALLS EXCEEDING 4' (MEASURED FROM BOTTOM OF FOOTING TO TOP OF WALL) MAY REQUIRE A BUILDING PERMIT.
 - EXISTING VEGETATION CONSISTS OF NATURAL GRASSES AND SHRUBS.
 - SOILS WITHIN THE SITE ARE TRUCKTON SANDY LOAM.
 - BOTTOM OF POND TO HAVE A MINIMUM SLOPE OF 3% TO THE TRICKLE CHANNEL AND MICROPOOL.

Galloway

1155 Kelly Johnson Blvd., Suite 305
 Colorado Springs, CO 80920
 719.900.7220
GallowayUS.com

PROFESSIONAL ENGINEER
 License No. 17/212023
 38164

COPYRIGHT
 THESE PLANS ARE AN INSTRUMENT OF SERVICE AND ARE THE PROPERTY OF GALLOWAY, AND MAY NOT BE DUPLICATED, DISCLOSED, OR REPRODUCED WITHOUT THE WRITTEN CONSENT OF GALLOWAY. COPYRIGHTS AND INFRINGEMENTS WILL BE ENFORCED AND PROSECUTED.



**PRIVATE PERMANENT CONTROL MEASURE PLAN
 CONSTITUTION STORAGE**

JOHNSON DEVELOPMENT ASSOCIATES

2460 CANADA DRIVE
 COLORADO SPRINGS, CO 80915

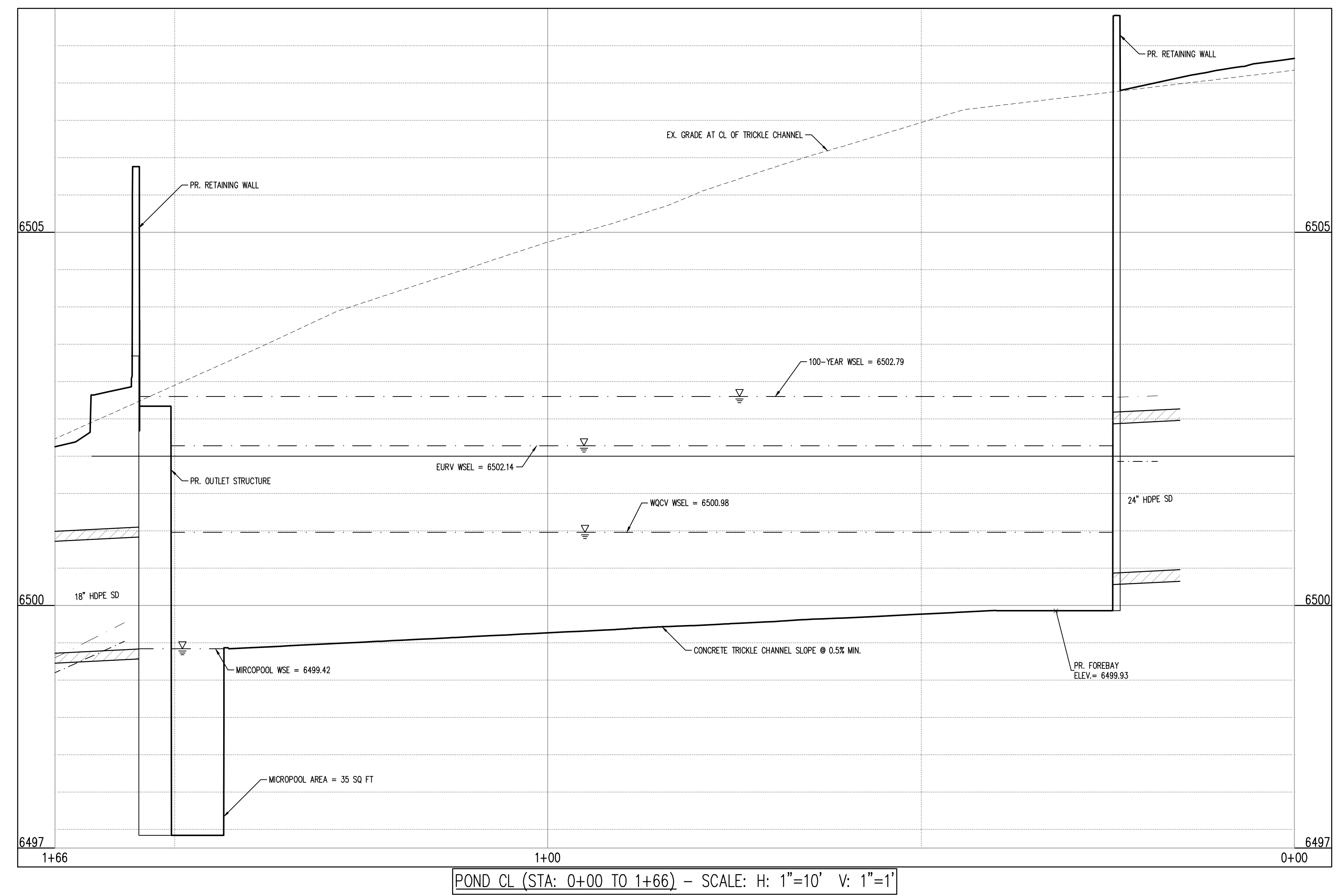

POND CL (STA: 0+00 TO 1+66) - SCALE: H: 1"=10' V: 1"=1'

- BASIS OF BEARINGS**
- BASIS OF BEARINGS: ALL BEARINGS ARE GRID BEARINGS OF THE COLORADO STATE PLANE COORDINATE SYSTEM, CENTRAL ZONE, NORTH AMERICAN DATUM 1983. THE NORTH LINE OF THE NORTHWEST QUARTER OF SECTION 5, TOWNSHIP 14 SOUTH, RANGE 65 WEST BEARS N89°20'41"E, MONUMENTED BY THE NORTHWEST CORNER OF SAID SECTION 5, BEING A 3-1/4" ALUMINUM CAP STAMPED "PLS 4842 1985" IN RANGE BOX, AND BY THE NORTH QUARTER CORNER OF SAID SECTION 5, BEING A 3-1/4" ALUMINUM CAP STAMPED "PLS 30829 2003", AS SHOWN HEREON.
- BENCHMARK**
- COLORADO SPRINGS UTILITIES FACILITIES INFORMATION MANAGEMENT SYSTEM (FIMS)
 BENCHMARK SRO7 BEING A 2" ALUMINUM CAP STAMPED "CSU FIMS CONTROL SRO7" AT THE SOUTHWEST CORNER OF THE CONCRETE BASE FOR AN ELECTRIC VAULT ON THE WEST SIDE OF PETERSON ROAD, ABOUT 360' SOUTH OF THE CENTER LINE OF LEOTI DRIVE.
- FIMS DATUM ELEVATION = 6534.61
- CAUTION - NOTICE TO CONTRACTOR**
- ALL UTILITY LOCATIONS SHOWN ARE BASED ON MAPS PROVIDED BY THE APPROPRIATE UTILITY COMPANY AND FIELD SURFACE EVIDENCE AT THE TIME OF SURVEY AND IS TO BE CONSIDERED AN APPROXIMATE LOCATION ONLY. IT IS THE CONTRACTOR'S RESPONSIBILITY TO FIELD VERIFY THE LOCATION OF ALL UTILITIES, PUBLIC OR PRIVATE, WHETHER SHOWN ON THE PLANS OR NOT, PRIOR TO CONSTRUCTION. REPORT ANY DISCREPANCIES TO THE ENGINEER PRIOR TO CONSTRUCTION.
 - WHERE A PROPOSED UTILITY CROSSES AN EXISTING UTILITY, IT IS THE CONTRACTOR'S RESPONSIBILITY TO FIELD VERIFY THE HORIZONTAL AND VERTICAL LOCATION OF SUCH EXISTING UTILITY, EITHER THROUGH POT-HOLES OR ALTERNATIVE METHOD. REPORT INFORMATION TO THE ENGINEER PRIOR TO CONSTRUCTION.

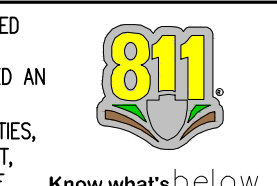

#	Date	Issue / Description	Init.

Project No: JDA02
 Drawn By: ASA/MRK
 Checked By: BAS
 Date: JULY 2023

POND PLAN

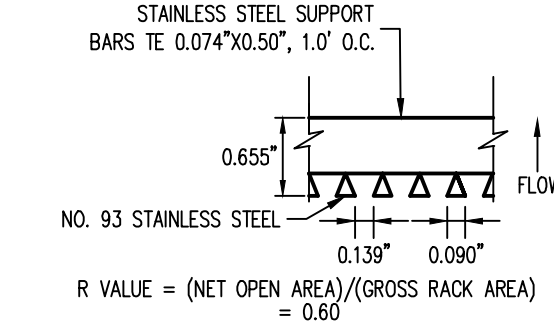
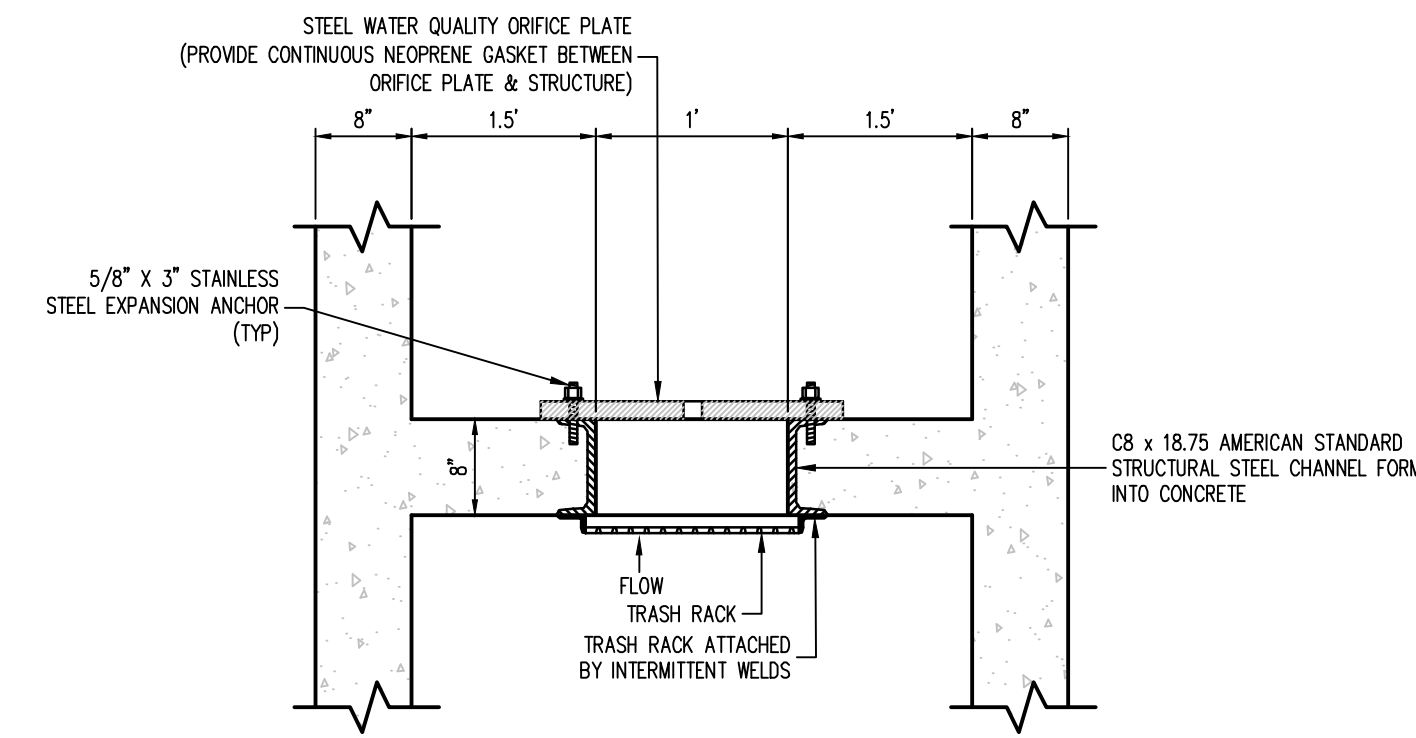
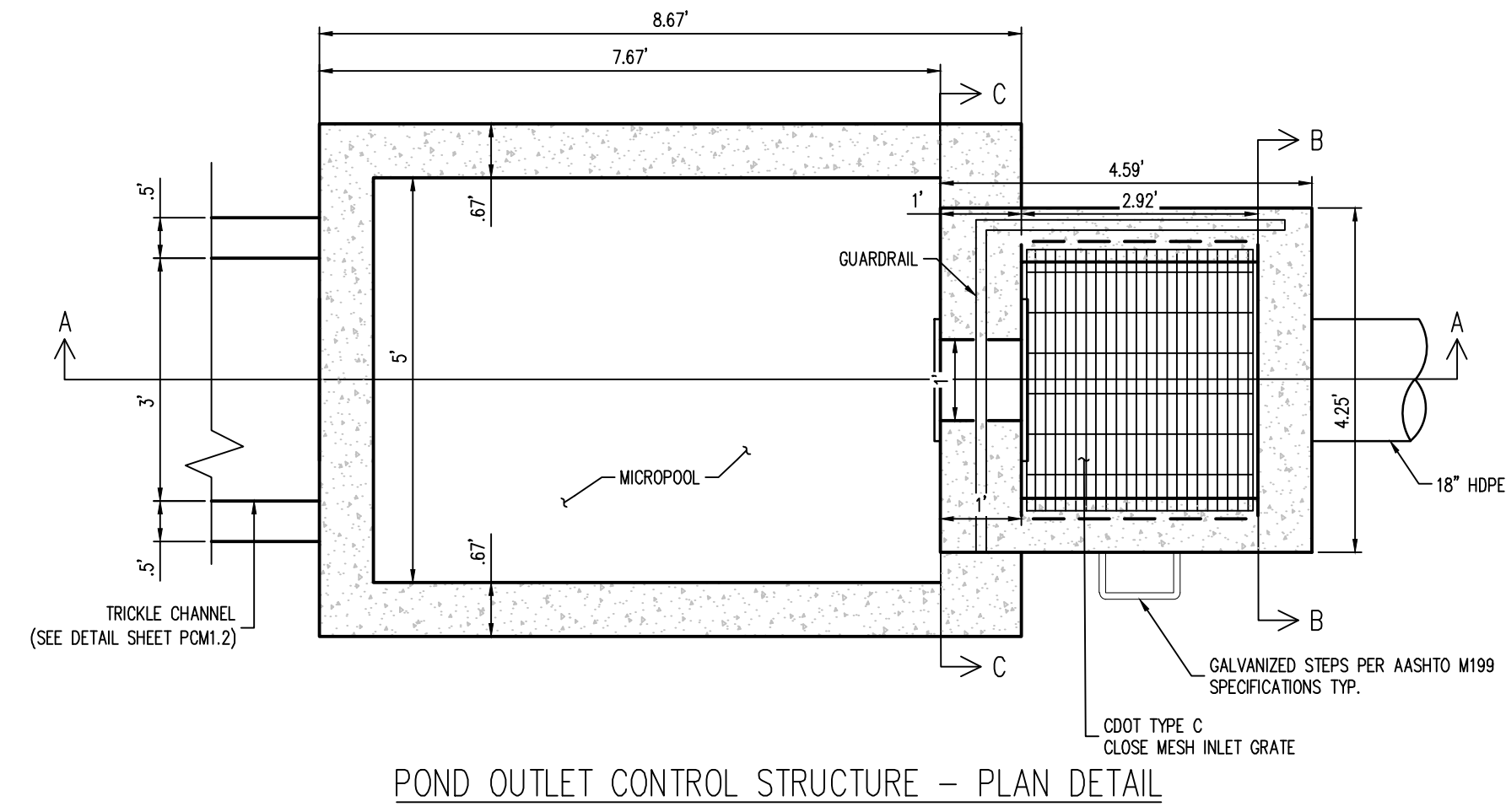

POND OUTLET CONTROL STRUCTURE - PLAN DETAIL

SECTION D-D
NOT TO SCALE

TRASH RACK SECTION
SCALE: 1" = 1'

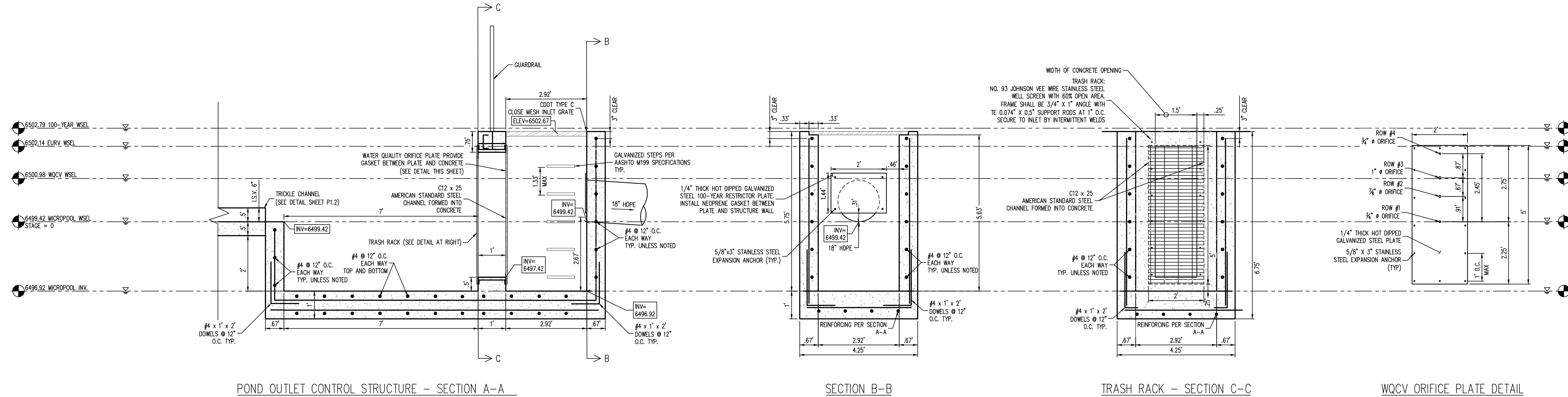

POND OUTLET CONTROL STRUCTURE - SECTION A-A

SECTION B-B

TRASH RACK - SECTION C-C

WQCV ORIFICE PLATE DETAIL

1 POND OUTLET STRUCTURE
SCALE: 1" = 2'

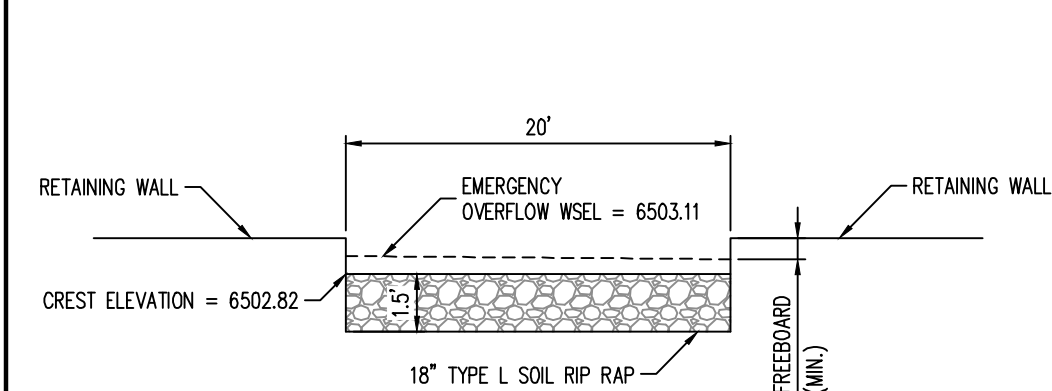

2 POND 100-YEAR OVERFLOW - CROSS SECTION
NOT TO SCALE

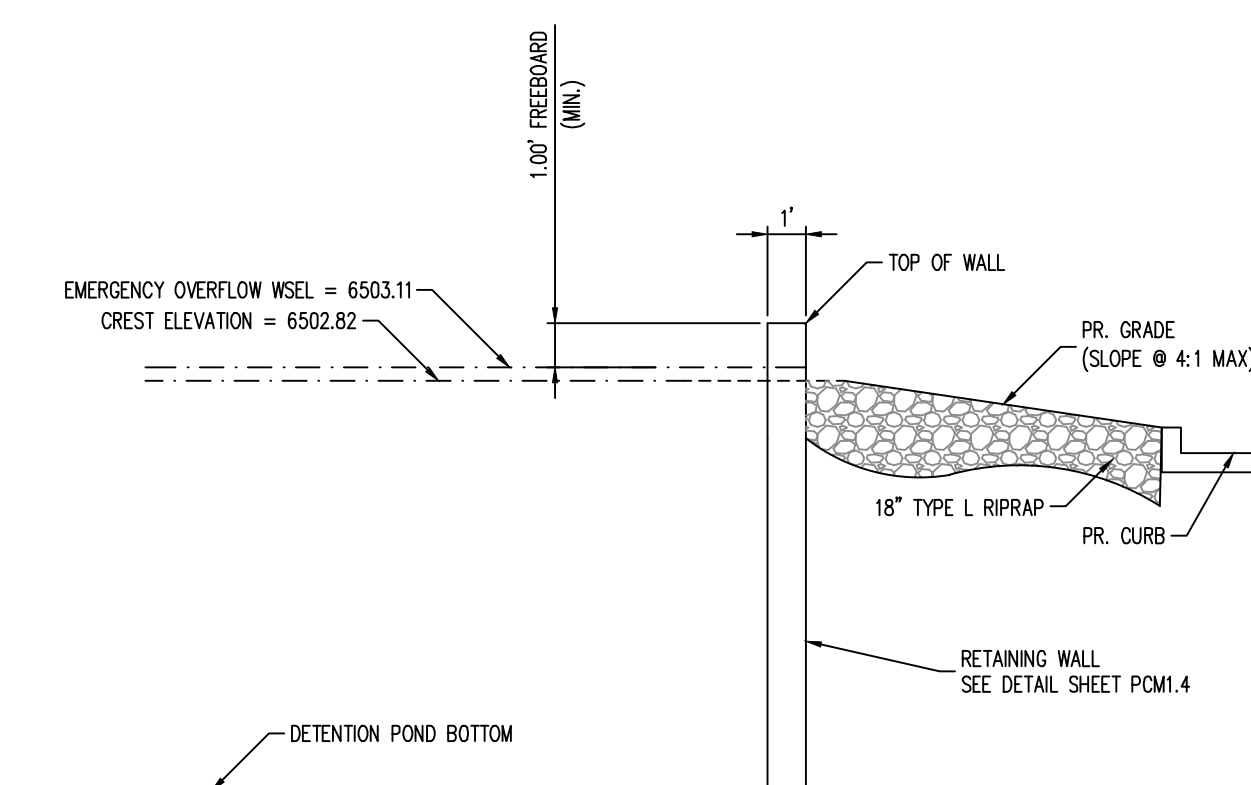

3 POND 100-YEAR OVERFLOW - PROFILE
NOT TO SCALE



COPYRIGHT
THESE PLANS ARE AN INSTRUMENT OF SERVICE
AND ARE THE PROPERTY OF GALLOWAY, AND MAY
NOT BE DUPLICATED, DISCLOSED, OR REPRODUCED
WITHOUT THE WRITTEN CONSENT OF GALLOWAY.
COPYRIGHTS AND INFINGEMENTS WILL BE
ENFORCED AND PROSECUTED.



PRIVATE PERMANENT CONTROL MEASURE PLAN
CONSTITUTION STORAGE

JOHNSON DEVELOPMENT ASSOCIATES

2460 CANADA DRIVE
COLORADO SPRINGS, CO 80915

#	Date	Issue / Description	Init.

Project No: JDA02
Drawn By: ASA/MRK
Checked By: BAS
Date: JULY 2023

MICROPOOL & OUTLET
STRUCTURE DETAILS



7/21/23

COPYRIGHT
THESE PLANS ARE AN INSTRUMENT OF SERVICE AND ARE THE PROPERTY OF GALLOWAY, AND MAY NOT BE DUPLICATED, DISCLOSED, OR REPRODUCED WITHOUT THE WRITTEN CONSENT OF GALLOWAY. COPYRIGHTS AND INFRINGEMENTS WILL BE ENFORCED AND PROSECUTED.



PRIVATE PERMANENT CONTROL MEASURE PLAN
CONSTITUTION STORAGE

JOHNSON DEVELOPMENT ASSOCIATES

2460 CANADA DRIVE
COLORADO SPRINGS, CO 80915

Table with 4 columns: #, Date, Issue / Description, Init.

Project No: JDA02
Drawn By: ASA/MRK
Checked By: BAS
Date: JULY 2023

RETAINING WALL DETAILS

PCM1.4

Sheet 6 of 6

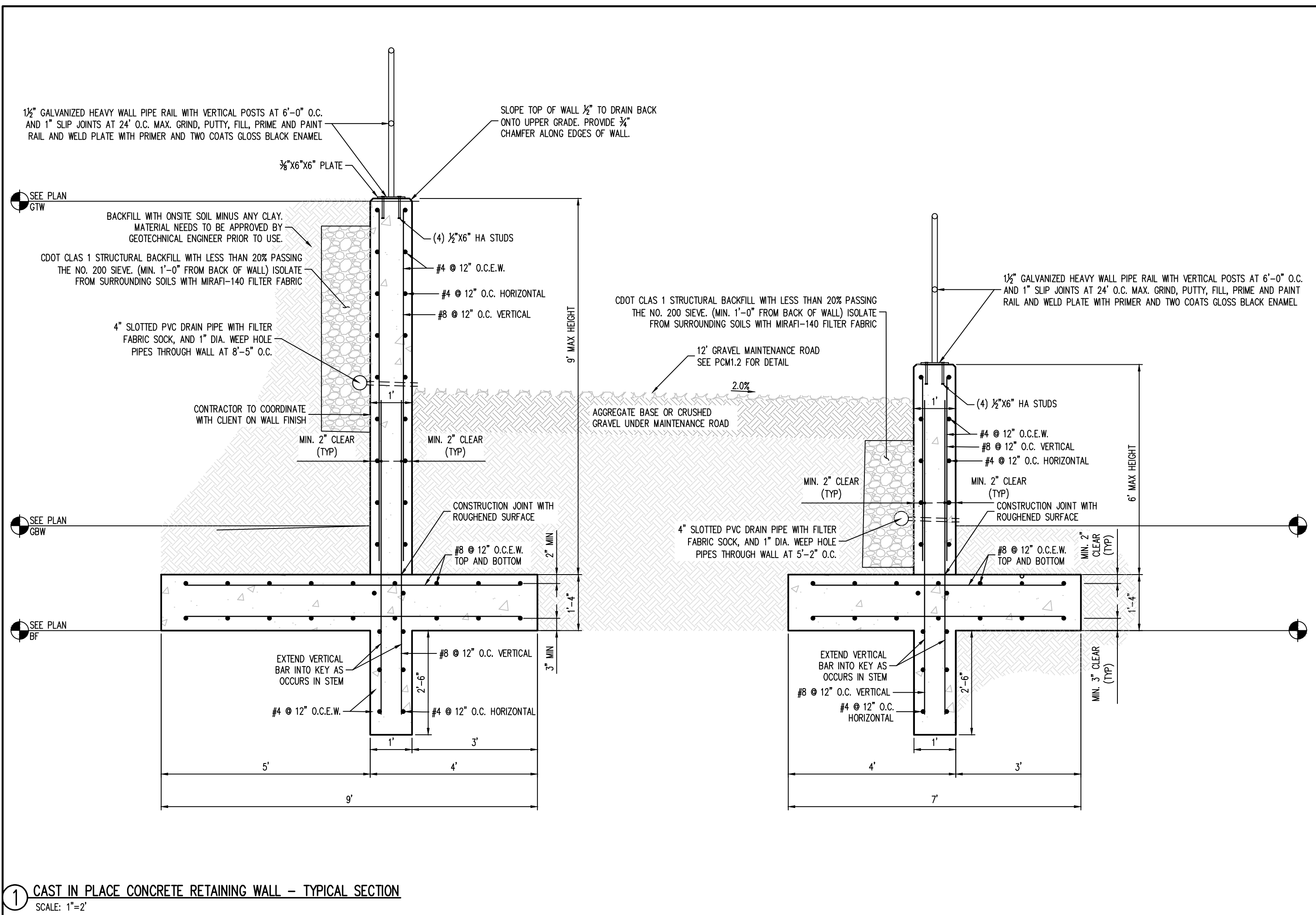

1 CAST IN PLACE CONCRETE RETAINING WALL - TYPICAL SECTION
SCALE: 1"=2'

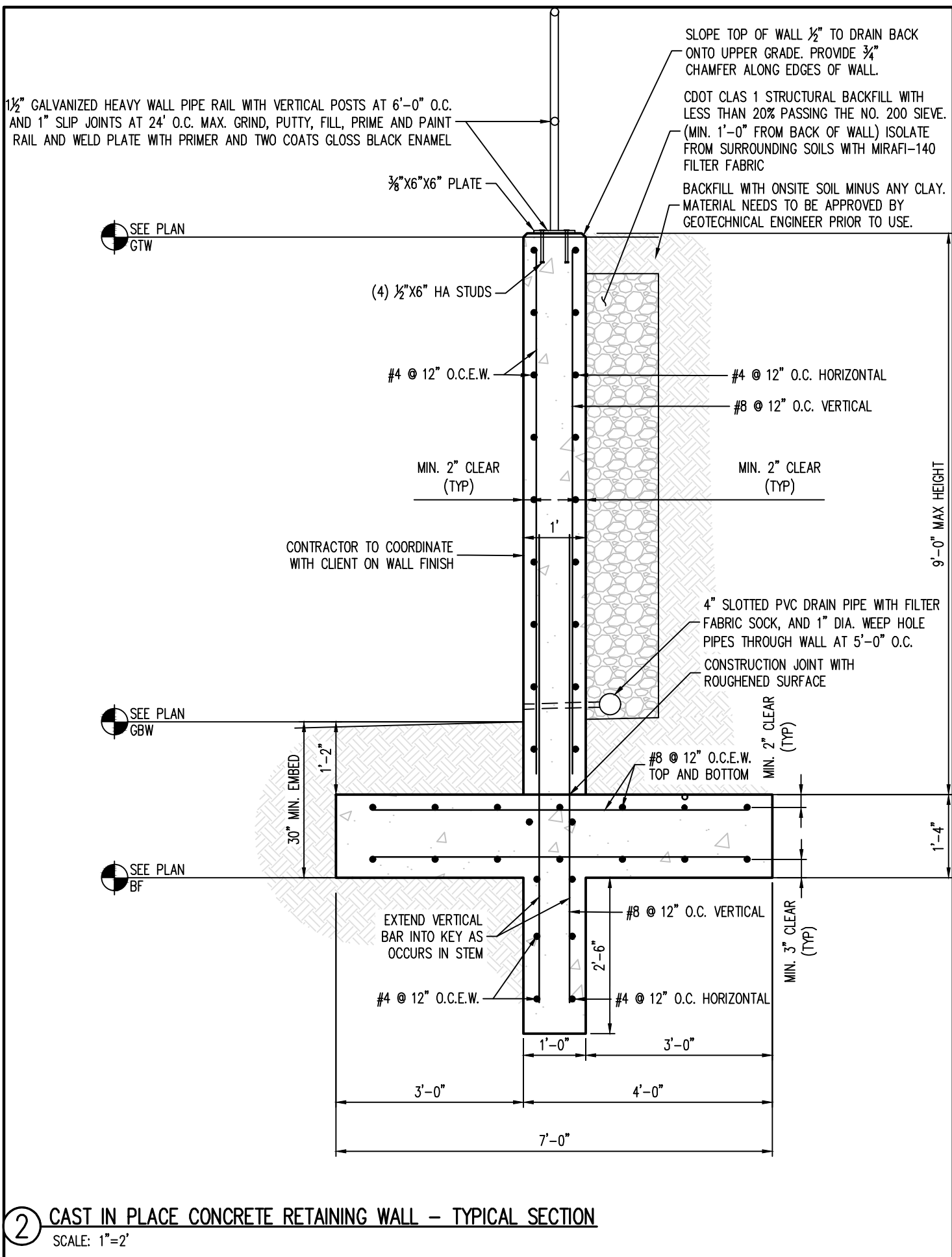

2 CAST IN PLACE CONCRETE RETAINING WALL - TYPICAL SECTION
SCALE: 1"=2'

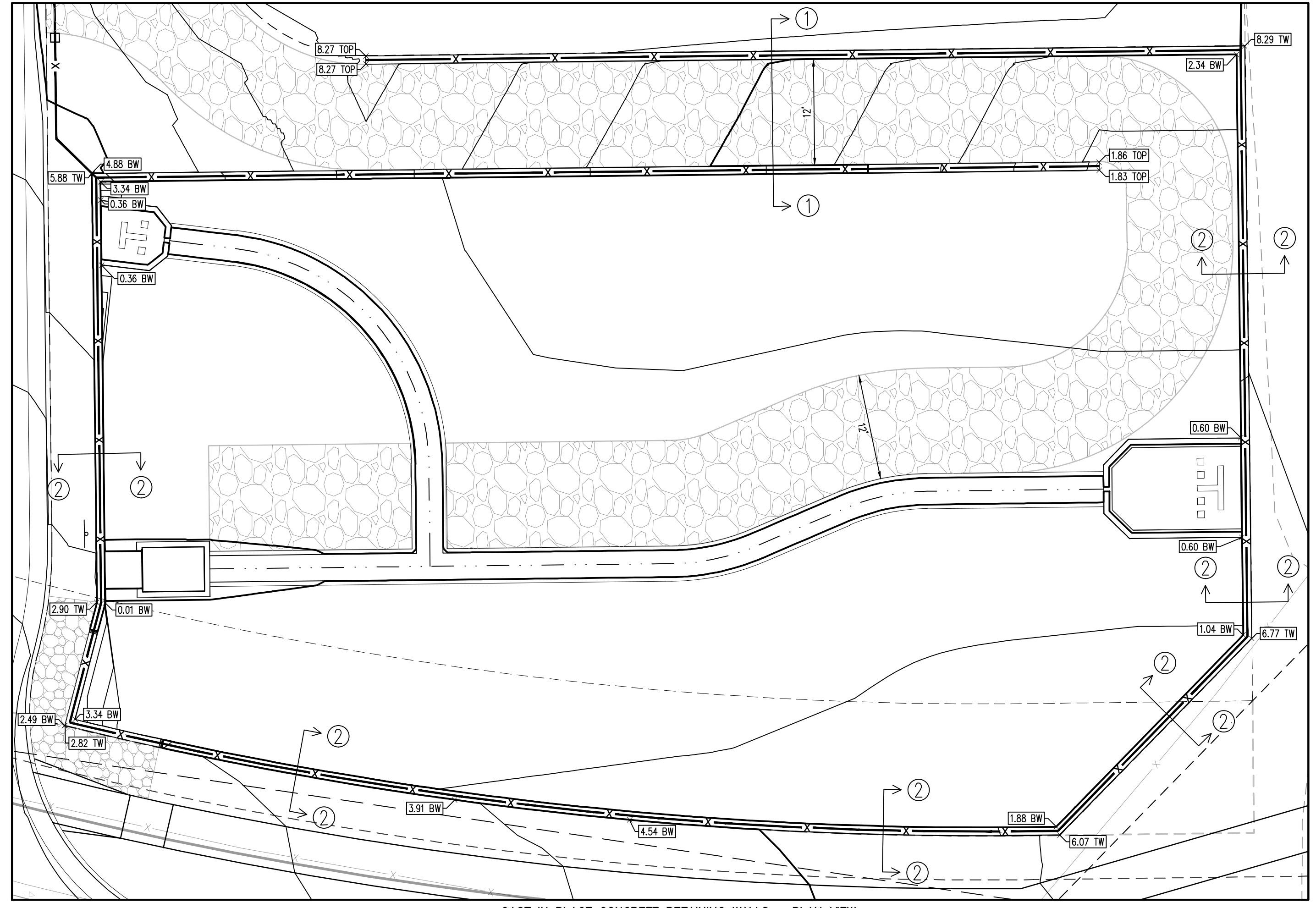

CAST IN PLACE CONCRETE RETAINING WALLS - PLAN VIEW

GENERAL STRUCTURAL NOTES

GENERAL REQUIREMENTS
GOVERNING CODE: THE DESIGN AND CONSTRUCTION OF THIS PROJECT IS GOVERNED BY THE 'NORTH CAROLINA BUILDING CODE', 2015 EDITION, HEREINAFTER REFERRED TO AS THE NCBC, AS ADOPTED BY CITY OF COLORADO SPRINGS CONSTRUCTION STANDARDS DIVISION UNDERSTOOD TO BE THE AUTHORITY HAVING JURISDICTION (AHJ).
TEMPORARY SHORING, BRACING: THE CONTRACTOR IS RESPONSIBLE FOR THE STRENGTH AND STABILITY OF THE STRUCTURE DURING CONSTRUCTION AND SHALL PROVIDE TEMPORARY SHORING, BRACING AND OTHER ELEMENTS REQUIRED TO MAINTAIN STABILITY UNTIL THE STRUCTURE IS COMPLETE. IT IS THE CONTRACTOR'S RESPONSIBILITY TO BE FAMILIAR WITH THE WORK REQUIRED IN THE CONSTRUCTION DOCUMENTS AND THE REQUIREMENTS FOR EXECUTING IT PROPERLY.
SITE VERIFICATION: THE CONTRACTOR SHALL VERIFY ALL DIMENSIONS AND CONDITIONS AT THE SITE. CONFLICTS BETWEEN THE DRAWINGS AND ACTUAL SITE CONDITIONS SHALL BE BROUGHT TO THE ATTENTION OF THE ARCHITECT/ENGINEER BEFORE PROCEEDING WITH THE WORK.
ADJACENT UTILITIES: THE CONTRACTOR SHALL DETERMINE THE LOCATION OF ALL ADJACENT UNDERGROUND UTILITIES PRIOR TO EARTHWORK, FOUNDATIONS, SHORING, AND EXCAVATION. ANY UTILITY INFORMATION SHOWN ON THE DRAWINGS AND DETAILS IS APPROXIMATE AND NOT NECESSARILY COMPLETE.

SPECIAL INSPECTIONS AND TESTING
INSPECTIONS: SPECIAL INSPECTIONS AND TESTING SHALL BE IN ACCORDANCE WITH THE STATEMENT OF SPECIAL INSPECTIONS PER RBC SECTION 109.7 AND IBC SECTIONS 1704, 1705, AS APPLICABLE.
SPECIAL INSPECTORS: SPECIAL INSPECTORS SHALL BE EMPLOYED BY THE OWNER. SPECIAL INSPECTORS SHALL BE QUALIFIED PERSONS WHO ARE REGISTERED WITH AN APPROVED AGENCY.
INSPECTION SUBMITTALS: SPECIAL INSPECTION REPORTS SHALL BE PROVIDED ON A WEEKLY BASIS. FINAL SPECIAL INSPECTION REPORTS WILL BE REQUIRED BY EACH SPECIAL INSPECTION FIRM PER IBC 1704.1.2. SUBMIT COPIES OF ALL INSPECTION AND TESTING REPORTS TO THE ARCHITECT/ENGINEER AND THE AUTHORITY HAVING JURISDICTION FOR REVIEW AS SOON AS THEY ARE AVAILABLE.

SCHEDULE OF SPECIAL INSPECTIONS table with columns: SOILS, CONCRETE CONSTRUCTION, DESCRIPTION OF SPECIAL INSPECTION, PERIODIC, CONTINUOUS.

SOILS AND FOUNDATIONS

FOUNDATIONS FOR ALL STRUCTURES SHALL BE DESIGNED AND CONSTRUCTED IN ACCORDANCE WITH THE GEOTECHNICAL REPORT PREPARED FOR THIS SITE.
THE CONTRACTOR MUST FULLY REVIEW THIS REPORT PRIOR TO CONSTRUCTION.
INFORMATION IN THE GEOTECHNICAL REPORT SUPERSEDES ANY CONFLICTING INFORMATION CONTAINED IN THE CDS.
GEOTECHNICAL REPORT PREPARED BY: KUMAR & ASSOCIATES, INC. REPORT NO.: REPORT - 21-2-272 ADDENDUM - 21-1-272 ADDENDUM - 21-2-272.A REPORT DATE: FEBRUARY 3, 2022 MARCH 22, 2022 FEBRUARY 16, 2023
DESIGN CRITERIA: NET ALLOWABLE SOIL BEARING PRESSURE D+L: 1500 PSF MINIMUM EMBEDMENT (BELOW EXT. GRADE OR SLAB SURGRADE): 30 INCHES EQUIVALENT FLUID PRESSURE, ACTIVE: 45 PSF EQUIVALENT FLUID PRESSURE, PASSIVE: 180 PSF
NOTE: PER GEOTECHNICAL ADDENDUM 21-2-272.A IT IS REQUIRED THAT CARE BE TAKEN NOT TO OVERCOMPACT THE BACKFILL. REFERENCE GEOTECHNICAL REPORT AND ADDENDUMS AND REPORT FOR ADDITIONAL INFORMATION.
SUBGRADE PREPARATION AND COMPACTION FOR ALL ITEMS ARE TO BE PREPARED IN SAME MANNER AS 2022 REPORT 21-2-272. OVEREXCAVATION AND REPLACEMENT OF ALL EXISTING FILL WILL BE REQUIRED WHERE PRESENT BELOW THE BEARING ELEVATION. ADDITIONALLY, OVEREXCAVATION AND REPLACEMENT OF THE CLAY SOILS WILL BE REQUIRED WHERE ENCOUNTERED WITHIN 3 FEET OF BEARING ELEVATION. REFERENCE GEOTECHNICAL REPORT AND ADDENDUMS AND REPORT FOR ADDITIONAL INFORMATION.

CAST-IN-PLACE CONCRETE

REFERENCE STANDARDS:
1. ACI 301-10 "SPECIFICATIONS FOR STRUCTURAL CONCRETE"
2. ACI 306-1-10 "SPECIFICATIONS FOR HOT WEATHER CONCRETING"
3. ACI 306-1-10 "SPECIFICATION FOR COLD WEATHER CONCRETING"
4. ACI 318-14 "BUILDING CODE REQUIREMENTS FOR STRUCTURAL CONCRETE"
5. ACI 117-10 "SPECIFICATION FOR TOLERANCES FOR CONCRETE CONSTRUCTION AND MATERIALS"
SUBMITTALS
PROVIDE ALL SUBMITTALS REQUIRED BY ACI 301 SECTION 4.1.2. SUBMIT MIX DESIGNS FOR EACH MIX IN THE TABLE BELOW. SUBSTANTIATING STRENGTH RESULTS FROM PAST TESTS SHALL NOT BE OLDER THAN 12 MONTHS PER ACI 318 SECTION 5.3.
CONCRETE MIX DESIGN REQUIREMENTS table with columns: STRENGTH Fc (PSI), TEST AGE, AGGREGATE, MAX. (IN), EXPOSURE CLASS, W/C RATIO, AIR CONTENT (% ± 1.5%), SLUMP, MAX. (IN).

CONCRETE REINFORCEMENT

MATERIALS: REINFORCING BARS ASTM: A615 GRADE 60 DEFORMED BARS
PLACING: CONFORM TO ACI 301 SECTION 3.3.2 "PLACEMENT." PLACING TOLERANCES SHALL CONFORM TO ACI 117.
CONCRETE COVER: CONCRETE CAST AGAINST EARTH: 3" CONFORM TO THE FOLLOWING COVER REQUIREMENTS: TIES IN COLUMNS AND BEAMS: 1-1/2" BARS IN SLABS: 3/4" BARS IN WALLS: 3/4" EXTERIOR BARS IN TILT-UP PANELS: 1"
SPICES: CONFORM TO ACI 301 SECTION 3.3.2.7. "SPICES"; REFER TO "TYPICAL LAP SPICE AND DEVELOPMENT LENGTH SCHEDULE" FOR TYPICAL REINFORCEMENT SPICES.

SITE LEGEND

- PROPERTY BOUNDARY LINE
- ADJACENT PROPERTY BOUNDARY LINE
- RIGHT OF WAY BOUNDARY LINE
- ROAD CENTERLINE
- EXISTING EASEMENT LINE
- PROPOSED EASEMENT LINE
- PROPOSED SWALE FLOWLINE
- PROPOSED RETAINING WALL

PAVING LEGEND

- STANDARD DUTY CONCRETE
- HEAVY DUTY CONCRETE
- STANDARD DUTY ASPHALT

CONTRACTOR RESPONSIBLE FOR AS-BUILT DRAWINGS, TESTS, REPORTS AND/OR ANY OTHER CERTIFICATES OR INFORMATION AS REQUIRED FOR ACCEPTANCE OF WORK FROM CITY, UTILITY DISTRICTS OR ANY OTHER GOVERNING AGENCY.

SURVEYOR TO OBTAIN AUTOCAD FILE FROM ENGINEER AND VERIFY ALL HORIZONTAL CONTROL DIMENSIONING PRIOR TO CONSTRUCTION STAKING. SURVEYOR MUST VERIFY ALL BENCHMARK, BASIS OF BEARING AND DATUM INFORMATION TO ENSURE IMPROVEMENTS WILL BE AT THE SAME HORIZONTAL AND VERTICAL LOCATIONS SHOWN ON THE DESIGN CONSTRUCTION DRAWINGS. PRIOR TO CONSTRUCTION STAKING ANY DISCREPANCY MUST BE REPORTED TO OWNER AND ENGINEER PRIOR TO CONTINUATION OF ANY FURTHER STAKING OR CONSTRUCTION WORK.

BASIS OF BEARINGS

BASIS OF BEARING: ALL BEARINGS ARE GRID BEARINGS OF THE COLORADO STATE PLANE COORDINATE SYSTEM, CENTRAL ZONE, NORTH AMERICAN DATUM 1983. THE NORTH LINE OF THE NORTHWEST QUARTER OF SECTION 5, TOWNSHIP 14 SOUTH, RANGE 65 WEST BEARS N89°20'41"E, MONUMENTED BY THE NORTHWEST CORNER OF SAID SECTION 5, BEING A 3-1/4" ALUMINUM CAP STAMPED "PLS 4842 1985" IN RANGE BOX, AND BY THE NORTH QUARTER CORNER OF SAID SECTION 5, BEING A 3-1/4" ALUMINUM CAP STAMPED "PLS 30829 2003", AS SHOWN HEREON.

BENCHMARK

COLORADO SPRINGS UTILITIES FACILITIES INFORMATION MANAGEMENT SYSTEM (FIMS) BENCHMARK SR07 BEING A 2" ALUMINUM CAP STAMPED "CSU FIMS CONTROL SR07" AT THE SOUTHEAST CORNER OF THE CONCRETE BASE FOR AN ELECTRIC VAULT ON THE WEST SIDE OF PETERSON ROAD, ABOUT 360' SOUTH OF THE CENTER LINE OF LEOTI DRIVE.

FIMS DATUM ELEVATION = 6534.61

CAUTION - NOTICE TO CONTRACTOR

1. ALL UTILITY LOCATIONS SHOWN ARE BASED ON MAPS PROVIDED BY THE APPROPRIATE UTILITY COMPANY AND FIELD SURFACE EVIDENCE AT THE TIME OF SURVEY AND IS TO BE CONSIDERED AN APPROXIMATE LOCATION ONLY. IT IS THE CONTRACTOR'S RESPONSIBILITY TO FIELD VERIFY THE LOCATION OF ALL UTILITIES, PUBLIC OR PRIVATE, WHETHER SHOWN ON THE PLANS OR NOT, PRIOR TO CONSTRUCTION. REPORT ANY DISCREPANCIES TO THE ENGINEER PRIOR TO CONSTRUCTION.
2. WHERE A PROPOSED UTILITY CROSSES AN EXISTING UTILITY, IT IS THE CONTRACTOR'S RESPONSIBILITY TO FIELD VERIFY THE HORIZONTAL AND VERTICAL LOCATION OF SUCH EXISTING UTILITY, EITHER THROUGH POT-Holing OR ALTERNATIVE METHOD. REPORT INFORMATION TO THE ENGINEER PRIOR TO CONSTRUCTION.

