



STORMWATER MANAGEMENT PLAN (SWMP)

EROSION CONTROL REPORT

Constitution Ave. and Marksheffel Rd.
El Paso County, Colorado

Project Number EDI000040

Prepared for:
Evergreen Development Company
2390 E. Camelback Road, Suite 410
Phoenix, Arizona 85016

December 22, 2017

Add "PCD File No. PPR-17-053"



TABLE OF CONTENTS

Vicinity Map

| | | |
|-------------------|---|-----------|
| 1.0 | General Requirements | 1 |
| 1.1 | Objectives | 1 |
| 1.2 | SWMP Availability | 1 |
| 1.3 | Definitions | 1 |
| 1.4 | Additional Permitting..... | 1 |
| 2.0 | Narrative Site Description | 2 |
| 2.1 | Existing Site Description | 2 |
| 2.2 | Wind and Rainfall Erodibility Sediment Migration Patterns..... | 2 |
| 2.3 | Nature of Construction Activity..... | 2 |
| 2.4 | Sequence of Major Activities..... | 2 |
| 2.5 | Site Disturbance | 2 |
| 2.6 | Existing Data | 2 |
| 2.7 | Existing Vegetation..... | 2 |
| 2.8 | Potential Pollution Sources | 3 |
| 2.9 | Non-Stormwater Discharges | 3 |
| 2.10 | Receiving Waters | 4 |
| 3.0 | Stormwater Management Controls | 5 |
| 3.1 | SWMP Administrator | 5 |
| 3.2 | Best Management Practices (BMPs) for Stormwater Pollution Prevention..... | 5 |
| 3.3 | Structural Practices for Erosion and Sediment Control..... | 5 |
| 3.4 | Non-Structural Practices for Erosion and Sediment Control..... | 7 |
| 3.5 | Phased BMP Installation..... | 9 |
| 3.6 | Material Handling and Spill Prevention..... | 9 |
| 3.7 | Vehicle Tracking Control..... | 10 |
| 3.8 | Waste Management and Disposal | 10 |
| 3.9 | Groundwater and Stormwater Dewatering | 10 |
| 4.0 | Final Stabilization and Long-Term Stormwater Management..... | 11 |
| 4.1 | Final Stabilization | 11 |
| 4.2 | Long-Term Stormwater Management..... | 11 |
| 5.0 | Inspection, Maintenance and Record Keeping..... | 12 |
| 5.1 | BMP Inspection | 12 |
| 5.2 | BMP Maintenance | 12 |
| 5.3 | Record Keeping..... | 12 |
| 6.0 | Additional SWMP and BMP Resources | 14 |
| References | 14 | |

APPENDICES:

APPENDIX A – Site Maps

APPENDIX B – Erosion Control Details

APPENDIX C – Copies of Permits / Applications

APPENDIX D – Inspection Logs

APPENDIX E – Contractor Inserts

1.0 General Requirements

1.1 Objectives

The objective of a Stormwater Management Plan (SWMP) is to identify the potential sources of pollution that result from construction activity, and describe the practices that will be used to reduce the pollutants in stormwater discharges from the site. The SWMP must be completed and implemented at the time the project breaks ground. The SWMP is a living document and must be revised as necessary during construction to accurately reflect the conditions and practices at the site.

This report summarizes the Stormwater Management Plan for the construction activity that will occur with the construction site at Constitution Ave. and Marksheffl Road. This plan has been prepared according to regulations of the Colorado Department of Public Health and Environment (CDPHE), El Paso County Engineering and Colorado Water Quality Control Division. The more stringent regulations will take precedence during all stormwater control activities.

1.2 SWMP Availability

The report shall remain at the construction site to allow for maintenance and inspection updates and for review during inspection.

1.3 Definitions

Best Management Practices (BMPs) – BMPs encompass a wide range of erosion and sediment control practices, both structural and non-structural in nature. BMPs are intended to remove or reduce potential water quality impacts from stormwater runoff.

Erosion Control BMPs – The practices are intended to prevent the erosion of soil. Examples include: temporary stabilization, preserving existing vegetation and minimizing the amount of disturbed area through phasing.

Sediment Control BMPs – These practices are designed to remove and reduce sediment from runoff. Examples include: straw wattles, silt fence and inlet protection.

Non-structural BMPs – These BMPs prevent or limit the entry of pollutants into stormwater at their source through operational or managerial techniques. Examples include: preservation of natural vegetation, preventive maintenance and spill response procedures.

Structural BMPs – Structural practices are designed to control on-site erosion and prevent sediment from migrating within the project site as well as off-site during construction. Examples include: diversion structures, inlet protection and silt fence.

1.4 Additional Permitting

Because the proposed site is less than an acre, a Colorado Department of Public Health and Environment (CDPHE) Stormwater Permit will not be required. Environmental permitting not described within this report would likely be required through separate documentation. Examples include the Construction Dewatering Permit for groundwater, and the Air Pollution Emission Notice (APEN). The CDPHE website contains links for these permits, along with many other potential permits. It is the contractor's responsibility to ensuring that the proper permits are acquired.

2.0 Narrative Site Description

2.1 Existing Site Description

The site is located in El Paso County, Colorado. The site is at the Southeast corner of Constitution Avenue and Marksheffel Road. The site lies within the North 1/2 of the Northwest ¼ of Section 4, Township 14 South, Range 65 West, of the 6th Principal Meridian.

Wind and Rainfall Erodibility | Sediment Migration Patterns

According to the Natural Resources Conservation Service website (www.websoilsurvey.nrcs.usda.gov), the applicable soil erodibility factor (K) is 0.20. This value is indicative of soils less susceptible to rainfall erosion.

The long-term likelihood of erosion and sediment problems occurring on-site after final on-site improvements is minimal due to the landscaping and placement of impervious areas that will permanently stabilize the project site disturbed by proposed construction activity. During construction, the BMPs used onsite as described herein have been selected to prevent erosion and limit sediment migration.

2.2 Nature of Construction Activity

The proposed Constitution Avenue and Marksheffel Road project will strip and grade the site, include installation of wet utilities such as water and sanitary sewer, and also include the installation storm sewer, asphalt parking, curb and gutter, pedestrian sidewalks, and a commercial building.

Sequence of Major Activities

To complete the project, basic construction activities will take place. The project will begin by stripping the site of topsoil and removing existing site improvements. Then the installation of underground utilities will come next followed by fine grading and the laying of pavement and curb and gutter along with building infrastructure. Upon completion of fine site grading, the expectation is that the site will be stabilized until such time as final site improvements are determined approved.

Site Disturbance

The total area of the project site is 0.82 acres. The total area of the project to undergo disturbance is 0.90 acres. Site disturbance is expected to be uniform.

At this time, the construction schedule of land disturbing activities is not available from the contractor.

2.3 Existing Data

In order to complete the associated construction plans, a topographical survey of the site was completed by Galloway on 10/02/2017.

2.4 Existing Vegetation

The existing ground cover consists of seeded grasses. The existing on-site runoff generally drains from northeast to the southwest across slight grades between 1% – 2% to Marksheffel Road which is then routed into an existing storm sewer.

The pre-disturbance individual plant density is over 70 percent. Final stabilization will include an individual plant density of at least 70 percent of pre-disturbance levels, or equivalent permanent, physical erosion reduction methods. Most of the *total* disturbed area will be permanently

stabilized with asphalt. The remaining area will be stabilized with landscaping such as sod and planting beds. **It is highly recommended that pre-construction photos be taken to clearly document vegetative conditions prior any disturbance activities.**

2.5 Potential Pollution Sources

On most construction sites, there are a number of potential pollution sources which could affect water quality. It is not possible for this report to identify all materials that will be used or stored on the construction site. It is the sole responsibility of the contractor to identify and properly handle all materials that are potential pollution sources. The following are some common examples of potential pollution sources:

- All disturbed and stored soils
- Vehicle tracking of sediments
- Management of contaminated soils
- Loading and unloading operations
- Outdoor storage activities (e.g., building materials, fertilizers, chemicals, etc.)
- Vehicle and equipment maintenance and fueling
- Significant dust or particulate generating processes
- Routine maintenance activities involving fertilizers, pesticides, detergents, fuels, solvents, oils, etc.
- On-site waste disposal practices (e.g., waste piles, liquid wastes, dumpsters, etc.)
- Concrete truck/equipment washing, including the concrete truck chute and associated fixtures and equipment
- Dedicated asphalt and concrete batch plants
- Non-industrial waste sources such as worker trash and portable toilets
- Other areas or procedures where potential spills can occur

Management of Contaminated Soils: We are not aware of on-site contaminated soils. However, the contractor should conduct a thorough, pre-construction environmental site assessment. If contaminated soils are discovered, the contractor will identify appropriate practices and procedures for the specific contaminants discovered on-site.

Loading and Unloading Operations: During site demolition, material loading and unloading will occur on-site. As site development and building construction progresses, space constraints will limit the number of on-site locations for loading and unloading activities. The contractor will be responsible for the proper handling and management of pollution sources during loading and unloading operations.

Dedicated Asphalt and Concrete Batch Plants: Neither a dedicated asphalt or concrete batch plant will be constructed on-site.

2.6 Non-Stormwater Discharges

The Stormwater Construction Permit only covers discharges composed entirely of stormwater. Emergency firefighting water is the only authorized exception.

Concrete Washout water can NOT be discharged to surface waters or to storm sewer systems without separate permit coverage. The discharge of Concrete Washout water to the ground, under specific conditions, may be allowed by the Stormwater Construction Permit when appropriate BMPs are implemented.

Construction Dewatering water can NOT be discharged to surface waters or to storm sewer systems without separate permit coverage. The discharge of Construction Dewatering water to the ground, under specific conditions, may be allowed by the Stormwater Construction Permit when appropriate BMPs are implemented.

The discharge of pumped stormwater, ONLY, from excavations, ponds, depressions, etc., to surface waters, or to a municipal separate storm-sewer system (MS4) is allowed by the Stormwater Construction Permit, as long as the dewatering activity and associated BMPs are identified in the SWMP (including location of the activity), and BMPs are implemented in accordance with the SWMP.

2.7 Receiving Waters

The East Fork Sub Tributary of Sand Creek is the ultimate receiving water.

Stormwater Management Controls

2.8 SWMP Administrator

A SWMP Administrator must be designated in conjunction with the Stormwater Permit. This person shall be responsible for developing, implementing, maintaining and revising the SWMP. The SWMP Administrator will also be the contact for all SWMP-related issues and will be the person responsible for the accuracy, completeness and implementation of the SWMP. The Administrator should be a person with authority to adequately manage and direct day-to-day stormwater quality management activities at the site.

The SWMP Administrator for this site is:

Name:

Company:

Phone:

E-mail:

2.9 Best Management Practices (BMPs) for Stormwater Pollution Prevention

Best Management Practices (BMPs) are defined as a method, activity, maintenance procedure or other management practice for reducing the amount of pollution entering a water body. The term originated from rules and regulations in Section 208 of the Clean Water Act.

Beginning with mobilization, and throughout the entire construction of the buildings, erosion control devices shall be installed and maintained to minimize pollutant migration. The BMPs may be installed or implemented in phases, or not at all, depending on actual conditions encountered at the site. It is the responsibility of the contractor to make the determination as to what practices should be employed and when. In the event that a review agency deems BMPs to be insufficient, it shall be the responsibility of the contractor to implement modifications as directed.

The Erosion Control Exhibit (Refer to sheet EC01 in Appendix A) illustrates the initial placement and assumed location for each of the BMPs. Details for recommended BMPs are included in Appendix B. The details should be used for additional information on installation and maintenance of BMPs described herein. Details for Structural and Non-Structural BMPs have been included in Appendix B. These details should be used for additional information on installation and maintenance of BMPs specified in this report. It is also intended to serve as a resource for additional BMPs that may be appropriate for the site that have not specifically been mentioned in the report.

2.10 Structural Practices for Erosion and Sediment Control

Structural BMPs are physical devices that prevent or minimize water quality impacts associated with construction site stormwater runoff. These devices can be temporary or permanent, and the installation of individual components will vary depending on the stage of construction.

Refer to the Erosion Control Plan in the Appendix A for the assumed location of all BMPs. Construction Details for Temporary BMPs are located in Appendix A for reference.

The final determination of which BMPs will be installed, where they will be located and when they will be installed shall be made by the contractor, along with all documentation throughout the construction process.

Silt Fencing (Phases I – IV)

Silt fencing shall be provided to prevent migration of sediment off-site into the public right-of-way or onto adjacent properties. All silt fencing shall be installed prior to any land disturbing activity (i.e., stockpiling, stripping, grading, excavation, earthwork activities, etc.).

The silt fence inspections should identify tears or holes in the material as well as check for slumping fence or undercut areas that allow flows to bypass the fencing. The damaged sections of fencing should be repaired or replaced. Sediment accumulations equal to or greater than 6 inches behind the silt fence should be removed to maintain BMP effectiveness.

At a minimum, it is suggested that silt fencing shall be located along the entire perimeter of the site with the exceptions of construction entrances

Vehicle Tracking Control Pad (Phases I – II)

A Vehicle Tracking Control (VTC) pad shall be provided to minimize tracking of mud and sediment onto paved surfaces and neighboring roadways. The vehicle tracking control pad shall be installed prior to any land disturbing activity (e.g., stockpiling, stripping, grading, etc.). The vehicle tracking control pad should be located at any and all existing and future vehicle accesses being used during any of the construction phases. These locations will primarily be dictated by gates or openings in the temporary construction fencing.

Vehicle tracking pads should be inspected for degradation. The aggregate material should remain rough and be replaced if the area becomes clogged with water and/or excess sediment.

The current plan shows one vehicle tracking control pad at the northeast corner of the property where the proposed entrance will be located.

Curb Inlet Protection (Phases I – IV)

Curb inlet protection shall be provided to prevent sediment transport from adjacent earthwork disturbance. If pavement is constructed adjacent to the inlets or if the area adjacent to the inlet is changed such that the wattle type filter is no longer effective, it shall be the responsibility of the contractor to ensure that an appropriate method is used instead. For example, the wattle filter could be reused, or a gravel-block inlet filter may be installed.

Concrete Washout Area (Phases II – III)

A concrete washout area should be provided on the site. The washout can be a lined or unlined excavated pit in the ground, a commercially manufactured prefabricated container or an aboveground holding area. The concrete washout area must be located a minimum of 400 feet from any natural drainage way or body of water and at least 1000 feet from any wells or drinking water sources. If not lined, the concrete washout area should not be located in an area where shallow groundwater may be present. The contractor shall clearly show the desired location and access to the Concrete Washout Area on the Stormwater Management Plan - Dynamic Site Plan. The contractor shall place a Vehicle Tracking Pad if the selected location for the Concrete Washout Area is detached from pavement. Clear signage identifying the concrete washout should also be provided.

The Concrete Washout Area should be inspected regularly with particular attention being paid to signage to ensure that the area is clearly marked. Confirmation that the washout

is being used should also be noted to ensure that other undesignated areas of the site are not being used incorrectly as a concrete washout.

Permanent/Established Vegetation (Phase IV)

Permanent or established vegetation and landscaping is considered a permanent form of sediment and erosion control. Areas where the previous conditions apply will contain sufficient permanent BMPs such as sod or landscape material (e.g., smooth river rock/cobble and wood mulch).

2.11 Non-Structural Practices for Erosion and Sediment Control

Non-Structural BMPs are practices or activities that are implemented to prevent erosion from happening or to limit erosion once it occurs. These BMPs can be a practice resulting in a physical change to the site, such as mulching or slope stabilization. They can also result in behavioral changes on the site, such as changes to construction phasing to minimize exposure to weather elements or increased employee awareness gained through training.

Protection of Existing Vegetation (Phases I - IV)

Protection of existing vegetation on a construction site can be accomplished through installation of a construction fence around the area requiring protection. In cases where upgradient areas are disturbed, it may also be necessary to install perimeter controls to minimize sediment loading to sensitive areas such as wetlands.

Trees that are to remain after construction is complete must also be protected. Most tree roots grow within the top 12"-18" of soil and soil compaction is a significant threat to tree health. As such, particular care should be taken to avoid activities within the drip-line of the tree. Direct equipment damage should also be prevented. The most effective way to ensure the health of trees is to establish a protection zone at the drip-line of the tree.

Fencing should be inspected and repaired as needed. If damage occurs to a tree, an arborist should be consulted. If a tree is damage beyond repair, the City Forester should be consulted on remediation measures.

Stockpile Management (Phases I - IV)

Stockpile management should be utilized to minimize erosion and sediment transport BMPs should be placed around the perimeter of the stockpile, and a designated from soil stockpiles. In general, soil stockpiles should be located a minimum of 100 feet from any drainage way and 50 feet from any storm sewer inlets. Where practical, choose a stockpile location that will remain undisturbed for the longest period of time as the phases of construction progress. Sediment control access point on the upstream side of the stockpile should be identified. BMPs such as surface roughening, temporary seeding, mulching, erosion control blankets or soil binders should be used to stabilize the stockpile surface.

As a part of stockpile management, regular inspections of the perimeter controls should be completed. If BMPs have been utilized to stabilize the surface of the stockpile, which is usually true for stockpiles that sit longer than 30 days, they should be inspected and repaired as needed.

Mulching (Phases I - IV)

Mulching helps reduce erosion by protecting bare soil from rainfall impact, increasing

infiltration and reducing runoff. Although often applied in conjunction with temporary or permanent seeding, it can also be used for temporary stabilization of areas that cannot be reseeded due to seasonal constraints. The most common type of mulch used is hay or grass that is crimped into the soil to keep it secure.

The Contractor shall mulch all planted areas within twenty-four (24) hours after planting. Only weed-free and seed-free straw mulch may be used. Straw mulch should be applied at two (2) tons per acre, and shall be adequately secured by crimping, tackifier, netting or blankets. Hydraulic mulching may also be used on steep slopes or where access is limited. In the case that hydraulic mulching is utilized, the contractor shall use wood cellulose fibers mixed with water at two thousand to two thousand five hundred (2,000-2,500) pounds per acre and organic tackifier at one hundred to four hundred (100-400) pounds per acre.

Wind Erosion/Dust Control (Phases I - IV)

Wind Erosion and Dust Control BMPs help to keep soil particles from entering the air as a result of land disturbing construction activities. Examples include the use of a water truck or irrigation/sprinkler system to wet the top layer of disturbed soil, seeding and mulching, soil binders or wind fences.

If a water truck or irrigation/sprinkler system is utilized, then monitoring for sufficient water application is crucial to ensuring soil particles don't become airborne. Equally important is monitoring for overwatering, as too much water can lead to increased erosion and sediment laden construction site runoff.

Good Housekeeping Practices (Phases I - IV)

Good housekeeping practices that will prevent pollution associated with solid, liquid and hazardous construction-related materials and wastes should be implemented throughout the project. Examples of good housekeeping include providing an appropriate location for waste management containers, establishing proper building material staging areas, designating paint and concrete washout areas and establishing proper equipment/vehicle fueling and maintenance practices. Development of a spill prevention and response plan is another example of Good Housekeeping practices that should be used on the project.

Street Sweeping and Vacuuming – Street sweeping and vacuuming should be used to remove sediment that has been tracked onto adjacent roadways. Roadways should be inspected at least once a day, and sediment should be removed as needed. A check of inlet protection should be completed after sweeping to ensure nothing was displaced during sweeping operations.

Waste Management – Designate trash and bulk waste collection areas on-site. When possible, materials should be recycled. Hazardous material waste should be segregated from other solid waste. Waste collection areas should be located away from streets, gutters, watercourses and storm drains. Dumpsters should be located near site entrances to minimize traffic on disturbed soils, and they should be placed on a level soil surface.

Establish Proper Building Material Handling and Staging areas – Clearly designate site areas for staging and storage of building materials. Provide appropriate BMPs to ensure that spills or leaks are contained.

Establish Proper Equipment/Vehicle Fueling and Maintenance Practices – If needed, create a clearly designated on-site fueling and maintenance area that is clean and dry. Provide appropriate BMPs to ensure that spills or leaks are contained.

Saw Cutting Pollution Prevention (Phase II)

The following protocol is recommended to prevent dust and slurry from asphalt and concrete saw cutting activities from migrating into the existing storm drain system.

- Slurry and cuttings shall be vacuumed during cutting and surfacing operations
- Slurry and cuttings shall not remain on permanent concrete or asphalt pavement overnight
- Slurry and cuttings shall not drain to any natural or constructed drainage conveyance
- Collected slurry and cuttings shall be disposed of in a manner that does not violate groundwater or surface water standards

2.12 Phased BMP Installation

It is important to recognize the four (4) major *Development Phases* as defined by the State of Colorado's Stormwater Discharge Permit (SDP). These four development phases have been distinguished to aid in the appropriate timing of installation/implementation of BMPs at different stages of the construction process. These phases are described as follows:

Phase I – Grading Stage; BMPs for initial installation of perimeter controls

Phase II – Infrastructure Stage; BMPs for utility, paving and curb installation

Phase III – Vertical Construction Stage; BMPs for individual building construction.

Phase IV – Permanent BMPs and final site stabilization.

2.13 Material Handling and Spill Prevention

Potential pollution sources, as discussed in earlier sections, are to be identified by the contractor. Spill prevention procedures are to be determined and put in place prior to construction by the contractor. A spill and flooding response procedure must also be determined and put in place prior to construction by the contractor. Additionally, steps should be taken to reduce the potential for leaks and spills coming into contact with stormwater runoff.

A notification procedure must be put in place by the contractor, by which workers would first notify the site construction superintendent, who would then notify the SWMP Administrator. Depending on the severity of the spill, the site construction superintendent and SWMP Administrator would possibly notify the Colorado Department of Public Health and Environment - Water Quality Control Division, downstream water users or other appropriate agencies. **The release of any chemical, oil, petroleum product, sewage, etc., which enter waters of the State of Colorado (which include surface water, ground water, and dry gullies or storm sewers leading to surface water) must be reported immediately to the Division's emergency spill reporting line at (877) 518-5608.** All spills that will require cleanup, even if the spill is minor and does not need to be reported to the state, should still be reported to the El Paso County Engineering office at 719-520-7276.

While not expected with this project, it will be the responsibility of the contractor to designate a fueling area and take the necessary precautions to ensure that no stormwater pollution occurs in the event that a fueling area is needed. Fueling areas shall be located a minimum 100 feet from all drainage courses. A 12-inch high compacted earthen berm capable of retaining potential spills shall enclose fueling areas. Other secondary containment devices can be used instead of the earthen berm. The area shall be covered with a non-porous lining to prevent soil contamination.

Printed instructions for cleanup procedures shall be posted in the fueling area and appropriate fuel absorbents shall be available along with containers for used absorbents.

2.14 Vehicle Tracking Control

In addition to the vehicle tracking pads discussed previously, additional measures can be taken to minimize and control sediment discharges from the site due to vehicle tracking. These measures can include fencing around the site to control access points. Regular street sweeping can also be used to minimize the transmission of sediment from the site due to vehicles leaving the site. The use of gravel parking areas and wash racks can also be implemented to ensure minimal vehicle tracking from the site. Minimizing or limiting the number of vehicles accessing the site by providing designated delivery areas, or by restricting deliveries when the site is muddy is also encouraged.

2.15 Waste Management and Disposal

It will be the responsibility of the contractor to designate a concrete truck chute washout area and to clearly identify that area. Detailed information about the design and maintenance of the Concrete Washout can be found under the Structural Practices section of this report. At no time should untreated wash water be allowed to discharge from the site or to enter a storm drain system or stream. Upon completion of construction activities the concrete washout material shall be removed and properly disposed of prior to the area being restored.

Any waste material that currently exists on the site or that is generated by construction will be disposed of in such a manner as to not cause pollutants in stormwater discharges. If waste is to be stored on-site, it shall be in an area located a minimum of 100 feet from all drainage courses. Whenever waste is not stored in a non-porous container, it shall be in an area enclosed by a 12-inch high compacted earthen berm or some other approved secondary containment device. The area shall be covered with a non-porous lining to prevent soil contamination. Whenever precipitation is predicted, the waste shall be covered with a non-porous cover and anchored on all sides to prevent its removal by wind. On-site waste disposal practices, such as dumpsters, should be covered or otherwise contained as to prevent dispersion of waste materials by wind. It shall also be the responsibility of the contractor to maintain a clean jobsite and to prevent the dispersion of waste material and potential pollutants into adjacent properties or waterways.

The location of, and protective measures for, temporary restroom facilities shall be the responsibility of the SWMP Administrator.

2.16 Groundwater and Stormwater Dewatering

The BMPs selected for construction dewatering vary depending on the site-specific features, such as soils, topography, discharge quantities and discharge location. Typically, dewatering involves pumping water from an inundated area to a BMP, prior to the water being released downstream into a receiving waterway, sediment basin, or well-vegetated area. Acceptable BMPs included discharging water into a sediment trap or basin, using a dewatering filter bag or using a series of sediment logs. A settlement tank or an active treatment system can also be utilized as long as it is not a chemically induced treatment system. Another commonly used method to handle the pumped water is the "sprinkler method," which involves applying the water to vegetated areas through a perforated discharge hose. Dispersal from a water truck for dust control can also be used to disperse the pumped water.

3.0 Final Stabilization and Long-Term Stormwater Management

3.1 Final Stabilization

All disturbed areas will be seeded, crimped and mulched. Soil amendments such as compost, peat, aged manure, or other similar materials, shall also be utilized. Soil amendments shall be tilled into the soil to a minimum depth of 6". As defined by the Colorado Department of Public Health and Environment (CDPHE) in the General Permit Application for Stormwater Discharges, "Final stabilization is reached when all soil disturbing activities at the site have been completed, and uniform vegetative cover has been established with a density of at least 70 percent of pre-disturbance levels or equivalent permanent, physical erosion reduction methods have been employed."

3.2 Long-Term Stormwater Management

The primary method of long-term stormwater management will be a developed site mostly comprised of rooftops roads and drives.

Inspection, Maintenance and Record Keeping

3.3 BMP Inspection

All temporary erosion control facilities shall be inspected at a minimum of once every two (2) weeks and after each significant storm event or snowmelt. Repairs or reconstruction of BMPs, as necessary, shall occur as soon as possible in order to ensure the continued performance of their intended function. It is the responsibility of the SWMP Administrator to conduct bi-weekly inspections, maintain BMPs if needed, keep records of site conditions and inspections and to update the SWMP as necessary.

The construction site perimeter, disturbed areas, all applicable/installed erosion and sediment control measures and areas used for material storage that are exposed to precipitation shall be inspected for evidence of, or the potential for, pollutants entering the drainage system. Erosion and sediment control measures identified in the SWMP shall be observed to ensure that they are operating correctly. Particular attention should be paid to areas that have a significant potential for stormwater pollution, such as demolition areas, concrete washout locations and vehicle entries to the site. The inspection must be documented to ensure compliance with the permit requirements.

3.4 BMP Maintenance

BMPs not operating in accordance with the SWMP must be addressed as soon as possible to prevent the discharge of pollutants. If modifications are necessary, such modifications shall be documented so that the SWMP accurately reflects on-site conditions. **The SWMP needs to accurately represent field conditions at all times.**

Uncontrolled releases of mud, muddy water or measurable amounts of sediment found off-site will be recorded with a brief explanation of the measures taken to clean-up the sediment that has left the site, as well as the measures taken to prevent future releases. This record shall be made available to the appropriate public agencies (Colorado Department of Public Health and Environment, Water Quality Control Division; Environmental Protection Agency; El Paso County Engineering; etc.) upon request.

Preventative maintenance of all temporary and permanent erosion control BMPs shall be provided in order to ensure the continued performance of their intended function. Temporary erosion control measures are to be removed after the site has been sufficiently stabilized as determined by the City of Loveland. Maintenance activities and actions to correct problems shall be noted and recorded during inspections.

Inspection and maintenance procedures specific to each BMP identified with this SWMP are discussed in Section 3. Details have also been included with Appendix B.

3.5 Record Keeping

Documentation of site inspections must be maintained. The following items are to be recorded and kept with the SWMP:

- Date of Inspection
- Name(s) and title(s) of personnel making the inspection
- Location(s) of sediment discharges or other pollutants from the site
- Location(s) of BMP's that need to be maintained
- Location(s) of BMP's that failed to operate as designed or proved inadequate
- Locations(s) where additional BMP's are needed that were not in place at the time of inspection

- Deviations from the minimum inspection schedule
- Descriptions of corrective action taken to remedy deficiencies that have been identified
- The report shall contain a signed statement indicating the site is in compliance with the permit to the best of the signer's knowledge and belief after corrective actions have been taken.

Provided within Appendix D of this SWMP is an Example Inspection Log to aid in the record keeping of BMP inspections and maintenance. Photographs, field notebooks, drawings and maps should be included when appropriate.

In addition to the Inspection Log, records should be kept documenting:

- BMP maintenance and operation
- Stormwater contamination
- Contacts with suppliers
- Notes on the need for and performance of preventive maintenance and other repairs
- Implementation of specific items in the SWMP
- Training events (given or attended)
- Events involving materials handling and storage
- Contacts with regulatory agencies and personnel
- Notes of employee activities, contact, notifications, etc.

Records of spills, leaks or overflows that result in the discharge of pollutants must be documented and maintained. A record of other spills that are responded to, even if they do not result in a discharge of pollutants, should be made. Information that should be recorded for all occurrences includes the time and date, weather conditions, reasons for the spill, etc. Some spills may need to be reported to authorities immediately. Specifically, a release of any chemical, oil, petroleum product, sewage, etc., which may enter waters of the State of Colorado (which include surface water, ground water and dry gullies or storm sewers leading to surface water) must be reported to the CDPHE.

Additionally, the "Dynamic Site Plan" is intended to be a "living document" where the SWMP Administrator can hand write the location of BMPs as they are installed to accurately reflect the current site conditions. Also on the "Dynamic Site Plan" should be a "Table of Construction Sequence and BMP Application/Removal" that the SWMP Administrator can use to document when BMPs were installed or removed in conjunction with construction activities. These items will be included as an aid to the SWMP Administrator, and other methods of record keeping are at his or her discretion.

The Stormwater Management Plan (both the text and map) is not a static document, it is a dynamic device intended to be kept current and logged as construction takes place. It shall be the responsibility of the SWMP Administrator and/or the permit holder (or applicant thereof) to ensure the plan is properly maintained and followed. Diligent administration is critical, including processing the Notice to Proceed and noting on the Stormwater Management Plan the dates that various construction activities occur and respective BMPs are installed and/or removed.

4.0 Additional SWMP and BMP Resources

Urban Drainage and Flood Control District

Urban Storm Drainage Criteria Manual - Volume 3 "Best Management Practices"

Colorado Department of Transportation

Erosion Control and Stormwater Quality Guide
BMP Field Academy

EPA Menu of BMP's

Construction Site Storm Water Runoff Control

International Stormwater Best Management (BMP) Database

Rocky Mountain Education Center

Rocky Mountain Education Center

Red Rocks Community College, Lakewood

Keep It Clean Partnership

Boulder

References

1. Soil Resource Report for Larimer County Area, Colorado, Natural Resources Conservation Service, United States Department of Agriculture.
2. Urban Storm Drainage Criteria Manual, Volumes 1-3, Urban Drainage and Flood Control District, Water Resources Publications, LLC., Denver, Colorado, Updated November 2010.
3. Natural Resources Conservation Service Web Soil Survey at websoilsurvey.nrcs.usda.gov/app.

Appendix A

(Site Maps)

CLAREMONT RANCH FILING NO. 9C

LOT 2B, BLOCK 1

A PORTION OF SECTION 4, TOWNSHIP 14 SOUTH, RANGE 65 WEST
OF THE 6TH P.M., EL PASO COUNTY, COLORADO

GRADING AND EROSION CONTROL PLAN

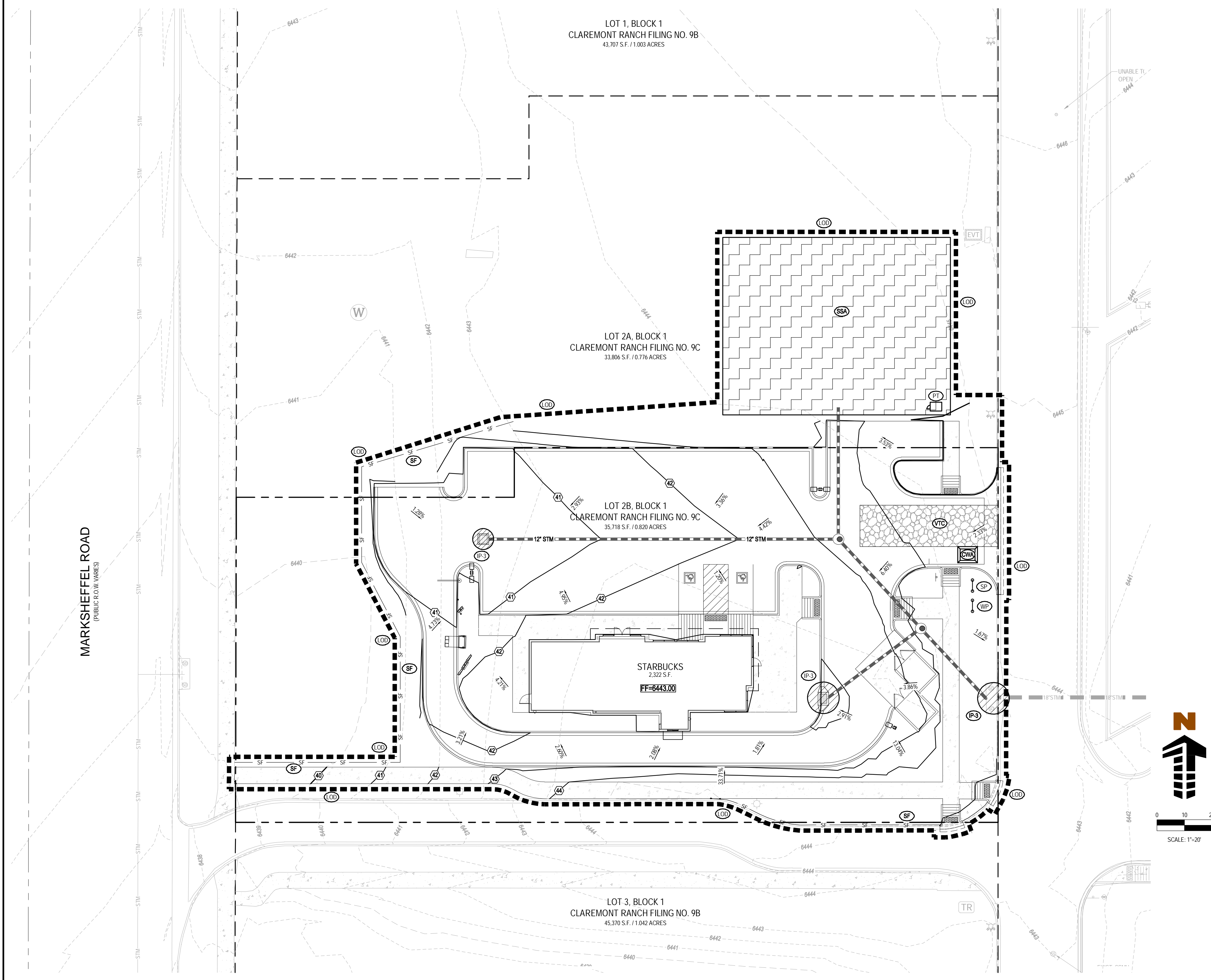

GRADING LEGEND

- PROPERTY BOUNDARY LINE
- ADJACENT PROPERTY BOUNDARY LINE
- EASEMENT BOUNDARY LINE
- PROPOSED MAJOR CONTOUR
- PROPOSED MINOR CONTOUR
- EXISTING MAJOR CONTOUR
- EXISTING MINOR CONTOUR
- EXISTING STORM SEWER
- PROPOSED STORM SEWER
- FINISHED FLOOR
- EXISTING MAN-HOLE
- PROPOSED MAN-HOLE
- PROPOSED INLETS

EROSION CONTROL LEGEND

- LIMITS OF DISTURBANCE (0.897 AC)
- FLOW ARROW
- CONSTRUCTION VEHICLE ENTRY
- SILT FENCE
- CONCRETE WASHOUT
- STABILIZED STAGING AREA
- IP-1 - FILTER FABRIC INLET PROTECTION
- IP-3 - ROCK SOCK AREA INLET PROTECTION
- SITE POSTING (CONTACTS AND PERMITS)
- WASHOUT POSTING
- PORTABLE TOILET

COPYRIGHT
 THESE PLANS ARE AN INSTRUMENT OF SERVICE AND ARE THE PROPERTY OF GALLOWAY, AND MAY NOT BE DUPLICATED, DISCLOSED, OR REPRODUCED WITHOUT THE WRITTEN CONSENT OF GALLOWAY. COPYRIGHTS AND INFRINGEMENTS WILL BE ENFORCED AND PROSECUTED.

**CLAREMONT RANCH
 FILING NO. 9C
 LOT 2B, BLOCK 1**

**CONSTITUTION AND MARKSHEFFEL
 EL PASO COUNTY, COLORADO**

| # | Date | Issue / Description | Init. |
|---|------------|---------------------|-------|
| 1 | 12/22/2017 | 2nd SUBMITTAL | RDG |
| | | | |
| | | | |
| | | | |
| | | | |
| | | | |
| | | | |
| | | | |
| | | | |
| | | | |

| | |
|-------------|-----------|
| Project No: | ED1000040 |
| Drawn By: | RDG |
| Checked By: | BMR |
| Date: | 11/17/17 |

GRADING AND EROSION CONTROL PLAN

C2.1

© 2017 Galloway & Company, Inc. All Rights Reserved. 11/17/17

Appendix B

(Erosion Control Details)

CLAREMONT RANCH FILING NO. 9C

LOT 2B, BLOCK 1

A PORTION OF SECTION 4, TOWNSHIP 14 SOUTH, RANGE 65 WEST OF THE 6TH P.M., EL PASO COUNTY, COLORADO

GRADING AND EROSION CONTROL PLAN

EL PASO COUNTY GRADING AND EROSION CONTROL NOTES

- CONSTRUCTION SHALL NOT COMMENCE UNTIL A CONSTRUCTION PERMIT IS OBTAINED FROM DEVELOPMENT SERVICES AND A PRECONSTRUCTION CONFERENCE IS HELD WITH DEVELOPMENT SERVICES.
- STORMWATER DISCHARGES FROM CONSTRUCTION SITES SHALL NOT CAUSE OR THREATEN TO CAUSE POLLUTION, CONTAMINATION, OR DEGRADATION OF STATE WATERS. ALL WORK AND EARTH DISTURBANCE SHALL BE DONE IN A MANNER THAT MINIMIZES POLLUTION OF ANY ON-SITE OR OFF-SITE WATERS, INCLUDING WETLANDS.
- NOTWITHSTANDING ANYTHING DEPICTED IN THESE PLANS IN WORDS OR GRAPHIC REPRESENTATION, ALL DESIGN AND CONSTRUCTION RELATED TO ROADS, STORM DRAINAGE AND EROSION CONTROL SHALL CONFORM TO THE STANDARDS AND REQUIREMENTS OF THE MOST RECENT EDITION OF THE EL PASO COUNTY STANDARDS, INCLUDING THE LAND DEVELOPMENT CODE, THE ENGINEERING CRITERIA MANUAL, THE DRAINAGE CRITERIA MANUAL, AND THE DRAINAGE CRITERIA MANUAL VOLUME 2. ANY DEVIATIONS TO REGULATIONS AND STANDARDS MUST BE REQUESTED, AND APPROVED, IN WRITING.
- A SEPARATE STORMWATER MANAGEMENT PLAN (SWMP) FOR THIS PROJECT SHALL BE COMPLETED AND AN EROSION AND STORMWATER QUALITY CONTROL PERMIT (ESQCP) ISSUED PRIOR TO COMMENCING CONSTRUCTION. DURING CONSTRUCTION THE SWMP IS THE RESPONSIBILITY OF THE DESIGNATED STORMWATER MANAGER. SHALL BE LOCATED ON SITE AT ALL TIMES AND SHALL BE KEPT UP TO DATE WITH WORK PROGRESS AND CHANGES IN THE FIELD.
- ONCE THE ESQCP HAS BEEN ISSUED, THE CONTRACTOR MAY INSTALL THE INITIAL STAGE EROSION AND SEDIMENT CONTROL BMPs AS INDICATED ON THE EEC. A PRECONSTRUCTION MEETING BETWEEN THE CONTRACTOR, ENGINEER, AND EL PASO COUNTY WILL BE HELD PRIOR TO ANY CONSTRUCTION. IT IS THE RESPONSIBILITY OF THE APPLICANT TO COORDINATE THE MEETING TIME AND PLACE WITH COUNTY DSD INSPECTIONS STAFF.
- SOIL EROSION CONTROL MEASURES FOR ALL SLOPES, CHANNELS, DITCHES, OR ANY DISTURBED LAND AREA SHALL BE COMPLETED WITHIN 21 CALENDAR DAYS AFTER FINAL GRADING OR FINAL EARTH DISTURBANCE HAS BEEN COMPLETED. DISTURBED AREAS AND STOCKPILES WHICH ARE NOT AT FINAL GRADE BUT WILL REMAIN DORMANT FOR LONGER THAN 30 DAYS SHALL ALSO BE MULCHED WITHIN 21 DAYS AFTER INTERIM GRADING. AN AREA THAT IS GOING TO REMAIN AN INTERIM STATE FOR MORE THAN 60 DAYS SHALL ALSO BE SEEDED. ALL TEMPORARY SOIL EROSION CONTROL MEASURES AND BMPs SHALL BE MAINTAINED UNTIL PERMANENT SOIL EROSION CONTROL MEASURES ARE IMPLEMENTED AND ESTABLISHED.
- TEMPORARY SOIL EROSION CONTROL FACILITIES SHALL BE REMOVED AND EARTH DISTURBANCE AREAS GRADED AND STABILIZED WITH PERMANENT SOIL EROSION CONTROL MEASURES PURSUANT TO STANDARDS AND SPECIFICATION PRESCRIBED IN THE DCM VOLUME II AND THE ENGINEERING CRITERIA MANUAL APPENDIX.
- ALL PERSONS ENGAGED IN EARTH DISTURBANCE SHALL IMPLEMENT AND MAINTAIN ACCEPTABLE SOIL EROSION AND SEDIMENT CONTROL MEASURES INCLUDING BMPs IN CONFORMANCE WITH THE EROSION CONTROL TECHNICAL STANDARDS OF THE ENGINEERING CRITERIA MANUAL (DCM) VOLUME II AND IN ACCORDANCE WITH THE STORMWATER MANAGEMENT PLAN (SWMP).
- ALL TEMPORARY EROSION CONTROL FACILITIES INCLUDING BMPs AND ALL PERMANENT FACILITIES INTENDED TO CONTROL EROSION OF ANY EARTH DISTURBANCE OPERATIONS SHALL BE INSTALLED AS DEFINED IN THE APPROVED PLANS, THE SWMP AND THE DCM VOLUME II AND MAINTAINED THROUGHOUT THE DURATION OF THE EARTH DISTURBANCE OPERATION.
- ANY EARTH DISTURBANCE SHALL BE CONDUCTED IN SUCH A MANNER SO AS TO EFFECTIVELY REDUCE ACCELERATED SOIL EROSION AND RESULTING SEDIMENTATION. ALL DISTURBANCES SHALL BE DESIGNED, CONSTRUCTED, AND COMPLETED SO THAT THE EXPOSED AREA OF ANY DISTURBED LAND SHALL BE LIMITED TO THE SHORTEST PRACTICAL PERIOD OF TIME.
- ANY TEMPORARY OR PERMANENT FACILITY DESIGNED AND CONSTRUCTED FOR THE CONVEYANCE OF STORMWATER AROUND, THROUGH, OR FROM THE EARTH DISTURBANCE AREA SHALL BE DESIGNED TO LIMIT THE DISCHARGE TO A NON-EROSIVE VELOCITY.
- CONCRETE WASH WATER SHALL BE CONTAINED AND DISPOSED OF IN ACCORDANCE WITH THE SWMP. NO WASH WATER SHALL BE DISCHARGED TO OR ALLOWED TO RUNOFF TO STATE WATERS, INCLUDING ANY SURFACE OR SUBSURFACE STORM DRAINAGE SYSTEM OR FACILITIES.
- EROSION CONTROL BLANKETING IS TO BE USED ON SLOPES STEEPER THAN 3:1.
- BUILDING, CONSTRUCTION, EXCAVATION, OR OTHER WASTE MATERIALS SHALL NOT BE TEMPORARILY PLACED OR STORED IN THE STREET, ALLEY, OR OTHER PUBLIC WAY, UNLESS IN ACCORDANCE WITH AN APPROVED TRAFFIC CONTROL PLAN. BMPs MAY BE REQUIRED BY EL PASO COUNTY ENGINEERING IF DEEMED NECESSARY, BASED ON SPECIFIC CONDITIONS AND CIRCUMSTANCES.
- VEHICLE TRACKING CONTROL AND CONSTRUCTION DEBRIS OFF-SITE SHALL BE MINIMIZED. MATERIALS TRACKED OFF-SITE SHALL BE CLEANED UP AND PROPERLY DISPOSED OF IMMEDIATELY.
- CONTRACTOR SHALL BE RESPONSIBLE FOR THE REMOVAL OF ALL WASTES FROM THE CONSTRUCTION SITE FOR DISPOSAL IN ACCORDANCE WITH LOCAL AND STATE REGULATORY REQUIREMENTS. NO CONSTRUCTION DEBRIS, TREE SLASH, BUILDING MATERIAL WASTES OR UNUSED BUILDING MATERIALS SHALL BE BURIED, DUMPED, OR DISCHARGED AT THE SITE.
- THE OWNER, SITE DEVELOPER, CONTRACTOR, AND/OR THEIR AUTHORIZED AGENTS SHALL BE RESPONSIBLE FOR THE REMOVAL OF ALL CONSTRUCTION DEBRIS, DIRT, TRACK, ROCK, SEDIMENT AND SAND THAT MAY ACCUMULATE IN THE STORM SEWER OR OTHER DRAINAGE CONVEYANCE SYSTEM AND STORMWATER APPURTENANCES AS A RESULT OF SITE DEVELOPMENT.
- THE QUANTITY OF MATERIALS STORED ON THE PROJECT SITE SHALL BE LIMITED AS MUCH AS PRACTICAL TO THAT QUANTITY REQUIRED TO PERFORM THE WORK IN AN ORDERLY SEQUENCE. ALL MATERIALS STORED ON-SITE SHALL BE STORED IN NEAT, ORDERLY MANNER, IN THEIR ORIGINAL CONTAINERS, WITH ORIGINAL MANUFACTURER'S LABELS.
- NO CHEMICALS ARE TO BE USED BY THE CONTRACTOR, WHICH HAVE THE POTENTIAL TO BE RELEASED IN STORMWATER UNLESS PERMISSION FOR THE USE OF A SPECIFIC CHEMICAL IS GRANTED IN WRITING BY THE ECM ADMINISTRATOR. IN GRANTING THE USE OF SUCH CHEMICALS, SPECIAL CONDITIONS AND MONITORING MAY BE REQUIRED.
- BULK STORAGE STRUCTURES FOR PETROLEUM PRODUCTS AND OTHER CHEMICALS SHALL HAVE ADEQUATE PROTECTION SO AS TO CONTAIN ALL SPILLS AND PREVENT ANY SPILLED MATERIAL FROM ENTERING STATE WATERS, INCLUDING ANY SURFACE OR SUBSURFACE STORM DRAINAGE SYSTEM OR FACILITIES.
- NO PERSON SHALL CAUSE THE IMPEDIMENT OF STORMWATER FLOW IN THE FLOWLINE OF THE CURB AND GUTTER OR IN THE DITCHLINE.
- INDIVIDUALS SHALL COMPLY WITH THE "COLORADO WATER QUALITY CONTROL ACT" (TITLE 25, ARTICLE 8, CRS), AND THE "CLEAN WATER ACT" (33 USC 1344), IN ADDITION TO THE REQUIREMENTS INCLUDED IN THE DCM VOLUME II AND THE ECM APPENDIX I. ALL APPROPRIATE PERMITS MUST BE OBTAINED BY THE CONTRACTOR PRIOR TO CONSTRUCTION (NPDES, FLOODPLAIN, 404, FUGITIVE DUST, ETC.). IN THE EVENT OF CONFLICTS BETWEEN THESE REQUIREMENTS AND LAWS, RULES, OR REGULATIONS OF OTHER FEDERAL, STATE, OR COUNTY AGENCIES, THE MORE RESTRICTIVE LAWS, RULES, OR REGULATIONS SHALL APPLY.
- ALL CONSTRUCTION TRAFFIC MUST ENTER/EXIT THE SITE AT APPROVED CONSTRUCTION ACCESS POINTS.
- PRIOR TO ACTUAL CONSTRUCTION THE PERMITEE SHALL VERIFY THE LOCATION OF EXISTING UTILITIES.
- A WATER SOURCE SHALL BE AVAILABLE ON SITE DURING EARTHWORK OPERATIONS AND UTILIZED AS REQUIRED TO MINIMIZE DUST FROM EARTHWORK EQUIPMENT AND WIND.
- THE SOILS REPORT FOR THIS SITE HAS BEEN PREPARED BY GROUND ENGINEERING (JOB #: 15-3527, DATED JUNE 12, 2015) AND SHALL BE CONSIDERED A PART OF THESE PLANS.
- AT LEAST TEN DAYS PRIOR TO THE ANTICIPATED START OF CONSTRUCTION FOR PROJECTS THAT WILL DISTURB 1 ACRE OR MORE, THE OWNER OR OPERATOR OF CONSTRUCTION ACTIVITY SHALL SUBMIT A PERMIT APPLICATION FOR STORMWATER DISCHARGE TO THE COLORADO DEPARTMENT OF PUBLIC HEALTH AND ENVIRONMENT, WATER QUALITY DIVISION. THE APPLICATION CONTAINS CERTIFICATION OF COMPLETION OF A STORMWATER MANAGEMENT PLAN (SWMP), OF WHICH THIS GRADING AND EROSION CONTROL PLAN MAY BE A PART. FOR INFORMATION OR APPLICATION MATERIALS CONTACT COLORADO DEPARTMENT OF PUBLIC HEALTH AND ENVIRONMENT WATER QUALITY CONTROL DIVISION
 WQCD - PERMITS
 4300 CHERRY CREEK DRIVE SOUTH
 DENVER, CO 80246-1530
 ATTN: PERMITS UNIT

COPYRIGHT

THESE PLANS ARE AN INSTRUMENT OF SERVICE AND ARE THE PROPERTY OF GALLOWAY, AND MAY NOT BE DUPLICATED, DISCLOSED, OR REPRODUCED WITHOUT THE WRITTEN CONSENT OF GALLOWAY. COPYRIGHTS AND INFRINGEMENTS WILL BE ENFORCED AND PROSECUTED.

CLAREMONT RANCH FILING NO. 9C LOT 2B, BLOCK 1
 CONSTITUTION AND MARKSHEFFEL EL PASO COUNTY, COLORADO

CLAREMONT RANCH FILING NO. 9C LOT 2B, BLOCK 1

MANAGEMENT STRATEGIES

- VEHICLE TRACKING CONTROL SHALL BE PROVIDED AND MAINTAINED THROUGHOUT THE ENTIRE DURATION OF THE PROJECT.
- THE INLET PROTECTION SHOWN ON THE ENCLOSED EROSION CONTROL PLAN SHALL BE SECURED AND PLACED ACCORDING TO THE BEST PRACTICES DETAILED IN THIS PLAN.
- THE CONSTRUCTION SUPERINTENDENT SHALL HAVE OVERALL RESPONSIBILITY FOR PLAN IMPLEMENTATION, SUPERINTENDENT RESPONSIBLE FOR SEEING THAT APPROPRIATE CONSTRUCTION WORKERS AND SUBCONTRACTORS ARE AWARE OF ALL PROVISIONS OF THE PLAN.
- CONTRACTOR SHALL ESTABLISH AND MAINTAIN STABILIZATION PERMITS FOR THE LANDSCAPING PLANS & EROSION CONTROL PLAN IN THIS SET AT THE COMPLETION OF THE PROJECT.
- CLEAN-UP:
 - TRANSPORT TRASH AND DEBRIS, AND SURPLUS AND UNACCEPTABLE SOIL MATERIALS FROM PROJECT SITE AND LEGALLY DISPOSE OF THEM.
 - REMOVE ALL TEMPORARY SHORING, BRACING, EROSION CONTROL, AND OTHER PROTECTION DEVICES WHEN NO LONGER REQUIRED BY CITY.

MAINTENANCE

IN GENERAL, ALL EROSION AND SEDIMENT CONTROL MEASURES WILL BE CHECKED WEEKLY AND AFTER EACH SIGNIFICANT RAINFALL. THE FOLLOWING ITEMS WILL BE CHECKED IN PARTICULAR:

- THE CONSTRUCTION ENTRANCE SHALL BE MAINTAINED IN A CONDITION WHICH WILL PREVENT TRACKING AND FLOW OF MUD ONTO PUBLIC RIGHTS-OF-WAY. ALL MATERIALS SPILLED, DROPPED, WASHED, OR TRACKED FROM VEHICLE OR SITE ONTO ROADWAY MUST BE REMOVED IMMEDIATELY.
- GRAVEL FILTERS, GRAVEL SOCKS OR OTHER INLET PROTECTION WILL BE CHECKED REGULARLY FOR SEDIMENTATION BUILDUP AND CLEANED AS REQUIRED.

PERFORMANCE STANDARDS

THE GENERAL REQUIREMENTS FOR EROSION CONTROL WORK SHALL BE AS FOLLOWS:

- ANY LAND DISTURBING ACTIVITY SHALL BE CONDUCTED IN SUCH A MANNER SO AS TO EFFECTIVELY REDUCE ACCELERATED SOIL EROSION AND RESULTING SEDIMENTATION.
- STRUCTURAL EROSION CONTROL MEASURES INCLUDED IN THE APPROVED PLAN ARE TO BE INSTALLED PRIOR TO SOIL DISTURBANCE. INSTALLATION WILL MEET SPECIFICATIONS SHOWN ON THE DETAIL SHEET. CONTROL MEASURES NECESSARY FOR CONTINUING PHASES OF CONSTRUCTION SHALL BE INSTALLED AS DETAILED IN THE SUBMITTED CONSTRUCTION SCHEDULE OR AS NEEDED IN PROGRESSION TO THE FINAL EROSION CONTROL PLAN.
- ALL LAND DISTURBING ACTIVITIES SHALL BE DESIGNED, CONSTRUCTED AND COMPLETED IN SUCH A MANNER THAT THE EXPOSURE TIME OF DISTURBED LAND SHALL BE LIMITED TO THE SHORTEST POSSIBLE PERIOD OF TIME.
- SEDIMENT CAUSED BY ACCELERATED SOIL EROSION SHALL BE REMOVED FROM RUNOFF WATER BEFORE LEAVING THE SITE.
- ANY TEMPORARY OR PERMANENT FACILITY DESIGNED AND CONSTRUCTED FOR THE CONVEYANCE OF WATER AROUND, THROUGH OR FROM THE LAND DISTURBING ACTIVITY SHALL BE DESIGNED TO LIMIT THE WATER FLOW TO A NON-EROSIVE VELOCITY.
- TEMPORARY SOIL EROSION CONTROL FACILITIES SHALL BE REMOVED AND AREAS OF LAND DISTURBANCE GRADED AND STABILIZED WITH PERMANENT SOIL EROSION CONTROL MEASURES PURSUANT TO APPROVED PLANS AND SPECIFICATIONS.
- THE PERMITEE IS RESPONSIBLE FOR MAINTENANCE OF ALL EROSION CONTROL STRUCTURES. THESE STRUCTURES ARE TO BE INSPECTED BY THE PERMITEE EVERY 14 DAYS AND AFTER EVERY PRECIPITATION EVENT TO INSURE THEIR EFFICIENCY AND TO EVALUATE MAINTENANCE NEEDS OR PER LOCAL INSPECTION REQUIREMENTS. MAINTENANCE OF THESE STRUCTURES MAY BE DIRECTED AT ANY TIME BY A CITY OR STATE REPRESENTATIVE.
- THESE STANDARDS DO NOT SUPPLANT ANY CITY, STATE OR FEDERAL REQUIREMENTS. CONTRACTOR SHALL ALWAYS ADHERE TO THE STRICTER STANDARD SHOULD ANY DISCREPANCY ARISE.

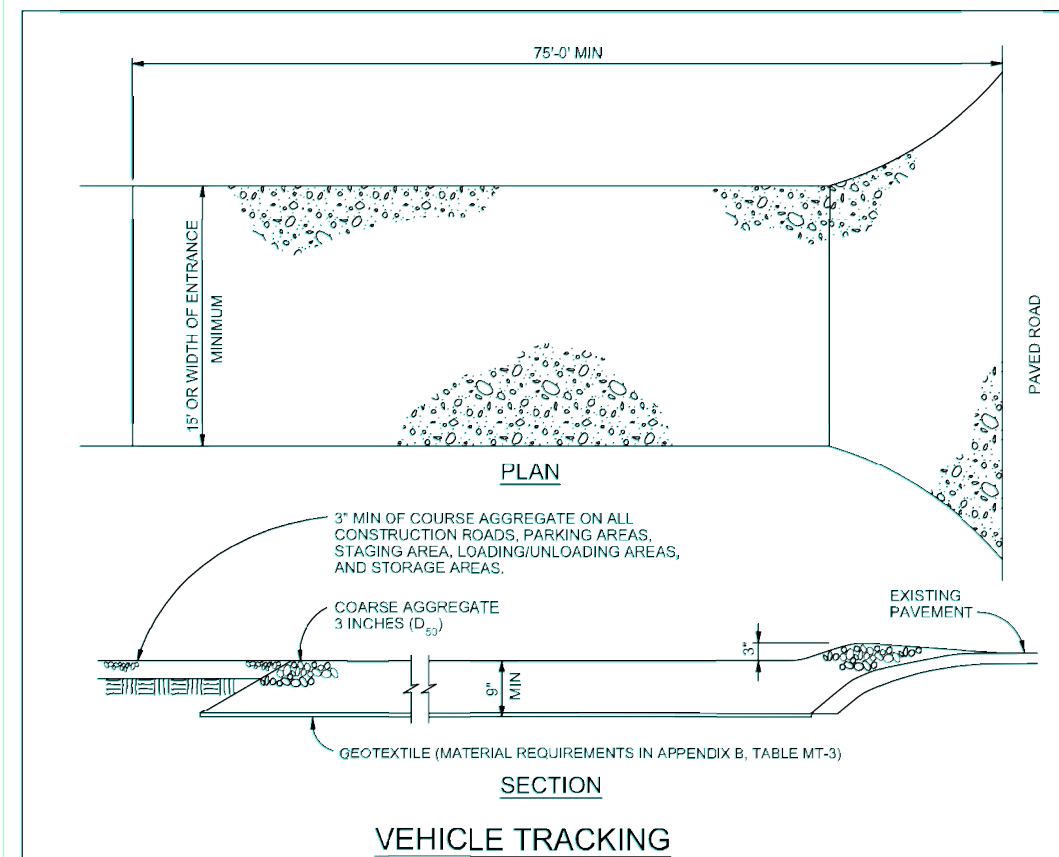

VEHICLE TRACKING NOTES

INSTALLATION REQUIREMENTS

- ALL ENTRANCES TO THE CONSTRUCTION SITE ARE TO BE STABILIZED PRIOR TO CONSTRUCTION BEGINNING.
- CONSTRUCTION ENTRANCES ARE TO BE BUILT WITH AN AMPHIBIOUS CURB FOR TURNING TRAFFIC, BUT SHOULD NOT BE BUILT OVER EXISTING PAVEMENT EXCEPT FOR A SURT CHOKER.
- AREAS TO BE STABILIZED ARE TO BE PROPERLY GRADED AND COMPACTED PRIOR TO LAYING DOWN GEOTEXTILE AND STONE.
- CONSTRUCTION ROADS, PARKING AREAS, LOADING/UNLOADING ZONES, STORAGE AREAS, AND STAGING AREAS ARE TO BE STABILIZED.
- CONSTRUCTION ROADS ARE TO BE BUILT TO CONFORM TO SITE GRADING, BUT SHOULD NOT HAVE SIDE SLOPES OR ROAD GRADATIONS THAT ARE EXCESSIVELY STEEP.

MAINTENANCE REQUIREMENTS

- REGULAR INSPECTIONS ARE TO BE MADE OF ALL STABILIZED AREAS, ESPECIALLY AFTER STORM EVENTS.
- STONES ARE TO BE REPLACED PERIODICALLY AND WHEN REPAIR IS NECESSARY.
- SEDIMENT TRACKED ONTO PAVED SURFACES IS TO BE REMOVED DAILY BY SWEEPING OR BLOWING. SEDIMENT IS NOT TO BE WASHED DOWN STORM SEWER DRAINS.
- STORM DRAINAGE PROTECTION IS TO BE IN PLACE, INSPECTED, AND CLEANED AS NECESSARY.
- OTHER ASSOCIATED SEDIMENT CONTROL MEASURES ARE TO BE INSPECTED TO ENSURE GOOD WORKING CONDITION.

| | Case 1 | Case 2 |
|------------------|--------|--------|
| Gravel Thickness | 6" | 3" |
| Filter Fabric | YES | NO |

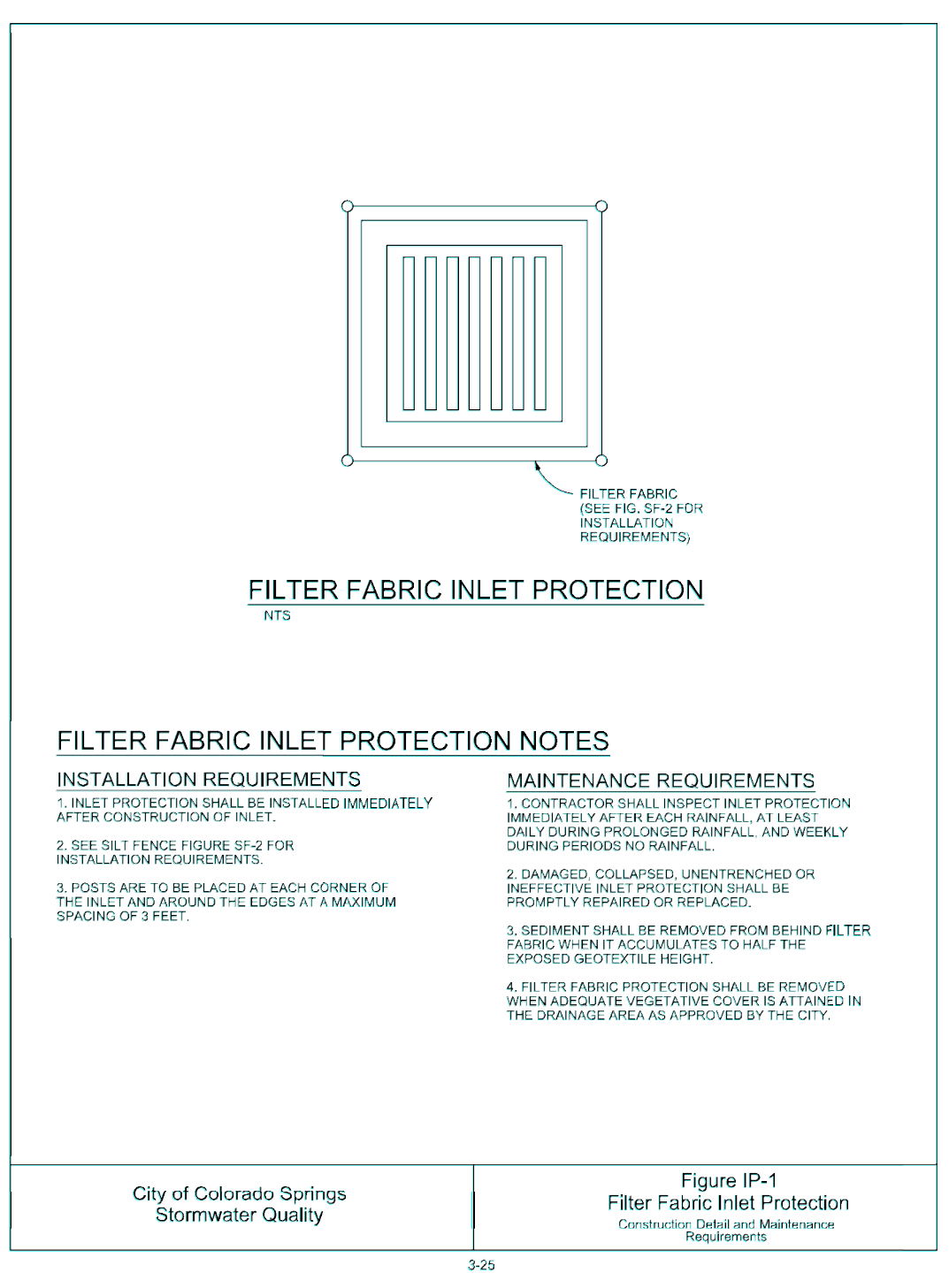
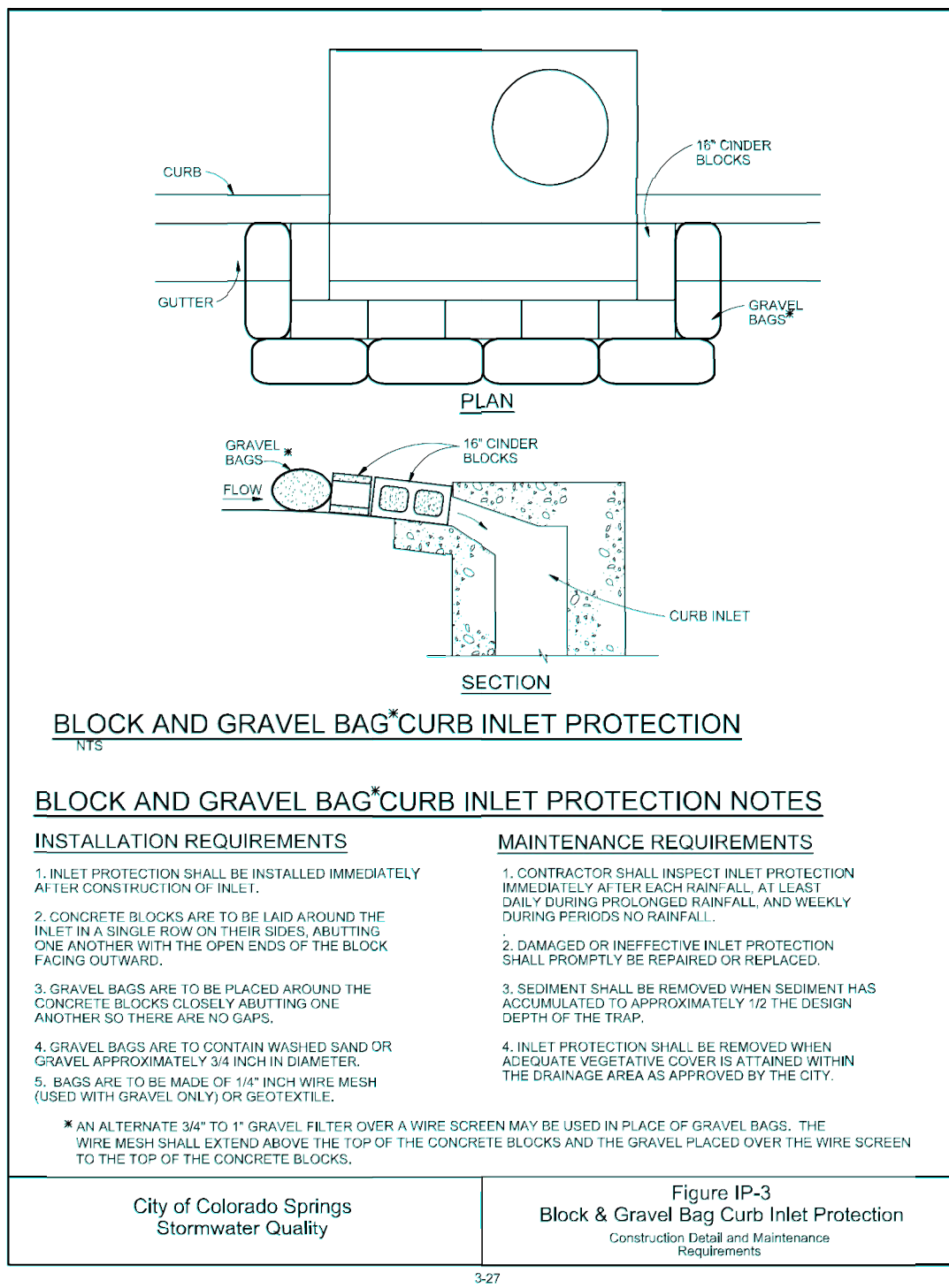
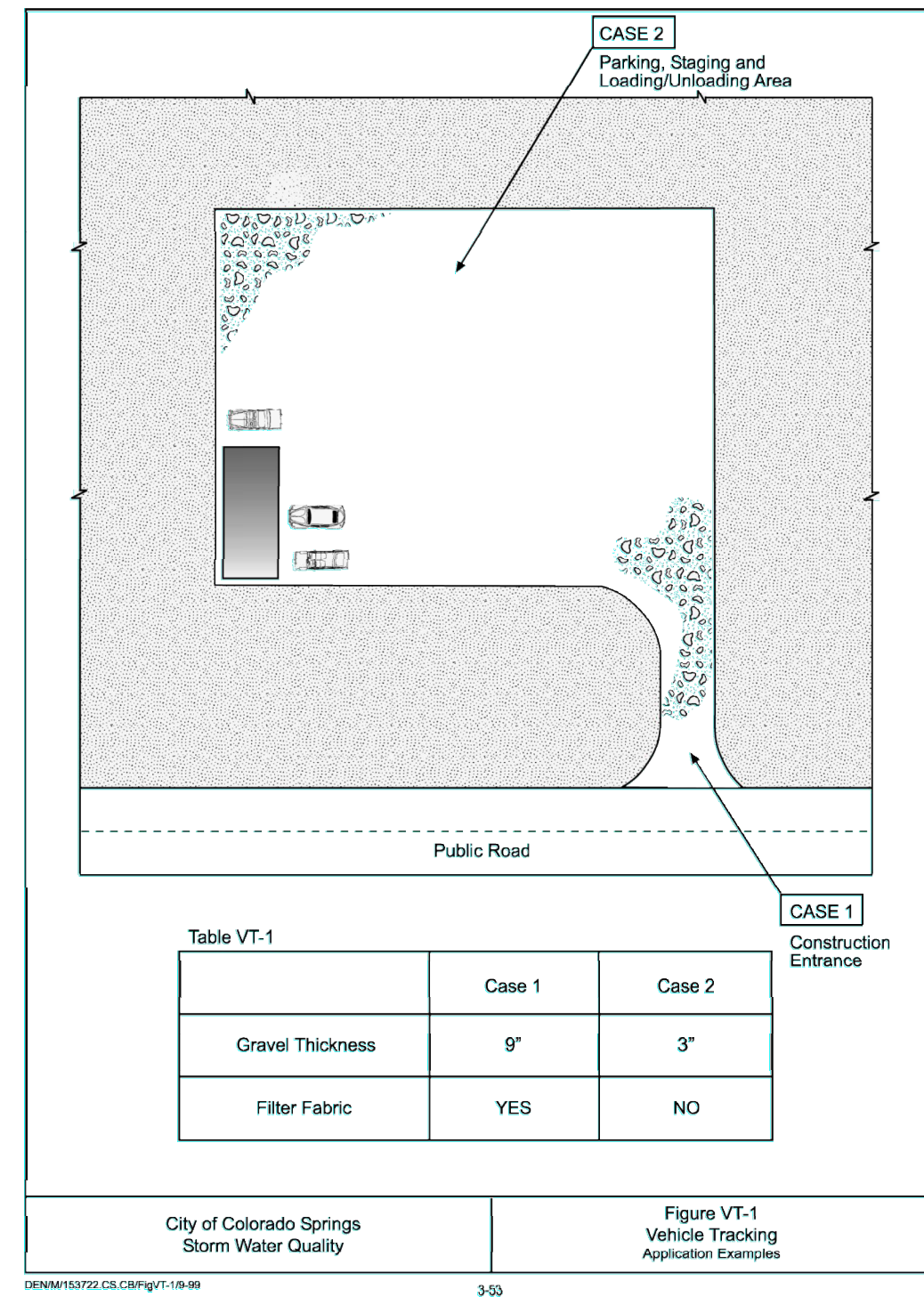

| # | Date | Issue / Description | Int. |
|----|-----------|---------------------|------|
| 1 | 1/22/2017 | 2nd SUBMITTAL | RDG |
| 2 | | | |
| 3 | | | |
| 4 | | | |
| 5 | | | |
| 6 | | | |
| 7 | | | |
| 8 | | | |
| 9 | | | |
| 10 | | | |
| 11 | | | |
| 12 | | | |
| 13 | | | |
| 14 | | | |
| 15 | | | |
| 16 | | | |
| 17 | | | |
| 18 | | | |
| 19 | | | |
| 20 | | | |
| 21 | | | |
| 22 | | | |
| 23 | | | |
| 24 | | | |
| 25 | | | |
| 26 | | | |
| 27 | | | |

GRADING AND EROSION CONTROL DETAILS

C2.2

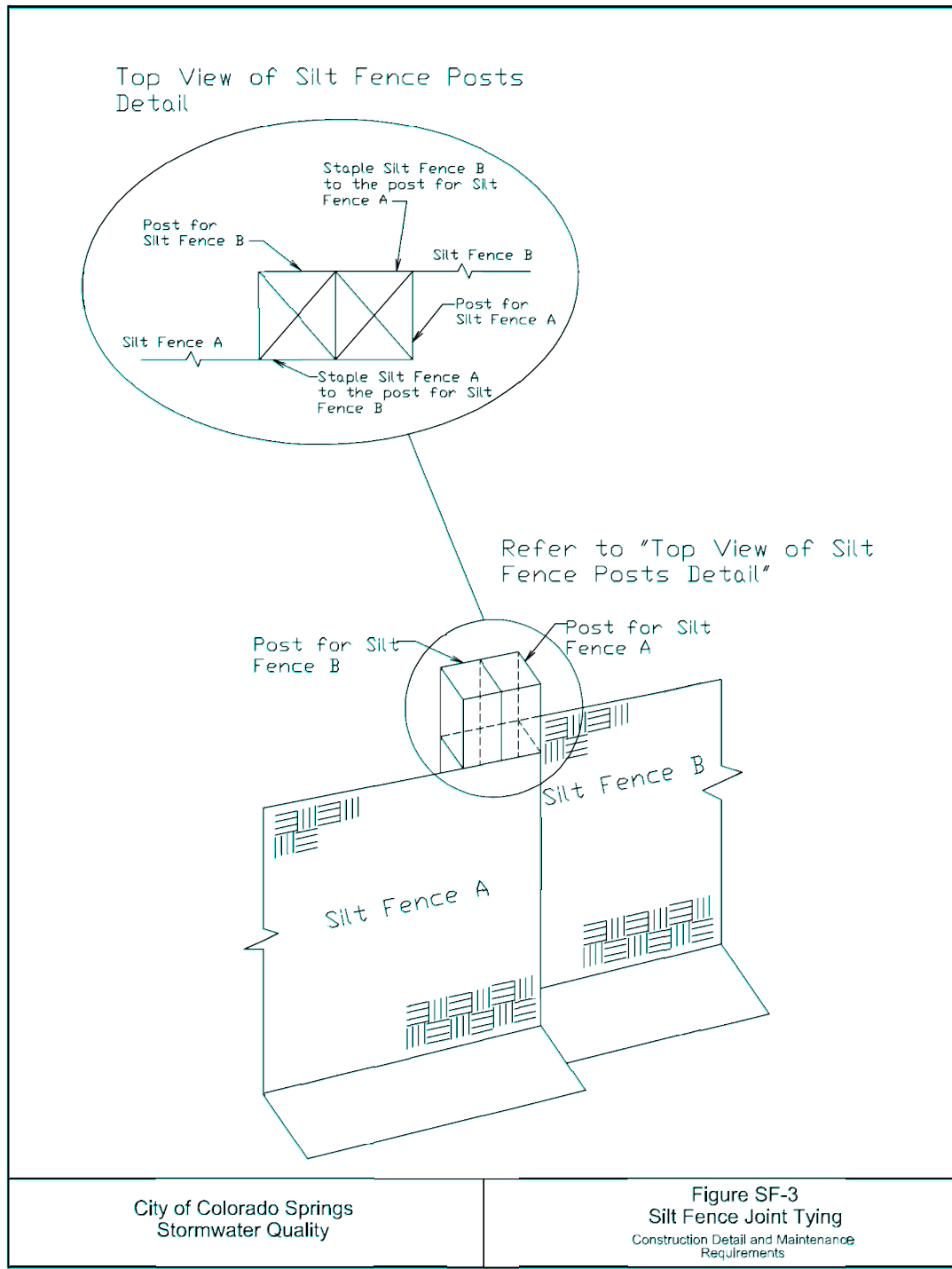
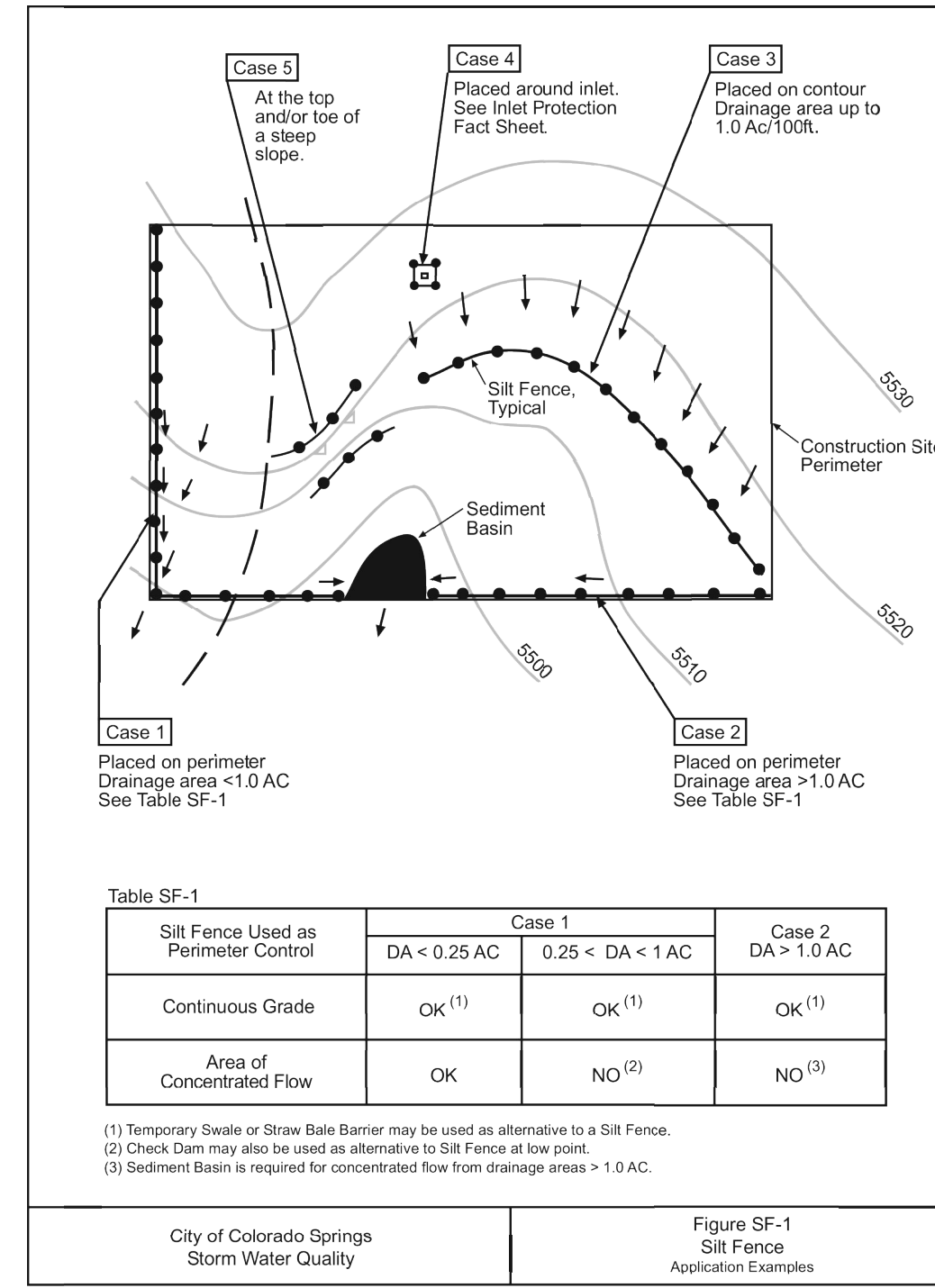
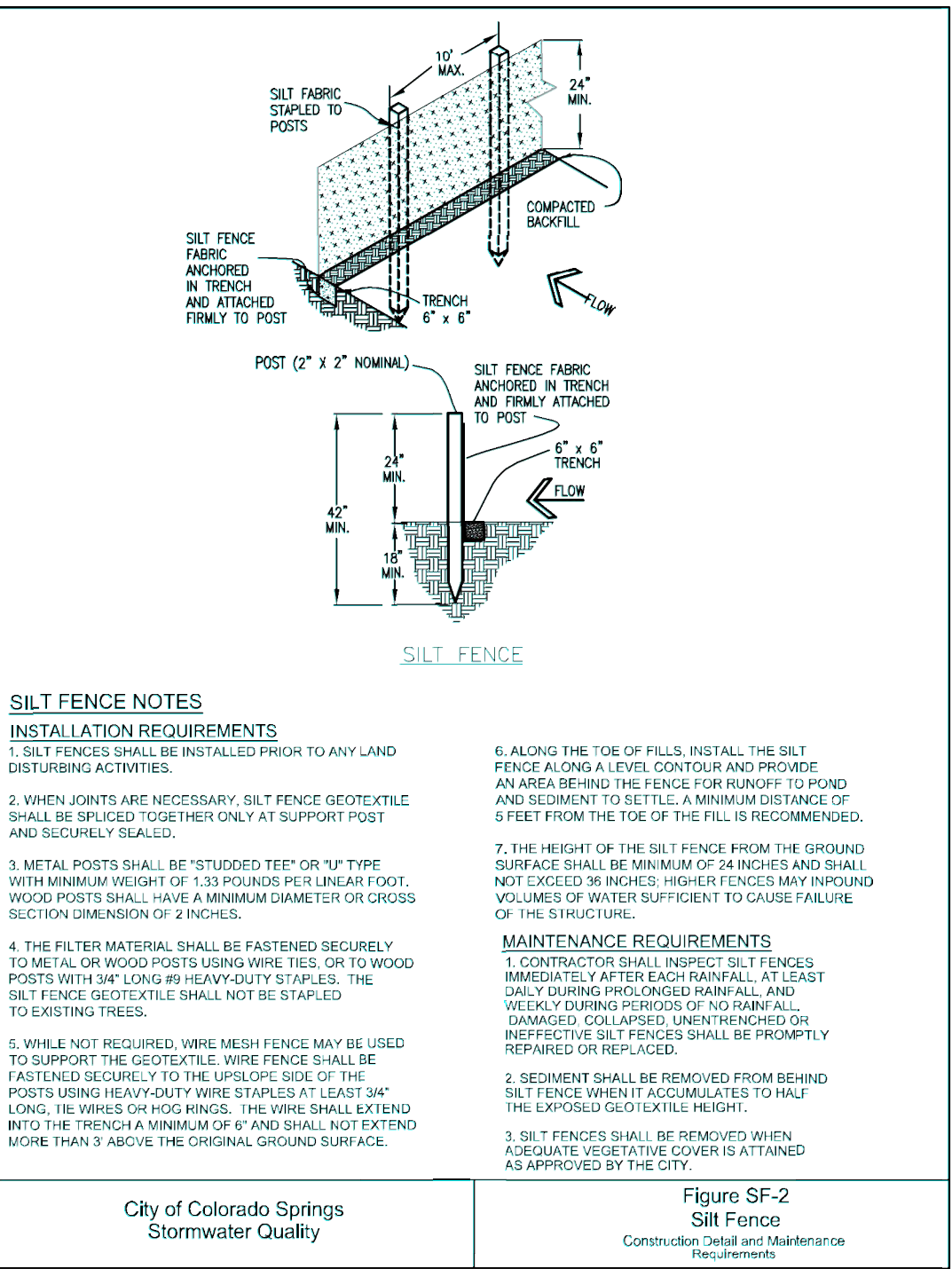

SILT FENCE NOTES

INSTALLATION REQUIREMENTS

- SILT FENCES SHALL BE INSTALLED PRIOR TO ANY LAND DISTURBING ACTIVITIES.
- WHEN JOINTS ARE NECESSARY, SILT FENCE GEOTEXTILE SHALL BE SPUNGED TOGETHER ONLY AT SUPPORT POSTS AND SECURELY SEALED.
- METAL POSTS SHALL BE STUDDED TOP OR 7/8\"/>

MAINTENANCE REQUIREMENTS

- CONTRACTOR SHALL INSPECT SILT FENCES IMMEDIATELY AFTER EACH RAINFALL. AT LEAST DAILY DURING PROLONGED RAINFALL AND WEEKLY DURING PERIODS OF NO RAINFALL. DAMAGED, COLLAPSED, UNREINFORCED OR INEFFECTIVE SILT FENCES SHALL BE PROPERLY REPAIRED OR REPLACED.
- SEDIMENT SHALL BE REMOVED FROM BEHIND SILT FENCE WHEN IT ACCUMULATES TO HALF THE HEIGHT OF THE SILT FENCE.
- SILT FENCES SHALL BE REMOVED WHEN ADEQUATE VEGETATIVE COVER IS ATTAINED AS APPROVED BY THE CITY.

Table SF-1

| Silt Fence Used as | Case 1 | | Case 2 |
|---------------------------|-------------------|-------------------|-------------------|
| | DA < 0.25 AC | 0.25 < DA < 1 AC | DA > 1.0 AC |
| Continuously Grade | OK ⁽¹⁾ | OK ⁽¹⁾ | OK ⁽¹⁾ |
| Area of Concentrated Flow | OK | NO ⁽²⁾ | NO ⁽³⁾ |

(1) Temporary Swale or Straw Bale Barrier may be used as alternative to a Silt Fence.
 (2) Check Dam may also be used as alternative to Silt Fence on steep slope.
 (3) Sediment Basin is required by concentrated flow from drainage areas > 1.0 AC.

Appendix C

(Copies of Permits/Applications)

EROSION AND STORMWATER QUALITY CONTROL PERMIT (ESQCP) EL PASO COUNTY APPLICATION AND PERMIT

PERMIT NUMBER _____

APPLICANT INFORMATION

| Applicant Contact Information | |
|--|---|
| Owner | Evergreen - Contitution & Marksheffel, LLC. |
| Name (person of responsibility) | Zach Lauterbach |
| Company/Agency | Evergreen Development |
| Position of Applicant | Developer |
| Address (physical address, not PO Box) | 2390 East Camelback Road, Suite 410 |
| City | Phoenix |
| State | Arizona |
| Zip Code | 85016 |
| Mailing address, if different from above | |
| Telephone | 602-808-8600 |
| FAX number | 602-567-7150 |
| Email Address | zlauterbach@evgre.com |
| Cellular Phone number | |

CONTRACTOR INFORMATION

| Contractor | |
|--|-----|
| Name (person of responsibility) | TBD |
| Company | |
| Address (physical address, not PO Box) | |
| City | |
| State | |
| Zip Code | |
| Mailing address, if different from above | |
| Telephone | |
| FAX number | |
| Email Address | |
| Cellular Phone number | |
| Erosion Control Supervisor (ECS)* | |
| ECS Phone number* | |
| ECS Cellular Phone number* | |

*Required for all applicants. May be provided at later date pending securing a contract when applicable.

PROJECT INFORMATION

| Project Specifications | |
|--|--|
| Project Name | Starbucks |
| Legal Description | Lot 2B, Claremont Ranch Filing No. 9B |
| Address (or nearest major cross streets) | SEC Constitution Ave. & Marksheffel Rd. |
| Acreage (total and disturbed) | Total: 0.82 acres Disturbed: 0.90 acres |
| Schedule | Start of Construction: Spring 2018 Completion of Construction: Fall 2018 Final Stabilization: Fall 2018 |
| Project Purpose | Develop a vacant commercial outlot of the existing Claremont Ranch Marketplace. |
| Description of Project | Site Development Plan to construct a ~2,322 s.f Starbucks building, with associated drives, parking and landscaping. |
| Tax Schedule Number | 5404210062 |

FOR OFFICE USE ONLY

The following signature from the ECM Administrator signifies the approval of this ESQCP. All work shall be performed in accordance with the permit, the El Paso County Engineering Criteria Manual (ECM) Standards, City of Colorado Springs Drainage Criteria Manual, Volume 2 (DCM2) as adopted by El Paso County Addendum, approved plans, and any attached conditions. The approved plans are an enforceable part of the ESQCP. Construction activity, except for the installation of initial construction BMPs is not permitted until issuance of a Construction permit and Notice to Proceed.

Signature of ECM Administrator: _____ Date _____

1.1 REQUIRED SUBMISSIONS

In addition to this completed and signed application, the following items must be submitted to obtain an ESQCP:

- Permit fees
- Stormwater Management Plan (SWMP) meeting the requirements of DCM2 and ECM either as part of the plan set or as a separate document;
- Cost estimates of construction and maintenance of construction and permanent stormwater control measures (Cost estimates shall be provided on a unit cost basis for all stormwater BMPs);
- Financial surety in an amount agreeable to the ECM Administrator based on the cost estimates of the stormwater quality protection measures provided. The financial surety shall be provided in the form of a Letter of Credit, Surety with a Bonding Company, or other forms acceptable to El Paso County;
- Operation and Maintenance Plan for any proposed permanent BMPs; and
- Signed Private Detention Basin/Stormwater Quality Best Management Practice Maintenance Agreement and Easement, if any permanent Best Management Practices are to be located on site.

1.2 RESPONSIBILITY FOR DAMAGE

The County and its officers and employees, including but not limited to the ECM Administrator, shall not be answerable or accountable in any manner, for injury to or death of any person, including but not limited to a permit holder, persons employed by the permit holder, persons acting in behalf of the permit holder, or for damage to property resulting from any activities undertaken by a permit holder or under the direction of a permit holder. The permit holder shall be responsible for any liability imposed by law and for injuries to or death of any person, including but not limited to the permit holder, persons employed by the permit holder, persons acting in behalf of the permit holder, or damage to property arising out of work or other activity permitted and done by the permit holder under a permit, or arising out of the failure on the permit holder's part to perform the obligations under any permit in respect to maintenance or any other obligations, or resulting from defects or obstructions, or from any cause whatsoever during the progress of the work, or other activity, or at any subsequent time work or other activity is being performed under the obligations provided by and contemplated by the permit.

To the extent allowed by law, the permit holder shall indemnify, save, and hold harmless the County and its officers and employees, including but not limited to the BOCC and ECM Administrator, from all claims, suits or actions of every name, kind and description brought for or on account of injuries to or death of any person, including but not limited to the permit holder, persons employed by the permit holder, persons acting in behalf of the permit holder and the public, or damage to property resulting from the performance of work or other activity under the permit, or arising out of the failure on the permit holder's part to perform his obligations under any permit in respect to maintenance or any other obligations, or resulting from defects or obstructions, or from any cause whatsoever during the progress of the work, or other activity or at any subsequent time work or other activity is being performed under the obligations provided by and contemplated by the permit, except as otherwise provided by state law. The permit holder waives any and all rights to any type of expressed or implied indemnity against the County, its officers or employees.

1.3 APPLICATION CERTIFICATION

I, as the Applicant or the representative of the Applicant, hereby certify that this application is correct and complete as per the requirements presented in this application and the El Paso County Engineering Criteria Manual and Drainage Criteria Manual, Volume 2 and El Paso County Addendum.

I, as the Applicant or the representative of the Applicant, have read and will comply with all of the requirements of the specified Stormwater Management Plan and any other documents specifying stormwater best management practices to be used on the site including permit conditions that may be required by the ECM Administrator. I understand that the Best Management Practices are to be maintained on the site and revised as necessary to protect stormwater quality as the project progresses. I further understand that a Construction Permit must be obtained and all necessary stormwater quality control BMPs are to be installed in accordance with the SWMP and the El Paso County Engineering Criteria Manual and Drainage Criteria Manual, Volume 2 and El Paso County Addendum before land disturbance begins and that failure to comply will result in a Stop Work Order and may result in other penalties as allowed by law. I further understand and agree to indemnify, save, and hold harmless the County and its officers and employees, including but not limited to the BOCC and ECM Administrator, from all claims, suits or actions of every name, kind and description as outlined in Section 1.2 Responsibility for Damage.

Date: _____

Signature of Applicant or Representative

Print Name of Applicant or Representative

Permit Fee \$ _____

Surcharge \$ _____

Financial Surety \$ _____

Type of Surety _____

Total \$ _____

Appendix D

(Stormwater Management Plan Inspection Log)

COLORADO DEPARTMENT OF TRANSPORTATION
DAILY STORMWATER LOG

In accordance with subsection 208.03(c) daily stormwater compliance inspections are required on all projects holding a Colorado Discharge Permit System – Stormwater Construction Permit (CDPS-SCP).

This form is to be used as the daily diary to evaluate BMPs used during construction activities.

See the instructions for more information.

| | | |
|-------|-----------------|---------------------|
| Date: | Project number: | Sub-account number: |
|-------|-----------------|---------------------|

The entire site shall be inspected to determine whether BMPs are being implemented and maintained in accordance with the project's site specific SWMP and the CDPS-SCP. The Erosion Control Supervisor (ECS) or Superintendent shall identify if additional BMPs are needed, can be removed, or need maintenance. The **condition** of the currently used BMPs shall be recorded, using one or more of the following letters: **(I)** Incorrect Installation; **(M)** Maintenance is needed; **(F)** BMP failed to operate; **(A)** Additional BMP is needed; **(R)** Remove BMP. Only BMPs with the conditions above need be recorded. (Use the extra page at the end of this form if needed.)

The Project Engineer will approve and the Superintendent shall direct the work associated with any BMPs identified in this daily log to ensure compliance with the site specific SWMP and the CDPS-SCP.

CDPS-SCP States: "BMPs that are not operating effectively, have proven to be inadequate, or have failed must be addressed as soon as possible, immediately in most cases."

| Location | BMP Type | Condition | Notes/Comments | Date Completed & Initials |
|----------|----------|-----------|----------------|---------------------------|
| | | | | |
| | | | | |
| | | | | |
| | | | | |
| | | | | |
| | | | | |
| | | | | |
| | | | | |

**** ALL BMPS ARE IN OPERATING CONDITION AND NO MAINTENANCE IS NEEDED.**
 (initial the box to the right when this applies)

Comments/General notes:(attach photos if necessary)

Inspection signature:

| | | |
|------------------------------------|------------|--------------|
| Superintendent or ECS Name:(Print) | Signature: | Date signed: |
|------------------------------------|------------|--------------|

Stormwater Management Field Daily Inspection Report Instructions

Inspect all erosion and sediment control BMPs throughout the entire construction site – observe, record, and determine their effectiveness. If additional BMPs are needed or any BMP is not operating effectively, it shall be recorded on this form and addressed immediately.

Location: Record the site location (e.g., project station number, mile marker, intersection quadrant, etc.).

BMP Type: Indicate the type of BMP at this location that requires attention (e.g., silt fence, erosion logs, soil retention blankets, etc.).

Condition: Identify the condition of the BMP, using one or more of the following letters: **(I)** Incorrect Installation, **(M)** Maintenance is needed (i.e., sediment needs to be removed), **(F)** BMP Failed to operate, **(A)** Additional BMP is needed, **(R)** Remove the BMP.

** If all BMPs are in operating condition and no BMP maintenance is needed, sign and initial the box to the right of the statement.

Notes/Comments: Provide the proposed corrective action needed to bring the area or BMP into compliance.

Date Completed & Initials: Date and initial when the corrective action was completed.

Inspection Signature: Sign the form when the inspection has been completed.

Place the completed daily stormwater log sheet(s) in the SWMP Notebook.

Appendix F

(Contractor Inserts)

Markup Summary

Locked (1)

December 22, 2017

[Add "PCD File No. PPR-17-053"](#)

Galloway
Health. Performance. Transformation.

Subject: Text Box

Page Label: 1

Lock: Locked

Status:

Checkmark: Unchecked

Author: dsdlaforce

Date: 1/16/2018 3:41:41 PM

Color: ■

Add "PCD File No. PPR-17-053"