

CIRCLE K - US24 & MERIDIAN FINAL PLAT OFFSITE CONSTRUCTION DOCUMENTS

A PORTION OF THE SE 1/4 OF SECTION 12, TOWNSHIP 13 SOUTH, RANGE 65 WEST OF THE 6TH P.M.
COUNTY OF EL PASO COUNTY, STATE OF COLORADO



2435 RESEARCH PARKWAY, SUITE
300 COLORADO SPRINGS, CO 80920
PHONE: (719) 575-0100



LAND DEVELOPMENT
CONSULTANTS, LLC

950 S. CHERRY ST., SUITE 512
DENVER, CO 80246

OWNER/DEVELOPER:



ROCKY MOUNTAINS DIVISION
5500 S QUEBEC STREET, SUITE 100
GREENWOOD VILLAGE, CO 80111
PHONE: (720) 758-6223

SEAL

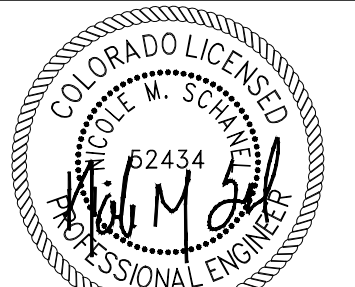

FOR AND ON BEHALF OF MATRIX DESIGN GROUP, INC
CONTRACTOR IS RESPONSIBLE FOR OBTAINING THE
MOST RECENT PROJECT CONSTRUCTION DOCUMENTS.
MATRIX DESIGN GROUP IS NOT RESPONSIBLE FOR
CHANGES, ALTERATIONS, OR USE OF CONSTRUCTION
DOCUMENTS PRIOR TO JURISDICTIONAL APPROVAL.

VICINITY MAP: NTS

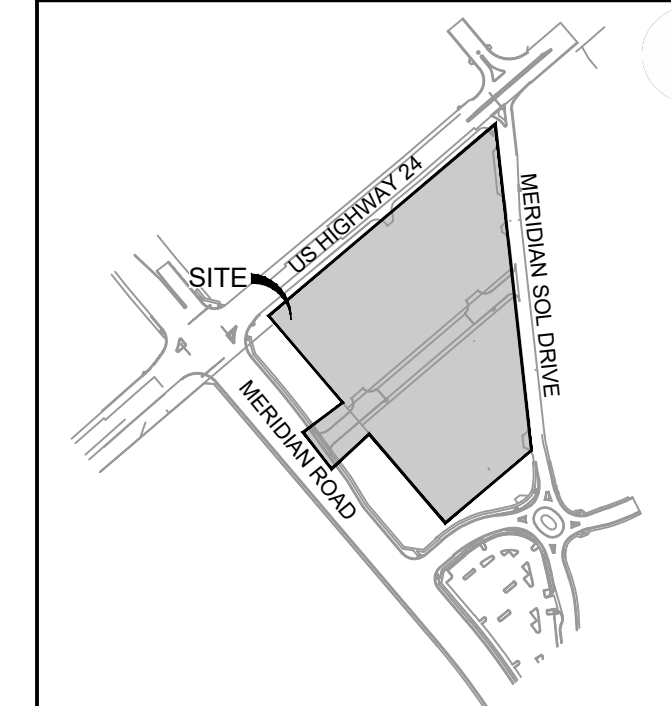

PROJECT:

CIRCLE K STORES INC.

FINAL PLAT OFFSITE CDS

CIRCLE K - US24 & MERIDIAN
FALCON, CO

REVISION HISTORY:

NO.	DATE	DESCRIPTION	BY

DRAWING INFORMATION:

PROJECT NO: 21.1207.037

DRAWN BY: RPD

CHECKED BY: NMS

DESIGNED BY: NMS

SHEET TITLE:

COVER SHEET

SHEET 1 OF 14
CS01

SHEET INDEX		
SHEET TITLE	SHEET DESCRIPTION	SHEET NUMBER
CS01	COVER SHEET	1
GN01	GENERAL NOTES	2
GN02	GENERAL NOTES	3
GN03	GENERAL NOTES	4
DM01	DEMOLITION PLAN	5
RD01	ROADWAY PLAN & PROFILE	6
RD02	ROADWAY PLAN	7
RD03	DETAILED ROAD GRADING PLAN (WEST ENTRANCE)	8
RD04	DETAILED ROAD GRADING PLAN (EAST ENTRANCE)	9
SD01	STORM DRAIN PLAN & PROFILE	10
GEC01	GRADING & EROSION CONTROL PLAN	11
ECN01	EROSION CONTROL NOTES	12
ECN02	EROSION CONTROL NOTES	13
SN01	SIGNING & STRIPING PLAN	14

BENCHMARK:

BENCHMARK: NGS DESIGNATION S 76 / PID JK0223 BRASS CAP IN CONCRETE POST STAMPED S 76 1935 LOCATED ON THE SOUTH SIDE OF HIGHWAY 94 1.1 MILES EAST OF MARKSHEFFEL ROAD AND 3' SOUTH OF THE ROW FENCE NAVD88 DATUM ELEVATION 6214.46.

SITE BM NO. 1: CENTER OF SANITARY SEWER MANHOLE LOCATED 242 FEET SOUTH OF THE SOUTH EDGE OF ASPHALT OF HIGHWAY 24 AND 9 FEET EAST OF THE EAST EDGE OF ASPHALT OF OLD MERIDIAN ROAD NAVD88 DATUM ELEVATION 6825.51.

SITE BM NO. 2: CENTER OF SANITARY SEWER MANHOLE LOCATED 861 FEET SOUTH OF THE SOUTH EDGE OF ASPHALT OF HIGHWAY 24 AND 3 FEET EAST OF THE EAST EDGE OF ASPHALT OF OLD MERIDIAN ROAD NAVD88 DATUM ELEVATION 6816.71.

BASIS OF BEARINGS:

ALL BEARINGS ARE BASED ON THE SOUTH LINE OF THE SOUTHEAST 1/4 OF SECTION 12 AS MONUMENTED BY A 3-1/4 INCH ALUMINUM CAP STAMPED "EL PASO COUNTY DPW T13S S12/S7/S13/S18 R65W R64W 1982 LS 17496" AT THE SOUTHEAST CORNER OF SECTION 12 AND BY A 3-1/4 INCH ALUMINUM CAP STAMPED "SURVCON INC. T13S R65W 1/4 S12 S13 2003 PLS 30829" AT THE SOUTH 1/4 CORNER OF SECTION 12, SAID LINE BEARS N89°50'28"W.

CONTACT LIST

OWNER
CIRCLE K STORES INC.
5500 S. QUEBEC STREET, SUITE 100
GREENWOOD VILLAGE, CO 80111
PHONE: (720) 758-6223

ELECTRICAL SERVICE
MOUNTAIN VIEW ELECTRIC ASSOCIATION
11140 E. WOODMEN ROAD
PEYTON, COLORADO 80831
PHONE: (719) 495-2283

DEVELOPER
LAND DEVELOPMENT CONSULTANTS, LLC
950 S. CHERRY ST., SUITE 512
DENVER, CO 80246
SOFIA HERNANDEZ
PHONE: (303) 717-3305

WATER & SANITARY
WOODMEN HILLS METRO DISTRICT
8046 EASTONVILLE ROAD
FALCON, CO 80831
PHONE: (719) 495-2500

CIVIL ENGINEER/ LANDSCAPE ARCHITECT
MATRIX DESIGN GROUP
2435 RESEARCH PARKWAY, SUITE 300
COLORADO SPRINGS, CO 80920
NICOLE SCHANEL/ JASON ALWINE
PHONE: (719) 575-0100

FIRE
FALCON FIRE PROTECTION DISTRICT
7030 OLD MERIDIAN ROAD
FALCON, CO 80831
PHONE: (719) 495-4050

ARCHITECT
GREENBERG FARROW
30 EXECUTIVE DRIVE, SUITE 100
IRVINE, CA 92614
DOUG COUPER
PHONE: (949) 296-0450

STORM SEWER
EL PASO COUNTY PUBLIC SERVICES
3275 AKERS DR.
COLORADO SPRINGS, COLORADO 80922
PHONE: (719) 520-6460

LAND SURVEYOR
RUBINO SURVEYING
3312 AIRPORT ROAD
BOULDER, COLORADO 80301
PHONE: (303) 464-9515

GAS
COLORADO SPRINGS UTILITIES
7710 DURANT DRIVE
COLORADO SPRINGS, COLORADO 80920
TIM BENEDICT
PHONE: (719) 688-3574

GEOTECHNICAL ENGINEER
TERRACON CONSULTANTS, INC.
4172 CENTER PARK DRIVE
COLORADO SPRINGS, CO 80916
PHONE: (719) 597-2116

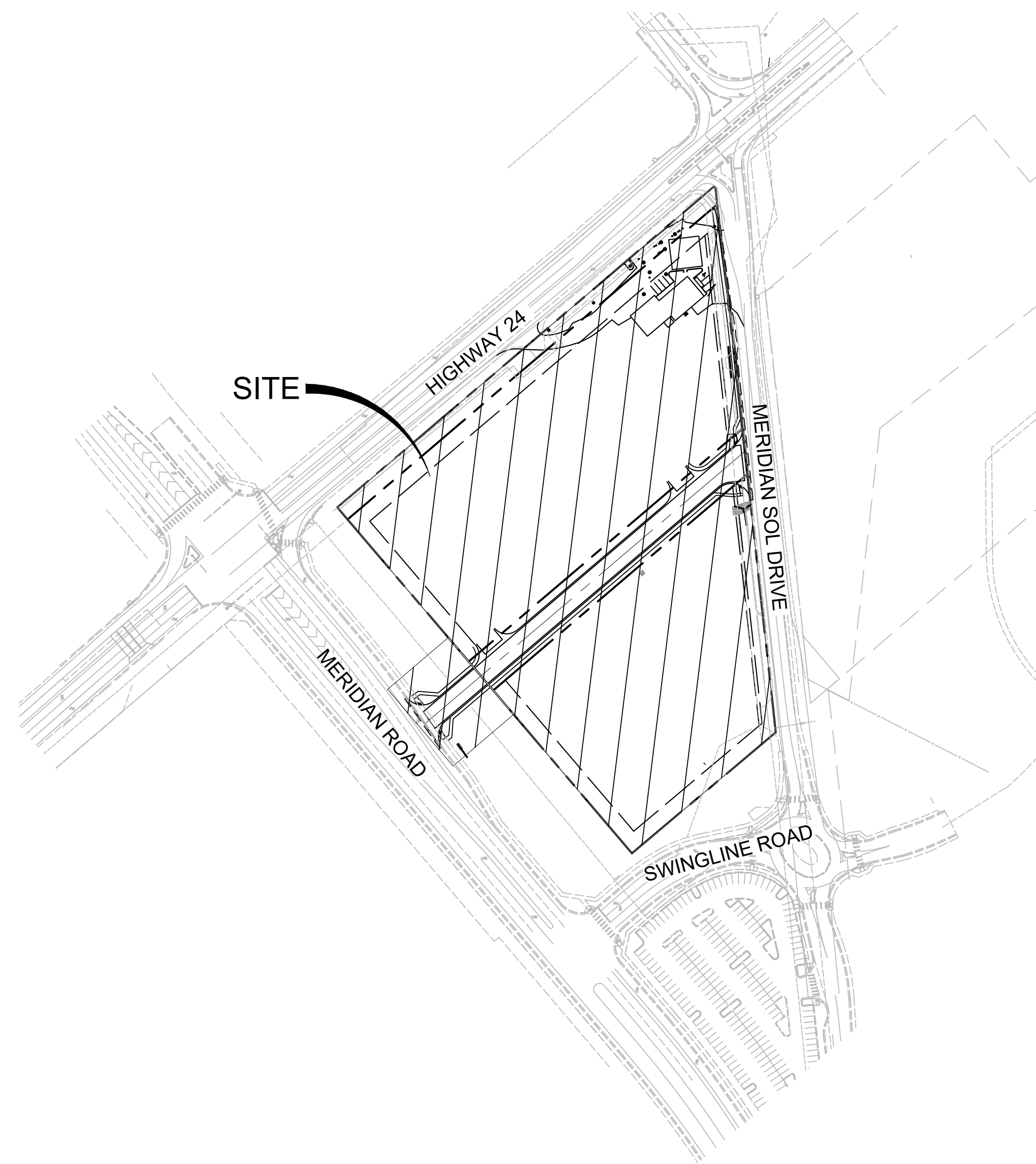

SITE MAP

1" = 150'

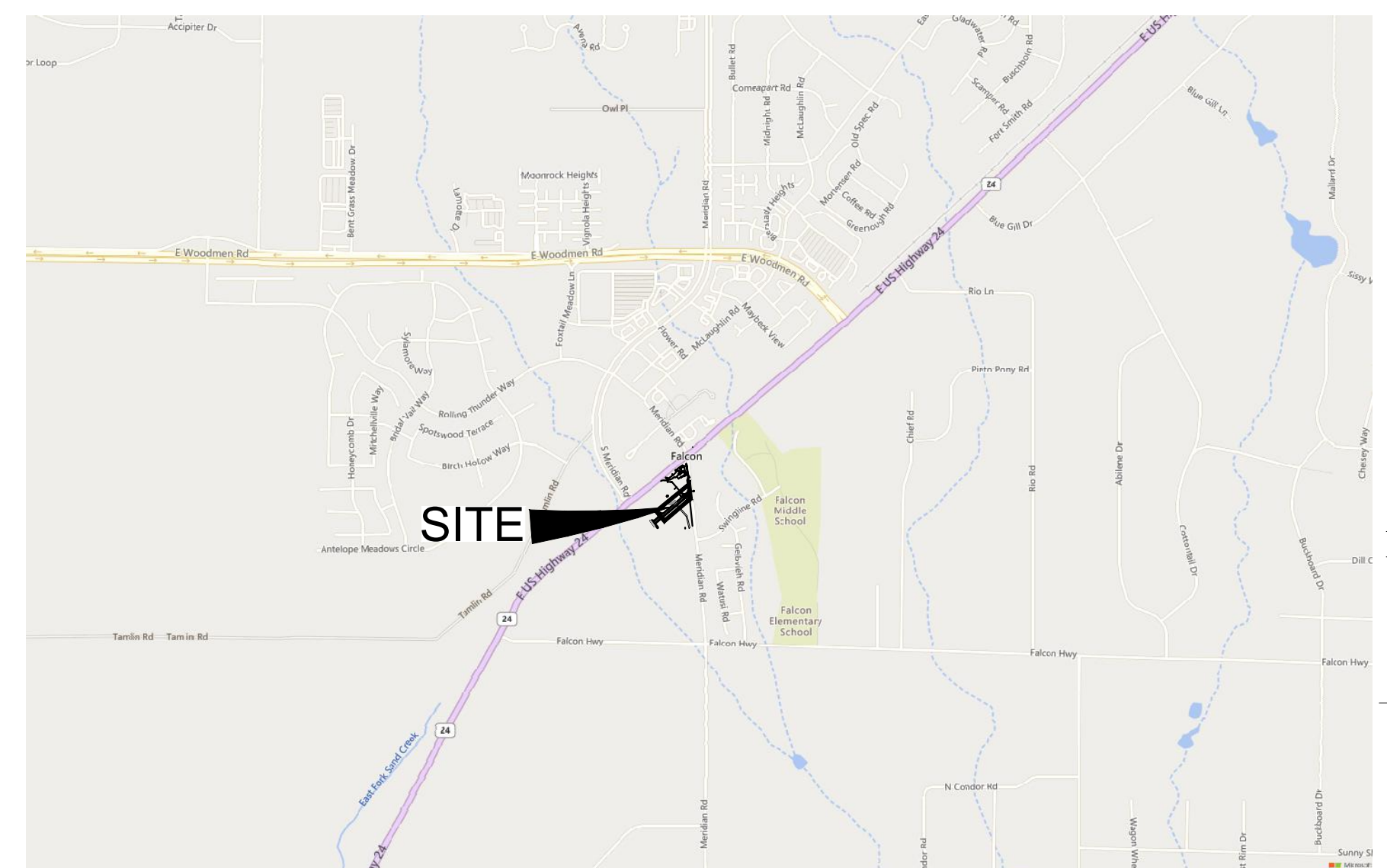

VICINITY MAP

1" = 2,000'

ENGINEER'S STATEMENT:

THESE DETAILED PLANS AND SPECIFICATIONS WERE PREPARED UNDER MY DIRECTION AND SUPERVISION. SAID PLANS AND SPECIFICATIONS HAVE BEEN PREPARED ACCORDING TO THE CRITERIA ESTABLISHED BY THE COUNTY FOR DETAILED ROADWAY, DRAINAGE, GRADING AND EROSION CONTROL PLANS AND SPECIFICATIONS, AND SAID PLANS AND SPECIFICATIONS ARE IN CONFORMITY WITH APPLICABLE MASTER DRAINAGE PLANS AND MASTER TRANSPORTATION PLANS. SAID PLANS AND SPECIFICATIONS MEET THE PURPOSES FOR WHICH THE PARTICULAR ROADWAY AND DRAINAGE FACILITIES ARE DESIGNED AND ARE CORRECT TO THE BEST OF MY KNOWLEDGE AND BELIEF. I ACCEPT RESPONSIBILITY FOR ANY LIABILITY CAUSED BY ANY NEGLIGENT ACTS, ERRORS OR OMISSIONS ON MY PART IN PREPARATION OF THESE DETAILED PLANS AND SPECIFICATIONS.

By: _____ Date: _____

NICOLE SCHANEL, PE #52434
FOR AND ON BEHALF OF MATRIX DESIGN GROUP, INC.

EL PASO COUNTY:

COUNTY PLAN REVIEW IS PROVIDED ONLY FOR GENERAL CONFORMANCE WITH COUNTY DESIGN CRITERIA. THE COUNTY IS NOT RESPONSIBLE FOR THE ACCURACY AND ADEQUACY OF THE DESIGN, DIMENSIONS, AND/OR ELEVATIONS WHICH SHALL BE CONFIRMED AT THE JOB SITE. THE COUNTY THROUGH THE APPROVAL OF THIS DOCUMENT ASSUMES NO RESPONSIBILITY FOR COMPLETENESS AND/OR ACCURACY OF THIS DOCUMENT.

FILED IN ACCORDANCE WITH THE REQUIREMENTS OF THE EL PASO COUNTY LAND DEVELOPMENT CODE, DRAINAGE CRITERIA MANUAL, VOLUMES 1 AND 2, AND ENGINEERING CRITERIA MANUAL AS AMENDED.

IN ACCORDANCE WITH ECM SECTION 1.12, THESE CONSTRUCTION DOCUMENTS WILL BE VALID FOR CONSTRUCTION FOR A PERIOD OF 2 YEARS FROM THE DATE SIGNED BY THE EL PASO COUNTY ENGINEER. IF CONSTRUCTION HAS NOT STARTED WITHIN THOSE 2 YEARS, THE PLANS WILL NEED TO BE RESUBMITTED FOR APPROVAL, INCLUDING PAYMENT OF REVIEW FEES AT THE PLANNING AND COMMUNITY DEVELOPMENT DIRECTORS DISCRETION.

JOSHUA PALMER _____ DATE _____
COUNTY ENGINEER / ECM ADMINISTRATOR

OWNER/DEVELOPER:

I, THE OWNER/DEVELOPER HAVE READ AND WILL COMPLY WITH THE REQUIREMENTS OF THE GRADING AND EROSION CONTROL PLAN AND ALL OF THE REQUIREMENTS SPECIFIED IN THESE DETAILED PLANS AND SPECIFICATIONS.

SOFA HERNANDEZ _____ DATE _____
LAND DEVELOPEMENT CONSULTANTS
950 S. CHERRY STREET, SUITE 512
DENVER, CO 80246

GENERAL CONSTRUCTION NOTES:

- STORMWATER DISCHARGES FROM CONSTRUCTION SITES SHALL NOT CAUSE OR THREATEN TO CAUSE POLLUTION, CONTAMINATION, OR DEGRADATION OF STATE WATERS. ALL WORK AND EARTH DISTURBANCE SHALL BE DONE IN A MANNER THAT MINIMIZES POLLUTION OF ANY ON-SITE OR OFF-SITE WATERS, INCLUDING WETLANDS.
- NOTWITHSTANDING ANYTHING DEPICTED IN THESE PLANS IN WORDS OR GRAPHIC REPRESENTATION, ALL DESIGN AND CONSTRUCTION RELATED TO ROADS, STORM DRAINAGE AND EROSION CONTROL SHALL CONFORM TO THE STANDARDS AND REQUIREMENTS OF THE MOST RECENT VERSION OF THE RELEVANT ADOPTED EL PASO COUNTY STANDARDS, INCLUDING THE LAND DEVELOPMENT CODE, THE ENGINEERING CRITERIA MANUAL, THE DRAINAGE CRITERIA MANUAL, AND THE DRAINAGE CRITERIA MANUAL VOLUME 2. ANY DEVIATIONS FROM REGULATIONS AND STANDARDS MUST BE REQUESTED, AND APPROVED, IN WRITING.
- A SEPARATE STORMWATER MANAGEMENT PLAN (SMWP) FOR THIS PROJECT SHALL BE COMPLETED AND AN EROSION AND STORMWATER QUALITY CONTROL PERMIT (ESQCP) ISSUED PRIOR TO COMMENCING CONSTRUCTION. DURING CONSTRUCTION THE SWMP IS THE RESPONSIBILITY OF THE DESIGNATED QUALIFIED STORMWATER MANAGER OR CERTIFIED EROSION CONTROL INSPECTOR. THE SWMP SHALL BE LOCATED ON SITE AT ALL TIMES DURING CONSTRUCTION AND SHALL BE KEPT UP TO DATE WITH WORK PROGRESS AND CHANGES IN THE FIELD.
- ONCE THE ESQCP IS APPROVED AND A "NOTICE TO PROCEED" HAS BEEN ISSUED, THE CONTRACTOR MAY INSTALL THE INITIAL STAGE EROSION AND SEDIMENT CONTROL MEASURES AS INDICATED ON THE APPROVED GEC. A PRECONSTRUCTION MEETING BETWEEN THE CONTRACTOR, ENGINEER, AND EL PASO COUNTY WILL BE HELD PRIOR TO ANY CONSTRUCTION. IT IS THE RESPONSIBILITY OF THE APPLICANT TO COORDINATE THE MEETING TIME AND PLACE WITH COUNTY STAFF.
- CONTROL MEASURES MUST BE INSTALLED PRIOR TO COMMENCEMENT OF ACTIVITIES THAT COULD CONTRIBUTE POLLUTANTS TO STORMWATER. TEMPORARY SEDIMENT AND EROSION CONTROL MEASURES FOR ALL SLOPES, CHANNELS, DITCHES, AND DISTURBED LAND AREAS SHALL BE INSTALLED IMMEDIATELY UPON COMPLETION OF THE DISTURBANCE.
- ALL TEMPORARY SEDIMENT AND EROSION CONTROL MEASURES SHALL BE MAINTAINED AND REMAIN IN EFFECTIVE OPERATING CONDITION UNTIL PERMANENT SOIL EROSION CONTROL MEASURES ARE IMPLEMENTED AND FINAL STABILIZATION IS ESTABLISHED. ALL PERSONS ENGAGED IN LAND DISTURBANCE ACTIVITIES SHALL ASSESS THE ADEQUACY OF CONTROL MEASURES AT THE SITE AND IDENTIFY IF CHANGES TO THOSE CONTROL MEASURES ARE NEEDED TO ENSURE THE CONTINUED EFFECTIVE PERFORMANCE OF THE CONTROL MEASURES. ALL CHANGES TO TEMPORARY SEDIMENT AND EROSION CONTROL MEASURES MUST BE INCORPORATED INTO THE STORMWATER MANAGEMENT PLAN PRIOR TO IMPLEMENTATION.
- TEMPORARY STABILIZATION SHALL BE IMPLEMENTED ON DISTURBED AREAS AND STOCKPILES WHERE GROUND DISTURBING CONSTRUCTION ACTIVITY HAS PERMANENTLY CEASED OR TEMPORARILY CEASED FOR LONGER THAN 14 DAYS. AN AREA THAT IS GOING TO REMAIN IN AN INTERIM STATE FOR MORE THAN 60 DAYS SHALL ALSO BE STABILIZED.
- FINAL STABILIZATION MUST BE IMPLEMENTED AT ALL APPLICABLE CONSTRUCTION SITES. FINAL STABILIZATION IS ACHIEVED WHEN ALL GROUND DISTURBING ACTIVITIES ARE COMPLETE AND ALL DISTURBED AREAS EITHER HAVE A UNIFORM VEGETATIVE COVER WITH INDIVIDUAL PLAN DENSITY OF 70 PERCENT OF PRE-DISTURBANCE LEVELS ESTABLISHED OR EQUIVALENT PERMANENT ALTERNATIVE STABILIZATION METHOD IS IMPLEMENTED. ALL TEMPORARY SEDIMENT AND EROSION CONTROL MEASURES SHALL BE REMOVED UPON FINAL STABILIZATION AND BEFORE PERMIT CLOSURE.
- ALL PERMANENT STORMWATER MANAGEMENT FACILITIES SHALL BE INSTALLED AS DEFINED IN THE APPROVED PLANS. ANY PROPOSED CHANGES THAT EFFECT THE HYDROLOGY OR HYDRAULICS OF A PERMANENT STORMWATER MANAGEMENT STRUCTURES MUST BE APPROVED BY THE ECM ADMINISTRATOR PRIOR TO IMPLEMENTATION.
- ANY EARTH DISTURBANCE SHALL BE CONDUCTED IN SUCH A MANNER SO AS TO EFFECTIVELY MINIMIZE ACCELERATED SOIL EROSION AND RESULTING SEDIMENTATION. ALL DISTURBANCES SHALL BE DESIGNED, CONSTRUCTED, AND COMPLETED SO THAT THE EXPOSED AREA OF ANY DISTURBED LAND SHALL BE LIMITED TO THE SHORTEST PRACTICAL PERIOD OF TIME. PRE-EXISTING VEGETATION SHALL BE PROTECTED AND MAINTAINED WITHIN 50 HORIZONTAL FEET OF A WATERS OF THE STATE, UNLESS INFEASIBLE.
- COMPACTION OF SOIL MUST BE PREVENTED IN AREAS DESIGNATED FOR INFILTRATION CONTROL MEASURES OR WHERE FINAL STABILIZATION WILL BE ACHIEVED BY VEGETATIVE COVER. AREAS DESIGNATED FOR INFILTRATION CONTROL SHALL ALSO BE PROTECTED FROM SEDIMENTATION DURING CONSTRUCTION UNTIL FINAL STABILIZATION IS ACHIEVED.
- ANY TEMPORARY OR PERMANENT FACILITY DESIGNED AND CONSTRUCTED FOR THE CONVEYANCE OF STORMWATER AROUND, THROUGH, OR FROM THE EARTH DISTURBANCE AREA SHALL BE A STABILIZED CONVEYANCE DESIGNED TO MINIMIZE EROSION AND THE DISCHARGE OF SEDIMENT OFF SITE.
- CONCRETE WASH WATER SHALL BE CONTAINED AND DISPOSED OF IN ACCORDANCE WITH THE SWMP. NO WASH WATER SHALL BE DISCHARGED TO OR ALLOWED TO RUNOFF TO STATE WATERS, INCLUDING ANY SURFACE OR SUBSURFACE STORM DRAINAGE SYSTEM OR FACILITIES. CONCRETE WASHOUT SHALL NOT BE LOCATED IN AN AREA WHERE SHALLOW GROUNDWATER MAY BE PRESENT, OR WITHIN 50 FEET OF A SURFACE WATER BODY.

- DURING DEWATERING OPERATIONS OF UNCONTAMINATED GROUND WATER MAY BE DISCHARGED ON SITE, BUT SHALL NOT LEAVE THE SITE IN THE FORM OF SURFACE RUNOFF UNLESS AN APPROVED STATE DEWATERING PERMIT IS IN PLACE.
- EROSION CONTROL BLANKETING OR OTHER PROTECTIVE COVERING SHALL BE USED ON SLOPES STEEPER THAN 3:1.
- BUILDING, CONSTRUCTION, EXCAVATION, OR OTHER WASTE MATERIALS SHALL NOT BE TEMPORARILY PLACED OR STORED IN THE STREET, ALLEY, OR OTHER PUBLIC WAY, UNLESS IN ACCORDANCE WITH AN APPROVED TRAFFIC CONTROL PLAN. BMP'S MAY BE REQUIRED BY EL PASO COUNTY ENGINEERING IF DEEMED NECESSARY, BASED ON SPECIFIC CONDITIONS AND CIRCUMSTANCES.
- VEHICLE TRACKING OF SOILS AND CONSTRUCTION DEBRIS OFF-SITE SHALL BE MINIMIZED. MATERIALS TRACKED OFFSITE SHALL BE CLEANED UP AND PROPERLY DISPOSED OF IMMEDIATELY.
- CONTRACTOR SHALL BE RESPONSIBLE FOR THE REMOVAL OF ALL WASTES FROM THE CONSTRUCTION SITE FOR DISPOSAL IN ACCORDANCE WITH LOCAL AND STATE REGULATORY REQUIREMENTS. NO CONSTRUCTION DEBRIS, TREE SLASH, BUILDING MATERIAL WASTES OR UNUSED BUILDING MATERIALS SHALL BE BURIED, DUMPED, OR DISCHARGED AT THE SITE.
- THE OWNER/DEVELOPER SHALL BE RESPONSIBLE FOR THE REMOVAL OF ALL CONSTRUCTION DEBRIS, DIRT, TRASH, ROCK, SEDIMENT, SOIL, AND SAND THAT MAY ACCUMULATE IN ROADS, STORM DRAINS AND OTHER DRAINAGE CONVEYANCE SYSTEMS AND STORMWATER APPURTENANCES AS A RESULT OF SITE DEVELOPMENT.
- THE QUANTITY OF MATERIALS STORED ON THE PROJECT SITE SHALL BE LIMITED, AS MUCH AS PRACTICAL, TO THAT QUANTITY REQUIRED TO PERFORM THE WORK IN AN ORDERLY SEQUENCE. ALL MATERIALS STORED ON-SITE SHALL BE STORED IN A NEAT, ORDERLY MANNER, IN THEIR ORIGINAL CONTAINERS, WITH ORIGINAL MANUFACTURER'S LABELS.
- NO CHEMICAL(S) HAVING THE POTENTIAL TO BE RELEASED IN STORMWATER ARE TO BE STORED OR USED ONSITE UNLESS PERMISSION FOR THE USE OF SUCH CHEMICAL(S) IS GRANTED IN WRITING BY THE ECM ADMINISTRATOR. IN GRANTING APPROVAL FOR THE USE OF SUCH CHEMICAL(S), SPECIAL CONDITIONS AND MONITORING MAY BE REQUIRED.
- BULK STORAGE OF ALLOWED PETROLEUM PRODUCTS OR OTHER ALLOWED LIQUID CHEMICALS IN EXCESS OF 55 GALLONS SHALL REQUIRE ADEQUATE SECONDARY CONTAINMENT PROTECTION TO CONTAIN ALL SPILLS ONSITE AND TO PREVENT ANY SPILLED MATERIALS FROM ENTERING STATE WATERS, ANY SURFACE OR SUBSURFACE STORM DRAINAGE SYSTEM OR OTHER FACILITIES.
- NO PERSON SHALL CAUSE THE IMPEDIMENT OF STORMWATER FLOW IN THE CURB AND GUTTER OR DITCH EXCEPT WITH APPROVED SEDIMENT CONTROL MEASURES.
- OWNER/DEVELOPER AND THEIR AGENTS SHALL COMPLY WITH THE "COLORADO WATER QUALITY CONTROL ACT" (TITLE 25, ARTICLE 8, CRS), AND THE "CLEAN WATER ACT" (33 USC 1344), IN ADDITION TO THE REQUIREMENTS OF THE LAND DEVELOPMENT CODE, DCM VOLUME II AND THE ECM APPENDIX I. ALL APPROPRIATE PERMITS MUST BE OBTAINED BY THE CONTRACTOR PRIOR TO CONSTRUCTION (1041, NPDES, FLOODPLAIN, 404, FUGITIVE DUST, ETC.). IN THE EVENT OF CONFLICTS BETWEEN THESE REQUIREMENTS AND OTHER LAWS, RULES, OR REGULATIONS OF OTHER FEDERAL, STATE, LOCAL, OR COUNTY AGENCIES, THE MOST RESTRICTIVE LAWS, RULES, OR REGULATIONS SHALL APPLY.
- ALL CONSTRUCTION TRAFFIC MUST ENTER/EXIT THE SITE ONLY AT APPROVED CONSTRUCTION ACCESS POINTS.
- PRIOR TO CONSTRUCTION THE PERMITTEE SHALL VERIFY THE LOCATION OF EXISTING UTILITIES.
- A WATER SOURCE SHALL BE AVAILABLE ON SITE DURING EARTHWORK OPERATIONS AND SHALL BE UTILIZED AS REQUIRED TO MINIMIZE DUST FROM EARTHWORK EQUIPMENT AND WIND.
- THE SOILS REPORT FOR THIS SITE HAS BEEN PREPARED BY TERRACON CONSULTANTS, INC., DATED NOVEMBER 30, 2018 AND SHALL BE CONSIDERED A PART OF THESE PLANS.
- AT LEAST TEN (10) DAYS PRIOR TO THE ANTICIPATED START OF CONSTRUCTION, FOR PROJECTS THAT WILL DISTURB ONE (1) ACRE OR MORE, THE OWNER OR OPERATOR OF CONSTRUCTION ACTIVITY SHALL SUBMIT A PERMIT APPLICATION FOR STORMWATER DISCHARGE TO THE COLORADO DEPARTMENT OF PUBLIC HEALTH AND ENVIRONMENT, WATER QUALITY DIVISION. THE APPLICATION CONTAINS CERTIFICATION OF COMPLETION OF A STORMWATER MANAGEMENT PLAN (SWMP), OF WHICH THIS GRADING AND EROSION CONTROL PLAN MAY BE A PART. FOR INFORMATION OR APPLICATION MATERIALS CONTACT:

COLORADO DEPARTMENT OF PUBLIC HEALTH AND ENVIRONMENT
WATER QUALITY CONTROL DIVISION
WQCD - PERMITS
4300 CHERRY CREEK DRIVE SOUTH
DENVER, CO 80246-1530
ATTN: PERMITS UNIT

NPDES NOTES:

- THE CONTRACTOR SHALL REMOVE ALL SEDIMENT, MUD, AND CONSTRUCTION DEBRIS THAT MAY ACCUMULATE IN THE FLOWLINES AND PUBLIC RIGHTS OF WAYS AS A RESULT OF THIS CONSTRUCTION PROJECT. SAID REMOVAL SHALL BE CONDUCTED IN A TIMELY MANNER, OR AS DIRECTED BY THE ENGINEER.
- THIS CONSTRUCTION ACTIVITIES STORMWATER MANAGEMENT PLAN (SWMP) HAS BEEN SUBMITTED AS PART OF AN APPLICATION FOR AN EROSION AND SEDIMENT CONTROL PERMIT FILED WITH THE CITY OF COLORADO SPRINGS AND AS INCLUSION BY REFERENCE TO THE CDPHE CONSTRUCTION ACTIVITY PERMIT. THE SWMP IS A LIVING DOCUMENT AND ADDITIONAL EROSION AND SEDIMENT CONTROL MEASURES MAY BE REQUIRED OF THE CONTRACTOR DUE TO UNFORESEEN EROSION PROBLEMS OR IF THE SUBMITTED PLAN DOES NOT FUNCTION AS INTENDED. THE REQUIREMENTS OF THIS PLAN SHALL BE THE OBLIGATION OF THE LAND OWNER AND/OR HIS SUCCESSORS OR HEIRS; UNTIL SUCH TIME AS THE PLAN IS PROPERLY COMPLETED, MODIFIED, OR VOIDED.
- THE CONTRACTOR SHALL BE HELD RESPONSIBLE FOR REMEDIATION OF ANY ADVERSE IMPACTS TO ADJACENT WATERWAYS, WETLANDS, ETC., RESULTING FROM WORK DONE AS PART OF THIS PROJECT.
- THE CONTRACTOR SHALL PREVENT SEDIMENT, DEBRIS AND ALL OTHER POLLUTANTS FROM ENTERING THE STORM SEWER SYSTEM DURING ALL DEMOLITION, EXCAVATION, TRENCHING, BORING, GRADING OR OTHER CONSTRUCTION OPERATIONS THAT ARE PART OF THIS PROJECT.
- A LAYER OF SUITABLE MULCH SHALL BE APPLIED TO ALL DISTURBED PORTIONS OF THE SITE WITHIN 21 DAYS OF THE COMPLETION OF GRADING. SAID MULCH SHALL BE APPLIED AT A RATE OF 2 TONS PER ACRE AND SHALL BE TACKED OR FASTENED BY AN APPROVED METHOD SUITABLE FOR THE TYPE OF MULCH USED. ROUGH-CUT STREETS SHALL BE MULCHED UNLESS A LAYER OF AGGREGATE ROAD BASE OR ASPHALT PAVING IS TO BE APPLIED TO SAID ROUGH-CUT STREETS WITHIN THE 21 DAY PERIOD AFTER COMPLETION OF OVERLOT GRADING. AN AREA THAT IS GOING TO REMAIN IN AN INTERIM STATE FOR MORE THEN SIXTY (60) DAYS SHALL ALSO BE SEEDED. ALL TEMPORARY SOIL EROSION CONTROL MEASURES AND BMP'S SHALL BE MAINTAINED UNTIL PERMANENT SOIL EROSION CONTROL MEASURES ARE IMPLEMENTED.
- THE CONTRACTOR SHALL LOCATE, INSTALL, AND MAINTAIN ALL EROSION CONTROL AND WATER QUALITY "BEST MANAGEMENT PRACTICES" AS INDICATED IN THE APPROVED CONSTRUCTION ACTIVITIES STORMWATER MANAGEMENT PLAN. BMP'S SHALL BE MAINTAINED AND KEPT IN GOOD REPAIR FOR THE DURATION OF THIS PROJECT.
- AT A MINIMUM, THE CONTRACTOR SHALL INSPECT, AND KEEP A LOG OF, ALL BMP'S WEEKLY AND AFTER SIGNIFICANT PRECIPITATION EVENTS. ALL NECESSARY MAINTENANCE AND REPAIR SHALL BE COMPLETED IN A TIMELY MANNER. ACCUMULATED SEDIMENT AND DEBRIS SHALL BE REMOVED FROM A BMP WHEN THE SEDIMENT LEVEL REACHES ONE-HALF THE HEIGHT OF THE BMP, OR, AT ANY TIME THAT SEDIMENT OR DEBRIS ADVERSELY IMPACTS THE FUNCTIONING OF THE BMP.
- THE CONTRACTOR SHALL PROPERLY COVER ALL LOADS OF CUT AND FILL MATERIAL IMPORTED TO OR EXPORTED FROM THIS SITE TO PREVENT LOSS OF THE MATERIAL DURING TRANSPORT WITHIN PUBLIC RIGHTS OF WAY.
- THE USE OF REBAR, STEEL STAKES, OR STEEL FENCE POSTS TO STAKE DOWN STRAW OR HAY BALES; OR TO SUPPORT SILT FENCING USED AS AN EROSION CONTROL MEASURE; IS PROHIBITED. THE USE OF OSHA APPROVED COLORED WARNING CAPS ON REBAR OR FENCE POSTS USED WITH EROSION CONTROL MEASURES IS NOT ACCEPTABLE.
- SOILS THAT WILL BE STOCKPILED FOR MORE THAN 30 DAYS SHALL BE MULCHED AND SEEDED WITH A TEMPORARY OR PERMANENT GRASS COVER WITHIN 21 DAYS OF STOCKPILE CONSTRUCTION. IF STOCKPILES ARE LOCATED WITHIN 100 FEET OF A DRAINAGEWAY, ADDITIONAL SEDIMENT CONTROLS SUCH AS TEMPORARY DIKES OR SILT FENCE SHALL BE REQUIRED.
- MODIFICATION OF AN ACTIVE EROSION AND SEDIMENT CONTROL PERMIT BY THE CONTRACTOR SHALL REQUIRE TIMELY NOTIFICATION OF AND APPROVAL BY THE CITY OF COLORADO SPRINGS. TERMINATION OF AN ACTIVE EROSION AND SEDIMENT CONTROL PERMIT UPON COMPLETION OF THE PROJECT REQUIRES NOTIFICATION OF AND APPROVAL BY THE CITY OF COLORADO SPRINGS.
- UNLESS CONFINED IN A PREDEFINED, BERMED CONTAINMENT AREA, THE CLEANING OF CONCRETE TRUCK DELIVERY CHUTES IS PROHIBITED AT THE JOB SITE. THE DISCHARGE OF WATER CONTAINING WASTE CEMENT TO THE STORM SEWER SYSTEM IS PROHIBITED.
- THE CONTRACTOR SHALL PROTECT ALL STORM SEWER FACILITIES ADJACENT TO ANY LOCATION WHERE PAVEMENT CUTTING OPERATIONS INVOLVING WHEEL CUTTING, SAW CUTTING OR ABRASIVE WATER JET CUTTING ARE TO TAKE PLACE. THE DISCHARGE OF ANY WATER CONTAMINATED BY WASTE PRODUCTS FROM CUTTING OPERATIONS TO THE STORM SEWER SYSTEM IS PROHIBITED. THE CONTRACTOR SHALL REMOVE AND PROPERLY DISPOSE OF ALL WASTE PRODUCTS GENERATED BY SAID CUTTING OPERATIONS ON A DAILY BASIS.
- LOCATION OF STAGING, STORAGE, EQUIPMENT MAINTENANCE, TEMPORARY DISPOSAL, VEHICLE TRACKING CONTROL AND CONCRETE TRUCK WASHOUT AREAS WILL BE DETERMINED IN THE FIELD AT THE START OF CONSTRUCTION ACTIVITY AND DELINEATED ON THIS PLAN.

NRCS SOIL SURVEY FOR EL PASO COUNTY

SOIL ID NO.	SOIL TYPE	HYDROLOGIC CLASSIFICATION
9	BLAKELAND-FLUVAQUENTIC HAPLAQUOLLS	A
19	COLUMBINE GRAVELLY SANDY LOAM (0%-3% SLOPES)	A

TIMING

ANTICIPATED STARTING AND COMPLETION TIME PERIOD OF SITE GRADING: JANUARY 2023 THRU AUGUST 2024

EXPECTED DATE ON WHICH THE FINAL STABILIZATION WILL BE COMPLETED: AUGUST 2024

AREAS

TOTAL AREA: 1.63 ACRES

RECEIVING WATERS

NAME OF RECEIVING WATERS
CHICO CREEK (ULTIMATE)

ENGINEER'S NOTES:

THE EXISTING VEGETATION CONSISTS OF NATIVE GRASSES AND SCRUB OAK WITH AREAS OF FARM TILLAGE.



Matrix
2435 RESEARCH PARKWAY, SUITE
300 COLORADO SPRINGS, CO 80920
PHONE: (719) 575-0100

LAND DEVELOPMENT
CONSULTANTS, LLC
950 S. CHERRY ST., SUITE 512
DENVER, CO 80246

OWNER/DEVELOPER:



ROCKY MOUNTAINS DIVISION
5500 S QUEBEC STREET, SUITE 100
GREENWOOD VILLAGE, CO 80111
PHONE: (720) 758-8223

SEAL

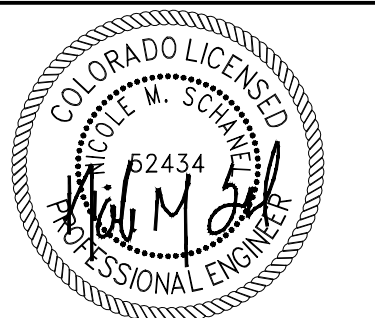

FOR AND ON BEHALF OF MATRIX DESIGN GROUP, INC
CONTRACTOR IS RESPONSIBLE FOR OBTAINING THE
MOST RECENT PROJECT CONSTRUCTION DOCUMENTS.
MATRIX DESIGN GROUP IS NOT RESPONSIBLE FOR
CHANGES, ALTERATIONS, OR USE OF CONSTRUCTION
DOCUMENTS PRIOR TO JURISDICTIONAL APPROVAL.

VICINITY MAP: NTS

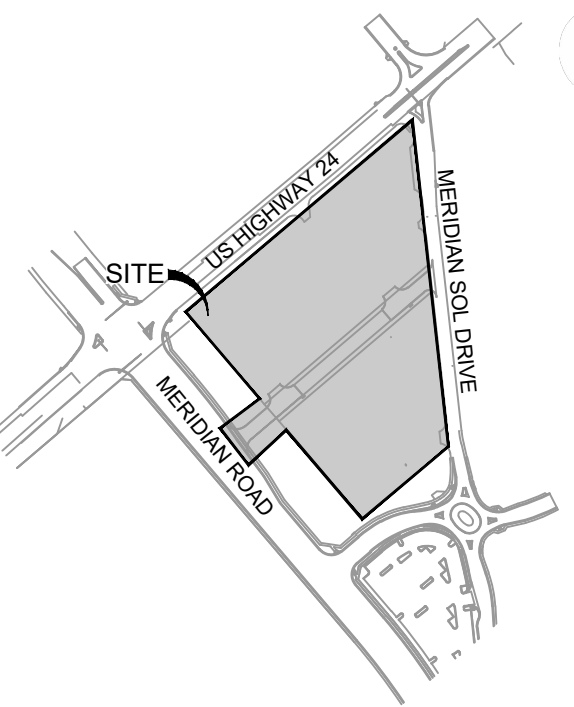

PROJECT:

CIRCLE K STORES INC.

FINAL PLAT OFFSITE CDS

CIRCLE K - US24 & MERIDIAN
FALCON, CO

REVISION HISTORY:

NO.	DATE	DESCRIPTION	BY

DRAWING INFORMATION:

PROJECT NO: 21.1207.037

DRAWN BY: RPD

CHECKED BY: NMS

DESIGNED BY: NMS

SHEET TITLE:

GENERAL NOTES

SHEET 2 OF 14
GN01

GENERAL NOTES:

- ALL WORK SHALL BE DONE IN ACCORDANCE WITH THE EL PASO COUNTY ENGINEERING CRITERIA MANUAL, REVISED 12-13-2016 AND CDOT STANDARD SPECIFICATIONS, LATEST REVISION.
- IT SHALL BE THE CONTRACTOR'S RESPONSIBILITY TO ENSURE THAT ALL WORK IS PERFORMED IN ACCORDANCE WITH APPLICABLE STANDARDS AND REGULATIONS AS SET FORTH BY THE OCCUPATIONAL SAFETY AND HEALTH ADMINISTRATION (O.S.H.A.).
- NO FIELD CHANGES SHALL BE MADE WITHOUT PRIOR WRITTEN APPROVAL OF THE FIELD ENGINEER.
- SUBMITTALS SHALL BE MADE FOR ALL MATERIALS TO BE INCORPORATED INTO THE PROJECT.
- UTILITY LINES AS SHOWN ON THE PLAN SHEETS ARE PLOTTED FROM THE BEST AVAILABLE INFORMATION. THE CONTRACTOR SHALL BE RESPONSIBLE FOR THE VERIFICATION AND PROTECTION OF ALL UTILITIES IN PLACE.
- THE CONTRACTOR SHALL CONTACT THE UTILITY NOTIFICATION CENTER OF COLORADO AT 1-800-922-1987 TWO BUSINESS DAYS IN ADVANCE OF ANY EXCAVATION OR GRADING.
- THE CONTRACTOR SHALL PROTECT AND MAINTAIN ALL UTILITY AND STRUCTURES AFFECTED BY THE WORK AND ANY DAMAGE SHALL BE REPAIRED AND RESTORED TO THE SATISFACTION OF THE RESPECTIVE UTILITY OWNER. THE CONTRACTOR IS RESPONSIBLE FOR THE LOCATION AND PROTECTION OF ALL UTILITIES DURING CONSTRUCTION. THE CONTRACTOR SHALL COORDINATE ALL UTILITY RELOCATIONS AS NECESSARY. THE COUNTY ENGINEERING INSPECTIONS, UTILITY DEPARTMENTS AND UTILITY OWNERS SHALL BE NOTIFIED A MINIMUM OF 48 HOURS PRIOR TO COMMENCING WORK WHERE THESE UTILITIES MAY BE AFFECTED.
- IN SOME OF THE PROPOSED AREAS OF CONSTRUCTION EXISTING UNDERGROUND TELEPHONE, FIBER AND CABLE TELEVISION FACILITIES MAY BE LOCATED IN CLOSE PROXIMITY TO THE WORK. THE CONTRACTOR MAY, IF NECESSARY, TEMPORARILY DISPLACE THE CABLES DURING CONSTRUCTION AND REINSTALL THEM IN ACCORDANCE WITH THE APPROPRIATE TELEPHONE, FIBER OR CABLE COMPANY'S GUIDELINES. COORDINATION WITH BOTH THE TELEPHONE AND CABLE TELEVISION COMPANY IS REQUIRED TO BE DONE BY THE CONTRACTOR.
- THE CONTRACTOR SHALL OBTAIN AN APPROVED TRAFFIC CONTROL PLAN PRIOR TO COMMENCING CONSTRUCTION ACTIVITIES.
- THE PHYSICAL FEATURES WITHIN THE LIMITS OF THE PROJECT HAVE BEEN SHOWN BASED ON THE BEST AVAILABLE INFORMATION AT THE TIME OF DESIGN. THE ENGINEER ASSUMES NO RESPONSIBILITY FOR THE ACCURACY OF THE FEATURES SHOWN. THE CONTRACTOR SHALL REVIEW AND VERIFY EXISTING PHYSICAL FEATURES AND ELEVATIONS THEMSELVES OF THE CONDITIONS TO BE ENCOUNTERED DURING THE CONSTRUCTION.
- THE CONTRACTOR SHALL LIMIT ALL WORK AND STORAGE AREAS TO THE PUBLIC RIGHT-OF-WAYS AND EASEMENTS. USE OF ANY PRIVATE AREAS FOR THIS PROJECT BY THE CONTRACTOR MUST BE APPROVED IN WRITING BY THE PROPERTY OWNER WITH A COPY OF THIS APPROVAL PROVIDED TO THE FIELD ENGINEER PRIOR TO USAGE.
- ALL CONSTRUCTION IS TO INCLUDE COMPACTION AND FINISH GRADING IN THE UNIT PRICE RELATED WORK ITEM.
- ALL WORK SHALL BE DONE TO THE LINES, GRADES, SECTIONS, AND ELEVATIONS SHOWN ON THE PLANS UNLESS OTHERWISE NOTED OR APPROVED BY THE FIELD ENGINEER.
- ALL MATERIALS AND WORKMANSHIP SHALL BE SUBJECT TO INSPECTION AND APPROVAL BY EL PASO COUNTY AND THE FIELD ENGINEER.
- THE FIELD ENGINEER SHALL BE NOTIFIED WITHIN 48 HOURS PRIOR TO THE COMMENCEMENT OF ANY CONSTRUCTION.
- PAYMENT, DIMENSIONS AND RADII ARE SHOWN TO THE FLOWLINE OF CURB UNLESS OTHERWISE NOTED.
- THE CONTRACTOR SHALL LIMIT CONSTRUCTION ACTIVITIES TO THOSE AREAS WITHIN THE LIMITS OF DISTURBANCE AND/OR TOES OF SLOPE AS SHOWN ON THE PLANS. ANY DISTURBANCE BEYOND THESE LIMITS SHALL BE RESTORED TO ORIGINAL CONDITIONS BY THE CONTRACTOR AT HIS/HER OWN EXPENSE.
- THE CONTRACTOR SHALL CLOSELY MONITOR ACCESS FOR HEAVY CONSTRUCTION EQUIPMENT THROUGH THE PROJECT AREAS.
- WHERE PAVEMENT IS TO ABUT EXISTING PAVEMENT, THE EXISTING PAVEMENT SHALL BE REMOVED TO A NEAT VERTICAL LINE BY FULL DEPTH SAWING. SAWING WILL NOT BE PAID FOR SEPARATELY BUT SHALL BE INCIDENTAL TO "REMOVAL OF ASPHALT PAVEMENT". THE CONTRACTOR WILL BE REQUIRED TO PAINT THE EDGE OF CUT PAVEMENT WITH DILUTED EMULSIFIED ASPHALT (SLOW SETTING) PRIOR TO PAVING OPERATIONS. VERTICAL EDGES SHALL NOT REMAIN OVERNIGHT. DILUTED EMULSIFIED ASPHALT FOR TACK COAT SHALL CONSIST OF ONE PART EMULSIFIED ASPHALT AND ONE PART WATER.
- WATER SHALL BE USED AS A DUST PALLIATIVE WHERE REQUIRED. LOCATIONS SHALL BE AS ORDERED. THE COST OF WATER SHALL BE INCIDENTAL TO OTHER BID ITEMS.
- THE PHYSICAL FEATURES REQUIRING REMOVAL OR OBLITERATION WITHIN THE PROJECT SHALL BECOME THE PROPERTY OF THE CONTRACTOR AND BE DISPOSED OF OFF-SITE.
- THE CONTRACTOR SHALL BE RESPONSIBLE FOR PRESERVING ANY MONUMENT, RANGE POINTS, TIES, BENCHMARKS AND/OR SURVEY CONTROL POINTS WHICH MAY BE DISTURBED OR DESTROYED BY CONSTRUCTION. SUCH POINTS SHALL BE REFERENCED AND REPLACED WITH APPROPRIATE MONUMENT BY A REGISTERED PROFESSIONAL LAND SURVEYOR AUTHORIZED TO PRACTICE LAND SURVEYING IN THE STATE OF COLORADO.

- THE CONTRACTOR SHALL HAVE A COPY OF ALL APPLICABLE STANDARDS AND PLANS ON SITE FOR THE DURATION OF THE PROJECT.
- THE CONTRACTOR SHALL NOT STOCKPILE MATERIAL WITHIN 10 FEET OF THE EDGE OF TRAVELED WAY.
- ANY LAYER OF BITUMINOUS PAVEMENT THAT IS TO HAVE SUCCEEDING LAYER PLACED THEREON SHALL BE COMPLETED FULL WIDTH BEFORE SUCCEEDING LAYER IS PLACED.
- BEFORE PLACEMENT OF THE TACK COAT, THE CONTRACTOR SHALL CLEAN THE PRESENT ROADWAY AS DIRECTED. CLEANING WILL NOT BE PAID FOR SEPARATELY, BUT SHALL BE INCLUDED IN THE COST OF THE PROJECT.
- A TACK COAT OF EMULSIFIED ASPHALT (SLOW SETTING) IS TO BE APPLIED BETWEEN PAVEMENT COURSES TO IMPROVE BOND. DILUTED EMULSIFIED ASPHALT FOR TACK COAT SHALL CONSIST OF 1 PART EMULSIFIED ASPHALT AND 1 PART WATER.
- THE CONTRACTOR SHALL FURNISH, INSTALL, AND MAINTAIN TEMPORARY TRAFFIC CONTROL DEVICES NECESSARY THROUGHOUT THE DURATION OF CONSTRUCTION. THE CONTRACTOR SHALL CONTACT TRAFFIC ENGINEERING FORTY-EIGHT (48) HOURS IN ADVANCE FOR ANY REQUIRED MODIFICATION OF TRAFFIC SIGNALS WITHIN CONSTRUCTION AREAS AS NECESSARY TO MAINTAIN SAFE OPERATIONS.
- ANY DISCREPANCY WITHIN THESE PLANS SHOULD BE BROUGHT TO THE IMMEDIATE ATTENTION OF THE ENGINEER AND WORK SHALL STOP UNTIL THE DISCREPANCY IS DISCUSSED AND DECISIONS/AGREEMENTS HAVE BEEN MADE.

EARTHWORK:

- THE CONTRACTOR SHALL BE RESPONSIBLE FOR THE LEGAL DISPOSAL OF ANY EXCESS SOIL, DEBRIS AND WASTE MATERIAL OFF OF THE PROJECT SITE.
- ANY MATERIAL NOT SUITABLE FOR BACKFILL SHALL BE REMOVED FROM THE SITE AND DISPOSED OF, BY AND AT THE EXPENSE OF THE CONTRACTOR.
- ANY SOIL LYING BELOW THE SUBGRADE ELEVATION WHICH IS DISTURBED BY CONSTRUCTION OPERATIONS SHALL BE REMOVED AND REPLACED WITH STRUCTURAL FILL IN ACCORDANCE WITH THE SPECIFICATION REQUIREMENTS.

BENCHMARK AND SURVEY CONTROL:

- THE CONTRACTOR SHALL BE RESPONSIBLE FOR CONSTRUCTION STAKING OF BOTH HORIZONTAL AND VERTICAL LAYOUT ON THIS PROJECT. COORDINATES ARE REFERENCED IN THE COORDINATE LIST SHOWN ON THESE PLANS. THE CONTRACTOR SHALL COORDINATE WITH THE PROJECT ENGINEER FOR INTERPRETATION AND INFORMATION IN STAKING OF THE PROJECT FOR CONSTRUCTION.
- PRIOR TO PROJECT COMPLETION, THE CONTRACTOR SHALL BE RESPONSIBLE FOR THE REPLACEMENT OF ANY PROPERTY MONUMENTATION DISTURBED OR REMOVED BY CONSTRUCTION OPERATIONS. THIS WORK SHALL BE PERFORMED BY A LAND SURVEYOR LICENSED IN THE STATE OF COLORADO. PROPERTY CORNERS WHICH FALL WITHIN NEW CONCRETE FLATWORK SHALL BE DURABLE AND SET FLUSH. THIS SHALL BE CONSIDERED INCIDENTAL TO THE PROJECT.

TRAFFIC GENERAL NOTES:

- THE CONTRACTOR SHALL PREPARE A DETAILED TRAFFIC CONTROL PLAN, SUBMIT TO EL PASO COUNTY DEPARTMENT OF PUBLIC WORKS FOR APPROVAL, AND OBTAIN APPROPRIATE PERMITS IN ACCORDANCE WITH THE M.U.T.C.D.
- THE CONTRACTOR SHALL BE RESPONSIBLE FOR ALL WORK ZONE TRAFFIC CONTROL, INCLUDING PEDESTRIAN DETOURS. CONTRACTOR SHALL BE RESPONSIBLE FOR FURNISHING, INSTALLING, AND MAINTAINING THE TEMPORARY TRAFFIC CONTROL DEVICES THROUGHOUT THE DURATION OF THE PROJECT.
- APPROVAL OF THESE PLANS BY THE COUNTY ENGINEER DOES NOT AUTHORIZE ANY WORK TO BE PERFORMED UNTIL A PERMIT HAS BEEN ISSUED.
- THE APPROVAL OF THESE PLANS OR ISSUANCE OF A PERMIT BY EL PASO COUNTY DOES NOT AUTHORIZE THE OWNER OR CONTRACTOR TO VIOLATE ANY FEDERAL, STATE OR CITY LAWS, ORDINANCES, REGULATIONS, OR POLICIES.
- ALL TRAFFIC SIGNS, PAVEMENT MARKINGS, AND TRAFFIC SIGNALS SHALL MEET OR EXCEED M.U.T.C.D. STANDARDS.
- THE CONTRACTOR SHALL NOT REMOVE ANY EXISTING SIGNS, PAVEMENT MARKINGS, OR TRAFFIC SIGNALS DURING THE PROJECT WITHOUT SIGNED AUTHORIZATION OF THE EL PASO COUNTY INSPECTOR ASSIGNED TO THE PROJECT.

STANDARD NOTES FOR EL PASO COUNTY CONSTRUCTION PLANS:

- ALL DRAINAGE AND ROADWAY CONSTRUCTION SHALL MEET THE STANDARDS AND SPECIFICATIONS OF THE EL PASO COUNTY DRAINAGE CRITERIA MANUAL, VOLUMES 1 AND 2, AND THE EL PASO COUNTY ENGINEERING CRITERIA MANUAL.
- CONTRACTOR SHALL BE RESPONSIBLE FOR THE NOTIFICATION AND FIELD NOTIFICATION OF ALL EXISTING UTILITIES, WHETHER SHOWN ON THE PLANS OR NOT, BEFORE BEGINNING CONSTRUCTION. LOCATION OF EXISTING UTILITIES SHALL BE VERIFIED BY THE CONTRACTOR PRIOR TO CONSTRUCTION. CALL 811 TO CONTACT THE UTILITY NOTIFICATION CENTER OF COLORADO (UNCC).

- CONTRACTOR SHALL KEEP A COPY OF THESE APPROVED PLANS, THE GRADING AND EROSION CONTROL PLAN, THE STORMWATER MANAGEMENT PLAN (SWMP), THE SOILS AND GEOTECHNICAL REPORT, AND THE APPROPRIATE DESIGN AND CONSTRUCTION STANDARDS AND SPECIFICATIONS AT THE JOB SITE AT ALL TIMES, INCLUDING THE FOLLOWING:
 - EL PASO COUNTY ENGINEERING CRITERIA MANUAL (ECM)
 - EL PASO COUNTY DRAINAGE CRITERIA MANUAL, VOLUMES 1 AND 2
 - COLORADO DEPARTMENT OF TRANSPORTATION (CDOT) STANDARD SPECIFICATIONS FOR ROAD AND BRIDGE CONSTRUCTION
 - CDOT M & S STANDARDS
- NOTWITHSTANDING ANYTHING DEPICTED IN THESE PLANS IN WORDS OR GRAPHIC REPRESENTATION, ALL DESIGN AND CONSTRUCTION RELATED TO ROADS, STORM DRAINAGE AND EROSION CONTROL SHALL CONFORM TO THE STANDARDS AND REQUIREMENTS OF THE MOST RECENT VERSION OF THE RELEVANT ADOPTED EL PASO COUNTY STANDARDS, INCLUDING THE LAND DEVELOPMENT CODE, THE ENGINEERING CRITERIA MANUAL, THE DRAINAGE CRITERIA MANUAL, AND THE DRAINAGE CRITERIA MANUAL VOLUME 2. ANY DEVIATIONS FROM REGULATIONS AND STANDARDS MUST BE REQUESTED, AND APPROVED, IN WRITING. ANY MODIFICATIONS NECESSARY TO MEET CRITERIA AFTER-THE-FACT WILL BE ENTIRELY THE DEVELOPER'S RESPONSIBILITY TO RECTIFY.
- IT IS THE DESIGN ENGINEER'S RESPONSIBILITY TO ACCURATELY SHOW EXISTING CONDITIONS, BOTH ONSITE AND OFFSITE, ON THE CONSTRUCTION PLANS. ANY MODIFICATIONS NECESSARY DUE TO CONFLICTS, OMISSIONS, OR CHANGED CONDITIONS WILL BE ENTIRELY THE DEVELOPER'S RESPONSIBILITY TO RECTIFY.
- CONTRACTOR SHALL SCHEDULE A PRE-CONSTRUCTION MEETING WITH EL PASO COUNTY PLANNING AND COMMUNITY DEVELOPMENT (PCD) - INSPECTIONS, PRIOR TO STARTING CONSTRUCTION.
- IT IS THE CONTRACTOR'S RESPONSIBILITY TO UNDERSTAND THE REQUIREMENTS OF ALL JURISDICTIONAL AGENCIES AND TO OBTAIN ALL REQUIRED PERMITS, INCLUDING BUT NOT LIMITED TO EL PASO COUNTY EROSION AND STORMWATER QUALITY CONTROL PERMIT (ESQCP), REGIONAL BUILDING FLOODPLAIN DEVELOPMENT PERMIT, U.S. ARMY CORPS OF ENGINEERS-ISSUED 401 AND/OR 404 PERMITS, AND COUNTY AND STATE FUGITIVE DUST PERMITS.
- CONTRACTOR SHALL NOT DEVIATE FROM THE PLANS WITHOUT FIRST OBTAINING WRITTEN APPROVAL FROM THE DESIGN ENGINEER AND PCD. CONTRACTOR SHALL NOTIFY THE DESIGN ENGINEER IMMEDIATELY UPON DISCOVERY OF ANY ERRORS OR INCONSISTENCIES.
- ALL STORM DRAIN PIPE SHALL BE CLASS III RCP UNLESS OTHERWISE NOTED AND APPROVED BY PCD.
- CONTRACTOR SHALL COORDINATE GEOTECHNICAL TESTING PER ECM STANDARDS. PAVEMENT DESIGN SHALL BE APPROVED BY EL PASO COUNTY PCD PRIOR TO PLACEMENT OF CURB AND GUTTER AND PAVEMENT.
- ALL CONSTRUCTION TRAFFIC MUST ENTER/EXIT THE SITE AT APPROVED CONSTRUCTION ACCESS POINTS.
- SIGHT VISIBILITY TRIANGLES AS IDENTIFIED IN THE PLANS SHALL BE PROVIDED AT ALL INTERSECTIONS. OBSTRUCTIONS GREATER THAN 18 INCHES ABOVE FLOWLINE ARE NOT ALLOWED WITHIN SIGHT TRIANGLES.
- SIGNING AND STRIPING SHALL COMPLY WITH EL PASO COUNTY DOT AND MUTCD CRITERIA. [IF APPLICABLE, ADDITIONAL SIGNING AND STRIPING NOTES WILL BE PROVIDED.]
- CONTRACTOR SHALL OBTAIN ANY PERMITS REQUIRED BY EL PASO COUNTY DOT, INCLUDING WORK WITHIN THE RIGHT-OF-WAY AND SPECIAL TRANSPORT PERMITS.
- THE LIMITS OF CONSTRUCTION SHALL REMAIN WITHIN THE PROPERTY LINE UNLESS OTHERWISE NOTED. THE OWNER/DEVELOPER SHALL OBTAIN WRITTEN PERMISSION AND EASEMENTS, WHERE REQUIRED, FROM ADJOINING PROPERTY OWNER(S) PRIOR TO ANY OFF-SITE DISTURBANCE, GRADING, OR CONSTRUCTION.

SIGNING & STRIPING NOTES:

- ALL SIGNS AND PAVEMENT MARKINGS SHALL BE IN COMPLIANCE WITH THE CURRENT MANUAL ON UNIFORM TRAFFIC CONTROL DEVICES (MUTCD).
- REMOVAL OF EXISTING PAVEMENT MARKINGS SHALL BE ACCOMPLISHED BY A METHOD THAT DOES NOT MATERIALLY DAMAGE THE PAVEMENT. THE PAVEMENT MARKINGS SHALL BE REMOVED TO THE EXTENT THAT THEY WILL NOT BE VISIBLE UNDER DAY OR NIGHT CONDITIONS. AT NO TIME WILL IT BE ACCEPTABLE TO PAINT OVER EXISTING PAVEMENT MARKINGS.
- ANY DEVIATION FROM THE STRIPING AND SIGNING PLAN SHALL BE APPROVED BY EL PASO COUNTY PLANNING AND COMMUNITY DEVELOPMENT.
- ALL SIGNS SHOWN ON THE SIGNING AND STRIPING PLAN SHALL BE NEW SIGNS. EXISTING SIGNS MAY REMAIN OR BE REUSED IF THEY MEET CURRENT EL PASO COUNTY AND MUTCD STANDARDS.
- STREET NAME AND REGULATORY STOP SIGNS SHALL BE ON THE SAME POST AT INTERSECTIONS.
- ALL REMOVED SIGNS SHALL BE DISPOSED OF IN A PROPER MANNER BY THE CONTRACTOR.
- ALL STREET NAME SIGNS SHALL HAVE "D" SERIES LETTERS, WITH LOCAL ROADWAY SIGNS BEING 4" UPPER-LOWER CASE LETTERING ON 8" BLANK AND NON-LOCAL ROADWAY SIGNS BEING 6" LETTERING, UPPER-LOWER CASE ON 12" BLANK, WITH A WHITE BORDER THAT IS NOT RECESSED. MULTI-LANE ROADWAYS WITH SPEED LIMITS OF 35 MPH OR HIGHER SHALL HAVE 8" UPPER-LOWER CASE LETTERING ON 12" BLANK WITH A WHITE BORDER THAT IS NOT RECESSED. THE WIDTH OF THE NON-RECESSED WHITE BORDERS SHALL MATCH PAGE 255 OF THE 2012 MUTCD "STANDARD HIGHWAY SIGNS". SIGNAL POLE MOUNTED AND OVERHEAD STREET SIGNS SHALL BE PER MUTCD SIZE STANDARDS.

- ALL TRAFFIC SIGNS SHALL HAVE A MINIMUM HIGH INTENSITY PRISMATIC GRADE SHEETING.
- ALL LOCAL RESIDENTIAL STREET SIGNS SHALL BE MOUNTED ON A 1.75" X 1.75" SQUARE TUBE SIGN POST AND STUB POST BASE. FOR OTHER APPLICATIONS, REFER TO THE CDOT STANDARD S-614-8 REGARDING USE OF THE P2 TUBULAR STEEL POST SLIPBASE DESIGN.
- ALL SIGNS SHALL BE SINGLE SHEET ALUMINUM WITH 0.100" MINIMUM THICKNESS.
- ALL LIMIT LINES/STOP LINES, CROSSWALK LINES, PAVEMENT LEGENDS, AND ARROWS SHALL BE A MINIMUM 125 MIL THICKNESS PREFORMED THERMOPLASTIC PAVEMENT MARKINGS WITH TAPERED LEADING EDGES PER CDOT STANDARD S-627-1. WORD AND SYMBOL MARKINGS SHALL BE THE NARROW TYPE. STOP BARS SHALL BE 24" IN WIDTH. CROSSWALKS LINES SHALL BE 12" WIDE AND 8' LONG PER CDOT S-627-1.
- ALL LONGITUDINAL LINES SHALL BE A MINIMUM 15MIL THICKNESS EPOXY PAINT. ALL NON-LOCAL RESIDENTIAL ROADWAYS SHALL INCLUDE BOTH RIGHT AND LEFT EDGE LINE STRIPING AND ANY ADDITIONAL STRIPING AS REQUIRED BY CDOT S-627-1.
- THE CONTRACTOR SHALL NOTIFY EL PASO COUNTY PLANNING AND COMMUNITY DEVELOPMENT (719) 520-6819 PRIOR TO AND UPON COMPLETION OF SIGNING AND STRIPING.
- THE CONTRACTOR SHALL OBTAIN A WORK IN THE RIGHT OF WAY PERMIT FROM THE EL PASO COUNTY DEPARTMENT OF PUBLIC WORKS (DPW) PRIOR TO ANY SIGNAGE OR STRIPING WORK WITHIN AN EXISTING EL PASO COUNTY ROADWAY.



Matrix
 2435 RESEARCH PARKWAY, SUITE
 300 COLORADO SPRINGS, CO 80920
 PHONE: (719) 575-0100

LAND DEVELOPMENT
 CONSULTANTS, LLC
 950 S. CHERRY ST., SUITE 512
 DENVER, CO 80246

CIRCLE K
 ROCKY MOUNTAINS DIVISION
 5500 S QUEBEC STREET, SUITE 100
 GREENWOOD VILLAGE, CO 80111
 PHONE: (720) 758-6223

SEAL

 FOR AND ON BEHALF OF MATRIX DESIGN GROUP, INC
 CONTRACTOR IS RESPONSIBLE FOR OBTAINING THE
 MOST RECENT PROJECT CONSTRUCTION DOCUMENTS.
 MATRIX DESIGN GROUP IS NOT RESPONSIBLE FOR
 CHANGES, ALTERATIONS, OR USE OF CONSTRUCTION
 DOCUMENTS PRIOR TO JURISDICTIONAL APPROVAL.

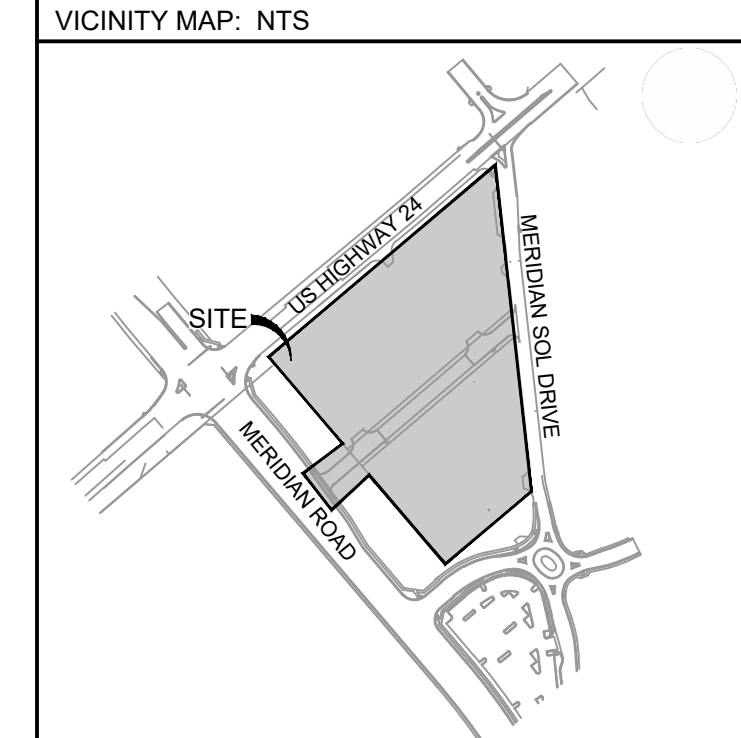

PROJECT:
CIRCLE K STORES INC.
 FINAL PLAT OFFSITE CDS
 CIRCLE K - US24 & MERIDIAN
 FALCON, CO

REVISION HISTORY:

NO.	DATE	DESCRIPTION	BY

DRAWING INFORMATION:
 PROJECT NO: 21.1207.037
 DRAWN BY: RPD
 CHECKED BY: NMS
 DESIGNED BY: NMS

GENERAL NOTES

SHEET 3 OF 14
GN02

FILE LOCATION: S:\CIRCLE K\HWY 24 & MERIDIAN\DWG\PLAN SETS\OFF-SITE CDS\GN02.DWG

ABBREVIATIONS

AD ALGEBRAIC DIFFERENCE	NC NORMAL CROWN
ASSY ASSEMBLY	NIC NOT IN CONTRACT
ASTM AMERICAN SOCIETY OF TESTING AND MATERIALS	NO NUMBER
APPROX APPROXIMATE or APPROXIMATELY	NOM NOMINAL
AVE AVENUE	NTS NOT TO SCALE
AVG AVERAGE	
B/C BACK OF CURB	OC ON CENTER
BL BASELINE	O/S OFFSET
BLVD BOULEVARD	
BTM BOTTOM	P PROPOSED
	PC POINT OF CURVATURE
CI CAST IRON	PCC POINT OF COMPOUND CURVE
CEN CENTER	PCR POINT OF CURB RETURN
CL CENTERLINE	PE PLAIN END
CFS CUBIC FEET PER SECOND	PIE PUBLIC IMPROVEMENT EASEMENT
CLR CLEAR	PGL PROFILE GRADE LINE
CMP CORRUGATED METAL PIPE	PL PROPERTY LINE
CONC CONCRETE	PRC POINT OF REVERSE CURVE
CONST CONSTRUCTION	PT POINT OF TANGENCY
CONT CONTINUOUS	PVC POINT OF VERTICAL CURVE or POLYVINYL CHLORIDE
	PVI POINT OF VERTICAL INTERSECTION
DIA DIAMETER	PVMT PAVEMENT
DN DOWN	PVT POINT OF VERTICAL TANGENT
DWG DRAWING	
	R OR RAD RADIUS
EA EACH	RC REVERSE CROWN
EGL ENERGY GRADE LINE	RCP REINFORCED CONCRETE PIPE
ELEV or EL ELEVATION	RED REDUCER
ELL ELBOW	REF REFERENCE
ESMT EASEMENT	REINF REINFORCING
EW EACHWAY	REQ REQUIRED
EX or EXIST EXISTING	REV REVISION
	ROW RIGHT-OF-WAY
	RT RIGHT
FES FLARED END SECTION	SCH SCHEDULE
FIN FINISHED	SD STORM SEWER
FL or FL FLOWLINE	SQ SQUARE
FLG FLANGE	ST STREET
FT FOOT / FEET	STA STATION
FRP FIBERGLASS REINFORCED PIPE	STD STANDARD
	STL STEEL
GAL GALLON	SS OR SAN SANITARY SEWER
GALV GALVANIZED	SW OR S/W SIDEWALK
GAU GAUGE (MATERIAL)	
GV GATE VALVE	TAN TANGENT
GW GROUNDWATER	TB THRUST BLOCK
	TBC TOP BACK OF CURB
HBP HOT BITUMINOUS PAVEMENT	TFC TOP FACE OF CURB
HERCP HORIZONTAL ELLIPTICAL REINFORCED CONCRETE PIPE	THD THREADED
HGL HYDRAULIC GRADE LINE	THK THICKNESS
HP HIGH POINT	TYP TYPICAL
HORIZ HORIZONTAL	
HCL HORIZONTAL CONTROL LINE	UG UNDERGROUND
HR HOUR	UTIL UTILITY
	VC VERTICAL CURVE
INV INVERT	VERT VERTICAL
	W WIDTH
K VERTICAL CURVE FACTOR	W/ WITH
LBS POUNDS	
LF LINEAR FEET	
LN LANE	
LP LOW POINT	
LS LANDSCAPING	
LT LEFT	
MAX MAXIMUM	
MFGR MANUFACTURER	
MH MANHOLE	
MID MIDDLE or MIDPOINT	
MIN MINIMUM	
MJ MECHANICAL JOINT	
MSL MEAN SEA LEVEL	

SYMBOLS

	PROPOSED CENTERLINE
	EXISTING FENCE
	RIGHT OF WAY/PROPERTY BOUNDARY
	EXISTING EASEMENT
	PROPERTY LINE/TRACT A BOUNDARY
	EXISTING CURB & GUTTER
	PROPOSED CURB & GUTTER
	EXISTING CONTOUR
	PROPOSED CONTOUR
	EXISTING UNDERGROUND UTILITY
	EXISTING UNDERGROUND UTILITY
	EXISTING UNDERGROUND UTILITY
	EXISTING WATER
	EXISTING HYDRANT
	EXISTING WATER VALVE
	EXISTING SANITARY
	PROPOSED STORM
	PROPOSED STORM FLARED END SECTION (FES)
	PROPOSED STORM INLET

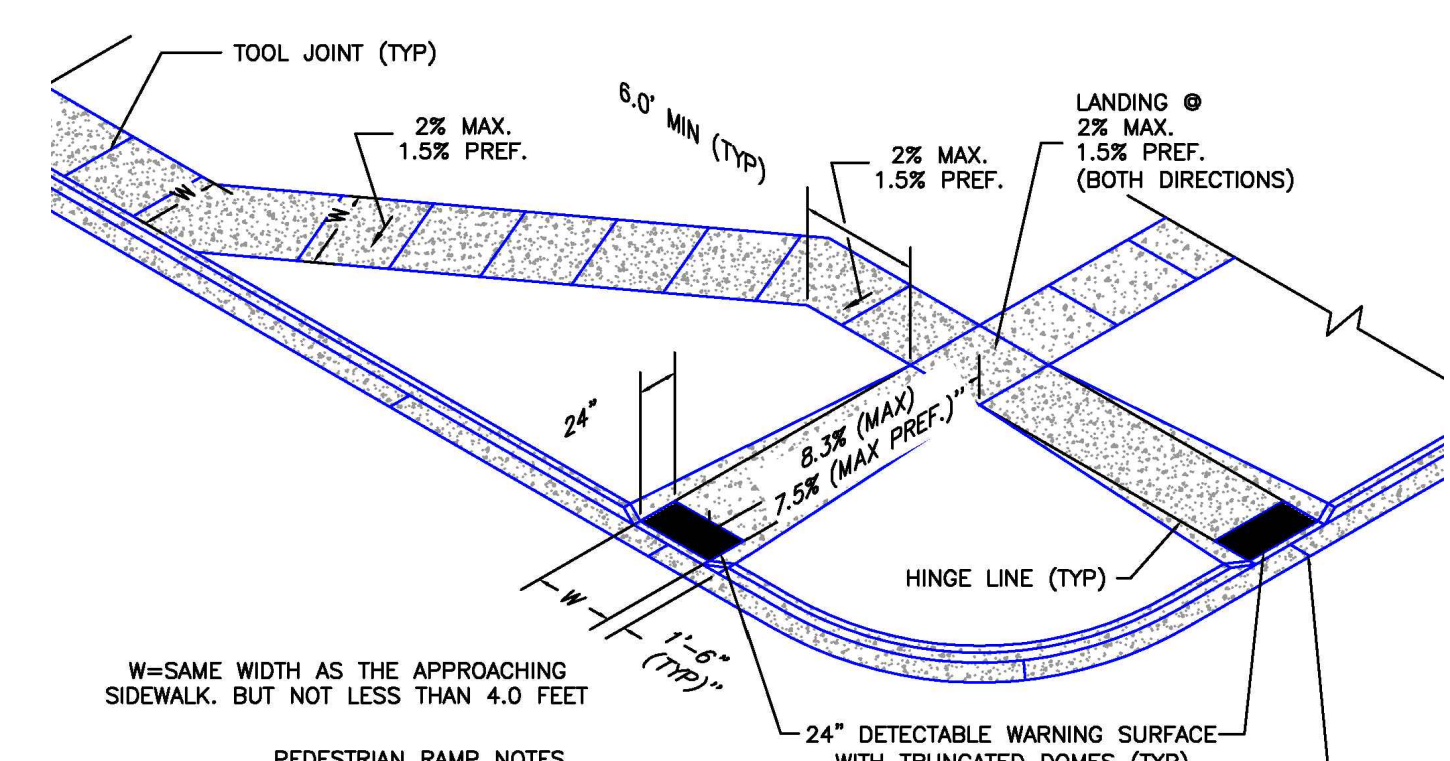
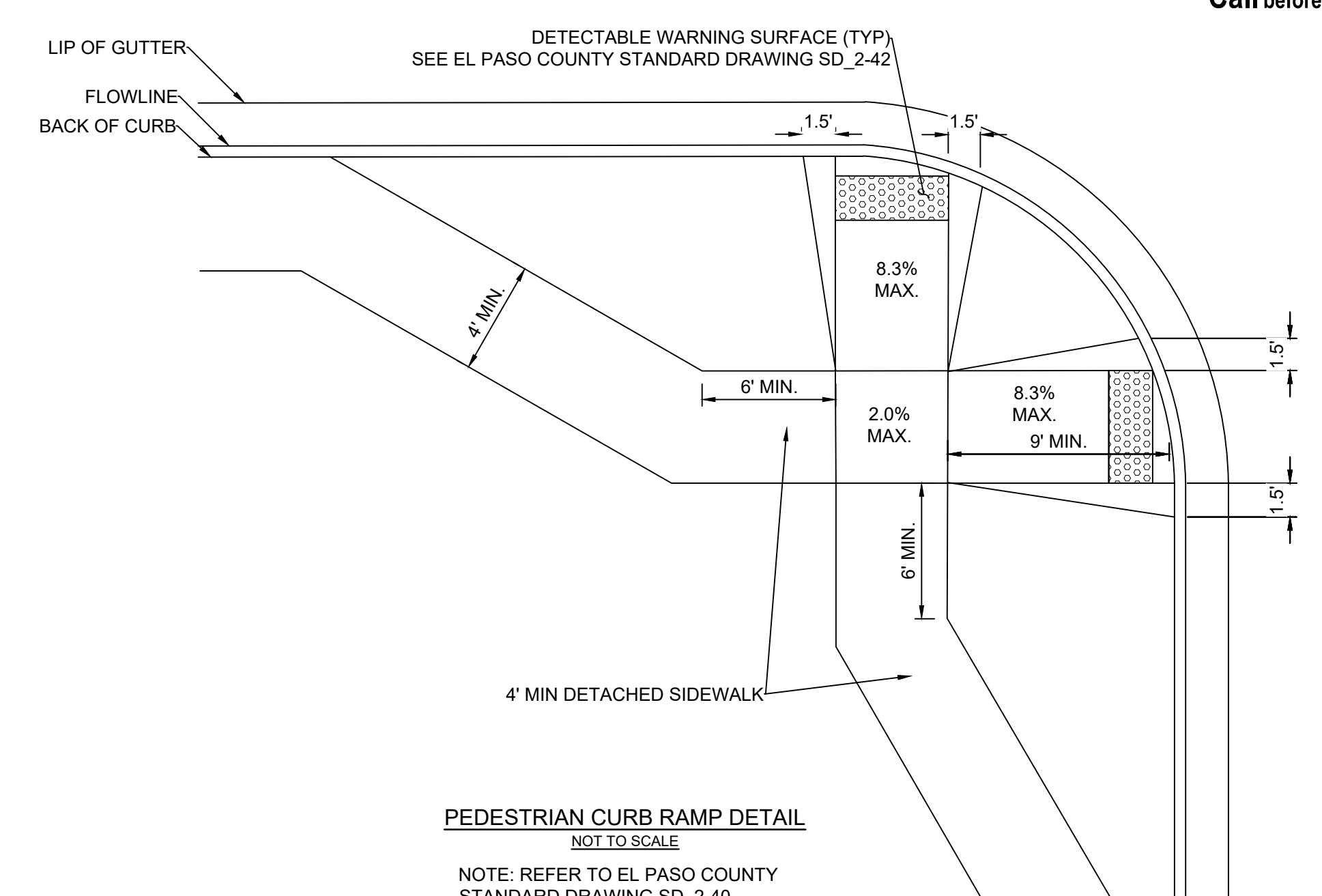

- ALL WORK SHALL BE DONE IN ACCORDANCE WITH THE CURRENT ENGINEERING CRITERIA MANUAL AND ADA REQUIREMENTS.
- CONTRACTOR TO NOTIFY ENGINEERING DIVISION INSPECTION STAFF 48 HOURS PRIOR TO CONCRETE PLACEMENT.
- PEDESTRIAN CURB RAMP CONSTRUCTION SHALL BE A MINIMUM 4,500 PSI CONCRETE, MINIMUM 4" THICK, NON-COLORED, NON-SCORED, COARSE BROOM FINISH.
- PEDESTRIAN CURB RAMP LOCATION AND LENGTH MAY REQUIRE MODIFICATION TO MAINTAIN THE 8.3% MAXIMUM RUNNING RAMP SLOPE DUE TO STREET INTERSECTION GRADES AND/OR ALIGNMENTS. SEE EGM SECTION 8.3.6 FOR PEDESTRIAN PUSHBUTTON LOCATION REQUIREMENTS.
- DETECTABLE WARNING SURFACE SHALL START A MINIMUM OF 6" BUT NOT MORE THAN 8" FROM THE FLOWLINE OF THE CURB AT ANY POINT.
- DETECTABLE WARNING SURFACE SHALL BE PREFABRICATED, CAST IRON (PATINA NATURAL FINISH) AND IN ACCORDANCE WITH EGM CHAPTER 6 AND SD_2-42. THERMOPLASTIC TRUNCATED DOMES AND PAVERS WILL NOT BE ACCEPTED.
- THE DETECTABLE WARNING SURFACE SHALL BE 24" IN LENGTH AND THE FULL WIDTH OF THE RAMP.
- PEDESTRIAN CURB RAMP WIDTH REQUIRED IS SAME AS APPROACHING SIDEWALK; 4" MINIMUM.
- ALL PEDESTRIAN CURB RAMP SHALL BE PERPENDICULAR TO TRAFFIC WITH THE EXCEPTION OF MID-BLOCK OR TERMINAL RAMP WHICH MAY BE PARALLEL, SUBJECT TO APPROVAL.
- DRAINAGE STRUCTURES, TRAFFIC SIGNAL/SIGNAGE, UTILITIES/JUNCTION BOXES, OR OTHER OBSTRUCTIONS WITHIN PROPOSED PEDESTRIAN CURB RAMP AREAS AND LANDINGS ARE PROHIBITED.
- THE COUNTER SLOPE OF THE GUTTER OR ROAD AT THE FOOT OF A RAMP SHALL NOT EXCEED 3%.

- GENERAL NOTES**
- WHERE THE 1'-4" FLARED SIDING OF A PERPENDICULAR CURB RAMP IS (ARE) CONTIGUOUS WITH A PEDESTRIAN OR HAND SURFACE AREA (PEDESTRIAN CIRCULATION PATH), THE MAXIMUM FLARE SLOPE SHALL NOT EXCEED 15:1.
 - PEDESTRIAN WALKWAY (PEDESTRIAN ACCESS ROUTE) AND/OR LOCATION OF EXISTING OR FUTURE PEDESTRIAN RAMP ON OPPOSITE CORNERS SHALL BE REVIEWED BEFORE CONSTRUCTING NEW RAMP.
 - AT MARKED PEDESTRIAN CROSSINGS, THE BOTTOM OF THE RAMPS, EXCLUSIVE OF THE FLARE SIDING, SHALL BE TOTALLY CONTAINED WITHIN THE MARKINGS.

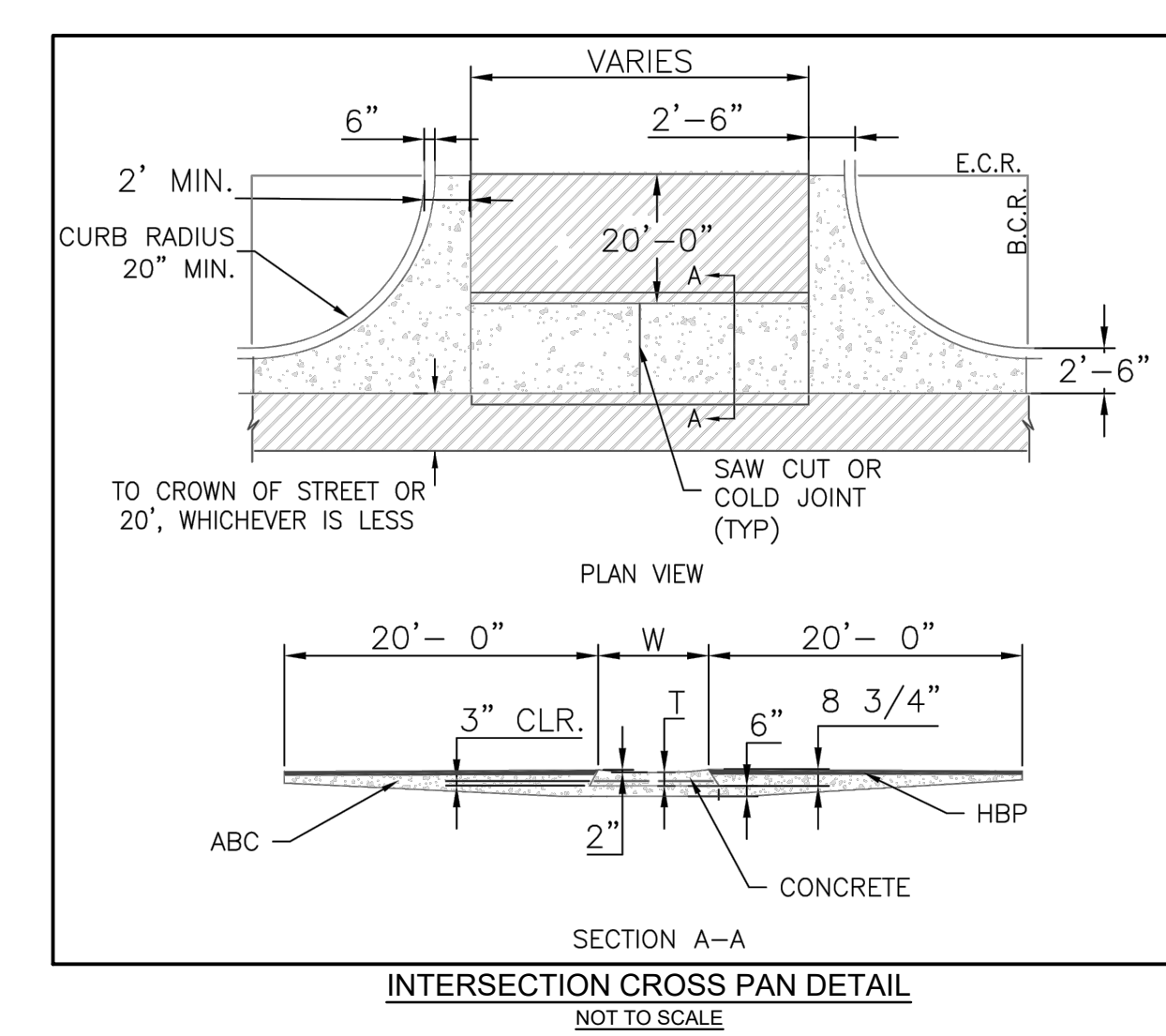

- NOTES:**
- W - WIDTH SHALL BE 6' FOR LOCAL, 8' FOR COLLECTORS, AND 10' FOR ARTERIAL ROADS.
 - T - SQUARED-OFF RETURN TO BE POURED MONOLITHICALLY; 8" PCC FOR LOCAL ROADS, 9" FOR COLLECTORS WITH 6x6 - 4.4 W.W.F. OR #4 REINFORCING BAR @ 18" EACH WAY.
 - 3" = 3" MINIMUM ASPHALT DEPTH (2 LIFTS).
 - DESIGN TO SPECIFY ELEVATIONS AT PI AND PCR.

PRIVATE ROAD BETWEEN MERIDIAN ROAD & MERIDIAN SOL DRIVE

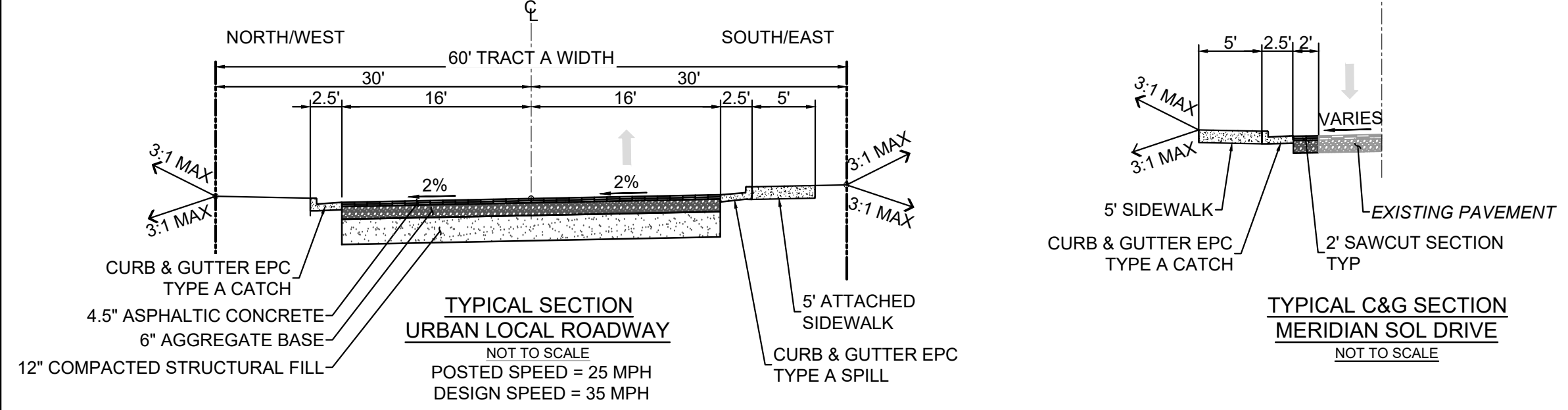

- NOTES:**
- ALL MATERIALS SHOULD MEET THE CURRENT COLORADO DEPARTMENT OF TRANSPORTATION (CDOT) STANDARD SPECIFICATIONS FOR HIGHWAY AND BRIDGE CONSTRUCTION.
 - THE ON-SITE SAND SOILS ARE CONSIDERED SUITABLE FOR USE AS STRUCTURAL FILL.
 - PAVEMENT SECTIONS ARE BASED ON THE GEOTECHNICAL ENGINEERING REPORT AND PAVEMENT THICKNESS DESIGN FOR THE PROPOSED CIRCLE K CONVENIENCE STORE AND FUELING FACILITY AT MERIDIAN CIRCLE K RETAIL STORE IN FALCON, COLORADO BY TERRACON CONSULTANTS, INC. DATED NOVEMBER 30, 2018. FURTHER INVESTIGATION SHOULD BE DONE AFTER GRADING TO CONFIRM WHETHER THE DESIGN ASSUMPTIONS REMAIN APPROPRIATE.

PEDESTRIAN INTERSECTION RAMP DETAIL

NOTE: REFER TO EL PASO COUNTY STANDARD DRAWING SD_2-41

MATERIALS LEGEND

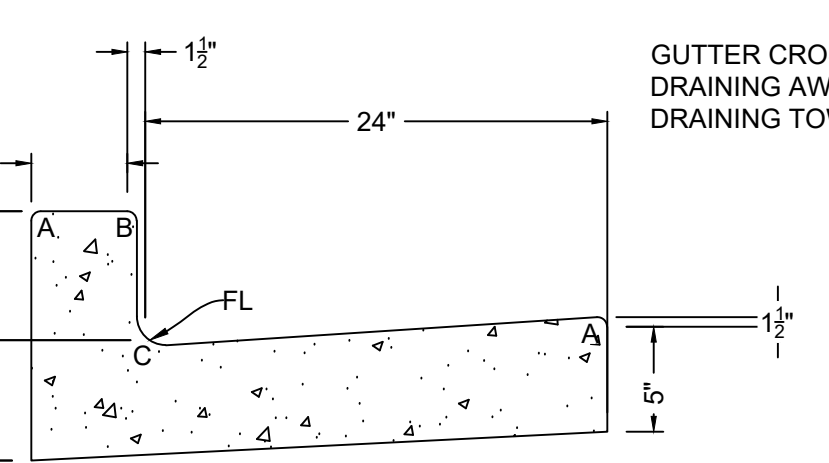
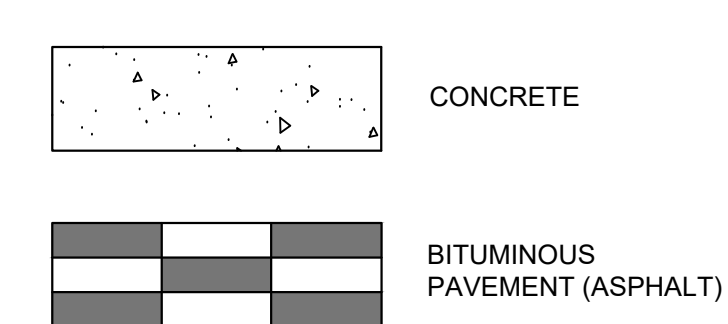

NOTE: REFER TO EL PASO COUNTY STANDARD DRAWING SD_2-20



CONSULTANTS:

Matrix

2435 RESEARCH PARKWAY, SUITE 300
COLORADO SPRINGS, CO 80920
PHONE: (719) 575-0100

LAND DEVELOPMENT CONSULTANTS, LLC

950 S. CHERRY ST., SUITE 512
DENVER, CO 80246

OWNER/DEVELOPER:

CIRCLE K

ROCKY MOUNTAINS DIVISION
5500 S QUEBEC STREET, SUITE 100
GREENWOOD VILLAGE, CO 80111
PHONE: (720) 758-8223

SEAL

FOR AND ON BEHALF OF MATRIX DESIGN GROUP, INC
CONTRACTOR IS RESPONSIBLE FOR OBTAINING THE MOST RECENT PROJECT CONSTRUCTION DOCUMENTS.
MATRIX DESIGN GROUP IS NOT RESPONSIBLE FOR CHANGES, ALTERATIONS, OR USE OF CONSTRUCTION DOCUMENTS PRIOR TO JURISDICTIONAL APPROVAL.

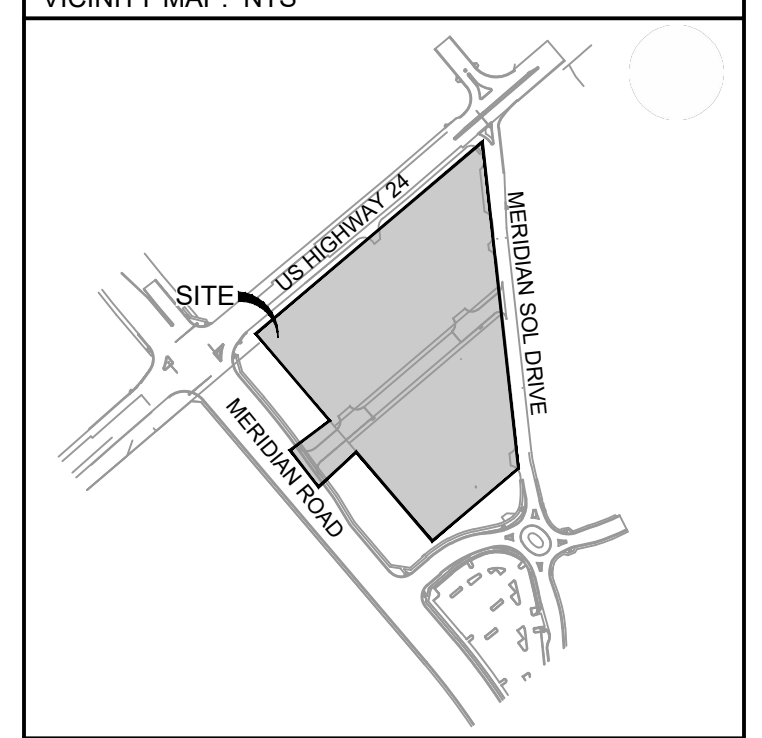

PROJECT:

CIRCLE K STORES INC.

FINAL PLAT OFFSITE CDS

CIRCLE K - US24 & MERIDIAN FALCON, CO

REVISION HISTORY:

NO.	DATE	DESCRIPTION	BY

DRAWING INFORMATION:

PROJECT NO: 21.1207.037

DRAWN BY: RPD

CHECKED BY: NMS

DESIGNED BY: NMS

SHEET TITLE:

GENERAL NOTES

SHEET 4 OF 14

GN03

PCD FILING NO.: VR-22-03

ISSUE DATE: JANUARY 2023

FILE LOCATION: S:\CIRCLE K\HWY 24 & MERIDIAN\DWG\PLAN SETS\OFF-SITE CDS\GN03.DWG

FILE LOCATION: S:\CIRCLE K HWY 24 & MERIDIAN\DWG\PLAN SETS\OFF-SITE\CD\DM01.DWG

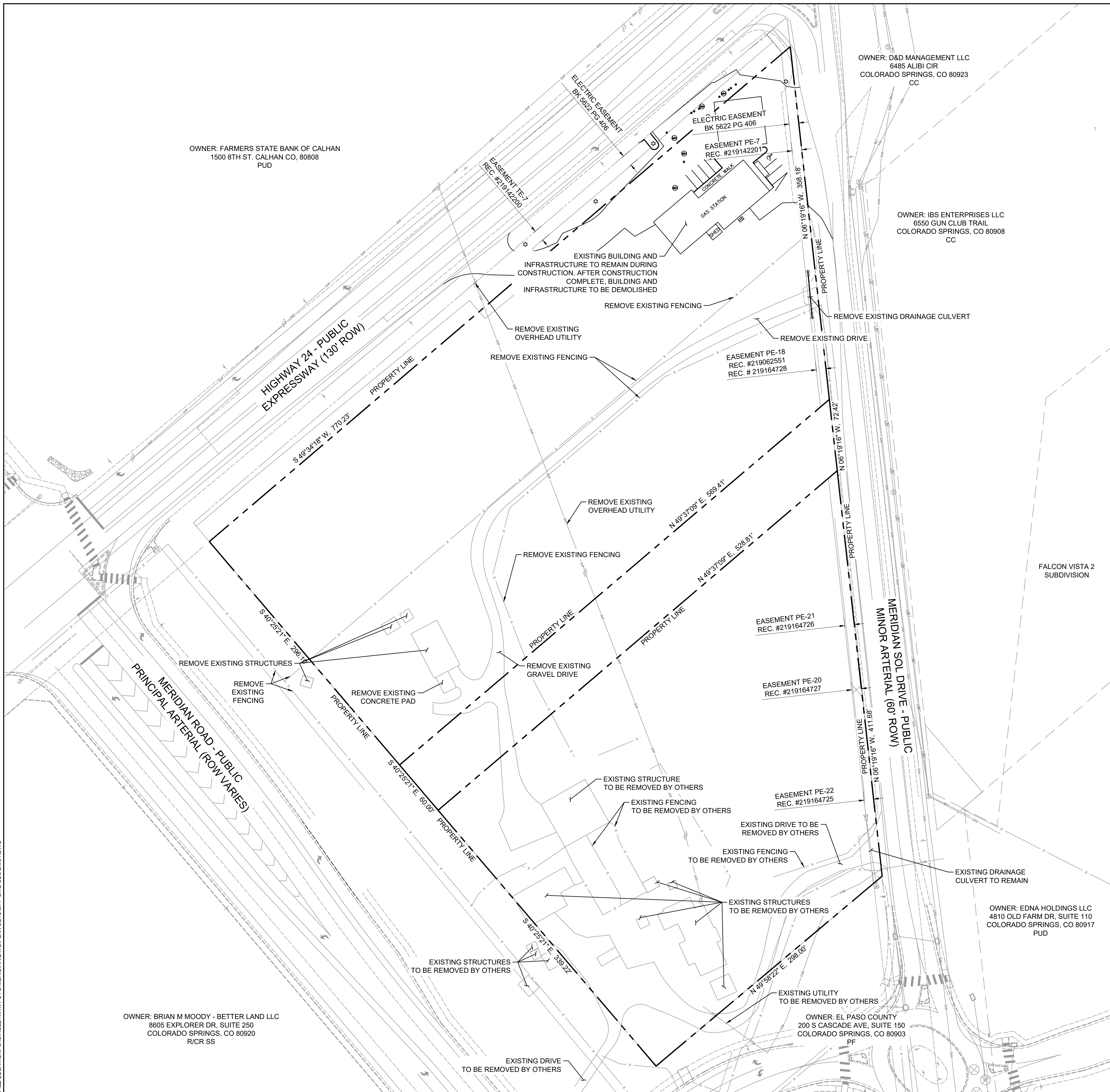

OWNER: FARMERS STATE BANK OF CALHAN
1500 8TH ST. CALHAN CO. 80808
PUD

OWNER: D&D MANAGEMENT LLC
6485 ALIBI CIR
COLORADO SPRINGS, CO 80923
CC

OWNER: IBS ENTERPRISES LLC
6550 GUN CLUB TRAIL
COLORADO SPRINGS, CO 80908
CC

OWNER: BRIAN M MOODY - BETTER LAND LLC
8605 EXPLORER DR, SUITE 250
COLORADO SPRINGS, CO 80920
R/CR SS

OWNER: EL PASO COUNTY
200 S CASCADE AVE, SUITE 150
COLORADO SPRINGS, CO 80903
PF

OWNER: EDNA HOLDINGS LLC
4810 OLD FARM DR, SUITE 110
COLORADO SPRINGS, CO 80917
PUD



CONSULTANTS:
Matrix
2435 RESEARCH PARKWAY, SUITE 300
COLORADO SPRINGS, CO 80920
PHONE: (719) 575-0100

LAND DEVELOPMENT
CONSULTANTS, LLC
950 S. CHERRY ST., SUITE 512
DENVER, CO 80246

OWNER/DEVELOPER:
CIRCLE K
ROCKY MOUNTAINS DIVISION
5500 S QUEBEC STREET, SUITE 100
GREENWOOD VILLAGE, CO 80111
PHONE: (720) 758-8223

SEAL

FOR AND ON BEHALF OF MATRIX DESIGN GROUP, INC
CONTRACTOR IS RESPONSIBLE FOR OBTAINING THE MOST RECENT PROJECT CONSTRUCTION DOCUMENTS. MATRIX DESIGN GROUP IS NOT RESPONSIBLE FOR CHANGES, ALTERATIONS, OR USE OF CONSTRUCTION DOCUMENTS PRIOR TO JURISDICTIONAL APPROVAL.

VICINITY MAP: NTS

PROJECT:
CIRCLE K STORES INC.
FINAL PLAT OFFSITE CDS
CIRCLE K - US 24 & MERIDIAN
FALCON, CO

REVISION HISTORY:

NO.	DATE	DESCRIPTION	BY

DRAWING INFORMATION:
PROJECT NO: 21.1207.037
DRAWN BY: RPD
CHECKED BY: NMS
DESIGNED BY: NMS

DEMOLITION PLAN

SHEET 5 OF 14
DM01

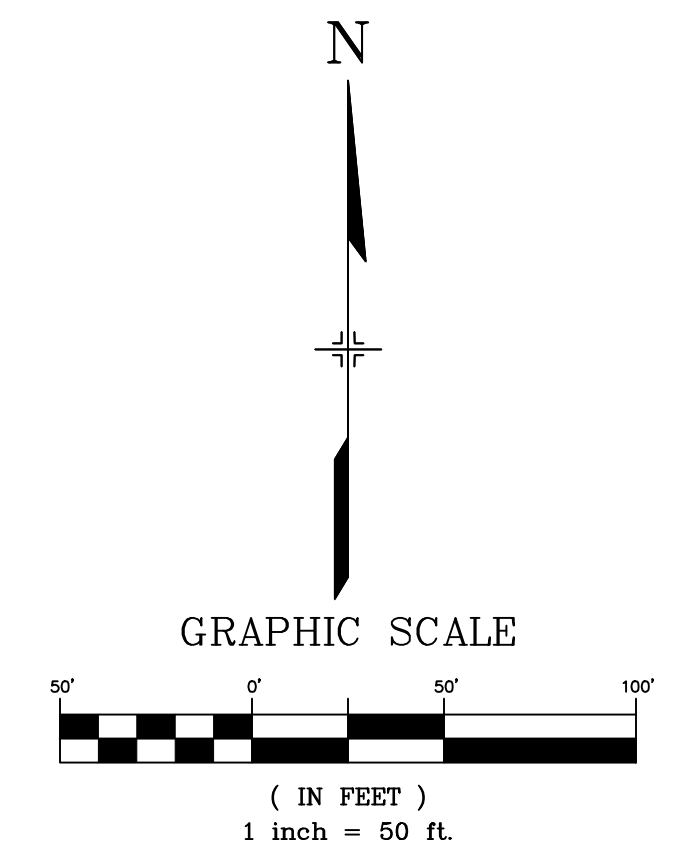



CONSULTANTS:

 2435 RESEARCH PARKWAY, SUITE 300
 COLORADO SPRINGS, CO 80920
 PHONE: (719) 575-0100

LAND DEVELOPMENT CONSULTANTS, LLC
 950 S. CHERRY ST., SUITE 512
 DENVER, CO 80246

OWNER/DEVELOPER:

 ROCKY MOUNTAINS DIVISION
 5500 S QUEBEC STREET, SUITE 100
 GREENWOOD VILLAGE, CO 80111
 PHONE: (720) 758-8223

SEAL

FOR AND ON BEHALF OF MATRIX DESIGN GROUP, INC
 CONTRACTOR IS RESPONSIBLE FOR OBTAINING THE MOST RECENT PROJECT CONSTRUCTION DOCUMENTS. MATRIX DESIGN GROUP IS NOT RESPONSIBLE FOR CHANGES, ALTERATIONS, OR USE OF CONSTRUCTION DOCUMENTS PRIOR TO JURISDICTIONAL APPROVAL.

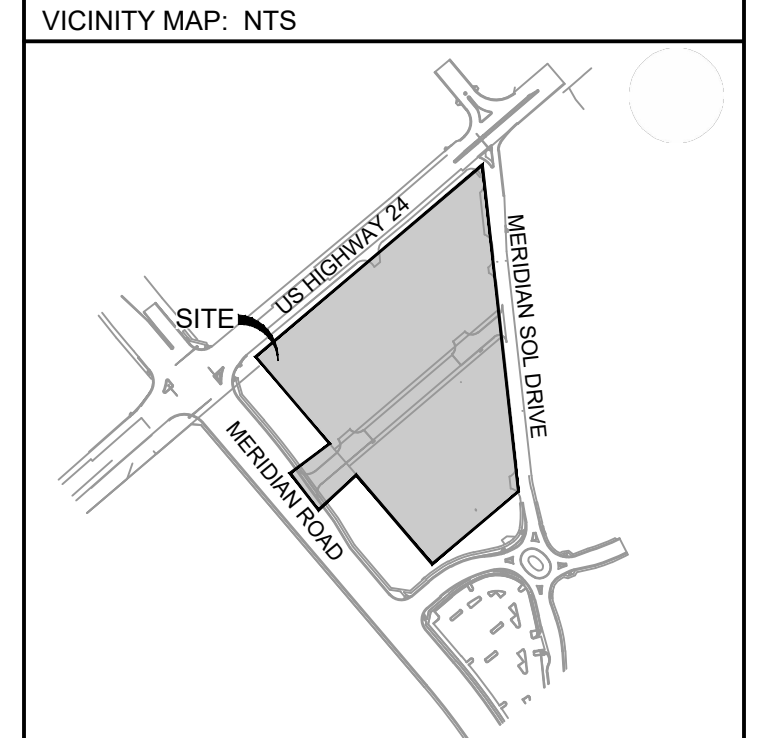

PROJECT:
CIRCLE K STORES INC.

FINAL PLAT OFFSITE CDS

CIRCLE K - US24 & MERIDIAN FALCON, CO

REVISION HISTORY:

NO.	DATE	DESCRIPTION	BY

DRAWING INFORMATION:
 PROJECT NO: 21.1207.037
 DRAWN BY: RPD
 CHECKED BY: NMS
 DESIGNED BY: NMS

ROADWAY PLAN & PROFILE

SHEET 6 OF 14
 RD01

ISSUE DATE: JANUARY 2023

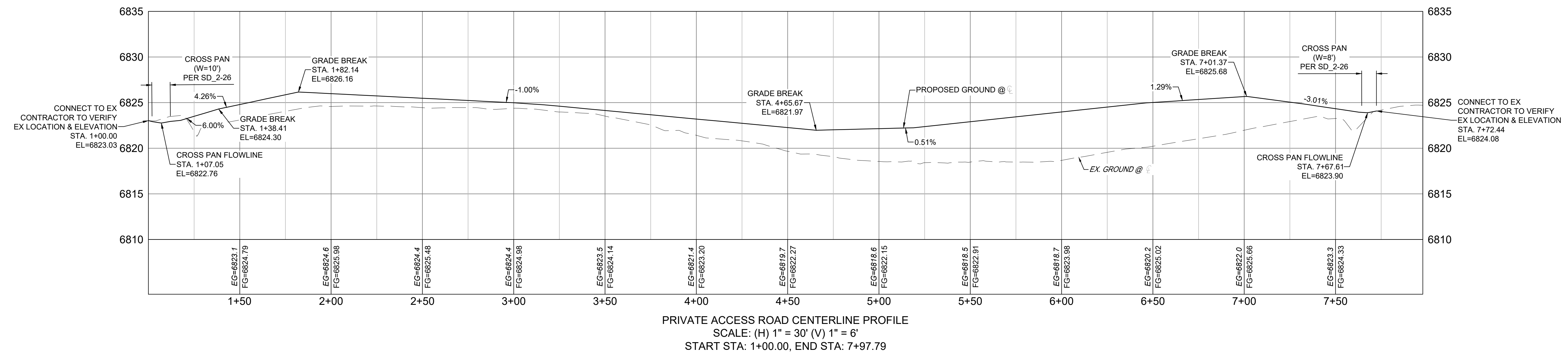
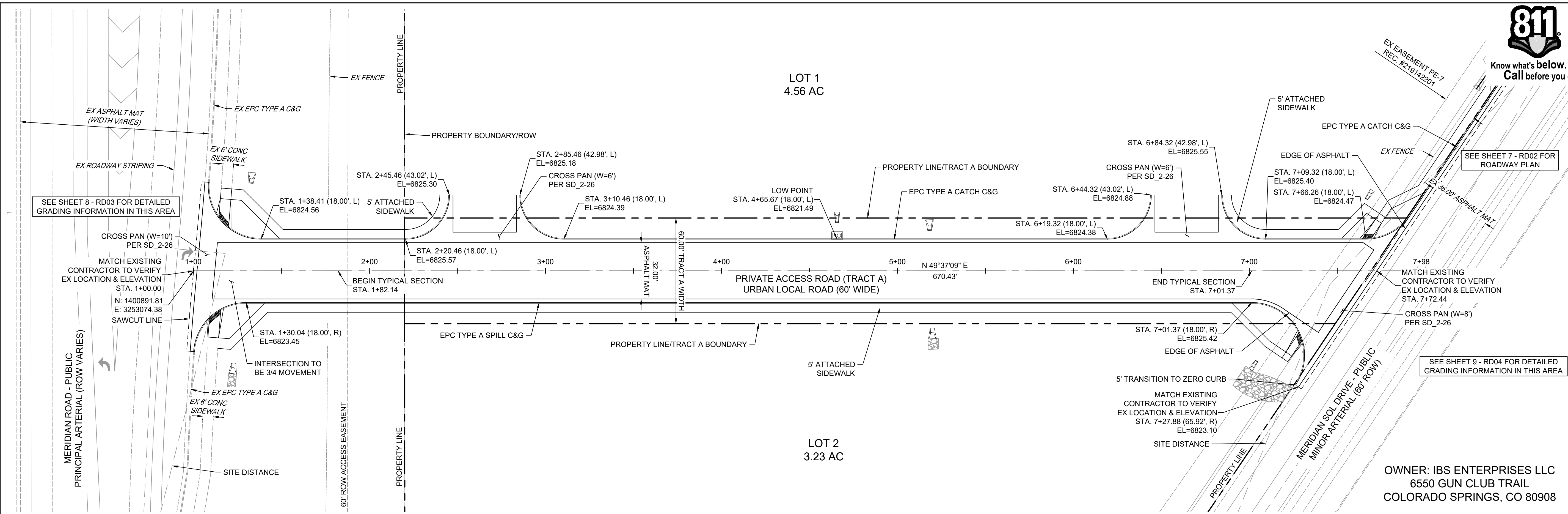

PRIVATE ACCESS ROAD CENTERLINE PROFILE
 SCALE: (H) 1" = 30' (V) 1" = 6'
 START STA: 1+00.00, END STA: 7+97.79

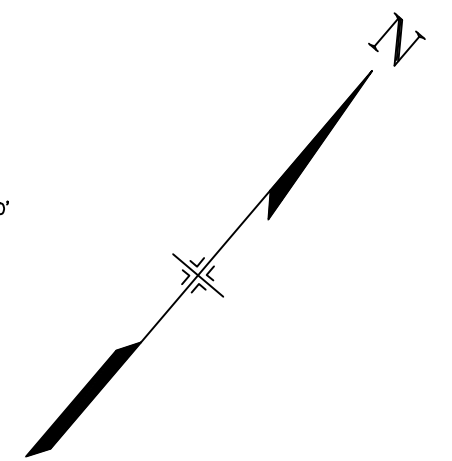
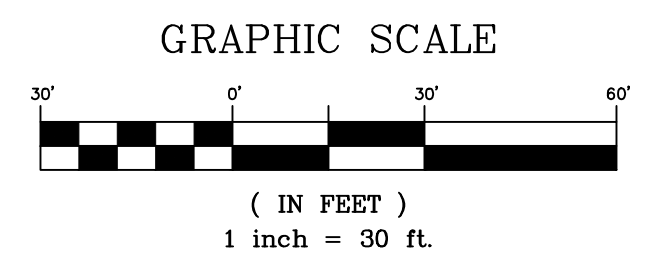

FILE LOCATION: S:\CIRCLE K HWY 24 & MERIDIAN\DWG\PLAN SETS\OFF-SITE CDS\RD01.DWG



Matrix
 2435 RESEARCH PARKWAY, SUITE
 300 COLORADO SPRINGS, CO 80920
 PHONE: (719) 575-0100

LAND DEVELOPMENT
 CONSULTANTS, LLC
 950 S. CHERRY ST., SUITE 512
 DENVER, CO 80246

OWNER/DEVELOPER:
CIRCLE K
 ROCKY MOUNTAINS DIVISION
 5500 S QUEBEC STREET, SUITE 100
 GREENWOOD VILLAGE, CO 80111
 PHONE: (720) 758-8223

SEAL

 FOR AND ON BEHALF OF MATRIX DESIGN GROUP, INC
 CONTRACTOR IS RESPONSIBLE FOR OBTAINING THE
 MOST RECENT PROJECT CONSTRUCTION DOCUMENTS.
 MATRIX DESIGN GROUP IS NOT RESPONSIBLE FOR
 CHANGES, ALTERATIONS, OR USE OF CONSTRUCTION
 DOCUMENTS PRIOR TO JURISDICTIONAL APPROVAL.

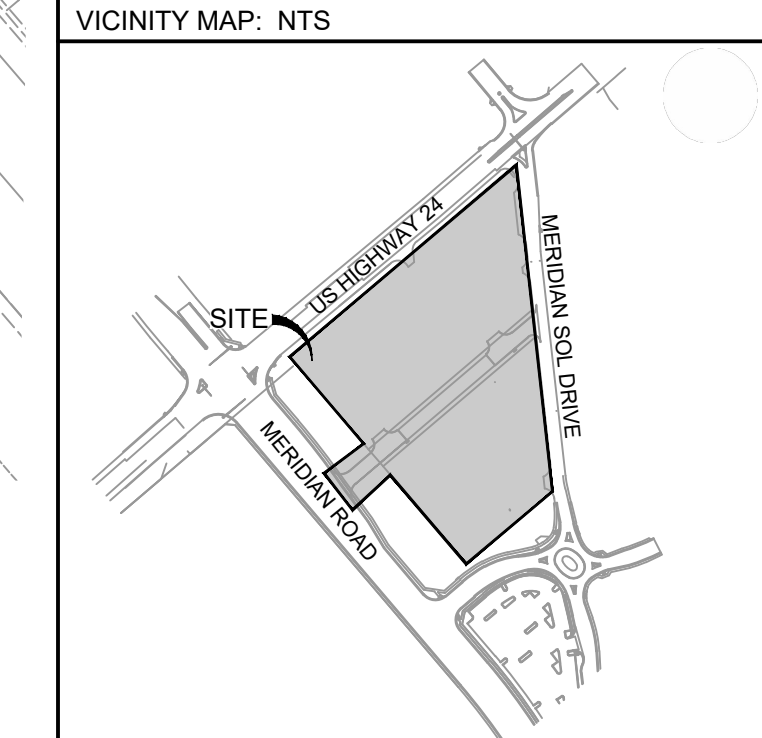

PROJECT:
CIRCLE K STORES INC.
 FINAL PLAT OFFSITE CDS
 CIRCLE K - US24 & MERIDIAN
 FALCON, CO

REVISION HISTORY:

NO.	DATE	DESCRIPTION	BY

DRAWING INFORMATION:
 PROJECT NO: 21.1207.037
 DRAWN BY: RPD
 CHECKED BY: NMS
 DESIGNED BY: NMS

ROADWAY PLAN

SHEET 7 OF 14
 RD02

PCD FILING NO.: VR-22-03 ISSUE DATE: JANUARY 2023

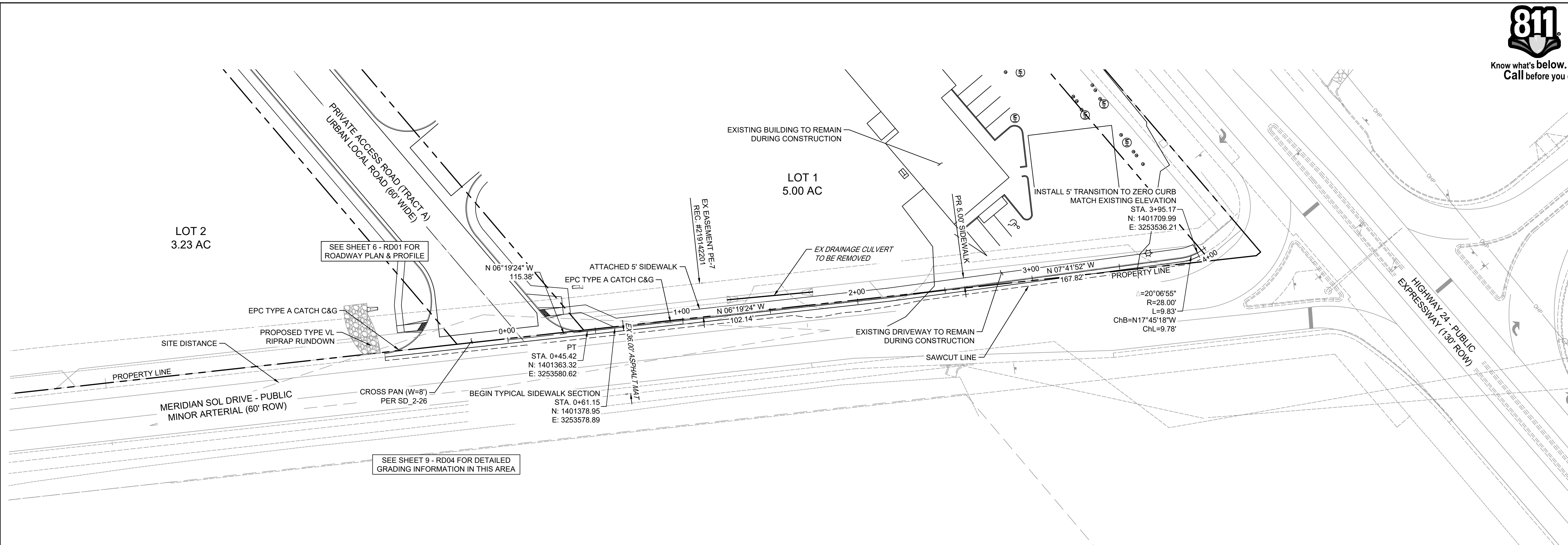

OWNER: IBS ENTERPRISES LLC
 6550 GUN CLUB TRAIL
 COLORADO SPRINGS, CO 80908

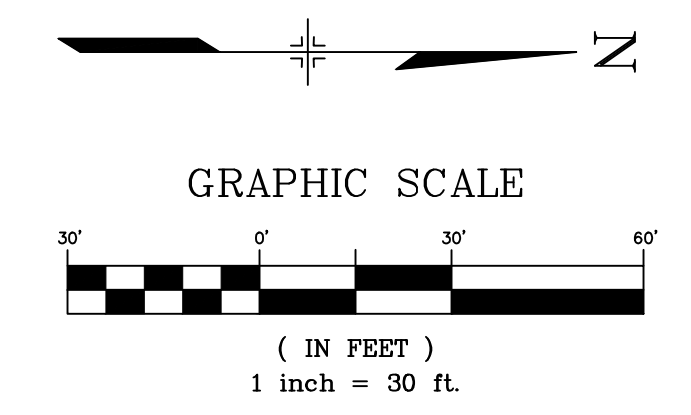
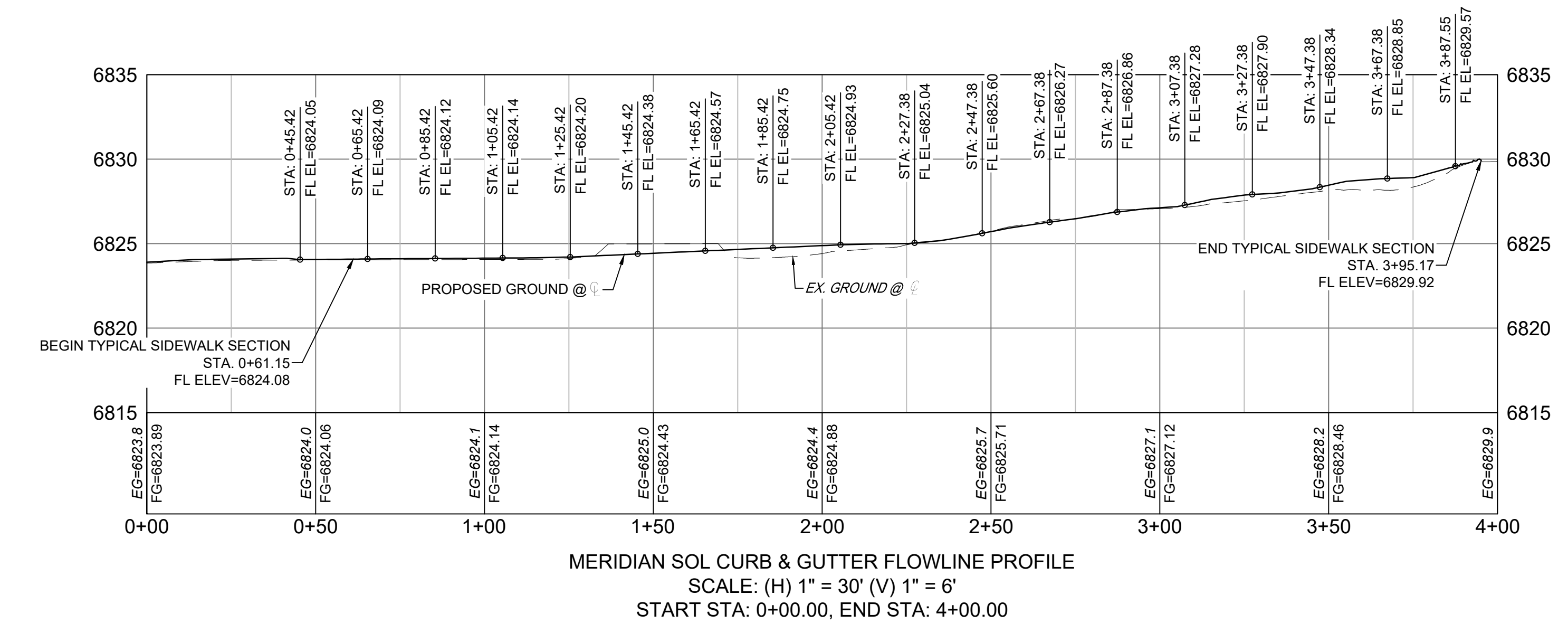

FILE LOCATION: S:\CIRCLE K HWY 24 & MERIDIAN\RD02\PLAN SETS\OFF-SITE\CD\RD02.DWG

FILE LOCATION: S:\CIRCLE K\HWY 24 & MERIDIAN\PLAN SETS\OFF-SITE CD\RD01.DWG

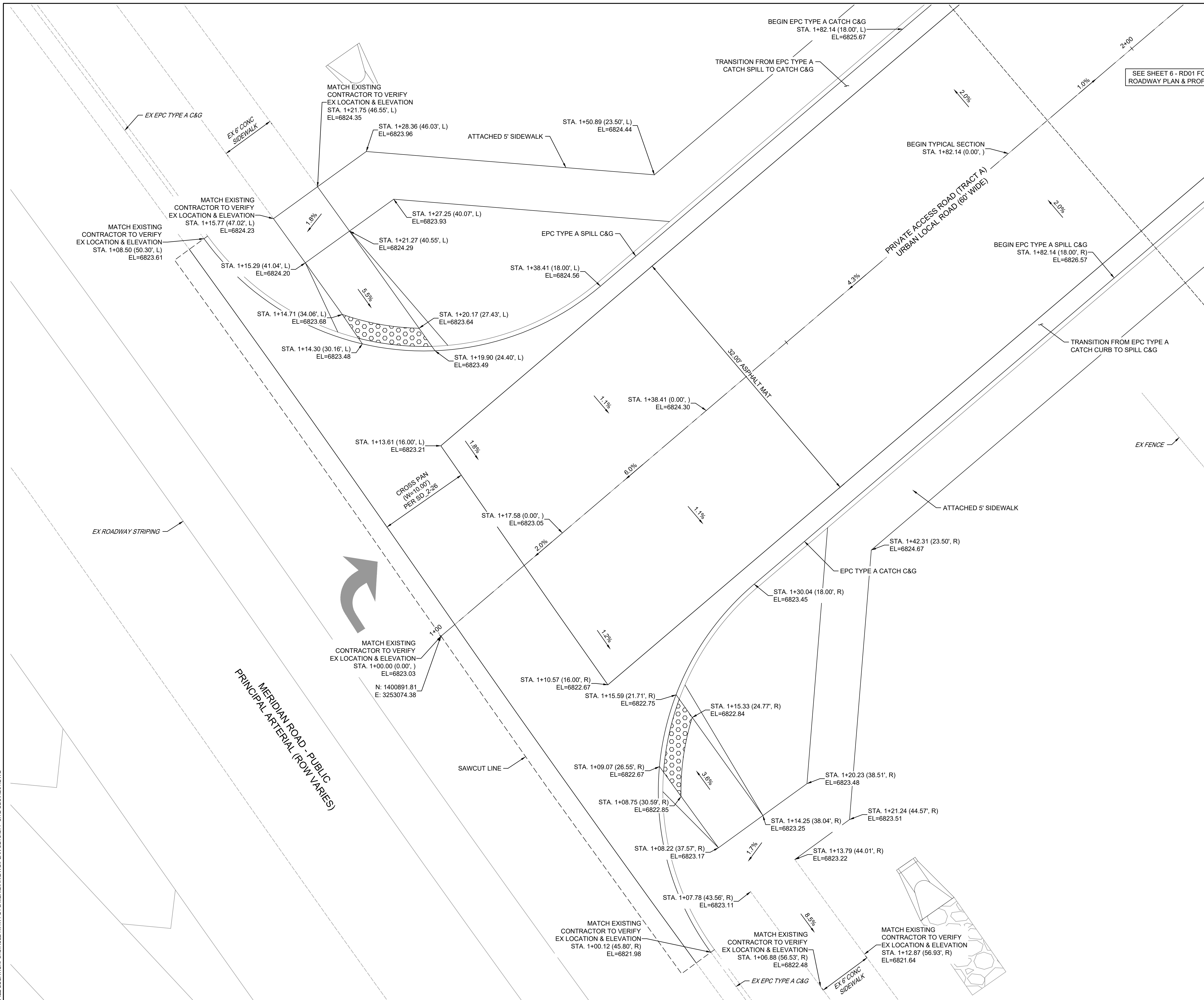

Matrix
 2435 RESEARCH PARKWAY, SUITE
 300 COLORADO SPRINGS, CO 80920
 PHONE: (719) 575-0100

LAND DEVELOPMENT
 CONSULTANTS, LLC
 950 S. CHERRY ST., SUITE 512
 DENVER, CO 80246

OWNER/DEVELOPER:
CIRCLE K
 ROCKY MOUNTAINS DIVISION
 5500 S QUEBEC STREET, SUITE 100
 GREENWOOD VILLAGE, CO 80111
 PHONE: (720) 758-8223

SEAL

 FOR AND ON BEHALF OF MATRIX DESIGN GROUP, INC
 CONTRACTOR IS RESPONSIBLE FOR OBTAINING THE
 MOST RECENT PROJECT CONSTRUCTION DOCUMENTS.
 MATRIX DESIGN GROUP IS NOT RESPONSIBLE FOR
 CHANGES, ALTERATIONS, OR USE OF CONSTRUCTION
 DOCUMENTS PRIOR TO JURISDICTIONAL APPROVAL.

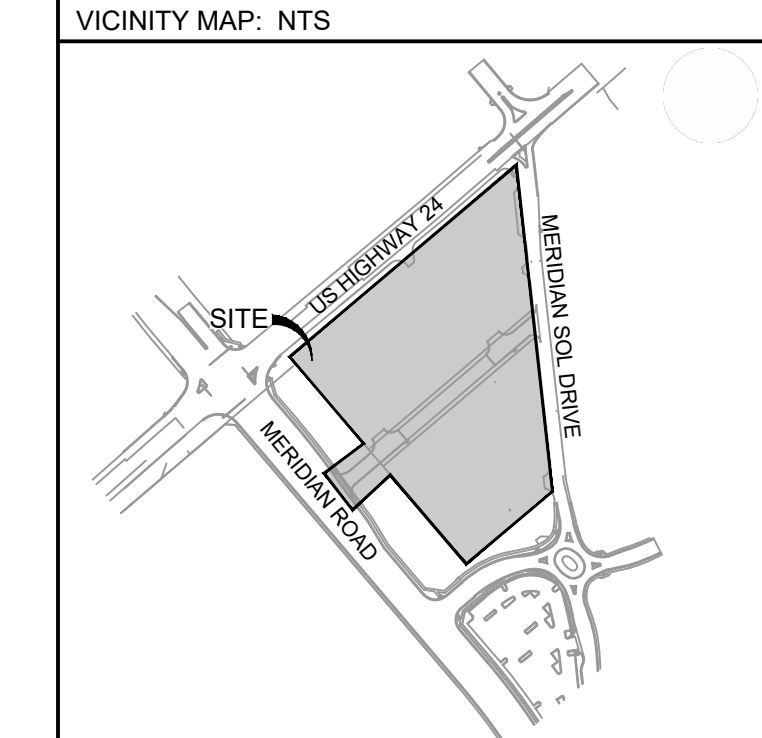

PROJECT:
CIRCLE K STORES INC.
 FINAL PLAT OFFSITE CDS
 CIRCLE K - US24 & MERIDIAN
 FALCON, CO

REVISION HISTORY:

NO.	DATE	DESCRIPTION	BY

DRAWING INFORMATION:
 PROJECT NO: 21.1207.037
 DRAWN BY: RPD
 CHECKED BY: NMS
 DESIGNED BY: NMS

**DETAILED ROAD
 GRADING PLAN
 (WEST
 ENTRANCE)**

SHEET 8 OF 14
 RD03
 ISSUE DATE: JANUARY 2023

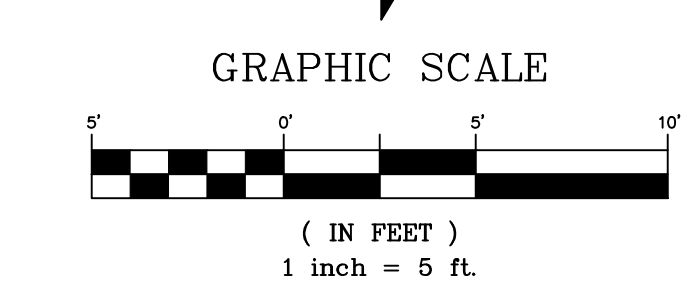

PCD FILING NO.: VR-22-03



Know what's below.
Call before you dig.



2435 RESEARCH PARKWAY, SUITE
300 COLORADO SPRINGS, CO 80920
PHONE: (719) 575-0100



LAND DEVELOPMENT
CONSULTANTS, LLC

950 S. CHERRY ST., SUITE 512
DENVER, CO 80246

OWNER/DEVELOPER:



ROCKY MOUNTAINS DIVISION
5500 S QUEBEC STREET, SUITE 100
GREENWOOD VILLAGE, CO 80111
PHONE: (720) 758-8223

SEAL



FOR AND ON BEHALF OF MATRIX DESIGN GROUP, INC
CONTRACTOR IS RESPONSIBLE FOR OBTAINING THE
MOST RECENT PROJECT CONSTRUCTION DOCUMENTS.
MATRIX DESIGN GROUP IS NOT RESPONSIBLE FOR
CHANGES, ALTERATIONS, OR USE OF CONSTRUCTION
DOCUMENTS PRIOR TO JURISDICTIONAL APPROVAL.

VICINITY MAP: NTS

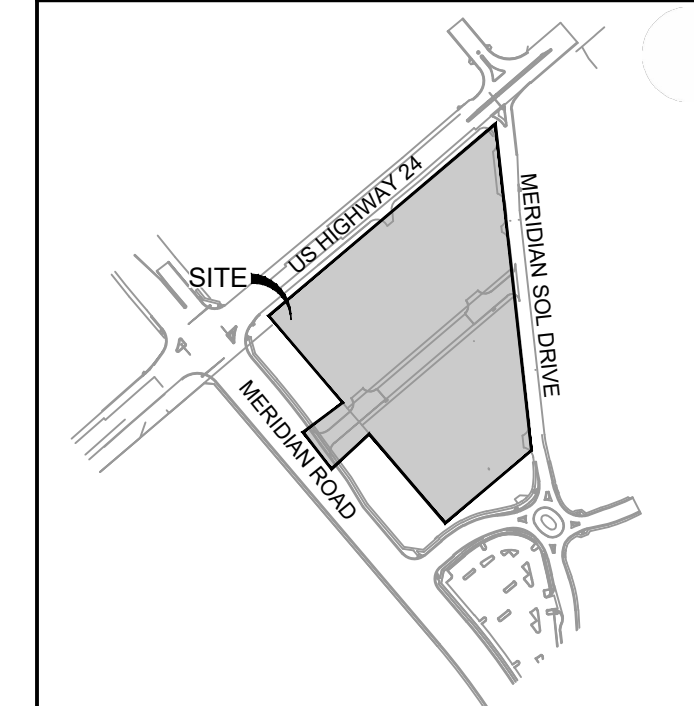

PROJECT:

CIRCLE K STORES INC.

FINAL PLAT OFFSITE CDS

CIRCLE K - US24 & MERIDIAN
FALCON, CO

REVISION HISTORY:

NO.	DATE	DESCRIPTION	BY

DRAWING INFORMATION:

PROJECT NO: 21.1207.037

DRAWN BY: RPD

CHECKED BY: NMS

DESIGNED BY: NMS

SHEET TITLE:

**DETAILED ROAD
GRADING PLAN
(EAST
ENTRANCE)**

SHEET 9 OF 14
RD04

ISSUE DATE: JANUARY 2023

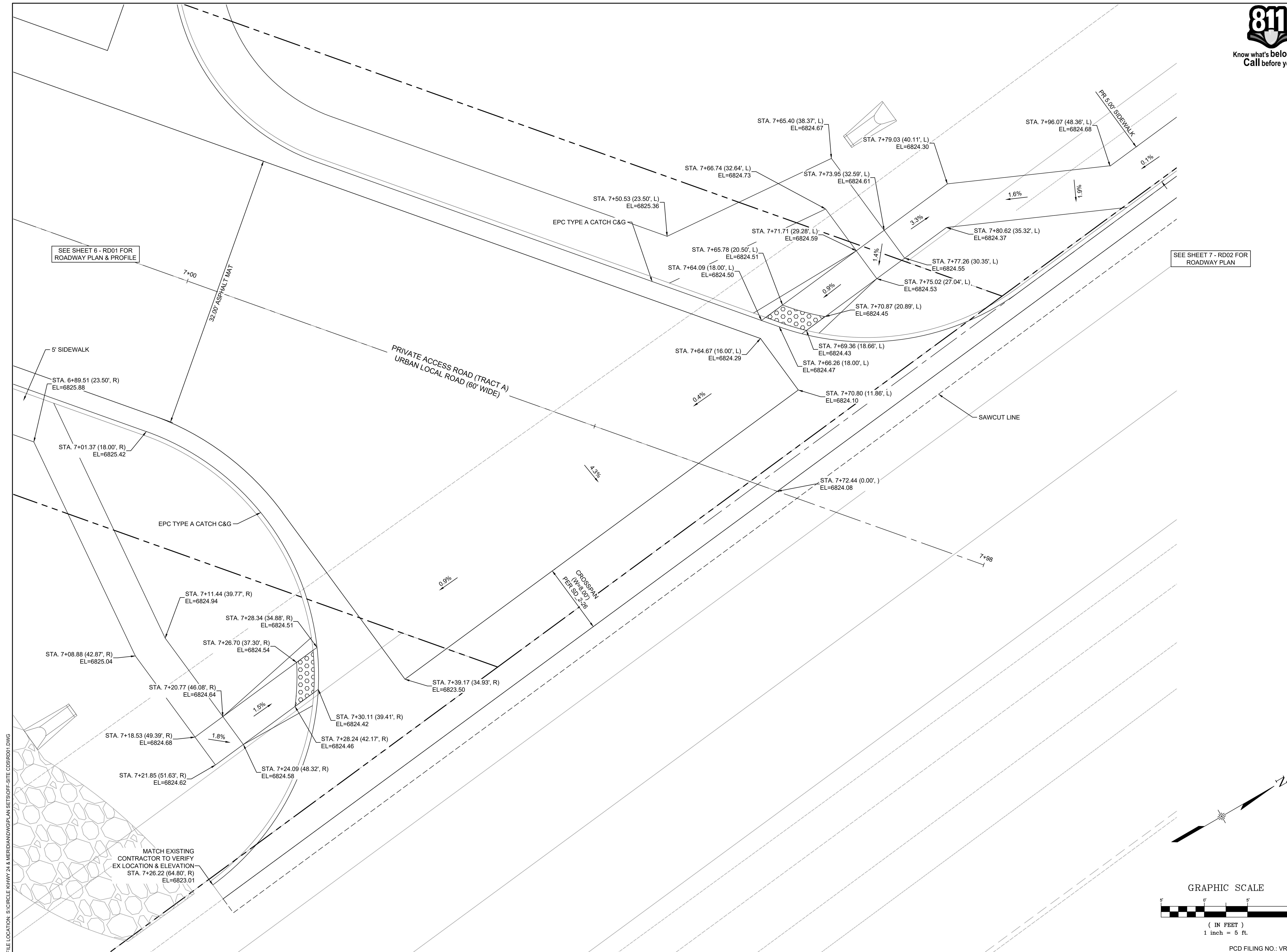

FILE LOCATION: S:\CIRCLE K HWY 24 & MERIDIAN\DWG\PLAN\SET\OFF-SITE CD\RD04.DWG

PCD FILING NO.: VR-22-03



CONSULTANTS:

 2435 RESEARCH PARKWAY, SUITE 300
 COLORADO SPRINGS, CO 80920
 PHONE: (719) 575-0100

LAND DEVELOPMENT CONSULTANTS, LLC
 950 S. CHERRY ST., SUITE 512
 DENVER, CO 80246

OWNER/DEVELOPER:

 ROCKY MOUNTAINS DIVISION
 5500 S. QUEBEC STREET, SUITE 100
 GREENWOOD VILLAGE, CO 80111
 PHONE: (720) 758-8223

SEAL

 FOR AND ON BEHALF OF MATRIX DESIGN GROUP, INC
 CONTRACTOR IS RESPONSIBLE FOR OBTAINING THE MOST RECENT PROJECT CONSTRUCTION DOCUMENTS.
 MATRIX DESIGN GROUP IS NOT RESPONSIBLE FOR CHANGES, ALTERATIONS, OR USE OF CONSTRUCTION DOCUMENTS PRIOR TO JURISDICTIONAL APPROVAL.

VICINITY MAP: NTS

PROJECT:
CIRCLE K STORES INC.
 FINAL PLAT OFFSITE CDS
 CIRCLE K - US24 & MERIDIAN FALCON, CO

REVISION HISTORY:

NO.	DATE	DESCRIPTION	BY

DRAWING INFORMATION:
 PROJECT NO: 21.1207.037
 DRAWN BY: RPD
 CHECKED BY: NMS
 DESIGNED BY: NMS

STORM DRAIN PLAN & PROFILE

SHEET 10 OF 14
 SD01

ISSUE DATE: JANUARY 2023

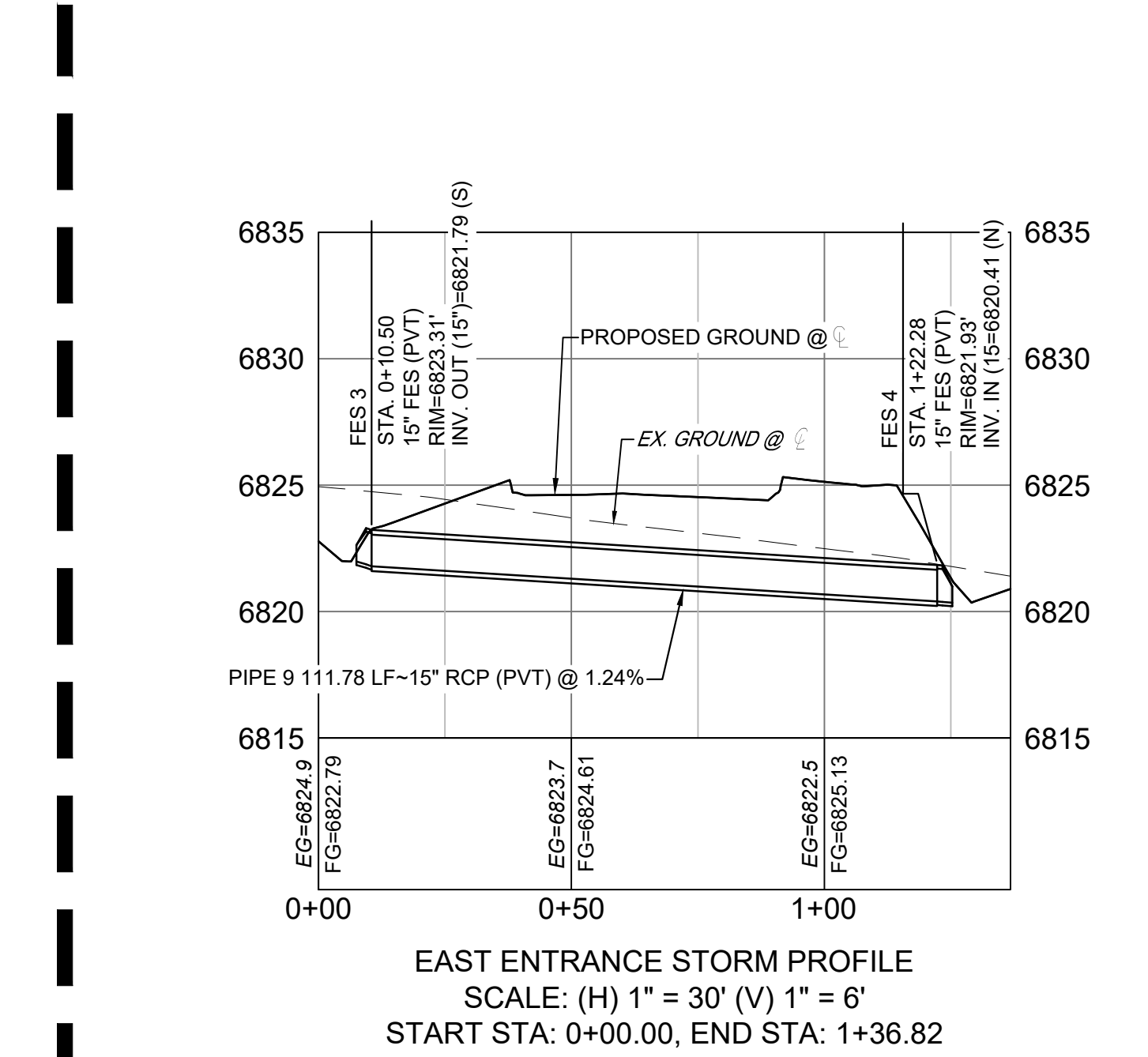
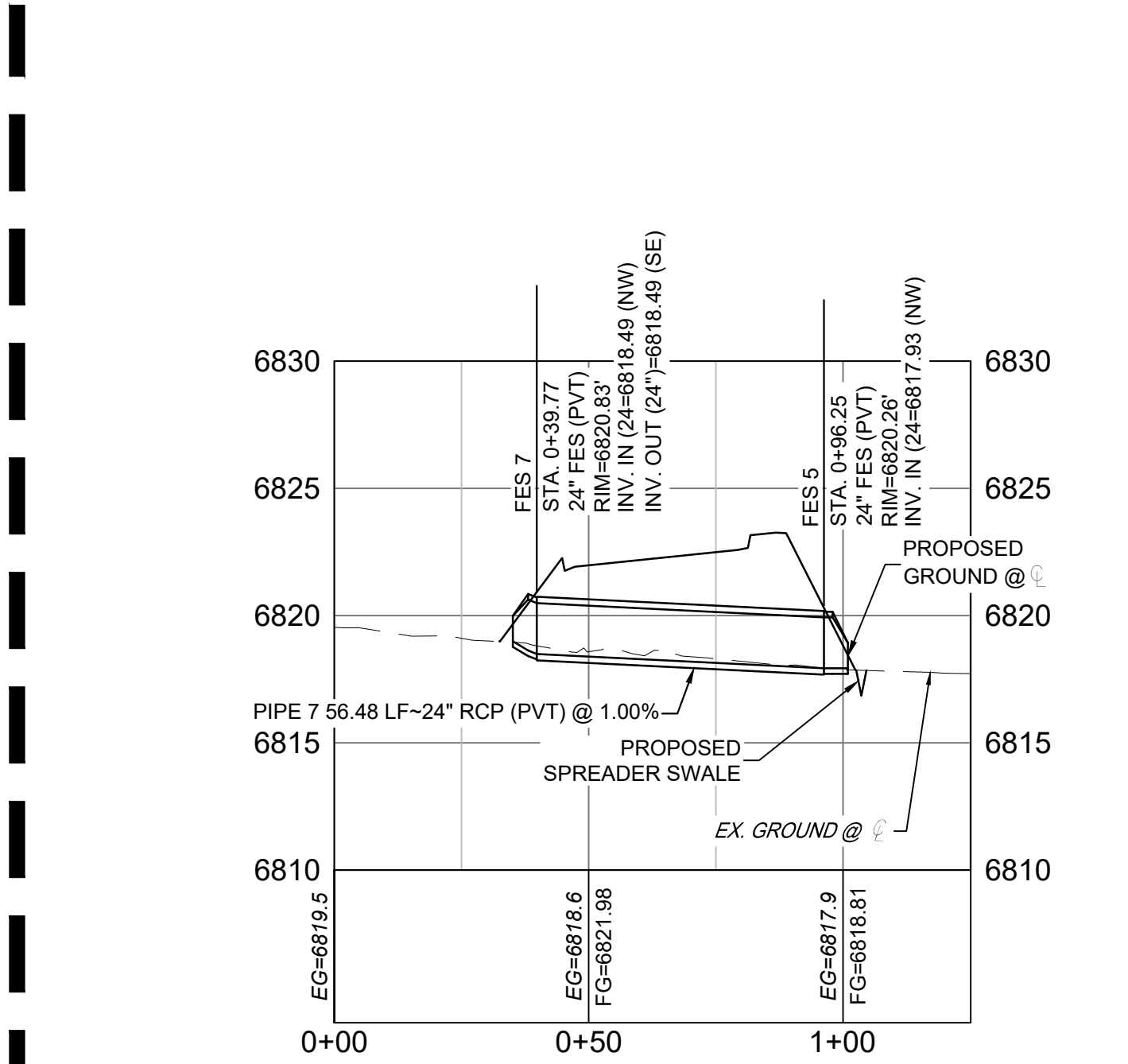
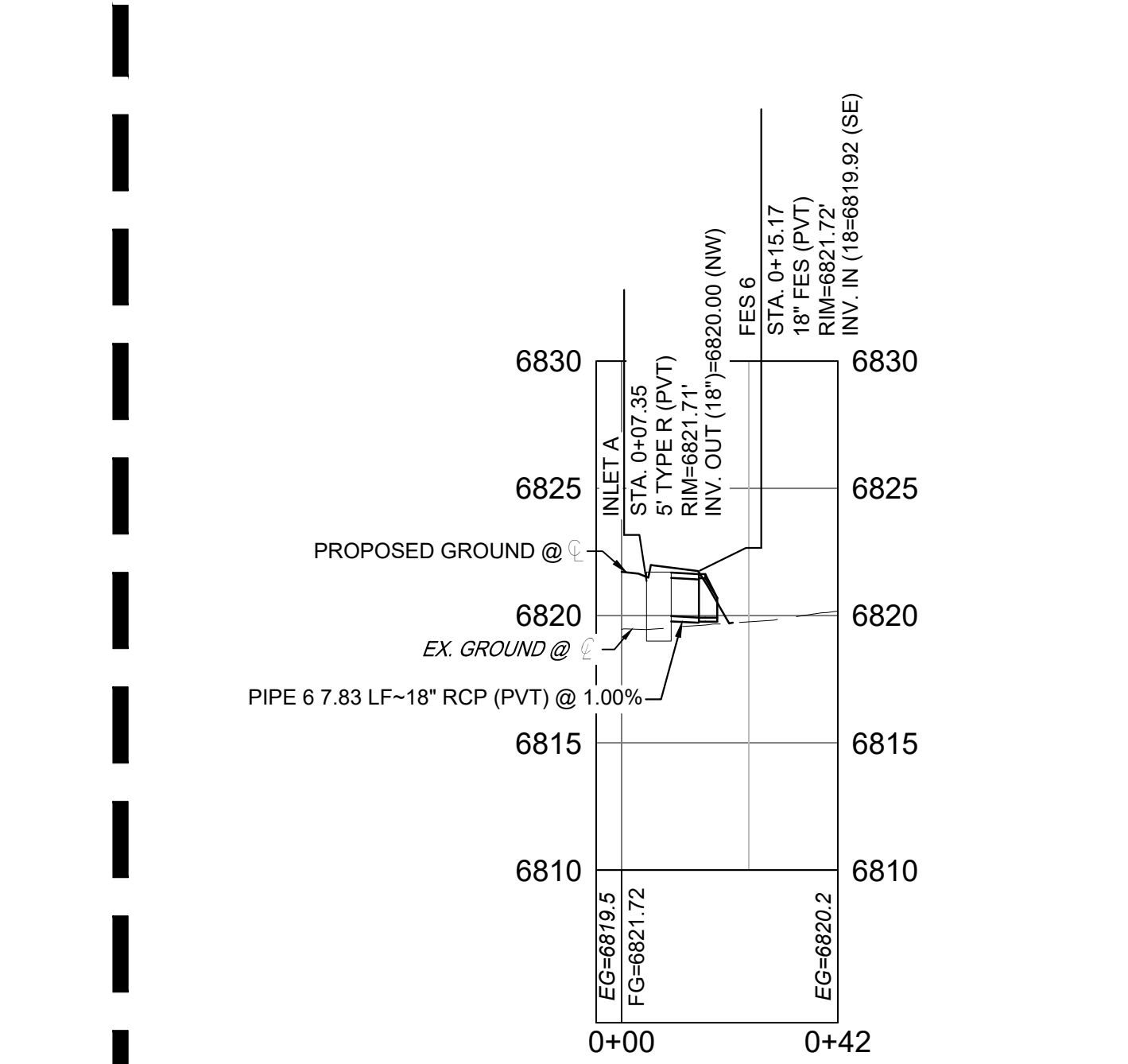
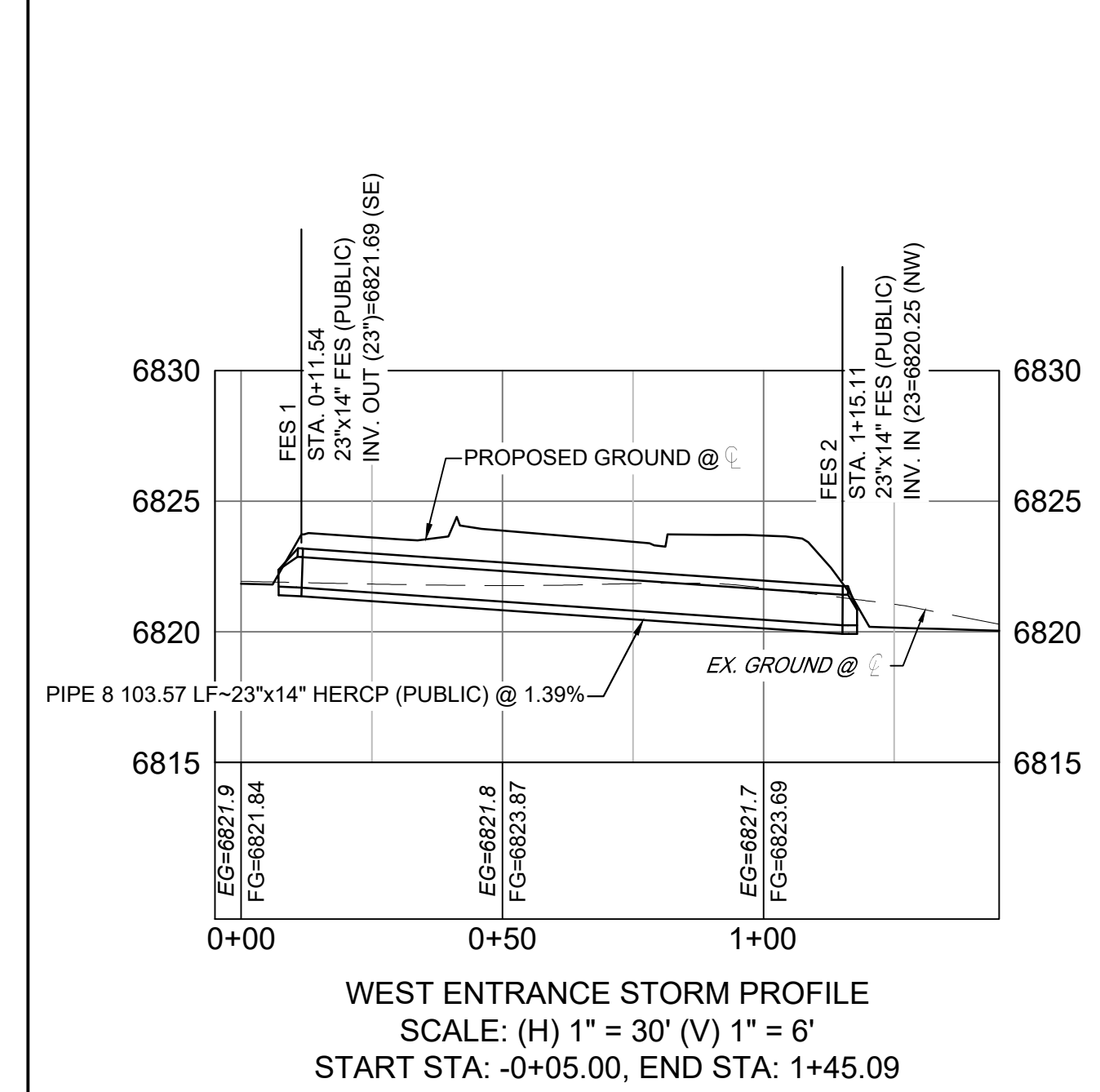
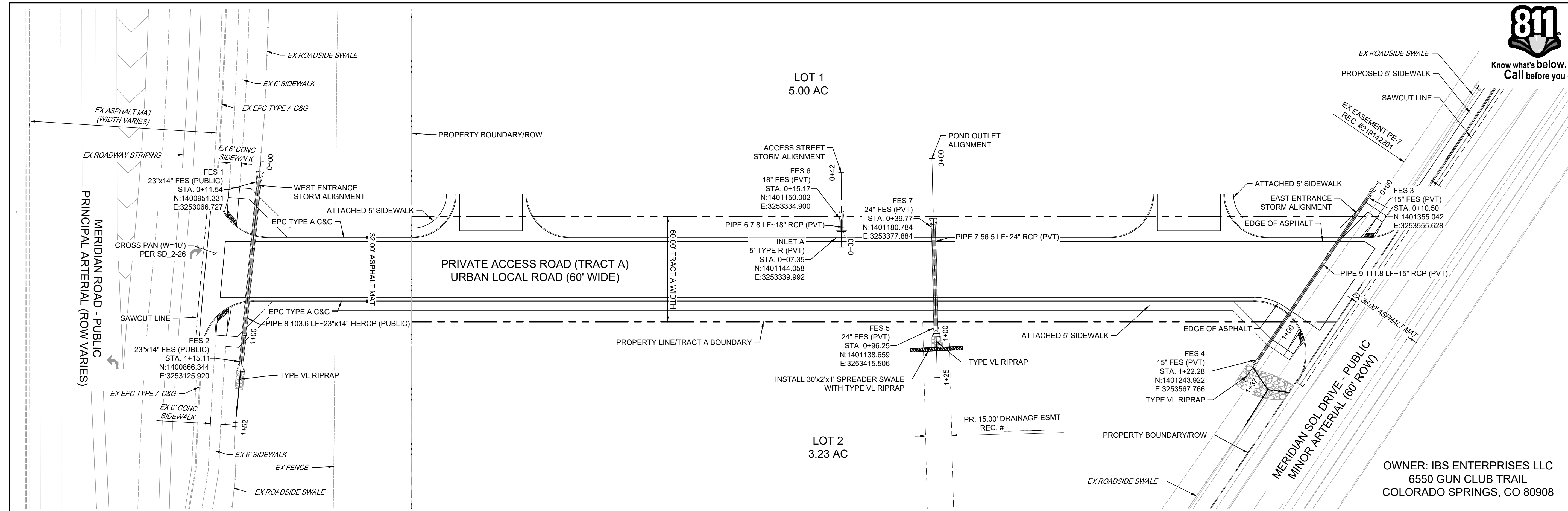

STRUCTURE TABLE

NAME	TYPE	DETAILS	N & E
FES 1	23"x14" FES (PUBLIC)	RIM = 6823.27 PIPE 8 INV OUT (23") = 6821.69	N: 1400951.33 E: 3253066.73
FES 2	23"x14" FES (PUBLIC)	RIM = 6821.84 PIPE 8 INV IN (23") = 6820.25	N: 1400866.34 E: 3253125.92
FES 3	15" FES (PVT)	RIM = 6823.31 PIPE 9 INV OUT (15") = 6821.79	N: 1401355.04 E: 3253555.63
FES 4	15" FES (PVT)	RIM = 6821.93 PIPE 9 INV IN (15") = 6820.41	N: 1401243.92 E: 3253567.77
FES 5	24" FES (PVT)	RIM = 6820.26 PIPE 7 INV IN (24") = 6817.93	N: 1401138.66 E: 3253415.51
FES 6	18" FES (PVT)	RIM = 6821.72 PIPE 6 INV IN (18") = 6819.92	N: 1401150.00 E: 3253334.90
FES 7	24" FES (PVT)	RIM = 6820.83 PIPE 12 INV IN (24") = 6818.49 PIPE 7 INV OUT (24") = 6818.49	N: 1401180.78 E: 3253377.88
INLET A	5" TYPE R (PVT)	RIM = 6821.71 PIPE 6 INV OUT (18") = 6820.00	N: 1401144.06 E: 3253339.99

PIPE TABLE

PIPE NAME	BEARING	LENGTH	SLOPE	SIZE
PIPE 6	N40°35'14"W	7.8'	1.00%	18" RCP (PVT)
PIPE 7	S41°46'04"E	56.5'	1.00%	24" RCP (PVT)
PIPE 8	S34°51'26"E	103.6'	1.39%	23"x14" HERCP (PUBLIC)
PIPE 9	S06°14'02"E	111.8'	1.24%	15" RCP (PVT)

NOTES:
 1. ALL STATION, OFFSET, NORTHING AND EASTING VALUES ARE TO THE CENTER OF ALL STRUCTURES UNLESS OTHERWISE NOTED.
 2. PIPE LENGTHS ARE MEASURED FROM CENTER TO CENTER OF ALL STRUCTURES.
 3. CONTRACTOR TO FIELD VERIFY HORIZONTAL AND VERTICAL LOCATION OF EXISTING STRUCTURES.
 4. ALL RCP PIPE SHALL BE CLASS III UNLESS OTHERWISE NOTED.
 5. PIPES OF DIFFERENT SIZES ARE TO BE MATCHED TO THE CROWN OF THE INSIDE WALL OF PIPE.
 6. PER THE EL PASO COUNTY ENGINEERING CRITERIA MANUAL, MANHOLES SHALL BE INSTALLED 1/8" BELOW THE SURFACE OF THE PAVEMENT ON THE LOWEST SIDE OF THE MANHOLE.
 7. TOP OF BOX ELEVATIONS GIVEN FOR CDDOT TYPE R INLETS REFER TO THE COUNTY STANDARD DETAIL FOR CORRESPONDING DESIGN ELEVATIONS.

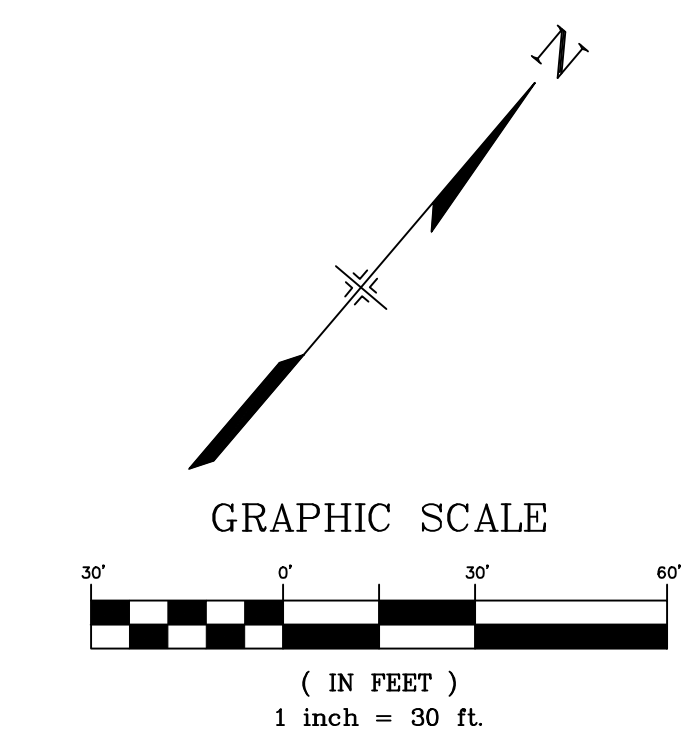

FILE LOCATION: S:\CIRCLE K HWY 24 & MERIDIAN\DWG\PLAN\SETS\OFF-SITE\CDSD01.DWG

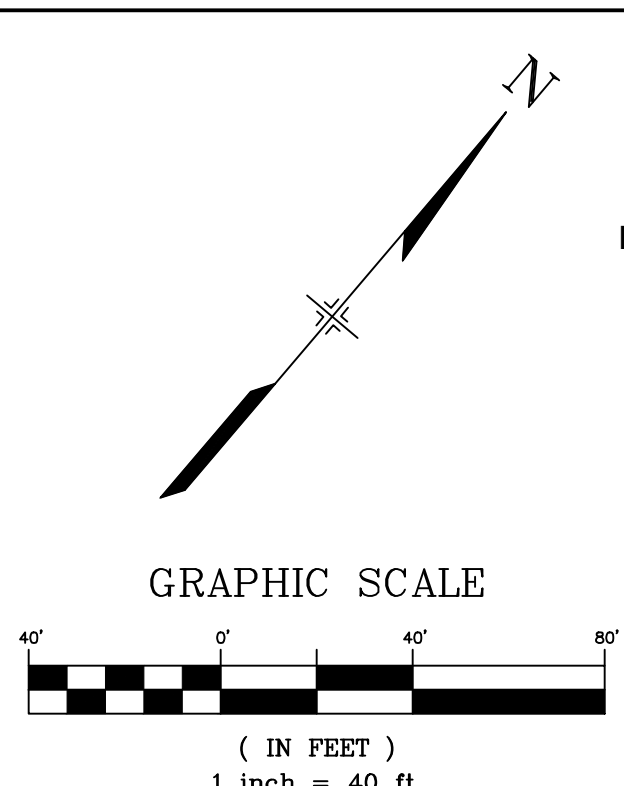
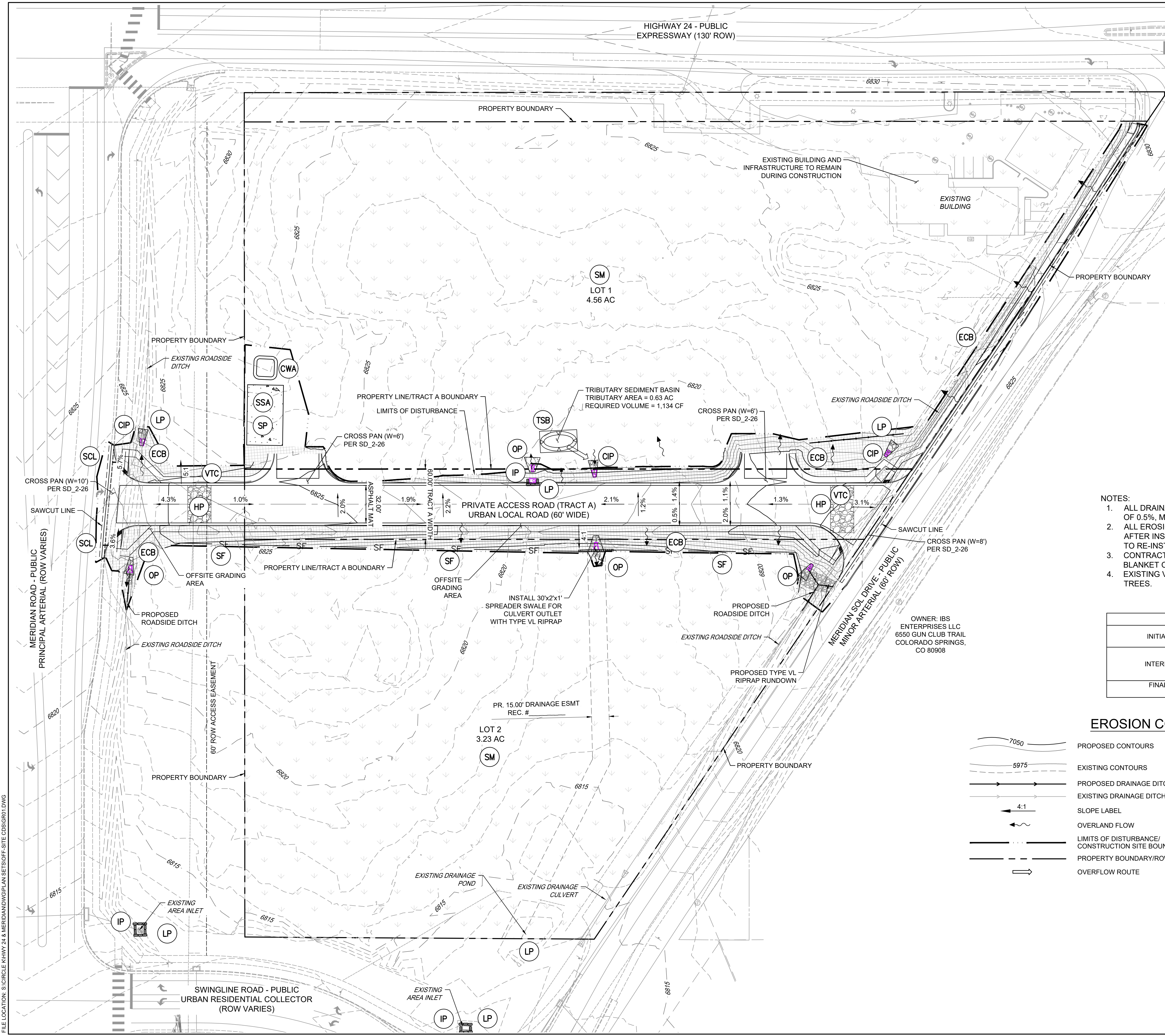

CONSULTANTS:
Matrix
 2435 RESEARCH PARKWAY, SUITE 300
 COLORADO SPRINGS, CO 80920
 PHONE: (719) 575-0100

LAND DEVELOPMENT
 CONSULTANTS, LLC
 950 S. CHERRY ST., SUITE 512
 DENVER, CO 80246

OWNER/DEVELOPER:
CIRCLE K
 ROCKY MOUNTAINS DIVISION
 5500 S QUEBEC STREET, SUITE 100
 GREENWOOD VILLAGE, CO 80111
 PHONE: (720) 758-6223

SEAL

 FOR AND ON BEHALF OF MATRIX DESIGN GROUP, INC
 CONTRACTOR IS RESPONSIBLE FOR OBTAINING THE MOST RECENT PROJECT CONSTRUCTION DOCUMENTS. MATRIX DESIGN GROUP IS NOT RESPONSIBLE FOR CHANGES, ALTERATIONS, OR USE OF CONSTRUCTION DOCUMENTS PRIOR TO JURISDICTIONAL APPROVAL.

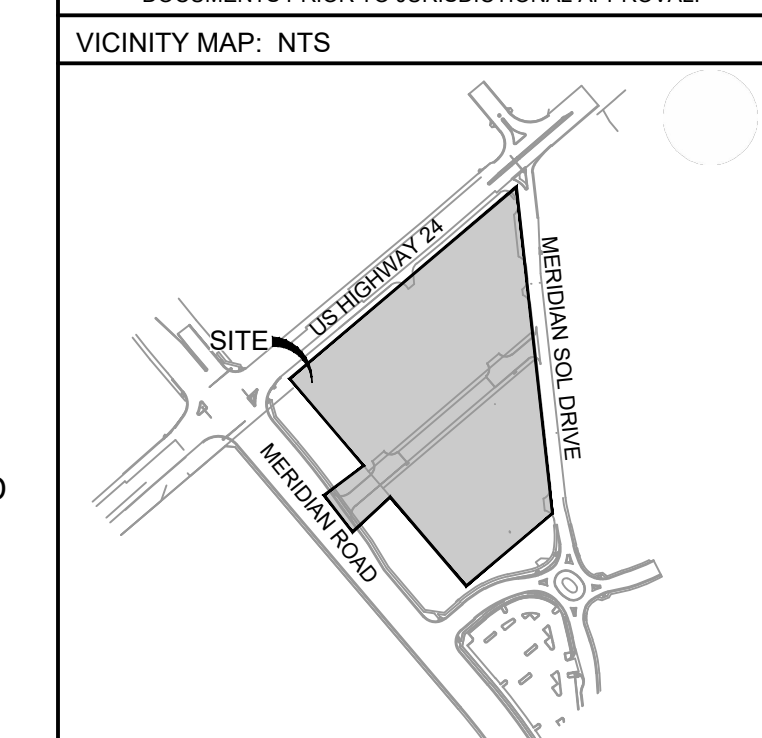

- NOTES:
- ALL DRAINAGE SWALES SHALL HAVE A MINIMUM LONGITUDINAL SLOPE OF 0.5%, MINIMUM 1.5' DEPTH, AND MAXIMUM 3:1 SIDE SLOPES.
 - ALL EROSION CONTROL BLANKET SHALL BE INSPECTED 24-MONTHS AFTER INSTALLATION. EROSION CONTROL BLANKET MAY BE REQUIRED TO RE-INSTALLED PER MANUFACTURER SPECIFICATIONS.
 - CONTRACTOR TO USE SLOPE TRACKING OR EROSION CONTROL BLANKET ON SLOPES 3:1 OR GREATER.
 - EXISTING VEGETATION CONSISTS OF NATIVE GRASSES AND SPARSE TREES.

BMP SEQUENCING	
INITIAL	SILT FENCE, VEHICLE TRACKING, TEMP SEDIMENT BASIN
INTERIM	TEMPORARY STOCKPILE, CONCRETE WASHOUT, SEDIMENT CONTROL LOGS, CULVERT INLET AND OUTLET PROTECTION, INLET PROTECTION, STOCKPILES, STAGING AREA
FINAL	EROSION CONTROL BLANKETS, SEEDING & MULCHING

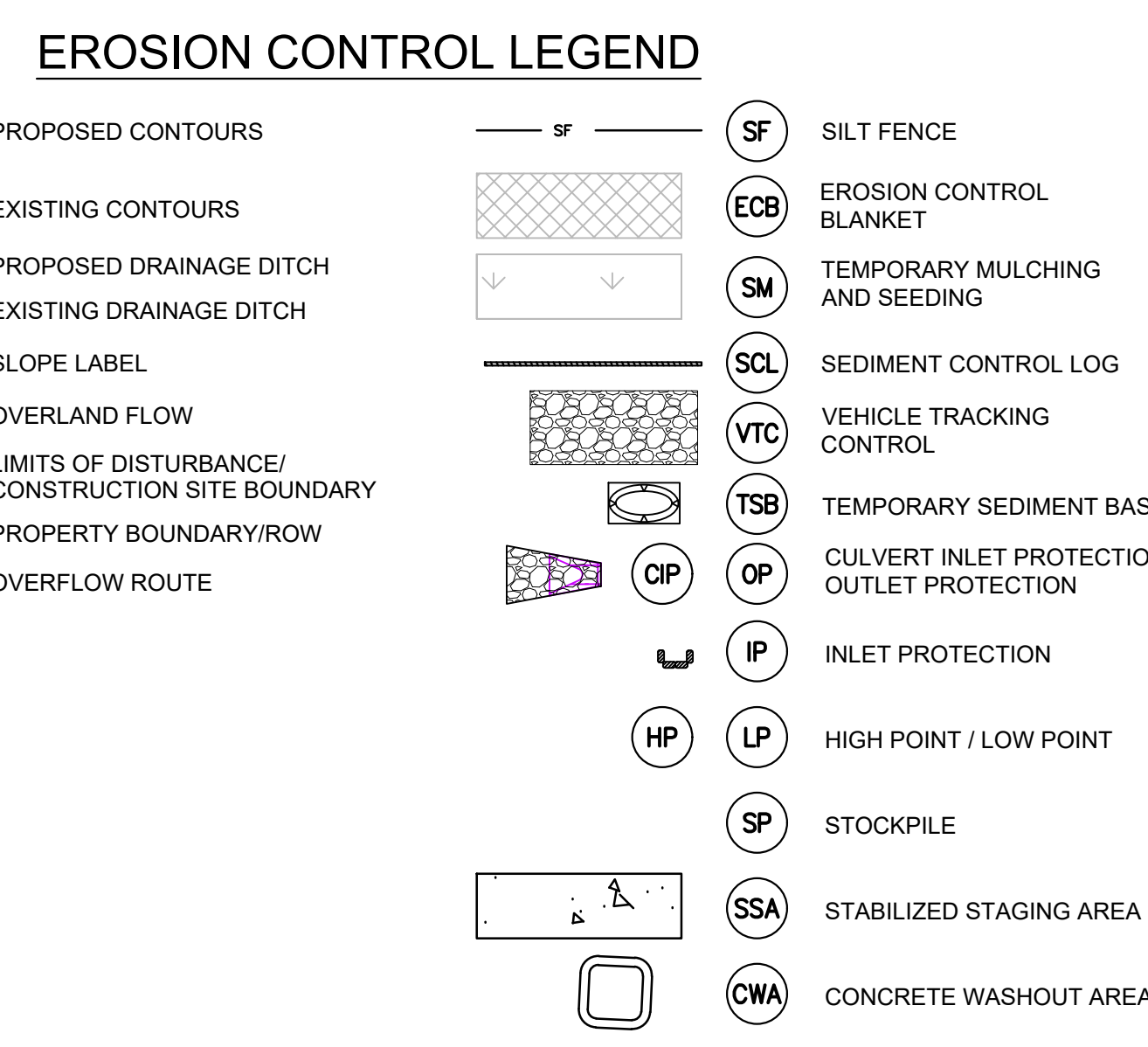

PROJECT:
CIRCLE K STORES INC.
 FINAL PLAT OFFSITE CDS
 CIRCLE K - US24 & MERIDIAN FALCON, CO

REVISION HISTORY:

NO.	DATE	DESCRIPTION	BY

DRAWING INFORMATION:
 PROJECT NO: 21.1207.037
 DRAWN BY: RPD
 CHECKED BY: NMS
 DESIGNED BY: NMS

GRADING & EROSION CONTROL PLAN

SHEET 11 OF 14
GEC01

ISSUE DATE: JANUARY 2023

FILE LOCATION: S:\CIRCLE K HWY 24 & MERIDIAN\PLAN SETS\OFF-SITE CDS\GEC01.DWG

PCD FILING NO.: VR-22-03



Know what's below. Call before you dig.

CONSULTANTS:



2435 RESEARCH PARKWAY, SUITE 300 COLORADO SPRINGS, CO 80920 PHONE: (719) 575-0100



LAND DEVELOPMENT CONSULTANTS, LLC

950 S. CHERRY ST., SUITE 512 DENVER, CO 80246

OWNER/DEVELOPER:



ROCKY MOUNTAINS DIVISION 5500 S QUEBEC STREET, SUITE 100 GREENWOOD VILLAGE, CO 80111 PHONE: (720) 758-8223

SEAL

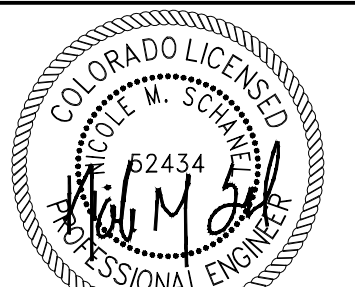

FOR AND ON BEHALF OF MATRIX DESIGN GROUP, INC CONTRACTOR IS RESPONSIBLE FOR OBTAINING THE MOST RECENT PROJECT CONSTRUCTION DOCUMENTS. MATRIX DESIGN GROUP IS NOT RESPONSIBLE FOR CHANGES, ALTERATIONS, OR USE OF CONSTRUCTION DOCUMENTS PRIOR TO JURISDICTIONAL APPROVAL.

VICINITY MAP: NTS

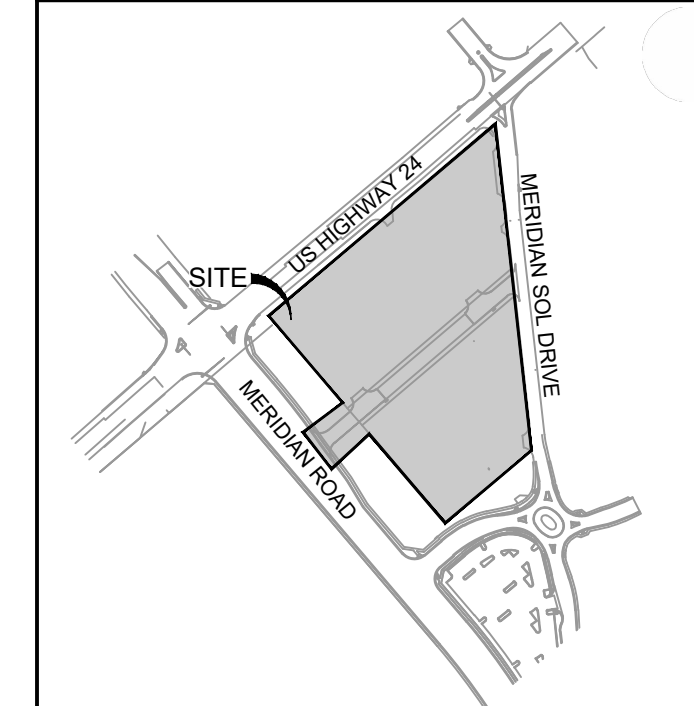

PROJECT:

CIRCLE K STORES INC.

FINAL PLAT OFFSITE CDS

CIRCLE K - US24 & MERIDIAN FALCON, CO

REVISION HISTORY:

Table with 4 columns: NO., DATE, DESCRIPTION, BY

DRAWING INFORMATION:

PROJECT NO.: 21.1207.037

DRAWN BY: RPD

CHECKED BY: NMS

DESIGNED BY: NMS

SHEET TITLE:

EROSION CONTROL NOTES

SHEET 12 OF 14 ECN01

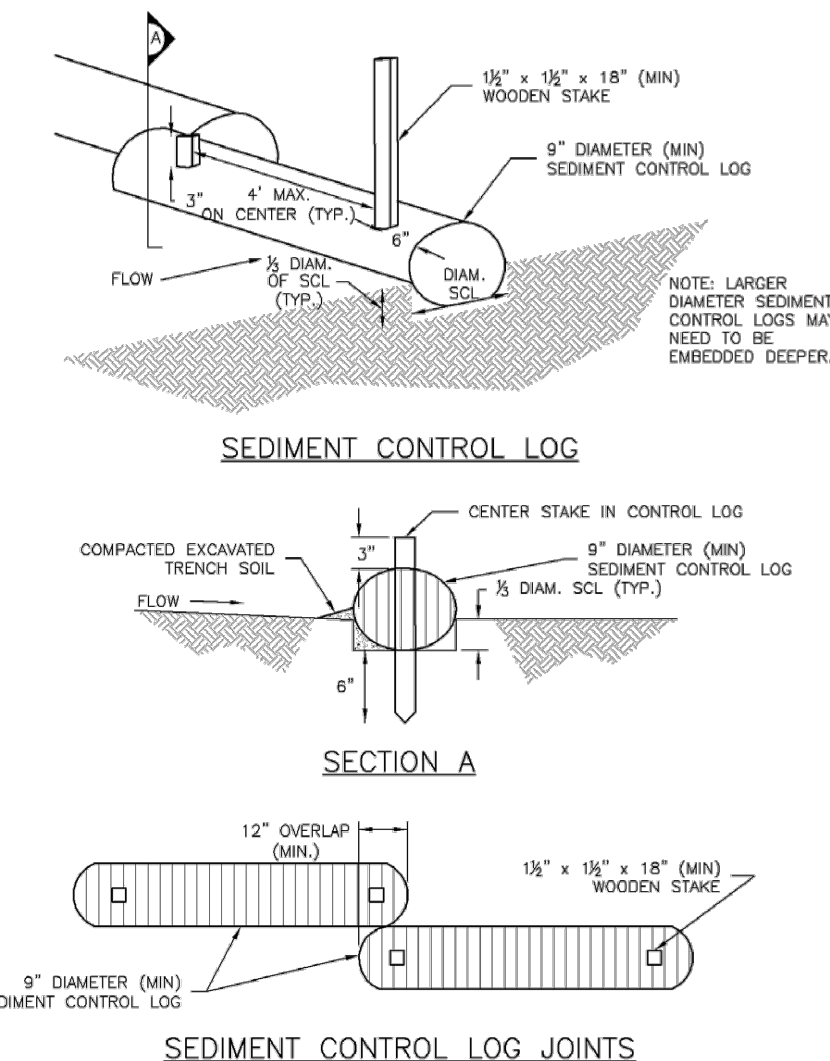

- INSTALLATION NOTES: 1. SEE PLAN VIEW FOR LOCATION AND LENGTH OF SEDIMENT CONTROL LOGS. 2. SEDIMENT CONTROL LOGS THAT ACT AS PERIMETER CONTROL SHALL BE INSTALLED PRIOR TO ANY UPGRADE... MAINTENANCE NOTES: 1. INSPECT BMPs EACH WORKDAY, AND MAINTAIN THEM IN EFFECTIVE OPERATING CONDITION...

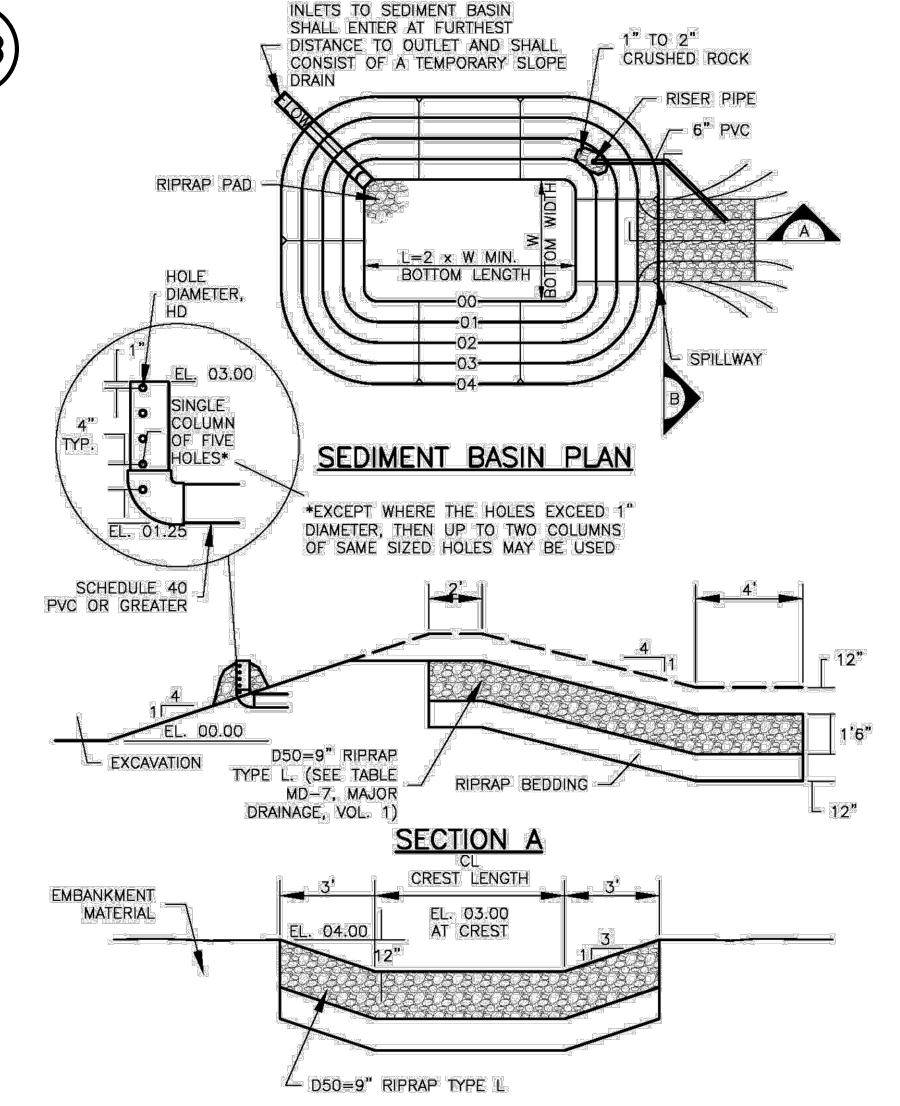
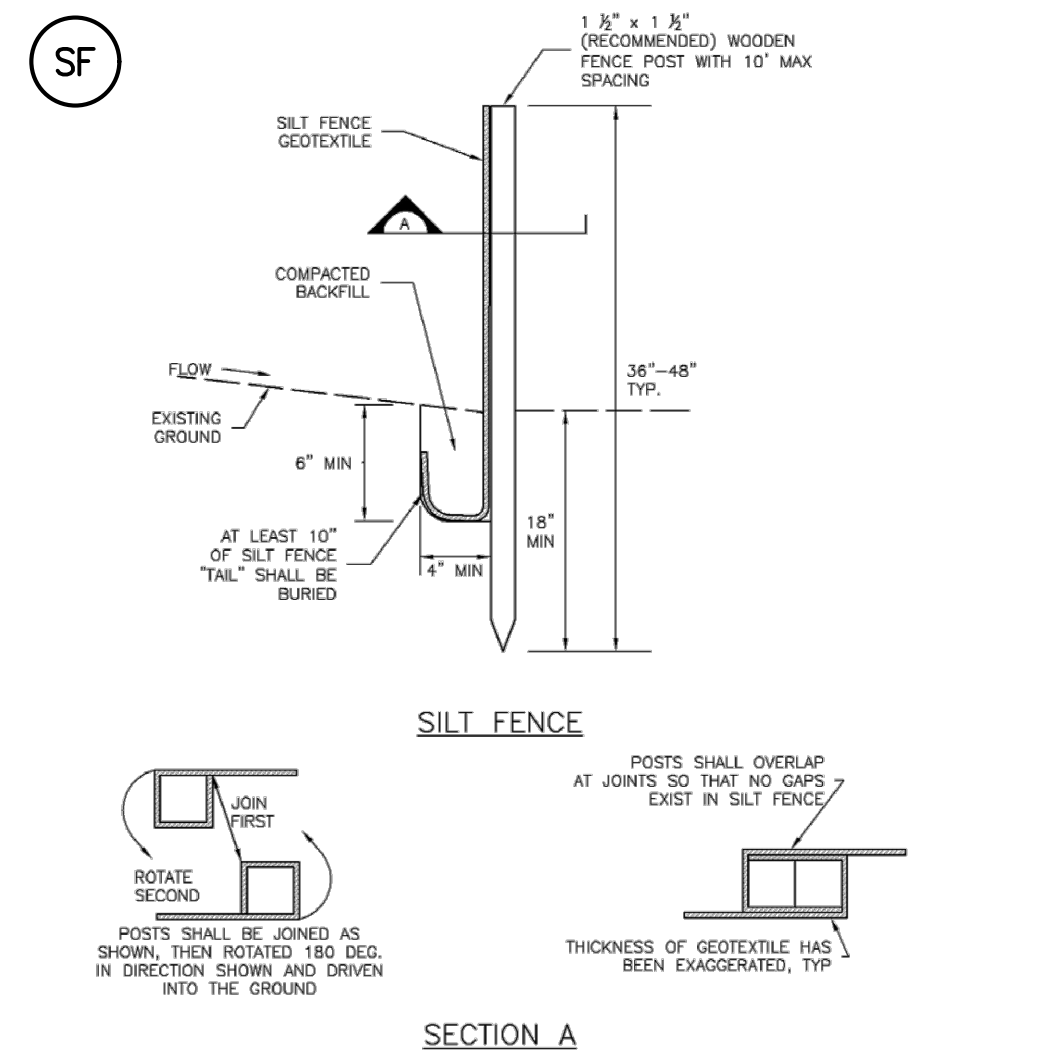
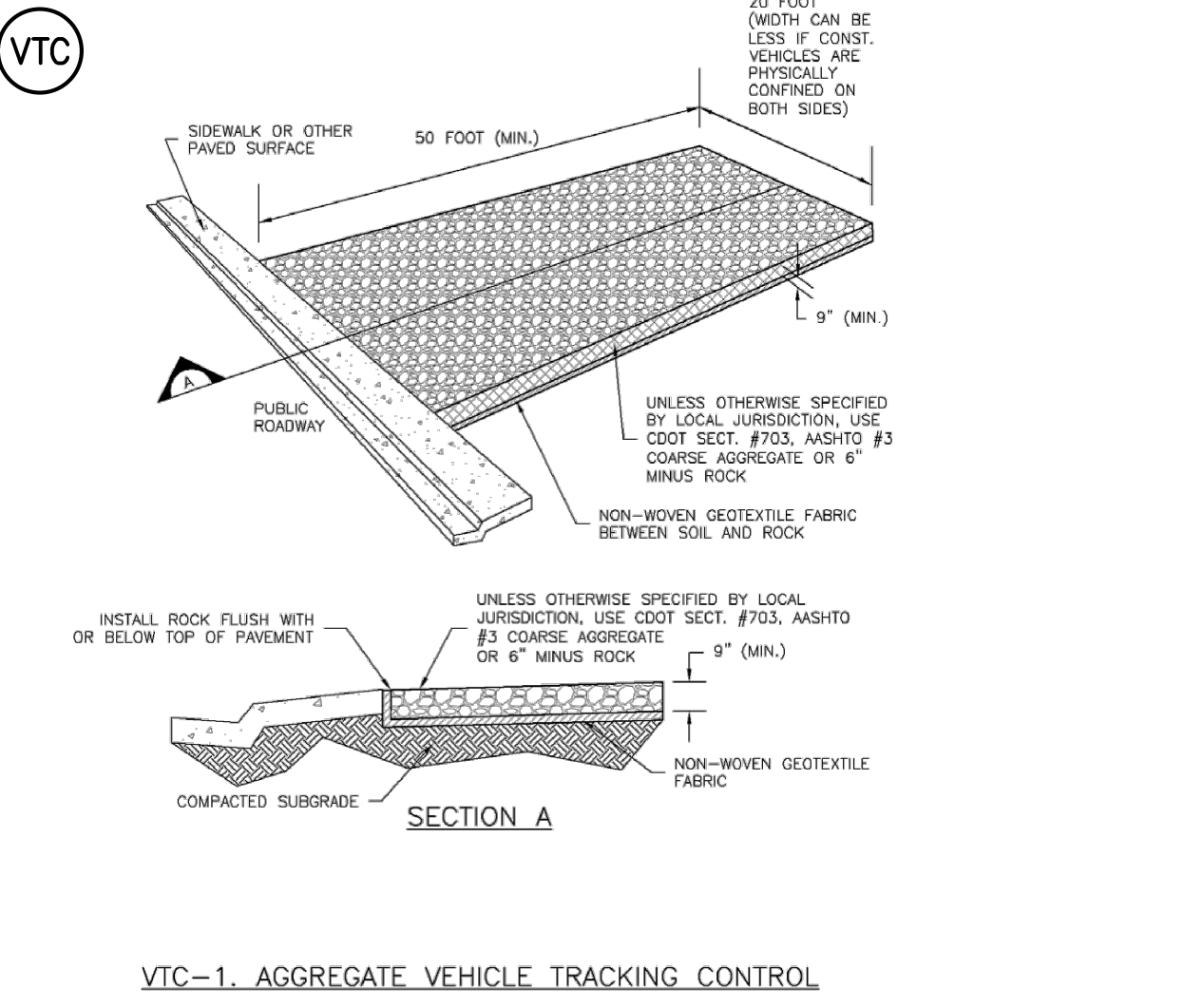

Table SB-1 SIZING INFORMATION FOR STANDARD SEDIMENT BASIN with columns for Upstream Drainage area, Basin Bottom Width, Spillway Crest Length, and Hole Diameter

- SEDIMENT BASIN INSTALLATION NOTES: 1. SEE PLAN VIEW FOR: - LOCATION OF SEDIMENT BASIN. - TYPE OF BASIN (STANDARD BASIN OR NONSTANDARD BASIN). 2. FOR STANDARD BASIN, BOTTOM DIMENSION MAY BE MODIFIED AS LONG AS BOTTOM AREA IS NOT REDUCED...



- SILT FENCE INSTALLATION NOTES: 1. SILT FENCE MUST BE PLACED AWAY FROM THE TOE OF THE SLOPE TO ALLOW FOR WATER PONDING. SILT FENCE AT TOP OF A SLOPE SHOULD BE INSTALLED IN A FLAT LOCATION AT LEAST SEVERAL FEET (2-6 FT) FROM THE TOE... SILT FENCE MAINTENANCE NOTES: 1. INSPECT BMPs EACH WORKDAY, AND MAINTAIN THEM IN EFFECTIVE OPERATING CONDITION...



- INSTALLATION NOTES: 1. SEE PLAN VIEW FOR: - LOCATION OF CONSTRUCTION ENTRANCE/EXIT. - TYPE OF CONSTRUCTION ENTRANCE/EXIT WITH/WITHOUT WHEEL WASH, CONSTRUCTION MAT OR TRIM. 2. CONSTRUCTION MAT OR TRIM STABILIZED CONSTRUCTION ENTRANCES ARE ONLY TO BE USED ON SHORT DURATION PROJECTS... MAINTENANCE NOTES: 1. INSPECT BMPs EACH WORKDAY, AND MAINTAIN THEM IN EFFECTIVE OPERATING CONDITION...

Table 14-10. Recommended Seed Mix for Transition Areas with columns for Common Name, Scientific Name, Growth Season, Growth Form, Seeds/Lb, Lbs PLS/Acre Drilled, Lbs PLS/Acre Broadcast or Hydroseeded

- SEED MIX NOTES: A MIXTURE DEVELOPED FOR ELEVATIONS 3,000 TO 8,000 FEET TO PROVIDE NATURAL COVER UNDER DRYLAND CONDITIONS. CHARACTERISTICS: GROWS 30-60 INCHES WITH AVERAGE RAINFALL. SEEDING RATE: BROADCAST: 20-25 LBS/ACRE DRILLED: 15-20 LBS/ACRE OVERSEEDING BROADCAST: 10-15 LBS/ACRE DRILLED: 5-10 LBS/ACRE MIX CONTAINS: KIND AND VARIETY: PURE GERM ORIGIN

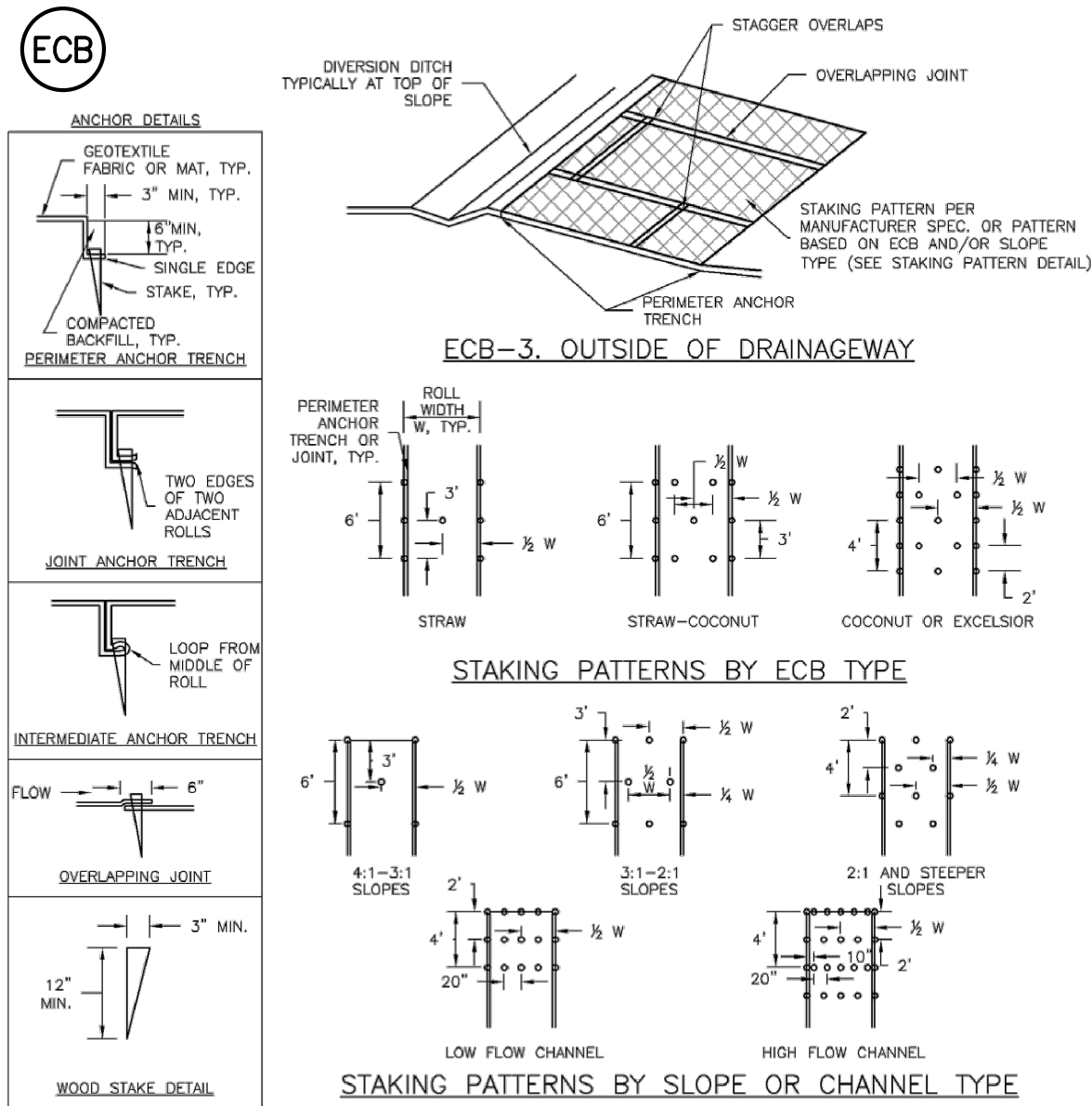

TYPE	COCONUT CONTENT	STRAW CONTENT	EXCELSIOR CONTENT	RECOMMENDED NETTING **
STRAW *	-	100%	-	DOUBLE/NATURAL
STRAW-COCONUT	30% MIN	70% MAX	-	DOUBLE/NATURAL
COCONUT	100%	-	-	DOUBLE/NATURAL
EXCELSIOR	-	-	100%	DOUBLE/NATURAL

* STRAW ECBs MAY ONLY BE USED OUTSIDE OF STREAMS AND DRAINAGE CHANNELS.
 ** ALTERNATE NETTING MAY BE ACCEPTABLE IN SOME JURISDICTIONS.

EROSION CONTROL BLANKET

- INSTALLATION NOTES:**
- SEE PLAN VIEW FOR:
 - LOCATION OF ECB.
 - TYPE OF ECB (STRAW, STRAW-COCONUT, COCONUT, EXCELSIOR).
 - AREA, A, IN SQUARE YARDS OF EACH TYPE OF ECB.
 - 100% NATURAL AND BIODEGRADABLE MATERIALS ARE PREFERRED FOR RECPs. ALTHOUGH SOME JURISDICTIONS MAY ALLOW OTHER MATERIALS IN SOME APPLICATIONS.
 - IN AREAS WHERE ECBs ARE SHOWN ON THE PLANS, THE PERMITTEE SHALL PLACE TOPSOIL AND PERFORM FINAL GRADING, SURFACE PREPARATION, AND SEEDING AND MULCHING. SUBGRADE SHALL BE SMOOTH AND MOIST PRIOR TO ECB INSTALLATION AND THE ECB SHALL BE IN FULL CONTACT WITH SUBGRADE. NO GAPS OR VOIDS SHALL EXIST UNDER THE BLANKET.
 - PERIMETER ANCHOR TRENCH SHALL BE USED ALONG THE OUTSIDE PERIMETER OF ALL BLANKET AREAS.
 - JOINT ANCHOR TRENCH SHALL BE USED TO JOIN ROLLS OF ECBs TOGETHER (LONGITUDINALLY AND TRANSVERSELY) FOR ALL ECBs EXCEPT STRAW WHICH MAY USE AN OVERLAPPING JOINT.
 - INTERMEDIATE ANCHOR TRENCH SHALL BE USED AT SPACING OF ONE-HALF ROLL LENGTH FOR COCONUT AND EXCELSIOR ECBs.
 - OVERLAPPING JOINT DETAIL SHALL BE USED TO JOIN ROLLS OF ECBs TOGETHER FOR ECBs ON SLOPES.
 - MATERIAL SPECIFICATIONS OF ECBs SHALL CONFORM TO TABLE ECB-1.
 - ANY AREAS OF SEEDING AND MULCHING DISTURBED IN THE PROCESS OF INSTALLING ECBs SHALL BE RESEEDED AND MULCHED.
 - DETAILS ON DESIGN PLAND FOR MAJOR DRAINAGEWAY STABILIZATION WILL GOVERN IF DIFFERENT FROM THOSE SHOWN HERE.
- MAINTENANCE NOTES:**
- INSPECT BMPs EACH WORKDAY, AND MAINTAIN THEM IN EFFECTIVE OPERATING CONDITION. MAINTENANCE OF BMPs SHOULD BE PROACTIVE, NOT REACTIVE. INSPECT BMPs AS SOON AS POSSIBLE (AND ALWAYS WITHIN 24 HOURS) FOLLOWING A STORM THAT CAUSES SURFACE EROSION, AND PERFORM NECESSARY MAINTENANCE.
 - FREQUENT OBSERVATIONS AND MAINTENANCE ARE NECESSARY TO MAINTAIN BMPs IN EFFECTIVE OPERATING CONDITION. INSPECTIONS AND CORRECTIVE MEASURES SHOULD BE DOCUMENTED THOROUGHLY.
 - WHERE BMPs HAVE FAILED, REPAIR OR REPLACEMENT SHOULD BE INITIATED UPON DISCOVERY OF THE FAILURE.
 - ECBs SHALL BE LEFT IN PLACE TO EVENTUALLY BIODEGRADE, UNLESS REQUESTED TO BE REMOVED BY THE LOCAL JURISDICTION.
 - ANY ECB PULLED OUT, TORN, OR OTHERWISE DAMAGED SHALL BE REPAIRED OR REINSTALLED. ANY SUBGRADE AREAS BELOW THE GEOTEXTILE THAT HAVE ERODED TO CREATED A VOID UNDER THE BLANKET, OR THAT REMAIN DEVOID OF GRASS SHALL BE REPAIRED, RESEEDED AND MULCHED AND THE ECB REINSTALLED.

Figure EC-6
Rolled Erosion Control Product
Urban Drainage and Flood Control District
Urban Storm Drainage Criteria Manual Volume 3

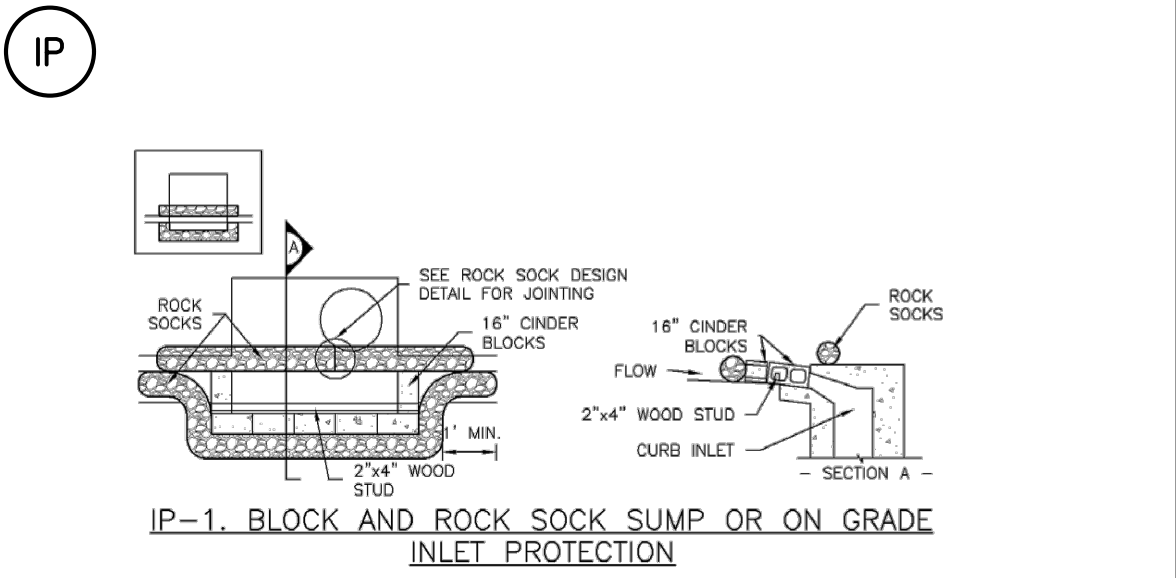

TEMPORARY INLET PROTECTION IP-1

- INSTALLATION NOTES:**
- SEE ROCK SOCK DESIGN DETAIL FOR INSTALLATION REQUIREMENTS.
 - CONCRETE "CINDER" BLOCKS SHALL BE LAID ON THEIR SIDES AROUND THE INLET IN A SINGLE ROW, ABUTTING ONE ANOTHER WITH THE OPEN END FACING AWAY FROM THE CURB.
 - GRAVEL BAGS SHALL BE PLACED AROUND CONCRETE BLOCKS, CLOSELY ABUTTING ONE ANOTHER AND JOINED TOGETHER IN ACCORDANCE WITH ROCK SOCK DESIGN DETAIL.

Figure IP-1
Temporary Inlet Protection
Urban Drainage and Flood Control District

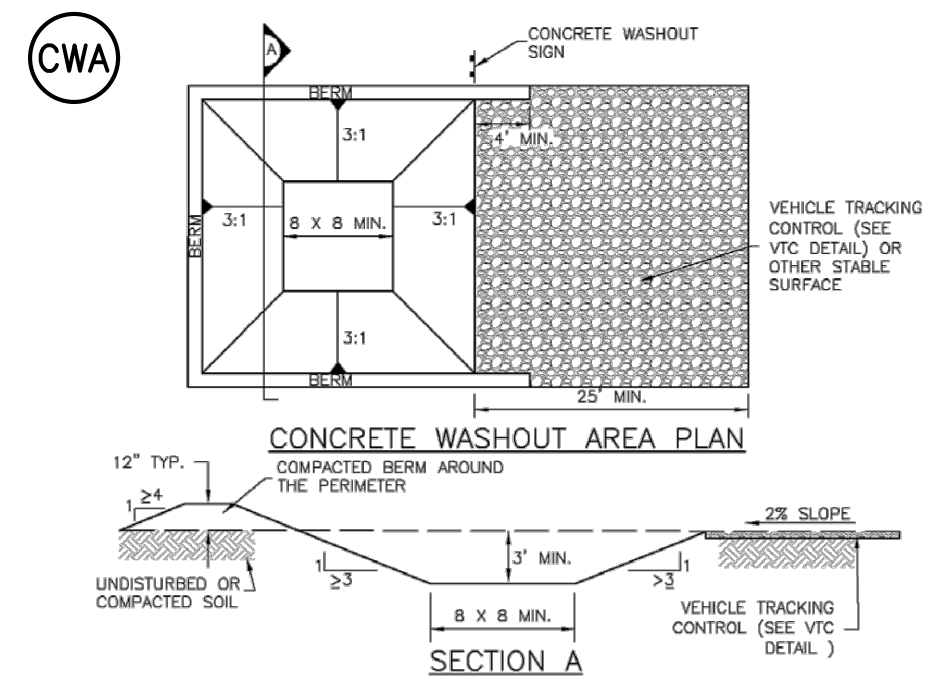

CONCRETE WASHOUT AREA

CWA INSTALLATION NOTES:

- SEE PLAN VIEW FOR:
 - CWA INSTALLATION LOCATION.
- DO NOT LOCATE AN UNLINED CWA WITHIN 400' OF ANY NATURAL DRAINAGE PATHWAY OR WATER BODY. DO NOT LOCATE WITHIN 1000' OF ANY WELLS OR DRINKING WATER SOURCES. IF SITE CONSTRAINTS MAKE THIS INFEASIBLE, OR IF HIGHLY PERMEABLE SOILS EXIST ON SITE, THE CWA MUST BE INSTALLED WITH AN IMPERMEABLE LINER (16 MIL MIN. THICKNESS) OR SURFACE STORAGE ALTERNATIVES USING PREFABRICATED CONCRETE WASHOUT DEVICES OR A LINED ABOVE GROUND STORAGE AREA SHOULD BE USED.
- THE CWA SHALL BE INSTALLED PRIOR TO CONCRETE PLACEMENT ON SITE.
- THE CWA SHALL INCLUDE A FLAT SUBSURFACE PIT THAT IS AT LEAST 9' BY 6'. SLOPES LEADING OUT OF THE SUBSURFACE PIT SHALL BE 3:1 OR FLATTER. THE PIT SHALL BE AT LEAST 3' DEEP.
- BERM SURROUNDING SIDES AND BACK OF THE CWA SHALL HAVE A MINIMUM HEIGHT OF 1'.
- VEHICLE TRACKING PAD SHALL BE SLOPED 2% TOWARDS THE CWA.
- SIGNS SHALL BE PLACED AT THE CONSTRUCTION ENTRANCE, AT THE CWA, AND ELSEWHERE AS NECESSARY TO CLEARLY INDICATE THE LOCATION OF THE CWA TO OPERATORS OF CONCRETE TRUCKS AND PUMP RIGS.
- USE EXCAVATED MATERIAL FOR PERIMETER BERM CONSTRUCTION.

Figure CWA-3
Concrete Washout Area
Urban Drainage and Flood Control District
Urban Storm Drainage Criteria Manual Volume 3

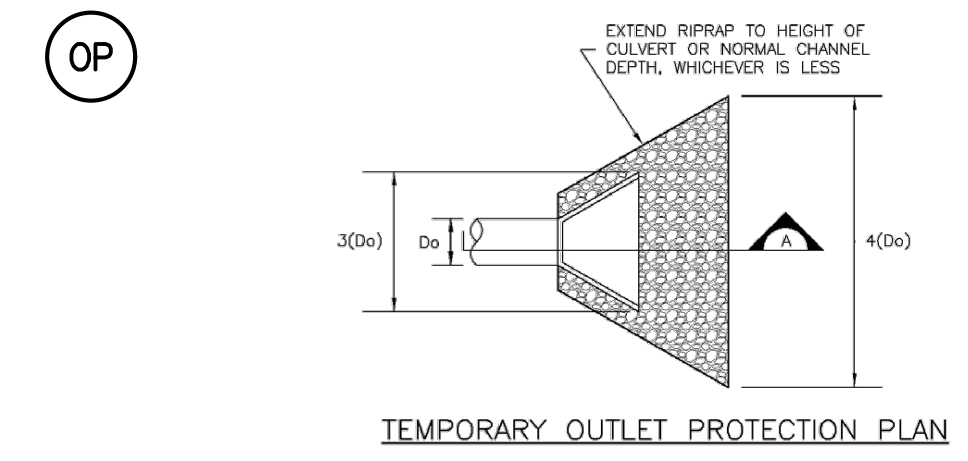

TEMPORARY OUTLET PROTECTION

PIPE DIAMETER, Dp (INCHES)	DISCHARGE, Q (CFS)	APRON LENGTH, Lo (FT)	RRAP D50 DIAMETER, MIN (INCHES)
8	2.5	5	4
	5	10	6
12	10	10	6
	20	13	8
18	10	10	6
	20	13	8
	30	23	12
	40	26	16
24	30	16	9
	40	26	12
	60	30	16

OP-1. TEMPORARY OUTLET PROTECTION

TEMPORARY OUTLET PROTECTION

- INSTALLATION NOTES:**
- SEE PLAN VIEW FOR:
 - LOCATION OF OUTLET PROTECTION.
 - DIMENSIONS OF OUTLET PROTECTION.
 - DETAIL IS INTENDED FOR PIPES WITH SLOPE ≤ 10%. ADDITIONAL EVALUATION OF RRAP SIZING AND OUTLET PROTECTION DIMENSIONS REQUIRED FOR STEEPER SLOPES.
 - TEMPORARY OUTLET PROTECTION INFORMATION IS FOR OUTLETS INTENDED TO BE UTILIZED LESS THAN 2 YEARS.
- MAINTENANCE NOTES:**
- INSPECT BMPs EACH WORKDAY, AND MAINTAIN THEM IN EFFECTIVE OPERATING CONDITION. MAINTENANCE OF BMPs SHOULD BE PROACTIVE, NOT REACTIVE. INSPECT BMPs AS SOON AS POSSIBLE (AND ALWAYS WITHIN 24 HOURS) FOLLOWING A STORM THAT CAUSES SURFACE EROSION, AND PERFORM NECESSARY MAINTENANCE.
 - FREQUENT OBSERVATIONS AND MAINTENANCE ARE NECESSARY TO MAINTAIN BMPs IN EFFECTIVE OPERATING CONDITION. INSPECTIONS AND CORRECTIVE MEASURES SHOULD BE DOCUMENTED THOROUGHLY.
 - WHERE BMPs HAVE FAILED, REPAIR OR REPLACEMENT SHOULD BE INITIATED UPON DISCOVERY OF THE FAILURE.

Figure EC-8
Temporary Outlet Protection
Urban Drainage and Flood Control District
Urban Storm Drainage Criteria Manual Volume 3

Stockpile Management (SP)

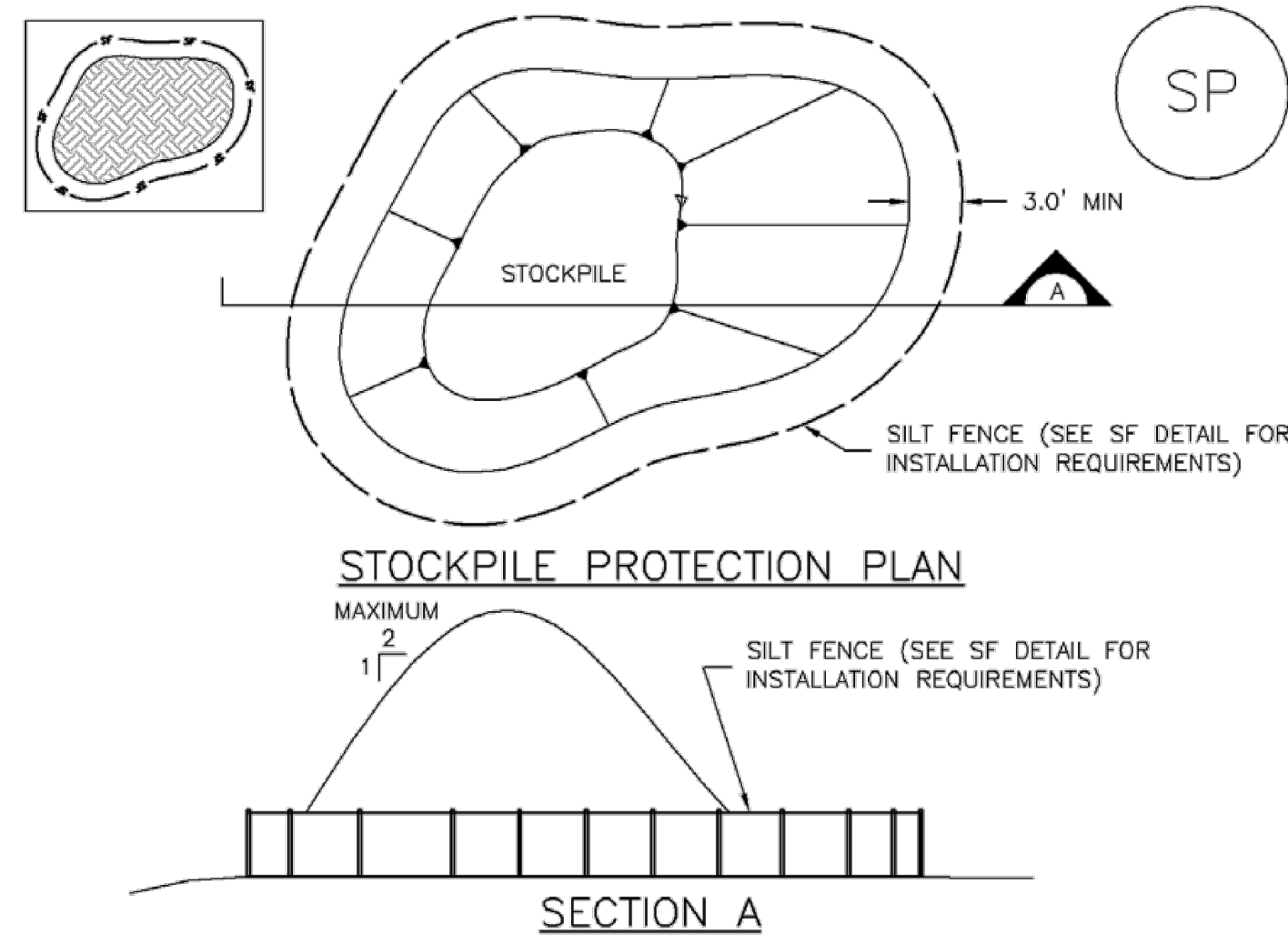

SP-1. STOCKPILE PROTECTION

- STOCKPILE PROTECTION INSTALLATION NOTES**
- SEE PLAN VIEW FOR:
 - LOCATION OF STOCKPILES.
 - TYPE OF STOCKPILE PROTECTION.
 - INSTALL PERIMETER CONTROLS IN ACCORDANCE WITH THEIR RESPECTIVE DESIGN DETAILS. SILT FENCE IS SHOWN IN THE STOCKPILE PROTECTION DETAILS; HOWEVER, OTHER TYPES OF PERIMETER CONTROLS INCLUDING SEDIMENT CONTROL LOGS OR ROCK SOCKS MAY BE SUITABLE IN SOME CIRCUMSTANCES. CONSIDERATIONS FOR DETERMINING THE APPROPRIATE TYPE OF PERIMETER CONTROL FOR A STOCKPILE INCLUDE WHETHER THE STOCKPILE IS LOCATED ON A PERVIOUS OR IMPERVIOUS SURFACE, THE RELATIVE HEIGHTS OF THE PERIMETER CONTROL AND STOCKPILE, THE ABILITY OF THE PERIMETER CONTROL TO CONTAIN THE STOCKPILE WITHOUT FAILING IN THE EVENT THAT MATERIAL FROM THE STOCKPILE SHIFTS OR SLUMPS AGAINST THE PERIMETER, AND OTHER FACTORS.
 - STABILIZE THE STOCKPILE SURFACE WITH SURFACE ROUGHENING, TEMPORARY SEEDING AND MULCHING, EROSION CONTROL BLANKETS, OR SOIL BINDERS. SOILS STOCKPILED FOR AN EXTENDED PERIOD (TYPICALLY FOR MORE THAN 60 DAYS) SHOULD BE SEEDED AND MULCHED WITH A TEMPORARY GRASS COVER ONCE THE STOCKPILE IS PLACED (TYPICALLY WITHIN 14 DAYS). USE OF MULCH ONLY OR A SOIL BINDER IS ACCEPTABLE IF THE STOCKPILE WILL BE IN PLACE FOR A MORE LIMITED TIME PERIOD (TYPICALLY 30-60 DAYS).
 - FOR TEMPORARY STOCKPILES ON THE INTERIOR PORTION OF A CONSTRUCTION SITE, WHERE OTHER DOWNGRADE CONTROLS, INCLUDING PERIMETER CONTROL, ARE IN PLACE, STOCKPILE PERIMETER CONTROLS MAY NOT BE REQUIRED.

MM-2

Stabilized Staging Area (SSA)

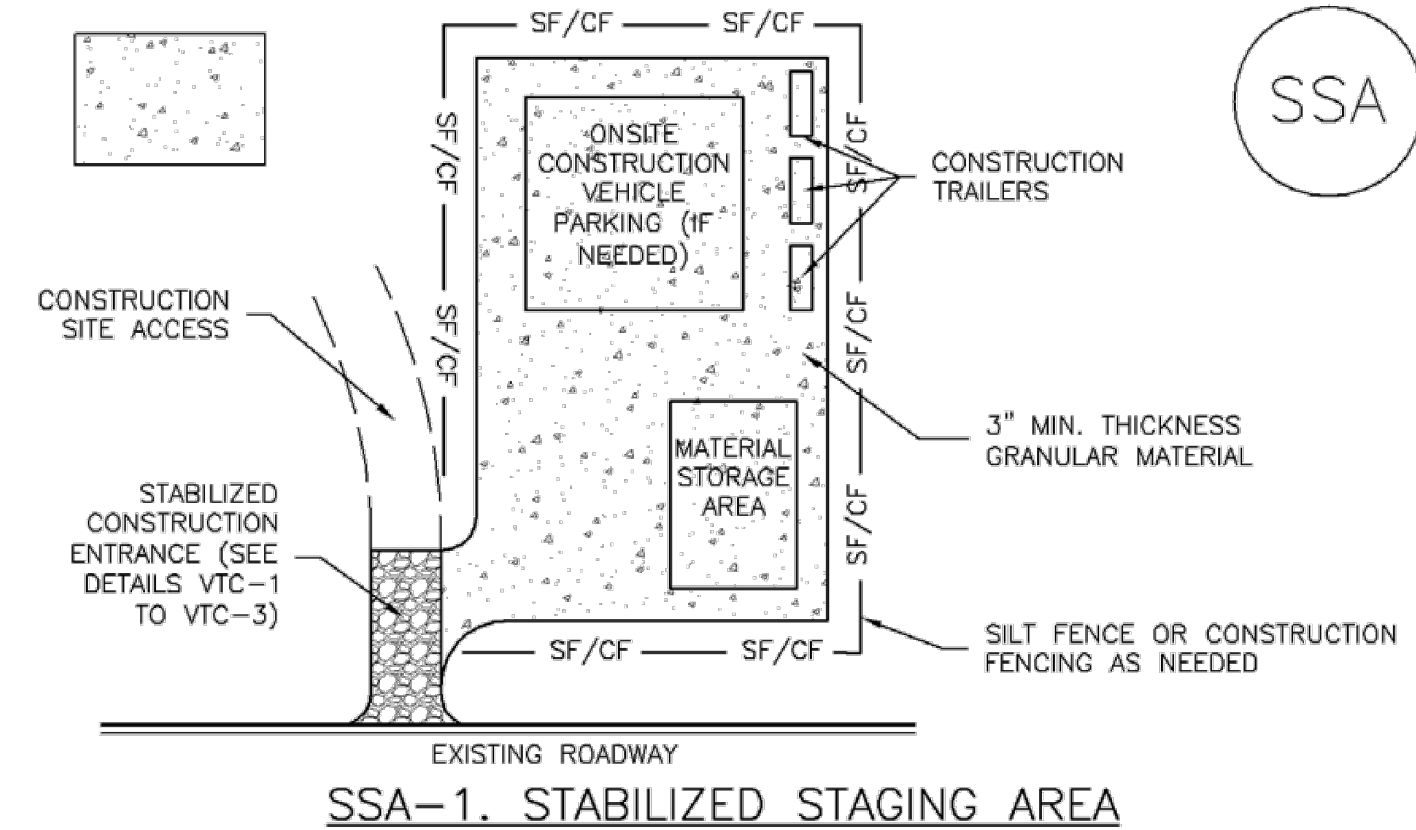

SSA-1. STABILIZED STAGING AREA

- STABILIZED STAGING AREA INSTALLATION NOTES**
- SEE PLAN VIEW FOR:
 - LOCATION OF STAGING AREA(S).
 - CONTRACTOR MAY ADJUST LOCATION AND SIZE OF STAGING AREA WITH APPROVAL FROM THE LOCAL JURISDICTION.
 - STABILIZED STAGING AREA SHOULD BE APPROPRIATE FOR THE NEEDS OF THE SITE. OVERSIZING RESULTS IN A LARGER AREA TO STABILIZE FOLLOWING CONSTRUCTION.
 - STAGING AREA SHALL BE STABILIZED PRIOR TO OTHER OPERATIONS ON THE SITE.
 - THE STABILIZED STAGING AREA SHALL CONSIST OF A MINIMUM 3" THICK GRANULAR MATERIAL.
 - UNLESS OTHERWISE SPECIFIED BY LOCAL JURISDICTION, ROCK SHALL CONSIST OF DOT SECT. #703, AASHTO #3 COARSE AGGREGATE OR 6" (MINUS) ROCK.
 - ADDITIONAL PERIMETER BMPs MAY BE REQUIRED INCLUDING BUT NOT LIMITED TO SILT FENCE AND CONSTRUCTION FENCING.
- STABILIZED STAGING AREA MAINTENANCE NOTES**
- INSPECT BMPs EACH WORKDAY, AND MAINTAIN THEM IN EFFECTIVE OPERATING CONDITION. MAINTENANCE OF BMPs SHOULD BE PROACTIVE, NOT REACTIVE. INSPECT BMPs AS SOON AS POSSIBLE (AND ALWAYS WITHIN 24 HOURS) FOLLOWING A STORM THAT CAUSES SURFACE EROSION, AND PERFORM NECESSARY MAINTENANCE.
 - FREQUENT OBSERVATIONS AND MAINTENANCE ARE NECESSARY TO MAINTAIN BMPs IN EFFECTIVE OPERATING CONDITION. INSPECTIONS AND CORRECTIVE MEASURES SHOULD BE DOCUMENTED THOROUGHLY.
 - WHERE BMPs HAVE FAILED, REPAIR OR REPLACEMENT SHOULD BE INITIATED UPON DISCOVERY OF THE FAILURE.
 - ROCK SHALL BE REAPPLIED OR REGRADED AS NECESSARY IF RUTTING OCCURS OR UNDERLYING SUBGRADE BECOMES EXPOSED.

SM-6

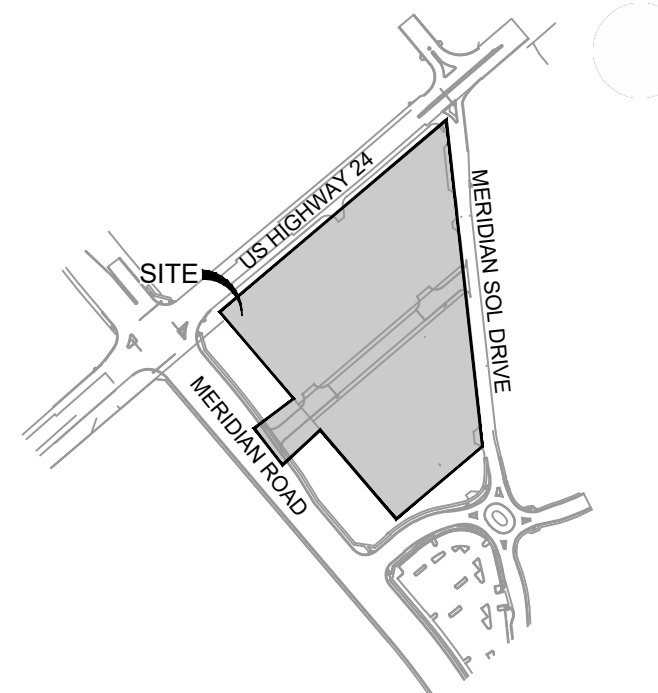

PROJECT:
CIRCLE K STORES INC.
 FINAL PLAT OFFSITE CDS
 CIRCLE K - US24 & MERIDIAN FALCON, CO

REVISION HISTORY:

NO.	DATE	DESCRIPTION	BY

DRAWING INFORMATION:

PROJECT NO: 21.1207.037
 DRAWN BY: RPD
 CHECKED BY: NMS
 DESIGNED BY: NMS
 SHEET TITLE:

EROSION CONTROL NOTES

SHEET 13 OF 14
ECN02



CONSULTANTS:
Matrix
 2435 RESEARCH PARKWAY, SUITE 300
 COLORADO SPRINGS, CO 80920
 PHONE: (719) 575-0100

LAND DEVELOPMENT CONSULTANTS, LLC
 950 S. CHERRY ST., SUITE 512
 DENVER, CO 80246



ROCKY MOUNTAINS DIVISION
 5500 S QUEBEC STREET, SUITE 100
 GREENWOOD VILLAGE, CO 80111
 PHONE: (720) 758-6223

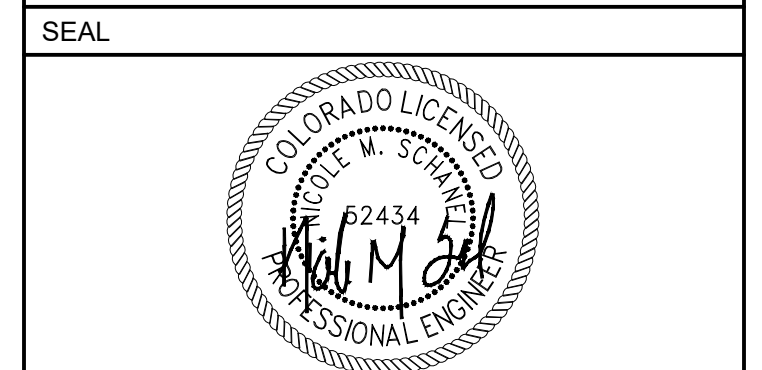

FOR AND ON BEHALF OF MATRIX DESIGN GROUP, INC
 CONTRACTOR IS RESPONSIBLE FOR OBTAINING THE MOST RECENT PROJECT CONSTRUCTION DOCUMENTS. MATRIX DESIGN GROUP IS NOT RESPONSIBLE FOR CHANGES, ALTERATIONS, OR USE OF CONSTRUCTION DOCUMENTS PRIOR TO JURISDICTIONAL APPROVAL.

VICINITY MAP: NTS



CONSULTANTS:

 2435 RESEARCH PARKWAY, SUITE
 300 COLORADO SPRINGS, CO 80920
 PHONE: (719) 575-0100

LAND DEVELOPMENT
 CONSULTANTS, LLC
 950 S. CHERRY ST., SUITE 512
 DENVER, CO 80246

OWNER/DEVELOPER:

 ROCKY MOUNTAINS DIVISION
 5500 S QUEBEC STREET, SUITE 100
 GREENWOOD VILLAGE, CO 80111
 PHONE: (720) 758-6223

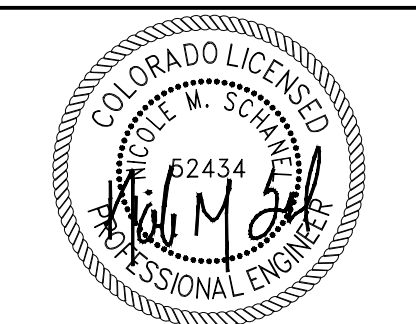
SEAL

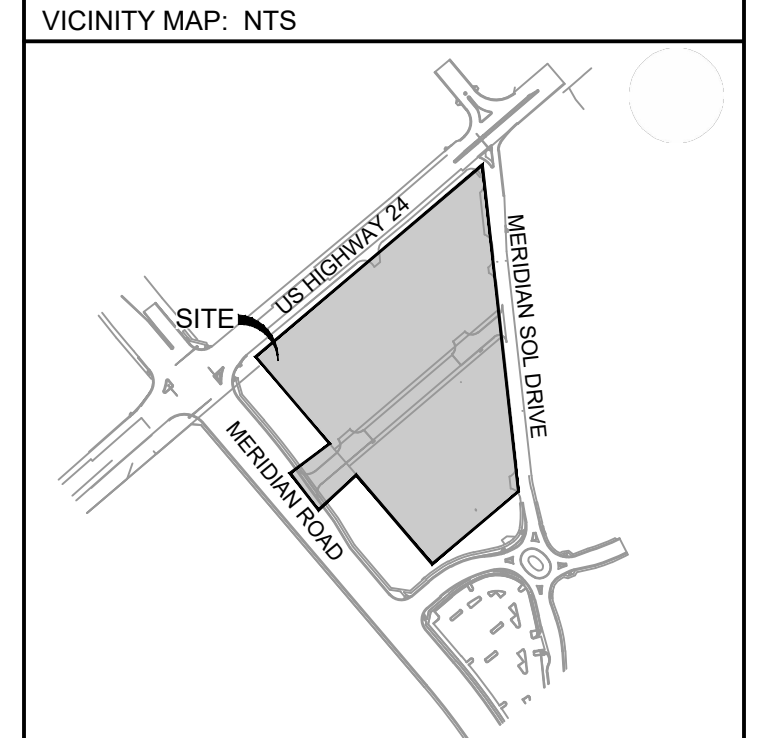
 FOR AND ON BEHALF OF MATRIX DESIGN GROUP, INC
 CONTRACTOR IS RESPONSIBLE FOR OBTAINING THE
 MOST RECENT PROJECT CONSTRUCTION DOCUMENTS.
 MATRIX DESIGN GROUP IS NOT RESPONSIBLE FOR
 CHANGES, ALTERATIONS, OR USE OF CONSTRUCTION
 DOCUMENTS PRIOR TO JURISDICTIONAL APPROVAL.



PROJECT:
CIRCLE K STORES INC.
 FINAL PLAT OFFSITE CDS
 CIRCLE K - US24 & MERIDIAN
 FALCON, CO

REVISION HISTORY:



NO.	DATE	DESCRIPTION	BY

DRAWING INFORMATION:
 PROJECT NO: 21.1207.037
 DRAWN BY: RPD
 CHECKED BY: NMS
 DESIGNED BY: NMS
 SHEET TITLE:

SIGNING & STRIPING PLAN

SHEET 14 OF 14
 SN01

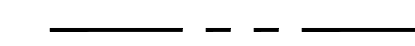
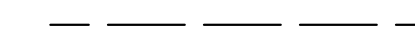
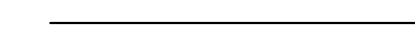
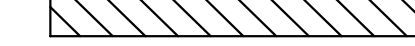
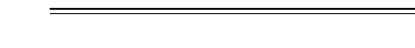
SITE LEGEND

-  PROPERTY BOUNDARY LINE
-  SETBACK LINE
-  EASEMENT BOUNDARY LINE
-  PROPOSED STRIPING
-  PROPOSED CONCRETE CURB & GUTTER
-  SITE DISTANCE

NOTES:
 TRAFFIC CONTROL DEVICES SHOWN REPRESENT THE
 INTERMEDIATE SIGNING AND STRIPING FOR ALL INTERNAL
 ROADS. IT WILL BE THE CONTRACTORS RESPONSIBILITY TO
 ADJUST TRAFFIC CONTROL DEVICES AS NEEDED TO
 ACCOMMODATE CHANGES IN TRAFFIC MOVEMENTS.

ALL SIGN PLACEMENT SHOULD BE ACCORDING TO EL PASO
 COUNTY TRAFFIC ENGINEERING SIGNAGE AND PAVEMENT
 MARKINGS GUIDELINES (LATEST EDITION) AND THE MANUAL ON
 UNIFORM TRAFFIC CONTROL DEVICES (LATEST EDITION).

