



MVE, INC.
ENGINEERS SURVEYORS

1903 kelaray street, suite 200
colorado springs, co 80909
719.635.5736

Preliminary & Final Drainage Report

Sanctuary of Peace Residential Community

**PUD Development,
Preliminary Plan and
Final Plat**

Project Number 61087

PCD Proj # PUDSP-019-002

April 28, 2020

Copyright © MVE, Inc., 2020

Preliminary & Final Drainage Report

for

Sanctuary of Peace Residential Community
PUD Development, Preliminary Plan and Final Plat

Project No. 61087

April 28, 2020

prepared for

Benet Hill Monastery of Colorado Springs, Inc.
3190 Benet Lane
Colorado Springs, CO 80921
719.355.1639

prepared by

MVE, Inc.
1903 Lelaray Street, Suite 200
Colorado Springs, CO 80909
719.635.5736

Copyright © MVE, Inc., 2020

61087 SOP Final Drainage Report-full.odt

Statements and Acknowledgments

Engineer's Statement

This attached Drainage plan and report were prepared by under my direct supervision and are correct to the best of my knowledge and belief. Said report and plan has been prepared in accordance with the criteria established by the County for drainage reports and said report is in conformity with the applicable master plan of the drainage basin. I accept responsibility for any liability caused by any negligent acts, errors or omissions on my part in preparing this report.



David R. Gorman, P.E. Colorado No. 31672
For and on Behalf of Benet Hill Monastery of Colorado Springs, Inc. 7/22/20



7/22/20
Date

Developer's Statement

Benet Hill Monastery of Colorado Springs, Inc., the owner/developer have read and will comply with all the requirements specified in this drainage report and plan.



Vincent Crowder
Benet Hill Monastery of Colorado Springs, Inc.
3190 Benet Lane
Colorado Springs, CO 80921

7.22.20
Date

El Paso County

Filed in accordance with the requirements of the Drainage Criteria Manual, Volumes 1 and 2, El Paso County Engineering Criteria Manual and Land Development Code as amended.

Jennifer Irvine, P.E. , County Engineer / ECM Administrator
El Paso County

APPROVED
Engineering Department

10/08/2020 7:19:51 AM

dsdnijkamp

**EPC Planning & Community
Development Department**

Final Drainage Report
Sanctuary of Peace Filing No. 1
Project No. 61087

PURPOSE

This is the Final Drainage Report is for the Sanctuary of Peace Residential Community PUD Development and Preliminary Plan, and the Final Plat of Sanctuary of Peace Filing No. 1. The purpose of this Final Drainage Report is to identify on-site and off-site drainage patterns, storm sewer, culvert and inlet locations, areas tributary to the site and to safely route developed storm water to adequate outfalls.

SUMMARY OF DATA

- Black Squirrel Creek Drainage Basin Planning Study – URS Consultants – January, 1989
- Smith Creek Drainage Basin Planning Study – JR Engineering – August, 2002
- Drainage Letter for Benet Hill Monastery/Ministry Center – Bradley B. Bean, PE – August 17, 2007
- City of Colorado Springs “Drainage Criteria Manual, Volume 1”, May, 2014.
- City of Colorado Springs and El Paso County “Drainage Criteria Manual, Volume 2” May, 2014.
- Soil Survey for El Paso County, Colorado, U.S. Department of Agriculture, Soil Conservation Service.
- “Flood Insurance Studies for Colorado Springs and El Paso County, Colorado”, prepared by the Federal Emergency Management Agency (FEMA), December 7, 2018.

Except for the previously mentioned drainage reports, no other drainage reports were reviewed during the course of preparing this drainage report.

GENERAL LOCATION & DESCRIPTION

The Sanctuary of Peace Residential Community contains 49.58+/- acres of land. Said Community is situate in South Half of Section 27, Township 11 South, Range 66 West of the 6th Principal Meridian within the County of El Paso, and the State of Colorado. The El Paso County Assessor Schedule Number is 7103001034 for the parcel of land and the address is 15760 State Highway 83.

The Sanctuary of Peace Residential Community is bounded on the east by State Highway 83, on the north by Benet Lane, on the west by Black Forest Park subdivision, and on the south by 10 & 20+/- acres parcels of un-platted land.

The Sanctuary of Peace Residential Community is located in two Major Drainage Basins and they are Black Squirrel Creek and Smith Creek of which are both Fee Basins.

FLOODPLAIN STATEMENT

The Sanctuary of Peace Residential Community is not located in a designated floodplain as denoted on the Flood Insurance Rate Map (FIRM), map number 08041C0295G, effective date December 7, 2018. The FIRM is included in the **Appendix** for readers reference.

SOILS

The SCS Soils Map describes the soils as consisting of Kettle gravelly loamy sand (map unit 41), which is Hydrologic group "B". A soils Map and soils information is included for readers reference.

PROPOSED DEVELOPMENT

The proposed PUD Development Plan Preliminary Plan is composed of 27 Lots and 6 Tracts with drives, parking, landscaping, and three (3) Water Quality Sand Filter Basins. The proposed development is composed of 27 lots, clustered on 2.93 acres with 0.77 acres of paved roads, totaling 3.70 acres which is to be developed out of the parcel's total acreage of 49.58 acres. This Final Drainage report assumes a developed state for the entire development.

DRAINAGE CRITERIA

This Final Drainage Report for the Sanctuary of Peace Residential Community has been prepared according to the report guidelines presented in the *El Paso County Drainage Criteria Manual* (DCM). The County has also adopted portions of the City of Colorado Springs Drainage Criteria Volumes 1 and 2, especially concerning the calculation rainfall runoff rates. The hydrologic analysis is based on a collection of data from the DCM, the NRCS Web Soil Survey, topographic mapping and property boundary information provided by Polaris Land Surveying, Inc. and proposed plan layout, grading, and drainage system layout developed by M.V.E., Inc. All proposed drainage facilities are approximate in size and may vary with actual layout and design.

For this final drainage report the Rational Method as described in the *City of Colorado Springs Drainage Criteria Manual* has been used for all Storm Runoff calculations, as the development and all sub-basins are less than 130 acres in area. "Colorado Springs Rainfall Intensity Duration Frequency" curves, Figure 6-5 in the DCM, was used to obtain the design rainfall values; a copy is included in the **Appendix**. The "Overland (Initial) Flow Equation" (Eq. 6-8) in the DCM, and Manning's equation with estimated depths were used in time of concentration calculations. "Runoff Coefficients for Rational Method", Table 6-6 in the

DCM, was utilized as a guide in estimating runoff coefficient and Percent Impervious values; a copy is included in the **Appendix**. Peak runoff discharges were calculated for each drainage sub-basin for both the 5-year storm event and the 100-year storm event with the Rational Method formula, (Eq. 6-5) in the DCM.

DRAINAGE CHARACTERISTICS AND EXISTING DRAINAGE FACILITIES

The Development Plan for this site is proposing a clustered residential community, with drives, parking, landscaping, and three (3) Water Quality Sand Filter Basins. The site site of 49.58 acres, will have 27 Lots clustered on 3.90 acres with drives, parking, and existing trees & vegetation. The remainder of lands will be undisturbed except for placement of the Onsite Wastewater Treatment Systems (OWTS) and the placement of the three (3) Water Quality Basins.

The following descriptions describe how the existing and developed storm water flows are and will be handled. This Final Drainage Report for the PUD Development, Preliminary Plan and Final Plat submittal is hereby provided for the proposed Development. The existing and proposed Drainage Maps have been included in this report showing the improvements on the Sanctuary of Peace Residential Community for the readers reference.

Hydraulic Grade Line calculations are required, but will be provided with the construction drawings.

EXISTING DRAINAGE BASIN DESCRIPTIONS

An Existing Drainage Map is included for readers reference and an analysis has been included in the report. The site is within two Major Drainage Basins split by a ridge traversing the site from north to south near the middle of the site. The Black Squirrel Major Basin composes the eastern portion of the site and contains 19.73 acres. The Smith Creek Basin composes the western portion of the site and contains 29.85 acres.

The off-site drainage Basins OS A, OS B, and OS C storm water flows are calculated as existing flows and will remain as existing as there is no proposed development in these off-site Basins proposed by this plan.

Refer to he included Existing Drainage Map for direction and quantity of these existing storm water flows.

DEVELOPED DRAINAGE BASIN DESCRIPTIONS

A Proposed Drainage Map is included for readers reference and an analysis has been included in the report. The 49.58 acre site has been split into nine (9) on-site Drainage Basins with 7 of these Drainage Basins being located in the Black Squirrel Major Basin and 2 of these Drainage Basins being located in the Smith Creek Major Basin. The off-site Drainage Basins number three (3) with one (1) of these Drainage Basins being located in the Black Squirrel Major Basin and two (2) of these Drainage Basins being located in the Smith Creek Major Basin.

The clustered residential community portion to be developed of 3.90 acres is a very small portion of the total site and includes five (5) on site drainage basins.

The off-site drainage Basins OS A, OS B, and OS C storm water flows are not changed from their existing characteristics and do not affect our site as delineated in the above Existing Drainage Basin Descriptions.

Design Point P1 has existing storm water flows from drainage Basins OS A, OSB, & A2 and will flow overland & under Benet Lane continuing overland and exiting the Subdivision at the west side close to the southwest corner at a rate of $Q_5 = 34.8$ cfs and $Q_{100} = 230.2$ cfs as it has historically done.

Design Point PP2 has proposed storm water flows from Drainage Basin A1 and will flow overland across the private drive and overland through 8 lots to the proposed Full Spectrum Sand Filter Basin (FSSFB) - A1 at DP2. Storm Drainage flows will be treated and released at a rate of $Q_5 = 0.1$ cfs and $Q_{100} = 3.1$ cfs from the FSSFB - A1. The capacity of said FSSFB - A1 will be not less than 5,991+/- cubic feet (CF) to accept the required Water Quality Capture Volume for the developed Drainage Basin A1. Excess flows above the Water Quality Capture Volume requirement will over flow to a proposed 22' wide emergency spillway from the pond. These flows will pass through a 20' wide & 1' deep concrete weir onto a rip rap emergency spillway. These flows combine on site with Drainage Basin OS A, OS B, & A2 as shown on the included Proposed Drainage Map (Detail) for readers reference. The combined rate of flow is $Q_5 = 34.8$ cfs and $Q_{100} = 229.9$ cfs and exit the site at Design Point DP1.

Design Point DP3 has proposed storm water flows from Drainage Basin C2 and will flow overland across the private driveway and overland through 3 lots to the proposed Full Spectrum Sand Filter Basin (FSSFB) - C2 at DP3. Storm Drainage flows will be treated and released at a rate of $Q_5 = 0.0$ cfs and $Q_{100} = 1.1$ cfs from the FSSFB - C2. The capacity of said FSSFB - C2 will be not less than 1,783+/- cubic feet (CF) to accept the required Water Quality Capture Volume for the developed Drainage Basin C2. Excess flows above the Water Quality Capture Volume requirement will over flow to a proposed 12' wide emergency spillway from the pond. These flows will pass through a 10' wide & 1' deep concrete weir onto a rip rap emergency spillway. These flows combine on site with Drainage Basin C3 as shown on the included Proposed Drainage Map (Detail) for readers reference. The combined rate of flow is $Q_5 = 0.4$ cfs and $Q_{100} = 4.2$ cfs and exit the site at Design Point DP4.

Design Point DP5 has proposed storm water flows from Drainage Basin C4 and will flow overland exiting the subdivision along the southern boundary line at a rate of $Q_5 = 0.2$ cfs and $Q_{100} = 1.6$ cfs. This area remains in its existing state of forested land.

Design Point DP6 has proposed storm water flows from Drainage Basin C1 and will flow overland & through 8 lots, under the private drive via an 18" RC Pipe combining with the overland flow through 5 lots to the proposed Full Spectrum Sand Filter Basin (FSSFB) - C1 at PP6. Storm Drainage flows will be treated and released at a rate of $Q_5 = 0.1$ cfs and $Q_{100} = 6.1$ cfs from the FSSFB - C1. The capacity of said FSSFB - C1 will be not less than 10,563+/- cubic feet (CF) to accept the required Water Quality Capture Volume for the developed Drainage Basin C1. Excess flows above the Water Quality Capture Volume requirement will over flow to a proposed 26' wide emergency spillway from the pond. These flows will pass through a 24' wide & 1' deep concrete weir onto a rip rap emergency

spillway. These flows combine on site with Drainage Basin C5 as shown on the included Proposed Drainage Map (Detail) for readers reference. The combined rate of flow is Q5 = 0.6 cfs and Q100 = 10.0 cfs and will exit the site at Design Point DP7.

Design Point DP8 has proposed storm water flows from Drainage Basin B1 and will flow overland to Benet Lane (private drive) and cross under said drive via an 18" RC Pipe into Basin B2. This area remains in its existing state of forested land. The rate of flow is Q5 = 0.6 cfs and Q100 = 10.0 cfs and exits at Design Point PP8.

Design Point PP9 has proposed storm water flows from Drainage Basin OS C and will flow overland to Benet Lane (private drive) and under Benet Lane via existing culverts. These storm water flows will combine with DP8 and overland flows from Basin B2. This area remains in its existing state of forested land. The rate of flow is Q5 = 24.9 cfs and Q100 = 137.2 cfs and exits the site along its southerly boundary designated as Point of Interest DP9.

WATER QUALITY

The Urban Drainage and Flood Control District provides criteria for design of a water quality pond as part of the Sand Filter design guidelines. This criteria specifies that this type of water quality pond shall be drained over a 12-hour period. The relief (grade change) of the natural gullies will allow the Water Quality Sand Filter Basin treated storm waters and storm waters to discharge at same grade.

The Full Spectrum Sand Filter Basins (are to be located on the southern and western side of the clustered housing will be constructed to collect the runoff from the developed portion of the site and treat & reduce the discharges from the site to existing levels. The Full Spectrum Sand Filter Basins will be constructed in accordance with El Paso County drainage criteria as supplemented by the accepted Urban Drainage Criteria, procedures, and methods. They will be owned and maintained by the Sanctuary of Peace Home Owners Association. These Full Spectrum Sand Filter Basins will be sited and located in the field by the Project Engineer to allow the designs to blend with the environment and limit unnecessary disturbance of land, trees, and vegetation. Once the Full Spectrum Sand Filter Basins are constructed, As- Built surveys will be conducted and a Substantial Compliance letter for the construction of them will be prepared by the Project Engineer.

EROSION CONTROL

During future construction, best management practices (BMP's) for erosion control will be employed based on the previously referenced El Paso County Drainage Criteria Manual Volume 1 & 2 and the approved Erosion Control Plan to minimize erosion from the site. The BMP's will remain in place until the site is stabilized with the new hard surfacing or landscape seeding, planting and cover materials. Also, BMP's will be utilized as deemed necessary by the contractor, engineer, owner, or County inspector and are not limited to the measures described on the Erosion Control Plan.

WATER QUALITY ENHANCEMENT BEST MANAGEMENT PRACTICES

This development will utilize the three (3) Full Spectrum Sand Filter Basins to be constructed. The Basins have been adequately sized for this purpose. Other drainage facilities in this project consist of two (2) - 18 " RC Pipes at proposed locations under the new private drive. These facilities will be private and will be maintained by the development's homeowners association. A Grading and Erosion Control Plan for the construction of the site has been prepared in accordance with the provisions of the County's Engineering Criteria Manual in conjunction with the private drive plan & profile design drawings. Placement of construction storm water BMP's will as required by the plan will limit soil erosion and deposition by storm water flowing over the site.

The El Paso County Engineering Criteria Manual (Appendix I, Section I.7.2) requires the consideration of a "Four Step Process for receiving water protection that focuses on reducing runoff volumes, treating the water quality capture volume (WQCV), stabilizing drainage-ways, and implementing long term source controls". The Four Step Process is incorporated in this project and the elements are discussed below.

- 1) Runoff Reduction Practices are employed in this project. Impervious surfaces have been reduced as much as practically possible. A significant portion of the site, 45.88 acres, which is 92% will remain as pervious well treed open space.
- 2) There are no drainage paths on the site that are required to be stabilized as they are well vegetated with no visual erosion. The Water Quality Detention Water Quality Basins will intercept flows from developed areas. Additionally, all inflow points will be stabilized by re-vegetation as incoming flows are not erosive.
- 3) The project contains no potentially hazardous uses. All developed areas drain into a proposed a Water Quality Capture Volume (WQCV) BMP.
- 4) The site is residential in nature and contains no storage of potentially harmful substances or use of potentially harmful substances. No Site Specific or Other Source Control BMP's are required.

The following cost opinion is for the construction of the required private storm water appurtenances. There are no public storm water facilities required.

DRAINAGE FACILITIES CONSTRUCTION COST ESTIMATE

Opinion of Costs – Private Storm Water Facilities

•	73 Lf	18" RC Pipe	@ \$ 65 per Lf	= \$ 4,745
•	4 Ea	18" RC Flared End	@ \$ 390 per Ea	= 1,560
•	4 Tn	Type VL Rip-Rap	@ \$ 80 per Tn	= 320
•	1187 Cy	Sand Filter Basin Constr.	@ \$ 20 per Cy	= 23,740
•	3 Ea	Sand Filter Basin Spillway	@ \$2003 per Ea	= 6,009
•	3 Ea	Sand Filter Basin Outlet Str.	@ \$1480 per Ea	= <u>4,440</u>
		Grand Total		= \$40,814

DRAINAGE, BRIDGE, AND SURCHARGE FEES

The Sanctuary of Peace Residential Community contains 49.58 acres of land. The Board of County Commissioners, County of El Paso, State of Colorado Resolution No. 99-383 allows the drainage basin fee to be based on impervious acreage. Black Squirrel Creek Basin contains 1.55 acres and Smith Creek Basin contains 0.67 acres of developed impervious acreage.

The resolution also allows a fee reduction of 25% for those portions of the development that consist entirely of 2.5 acre and larger lots. The Sanctuary of Peace Residential Community has clustered lots of below the 2.5 acre limit and therefore does not qualify.

FEE CALCULATION (2020 Fees)

Black Squirrel Drainage Basin

Drainage Fee \$8,664 / Impervious Acre @ 1.55 Acres = \$ 13,429.20

Bridge Fee \$545 / Impervious Acre @ 1.55 Acres = \$ 844.75

Smith Creek Drainage Basin

Drainage Fee \$7,780 / Impervious Acre @ 0.67 Acres = \$ 5,212.60

Bridge Fee \$1,044 / Impervious Acre @ 0.67 Acres = \$ 699.48

Grand Total Fees = \$ 20,186.03

CONCLUSION

The proposed site improvements will direct, control, and treat storm drainage runoff. The downstream drainage facilities will accept the proposed flows as described in this report. The proposed development of said Sanctuary of Peace Residential Community will not negatively impact the adjacent properties and down stream drainage facilities.

Appendices

1 General Maps and Supporting Data

Vicinity Map

Portion of Flood Insurance Rate Map

Soil Type map and Tables

Official Soil Series Descriptions

Hydrologic Soil Group Map and Tables

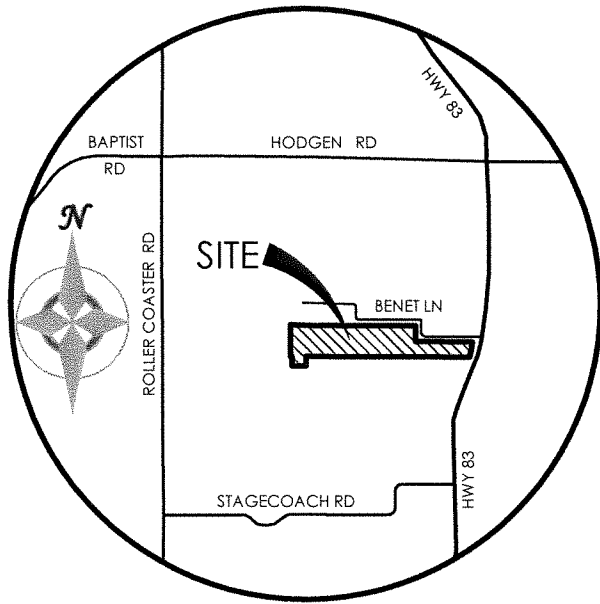

VICINITY MAP

NOT TO SCALE

National Flood Hazard Layer FIRMette



39°3'53.61"N



104°46'8.33"W

104°45'30.88"W

USGS The National Map, Orthoimagery, Data refreshed October, 2017.

39°3'25.68"N

1:6,000



Legend

SEE FIS REPORT FOR DETAILED LEGEND AND INDEX MAP FOR FIRM PANEL LAYOUT

SPECIAL FLOOD HAZARD AREAS

- Without Base Flood Elevation (BFE) Zone A, V, A99
- With BFE or Depth Zone AE, AH, AO, AP, VE, AR
- Regulatory Floodway

OTHER AREAS OF FLOOD HAZARD

- 0.2% Annual Chance Flood Hazard, Areas of 1% annual chance flood with average depth less than one foot or with drainage areas of less than one square mile Zone X
- Future Conditions 1% Annual Chance Flood Hazard Zone X
- Area with Reduced Flood Risk due to Levee. See Notes. Zone X
- Area with Flood Risk due to Levee Zone D

OTHER AREAS

- Area of Minimal Flood Hazard Zone X
- Effective LOMFRs
- Area of Undetermined Flood Hazard Zone D

GENERAL STRUCTURES

- Channel, Culvert, or Storm Sewer
- Levee, Dike, or Floodwall

OTHER FEATURES

- Cross Sections with 1% Annual Chance Water Surface Elevation
- Coastal Transect
- Base Flood Elevation Line (BFE)
- Limit of Study
- Jurisdiction Boundary
- Coastal Transect Baseline
- Profile Baseline
- Hydrographic Feature

MAP PANELS

- Digital Data Available
- No Digital Data Available
- Unmapped

The pin displayed on the map is an approximate point selected by the user and does not represent an authoritative property location.

This map complies with FEMA's standards for the use of digital flood maps if it is not void as described below. The basemap shown complies with FEMA's basemap accuracy standards.

The flood hazard information is derived directly from the authoritative NFHL web services provided by FEMA. This map was exported on 1/9/2019 at 2:51:17 PM and does not reflect changes or amendments subsequent to this date and time. The NFHL and effective information may change or become superseded by new data over time.

This map image is void if the one or more of the following map elements do not appear: basemap imagery, flood zone labels, legend, scale bar, map creation date, community identifiers, FIRM panel number, and FIRM effective date. Map images for unmapped and unmodernized areas cannot be used for regulatory purposes.

Soil Map—El Paso County Area, Colorado

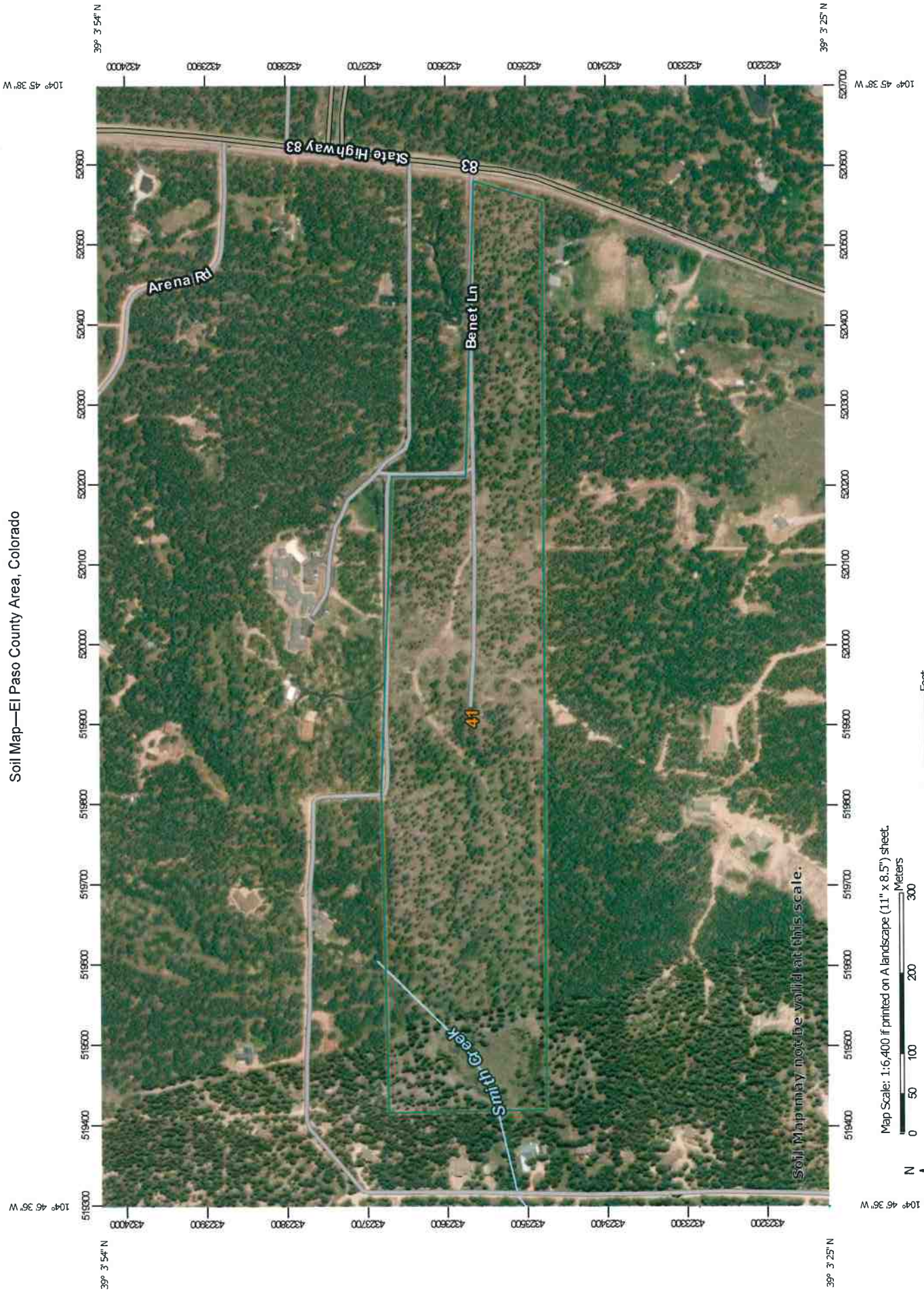

Map Scale: 1:6,400 if printed on A landscape (11" x 8.5") sheet.



Map projection: Web Mercator Corner coordinates: WGS84 Edge tics: UTM Zone 13N WGS84

MAP LEGEND

-  Area of Interest (AOI)
-  Area of Interest (AOI)
- Soils**
-  Soil Map Unit Polygons
-  Soil Map Unit Lines
-  Soil Map Unit Points
- Special Point Features**
-  Blowout
-  Borrow Pit
-  Clay Spot
-  Closed Depression
-  Gravel Pit
-  Gravelly Spot
-  Landfill
-  Lava Flow
-  Marsh or swamp
-  Mine or Quarry
-  Miscellaneous Water
-  Perennial Water
-  Rock Outcrop
-  Saline Spot
-  Sandy Spot
-  Severely Eroded Spot
-  Sinkhole
-  Slide or Slip
-  Sodic Spot
-  Spoil Area
-  Stony Spot
-  Very Stony Spot
-  Wet Spot
-  Other
-  Special Line Features
- Water Features**
-  Streams and Canals
- Transportation**
-  Rails
-  Interstate Highways
-  US Routes
-  Major Roads
-  Local Roads
- Background**
-  Aerial Photography

MAP INFORMATION

The soil surveys that comprise your AOI were mapped at 1:24,000.

Warning: Soil Map may not be valid at this scale.

Enlargement of maps beyond the scale of mapping can cause misunderstanding of the detail of mapping and accuracy of soil line placement. The maps do not show the small areas of contrasting soils that could have been shown at a more detailed scale.

Please rely on the bar scale on each map sheet for map measurements.

Source of Map: Natural Resources Conservation Service
 Web Soil Survey URL:
 Coordinate System: Web Mercator (EPSG:3857)

Maps from the Web Soil Survey are based on the Web Mercator projection, which preserves direction and shape but distorts distance and area. A projection that preserves area, such as the Albers equal-area conic projection, should be used if more accurate calculations of distance or area are required.

This product is generated from the USDA-NRCS certified data as of the version date(s) listed below.

Soil Survey Area: El Paso County Area, Colorado
 Survey Area Data: Version 16, Sep 10, 2018

Soil map units are labeled (as space allows) for map scales 1:50,000 or larger.

Date(s) aerial images were photographed: Jul 4, 2010—Oct 16, 2017

The orthophoto or other base map on which the soil lines were compiled and digitized probably differs from the background imagery displayed on these maps. As a result, some minor shifting of map unit boundaries may be evident.

Map Unit Legend

Map Unit Symbol	Map Unit Name	Acres in AOI	Percent of AOI
41	Kettle gravelly loamy sand, 8 to 40 percent slopes	47.2	100.0%
Totals for Area of Interest		47.2	100.0%

Hydrologic Soil Group—El Paso County Area, Colorado

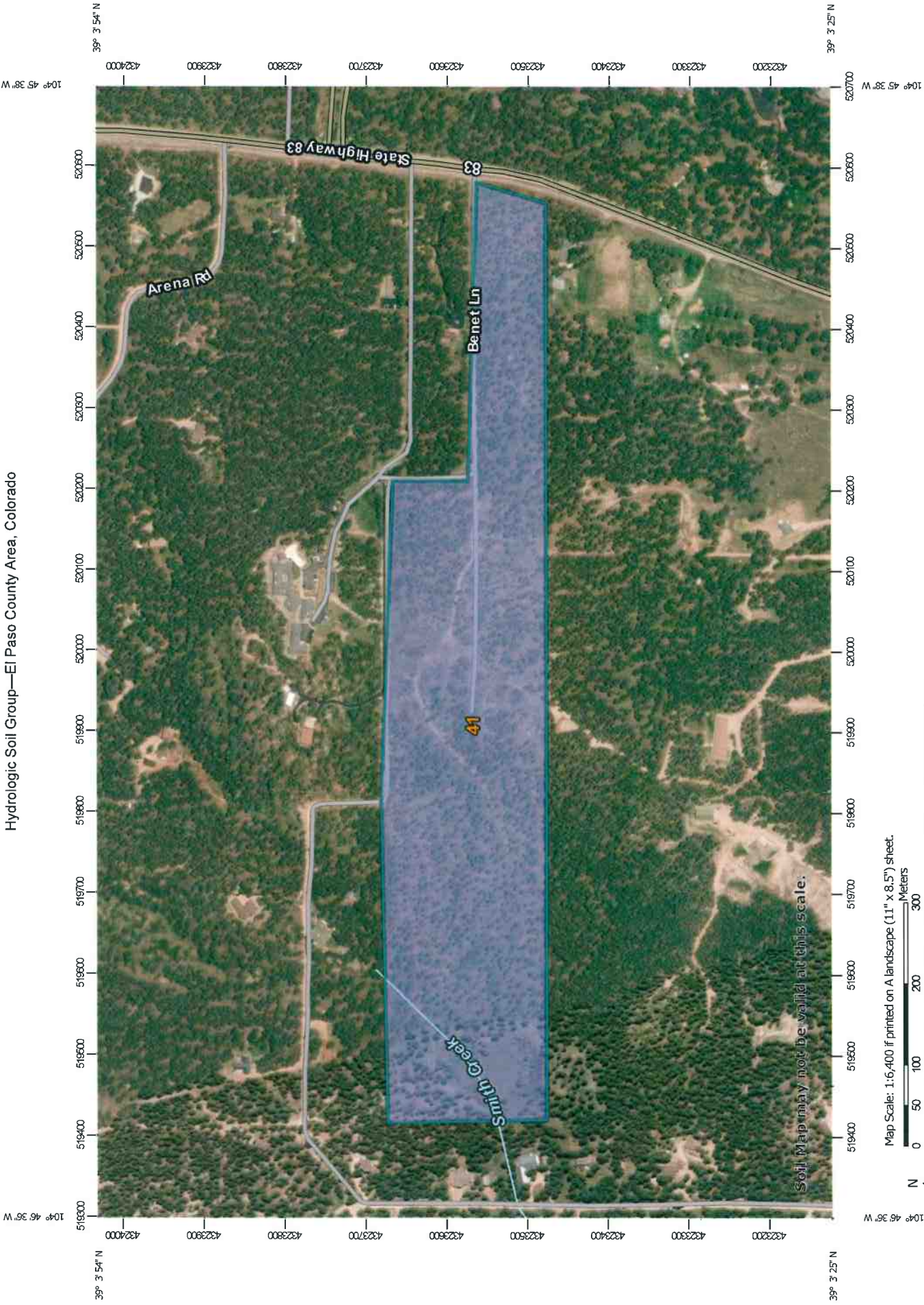

























Soil Map may not be valid at this scale.

Map Scale: 1:6,400 if printed on A landscape (11" x 8.5") sheet.



Map projection: Web Mercator Corner coordinates: WGS84 Edge tics: UTM Zone 13N WGS84

MAP LEGEND

Area of Interest (AOI)	 C
 Area of Interest (AOI)	 C/D
Soils	 D
Soil Rating Polygons	 Not rated or not available
 A	Water Features
 A/D	 Streams and Canals
 B	Transportation
 B/D	 Rails
 C	 Interstate Highways
 C/D	 US Routes
 D	 Major Roads
 Not rated or not available	 Local Roads
Soil Rating Lines	Background
 A	 Aerial Photography
 A/D	
 B	
 B/D	
 C	
C/D	
D	
Not rated or not available	
Soil Rating Points	
A	
A/D	
B	
B/D	

MAP INFORMATION

The soil surveys that comprise your AOI were mapped at 1:24,000.

Warning: Soil Map may not be valid at this scale.

Enlargement of maps beyond the scale of mapping can cause misunderstanding of the detail of mapping and accuracy of soil line placement. The maps do not show the small areas of contrasting soils that could have been shown at a more detailed scale.

Please rely on the bar scale on each map sheet for map measurements.

Source of Map: Natural Resources Conservation Service
 Web Soil Survey URL:
 Coordinate System: Web Mercator (EPSG:3857)

Maps from the Web Soil Survey are based on the Web Mercator projection, which preserves direction and shape but distorts distance and area. A projection that preserves area, such as the Albers equal-area conic projection, should be used if more accurate calculations of distance or area are required.

This product is generated from the USDA-NRCS certified data as of the version date(s) listed below.

Soil Survey Area: El Paso County Area, Colorado
 Survey Area Data: Version 16, Sep 10, 2018

Soil map units are labeled (as space allows) for map scales 1:50,000 or larger.

Date(s) aerial images were photographed: Jul 4, 2010—Oct 16, 2017

The orthophoto or other base map on which the soil lines were compiled and digitized probably differs from the background imagery displayed on these maps. As a result, some minor shifting of map unit boundaries may be evident.

Hydrologic Soil Group

Map unit symbol	Map unit name	Rating	Acres in AOI	Percent of AOI
41	Kettle gravelly loamy sand, 8 to 40 percent slopes	B	47.2	100.0%
Totals for Area of Interest			47.2	100.0%

Description

Hydrologic soil groups are based on estimates of runoff potential. Soils are assigned to one of four groups according to the rate of water infiltration when the soils are not protected by vegetation, are thoroughly wet, and receive precipitation from long-duration storms.

The soils in the United States are assigned to four groups (A, B, C, and D) and three dual classes (A/D, B/D, and C/D). The groups are defined as follows:

Group A. Soils having a high infiltration rate (low runoff potential) when thoroughly wet. These consist mainly of deep, well drained to excessively drained sands or gravelly sands. These soils have a high rate of water transmission.

Group B. Soils having a moderate infiltration rate when thoroughly wet. These consist chiefly of moderately deep or deep, moderately well drained or well drained soils that have moderately fine texture to moderately coarse texture. These soils have a moderate rate of water transmission.

Group C. Soils having a slow infiltration rate when thoroughly wet. These consist chiefly of soils having a layer that impedes the downward movement of water or soils of moderately fine texture or fine texture. These soils have a slow rate of water transmission.

Group D. Soils having a very slow infiltration rate (high runoff potential) when thoroughly wet. These consist chiefly of clays that have a high shrink-swell potential, soils that have a high water table, soils that have a claypan or clay layer at or near the surface, and soils that are shallow over nearly impervious material. These soils have a very slow rate of water transmission.

If a soil is assigned to a dual hydrologic group (A/D, B/D, or C/D), the first letter is for drained areas and the second is for undrained areas. Only the soils that in their natural condition are in group D are assigned to dual classes.

Rating Options

Aggregation Method: Dominant Condition

Component Percent Cutoff: None Specified

Tie-break Rule: Higher

Table 6-6. Runoff Coefficients for Rational Method
(Source: UDFCD 2001)

Land Use or Surface Characteristics	Percent Impervious	Runoff Coefficients															
		2-year		5-year		10-year		25-year		50-year		100-year					
		HSG A&B	HSG C&D	HSG A&B	HSG C&D	HSG A&B	HSG C&D	HSG A&B	HSG C&D	HSG A&B	HSG C&D	HSG A&B	HSG C&D				
Business																	
Commercial Areas	95	0.79	0.80	0.81	0.82	0.83	0.84	0.85	0.87	0.87	0.88	0.88	0.89				
Neighborhood Areas	70	0.45	0.49	0.49	0.53	0.53	0.57	0.58	0.62	0.62	0.65	0.62	0.68				
Residential																	
1/8 Acre or less	65	0.41	0.45	0.45	0.49	0.49	0.54	0.54	0.59	0.59	0.62	0.59	0.65				
1/4 Acre	40	0.23	0.28	0.30	0.35	0.36	0.42	0.42	0.50	0.50	0.54	0.50	0.58				
1/3 Acre	30	0.18	0.22	0.25	0.30	0.32	0.38	0.39	0.47	0.47	0.52	0.47	0.57				
1/2 Acre	25	0.15	0.20	0.22	0.28	0.30	0.36	0.37	0.46	0.46	0.51	0.46	0.56				
1 Acre	20	0.12	0.17	0.20	0.26	0.27	0.34	0.35	0.44	0.44	0.50	0.44	0.55				
Industrial																	
Light Areas	80	0.57	0.60	0.59	0.63	0.63	0.66	0.66	0.70	0.68	0.72	0.70	0.74				
Heavy Areas	90	0.71	0.73	0.73	0.75	0.75	0.77	0.78	0.80	0.80	0.82	0.81	0.83				
Parks and Cemeteries	7	0.05	0.09	0.12	0.19	0.20	0.29	0.30	0.40	0.34	0.46	0.39	0.52				
Playgrounds	13	0.07	0.13	0.16	0.23	0.24	0.31	0.32	0.42	0.37	0.48	0.41	0.54				
Railroad Yard Areas	40	0.23	0.28	0.30	0.35	0.36	0.42	0.42	0.50	0.46	0.54	0.50	0.58				
Undeveloped Areas																	
Historic Flow Analysis--																	
Greenbelts, Agriculture	2	0.03	0.05	0.09	0.16	0.17	0.26	0.26	0.38	0.31	0.45	0.36	0.51				
Pasture/Meadow	0	0.02	0.04	0.08	0.15	0.15	0.25	0.25	0.37	0.30	0.44	0.35	0.50				
Forest	0	0.02	0.04	0.08	0.15	0.15	0.25	0.25	0.37	0.30	0.44	0.35	0.50				
Exposed Rock	100	0.89	0.89	0.90	0.90	0.92	0.92	0.94	0.94	0.95	0.95	0.96	0.96				
Offsite Flow Analysis (when landuse is undefined)	45	0.26	0.31	0.32	0.37	0.38	0.44	0.44	0.51	0.48	0.55	0.51	0.59				
Streets																	
Paved	100	0.89	0.89	0.90	0.90	0.92	0.92	0.94	0.94	0.95	0.95	0.96	0.96				
Gravel	80	0.57	0.60	0.59	0.63	0.63	0.66	0.66	0.70	0.68	0.72	0.70	0.74				
Drive and Walks	100	0.89	0.89	0.90	0.90	0.92	0.92	0.94	0.94	0.95	0.95	0.96	0.96				
Roofs	90	0.71	0.73	0.73	0.75	0.75	0.77	0.78	0.80	0.80	0.82	0.81	0.83				
Lawns	0	0.02	0.04	0.08	0.15	0.15	0.25	0.25	0.37	0.30	0.44	0.35	0.50				

Figure 6-5. Colorado Springs Rainfall Intensity Duration Frequency

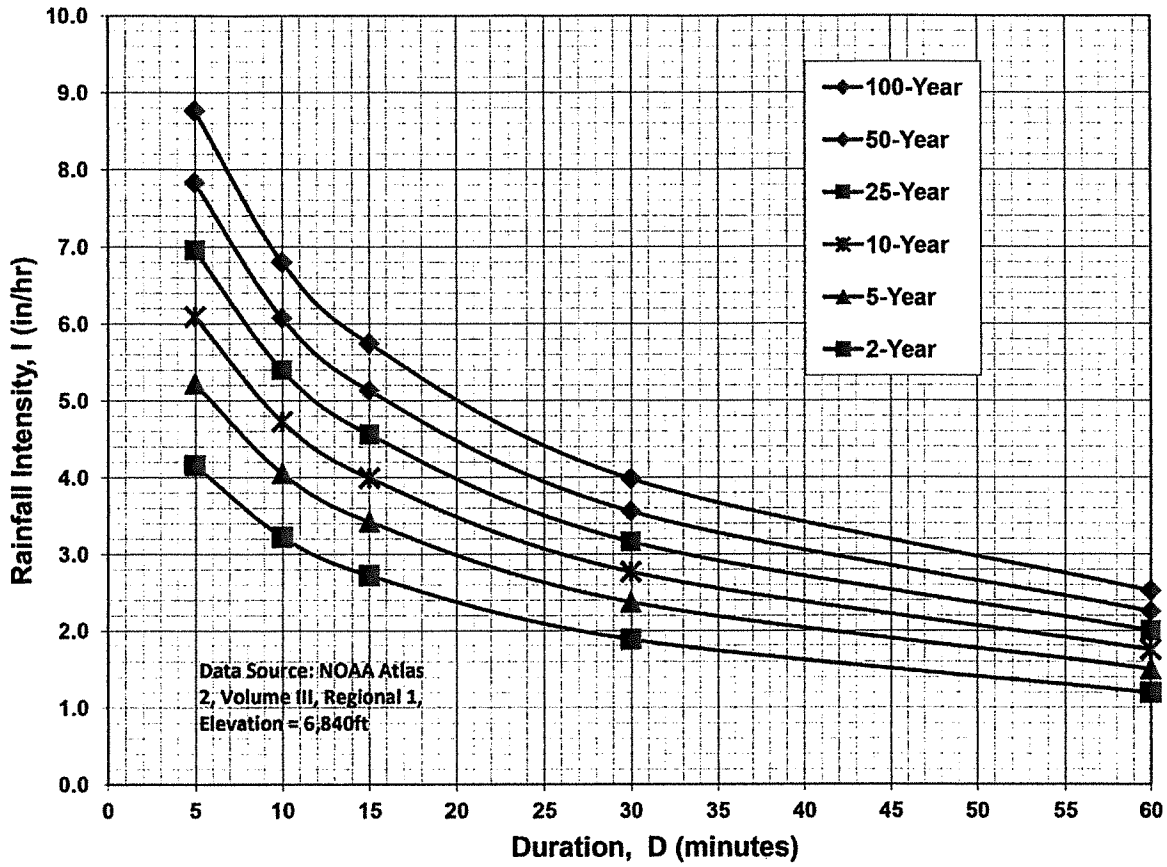

IDF Equations

$$I_{100} = -2.52 \ln(D) + 12.735$$

$$I_{50} = -2.25 \ln(D) + 11.375$$

$$I_{25} = -2.00 \ln(D) + 10.111$$

$$I_{10} = -1.75 \ln(D) + 8.847$$

$$I_5 = -1.50 \ln(D) + 7.583$$

$$I_2 = -1.19 \ln(D) + 6.035$$

Note: Values calculated by equations may not precisely duplicate values read from figure.

Job No.: 61087

Project: Sanctuary of Peace

Date: 9/12/2019 15:12

Calcs By: ASM

Checked By:

Time of Concentration (Modified from Standard Form SF-1)

Sub-Basin	Sub-Basin Data			Overland			Shallow Channel			Channelized			t _c Check					
	Area (Acres)	C ₅	C ₁₀₀ /CN	% Imp.	L ₀ (ft)	S ₀ (%)	t _i (min)	L _{0t} (ft)	S _{0t} (ft/ft)	V _{osc} (ft/s)	t _i (min)	L _{0c} (ft)	S _{0c} (ft/ft)	V _{oc} (ft/s)	t _c (min)	L (min)	t _{c,att} (min)	t _c (min)
EX-A1	30.11	0.08	0.35	0%	100	9%	8.9	1483	0.072	1.9	13.1	117	0.043	1.6	1.2	1700	N/A	23.3
EX-B1	2.06	0.08	0.35	0%	100	8%	9.3	383	0.044	1.5	4.3	84	0.060	1.9	0.8	567	N/A	14.4
EX-B2	8.75	0.08	0.35	0%	100	7%	9.7	211	0.047	1.5	2.3	0	0.000	0.0	0.0	311	N/A	12.0
EX-C1	5.68	0.08	0.35	0%	100	11%	8.3	622	0.040	1.4	7.4	0	0.000	0.0	0.0	722	N/A	15.7
EX-C2	2.03	0.08	0.35	0%	100	8%	9.3	200	0.085	2.0	1.6	0	0.000	0.0	0.0	300	N/A	10.9
EX-C3	0.66	0.08	0.35	0%	100	10%	8.6	117	0.060	1.7	1.1	0	0.000	0.0	0.0	217	N/A	9.8
OSA	69.40	0.08	0.35	0%	100	3%	12.8	1030	0.063	1.8	9.8	1887	0.041	1.6	19.4	3017	N/A	41.9
OS B	83.92	0.10	0.37	3%	100	3%	12.5	1030	0.063	1.8	9.8	1887	0.041	1.6	19.4	3017	N/A	41.7
OS C	49.12	0.12	0.38	5%	100	5%	10.4	995	0.070	1.9	8.9	597	0.090	2.2	4.6	1692	N/A	23.9
A1	1.85	0.36	0.55	36%	100	11%	6.1	217	0.055	1.2	3.1	0	0.000	0.0	0.0	317	N/A	9.1
A2	28.30	0.08	0.35	0%	100	9%	8.9	1483	0.072	1.3	18.4	117	0.043	5.7	0.3	1700	N/A	27.7
B1	2.36	0.08	0.35	0%	100	8%	9.3	383	0.044	1.5	4.3	84	0.060	1.9	0.8	567	N/A	14.4
B2	9.23	0.10	0.36	2%	100	7%	9.5	211	0.047	1.5	2.3	0	0.000	0.0	0.0	311	N/A	11.8
C1	4.07	0.27	0.49	25%	100	16%	6.0	457	0.046	1.1	7.1	0	0.000	0.0	0.0	557	N/A	13.1
C2	0.66	0.28	0.49	27%	89	7%	7.5	100	0.060	1.2	1.4	0	0.000	0.0	0.0	189	N/A	8.8
C3	1.36	0.08	0.35	0%	100	7%	9.7	173	0.075	1.4	2.1	0	0.000	0.0	0.0	273	N/A	11.8
C4	0.64	0.08	0.35	0%	81	14%	7.0	140	0.071	1.3	1.7	0	0.000	0.0	0.0	221	N/A	8.8
C5	1.61	0.08	0.35	0%	100	10%	8.6	123	0.065	1.3	1.6	0	0.000	0.0	0.0	223	N/A	10.2

Job No.: 61087
 Project: Sanctuary of Peace
 Design Storm: 5-Year Storm (20% Probability)
 Jurisdiction: DCM

Date: 9/16/2019 14:37
 Calcs By: ASM
 Checked By:

Sub-Basin and Combined Flows (Modified from Standard Form SF-2)

DP	Sub-Basin	Area (Acres)	C5	Direct Runoff			Combined Runoff			Streetflow			Pipe Flow			Travel Time				
				t _c (min)	CA (Acres)	I5 (in/hr)	Q5 (cfs)	t _c (min)	CA (Acres)	I5 (in/hr)	Q5 (cfs)	Slope (%)	Length (ft)	Q (cfs)	Slope (%)	n	Length (ft)	D _{Pipe} (in)	Length (ft)	V _{osc} (ft/s)
	EX-A1	30.11	0.08	23.3	2.41	2.86	6.9													
	EX-B1	2.06	0.08	14.4	0.16	3.59	0.6													
	EX-B2	8.75	0.08	12.0	0.70	3.86	2.7													
	EX-C1	5.68	0.08	15.7	0.45	3.45	1.6													
	EX-C2	2.03	0.08	10.9	0.16	4.00	0.7													
	EX-C3	0.66	0.08	9.8	0.05	4.17	0.2													
	OSA	69.40	0.08	41.9	5.77	1.98	11.4													
	OSB	83.92	0.10	41.7	8.73	1.99	17.4													
	OSC	49.12	0.12	23.9	5.87	2.82	16.6													
	A1	1.85	0.36	9.1	0.66	4.26	2.8													
	A2	28.30	0.08	27.7	2.26	2.60	5.9													
	B1	2.36	0.08	14.4	0.19	3.59	0.7													
	B2	9.23	0.10	11.8	0.89	3.87	3.4													
	C1	4.07	0.27	13.1	1.11	3.72	4.1													
	C2	0.66	0.28	8.8	0.18	4.32	0.8													
	C3	1.36	0.08	11.8	0.11	3.88	0.4													
	C4	0.64	0.08	8.8	0.05	4.33	0.2													
	C5	1.61	0.08	10.2	0.13	4.10	0.5													
EX1		153.32	0.09					41.9	14.13	2.53	35.7									
EX4		2.03	0.08					10.9	0.16	4.00	0.7									
EX5		0.66	0.08					9.8	0.05	4.17	0.2									
EX7		5.68	0.08					15.7	0.45	3.45	1.6									
EX9		59.93	0.11					23.9	6.73	2.82	19.0									
DP1		183.47	0.09					9.1	16.93	4.26	34.8									
DP2		1.85	0.36					9.1	0.66	4.26	2.8									
DP3		0.66	0.28					8.8	0.18	4.32	0.8									
DP4		2.02	0.08					11.8	0.16	3.88	0.4									
DP5		0.64	0.08					8.8	0.05	4.33	0.2									
DP6		4.07	0.27					13.1	1.11	3.72	4.1									
DP7		5.69	0.08					10.2	0.45	4.10	0.6									
DP8		2.36	0.08					14.4	0.19	3.59	0.7									
DP9		60.72	0.11					14.4	6.94	3.59	24.9									

DCM: $I = C1 * In(tc) + C2$
 C1: 1.5
 C1: 7.683

Job No.: 61087
 Project: Sanctuary of Peace
 Design Storm: 100-Year Storm (1% Probability)
 Jurisdiction: DCM

Date: 9/16/2019 14:38
 Calcs By: ASM
 Checked By:

Sub-Basin and Combined Flows (Modified from Standard Form SF-2)

DP	Sub-Basin	Area (Acres)	C100	Direct Runoff			Combined Runoff			Streetflow			Pipe Flow			Travel Time		
				t _c (min)	CA (Acres)	I100 (in/hr)	Q100 (cfs)	t _c (min)	CA (Acres)	I100 (in/hr)	Q100 (cfs)	Slope (%)	Length (ft)	Q (cfs)	Slope (%)	Length (ft)	D _{pipe} (in)	Length (ft)
	EX-A1	30.11	0.35	23.3	10.54	4.81	50.6											
	EX-B1	2.06	0.35	14.4	0.72	6.02	4.3											
	EX-B2	8.75	0.35	12.0	3.06	6.47	19.8											
	EX-C1	5.68	0.35	15.7	1.99	5.79	11.5											
	EX-C2	2.03	0.35	10.9	0.71	6.71	4.8											
	EX-C3	0.66	0.35	9.8	0.23	7.00	1.6											
	OSA	69.40	0.35	41.9	24.44	3.32	81.1											
	OSB	83.92	0.37	41.7	30.79	3.34	102.7											
	OSC	49.12	0.38	23.9	18.61	4.73	88.1											
	A1	1.85	0.55	9.1	1.02	7.16	7.3											
	A2	28.30	0.35	27.7	9.90	4.37	43.3											
	B1	2.36	0.35	14.4	0.83	6.02	5.0											
	B2	9.23	0.36	11.8	3.34	6.51	21.7											
	C1	4.07	0.49	13.1	1.99	6.25	12.5											
	C2	0.66	0.49	8.8	0.33	7.25	2.4											
	C3	1.36	0.35	11.8	0.48	6.52	3.1											
	C4	0.64	0.35	8.8	0.23	7.27	1.6											
	C5	1.61	0.35	10.2	0.56	6.88	3.9											
EX1		153.32	0.36					41.9	54.97	4.23	232.4							
EX4		2.03	0.35					10.9	0.71	6.71	4.8							
EX5		0.66	0.35					9.8	0.23	7.00	1.6							
EX7		5.68	0.35					15.7	1.99	5.79	11.5							
EX9		59.93	0.37					23.9	22.39	4.73	106.0							
DP1		183.47	0.36					9.1	65.80	3.50	230.2							
DP2		1.85	0.55					9.1	1.02	7.16	7.3							
DP3		0.66	0.49					8.8	0.33	7.25	2.4							
DP4		1.36	0.35					11.8	0.48	6.52	4.2							
DP5		0.64	0.35					8.8	0.23	7.27	1.6							
DP6		4.07	0.49					13.1	1.99	6.25	12.5							
DP7		1.61	0.35					10.2	0.56	6.88	10.0							
DP8		2.36	0.35					14.4	0.83	6.02	5.0							
DP9		60.72	0.38					14.4	22.78	6.02	137.2							

DCM: $I = C1 * \ln(tc) + C2$
 C1: 2.52
 C2: 12.735

Sub-Basin Ex-A1 Runoff Calculations

Job No.:	61087	Date:	9/16/2019 10:38
Project:	Sanctuary of Peace	Calcs by:	ASM
Jurisdiction	DCM	Checked by:	
Runoff Coefficient	Surface Type	Soil Type	B
		Urbanization	Non-Urban

Basin Land Use Characteristics

Surface	Area		Runoff Coefficient						% Imperv.
	(SF)	(Acres)	C2	C5	C10	C25	C50	C100	
Forest	1,311,446	30.11	0.02	0.08	0.15	0.25	0.3	0.35	0%
Combined	1,311,446	30.11	0.02	0.08	0.15	0.25	0.30	0.35	0.0%

4000

Basin Travel Time

	Shallow Channel Ground Cover		Short Pasture/Lawns			
	$L_{max, Overland}$	100 ft	S_0	v	t	t_{Alt}
	L (ft)	ΔZ_0 (ft)	(ft/ft)	(ft/s)	(min)	(min)
Total	1,700	121	-	-	-	-
Initial Time	100	9	0.090	-	8.9	N/A DCM Eq. 6-8
Shallow Channel	1,483	107	0.072	1.9	13.1	- DCM Eq. 6-9
Channelized	117	5	0.043	1.6	1.2	- V-Ditch
				t_c	23.3 min.	

Rainfall Intensity & Runoff

	2-Yr	5-Yr	10-Yr	25-Yr	50-Yr	100-Yr
Intensity (in/hr)	2.29	2.86	3.34	3.82	4.30	4.81
Runoff (cfs)	1.4	6.9	15.1	28.7	38.8	50.6
Release Rates (cfs/ac)	-	-	-	-	-	-
Allowed Release (cfs)	1.4	6.9	15.1	28.7	38.8	50.6

DCM: $I = C1 * \ln(tc) + C2$

C1	1.19	1.5	1.75	2	2.25	2.52
C2	6.035	7.583	8.847	10.111	11.375	12.735

Notes

Sub-Basin Ex-B1 Runoff Calculations

Job No.: 61087 Date: 9/16/2019 10:38
 Project: Sanctuary of Peace Calcs by: ASM
 Checked by: _____
 Jurisdiction: DCM Soil Type: B
 Runoff Coefficient: Surface Type Urbanization: Non-Urban

Basin Land Use Characteristics

Surface	Area		Runoff Coefficient						% Imperv.
	(SF)	(Acres)	C2	C5	C10	C25	C50	C100	
Forest	89,528	2.06	0.02	0.08	0.15	0.25	0.3	0.35	0%
	-	0.00							
Combined	89,528	2.06	0.02	0.08	0.15	0.25	0.30	0.35	0.0%

4000

Basin Travel Time

	Shallow Channel Ground Cover		Short Pasture/Lawns			
	$L_{max,Overland}$	100 ft	C_v	7		
	L (ft)	ΔZ_0 (ft)	S_0 (ft/ft)	v (ft/s)	t (min)	t_{Att} (min)
Total	567	30	-	-	-	-
Initial Time	100	8	0.080	-	9.3	N/A DCM Eq. 6-8
Shallow Channel	383	17	0.044	1.5	4.3	- DCM Eq. 6-9
Channelized	84	5	0.060	1.9	0.8	- V-Ditch
				t_c	14.4 min.	

Rainfall Intensity & Runoff

	2-Yr	5-Yr	10-Yr	25-Yr	50-Yr	100-Yr
Intensity (in/hr)	2.86	3.59	4.18	4.78	5.38	6.02
Runoff (cfs)	0.1	0.6	1.3	2.5	3.3	4.3
Release Rates (cfs/ac)	-	-	-	-	-	-
Allowed Release (cfs)	0.1	0.6	1.3	2.5	3.3	4.3

DCM: $I = C1 * \ln(tc) + C2$

C1	1.19	1.5	1.75	2	2.25	2.52
C2	6.035	7.583	8.847	10.111	11.375	12.735

Notes

Sub-Basin Ex-B2 Runoff Calculations

Job No.: 61087 Date: 9/16/2019 10:38
 Project: Sanctuary of Peace Calcs by: ASM
 Checked by: _____
 Jurisdiction: DCM Soil Type: B
 Runoff Coefficient: Surface Type Urbanization: Non-Urban

Basin Land Use Characteristics

Surface	Area		Runoff Coefficient						% Imperv.
	(SF)	(Acres)	C2	C5	C10	C25	C50	C100	
Forest	381,146	8.75	0.02	0.08	0.15	0.25	0.3	0.35	0%
	-	0.00							
Combined	381,146	8.75	0.02	0.08	0.15	0.25	0.30	0.35	0.0%

4000

Basin Travel Time

	Shallow Channel Ground Cover		Short Pasture/Lawns			
	$L_{max,Overland}$	100 ft	S_0	v	t	t_{Alt}
	L (ft)	ΔZ_0 (ft)	(ft/ft)	(ft/s)	(min)	(min)
Total	311	17	-	-	-	-
Initial Time	100	7	0.070	-	9.7	N/A DCM Eq. 6-8
Shallow Channel	211	10	0.047	1.5	2.3	- DCM Eq. 6-9
Channelized			0.000	0.0	0.0	- V-Ditch
				t_c	12.0 min.	

Rainfall Intensity & Runoff

	2-Yr	5-Yr	10-Yr	25-Yr	50-Yr	100-Yr
Intensity (in/hr)	3.08	3.86	4.50	5.14	5.78	6.47
Runoff (cfs)	0.5	2.7	5.9	11.2	15.2	19.8
Release Rates (cfs/ac)	-	-	-	-	-	-
Allowed Release (cfs)	0.5	2.7	5.9	11.2	15.2	19.8

DCM: $I = C1 * \ln(tc) + C2$

C1	1.19	1.5	1.75	2	2.25	2.52
C2	6.035	7.583	8.847	10.111	11.375	12.735

Notes

Sub-Basin Ex-C1 Runoff Calculations

Job No.: 61087
 Project: Sanctuary of Peace
 Jurisdiction: DCM
 Runoff Coefficient: Surface Type

Date: 9/16/2019 10:38
 Calcs by: ASM
 Checked by: _____
 Soil Type: B
 Urbanization: Non-Urban

Basin Land Use Characteristics

Surface	Area		Runoff Coefficient						% Imperv.
	(SF)	(Acres)	C2	C5	C10	C25	C50	C100	
Forest	247,407	5.68	0.02	0.08	0.15	0.25	0.3	0.35	0%
	-	0.00							
Combined	247,407	5.68	0.02	0.08	0.15	0.25	0.30	0.35	0.0%

4000

Basin Travel Time

	Shallow Channel Ground Cover		Short Pasture/Lawns			
	$L_{max, Overland}$	100 ft	S_0	v	t	t_{Alt}
	L (ft)	ΔZ_0 (ft)	(ft/ft)	(ft/s)	(min)	(min)
Total	722	36	-	-	-	-
Initial Time	100	11	0.110	-	8.3	N/A DCM Eq. 6-8
Shallow Channel	622	25	0.040	1.4	7.4	- DCM Eq. 6-9
Channelized			0.000	0.0	0.0	- V-Ditch
				t_c	15.7 min.	

Rainfall Intensity & Runoff

	2-Yr	5-Yr	10-Yr	25-Yr	50-Yr	100-Yr
Intensity (in/hr)	2.76	3.45	4.02	4.60	5.17	5.79
Runoff (cfs)	0.3	1.6	3.4	6.5	8.8	11.5
Release Rates (cfs/ac)	-	-	-	-	-	-
Allowed Release (cfs)	0.3	1.6	3.4	6.5	8.8	11.5

DCM: $t = C1 * \ln(tc) + C2$

C1	1.19	1.5	1.75	2	2.25	2.52
C2	6.035	7.583	8.847	10.111	11.375	12.735

Notes

Sub-Basin Ex-C2 Runoff Calculations

Job No.: 61087
 Project: Sanctuary of Peace
 Jurisdiction: DCM
 Runoff Coefficient: Surface Type

Date: 9/16/2019 10:38
 Calcs by: ASM
 Checked by: _____
 Soil Type: B
 Urbanization: Non-Urban

Basin Land Use Characteristics

Surface	Area		Runoff Coefficient						% Imperv.
	(SF)	(Acres)	C2	C5	C10	C25	C50	C100	
Forest	88,571	2.03	0.02	0.08	0.15	0.25	0.3	0.35	0%
	-	0.00							
Combined	88,571	2.03	0.02	0.08	0.15	0.25	0.30	0.35	0.0%

Basin Travel Time

	Shallow Channel Ground Cover		Short Pasture/Lawns			
	$L_{max, Overland}$	100 ft	S_0	v	t	t_{Alt}
	L (ft)	ΔZ_0 (ft)	(ft/ft)	(ft/s)	(min)	(min)
Total	300	25	-	-	-	-
Initial Time	100	8	0.080	-	9.3	N/A DCM Eq. 6-8
Shallow Channel	200	17	0.085	2.0	1.6	- DCM Eq. 6-9
Channelized			0.000	0.0	0.0	- V-Ditch
				t_c	10.9 min.	

Rainfall Intensity & Runoff

	2-Yr	5-Yr	10-Yr	25-Yr	50-Yr	100-Yr
Intensity (in/hr)	3.19	4.00	4.67	5.33	6.00	6.71
Runoff (cfs)	0.1	0.7	1.4	2.7	3.7	4.8
Release Rates (cfs/ac)	-	-	-	-	-	-
Allowed Release (cfs)	0.1	0.7	1.4	2.7	3.7	4.8

DCM: $I = C1 * \ln(tc) + C2$

C1	1.19	1.5	1.75	2	2.25	2.52
C2	6.035	7.583	8.847	10.111	11.375	12.735

Notes

Sub-Basin Ex-C3 Runoff Calculations

Job No.: 61087
 Project: Sanctuary of Peace
 Jurisdiction: DCM
 Runoff Coefficient: Surface Type

Date: 9/16/2019 10:38
 Calcs by: ASM
 Checked by: _____
 Soil Type: B
 Urbanization: Non-Urban

Basin Land Use Characteristics

Surface	Area		Runoff Coefficient						% Imperv.
	(SF)	(Acres)	C2	C5	C10	C25	C50	C100	
Forest	28,874	0.66	0.02	0.08	0.15	0.25	0.3	0.35	0%
	-	0.00							
Combined	28,874	0.66	0.02	0.08	0.15	0.25	0.30	0.35	0.0%

Basin Travel Time

	Shallow Channel Ground Cover		Short Pasture/Lawns			
	$L_{max,Overland}$	100 ft	S_0	v	t	t_{Alt}
	L (ft)	ΔZ_0 (ft)	(ft/ft)	(ft/s)	(min)	(min)
Total	217	17	-	-	-	-
Initial Time	100	10	0.100	-	8.6	N/A DCM Eq. 6-8
Shallow Channel	117	7	0.060	1.7	1.1	- DCM Eq. 6-9
Channelized			0.000	0.0	0.0	- V-Ditch
				t_c	9.8 min.	

Rainfall Intensity & Runoff

	2-Yr	5-Yr	10-Yr	25-Yr	50-Yr	100-Yr
Intensity (in/hr)	3.32	4.17	4.86	5.56	6.25	7.00
Runoff (cfs)	0.0	0.2	0.5	0.9	1.2	1.6
Release Rates (cfs/ac)	-	-	-	-	-	-
Allowed Release (cfs)	0.0	0.2	0.5	0.9	1.2	1.6

DCM: $I = C1 * \ln(tc) + C2$

C1	1.19	1.5	1.75	2	2.25	2.52
C2	6.036	7.583	8.847	10.111	11.375	12.735

Notes

Sub-Basin OS A Runoff Calculations

Job No.: 61087
 Project: Sanctuary of Peace
 Jurisdiction: DCM
 Runoff Coefficient: Surface Type

Date: 9/16/2019 10:38
 Calcs by: ASM
 Checked by: _____
 Soil Type: B
 Urbanization: Non-Urban

Basin Land Use Characteristics

Surface	Area		Runoff Coefficient						%
	(SF)	(Acres)	C2	C5	C10	C25	C50	C100	Imperv.
Forest	3,004,559	68.98	0.02	0.08	0.15	0.25	0.3	0.35	0%
Gravel	18,357	0.42	0.57	0.59	0.63	0.66	0.68	0.7	80%
	-	0.00							
	-	0.00							
Combined	3,022,916	69.40	0.02	0.08	0.15	0.25	0.30	0.35	0.5%

4000

Basin Travel Time

	Shallow Channel Ground Cover		Short Pasture/Lawns				
	$L_{max,Overland}$	100 ft			C_v	7	
	L (ft)	ΔZ_0 (ft)	S_0 (ft/ft)	v (ft/s)	t (min)	t_{Alt} (min)	
Total	3,017	146	-	-	-	-	
Initial Time	100	3	0.030	-	12.8	N/A	DCM Eq. 6-8
Shallow Channel	1,030	65	0.063	1.8	9.8	-	DCM Eq. 6-9
Channelized	1,887	78	0.041	1.6	19.4	-	V-Ditch
				t_c	41.9 min.		

Rainfall Intensity & Runoff

	2-Yr	5-Yr	10-Yr	25-Yr	50-Yr	100-Yr
Intensity (in/hr)	1.59	1.98	2.31	2.64	2.97	3.32
Runoff (cfs)	2.6	11.4	24.5	46.2	62.3	81.1
Release Rates (cfs/ac)	-	-	-	-	-	-
Allowed Release (cfs)	2.6	11.4	24.5	46.2	62.3	81.1

DCM: $I = C1 * \ln(tc) + C2$

C1	1.19	1.5	1.75	2	2.25	2.52
C2	6.035	7.583	8.847	10.111	11.375	12.735

Notes

Sub-Basin OS B Runoff Calculations

Job No.: 61087
 Project: Sanctuary of Peace
 Jurisdiction: DCM
 Runoff Coefficient: Surface Type

Date: 9/16/2019 10:38
 Calcs by: ASM
 Checked by: _____
 Soil Type: B
 Urbanization: Non-Urban

Basin Land Use Characteristics

Surface	Area		Runoff Coefficient						% Imperv.
	(SF)	(Acres)	C2	C5	C10	C25	C50	C100	
Forest	3,507,946	80.53	0.02	0.08	0.15	0.25	0.3	0.35	0%
Driveways & Walks	16,239	0.37	0.89	0.9	0.92	0.94	0.95	0.96	100%
Gravel	77,470	1.78	0.57	0.59	0.63	0.66	0.68	0.7	80%
Roofs	53,907	1.24	0.71	0.73	0.75	0.78	0.8	0.81	90%
Combined	3,655,562	83.92	0.05	0.10	0.17	0.27	0.32	0.37	3.5%

4000

Basin Travel Time

	Shallow Channel Ground Cover		Short Pasture/Lawns			
	$L_{max,Overland}$	100 ft	C_v	7		
	L (ft)	ΔZ_o (ft)	S_o (ft/ft)	v (ft/s)	t (min)	t_{Alt} (min)
Total	3,017	146	-	-	-	-
Initial Time	100	3	0.030	-	12.5	N/A DCM Eq. 6-8
Shallow Channel	1,030	65	0.063	1.8	9.8	- DCM Eq. 6-9
Channelized	1,887	78	0.041	1.6	19.4	- V-Ditch
				t_c	41.7 min.	

Rainfall Intensity & Runoff

	2-Yr	5-Yr	10-Yr	25-Yr	50-Yr	100-Yr
Intensity (in/hr)	1.60	1.99	2.32	2.65	2.98	3.34
Runoff (cfs)	6.1	17.4	33.6	60.0	79.7	102.7
Release Rates (cfs/ac)	-	-	-	-	-	-
Allowed Release (cfs)	6.1	17.4	33.6	60.0	79.7	102.7

DCM: $I = C1 * \ln(tc) + C2$

C1	1.19	1.5	1.75	2	2.25	2.52
C2	6.035	7.583	8.847	10.111	11.375	12.735

Notes

Sub-Basin OS C Runoff Calculations

Job No.: 61087 Date: 9/16/2019 10:38
 Project: Sanctuary of Peace Calcs by: ASM
 Checked by: _____
 Jurisdiction: DCM Soil Type: B
 Runoff Coefficient: Surface Type Urbanization: Non-Urban

Basin Land Use Characteristics

Surface	Area		Runoff Coefficient						% Imperv.
	(SF)	(Acres)	C2	C5	C10	C25	C50	C100	
Forest	2,023,425	46.45	0.02	0.08	0.15	0.25	0.3	0.35	0%
Driveways & Walks	76,619	1.76	0.89	0.9	0.92	0.94	0.95	0.96	100%
Gravel	29,852	0.69	0.57	0.59	0.63	0.66	0.68	0.7	80%
Roofs	9,943	0.23	0.71	0.73	0.75	0.78	0.8	0.81	90%
Combined	2,139,839	49.12	0.06	0.12	0.19	0.28	0.33	0.38	5.1%

4000

Basin Travel Time

	Shallow Channel Ground Cover		Short Pasture/Lawns			
	$L_{max, Overland}$	100 ft			C_v	7
	L (ft)	ΔZ_0 (ft)	S_0 (ft/ft)	v (ft/s)	t (min)	t_{Att} (min)
Total	1,692	129	-	-	-	-
Initial Time	100	5	0.050	-	10.4	N/A DCM Eq. 6-8
Shallow Channel	995	70	0.070	1.9	8.9	- DCM Eq. 6-9
Channelized	597	54	0.090	2.2	4.6	- V-Ditch
				t_c	23.9 min.	

Rainfall Intensity & Runoff

	2-Yr	5-Yr	10-Yr	25-Yr	50-Yr	100-Yr
Intensity (in/hr)	2.26	2.82	3.29	3.76	4.23	4.73
Runoff (cfs)	6.9	16.6	30.2	52.3	68.8	88.1
Release Rates (cfs/ac)	-	-	-	-	-	-
Allowed Release (cfs)	6.9	16.6	30.2	52.3	68.8	88.1

DCM: $t = C1 * \ln(t_c) + C2$

C1	1.19	1.5	1.75	2	2.25	2.52
C2	6.035	7.583	8.847	10.111	11.375	12.735

Notes

Sub-Basin A1 Runoff Calculations

Job No.: 61087 Date: 9/16/2019 10:38
 Project: Sanctuary of Peace Calcs by: ASM
 Checked by: _____
 Jurisdiction: DCM Soil Type: B
 Runoff Coefficient: Surface Type Urbanization: Non-Urban

Basin Land Use Characteristics

Surface	Area		Runoff Coefficient						% Imperv.
	(SF)	(Acres)	C2	C5	C10	C25	C50	C100	
Forest	50,438	1.16	0.02	0.08	0.15	0.25	0.3	0.35	0%
Driveways & Walks	16,558	0.38	0.89	0.9	0.92	0.94	0.95	0.96	100%
Roofs	13,532	0.31	0.71	0.73	0.75	0.78	0.8	0.81	90%
Combined	80,528	1.85	0.31	0.36	0.41	0.48	0.52	0.55	35.7%

Basin Travel Time

Shallow Channel Ground Cover Forest							
	$L_{max,Overland}$	100 ft			C_v	5	
	L (ft)	ΔZ_o (ft)	S_o (ft/ft)	v (ft/s)	t (min)	t_{Att} (min)	
Total	317	23	-	-	-	-	
Initial Time	100	11	0.110	-	6.1	N/A	DCM Eq. 6-8
Shallow Channel	217	12	0.055	1.2	3.1	-	DCM Eq. 6-9
Channelized			0.000	0.0	0.0	-	V-Ditch
				t_c	9.1 min.		

Rainfall Intensity & Runoff

	2-Yr	5-Yr	10-Yr	25-Yr	50-Yr	100-Yr
Intensity (in/hr)	3.40	4.26	4.97	5.68	6.39	7.16
Runoff (cfs)	2.0	2.8	3.8	5.1	6.1	7.3
Release Rates (cfs/ac)	-	-	-	-	-	-
Allowed Release (cfs)	2.0	2.8	3.8	5.1	6.1	7.3

DCM: $I = C1 * \ln(tc) + C2$

C1	1.19	1.5	1.75	2	2.25	2.52
C2	6.035	7.583	8.847	10.111	11.375	12.735

Notes

Sub-Basin A2 Runoff Calculations

Job No.: 61087
 Project: Sanctuary of Peace
 Jurisdiction: DCM
 Runoff Coefficient: Surface Type

Date: 9/16/2019 10:38
 Calcs by: ASM
 Checked by: _____
 Soil Type: B
 Urbanization: Non-Urban

Basin Land Use Characteristics

Surface	Area		Runoff Coefficient						% Imperv.
	(SF)	(Acres)	C2	C5	C10	C25	C50	C100	
Forest	1,232,700	28.30	0.02	0.08	0.15	0.25	0.3	0.35	0%
Combined	1,232,700	28.30	0.02	0.08	0.15	0.25	0.30	0.35	0.0%

Basin Travel Time

	Shallow Channel Ground Cover Forest					
	$L_{max,Overland}$	100 ft			C_v	5
	L (ft)	ΔZ_0 (ft)	S_0 (ft/ft)	v (ft/s)	t (min)	t_{Alt} (min)
Total	1,700	121	-	-	-	-
Initial Time	100	9	0.090	-	8.9	N/A DCM Eq. 6-8
Shallow Channel	1,483	107	0.072	1.3	18.4	- DCM Eq. 6-9
Channelized	117	5	0.043	5.7	0.3	- V-Ditch
				t_c	27.7 min.	

Rainfall Intensity & Runoff

	2-Yr	5-Yr	10-Yr	25-Yr	50-Yr	100-Yr
Intensity (in/hr)	2.08	2.60	3.04	3.47	3.90	4.37
Runoff (cfs)	1.2	5.9	12.9	24.6	33.1	43.3
Release Rates (cfs/ac)	-	-	-	-	-	-
Allowed Release (cfs)	1.2	5.9	12.9	24.6	33.1	43.3

DCM: $i = C1 * \ln(tc) + C2$

C1	1.19	1.5	1.75	2	2.25	2.52
C2	6.035	7.583	8.847	10.111	11.375	12.735

Notes

Sub-Basin B1 Runoff Calculations

Job No.: 61087 Date: 9/16/2019 10:38
 Project: Sanctuary of Peace Calcs by: ASM
 Checked by: _____
 Jurisdiction: DCM Soil Type: B
 Runoff Coefficient: Surface Type Urbanization: Non-Urban

Basin Land Use Characteristics

Surface	Area		Runoff Coefficient						% Imperv.
	(SF)	(Acres)	C2	C5	C10	C25	C50	C100	
Forest	102,701	2.36	0.02	0.08	0.15	0.25	0.3	0.35	0%
	-	0.00							
Combined	102,701	2.36	0.02	0.08	0.15	0.25	0.30	0.35	0.0%

4000

Basin Travel Time

	Shallow Channel Ground Cover		Short Pasture/Lawns			
	$L_{max, Overland}$	100 ft	C_v	7		
	L (ft)	ΔZ_0 (ft)	S_0 (ft/ft)	v (ft/s)	t (min)	t_{Alt} (min)
Total	567	30	-	-	-	-
Initial Time	100	8	0.080	-	9.3	N/A DCM Eq. 6-8
Shallow Channel	383	17	0.044	1.5	4.3	- DCM Eq. 6-9
Channelized	84	5	0.060	1.9	0.8	- V-Ditch
				t_c	14.4 min.	

Rainfall Intensity & Runoff

	2-Yr	5-Yr	10-Yr	25-Yr	50-Yr	100-Yr
Intensity (in/hr)	2.86	3.59	4.18	4.78	5.38	6.02
Runoff (cfs)	0.1	0.7	1.5	2.8	3.8	5.0
Release Rates (cfs/ac)	-	-	-	-	-	-
Allowed Release (cfs)	0.1	0.7	1.5	2.8	3.8	5.0

DCM: $i = C1 * \ln(tc) + C2$

C1	1.19	1.5	1.75	2	2.25	2.52
C2	6.035	7.583	8.847	10.111	11.375	12.735

Notes

Sub-Basin B2 Runoff Calculations

Job No.: 61087
 Project: Sanctuary of Peace
 Jurisdiction: DCM
 Runoff Coefficient: Surface Type

Date: 9/16/2019 10:38
 Calcs by: ASM
 Checked by: _____
 Soil Type: B
 Urbanization: Non-Urban

Basin Land Use Characteristics

Surface	Area		Runoff Coefficient						% Imperv.
	(SF)	(Acres)	C2	C5	C10	C25	C50	C100	
Forest	394,481	9.06	0.02	0.08	0.15	0.25	0.3	0.35	0%
Driveways & Walks	7,783	0.18	0.89	0.9	0.92	0.94	0.95	0.96	100%
Combined	402,264	9.23	0.04	0.10	0.16	0.26	0.31	0.36	1.9%

4000

Basin Travel Time

	Shallow Channel Ground Cover		Short Pasture/Lawns			
	$L_{max,Overland}$	100 ft	C_v	7		
	L (ft)	ΔZ_o (ft)	S_o (ft/ft)	v (ft/s)	t (min)	t_{Att} (min)
Total	311	17	-	-	-	-
Initial Time	100	7	0.070	-	9.5	N/A DCM Eq. 6-8
Shallow Channel	211	10	0.047	1.5	2.3	- DCM Eq. 6-9
Channelized			0.000	0.0	0.0	- V-Ditch
				t_c	11.8 min.	

Rainfall Intensity & Runoff

	2-Yr	5-Yr	10-Yr	25-Yr	50-Yr	100-Yr
Intensity (in/hr)	3.09	3.87	4.52	5.17	5.81	6.51
Runoff (cfs)	1.1	3.4	6.9	12.6	16.8	21.7
Release Rates (cfs/ac)	-	-	-	-	-	-
Allowed Release (cfs)	1.1	3.4	6.9	12.6	16.8	21.7

DCM: $I = C1 * \ln(t_c) + C2$

C1	1.19	1.5	1.75	2	2.25	2.52
C2	6.035	7.583	8.847	10.111	11.375	12.735

Notes

Sub-Basin C1 Runoff Calculations

Job No.:	61087	Date:	9/16/2019 10:38
Project:	Sanctuary of Peace	Calcs by:	ASM
Jurisdiction	DCM	Checked by:	
Runoff Coefficient	Surface Type	Soil Type	B
		Urbanization	Non-Urban

Basin Land Use Characteristics

Surface	Area		Runoff Coefficient						% Imperv.
	(SF)	(Acres)	C2	C5	C10	C25	C50	C100	
Forest	130,377	2.99	0.02	0.08	0.15	0.25	0.3	0.35	0%
Driveways & Walks	20,192	0.46	0.89	0.9	0.92	0.94	0.95	0.96	100%
Roofs	26,845	0.62	0.71	0.73	0.75	0.78	0.8	0.81	90%
Combined	177,414	4.07	0.22	0.27	0.33	0.41	0.45	0.49	25.0%

177414

Basin Travel Time

Shallow Channel Ground Cover Forest						
	$L_{max, Overland}$	100 ft			C_v	5
	L (ft)	ΔZ_0 (ft)	S_0 (ft/ft)	v (ft/s)	t (min)	t_{Alt} (min)
Total	557	37	-	-	-	-
Initial Time	100	16	0.160	-	6.0	N/A DCM Eq. 6-8
Shallow Channel	457	21	0.046	1.1	7.1	- DCM Eq. 6-9
Channelized			0.000	0.0	0.0	- V-Ditch
				t_c	13.1 min.	

Rainfall Intensity & Runoff

	2-Yr	5-Yr	10-Yr	25-Yr	50-Yr	100-Yr
Intensity (in/hr)	2.97	3.72	4.35	4.97	5.59	6.25
Runoff (cfs)	2.7	4.1	5.8	8.3	10.2	12.5
Release Rates (cfs/ac)	-	-	-	-	-	-
Allowed Release (cfs)	2.7	4.1	5.8	8.3	10.2	12.5

DCM: $I = C1 * \ln(tc) + C2$

C1	1.19	1.5	1.75	2	2.25	2.52
C2	6.035	7.583	8.847	10.111	11.375	12.735

Notes

Sub-Basin C2 Runoff Calculations

Job No.: 61087
 Project: Sanctuary of Peace
 Jurisdiction: DCM
 Runoff Coefficient: Surface Type

Date: 9/16/2019 10:38
 Calcs by: ASM
 Checked by: _____
 Soil Type: B
 Urbanization: Non-Urban

Basin Land Use Characteristics

Surface	Area		Runoff Coefficient						%
	(SF)	(Acres)	C2	C5	C10	C25	C50	C100	Imperv.
Forest	20,454	0.47	0.02	0.08	0.15	0.25	0.3	0.35	0%
Driveways & Walks	1,280	0.03	0.89	0.9	0.92	0.94	0.95	0.96	100%
Roofs	7,150	0.16	0.71	0.73	0.75	0.78	0.8	0.81	90%
Combined	28,884	0.66	0.23	0.28	0.33	0.41	0.45	0.49	26.7%

Basin Travel Time

Shallow Channel Ground Cover Forest						
	$L_{max,Overland}$	100 ft			C_v	5
	L (ft)	ΔZ_o (ft)	S_o (ft/ft)	v (ft/s)	t (min)	t_{Att} (min)
Total	189	12	-	-	-	-
Initial Time	89	6	0.067	-	7.5	N/A DCM Eq. 6-8
Shallow Channel	100	6	0.060	1.2	1.4	- DCM Eq. 6-9
Channelized			0.000	0.0	0.0	- V-Ditch
				t_c	8.8 min.	

Rainfall Intensity & Runoff

	2-Yr	5-Yr	10-Yr	25-Yr	50-Yr	100-Yr
Intensity (in/hr)	3.44	4.32	5.04	5.76	6.48	7.25
Runoff (cfs)	0.5	0.8	1.1	1.6	1.9	2.4
Release Rates (cfs/ac)	-	-	-	-	-	-
Allowed Release (cfs)	0.5	0.8	1.1	1.6	1.9	2.4

DCM: $t = C1 * \ln(t_c) + C2$

C1	1.19	1.5	1.75	2	2.25	2.52
C2	6.035	7.583	8.847	10.111	11.375	12.735

Notes

Sub-Basin C3 Runoff Calculations

Job No.: 61087
 Project: Sanctuary of Peace
 Jurisdiction: DCM
 Runoff Coefficient: Surface Type

Date: 9/16/2019 10:38
 Calcs by: ASM
 Checked by: _____
 Soil Type: B
 Urbanization: Non-Urban

Basin Land Use Characteristics

Surface	Area		Runoff Coefficient						% Imperv.
	(SF)	(Acres)	C2	C5	C10	C25	C50	C100	
Forest	59,267	1.36	0.02	0.08	0.15	0.25	0.3	0.35	0%
Combined	59,267	1.36	0.02	0.08	0.15	0.25	0.30	0.35	0.0%

Basin Travel Time

Shallow Channel Ground Cover Forest

	$L_{max,Overland}$ (ft)	ΔZ_0 (ft)	S_0 (ft/ft)	v (ft/s)	t (min)	t_{Att} (min)	
Total	273	20	-	-	-	-	
Initial Time	100	7	0.070	-	9.7	N/A	DCM Eq. 6-8
Shallow Channel	173	13	0.075	1.4	2.1	-	DCM Eq. 6-9
Channelized			0.000	0.0	0.0	-	V-Ditch
				t_c	11.8 min.		

Rainfall Intensity & Runoff

	2-Yr	5-Yr	10-Yr	25-Yr	50-Yr	100-Yr
Intensity (in/hr)	3.10	3.88	4.53	5.18	5.82	6.52
Runoff (cfs)	0.1	0.4	0.9	1.8	2.4	3.1
Release Rates (cfs/ac)	-	-	-	-	-	-
Allowed Release (cfs)	0.1	0.4	0.9	1.8	2.4	3.1

DCM: $I = C1 * \ln(tc) + C2$

C1	1.19	1.5	1.75	2	2.25	2.52
C2	6.035	7.583	8.847	10.111	11.375	12.735

Notes

Sub-Basin C4 Runoff Calculations

Job No.: 61087
 Project: Sanctuary of Peace
 Jurisdiction: DCM
 Runoff Coefficient: Surface Type

Date: 9/16/2019 10:38
 Calcs by: ASM
 Checked by: _____
 Soil Type: B
 Urbanization: Non-Urban

Basin Land Use Characteristics

Surface	Area		Runoff Coefficient						%
	(SF)	(Acres)	C2	C5	C10	C25	C50	C100	Imperv.
Forest	28,016	0.64	0.02	0.08	0.15	0.25	0.3	0.35	0%
Combined	28,016	0.64	0.02	0.08	0.15	0.25	0.30	0.35	0.0%

28016

Basin Travel Time

Shallow Channel Ground Cover Forest

	$L_{max,Overland}$	ΔZ_0	S_0	v	t	t_{ait}	
	(ft)	(ft)	(ft/ft)	(ft/s)	(min)	(min)	
Total	221	21	-	-	-	-	
Initial Time	81	11	0.136	-	7.0	-	N/A DCM Eq. 6-8
Shallow Channel	140	10	0.071	1.3	1.7	-	- DCM Eq. 6-9
Channelized			0.000	0.0	0.0	-	- V-Ditch
				t_c			8.8 min.

Rainfall Intensity & Runoff

	2-Yr	5-Yr	10-Yr	25-Yr	50-Yr	100-Yr
Intensity (in/hr)	3.45	4.33	5.05	5.77	6.49	7.27
Runoff (cfs)	0.0	0.2	0.5	0.9	1.3	1.6
Release Rates (cfs/ac)	-	-	-	-	-	-
Allowed Release (cfs)	0.0	0.2	0.5	0.9	1.3	1.6

DCM: $t = C1 * \ln(tc) + C2$

C1	1.19	1.5	1.75	2	2.25	2.52
C2	6.035	7.583	8.847	10.111	11.375	12.735

Notes

Sub-Basin C5 Runoff Calculations

Job No.: 61087 Date: 9/16/2019 10:38
 Project: Sanctuary of Peace Calcs by: ASM
 Checked by: _____
 Jurisdiction: DCM Soil Type: B
 Runoff Coefficient: Surface Type Urbanization: Non-Urban

Basin Land Use Characteristics

Surface	Area		Runoff Coefficient						% Imperv.
	(SF)	(Acres)	C2	C5	C10	C25	C50	C100	
Forest	70,265	1.61	0.02	0.08	0.15	0.25	0.3	0.35	0%
Combined	70,265	1.61	0.02	0.08	0.15	0.25	0.30	0.35	0.0%

Basin Travel Time

Shallow Channel Ground Cover Forest

	$L_{max,Overland}$	ΔZ_0	S_0	v	t	t_{Alt}	
	(ft)	(ft)	(ft/ft)	(ft/s)	(min)	(min)	
Total	223	18	-	-	-	-	
Initial Time	100	10	0.100	-	8.6	N/A	DCM Eq. 6-8
Shallow Channel	123	8	0.065	1.3	1.6	-	DCM Eq. 6-9
Channelized			0.000	0.0	0.0	-	V-Ditch
				t_c	10.2 min.		

Rainfall Intensity & Runoff

	2-Yr	5-Yr	10-Yr	25-Yr	50-Yr	100-Yr
Intensity (in/hr)	3.27	4.10	4.78	5.46	6.14	6.88
Runoff (cfs)	0.1	0.5	1.2	2.2	3.0	3.9
Release Rates (cfs/ac)	-	-	-	-	-	-
Allowed Release (cfs)	0.1	0.5	1.2	2.2	3.0	3.9

DCM: $t = C1 * \ln(tc) + C2$

C1	1.19	1.5	1.75	2	2.25	2.52
C2	6.035	7.583	8.847	10.111	11.375	12.735

Notes

M.V.E., Inc.
1903 Lelaray Street., Suite 200
Colorado Springs, CO 80909
(719) 635-5736

JOB 601087 - SANCTUARY OF PEACE

SHEET NO. 1 OF 1

CALCULATED BY CC Cur DATE 9-16-19

CHECKED BY _____ DATE _____

SCALE _____

EX 1

COMBINED BASINS
OSA, OSB, EX-A1

	Q_5	Q_{100}
OSA	11.4 cfs	51.1 cfs
OSB	17.4	102.7
EX-A1	6.9	50.6
	<hr/>	<hr/>
Q_5	35.7 cfs	204.4

Combined Sub-Basin EX4 Runoff Calculations

Includes Basins EX-C2

Job No.:	61087	Date:	9/16/2019 10:38
Project:	Sanctuary of Peace	Calcs by:	ASM
Jurisdiction:	DCM	Checked by:	
Runoff Coefficient	Surface Type	Soil Type	B
		Urbanization	Non-Urban

Basin Land Use Characteristics

Surface	Area		Runoff Coefficient							% Imperv.
	(SF)	(Acres)	C2	C5	C10	C25	C50	C100		
Forest	88,571	2.03	0.02	0.08	0.15	0.25	0.3	0.35	0%	
Combined	88,571	2.03	0.02	0.08	0.15	0.25	0.30	0.35	0.0%	

Basin Travel Time

	Sub-basin or Channel Type	Material Type	L (ft)	Elev. ΔZ ₀ (ft)	Q _i (cfs)	Base or Dia (ft)	Sides z:1 (ft/ft)	v (ft/s)	t (min)
Furthest Reach	EX-C2	-	300	25	-	-	-	-	10.9
Channelized-1									
Channelized-2									
Channelized-3									
Total			300	25					
								t_c	10.9
								(min)	

Contributing Offsite Flows (Added to Runoff and Allowed Release, below.)

Contributing Basins/Areas

Q _{Minor}	(cfs) - 5-year Storm
Q _{Major}	(cfs) - 100-year Storm

Rainfall Intensity & Runoff

	2-Yr	5-Yr	10-Yr	25-Yr	50-Yr	100-Yr
Intensity (in/hr)	3.19	4.00	4.67	5.33	6.00	6.71
Site Runoff (cfs)	0.13	0.65	1.42	2.71	3.66	4.78
OffSite Runoff (cfs)	-	0.00	-	-	-	0.00
Release Rates (cfs/ac)	-	-	-	-	-	-
Allowed Release (cfs)	-	0.7	-	-	-	4.8

DCM: $I = C1 * \ln(tc) + C2$

C1	1.19	1.5	1.75	2	2.25	2.52
C2	6.035	7.583	8.847	10.111	11.375	12.735

Notes

Runoff from Offsite basins have been assumed constant, despite additional times of concentration.

Combined Sub-Basin EX5 Runoff Calculations

Includes Basins EX-C3

Job No.:	<u>61087</u>	Date:	<u>9/16/2019 10:38</u>
Project:	<u>Sanctuary of Peace</u>	Calcs by:	<u>ASM</u>
Jurisdiction	<u>DCM</u>	Checked by:	
Runoff Coefficient	<u>Surface Type</u>	Soil Type	<u>B</u>
		Urbanization	<u>Non-Urban</u>

Basin Land Use Characteristics

Surface	Area		Runoff Coefficient							% Imperv.
	(SF)	(Acres)	C2	C5	C10	C25	C50	C100		
Forest	28,874	0.66	0.02	0.08	0.15	0.25	0.3	0.35	0%	
Combined	28,874	0.66	0.02	0.08	0.15	0.25	0.30	0.35	0.0%	

Basin Travel Time

	Sub-basin or Channel Type	Material Type	L (ft)	Elev. ΔZ_0 (ft)	Q_i (cfs)	Base or Dia (ft)	Sides z:1 (ft/ft)	v (ft/s)	t (min)
Furthest Reach	EX-C3	-	217	17	-	-	-	-	9.8
Channelized-1									
Channelized-2									
Channelized-3									
Total			217	17					
								t_c (min)	9.8

Contributing Offsite Flows (Added to Runoff and Allowed Release, below.)

Contributing Basins/Areas

Q_{Minor}	(cfs) - 5-year Storm
Q_{Major}	(cfs) - 100-year Storm

Rainfall Intensity & Runoff

	2-Yr	5-Yr	10-Yr	25-Yr	50-Yr	100-Yr
Intensity (in/hr)	3.32	4.17	4.86	5.56	6.25	7.00
Site Runoff (cfs)	0.04	0.22	0.48	0.92	1.24	1.62
OffSite Runoff (cfs)	-	0.00	-	-	-	0.00
Release Rates (cfs/ac)	-	-	-	-	-	-
Allowed Release (cfs)	-	0.2	-	-	-	1.6

DCM: $I = C1 * \ln(tc) + C2$

C1	1.19	1.5	1.75	2	2.25	2.52
C2	6.036	7.583	8.847	10.111	11.375	12.735

Notes

Runoff from Offsite basins have been assumed constant, despite additional times of concentration.

Combined Sub-Basin EX7 Runoff Calculations

Includes Basins EX-C1

Job No.:	61087	Date:	9/16/2019 10:38
Project:	Sanctuary of Peace	Calcs by:	ASM
Jurisdiction	DCM	Checked by:	
Runoff Coefficient	Surface Type	Soil Type	B
		Urbanization	Non-Urban

Basin Land Use Characteristics

Surface	Area		Runoff Coefficient						% Imperv.
	(SF)	(Acres)	C2	C5	C10	C25	C50	C100	
Forest	247,407	5.68	0.02	0.08	0.15	0.25	0.3	0.35	0%
Combined	247,407	5.68	0.02	0.08	0.15	0.25	0.30	0.35	0.0%

Basin Travel Time

	Sub-basin or Channel Type	Material Type	L (ft)	Elev. ΔZ ₀ (ft)	Q _i (cfs)	Base or Dia (ft)	Sides z:1 (ft/ft)	v (ft/s)	t (min)
Furthest Reach	EX-C1	-	722	36	-	-	-	-	15.7
Channelized-1									
Channelized-2									
Channelized-3									
Total			722	36					
							t_c		15.7
							(min)		

Contributing Offsite Flows (Added to Runoff and Allowed Release, below.)

Contributing Basins/Areas

Q _{Minor}	(cfs) - 5-year Storm
Q _{Major}	(cfs) - 100-year Storm

Rainfall Intensity & Runoff

	2-Yr	5-Yr	10-Yr	25-Yr	50-Yr	100-Yr
Intensity (in/hr)	2.76	3.45	4.02	4.60	5.17	5.79
Site Runoff (cfs)	0.31	1.57	3.43	6.53	8.82	11.51
OffSite Runoff (cfs)	-	0.00	-	-	-	0.00
Release Rates (cfs/ac)	-	-	-	-	-	-
Allowed Release (cfs)	-	1.6	-	-	-	11.5

DCM: I = C1 * ln(tc) + C2

C1	1.19	1.5	1.75	2	2.25	2.52
C2	6.035	7.583	8.847	10.111	11.375	12.736

Notes

Runoff from Offsite basins have been assumed constant, despite additional times of concentration.

Combined Sub-Basin EX8 Runoff Calculations

Includes Basins EX-B1

Job No.:	<u>61087</u>	Date:	<u>9/16/2019 10:38</u>
Project:	<u>Sanctuary of Peace</u>	Calcs by:	<u>ASM</u>
Jurisdiction	<u>DCM</u>	Checked by:	
Runoff Coefficient	<u>Surface Type</u>	Soil Type	<u>B</u>
		Urbanization	<u>Non-Urban</u>

Basin Land Use Characteristics

Surface	Area		Runoff Coefficient						% Imperv.
	(SF)	(Acres)	C2	C5	C10	C25	C50	C100	
Forest	89,528	2.06	0.02	0.08	0.15	0.25	0.3	0.35	0%
Combined	89,528	2.06	0.02	0.08	0.15	0.25	0.30	0.35	0.0%

Basin Travel Time

	Sub-basin or Channel Type	Material Type	L (ft)	Elev. ΔZ_0 (ft)	Q_i (cfs)	Base or Dia (ft)	Sides z:1 (ft/ft)	v (ft/s)	t (min)
Furthest Reach	EX-A1	-	1,700	121	-	-	-	-	23.3
Channelized-1									
Channelized-2									
Channelized-3									
Total			1,700	121					
								t_c (min)	23.3

Contributing Offsite Flows (Added to Runoff and Allowed Release, below.)

Contributing Basins/Areas

Q_{Minor} (cfs) - 5-year Storm

Q_{Major} (cfs) - 100-year Storm

Rainfall Intensity & Runoff

	2-Yr	5-Yr	10-Yr	25-Yr	50-Yr	100-Yr
Intensity (in/hr)	2.29	2.86	3.34	3.82	4.30	4.81
Site Runoff (cfs)	0.09	0.47	1.03	1.96	2.65	3.46
OffSite Runoff (cfs)	-	0.00	-	-	-	0.00
Release Rates (cfs/ac)	-	-	-	-	-	-
Allowed Release (cfs)	-	0.5	-	-	-	3.5

DCM: $I = C1 * \ln(tc) + C2$

C1	1.19	1.5	1.75	2	2.25	2.52
C2	6.035	7.583	8.847	10.111	11.375	12.735

Notes

Runoff from Offsite basins have been assumed constant, despite additional times of concentration.

Combined Sub-Basin EX9 Runoff Calculations

Includes Basins OS C EX-B1 EX-B2

Job No.:	61087	Date:	9/16/2019 10:38
Project:	Sanctuary of Peace	Calcs by:	ASM
Jurisdiction	DCM	Checked by:	
Runoff Coefficient	Surface Type	Soil Type	B
		Urbanization	Non-Urban

Basin Land Use Characteristics

Surface	Area		Runoff Coefficient						% Imperv.
	(SF)	(Acres)	C2	C5	C10	C25	C50	C100	
Forest	2,494,099	57.26	0.02	0.08	0.15	0.25	0.3	0.35	0%
Gravel	29,852	0.69	0.57	0.59	0.63	0.66	0.68	0.7	80%
Driveways & Walks	76,619	1.76	0.89	0.9	0.92	0.94	0.95	0.96	100%
Roofs	9,943	0.23	0.71	0.73	0.75	0.78	0.8	0.81	90%
Combined	2,610,513	59.93	0.05	0.11	0.18	0.28	0.33	0.37	4.2%

Basin Travel Time

	Sub-basin or Channel Type	Material Type	L (ft)	Elev. ΔZ_0 (ft)	Q_i (cfs)	Base or Dia (ft)	Sides z:1 (ft/ft)	v (ft/s)	t (min)
Furthest Reach	OS C	-	1,692	129	-	-	-	-	23.9
Channelized-1			0	0					
Channelized-2									
Channelized-3									
Total			1,692	129					
								t_c (min)	23.9

Contributing Offsite Flows (Added to Runoff and Allowed Release, below.)

Contributing Basins/Areas

Q_{Minor} (cfs) - 5-year Storm
 Q_{Major} (cfs) - 100-year Storm

Rainfall Intensity & Runoff

	2-Yr	5-Yr	10-Yr	25-Yr	50-Yr	100-Yr
Intensity (in/hr)	2.26	2.82	3.29	3.76	4.23	4.73
Site Runoff (cfs)	7.37	19.00	35.58	62.44	82.51	106.03
OffSite Runoff (cfs)	-	0.00	-	-	-	0.00
Release Rates (cfs/ac)	-	-	-	-	-	-
Allowed Release (cfs)	-	19.0	-	-	-	106.0

$$DCM-1 = C1 * \ln(tc) + C2$$

C1	1.19	1.5	1.75	2	2.25	2.52
C2	6.035	7.583	8.847	10.111	11.375	12.735

Notes

Runoff from Offsite basins have been assumed constant, despite additional times of concentration.

M.V.E., Inc.
1903 Lelary Street., Suite 200
Colorado Springs, CO 80909
(719) 635-5736

JOB 61087- SANCTUARY OF PEACE

SHEET NO. 1 OF 1

CALCULATED BY A.C. Cur DATE 9-16-19

CHECKED BY _____ DATE _____

SCALE _____

DP 1

Cornered BASINS

DP2, A2, OSA, & OSB

	Q_5	Q_{100}
DP2-Out	0.1 cfs	3.1 cfs

A2	5.9	43.3
----	-----	------

OSA	11.4	81.1
-----	------	------

OSB	17.4	102.7
-----	------	-------

$Q_5 = 34.8$ cfs $Q_{100} = 230.2$ cfs

Combined Sub-Basin DP2 Runoff Calculations

Includes Basins A1

Job No.:	<u>61087</u>	Date:	<u>9/16/2019 10:38</u>
Project:	<u>Sanctuary of Peace</u>	Calcs by:	<u>ASM</u>
Jurisdiction	<u>DCM</u>	Checked by:	
Runoff Coefficient	<u>Surface Type</u>	Soil Type	<u>B</u>
		Urbanization	<u>Non-Urban</u>

Basin Land Use Characteristics

Surface	Area		Runoff Coefficient						% Imperv.
	(SF)	(Acres)	C2	C5	C10	C25	C50	C100	
Forest	50,438	1.16	0.02	0.08	0.15	0.25	0.3	0.35	0%
Gravel	-	0.00	0.57	0.59	0.63	0.66	0.68	0.7	80%
Driveways & Walks	16,558	0.38	0.89	0.9	0.92	0.94	0.95	0.96	100%
Roofs	13,532	0.31	0.71	0.73	0.75	0.78	0.8	0.81	90%
Combined	80,528	1.85	0.31	0.36	0.41	0.48	0.52	0.55	35.7%

Basin Travel Time

	Sub-basin or Channel Type	Material Type	L (ft)	Elev. ΔZ ₀ (ft)	Q _i (cfs)	Base or Dia (ft)	Sides z:1 (ft/ft)	v (ft/s)	t (min)
Furthest Reach	A1	-	317	23	-	-	-	-	9.1
Channelized-1		2	0	0					
Channelized-2									
Channelized-3									
Total			317	23					

2 = Natural, Winding, minimal vegetation/shallow grass

t_c (min) 9.1

Contributing Offsite Flows (Added to Runoff and Allowed Release, below.)

Contributing Basins/Areas

Q_{Minor} (cfs) - 5-year Storm
 Q_{Major} (cfs) - 100-year Storm

Rainfall Intensity & Runoff

	2-Yr	5-Yr	10-Yr	25-Yr	50-Yr	100-Yr
Intensity (in/hr)	3.40	4.26	4.97	5.68	6.39	7.16
Site Runoff (cfs)	1.98	2.82	3.76	5.05	6.12	7.31
OffSite Runoff (cfs)	-	0.00	-	-	-	0.00
Release Rates (cfs/ac)	-	-	-	-	-	-
Allowed Release (cfs)	-	2.8	-	-	-	7.3

DCM: $I = C1 * \ln(tc) + C2$

C1	1.19	1.5	1.75	2	2.25	2.52
C2	6.035	7.583	8.847	10.111	11.375	12.735

Notes

Runoff from Offsite basins have been assumed constant, despite additional times of concentration.

Combined Sub-Basin DP3 Runoff Calculations

Includes Basins C2

Job No.:	<u>61087</u>	Date:	<u>9/16/2019 10:38</u>
Project:	<u>Sanctuary of Peace</u>	Calcs by:	<u>ASM</u>
Jurisdiction	<u>DCM</u>	Checked by:	
Runoff Coefficient	<u>Surface Type</u>	Soil Type	<u>B</u>
		Urbanization	<u>Non-Urban</u>

Basin Land Use Characteristics

Surface	Area		Runoff Coefficient						% Imperv.
	(SF)	(Acres)	C2	C5	C10	C25	C50	C100	
Forest	20,454	0.47	0.02	0.08	0.15	0.25	0.3	0.35	0%
Gravel	-	0.00	0.57	0.59	0.63	0.66	0.68	0.7	80%
Driveways & Walks	1,280	0.03	0.89	0.9	0.92	0.94	0.95	0.96	100%
Roofs	7,150	0.16	0.71	0.73	0.75	0.78	0.8	0.81	90%
Combined	28,884	0.66	0.23	0.28	0.33	0.41	0.45	0.49	26.7%

Basin Travel Time

	Sub-basin or Channel Type	Material Type	L (ft)	Elev. ΔZ_0 (ft)	Q_i (cfs)	Base or Dia (ft)	Sides z:1 (ft/ft)	v (ft/s)	t (min)
Furthest Reach	C2	-	189	12	-	-	-	-	8.8
Channelized-1		2	0	0					
Channelized-2									
Channelized-3									
Total			189	12					

2 = Natural, Winding, minimal vegetation/shallow grass

t_c (min) **8.8**

Contributing Offsite Flows (Added to Runoff and Allowed Release, below.)

Contributing Basins/Areas

Q_{Minor} (cfs) - 5-year Storm
 Q_{Major} (cfs) - 100-year Storm

Rainfall Intensity & Runoff

	2-Yr	5-Yr	10-Yr	25-Yr	50-Yr	100-Yr
Intensity (in/hr)	3.44	4.32	5.04	5.76	6.48	7.25
Site Runoff (cfs)	0.52	0.79	1.11	1.57	1.94	2.36
OffSite Runoff (cfs)	-	0.00	-	-	-	0.00
Release Rates (cfs/ac)	-	-	-	-	-	-
Allowed Release (cfs)	-	0.8	-	-	-	2.4

DCM: $I = C1 * \ln(t_c) + C2$

C1	1.19	1.6	1.75	2	2.25	2.52
C2	6.036	7.583	8.847	10.111	11.375	12.736

Notes

Runoff from Offsite basins have been assumed constant, despite additional times of concentration.

Combined Sub-Basin DP4 Runoff Calculations

Includes Basins C3

Job No.: 61087

Date: 9/16/2019 10:38

Project: Sanctuary of Peace

Calcs by: ASM

Jurisdiction: DCM
Runoff Coefficient: Surface Type

Checked by: _____
Soil Type: B
Urbanization: Non-Urban

Basin Land Use Characteristics

Surface	Area		Runoff Coefficient						% Imperv.
	(SF)	(Acres)	C2	C5	C10	C25	C50	C100	
Forest	59,267	1.36	0.02	0.08	0.15	0.25	0.3	0.35	0%
Gravel	-	0.00	0.57	0.59	0.63	0.66	0.68	0.7	80%
Driveways & Walks	-	0.00	0.89	0.9	0.92	0.94	0.95	0.96	100%
Roofs	-	0.00	0.71	0.73	0.75	0.78	0.8	0.81	90%
Combined	59,267	1.36	0.02	0.08	0.15	0.25	0.30	0.35	0.0%

Basin Travel Time

	Sub-basin or Channel Type	Material Type	L (ft)	Elev. ΔZ ₀ (ft)	Q _i (cfs)	Base or Dia (ft)	Sides z:1 (ft/ft)	v (ft/s)	t (min)
Furthest Reach	C3	-	273	20	-	-	-	-	11.8
Channelized-1				0					
Channelized-2									
Channelized-3									
Total			273	20					
								t_c (min)	11.8

Contributing Offsite Flows (Added to Runoff and Allowed Release, below.)

Contributing Basins/Areas DP3 / Pond C2 Outflow

Q_{Minor} 0 (cfs) - 5-year Storm
Q_{Major} 1.1 (cfs) - 100-year Storm

Rainfall Intensity & Runoff

	2-Yr	5-Yr	10-Yr	25-Yr	50-Yr	100-Yr
Intensity (in/hr)	3.10	3.88	4.53	5.18	5.82	6.52
Site Runoff (cfs)	0.08	0.42	0.92	1.76	2.38	3.10
OffSite Runoff (cfs)	-	0.00	-	-	-	1.10
Release Rates (cfs/ac)	-	-	-	-	-	-
Allowed Release (cfs)	-	0.4	-	-	-	4.2

$$DCM: 1 = C1 * \ln(tc) + C2$$

C1 1.19 1.5 1.75 2 2.25 2.52
C2 6.035 7.583 8.647 10.111 11.375 12.735

Notes

Runoff from Offsite basins have been assumed constant, despite additional times of concentration.

Combined Sub-Basin DP5 Runoff Calculations

Includes Basins C4

Job No.:	<u>61087</u>	Date:	<u>9/16/2019 10:38</u>
Project:	<u>Sanctuary of Peace</u>	Calcs by:	<u>ASM</u>
Jurisdiction	<u>DCM</u>	Checked by:	
Runoff Coefficient	<u>Surface Type</u>	Soil Type	<u>B</u>
		Urbanization	<u>Non-Urban</u>

Basin Land Use Characteristics

Surface	Area		Runoff Coefficient						% Imperv.
	(SF)	(Acres)	C2	C5	C10	C25	C50	C100	
Forest	28,016	0.64	0.02	0.08	0.15	0.25	0.3	0.35	0%
Gravel	-	0.00	0.57	0.59	0.63	0.66	0.68	0.7	80%
Driveways & Walks	-	0.00	0.89	0.9	0.92	0.94	0.95	0.96	100%
Roofs	-	0.00	0.71	0.73	0.75	0.78	0.8	0.81	90%
Combined	28,016	0.64	0.02	0.08	0.15	0.25	0.30	0.35	0.0%

Basin Travel Time

	Sub-basin or Channel Type	Material Type	L (ft)	Elev. ΔZ_0 (ft)	Q_i (cfs)	Base or Dia (ft)	Sides z:1 (ft/ft)	v (ft/s)	t (min)
Furthest Reach	C4	-	221	21	-	-	-	-	8.8
Channelized-1		2	0	0					
Channelized-2				0					
Channelized-3									
Total			221	21					

2 = Natural, Winding, minimal vegetation/shallow grass

t_c (min) **8.8**

Contributing Offsite Flows (Added to Runoff and Allowed Release, below.)

Contributing Basins/Areas _____

Q_{Minor} _____ (cfs) - 5-year Storm

Q_{Major} _____ (cfs) - 100-year Storm

Rainfall Intensity & Runoff

	2-Yr	5-Yr	10-Yr	25-Yr	50-Yr	100-Yr
Intensity (in/hr)	3.45	4.33	5.05	5.77	6.49	7.27
Site Runoff (cfs)	0.04	0.22	0.49	0.93	1.25	1.64
OffSite Runoff (cfs)	-	0.00	-	-	-	0.00
Release Rates (cfs/ac)	-	-	-	-	-	-
Allowed Release (cfs)	-	0.2	-	-	-	1.6

DCM: $I = C1 * \ln(tc) + C2$

C1	1.19	1.5	1.75	2	2.25	2.52
C2	6.035	7.583	8.847	10.111	11.375	12.735

Notes

Runoff from Offsite basins have been assumed constant, despite additional times of concentration.

Combined Sub-Basin DP6 Runoff Calculations

Includes Basins C1

Job No.:	<u>61087</u>	Date:	<u>9/16/2019 10:38</u>
Project:	<u>Sanctuary of Peace</u>	Calcs by:	<u>ASM</u>
Jurisdiction	<u>DCM</u>	Checked by:	
Runoff Coefficient	<u>Surface Type</u>	Soil Type	<u>B</u>
		Urbanization	<u>Non-Urban</u>

Basin Land Use Characteristics

Surface	Area		Runoff Coefficient						% Imperv.
	(SF)	(Acres)	C2	C5	C10	C25	C50	C100	
Forest	130,377	2.99	0.02	0.08	0.15	0.25	0.3	0.35	0%
Gravel	-	0.00	0.57	0.59	0.63	0.66	0.68	0.7	80%
Driveways & Walks	20,192	0.46	0.89	0.9	0.92	0.94	0.95	0.96	100%
Roofs	26,845	0.62	0.71	0.73	0.75	0.78	0.8	0.81	90%
Combined	177,414	4.07	0.22	0.27	0.33	0.41	0.45	0.49	25.0%

Basin Travel Time

	Sub-basin or Channel Type	Material Type	L (ft)	Elev. ΔZ_0 (ft)	Q_i (cfs)	Base or Dia (ft)	Sides z:1 (ft/ft)	v (ft/s)	t (min)
Furthest Reach	C1	-	557	37	-	-	-	-	13.1
Channelized-1		2	0	0					
Channelized-2									
Channelized-3									
Total			557	37					

2 = Natural, Winding, minimal vegetation/shallow grass

t_c (min) **13.1**

Contributing Offsite Flows (Added to Runoff and Allowed Release, below.)

Contributing Basins/Areas

Q_{Minor} (cfs) - 5-year Storm

Q_{Major} (cfs) - 100-year Storm

Rainfall Intensity & Runoff

	2-Yr	5-Yr	10-Yr	25-Yr	50-Yr	100-Yr
Intensity (in/hr)	2.97	3.72	4.35	4.97	5.59	6.25
Site Runoff (cfs)	2.71	4.12	5.81	8.27	10.23	12.45
OffSite Runoff (cfs)	-	0.00	-	-	-	0.00
Release Rates (cfs/ac)	-	-	-	-	-	-
Allowed Release (cfs)	-	4.1	-	-	-	12.5

$$DCM: I = C1 * \ln(Ic) + C2$$

C1	1.19	1.5	1.75	2	2.25	2.52
C2	6.036	7.583	8.847	10.111	11.375	12.735

Notes

Runoff from Offsite basins have been assumed constant, despite additional times of concentration.

Combined Sub-Basin DP7 Runoff Calculations

Includes Basins C5

Job No.:	<u>61087</u>	Date:	<u>9/16/2019 10:38</u>
Project:	<u>Sanctuary of Peace</u>	Calcs by:	<u>ASM</u>
Jurisdiction	<u>DCM</u>	Checked by:	
Runoff Coefficient	<u>Surface Type</u>	Soil Type	<u>B</u>
		Urbanization	<u>Non-Urban</u>

Basin Land Use Characteristics

Surface	Area		Runoff Coefficient						% Imperv.
	(SF)	(Acres)	C2	C5	C10	C25	C50	C100	
Forest	70,265	1.61	0.02	0.08	0.15	0.25	0.3	0.35	0%
Gravel	-	0.00	0.57	0.59	0.63	0.66	0.68	0.7	80%
Driveways & Walks	-	0.00	0.89	0.9	0.92	0.94	0.95	0.96	100%
Roofs	-	0.00	0.71	0.73	0.75	0.78	0.8	0.81	90%
Combined	70,265	1.61	0.02	0.08	0.15	0.25	0.30	0.35	0.0%

Basin Travel Time

	Sub-basin or Channel Type	Material Type	L (ft)	Elev. ΔZ ₀ (ft)	Q _i (cfs)	Base or Dia (ft)	Sides z:1 (ft/ft)	v (ft/s)	t (min)
Furthest Reach	C5	-	223	18	-	-	-	-	10.2
Channelized-1		2	0	0					
Channelized-2									
Channelized-3									
Total			223	18					

2 = Natural, Winding, minimal vegetation/shallow grass

t_c (min) 10.2

Contributing Offsite Flows (Added to Runoff and Allowed Release, below.)

Contributing Basins/Areas DP6 / Pond C1 Outflow

Q_{Minor} 0.1 (cfs) - 5-year Storm
 Q_{Major} 6.1 (cfs) - 100-year Storm

Rainfall Intensity & Runoff

	2-Yr	5-Yr	10-Yr	25-Yr	50-Yr	100-Yr
Intensity (in/hr)	3.27	4.10	4.78	5.46	6.14	6.88
Site Runoff (cfs)	0.11	0.53	1.16	2.20	2.97	3.88
OffSite Runoff (cfs)	-	0.10	-	-	-	6.10
Release Rates (cfs/ac)	-	-	-	-	-	-
Allowed Release (cfs)	-	0.6	-	-	-	10.0

DCM: I = C1 * ln(tc) + C2

C1	1.19	1.5	1.75	2	2.25	2.52
C2	6.035	7.583	8.847	10.111	11.375	12.735

Notes

Runoff from Offsite basins have been assumed constant, despite additional times of concentration.

Combined Sub-Basin DP8 Runoff Calculations

Includes Basins B1

Job No.:	<u>61087</u>	Date:	<u>9/16/2019 10:38</u>
Project:	<u>Sanctuary of Peace</u>	Calcs by:	<u>ASM</u>
Jurisdiction	<u>DCM</u>	Checked by:	
Runoff Coefficient	<u>Surface Type</u>	Soil Type	<u>B</u>
		Urbanization	<u>Non-Urban</u>

Basin Land Use Characteristics

Surface	Area		Runoff Coefficient						% Imperv.
	(SF)	(Acres)	C2	C5	C10	C25	C50	C100	
Forest	102,701	2.36	0.02	0.08	0.15	0.25	0.3	0.35	0%
Gravel	-	0.00	0.57	0.59	0.63	0.66	0.68	0.7	80%
Driveways & Walks	-	0.00	0.89	0.9	0.92	0.94	0.95	0.96	100%
Roofs	-	0.00	0.71	0.73	0.75	0.78	0.8	0.81	90%
Combined	102,701	2.36	0.02	0.08	0.15	0.25	0.30	0.35	0.0%

Basin Travel Time

	Sub-basin or Channel Type	Material Type	L (ft)	Elev. ΔZ_0 (ft)	Q_i (cfs)	Base or Dia (ft)	Sides z:1 (ft/ft)	v (ft/s)	t (min)
Furthest Reach	B1	-	567	30	-	-	-	-	14.4
Channelized-1				0					
Channelized-2									
Channelized-3									
Total			567	30					
								t_c (min)	14.4

Contributing Offsite Flows (Added to Runoff and Allowed Release, below.)

Contributing Basins/Areas

Q_{Minor} (cfs) - 5-year Storm
 Q_{Major} (cfs) - 100-year Storm

Rainfall Intensity & Runoff

	2-Yr	5-Yr	10-Yr	25-Yr	50-Yr	100-Yr
Intensity (in/hr)	2.86	3.59	4.18	4.78	5.38	6.02
Site Runoff (cfs)	0.14	0.68	1.48	2.82	3.81	4.97
OffSite Runoff (cfs)	-	0.00	-	-	-	0.00
Release Rates (cfs/ac)	-	-	-	-	-	-
Allowed Release (cfs)	-	0.7	-	-	-	5.0

DCM: $I = C1 * \ln(tc) + C2$

C1	1.19	1.5	1.75	2	2.25	2.52
C2	6.035	7.583	8.847	10.111	11.375	12.735

Notes

Runoff from Offsite basins have been assumed constant, despite additional times of concentration.

Combined Sub-Basin DP9 Runoff Calculations

Includes Basins B1 B2 OS C

Job No.:	61087	Date:	9/16/2019 10:38
Project:	Sanctuary of Peace	Calcs by:	ASM
Jurisdiction	DCM	Checked by:	
Runoff Coefficient	Surface Type	Soil Type	B
		Urbanization	Non-Urban

Basin Land Use Characteristics

Surface	Area		Runoff Coefficient							% Imperv.
	(SF)	(Acres)	C2	C5	C10	C25	C50	C100		
Forest	2,520,607	57.87	0.02	0.08	0.15	0.25	0.3	0.35	0%	
Gravel	29,852	0.69	0.57	0.59	0.63	0.66	0.68	0.7	80%	
Driveways & Walks	84,402	1.94	0.89	0.9	0.92	0.94	0.95	0.96	100%	
Roofs	9,943	0.23	0.71	0.73	0.75	0.78	0.8	0.81	90%	
Combined	2,644,804	60.72	0.06	0.11	0.18	0.28	0.33	0.38	4.4%	

Basin Travel Time

	Sub-basin or Channel Type	Material Type	L (ft)	Elev. ΔZ ₀ (ft)	Q _i (cfs)	Base or Dia (ft)	Sides z:1 (ft/ft)	v (ft/s)	t (min)
Furthest Reach	B1	-	567	30	-	-	-	-	14.4
Channelized-1			0	0					
Channelized-2									
Channelized-3									
Total			567	30					
								t_c (min)	14.4

Contributing Offsite Flows (Added to Runoff and Allowed Release, below.)

Contributing Basins/Areas

Q _{Minor}	
Q _{Major}	(cfs) - 5-year Storm
	(cfs) - 100-year Storm

Rainfall Intensity & Runoff

	2-Yr	5-Yr	10-Yr	25-Yr	50-Yr	100-Yr
Intensity (in/hr)	2.86	3.59	4.18	4.78	5.38	6.02
Site Runoff (cfs)	9.84	24.91	46.31	80.92	106.80	137.16
OffSite Runoff (cfs)	-	0.00	-	-	-	0.00
Release Rates (cfs/ac)	-	-	-	-	-	-
Allowed Release (cfs)	-	24.9	-	-	-	137.2

DCM: $I = C1 * \ln(tc) + C2$

C1	1.19	1.5	1.75	2	2.25	2.52
C2	6.036	7.583	8.847	10.111	11.375	12.735

Notes

Runoff from Offsite basins have been assumed constant, despite additional times of concentration.

3 Hydraulic Calculations

IRF Worksheet

FS EDB design calculations (UD-BMP)

FS EDB design calculations (UD-Detention)

Spillway Detail

Culvert Calculations

Design Procedure Form: Sand Filter (SF)

UD-BMP (Version 3.07, March 2018)

Sheet 1 of 2

Designer: D. Gorman
Company: M.V.E., Inc.
Date: September 13, 2019
Project: Sanctuary of Peace
Location: Sub-basin A1 - Sand Filter

<p>1. Basin Storage Volume</p> <p>A) Effective Imperviousness of Tributary Area, I_a (100% if all paved and roofed areas upstream of sand filter)</p> <p>B) Tributary Area's Imperviousness Ratio ($i = I_a/100$)</p> <p>C) Water Quality Capture Volume (WQCV) Based on 12-hour Drain Time $WQCV = 0.8 * (0.91 * i^3 - 1.19 * i^2 + 0.78 * i)$</p> <p>D) Contributing Watershed Area (including sand filter area)</p> <p>E) Water Quality Capture Volume (WQCV) Design Volume $V_{WQCV} = WQCV / 12 * Area$</p> <p>F) For Watersheds Outside of the Denver Region, Depth of Average Runoff Producing Storm</p> <p>G) For Watersheds Outside of the Denver Region, Water Quality Capture Volume (WQCV) Design Volume</p> <p>H) User Input of Water Quality Capture Volume (WQCV) Design Volume (Only if a different WQCV Design Volume is desired)</p>	<p>$I_a =$ <input type="text" value="35.7"/> %</p> <p>$i =$ <input type="text" value="0.357"/></p> <p>WQCV = <input type="text" value="0.13"/> watershed inches</p> <p>Area = <input type="text" value="80,528"/> sq ft</p> <p>$V_{WQCV} =$ <input type="text" value=""/> cu ft</p> <p>$d_a =$ <input type="text" value="0.42"/> in</p> <p>$V_{WQCV \text{ OTHER}} =$ <input type="text" value="882"/> cu ft</p> <p>$V_{WQCV \text{ USER}} =$ <input type="text" value=""/> cu ft</p>
<p>2. Basin Geometry</p> <p>A) WQCV Depth</p> <p>B) Sand Filter Side Slopes (Horizontal distance per unit vertical, 4:1 or flatter preferred). Use "0" if sand filter has vertical walls.</p> <p>C) Minimum Filter Area (Flat Surface Area)</p> <p>D) Actual Filter Area</p> <p>E) Volume Provided</p>	<p>$D_{WQCV} =$ <input type="text" value="0.7"/> ft</p> <p>$Z =$ <input type="text" value="3.00"/> ft / ft DIFFICULT TO MAINTAIN, INCREASE WHERE POSSIBLE</p> <p>$A_{Min} =$ <input type="text" value="359"/> sq ft</p> <p>$A_{Actual} =$ <input type="text" value="1200"/> sq ft</p> <p>$V_T =$ <input type="text" value="5990"/> cu ft</p>
<p>3. Filter Material</p>	<p>Choose One _____</p> <p><input checked="" type="radio"/> 18" CDOT Class B or C Filter Material</p> <p><input type="radio"/> Other (Explain): _____</p>
<p>4. Underdrain System</p> <p>A) Are underdrains provided?</p> <p>B) Underdrain system orifice diameter for 12 hour drain time</p> <p style="margin-left: 20px;">i) Distance From Lowest Elevation of the Storage Volume to the Center of the Orifice</p> <p style="margin-left: 20px;">ii) Volume to Drain in 12 Hours</p> <p style="margin-left: 20px;">iii) Orifice Diameter, 3/8" Minimum</p>	<p>Choose One _____</p> <p><input checked="" type="radio"/> YES</p> <p><input type="radio"/> NO</p> <p>$y =$ <input type="text" value="2.0"/> ft</p> <p>$Vol_{12} =$ <input type="text" value="882"/> cu ft</p> <p>$D_o =$ <input type="text" value="11/16"/> in</p>

Design Procedure Form: Sand Filter (SF)

Sheet 2 of 2

Designer: D. Gorman
Company: M.V.E., Inc.
Date: September 13, 2019
Project: Sanctuary of Peace
Location: Sub-basin A1 - Sand Filter

5. Impermeable Geomembrane Liner and Geotextile Separator Fabric

A) Is an impermeable liner provided due to proximity of structures or groundwater contamination?

Choose One _____
 YES NO

6. Inlet / Outlet Works

A) Describe the type of energy dissipation at inlet points and means of conveying flows in excess of the WQCV through the outlet

emergency spillway with rip-rap protection
rip-rap at inflow points

Notes: _____

DETENTION BASIN STAGE-STORAGE TABLE BUILDER

UD-Detention, Version 3.07 (February 2017)

Project: **Sanctuary of Peace**

Basin ID: **Sub-basin A1 - Sand Filter - DP2**

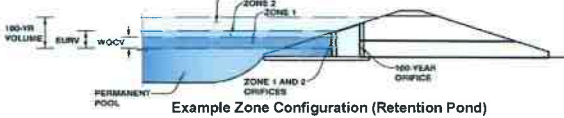

Example Zone Configuration (Retention Pond)

Required Volume Calculation

Selected BMP Type =	SF	
Watershed Area =	1.85	acres
Watershed Length =	317	ft
Watershed Slope =	0.073	ft/ft
Watershed Imperviousness =	35.70%	percent
Percentage Hydrologic Soil Group A =	0.0%	percent
Percentage Hydrologic Soil Group B =	100.0%	percent
Percentage Hydrologic Soil Groups C/D =	0.0%	percent
Desired WQCV Drain Time =	12.0	hours
Location for 1-hr Rainfall =	User Input	
Water Quality Capture Volume (WQCV) =	0.021	acre-feet
Excess Urban Runoff Volume (EURV) =	0.069	acre-feet
2-yr Runoff Volume (P1 = 1.19 in.) =	0.054	acre-feet
5-yr Runoff Volume (P1 = 1.5 in.) =	0.075	acre-feet
10-yr Runoff Volume (P1 = 1.75 in.) =	0.110	acre-feet
25-yr Runoff Volume (P1 = 2 in.) =	0.172	acre-feet
50-yr Runoff Volume (P1 = 2.25 in.) =	0.213	acre-feet
100-yr Runoff Volume (P1 = 2.52 in.) =	0.268	acre-feet
500-yr Runoff Volume (P1 = 3.4 in.) =	0.408	acre-feet
Approximate 2-yr Detention Volume =	0.050	acre-feet
Approximate 5-yr Detention Volume =	0.071	acre-feet
Approximate 10-yr Detention Volume =	0.099	acre-feet
Approximate 25-yr Detention Volume =	0.113	acre-feet
Approximate 50-yr Detention Volume =	0.118	acre-feet
Approximate 100-yr Detention Volume =	0.137	acre-feet

Optional User Override
1-hr Precipitation

1.19	inches
1.50	inches
1.75	inches
2.00	inches
2.25	inches
2.52	inches
3.40	inches

Stage-Storage Calculation

Zone 1 Volume (WQCV) =	0.021	acre-feet
Zone 2 Volume (EURV - Zone 1) =	0.048	acre-feet
Zone 3 Volume (100-year - Zones 1 & 2) =	0.069	acre-feet
Total Detention Basin Volume =	0.137	acre-feet
Initial Surcharge Volume (ISV) =	N/A	ft ³
Initial Surcharge Depth (ISD) =	N/A	ft
Total Available Detention Depth (H _{total}) =	3.00	ft
Depth of Trickle Channel (H _{trc}) =	N/A	ft
Slope of Trickle Channel (S _{trc}) =	N/A	ft/ft
Slopes of Main Basin Sides (S _{main}) =	3	H:V
Basin Length-to-Width Ratio (R _{L/W}) =	2	
Initial Surcharge Area (A _{ISV}) =	0	ft ²
Surcharge Volume Length (L _{ISV}) =	0.0	ft
Surcharge Volume Width (W _{ISV}) =	0.0	ft
Depth of Basin Floor (H _{FLOOR}) =	0.00	ft
Length of Basin Floor (L _{FLOOR}) =	49.4	ft
Width of Basin Floor (W _{FLOOR}) =	24.7	ft
Area of Basin Floor (A _{FLOOR}) =	1,222	ft ²
Volume of Basin Floor (V _{FLOOR}) =	0	ft ³
Depth of Main Basin (H _{MAIN}) =	3.00	ft
Length of Main Basin (L _{MAIN}) =	67.4	ft
Width of Main Basin (W _{MAIN}) =	42.7	ft
Area of Main Basin (A _{MAIN}) =	2,880	ft ²
Volume of Main Basin (V _{MAIN}) =	5,978	ft ³
Calculated Total Basin Volume (V _{total}) =	0.137	acre-feet

Stage - Storage Description	Stage (ft)	Optional Override Stage (ft)	Length (ft)	Width (ft)	Area (ft ²)	Optional Override Area (ft ²)	Area (acre)	Volume (ft ³)	Volume (ac-ft)
Media Surface	0.00		49.4	24.7	1,222		0.028		
	0.25		50.9	26.2	1,331		0.031	306	0.007
	0.50		52.4	27.7	1,448		0.033	653	0.015
Zone 1 (WQCV)	0.66		53.4	28.7	1,531		0.035	907	0.021
	0.75		53.9	29.2	1,571		0.036	1,031	0.024
	1.00		55.4	30.7	1,697		0.039	1,439	0.033
	1.25		56.9	32.2	1,829		0.042	1,880	0.043
	1.50		58.4	33.7	1,965		0.045	2,354	0.054
	1.75		59.9	35.2	2,105		0.048	2,863	0.066
Zone 2 (EURV)	1.81		60.3	35.6	2,145		0.049	3,011	0.069
	2.00		61.4	36.7	2,250		0.052	3,407	0.078
	2.25		62.9	38.2	2,405		0.055	4,012	0.092
	2.50		64.4	39.7	2,559		0.059	4,632	0.106
	2.75		65.9	41.2	2,717		0.062	5,292	0.121
Zone 3 (100-year)	3.00		67.4	42.7	2,880		0.066	5,991	0.138
	3.25		68.9	44.2	3,048		0.070	6,732	0.155
	3.50		70.4	45.7	3,220		0.074	7,516	0.173
	3.75		71.9	47.2	3,396		0.078	8,342	0.192
	4.00		73.4	48.7	3,577		0.082	9,214	0.212
	4.25		74.9	50.2	3,763		0.086	10,131	0.233
	4.50		76.4	51.7	3,953		0.091	11,096	0.255
	4.75		77.9	53.2	4,147		0.095	12,108	0.278
	5.00		79.4	54.7	4,346		0.100	13,170	0.302
	5.25		80.9	56.2	4,550		0.104	14,282	0.328
	5.50		82.4	57.7	4,758		0.109	15,445	0.355
	5.75		83.9	59.2	4,970		0.114	16,661	0.382
	6.00		85.4	60.7	5,187		0.119	17,930	0.412
	6.25		86.9	62.2	5,409		0.124	19,255	0.442
	6.50		88.4	63.7	5,634		0.129	20,635	0.474
	6.75		89.9	65.2	5,865		0.135	22,072	0.507
	7.00		91.4	66.7	6,100		0.140	23,568	0.541
	7.25		92.9	68.2	6,339		0.146	25,123	0.577
	7.50		94.4	69.7	6,583		0.151	26,738	0.614
	7.75		95.9	71.2	6,832		0.157	28,415	0.652
	8.00		97.4	72.7	7,085		0.163	30,154	0.692
	8.25		98.9	74.2	7,342		0.169	31,958	0.734
	8.50		100.4	75.7	7,604		0.175	33,826	0.777
	8.75		101.9	77.2	7,871		0.181	35,760	0.821
	9.00		103.4	78.7	8,142		0.187	37,761	0.867
	9.25		104.9	80.2	8,417		0.193	39,831	0.914
	9.50		106.4	81.7	8,697		0.200	41,970	0.964
	9.75		107.9	83.2	8,982		0.206	44,180	1.014
	10.00		109.4	84.7	9,271		0.213	46,462	1.067
	10.25		110.9	86.2	9,564		0.220	48,816	1.121
	10.50		112.4	87.7	9,862		0.226	51,244	1.176
	10.75		113.9	89.2	10,164		0.233	53,747	1.234
	11.00		115.4	90.7	10,471		0.240	56,327	1.293
	11.25		116.9	92.2	10,783		0.248	58,983	1.354
	11.50		118.4	93.7	11,099		0.255	61,719	1.417
	11.75		119.9	95.2	11,419		0.262	64,533	1.481
	12.00		121.4	96.7	11,744		0.270	67,429	1.548
	12.25		122.9	98.2	12,074		0.277	70,406	1.616
	12.50		124.4	99.7	12,408		0.285	73,466	1.687
	12.75		125.9	101.2	12,746		0.293	76,610	1.759

Detention Basin Outlet Structure Design

UD-Detention, Version 3.07 (February 2017)

Project: Sanctuary of Peace
 Basin ID: Sub-basin A1 - Sand Filter DP2

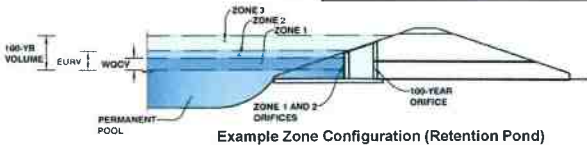

	Stage (ft)	Zone Volume (ac-ft)	Outlet Type
Zone 1 (WQCV)	0.66	0.021	Filtration Media
Zone 2 (EURV)	1.81	0.048	Orifice Plate
Zone 3 (100-year)	3.00	0.069	Weir&Pipe (Restrict)
		0.137	Total

User Input: Orifice at Underdrain Outlet (typically used to drain WQCV in a Filtration BMP)

Underdrain Orifice Invert Depth =	2.00	ft (distance below the filtration media surface)
Underdrain Orifice Diameter =	0.72	inches

Calculated Parameters for Underdrain

Underdrain Orifice Area =	0.0	ft ²
Underdrain Orifice Centroid =	0.03	feet

User Input: Orifice Plate with one or more orifices or Elliptical Slot Weir (typically used to drain WQCV and/or EURV in a sedimentation BMP)

Invert of Lowest Orifice =	0.66	ft (relative to basin bottom at Stage = 0 ft)
Depth at top of Zone using Orifice Plate =	1.86	ft (relative to basin bottom at Stage = 0 ft)
Orifice Plate: Orifice Vertical Spacing =	N/A	inches
Orifice Plate: Orifice Area per Row =	N/A	inches

Calculated Parameters for Plate

WQ Orifice Area per Row =	N/A	ft ²
Elliptical Half-Width =	N/A	feet
Elliptical Slot Centroid =	N/A	feet
Elliptical Slot Area =	N/A	ft ²

User Input: Stage and Total Area of Each Orifice Row (numbered from lowest to highest)

	Row 1 (required)	Row 2 (optional)	Row 3 (optional)	Row 4 (optional)	Row 5 (optional)	Row 6 (optional)	Row 7 (optional)	Row 8 (optional)
Stage of Orifice Centroid (ft)	0.65	1.06	1.46					
Orifice Area (sq. inches)	0.76	0.76	0.76					

	Row 9 (optional)	Row 10 (optional)	Row 11 (optional)	Row 12 (optional)	Row 13 (optional)	Row 14 (optional)	Row 15 (optional)	Row 16 (optional)
Stage of Orifice Centroid (ft)								
Orifice Area (sq. inches)								

User Input: Vertical Orifice (Circular or Rectangular)

	Not Selected	Not Selected	
Invert of Vertical Orifice =	N/A	N/A	ft (relative to basin bottom at Stage = 0 ft)
Depth at top of Zone using Vertical Orifice =	N/A	N/A	ft (relative to basin bottom at Stage = 0 ft)
Vertical Orifice Diameter =	N/A	N/A	inches

Calculated Parameters for Vertical Orifice

	Not Selected	Not Selected	
Vertical Orifice Area =	N/A	N/A	ft ²
Vertical Orifice Centroid =	N/A	N/A	feet

User Input: Overflow Weir (Dropbox) and Grate (Flat or Sloped)

	Zone 3 Weir	Not Selected	
Overflow Weir Front Edge Height, Ho =	2.00	N/A	ft (relative to basin bottom at Stage = 0 ft)
Overflow Weir Front Edge Length =	2.92	N/A	feet
Overflow Weir Slope =	0.00	N/A	H:V (enter zero for flat grate)
Horiz. Length of Weir Sides =	2.92	N/A	feet
Overflow Grate Open Area % =	81%	N/A	%, grate open area/total area
Debris Clogging % =	50%	N/A	%

Calculated Parameters for Overflow Weir

	Zone 3 Weir	Not Selected	
Height of Grate Upper Edge, H _g =	2.00	N/A	feet
Over Flow Weir Slope Length =	2.92	N/A	feet
Grate Open Area / 100-yr Orifice Area =	32.34	N/A	should be ≥ 4
Overflow Grate Open Area w/o Debris =	6.91	N/A	ft ²
Overflow Grate Open Area w/ Debris =	3.45	N/A	ft ²

User Input: Outlet Pipe w/ Flow Restriction Plate (Circular Orifice, Restrictor Plate, or Rectangular Orifice)

	Zone 3 Restrictor	Not Selected	
Depth to Invert of Outlet Pipe =	2.00	N/A	ft (distance below basin bottom at Stage = 0 ft)
Outlet Pipe Diameter =	12.00	N/A	inches
Restrictor Plate Height Above Pipe Invert =	3.80		inches

Calculated Parameters for Outlet Pipe w/ Flow Restriction Plate

	Zone 3 Restrictor	Not Selected	
Outlet Orifice Area =	0.21	N/A	ft ²
Outlet Orifice Centroid =	0.19	N/A	feet
Half-Central Angle of Restrictor Plate on Pipe =	1.20	N/A	radians

User Input: Emergency Spillway (Rectangular or Trapezoidal)

Spillway Invert Stage =	3.00	ft (relative to basin bottom at Stage = 0 ft)
Spillway Crest Length =	20.00	feet
Spillway End Slopes =	2.00	H:V
Freeboard above Max Water Surface =	1.00	feet

Calculated Parameters for Spillway

Spillway Design Flow Depth =	0.21	feet
Stage at Top of Freeboard =	4.21	feet
Basin Area at Top of Freeboard =	0.09	acres

Routed Hydrograph Results

	WQCV	EURV	2 Year	5 Year	10 Year	25 Year	50 Year	100 Year	500 Year
Design Storm Return Period =									
One-Hour Rainfall Depth (in)	0.53	1.07	1.19	1.50	1.75	2.00	2.25	2.52	3.40
Calculated Runoff Volume (acre-ft)	0.021	0.069	0.054	0.075	0.110	0.172	0.213	0.268	0.408
OPTIONAL Override Runoff Volume (acre-ft) =									
Inflow Hydrograph Volume (acre-ft)	0.020	0.068	0.053	0.075	0.109	0.172	0.213	0.267	0.407
Predevelopment Unit Peak Flow, q (cfs/acre)	0.00	0.00	0.02	0.03	0.29	0.90	1.24	1.64	2.61
Predevelopment Peak Q (cfs)	0.0	0.0	0.0	0.1	0.5	1.7	2.3	3.0	4.8
Peak Inflow Q (cfs)	0.5	1.6	1.3	1.8	2.6	4.0	4.9	6.2	9.4
Peak Outflow Q (cfs)	0.0	0.1	0.1	0.1	0.9	2.1	2.2	3.1	8.1
Ratio Peak Outflow to Predevelopment Q	N/A	N/A	N/A	1.7	1.7	1.3	0.9	1.0	1.7
Structure Controlling Flow	Filtration Media	Plate	Plate	Plate	Overflow Grate 1	Outlet Plate 1	Outlet Plate 1	Spillway	Spillway
Max Velocity through Grate 1 (fps)	N/A	N/A	N/A	N/A	0.1	0.3	0.3	0.3	0.3
Max Velocity through Grate 2 (fps)	N/A	N/A	N/A	N/A	N/A	N/A	N/A	N/A	N/A
Time to Drain 97% of Inflow Volume (hours)	12	23	21	24	25	24	23	22	20
Time to Drain 99% of Inflow Volume (hours)	12	24	22	25	26	26	26	25	25
Maximum Ponding Depth (ft)	0.58	1.64	1.35	1.77	2.09	2.27	2.60	3.06	3.21
Area at Maximum Ponding Depth (acres)	0.03	0.05	0.04	0.05	0.05	0.06	0.06	0.07	0.07
Maximum Volume Stored (acre-ft)	0.018	0.061	0.047	0.067	0.083	0.093	0.112	0.141	0.151

Detention Basin Outlet Structure Design

UD-Detention, Version 3.07 (February 2017)

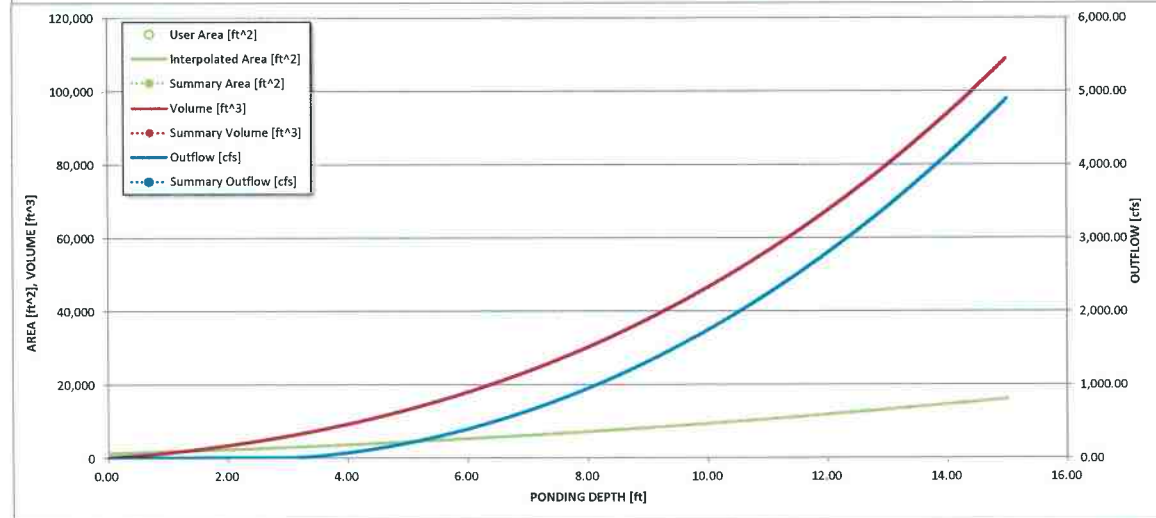
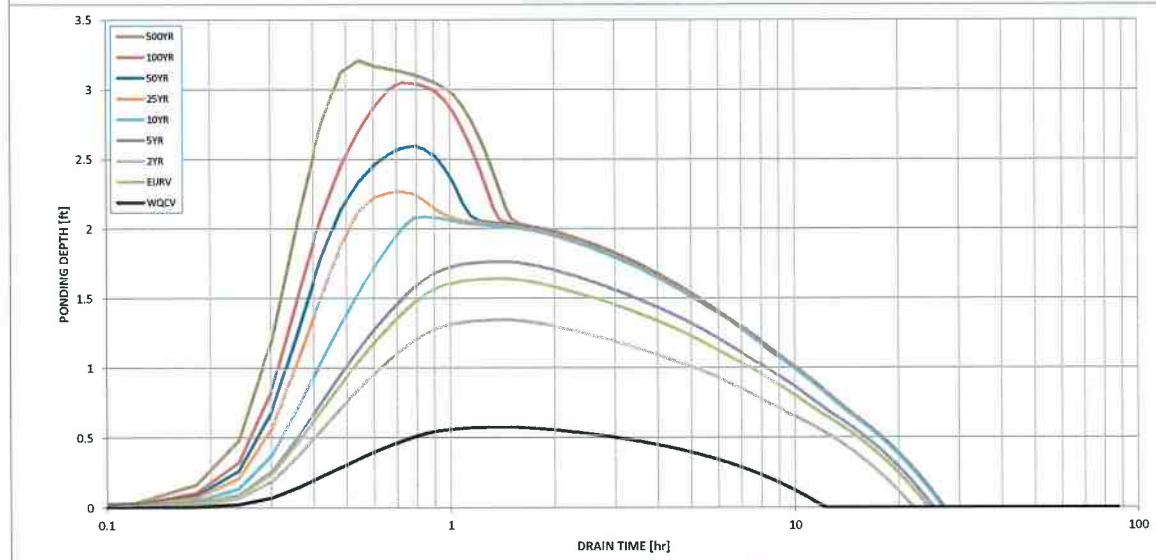
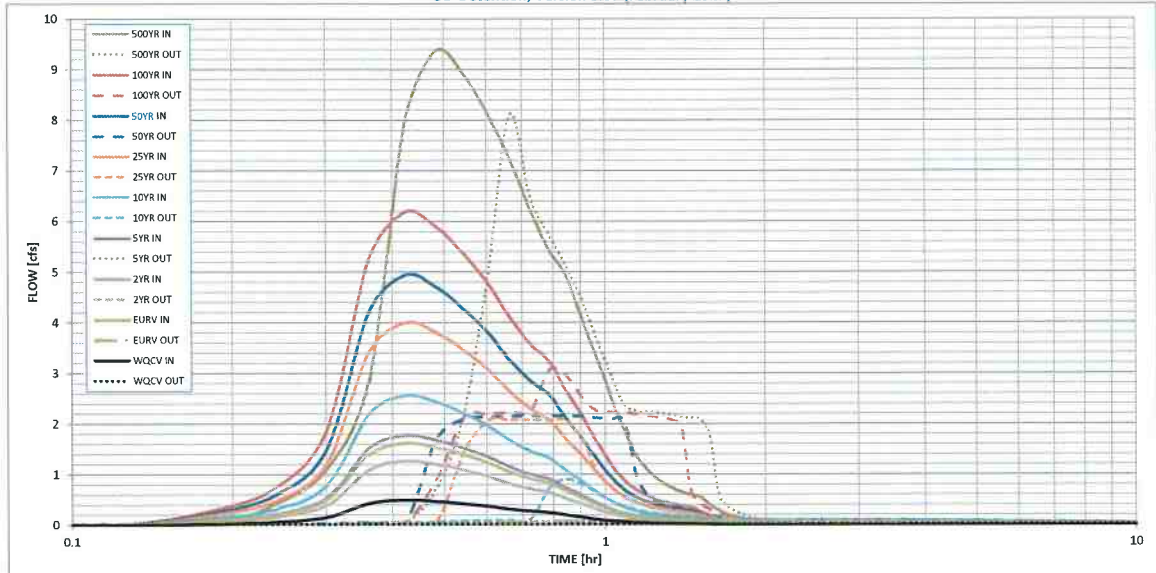

S-A-V-D Chart Axis Override

	X-axis	Left Y-Axis	Right Y-Axis
minimum bound			
maximum bound			

Design Procedure Form: Sand Filter (SF)

UD-BMP (Version 3.07, March 2018)

Sheet 1 of 2

Designer: D. Gorman
Company: M.V.E., Inc.
Date: September 13, 2019
Project: Sanctuary of Peace
Location: Sub-basin C1 - Sand Filter

<p>1. Basin Storage Volume</p> <p>A) Effective Imperviousness of Tributary Area, I_a (100% if all paved and roofed areas upstream of sand filter)</p> <p>B) Tributary Area's Imperviousness Ratio ($i = I_a/100$)</p> <p>C) Water Quality Capture Volume (WQCV) Based on 12-hour Drain Time $WQCV = 0.8 * (0.91 * i^3 - 1.19 * i^2 + 0.78 * i)$</p> <p>D) Contributing Watershed Area (including sand filter area)</p> <p>E) Water Quality Capture Volume (WQCV) Design Volume $V_{WQCV} = WQCV / 12 * Area$</p> <p>F) For Watersheds Outside of the Denver Region, Depth of Average Runoff Producing Storm</p> <p>G) For Watersheds Outside of the Denver Region, Water Quality Capture Volume (WQCV) Design Volume</p> <p>H) User Input of Water Quality Capture Volume (WQCV) Design Volume (Only if a different WQCV Design Volume is desired)</p>	<p>$I_a =$ <input type="text" value="25.0"/> %</p> <p>$i =$ <input type="text" value="0.250"/></p> <p>WQCV = <input type="text" value="0.11"/> watershed inches</p> <p>Area = <input type="text" value="177,412"/> sq ft</p> <p>$V_{WQCV} =$ <input type="text" value=""/> cu ft</p> <p>$d_6 =$ <input type="text" value="0.42"/> in</p> <p>$V_{WQCV\ OTHER} =$ <input type="text" value="1,558"/> cu ft</p> <p>$V_{WQCV\ USER} =$ <input type="text" value=""/> cu ft</p>
<p>2. Basin Geometry</p> <p>A) WQCV Depth</p> <p>B) Sand Filter Side Slopes (Horizontal distance per unit vertical, 4:1 or flatter preferred). Use "0" if sand filter has vertical walls.</p> <p>C) Minimum Filter Area (Flat Surface Area)</p> <p>D) Actual Filter Area</p> <p>E) Volume Provided</p>	<p>$D_{WQCV} =$ <input type="text" value="0.8"/> ft</p> <p>$Z =$ <input type="text" value="3.00"/> ft / ft DIFFICULT TO MAINTAIN, INCREASE WHERE POSSIBLE</p> <p>$A_{Min} =$ <input type="text" value="554"/> sq ft</p> <p>$A_{Actual} =$ <input type="text" value="1843"/> sq ft</p> <p>$V_T =$ <input type="text" value="1601"/> cu ft</p>
<p>3. Filter Material</p>	<p>Choose One _____</p> <p><input checked="" type="radio"/> 18" CDOT Class B or C Filter Material</p> <p><input type="radio"/> Other (Explain): _____</p> <p>_____</p> <p>_____</p>
<p>4. Underdrain System</p> <p>A) Are underdrains provided?</p> <p>B) Underdrain system orifice diameter for 12 hour drain time</p> <p style="margin-left: 20px;">i) Distance From Lowest Elevation of the Storage Volume to the Center of the Orifice</p> <p style="margin-left: 20px;">ii) Volume to Drain in 12 Hours</p> <p style="margin-left: 20px;">iii) Orifice Diameter, 3/8" Minimum</p>	<p>Choose One _____</p> <p><input checked="" type="radio"/> YES</p> <p><input type="radio"/> NO</p> <p>$y =$ <input type="text" value="2.0"/> ft</p> <p>$Vol_{12} =$ <input type="text" value="1,558"/> cu ft</p> <p>$D_o =$ <input type="text" value="15/16"/> in</p>

Design Procedure Form: Sand Filter (SF)

Sheet 2 of 2

Designer: D. Gorman
Company: M.V.E., Inc.
Date: September 13, 2019
Project: Sanctuary of Peace
Location: Sub-basin C1 - Sand Filter

5. Impermeable Geomembrane Liner and Geotextile Separator Fabric

A) Is an impermeable liner provided due to proximity of structures or groundwater contamination?

Choose One _____
 YES NO

6. Inlet / Outlet Works

A) Describe the type of energy dissipation at inlet points and means of conveying flows in excess of the WQCV through the outlet

emergency spillway with rip-rap protection
rip-rap at inflow points

Notes: _____

DETENTION BASIN STAGE-STORAGE TABLE BUILDER

UD-Detention, Version 3.07 (February 2017)

Project: Sanctuary of Peace

Basin ID: Sub-basin C1 - Sand Filter - DP6

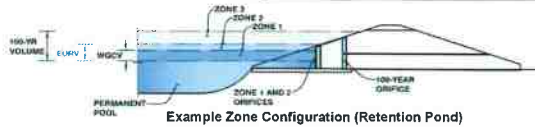

Example Zone Configuration (Retention Pond)

Required Volume Calculation

Selected BMP Type =	SF	
Watershed Area =	4.07	acres
Watershed Length =	557	ft
Watershed Slope =	0.066	ft/ft
Watershed Imperviousness =	25.00%	percent
Percentage Hydrologic Soil Group A =	0.0%	percent
Percentage Hydrologic Soil Group B =	100.0%	percent
Percentage Hydrologic Soil Groups C/D =	0.0%	percent
Desired WQCV Drain Time =	12.0	hours
Location for 1-hr Rainfall Depths =	User Input	
Water Quality Capture Volume (WQCV) =	0.037	acre-feet
Excess Urban Runoff Volume (EURV) =	0.103	acre-feet
2-yr Runoff Volume (P1 = 1.19 in.) =	0.077	acre-feet
5-yr Runoff Volume (P1 = 1.5 in.) =	0.112	acre-feet
10-yr Runoff Volume (P1 = 1.75 in.) =	0.180	acre-feet
25-yr Runoff Volume (P1 = 2 in.) =	0.324	acre-feet
50-yr Runoff Volume (P1 = 2.25 in.) =	0.417	acre-feet
100-yr Runoff Volume (P1 = 2.52 in.) =	0.538	acre-feet
500-yr Runoff Volume (P1 = 3.4 in.) =	0.844	acre-feet
Approximate 2-yr Detention Volume =	0.072	acre-feet
Approximate 5-yr Detention Volume =	0.105	acre-feet
Approximate 10-yr Detention Volume =	0.160	acre-feet
Approximate 25-yr Detention Volume =	0.191	acre-feet
Approximate 50-yr Detention Volume =	0.201	acre-feet
Approximate 100-yr Detention Volume =	0.242	acre-feet

Optional User Override 1-hr Precipitation	
1.19	inches
1.50	inches
1.75	inches
2.00	inches
2.25	inches
2.52	inches
3.40	inches

Stage-Storage Calculation

Zone 1 Volume (WQCV) =	0.037	acre-feet
Zone 2 Volume (EURV - Zone 1) =	0.066	acre-feet
Zone 3 Volume (100-year - Zones 1 & 2) =	0.139	acre-feet
Total Detention Basin Volume =	0.242	acre-feet
Initial Surcharge Volume (ISV) =	N/A	ft^3
Initial Surcharge Depth (ISD) =	N/A	ft
Total Available Detention Depth (H _{total}) =	3.50	ft
Depth of Trickle Channel (H _{TC}) =	N/A	ft
Slope of Trickle Channel (S _{TC}) =	N/A	ft/ft
Slopes of Main Basin Sides (S _{main}) =	3	H:V
Basin Length-to-Width Ratio (R _{L/W}) =	3	
Initial Surcharge Area (A _{ISV}) =	0	ft^2
Surcharge Volume Length (L _{ISV}) =	0.0	ft
Surcharge Volume Width (W _{ISV}) =	0.0	ft
Depth of Basin Floor (H _{fLOOR}) =	0.00	ft
Length of Basin Floor (L _{fLOOR}) =	74.3	ft
Width of Basin Floor (W _{fLOOR}) =	24.8	ft
Area of Basin Floor (A _{fLOOR}) =	1,843	ft^2
Volume of Basin Floor (V _{fLOOR}) =	0	ft^3
Depth of Main Basin (H _{MAIN}) =	3.50	ft
Length of Main Basin (L _{MAIN}) =	95.3	ft
Width of Main Basin (W _{MAIN}) =	45.8	ft
Area of Main Basin (A _{MAIN}) =	4,365	ft^2
Volume of Main Basin (V _{MAIN}) =	10,552	ft^3
Calculated Total Basin Volume (V _{total}) =	0.242	acre-feet

Stage - Storage Description	Stage (ft)	Optional Override Stage (ft)	Length (ft)	Width (ft)	Area (ft^2)	Optional Override Area (ft^2)	Area (acre)	Volume (ft^3)	Volume (ac-ft)
Media Surface	0.00		74.3	24.8	1,843		0.042		
	0.25		75.8	26.2	1,987		0.046	460	0.011
	0.50		77.3	27.7	2,143		0.049	976	0.022
	0.75		78.8	29.2	2,302		0.053	1,531	0.035
Zone 1 (WQCV)	0.77		79.0	29.4	2,322		0.053	1,601	0.037
	1.00		80.3	30.7	2,467		0.057	2,127	0.049
	1.25		81.8	32.2	2,636		0.061	2,765	0.063
	1.50		83.3	33.7	2,809		0.064	3,445	0.079
	1.75		84.8	35.2	2,987		0.069	4,170	0.096
Zone 2 (EURV)	1.85		85.4	35.9	3,066		0.070	4,503	0.103
	2.00		86.3	36.7	3,169		0.073	4,939	0.113
	2.25		87.8	38.3	3,363		0.077	5,788	0.133
	2.50		89.3	39.8	3,555		0.082	6,653	0.153
	2.75		90.8	41.3	3,751		0.086	7,566	0.174
	3.00		92.3	42.8	3,951		0.091	8,528	0.196
	3.25		93.8	44.3	4,156		0.095	9,542	0.219
Zone 3 (100-year)	3.49		95.3	45.7	4,357		0.100	10,563	0.242
	3.50		95.3	45.8	4,365		0.100	10,607	0.243
	3.75		96.8	47.3	4,579		0.105	11,725	0.269
	4.00		98.3	48.8	4,798		0.110	12,897	0.296
	4.25		99.8	50.3	5,021		0.115	14,124	0.324
	4.50		101.3	51.8	5,248		0.120	15,408	0.354
	4.75		102.8	53.3	5,480		0.126	16,749	0.384
	5.00		104.3	54.8	5,717		0.131	18,148	0.417
	5.25		105.8	56.3	5,958		0.137	19,607	0.450
	5.50		107.3	57.8	6,203		0.142	21,127	0.485
	5.75		108.8	59.3	6,453		0.148	22,709	0.521
	6.00		110.3	60.8	6,707		0.154	24,354	0.559
	6.25		111.8	62.3	6,966		0.160	26,063	0.598
	6.50		113.3	63.8	7,230		0.166	27,838	0.639
	6.75		114.8	65.3	7,498		0.172	29,678	0.681
	7.00		116.3	66.8	7,770		0.178	31,587	0.725
	7.25		117.8	68.3	8,047		0.185	33,564	0.771
	7.50		119.3	69.8	8,329		0.191	35,611	0.818
	7.75		120.8	71.3	8,615		0.198	37,729	0.866
	8.00		122.3	72.8	8,905		0.204	39,918	0.916
	8.25		123.8	74.3	9,200		0.211	42,181	0.968
	8.50		125.3	75.8	9,499		0.218	44,519	1.022
	8.75		126.8	77.3	9,803		0.225	46,932	1.077
	9.00		128.3	78.8	10,112		0.232	49,421	1.135
	9.25		129.8	80.3	10,425		0.239	51,988	1.193
	9.50		131.3	81.8	10,742		0.247	54,634	1.254
	9.75		132.8	83.3	11,064		0.254	57,359	1.317
	10.00		134.3	84.8	11,391		0.261	60,166	1.381
	10.25		135.8	86.3	11,722		0.269	63,055	1.448
	10.50		137.3	87.8	12,057		0.277	66,027	1.516
	10.75		138.8	89.3	12,397		0.285	69,084	1.586
	11.00		140.3	90.8	12,741		0.293	72,226	1.658
	11.25		141.8	92.3	13,090		0.301	75,455	1.732
	11.50		143.3	93.8	13,444		0.309	78,772	1.808
	11.75		144.8	95.3	13,802		0.317	82,177	1.887
	12.00		146.3	96.8	14,164		0.325	85,673	1.967
	12.25		147.8	98.3	14,531		0.334	89,260	2.049
	12.50		149.3	99.8	14,903		0.342	92,939	2.134

Detention Basin Outlet Structure Design

UD-Detention, Version 3.07 (February 2017)

Project: Sanctuary of Peace
Basin ID: Sub-basin C1 - Sand Filter DP6

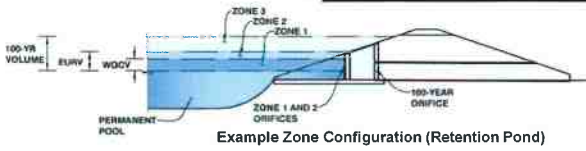

	Stage (ft)	Zone Volume (ac-ft)	Outlet Type
Zone 1 (WQCV)	0.77	0.037	Filtration Media
Zone 2 (EURV)	1.85	0.066	Orifice Plate
Zone 3 (100-year)	3.49	0.139	Weir&Pipe (Restrict)
		0.242	Total

User Input: Orifice at Underdrain Outlet (typically used to drain WQCV in a Filtration BMP)

Underdrain Orifice Invert Depth = 2.00 ft (distance below the filtration media surface)
Underdrain Orifice Diameter = 0.96 inches

Calculated Parameters for Underdrain

Underdrain Orifice Area = 0.0 ft²
Underdrain Orifice Centroid = 0.04 feet

User Input: Orifice Plate with one or more orifices or Elliptical Slot Weir (typically used to drain WQCV and/or EURV in a sedimentation BMP)

Invert of Lowest Orifice = 0.77 ft (relative to basin bottom at Stage = 0 ft)
Depth at top of Zone using Orifice Plate = 1.86 ft (relative to basin bottom at Stage = 0 ft)
Orifice Plate: Orifice Vertical Spacing = 4.20 inches
Orifice Plate: Orifice Area per Row = 0.68 sq. inches (diameter = 15/16 inch)

Calculated Parameters for Plate

WQ Orifice Area per Row = 4.722E-03 ft²
Elliptical Half-Width = N/A feet
Elliptical Slot Centroid = N/A feet
Elliptical Slot Area = N/A ft²

User Input: Stage and Total Area of Each Orifice Row (numbered from lowest to highest)

	Row 1 (required)	Row 2 (optional)	Row 3 (optional)	Row 4 (optional)	Row 5 (optional)	Row 6 (optional)	Row 7 (optional)	Row 8 (optional)
Stage of Orifice Centroid (ft)	0.77	1.13	1.50					
Orifice Area (sq. inches)	0.68	0.68	0.68					

	Row 9 (optional)	Row 10 (optional)	Row 11 (optional)	Row 12 (optional)	Row 13 (optional)	Row 14 (optional)	Row 15 (optional)	Row 16 (optional)
Stage of Orifice Centroid (ft)								
Orifice Area (sq. inches)								

User Input: Vertical Orifice (Circular or Rectangular)

	Not Selected	Not Selected	
Invert of Vertical Orifice =	N/A	N/A	ft (relative to basin bottom at Stage = 0 ft)
Depth at top of Zone using Vertical Orifice =	N/A	N/A	ft (relative to basin bottom at Stage = 0 ft)
Vertical Orifice Diameter =	N/A	N/A	inches

Calculated Parameters for Vertical Orifice

	Not Selected	Not Selected	
Vertical Orifice Area =	N/A	N/A	ft ²
Vertical Orifice Centroid =	N/A	N/A	feet

User Input: Overflow Weir (Dropbox) and Grate (Flat or Sloped)

	Zone 3 Weir	Not Selected	
Overflow Weir Front Edge Height, H _o =	2.00	N/A	ft (relative to basin bottom at Stage = 0 ft)
Overflow Weir Front Edge Length =	2.92	N/A	feet
Overflow Weir Slope =	0.00	N/A	H:V (enter zero for flat grate)
Horiz. Length of Weir Sides =	2.92	N/A	feet
Overflow Grate Open Area % =	81%	N/A	% grate open area/total area
Debris Clogging % =	50%	N/A	%

Calculated Parameters for Overflow Weir

	Zone 3 Weir	Not Selected	
Height of Grate Upper Edge, H _i =	2.00	N/A	feet
Over Flow Weir Slope Length =	2.92	N/A	feet
Grate Open Area / 100-yr Orifice Area =	18.37	N/A	should be ≥ 4
Overflow Grate Open Area w/o Debris =	6.91	N/A	ft ²
Overflow Grate Open Area w/ Debris =	3.45	N/A	ft ²

User Input: Outlet Pipe w/ Flow Restriction Plate (Circular Orifice, Restrictor Plate, or Rectangular Orifice)

	Zone 3 Restrictor	Not Selected	
Depth to Invert of Outlet Pipe =	2.00	N/A	ft (distance below basin bottom at Stage = 0 ft)
Outlet Pipe Diameter =	12.00	N/A	inches
Restrictor Plate Height Above Pipe Invert =	5.80		inches

Calculated Parameters for Outlet Pipe w/ Flow Restriction Plate

	Zone 3 Restrictor	Not Selected	
Outlet Orifice Area =	0.38	N/A	ft ²
Outlet Orifice Centroid =	0.28	N/A	feet
Half-Central Angle of Restrictor Plate on Pipe =	1.54	N/A	radians

User Input: Emergency Spillway (Rectangular or Trapezoidal)

Spillway Invert Stage = 3.50 ft (relative to basin bottom at Stage = 0 ft)
Spillway Crest Length = 24.00 feet
Spillway End Slopes = 2.00 H:V
Freeboard above Max Water Surface = 1.00 feet

Calculated Parameters for Spillway

Spillway Design Flow Depth = 0.27 feet
Stage at Top of Freeboard = 4.77 feet
Basin Area at Top of Freeboard = 0.13 acres

Routed Hydrograph Results

	WQCV	EURV	2 Year	5 Year	10 Year	25 Year	50 Year	100 Year	500 Year
Design Storm Return Period =									
One-Hour Rainfall Depth (in)	0.53	1.07	1.19	1.50	1.75	2.00	2.25	2.52	3.40
Calculated Runoff Volume (acre-ft)	0.037	0.103	0.077	0.112	0.180	0.324	0.417	0.538	0.844
OPTIONAL Override Runoff Volume (acre-ft)									
Inflow Hydrograph Volume (acre-ft)	0.036	0.102	0.077	0.112	0.179	0.323	0.416	0.537	0.843
Predevelopment Unit Peak Flow, q (cfs/acre)	0.00	0.00	0.01	0.02	0.25	0.79	1.09	1.46	2.32
Predevelopment Peak Q (cfs)	0.0	0.0	0.1	0.1	1.0	3.2	4.4	5.9	9.5
Peak Inflow Q (cfs)	0.8	2.1	1.6	2.3	3.7	6.6	8.4	10.8	16.9
Peak Outflow Q (cfs)	0.0	0.1	0.1	0.1	1.7	3.7	3.9	6.1	13.9
Ratio Peak Outflow to Predevelopment Q	N/A	N/A	N/A	1.0	1.7	1.2	0.9	1.0	1.5
Structure Controlling Flow =	Filtration Media	Plate	Plate	Plate	Overflow Grate 1	Outlet Plate 1	Outlet Plate 1	Spillway	Spillway
Max Velocity through Grate 1 (fps)	N/A	N/A	N/A	N/A	0.2	0.5	0.5	0.6	0.6
Max Velocity through Grate 2 (fps)	N/A	N/A	N/A	N/A	N/A	N/A	N/A	N/A	N/A
Time to Drain 97% of Inflow Volume (hours)	12	23	20	24	25	24	23	22	19
Time to Drain 99% of Inflow Volume (hours)	12	24	21	25	27	26	26	26	25
Maximum Ponding Depth (ft)	0.67	1.69	1.33	1.81	2.14	2.46	3.00	3.59	3.76
Area at Maximum Ponding Depth (acres)	0.05	0.07	0.06	0.07	0.08	0.08	0.09	0.10	0.11
Maximum Volume Stored (acre-ft)	0.031	0.092	0.068	0.101	0.124	0.149	0.196	0.252	0.269

Detention Basin Outlet Structure Design

UD-Detention, Version 3.07 (February 2017)

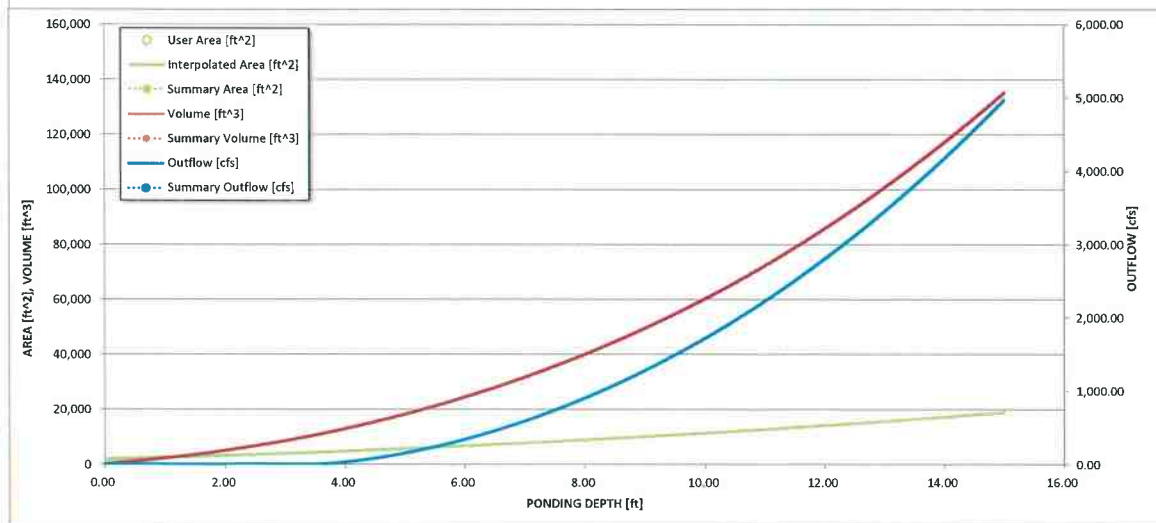
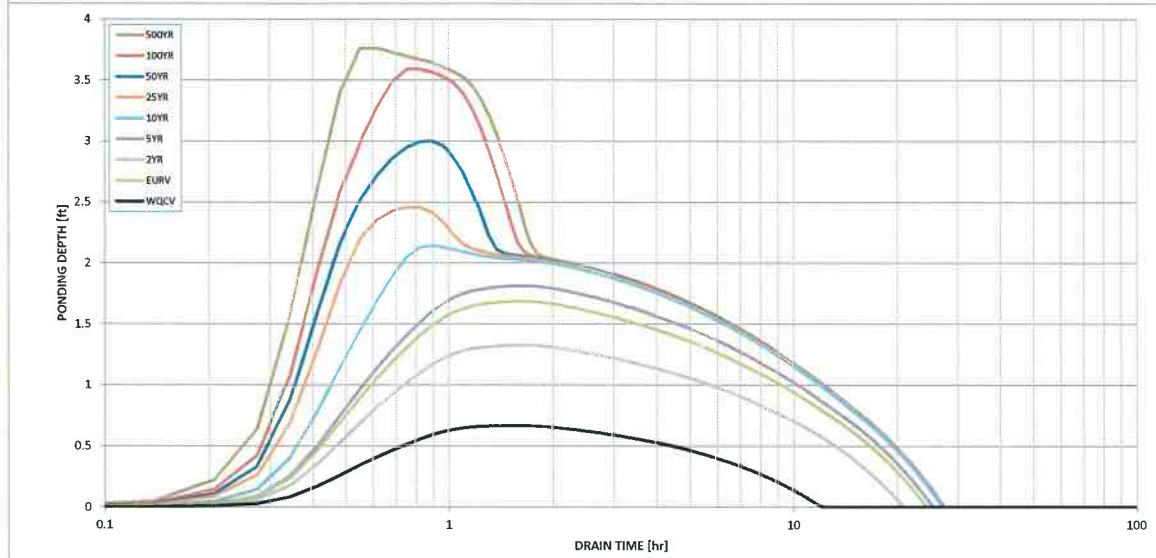
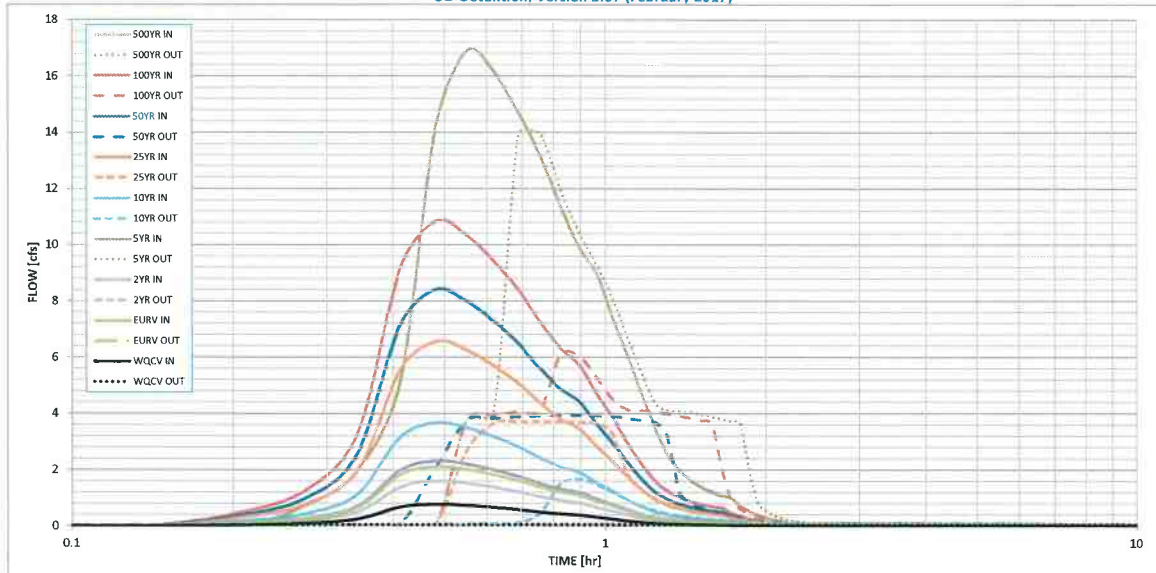

S-A-V-D Chart Axis Override

	X-axis	Left Y-Axis	Right Y-Axis
minimum bound			
maximum bound			

Design Procedure Form: Sand Filter (SF)

UD-BMP (Version 3.07, March 2018)

Sheet 1 of 2

Designer: D. Gorman
 Company: M.V.E., Inc.
 Date: September 13, 2019
 Project: Sanctuary of Peace
 Location: Sub-basin C2 - Sand Filter

<p>1. Basin Storage Volume</p> <p>A) Effective Imperviousness of Tributary Area, I_p (100% if all paved and roofed areas upstream of sand filter)</p> <p>B) Tributary Area's Imperviousness Ratio ($i = I_p/100$)</p> <p>C) Water Quality Capture Volume (WQCV) Based on 12-hour Drain Time $WQCV = 0.8 * (0.91 * i^3 - 1.19 * i^2 + 0.78 * i)$</p> <p>D) Contributing Watershed Area (including sand filter area)</p> <p>E) Water Quality Capture Volume (WQCV) Design Volume $V_{WQCV} = WQCV / 12 * Area$</p> <p>F) For Watersheds Outside of the Denver Region, Depth of Average Runoff Producing Storm</p> <p>G) For Watersheds Outside of the Denver Region, Water Quality Capture Volume (WQCV) Design Volume</p> <p>H) User Input of Water Quality Capture Volume (WQCV) Design Volume (Only if a different WQCV Design Volume is desired)</p>	<p>$I_p =$ <input type="text" value="26.7"/> %</p> <p>$i =$ <input type="text" value="0.267"/></p> <p>WQCV = <input type="text" value="0.11"/> watershed inches</p> <p>Area = <input type="text" value="28,884"/> sq ft</p> <p>$V_{WQCV} =$ <input type="text" value=""/> cu ft</p> <p>$d_s =$ <input type="text" value="0.42"/> in</p> <p>$V_{WQCV\ OTHER} =$ <input type="text" value="265"/> cu ft</p> <p>$V_{WQCV\ USER} =$ <input type="text" value=""/> cu ft</p>
<p>2. Basin Geometry</p> <p>A) WQCV Depth</p> <p>B) Sand Filter Side Slopes (Horizontal distance per unit vertical, 4:1 or flatter preferred). Use "0" if sand filter has vertical walls.</p> <p>C) Minimum Filter Area (Flat Surface Area)</p> <p>D) Actual Filter Area</p> <p>E) Volume Provided</p>	<p>$D_{WQCV} =$ <input type="text" value="0.9"/> ft</p> <p>$Z =$ <input type="text" value="3.00"/> ft / ft DIFFICULT TO MAINTAIN, INCREASE WHERE POSSIBLE</p> <p>$A_{Min} =$ <input type="text" value="96"/> sq ft</p> <p>$A_{Actual} =$ <input type="text" value="546"/> sq ft</p> <p>$V_T =$ <input type="text" value="270"/> cu ft</p>
<p>3. Filter Material</p>	<p>Choose One _____</p> <p><input checked="" type="radio"/> 18" CDOT Class B or C Filter Material</p> <p><input type="radio"/> Other (Explain): _____</p> <p>_____</p> <p>_____</p>
<p>4. Underdrain System</p> <p>A) Are underdrains provided?</p> <p>B) Underdrain system orifice diameter for 12 hour drain time</p> <p style="margin-left: 20px;">i) Distance From Lowest Elevation of the Storage Volume to the Center of the Orifice</p> <p style="margin-left: 20px;">ii) Volume to Drain in 12 Hours</p> <p style="margin-left: 20px;">iii) Orifice Diameter, 3/8" Minimum</p>	<p>Choose One _____</p> <p><input checked="" type="radio"/> YES</p> <p><input type="radio"/> NO</p> <p>$y =$ <input type="text" value="2.0"/> ft</p> <p>$Vol_{12} =$ <input type="text" value="265"/> cu ft</p> <p>$D_o =$ <input type="text" value="3/8"/> in</p>

Design Procedure Form: Sand Filter (SF)

Sheet 2 of 2

Designer: D. Gorman
Company: M.V.E., Inc.
Date: September 13, 2019
Project: Sanctuary of Peace
Location: Sub-basin C2 - Sand Filter

5. Impermeable Geomembrane Liner and Geotextile Separator Fabric

A) Is an impermeable liner provided due to proximity of structures or groundwater contamination?

Choose One _____
 YES NO

6. Inlet / Outlet Works

A) Describe the type of energy dissipation at inlet points and means of conveying flows in excess of the WQCV through the outlet

emergency spillway with rip-rap protection
rip-rap at inflow points

Notes: _____

DETENTION BASIN STAGE-STORAGE TABLE BUILDER

UD-Detention, Version 3.07 (February 2017)

Project: Sanctuary of Peace

Basin ID: Sub-basin C2 - Sand Filter - DP3

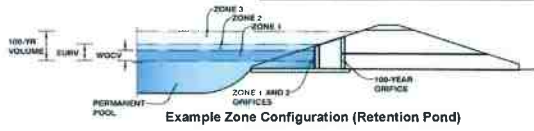

Required Volume Calculation

Selected BMP Type =	SF	
Watershed Area =	0.66	acres
Watershed Length =	189	ft
Watershed Slope =	0.063	ft/ft
Watershed Imperviousness =	26.70%	percent
Percentage Hydrologic Soil Group A =	0.0%	percent
Percentage Hydrologic Soil Group B =	100.0%	percent
Percentage Hydrologic Soil Groups C/D =	0.0%	percent
Desired WQCV Drain Time =	12.0	hours
Location for 1-hr Rainfall Depths =	User Input	
Water Quality Capture Volume (WQCV) =	0.006	acre-feet
Excess Urban Runoff Volume (EURV) =	0.018	acre-feet
2-yr Runoff Volume (P1 = 1.19 in.) =	0.014	acre-feet
5-yr Runoff Volume (P1 = 1.5 in.) =	0.020	acre-feet
10-yr Runoff Volume (P1 = 1.75 in.) =	0.031	acre-feet
25-yr Runoff Volume (P1 = 2 in.) =	0.054	acre-feet
50-yr Runoff Volume (P1 = 2.25 in.) =	0.069	acre-feet
100-yr Runoff Volume (P1 = 2.52 in.) =	0.089	acre-feet
500-yr Runoff Volume (P1 = 3.4 in.) =	0.138	acre-feet
Approximate 2-yr Detention Volume =	0.013	acre-feet
Approximate 5-yr Detention Volume =	0.018	acre-feet
Approximate 10-yr Detention Volume =	0.027	acre-feet
Approximate 25-yr Detention Volume =	0.032	acre-feet
Approximate 50-yr Detention Volume =	0.034	acre-feet
Approximate 100-yr Detention Volume =	0.041	acre-feet

Optional User Override 1-hr Precipitation	
1.19	inches
1.50	inches
1.75	inches
2.00	inches
2.25	inches
2.52	inches
3.40	inches

Stage-Storage Calculation

Zone 1 Volume (WQCV) =	0.006	acre-feet
Zone 2 Volume (EURV - Zone 1) =	0.012	acre-feet
Zone 3 Volume (100-year - Zones 1 & 2) =	0.023	acre-feet
Total Detention Basin Volume =	0.041	acre-feet
Initial Surcharge Volume (ISV) =	N/A	ft ³
Initial Surcharge Depth (ISD) =	N/A	ft
Total Available Detention Depth (H _{total}) =	2.00	ft
Depth of Trickle Channel (H _{TC}) =	N/A	ft
Slope of Trickle Channel (S _{TC}) =	N/A	ft/ft
Slopes of Main Basin Sides (S _{main}) =	3	H:V
Basin Length-to-Width Ratio (R _{L/W}) =	2	
Initial Surcharge Area (A _{ISV}) =	0	ft ²
Surcharge Volume Length (L _{ISV}) =	0.0	ft
Surcharge Volume Width (W _{ISV}) =	0.0	ft
Depth of Basin Floor (H _{FLOOR}) =	0.00	ft
Length of Basin Floor (L _{FLOOR}) =	33.0	ft
Width of Basin Floor (W _{FLOOR}) =	16.5	ft
Area of Basin Floor (A _{FLOOR}) =	546	ft ²
Volume of Basin Floor (V _{FLOOR}) =	0	ft ³
Depth of Main Basin (H _{MAIN}) =	2.00	ft
Length of Main Basin (L _{MAIN}) =	45.0	ft
Width of Main Basin (W _{MAIN}) =	28.5	ft
Area of Main Basin (A _{MAIN}) =	1,285	ft ²
Volume of Main Basin (V _{MAIN}) =	1,779	ft ³
Calculated Total Basin Volume (V _{total}) =	0.041	acre-feet

Depth Increment =	0.25	ft							
Stage - Storage Description	Stage (ft)	Optional Override Stage (ft)	Length (ft)	Width (ft)	Area (ft ²)	Optional Override Area (ft ²)	Area (acre)	Volume (ft ³)	Volume (ac-ft)
Media Surface	0.00		33.0	16.5	546		0.013		
	0.25		34.5	18.0	619		0.014	140	0.003
Zone 1 (WQCV)	0.44		35.7	19.2	684		0.016	270	0.006
	0.50		36.0	19.5	700		0.016	305	0.007
	0.75		37.5	21.0	786		0.018	490	0.011
	1.00		39.0	22.5	876		0.020	698	0.016
Zone 2 (EURV)	1.09		39.6	23.1	913		0.021	787	0.018
	1.25		40.5	24.0	970		0.022	929	0.021
	1.50		42.0	25.5	1,069		0.025	1,183	0.027
	1.75		43.5	27.0	1,173		0.027	1,464	0.034
	2.00		45.0	28.5	1,280		0.029	1,770	0.041
Zone 3 (100-year)	2.00		45.0	28.5	1,285		0.029	1,783	0.041
	2.25		46.5	30.0	1,397		0.032	2,118	0.049
	2.50		48.0	31.5	1,515		0.035	2,482	0.057
	2.75		49.5	33.0	1,636		0.038	2,876	0.066
	3.00		51.0	34.5	1,762		0.040	3,300	0.076
	3.25		52.5	36.0	1,893		0.043	3,757	0.086
	3.50		54.0	37.5	2,028		0.047	4,247	0.098
	3.75		55.5	39.0	2,168		0.050	4,772	0.110
	4.00		57.0	40.5	2,312		0.053	5,331	0.122
	4.25		58.5	42.0	2,460		0.056	5,928	0.136
	4.50		60.0	43.5	2,613		0.060	6,562	0.151
	4.75		61.5	45.0	2,771		0.064	7,235	0.166
	5.00		63.0	46.5	2,933		0.067	7,948	0.182
	5.25		64.5	48.0	3,100		0.071	8,702	0.200
	5.50		66.0	49.5	3,271		0.075	9,498	0.218
	5.75		67.5	51.0	3,446		0.079	10,338	0.237
	6.00		69.0	52.5	3,627		0.083	11,222	0.258
	6.25		70.5	54.0	3,811		0.087	12,151	0.279
	6.50		72.0	55.5	4,000		0.092	13,128	0.301
	6.75		73.5	57.0	4,194		0.096	14,152	0.325
	7.00		75.0	58.5	4,392		0.101	15,225	0.350
	7.25		76.5	60.0	4,595		0.105	16,348	0.375
	7.50		78.0	61.5	4,802		0.110	17,523	0.402
	7.75		79.5	63.0	5,013		0.115	18,749	0.430
	8.00		81.0	64.5	5,229		0.120	20,030	0.460
	8.25		82.5	66.0	5,450		0.125	21,364	0.490
	8.50		84.0	67.5	5,675		0.130	22,755	0.522
	8.75		85.5	69.0	5,905		0.136	24,202	0.556
	9.00		87.0	70.5	6,139		0.141	25,708	0.590
	9.25		88.5	72.0	6,377		0.146	27,272	0.626
	9.50		90.0	73.5	6,620		0.152	28,897	0.663
	9.75		91.5	75.0	6,868		0.158	30,583	0.702
	10.00		93.0	76.5	7,120		0.163	32,331	0.742
	10.25		94.5	78.0	7,377		0.169	34,143	0.784
	10.50		96.0	79.5	7,638		0.175	36,020	0.827
	10.75		97.5	81.0	7,904		0.181	37,962	0.871
	11.00		99.0	82.5	8,174		0.188	39,972	0.918
	11.25		100.5	84.0	8,448		0.194	42,050	0.965
	11.50		102.0	85.5	8,727		0.200	44,197	1.015
	11.75		103.5	87.0	9,011		0.207	46,414	1.066
	12.00		105.0	88.5	9,299		0.213	48,702	1.118
	12.25		106.5	90.0	9,592		0.220	51,064	1.172
	12.50		108.0	91.5	9,889		0.227	53,499	1.228

Detention Basin Outlet Structure Design

UD-Detention, Version 3.07 (February 2017)

Project: Sanctuary of Peace
Basin ID: Sub-basin C2 - Sand Filter DP3

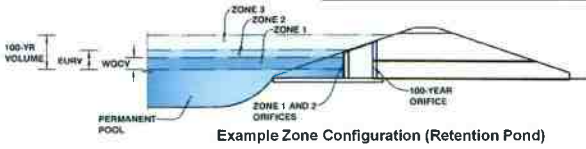

	Stage (ft)	Zone Volume (ac-ft)	Outlet Type
Zone 1 (WQCV)	0.44	0.006	Filtration Media
Zone 2 (EURV)	1.09	0.012	Orifice Plate
Zone 3 (100-year)	2.00	0.023	Weir&Pipe (Restrict)
		0.041	Total

User Input: Orifice at Underdrain Outlet (typically used to drain WQCV in a Filtration BMP)

Underdrain Orifice Invert Depth =	2.00	ft (distance below the filtration media surface)
Underdrain Orifice Diameter =	0.38	inches

Calculated Parameters for Underdrain

Underdrain Orifice Area =	0.0	ft ²
Underdrain Orifice Centroid =	0.02	feet

User Input: Orifice Plate with one or more orifices or Elliptical Slot Weir (typically used to drain WQCV and/or EURV in a sedimentation BMP)

Invert of Lowest Orifice =	0.44	ft (relative to basin bottom at Stage = 0 ft)
Depth at top of Zone using Orifice Plate =	1.09	ft (relative to basin bottom at Stage = 0 ft)
Orifice Plate: Orifice Vertical Spacing =	4.20	inches
Orifice Plate: Orifice Area per Row =	0.28	sq. inches (diameter = 9/16 inch)

Calculated Parameters for Plate

WQ Orifice Area per Row =	1.944E-03	ft ²
Elliptical Half-Width =	N/A	feet
Elliptical Slot Centroid =	N/A	feet
Elliptical Slot Area =	N/A	ft ²

User Input: Stage and Total Area of Each Orifice Row (numbered from lowest to highest)

	Row 1 (required)	Row 2 (optional)	Row 3 (optional)	Row 4 (optional)	Row 5 (optional)	Row 6 (optional)	Row 7 (optional)	Row 8 (optional)
Stage of Orifice Centroid (ft)	0.44	0.66	0.87					
Orifice Area (sq. inches)	0.28	0.28	0.28					

	Row 9 (optional)	Row 10 (optional)	Row 11 (optional)	Row 12 (optional)	Row 13 (optional)	Row 14 (optional)	Row 15 (optional)	Row 16 (optional)
Stage of Orifice Centroid (ft)								
Orifice Area (sq. inches)								

User Input: Vertical Orifice (Circular or Rectangular)

	Not Selected	Not Selected	
Invert of Vertical Orifice =	N/A	N/A	ft (relative to basin bottom at Stage = 0 ft)
Depth at top of Zone using Vertical Orifice =	N/A	N/A	ft (relative to basin bottom at Stage = 0 ft)
Vertical Orifice Diameter =	N/A	N/A	inches

Calculated Parameters for Vertical Orifice

	Not Selected	Not Selected	
Vertical Orifice Area =	N/A	N/A	ft ²
Vertical Orifice Centroid =	N/A	N/A	feet

User Input: Overflow Weir (Dropbox) and Grate (Flat or Sloped)

	Zone 3 Weir	Not Selected	
Overflow Weir Front Edge Height, H _o =	1.25	N/A	ft (relative to basin bottom at Stage = 0 ft)
Overflow Weir Front Edge Length =	2.92	N/A	feet
Overflow Weir Slope =	0.00	N/A	H:V (enter zero for flat grate)
Horiz. Length of Weir Sides =	2.92	N/A	feet
Overflow Grate Open Area % =	81%	N/A	% grate open area/total area
Debris Clogging % =	50%	N/A	%

Calculated Parameters for Overflow Weir

	Zone 3 Weir	Not Selected	
Height of Grate Upper Edge, H _g =	1.25	N/A	feet
Over Flow Weir Slope Length =	2.92	N/A	feet
Grate Open Area / 100-yr Orifice Area =	80.27	N/A	should be ≥ 4
Overflow Grate Open Area w/o Debris =	6.91	N/A	ft ²
Overflow Grate Open Area w/ Debris =	3.45	N/A	ft ²

User Input: Outlet Pipe w/ Flow Restriction Plate (Circular Orifice, Restrictor Plate, or Rectangular Orifice)

	Zone 3 Restrictor	Not Selected	
Depth to Invert of Outlet Pipe =	2.00	N/A	ft (distance below basin bottom at Stage = 0 ft)
Outlet Pipe Diameter =	12.00	N/A	inches
Restrictor Plate Height Above Pipe Invert =	2.00	N/A	inches

Calculated Parameters for Outlet Pipe w/ Flow Restriction Plate

	Zone 3 Restrictor	Not Selected	
Outlet Orifice Area =	0.09	N/A	ft ²
Outlet Orifice Centroid =	0.10	N/A	feet
Half-Central Angle of Restrictor Plate on Pipe =	0.84	N/A	radians

User Input: Emergency Spillway (Rectangular or Trapezoidal)

Spillway Invert Stage =	2.00	ft (relative to basin bottom at Stage = 0 ft)
Spillway Crest Length =	10.00	feet
Spillway End Slopes =	2.00	H:V
Freeboard above Max Water Surface =	1.00	feet

Calculated Parameters for Spillway

Spillway Design Flow Depth =	0.16	feet
Stage at Top of Freeboard =	3.16	feet
Basin Area at Top of Freeboard =	0.04	acres

Routed Hydrograph Results

	WQCV	EURV	2 Year	5 Year	10 Year	25 Year	50 Year	100 Year	500 Year
Design Storm Return Period									
One-Hour Rainfall Depth (in)	0.53	1.07	1.19	1.50	1.75	2.00	2.25	2.52	3.40
Calculated Runoff Volume (acre-ft)	0.006	0.018	0.014	0.020	0.031	0.054	0.069	0.089	0.138
OPTIONAL Override Runoff Volume (acre-ft)									
Inflow Hydrograph Volume (acre-ft)	0.006	0.018	0.013	0.019	0.031	0.053	0.068	0.088	0.137
Predevelopment Unit Peak Flow, q (cfs/acre)	0.00	0.00	0.02	0.03	0.29	0.90	1.24	1.64	2.62
Predevelopment Peak Q (cfs)	0.0	0.0	0.0	0.0	0.2	0.6	0.8	1.1	1.7
Peak Inflow Q (cfs)	0.1	0.4	0.3	0.4	0.7	1.2	1.6	2.0	3.2
Peak Outflow Q (cfs)	0.0	0.0	0.0	0.0	0.3	0.8	0.8	1.1	2.6
Ratio Peak Outflow to Predevelopment Q	N/A	N/A	N/A	1.2	1.7	1.3	1.0	1.0	1.5
Structure Controlling Flow	Filtration Media	Plate	Plate	Plate	Overflow Grate 1	Outlet Plate 1	Outlet Plate 1	Spillway	Spillway
Max Velocity through Grate 1 (fps)	N/A	N/A	N/A	N/A	0.0	0.1	0.1	0.1	0.1
Max Velocity through Grate 2 (fps)	N/A	N/A	N/A	N/A	N/A	N/A	N/A	N/A	N/A
Time to Drain 97% of Inflow Volume (hours)	12	23	21	24	25	24	23	22	19
Time to Drain 99% of Inflow Volume (hours)	12	24	21	25	27	26	26	26	25
Maximum Ponding Depth (ft)	0.35	0.98	0.76	1.02	1.30	1.42	1.70	2.04	2.15
Area at Maximum Ponding Depth (acres)	0.02	0.02	0.02	0.02	0.02	0.02	0.03	0.03	0.03
Maximum Volume Stored (acre-ft)	0.005	0.016	0.012	0.016	0.022	0.025	0.033	0.042	0.045

Detention Basin Outlet Structure Design

UD-Detention, Version 3.07 (February 2017)

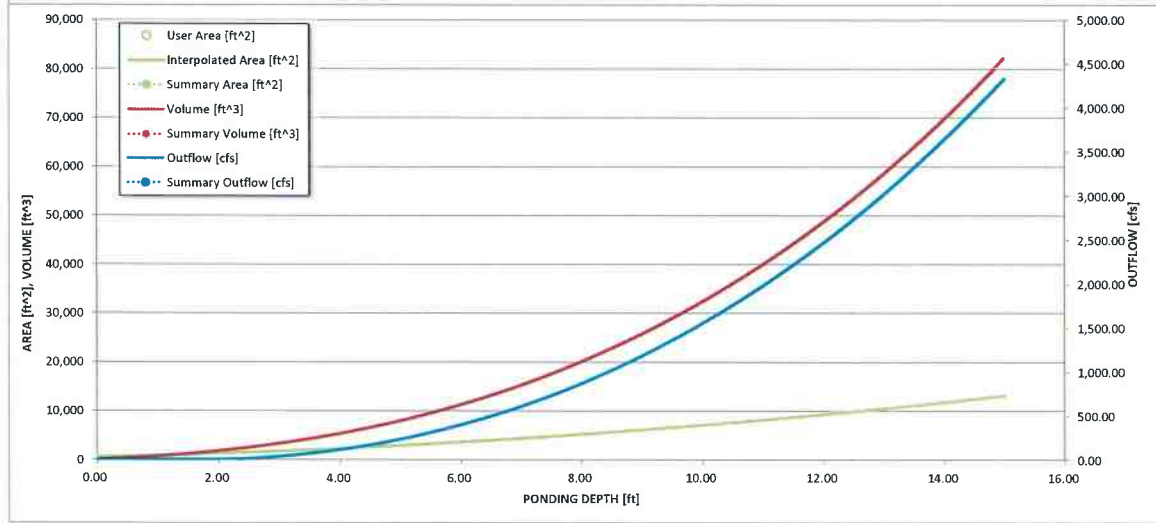
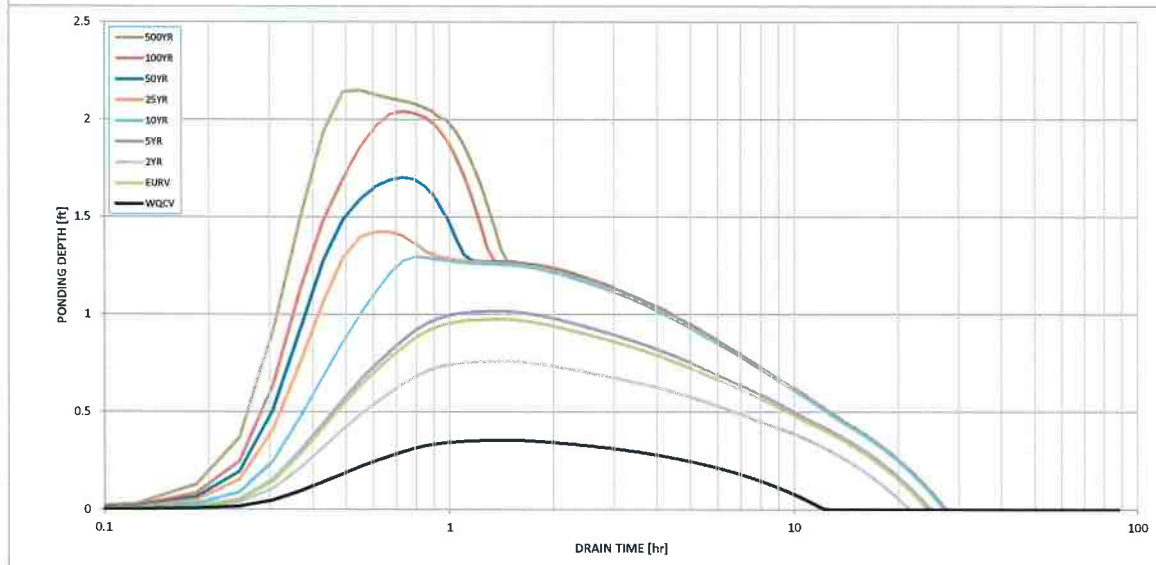
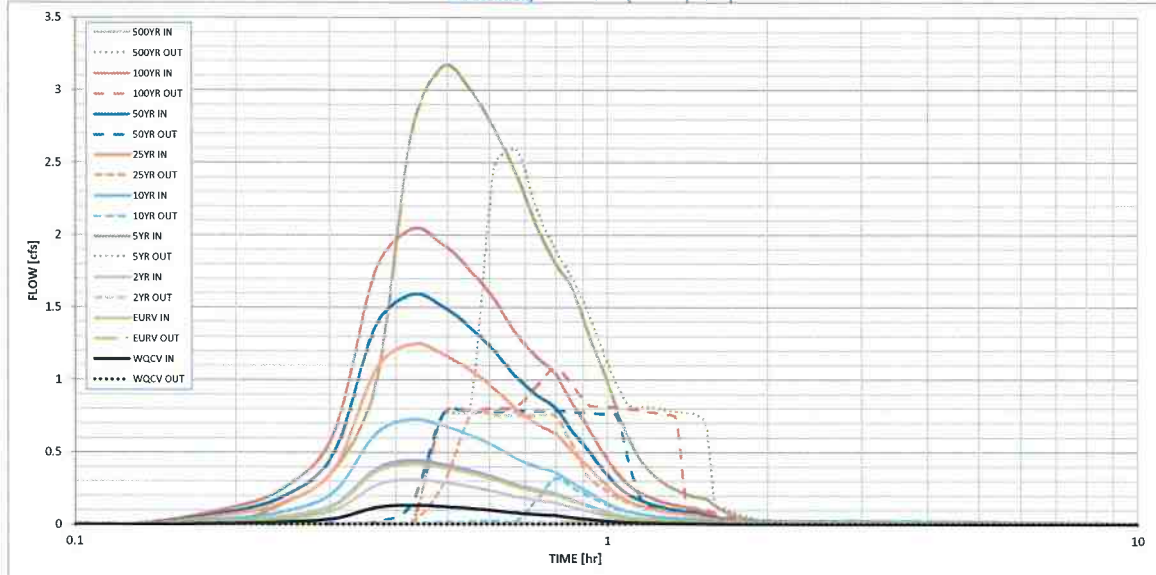

S-A-V-D Chart Axis Override

	X-axis	Left Y-Axis	Right Y-Axis
minimum bound			
maximum bound			

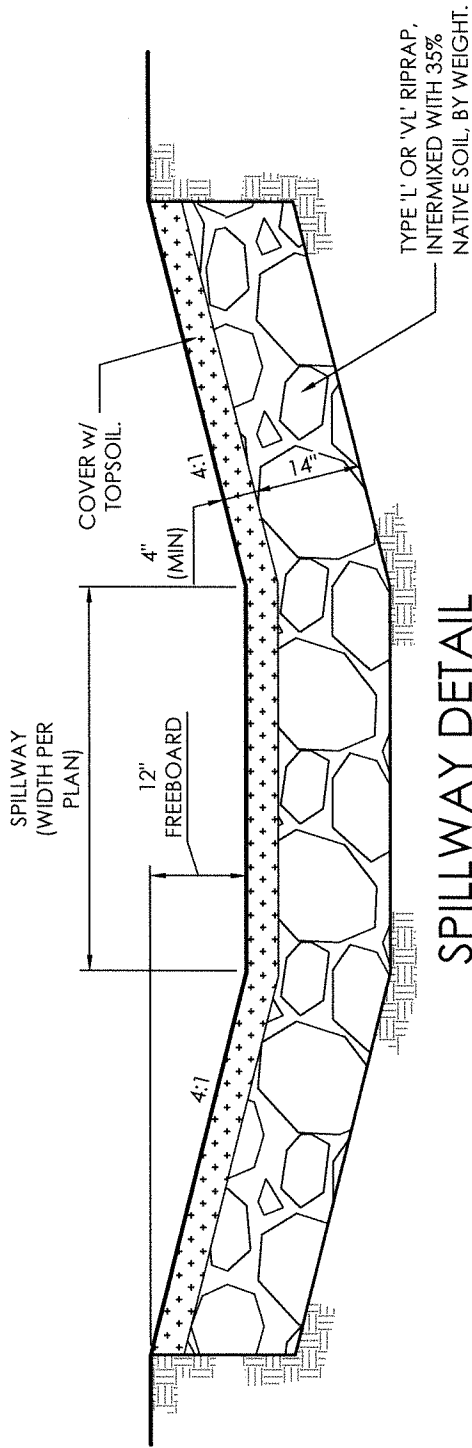

SPILLWAY DETAIL

SCALE: NTS

RIP-RAP GRADATION TABLE		
% SMALLER BY WEIGHT	TYPE VL INTER. ROCK DIM. (INCHES)	TYPE L INTER. ROCK DIM. (INCHES)
70 - 100	$d_{100} = 12$	$d_{100} = 15$
50 - 70	$d_{70} = 9$	$d_{70} = 12$
35 - 50	$d_{50} = 6$	$d_{50} = 9$
2 - 10	$d_{10} = 2$	$d_{10} = 3$

MONUMENT VALLEY ENGINEERS INC.

ENGINEERS * SURVEYORS
 1903 LELARAY STREET
 COLORADO SPRINGS, COLORADO 80909
 PHONE (719) 635-5736



PROJECT: SANCTUARY OF PEACE

TITLE: SAND FILTER BASIN

PROJ. NO. 61087

DATE: 1/10/2018

DRAWING NO. -SF-DET

SHEET 2 OF 2

CIRCULAR CONDUIT FLOW (Normal & Critical Depth Computation)

Project: **61087 - Sanctuary of Peace**

Pipe ID: **Culvert B1**

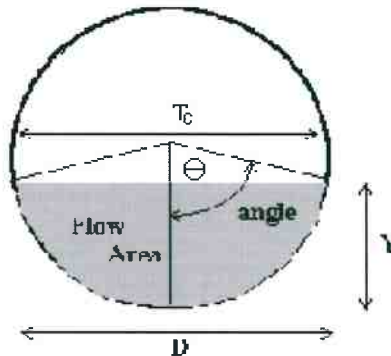

Design Information (Input)

Pipe Invert Slope	$S_o =$	0.0050	ft/ft
Pipe Manning's n-value	$n =$	0.0130	
Pipe Diameter	$D =$	18.00	inches
Design discharge	$Q =$	5.00	cfs

Full-flow Capacity (Calculated)

Full-flow area	$A_f =$	1.77	sq ft
Full-flow wetted perimeter	$P_f =$	4.71	ft
Half Central Angle	$\theta =$	3.14	radians
Full-flow capacity	$Q_f =$	7.45	cfs

Calculation of Normal Flow Condition

Half Central Angle ($0 < \theta < 3.14$)	$\theta =$	1.77	radians
Flow area	$A_n =$	1.11	sq ft
Top width	$T_n =$	1.47	ft
Wetted perimeter	$P_n =$	2.66	ft
Flow depth	$Y_n =$	0.90	ft
Flow velocity	$V_n =$	4.52	fps
Discharge	$Q_n =$	5.00	cfs
Percent Full Flow	$\text{Flow} =$	67.1%	of full flow
Normal Depth Froude Number	$Fr_n =$	0.92	subcritical

Calculation of Critical Flow Condition

Half Central Angle ($0 < \theta_c < 3.14$)	$\theta_c =$	1.72	radians
Critical flow area	$A_c =$	1.05	sq ft
Critical top width	$T_c =$	1.48	ft
Critical flow depth	$Y_c =$	0.86	ft
Critical flow velocity	$V_c =$	4.77	fps
Critical Depth Froude Number	$Fr_c =$	1.00	

Determination of Culvert Headwater and Outlet Protection

Project: **61087 - Sanctuary of Peace**

Basin ID: **Culvert B1**

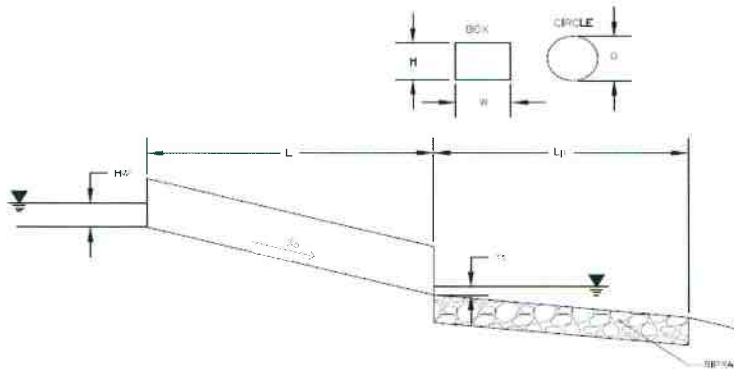

Soil Type:

Choose One:
 Sandy
 Non-Sandy

Design Information (Input):

Design Discharge

Q = cfs

Circular Culvert:

Barrel Diameter in Inches

D = inches

Inlet Edge Type (Choose from pull-down list)

1.5 : 1 Beveled Edge

Box Culvert:

Barrel Height (Rise) in Feet

Height (Rise) = ft

Barrel Width (Span) in Feet

Width (Span) = ft

Inlet Edge Type (Choose from pull-down list)

Number of Barrels

No =

Inlet Elevation

Elev IN = ft

Outlet Elevation OR Slope

So = ft/ft

Culvert Length

L = ft

Manning's Roughness

n =

Bend Loss Coefficient

k_b =

Exit Loss Coefficient

k_x =

Tailwater Surface Elevation

Elev Y_t = ft

Max Allowable Channel Velocity

V = ft/s

Required Protection (Output):

Tailwater Surface Height

Y_t = ft

Flow Area at Max Channel Velocity

A_c = ft²

Culvert Cross Sectional Area Available

A = ft²

Entrance Loss Coefficient

k_e =

Friction Loss Coefficient

k_f =

Sum of All Losses Coefficients

k_s = ft

Culvert Normal Depth

Y_n = ft

Culvert Critical Depth

Y_c = ft

Tailwater Depth for Design

d = ft

Adjusted Diameter OR Adjusted Rise

D_a = ft

Expansion Factor

$1/(2*\tan(\theta))$ =

Flow/Diameter^{2.5} OR Flow/(Span * Rise^{1.5})

$Q/D^{2.5}$ = ft^{0.5}/s

Froude Number

Fr =

Tailwater/Adjusted Diameter OR Tailwater/Adjusted Rise

YVD =

Inlet Control Headwater

HW_i = ft

Outlet Control Headwater

HW_o = ft

Design Headwater Elevation

HW = ft

Headwater/Diameter OR Headwater/Rise Ratio

HW/D =

Minimum Theoretical Riprap Size

d_{50} = in

Nominal Riprap Size

d_{50} = in

UDFCD Riprap Type

Type =

Length of Protection

L_p = ft

Width of Protection

T = ft

Sub-Basin C1 (Culvert) Runoff Calculations

Job No.: 61087
 Project: Sanctuary of Peace
 Jurisdiction: DCM
 Runoff Coefficient: Surface Type

Date: 9/16/2019 10:38
 Calcs by: ASM
 Checked by: _____
 Soil Type: B
 Urbanization: Non-Urban

Basin Land Use Characteristics

Surface	Area		Runoff Coefficient						% Imperv.
	(SF)	(Acres)	C2	C5	C10	C25	C50	C100	
Forest	74,698	1.71	0.02	0.08	0.15	0.25	0.3	0.35	0%
Driveways & Walks	5,171	0.12	0.89	0.9	0.92	0.94	0.95	0.96	100%
Roofs	15,854	0.36	0.71	0.73	0.75	0.78	0.8	0.81	90%
Combined	95,723	2.20	0.18	0.23	0.29	0.38	0.42	0.46	20.3%

95723

Basin Travel Time

Shallow Channel Ground Cover Forest						
	$L_{max,Overland}$	100 ft			C_v	5
	L (ft)	ΔZ_0 (ft)	S_0 (ft/ft)	v (ft/s)	t (min)	t_{Att} (min)
Total	367	25	-	-	-	-
Initial Time	100	16	0.160	-	6.3	N/A DCM Eq. 6-8
Shallow Channel	267	9	0.034	0.9	4.8	- DCM Eq. 6-9
Channelized			0.000	0.0	0.0	- V-Ditch
				t_c	11.1 min.	

Rainfall Intensity & Runoff

	2-Yr	5-Yr	10-Yr	25-Yr	50-Yr	100-Yr
Intensity (in/hr)	3.17	3.97	4.63	5.29	5.95	6.66
Runoff (cfs)	1.3	2.0	3.0	4.4	5.5	6.7
Release Rates (cfs/ac)	-	-	-	-	-	-
Allowed Release (cfs)	1.3	2.0	3.0	4.4	5.5	6.7

DCM: $t = C1 * \ln(t_c) + C2$

C1	1.19	1.5	1.75	2	2.25	2.52
C2	6.035	7.583	8.847	10.111	11.375	12.735

Notes

CIRCULAR CONDUIT FLOW (Normal & Critical Depth Computation)

Project: 61087 - Sanctuary of Peace

Pipe ID: Culvert C1

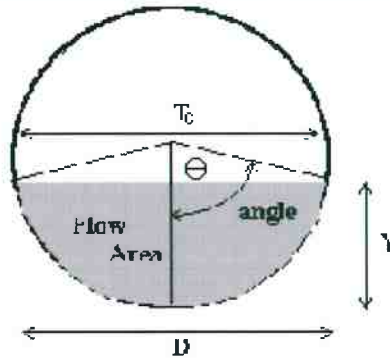

Design Information (Input)

Pipe Invert Slope	$S_o =$	0.0050	ft/ft
Pipe Manning's n-value	$n =$	0.0130	
Pipe Diameter	$D =$	18.00	inches
Design discharge	$Q =$	6.70	cfs

Full-flow Capacity (Calculated)

Full-flow area	$A_f =$	1.77	sq ft
Full-flow wetted perimeter	$P_f =$	4.71	ft
Half Central Angle	$\theta =$	3.14	radians
Full-flow capacity	$Q_f =$	7.45	cfs

Calculation of Normal Flow Condition

Half Central Angle ($0 < \theta < 3.14$)	$\theta =$	2.07	radians
Flow area	$A_n =$	1.40	sq ft
Top width	$T_n =$	1.31	ft
Wetted perimeter	$P_n =$	3.11	ft
Flow depth	$Y_n =$	1.11	ft
Flow velocity	$V_n =$	4.77	fps
Discharge	$Q_n =$	6.70	cfs
Percent Full Flow	$\text{Flow} =$	89.9%	of full flow
Normal Depth Froude Number	$Fr_n =$	0.81	subcritical

Calculation of Critical Flow Condition

Half Central Angle ($0 < \theta_c < 3.14$)	$\theta_c =$	1.91	radians
Critical flow area	$A_c =$	1.25	sq ft
Critical top width	$T_c =$	1.41	ft
Critical flow depth	$Y_c =$	1.00	ft
Critical flow velocity	$V_c =$	5.34	fps
Critical Depth Froude Number	$Fr_c =$	1.00	

Determination of Culvert Headwater and Outlet Protection

Project: **61087 - Sanctuary of Peace**

Basin ID: **Culvert C1**

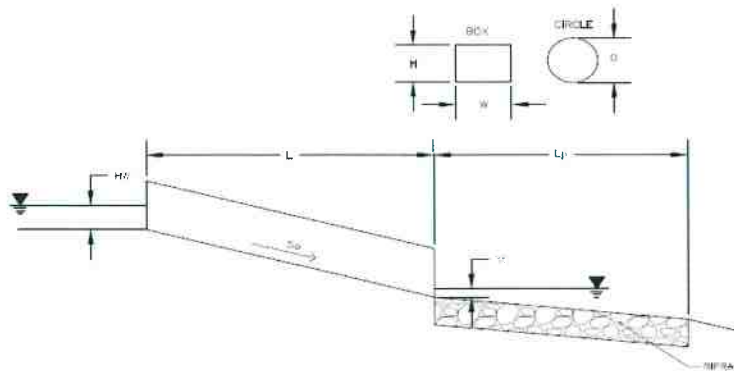

Soil Type: _____

Choose One:
 Sandy
 Non-Sandy

Design Information (Input):

Design Discharge

Q = cfs

Circular Culvert:

Barrel Diameter in Inches

D = inches

Inlet Edge Type (Choose from pull-down list)

1.5 : 1 Beveled Edge

OR

Box Culvert:

Barrel Height (Rise) in Feet

Height (Rise) = ft

Barrel Width (Span) in Feet

Width (Span) = ft

Inlet Edge Type (Choose from pull-down list)

Number of Barrels

No =

Inlet Elevation

Elev IN = ft

Outlet Elevation OR Slope

So = ft/ft

Culvert Length

L = ft

Manning's Roughness

n =

Bend Loss Coefficient

k_b =

Exit Loss Coefficient

k_x =

Tailwater Surface Elevation

Elev Y_t = ft

Max Allowable Channel Velocity

V = ft/s

Required Protection (Output):

Tailwater Surface Height

Y_t = ft

Flow Area at Max Channel Velocity

A_v = ft²

Culvert Cross Sectional Area Available

A = ft²

Entrance Loss Coefficient

k_e =

Friction Loss Coefficient

k_f =

Sum of All Losses Coefficients

k_s = ft

Culvert Normal Depth

Y_n = ft

Culvert Critical Depth

Y_c = ft

Tailwater Depth for Design

d = ft

Adjusted Diameter OR Adjusted Rise

D_a = ft

Expansion Factor

1/(2*tan(θ)) =

Flow/Diameter^{2.5} OR Flow/(Span * Rise^{1.5})

Q/D^{2.5} = ft^{0.5}/s

Froude Number

Fr =

Tailwater/Adjusted Diameter OR Tailwater/Adjusted Rise

Y/D =

Inlet Control Headwater

HW_i = ft

Outlet Control Headwater

HW_o = ft

Design Headwater Elevation

HW = ft

Headwater/Diameter OR Headwater/Rise Ratio

HW/D =

Minimum Theoretical Riprap Size

d₅₀ = in

Nominal Riprap Size

d₅₀ = in

UDFCD Riprap Type

Type =

Length of Protection

L_p = ft

Width of Protection

T = ft

4 Drainage Maps

Existing Conditions Drainage Map
Proposed Conditions Drainage Map

(Map Pocket)
(Map Pocket)

EXISTING DRAINAGE SUMMARY TABLE					
DESIGN POINT	BASIN	AREA (AC)	Tc (MIN.)	RUNOFF	
				Q5 (CFS)	Q100 (CFS)
	OS A	69.40	41.9	11.4	81.1
	OS B	83.92	41.7	17.4	102.7
	EX-A1	30.11	23.3	6.9	50.6
EX1	OS A, OS B, EX-A1	153.32	41.9	35.7	234.4
	EX-C1	5.68	15.7	1.6	11.5
EX7	EX-C1	5.68	15.7	1.6	11.5
	EX-C2	2.03	10.9	0.7	4.8
EX4	EX-C2	2.03	10.9	0.7	4.8
	EX-C3	0.66	9.8	0.2	1.6
EX5	EX-C3	0.66	9.8	0.2	1.6
	EX-B1	2.06	14.4	0.6	4.3
EX8	EX-B1	2.06	14.4	0.6	4.3
	EX-B2	8.75	12.0	2.7	19.8
	OS C	49.12	23.9	16.6	88.1
EX9	EX-B1, EX-B2, OS C	59.93	23.9	19.0	106.0

LEGEND

PROPERTY LINE
 EASEMENT LINE
 LOT LINE

EXISTING

INDEX CONTOUR
 INTERMEDIATE CONTOUR

PROPOSED

INDEX CONTOUR
 INTERMEDIATE CONTOUR

BASIN BOUNDARY

GENERAL FLOW/DIRECTION
 SLOPE DIRECTION AND GRADE

BASIN LABEL
 AREA IN ACRES
 PERCENT IMPERVIOUS

POINT OF INTEREST

FLOODPLAIN STATEMENT:
 NO PORTION OF THE SUBJECT PROPERTY IS LOCATED WITHIN A FEMA DESIGNATED SPECIAL FLOOD HAZARD AREA (SFHA) AS INDICATED ON THE FLOOD INSURANCE RATE MAP (FIRM) FOR EL PASO COUNTY, COLORADO AND INCORPORATED AREAS - MAP NUMBER 08041C0295 G, EFFECTIVE DECEMBER 7, 2018.

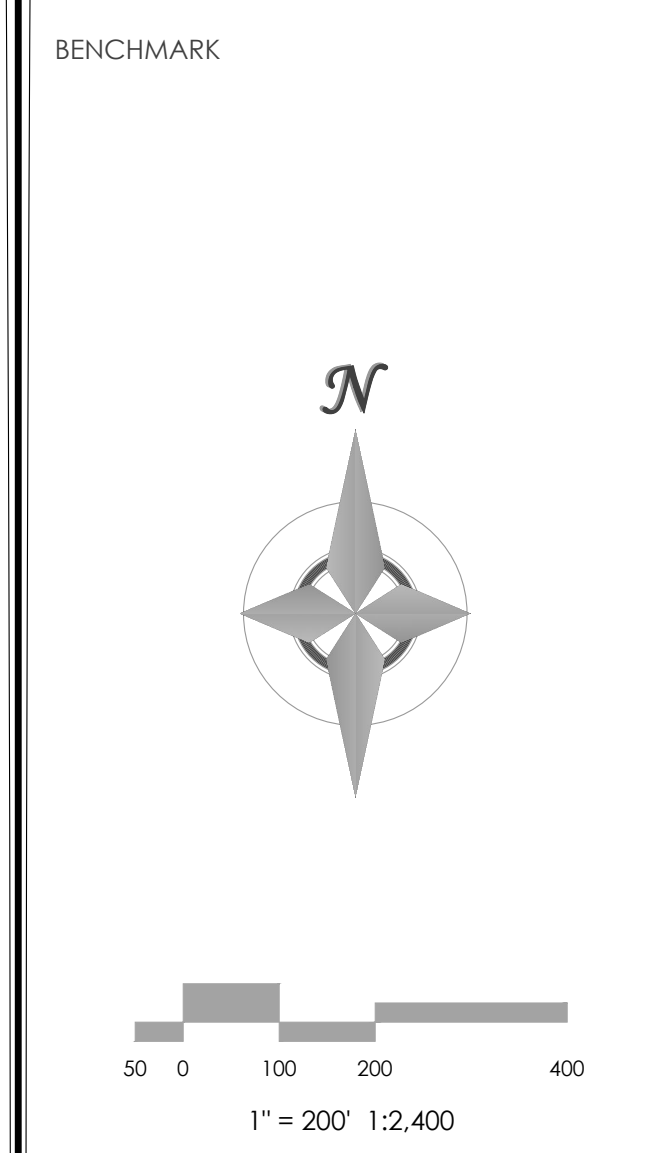
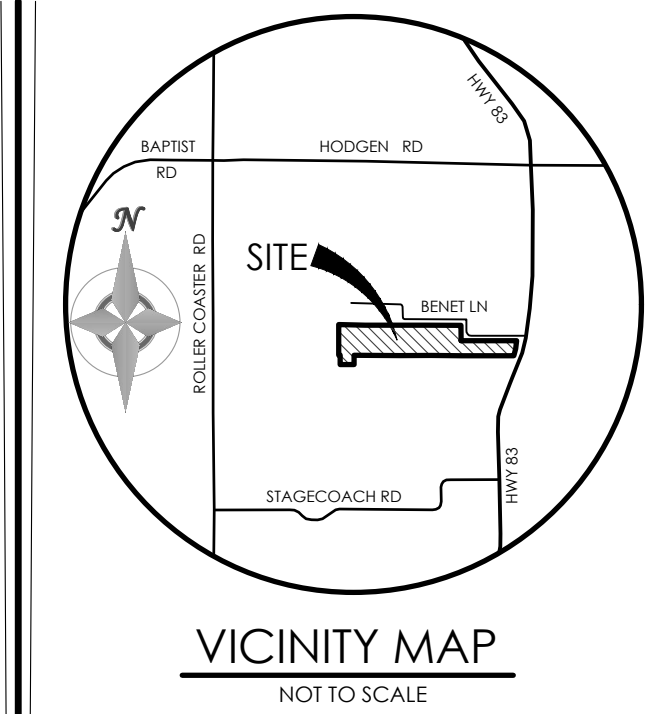
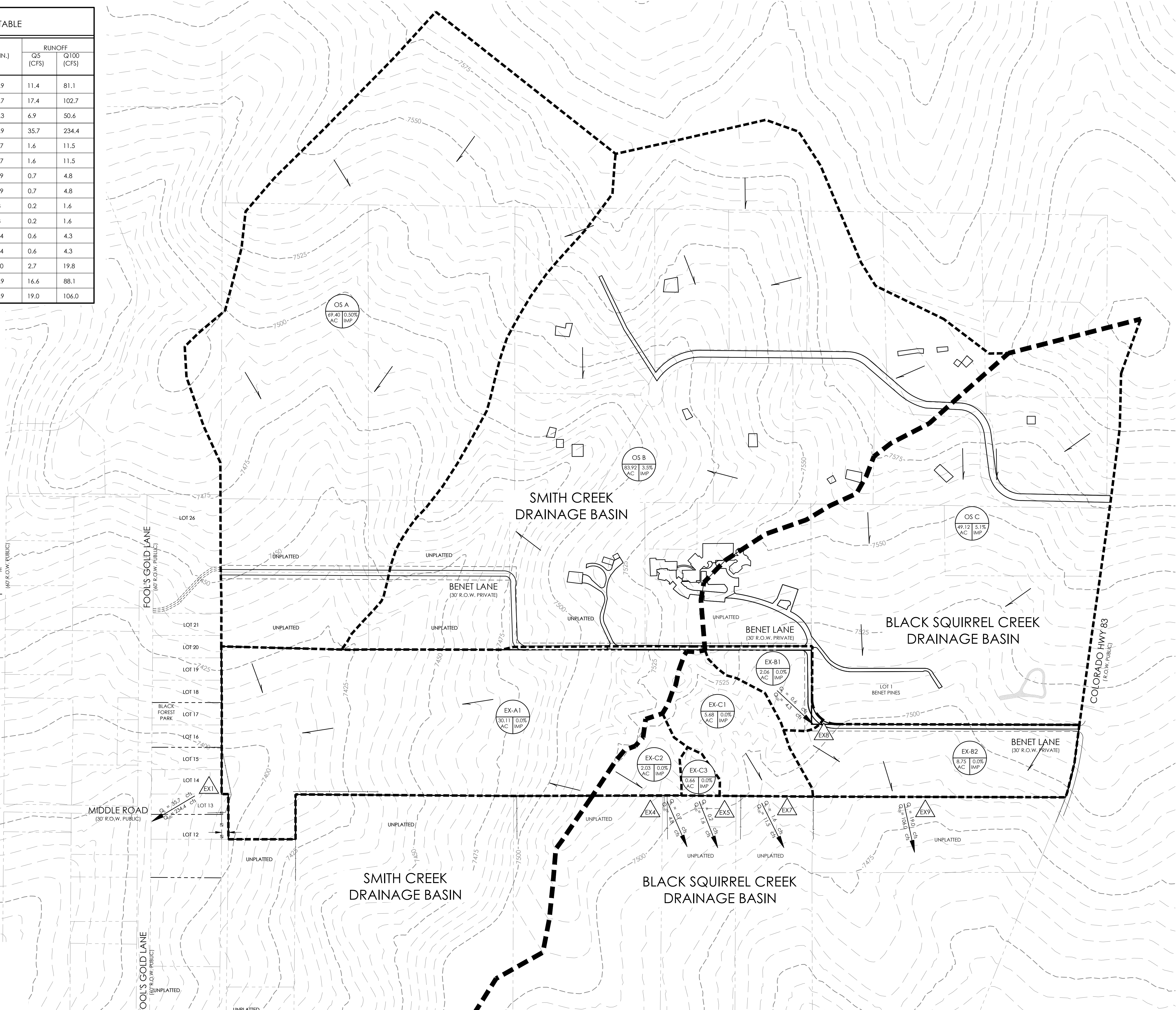

MVE INC.
 ENGINEERS / SURVEYORS

1903 Leary Street, Suite 200 Colorado Springs, CO 80909 719.635.5726

DESIGNED BY
 DRAWN BY
 CHECKED BY
 AS-BUILT BY
 CHECKED BY

SANCTUARY OF PEACE

EXISTING DRAINAGE MAP

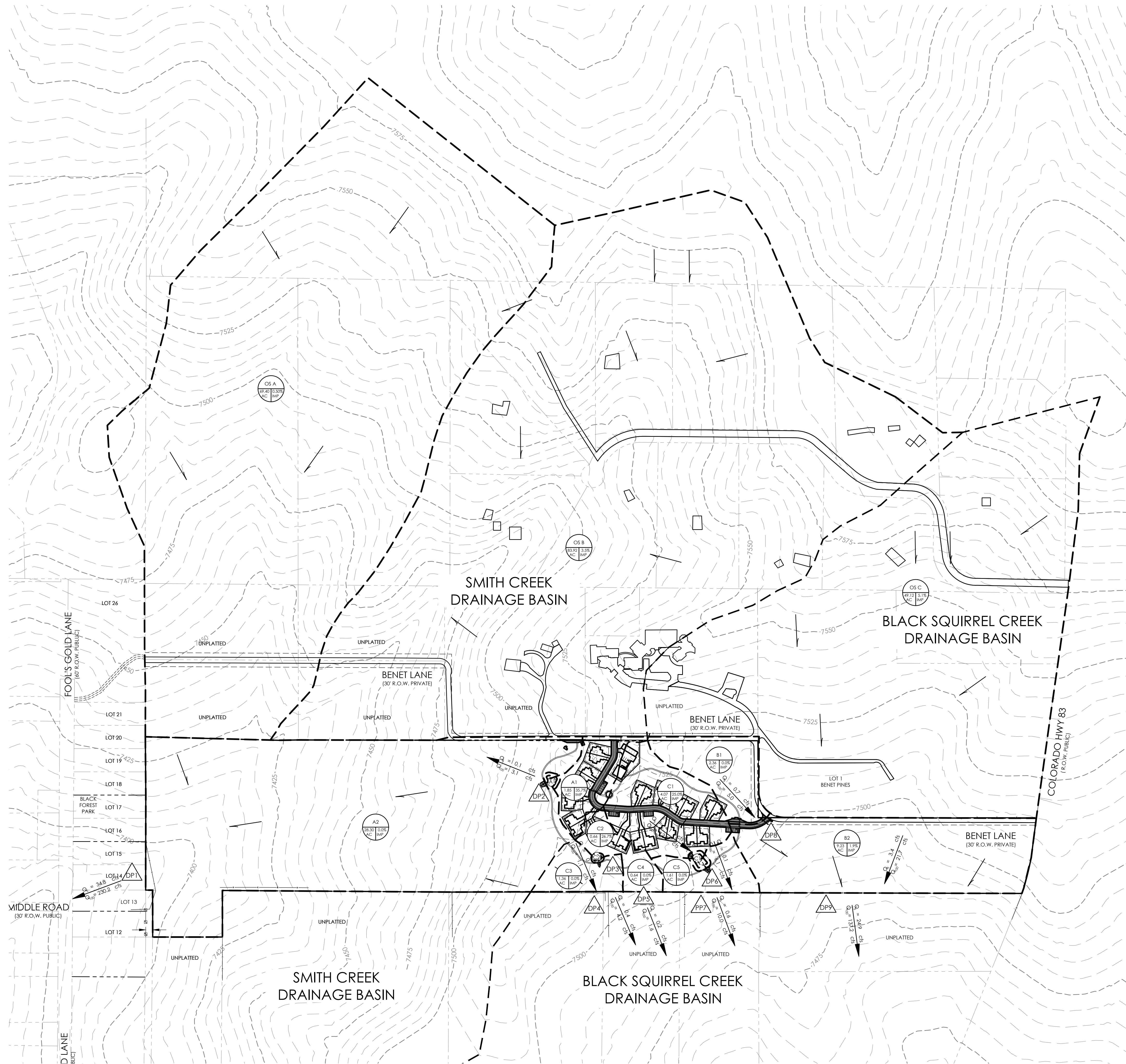

DEVELOPED DRAINAGE SUMMARY TABLE

DESIGN POINT	BASIN	AREA (AC)	Tc (MIN)	RUNOFF	
				Q5 (CFS)	Q100 (CFS)
	OS A	69.40	41.9	11.4	81.1
	OS B	83.92	41.7	17.4	102.7
	A1	1.85	9.1	2.8	7.3
	A2	28.30	27.7	5.9	43.3
DP1	OS A, OS B, DP2, A2	183.47	41.9	34.8	230.2
DP2 In	A1	1.85	9.1	2.8	7.3
DP2 Out	A1	1.85	9.1	0.1	3.1
	C2	0.66	8.8	0.8	2.4
DP3 In	C2	0.66	8.8	0.8	2.4
DP3 Out	C2	0.66	8.8	0.0	1.1
	C3	1.36	11.8	0.4	3.1
DP4	C2, C3	2.02	11.8	0.4	4.2
	C4	0.64	8.8	0.2	1.6
DP5	C4	0.64	8.8	0.2	1.6
	C1	4.07	13.1	4.1	12.5
DP6 In	C1	4.07	13.1	4.1	12.5
DP6 Out	C1	4.07	13.1	0.1	6.1
	C5	1.61	10.2	0.5	3.9
DP7	C1, C5	5.69	13.1	0.6	10.0
	B1	2.36	14.4	0.7	5.0
DP8	B1	2.36	14.4	0.7	5.0
	B2	9.23	11.8	3.4	21.7
	OS C	49.12	23.9	16.6	88.1
DP9	B1, B2, OS C	60.72	14.4	24.9	137.2

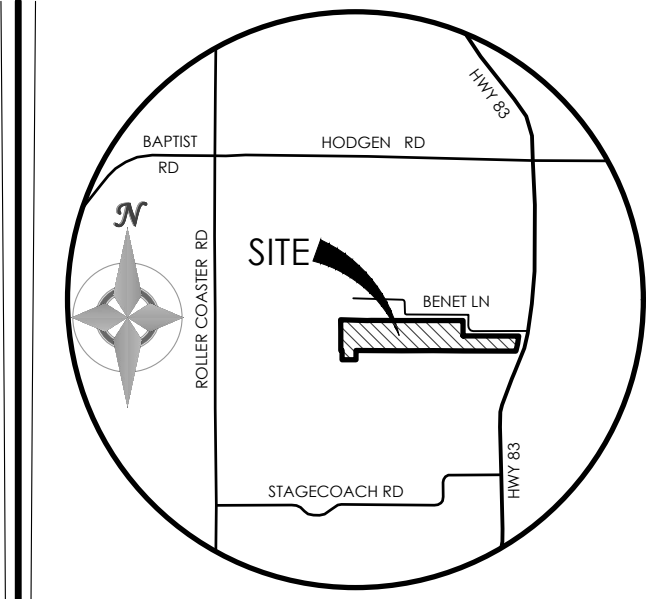

VICINITY MAP
NOT TO SCALE

BENCHMARK

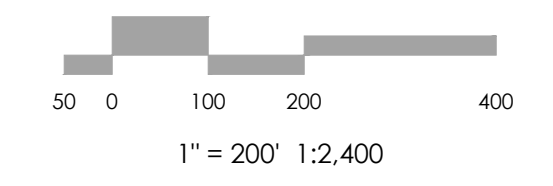
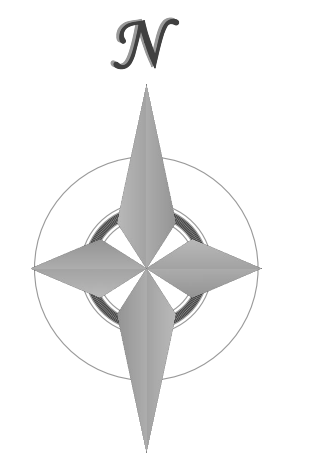

- LEGEND**
- PROPERTY LINE
 - - - EASEMENT LINE
 - LOT LINE
 - INDEX CONTOUR
 - - - INTERMEDIATE CONTOUR
 - PROPOSED INDEX CONTOUR
 - - - PROPOSED INTERMEDIATE CONTOUR
 - BASIN BOUNDARY
 - GENERAL FLOW/DIRECTION
 - SLOPE DIRECTION AND GRADE
 - BASIN LABEL
 - AREA IN ACRES
 - PERCENT IMPERVIOUS
 - POINT OF INTEREST
 - FULL SPECTRUM SAND FILTER BASIN (FSSFB)

FLOODPLAIN STATEMENT:
NO PORTION OF THE SUBJECT PROPERTY IS LOCATED WITHIN A FEMA DESIGNATED SPECIAL FLOOD HAZARD AREA (SFHA) AS INDICATED ON THE FLOOD INSURANCE RATE MAP (FIRM) FOR EL PASO COUNTY, COLORADO AND INCORPORATED AREAS - MAP NUMBER 08041C0295 G, EFFECTIVE DECEMBER 7, 2018.

WATER QUALITY BASIN NOTES
THE FULL SPECTRUM SAND FILTER BASINS A1, B1, AND C1 SHALL BE ESTABLISHED IN THE FIELD BY THE PROJECT ENGINEER AT OR ABOVE THE CALCULATED REQUIRED VOLUME.
THE FULL SPECTRUM SAND FILTER BASINS SHALL BE FIELD SURVEYED FOR AS-BUILT CONDITIONS AND APPROVED BY THE PROJECT ENGINEER AS BEING CONSTRUCTED IN SUBSTANTIAL COMPLIANCE WITH APPROVED DETAILS FOR CONSTRUCTION.

REVISIONS

DESIGNED BY _____
DRAWN BY _____
CHECKED BY _____
AS-BUILTS BY _____
CHECKED BY _____
SANCTUARY OF PEACE

PROPOSED DRAINAGE MAP

MVE PROJECT **61087**
MVE DRAWING **PP-DM**

April 28, 2020
SHEET 1 OF 1

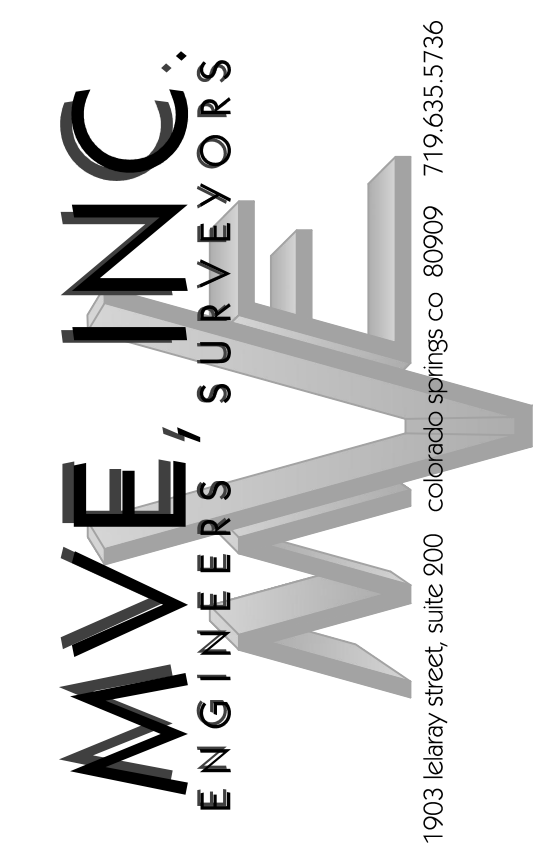

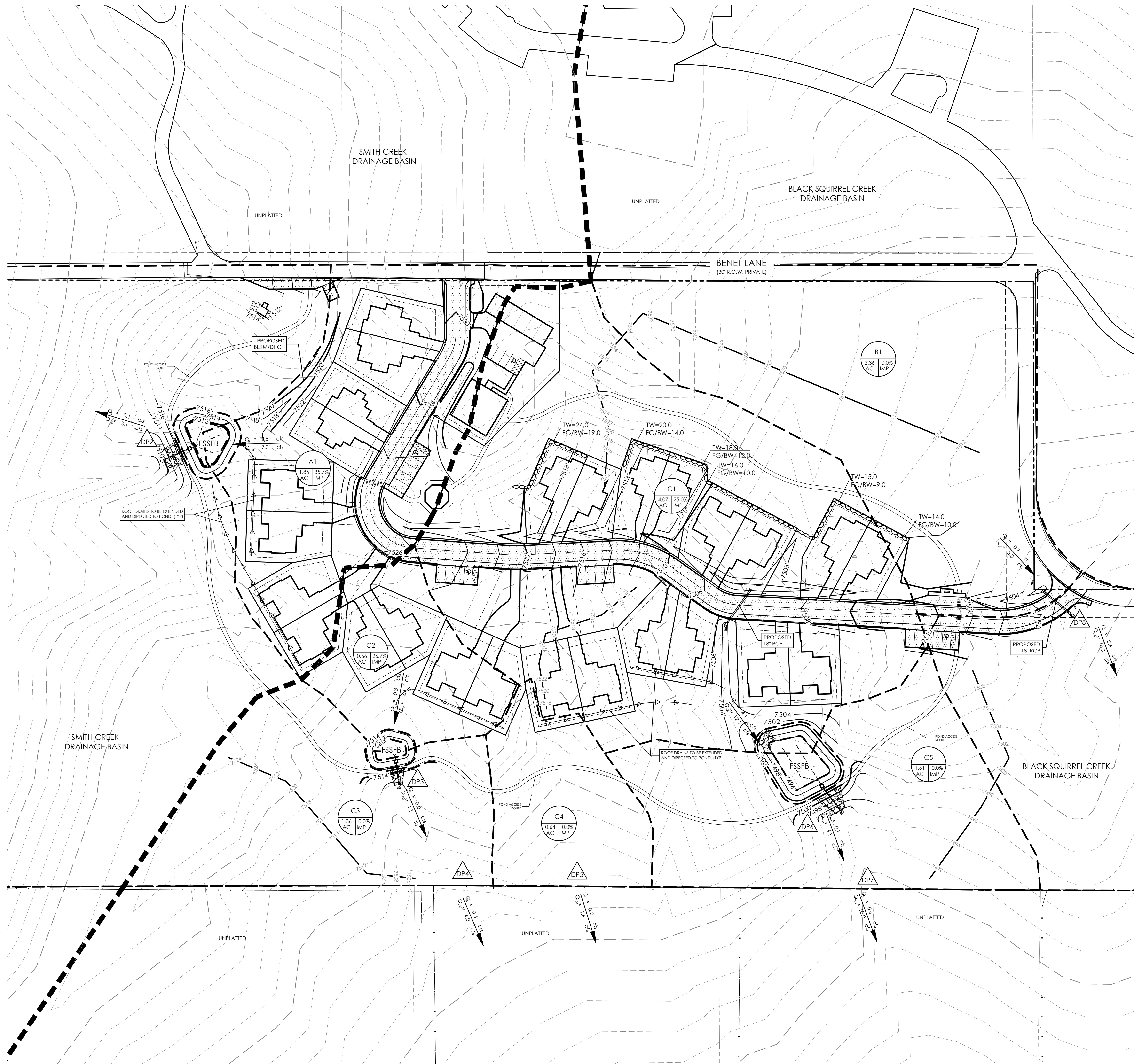

LEGEND

---	PROPERTY LINE
- - - -	EASEMENT LINE
---	LOT LINE
EXISTING	
- - - -	INDEX CONTOUR
- - - -	INTERMEDIATE CONTOUR
PROPOSED	
- - - -	INDEX CONTOUR
- - - -	INTERMEDIATE CONTOUR
---	BASIN BOUNDARY
→	GENERAL FLOW/DIRECTION
1.5%	SLOPE DIRECTION AND GRADE
A1	BASIN LABEL AREA IN ACRES PERCENT IMPERVIOUS
△	POINT OF INTEREST
⊙	FULL SPECTRUM SAND FILTER BASIN (FSSFB)

FLOODPLAIN STATEMENT:
 NO PORTION OF THE SUBJECT PROPERTY IS LOCATED WITHIN A FEMA DESIGNATED SPECIAL FLOOD HAZARD AREA (SFHA) AS INDICATED ON THE FLOOD INSURANCE RATE MAP (FIRM) FOR EL PASO COUNTY, COLORADO AND INCORPORATED AREAS - MAP NUMBER 08041 C0295 G, EFFECTIVE DECEMBER 7, 2018.

WATER QUALITY BASIN NOTES
 THE FULL SPECTRUM SAND FILTER BASINS A1, B1, AND C1 SHALL BE ESTABLISHED IN THE FIELD BY THE PROJECT ENGINEER AT OR ABOVE THE CALCULATED REQUIRED VOLUME. THE FULL SPECTRUM SAND FILTER BASINS SHALL BE FIELD SURVEYED FOR AS-BUILT CONDITIONS AND APPROVED BY THE PROJECT ENGINEER AS BEING CONSTRUCTED IN SUBSTANTIAL COMPLIANCE WITH APPROVED DETAILS FOR CONSTRUCTION.

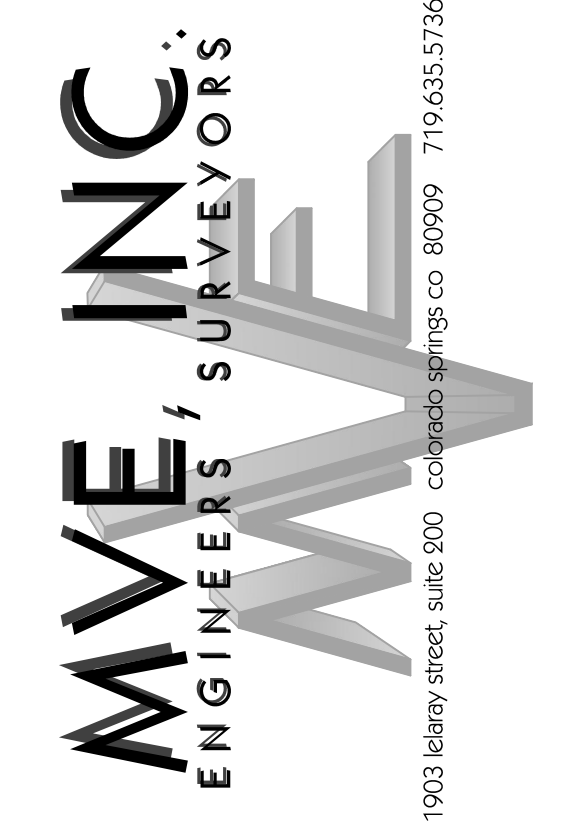
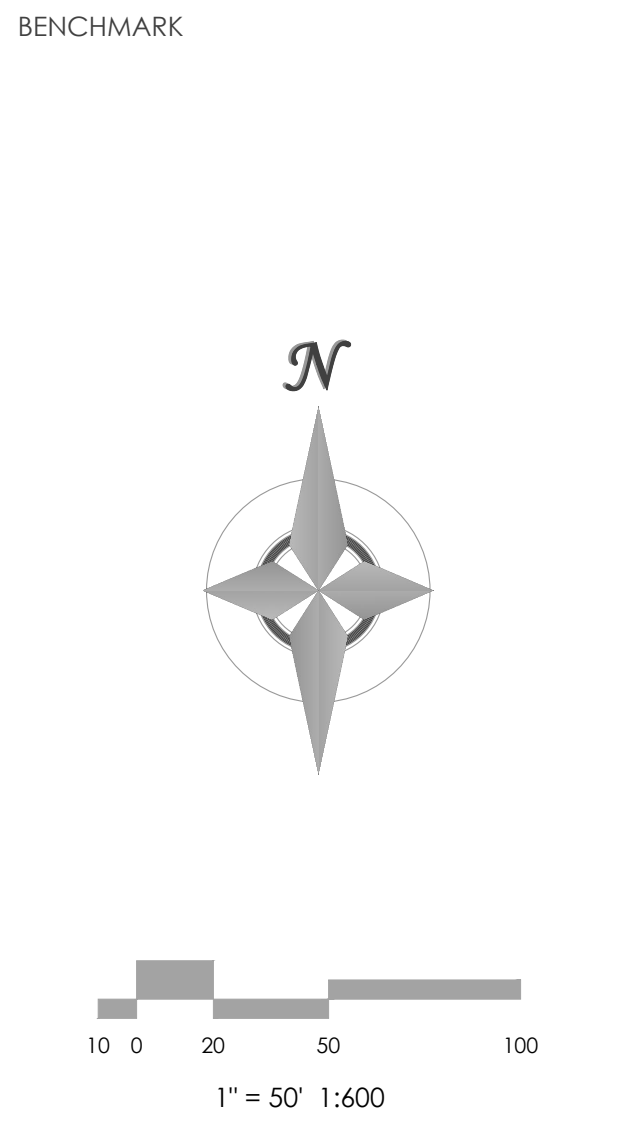
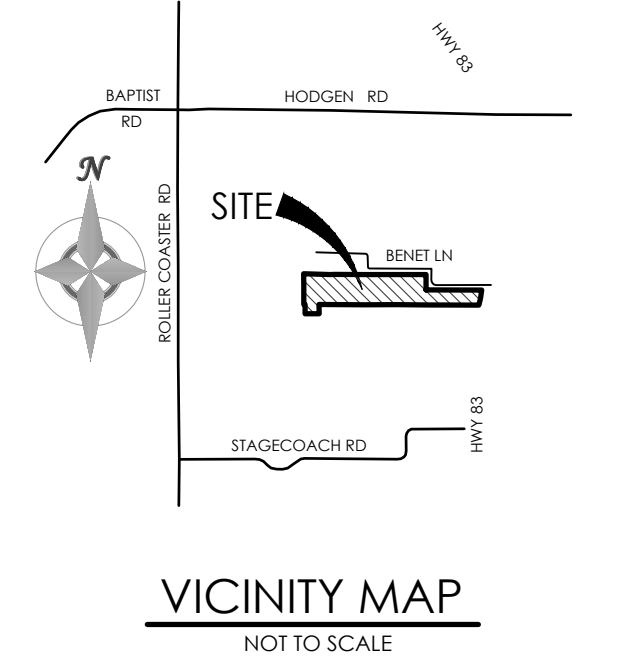

REVISIONS

DESIGNED BY _____
 DRAWN BY _____
 CHECKED BY _____
 AS-BUILTS BY _____
 CHECKED BY _____

SANCTUARY OF PEACE

PROPOSED DRAINAGE MAP (DETAIL)