



ENTECH
ENGINEERING, INC.

505 ELKTON DRIVE
COLORADO SPRINGS, CO 80907
PHONE (719) 531-5599
FAX (719) 531-5238

**SOIL, GEOLOGY AND GEOLOGIC HAZARD STUDY
SANCTUARY OF PEACE FILING NO. 1
15760 HIGHWAY 83 AND BENET LANE
EL PASO COUNTY, COLORADO**

Prepared for

MVE, Inc.
1903 Lelaray Street, Suite 200
Colorado Springs, Colorado 80909

Attn: Charles C. Crum

PUDSP-19-002

Provide an exhibit in this report that shows the area that is described on page 8 as unstable due to the Benet Lane road cut. Additionally call out proposed mitigation for this area to support the housing development.

February 11, 2019

Respectfully Submitted,

ENTECH ENGINEERING, INC.

Kristen A. Andrew-Hoeser, P.G.
Engineering Geologist

Logan L. Langford, P.G.
Geologist

KAH/LLL

Encl.

Entech Job No. 190118
AAprojects/2019/190118 countysoil/geo

Reviewed by:

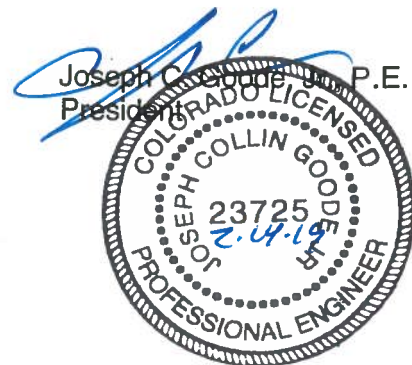

TABLE OF CONTENTS

1.0 SUMMARY 1

2.0 GENERAL SITE CONDITIONS AND PROJECT DESCRIPTION2

3.0 SCOPE OF THE REPORT2

4.0 FIELD INVESTIGATION3

5.0 SOIL, GEOLOGY AND ENGINEERING GEOLOGY.....3

 5.1 General Geology3

 5.2 Soil Conservation Survey.....4

 5.3 Site Stratigraphy.....4

 5.4 Soil Conditions5

 5.5 Groundwater5

6.0 ENGINEERING GEOLOGY – IDENTIFICATION AND MITIGATION OF GEOLOGIC HAZARDS.....5

 6.1 Relevance of Geologic Conditions to Land Use Planning8

7.0 ECONOMIC MINERAL RESOURCES.....9

8.0 EROSION CONTROL 10

9.0 CLOSURE 11

BIBLIOGRAPHY..... 12

FIGURES

- Figure 1: Vicinity Map
- Figure 2: USGS Map
- Figure 3: Site Plan
- Figure 4: Soil Survey Map
- Figure 5: Monument Quadrangle Geology Map
- Figure 6: Geology Map/Engineering Geology
- Figure 7: Floodplain Map
- Figure 8: Typical Perimeter Drain Details

- APPENDIX A: Site Photographs
- APPENDIX B: Profile Holes from 285 Engineering
- APPENDIX C: Soil Survey Descriptions

1.0 SUMMARY

Project Location

The project lies in a portion of the S½ of Section 27, Township 11 South, Range 66 West of the 6th Principal Meridian in El Paso County, Colorado. The site is located south of Benet Lane and west of Highway 83, approximately 2 miles east of Monument, Colorado.

Project Description

Total acreage involved in the project is approximately 50 acres. A private residential development is proposed consisting of thirteen (13) duplex structures on the central portion of the property. The development will utilize a private water system with a well and water storage and on-site wastewater treatment systems.

Scope of Report

This report presents the results of our geologic evaluation, treatment of engineering geologic hazard study. This report presents results of out geologic reconnaissance, a review of available maps, aerial photographs, and our conclusions with respect to the impacts of the geologic conditions on the proposed development.

Land Use and Engineering Geology

This site was found to be suitable for the proposed development. Areas were encountered where the geologic conditions will impose some constraints on development and land use. These include areas of potentially seasonal shallow groundwater a potentially unstable slope (road cut) and the potential for sporadic expansive soils. Based on the proposed development plan, it appears that these areas will have some minor impacts on the development. These conditions will be discussed in greater detail in the report.

In general, it is our opinion that the development can be achieved if the observed geologic conditions on site are either avoided or properly mitigated. All recommendations are subject to the limitations discussed in the report.

2.0 GENERAL SITE CONDITIONS AND PROJECT DESCRIPTION

The site is located in a portion of the S½ of Section 27, Township 11 South, Range 66 West of the 6th Principal Meridian in El Paso County, Colorado. The site is located approximately 2 miles east of Monument, Colorado, south of Benet Lane and west of Highway 83. The location of the site is as shown on the Vicinity Map, Figure 1.

The topography of the site is gradually to moderately sloping generally to the southeast and southwest off a central ridgeline that bisects the site. A drainage exists in the far western portion of the site that flows in a southwesterly direction through the extreme western portion of the site. The site was snow covered at the time of this investigation, however, aerial photographs indicate the drainage is dry except perhaps during period of high moisture. The site boundaries are indicated on the USGS Map, Figure 2. Previous land uses have included grazing and open space and the Benet Hill Monastery Complex lies immediately north of the site. The site contains primarily ponderosa pines. Site photographs, taken January 31, 2019, are included in Appendix A.

Total acreage involved in the proposed development is approximately 50 acres. Thirteen residential duplex structures are proposed in the central portion of the site. The area will be serviced by a private water system with a well and water storage and on-site wastewater treatment systems. The Onsite Wastewater Treatment System Design was prepared by 285 Engineering June 18, 2018 (Reference 1). The Site Plan is presented in Figure 3.

3.0 SCOPE OF THE REPORT

The scope of the report will include the following:

- A general geologic analysis utilizing published geologic data. Detailed site-specific mapping will be conducted to obtain general information in respect to major geographic and geologic features, geologic descriptions and their effects on the development of the property.

4.0 FIELD INVESTIGATION

Our field investigation consisted of the preparation of a geologic map of any bedrock features and significant surficial deposits. The Natural Resource Conservation Service (NRCS), previously the Soil Conservation Service (SCS) survey was also reviewed to evaluate the site. The position of mappable units within the subject property are shown on the Geologic Map. Our mapping procedures involved both field reconnaissance and measurements and air photo reconnaissance and interpretation. The same mapping procedures have also been utilized to produce the Geology/Engineering Geology Map which identified pertinent geologic conditions affecting development. The field mapping was performed by personnel of Entech Engineering, Inc. on January 31, 2019.

The site was previously investigated by 285 Engineering as a part of the Onsite Wastewater Treatment System Design prepared for the site (Reference 1). The Profile Holes from the 285 Engineering investigation were also used in evaluating the site and are included in Appendix B.

5.0 SOIL, GEOLOGY AND ENGINEERING GEOLOGY

5.1 General Geology

Physiographically, the site lies in the western portion of the Great Plains Physiographic Province south of the Palmer Divide. Approximately 8 miles to the west is a major structural feature known as the Rampart Range Fault. This fault marks the boundary between the Great Plains Physiographic Province and the Southern Rocky Mountain Province. The site exists within the southeastern edge of a large structural feature known as the Denver Basin. Bedrock in the area tends to be very gently dipping in a northwesterly direction (Reference 2). The rocks in the area of the site are sedimentary in nature and typically Tertiary to Upper Cretaceous in age. The bedrock underlying the site consists of the Dawson Arkose Formation. Overlying this formation are unconsolidated deposits of residual soils, sheetwash, and alluvial soils of the Quaternary Age. The residual soils are produced by the in-situ action of weathering of the bedrock on site. The sheetwash and alluvial soils were deposited by water in the drainage in the western portion of the site. The site's stratigraphy will be discussed in more detail in Section 5.3.

5.2 Soil Conservation Survey

The Natural Resource Conservation Service (Reference 3), previously the Soil Conservation Service (Reference 4) has mapped one soil type on the site (Figure 4). In general, the soils consist of sandy loam to loamy sands. The soils are described as follows:

<u>Type</u>	<u>Description</u>
41	Kettle Gravelly Loamy Sands, 8-40% slopes

Complete descriptions of the soil type are presented in Appendix C. The soils have generally been described to typically have rapid permeabilities. Possible hazards with soil erosion are present on the site. The erosion potential can be controlled with vegetation. The majority of the soils have been described to have moderate erosion hazards (Reference 4).

5.3 Site Stratigraphy

The Monument Quadrangle Geology Map showing the site is presented in Figure 5 (Reference 5). The Geology Map prepared for the site is presented in Figure 6. Two mappable units were identified on this site which are described as follows:

Qau Alluvium, undivided of Holocene to Pleistocene Age: These are water and sheetwash deposits, undifferentiated, that have been deposited along the drainage that exists in the extreme western portion of the site. These materials typically consist of silty to clayey sands and sandy clays. Some of these alluviums contain highly organic soils.

Tkd Dawson Formation of Tertiary to Cretaceous Age: The Dawson Formation typically consists of arkosic sandstone with interbedded fine-grained sandstone, siltstone and claystone. Overlying this formation is a variable layer of residual soil. The residual soils were derived from the in-situ weathering of the bedrock materials on-site. These soils consisted of silty to clayey sands and sandy clays.

The soils listed above were mapped from site-specific mapping, the *Geologic Map of the Monument Quadrangle* distributed by the Colorado Geological Survey in 2003 (Figure 5,

Reference 5), the *Geologic Map of the Colorado Springs-Castle Rock Area*, distributed by the US Geological Survey in 1979 (Reference 6), and the *Geologic Map of the Denver 1° x 2° Quadrangle*, distributed by the US Geological Survey in 1981 (Reference 7). The Profile Holes by 285 Engineering (Reference 1) were also used in evaluating the site and are included in Appendix B. The Geology Map prepared for the site is presented in Figure 6.

5.4 Soil Conditions

Ten (10) Profile Holes were excavated by 285 Engineering as a part of the Onsite Wastewater Treatment System Design (Reference 1). The profile holes were excavated to 8 feet in the areas of the proposed systems surrounding the proposed structures. The soils encountered in the profile holes consisted of sandy loam with gravel in five of the profile holes and sandy clay or sandy clay loam in the other five profile holes. Typically the clay and clay loam encountered in the area has expansion potential. The Profile Hole Logs are included in Appendix B.

5.5 Groundwater

Groundwater was not encountered in the profile holes by 285 Engineering which were excavated to 8 feet (Reference 1, Appendix B). Areas of potentially seasonal shallow groundwater have been mapped in a drainage in the extreme western portion of the site. These areas are discussed in the following section. Fluctuation in groundwater conditions may occur due to variations in rainfall and other factors not readily apparent at this time.

It should be noted that in the sandy materials on site, some groundwater conditions might be encountered due to the variability in the soil profile. Isolated sand and gravel layers within the soils, sometimes only a few feet in thickness and width, can carry water in the subsurface. Groundwater may also flow on top of the underlying bedrock. Builders and planners should be cognizant of the potential for the occurrence of such subsurface water features during construction on-site and deal with each individual problem as necessary at the time of construction.

6.0 ENGINEERING GEOLOGY – IDENTIFICATION AND MITIGATION OF GEOLOGIC HAZARDS

As mentioned previously, detailed mapping has been performed on this site to produce an Geology/Engineering Geology Map (Figure 6). This map shows the location of various geologic conditions of which the developers should be cognizant during the planning, design and construction stages of the project. These hazards and the recommended mitigation techniques are as follows:

Expansive Soils

Clay soils were encountered in some of the profile holes excavated on-site by 285 Engineering (Reference 1, Appendix B). These soils commonly have expansion potential. Expansive clay soils and claystone are commonly encountered within the Dawson Formation and the overlying residual soils in the area. These occurrences are typically sporadic; therefore, none have been indicated on the maps. Expansive soils, if encountered beneath foundations, can cause differential movement in the structure foundation. These occurrences should be identified and mitigated on an individual lot basis.

Mitigation: Should expansive soils be encountered beneath the foundation, mitigation will be necessary. Mitigation of expansive soils will require special foundation design. Overexcavation and replacement with non-expansive soils at a minimum of 95% of its maximum Modified Proctor Dry Density, ASTM D-1557 is a suitable mitigation, which is common in the area. Another alternative in areas of highly expansive soils is the use of drilled pier foundation systems. Typical minimum pier depths are on the order of 25 feet or more and require penetration into the bedrock material a minimum of 4 to 6 feet, depending upon building loads. Floor slabs on expansive soils should be expected to experience movement. Overexcavation and replacement has been successful in minimizing slab movements. The use of structural floors should be considered for basement construction on highly expansive clays. Final recommendations should be determined after additional investigation of each building site.

Drainage Areas: Potential Seasonal Shallow Groundwater Area and Floodplains

The site is not mapped within any floodplains according to the FEMA Map No. 08041CO295F, (Figure 7, Reference 8). Areas of potentially seasonal shallow groundwater were observed in

the drainage in the extreme western portion of the site. In these areas, we would anticipate the potential for periodically high subsurface moisture conditions and frost heave potential. These areas lie in the extreme western portion of the site well away from the proposed development and can likely be avoided or properly mitigated by development. Additionally, minor swales exist in the rolling topography of the site in the building areas. The potential exists for high groundwater levels during high moisture periods in the drainage area or may be encountered in low swale areas. Should structures encroach on these areas or other low-lying areas of the site, the following precautions should be followed.

Mitigation: Foundations must have a minimum 30-inch depth for frost protection. In areas where high subsurface moisture conditions are anticipated periodically, subsurface perimeter drains are recommended to help prevent the intrusion of water into areas below grade. Typical drain details are presented in Figure 8. Much of the minor swale topography in the building areas can be mitigated by site grading. Structures should not block drainages. Any grading on the site should be done to direct surface flow around construction to avoid areas of ponded water near structures or septic fields. All organic material would be completely removed prior to any fill placement. Specific drainage studies are beyond the scope of this report.

Potential Unstable Slope

A steep road cut along Benet Lane in the north-central portion of the site has been identified as potentially unstable. The road cut is not excessively high and is cut in sandstone bedrock. Exposed Dawson Sandstone with an overlying layer of residual soils was observed in the road cut and it appears to be relatively stable in its present condition. Care should be taken that unstable conditions are not created by development. Structures are proposed near this road cut that may require mitigation.

Mitigation: Foundations immediately adjacent to the road cut will require stepping down to avoid adding surcharges to the road cut. Additional reinforcement, such as tie beams or buttresses, may also be required. Surface stabilization of the soils to prevent erosion may also be necessary, depending on the location from the proposed structures. Another option is to stabilize the slope. Stabilization could involve regrading the slope to no steeper than 2:1 or the use of engineer-designed retaining wall. Specific recommendations should be made after additional investigation and when grading plans are finalized.

6.1 Relevance of Geologic Conditions to Land Use Planning

As mentioned earlier in this report, we understand that the development will be residential. It is our opinion that the existing geologic and engineering geologic conditions will impose some minor constraints on the proposed development and construction. The hazards on this site include minor areas of potentially seasonal shallow groundwater, the potential for expansive soils, and a potentially unstable slope associated with a road cut. The hazards on site may be satisfactorily mitigated through avoidance or proper engineering design and construction practices.

The soils encountered in the profile holes by 285 Engineering consisted of sandy loam with gravel and sandy clay. The granular soils encountered in the profile holes should provide good support for foundations. Clays, although sporadic, were encountered on the site. Expansive clay soils, clayey sandstone and claystone are common in the Dawson Formation, and may require mitigation. These soils will not prohibit development. Foundations anticipated for the site are standard spread footings possibly in conjunction with overexcavation in areas of expansive soils or loose soils. Areas containing arkosic sandstone will have high allowable bearing conditions. Difficult excavation should be anticipated in areas of shallow bedrock. Expansive layers may also be encountered in the soil and bedrock on this site. Areas of expansive soils encountered on site are sporadic; therefore, none have been indicated on the maps.

Provide an exhibit in this report that shows the unstable areas and how to mitigate for them.

A potentially unstable slope has been mapped in the north-central portion of the site associated with a road cut along Benet Lane. A structure is proposed adjacent to the road cut. Sandstone was observed exposed in the road cut. It is recommended the foundation for structures that encroach on the road cut should be stepped down to prevent added surcharges to the slope. Additional reinforcement may also be required, such as tie beams or buttresses. Other alternatives include the use of drilled pier foundation systems or stabilizing the slope. Stabilization could involve regrading the slope to no steeper than 2:1 or the use of engineer-designed retaining walls.

Areas of potentially seasonal shallow groundwater were encountered on site. These areas are associated with a drainage area located in the extreme western portion of the site. Based on

the proposed development plan, these areas will be avoided by construction. Structures should not block drainages. Any site grading should be done to direct surface drainage around structures and away from septic field. Septic fields should not be located in drainage areas due to the potential for periodic high groundwater conditions.

In summary, development of the site can be achieved if the items mentioned above are mitigated. These items can be mitigated through proper design and construction or through avoidance. Additional site-specific investigation is recommended prior to construction.

7.0 ECONOMIC MINERAL RESOURCES

Some of the sandy materials on-site could be considered a low-grade sand resource. According to the *El Paso County Aggregate Resource Evaluation Map* (Reference 9), the area of the site is not mapped with any resources. According to the *Atlas of Sand, Gravel and Quarry Aggregate Resources, Colorado Front Range Counties* distributed by the Colorado Geological Survey (Reference 10), areas of the site are not mapped with any resources. According to the *Evaluation of Mineral and Mineral Fuel Potential* (Reference 11), the area of the site has been mapped as "Good" for industrial minerals. However, considering the silty to clayey nature of much of these materials and abundance of similar materials through the region and the close proximity to developed land, they would be considered to have little significance as an economic resource.

According to the *Evaluation of Mineral and Mineral Fuel Potential of El Paso County State Mineral Lands* (Reference 11), the site is mapped within the Denver Basin Coal Region. However, the area of the site has been mapped as "Poor" for coal resources. No active or inactive mines have been mapped in the area of the site. No metallic mineral resources have been mapped on the site (Reference 11).

The site has been mapped as "Fair" for oil and gas resources (Reference 11). No oil or gas fields have been discovered in the area of the site. The sedimentary rocks in the area may lack the geologic structure for trapping oil or gas; therefore, it may not be considered a significant resource. Hydraulic fracturing is a new method that is being used to extract oil and gas from rocks. It utilizes pressurized fluid to extract oil and gas from rocks that would not normally be

productive. The area of the site has not been explored to determine if the rocks underlying the site would be commercially viable utilizing hydraulic fracturing. The practice of hydraulic fracturing has come under review due to concerns about environmental impacts, health and safety.

8.0 EROSION CONTROL

The soil types observed on the site are mildly to highly susceptible to wind erosion, and moderately to highly susceptible to water erosion. A minor wind erosion and dust problem may be created for a short time during and immediately after construction. Should the problem be considered severe enough during this time, watering of the cut areas or the use of chemical palliative may be required to control dust. However, once construction has been completed and vegetation re-established, the potential for wind erosion should be considerably reduced.

With regard to water erosion, loosely compacted soils will be the most susceptible to water erosion, residually weathered soils and weathered bedrock materials become increasingly less susceptible to water erosion. For the typical soils observed on site, allowable velocities or unvegetated and unlined earth channels would be on the order of 3 to 4 feet/second, depending upon the sediment load carried by the water. Permissible velocities may be increased through the use of vegetation to something on the order of 4 to 7 feet/second, depending upon the type of vegetation established. Should the anticipated velocities exceed these values, some form of channel lining material may be required to reduce erosion potential. These might consist of some of the synthetic channel lining materials on the market or conventional riprap. In cases where ditch-lining materials are still insufficient to control erosion, small check dams or sediment traps may be required. The check dams will serve to reduce flow velocities, as well as provide small traps for containing sediment. The determination of the amount, location and placement of ditch linings, check dams and of the special erosion control features should be performed by or in conjunction with the drainage engineer who is more familiar with the flow quantities and velocities.

Cut and fill slope areas will be subjected primarily to sheetwash and rill erosion. Unchecked rill erosion can eventually lead to concentrated flows of water and gully erosion. The best means to combat this type of erosion is, where possible, the adequate re-vegetation of cut and fill

slopes. Cut and fill slopes having gradients more than three (3) horizontal to one (1) vertical become increasingly more difficult to revegetate successfully. Therefore, recommendations pertaining to the vegetation of the cut and fill slopes may require input from a qualified landscape architect and/or the Soil Conservation Service.

9.0 CLOSURE

It is our opinion that the existing geologic engineering and geologic conditions will impose some minor constraints on development and construction of the site. The majority of these conditions can be avoided by construction. Others can be mitigated through proper engineering design and construction practices. The proposed development and use are consistent with anticipated geologic and engineering geologic conditions.

It should be pointed out that because of the nature of data obtained by random sampling of such variable and non-homogeneous materials as soil and rock, it is important that we be informed of any differences observed between surface and subsurface conditions encountered in construction and those assumed in the body of this report. Individual investigations for building sites and septic systems will be required prior to construction. Construction and design personnel should be made familiar with the contents of this report. Reporting such discrepancies to Entech Engineering, Inc. soon after they are discovered would be greatly appreciated and could possibly help avoid construction and development problems.

This report has been prepared for MVE, Inc., for application to the proposed project in accordance with generally accepted geologic soil and engineering practices. No other warranty expressed or implied is made.

We trust that this report has provided you with all the information that you required. Should you require additional information, please do not hesitate to contact Entech Engineering, Inc.

BIBLIOGRAPHY

1. 285 Engineering. June 18, 2018. *Onsite Wastewater Treatment System Design, 3190 Benet Lane, Colorado Springs, Colorado*. Project No. 2018196
2. Bryant, Bruce; McGrew, Laura W, and Wobus, Reinhard A. 1981. *Geologic Structure Map of the Denver 1° x 2° Quadrangle, North-Central Colorado*. Sheet 2. U.S. Geologic Survey. Map I-1163
3. Natural Resource Conservation Service, September 23, 2016. *Web Soil Survey*. United States Department Agriculture, <http://websoilsurvey.sc.egov.usda.gov/App/HomePage.htm>.
4. United States Department of Agriculture Soil Conservation Service. June 1981. *Soil Survey of El Paso County Area, Colorado*.
5. Thorson, Jon P. and Madole, Richard F., 2003. *Geologic Map of the Monument Quadrangle, El Paso County, Colorado*. Colorado Geological Survey. Open-File Report 02-40.
6. Trimble, Donald E. and Machette, Michael N. 1979. *Geologic Map of the Colorado Springs-Castle Rock Area, Front Range Urban Corridor, Colorado*. USGS, Map I-857-F.
7. Bryant, Bruce; McGrew, Laura W. and Wobus, Reinhard A. 1981. *Geologic Map of the Denver 1° x 2° Quadrangle, North-Central Colorado*. U.S. Geologic Survey. Map 1-1163.
8. Federal Emergency Management Agency. March 17, 1997. *Flood Insurance Rate Maps for the City of Colorado Springs, Colorado*. Map Number 08041CO295F
9. El Paso County Planning Development. December 1995. *El Paso County Aggregate Resource Evaluation Maps*.
10. Schwochow, S.D.; Shroba, R.R. and Wicklein, P.C. 1974. *Atlas of Sand, Gravel, and Quarry Aggregate Resources, Colorado Front Range Counties*. Colorado Geological Survey. Special Publication 5-B.
11. Keller, John W.; TerBest, Harry and Garrison, Rachel E. 2003. *Evaluation of Mineral and Mineral Fuel Potential of El Paso County State Mineral Lands Administered by the Colorado State Land Board*. Colorado Geological Survey. Open-File Report 03-07.

FIGURES

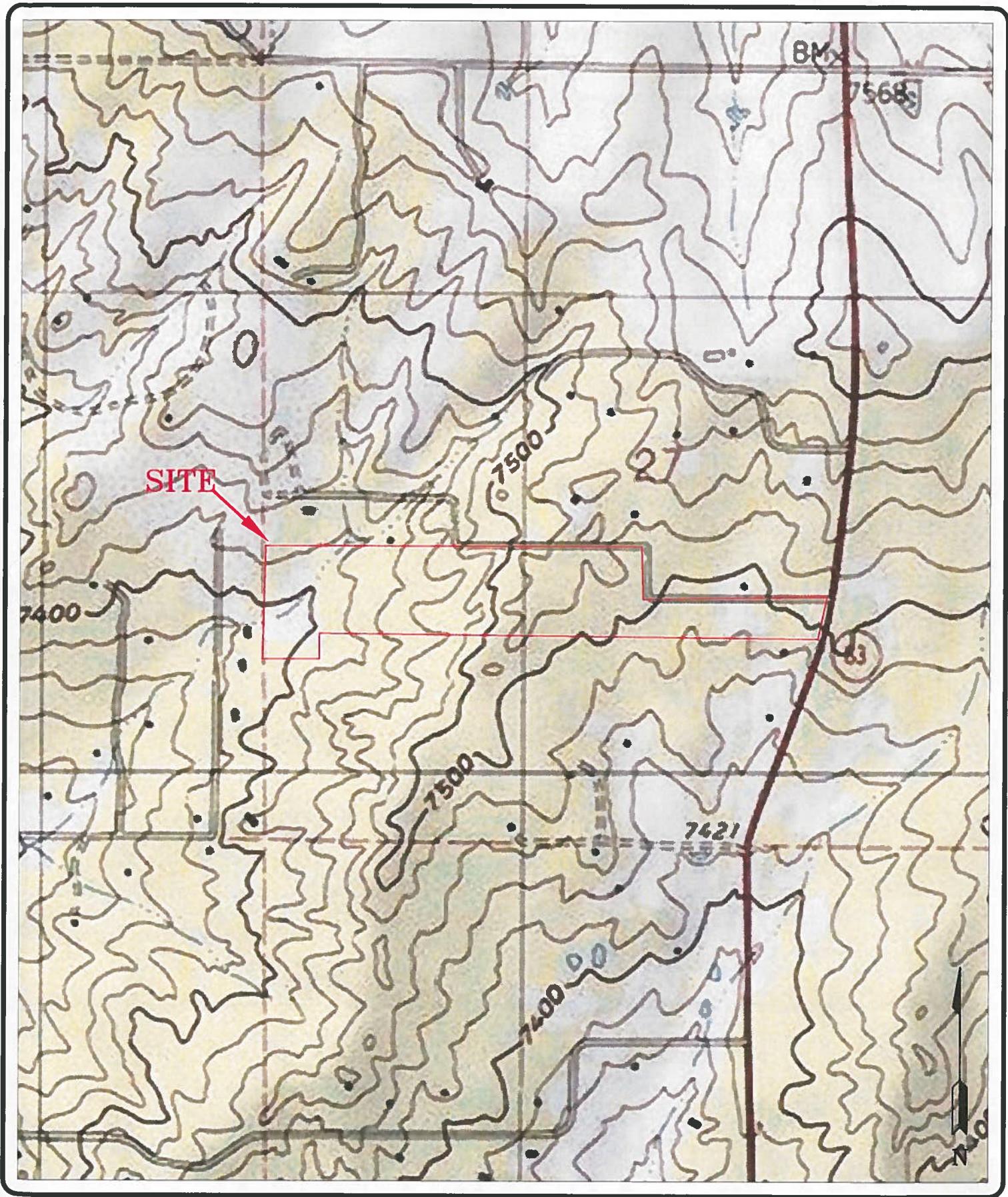

ENTECH
ENGINEERING, INC.

505 ELKTON DRIVE
COLORADO SPRINGS, CO. 80907 (719) 531-5599

USGS MAP
SANCTUARY OF PEACE FILING NO. 1
BENET LANE AND HIGHWAY 83
EL PASO COUNTY, CO.
FOR: MVE, INC.

DRAWN:
KAH

DATE:
1/30/19

CHECKED:

DATE:

JOB NO.:
190118

FIG NO.:
2

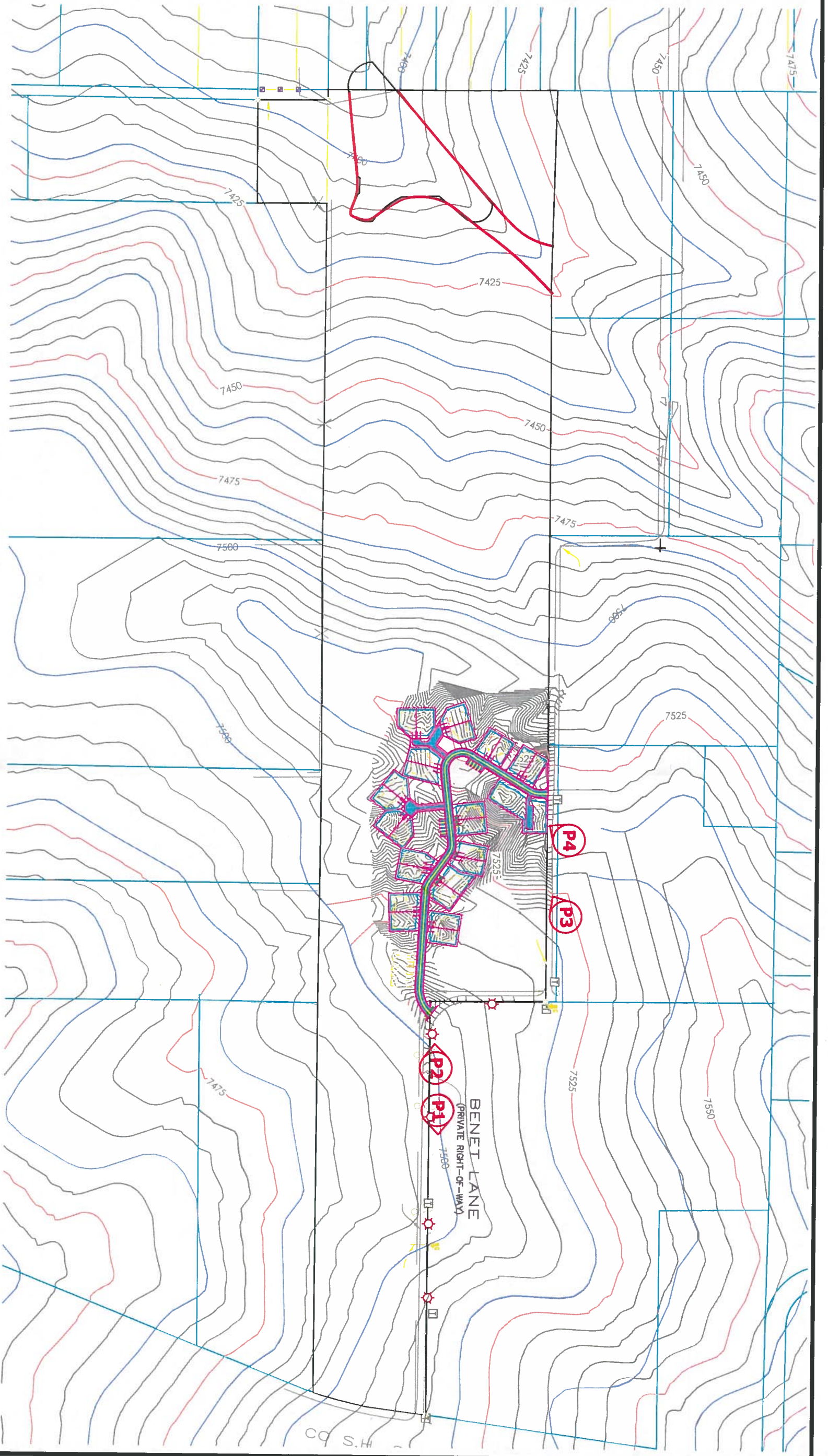

P2 - APPROXIMATE TEST PIT LOCATION AND NUMBER



DATE	2/8/10
BY	AS SHOWN
SCALE	1"=40'
PROJECT	100118
FILE NO.	100118
3	

SITE PLAN
SANCTUARY OF PEACE FILING NO. 1
BENET LANE AND HIGHWAY 83
EL PASO COUNTY, CO.
FOR: MVE, INC.



ENTECH
ENGINEERING, INC.
 505 ELKTON DRIVE
 COLORADO SPRINGS, CO. 80907 (719) 531-5599

REVISION	BY

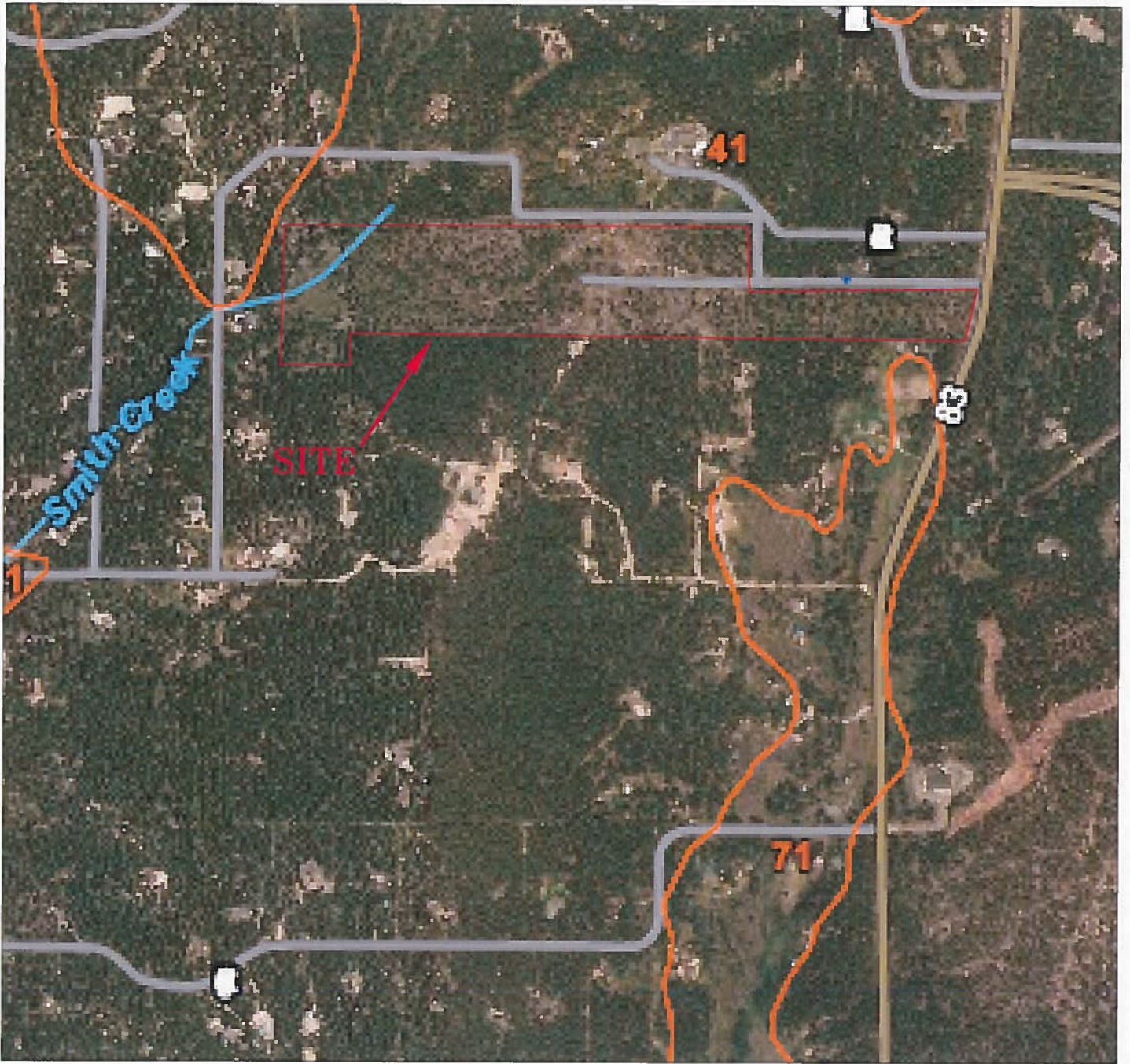

ENTECH
ENGINEERING, INC.

505 ELKTON DRIVE
COLORADO SPRINGS, CO. 80907 (719) 531-5599

SOIL SURVEY MAP
SANCTUARY OF PEACE FILING NO. 1
BENET LANE AND HIGHWAY 83
EL PASO COUNTY, CO.
FOR: MVE, INC.

DRAWN:
KAH

DATE:
1/30/19

CHECKED:

DATE:

JOB NO.:
190118

FIG NO.:
4



ENTECH
ENGINEERING, INC.
 505 ELKTON DRIVE
 COLORADO SPRINGS, CO. 80907 (719) 531-5599

MONUMENT QUADRANGLE GEOLOGIC MAP
SANCTUARY OF PEACE FILING NO. 1
BENET LANE AND HIGHWAY 83
EL PASO COUNTY, CO.
FOR: MVE, INC.

DRAWN:
KAH

DATE:
1/30/19

CHECKED:

DATE:

JOB NO.:
190118

FIG NO.:
5

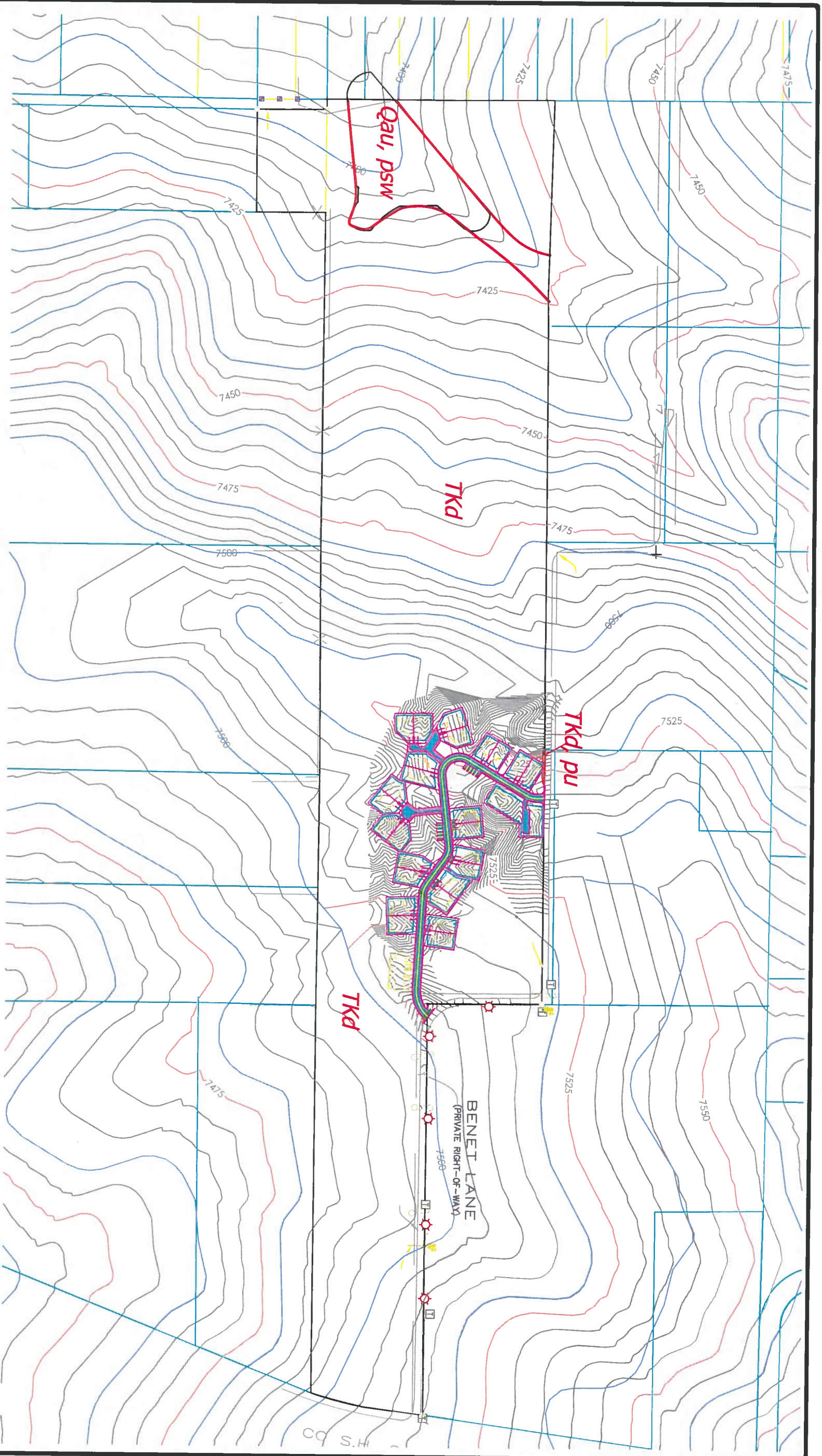

LEGEND:
 Qau - Recent Alluvium of Quaternary Age:
 recent water deposited materials associated with a drainage on the western side of site

TKda - Dawson Formation of Tertiary to Cretaceous Age:
 arkosic sandstone with interbedded fine-grained sandstone, siltstone and claystone

psw - potentially seasonal shallow groundwater
 pu - potentially unstable slope



DATE	2/8/19
SCALE	AS SHOWN
BY	AS SHOWN
DATE	190118
FIGURE NO.	6

GEOLOGY/ENGINEERING GEOLOGY MAP
SANCTUARY OF PEACE FILING NO. 1
BENET LANE AND HIGHWAY 83
EL PASO COUNTY, CO.
FOR: MVE, INC.



ENTECH
ENGINEERING, INC.
 505 ELKTON DRIVE
 COLORADO SPRINGS, CO. 80907 (719) 531-5599

REVISION BY	

LEGEND

SPECIAL FLOOD HAZARD AREAS SUBJECT TO INUNDATION BY THE 1% ANNUAL CHANCE FLOOD

The 1% annual chance flood (100-year flood), also known as the base flood, is the flood that has a 1% chance of being equaled or exceeded in any given year. The Special Flood Hazard Area is the area subject to flooding by the 1% annual chance flood. Areas of Special Flood Hazard include Zones A, AE, AH, AO, A99, V, VE, X, and Y. The Base Flood Elevation is the water-surface elevation of the 1% annual chance flood.

ZONE A No Base Flood Elevations determined.

ZONE AE Base Flood Elevations determined.

ZONE AH Flood depths of 1 to 3 feet (usually areas of ponding). Base Flood Elevations determined.

ZONE AO Flood depths of 1 to 3 feet (usually sheet flow on sloping terrain); average depths determined. For areas of alluvial fan flooding, velocities also determined.

ZONE A99 Special Flood Hazard Area formerly protected from the 1% annual chance flood by a flood control system that was subsequently decertified. Zone A99 indicates that the former flood control system is being restored to provide protection from the 1% annual chance or greater flood.

ZONE V Area to be protected from 1% annual chance flood by a Federal flood protection system under construction; no Base Flood Elevations determined.

ZONE VE Coastal flood zone with velocity hazard (wave action); no Base Flood Elevations determined.

FLOODWAY AREAS IN ZONE AE

The floodway is the channel of a stream plus any adjacent floodplain areas that must be kept free of encroachment so that the 1% annual chance flood can be carried without substantial increases in flood heights.

OTHER FLOOD AREAS

Areas of 0.2% annual chance flood; areas of 1% annual chance flood with average depths of less than 1 foot or with drainage areas less than 1 square mile; and areas protected by levees from 1% annual chance flood.

OTHER AREAS

Areas determined to be outside the 0.2% annual chance floodplain.

ZONE D Areas in which flood hazards are undetermined, but possible.

COASTAL BARRIER RESOURCES SYSTEM (CBRS) AREAS

OTHERWISE PROTECTED AREAS (OPAs)

CBRS areas and OPAs are normally located within or adjacent to Special Flood Hazard Areas

1% annual chance floodplain boundary

0.2% annual chance floodplain boundary

Floodway boundary

Zone D boundary

CBRS and OPA boundary

Boundary dividing Special Flood Hazard Area Zones and boundary dividing Special Flood Hazard Areas of different Base Flood Elevations, flood depths or flood velocities.

Base Flood Elevation line and value; elevation in feet* (L.L. 5107)

Base Flood Elevation value where uniform within area; elevation in feet*

Referenced to the National Geodetic Vertical Datum of 1929

From section line

Transect line

Geographic coordinates referenced to the North American Datum of 1983 (NAD 83), Western Hemisphere

1000-meter Universal Transverse Mercator grid tick values, zone 4

5000-foot grid tick values; Hawaii State Plane coordinate system, zone 3 (FIPS ZONE 5103), Transverse Mercator projection

Bench mark (see explanation in Notes to Users section of this FIRM panel)

Coastal mile marker

MAP REPOSITORY

Refer to listing of Map Repositories on Map Index

EFFECTIVE DATE OF COUNTYWIDE FLOOD INSURANCE RATE MAP

November 20, 2000

EFFECTIVE DATES OF REVISIONS TO THIS PANEL

September 30, 2004 - to change Special Flood Hazard Areas, to update map format, to reflect revised shoreline and to incorporate previously issued Letters of Map Revision.

**LOCATED WITHIN
TOWNSHIP 12 SOUTH,
RANGE 65 WEST**

PARK AVENUE

MIDDLE ROAD

POOLS GOLD LAKE

BENET LAKE

27

23

SITE

**EL PASO COUNTY
UNINCORPORATED AREAS
080059**

STATIONBUSH ROAD

34

Please use the latest Flood Plain Map/Panel. These maps were updated effective December 7 2018.

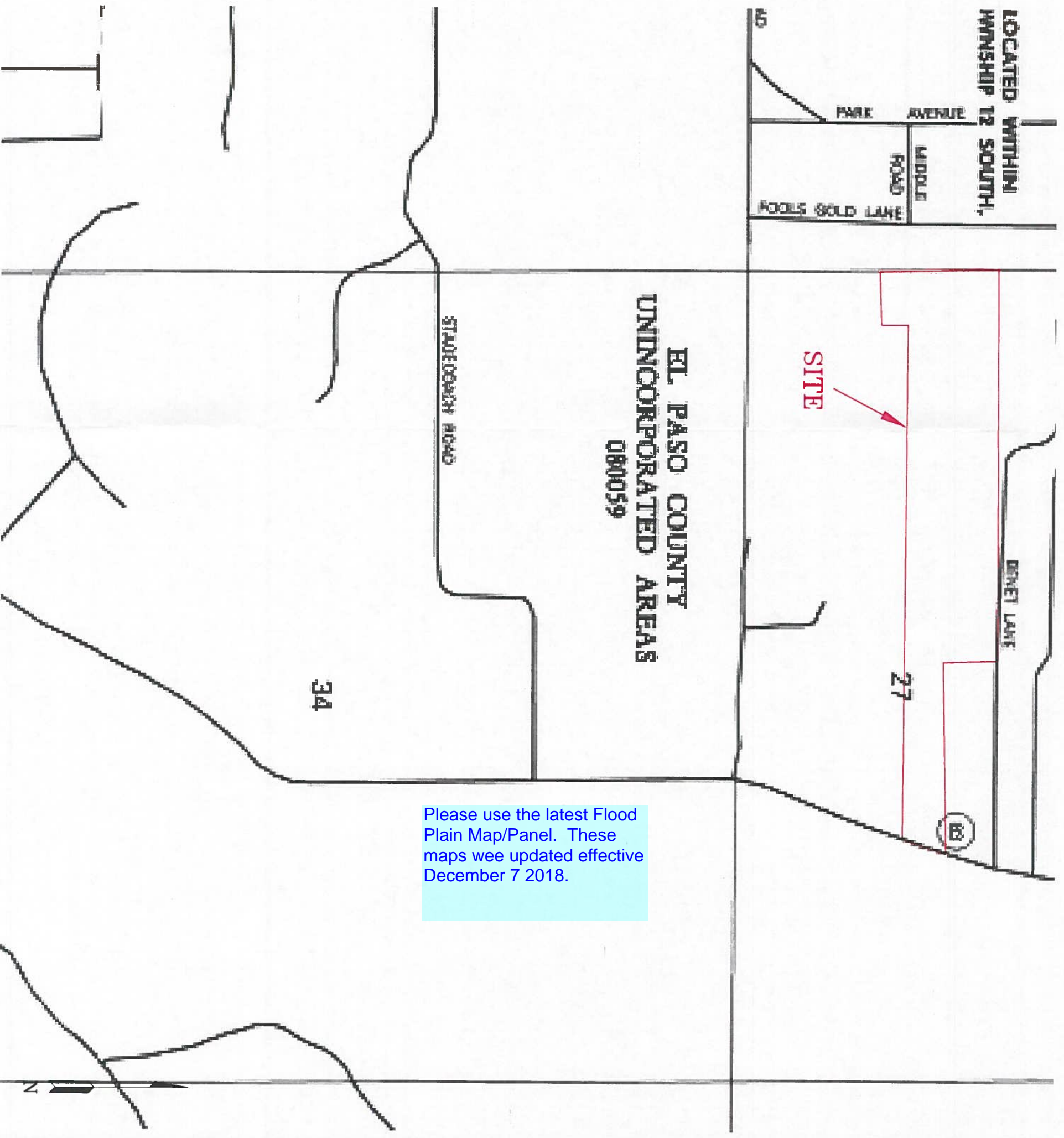

**ENTECH
ENGINEERING, INC.**
505 ELKTON DRIVE
COLORADO SPRINGS, CO. 80907 (719) 531-5599

**FLOODPLAIN MAP
SANCTUARY OF PEACE FILING NO. 1
BENET LAKE AND HIGHWAY 83
EL PASO COUNTY, CO.
FOR: MVE, INC.**

DATE	2/5/19
CHECKED	AS SHOWN
DRAWN	JOB NO. 190118
KAM	FIGURE NO. 7

REVISION	BY

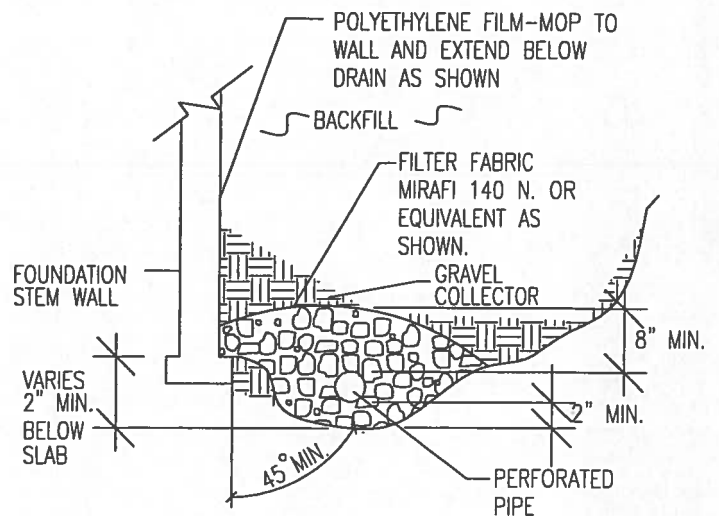
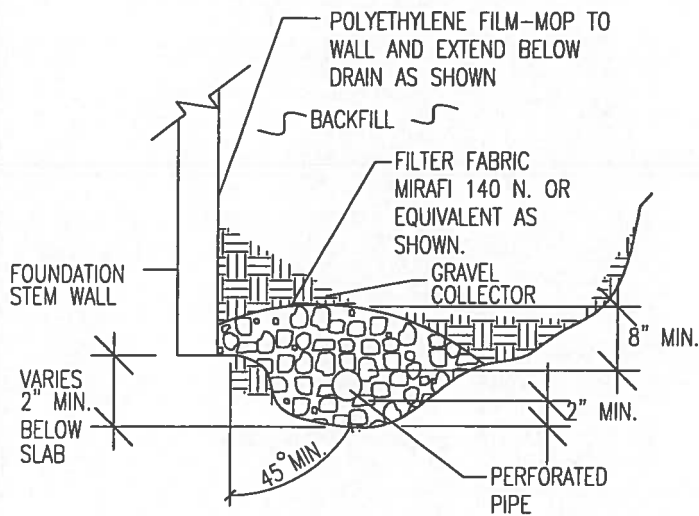

NOTES:

-GRAVEL SIZE IS RELATED TO DIAMETER OF PIPE PERFORATIONS-85% GRAVEL GREATER THAN 2x PERFORATION DIAMETER.

-PIPE DIAMETER DEPENDS UPON EXPECTED SEEPAGE. 4-INCH DIAMETER IS MOST OFTEN USED.

-ALL PIPE SHALL BE PERFORATED PLASTIC. THE DISCHARGE PORTION OF THE PIPE SHOULD BE NON-PERFORATED PIPE.

-FLEXIBLE PIPE MAY BE USED UP TO 8 FEET IN DEPTH, IF SUCH PIPE IS DESIGNED TO WITHSTAND THE PRESSURES. RIGID PLASTIC PIPE WOULD OTHERWISE BE REQUIRED.

-MINIMUM GRADE FOR DRAIN PIPE TO BE 1% OR 3 INCHES OF FALL IN 25 FEET.

-DRAIN TO BE PROVIDED WITH A FREE GRAVITY OUTFALL, IF POSSIBLE. A SUMP AND PUMP MAY BE USED IF GRAVITY OUT FALL IS NOT AVAILABLE.



ENTECH
ENGINEERING, INC.
505 ELKTON DRIVE
COLORADO SPRINGS, CO. 80907 (719) 531-5599

PERIMETER DRAIN DETAIL

DRAWN:

DATE:

2/8/19

DESIGNED:

DS

CHECKED:

u

JOB NO.:

190118

FIG NO.:

8

APPENDIX A: Site Photographs

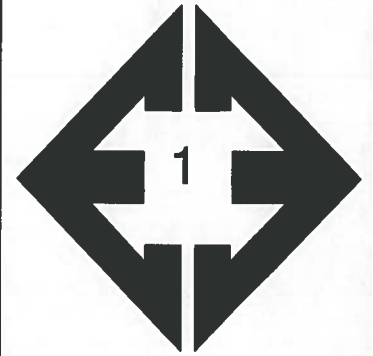

**Looking east along
main road eastern side
of site.**

January 31, 2019

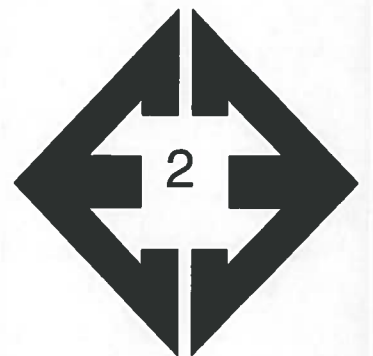

**Looking west from the
eastern side of the
site.**

January 31, 2019

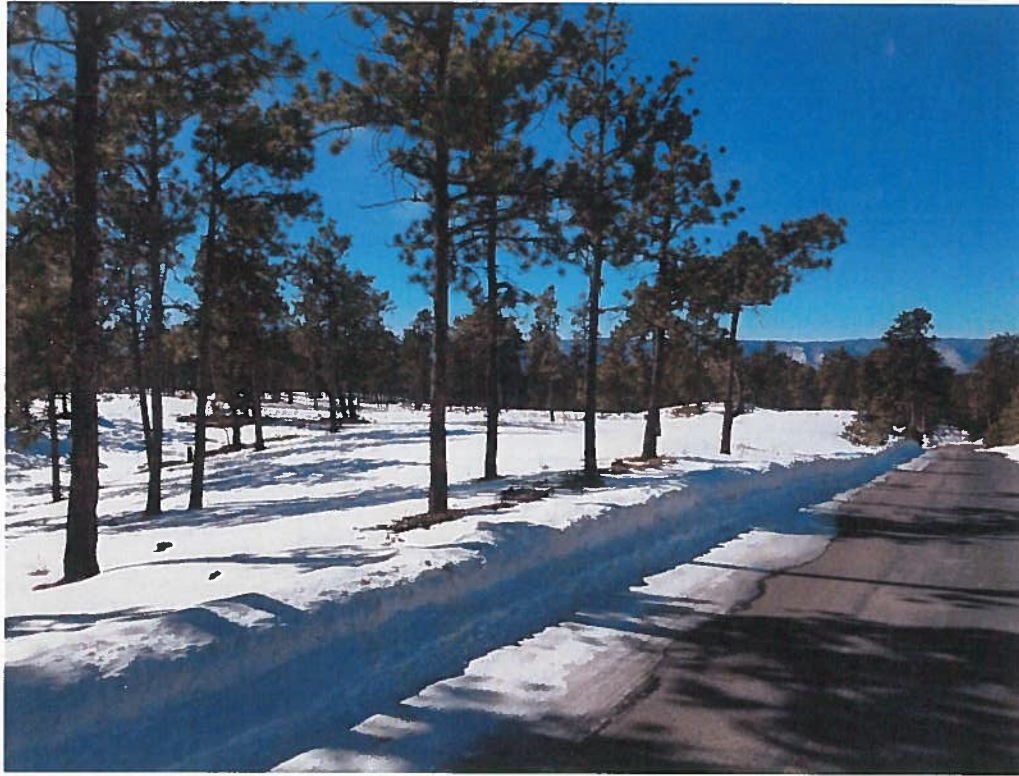

**Looking southwest
from the northern side
of the site.**

January 31, 2019



**Looking southwest at
road cut in northern
portion of the site.**

January 31, 2019

APPENDIX B: Profile Holes from 285 Engineering

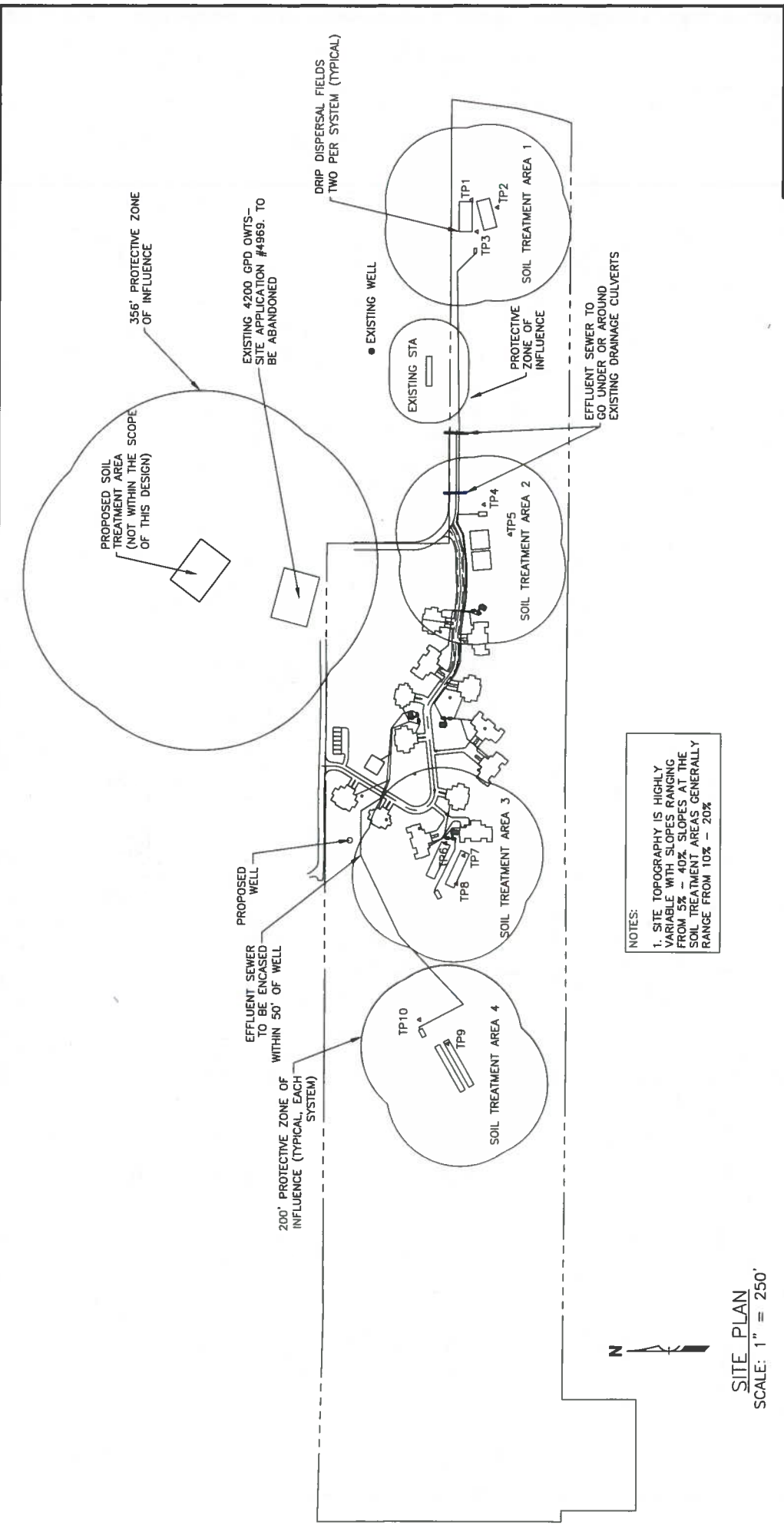

NOTES:
 1. SITE TOPOGRAPHY IS HIGHLY VARIABLE WITH SLOPES RANGING FROM 5% - 40%. SLOPES AT THE SOIL TREATMENT AREAS GENERALLY RANGE FROM 10% - 20%



SITE PLAN
 SCALE: 1" = 250'

PROJECT: 2018196 LOCATION: 3190 BENET LANE COLORADO SPRINGS, CO 80921 CLIENT: BENET HILL MONASTERY	TITLE: PROJECT SITE PLAN		SHEET: 2/15
	DATE: 06/18/2018	REVISIONS: 	
SCALE: SHOWN			

285 ENGINEERING
 P.O. BOX 1048
 CONIFER, CO
 80433
 (720)-515-1781

SOILS INFORMATION

DATE TESTING COMPLETED: 06/19/2018
 EQUIPMENT USED: EXCAVATOR NOT PRESENT
 DEPTH TO STANDING WATER: NOT PRESENT
 REDOXIMORPHIC FEATURES: NOT PRESENT

SITE EVALUATOR

ROGER J. SHAFER, P.E.
 P.O. BOX 1048
 CONIFER, CO. 80433
 rshafere@285engineering.com
 BS Civil Engineering
 NS Environmental Engineering and Science
 Credentials: CPOW Soils Characterization Class 2012

DIFFICULTIES ENCOUNTERED DURING SITE VISIT

There were no difficulties encountered during the site visit that prevented a complete evaluation of the property.

POTENTIAL LAND USE CHANGES

There are no known or foreseeable use changes that would affect system performance.

ANTICIPATED CONSTRUCTION RELATED ISSUES

No construction related issues are expected for this site.

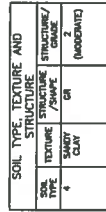
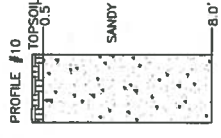
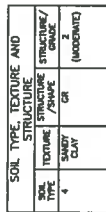
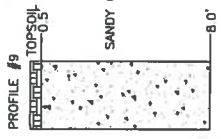
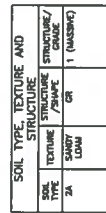
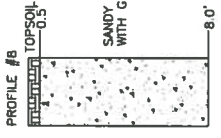
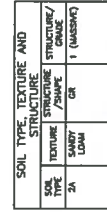
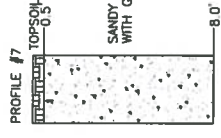
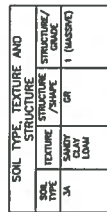
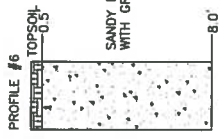
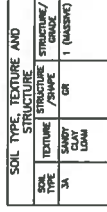
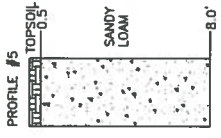
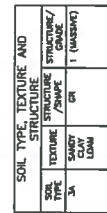
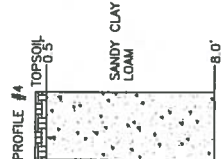
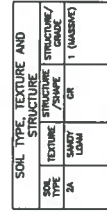
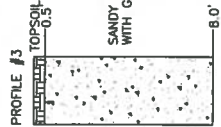
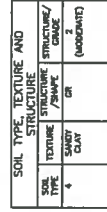
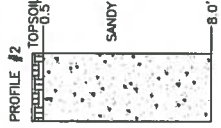
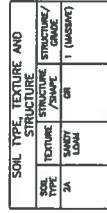
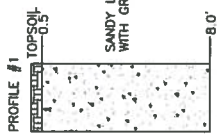

SCALE: 3/16" = 1'



285 ENGINEERING
 P.O. BOX 1048
 CONIFER, CO
 80433
 (720)-515-1781

PROJECT: 2018196
 LOCATION:
 3190 BENET LANE
 COLORADO SPRINGS, CO 80921
 CLIENT: BENET HILL MONASTERY

TITLE: SUBSURFACE CONDITIONS
 DATE: 06/18/2018
 REVISIONS:
 SCALE: SHOWN

SHEET:
 3/15

APPENDIX C: Soil Survey Descriptions

El Paso County Area, Colorado

41—Kettle gravelly loamy sand, 8 to 40 percent slopes

Map Unit Setting

National map unit symbol: 368h
Elevation: 7,000 to 7,700 feet
Farmland classification: Not prime farmland

Map Unit Composition

Kettle and similar soils: 85 percent
Estimates are based on observations, descriptions, and transects of the mapunit.

Description of Kettle

Setting

Landform: Hills
Landform position (three-dimensional): Side slope
Down-slope shape: Linear
Across-slope shape: Linear
Parent material: Sandy alluvium derived from arkose

Typical profile

E - 0 to 16 inches: gravelly loamy sand
Bt - 16 to 40 inches: gravelly sandy loam
C - 40 to 60 inches: extremely gravelly loamy sand

Properties and qualities

Slope: 8 to 40 percent
Depth to restrictive feature: More than 80 inches
Natural drainage class: Somewhat excessively drained
Runoff class: Medium
Capacity of the most limiting layer to transmit water (Ksat): High (2.00 to 6.00 in/hr)
Depth to water table: More than 80 inches
Frequency of flooding: None
Frequency of ponding: None
Available water storage in profile: Low (about 3.4 inches)

Interpretive groups

Land capability classification (irrigated): None specified
Land capability classification (nonirrigated): 7e
Hydrologic Soil Group: B
Hydric soil rating: No

Minor Components

Other soils

Percent of map unit:
Hydric soil rating: No

Pleasant

Percent of map unit:

Landform: Depressions

Hydric soil rating: Yes

Data Source Information

Soil Survey Area: El Paso County Area, Colorado

Survey Area Data: Version 16, Sep 10, 2018

