

PAINT BRUSH HILLS FILING NO. 14
 A REPLAT OF TRACT E, PAINT BRUSH HILLS FILING 13E, BEING A PORTION
 OF THE NE 1/4 SECTION 26, TOWNSHIP 12 SOUTH, RANGE 65 WEST OF
 THE SIXTH PRINCIPAL MERIDIAN, EL PASO COUNTY, COLORADO

BE IT KNOWN BY THESE PRESENTS:

THAT AEROPLAZA FOUNTAIN LLC, A COLORADO LIMITED LIABILITY COMPANY, AND HEIDI LLC, A COLORADO LIMITED LIABILITY COMPANY, BEING THE OWNERS OF THE FOLLOWING DESCRIBED TRACT OF LAND TO WIT:

LEGAL DESCRIPTION:

A PARCEL OF LAND IN THE NORTHEAST QUARTER (NE 1/4) OF SECTION 26, T12S, R65W OF THE 6TH P. M., EL PASO COUNTY, COLORADO, SAID PARCEL BEING TRACT E, "PAINT BRUSH HILLS FILING NO. 13E", RECORDED UNDER RECEPTION NO. 219714420 IN THE RECORDS OF EL PASO COUNTY, COLORADO, BEING MORE PARTICULARLY DESCRIBED AS FOLLOWS:

BEGINNING AT THE QUARTER CORNER COMMON TO SECTIONS 23 AND 26, T12S, R65W OF THE 6TH P. M.; THENCE N88°44'51"E ALONG THE SOUTH LINE OF "PAINT BRUSH HILLS FILING NO. 3" RECORDED IN PLAT BOOK U-3 AT PAGE 79 OF THE EL PASO COUNTY RECORDS 2289.18 FEET;
 THENCE S00°23'09"E ALONG THE WEST LINE OF TRACT A "PAINT BRUSH HILLS FILING NO. 13E" A DISTANCE OF 847.61 FEET;
 THENCE ALONG THE NORTHERLY LINES OF LOTS 117 THROUGH 120, "PAINT BRUSH HILLS FILING NO. 13E" THE FOLLOWING FIVE (5) COURSES;

- (1) THENCE N60°39'45"W A DISTANCE OF 136.44 FEET;
- (2) THENCE N75°42'34"W A DISTANCE OF 136.62 FEET;
- (3) THENCE S82°53'35"W A DISTANCE OF 58.52 FEET;
- (4) THENCE S74°48'58"W A DISTANCE OF 68.80 FEET;
- (5) THENCE S25°20'15"W A DISTANCE OF 45.28 FEET TO THE RIGHT-OF-WAY LINE OF DEVENCORVE DRIVE AS PLATTED ON "PAINT BRUSH HILLS FILING NO. 13E";

THENCE ALONG SAID RIGHT-OF-WAY LINE THE FOLLOWING THREE (3) COURSES:

- (1) THENCE N64°40'00"W A DISTANCE OF 56.87 FEET;
- (2) THENCE S25°20'00"W A DISTANCE OF 50.00 FEET;
- (3) THENCE S64°40'00"E A DISTANCE OF 16.86 FEET TO THE WEST RIGHT-OF-WAY LINE OF KEATING DRIVE AS PLATTED ON "PAINT BRUSH HILLS FILING NO. 13E";

THENCE ALONG SAID WEST RIGHT-OF-WAY LINE THE FOLLOWING FIVE (5) COURSES:

- (1) THENCE S25°20'15"W A DISTANCE OF 823.72 FEET TO A POINT OF CURVE;
- (2) THENCE 264.76 FEET ALONG THE ARC OF A CURVE TO THE RIGHT, SAID CURVE HAVING A RADIUS OF 470.00 FEET, A CENTRAL ANGLE OF 32°16'34", THE CHORD OF 261.28 FEET BEARS S41°28'32"W TO A POINT OF REVERSE CURVE;
- (3) THENCE 430.28 FEET ON THE ARC OF A CURVE TO THE LEFT, SAID CURVE HAVING A RADIUS OF 861.00 FEET, A CENTRAL ANGLE OF 28°38'00", THE CHORD OF 425.82 FEET BEARS S43°17'49"W TO A POINT OF COMPOUND CURVE;
- (4) THENCE 123.89 FEET ALONG THE ARC OF A CURVE TO THE LEFT, SAID CURVE HAVING A RADIUS OF 530.00 FEET, A CENTRAL ANGLE OF 13°23'34", THE CHORD OF 123.60 FEET BEARS S22°17'02"W TO A POINT OF TANGENT;
- (5) THENCE S15°35'15"W A DISTANCE OF 76.75 FEET;

THENCE ALONG THE NORTH LINES OF LOT 2 THROUGH LOT 5 AND ALONG THE NORTH LINE OF TRACT A "PAINT BRUSH HILLS FILING NO. 12" AS RECORDED UNDER RECEPTION NO. 205077511 IN THE EL PASO COUNTY RECORDS THE FOLLOWING SIX (6) COURSES;

- (1) THENCE N74°25'08"W A DISTANCE OF 231.02 FEET;
- (2) THENCE S34°46'45"W A DISTANCE OF 75.34 FEET;
- (3) THENCE S62°22'54"W A DISTANCE OF 141.21 FEET;
- (4) THENCE N80°50'04"W A DISTANCE OF 149.93 FEET;
- (5) THENCE N42°52'08"W A DISTANCE OF 142.64 FEET;
- (6) THENCE S89°26'02"W A DISTANCE OF 299.04 FEET TO THE NORTH-SOUTH CENTERLINE OF SECTION 26;

THENCE N00°34'35"W ALONG SAID NORTH-SOUTH CENTERLINE 2169.63 FEET TO THE POINT OF BEGINNING.

CONTAINING A CALCULATED AREA OF 3,860,479 S. F. (88.624 ACRES MORE OR LESS).

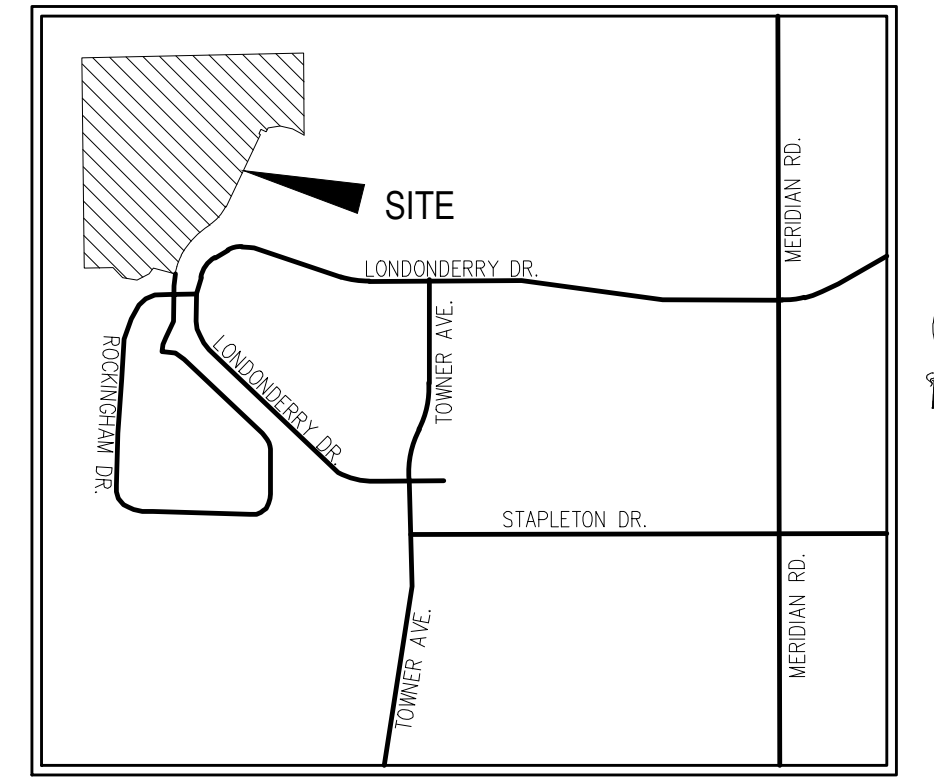

VICINITY MAP
N.T.S.

OWNERS CERTIFICATE/DEDICATION STATEMENT:

THE UNDERSIGNED, BEING ALL THE OWNERS, MORTGAGEES, BENEFICIARIES OF DEEDS OF TRUST AND HOLDERS OF OTHER INTERESTS IN THE LAND DESCRIBED HEREIN, HAVE LAID OUT, SUBDIVIDED, AND PLATTED SAID LANDS INTO LOTS, TRACTS, STREETS, AND EASEMENTS AS SHOWN HEREON UNDER THE NAME AND SUBDIVISION OF "PAINT BRUSH HILLS FILING NO. 14". ALL PUBLIC IMPROVEMENTS SO PLATTED ARE HEREBY DEDICATED TO PUBLIC USE AND SAID OWNER DOES HEREBY COVENANT AND AGREE THAT THE PUBLIC IMPROVEMENTS WILL BE CONSTRUCTED TO EL PASO COUNTY STANDARDS AND THAT PROPER DRAINAGE AND EROSION CONTROL FOR SAME WILL BE PROVIDED AT SAID OWNER'S EXPENSE, ALL TO THE SATISFACTION OF THE BOARD OF COUNTY COMMISSIONERS OF EL PASO COUNTY, COLORADO. UPON ACCEPTANCE BY RESOLUTION, ALL PUBLIC IMPROVEMENTS SO DEDICATED WILL BECOME MATTERS OF MAINTENANCE BY EL PASO COUNTY, COLORADO. THE UTILITY EASEMENTS SHOWN HEREON ARE HEREBY DEDICATED FOR PUBLIC UTILITIES AND COMMUNICATION SYSTEMS AND OTHER PURPOSES AS SHOWN HEREON. THE ENTITIES RESPONSIBLE FOR PROVIDING THE SERVICES FOR WHICH THE EASEMENTS ARE ESTABLISHED ARE HEREBY GRANTED THE PERPETUAL RIGHT OF INGRESS AND EGRESS FROM AND TO ADJACENT PROPERTIES FOR INSTALLATION, MAINTENANCE AND REPLACEMENT OF UTILITY LINES AND RELATED FACILITIES.

THE AFOREMENTIONED AEROPLAZA FOUNTAIN LLC, A COLORADO LIMITED LIABILITY COMPANY, HAS EXECUTED THIS INSTRUMENT THIS _____ DAY OF _____, 2021, A.D.

BY: _____

PRINTED NAME: _____

AS: _____ OF AEROPLAZA FOUNTAIN LLC, A COLORADO LIMITED LIABILITY COMPANY

STATE OF COLORADO)
) SS
COUNTY OF EL PASO)

THE FOREGOING INSTRUMENT WAS ACKNOWLEDGED BEFORE ME THIS THIS _____ DAY OF _____, 2021, A.D. BY _____

AS _____, OF AEROPLAZA FOUNTAIN LLC, A COLORADO LIMITED LIABILITY COMPANY

WITNESS MY HAND AND OFFICIAL SEAL:

MY COMMISSION EXPIRES: _____ NOTARY PUBLIC

THE AFOREMENTIONED HEIDI LLC, A COLORADO LIMITED LIABILITY COMPANY, HAS EXECUTED THIS INSTRUMENT THIS _____ DAY OF _____, 2021, A.D.

BY: _____

PRINTED NAME: _____

AS: _____ OF HEIDI LLC, A COLORADO LIMITED LIABILITY COMPANY

STATE OF COLORADO)
) SS
COUNTY OF EL PASO)

THE FOREGOING INSTRUMENT WAS ACKNOWLEDGED BEFORE ME THIS THIS _____ DAY OF _____, 2021, A.D. BY _____

AS _____, OF HEIDI LLC, A COLORADO LIMITED LIABILITY COMPANY

WITNESS MY HAND AND OFFICIAL SEAL:

MY COMMISSION EXPIRES: _____ NOTARY PUBLIC

TRACT TABLE			
TRACT	SIZE (ACRES)	OWNERSHIP / MAINTENANCE	USE
A	1.314	PBHM	DRAINAGE/PUBLIC IMPROVEMENT/PUBLIC UTILITY/LANDSCAPING/OPEN SPACE/REGIONAL TRAIL EASEMENT
B	0.247	PBHM	DRAINAGE/PUBLIC IMPROVEMENT/PUBLIC UTILITY/LANDSCAPING/OPEN SPACE
TOTAL	1.561		
PBHM = PAINT BRUSH HILLS METRO DISTRICT			

EASEMENTS:

UNLESS SHOWN OTHERWISE, ALL SIDE LOT LINES ARE HEREBY PLATTED WITH A FIVE (5) FEET WIDE PUBLIC UTILITY AND DRAINAGE EASEMENT. REAR LOT LINES ARE HEREBY PLATTED WITH A TEN (10) FEET WIDE PUBLIC UTILITY AND DRAINAGE EASEMENT. ALL FRONT LOT LINES ARE PLATTED WITH A FIVE (5) FEET WIDE PUBLIC UTILITY AND PUBLIC IMPROVEMENT EASEMENT.

AN ADDITIONAL TEN (10) FOOT WIDE EASEMENT FOR PUBLIC UTILITIES, DIRECTLY ADJACENT TO THE FIVE (5) FOOT FRONT LOT LINE EASEMENT REFERRED TO ABOVE.

A TWENTY (20) FOOT WIDE PUBLIC UTILITY AND DRAINAGE EASEMENT ALONG ALL LOTS ADJACENT TO THE SUBDIVISION BOUNDARY, A THIRTY (30) FOOT WIDE PUBLIC UTILITY AND DRAINAGE EASEMENT ALONG THE SUBDIVISION BOUNDARY IS REQUIRED FOR LOTS 7, 8, AND 9.

SIGHT VISIBILITY EASEMENTS AS SHOWN HEREON ARE HEREBY GRANTED TO EL PASO COUNTY. NO IMPROVEMENTS ARE ALLOWED WITHIN THE EASEMENT THAT EXCEED A HEIGHT OF 30 INCHES AS MEASURED ABOVE THE FLOWLINE OF CURB AND GUTTER. SEE DETAILS SHEET 9.

THE SOLE RESPONSIBILITY FOR SURFACE MAINTENANCE OF THESE EASEMENTS IS HEREBY VESTED WITH THE INDIVIDUAL PROPERTY OWNER.

ALL EASEMENTS THAT ARE DEDICATED HEREON FOR PUBLIC UTILITY PURPOSES SHALL BE SUBJECT TO THOSE TERMS AND CONDITIONS AS SPECIFIED IN THE INSTRUMENT RECORDED AT RECEPTION NO. 212112548 OF THE RECORDS OF EL PASO COUNTY, COLORADO. ALL OTHER EASEMENTS OR INTERESTS OF RECORD AFFECTING ANY OF THE PLATTED PROPERTY DEPICTED HEREON SHALL NOT BE AFFECTED AND SHALL REMAIN IN FULL FORCE AND EFFECT.

THE EASEMENTS IDENTIFIED IN THE DETAIL ON SHEET 5 FOR LOTS 3 AND 5 ARE DRAINAGE AND STORM SEWER SYSTEM EASEMENTS. NO DRIVEWAYS OR OTHER PERMANENT STRUCTURE SHALL BE CONSTRUCTED WITHIN THESE EASEMENTS.

SURVEYORS CERTIFICATE

I VERNON P. TAYLOR, A DULY REGISTERED PROFESSIONAL LAND SURVEYOR IN THE STATE OF COLORADO, DO HEREBY CERTIFY THAT THIS PLAT TRULY AND CORRECTLY REPRESENTS THE RESULTS OF A SURVEY MADE ON DATE OF SURVEY, BY ME OR UNDER MY DIRECT SUPERVISION AND THAT ALL MONUMENTS EXIST AS SHOWN HEREON; THAT MATHEMATICAL CLOSURE ERRORS ARE LESS THAN 1:10,000; AND THAT SAID PLAT HAS BEEN PREPARED IN FULL COMPLIANCE WITH ALL APPLICABLE LAWS OF THE STATE OF COLORADO DEALING WITH MONUMENTS, SUBDIVISION, OR SURVEYING OF LAND AND ALL APPLICABLE PROVISIONS OF THE EL PASO COUNTY LAND DEVELOPMENT CODE.

I ATTEST THE ABOVE ON THIS _____ DAY OF _____, 2021.

VERNON P. TAYLOR
 COLORADO PLS NO. 25966,
 FOR AND ON BEHALF OF
 M&S CIVIL CONSULTANTS, INC.

NOTICE:

ACCORDING TO COLORADO LAW, YOU MUST COMMENCE ANY LEGAL ACTION BASED UPON ANY DEFECT IN THIS SURVEY WITHIN THREE YEARS AFTER YOU FIRST DISCOVER SUCH DEFECT. IN NO EVENT, MAY ANY ACTION BASED UPON ANY DEFECT IN THIS SURVEY BE COMMENCED MORE THAN TEN YEARS FROM THE DATE OF THE CERTIFICATION SHOWN HEREON.

PLANNING AND COMMUNITY DEVELOPMENT DEPARTMENT EXECUTIVE DIRECTOR CERTIFICATE:

THIS PLAT FOR "PAINT BRUSH HILLS FILING NO. 14" WAS APPROVED FOR FILING BY THE EXECUTIVE DIRECTOR OF THE EL PASO COUNTY PLANNING AND COMMUNITY DEVELOPMENT DEPARTMENT DIRECTOR ON THIS _____ DAY OF _____, 2021, SUBJECT TO ANY NOTES SPECIFIED HEREON AND ANY CONDITIONS INCLUDED IN THE RECORD OF ADMINISTRATIVE ACTION. THE DEDICATIONS OF LAND TO THE PUBLIC FOR STREETS AND EASEMENTS ARE ACCEPTED, BUT PUBLIC IMPROVEMENTS THEREON WILL NOT BECOME MAINTENANCE RESPONSIBILITY OF EL PASO COUNTY UNTIL PRELIMINARY ACCEPTANCE OF THE PUBLIC IMPROVEMENTS IN ACCORDANCE WITH THE REQUIREMENTS OF THE LAND DEVELOPMENT CODE AND ENGINEERING CRITERIA MANUAL AND THE SUBDIVISION IMPROVEMENTS AGREEMENT.

EXECUTIVE DIRECTOR, PLANNING AND COMMUNITY DEVELOPMENT DEPARTMENT _____ DATE _____

PIKES PEAK REGIONAL BUILDING ENUMERATIONS APPROVAL PROVIDED BY EMAIL DATED _____ 2021 AND RECORDED IN THE EL PASO COUNTY CLERK AND RECORDER RECORDS AT RECEPTION NUMBER _____

EL PASO COUNTY ASSESSOR _____ DATE _____

CLERK AND RECORDER:

STATE OF COLORADO)
) SS
COUNTY OF EL PASO)

I HEREBY CERTIFY THAT THIS INSTRUMENT WAS FILED FOR RECORD IN MY OFFICE AT _____ O'CLOCK _____M., THIS _____ DAY OF _____, 2021, A.D., AND DULY RECORDED UNDER RECEPTION NO. _____ OF THE RECORDS OF EL PASO COUNTY, COLORADO.

BY: _____
 CHUCK BROERMAN, EL PASO COUNTY CLERK AND RECORDER

FEES:

- FALCON BASIN DRAINAGE FEE: \$ 1,004,807.52
- BRIDGE FEE: \$ 138,031.79
- SCHOOL FEE: PAID WITH PREVIOUS FILING
- REGIONAL PARK FEE: \$ 104,608.00
- URBAN PARK FEE: \$ 66,080.00

SUMMARY:

224 LOTS	74.190 ACRES	83.71%
2 TRACTS	1.561 ACRES	1.76%
RIGHTS-OF-WAY	12.873 ACRES	14.53%
TOTAL	88.624 ACRES	100.00%

FINAL PLAT
 PAINT BRUSH HILLS FILING NO. 14
 JOB NO. 10-014
 DATE PREPARED: 06/26/2020
 DATE REVISED: 03/18/2021



PAINT BRUSH HILLS FILING NO. 14
A REPLAT OF TRACT E, PAINT BRUSH HILLS FILING 13E, BEING A PORTION
OF THE NE 1/4 SECTION 26, TOWNSHIP 12 SOUTH, RANGE 65 WEST OF
THE SIXTH PRINCIPAL MERIDIAN, EL PASO COUNTY, COLORADO

GENERAL PLAT NOTES:

1. **BASIS OF BEARINGS:** THE SECTION LINE BEING THE NORTH LINE OF TRACT A, TRACT E, AND A PORTION OF TRACT F "PAINT BRUSH HILLS FILING NO. 13E", AS RECORDED UNDER RECEPTION NO. 219714420, BEING MONUMENTED AT THE QUARTER CORNER COMMON TO SECTIONS 23 AND 26, T12S, R65W OF THE 6TH P. M. WITH A 2.5" ALUMINUM CAP ON NO. 6 REBAR STAMPED "1/4 COR, S23 S26, 1999, PLS 4842", AND AT THE SECTION CORNER COMMON TO SECTIONS 23, 24, 25 AND 26 WITH A 1.5" ALUMINUM CAP ON NO. 5 REBAR STAMPED "(PARTIALLY ILLEGIBLE) LS 9646", SAID LINE BEARS N88°44'51"E A DISTANCE OF 2640.30 FEET.
2. **FLOODPLAIN STATEMENT:** THE FLOOD INSURANCE RATE MAP (FIRM) PANEL NO. 08041C0535G DATED DECEMBER 7, 2018, HAS BEEN EXAMINED AS IT RELATES TO THE PROPERTY BEING PLATTED. THE PROPERTY LIES WITHIN ZONE X, AREA OF MINIMAL FLOOD HAZARD.
3. **TITLE COMMITMENT:** A COMMITMENT FOR TITLE INSURANCE ISSUED BY UNIFIED TITLE COMPANY, LLC AS AGENT FOR STEWART TITLE GUARANTY COMPANY WITH AN EFFECTIVE DATE OF JULY 3, 2018 AT 7:30AM, FILE NO. 59079 UTC, HAS BEEN EXAMINED AS IT RELATES TO THE PROPERTY BEING PLATTED.
 - i. (TC#9) THE PROPERTY MAY BE SUBJECT TO THE EFFECT OF NOTICE OF INCLUSION OF SUBJECT PROPERTY WITHIN THE FALCON FIRE PROTECTION DISTRICT, AS SET FORTH IN ORDER AND DECREE RECORDED DECEMBER 2, 1980 IN BOOK 3380 AT PAGE 670 AND RECORDED DECEMBER 2, 1980 IN BOOK 3380 AT PAGE 675, AND RECORDED FEBRUARY 17, 1981 IN BOOK 3404 AT PAGE 582, AND RECORDED FEBRUARY 17, 1981 IN BOOK 3404 AT PAGE 587.
 - ii. (TC#10) THE PROPERTY MAY BE SUBJECT TO NOTICE CONCERNING UNDERGROUND UTILITIES AS SET FORTH IN INSTRUMENT RECORDED MAY 9, 1983 IN BOOK 3718 AT PAGE 812.
 - iii. (TC#11) THE PROPERTY MAY BE SUBJECT TO TERMS, AGREEMENTS, PROVISIONS, CONDITIONS, OBLIGATIONS AND EASEMENTS AS CONTAINED IN POTABLE WATER SUPPLY AND SANITARY SEWER SERVICE AGREEMENT, RECORDED SEPTEMBER 14, 1987 IN BOOK 5421 AT PAGE 132. QUIT CLAIM IN CONNECTION THEREWITH RECORDED JANUARY 29, 1999 AT RECEPTION NO. 99014798.
 - iv. (TC#12) THE PROPERTY MAY BE SUBJECT TO THE EFFECT OF NOTICE OF INCLUSION OF SUBJECT PROPERTY WITHIN THE PAINT BRUSH HILLS METROPOLITAN DISTRICT, AS SET FORTH IN INSTRUMENT RECORDED SEPTEMBER 17, 1987 IN BOOK 5423 AT PAGE 2 AND RECORDED JANUARY 19, 2005 AT RECEPTION NO. 205008854 AND CORRECTION RECORDED FEBRUARY 3, 2005 AT RECEPTION NO. 205016961. AMENDED AND RESTATED RESOLUTION RECORDED MARCH 14, 2014 AT RECEPTION NO. 214020993. AMENDED AND RESTATED RESOLUTION RECORDED JUNE 7, 2016 AT RECEPTION NO. 216061171. AMENDED AND RESTATED RESOLUTION RECORDED MARCH 26, 2018 AT RECEPTION NO. 218033519. AMENDED AND RESTATED RESOLUTION RECORDED MAY 9, 2018 AT RECEPTION NO. 218052891.
 - v. (TC#13) THE PROPERTY MAY BE SUBJECT TO COVENANTS, CONDITIONS, RESTRICTIONS AND EASEMENTS, IF ANY, WHICH DO NOT CONTAIN A FORFEITURE OR REVERTER CLAUSE, (DELETING ANY RESTRICTIONS INDICATING ANY PREFERENCE, LIMITATION OR DISCRIMINATION BASED ON RACE, COLOR, RELIGION, SEX, HANDICAP, FAMILIAL STATUS OR NATIONAL ORIGIN) AS CONTAINED IN INSTRUMENT RECORDED SEPTEMBER 15, 1988 IN BOOK 5554 AT PAGE 514 AND ANY AND ALL AMENDMENTS AND/OR SUPPLEMENTS THERETO. ASSIGNMENT RECORDED JANUARY 22, 2018 AT RECEPTION NO. 218008145. FIRST AMENDMENT RECORDED JANUARY 29, 2018 AT RECEPTION NO. 2180180888.
 - vi. (TC#14) THE PROPERTY MAY BE SUBJECT TO TERMS, AGREEMENTS, PROVISIONS, CONDITIONS, OBLIGATIONS AND EASEMENTS AS CONTAINED IN RIGHT-OF-WAY EASEMENT TO MOUNTAIN VIEW ELECTRIC ASSOCIATION, INC., RECORDED MARCH 7, 1983 IN BOOK 3684 AT PAGE 492 AND RELEASE OF RIGHT OF WAY AND QUIT CLAIM DEED RECORDED NOVEMBER 21, 2005 AT RECEPTION NO. 205186521.
 - vii. (TC#15) THE PROPERTY MAY BE SUBJECT TO THE EFFECT RESOLUTION NO. 04-490, BY AND BEFORE THE BOARD OF COUNTY COMMISSIONERS, COUNTY OF EL PASO COUNTY, STATE OF COLORADO, AS SET FORTH IN INSTRUMENT RECORDED JANUARY 24, 2005 AT RECEPTION NO. 205011637.
 - viii. (TC#16) THE PROPERTY MAY BE SUBJECT TO THE EFFECT RESOLUTION NO. 04-491, BY AND BEFORE THE BOARD OF COUNTY COMMISSIONERS, COUNTY OF EL PASO COUNTY, STATE OF COLORADO, AS SET FORTH IN INSTRUMENT RECORDED JANUARY 31, 2005 AT RECEPTION NO. 205015059.
 - ix. (TC#17) THE PROPERTY MAY BE SUBJECT TO THE EFFECT RESOLUTION NO. 04-489, BY AND BEFORE THE BOARD OF COUNTY COMMISSIONERS, COUNTY OF EL PASO COUNTY, STATE OF COLORADO, AS SET FORTH IN INSTRUMENT RECORDED FEBRUARY 4, 2005 AT RECEPTION NO. 205017889.
 - x. (TC#18) THE PROPERTY MAY BE SUBJECT TO THE EFFECT RESOLUTION NO. 04-547, BY AND BEFORE THE BOARD OF COUNTY COMMISSIONERS, COUNTY OF EL PASO COUNTY, STATE OF COLORADO, AS SET FORTH IN INSTRUMENT RECORDED MARCH 9, 2005 AT RECEPTION NO. 205033555.
 - xi. (TC#19) THE PROPERTY MAY BE SUBJECT TO THE EFFECT OF THE COLORADO GROUND WATER COMMISSION FINDINGS AND ORDER, REGARDING THE PAINT BRUSH HILLS METROPOLITAN DISTRICT, AS SET FORTH IN INSTRUMENT RECORDED OCTOBER 05, 2005 AT RECEPTION NO. 205157500.
 - xii. (TC#20) THE PROPERTY MAY BE SUBJECT TO THE EFFECT RESOLUTION NO. 13-296, BY AND BEFORE THE BOARD OF COUNTY COMMISSIONERS, COUNTY OF EL PASO COUNTY, STATE OF COLORADO, REGARDING PUBLIC IMPROVEMENT DISTRICT NO. 2, AND PETITION OF INCLUSION, AS SET FORTH IN INSTRUMENT RECORDED JUNE 26, 2013 AT RECEPTION NO. 213083051.

GENERAL PLAT NOTES: (CONT.)

- xiii. (TC#21) THE PROPERTY MAY BE SUBJECT TO COVENANTS, CONDITIONS, RESTRICTIONS AND EASEMENTS, IF ANY, WHICH DO NOT CONTAIN A FORFEITURE OR REVERTER CLAUSE, (DELETING ANY RESTRICTIONS INDICATING ANY PREFERENCE, LIMITATION OR DISCRIMINATION BASED ON RACE, COLOR, RELIGION, SEX, HANDICAP, FAMILIAL STATUS OR NATIONAL ORIGIN) AS CONTAINED IN DECLARATION OF COVENANTS, CONDITIONS AND RESTRICTIONS, RECORDED SEPTEMBER 13, 2013 AT RECEPTION NO. 213117119 AND FIRST AMENDMENT RECORDED JANUARY 22, 2018 AT RECEPTION NO. 218008146 AND ASSIGNMENT RECORDED JANUARY 22, 2018 AT RECEPTION NO. 218008145 AND ANY AND ALL AMENDMENTS AND/OR SUPPLEMENTS THERETO. TRANSFER OF ARCHITECTURAL CONTROL COMMITTEE RECORDED NOVEMBER 29, 2017 AT RECEPTION NO. 217140585.
- xiv. (TC#22) THE PROPERTY MAY BE SUBJECT TO THE EFFECT OF MASTER PLAT OF PAINT BRUSH HILLS FILING NO. 13, AS SET FORTH IN INSTRUMENT RECORDED DECEMBER 9, 2013 AT RECEPTION NO. 213145991.
- xx. (TC#23) THE PROPERTY MAY BE SUBJECT TO TERMS, AGREEMENTS, PROVISIONS, CONDITIONS AND OBLIGATIONS AS CONTAINED IN SUBDIVISION IMPROVEMENTS AGREEMENT RECORDED DECEMBER 9, 2013 AT RECEPTION NO. 213145992.
- xvi. (TC#24) THE PROPERTY MAY BE SUBJECT TO NOTES, EASEMENTS AND RESTRICTIONS AS SHOWN ON THE PLAT OF PAINT BRUSH HILLS FILING NO. 13A RECORDED DECEMBER 9, 2013 AT RECEPTION NO. 213713413.
- xvii. (TC#25) THE PROPERTY MAY BE SUBJECT TO TERMS, AGREEMENTS, PROVISIONS, CONDITIONS AND OBLIGATIONS AS CONTAINED IN RESOLUTION NO.13-295 RECORDED DECEMBER 17, 2013 AT RECEPTION NO. 213148273.
- xviii. (TC#26) THE PROPERTY MAY BE SUBJECT TO TERMS, AGREEMENTS, PROVISIONS, CONDITIONS AND OBLIGATIONS AS CONTAINED IN RESOLUTION NO. 2013-12-01, CONCERNING THE IMPOSITION OF VARIOUS FEES, RATES, PENALTIES AND CHARGES FOR WATER AND SEWER SERVICES AND FACILITIES, RECORDED FEBRUARY 6, 2014 AT RECEPTION NO. 214010107. AMENDED AND RESTATED RESOLUTION NO. 2014-02-01, RECORDED JUNE 20, 2014 AT RECEPTION NO. 214053382. AMENDED AND RESTATED RESOLUTION NO. 2014-07-02 RECORDED JULY 23, 2014 AT RECEPTION NO. 214065368. CORRECTION RECORDED AUGUST 18, 2014 AT RECEPTION NO. 214074789 AND AUGUST 20, 2014 AT RECEPTION NO. 214075501. AMENDED AND RESTATED RESOLUTION NO. 2016-02-03 RECORDED FEBRUARY 23, 2016 AT RECEPTION NO. 216017724, RECORDED JUNE 5, 2017 AT RECEPTION NO. 217064880.
- xix. (TC#27) THE PROPERTY MAY BE SUBJECT TO TERMS, AGREEMENTS, PROVISIONS, CONDITIONS AND OBLIGATIONS AS CONTAINED IN RESOLUTION NO. 2015-11-06, RECORDED DECEMBER 3, 2015 AT RECEPTION NO. 215130544.
- xx. (TC#28) THE PROPERTY MAY BE SUBJECT TO TERMS, AGREEMENTS, PROVISIONS, CONDITIONS AND OBLIGATIONS AS CONTAINED IN RESOLUTION NO. 2015-06-01, RECORDED DECEMBER 4, 2015 AT RECEPTION NO. 215130828.
- xxi. (TC#29) THE PROPERTY MAY BE SUBJECT TO TERMS, AGREEMENTS, PROVISIONS, CONDITIONS AND OBLIGATIONS AS CONTAINED IN THE INFRASTRUCTURE CONSTRUCTION AND CONVEYANCE AGREEMENT RECORDED JANUARY 20, 2016 AT RECEPTION NO. 216005635.
- xxii. (TC#30) THE PROPERTY MAY BE SUBJECT TO TERMS, AGREEMENTS, PROVISIONS, CONDITIONS AND OBLIGATIONS AS CONTAINED IN THE INFRASTRUCTURE CONSTRUCTION AND CONVEYANCE AGREEMENT RECORDED JANUARY 20, 2016 AT RECEPTION NO. 216005637. PARTIAL ASSIGNMENT OF AND AMENDMENT RECORDED JULY 29, 2016 AT RECEPTION NO. 216084765. TERMINATION IN CONNECTION THEREWITH RECORDED FEBRUARY 23, 2017 AT RECEPTION NO. 217021665.
- xxiii. (TC#31) THE PROPERTY MAY BE SUBJECT TO TERMS, AGREEMENTS, PROVISIONS, CONDITIONS AND OBLIGATIONS AS CONTAINED IN RESOLUTION NO. 16-047 RECORDED FEBRUARY 9, 2016 AT RECEPTION NO. 216013026.
- xxiv. (TC#32) THE PROPERTY MAY BE SUBJECT TO TERMS, AGREEMENTS, PROVISIONS, CONDITIONS AND OBLIGATIONS AS CONTAINED IN RESOLUTION NO.2016-04-02 AS AMENDED AND RESTATED RESOLUTION OF THE BOARD OF DIRECTIONS OF THE PAINT BRUSH HILLS METROPOLITAN DISTRICT RECORDED JUNE 3, 2016 AT RECEPTION NO. 216060144 AND JUNE 7, 2016 AT RECEPTION NO. 216061171.
- xxv. (TC#33) THE PROPERTY MAY BE SUBJECT TO MINERAL QUIT CLAIM DEED CONVEYED TO BRADLEY MARKSHEFFEL, LLC, RECORDED OCTOBER 17, 2016 AT RECEPTION NO. 216119819.
- xxvi. (TC#34) THE PROPERTY MAY BE SUBJECT TO ANY TAXES OR ASSESSMENTS BY REASON OF THE INCLUSION OF THE LAND INTO THE EL PASO COUNTY PUBLIC IMPROVEMENT DISTRICT NO. 2 AS EVIDENCED BY RESOLUTION NO. 17-060, RECORDED FEBRUARY 2, 2017 AT RECEPTION NO. 217013713.
- xxvii. (TC#35) THE PROPERTY MAY BE SUBJECT TO TERMS, AGREEMENTS, PROVISIONS, CONDITIONS AND OBLIGATIONS AS CONTAINED IN INFRASTRUCTURE CONSTRUCTION, CONVEYANCE AND REIMBURSEMENT AGREEMENT RECORDED FEBRUARY 23, 2017 AT RECEPTION NO. 217021672. FIRST AMENDMENT RECORDED SEPTEMBER 28, 2017 AT RECEPTION NO. 217117401.
- xxviii. (TC#36) THE PROPERTY MAY BE SUBJECT TO TERMS, AGREEMENTS, PROVISIONS, CONDITIONS, OBLIGATIONS AND EASEMENTS AS CONTAINED IN PRIVATE DETENTION BASIN / STORMWATER QUALITY BEST MANAGEMENT PRACTICE MAINTENANCE AGREEMENT AND EASEMENT, RECORDED DECEMBER 20, 2017 AT RECEPTION NO. 217153396 AND AS AMENDED TO INCLUDE THE SUBJECT PROPERTY RECORDED _____.

GENERAL PLAT NOTES: (CONT.)

- xxix. (TC#37) THE PROPERTY MAY BE SUBJECT TO COVENANTS, CONDITIONS, RESTRICTIONS AND EASEMENTS, IF ANY, WHICH DO NOT CONTAIN A FORFEITURE OR REVERTER CLAUSE, (DELETING ANY RESTRICTIONS INDICATING ANY PREFERENCE, LIMITATION OR DISCRIMINATION BASED ON RACE, COLOR, RELIGION, SEX, HANDICAP, FAMILIAL STATUS OR NATIONAL ORIGIN) AS CONTAINED IN INSTRUMENT RECORDED DECEMBER 20, 2017 AT RECEPTION NO. 217153397 AND AS AMENDED TO INCLUDE THE SUBJECT PROPERTY RECORDED _____ AND ANY AND ALL AMENDMENTS AND/OR SUPPLEMENTS THERETO.
4. THE FOLLOWING REPORTS HAVE BEEN SUBMITTED IN ASSOCIATION WITH THE FINAL PLAT FOR THIS SUBDIVISION AND ARE ON FILE AT THE COUNTY PLANNING AND COMMUNITY DEVELOPMENT DEPARTMENT: TRANSPORTATION IMPACT STUDY; DRAINAGE REPORT; WATER MASTER PLAN; WASTEWATER DISPOSAL REPORT; GEOLOGY AND SOILS REPORT; FIRE PROTECTION REPORT; WILDFIRE HAZARD REPORT; NATURAL FEATURES REPORT; STORM WATER MANAGEMENT PLAN.
5. TRACT A AND B ARE FOR OPEN SPACE, PUBLIC DRAINAGE, PUBLIC UTILITIES, AND PUBLIC TRAILS TO BE OWNED AND MAINTAINED BY THE PAINT BRUSH HILLS METROPOLITAN DISTRICT. SAID TRACTS ARE TO BE CONVEYED BY SEPARATE DOCUMENT.
6. A DRIVEWAY PERMIT IS REQUIRED TO BE APPLIED FOR AND APPROVED BY EL PASO COUNTY PLANNING AND COMMUNITY DEVELOPMENT DEPARTMENT PRIOR TO THE ESTABLISHMENT OF ANY DRIVEWAY.
7. THE ADDRESSES EXHIBITED ON THIS PLAT ARE FOR INFORMATIONAL PURPOSES ONLY. THEY ARE NOT THE LEGAL DESCRIPTION AND ARE SUBJECT TO CHANGE.
8. ALL PROPERTY OWNERS ARE RESPONSIBLE FOR MAINTAINING PROPER STORM WATER DRAINAGE IN AND THROUGH THEIR PROPERTY. PUBLIC DRAINAGE EASEMENTS AS SPECIFICALLY NOTED ON THE PLAT SHALL BE MAINTAINED BY THE INDIVIDUAL LOT OWNERS UNLESS OTHERWISE INDICATED. STRUCTURES, FENCES, MATERIALS OR LANDSCAPING THAT COULD IMPEDE THE FLOW OF RUNOFF SHALL NOT BE PLACED IN DRAINAGE EASEMENTS.
9. MAILBOXES SHALL BE INSTALLED IN ACCORDANCE WITH THE EL PASO COUNTY DEPARTMENT OF TRANSPORTATION AND THE UNITED STATES POSTAL SERVICE REGULATIONS.
10. NO LOT OR INTEREST THEREIN, SHALL BE SOLD, CONVEYED, OR TRANSFERRED WHETHER BY DEED OR BY CONTRACT, NOR SHALL BUILDING PERMITS BE ISSUED, UNTIL AND UNLESS EITHER THE REQUIRED PUBLIC AND COMMON DEVELOPMENT IMPROVEMENTS HAVE BEEN CONSTRUCTED AND COMPLETED AND PRELIMINARILY ACCEPTED IN ACCORDANCE WITH THE SUBDIVISION IMPROVEMENTS AGREEMENT BETWEEN THE APPLICANT/ OWNER AND EL PASO COUNTY AS RECORDED UNDER RECEPTION NUMBER _____ IN THE OFFICE OF THE CLERK AND RECORDER OF EL PASO COUNTY, COLORADO OR, IN THE ALTERNATIVE, OTHER COLLATERAL IS PROVIDED TO MAKE PROVISION FOR THE COMPLETION OF SAID IMPROVEMENTS IN ACCORDANCE WITH THE EL PASO COUNTY LAND DEVELOPMENT CODE AND ENGINEERING CRITERIA MANUAL. ANY SUCH ALTERNATIVE COLLATERAL MUST BE APPROVED BY THE BOARD OF COUNTY COMMISSIONERS OR, IF PERMITTED BY THE SUBDIVISION IMPROVEMENTS AGREEMENT, BY THE DEVELOPMENT SERVICES DEPARTMENT DIRECTOR AND MEET THE POLICY AND PROCEDURE REQUIREMENTS OF EL PASO COUNTY PRIOR TO THE RELEASE BY THE COUNTY OF ANY LOTS FOR SALE, CONVEYANCE OR TRANSFER. THIS PLAT RESTRICTION MAY BE REMOVED OR RESOINDED BY THE BOARD OF COUNTY COMMISSIONERS OR, IF PERMITTED BY THE SUBDIVISION IMPROVEMENTS AGREEMENT, BY THE DEVELOPMENT SERVICES DEPARTMENT DIRECTOR UPON EITHER APPROVAL OF AN ALTERNATIVE FORM OF COLLATERAL OR COMPLETION AND PRELIMINARY ACCEPTANCE BY THE EL PASO BOARD OF COUNTY COMMISSIONERS OF ALL IMPROVEMENTS REQUIRED TO BE CONSTRUCTED AND COMPLETED IN ACCORDANCE WITH SAID SUBDIVISION IMPROVEMENTS AGREEMENT, THE PARTIAL RELEASE OF LOTS FOR SALE, CONVEYANCE OR TRANSFER MAY ONLY BE GRANTED IN ACCORDANCE WITH ANY PLANNED PARTIAL RELEASE OF LOTS AUTHORIZED BY THE SUBDIVISION IMPROVEMENTS AGREEMENT.
11. ALL STRUCTURAL FOUNDATIONS SHALL BE LOCATED AND DESIGNED BY A PROFESSIONAL ENGINEER, CURRENTLY LICENSED IN THE STATE OF COLORADO.
12. ALL STORM SEWER FACILITIES LYING OUTSIDE OF THE PUBLIC RIGHT-OF-WAY SHALL BE MAINTAINED BY THE PAINT BRUSH HILLS METROPOLITAN DISTRICT.
13. DEVELOPER SHALL COMPLY WITH FEDERAL AND STATE LAWS, REGULATIONS, ORDINANCES, REVIEW AND PERMIT REQUIREMENTS, AND OTHER AGENCY REQUIREMENTS, IF ANY, OF APPLICABLE AGENCIES INCLUDING, BUT NOT LIMITED TO, THE COLORADO DIVISION OF WILDLIFE, COLORADO DEPARTMENT OF TRANSPORTATION, U.S. ARMY CORPS OF ENGINEERS AND THE U.S. FISH AND WILDLIFE SERVICE REGARDING THE ENDANGERED SPECIES ACT, PARTICULARLY AS IT RELATES TO THE LISTED SPECIES.
14. THE SIGHT DISTANCE EASEMENT SHALL BE DEDICATED TO THE COUNTY. MAINTENANCE OF SIGHT DISTANCE EASEMENT SHALL BE THE RESPONSIBILITY OF THE PROPERTY OWNER. ANY OBJECT WITHIN THE SIGHT DISTANCE TRIANGLE OR EASEMENT MORE THAN 30 INCHES ABOVE THE FLOWLINE ELEVATION OF THE ADJACENT ROADWAY SHALL CONSTITUTE A SIGHT OBSTRUCTION, AND SHALL BE REMOVED OR LOWERED. THE OBJECT MAY INCLUDE BUT ARE NOT LIMITED TO BERMS, BUILDINGS, PARKED VEHICLES ON PRIVATE PROPERTY, CUT SLOPES, HEDGES, TREES, BUSHES, UTILITY CABINETS OR TALL CROPS.
15. WATER AND WASTEWATER SERVICE FOR THIS SUBDIVISION IS PROVIDED BY THE PAINT BRUSH HILLS METROPOLITAN DISTRICT, SUBJECT TO THE DISTRICT'S RULES, REGULATIONS AND SPECIFICATIONS.
16. ALL PROPERTY WITHIN THIS SUBDIVISION IS SUBJECT TO A DECLARATION OF COVENANTS AS RECORDED AT RECEPTION NO. 217153397 OF THE RECORDS OF THE EL PASO COUNTY CLERK AND RECORDER.

GENERAL PLAT NOTES: (CONT.)

17. ALL PROPERTY WITHIN THIS SUBDIVISION IS SUBJECT TO ROAD IMPACT FEES IN ACCORDANCE WITH THE EL PASO COUNTY ROAD IMPACT FEE PROGRAM (RESOLUTION NO. 19-471), AS AMENDED, AT THE TIME OF BUILDING PERMIT(S). PURSUANT TO RESOLUTION 17-060, APPROVED BY THE BOARD OF DIRECTORS, EL PASO COUNTY PUBLIC IMPROVEMENT DISTRICT 2 AND RECORDED IN THE RECORDS OF THE EL PASO COUNTY CLERK AND RECORDER AT RECEPTION NUMBER 217013713, THE PARCELS WITHIN THE PLATTED BOUNDARIES OF PAINT BRUSH HILLS FILING NO. 14 ARE INCLUDED WITHIN THE BOUNDARIES OF THE EL PASO COUNTY PUBLIC IMPROVEMENT DISTRICT 2 AND AS SUCH IS SUBJECT TO APPLICABLE ROAD IMPACT FEES AND MILL LEVY.
 - THE SUBDIVIDER(S) AGREES ON BEHALF OF HIM/HERSELF AND ANY DEVELOPER OR BUILDER SUCCESSORS AND ASSIGNEES THAT SUBDIVIDER AND/OR SAID SUCCESSORS AND ASSIGNS SHALL BE REQUIRED TO PAY TRAFFIC IMPACT FEES IN ACCORDANCE WITH THE EL PASO COUNTY ROAD IMPACT FEE PROGRAM RESOLUTION (RESOLUTION NO. 19-471), OR ANY AMENDMENTS THERETO, AT OR PRIOR TO THE TIME OF BUILDING PERMIT SUBMITTAL. THE FEE OBLIGATION, IF NOT PAID AT FINAL PLAT RECORDING, SHALL BE DOCUMENTED ON ALL SALES DOCUMENTS AND ON PLAT NOTES TO ENSURE THAT A TITLE SEARCH WOULD FIND THE FEE OBLIGATION BEFORE SALE OF THE PROPERTY.
18. THE INDIVIDUAL LOT PURCHASER(S) SHALL BE RESPONSIBLE FOR FINAL DESIGN, CONSTRUCTION, AND MAINTENANCE OF PRIVATE DETENTION POND/WATER QUALITY BMP(S) AS DESCRIBED IN THE APPROVED PRELIMINARY/FINAL DRAINAGE REPORT FOR THIS SUBDIVISION. FINAL DESIGN, CONSTRUCTION DRAWINGS AND DRAINAGE REPORT UPDATES FOR THE DETENTION POND/WATER QUALITY BMP(S) SERVING EACH LOT SHALL BE PROVIDED WITH SITE DEVELOPMENT PLAN SUBMITTALS. THE DETENTION POND/WATER QUALITY BMP(S) SHALL BE CONSTRUCTED AND COMPLETED PRIOR TO THE ISSUANCE OF ANY BUILDING PERMITS FOR THE SUBJECT LOTS. THE SUBDIVISION DEVELOPER IS RESPONSIBLE FOR PROVIDING FINANCIAL ASSURANCES AS INDICATED IN THE SUBDIVISION IMPROVEMENTS AGREEMENT AND ESTIMATE OF GUARANTEED FUNDS FOR ALL DETENTION PONDS/WATER QUALITY BMPS. ALL DETENTION PONDS/WATER QUALITY BMPS SHALL BE CONSTRUCTED PRIOR TO THE RELEASE OF SAID FINANCIAL ASSURANCES. INDIVIDUAL LOT PURCHASERS SHALL ENTER INTO A PRIVATE DETENTION BASIN/ STORMWATER QUALITY BMP MAINTENANCE AGREEMENT AND EASEMENT ("AGREEMENT") PRIOR TO THE ISSUANCE OF ANY BUILDING PERMITS FOR THE SUBJECT LOTS. IN THE CASE THAT THE DEVELOPER CONSTRUCTS THE DETENTION POND(S), THE DEVELOPER SHALL ENTER INTO AN AGREEMENT FOR EACH POND CONSTRUCTED.
19. GEOLOGIC CONDITIONS:
 - A GEOTECHNICAL INVESTIGATION WAS PREPARED BY RMG DATED OCTOBER 16, 2020 WITH ADDITIONAL INFORMATION PROVIDED DECEMBER 31, 2020. THE REPORT IDENTIFIED NO GEOLOGIC HAZARDS THAT WOULD PRECLUDE DEVELOPMENT OF THE SITE FOR CONSTRUCTION OF RESIDENTIAL STRUCTURES; HOWEVER, THE REPORT IDENTIFIED EXISTING GEOLOGIC AND ENGINEERING GEOLOGIC CONDITIONS THAT MAY REQUIRE SPECIAL CONSIDERATION FOR DEVELOPMENT AND CONSTRUCTION. IT IS NOTED THAT THESE CONDITIONS CAN BE MITIGATED WITH ENGINEERING DESIGN AND CONSTRUCTION METHODS COMMONLY EMPLOYED IN THE AREA. THESE CONDITIONS AND CONSTRUCTION RECOMMENDATIONS INCLUDE:
 - EXPANSIVE SOILS AND BEDROCK: MITIGATION OF EXPANSIVE SOILS MAY INCLUDE A 3 TO 4 FOOT OVEREXCAVATION AND REPLACEMENT WITH NON-EXPANSIVE STRUCTURAL FILL. (SEE SECTION 8.1 OF THE REPORT)
 - UNCONTROLLED/UNDOCUMENTED FILL: IF UNDOCUMENTED/UNCONTROLLED FILL IS ENCOUNTERED BELOW THE PROPOSED REFINEMENTS, IT WILL REQUIRE REMOVAL AND REPLACEMENT WITH STRUCTURAL FILL THAT HAS BEEN SELECTED, PLACED AND COMPACTED. TO VERIFY THE CONDITION OF THE COMPACTED SOILS, DENSITY TESTS SHOULD BE PERFORMED DURING PLACEMENT. (SEE SECTION 8.4 OF THE REPORT)
 - FOUNDATION DRAINS: A SUBSURFACE PERIMETER DRAIN IS RECOMMENDED AROUND PORTIONS OF THE STRUCTURES THAT WILL HAVE HABITABLE OR STORAGE SPACE LOCATED BELOW THE FINISHED GROUND SURFACE. THIS INCLUDES CRAWLSPACE AREAS IF APPLICABLE. (SEE SECTION 12.3 OF THE REPORT)
20. UNDERDRAIN SYSTEM IS TO BE MAINTAINED BY THE PAINT BRUSH HILLS METROPOLITAN DISTRICT.
21. LOTS 1 THROUGH 30 ARE ZONED RS20000. LOTS 31 THROUGH 224 ARE ZONED RS6000.

Add as a plat note. (Snippet from the preliminary plan.)

OWNERS.
15. Lots 1-30 (RS-20000) to allow split rail fence only along rear and side lot lines.

FINAL PLAT
 PAINT BRUSH HILLS FILING NO. 14
 JOB NO. 10-014
 DATE PREPARED: 06/26/2020
 DATE REVISED: 03/18/2021



212 N. WAHSATCH AVE., STE 305
 COLORADO SPRINGS, CO 80903
 PHONE: 719.955.5485

File: C:\100144-FBH 1A\FBH 14\Map\Survey\Plan\10-014 FBH #14 Final Plat.dwg Plotstamp: 5/18/2021 11:37 AM

PAINT BRUSH HILLS FILING NO. 14
 A REPLAT OF TRACT E, PAINT BRUSH HILLS FILING 13E, BEING A PORTION
 OF THE NE 1/4 SECTION 26, TOWNSHIP 12 SOUTH, RANGE 65 WEST OF
 THE SIXTH PRINCIPAL MERIDIAN, EL PASO COUNTY, COLORADO

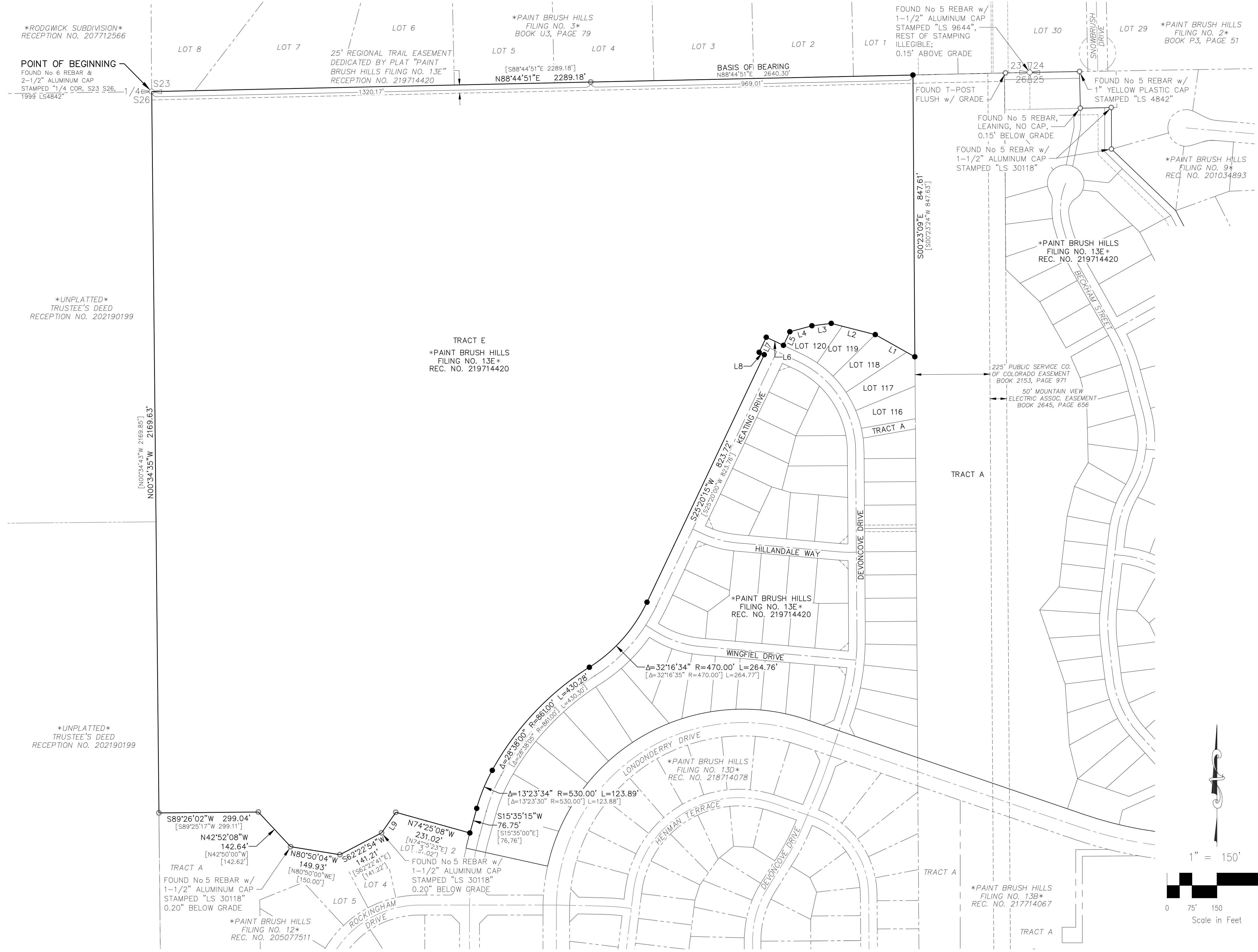

BOUNDARY LINE TABLE		
LINE #	DISTANCE	BEARING
L1	136.44 [136.45]	N60°39'45"W [N60°40'00"W]
L2	136.62 [136.63]	N75°42'34"W [N75°42'49"W]
L3	58.52 [58.52]	S82°53'35"W [S82°53'20"W]
L4	68.80 [68.80]	S74°48'58"W [S74°48'43"W]
L5	45.28 [45.27]	S25°20'15"W [S25°20'00"W]
L6	56.87 [56.93]	N64°40'00"W [N64°40'00"W]
L7	50.00 [50.00]	S25°20'00"W [S25°20'00"W]
L8	16.86 [16.93]	S64°40'00"E [S64°40'00"E]
L9	75.34 [75.37]	S34°46'45"W [S34°44'45"W]

- LEGEND:**
- SF SQUARE FEET
 - (R) RADIAL BEARING
 - (xxxx) ADDRESS
 - [B-D] RECORD DIMENSIONS
 - SET No 5 REBAR AND 1.25" ORANGE CAP STAMPED "MS CIVIL PLS 25966" FLUSH W/ EXISTING GRADE UNLESS NOTED OTHERWISE
 - FOUND No 5 REBAR AND 1-1/2" ALUMINUM CAP STAMPED "LS 30118" FLUSH W/ EXISTING GRADE UNLESS NOTED OTHERWISE
 - BOUNDARY LINE
 - PROPERTY LINE
 - RIGHT OF WAY LINE
 - CENTERLINE
 - EASEMENT LINE
 - ADJACENT SUBDIVISION LINE
 - ADJACENT PROPERTY LINE
 - EXISTING RIGHT OF WAY LINE
 - EXISTING CENTERLINE
 - EXISTING EASEMENT
 - MATCHLINE
 - *NOT A PART* PARCELS INDICATED WITH ASTERISK "*" ARE NOT A PART OF THIS SUBDIVISION

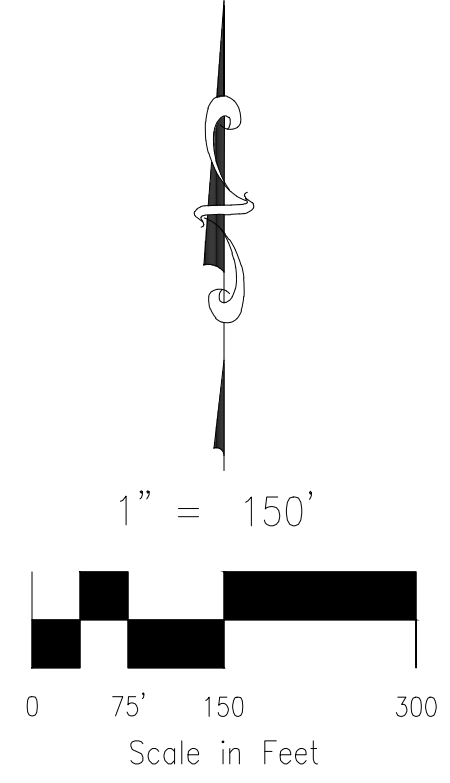

AS PLATTED

FINAL PLAT
 PAINT BRUSH HILLS FILING NO. 14
 JOB NO. 10-014
 DATE PREPARED: 06/26/2020
 DATE REVISED: 03/18/2021

CIVIL CONSULTANTS, INC.
 212 N. WAHSATCH AVE., STE 305
 COLORADO SPRINGS, CO 80903
 PHONE: 719.955.5485

File: C:\100144-FBH 14\FBH 14.dwg Survey\Plot\10-014 FBH #14 Final Plot.dwg Plotstamp: 3/18/2021 11:35 AM

PAINT BRUSH HILLS FILING NO. 14
A REPLAT OF TRACT E, PAINT BRUSH HILLS FILING 13E, BEING A PORTION
OF THE NE 1/4 SECTION 26, TOWNSHIP 12 SOUTH, RANGE 65 WEST OF
THE SIXTH PRINCIPAL MERIDIAN, EL PASO COUNTY, COLORADO

PAINT BRUSH HILLS FILING NO. 14
TOTAL AREA = 3,860,801 S.F.
88.632 AC +/-

RODGWICK SUBDIVISION
RECEPTION NO. 207712566

POINT OF BEGINNING
FOUND No 6 REBAR &
2-1/2" ALUMINUM CAP
STAMPED "1/4 COR. S23 S26,
1999 LS4842"

Planning Staff is
waiting on
confirmation that the
trail easement along
the western boundary
is not required as
depicted in the Parks
Master Plan. If it IS
required please be
prepared to label and
grant easement

UNPLATTED
TRUSTEE'S DEED
RECEPTION NO. 202190199

UNPLATTED
TRUSTEE'S DEED
RECEPTION NO. 202190199

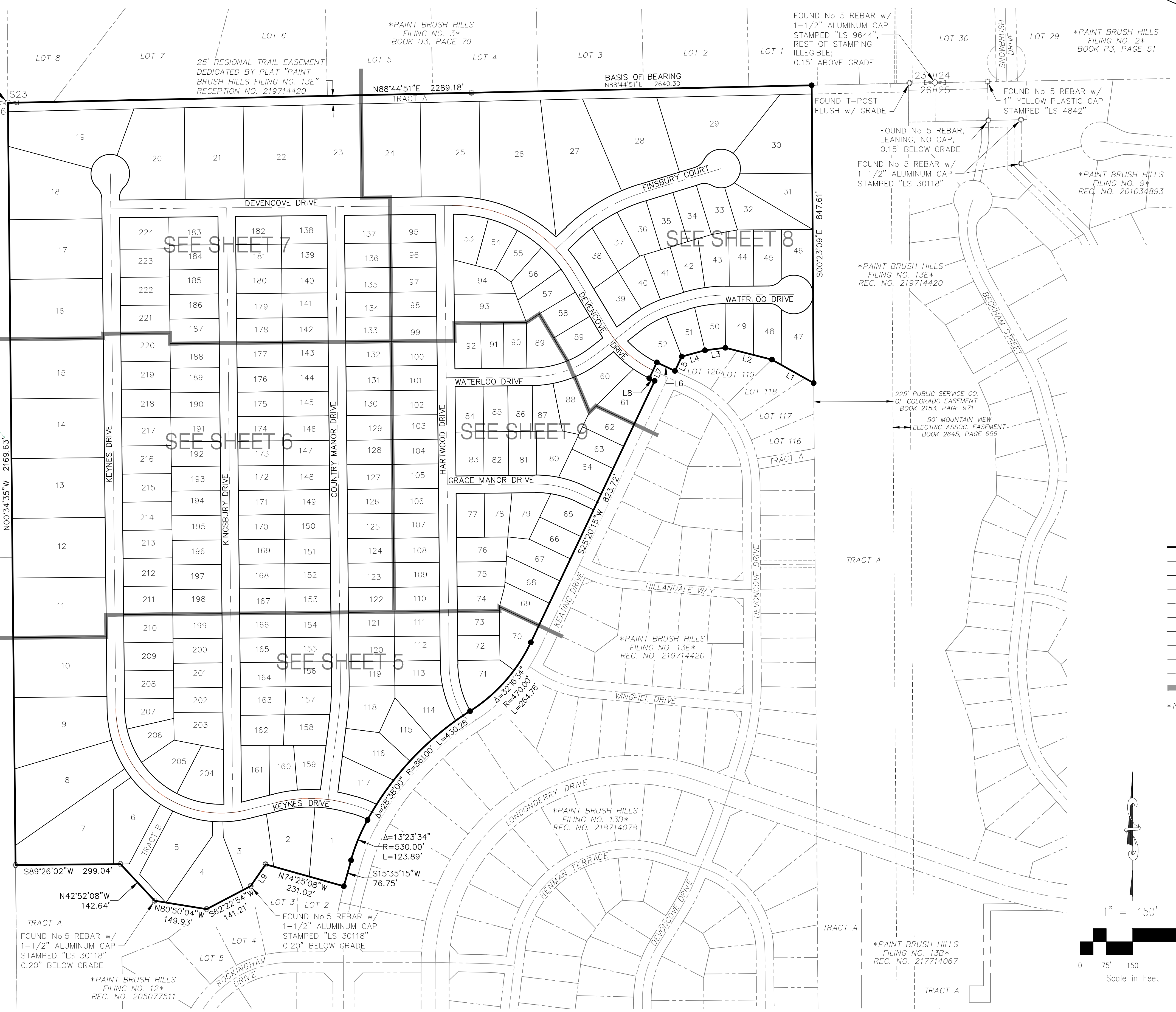
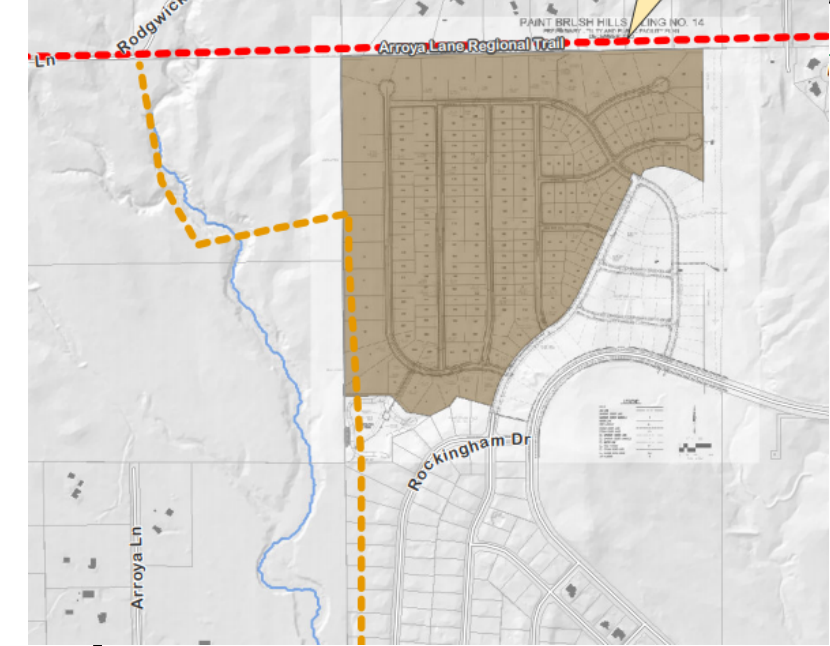

BOUNDARY LINE TABLE

LINE #	DISTANCE	BEARING
L1	136.44	N60°39'45"W
L2	136.62	N75°42'34"W
L3	58.52	S82°53'35"W
L4	68.80	S74°48'58"W
L5	45.28	S25°20'15"W
L6	56.87	N64°40'00"W
L7	50.00	S25°20'00"W
L8	16.86	S64°40'00"E
L9	75.34	S34°46'45"W

- LEGEND:**
- SF SQUARE FEET
 - (R) RADIAL BEARING
 - (xxxx) ADDRESS
 - [B-D] RECORD DIMENSIONS
 - SET No 5 REBAR AND 1.25" ORANGE CAP STAMPED "M&S CIVIL PLS 25966" FLUSH W/ EXISTING GRADE UNLESS NOTED OTHERWISE
 - FOUND No 5 REBAR AND 1-1/2" ALUMINUM CAP STAMPED "LS 30118", FLUSH W/ EXISTING GRADE UNLESS NOTED OTHERWISE
 - BOUNDARY LINE
 - PROPERTY LINE
 - RIGHT OF WAY LINE
 - CENTERLINE
 - EASEMENT LINE
 - ADJACENT SUBDIVISION LINE
 - ADJACENT PROPERTY LINE
 - EXISTING RIGHT OF WAY LINE
 - EXISTING CENTERLINE
 - EXISTING EASEMENT
 - MATCHLINE
 - *NOT A PART* PARCELS INDICATED WITH ASTERISK "*" ARE NOT A PART OF THIS SUBDIVISION

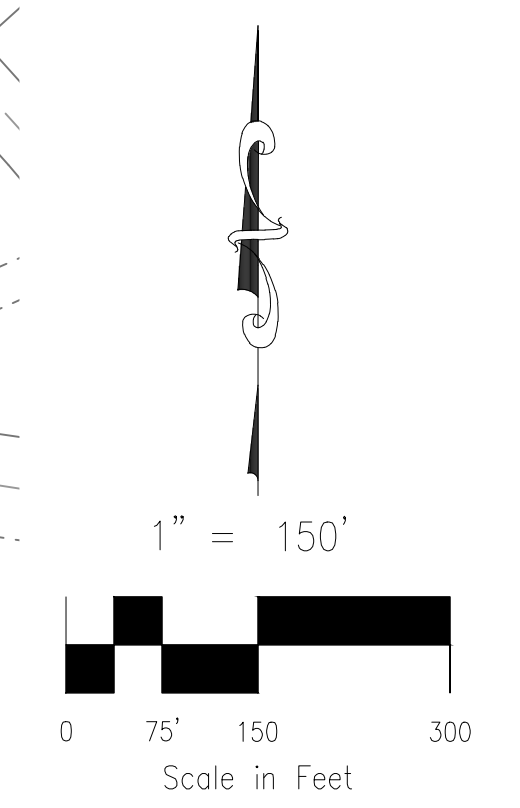

AS REPLATTED
(INDEX)
SEE SHEETS 5 THRU 9 FOR DETAIL

FINAL PLAT
PAINT BRUSH HILLS FILING NO. 14
JOB NO. 10-014
DATE PREPARED: 06/26/2020
DATE REVISED: 03/18/2021

M&S
CIVIL CONSULTANTS, INC.
212 N. WAHSATCH AVE., STE 305
COLORADO SPRINGS, CO 80903
PHONE: 719.955.5485

File: C:\100144-PBH 1A\FBH 1A\Survey\Plat\10-014 PBH #14 Final Plat.dwg Plotstamp: 3/18/2021 11:43 AM

LINE #	BEARING
(R)1	S02°00'40"W
(R)2	N06°19'21"W
(R)3	N00°54'25"W
(R)4	N04°23'24"E
(R)5	N25°04'26"E
(R)6	N32°07'52"E
(R)7	N52°21'17"E
(R)8	N57°38'43"E
(R)9	N83°20'48"W
(R)10	N89°54'51"W
(R)11	N89°57'31"W
(R)12	N78°59'55"E

CURVE #	RADIUS	DELTA	LENGTH
QC1	300.00	4°43'53"	24.77
QC2	300.00	11°04'07"	57.96
QC3	300.00	5°45'42"	30.17

CURVE #	RADIUS	DELTA	LENGTH
RC1	861.00	3°20'19"	50.17
RC2	275.00	10°43'11"	51.45
RC3	325.00	11°29'34"	65.19
RC4	425.00	4°23'31"	32.58
RC5	275.00	1°52'47"	9.02
RC6	861.00	3°16'12"	49.14
RC7	470.00	0°07'17"	1.00

CURVE #	RADIUS	DELTA	LENGTH
C1	861.00	0°05'07"	1.28
C2	325.00	5°17'49"	30.05
C3	325.00	7°03'26"	40.03
C4	325.00	5°17'27"	30.01
C5	700.00	0°34'57"	7.12
C6	700.00	0°40'09"	8.18
C7	750.00	0°37'29"	8.18

LINE #	DISTANCE	BEARING
QL1	5.42	N59°12'00"W
QL2	18.91	S75°00'00"E

LINE #	DISTANCE	BEARING
RL1	18.91	N75°00'00"W
RL2	18.91	S75°00'00"E

PAINT BRUSH HILLS FILING NO. 14
 A REPLAT OF TRACT E, PAINT BRUSH HILLS FILING 13E, BEING A PORTION OF THE NE 1/4 SECTION 26, TOWNSHIP 12 SOUTH, RANGE 65 WEST OF THE SIXTH PRINCIPAL MERIDIAN, EL PASO COUNTY, COLORADO

Planning Staff is waiting on confirmation that the trail easement along the western boundary is not required as depicted in the Parks Master Plan. If it is required please be prepared to label and grant easement

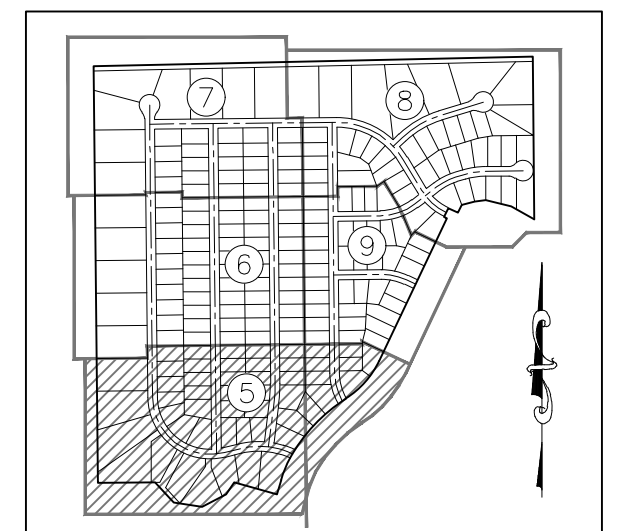
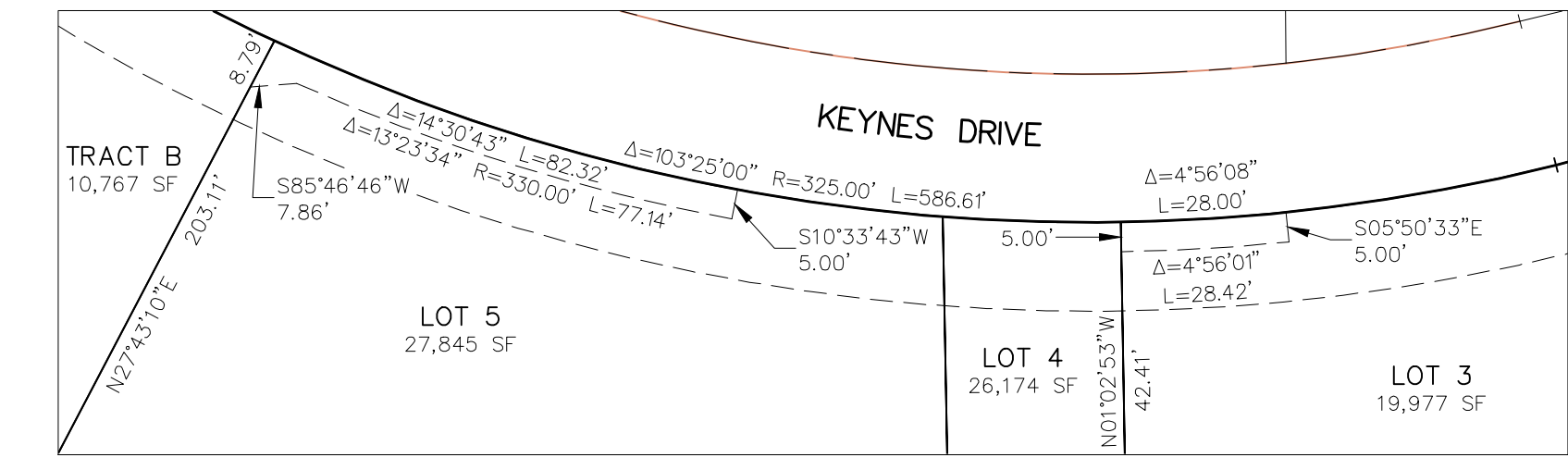

LOTS 3 AND 5 EASEMENT DETAIL
 STORM SYSTEM AND DRAINAGE
 SCALE: 1" = 30'
 5 FOOT SIDE AND FRONT LOT LINE EASEMENTS NOT SHOWN FOR CLARITY

SHEET INDEX
 NOT TO SCALE

MATCHLINE - SEE SHEET 6 OF 9

MATCHLINE - SEE SHEET 9 OF 9

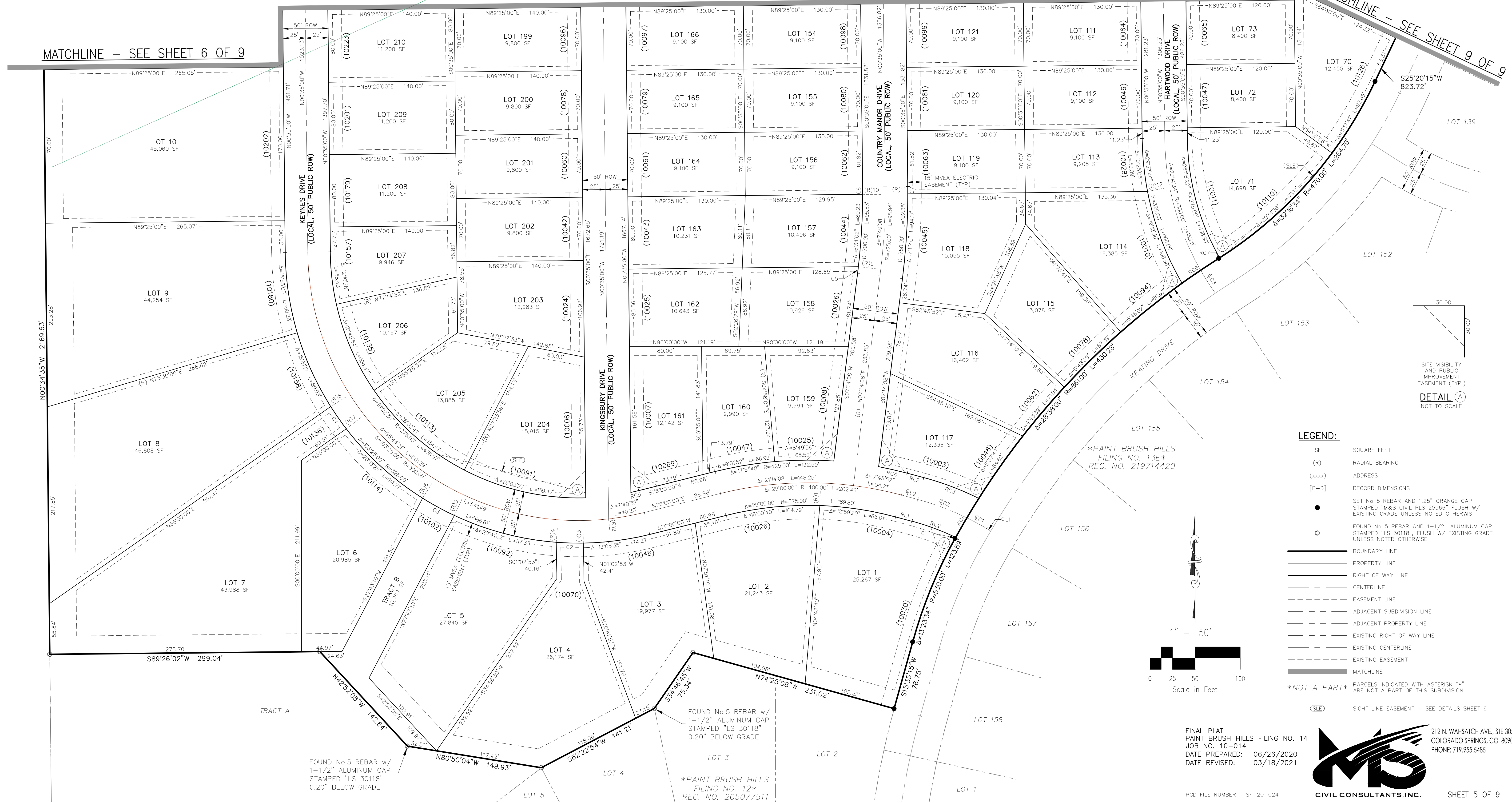

SITE VISIBILITY AND PUBLIC IMPROVEMENT EASEMENT (TYP.)
 DETAIL (A)
 NOT TO SCALE

LEGEND:

- SF SQUARE FEET
- (R) RADIAL BEARING
- (xxxx) ADDRESS
- [B-D] RECORD DIMENSIONS
- SET No 5 REBAR AND 1.25" ORANGE CAP STAMPED "M&S CIVIL PLS 25966" FLUSH W/ EXISTING GRADE UNLESS NOTED OTHERWISE
- FOUND No 5 REBAR AND 1-1/2" ALUMINUM CAP STAMPED "LS 30118" FLUSH W/ EXISTING GRADE UNLESS NOTED OTHERWISE
- BOUNDARY LINE
- PROPERTY LINE
- RIGHT OF WAY LINE
- CENTERLINE
- EASEMENT LINE
- ADJACENT SUBDIVISION LINE
- ADJACENT PROPERTY LINE
- EXISTING RIGHT OF WAY LINE
- EXISTING CENTERLINE
- EXISTING EASEMENT
- MATCHLINE
- *NOT A PART*
- SIGHT LINE EASEMENT - SEE DETAILS SHEET 9

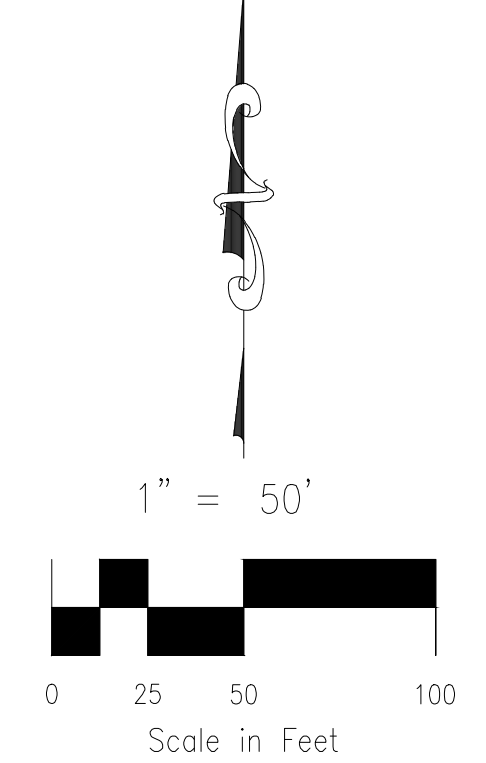

FINAL PLAT
 PAINT BRUSH HILLS FILING NO. 14
 JOB NO. 10-014
 DATE PREPARED: 06/26/2020
 DATE REVISED: 03/18/2021

212 N. WAHSATCH AVE., STE 305
 COLORADO SPRINGS, CO 80903
 PHONE: 719.955.5485

PAINT BRUSH HILLS FILING NO. 14
 A REPLAT OF TRACT E, PAINT BRUSH HILLS FILING 13E, BEING A PORTION
 OF THE NE 1/4 SECTION 26, TOWNSHIP 12 SOUTH, RANGE 65 WEST OF
 THE SIXTH PRINCIPAL MERIDIAN, EL PASO COUNTY, COLORADO

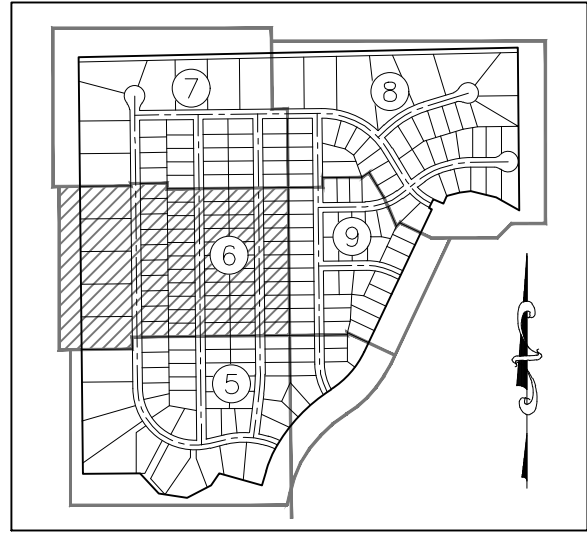

SHEET INDEX
NOT TO SCALE

- LEGEND:**
- SF SQUARE FEET
 - (R) RADIAL BEARING
 - (xxxx) ADDRESS
 - [B-D] RECORD DIMENSIONS
 - SET No 5 REBAR AND 1.25" ORANGE CAP STAMPED "M&S CIVIL PLS 25966" FLUSH W/ EXISTING GRADE UNLESS NOTED OTHERWISE
 - FOUND No 5 REBAR AND 1-1/2" ALUMINUM CAP STAMPED "LS 30118", FLUSH W/ EXISTING GRADE UNLESS NOTED OTHERWISE
 - BOUNDARY LINE
 - PROPERTY LINE
 - RIGHT OF WAY LINE
 - CENTERLINE
 - - - EASEMENT LINE
 - - - ADJACENT SUBDIVISION LINE
 - - - ADJACENT PROPERTY LINE
 - - - EXISTING RIGHT OF WAY LINE
 - - - EXISTING CENTERLINE
 - - - EXISTING EASEMENT
 - MATCHLINE
- *NOT A PART*** PARCELS INDICATED WITH ASTERISK "*" ARE NOT A PART OF THIS SUBDIVISION

MATCHLINE – SEE SHEET 7 OF 9

MATCHLINE – SEE SHEET 7 OF 9

MATCHLINE – SEE SHEET 9 OF 9



UNPLATTED TRUSTEE'S DEED REC. NO. 202190199

UNPLATTED TRUSTEE'S DEED REC. NO. 202190199

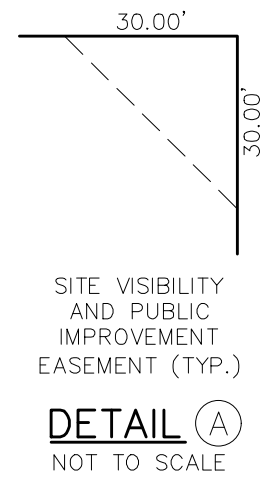
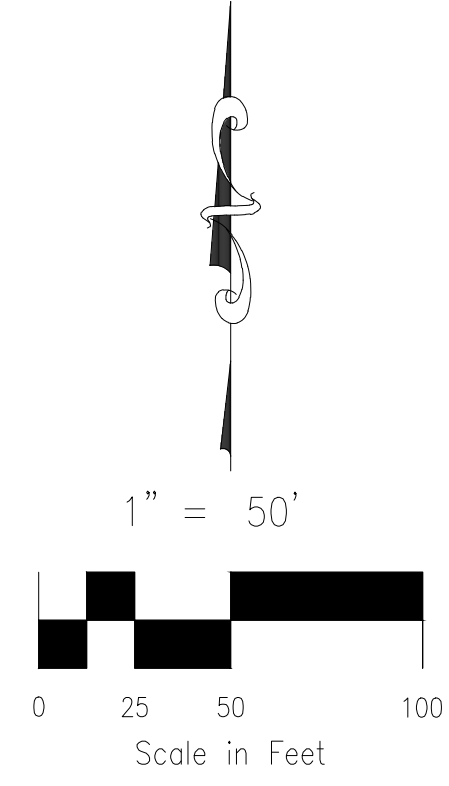

MATCHLINE – SEE SHEET 5 OF 9

MATCHLINE – SEE SHEET 5 OF 9

FINAL PLAT
 PAINT BRUSH HILLS FILING NO. 14
 JOB NO. 10-014
 DATE PREPARED: 06/26/2020
 DATE REVISED: 03/18/2021

CIVIL CONSULTANTS, INC.
 212 N. WAHSATCH AVE., STE. 305
 COLORADO SPRINGS, CO 80903
 PHONE: 719.955.5485

File: C:\10014A-FBH 1A\FBH 1A\Survey\Plot\10-014 FBH #14 Final Plat.dwg Plotstamp: 3/18/2021 11:44 AM

PAINT BRUSH HILLS FILING NO. 14
 A REPLAT OF TRACT E, PAINT BRUSH HILLS FILING 13E, BEING A PORTION
 OF THE NE 1/4 SECTION 26, TOWNSHIP 12 SOUTH, RANGE 65 WEST OF
 THE SIXTH PRINCIPAL MERIDIAN, EL PASO COUNTY, COLORADO

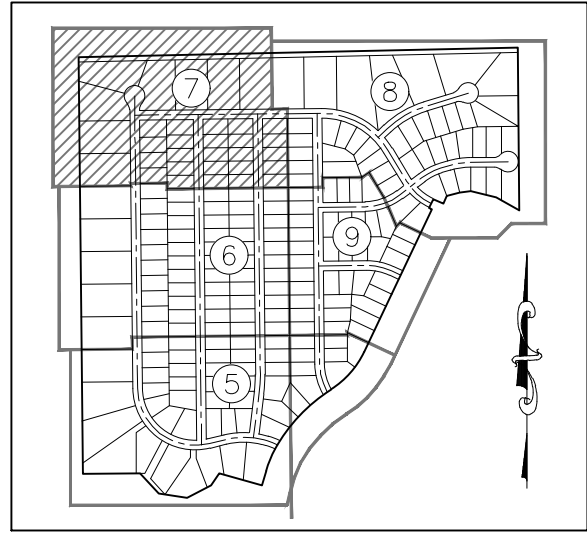

SHEET INDEX
NOT TO SCALE

- LEGEND:**
- SF SQUARE FEET
 - (R) RADIAL BEARING
 - (xxxx) ADDRESS
 - [B-D] RECORD DIMENSIONS
 - SET No 5 REBAR AND 1.25" ORANGE CAP STAMPED "M&S CIVIL PLS 25966" FLUSH W/ EXISTING GRADE UNLESS NOTED OTHERWISE
 - FOUND No 5 REBAR AND 1-1/2" ALUMINUM CAP STAMPED "LS 30118", FLUSH W/ EXISTING GRADE UNLESS NOTED OTHERWISE
 - BOUNDARY LINE
 - PROPERTY LINE
 - RIGHT OF WAY LINE
 - CENTERLINE
 - - - EASEMENT LINE
 - - - ADJACENT SUBDIVISION LINE
 - - - ADJACENT PROPERTY LINE
 - - - EXISTING RIGHT OF WAY LINE
 - - - EXISTING CENTERLINE
 - - - EXISTING EASEMENT
 - MATCHLINE
- *NOT A PART*** PARCELS INDICATED WITH ASTERISK "*" ARE NOT A PART OF THIS SUBDIVISION

RODGWICK SUBDIVISION
RECEPTION NO. 207712566

POINT OF BEGINNING
FOUND No 6 REBAR &
2-1/2" ALUMINUM CAP
STAMPED "1/4 COR, S23 S26,
1999 LS4842"

25' REGIONAL TRAIL EASEMENT
DEDICATED BY PLAT "PAINT
BRUSH HILLS FILING NO. 13E"
RECEPTION NO. 219714420

*PAINT BRUSH HILLS
FILING NO. 3*
BOOK U3, PAGE 79

MATCHLINE - SEE SHEET 8 OF 9

RIGHT-OF-WAY CURVE TABLE			
CURVE #	RADIUS	DELTA	LENGTH
RC8	45.00	45°34'23"	35.79
RC9	45.00	45°34'23"	35.79

RIGHT-OF-WAY LINE TABLE		
LINE #	DISTANCE	BEARING
RL3	4.02	S00°35'00"E



MATCHLINE - SEE SHEET 8 OF 9

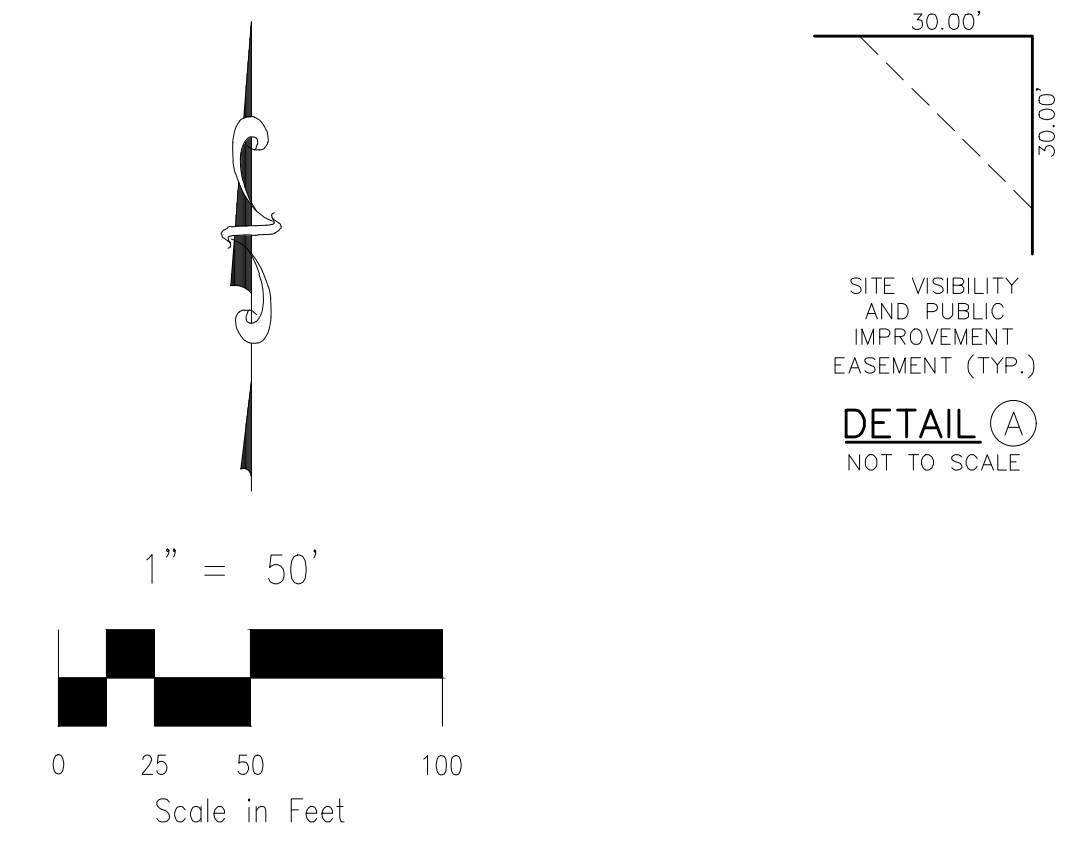

MATCHLINE - SEE SHEET 6 OF 9

MATCHLINE - SEE SHEET 6 OF 9

FINAL PLAT
 PAINT BRUSH HILLS FILING NO. 14
 JOB NO. 10-014
 DATE PREPARED: 06/26/2020
 DATE REVISED: 03/18/2021

CIVIL CONSULTANTS, INC.
 212 N. WAHSATCH AVE., STE 305
 COLORADO SPRINGS, CO 80903
 PHONE: 719.955.5485

File: C:\100144-FBH 1A\FBH 1A.dwg Survey\Plot\10-014 FBH #14 Final Plot.dwg Plotstamp: 3/18/2021 11:50 AM

PAINT BRUSH HILLS FILING NO. 14
 A REPLAT OF TRACT E, PAINT BRUSH HILLS FILING 13E, BEING A PORTION
 OF THE NE 1/4 SECTION 26, TOWNSHIP 12 SOUTH, RANGE 65 WEST OF
 THE SIXTH PRINCIPAL MERIDIAN, EL PASO COUNTY, COLORADO

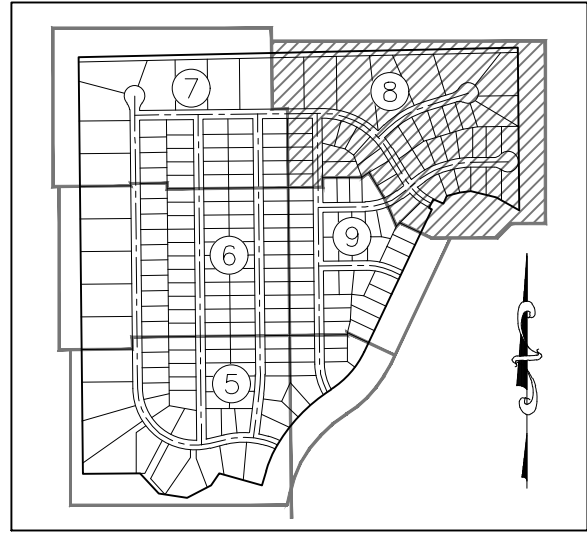

SHEET INDEX
NOT TO SCALE

RADIAL BEARING TABLE

LINE #	BEARING
(R)13	S10°06'52"W
(R)14	S37°26'40"E
(R)15	N74°29'50"W
(R)16	N42°15'48"W
(R)17	N10°11'04"W
(R)18	S38°15'14"E
(R)19	N39°58'47"E
(R)20	N22°10'01"W

RIGHT-OF-WAY CURVE TABLE

CURVE #	RADIUS	DELTA	LENGTH
RC10	45.00	45°34'23"	35.79
RC11	45.00	45°34'23"	35.79
RC12	425.00	9°07'40"	67.71
RC13	275.00	1°34'01"	7.52
RC14	325.00	2°22'16"	13.45
RC15	45.00	45°34'23"	35.79
RC16	45.00	45°34'23"	35.79

LOT & TRACT CURVE TABLE

CURVE #	RADIUS	DELTA	LENGTH
C8	55.00	32°14'01"	30.94
C9	55.00	32°04'44"	30.79
C10	325.00	3°54'34"	22.18
C11	425.00	0°12'03"	1.49
C12	55.00	7°42'32"	7.40
C13	55.00	5°12'13"	5.00
C14	375.00	2°52'04"	18.77
C15	275.00	4°10'24"	20.03
C16	375.00	4°41'35"	30.72

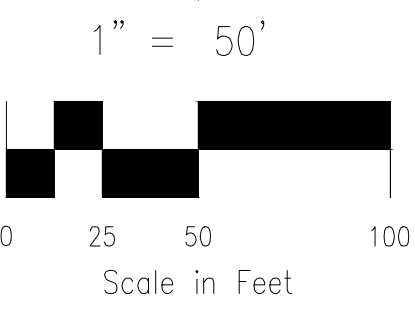

- LEGEND:**
- SF SQUARE FEET
 - (R) RADIAL BEARING
 - (xxxx) ADDRESS
 - [B-D] RECORD DIMENSIONS
 - SET No 5 REBAR AND 1.25" ORANGE CAP STAMPED "M&S CIVIL PLS 25966" FLUSH W/ EXISTING GRADE UNLESS NOTED OTHERWISE
 - FOUND No 5 REBAR AND 1-1/2" ALUMINUM CAP STAMPED "LS 30118" FLUSH W/ EXISTING GRADE UNLESS NOTED OTHERWISE
 - BOUNDARY LINE
 - PROPERTY LINE
 - RIGHT OF WAY LINE
 - CENTERLINE
 - - - EASEMENT LINE
 - - - ADJACENT SUBDIVISION LINE
 - - - ADJACENT PROPERTY LINE
 - - - EXISTING RIGHT OF WAY LINE
 - - - EXISTING CENTERLINE
 - - - EXISTING EASEMENT
 - MATCHLINE
 - PARCELS INDICATED WITH ASTERISK "*" ARE NOT A PART OF THIS SUBDIVISION
 - (SLE) SIGHT LINE EASEMENT - SEE DETAILS SHEET 9

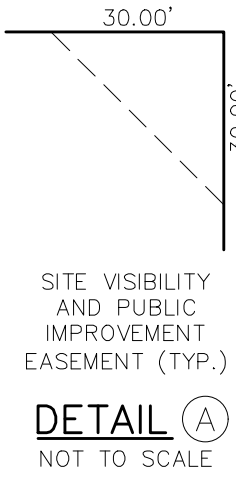

BOUNDARY LINE TABLE

LINE #	DISTANCE	BEARING
L1	56.87	N64°40'00"W
L2	50.00	S25°20'00"W
L3	16.86	S64°40'00"E



MATCHLINE - SEE SHEET 7 OF 9

MATCHLINE - SEE SHEET 7 OF 9

SEE SHEET 9 OF 9

MATCHLINE - SEE SHEET 9 OF 9

SEE SHEET 9 OF 9

PAINT BRUSH HILLS FILING NO. 13E REC. NO. 219714420

FINAL PLAT
 PAINT BRUSH HILLS FILING NO. 14
 JOB NO. 10-014
 DATE PREPARED: 06/26/2020
 DATE REVISED: 03/18/2021



212 N. WAHSATCH AVE., STE 305
 COLORADO SPRINGS, CO 80903
 PHONE: 719.955.5485

File: C:\100144-FBH 1A\FBH 14\Map\Survey\Plot\10-014 FBH #14 Final Plot.dwg Plotstamp: 3/18/2021 11:51 AM

PAINT BRUSH HILLS FILING NO. 14
 A REPLAT OF TRACT E, PAINT BRUSH HILLS FILING 13E, BEING A PORTION
 OF THE NE 1/4 SECTION 26, TOWNSHIP 12 SOUTH, RANGE 65 WEST OF
 THE SIXTH PRINCIPAL MERIDIAN, EL PASO COUNTY, COLORADO

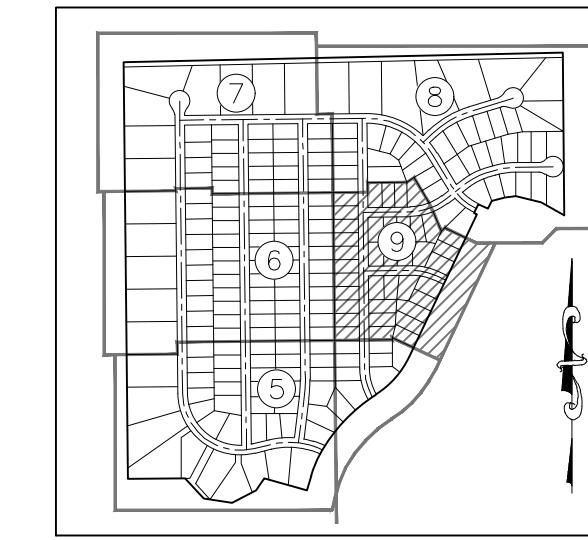

SHEET INDEX
NOT TO SCALE

LEGEND:

- SF SQUARE FEET
- (R) RADIAL BEARING
- (xxxx) ADDRESS
- [B-D] RECORD DIMENSIONS
- SET No 5 REBAR AND 1.25" ORANGE CAP STAMPED "M&S CIVIL PLS 25966" FLUSH W/ EXISTING GRADE UNLESS NOTED OTHERWISE
- FOUND No 5 REBAR AND 1-1/2" ALUMINUM CAP STAMPED "LS 30118", FLUSH W/ EXISTING GRADE UNLESS NOTED OTHERWISE
- BOUNDARY LINE
- PROPERTY LINE
- RIGHT OF WAY LINE
- CENTERLINE
- - - EASEMENT LINE
- - - ADJACENT SUBDIVISION LINE
- - - ADJACENT PROPERTY LINE
- - - EXISTING RIGHT OF WAY LINE
- - - EXISTING CENTERLINE
- - - EXISTING EASEMENT
- MATCHLINE
- *NOT A PART* PARCELS INDICATED WITH ASTERISK "*" ARE NOT A PART OF THIS SUBDIVISION

RADIAL BEARING TABLE

LINE #	BEARING
(R)20	N22°10'01"W
(R)21	S00°41'03"E
(R)22	S11°26'43"W
(R)23	S08°48'21"W

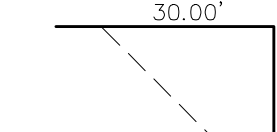

SITE VISIBILITY AND PUBLIC IMPROVEMENT EASEMENT (TYP.)
DETAIL A
NOT TO SCALE

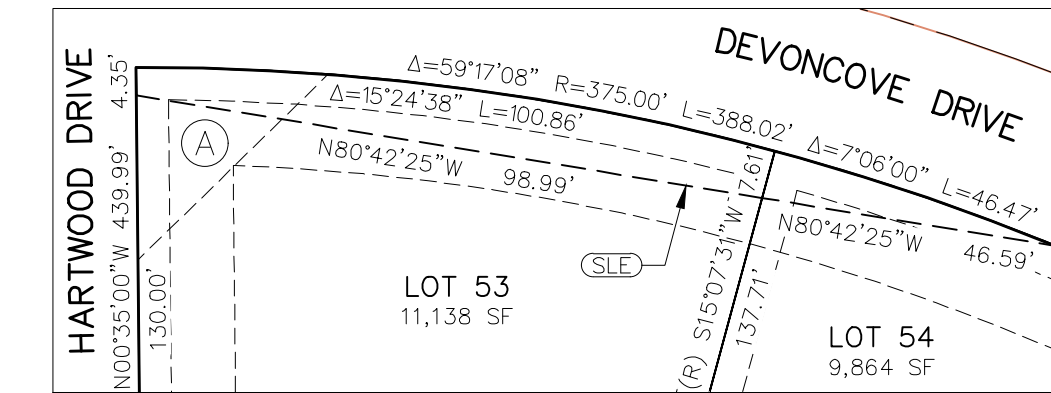

LOTS 53-54
SIGHT-LINE
EASEMENT DETAIL
SEE SHEET 8
SCALE: 1" = 30'

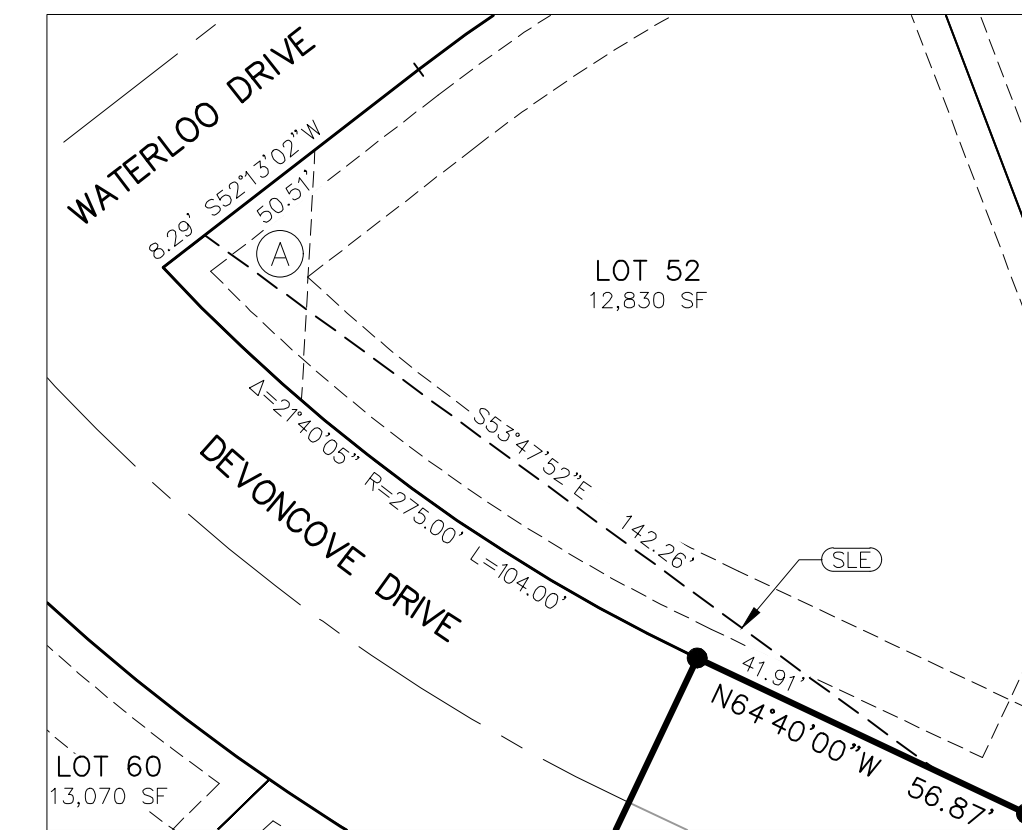

LOT 52
SIGHT-LINE
EASEMENT DETAIL
SEE SHEET 8
SCALE: 1" = 30'

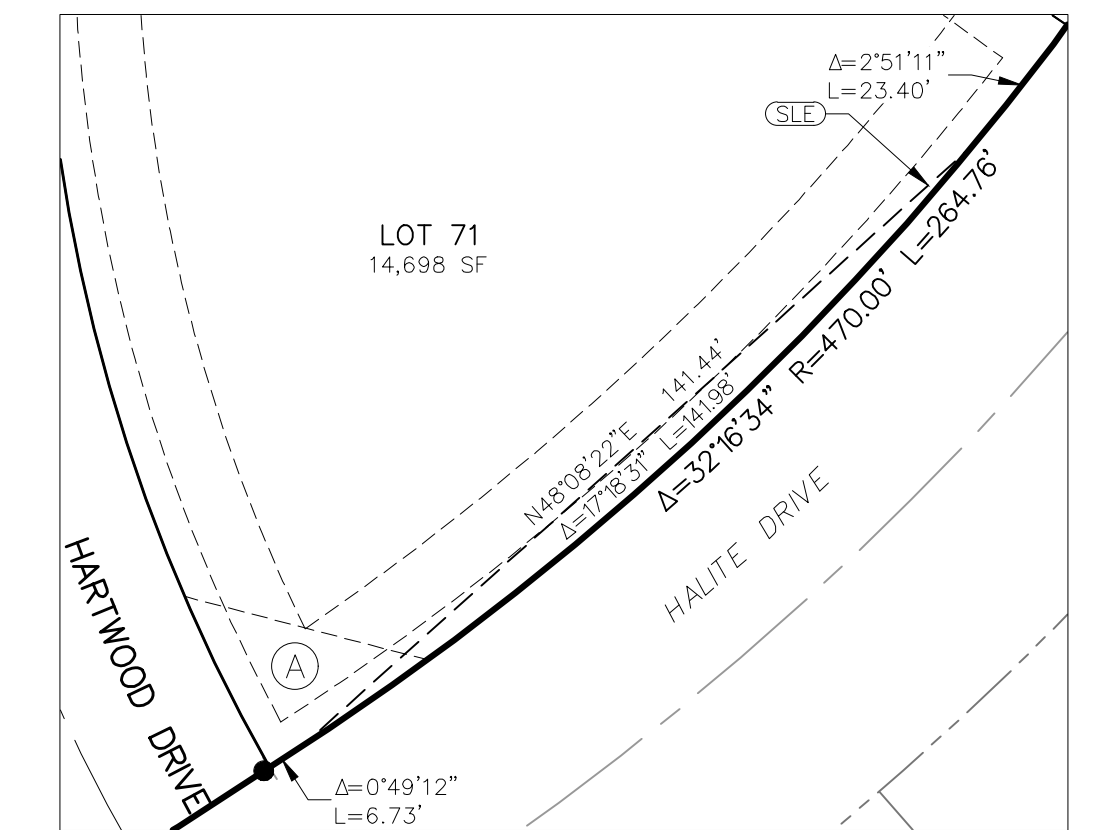

LOT 71
SIGHT-LINE
EASEMENT DETAIL
SEE SHEET 5
SCALE: 1" = 30'

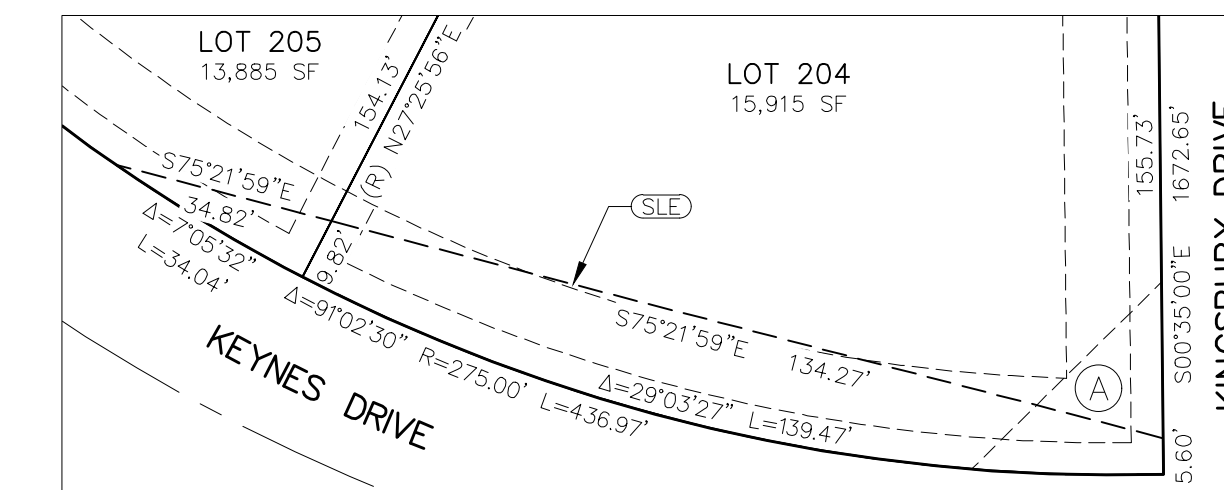

LOTS 204-205
SIGHT-LINE
EASEMENT DETAIL
SEE SHEET 5
SCALE: 1" = 30'

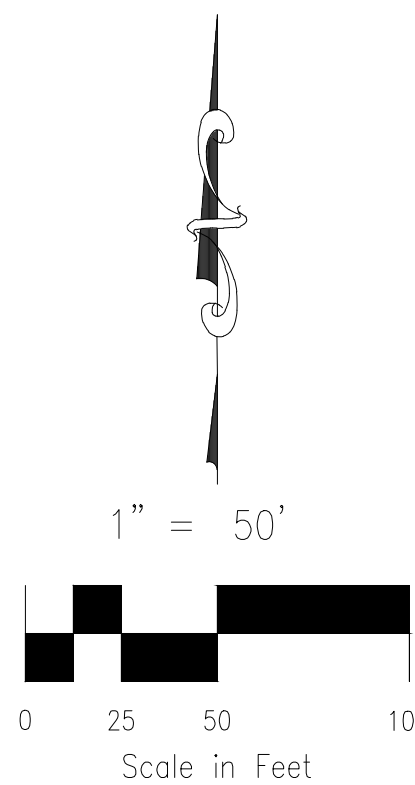

MATCHLINE - SEE SHEET 6 OF 9

MATCHLINE - SEE SHEET 5 OF 9

MATCHLINE - SEE SHEET 5 OF 9

SEE SHEET 8 OF 9

MATCHLINE - SEE SHEET 8 OF 9

MATCHLINE - SEE SHEET 8 OF 9

FINAL PLAT
 PAINT BRUSH HILLS FILING NO. 14
 JOB NO. 10-014
 DATE PREPARED: 06/26/2020
 DATE REVISED: 03/18/2021

212 N. WAHSATCH AVE., STE 305
 COLORADO SPRINGS, CO 80903
 PHONE: 719.955.5485

File: C:\100144-FBH 1A\FBH 1A\Survey\Plot\10-014 FBH #14 Final Plat.dwg Plotstamp: 3/18/2021 11:51 AM