

STORMWATER MANAGEMENT PLAN (SWMP)

For:

CLAREMONT BUSINESS PARK FIL. NO. 3

Located at:

1111 Meadowbrook Parkway

Prepared For:

**Developer: Hammers Construction, 1411 Woolsey Heights
Colorado Springs, CO 80915**

Contact: Dave Hammers, 719-570-1599

**Contractor: Hammers Construction, 1411 Woolsey Heights
Colorado Springs, CO 80915**

Contact: Robert Green, 719-570-1599

**Stormwater Manager: Hammers Construction, 1411 Woolsey Heights
Colorado Springs, CO 80915**

Contact: Josh Reed, 719-570-1599

Prepared by:



CIVIL CONSULTANTS, INC.

M&S Civil Consultants, Inc.

102 E. Pikes Peak Ave., Suite 500

Colorado Springs, CO 80903

719-491-0818

Virgil A. Sanchez, P.E.

Job. No. 44-037

EPC# PPR-20-000

Please add this number as well below the PPR#:

EGP-20-004

TABLE OF CONTENTS

Table of Contents	1
Stormwater Management Plan	
General Site Description	2
Existing Site Conditions	2
Soils	2
Soil Erosion Potential	2
Phasing Plan	2
Water Quality	3
Narrative Description of BMP Control Measures	3
Timing Schedule	4
Areas of Disturbance	4
Permanent Stabilization	4
Owners Inspections and Maintenance of BMP's	4
Soils Borings / Test and Groundwater	5
Site Run-off Characteristics	5
Stormwater Management Plan	
Introduction	6
Requirements	6
Floodplain Statement	6
Receiving Waters Descriptions	6
Existing Vegetation Description	6
Potential Pollution Sources	6
Anticipated Non-Stormwater Discharges	7
Erosion Sediment Controls	
Proposed Sequence of Construction Activities	7
Structural Practices	7
Non-Structural Practices	8
Materials Handling and Spill Practices	8
Revising BMP's and SWMP	8
Selecting Post-Construction BMPs	9
Inspections	9
Record Keeping	9

APPENDICES

Copy of CDPHE Application
Vicinity Map
Grading, Erosion, Stormwater Inspection Checklist
Spill Cleanup Instructions and Report Form
BMP Construction Details
SWMP Grading and Erosion Control Plans

STORMWATER MANAGEMENT PLAN (SWMP)

General Site Description

Claremont Business Park Filing No. 3 is located in the Northeast ¼ of the Northeast ¼ of Section 8, and the Southeast ¼ of the Southeast ¼ of Section 5, Township 14 South, Range 65 West of the 6th P.M. in El Paso County, Colorado. The site is bordered to the southeast by U.S. Highway 24 and to the northeast by N. Marksheffel Road, to the north and west by Meadowbrook Parkway, and to the south by a vacant, undeveloped lot. The site lies within the Sand Creek Drainage Basin. Flows from this site are tributary to Sand Creek.

The site consists of 13.660 acres which is currently vacant land with a relatively new roadway infrastructure for Meadowbrook Parkway and associated utilities services directly adjacent to the site. Vegetation is sparse, consisting of native grasses and weeds. Existing site terrain generally slopes from north to southwest at grade rates that vary between 1.2% and 2%. A soil retention wall runs along the eastside of the proposed site, next to U.S. Highway 24 and N. Marksheffel Road, and borders a large portion of the back of the proposed lots. The Claremont site is currently zoned "CS" and the proposed principal use for the site will be neighborhood commercial and light industrial.

Existing Site Conditions

In the existing condition, both the parcel and offsite contributing watershed lands are sparsely vegetated, with ground cover consisting primarily of native grasses ranging in density from fair to good. Slopes across the development typically range between 2% to 7% while offsite slopes located to the east of the nearly 38 acres are as steep as 10:1. Offsite flows reaching development are mainly from small fringe areas located along the north and eastern boundaries. A ridgeline which bisects the parcel, north to south functions to direct runoff to the southern boundary where it has historically collected. No natural springs, surface ground water are present on the property. No streams cross the property, and no batch plants exist or are proposed on this property.

Soils

Soils for this project are delineated by the map in the appendix as Ellicott Loamy Course Sand (28), Blendon Sandy Loam (10) and Blakeland Loamy Sand (8) and have been characterized as Hydrologic Soil Types "A" & "B". Soils in the study area are shown as mapped by S.C.S. in the "Soils Survey of El Paso County Area".

Soils Erosion Potential

The proposed onsite construction activities anticipate the potential for soil erosion. Onsite stormwater BMP management facilities are proposed to minimize and aid in soil erosion. Group A & B soils have a moderate infiltration rate when thoroughly wet. These consist chiefly of moderate deep or deep, moderately well drained or well drained soils that have moderately fine texture to moderately coarse texture. These soils have a moderate rate of water transmission. These soils thus have a moderate potential for erosion.

Phasing Plan

The Claremont Business Park Fil. No. 3 construction activities, such as grading, water quality pond, utility installation and street construction of Gary Watson Pt. shall be construction in the normal sequence of a project of this sort. The specific site development of each lot, such as building construction, parking lots and final landscaping shall be completed independently after the completion of the site development itself. Each lot shall submit an individually site development plan to County staff for review and approval.

Water Quality

Water quality for the southern portion of site is provided by a proposed Sand Filter Basins (SFB). This pond is designed to treat runoff from approx 6.53 acres, by providing 0.143 acre-feet of water quality storage. Per ECM section 1.7.1.C.1, 20% of the project site (not to exceed 1.0 acre) may be excluded from the 100% WQ treatment requirement per El Paso County criteria.

Flows tributary to the SFBs shall be released through an outlet structure into an existing storm sewer system located along Meadowbrook Parkway. The water quality basins will be private and shall be maintained by the property owner. Access shall be granted to the owner and El Paso County for access and maintenance of the private WQCV facility.

Narrative Description of BMP Control Measures

Installations of BMPs are staged in order to minimize the potential for pollutants in the stormwater discharge. The following stages will be used: establishment of perimeter controls, installation of temporary BMPs during soil disturbance and then finally installation of permanent controls. Descriptions of some of the available BMPs are listed in below stages:

Only clearing necessary for the installation of perimeter controls should be employed in the first stage of temporary BMPs installation. Silt fence and vehicle tracking should be installed as shown on the Grading & Erosion Control Plan. At this time, the El Paso County inspector should be notified to schedule an initial inspection. Rough grading of the site will precede construction of proposed underground utilities.

Once utilities and storm drain infrastructure have been constructed, installation of temporary BMPs will commence. Temporary BMPs for this site consist of Inlet Protection. Locations for a concrete washout area and temporary stockpile location will also be established. These locations are likely to be different than what is shown on the Grading and Erosion Control Plan that accompanies this report. Once these locations have been established, they should be added and denoted on the copy of the plan that will be kept with the site administrator.

The final stage is the installation of permanent BMPs where no further disturbance is anticipated. Upon completion of the permanent BMPs and all grading activities are completed, all disturbed areas not sodded or developed will be mulched and reseeded with native seed mix and may be watered until vegetative cover has been fully re-instated. At this point, the person responsible for inspection and maintenance can begin to address requirements for final stabilization. See construction details for installation and maintenance.

Specifically, the proposed project will use silt fence, a vehicle tracking control pad, concrete washout area, inlet protection, mulching and reseeded to mitigate the potential for erosion across the site. Trash, if any, will be hauled off on a regular basis.

No ground water, springs, or irrigation of non-stormwater discharge covered by CDPHE low risk guidance are known for this project.

No additional areas for storage of building materials, soil stockpiles or wastes are proposed for this project. The existing equipment storage yard for Timberline contractors will be utilized. Access for the project for construction equipment will be along the construction corridor. Construction vehicles (trucks) will access the site from adjacent public roadways.

There are no dedicated asphalt or concrete batch plants associated with this project.

Areas outside of the construction site boundary protected by silt fence, grading limits and/or limits of disturbance.

Timing Schedule

Anticipated Starting and Completion Time Period of Grading Activities:
June 2020 - October 2021

Expected Date on Which The Final Stabilization Will Be Completed:
October 2021

Areas of Disturbance

Total subject property site acreage: 8.330 ac
Total disturbed area of subject property: 6.662 ac

Permanent Stabilization

Final stabilization is reached when all soil-disturbing activities at the site have been completed, and uniform vegetative cover has been established by drill seeding and crimping with a density of at least 70% of pre-disturbance levels or equivalent permanent physical erosion reduction methods have been employed. The CDPHE Water Quality Division may, after consultation with the permittee and upon good cause, amend the final stabilization criteria for specific operations. At this time, the El Paso County inspector should be notified to schedule a final inspection. The conditions of the SWMP and General Permit for Stormwater Discharges associated with Construction Activity will remain in effect until Final Stabilization is achieved and a notice of inactivation is sent by the applicant to CDPHE Stormwater Quality Division. All pertinent records must be kept on file for at least 3 years from the date the site is finally stabilized.

Owner Inspections and Maintenance of BMP's

1. Make thorough inspection of the stormwater management system at least every 14 days.
2. Make thorough inspection of the stormwater management system after each precipitation event that causes runoff.
3. If any deficiencies are noted, they must be corrected immediately after being noted.
4. Records of the site inspections or modifications must be kept at the site unless alternate place is approved by the El Paso County inspector and must be made available upon request.
5. Inspections must take place where construction activity is complete, but lot is not sold.
6. Monthly inspections must take place on site where construction activity is complete, but vegetative cover is still being established.

Soil Borings / Test and Groundwater

A Geotec Engineering Report has been completed for the Claremont Business Park Fil. No. 2, by, Terracon, dated May 30, 2006, with an update Letter dated January 20, 2017, Proj No 23055071.

Site Run-Off Characteristics

The site runoff coefficients are:	Minor Storm	Major Storm
-Historic existing Conditions	0.09	0.36
-Roofs, Sidewalks, Paved Areas	0.90	0.96
-Landscaped and undeveloped areas	0.30	0.50

STORMWATER MANAGEMENT PLAN

Introduction

To: Site Inspector responsible for all Colorado Department of Public Health and Environment and El Paso County

Requirements:

The following stormwater management plan (SWMP) is a required item under the Construction Stormwater Discharge Permit. The primary goal for a SWMP is to improve water quality by reducing pollutants in stormwater discharges. Construction dewatering is a separate issue, and must be covered by the CDPHE Stormwater Quality Division's general permit for construction dewatering (regardless of the size of the construction project). Stormwater that mixes with ground water in an excavation is subject to the controls of a Construction Dewatering Permit. It is assumed that the SWMP will be completed and implemented at the time the project breaks ground, and will be revised if necessary as construction proceeds. This document must be kept at the construction site at all times and be made available to the public and any representative of any Water Quality Control Divisions if requested. Inspection guidance can be found at www.cdphe.state.co.us/ and El Paso County and City of Colorado Springs Storm Drainage Design Criteria. The inspections should be made at least every 14 days and after any precipitation or snowmelt event that causes surface erosion. El Paso County requires that the inspector must be contacted 48 hours prior to initial and final inspections. An inspection log entry should be completed with each inspection performed. The inspection log should be kept with the SWMP. The conditions of the SWMP and General Permit for Stormwater Discharges associated with the construction activity will remain in effect until final stabilization is achieved, and a notice of inactivation is sent to CDPHE Stormwater Quality Division. All pertinent records must be kept for at least 3 years from date the site is stabilized or sold.

Floodplain Statement

According to the Federal Emergency Management Agency (FEMA) Flood Insurance Rate Map (FIRM) Panel No. 08041C0756G, revised December 7, 2018. No portion of this site is located within the 100 year floodplain.

Receiving Water Description

The site is located with the greater Sand Creek Drainage Basin and is tributary to the Sand Creek Channel via the East Fork Sand Creek Sub-Tributary.

Existing Vegetation Description

Vegetation is sparse, consisting of native grasses. The site had experienced overlot grading activities within the last ten years. Existing site terrain generally slopes from northeast to southwest at grade rates that vary between 2% and 12%.

Potential Pollution Sources

Construction activities that will take place at this site may have an impact on the stormwater quality. These include, but are not limited to, portable toilets, materials storage, vehicle fueling, maintenance and vehicle tracking, dust, waste piles and dumpsters. The location of any of these activities not included on the initial site map should be added along with a description of the

measures used to prevent the discharge of these materials from the site. See construction details for installation and maintenance. There are no dedicated asphalt/concrete batch plants on site.

Anticipated Non-Stormwater Discharges

Non-stormwater discharges are caused by activities other than direct runoff from precipitation events. These include, but are not limited to natural springs. Any non-stormwater discharges that are not included in the initial map should be added along with a description of measures used to handle it. There are no known natural springs, temporary or permanent irrigation that would cause erosion on this project site.

EROSION SEDIMENT CONTROLS

Proposed Sequence of Construction Activities

1. Notify the inspector for initial inspection.
2. Clearing for necessary for perimeter controls.
3. Construct vehicle traffic control pad at entrance/exit of construction site.
4. Install lot perimeter controls, including silt fence, delineating project site as indicated on Site Map.
5. Complete remaining clearing and grubbing for project area. Install additional BMPs, as indicated on Site Map.
6. Grade site as indicated on Site Map.
7. Achieve Final Stabilization, as outlined in SWMP. Send inactivation notice to CDPHE.
8. See Construction Details for BMP Installation and Maintenance.

Any stockpile areas are to be contained with silt fence, or other acceptable measures to prevent erosion and sediment from leaving the area. All BMP's that may be in place need to be inspected and cleaned if sediment should leave the site and enter the streets. Erosion control measures shall be implemented in a manner that will protect properties and public facilities from the adverse effect of erosion and sedimentation as a result of construction and earthwork activities. The following practices are to be implemented for this site:

Structural Practices

In areas of sheet flow running off-site and at the top and bottom of steep slopes, silt fence will be used to trap sediment. Silt fence should be placed on the contour and in areas where the tributary area is less than one-quarter acre per 100' of silt fence. A vehicle traffic control pad will be installed at the entrance/exit of the site to reduce sediment tracking off-site.

Practices may include, but are not limited to straw bales, wattles/sediment control logs, silt fences, earth dikes, drainage swales, sediment traps, subsurface drains, pipe slope drains, inlet protection, outlet protection, gabions, and temporary or permanent sediment basins. All roads will be inspected to ensure that sediment from on-site construction activity is not being discharged with the stormwater. Sediment and debris that have been tracked off-site should be removed daily by shoveling or sweeping. See construction details for installation and maintenance.

Non-Structural Practices

Surface roughening may be used to reduce the amount of runoff and wind erosion from any given areas. Once the existing vegetation is cleared, watering should occur to help control fugitive dust. Disturbed areas where work is temporarily halted shall be temporarily stabilized within 21 calendar days after activity has ceased unless work is to be resumed within 30 calendar days after the activity has ceased. Other Non-Structural Practices may include soils erosion control measures for all slopes, channels, ditches, or any disturbed land area shall be completed within 21 calendar days after final grade, or final earth disturbance, has been completed. Disturbed areas and stockpiles, which are not at final grade but will remain dormant for longer than 30 days, shall also be mulched within 21 days after interim grading. An area that is going to remain in an interim state for more than 60 days shall also be seeded. All temporary soil erosion control measures and BMPs shall be maintained until permanent soil erosion control measures are implemented. See construction details for installation and maintenance.

Materials Handling and Spill Practices

Any substances with potential to contaminate either the ground or ground surface water shall be cleaned up immediately after discovery or contained until appropriate cleanup methods can be employed. Manufacturer's recommended methods for clean up shall be followed, along with proper disposal methods. Any discharge of hazardous materials must be handled in accordance with the Divisions Notification Requirement. All waste and debris created by construction activities at the site or removed from the site shall be disposed of in compliance with all laws, regulations and ordinances of the federal, state and local agencies. See construction details for Materials Handling and Spills.

Revising BMP's and SWMP

1. The plans must be amended, by the contractor, whenever there is a change in design, construction operation or maintenance that could have a significant effect on the potential for the discharge of pollutants to State Waters. It also must be amended if it is found to be ineffective in controlling pollutants present in stormwater.

2. Permittees are required to amend, adapt, and adjust their SWMP to accurately reflect phased construction changes and current conditions at the site. Plan modifications are broken into major and minor modifications which have differing requirements.

Major Modifications: Major modifications are changes to the SWMP that remove or add area to the project, modify the final hydrology or drainage of the final design, replace approved SWMP, or otherwise expand or contract the scope of the approved project. A revised SWMP and any revised supporting documents require review and approval of the local agency.

Minor Modifications: Minor modifications are changes to the SWMP that do not increase the scope or change hydrology of the project but; modify or improve specific BMPs in use at the site, indicate progression in phasing of the project, or specify relocation of previously approved BMPs within the project. Minor modifications can be made in the field by the permittee if the permittee can demonstrate that the modified soil erosion controls are equivalent to, or better than, the originally approved BMPs. Minor modifications must be thoroughly documented in the permittee's SWMP narrative, drawings and specifications.

3. The SWMP should be viewed as a "living document" throughout the lifetime of the project.

4. The plan must be signed in accordance with the general permit.
5. The plan must be made available, upon request, to CDPHE, United States Environmental Protection Agency, or operator of the local municipal storm sewer system, if applicable.
6. The following documents must be kept in a field office, trailer, shed, or vehicle that is onsite during normal working hours;
 1. The permit coverage letter from the Colorado Department of Public Health and Environment (CDPHE)
 2. The Stormwater Management Plan
 3. Site Inspection Records
 4. A copy of the Colorado General Permit for Stormwater Discharges from Construction Activities.

Selecting Post-Construction BMPs

Post Construction BMPs; Rock and revegetation including seeding, mulching and erosion control blanket will be final BMP's. Permanent stabilization will be achieved with 70% vegetative establishment and when permanent FSD facilities are constructed.

Inspections

Inspections should occur at least every 14 days and within 24 hours of a rainfall event producing runoff, usually this occurs with precipitation of 1/4 inch of rain or more. The local news weather report gives general rainfall amounts each day.

The inspection schedule should be routinely accomplished every 14 days and within 24 hours of the end of a storm event for the entire site with all BMP's evaluated for performance and need. Any BMP found to be ineffective should be re-accomplished or replaced with a new BMP to provide the level of protection needed. BMP's found to be no longer needed can be removed. Inspections should also be accomplished as soon as practical, at the end of a rain event causing surface erosion. The general procedure for correcting problems when identified should be documented in a log and a solution to correct the problem as soon as possible.

Record Keeping

Records should be retained for a minimum period of at least 3 years after the permit is terminated. Use log sheet provided in the Appendix of this report. The inspection logs and location of SWMP records should be kept onsite.

APPENDICES

COPY OF CDPHE APPLICATION



ASSIGNED PERMIT NUMBER	
Date Received	05/04/2020 13:12:49
MM DD YYYY HH:MM:SS	
Revised: 3-2016	

STORMWATER DISCHARGE ASSOCIATED WITH CONSTRUCTION ACTIVITIES APPLICATION
COLORADO DISCHARGE PERMIT SYSTEM (CDPS)

PHOTO COPIES, FAXED COPIES, PDF COPIES OR EMAILS WILL NOT BE ACCEPTED.

Any additional information that you would like the Division to consider in developing the permit should be provided with the application. Examples include effluent data and/or modeling and planned pollutant removal strategies.

Beginning July 1, 2016, invoices will be based on acres disturbed.
DO NOT PAY THE FEES NOW – Invoices will be sent after the receipt of the application.

Disturbed Acreage for this application (see page 4)

- Less than 1 acre (\$83 initial fee, \$165 annual fee)
- 1-30 acres (\$175 initial fee, \$350 annual fee)
- Greater than 30 acres (\$270 initial fee, \$540 annual fee)

A. PERMIT INFORMATION

Reason for Application

- NEW CERT
- MODIFICATION
- CHANGE OF CONTACT
- RENEW CERT
- TRANSFER
- TERMINATION

Existing Cert # _____

B. PERMITTED PROJECT/FACILITY INFORMATION

Facility Name: CBP Tract C filling #2 Original ID: _____
 Property Address 1: 1111 Meadowbrook Pkwy Property Address 2: _____ County: Colorado Springs
 City: Colorado Springs State: CO Zip Code: 80915
 Latitude : 38.853208 Longitude : -104.6838

SIC Code	Description
1629	Heavy construction, nec

Receiving Water Name	Receiving Water Type
East Sand Creek	Immediate
Fountain Creek	Ultimate

C. CONTACT INFORMATION

1) *OPERATOR – RESPONSIBLE OFFICIAL - the party that has operation control over day to day activities – may be the same as the Owner

Responsible Person (Title): Vice President First Name: Dave Last Name: Hammers
 Telephone No: 719-570-1599 Email Address: dhammers@hammersconstruction.com Organization: Hammers Construction, Inc.
 Mailing Address: 1411 Woolsey Heights
 City: Colorado Springs State: CO Zip Code: 80915

2) *PROPERTY OWNER (CO-PERMITTEE) RESPONSIBLE OFFICIAL

Responsible Person (Title): Vice President First Name: Dave Last Name: Hammers
 Telephone No: 719-570-1599 Email Address: dhammers@hammersconstruction.com Organization: Hammers Construction, Inc.
 Mailing Address: 1411 Woolsey Heights
 City: Colorado Springs State: CO Zip Code: 80915

3) *SITE CONTACT (local contact for questions relating to the facility & discharge authorized by this permit)

Responsible Person (Title): Vice President First Name: Dave Last Name: Hammers
 Telephone No: 719-570-1599 Email Address: dhammers@hammersconstruction.com Organization: Hammers Construction, Inc.
 Mailing Address: 1411 Woolsey Heights
 City: Colorado Springs State: CO Zip Code: 80915

4) *BILLING CONTACT

Responsible Person (Title): Vice President First Name: Dave Last Name: Hammers
 Telephone No: 719-570-1599 Email Address: dhammers@hammersconstruction.com Organization: Hammers Construction, Inc.
 Mailing Address: 1411 Woolsey Heights
 City: Colorado Springs State: CO Zip Code: 80915

5) OTHER CONTACT TYPES

Title	First Name	Last Name	Phone	Email	Address	City	State	Zip	Contact Type	Other

6) Former Permittee (transfer)

Responsible Person (Title): _____ First Name: _____ Last Name: _____
 Email Address: _____ Company: _____

D. LEGAL DESCRIPTION

Legal description: if subdivided, provide the legal description below, or indicate that it is not applicable. Do not supply Township/Range/Section or metes and bounds description of the site.

Subdivision(s): _____ Lot(s): _____ Block(s): _____

OR

- Not applicable (site has not been subdivided)
- Facility additional description info

E. AREA OF CONSTRUCTION SITE

Total area of construction site 8.33 acres

Total area of project disturbance 8.33 acres

F. NATURE OF CONSTRUCTION ACTIVITY

Check the appropriate box(s) or provide a brief description that indicates the general nature of the construction activities. (The full description of activities must be included in the Stormwater Management Plan.)

- Commercial Development Residential Development Highway and Transportation Development
 Pipeline and Utilities (including natural gas, electricity, water, and communications)
 Oil and Gas Exploration and Well Pad Development
 Non-structural and other development (i.e. parks, trails, stream realignment, bank stabilization, demolition, etc.)
 Other

G. ANTICIPATED CONSTRUCTION SCHEDULE

Construction Start Date: 04/27/2020 Final Stabilization Date: 07/01/2021

- Construction Start Date - This is the day you expect to begin ground disturbing activities, including grubbing, stockpiling, excavating, demolition, and grading activities.
• Final Stabilization Date - in terms of permit coverage, this is when the site is finally stabilized. This means that all ground surface disturbing activities at the site have been completed and all disturbed areas have either been built on, paved, or a uniform vegetative cover has been established with an individual plant density of at least 70 percent of pre-disturbance levels.
• Permit coverage must be maintained until the site is finally stabilized. Even if you are only doing one part of the project, the estimated final stabilization date must be for the overall project. If permit coverage is still required once your part is completed, the permit certification may be transferred to a new responsible operator.

SIGNATURE REQUIREMENTS:

TERMINATION CERTIFICATION

- By checking this box I understand that by submitting this notice of termination, I am no longer authorized to discharge stormwater associated with construction activity by the general permit. I understand that discharging pollutants in stormwater associated with construction activities to the waters of the State of Colorado, where such discharges are not authorized by a CDPS permit, is unlawful under the Colorado Water Quality Control Act and the Clean Water Act.
 STORMWATER MANAGEMENT PLAN CERTIFICATION (on new and renewals)
By checking this box "I certify under penalty of law that a complete Stormwater Management Plan, has been/or will be completed, prior to the commencement of any construction activity. Based on my inquiry of the person or persons who manage the system, or those persons directly responsible for gathering the information, the Stormwater Management Plan is/or will be, to the best of my knowledge and belief, true, accurate, and complete. I am aware that there are significant penalties for falsely certifying the completion of said SWMP, including the possibility of fine and imprisonment for knowing violations."

THIS PORTION OF THE SIGNATURE LANGUAGE IS REQUIRED ON ALL SUBMITTALS

"I certify under penalty of law that this document and all attachments were prepared under my direction or supervision in accordance with a system designed to assure that qualified personnel properly gather and evaluate the information submitted. Based on my inquiry of the person or persons who manage the system, or those persons directly responsible for gathering the information, the information submitted is to the best of my knowledge and belief, true, accurate and complete. I am aware that there are significant penalties for submitting false information, including the possibility of fine and imprisonment for knowing violations."

"I understand that submittal of this application is for coverage under the State of Colorado General Permit for Stormwater Discharges Associated with Construction Activity for the entirety of the construction site/project described and applied for, until such time as the application is amended or the certification is transferred, inactivated, or expired."

Signature of Operator

Date Signed

Name (printed)

Title

Signature of Owner

Date Signed

Name (printed)

Title

Signature: The applicant must be either the owner and operator of the construction site. Refer to Part B of the instructions for additional information. The application must be signed by the applicant to be considered complete. In all cases, it shall be signed as follows:

(Regulation 61.4 (1ei))

- a) In the case of corporations, by the responsible corporate officer is responsible for the overall operation of the facility from which the discharge described in the form originates
- b) In the case of a partnership, by a general partner.
- c) In the case of a sole proprietorship, by the proprietor.
- d) In the case of a municipal, state, or other public facility, by either a principal executive officer, ranking elected official, (a principal executive officer has responsibility for the overall operation of the facility from which the discharge originates).

FORMER PERMITTEE used for transfers

Signature (Legally Responsible Party)

Date

Name (printed)

Title

VICINITY MAP



VICINITY MAP

N.T.S.



20 BOULDER CRESCENT, SUITE 110
 COLORADO SPRINGS, CO 80903
 PHONE: 719.955.5485

GRADING, EROSION, STORMWATER
INSPECTION CHECKLIST

Appendix C Inspection Checklist – Grading Erosion, and Stormwater Quality Controls

CITY OF COLORADO SPRINGS

DATE/TIME:
INSPECTOR:
TYPE OF INSPECTION: Self-Monitoring_____
Initial _____ Compliance_____ Follow-Up_____
Reconnaissance_____ Complaint_____ Final_____

SITE:	DATE OF PERMIT:
ADDRESS:	
CONTRACTOR:	OWNER/OWNER'S REPRESENTATIVE:
CONTACT:	CONTACT:
PHONE:	PHONE:
STAGE OF CONSTRUCTION: Initial BMP Installation/Prior to Construction_____ Clearing & Grubbing_____	
Rough Grading_____ Finish Grading_____ Utility Construction_____ Building Construction_____	
Final Stabilization_____	

OVERALL SITE INSPECTION	YES/NO/N.A.	REMARKS/ACTIONS
Is there any evidence of sediment leaving the construction site? If so, note areas.		
Have any adverse impacts such as flooding, structural damage, erosion, spillage, or accumulation of sediment, debris or litter occurred on or within public or private property, wetlands or surface waters –to include intermittent drainageways and the City's stormwater system (storm sewers, gutters, ditches, etc.)?		
Are the BMPs properly installed and maintained?		
Have the BMPs been placed as shown on approved plans?		
Are the BMPs functioning as intended?		
Is work being done according to approved plans and any phased construction schedule?		
Is the construction schedule on track?		
Are drainage channels and outlets adequately stabilized?		
Is there any evidence of discharges or spills of fuels, lubricants, chemicals, etc.?		

BMP MAINTENANCE CHECKLIST	YES/NO/N.A.	REMARKS/ACTIONS NECESSARY
<p>SURFACE ROUGHENING</p> <p>Is the roughening consistent/uniform on slopes??</p> <p>Any evidence of erosion?</p>		
<p>TEMPORARY SEEDING</p> <p>Are the seedbeds protected by mulch?</p> <p>Has any erosion occurred in the seeded area?</p> <p>Any evidence of vehicle tracking on seeded areas?</p>		
<p>TEMPORARY SWALES</p> <p>Has any sediment or debris been deposited within the swales?</p> <p>Have the slopes of the swale eroded or has damage occurred to the lining?</p> <p>Are the swales properly located?</p>		
<p>VEHICLE TRACKING</p> <p>Is gravel surface clogged with mud or sediment?</p> <p>Is the gravel surface sinking into the ground?</p> <p>Has sediment been tracked onto any roads and has it been cleaned up?</p> <p>Is inlet protection placed around curb inlets near construction entrance?</p>		
<p>OTHER</p>		

FINAL INSPECTION CHECKLIST	YES/NO/N.A.	REMARKS/ACTIONS NECESSARY
Has all grading been completed in compliance with the approved Plan, and all stabilization completed, including vegetation, retaining walls or other approved measures?		
Has final stabilization been achieved – uniform vegetative cover with a density of at least 70 percent of pre-disturbance levels, and cover capable of adequately controlling soil erosion; or permanent, physical erosion methods?		
Have all temporary measures been removed?		
Have all stockpiles, construction materials and construction equipment been removed?		
Are all paved surfaces clean (on-site and off-site)?		
Has sediment and debris been removed from drainage facilities (on-site and off-site) and other off-site property, including proper restoration of any damaged property?		
Have all permanent stormwater quality BMPs been installed and completed?		

ADDITIONAL COMMENTS:
--

The items noted as needing action must be remedied no later than _____.

The contractor shall notify the inspector when all the items noted above have been addressed.

By signing this inspection form, the owner/owner's representative and the contractor acknowledge that they have received a copy of the inspection report and are aware it is their responsibility to take corrective actions by the date noted above. Failure to sign does not relieve the contractor and owner/owner's representative of their responsibility to take the necessary corrective action and of their liability for any damages that have occurred or may occur.

INSPECTOR'S SIGNATURE:	DATE:
OWNER/OWNER'S REPRESENTATIVE SIGNATURE:	DATE:
CONTRACTOR'S SIGNATURE:	DATE:

SPILL CLEANUP INSTRUCTIONS AND REPORT FORM

involving a radioactive or infectious material, or there is a release of a marine pollutant.

Spills and incidents that have or may result in a spill along a highway must be reported to the nearest law enforcement agency immediately. The Colorado State Patrol and CDPHE must also be notified as soon as possible. In the event of a spill of hazardous waste at a transfer facility, the transporter must notify CDPHE within 24 hours if the spill exceeds 55 gallons or if there is a fire or explosion.

The National Response Center should be notified as soon as possible after discovery of a release of a hazardous liquid or carbon dioxide from a pipeline system if a person is killed or injured, there is a fire or explosion, there is property damage of \$50,000 or more, or any nearby water body is contaminated.

The National Response Center and the Colorado Public Utilities Commission Gas Pipeline Safety Section must be notified as soon as possible, but not more than two hours after discovery of a release of gas from a natural gas pipeline or liquefied natural gas facility if a person is killed or injured, there is an emergency shutdown of the facility, or there is property damage of \$50,000 or more. The Colorado Public Utilities Commission should also be notified if there is a gas leak from a pipeline, liquefied natural gas system, master meter system or a propane system that results in the evacuation of 50 or more people from an occupied building or the closure of a roadway.

Oil and Gas Exploration

All Class I major events on federal lands, including releases of hazardous substances in excess of the CERCLA reportable quantity and spills of more than 100 barrels of fluid and/or 500 MCF of gas released, must be reported to the Bureau of Land Management (BLM) immediately. Spills of oil, gas, salt water, toxic liquids and waste materials must also be reported to the BLM and the surface management agency.

Spills of exploration and production (E&P) waste on state or private lands in excess of 20 barrels, and spills of any size that impact or threaten to impact waters of the state, an occupied structure, or public byway must be reported to the Colorado Oil and Gas Conservation Commission as soon as practicable, but not more than 24 hours after discovery. Spills of any

size that impact or threaten to impact waters of the state must be reported to CDPHE immediately. Spills that impact or threaten to impact a surface water intake must be reported to the emergency contact for that facility immediately after discovery. Spills of more than five (5) barrels of E&P waste must be reported in writing to the Oil and Gas Conservation Commission within 10 days of discovery.

REPORTING NUMBERS

National Response Center (24-hour)
1-800-424-8802

CDPHE Colorado Environmental Release and Incident Reporting Line (24-hour)
1-877-518-5608

Radiation Incident Reporting Line (24-hour)
303-877-9757

Colorado State Patrol (24-hour)
303-239-4501

Division of Oil and Public Safety
(business hours)
303-318-8547

Oil and Gas Conservation Commission
(business hours)
303-894-2100

Colorado Public Utilities Commission Gas Pipeline Safety Section (business hours)
303-894-2851

Local Emergency Planning Committees
(to obtain list, business hours)
720-852-6603



**Colorado Department
of Public Health
and Environment**

Environmental Spill Reporting

Colorado Department of Public Health and Environment
4300 Cherry Creek Drive South
Denver, CO 80246-1530

<http://www.cdphe.state.co.us>

January 2009

When a release of a hazardous material or other substance occurs to the environment, there are a number of reporting and notification requirements that must be followed by the company or individual responsible for the release. Most spills are covered by more than one reporting requirement, and **all** requirements must be met. In addition to verbal notification, written reports are generally required. This brochure briefly explains the major requirements. A more detailed description is provided in the "Reporting Environmental Releases in Colorado" Guidance Document, available on the web.

Releases that must be reported to the Colorado Department of Public Health and Environment (CDPHE) may be reported to the Colorado Environmental Release and Incident Reporting Line.

ENVIRONMENTAL SPILL REPORTING

CERCLA, EPCRA and RCRA

The Comprehensive Environmental Response, Compensation and Liability Act (CERCLA) and the Emergency Planning and Community Right-to-Know Act (EPCRA) require that a release of a reportable quantity or more of a hazardous substance to the environment be reported immediately to the appropriate authorities when the release is discovered.

Under CERCLA, reportable quantities were established for hazardous substances listed or designated under other environmental statutes. These include:

- all hazardous air pollutants (HAPs) listed under Section 112(b) of the Clean Air Act.
- all toxic pollutants designated under Section 307(a) or Section 311(b)(2)(A) of the Clean Water Act.
- all Resource Conservation and Recovery Act (RCRA) characteristic and listed hazardous wastes.
- any element, compound, or substance designated under Section 102 of CERCLA.

EPCRA established a list of extremely hazardous substances (EHS) that could cause serious irreversible health effects from accidental releases. Many substances appear on both the CERCLA and EPCRA lists. EPCRA extremely hazardous substances that are also CERCLA hazardous substances have the same reportable quantity (RQ) as under CERCLA. EPCRA extremely hazardous substances that are not listed under CERCLA have a reportable quantity that is equal to their threshold planning quantity (TPQ). A list of CERCLA reportable quantities is included in 40 CFR Section 302.4. A list of EPCRA threshold planning quantities is included in 40 CFR Part 355 Appendices A & B.

CERCLA-reportable releases must be reported immediately to the National Response Center (NRC), while EPCRA-reportable releases must be reported immediately to the National Response Center, the State Emergency Response Commission (SERC) and the affected Local Emergency Planning Committee (LEPC). If the release is an EPCRA extremely

hazardous substance, but not a CERCLA hazardous substance, and there is absolutely no potential to affect off-site persons, then only the State Emergency Planning Commission (represented by CDPHE for reporting purposes) and the Local Emergency Planning Committee need to be notified.

In the case of a release of hazardous waste stored in tanks, RCRA-permitted facilities and large quantity generators must also notify CDPHE within 24 hours of any release to the environment that is greater than one (1) pound.

Radiation Control

Each licensee or registrant must report to the Radiation Incident Reporting Line in the event of lost, stolen or missing licensed or registered radioactive materials or radiation machines, releases of radioactive materials, contamination events, and fires or explosions involving radioactive materials. Releases of radionuclides are reportable under CERCLA.

Clean Water Act

The Clean Water Act requires the person in charge of a facility or vessel to immediately report to the National Response Center all discharges of oil or designated hazardous substances to water. Oil means oil of any kind or form. Designated hazardous substances are included in the CERCLA list.

The Clean Water Act also requires that facilities with a National Pollutant Discharge Elimination System (NPDES) permit report to the National Response Center within 24 hours of becoming aware of any unanticipated bypasses or upsets that cause an exceedance of the effluent limits in their permit and any violations of their maximum daily discharge limits for pollutants listed in their permit.

A release of any chemical, oil, petroleum product, sewage, etc., which may enter waters of the state of Colorado (which include surface water, ground water and dry gullies and storm sewers leading to surface water) must be reported immediately to CDPHE. Any accidental discharge to the sanitary sewer system must be reported immediately to the local sewer authority and the affected wastewater treatment plant. For additional regarding releases to water, please see "Guidance for Reporting Spills under the Colorado

Water Quality Control Act and Colorado Discharge Permits" at <http://www.cdphe.state.co.us/op/wqcc/Resources/Guidance/spillguidance.pdf>.

Clean Air Act

Hazardous air pollutants (HAPs) are designated as hazardous substances under CERCLA. If a facility has an air permit but the permit does not allow for or does not specify the release of a substance, or if the facility does not have an air permit, then all releases in excess of the CERCLA / EPCRA reportable quantity for that substance must be reported to the National Response Center and CDPHE. If the facility releases more of a substance than is allowed under its air permit, the facility must also report the release. Discharges of a substance that are within the allowable limits specified in the facility's permit do not need to be reported.

Regulated Storage Tanks

Owners and operators of regulated storage tank systems must report a release or suspected release of regulated substances to the Division of Oil and Public Safety at the Colorado Department of Labor and Employment within 24 hours. Under this program, the reportable quantity for petroleum releases is 25 gallons or more, or any amount that causes a sheen on nearby surface water. Spills of less than 25 gallons of petroleum must be immediately contained and cleaned up. If cleanup cannot be accomplished within 24 hours, the Division of Oil and Public Safety must be notified immediately.

Spills of hazardous substances from tanks in excess of the CERCLA or EPCRA reportable quantity must be reported immediately to the National Response Center, CDPHE and the local fire authority, and to the Division of Oil and Public Safety within 24 hours.

Transportation and Pipelines

The person in physical possession of a hazardous material must notify the National Response Center as soon as practical, but not to exceed 12 hours after the incident, if as a direct result of the hazardous material, a person is killed or injured, there is an evacuation of the general public lasting more than an hour, a major transportation artery is shut down for an hour or more, the flight pattern of an aircraft is altered, there is fire, spillage or suspected contamination

WATER QUALITY
CONTROL
DIVISION

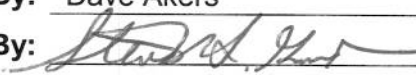
Policy No: WQE-10
Initiated By: Dave Akers
Approved By: 
Effective Date: 3/1/08
Revision No.: _____
Revision Date: _____

**Guidance for Reporting Spills under the Colorado Water Quality
Control Act and Colorado Discharge Permits**

I. Purpose

To provide guidance on applicable Colorado reporting requirements pursuant to § 25-8-601(2), C.R.S., that pertains to spills or discharges that may cause pollution of State waters. This guidance does not relieve an entity of any other statutory or regulatory requirements applicable to a spill. Facilities possessing a Colorado Discharge Permit System (CDPS) permit should follow applicable permit terms and conditions regarding spill reporting and response. This guidance is not intended to supersede or modify such permit terms and conditions or the applicable statute and regulations. This guidance does not limit the existing rights or responsibilities of persons with respect to spill reporting. For example, persons retain the right and responsibility to determine in the first instance whether a particular spill is covered by an existing permit or may cause pollution to State waters (i.e., surface or ground waters).

II. Statutory Requirement Addressed

Colorado Water Quality Control Act - Spill Reporting Requirements - § 25-8-601(2), C.R.S.

“Any person engaged in any operation or activity which results in a spill or discharge of oil or other substance which may cause pollution of the waters of the state contrary to the provisions of this article as soon as he has knowledge thereof, shall notify the division of such discharge.”

State waters means any and all surface and subsurface waters which are contained in or flow in or through this state, but does not include waters in sewage systems, waters in treatment works of disposal systems, waters in potable water distribution systems, and all water withdrawn for use until use and treatment have been completed (§ 25-8-103 (19), C.R.S.).

Examples of State waters include, but are not limited to, perennial streams, intermittent or ephemeral gulches and arroyos, ponds, lakes, reservoirs, irrigation canals or ditches, wetlands, stormwater conveyances (when they discharge to a surface water), and groundwater.

III. Policy/Applicability

The Division distinguishes between reporting requirements for spills that occur with respect to activities that result in a discharge that is authorized under a CDPS permit and those that are not. For non-permitted activities, or in the case of an activity where a permit does not address reporting of or response to a given spill, the Division recommends that the responsible person(s) take the following actions:

1. Immediately report spills that may result in a non-permitted discharge of pollutants to State waters to the Environmental Release and Incident Reporting Line at 1-877-518-5608;
2. Include the following information, if available, when notifying the Division of a spill:
 - a. The name of the responsible person and, if not reported by that person, the name of the person reporting the spill and the name of the responsible person if known;
 - b. An estimate of the date and time that the spill began or the actual date and time, if known;

- c. The location of the spill, its source (e.g., manhole, tanker truck), and identification of the type of material spilled (e.g., untreated wastewater, biosolids, specific chemical);
- d. The estimated volume of the spill and, if known, the actual date and time the spill was fully controlled/stopped.
- e. Whether the spill is ongoing and, if it is, the rate of flow and an estimate of the time that the spill will be fully controlled, if known;
- f. Measures that are being or have been taken to contain, reduce, and/or clean up the spill;
- g. A list of any potentially affected area and any known downstream water uses (e.g., public water supplies, irrigation diversions, public use areas such as parks or swim beaches) that will be or have been notified; and
- h. A phone number and e-mail to contact a representative of the responsible person that is in charge of the response. Where a non-responsible person is reporting the spill, they are encouraged, but not required, to provide contact information.

Reporting and management of spills that occur with respect to activities resulting in a discharge authorized under a permit should be performed in accordance with the specific requirements of that permit. If the permit does not provide specific reporting or management response requirements for a given spill that may pollute State waters, the Division recommends that the responsible person report the spill in accordance with the procedures listed above.

This guidance only addresses reporting requirements under the Division's authority. The person or entity engaged in any operation or activity that results in a spill is responsible for any other applicable reporting requirements associated with the spill to other regulatory agencies.

Section 25-8-601(2), C.R.S. only addresses spill reporting to the Division. Section 25-8-202(7), C.R.S. provides certain water quality responsibilities to other state "implementing agencies." The Division's position is that, where a spill to the ground that may impact ground water only is fully and timely reported to an implementing agency having jurisdiction over that spill, the intent of section 601(2) has been fulfilled, and the spill need not also be reported to the Division. The Division suggests that the responsible person confirm with the implementing agency that a spill falls under the jurisdiction of the implementing agency at the time it is reported in order to avoid possible legal liability should it fall under the Division's jurisdiction.

IV. Division Examples of Non-Reportable Spills

The Division has identified the following examples of types of spills that are considered "non-reportable" under § 25-8-601(2), C.R.S. Documentation of such spills, including the information listed in section III.2.a – III.2.f above, should be maintained by the responsible person for Division review for a period of three years.

1. A spill to a generally impervious surface or structure (e.g., paved street/parking lot, storm sewer, warehouse floor, manhole, vault, concrete basement), or onto soils, that is fully contained in/on the impervious surface/structure or soils, or that is managed in a manner so that it will not reach State waters at the time of the spill or in the future. Such spills that are cleaned up within 24 hours will be considered by the Division to have no potential to reach State waters. However, even if such spills are not cleaned up within 24 hours, the responsible person may be able to "fully contain" or otherwise manage a spill such that it will not reach State waters. Where there is a sump pump present in a basement to which a spill occurred, the responsible person must establish that the pump did not discharge to State waters during the time between the start of the spill and the completion of clean-up in accordance with best management practices.
2. A spill or discharge that is managed consistent with best management practices that are established in accordance with a CDPS discharge permit or any Water Quality Control Commission-adopted control regulation related to spill management or reporting.
3. A spill of potable water from a public water system that does not reach surface waters.

<input checked="" type="checkbox"/> Field Services - Grand Junction 222 South 6th Street, Room 232 Grand Junction, CO 81501 Telephone: 970-248-7150 Fax: 970-248-7198 Contact email: michelle.thiebaud@state.co.us	<input type="checkbox"/> Field Services - Pueblo 140 Central Main, Suite 300 Pueblo, CO 81003 Telephone: 719-295-5060 Fax: 719-543-8441 Contact email: carol.keeper@state.co.us	<input type="checkbox"/> Field Services - Denver 4300 Cherry Creek Dr. South, B2 Denver, Colorado 80246-1530 Phone: 303-692-3650 Fax: 303-782-0390 Contact email: annemarie.goolsby@state.co.us
---	---	--

Reporting Form: Incident / Spill / Sanitary Sewer Overflow (SSO)

The Water Quality Control Division distinguishes between reporting requirements for spills that occur with respect to activities that result in a discharge that is authorized under a CDPS permit and those that are not. Reporting and management of spills that occur with respect to activities resulting in a discharge authorized under a permit should be performed in accordance with the specific requirements of that permit. If the permit does not require a 5-day report, please provide the information below in writing. For non-permitted activities, or in the case of an activity where a permit does not address reporting of or response to a given spill, please submit this written response to the Water Quality Control Division within five (5) working days of the date of the event. If sufficient space is not provided, please attach other sheets. Please send the completed form with signature via fax or email to the Division's Field Services office indicated above. If you have any questions please contact the Division's Field Services Engineer at your earliest convenience. The Field Services County list is available at: <http://www.colorado.gov/cdphe/wqcd> (Contacts, Inspection services contacts, then Field services contacts).

Prior to the five (5) working day deadline, you may request an extension to submit the report if sample analyses justifiably are going to require more time to analyze than the reporting time allows. To request an extension please send an email to the Division's Field Services Engineer for the County that the incident / spill / SSO took place or to the email listed above.

Incident Background Information			
County			
Incident / Spill Number (Division provided) and Spill Date			
Type of Incident / Spill / SSO (check one)	<input type="checkbox"/> Sanitary Sewer Overflow/Reuse	<input type="checkbox"/> Petroleum Product	<input type="checkbox"/> Chemical
	<input type="checkbox"/> WW Treatment Plant Bypass or Upset (through an authorized outfall point)	<input type="checkbox"/> WW Treatment Plant Spill or Overflow (other than outfall)	<input type="checkbox"/> Biosolids
	<input type="checkbox"/> Unplanned potable water release (e.g., water line break)		<input type="checkbox"/> Other
Contact Information			
Potentially Responsible Party (PRP): Contact Name		Potentially Responsible Party (PRP): Company / Agency	
PRP Phone / Fax	Phone: Fax:	PRP email address	
CDPS Permit Number:		CDPS Permittee Name:	
Reported by (if not PRP): Contact Name		Reported by (if not PRP): Company / Agency	
Reported by (if not PRP): Phone / Fax	Phone: Fax:	Reported by (if not PRP): email address	
Incident Information: Please provide the following information.			
A	Incident / spill / SSO source, cause, and event description.		
	Response:		
B	Material released (e.g., untreated wastewater, biosolids, specific chemicals or products) and estimated total quantity (e.g., gallons). Please attach MSDS for any and all chemicals or products involved in spill or release.		
	Response:		
C	Actual or estimated dates and times of the event, including duration and actual date and time spill was fully controlled/stopped. If release is still occurring, the date and time the release is expected to be stopped.		
	Response:		

D	Location of release (e.g., address, lat/long, road name and mile marker).
	Response:
E	Describe measures taken or planned to contain, reduce, and clean up spill or release.
	Response:
F	Steps taken or planned to prevent reoccurrence of the event.
	Response:
Incident Impact to State Waters (As defined in § 25-8-103(19), C.R.S.). <i>Examples of State waters include: perennial streams, intermittent or ephemeral gulches, ditches, ponds, lakes, reservoirs, irrigation canals, wetlands, stormwater conveyances (when they discharge to surface water), and groundwater.</i>	
G	Did flow or materials reach surface waters of the State? If so, please describe the path of flow to State waters and which State water body was impacted (e.g., spill impacted a storm drain which was directly connected to Cherry Creek, Colorado River, etc.). If yes, what quantity of material (e.g., gallons) reached the surface water and what was the resulting impact?
	Response:
H	Were any water quality samples or other samples taken? If so, please describe sampling process and attached results.
	Response:
I	Did flow or materials reach groundwater of the State? If so, please describe the path of flow to State waters and which State water body impacted (e.g., spill soaked into ground and wet soil was not excavated). If yes, what quantity of material (e.g., gallons) reached the ground or groundwater and what was the resulting impact?
	Response:
J	Did the incident include any of the following (check if yes)? If so, please include additional details below.
	<input type="checkbox"/> Toxic Chemical Release <input type="checkbox"/> Fish Kill
	Response:
Incident Impact to Areas or Water Users	
K	Did the incident / spill / SSO impact any areas (e.g., public use areas including parks or swim beaches) or downstream water users (e.g., public water suppliers, irrigation diversions)? Please list impacted areas and/or users, their location, and potential impacts.
	Response:
L	How were the impacted area users (e.g., park patrons) and downstream water users notified (e.g., signs posted, list downstream users contact via phone).
	Response:

I hereby certify that the information presented above is accurate and complete.			
Date	Company	Typed Name and Title	Signature

BMP CONSTRUCTION DETAILS

Description

Vehicle tracking controls provide stabilized construction site access where vehicles exit the site onto paved public roads. An effective vehicle tracking control helps remove sediment (mud or dirt) from vehicles, reducing tracking onto the paved surface.



Photograph VTC-1. A vehicle tracking control pad constructed with properly sized rock reduces off-site sediment tracking.

Appropriate Uses

Implement a stabilized construction entrance or vehicle tracking control where frequent heavy vehicle traffic exits the construction site onto a paved roadway. An effective vehicle tracking control is particularly important during the following conditions:

- Wet weather periods when mud is easily tracked off site.
- During dry weather periods where dust is a concern.
- When poorly drained, clayey soils are present on site.

Although wheel washes are not required in designs of vehicle tracking controls, they may be needed at particularly muddy sites.

Design and Installation

Construct the vehicle tracking control on a level surface. Where feasible, grade the tracking control towards the construction site to reduce off-site runoff. Place signage, as needed, to direct construction vehicles to the designated exit through the vehicle tracking control. There are several different types of stabilized construction entrances including:

VTC-1. Aggregate Vehicle Tracking Control. This is a coarse-aggregate surfaced pad underlain by a geotextile. This is the most common vehicle tracking control, and when properly maintained can be effective at removing sediment from vehicle tires.

VTC-2. Vehicle Tracking Control with Construction Mat or Turf Reinforcement Mat. This type of control may be appropriate for site access at very small construction sites with low traffic volume over vegetated areas. Although this application does not typically remove sediment from vehicles, it helps protect existing vegetation and provides a stabilized entrance.

Vehicle Tracking Control	
Functions	
Erosion Control	Moderate
Sediment Control	Yes
Site/Material Management	Yes

VTC-3. Stabilized Construction Entrance/Exit with Wheel Wash. This is an aggregate pad, similar to VTC-1, but includes equipment for tire washing. The wheel wash equipment may be as simple as hand-held power washing equipment to more advanced proprietary systems. When a wheel wash is provided, it is important to direct wash water to a sediment trap prior to discharge from the site.

Vehicle tracking controls are sometimes installed in combination with a sediment trap to treat runoff.

Maintenance and Removal

Inspect the area for degradation and replace aggregate or material used for a stabilized entrance/exit as needed. If the area becomes clogged and ponds water, remove and dispose of excess sediment or replace material with a fresh layer of aggregate as necessary.

With aggregate vehicle tracking controls, ensure rock and debris from this area do not enter the public right-of-way.

Remove sediment that is tracked onto the public right of way daily or more frequently as needed. Excess sediment in the roadway indicates that the stabilized construction entrance needs maintenance.

Ensure that drainage ditches at the entrance/exit area remain clear.

A stabilized entrance should be removed only when there is no longer the potential for vehicle tracking to occur. This is typically after the site has been stabilized.

When wheel wash equipment is used, be sure that the wash water is discharged to a sediment trap prior to discharge. Also inspect channels conveying the water from the wash area to the sediment trap and stabilize areas that may be eroding.

When a construction entrance/exit is removed, excess sediment from the aggregate should be removed and disposed of appropriately. The entrance should be promptly stabilized with a permanent surface following removal, typically by paving.



Photograph VTC-2. A vehicle tracking control pad with wheel wash facility. Photo courtesy of Tom Gore.

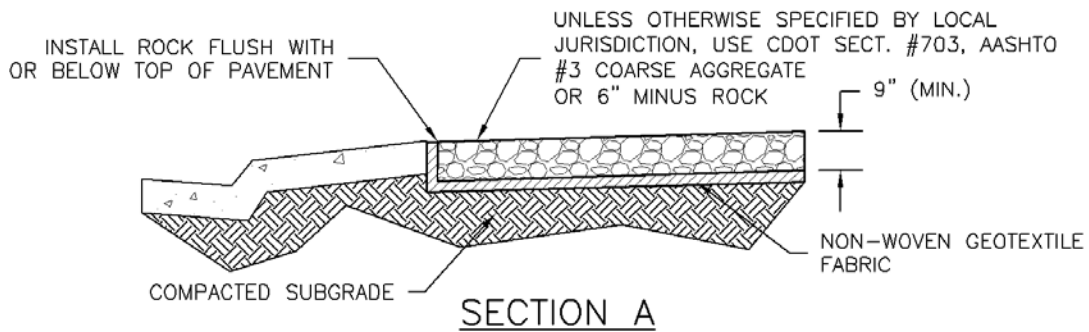
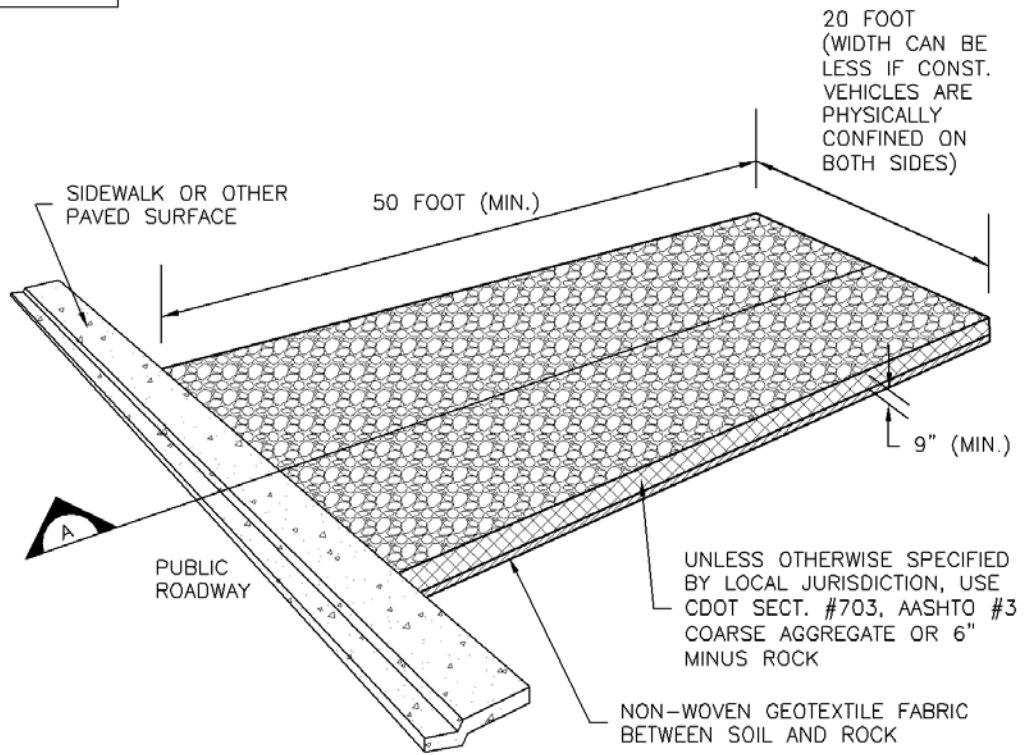
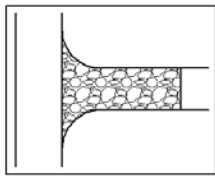

VTC-1. AGGREGATE VEHICLE TRACKING CONTROL

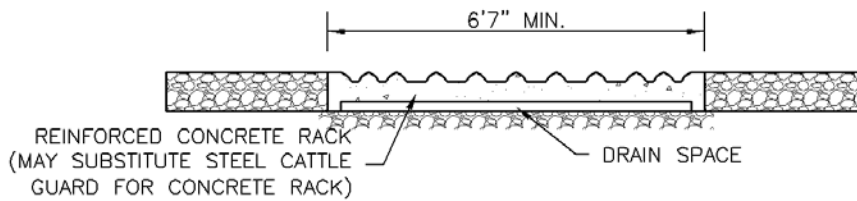
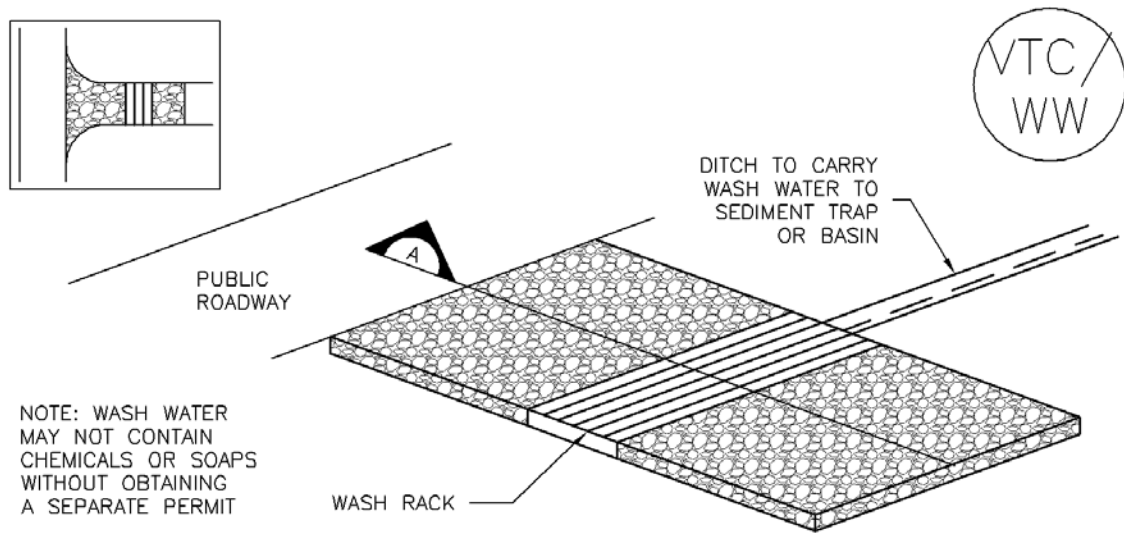

SECTION A

VTC-2. AGGREGATE VEHICLE TRACKING CONTROL WITH WASH RACK

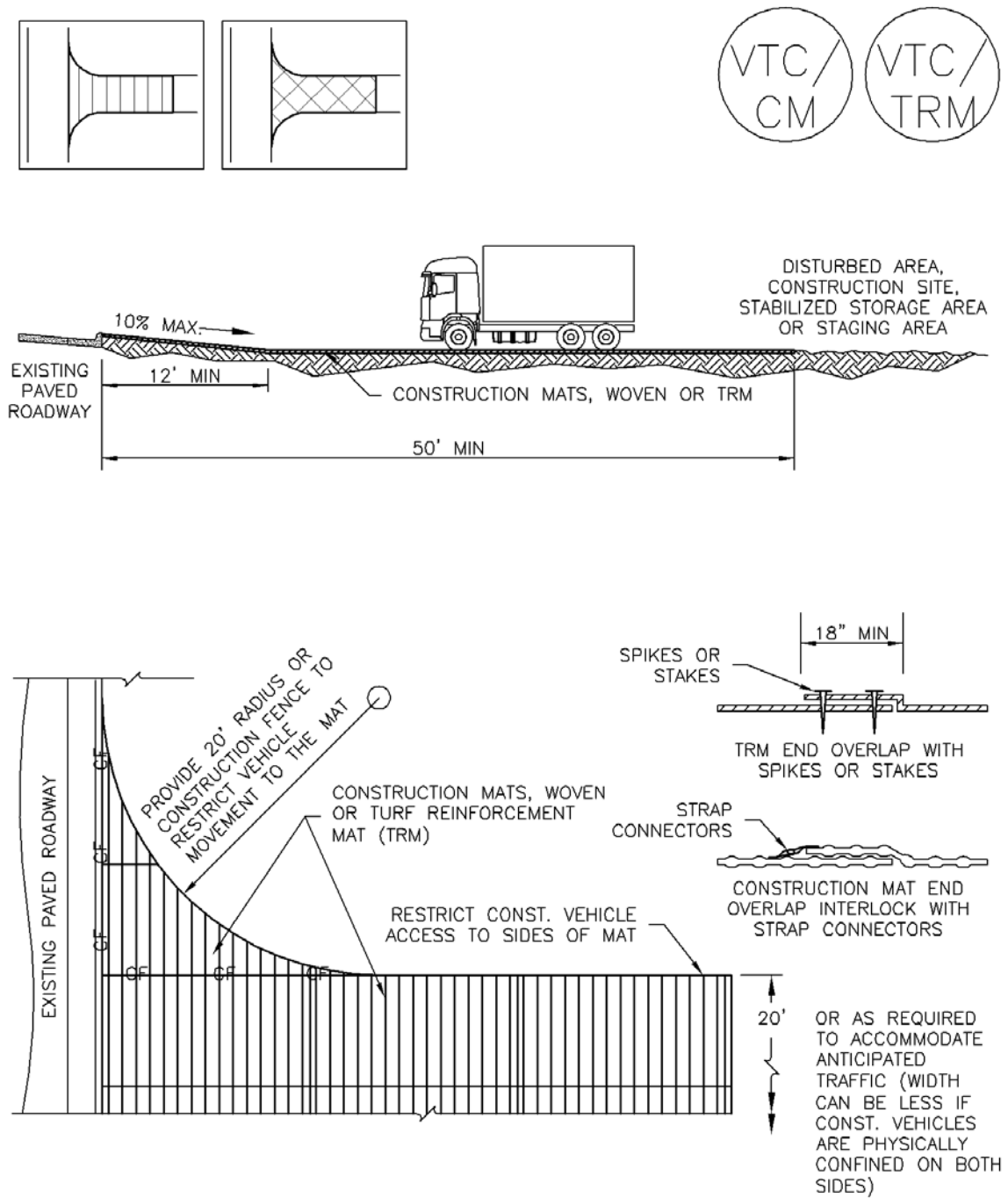

VTC-3. VEHICLE TRACKING CONTROL W/ CONSTRUCTION MAT OR TURF REINFORCEMENT MAT (TRM)

STABILIZED CONSTRUCTION ENTRANCE/EXIT INSTALLATION NOTES

1. SEE PLAN VIEW FOR
 - LOCATION OF CONSTRUCTION ENTRANCE(S)/EXIT(S).
 - TYPE OF CONSTRUCTION ENTRANCE(S)/EXITS(S) (WITH/WITHOUT WHEEL WASH, CONSTRUCTION MAT OR TRM).
2. CONSTRUCTION MAT OR TRM STABILIZED CONSTRUCTION ENTRANCES ARE ONLY TO BE USED ON SHORT DURATION PROJECTS (TYPICALLY RANGING FROM A WEEK TO A MONTH) WHERE THERE WILL BE LIMITED VEHICULAR ACCESS.
3. A STABILIZED CONSTRUCTION ENTRANCE/EXIT SHALL BE LOCATED AT ALL ACCESS POINTS WHERE VEHICLES ACCESS THE CONSTRUCTION SITE FROM PAVED RIGHT-OF-WAYS.
4. STABILIZED CONSTRUCTION ENTRANCE/EXIT SHALL BE INSTALLED PRIOR TO ANY LAND DISTURBING ACTIVITIES.
5. A NON-WOVEN GEOTEXTILE FABRIC SHALL BE PLACED UNDER THE STABILIZED CONSTRUCTION ENTRANCE/EXIT PRIOR TO THE PLACEMENT OF ROCK.
6. UNLESS OTHERWISE SPECIFIED BY LOCAL JURISDICTION, ROCK SHALL CONSIST OF DOT SECT. #703, AASHTO #3 COARSE AGGREGATE OR 6" (MINUS) ROCK.

STABILIZED CONSTRUCTION ENTRANCE/EXIT MAINTENANCE NOTES

1. INSPECT BMPs EACH WORKDAY, AND MAINTAIN THEM IN EFFECTIVE OPERATING CONDITION. MAINTENANCE OF BMPs SHOULD BE PROACTIVE, NOT REACTIVE. INSPECT BMPs AS SOON AS POSSIBLE (AND ALWAYS WITHIN 24 HOURS) FOLLOWING A STORM THAT CAUSES SURFACE EROSION, AND PERFORM NECESSARY MAINTENANCE.
2. FREQUENT OBSERVATIONS AND MAINTENANCE ARE NECESSARY TO MAINTAIN BMPs IN EFFECTIVE OPERATING CONDITION. INSPECTIONS AND CORRECTIVE MEASURES SHOULD BE DOCUMENTED THOROUGHLY.
3. WHERE BMPs HAVE FAILED, REPAIR OR REPLACEMENT SHOULD BE INITIATED UPON DISCOVERY OF THE FAILURE.
4. ROCK SHALL BE REAPPLIED OR REGRADED AS NECESSARY TO THE STABILIZED ENTRANCE/EXIT TO MAINTAIN A CONSISTENT DEPTH.
5. SEDIMENT TRACKED ONTO PAVED ROADS IS TO BE REMOVED THROUGHOUT THE DAY AND AT THE END OF THE DAY BY SHOVELING OR SWEEPING. SEDIMENT MAY NOT BE WASHED DOWN STORM SEWER DRAINS.

NOTE: MANY JURISDICTIONS HAVE BMP DETAILS THAT VARY FROM UDFCD STANDARD DETAILS. CONSULT WITH LOCAL JURISDICTIONS AS TO WHICH DETAIL SHOULD BE USED WHEN DIFFERENCES ARE NOTED.

(DETAILS ADAPTED FROM CITY OF BROOMFIELD, COLORADO, NOT AVAILABLE IN AUTOCAD)

Description

A silt fence is a woven geotextile fabric attached to wooden posts and trenched into the ground. It is designed as a sediment barrier to intercept sheet flow runoff from disturbed areas.

Appropriate Uses

A silt fence can be used where runoff is conveyed from a disturbed area as sheet flow. Silt fence is not designed to receive concentrated flow or to be used as a filter fabric. Typical uses include:

- Down slope of a disturbed area to accept sheet flow.
- Along the perimeter of a receiving water such as a stream, pond or wetland.
- At the perimeter of a construction site.



Photograph SF-1. Silt fence creates a sediment barrier, forcing sheet flow runoff to evaporate or infiltrate.

Design and Installation

Silt fence should be installed along the contour of slopes so that it intercepts sheet flow. The maximum recommended tributary drainage area per 100 lineal feet of silt fence, installed along the contour, is approximately 0.25 acres with a disturbed slope length of up to 150 feet and a tributary slope gradient no steeper than 3:1. Longer and steeper slopes require additional measures. This recommendation only applies to silt fence installed along the contour. Silt fence installed for other uses, such as perimeter control, should be installed in a way that will not produce concentrated flows. For example, a "J-hook" installation may be appropriate to force runoff to pond and evaporate or infiltrate in multiple areas rather than concentrate and cause erosive conditions parallel to the silt fence.

See Detail SF-1 for proper silt fence installation, which involves proper trenching, staking, securing the fabric to the stakes, and backfilling the silt fence. Properly installed silt fence should not be easily pulled out by hand and there should be no gaps between the ground and the fabric.

Silt fence must meet the minimum allowable strength requirements, depth of installation requirement, and other specifications in the design details. Improper installation of silt fence is a common reason for silt fence failure; however, when properly installed and used for the appropriate purposes, it can be highly effective.

Silt Fence	
Functions	
Erosion Control	No
Sediment Control	Yes
Site/Material Management	No

Maintenance and Removal

Inspection of silt fence includes observing the material for tears or holes and checking for slumping fence and undercut areas bypassing flows. Repair of silt fence typically involves replacing the damaged section with a new section. Sediment accumulated behind silt fence should be removed, as needed to maintain BMP effectiveness, typically before it reaches a depth of 6 inches.

Silt fence may be removed when the upstream area has reached final stabilization.



Photograph SF-2. When silt fence is not installed along the contour, a "J-hook" installation may be appropriate to ensure that the BMP does not create concentrated flow parallel to the silt fence. Photo courtesy of Tom Gore.

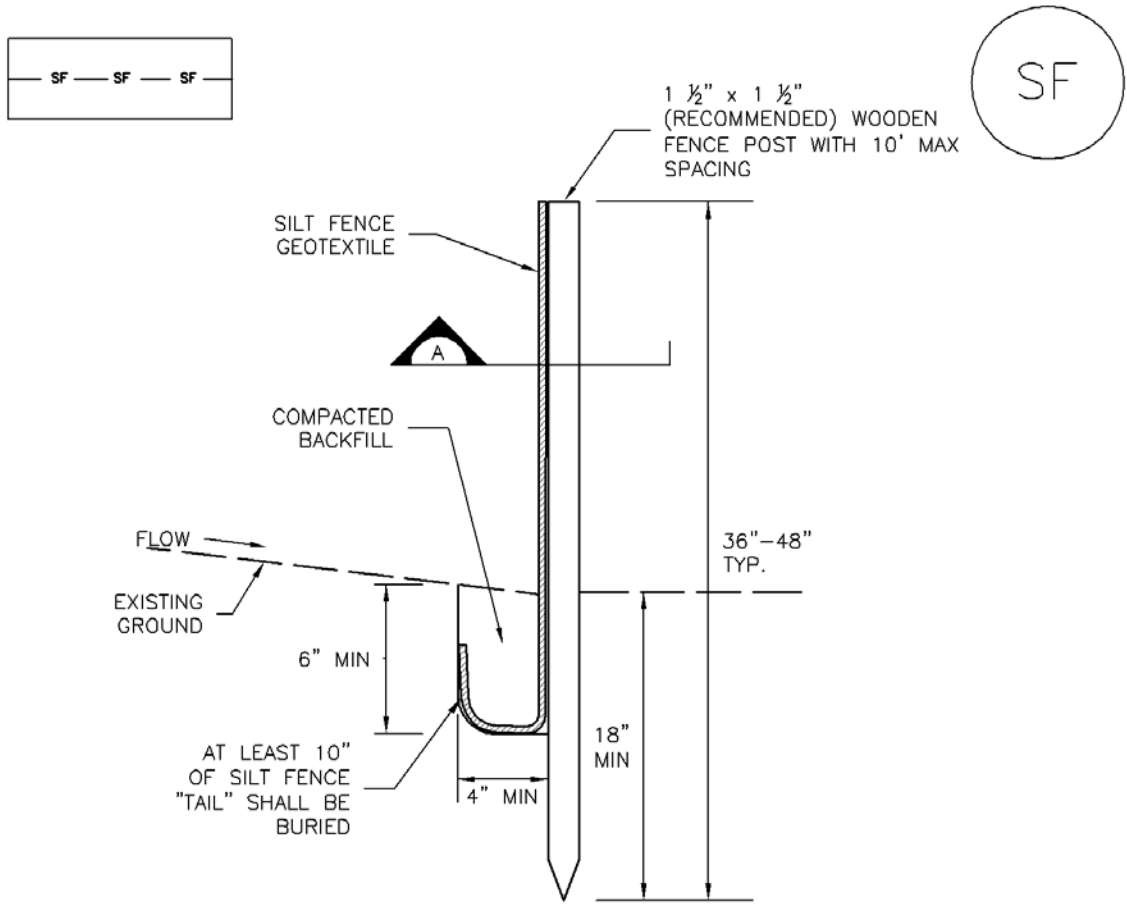

SILT FENCE

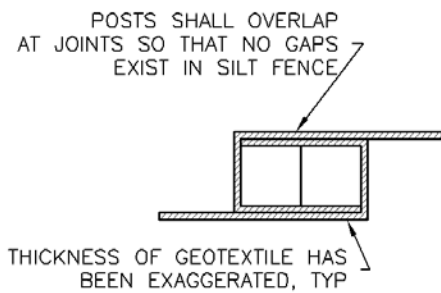
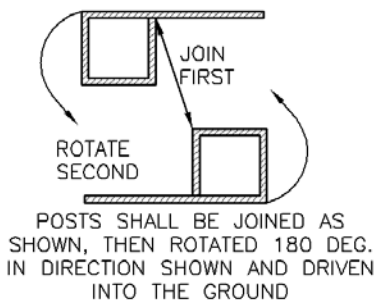

SECTION A

SF-1. SILT FENCE

SILT FENCE INSTALLATION NOTES

1. SILT FENCE MUST BE PLACED AWAY FROM THE TOE OF THE SLOPE TO ALLOW FOR WATER PONDING. SILT FENCE AT THE TOE OF A SLOPE SHOULD BE INSTALLED IN A FLAT LOCATION AT LEAST SEVERAL FEET (2-5 FT) FROM THE TOE OF THE SLOPE TO ALLOW ROOM FOR PONDING AND DEPOSITION.
2. A UNIFORM 6" X 4" ANCHOR TRENCH SHALL BE EXCAVATED USING TRENCHER OR SILT FENCE INSTALLATION DEVICE. NO ROAD GRADERS, BACKHOES, OR SIMILAR EQUIPMENT SHALL BE USED.
3. COMPACT ANCHOR TRENCH BY HAND WITH A "JUMPING JACK" OR BY WHEEL ROLLING. COMPACTION SHALL BE SUCH THAT SILT FENCE RESISTS BEING PULLED OUT OF ANCHOR TRENCH BY HAND.
4. SILT FENCE SHALL BE PULLED TIGHT AS IT IS ANCHORED TO THE STAKES. THERE SHOULD BE NO NOTICEABLE SAG BETWEEN STAKES AFTER IT HAS BEEN ANCHORED TO THE STAKES.
5. SILT FENCE FABRIC SHALL BE ANCHORED TO THE STAKES USING 1" HEAVY DUTY STAPLES OR NAILS WITH 1" HEADS. STAPLES AND NAILS SHOULD BE PLACED 3" ALONG THE FABRIC DOWN THE STAKE.
6. AT THE END OF A RUN OF SILT FENCE ALONG A CONTOUR, THE SILT FENCE SHOULD BE TURNED PERPENDICULAR TO THE CONTOUR TO CREATE A "J-HOOK." THE "J-HOOK" EXTENDING PERPENDICULAR TO THE CONTOUR SHOULD BE OF SUFFICIENT LENGTH TO KEEP RUNOFF FROM FLOWING AROUND THE END OF THE SILT FENCE (TYPICALLY 10' - 20').
7. SILT FENCE SHALL BE INSTALLED PRIOR TO ANY LAND DISTURBING ACTIVITIES.

SILT FENCE MAINTENANCE NOTES

1. INSPECT BMPs EACH WORKDAY, AND MAINTAIN THEM IN EFFECTIVE OPERATING CONDITION. MAINTENANCE OF BMPs SHOULD BE PROACTIVE, NOT REACTIVE. INSPECT BMPs AS SOON AS POSSIBLE (AND ALWAYS WITHIN 24 HOURS) FOLLOWING A STORM THAT CAUSES SURFACE EROSION, AND PERFORM NECESSARY MAINTENANCE.
2. FREQUENT OBSERVATIONS AND MAINTENANCE ARE NECESSARY TO MAINTAIN BMPs IN EFFECTIVE OPERATING CONDITION. INSPECTIONS AND CORRECTIVE MEASURES SHOULD BE DOCUMENTED THOROUGHLY.
3. WHERE BMPs HAVE FAILED, REPAIR OR REPLACEMENT SHOULD BE INITIATED UPON DISCOVERY OF THE FAILURE.
4. SEDIMENT ACCUMULATED UPSTREAM OF THE SILT FENCE SHALL BE REMOVED AS NEEDED TO MAINTAIN THE FUNCTIONALITY OF THE BMP, TYPICALLY WHEN DEPTH OF ACCUMULATED SEDIMENTS IS APPROXIMATELY 6".
5. REPAIR OR REPLACE SILT FENCE WHEN THERE ARE SIGNS OF WEAR, SUCH AS SAGGING, TEARING, OR COLLAPSE.
6. SILT FENCE IS TO REMAIN IN PLACE UNTIL THE UPSTREAM DISTURBED AREA IS STABILIZED AND APPROVED BY THE LOCAL JURISDICTION, OR IS REPLACED BY AN EQUIVALENT PERIMETER SEDIMENT CONTROL BMP.
7. WHEN SILT FENCE IS REMOVED, ALL DISTURBED AREAS SHALL BE COVERED WITH TOPSOIL, SEEDED AND MULCHED OR OTHERWISE STABILIZED AS APPROVED BY LOCAL JURISDICTION.

(DETAIL ADAPTED FROM TOWN OF PARKER, COLORADO AND CITY OF AURORA, NOT AVAILABLE IN AUTOCAD)

NOTE: MANY JURISDICTIONS HAVE BMP DETAILS THAT VARY FROM UDFCD STANDARD DETAILS. CONSULT WITH LOCAL JURISDICTIONS AS TO WHICH DETAIL SHOULD BE USED WHEN DIFFERENCES ARE NOTED.

Description

Concrete waste management involves designating and properly managing a specific area of the construction site as a concrete washout area. A concrete washout area can be created using one of several approaches designed to receive wash water from washing of tools and concrete mixer chutes, liquid concrete waste from dump trucks, mobile batch mixers, or pump trucks. Three basic approaches are available: excavation of a pit in the ground, use of an above ground storage area, or use of prefabricated haul-away concrete washout containers. Surface discharges of concrete washout water from construction sites are prohibited.



Photograph CWA-1. Example of concrete washout area. Note gravel tracking pad for access and sign.

Appropriate Uses

Concrete washout areas must be designated on all sites that will generate concrete wash water or liquid concrete waste from onsite concrete mixing or concrete delivery.

Because pH is a pollutant of concern for washout activities, when unlined pits are used for concrete washout, the soil must have adequate buffering capacity to result in protection of state groundwater standards; otherwise, a liner/containment must be used. The following management practices are recommended to prevent an impact from unlined pits to groundwater:

- The use of the washout site should be temporary (less than 1 year), and
- The washout site should be not be located in an area where shallow groundwater may be present, such as near natural drainages, springs, or wetlands.

Design and Installation

Concrete washout activities must be conducted in a manner that does not contribute pollutants to surface waters or stormwater runoff. Concrete washout areas may be lined or unlined excavated pits in the ground, commercially manufactured prefabricated washout containers, or aboveground holding areas constructed of berms, sandbags or straw bales with a plastic liner.

Although unlined washout areas may be used, lined pits may be required to protect groundwater under certain conditions.

Do not locate an unlined washout area within 400 feet of any natural drainage pathway or waterbody or within 1,000 feet of any wells or drinking water sources. Even for lined concrete washouts, it is advisable to locate the facility away from waterbodies and drainage paths. If site constraints make these

Concrete Washout Area	
Functions	
Erosion Control	No
Sediment Control	No
Site/Material Management	Yes

setbacks infeasible or if highly permeable soils exist in the area, then the pit must be installed with an impermeable liner (16 mil minimum thickness) or surface storage alternatives using prefabricated concrete washout devices or a lined aboveground storage area should be used.

Design details with notes are provided in Detail CWA-1 for pits and CWA-2 for aboveground storage areas. Pre-fabricated concrete washout container information can be obtained from vendors.

Maintenance and Removal

A key consideration for concrete washout areas is to ensure that adequate signage is in place identifying the location of the washout area. Part of inspecting and maintaining washout areas is ensuring that adequate signage is provided and in good repair and that the washout area is being used, as opposed to washout in non-designated areas of the site.

Remove concrete waste in the washout area, as needed to maintain BMP function (typically when filled to about two-thirds of its capacity). Collect concrete waste and deliver offsite to a designated disposal location.

Upon termination of use of the washout site, accumulated solid waste, including concrete waste and any contaminated soils, must be removed from the site to prevent on-site disposal of solid waste. If the wash water is allowed to evaporate and the concrete hardens, it may be recycled.



Photograph CWA-2. Prefabricated concrete washout. Photo courtesy of CDOT.



Photograph CWA-3. Earthen concrete washout. Photo courtesy of CDOT.

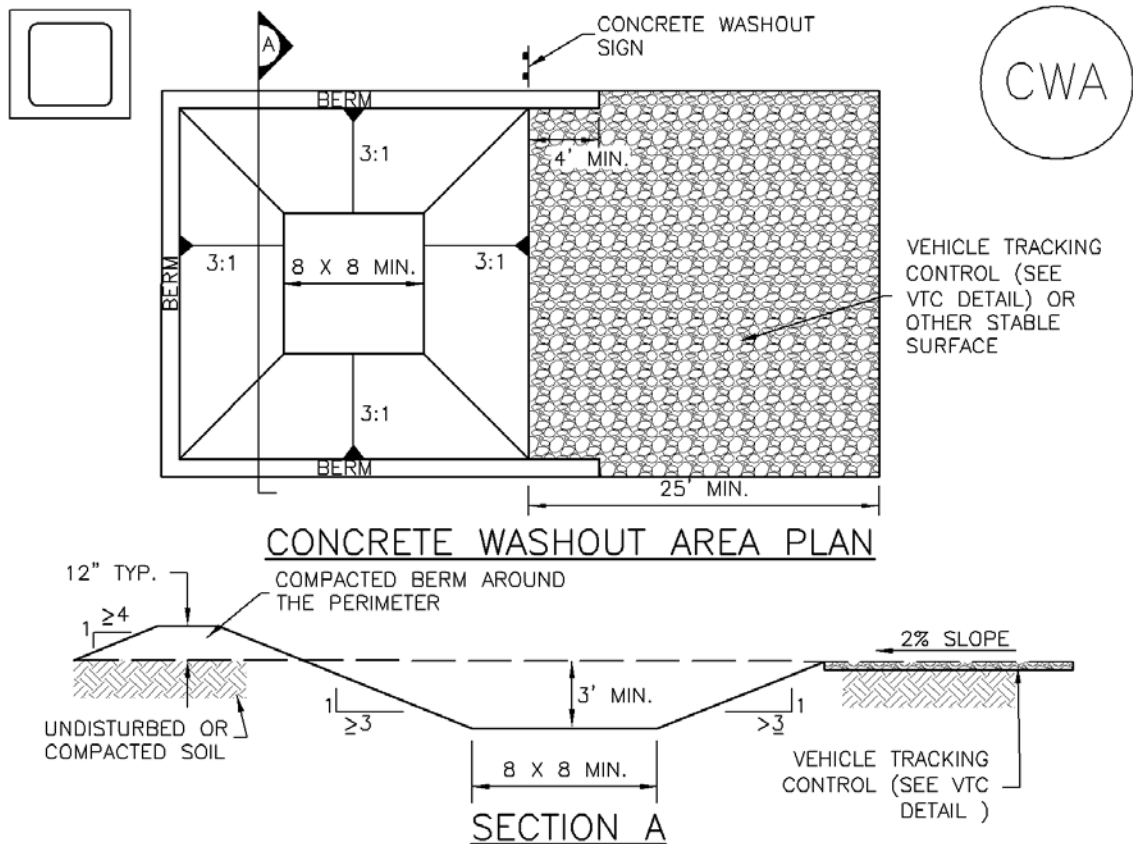

CWA-1. CONCRETE WASHOUT AREA

CWA INSTALLATION NOTES

1. SEE PLAN VIEW FOR:
-CWA INSTALLATION LOCATION.
2. DO NOT LOCATE AN UNLINED CWA WITHIN 400' OF ANY NATURAL DRAINAGE PATHWAY OR WATERBODY. DO NOT LOCATE WITHIN 1,000' OF ANY WELLS OR DRINKING WATER SOURCES. IF SITE CONSTRAINTS MAKE THIS INFEASIBLE, OR IF HIGHLY PERMEABLE SOILS EXIST ON SITE, THE CWA MUST BE INSTALLED WITH AN IMPERMEABLE LINER (16 MIL MIN. THICKNESS) OR SURFACE STORAGE ALTERNATIVES USING PREFABRICATED CONCRETE WASHOUT DEVICES OR A LINED ABOVE GROUND STORAGE ARE SHOULD BE USED.
3. THE CWA SHALL BE INSTALLED PRIOR TO CONCRETE PLACEMENT ON SITE.
4. CWA SHALL INCLUDE A FLAT SUBSURFACE PIT THAT IS AT LEAST 8' BY 8' SLOPES LEADING OUT OF THE SUBSURFACE PIT SHALL BE 3:1 OR FLATTER. THE PIT SHALL BE AT LEAST 3' DEEP.
5. BERM SURROUNDING SIDES AND BACK OF THE CWA SHALL HAVE MINIMUM HEIGHT OF 1'.
6. VEHICLE TRACKING PAD SHALL BE SLOPED 2% TOWARDS THE CWA.
7. SIGNS SHALL BE PLACED AT THE CONSTRUCTION ENTRANCE, AT THE CWA, AND ELSEWHERE AS NECESSARY TO CLEARLY INDICATE THE LOCATION OF THE CWA TO OPERATORS OF CONCRETE TRUCKS AND PUMP RIGS.
8. USE EXCAVATED MATERIAL FOR PERIMETER BERM CONSTRUCTION.

CWA MAINTENANCE NOTES

1. INSPECT BMPs EACH WORKDAY, AND MAINTAIN THEM IN EFFECTIVE OPERATING CONDITION. MAINTENANCE OF BMPs SHOULD BE PROACTIVE, NOT REACTIVE. INSPECT BMPs AS SOON AS POSSIBLE (AND ALWAYS WITHIN 24 HOURS) FOLLOWING A STORM THAT CAUSES SURFACE EROSION, AND PERFORM NECESSARY MAINTENANCE.

2. FREQUENT OBSERVATIONS AND MAINTENANCE ARE NECESSARY TO MAINTAIN BMPs IN EFFECTIVE OPERATING CONDITION. INSPECTIONS AND CORRECTIVE MEASURES SHOULD BE DOCUMENTED THOROUGHLY.

3. WHERE BMPs HAVE FAILED, REPAIR OR REPLACEMENT SHOULD BE INITIATED UPON DISCOVERY OF THE FAILURE.

4. THE CWA SHALL BE REPAIRED, CLEANED, OR ENLARGED AS NECESSARY TO MAINTAIN CAPACITY FOR CONCRETE WASTE. CONCRETE MATERIALS, ACCUMULATED IN PIT, SHALL BE REMOVED ONCE THE MATERIALS HAVE REACHED A DEPTH OF 2'.

5. CONCRETE WASHOUT WATER, WASTED PIECES OF CONCRETE AND ALL OTHER DEBRIS IN THE SUBSURFACE PIT SHALL BE TRANSPORTED FROM THE JOB SITE IN A WATER-TIGHT CONTAINER AND DISPOSED OF PROPERLY.

6. THE CWA SHALL REMAIN IN PLACE UNTIL ALL CONCRETE FOR THE PROJECT IS PLACED.

7. WHEN THE CWA IS REMOVED, COVER THE DISTURBED AREA WITH TOP SOIL, SEED AND MULCH OR OTHERWISE STABILIZED IN A MANNER APPROVED BY THE LOCAL JURISDICTION.

(DETAIL ADAPTED FROM DOUGLAS COUNTY, COLORADO AND THE CITY OF PARKER, COLORADO, NOT AVAILABLE IN AUTOCAD).

NOTE: MANY JURISDICTIONS HAVE BMP DETAILS THAT VARY FROM UDFCD STANDARD DETAILS. CONSULT WITH LOCAL JURISDICTIONS AS TO WHICH DETAIL SHOULD BE USED WHEN DIFFERENCES ARE NOTED.

Description

A sand filter is a filtering or infiltrating BMP that consists of a surcharge zone underlain by a sand bed with an underdrain system (when necessary). During a storm, accumulated runoff collects in the surcharge zone and gradually infiltrates into the underlying sand bed, filling the void spaces of the sand. The underdrain gradually dewateres the sand bed and discharges the runoff to a nearby channel, swale, or storm sewer. It is similar to a BMP designed for bioretention in that it utilizes filtering, but differs in that it is not specifically designed for vegetative growth. For this reason, it can have a greater depth and be designed for a larger contributing area. A sand filter is also similar to an extended detention basin (EDB) in that it is a dry basin, which can be easily designed to include the flood control volume above the WQCV or EURV. However, a sand filter does not require a forebay or micropool because the solids that would be deposited in these components in an EDB will be retained on the surface of the sand bed in a sand filter. Sand filters can be vegetated with species that will tolerate both wet and dry conditions and occasional inundation. The rain garden growing media is recommended for sand filters where vegetation is desired. Sand filters can also be placed in a vault. Underground sand filters have additional requirements. See Fact Sheet T-11 for additional discussion on underground BMPs.



Photograph SF-1. The vegetation on the surface of the filter and the shallow design depth of this sand filter, help the BMP blend into its surroundings. Photo courtesy of Fred Bromberger.

Site Selection

Sand filters require a stable watershed. When the watershed includes phased construction, sparsely vegetated areas, or steep slopes in sandy soils, consider another BMP or provide pretreatment before runoff from these areas reach the rain garden.

When sand filters (and other BMPs used for infiltration) are located adjacent to buildings or pavement areas, protective measures should be implemented to avoid adverse impacts to these structures. Oversaturated subgrade soil underlying a structure can cause the structure to settle or result in moisture-related problems. Wetting of expansive soils or bedrock can cause swelling, resulting in structural movements. A geotechnical engineer should evaluate the potential impact of the BMP on

Sand/Media Filter	
Functions	
LID/Volume Red.	Yes
WQCV Capture	Yes
WQCV+Flood Control	Yes
Fact Sheet Includes EURV Guidance	No
Typical Effectiveness for Targeted Pollutants³	
Sediment/Solids	Very Good ¹
Nutrients	Good
Total Metals	Good
Bacteria	Moderate
Other Considerations	
Life-cycle Costs ⁴	Moderate
¹ Not recommended for watersheds with high sediment yields (unless pretreatment is provided). ³ Based primarily on data from the International Stormwater BMP Database (www.bmpdatabase.org). ⁴ Based primarily on BMP-REALCOST available at www.udfcd.org . Analysis based on a single installation (not based on the maximum recommended watershed tributary to each BMP).	

adjacent structures based on an evaluation of the subgrade soil, groundwater, and bedrock conditions at the site. Additional minimum requirements include:

- In locations where subgrade soils do not allow infiltration, the filter layer should be underlain by an underdrain system.
- Where infiltration can adversely impact adjacent structures, the filter layer should be underlain by an underdrain system designed to divert water away from the structure.
- In locations where potentially expansive soils or bedrock exist, placement of a sand filter adjacent to structures and pavement should only be considered if the BMP includes an underdrain designed to divert water away from the structure, and is lined with an impermeable geomembrane liner designed to restrict seepage.

Designing for Maintenance

Recommended maintenance practices for all BMPs are provided in Chapter 6 of this manual. During design the following should be considered to ensure ease of maintenance over the long-term:

- Do not put a filter sock on the underdrain. This is not necessary and can cause the BMP to clog.
- Install cleanouts. Cleanouts can be used for inspection (by camera) immediately following construction to ensure that the underdrain pipe was not crushed during construction. They can also be used to for ongoing maintenance practices. Consider locating cleanouts in the side slopes of the basin and above the depth of ponding.
- Provide vegetated side slopes to pre-treat runoff by filtering (straining). This will reduce the frequency of maintenance.

Design Procedure and Criteria

The following steps outline the design procedure and criteria for a sand filter.

1. **Basin Storage Volume:** Provide a storage volume above the sand bed of the basin equal to the WQCV based on a 24-hour drain time. Although the BMP will be designed to drain in 12 hours, sizing the basin for a longer drain time will ensure containment of the WQCV as infiltration through the filter layer slows over time.

Benefits

- Filtering BMPs provide effective water quality enhancement including phosphorus removal.

Limitations

- This BMP may clog and require maintenance if a moderate to high level of silts and clays are allowed to flow into the facility.
- This BMP should not be located within 10 feet of a building foundation without an impermeable membrane. See *Bioretention* (BMP Fact Sheet T-3) of this manual for additional information.
- The sand filter should not be put into operation while construction or major landscaping activities are taking place in the watershed.

- Determine the imperviousness of the tributary area (or effective imperviousness where LID techniques are implemented). Determine the required WQCV (watershed inches of runoff) using Figure 3-2 in Chapter 3 of this manual. The volume should be based on a drain time of 24 hours.
- Calculate the design volume as follows:

$$V = \left[\frac{WQCV}{12} \right] A \tag{Equation SF-1}$$

Where:

V = design volume (ft³)

A = watershed area tributary to the sand filter (ft²)

2. **Basin Geometry:** Use equation SF-2 to calculate the minimum filter area, which is the flat surface of the sand filter. Sediment will reside on the filter area of the sand filter. Therefore, if the filter area is too small, the filter may clog prematurely. If this is of particular concern, increasing the filter area will decrease the frequency of maintenance. The following equation provides the minimum filter area allowing for some of the volume to be stored beyond the area of the filter. **Note that the total volume must also equal or exceed the design volume.**

The side slopes of the basin should be stable and maintainable. For vegetated side slopes, a 4:1 (horizontal: vertical) minimum slope is recommended. Use vertical walls where side slopes are steeper than 3:1

$$A = \frac{2V}{9} \tag{Equation SF-2}$$

Where:

A = minimum filter area (flat surface area) (ft²)

V = design volume (ft³)

3. **Filter Material:** Provide, at a minimum, an 18-inch layer of CDOT Class C filter material (see Table SF-1). Maintain a flat surface on the top of the sand bed.

Table SF-1. Gradation Specifications for CDOT Class C Filter Material
(Source: CDOT Table 703-7)

Sieve Size	Mass Percent Passing Square Mesh Sieves
19.0 mm (3/4")	100
4.75 mm (No. 4)	60 – 100
300 μm (No. 50)	10 – 30
150 μm (No. 100)	0 – 10
75 μm (No. 200)	0 - 3

4. **Underdrain System:** Underdrains are typically required for sand filters and should be provided if infiltration tests show rates slower than 2 times that required to drain the WQCV over 12 hours, or where required to divert water away from structures as determined by a professional engineer. Percolation tests should be performed or supervised by a licensed professional engineer and conducted at a minimum depth equal to the bottom of the sand filter. Additionally, underdrains are required where impermeable membranes are used. There are three basic types of sand filters:
- **No-Infiltration:** This section includes an underdrain and an impermeable liner that does not allow for infiltration of stormwater into the subgrade soils. It is appropriate to use a no-infiltration system when any of the following is true:
 - Land use or activities could contaminate groundwater when stormwater is allowed to infiltrate, or
 - The BMP is located over potentially expansive soils or bedrock or is adjacent (within 10 feet) to structures.
 - **Partial Infiltration:** This section does not include an impermeable liner, allowing for some infiltration. Stormwater that does not infiltrate will be collected and removed by an underdrain system.
 - **Full Infiltration:** This section is designed to infiltrate all of the water stored into the subgrade below. UDFCD recommends a minimum infiltration rate of 2 times the rate needed to drain the WQCV over 12 hours.

When using an underdrain system, provide a control orifice sized to drain the design volume in approximately 12 hours or more (see Equation SF-3). Use a minimum orifice size of 3/8 inch to avoid clogging. This will provide detention and slow release of the WQCV to offset hydromodification. Provide cleanouts to allow inspection of the drainpipe system during and after construction to ensure that the pipe was not crushed or disconnected during construction and to allow for maintenance of the underdrain. Space underdrain pipes a maximum of 20 feet on-center.

$$D_{12 \text{ hour drain time}} = \sqrt{\frac{V}{1414 y^{0.41}}} \quad \text{Equation SF-3}$$

Where:

D = orifice diameter (in)

y = distance from the lowest elevation of the storage volume (ft) (i.e., surface of the filter) to the center of the orifice

V = volume to drain in 12 hours (WQCV) (ft³)

In previous versions of this manual, UDFCD recommended that the underdrain be placed in an aggregate layer and that a geotextile (separator fabric) be placed between this aggregate and the growing medium. This version of the manual replaces that section with materials that, when used together, eliminate the need for a separator fabric.

The underdrain system should be placed below the 18-inch (minimum) filter layer. The underdrain system should be placed within an 5-inch-thick section of CDOT Class C filter material meeting the gradation in Table SF-1. Areas of the underdrain layer may be deeper due to the slope of the underdrain. If no underdrain is required, the minimum section can be reduced to the 18-inch filter layer. Use slotted pipe that meets the slot dimensions provided in Table SF-2.

Table SF-2. Dimensions for Slotted Pipe

Pipe Size	Slot Length ¹	Maximum Slot Width	Slot Centers ¹	Open Area ¹ (per foot)
4"	1-1/16"	0.032"	0.413"	1.90 in ²
6"	1-3/8"	0.032"	0.516"	1.98 in ²

¹ Some variation in these values is acceptable and is expected from various pipe manufacturers. Be aware that both increased slot length and decreased slot centers will be beneficial to hydraulics but detrimental to the structure of the pipe.

Table SF-3. Physical Requirements for Separator Fabric¹

Property	Class B		Test Method
	Elongation < 50% ²	Elongation > 50% ²	
Grab Strength, N (lbs)	800 (180)	510 (115)	ASTM D 4632
Puncture Resistance, N (lbs)	310 (70)	180 (40)	ASTM D 4833
Trapezoidal Tear Strength, N (lbs)	310 (70)	180 (40)	ASTM D 4533
Apparent Opening Size, mm (US Sieve Size)	AOS < 0.3mm (US Sieve Size No. 50)		ASTM D 4751
Permittivity, sec ⁻¹	0.02 default value, must also be greater than that of soil		ASTM D 4491
Permeability, cm/sec	k fabric > k soil for all classes		ASTM D 4491
Ultraviolet Degradation at 500 hours	50% strength retained for all classes		ASTM D 4355

¹ Strength values are in the weaker principle direction

² As measured in accordance with ASTM D 4632

5. **Impermeable Geomembrane Liner and Geotextile Separator Fabric:** For no-infiltration sections, install a minimum 30-mil thick PVC geomembrane liner, per Table SF-4, on the bottom and sides of the basin, extending up at least to the top of the underdrain layer. Provide at least 9 inches (12 inches if possible) of cover over the membrane where it is attached to the wall to protect the membrane from UV deterioration. The geomembrane should be field-seamed using a dual track welder, which allows for non-destructive testing of almost all field seams. A small amount of single track and/or adhesive seaming should be allowed in limited areas to seam around pipe perforations, to patch seams removed for destructive seam testing, and for limited repairs. The liner should be installed with slack to prevent tearing due to backfill, compaction, and settling. Place CDOT Class B geotextile separator fabric above the geomembrane to protect it from being punctured during the placement of the filter material above the liner. If the subgrade contains angular rocks or other material that could puncture the geomembrane, smooth-roll the surface to create a suitable surface. If smooth-rolling the surface does not provide a suitable surface, also place the separator fabric between the geomembrane and the underlying subgrade. This should only be done when necessary because fabric placed under the geomembrane can increase seepage losses through pinholes or other geomembrane defects. Connect the geomembrane to perimeter concrete walls around the basin perimeter, creating a watertight seal between the geomembrane and the walls using a continuous batten bar and anchor connection (see Figure SF-3). Where the need for the impermeable membrane is not as critical, the membrane can be attached with a nitrile-based vinyl adhesive. Use watertight PVC boots for underdrain pipe penetrations through the liner (see Figure SF-2).

Table SF-4. Physical Requirements for Geomembrane

Property	Thickness 0.76 mm (30 mil)	Test Method
Thickness, % Tolerance	±5	ASTM D 1593
Tensile Strength, kN/m (lbs/in) width	12.25 (70)	ASTM D 882, Method B
Modulus at 100% Elongation, kN/m (lbs/in)	5.25 (30)	ASTM D 882, Method B
Ultimate Elongation, %	350	ASTM D 882, Method A
Tear Resistance, N (lbs)	38 (8.5)	ASTM D 1004
Low Temperature Impact, °C (°F)	-29 (-20)	ASTM D 1790
Volatile loss, % max.	0.7	ASTM D 1203, Method A
Pinholes, No. Per 8 m ² (No. per 10 sq. yds.) max.	1	N/A
Bonded Seam Strength, % of tensile strength	80	N/A

6. **Inlet Works:** Provide energy dissipation at all inlet points into the sand filter. Use an impact basin for pipes and a baffle chute or grouted sloping boulder drop if a channel or swale is used, or install a Type VL or L riprap basin underlain with geotextile fabric at the inlet (see Figure SF-1). Fill all rock voids with the filter material specified in Table SF-1.

- 7. Outlet Works:** Slope the underdrain into a larger outlet structure. As discussed in Step 4, use an orifice plate to drain the WQCV over approximately 12 hours. Flows exceeding the WQCV should also drain into the outlet structure. Additional flow restrictions may be incorporated to provide Full Spectrum Detention, as discussed in the *Storage* chapter of Volume 2, or peak reduction for other specific storm events.

For Full Spectrum Detention, perform reservoir routing calculations to design the outlet structure. The *UD-Detention* workbook, available at www.udfcd.org, can be used for this purpose. The design could include a second orifice located at the WQCV elevation or could include a downstream point of control designed to drain the full excess urban runoff volume (EURV) in approximately 72 hours.

Construction Considerations

Proper construction of sand filters involves careful attention to material specifications and construction details. For a successful project, do the following:

- Protect area from excessive sediment loading during construction. The portion of the site draining to the sand filter must be stabilized before allowing flow into the sand filter.
- When using an impermeable liner, ensure enough slack in the liner to allow for backfill, compaction, and settling without tearing the liner.

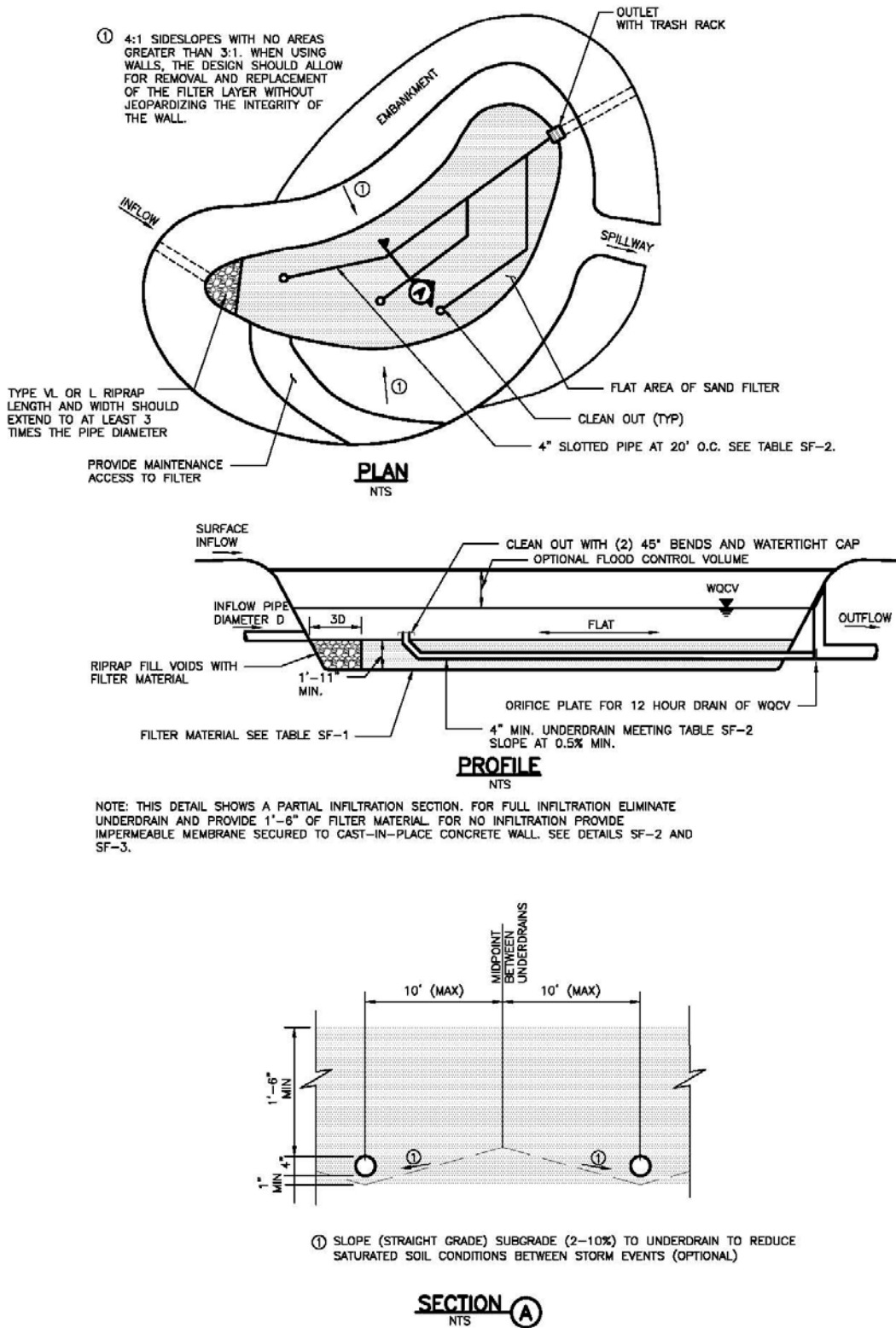

Figure SF-1. Sand Filter Plan and Sections

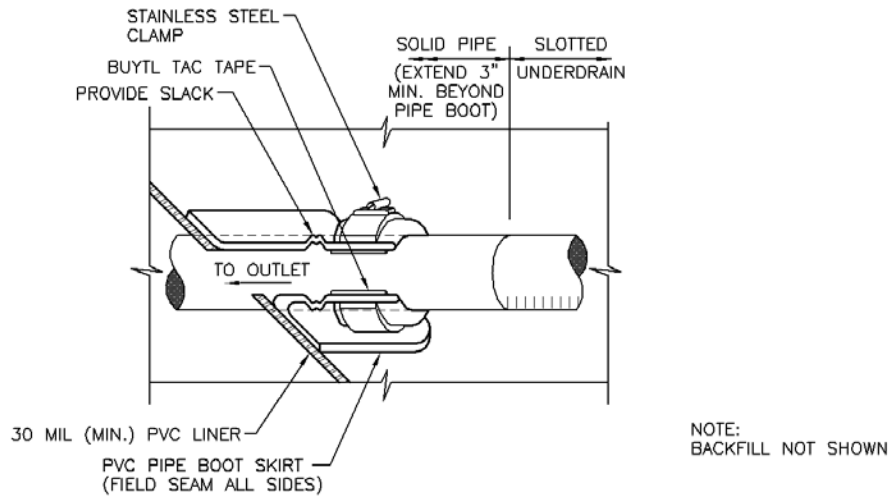

Figure SF-2. Geomembrane Liner/Underdrain Penetration Detail

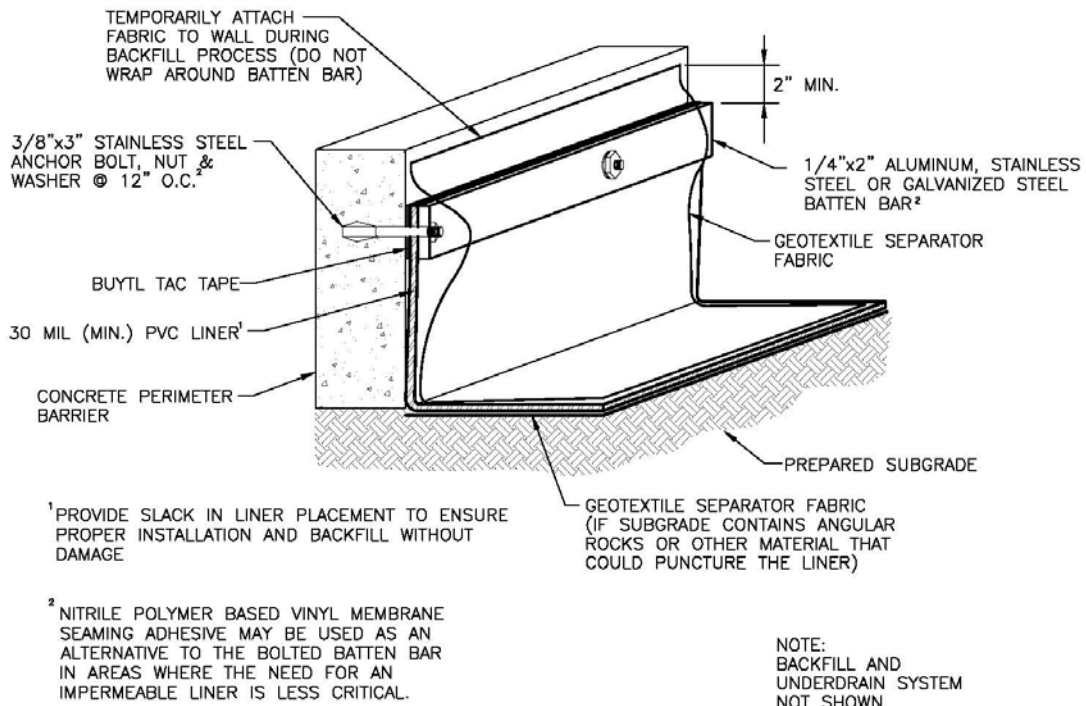

Figure SF-3. Geomembrane Liner/Concrete Connection Detail

Description

A sediment basin is a temporary pond built on a construction site to capture eroded or disturbed soil transported in storm runoff prior to discharge from the site. Sediment basins are designed to capture site runoff and slowly release it to allow time for settling of sediment prior to discharge. Sediment basins are often constructed in locations that will later be modified to serve as post-construction stormwater basins.



Photograph SB-1. Sediment basin at the toe of a slope. Photo courtesy of WWE.

Appropriate Uses

Most large construction sites (typically greater than 2 acres) will require one or more sediment basins for effective management of construction site runoff. On linear construction projects, sediment basins may be impractical; instead, sediment traps or other combinations of BMPs may be more appropriate.

Sediment basins should not be used as stand-alone sediment controls. Erosion and other sediment controls should also be implemented upstream.

When feasible, the sediment basin should be installed in the same location where a permanent post-construction detention pond will be located.

Design and Installation

The design procedure for a sediment basin includes these steps:

- **Basin Storage Volume:** Provide a storage volume of at least 3,600 cubic feet per acre of drainage area. To the extent practical, undisturbed and/or off-site areas should be diverted around sediment basins to prevent “clean” runoff from mixing with runoff from disturbed areas. For undisturbed areas (both on-site and off-site) that cannot be diverted around the sediment basin, provide a minimum of 500 ft³/acre of storage for undeveloped (but stable) off-site areas in addition to the 3,600 ft³/acre for disturbed areas. For stable, developed areas that cannot be diverted around the sediment basin, storage volume requirements are summarized in Table SB-1.
- **Basin Geometry:** Design basin with a minimum length-to-width ratio of 2:1 (L:W). If this cannot be achieved because of site space constraints, baffling may be required to extend the effective distance between the inflow point(s) and the outlet to minimize short-circuiting.
- **Dam Embankment:** It is recommended that embankment slopes be 4:1 (H:V) or flatter and no steeper than 3:1 (H:V) in any location.

Sediment Basins	
Functions	
Erosion Control	No
Sediment Control	Yes
Site/Material Management	No

- **Inflow Structure:** For concentrated flow entering the basin, provide energy dissipation at the point of inflow.

Table SB-1. Additional Volume Requirements for Undisturbed and Developed Tributary Areas Draining through Sediment Basins

Imperviousness (%)	Additional Storage Volume (ft³) Per Acre of Tributary Area
Undeveloped	500
10	800
20	1230
30	1600
40	2030
50	2470
60	2980
70	3560
80	4360
90	5300
100	6460

- **Outlet Works:** The outlet pipe shall extend through the embankment at a minimum slope of 0.5 percent. Outlet works can be designed using one of the following approaches:
 - **Riser Pipe (Simplified Detail):** Detail SB-1 provides a simplified design for basins treating no more than 15 acres.
 - **Orifice Plate or Riser Pipe:** Follow the design criteria for Full Spectrum Detention outlets in the EDB Fact Sheet provided in Chapter 4 of this manual for sizing of outlet perforations with an emptying time of approximately 72 hours. In lieu of the trash rack, pack uniformly sized 1½ - to 2-inch gravel in front of the plate or surrounding the riser pipe. This gravel will need to be cleaned out frequently during the construction period as sediment accumulates within it. The gravel pack will need to be removed and disposed of following construction to reclaim the basin for use as a permanent detention facility. If the basin will be used as a permanent extended detention basin for the site, a trash rack will need to be installed once contributing drainage areas have been stabilized and the gravel pack and accumulated sediment have been removed.
 - **Floating Skimmer:** If a floating skimmer is used, install it using manufacturer's recommendations. Illustration SB-1 provides an illustration of a Faircloth Skimmer Floating Outlet™, one of the more commonly used floating skimmer outlets. A skimmer should be designed to release the design volume in no less than 48 hours. The use of a floating skimmer outlet can increase the sediment capture efficiency of a basin significantly. A floating outlet continually decants cleanest water off the surface of the pond and releases cleaner water than would discharge from a perforated riser pipe or plate.

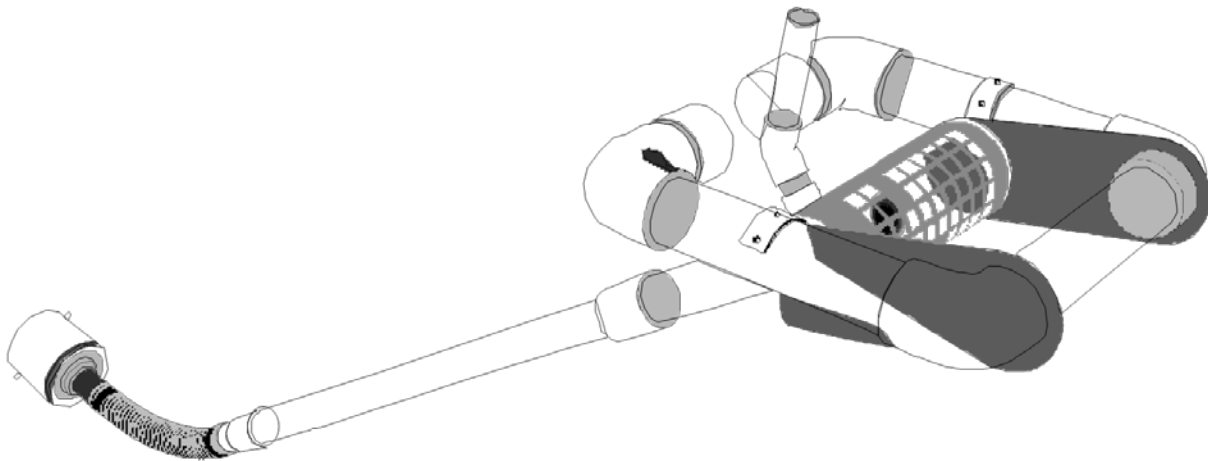

Illustration SB-1. Outlet structure for a temporary sediment basin - Faircloth Skimmer Floating Outlet. Illustration courtesy of J. W. Faircloth & Sons, Inc., FairclothSkimmer.com.

- **Outlet Protection and Spillway:** Consider all flow paths for runoff leaving the basin, including protection at the typical point of discharge as well as overtopping.
 - **Outlet Protection:** Outlet protection should be provided where the velocity of flow will exceed the maximum permissible velocity of the material of the waterway into which discharge occurs. This may require the use of a riprap apron at the outlet location and/or other measures to keep the waterway from eroding.
 - **Emergency Spillway:** Provide a stabilized emergency overflow spillway for rainstorms that exceed the capacity of the sediment basin volume and its outlet. Protect basin embankments from erosion and overtopping. If the sediment basin will be converted to a permanent detention basin, design and construct the emergency spillway(s) as required for the permanent facility. If the sediment basin will not become a permanent detention basin, it may be possible to substitute a heavy polyvinyl membrane or properly bedded rock cover to line the spillway and downstream embankment, depending on the height, slope, and width of the embankments.

Maintenance and Removal

Maintenance activities include the following:

- Dredge sediment from the basin, as needed to maintain BMP effectiveness, typically when the design storage volume is no more than one-third filled with sediment.
- Inspect the sediment basin embankments for stability and seepage.
- Inspect the inlet and outlet of the basin, repair damage, and remove debris. Remove, clean and replace the gravel around the outlet on a regular basis to remove the accumulated sediment within it and keep the outlet functioning.
- Be aware that removal of a sediment basin may require dewatering and associated permit requirements.
- Do not remove a sediment basin until the upstream area has been stabilized with vegetation.

Final disposition of the sediment basin depends on whether the basin will be converted to a permanent post-construction stormwater basin or whether the basin area will be returned to grade. For basins being converted to permanent detention basins, remove accumulated sediment and reconfigure the basin and outlet to meet the requirements of the final design for the detention facility. If the sediment basin is not to be used as a permanent detention facility, fill the excavated area with soil and stabilize with vegetation.

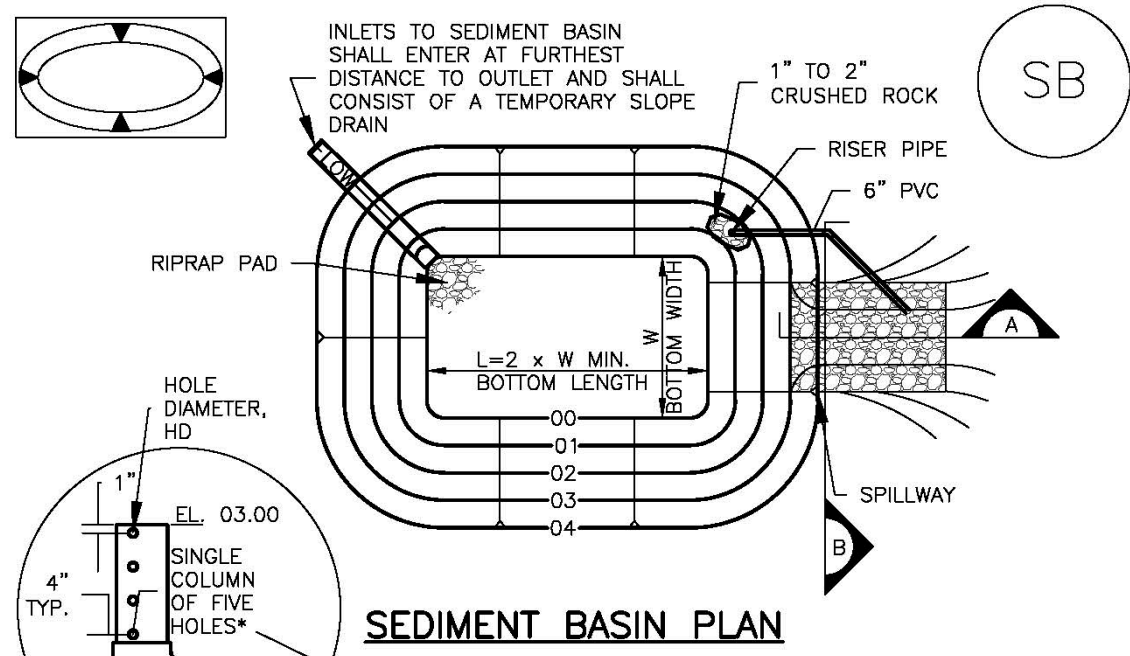

*EXCEPT WHERE THE HOLES EXCEED 1" DIAMETER, THEN UP TO TWO COLUMNS OF SAME SIZED HOLES MAY BE USED

TABLE SB-1. SIZING INFORMATION FOR STANDARD SEDIMENT BASIN			
Upstream Drainage Area (rounded to nearest acre), (ac)	Basin Bottom Width (W), (ft)	Spillway Crest Length (CL), (ft)	Hole Diameter (HD), (in)
1	12 1/2	2	9/32
2	21	3	13/16
3	28	5	1/2
4	33 1/2	6	9/16
5	38 1/2	8	2 1/32
6	43	9	2 1/32
7	47 1/4	11	2 5/32
8	51	12	2 7/32
9	55	13	7/8
10	58 1/4	15	1 5/16
11	61	16	3 1/32
12	64	18	1
13	67 1/2	19	1 1/16
14	70 1/2	21	1 1/8
15	73 1/4	22	1 3/16

SEDIMENT BASIN INSTALLATION NOTES

1. SEE PLAN VIEW FOR:
 - LOCATION OF SEDIMENT BASIN.
 - TYPE OF BASIN (STANDARD BASIN OR NONSTANDARD BASIN).
 - FOR STANDARD BASIN, BOTTOM WIDTH W, CREST LENGTH CL, AND HOLE DIAMETER, HD.
 - FOR NONSTANDARD BASIN, SEE CONSTRUCTION DRAWINGS FOR DESIGN OF BASIN INCLUDING RISER HEIGHT H, NUMBER OF COLUMNS N, HOLE DIAMETER HD AND PIPE DIAMETER D.
2. FOR STANDARD BASIN, BOTTOM DIMENSION MAY BE MODIFIED AS LONG AS BOTTOM AREA IS NOT REDUCED.
3. SEDIMENT BASINS SHALL BE INSTALLED PRIOR TO ANY OTHER LAND-DISTURBING ACTIVITY THAT RELIES ON ON BASINS AS AS A STORMWATER CONTROL.
4. EMBANKMENT MATERIAL SHALL CONSIST OF SOIL FREE OF DEBRIS, ORGANIC MATERIAL, AND ROCKS OR CONCRETE GREATER THAN 3 INCHES AND SHALL HAVE A MINIMUM OF 15 PERCENT BY WEIGHT PASSING THE NO. 200 SIEVE.
5. EMBANKMENT MATERIAL SHALL BE COMPACTED TO AT LEAST 95 PERCENT OF MAXIMUM DENSITY IN ACCORDANCE WITH ASTM D698.
6. PIPE SCH 40 OR GREATER SHALL BE USED.
7. THE DETAILS SHOWN ON THESE SHEETS PERTAIN TO STANDARD SEDIMENT BASIN(S) FOR DRAINAGE AREAS LESS THAN 15 ACRES. SEE CONSTRUCTION DRAWINGS FOR EMBANKMENT, STORAGE VOLUME, SPILLWAY, OUTLET, AND OUTLET PROTECTION DETAILS FOR ANY SEDIMENT BASIN(S) THAT HAVE BEEN INDIVIDUALLY DESIGNED FOR DRAINAGE AREAS LARGER THAN 15 ACRES.

SEDIMENT BASIN MAINTENANCE NOTES

1. INSPECT BMPs EACH WORKDAY, AND MAINTAIN THEM IN EFFECTIVE OPERATING CONDITION. MAINTENANCE OF BMPs SHOULD BE PROACTIVE, NOT REACTIVE. INSPECT BMPs AS SOON AS POSSIBLE (AND ALWAYS WITHIN 24 HOURS) FOLLOWING A STORM THAT CAUSES SURFACE EROSION, AND PERFORM NECESSARY MAINTENANCE.
2. FREQUENT OBSERVATIONS AND MAINTENANCE ARE NECESSARY TO MAINTAIN BMPs IN EFFECTIVE OPERATING CONDITION. INSPECTIONS AND CORRECTIVE MEASURES SHOULD BE DOCUMENTED THOROUGHLY.
3. WHERE BMPs HAVE FAILED, REPAIR OR REPLACEMENT SHOULD BE INITIATED UPON DISCOVERY OF THE FAILURE.
4. SEDIMENT ACCUMULATED IN BASIN SHALL BE REMOVED AS NEEDED TO MAINTAIN BMP EFFECTIVENESS, TYPICALLY WHEN SEDIMENT DEPTH REACHES ONE FOOT (I.E., TWO FEET BELOW THE SPILLWAY CREST).
5. SEDIMENT BASINS ARE TO REMAIN IN PLACE UNTIL THE UPSTREAM DISTURBED AREA IS STABILIZED AND GRASS COVER IS ACCEPTED BY THE LOCAL JURISDICTION.
6. WHEN SEDIMENT BASINS ARE REMOVED, ALL DISTURBED AREAS SHALL BE COVERED WITH TOPSOIL, SEEDED AND MULCHED OR OTHERWISE STABILIZED AS APPROVED BY LOCAL JURISDICTION.

(DETAILS ADAPTED FROM DOUGLAS COUNTY, COLORADO)

NOTE: MANY JURISDICTIONS HAVE BMP DETAILS THAT VARY FROM UDFCD STANDARD DETAILS. CONSULT WITH LOCAL JURISDICTIONS AS TO WHICH DETAIL SHOULD BE USED WHEN DIFFERENCES ARE NOTED.

Description

Temporary seeding can be used to stabilize disturbed areas that will be inactive for an extended period. Permanent seeding should be used to stabilize areas at final grade that will not be otherwise stabilized. Effective seeding includes preparation of a seedbed, selection of an appropriate seed mixture, proper planting techniques, and protection of the seeded area with mulch, geotextiles, or other appropriate measures.



Photograph TS/PS -1. Equipment used to drill seed. Photo courtesy of Douglas County.

Appropriate Uses

When the soil surface is disturbed and will remain inactive for an extended period (typically 30 days or longer), proactive stabilization measures should be implemented. If the inactive period is short-lived (on the order of two weeks), techniques such as surface roughening may be appropriate. For longer periods of inactivity, temporary seeding and mulching can provide effective erosion control. Permanent seeding should be used on finished areas that have not been otherwise stabilized.

Typically, local governments have their own seed mixes and timelines for seeding. Check jurisdictional requirements for seeding and temporary stabilization.

Design and Installation

Effective seeding requires proper seedbed preparation, selection of an appropriate seed mixture, use of appropriate seeding equipment to ensure proper coverage and density, and protection with mulch or fabric until plants are established.

The USDCM Volume 2 *Revegetation* Chapter contains detailed seed mix, soil preparations, and seeding and mulching recommendations that may be referenced to supplement this Fact Sheet.

Drill seeding is the preferred seeding method. Hydroseeding is not recommended except in areas where steep slopes prevent use of drill seeding equipment, and even in these instances it is preferable to hand seed and mulch. Some jurisdictions do not allow hydroseeding or hydromulching.

Seedbed Preparation

Prior to seeding, ensure that areas to be revegetated have soil conditions capable of supporting vegetation. Overlot grading can result in loss of topsoil, resulting in poor quality subsoils at the ground surface that have low nutrient value, little organic matter content, few soil microorganisms, rooting restrictions, and conditions less conducive to infiltration of precipitation. As a result, it is typically necessary to provide stockpiled topsoil, compost, or other

Temporary and Permanent Seeding	
Functions	
Erosion Control	Yes
Sediment Control	No
Site/Material Management	No

EC-2 Temporary and Permanent Seeding (TS/PS)

soil amendments and rototill them into the soil to a depth of 6 inches or more.

Topsoil should be salvaged during grading operations for use and spread on areas to be revegetated later. Topsoil should be viewed as an important resource to be utilized for vegetation establishment, due to its water-holding capacity, structure, texture, organic matter content, biological activity, and nutrient content. The rooting depth of most native grasses in the semi-arid Denver metropolitan area is 6 to 18 inches. At a minimum, the upper 6 inches of topsoil should be stripped, stockpiled, and ultimately respread across areas that will be revegetated.

Where topsoil is not available, subsoils should be amended to provide an appropriate plant-growth medium. Organic matter, such as well digested compost, can be added to improve soil characteristics conducive to plant growth. Other treatments can be used to adjust soil pH conditions when needed. Soil testing, which is typically inexpensive, should be completed to determine and optimize the types and amounts of amendments that are required.

If the disturbed ground surface is compacted, rip or rototill the surface prior to placing topsoil. If adding compost to the existing soil surface, rototilling is necessary. Surface roughening will assist in placement of a stable topsoil layer on steeper slopes, and allow infiltration and root penetration to greater depth.

Prior to seeding, the soil surface should be rough and the seedbed should be firm, but neither too loose nor compacted. The upper layer of soil should be in a condition suitable for seeding at the proper depth and conducive to plant growth. Seed-to-soil contact is the key to good germination.

Seed Mix for Temporary Vegetation

To provide temporary vegetative cover on disturbed areas which will not be paved, built upon, or fully landscaped or worked for an extended period (typically 30 days or more), plant an annual grass appropriate for the time of planting and mulch the planted areas. Annual grasses suitable for the Denver metropolitan area are listed in Table TS/PS-1. These are to be considered only as general recommendations when specific design guidance for a particular site is not available. Local governments typically specify seed mixes appropriate for their jurisdiction.

Seed Mix for Permanent Revegetation

To provide vegetative cover on disturbed areas that have reached final grade, a perennial grass mix should be established. Permanent seeding should be performed promptly (typically within 14 days) after reaching final grade. Each site will have different characteristics and a landscape professional or the local jurisdiction should be contacted to determine the most suitable seed mix for a specific site. In lieu of a specific recommendation, one of the perennial grass mixes appropriate for site conditions and growth season listed in Table TS/PS-2 can be used. The pure live seed (PLS) rates of application recommended in these tables are considered to be absolute minimum rates for seed applied using proper drill-seeding equipment.

If desired for wildlife habitat or landscape diversity, shrubs such as rubber rabbitbrush (*Chrysothamnus nauseosus*), fourwing saltbush (*Atriplex canescens*) and skunkbrush sumac (*Rhus trilobata*) could be added to the upland seedmixes at 0.25, 0.5 and 1 pound PLS/acre, respectively. In riparian zones, planting root stock of such species as American plum (*Prunus americana*), woods rose (*Rosa woodsii*), plains cottonwood (*Populus sargentii*), and willow (*Populus spp.*) may be considered. On non-topsoiled upland sites, a legume such as Ladak alfalfa at 1 pound PLS/acre can be included as a source of nitrogen for perennial grasses.

Seeding dates for the highest success probability of perennial species along the Front Range are generally in the spring from April through early May and in the fall after the first of September until the ground freezes. If the area is irrigated, seeding may occur in summer months, as well. See Table TS/PS-3 for appropriate seeding dates.

Table TS/PS-1. Minimum Drill Seeding Rates for Various Temporary Annual Grasses

Species ^a (Common name)	Growth Season ^b	Pounds of Pure Live Seed (PLS)/acre ^c	Planting Depth (inches)
1. Oats	Cool	35 - 50	1 - 2
2. Spring wheat	Cool	25 - 35	1 - 2
3. Spring barley	Cool	25 - 35	1 - 2
4. Annual ryegrass	Cool	10 - 15	½
5. Millet	Warm	3 - 15	½ - ¾
6. Sudangrass	Warm	5-10	½ - ¾
7. Sorghum	Warm	5-10	½ - ¾
8. Winter wheat	Cool	20-35	1 - 2
9. Winter barley	Cool	20-35	1 - 2
10. Winter rye	Cool	20-35	1 - 2
11. Triticale	Cool	25-40	1 - 2

^a Successful seeding of annual grass resulting in adequate plant growth will usually produce enough dead-plant residue to provide protection from wind and water erosion for an additional year. This assumes that the cover is not disturbed or mowed closer than 8 inches.

Hydraulic seeding may be substituted for drilling only where slopes are steeper than 3:1 or where access limitations exist. When hydraulic seeding is used, hydraulic mulching should be applied as a separate operation, when practical, to prevent the seeds from being encapsulated in the mulch.

^b See Table TS/PS-3 for seeding dates. Irrigation, if consistently applied, may extend the use of cool season species during the summer months.

^c Seeding rates should be doubled if seed is broadcast, or increased by 50 percent if done using a Brillion Drill or by hydraulic seeding.

EC-2 Temporary and Permanent Seeding (TS/PS)

Table TS/PS-2. Minimum Drill Seeding Rates for Perennial Grasses

Common ^a Name	Botanical Name	Growth Season ^b	Growth Form	Seeds/ Pound	Pounds of PLS/acre
Alakali Soil Seed Mix					
Alkali sacaton	<i>Sporobolus airoides</i>	Cool	Bunch	1,750,000	0.25
Basin wildrye	<i>Elymus cinereus</i>	Cool	Bunch	165,000	2.5
Sodar streambank wheatgrass	<i>Agropyron riparium 'Sodar'</i>	Cool	Sod	170,000	2.5
Jose tall wheatgrass	<i>Agropyron elongatum 'Jose'</i>	Cool	Bunch	79,000	7.0
Arriba western wheatgrass	<i>Agropyron smithii 'Arriba'</i>	Cool	Sod	110,000	5.5
Total					17.75
Fertile Loamy Soil Seed Mix					
Ephriam crested wheatgrass	<i>Agropyron cristatum 'Ephriam'</i>	Cool	Sod	175,000	2.0
Dural hard fescue	<i>Festuca ovina 'duriuscula'</i>	Cool	Bunch	565,000	1.0
Lincoln smooth brome	<i>Bromus inermis leys 'Lincoln'</i>	Cool	Sod	130,000	3.0
Sodar streambank wheatgrass	<i>Agropyron riparium 'Sodar'</i>	Cool	Sod	170,000	2.5
Arriba western wheatgrass	<i>Agropyron smithii 'Arriba'</i>	Cool	Sod	110,000	7.0
Total					15.5
High Water Table Soil Seed Mix					
Meadow foxtail	<i>Alopecurus pratensis</i>	Cool	Sod	900,000	0.5
Redtop	<i>Agrostis alba</i>	Warm	Open sod	5,000,000	0.25
Reed canarygrass	<i>Phalaris arundinacea</i>	Cool	Sod	68,000	0.5
Lincoln smooth brome	<i>Bromus inermis leys 'Lincoln'</i>	Cool	Sod	130,000	3.0
Pathfinder switchgrass	<i>Panicum virgatum 'Pathfinder'</i>	Warm	Sod	389,000	1.0
Alkar tall wheatgrass	<i>Agropyron elongatum 'Alkar'</i>	Cool	Bunch	79,000	5.5
Total					10.75
Transition Turf Seed Mix^c					
Ruebens Canadian bluegrass	<i>Poa compressa 'Ruebens'</i>	Cool	Sod	2,500,000	0.5
Dural hard fescue	<i>Festuca ovina 'duriuscula'</i>	Cool	Bunch	565,000	1.0
Citation perennial ryegrass	<i>Lolium perenne 'Citation'</i>	Cool	Sod	247,000	3.0
Lincoln smooth brome	<i>Bromus inermis leys 'Lincoln'</i>	Cool	Sod	130,000	3.0
Total					7.5

Table TS/PS-2. Minimum Drill Seeding Rates for Perennial Grasses (cont.)

Common Name	Botanical Name	Growth Season ^b	Growth Form	Seeds/Pound	Pounds of PLS/acre
Sandy Soil Seed Mix					
Blue grama	<i>Bouteloua gracilis</i>	Warm	Sod-forming bunchgrass	825,000	0.5
Camper little bluestem	<i>Schizachyrium scoparium</i> 'Camper'	Warm	Bunch	240,000	1.0
Prairie sandreed	<i>Calamovilfa longifolia</i>	Warm	Open sod	274,000	1.0
Sand dropseed	<i>Sporobolus cryptandrus</i>	Cool	Bunch	5,298,000	0.25
Vaughn sideoats grama	<i>Bouteloua curtipendula</i> 'Vaughn'	Warm	Sod	191,000	2.0
Arriba western wheatgrass	<i>Agropyron smithii</i> 'Arriba'	Cool	Sod	110,000	5.5
Total					10.25
Heavy Clay, Rocky Foothill Seed Mix					
Ephriam crested wheatgrass ^d	<i>Agropyron cristatum</i> 'Ephriam'	Cool	Sod	175,000	1.5
Oahe Intermediate wheatgrass	<i>Agropyron intermedium</i> 'Oahe'	Cool	Sod	115,000	5.5
Vaughn sideoats grama ^e	<i>Bouteloua curtipendula</i> 'Vaughn'	Warm	Sod	191,000	2.0
Lincoln smooth brome	<i>Bromus inermis</i> leys 'Lincoln'	Cool	Sod	130,000	3.0
Arriba western wheatgrass	<i>Agropyron smithii</i> 'Arriba'	Cool	Sod	110,000	5.5
Total					17.5
<p>^a All of the above seeding mixes and rates are based on drill seeding followed by crimped straw mulch. These rates should be doubled if seed is broadcast and should be increased by 50 percent if the seeding is done using a Brillion Drill or is applied through hydraulic seeding. Hydraulic seeding may be substituted for drilling only where slopes are steeper than 3:1. If hydraulic seeding is used, hydraulic mulching should be done as a separate operation.</p> <p>^b See Table TS/PS-3 for seeding dates.</p> <p>^c If site is to be irrigated, the transition turf seed rates should be doubled.</p> <p>^d Crested wheatgrass should not be used on slopes steeper than 6H to 1V.</p> <p>^e Can substitute 0.5 lbs PLS of blue grama for the 2.0 lbs PLS of Vaughn sideoats grama.</p>					

EC-2 Temporary and Permanent Seeding (TS/PS)

Table TS/PS-3. Seeding Dates for Annual and Perennial Grasses

Seeding Dates	Annual Grasses (Numbers in table reference species in Table TS/PS-1)		Perennial Grasses	
	Warm	Cool	Warm	Cool
January 1–March 15			✓	✓
March 16–April 30	4	1,2,3	✓	✓
May 1–May 15	4		✓	
May 16–June 30	4,5,6,7			
July 1–July 15	5,6,7			
July 16–August 31				
September 1–September 30		8,9,10,11		
October 1–December 31			✓	✓

Mulch

Cover seeded areas with mulch or an appropriate rolled erosion control product to promote establishment of vegetation. Anchor mulch by crimping, netting or use of a non-toxic tackifier. See the Mulching BMP Fact Sheet for additional guidance.

Maintenance and Removal

Monitor and observe seeded areas to identify areas of poor growth or areas that fail to germinate. Reseed and mulch these areas, as needed.

An area that has been permanently seeded should have a good stand of vegetation within one growing season if irrigated and within three growing seasons without irrigation in Colorado. Reseed portions of the site that fail to germinate or remain bare after the first growing season.

Seeded areas may require irrigation, particularly during extended dry periods. Targeted weed control may also be necessary.

Protect seeded areas from construction equipment and vehicle access.

GRADING AND EROSION CONTROL PLANS

GRADING AND EROSION CONTROL NOTES:

- STORMWATER DISCHARGES FROM CONSTRUCTION SITES SHALL NOT CAUSE OR THREATEN TO CAUSE POLLUTION, CONTAMINATION, OR DEGRADATION OF STATE WATERS. ALL WORK AND EARTH DISTURBANCE SHALL BE DONE IN A MANNER THAT MINIMIZES POLLUTION OF ANY ON-SITE OR OFF-SITE WATERS, INCLUDING WETLANDS.
- NOTWITHSTANDING ANYTHING DEPICTED IN THESE PLANS IN WORDS OR GRAPHIC REPRESENTATION, ALL DESIGN AND CONSTRUCTION RELATED TO ROADS, STORM DRAINAGE AND EROSION CONTROL SHALL CONFORM TO THE STANDARDS AND REQUIREMENTS OF THE MOST RECENT VERSION OF THE RELEVANT ADOPTED EL PASO COUNTY STANDARDS, INCLUDING THE LAND DEVELOPMENT CODE, THE ENGINEERING CRITERIA MANUAL, THE DRAINAGE CRITERIA MANUAL, AND THE DRAINAGE CRITERIA MANUAL VOLUME 2. ANY DEVIATIONS FROM REGULATIONS AND STANDARDS MUST BE REQUESTED, AND APPROVED, IN WRITING.
- A SEPARATE STORMWATER MANAGEMENT PLAN (SWMP) FOR THIS PROJECT SHALL BE COMPLETED AND AN EROSION AND STORMWATER QUALITY CONTROL PERMIT (ESQCP) ISSUED PRIOR TO COMMENCING CONSTRUCTION. MANAGEMENT OF THE SWMP DURING CONSTRUCTION IS THE RESPONSIBILITY OF THE DESIGNATED QUALIFIED STORMWATER MANAGER OR CERTIFIED EROSION CONTROL INSPECTOR. THE SWMP SHALL BE LOCATED ON SITE AT ALL TIMES DURING CONSTRUCTION AND SHALL BE KEPT UP TO DATE WITH WORK PROGRESS AND CHANGES IN THE FIELD.
- ONCE THE ESQCP IS APPROVED AND A 'NOTICE TO PROCEED' HAS BEEN ISSUED, THE CONTRACTOR MAY INSTALL THE INITIAL STAGE EROSION AND SEDIMENT CONTROL MEASURES AS INDICATED ON THE APPROVED GEC. A PRECONSTRUCTION MEETING BETWEEN THE CONTRACTOR, ENGINEER, AND EL PASO COUNTY WILL BE HELD PRIOR TO ANY CONSTRUCTION. IT IS THE RESPONSIBILITY OF THE APPLICANT TO COORDINATE THE MEETING TIME AND PLACE WITH COUNTY STAFF.
- CONTROL MEASURES MUST BE INSTALLED PRIOR TO COMMENCEMENT OF ACTIVITIES THAT COULD CONTRIBUTE POLLUTANTS TO STORMWATER. CONTROL MEASURES FOR ALL SLOPES, CHANNELS, DITCHES, AND DISTURBED LAND AREAS SHALL BE INSTALLED IMMEDIATELY UPON COMPLETION OF THE DISTURBANCE.
- ALL TEMPORARY SEDIMENT AND EROSION CONTROL MEASURES SHALL BE MAINTAINED AND REMAIN IN EFFECTIVE OPERATING CONDITION UNTIL PERMANENT SOIL EROSION CONTROL MEASURES ARE IMPLEMENTED AND FINAL STABILIZATION IS ESTABLISHED. ALL PERSONS ENGAGED IN LAND DISTURBANCE ACTIVITIES SHALL ASSESS THE ADEQUACY OF CONTROL MEASURES AT THE SITE AND IDENTIFY IF CHANGES TO THOSE CONTROL MEASURES ARE NEEDED TO ENSURE THE CONTINUED EFFECTIVE PERFORMANCE OF THE CONTROL MEASURES. ALL CHANGES TO TEMPORARY SEDIMENT AND EROSION CONTROL MEASURES MUST BE INCORPORATED INTO THE STORMWATER MANAGEMENT PLAN.
- TEMPORARY STABILIZATION SHALL BE IMPLEMENTED ON DISTURBED AREAS AND STOCKPILES WHERE GROUND DISTURBING CONSTRUCTION ACTIVITY HAS PERMANENTLY CEASED OR TEMPORARILY CEASED FOR LONGER THAN 14 DAYS.
- FINAL STABILIZATION MUST BE IMPLEMENTED AT ALL APPLICABLE CONSTRUCTION SITES. FINAL STABILIZATION IS ACHIEVED WHEN ALL GROUND DISTURBING ACTIVITIES ARE COMPLETE AND ALL DISTURBED AREAS EITHER HAVE A UNIFORM VEGETATIVE COVER WITH INDIVIDUAL PLANT DENSITY OF 70 PERCENT OF PRE-DISTURBANCE LEVELS ESTABLISHED OR EQUIVALENT PERMANENT ALTERNATIVE STABILIZATION METHOD IS IMPLEMENTED. ALL TEMPORARY SEDIMENT AND EROSION CONTROL MEASURES SHALL BE REMOVED UPON FINAL STABILIZATION AND BEFORE PERMIT CLOSURE.
- ALL PERMANENT STORMWATER MANAGEMENT FACILITIES SHALL BE INSTALLED AS DESIGNED IN THE APPROVED PLANS. ANY PROPOSED CHANGES THAT EFFECT THE DESIGN OR FUNCTION OF PERMANENT STORMWATER MANAGEMENT STRUCTURES MUST BE APPROVED BY THE ECM ADMINISTRATOR PRIOR TO IMPLEMENTATION.
- EARTH DISTURBANCES SHALL BE CONDUCTED IN SUCH A MANNER SO AS TO EFFECTIVELY MINIMIZE ACCELERATED SOIL EROSION AND RESULTING SEDIMENT. STABILIZATION ACTIVITIES SHALL BE DESIGNED, CONSTRUCTED, AND COMPLETED SO THAT THE EXPOSED AREA OF ANY DISTURBED LAND SHALL BE LIMITED TO THE SHORTEST PRACTICAL PERIOD OF TIME. PRE-EXISTING VEGETATION SHALL BE PROTECTED AND MAINTAINED WITHIN 50 HORIZONTAL FEET OF A WATERS OF THE STATE UNLESS SHOWN TO BE INFEASIBLE AND SPECIFICALLY REQUESTED AND APPROVED.
- COMPACTION OF SOIL MUST BE PREVENTED IN AREAS DESIGNATED FOR INFILTRATION CONTROL MEASURES OR WHERE FINAL STABILIZATION WILL BE ACHIEVED BY VEGETATIVE COVER. AREAS DESIGNATED FOR INFILTRATION CONTROL MEASURES SHALL ALSO BE PROTECTED FROM SEDIMENTATION DURING CONSTRUCTION UNTIL FINAL STABILIZATION IS ACHIEVED. IF COMPACTION PREVENTION IS NOT FEASIBLE DUE TO SITE CONSTRAINTS, ALL AREAS DESIGNATED FOR INFILTRATION AND VEGETATION CONTROL MEASURES MUST BE LOOSENEED PRIOR TO INSTALLATION OF THE CONTROL MEASURE(S).
- ANY TEMPORARY OR PERMANENT FACILITY DESIGNED AND CONSTRUCTED FOR THE CONVEYANCE OF STORMWATER AROUND, THROUGH, OR FROM THE EARTH DISTURBANCE AREA SHALL BE A STABILIZED CONVEYANCE DESIGNED TO MINIMIZE EROSION AND THE DISCHARGE OF SEDIMENT OFF SITE.
- CONCRETE WASH WATER SHALL BE CONTAINED AND DISPOSED OF IN ACCORDANCE WITH THE SWMP. NO WASH WATER SHALL BE DISCHARGED TO OR ALLOWED TO ENTER STATE WATERS, INCLUDING ANY SURFACE OR SUBSURFACE STORM DRAINAGE SYSTEM OR FACILITIES. CONCRETE WASHOUTS SHALL NOT BE LOCATED IN AN AREA WHERE SHALLOW GROUNDWATER MAY BE PRESENT, OR WITHIN 50 FEET OF A SURFACE WATER BODY, CREEK OR STREAM.
- DURING DEWATERING OPERATIONS OF UNCONTAMINATED GROUND WATER MAY BE DISCHARGED ON SITE, BUT SHALL NOT LEAVE THE SITE IN THE FORM OF SURFACE RUNOFF UNLESS AN APPROVED STATE DEWATERING PERMIT IS IN PLACE.
- EROSION CONTROL BLANKETING OR OTHER PROTECTIVE COVERING SHALL BE USED ON SLOPES STEEPER THAN 3:1.
- CONTRACTOR SHALL BE RESPONSIBLE FOR THE REMOVAL OF ALL WASTES FROM THE CONSTRUCTION SITE FOR DISPOSAL IN ACCORDANCE WITH LOCAL AND STATE REGULATIONS. NO CONSTRUCTION DEBRIS, TREE SLASH, BUILDING MATERIAL WASTES OR UNUSED BUILDING MATERIALS SHALL BE BURIED, DUMPED, OR DISCHARGED AT THE SITE.
- WASTE MATERIALS SHALL NOT BE TEMPORARILY PLACED OR STORED IN THE STREET, ALLEY, OR OTHER PUBLIC WAY, UNLESS IN ACCORDANCE WITH AN APPROVED TRAFFIC CONTROL PLAN. CONTROL MEASURES MAY BE REQUIRED BY EL PASO COUNTY ENGINEERING IF DEEMED NECESSARY, BASED ON SPECIFIC CONDITIONS AND CIRCUMSTANCES.
- TRACKING OF SOILS AND CONSTRUCTION DEBRIS OFF-SITE SHALL BE MINIMIZED. MATERIALS TRACKED OFF-SITE SHALL BE CLEANED UP AND PROPERLY DISPOSED OF IMMEDIATELY.
- THE OWNER/DEVELOPER SHALL BE RESPONSIBLE FOR THE REMOVAL OF ALL CONSTRUCTION DEBRIS, DIRT, TRASH, ROCK, SEDIMENT, SOIL, AND SAND THAT MAY ACCUMULATE IN ROADS, STORM DRAINS AND OTHER DRAINAGE CONVEYANCE SYSTEMS AND STORMWATER APPURTENANCES AS A RESULT OF SITE DEVELOPMENT.
- THE QUANTITY OF MATERIALS STORED ON THE PROJECT SITE SHALL BE LIMITED, AS MUCH AS PRACTICAL, TO THAT QUANTITY REQUIRED TO PERFORM THE WORK IN AN ORDERLY SEQUENCE. ALL MATERIALS STORED ON-SITE SHALL BE STORED IN A NEAT, ORDERLY MANNER, IN THEIR ORIGINAL CONTAINERS, WITH ORIGINAL MANUFACTURER'S LABELS.
- NO CHEMICAL(S) HAVING THE POTENTIAL TO BE RELEASED IN STORMWATER ARE TO BE STORED OR USED ONSITE UNLESS PERMISSION FOR THE USE OF SUCH CHEMICAL(S) IS GRANTED IN WRITING BY THE ECM ADMINISTRATOR. IN GRANTING APPROVAL FOR THE USE OF SUCH CHEMICAL(S), SPECIAL CONDITIONS AND MONITORING MAY BE REQUIRED.
- BULK STORAGE OF ALLOWED PETROLEUM PRODUCTS OR OTHER ALLOWED LIQUID CHEMICALS IN EXCESS OF 55 GALLONS SHALL REQUIRE ADEQUATE SECONDARY CONTAINMENT PROTECTION TO CONTAIN ALL SPILLS ONSITE AND TO PREVENT ANY SPILLED MATERIALS FROM ENTERING STATE WATERS, ANY SURFACE OR SUBSURFACE STORM DRAINAGE SYSTEM OR OTHER FACILITIES.
- NO PERSON SHALL CAUSE THE IMPEDIMENT OF STORMWATER FLOW IN THE CURB AND GUTTER OR DITCH EXCEPT WITH APPROVED SEDIMENT CONTROL MEASURES.
- OWNER/DEVELOPER AND THEIR AGENTS SHALL COMPLY WITH THE 'COLORADO WATER QUALITY CONTROL ACT' (TITLE 25, ARTICLE 8, CRS); AND THE 'CLEAN WATER ACT' (33 USC 1344), IN ADDITION TO THE REQUIREMENTS OF THE LAND DEVELOPMENT CODE, DCM VOLUME II AND THE ECM APPENDIX I. ALL APPROPRIATE PERMITS MUST BE OBTAINED BY THE CONTRACTOR PRIOR TO CONSTRUCTION (1041, NPDES, FLOODPLAIN, 404, FUGITIVE DUST, ETC.). IN THE EVENT OF CONFLICTS BETWEEN THESE REQUIREMENTS AND OTHER LAWS, RULES, OR REGULATIONS OF OTHER FEDERAL, STATE, LOCAL, OR COUNTY AGENCIES, THE MOST RESTRICTIVE LAWS, RULES, OR REGULATIONS SHALL APPLY.
- ALL CONSTRUCTION TRAFFIC MUST ENTER/EXIT THE SITE ONLY AT APPROVED CONSTRUCTION ACCESS POINTS.
- PRIOR TO CONSTRUCTION THE PERMITTEE SHALL VERIFY THE LOCATION OF EXISTING UTILITIES.
- A WATER SOURCE SHALL BE AVAILABLE ON SITE DURING EARTHWORK OPERATIONS AND SHALL BE UTILIZED AS REQUIRED TO MINIMIZE DUST FROM EARTHWORK EQUIPMENT AND WIND.
- THE SOILS REPORT FOR THIS SITE HAS BEEN PREPARED BY ENTECH ENGINEERING, INC. #76021 JUNE 1, 2011 AND SHALL BE CONSIDERED A PART OF THESE PLANS.
- AT LEAST TEN (10) DAYS PRIOR TO THE ANTICIPATED START OF CONSTRUCTION, FOR PROJECTS THAT WILL DISTURB ONE (1) ACRE OR MORE, THE OWNER OR OPERATOR OF CONSTRUCTION ACTIVITY SHALL SUBMIT A PERMIT APPLICATION FOR STORMWATER DISCHARGE TO THE COLORADO DEPARTMENT OF PUBLIC HEALTH AND ENVIRONMENT, WATER QUALITY DIVISION. THE APPLICATION CONTAINS CERTIFICATION OF COMPLETION OF A STORMWATER MANAGEMENT PLAN (SWMP), OF WHICH THIS GRADING AND EROSION CONTROL PLAN MAY BE A PART. FOR INFORMATION OR APPLICATION MATERIALS CONTACT:
COLORADO DEPARTMENT OF PUBLIC HEALTH AND ENVIRONMENT
WATER QUALITY CONTROL DIVISION
WGCD - PERMITS
4300 CHERRY CREEK DRIVE SOUTH
DENVER, CO 80246-1530
ATTN: PERMITS UNIT

CLAREMONT BUSINESS PARK FILING NO. 3

COUNTY OF EL PASO, STATE OF COLORADO

GRADING AND EROSION CONTROL PLAN

JUNE 2020

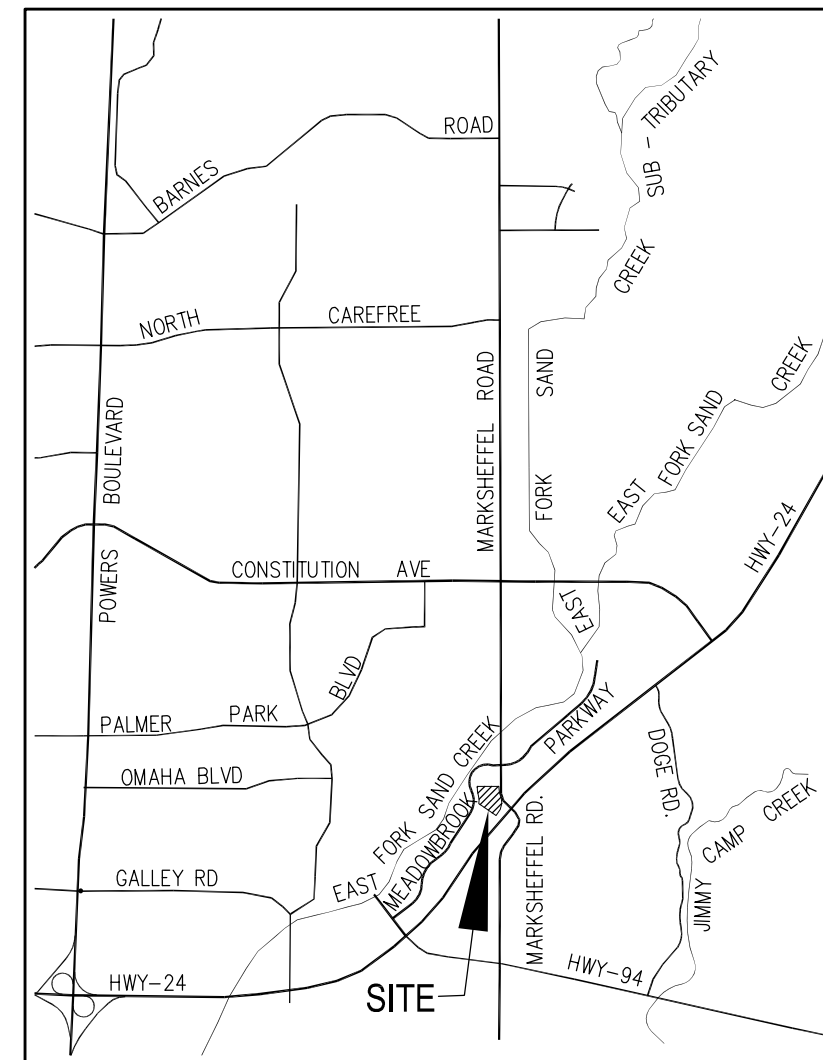

VICINITY MAP
N.T.S.

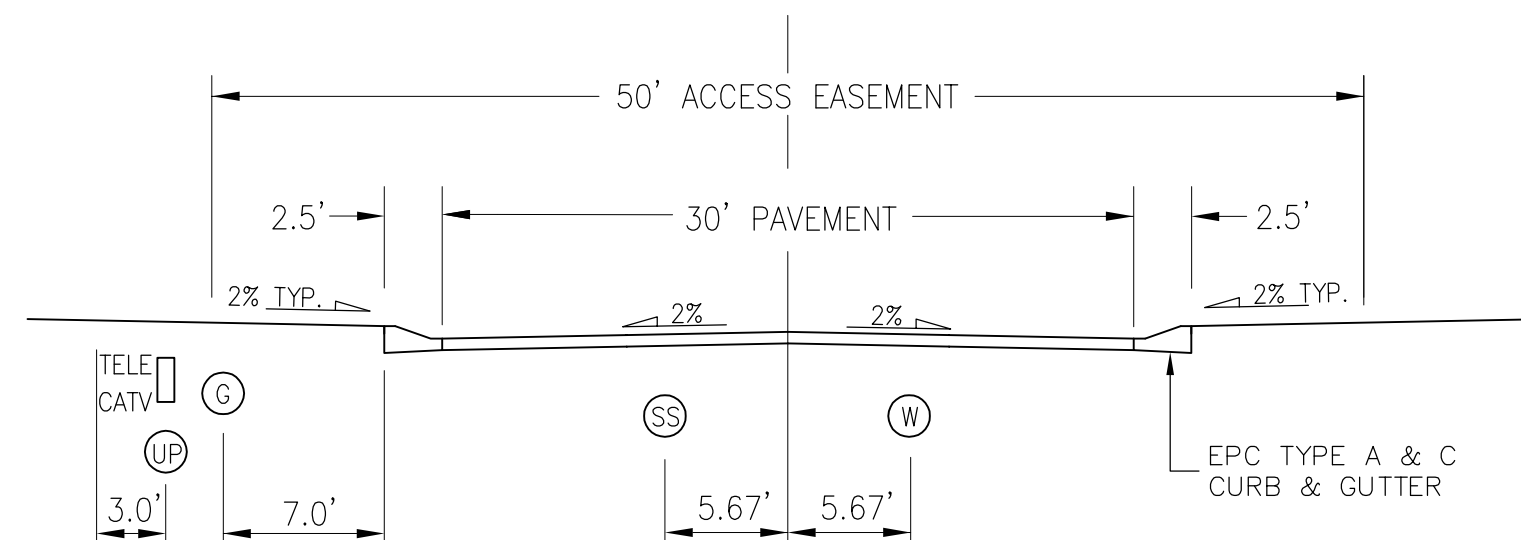

URBAN LOCAL CROSS SECTION (PRIVATE)
SCALE: NTS

POSTED SPEED 25 MPH
DESIGN SPEED 35 MPH

BASIS OF BEARINGS

BASIS OF BEARINGS: THE CHORD OF THE WESTERLY LINE OF LOT 2, CLAREMONT BUSINESS PARK FILING NO. 1A UNDER RECEPTION NO. 206712398, BEING MONUMENTED AT THE SOUTHERLY END WITH A NAIL AND WASHER, PLS NO ILLEGIBLE, AND AT THE NORTHERLY END WITH A REBAR AND ALUMINUM CAP PLS NO. 27605 IS ASSUMED TO BEAR N22°18'18"E, A DISTANCE OF 218.26 FEET.

BENCHMARKS

- BL33 BEING A BENRTSEN TOP SECURITY MONUMENT IN RANGE BOX 5' SOUTH OF SOUTH ROW FENCE OF HWY 24 UNDER CENTERLINE OF TRANSMISSION LINE. ELEVATION = 6455.17'
- CONTROL POINT 1, SET PK NAIL IN NE CORNER OF ELECTRIC TRANSFORMER PAD ELEVATION = 6372.26'

LEGEND

---	LIMIT OF DISTURBANCE	H.P.	HIGH POINT
- - -	CUT/FILL LINE	L.P.	LOW POINT
---	(6920) EXISTING CONTOUR	(SF) — s	SILT FENCE
---	6920 PROP CONTOUR	(VTC)	VEHICLE TRACKING CONTROL
---	STORM SEWER PIPE	(IP)	INLET PROTECTION
---	INLET	(SBB)	STRAW BALE DITCH CHECK
---	EXISTING FLOW DIRECTION ARROW	(ECB)	EROSION CONTROL BLANKET
---	EMERGENCY OVERFLOW DIRECTION		
---	FLOW DIRECTION		
---	FLARED END SECTION		

ADDITIONAL NOTES:

STAGING AREA TO BE DETERMINED BY CONTRACTOR IN THE FIELD. THE LOCATIONS SHALL BE DELINEATED ON THIS PLAN BY THE CONTRACTOR.
THE EROSION CONTROL DELINEATED ON THIS PLAN SHALL BE REGULARLY UPDATED BY THE CONTRACTOR.
TEMPORARY SEDIMENT TRAP LOCATIONS WILL BE DETERMINED BY THE CONTRACTOR IN THE FIELD.
EXISTING SITE TERRAIN GENERALLY SLOPES FROM NORTH TO SOUTHWEST AT GRADE RATES THAT VARY BETWEEN 2% TO 6%.
THERE ARE NO BATCH PLANTS ON SITE.
AREAS LEFT OPEN FOR 30 DAYS OR MORE, OTHER THAN FOR UTILITY AND DRAINAGE CONSTRUCTION SHALL BE SEEDED AND/OR MULCHED.

NO PORTION OF THIS PROPERTY IS LOCATED WITHIN A DESIGNATED FEMA FLOODPLAIN IN ACCORDANCE WITH FLOOD INSURANCE RATE MAPS (FIRM) 08041C0756G, EFFECTIVE DATE DECEMBER 7, 2018.

EXISTING VEGETATION: THE SITE ORIGINALLY CONSISTED OF PRAIRIE GRASSES AND SHRUBS. NO OTHER NOTABLE VEGETATION EXISTED. THE SITE IS PROPOSED FOR AN INDUSTRIAL PARK SUBDIVISION. IF THE SUBDIVISION IS NOT COMPLETED, THE ENTIRE SITE SHOULD BE RESEEDED PER EPC SPECIFICATIONS. FOR AREAS OUTSIDE OF THE DEVELOPED LOTS, THE GROUND SHOULD BE RESEEDED PER EPC CRITERIA AS SHOWN ON THE GRADING AND EROSION CONTROL PLAN. THE VEGETATION SHOULD BE VISUALLY INSPECTED TO EXCEED THE AMOUNT OF VEGETATION THAT EXISTS IN NON-DISTURBED AREAS AROUND THE SITE.

GRADING & EROSION CONTROL PLAN
CLAREMONT BUSINESS PARK FIL. NO. 3
JOB NO. 44-037
DATE PREPARED: APRIL 28, 2020
DATE REVISED: JUNE 29, 2020

EL PASO COUNTY FILE NO. SP 197



DESIGN ENGINEER'S STATEMENT

THIS GRADING AND EROSION CONTROL PLAN WAS PREPARED UNDER MY DIRECTION AND SUPERVISION AND IS CORRECT TO THE BEST OF MY KNOWLEDGE AND BELIEF. SAID PLAN HAS BEEN PREPARED ACCORDING TO THE CRITERIA ESTABLISHED BY THE CHEROKEE METROPOLITAN DISTRICT. I ACCEPT RESPONSIBILITY FOR ANY LIABILITY CAUSED BY NEGLIGENT ACTS, ERRORS OR OMISSIONS ON MY PART IN PREPARING THIS PLAN.

VRGL A. SANCHEZ, COLORADO P.E. #37160 DATE
FOR AND ON BEHALF OF M & S CIVIL CONSULTANTS, INC.

OWNER/DEVELOPER'S STATEMENT:

I, THE OWNER/DEVELOPER HAVE READ AND WILL COMPLY WITH THE REQUIREMENTS IN THESE DETAILED PLANS AND SPECIFICATIONS.

HAMMERS CONSTRUCTION, INC. DATE

ADDRESS: 1411 WOOLSEY HEIGHTS, COLORADO SPRINGS, CO 80915

EL PASO COUNTY:

COUNTY PLAN REVIEW IS PROVIDED ONLY FOR GENERAL CONFORMANCE WITH COUNTY DESIGN CRITERIA. THE COUNTY IS NOT RESPONSIBLE FOR THE ACCURACY AND ADEQUACY OF THE DESIGN, DIMENSIONS, AND/OR ELEVATIONS WHICH SHALL BE CONFIRMED AT THE JOB SITE. THE COUNTY THROUGH THE APPROVAL OF THIS DOCUMENT ASSUMES NO RESPONSIBILITY FOR COMPLETENESS AND/OR ACCURACY OF THIS DOCUMENT.

FILED IN ACCORDANCE WITH THE REQUIREMENTS OF THE EL PASO COUNTY LAND DEVELOPMENT CODE, DRAINAGE CRITERIA MANUAL, VOLUMES 1 AND 2, AND ENGINEERING CRITERIA MANUAL AS AMENDED.

IN ACCORDANCE WITH ECM SECTION 1.12, THESE CONSTRUCTION DOCUMENTS WILL BE VALID FOR CONSTRUCTION FOR A PERIOD OF 2 YEARS FROM THE DATE SIGNED BY THE EL PASO COUNTY ENGINEER. IF CONSTRUCTION HAS NOT STARTED WITHIN THOSE 2 YEARS, THE PLANS WILL NEED TO BE RESUBMITTED FOR APPROVAL, INCLUDING PAYMENT OF REVIEW FEES AT THE PLANNING AND COMMUNITY DEVELOPMENT DIRECTORS DISCRETION.

JENNIFER IRVINE, P.E. DATE
COUNTY ENGINEER / ECM ADMINISTRATOR

TIMING: JULY 2020
ANTICIPATED STARTING AND COMPLETION TIME PERIOD OF SITE GRADING: SEPT 2021
EXPECTED DATE ON WHICH THE FINAL STABILIZATION WILL BE COMPLETED: ~14 AC
AREAS TOTAL AREA OF THE SITE TO BE CLEARED, EXCAVATED OR GRADED:
RECEIVING WATERS: SAND CREEK



CLAREMONT BUSINESS PARK FILING NO. 3

COUNTY OF EL PASO, STATE OF COLORADO

GRADING AND EROSION CONTROL PLAN

MARKSHEFFEL ROAD
(ROW VARIES)
REC. NO. 202028680

U.S. HIGHWAY 24
(ROW VARIES)
REC. NO. 202028680



ADDITIONAL NOTES:
STAGING, STORAGE AND STOCKPILE AREAS TO BE DETERMINED BY CONTRACTOR IN THE FIELD. THE LOCATIONS SHALL BE DELINEATED ON THIS PLAN BY THE CONTRACTOR.
THE EROSION CONTROL DELINEATED ON THIS PLAN SHALL BE REGULARLY UPDATED BY THE CONTRACTOR.

CONSTRUCTION NOTES:
NO WETLANDS ARE TO BE PERMANENTLY DISTURBED PER THIS GRADING PLAN.

CLAREMONT BUSINESS PARK FILING NO. 1C
REC. NO.

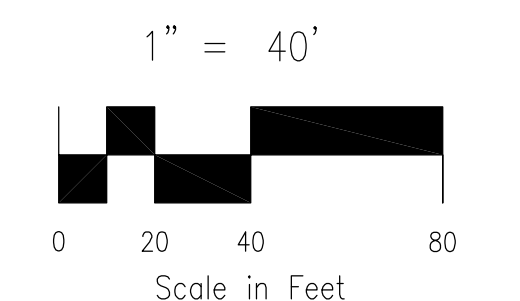

GRADING & EROSION CONTROL PLAN
CLAREMONT BUSINESS PARK FIL. NO. 3
JOB NO. 44-037
DATE PREPARED: APRIL 28, 2020
DATE REVISED: JUNE 29, 2020

EL PASO COUNTY FILE NO. SP 197



102 E. Pikes Peak Ave., 5th Floor
Colorado Springs, CO 80903
PHONE: 719.555.5485

PADMARK BUSINESS PARK FILING NO. 1
REC. NO. 217714046

Concrete Washout Area (CWA) MM-1

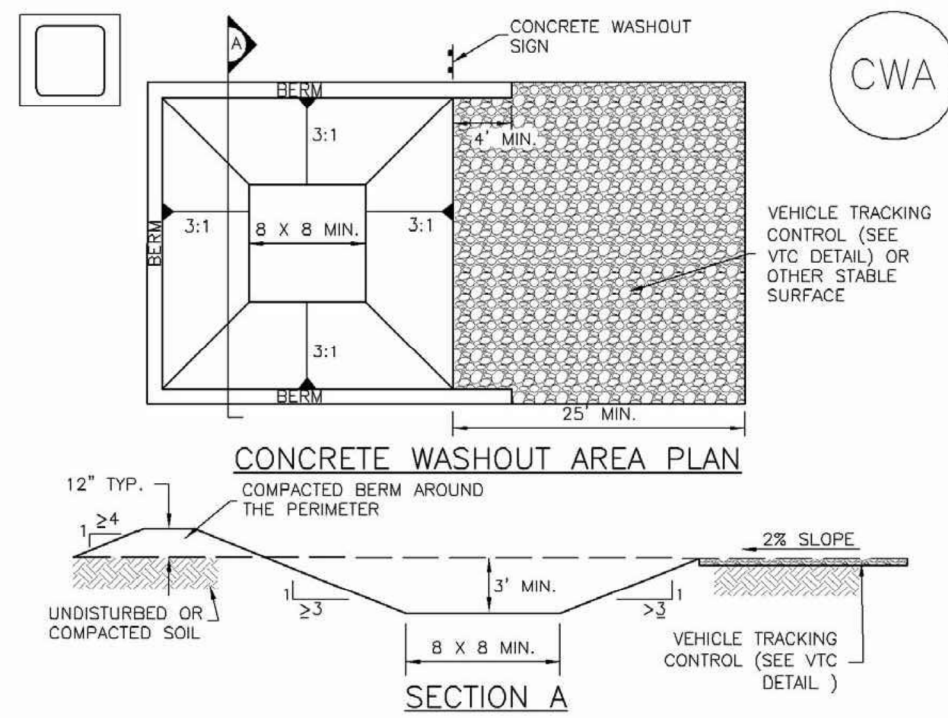

CWA-1. CONCRETE WASHOUT AREA

CWA INSTALLATION NOTES

- SEE PLAN VIEW FOR: -CWA INSTALLATION LOCATION.
- DO NOT LOCATE AN UNLINED CWA WITHIN 400' OF ANY NATURAL DRAINAGE PATHWAY OR WATERBODY. DO NOT LOCATE WITHIN 1000' OF ANY WELLS OR DRINKING WATER SOURCES. IF SITE CONSTRAINTS MAKE THIS INFESIBLE, OR IF HIGHLY PERMEABLE SOILS EXIST ON SITE, THE CWA MUST BE INSTALLED WITH AN IMPERMEABLE LINER (18 MIL MIN. THICKNESS) OR SURFACE STORAGE ALTERNATIVES USING PREFABRICATED CONCRETE WASHOUT DEVICES OR A LINED ABOVE GROUND STORAGE ARE SHOULD BE USED.
- THE CWA SHALL BE INSTALLED PRIOR TO CONCRETE PLACEMENT ON SITE.
- CWA SHALL INCLUDE A FLAT SUBSURFACE PIT THAT IS AT LEAST 8' BY 8' SLOPED LEADING OUT OF THE SUBSURFACE PIT SHALL BE 3:1 OR FLATTER. THE PIT SHALL BE AT LEAST 3' DEEP.
- BERM SURROUNDING SIDES AND BACK OF THE CWA SHALL HAVE MINIMUM HEIGHT OF 1'.
- VEHICLE TRACKING PAD SHALL BE SLOPED 2% TOWARDS THE CWA.
- SIGNS SHALL BE PLACED AT THE CONSTRUCTION ENTRANCE, AT THE CWA, AND ELSEWHERE AS NECESSARY TO CLEARLY INDICATE THE LOCATION OF THE CWA TO OPERATORS OF CONCRETE TRUCKS AND PUMP TRIS.
- USE EXCAVATED MATERIAL FOR PERIMETER BERM CONSTRUCTION.

Vehicle Tracking Control (VTC) SM-4

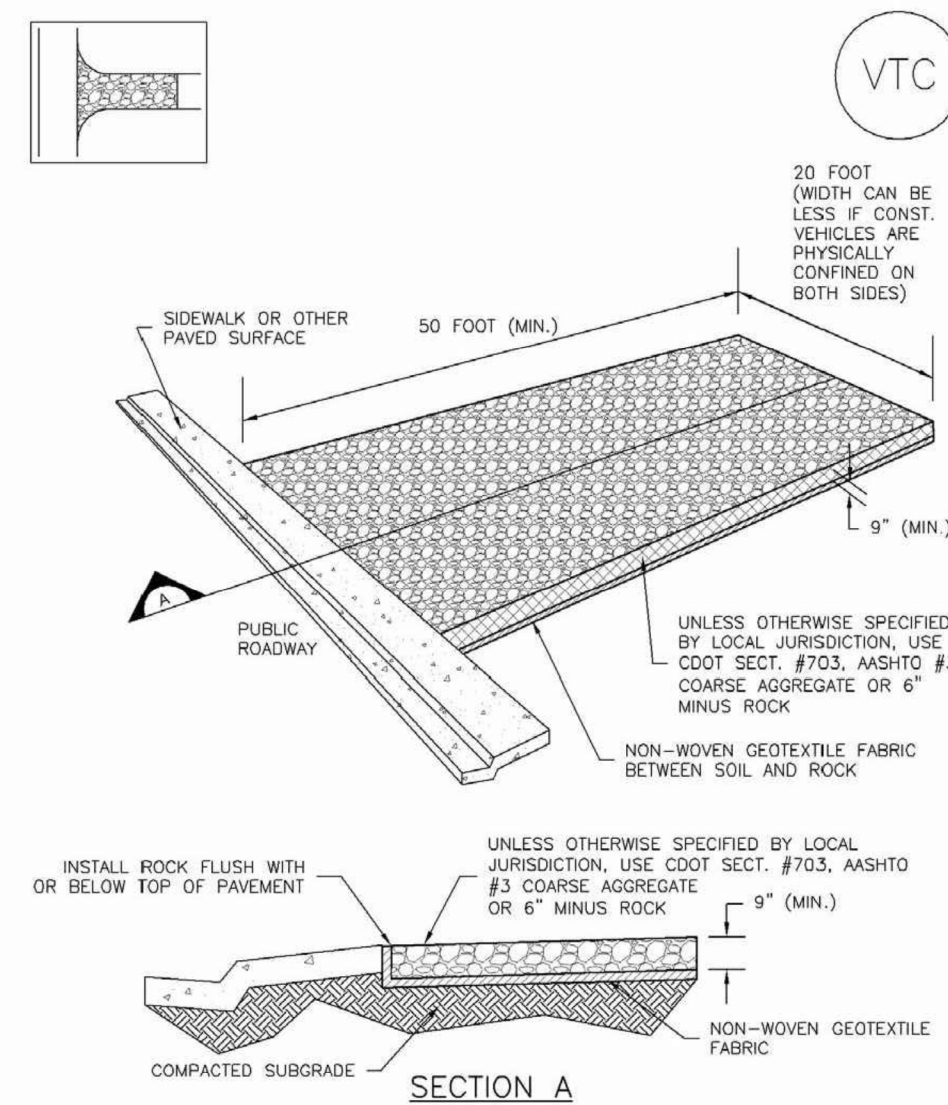

VTC-1. AGGREGATE VEHICLE TRACKING CONTROL

Silt Fence (SF) SC-1

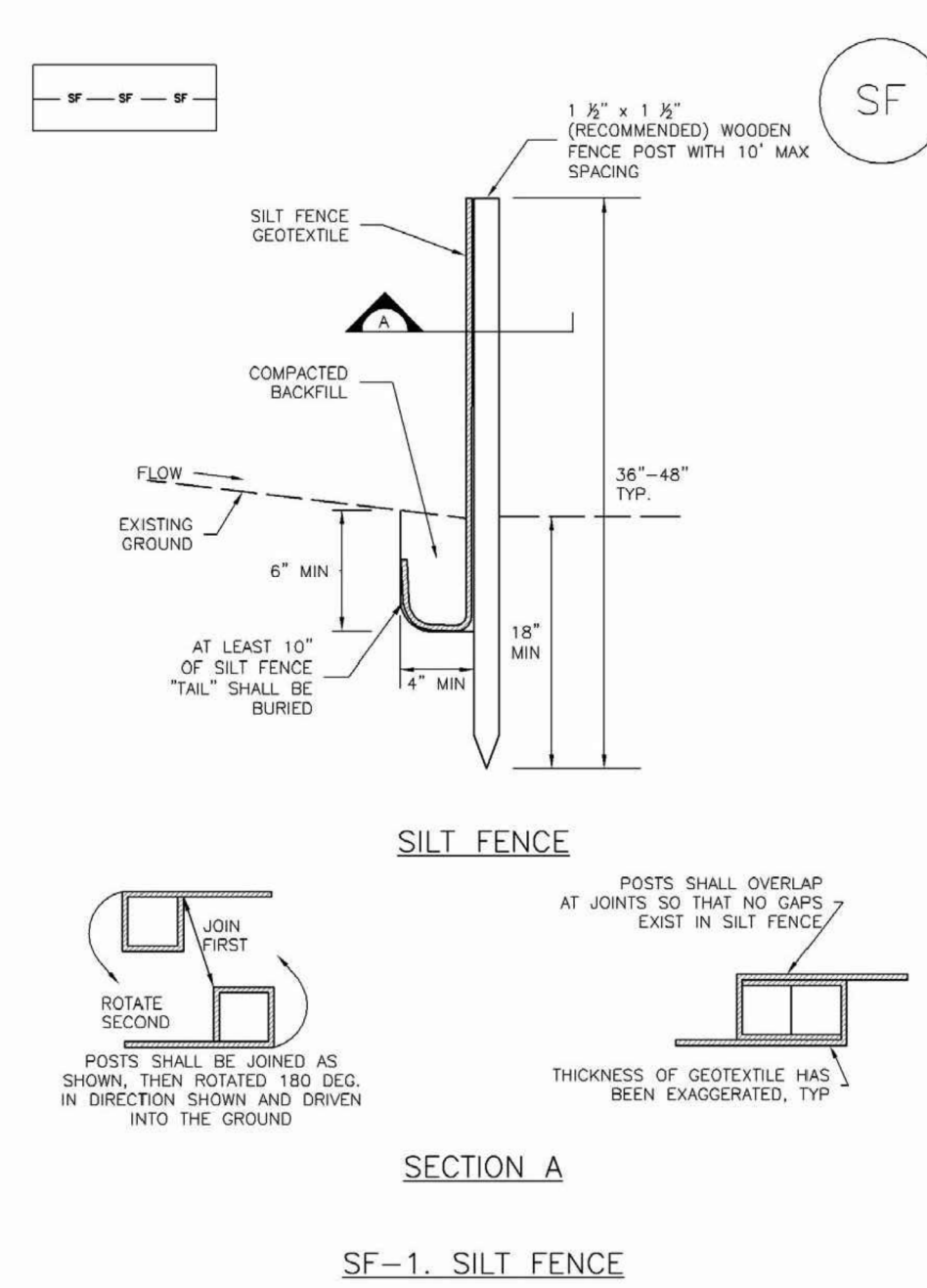

SF-1. SILT FENCE

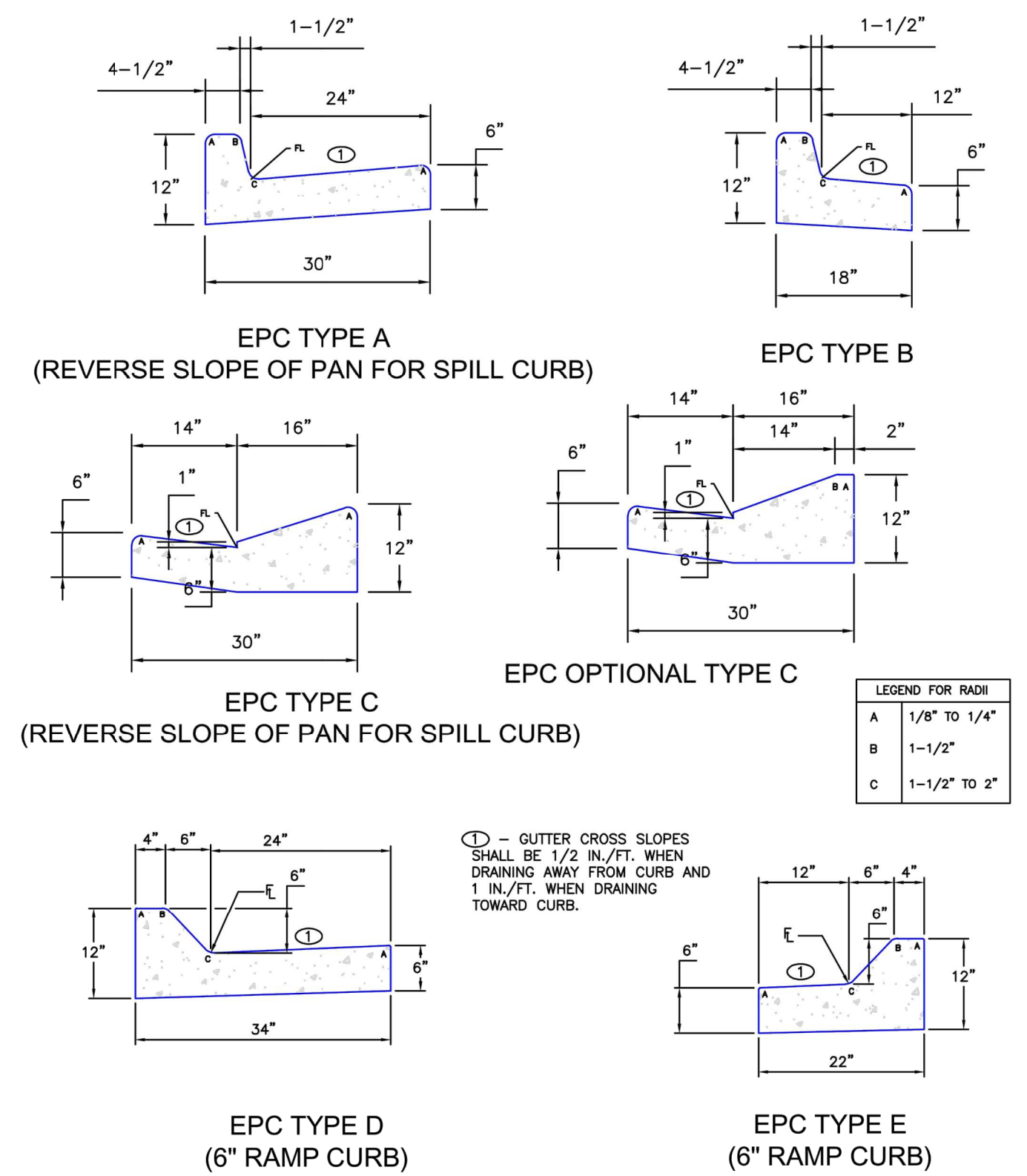

SCALE: NOT TO SCALE

EC-2 Temporary and Permanent Seeding (TS/PS)

Table TS/PS-2. Minimum Drill Seeding Rates for Perennial Grasses

Common Name	Botanical Name	Growth Season	Growth Form	Seeds/Pound	Pounds of PLS/acre
Alkali Soil Seed Mix					
Alkali sycamore	<i>Sporobolus airoides</i>	Cool	Bunch	1,750,000	0.25
Basin wildrye	<i>Elymus cinereus</i>	Cool	Bunch	165,000	2.5
Solar streambank wheatgrass	<i>Agropyron spicatum 'Solar'</i>	Cool	Sod	170,000	2.5
Tose tall wheatgrass	<i>Agropyron elongatum 'Tose'</i>	Cool	Bunch	79,000	7.0
Armba western wheatgrass	<i>Agropyron smithii 'Armba'</i>	Cool	Sod	110,000	5.5
Total					17.75
Fertile Loamy Soil Seed Mix					
Ephraim crested wheatgrass	<i>Agropyron cristatum 'Ephraim'</i>	Cool	Sod	175,000	2.0
Dural hard fescue	<i>Festuca ovina 'darkoccida'</i>	Cool	Bunch	565,000	1.0
Lincoln smooth brome	<i>Bromus inermis leysii 'Lincoln'</i>	Cool	Sod	130,000	3.0
Solar streambank wheatgrass	<i>Agropyron spicatum 'Solar'</i>	Cool	Sod	170,000	2.5
Armba western wheatgrass	<i>Agropyron smithii 'Armba'</i>	Cool	Sod	110,000	7.0
Total					15.5
High Water Table Soil Seed Mix					
Meadow foxtail	<i>Alopecurus pratensis</i>	Cool	Sod	900,000	0.5
Redtop	<i>Agrostis alba</i>	Warm	Open sod	5,000,000	0.25
Reed canarygrass	<i>Phalaris arundinacea</i>	Cool	Sod	68,000	0.5
Lincoln smooth brome	<i>Bromus inermis leysii 'Lincoln'</i>	Cool	Sod	130,000	3.0
Puffblower switchgrass	<i>Panicum virgatum 'Puffblower'</i>	Warm	Sod	389,000	1.0
Albar tall wheatgrass	<i>Agropyron elongatum 'Albar'</i>	Cool	Bunch	79,000	5.5
Total					10.75
Transition Turf Seed Mix					
Ruebens Canadian bluegrass	<i>Poa compressa 'Ruebens'</i>	Cool	Sod	2,500,000	0.5
Dural hard fescue	<i>Festuca ovina 'darkoccida'</i>	Cool	Bunch	565,000	1.0
Citation perennial ryegrass	<i>Lolium perenne 'Citation'</i>	Cool	Sod	247,000	3.0
Lincoln smooth brome	<i>Bromus inermis leysii 'Lincoln'</i>	Cool	Sod	130,000	3.0
Total					7.5

Temporary and Permanent Seeding (TS/PS) EC-2

Table TS/PS-2. Minimum Drill Seeding Rates for Perennial Grasses (cont.)

Common Name	Botanical Name	Growth Season	Growth Form	Seeds/Pound	Pounds of PLS/acre
Sandy Soil Seed Mix					
Blue grama	<i>Bouteloua gracilis</i>	Warm	Sod-forming bunchgrass	825,000	0.5
Camper little bluestem	<i>Setchellium scoparium 'Camper'</i>	Warm	Bunch	240,000	1.0
Prairie sandreed	<i>Calamagrostis longifolia</i>	Warm	Open sod	274,000	1.0
Sand dropseed	<i>Sporobolus vaginatus</i>	Cool	Bunch	5,298,000	0.25
Vaughn sideoats grama	<i>Bouteloua curtipendula 'Vaughn'</i>	Warm	Sod	191,000	2.0
Armba western wheatgrass	<i>Agropyron smithii 'Armba'</i>	Cool	Sod	110,000	5.5
Total					10.25
Heavy Clay, Rocky Foothill Seed Mix					
Ephraim crested wheatgrass	<i>Agropyron cristatum 'Ephraim'</i>	Cool	Sod	175,000	1.5
Oshe intermediate wheatgrass	<i>Agropyron intermedium 'Oshe'</i>	Cool	Sod	115,000	5.5
Vaughn sideoats grama	<i>Bouteloua curtipendula 'Vaughn'</i>	Warm	Sod	191,000	2.0
Lincoln smooth brome	<i>Bromus inermis leysii 'Lincoln'</i>	Cool	Sod	130,000	3.0
Armba western wheatgrass	<i>Agropyron smithii 'Armba'</i>	Cool	Sod	110,000	5.5
Total					17.5

* All of the above seeding mixes and rates are based on drill seeding followed by crimped straw mulch. These rates should be doubled if seed is broadcast and should be increased by 50 percent if the seeding is done using a Brillion Drill or is applied through hydraulic seeding. Hydraulic seeding may be substituted for drilling only where slopes are steeper than 3:1. If hydraulic seeding is used, hydraulic mulching should be done as a separate operation.
 † See Table TS/PS-3 for seeding dates.
 ‡ If site is to be irrigated, the transition turf seed rates should be doubled.
 § Crested wheatgrass should not be used on slopes steeper than 6H to 1V.
 ¶ Can substitute 0.5 lbs PLS of blue grama for the 2.0 lbs PLS of Vaughn sideoats grama.

SC-6 Inlet Protection (IP)

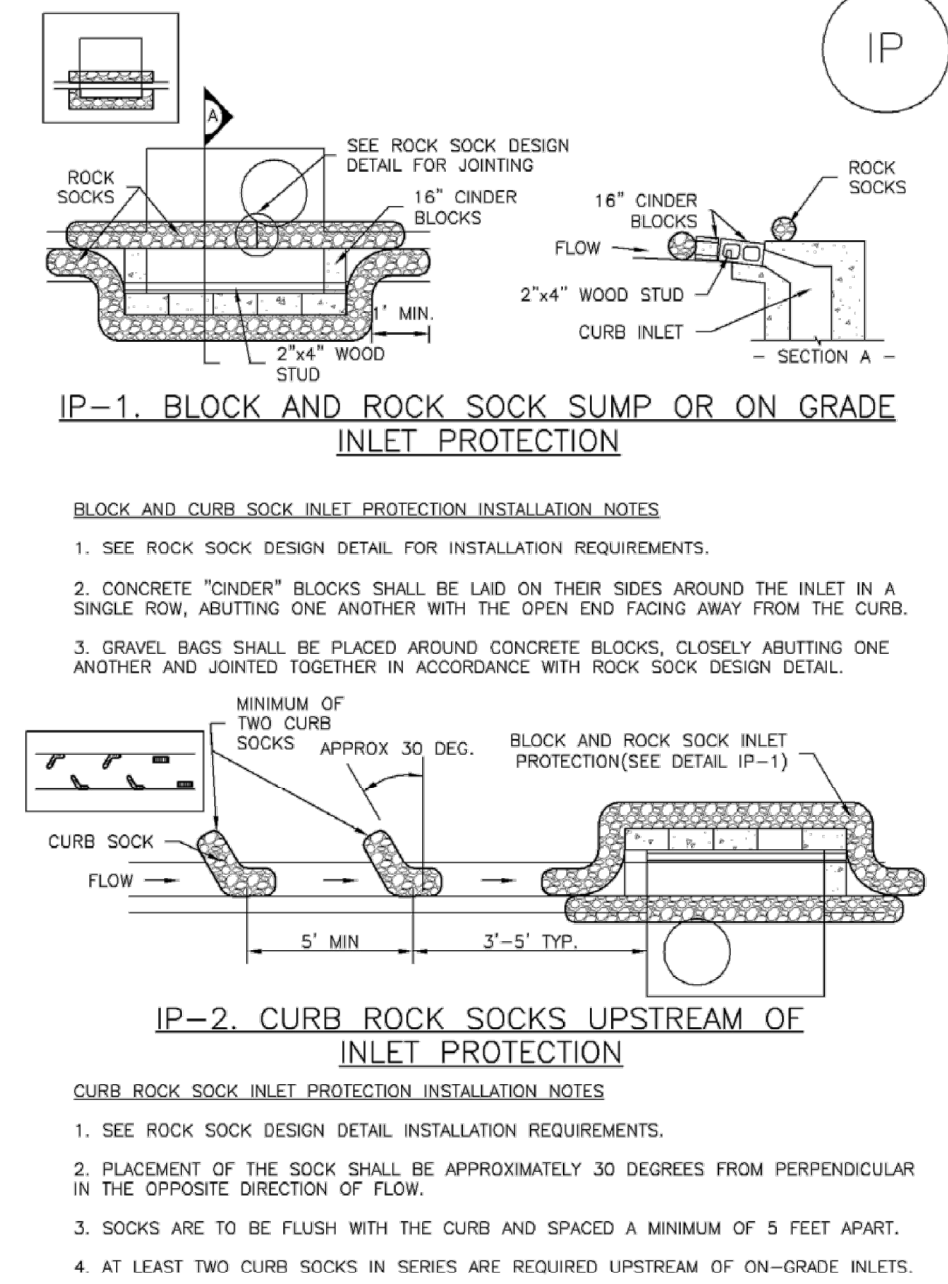

IP-1. BLOCK AND ROCK SOCK SUMP OR ON GRADE INLET PROTECTION

- BLOCK AND CURB SOCK INLET PROTECTION INSTALLATION NOTES**
- SEE ROCK SOCK DESIGN DETAIL FOR INSTALLATION REQUIREMENTS.
 - CONCRETE "CURB" BLOCKS SHALL BE LAID ON THEIR SIDES AROUND THE INLET IN A SINGLE ROW, ABUTTING ONE ANOTHER WITH THE OPEN END FACING AWAY FROM THE CURB.
 - GRAVEL BAGS SHALL BE PLACED AROUND CONCRETE BLOCKS, CLOSELY ABUTTING ONE ANOTHER AND JOINED TOGETHER IN ACCORDANCE WITH ROCK SOCK DESIGN DETAIL.

IP-2. CURB ROCK SOCKS UPSTREAM OF INLET PROTECTION

- CURB ROCK SOCK INLET PROTECTION INSTALLATION NOTES**
- SEE ROCK SOCK DESIGN DETAIL INSTALLATION REQUIREMENTS.
 - PLACEMENT OF THE SOCK SHALL BE APPROXIMATELY 30 DEGREES FROM PERPENDICULAR IN THE OPPOSITE DIRECTION OF FLOW.
 - SOCKS ARE TO BE FLUSH WITH THE CURB AND SPACED A MINIMUM OF 5 FEET APART.
 - AT LEAST TWO CURB SOCKS IN SERIES ARE REQUIRED UPSTREAM OF ON-GRADE INLETS.