

Master Development Drainage Plan &
Preliminary Drainage Report
Monument Ridge East
El Paso County, Colorado

Prepared for:

Monument Ridge East, LLC
5055 List Drive
Colorado Springs, CO 80919
David J Whitehead, P.E.
david@whiteheadengineering.com
(719) 237-4411

Prepared by:
PRC Engineering



1685 W. Uintah St., Suite 114
Colorado Springs, CO 80904
Raymond E. Perez, III, P.E.
(719) 291-2744

SP241

August 5, 2024

ENGINEER'S STATEMENT:

The attached drainage plan and report were prepared under my direction and supervision and are correct to the best of my knowledge and belief. Said drainage report has been prepared according to the criteria established by El Paso County for drainage reports and said report is in conformity with the master plan of the drainage basin. I accept responsibility for any liability caused by any negligent acts, errors, or omissions on my part in preparing this report.



Signature: _____ Date: 08-05-24

Raymond Perez
Registered Professional Engineer State of Colorado
No. 37173

DEVELOPER'S STATEMENT:

I, the owner/developer, have read and will comply with all of the requirements specified in this drainage report and plan.

Name of Owner/Developer: **Monument Ridge East, LLC**

Authorized Signature: _____ Date: _____

Title: Owner

Address: 5055 List Drive
Colorado Springs, CO 80919

EL PASO COUNTY:

Filed in accordance with the requirements of the Drainage Criteria Manual, Volumes 1 and 2, El Paso County Engineering Criteria Manual and Land Development Code as amended.

County Engineer – **Joshua Palmer, P.E.**

Date

Conditions:

Contents

I. INTRODUCTION	2
A. Purpose	2
B. Related Investigations	2
C. Stakeholder Process	2
D. Agency Jurisdictions	2
E. General Project Description.....	2
F. Data Sources	3
G. Applicable Criteria and Standards	4
II. PROJECT CHARACTERISTICS	4
A. Drainage Basin Planning Study Compliance.....	4
B. Land Features.....	4
C. Existing and Proposed Land Uses.....	5
III. HYDROLOGIC ANALYSIS	5
A. Methodology.....	5
B. Basin Hydrology – Existing Conditions.....	6
C. Basin Hydrology – Developed Conditions.....	8
D. Water Quality – 4 Step Process	19
E. Water Quality Improvements	20
IV. HYDRAULIC ANALYSIS.....	20
V. ENVIRONMENTAL EVALUATIONS	20
A. Wetland and Riparian Areas.....	20
B. Stormwater Quality	20
C. Permitting Requirements.....	21
VI. ALTERNATIVES EVALUATION.....	21
VII. SELECTED PLAN (IMPLEMENTATION OF THE MASTER PLAN)	21
A. Plan Hydrology	21
B. System Improvements.....	21
C. System Priorities/Phasing.....	21
D. Deficiency Costs	22
E. Reimbursable Costs.....	22
F. Governing Agencies Requirements	22

G. Maintenance Requirements22

H. Implementation Recommendation23

I. Grading and Erosion Control Plans23

VIII. FEE DEVELOPMENT23

IX. SUMMARY.....23

X. REFERENCES23

XI. APPENDICES24

A. Stakeholder Meeting Summary24

B. Hydrology.....24

C. Hydraulics – Pipes, Inlets and Ponds24

D. Drainage Maps.....24

Appendix A – Maps

- NRCS Soils Map
- FEMA Flood Insurance Rate Map (Firmette)

Hydraulic

- Inlets
- Culvert
- Pipe

Appendix B – Calculations

Hydrologic

- Percent Impervious
- Composite Runoff Coefficients
- Basin Runoff Summary
- Surface Routing Summary

Water Quality

- Extended Detention Basin

Appendix C – Drainage Maps
(located in report pocket)

- Existing Conditions
- Developed Conditions – Overall
- Developed Conditions - Site

I. INTRODUCTION

A. Purpose

The purpose of this Master Development Drainage Plan & Preliminary Drainage Report for the Monument Ridge East (hereinafter referred to as the “Project”) is to identify major drainageways, detention areas, locations of culverts, open channels and drainage areas contained within and adjacent to the proposed development and quantify and evaluate the impacts of stormwater runoff generated by this project and to provide adequate water quality/detention treatment and flow conveyance.

B. Related Investigations

The Monument Ridge East project is adjacent to the Misty Acres development. The Misty Acres development area has been studied in the past since 2001. There is no known master drainage study on file that encompasses the entire project area (Bald Mountain watershed). Refer to the references listing for Misty Acres development record reports used.

C. Stakeholder Process

To date, there has not been any public outreach or stakeholder engagement for the project. This phase of project development will run concurrently with the Development Plan process.

D. Agency Jurisdictions

This project is located within El Paso County and is subject to the design criteria set forth in the City of Colorado Springs Drainage Criteria Manual, Volumes I and II, dated May 2014 (rev. 2021) (DCM) and the El Paso County Drainage Criteria Manual Volume 1 Updates.

E. General Project Description

This project is in El Paso County, Colorado. Access to the site is from Palmer Divide Road (aka – County line road). It is located in Section 2, Township 14 south, Range 67 west of the 6th Principal Meridian. A vicinity map is provided below in Figure 1.

Figure 1 – Vicinity Map
(Source: Google Earth Imagery 2019)

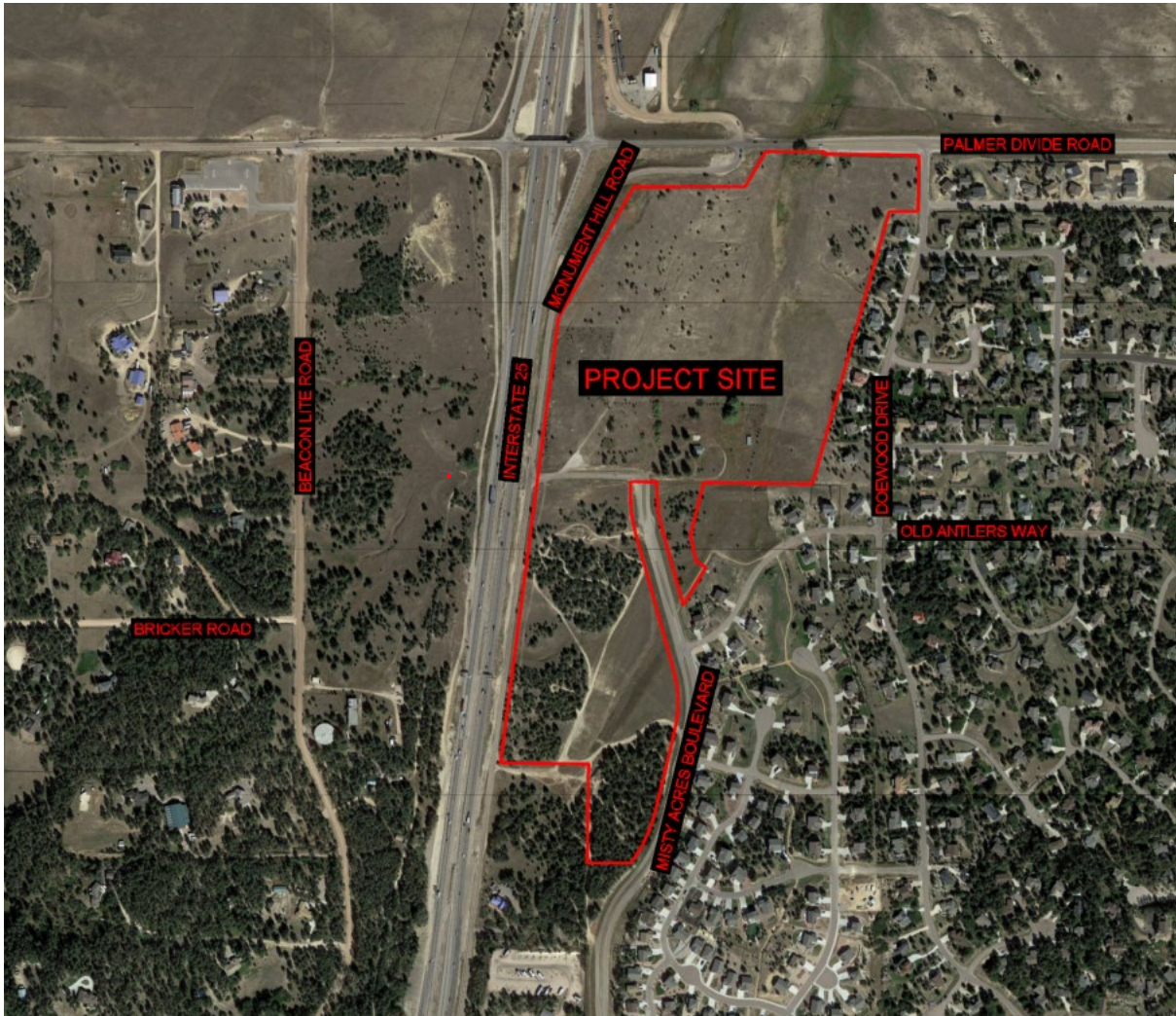

The Project is a 65-acre single-family development. The project will consist of single-family homes and associated site elements typical of residential development (e.g. – roadways, buildings, walkways, parks/open space, detention/water quality ponds etc.) The proposed development area is currently vacant. The site is bounded by the north by existing Palmer-Divide Road to the east by Doewood Drive and Misty Acres Boulevard, to the west by Interstate 25.

F. Data Sources

General

The base mapping (including topography) and structure inventory was provided by Bear Creek Surveying, Inc. (now Colorado ILC Surveying). The field survey was

conducted in the fall of 2022. To date there have been no environmental or geotechnical studies performed for the Project. Soils information is provided in section II.B. Additional topography for areas outside of the topographic survey was obtained from the Colorado Water Conservation Board (CWCB). CWCB topography consists of Digital Elevation Model (DEM) 2ft contours and 5ft contours. The 2' contours were used for off-site basin delineation. The 5ft contours were used in the drawings for the “overall” mapping.

G. Applicable Criteria and Standards

The hydrologic and hydraulic analysis performed in this report utilizes The City of Colorado Springs Drainage Criteria Volumes 1 (revised January 2021) & 2 (revised December 2020), hereinafter referred to as the CSDCM. In addition to the City Criteria Manual, the Urban Storm Drainage Criteria Manual (USDCM), Volumes 1-3, published by the Mile High Flood District (MHFD), latest update, have been used to supplement the Drainage Criteria Manual for water quality capture volume (WQCV). Also, the El Paso County Drainage Criteria Manual volume 1 updates were incorporated. Stormwater runoff was determined using the Rational Method and was calculated for existing and proposed conditions for the 10-yr (minor) and 100-yr (major) recurrences.

II. PROJECT CHARACTERISTICS

A. Drainage Basin Planning Study Compliance

There is no Drainage Basin Planning Study of record that encompasses this project. All developed runoff from the site will be detained and released at pre-development peak rates, and the water quality capture volume will be treated. Detention and water quality were determined by the MHFD detention spreadsheet UD-Detention v4.04.

B. Land Features

1. Geology

The majority of the site is currently undeveloped and consists of natural vegetative land cover with the exception of existing Misty Acres Boulevard (major arterial roadway) which essentially bisects the property. There were no pronounced geological features discovered during any of the site visits.

2. Vegetation

Ground cover primarily consists of bare ground, sparse vegetation, and trees.

3. Soils

The general topography of the land slopes to the north. According to the Natural Resources Conservation Service (NRCS), the soils in this area can be classified as a Hydrologic Soil Group (HSG) Types B and D. This is used to predict storm water runoff rates. A soils report and map describing the HSG's and other soils properties are provided in Appendix A. For the purposes of this report each basin defined has had runoff coefficients adjusted accordingly using the soils report and map.

4. Environmental

To date there has not been any environmental site evaluations conducted with the exception of wetlands delineation (refer to drainage map for delineation boundaries). Endangered species, groundwater determination, etc. will be performed at a later date. Information found within those studies will be included in future Monument Ridge East Final Drainage Report (FDR) documentation.

5. Water Quality

There are no known existing water quality features located on the property.

6. Floodplain

Per the Flood Insurance Rate Map Numbers 08041C0065G and 0804C0276G, El Paso County, Colorado, Revised December 7, 2018, Federal Emergency Management Agency (FEMA) no portion of Monument Ridge East lies within the designated 100year floodplain. A FIRMet of the project area is included in Appendix A.

C. Existing and Proposed Land Uses

Presently, the site is unplatted and consists of undeveloped land. Monument Ridge East is a proposed single-family residential development with associated streets and detention/water quality ponds.

III. HYDROLOGIC ANALYSIS

A. Methodology

1. Method of Analysis

Storm sewer sizing for this project uses the Rational Method as recommended by the DCM for the minor (10 year) and major (100 year) storms for drainage basins less than 100-acres in size.

The Rational Method uses the following equation:

$$Q=C*I*A$$

Where:

Q = Maximum runoff rate in cubic feet per second (cfs)

C = Runoff coefficient

I = Average rainfall intensity (inches/hour)

A = Area of drainage sub-basin (acres)

2. Runoff Coefficient

Coefficients from Table 6-6 of the EPC DCM Volume 1 update for developed land were utilized in the Rational Method calculations. See Appendix B for more information.

3. Time of Concentration

The time of concentration consists of the initial time of overland flow and the travel time in a hydraulic conveyance feature to a design point or similar location of interest. A minimum time of concentration of 5 minutes is utilized for urban development.

4. Rainfall Intensity

The hypothetical rainfall depths for the 1-hour storm duration were taken from Table 6-2 of the Colorado Springs Drainage Criteria Manual.

B. Basin Hydrology – Existing Conditions

This project is located in the Bald Mountain major drainage basin. It is our understanding there is no Drainage Basin Planning Study (DBPS) on file that encompasses this project. Therefore, this project area is considered unstudied from a master drainage analysis perspective.

Stormwater runoff from the project generally flows to the north, and ultimately discharges into an unnamed drainage way. Eleven (11) basins were delineated for this analysis. Refer to the existing conditions map in Appendix D.

Design Point 1 flows are generated from basin E2. Basin E2 consists of a portion of a single-family home site and undeveloped land. Runoff from this basin travels overland easterly to an existing 36" RCP which outfalls on the east side of Interstate 25 into basin E1. Runoff will then travel easterly via a broad grass lined swale towards Design Point 2.

Design Point 2 flows are generated from basin E1. Basin E1 consists of undeveloped land with a few informal gravel roadways and paths. Runoff from this

basin travels overland northeasterly to existing dual 48" RCP's which routes flow under Misty Acres Boulevard and to east side into basin E3. Runoff will then travel northeasterly via a broad grass lined swale towards Design Point 3.

Design Point 3 flows are generated from Design Point 2 runoff and basin E3. Basin E3 consists of a portion of a single-family home sites and undeveloped land. Runoff from this basin travels overland northerly to an existing detention pond (design/approved under EDARP Filing No. SF01016) as part of the Misty Acres Filing No. 1 development. This pond serves as detention for the Misty Acres Filing No. 1 development as well as a portion of the project west of Misty Acres Boulevard. The pond outfalls with a 48" RCP to the north into basin E7. Runoff then travels north via a broad grass lined swale towards Design Point 6.

Design Point 4 flows are generated from basin E4. Basin E4 consists of single-family home sites. Runoff from this basin travels overland northwesterly to an existing pond facility (design/approved under EDARP Filing No. SF94003) that does not appear to provide a significant amount of detention as no outlet works are present. Therefore, no peak attenuation or water quality is provided. The pond outfalls to the north into basin E5. Runoff then travels northwesterly via a grass lined swale towards Design Point 5. The pond facility will be remain in place without any modification.

Design Point 5 flows are generated from Design Point 4 runoff and basin E5. Basin E5 consists of single-family home sites. Runoff from this basin travels northwesterly via a grass lined swale to dual 48" CMP's under Doewood Drive to the project's east boundary line. Runoff then travels northwesterly via a broad grass lined swale towards Design Point 6.

Design Point 6 flows are generated from Design Point 3 and Design Point 5 runoff and basin E7. Basin E7 consists of undeveloped land. Runoff from this basin travels overland northerly to an existing wetlands depression area south of and adjacent to the Palmer-Divide Road. During the minor and major storm events, flows overtop the roadway with the single 48" CMP.

Design Point 7 flows are generated from basin E8. Basin E8 consists of undeveloped land and large lot single family development as well as a portion of Interstate 25. Runoff from this basin travels overland easterly to an existing 48" CMP which outfall on the east side of Interstate 25 into basin E10. Runoff will then travel northerly via a broad grass lined swale towards Design Point 8.

Design Point 8 flows are generated from Design Point 7 runoff and basin E9 & E10. Basin E9 consists of Interstate 25 and Monument Hill Road. Runoff from this basin travels via a roadside swale northerly to an existing grated inlet constructed with the Interstate 25 express lane project. Flow is captured in this inlet and combines with runoff from basin E8 and outfalls on the east side of Monument Hill Road into basin E10. Basin E10 consists of Monument Hill Road and undeveloped land. Runoff then travels northeasterly via a broad grass lined swale to Design Point 8. Flow is conveyed under Monument Hill Road via an existing 48" RCP towards Design Point 9. It is noteworthy to mention that at this location it is difficult to determine if there is enough head for all of the flow to enter this culvert. The same holds true at Design Point 9. Additional survey data will be gathered prior to Final Drainage Report analysis.

Design Point 9 flows are generated from basin E11. Basin E11 consists of Interstate 25, an off-ramp and interchange gore areas. Runoff from this basin travels overland northeasterly via a broad grass lined swale to an existing 48" RCP which outfalls on the north side of Palmer Divide Road. It is noteworthy to mention that additional survey data is needed to determine if there is enough head to prevent flows from routing easterly. Regrading the swale to the west may be necessary which will be determined during the construction document preparation phase.

Design Point 10 is shown to represent where runoff from single-family residential home sites east of basins E4, E5 and E6 crosses over the Palmer Divide roadway. Field evidence reveals a roadside swale on the south side of Palmer Divide Road that has very little capacity as it approaches Doewood Drive. Under Doewood Drive, there is an existing 24" RCP that seems to convey flow only from basin E6. Basin E6 consists of single-family residential development. The amount of flow anticipated from the east side of the projects study is assumed to be very large. Due to the current swale geometry and grades at the Doewood intersection, it is assumed the runoff overtops Palmer Divide Road during even minor storm events and is directed to the north. For this reason, no anticipated flow besides that of basin E6 is anticipated to enter into basin E7.

C. Basin Hydrology – Developed Conditions

Stormwater runoff from the project generally flows to the north, and ultimately discharges into a wetlands depression area south of and adjacent to Palmer Divide Road. Proposed grading of the site will generate twenty-three (23) on-site basins and fourteen (14) off-site basins. Please note that the Design Points numbers change when referenced in the proposed condition for ease of review. Refer to the developed conditions map in Appendix D. All proposed storm piping, inlets and manholes within public right-of-way be publicly owned and maintained. All other

proposed storm system elements will be privately owned and maintained. All public storm pipes will be RCP.

For the purposes of this report, generic descriptions of “pipe” and “inlets” have been referenced instead of using detailed descriptions (e.g. – “pipe 8” or “proposed 8’ at-grade inlets”). Refer to the drainage maps, tables and calculations to provide more details as to what the system is composed of. The following basin descriptions are intended to provide general routing guidance only. Additionally, it is noteworthy to mention that at all inlet locations for this project (sump or at-grade), flows are captured in their entirety, i.e. – no flowby. Due to the steep grades of all roadways being proposed, sump inlet locations are not able to be sited in most situations.

A groundwater determination has been made and it appears that there are areas on site in locations where ponds will be built which have shallow groundwater. Per CDHPE “Low Risk Discharge Guidance – Discharges of Uncontaminated Groundwater to Land” discharging groundwater to a pond is prohibited. Permits to do so can be found on the CDPHE web site. Mitigation is another option which can be implemented in the form of an impervious synthetic liner or clay liner. This will be determined during the FDR preparation phase.

Design Point 11 flows are generated from basin O1. Basin O1 consists of primarily undeveloped land with one home site. Per the Misty Acres drainage reports, this land will be required to detain runoff to historic levels upon development. For this reason, the basin runoff has been accommodated to flow through the project site at a historic rate. Runoff from this basin is routed via a proposed pipe to design point 19.

Design Point 12 flows are generated from basin O2. Basin O2 consists of Interstate 25 and Monument Hill Road. Runoff from this basin travels east and is captured by a CDOT grated inlet located in the swale adjacent to the roadway. The flow is captured by the inlet and is routed to the east side of Monument Hill Road via a 36” RCP pipe. It is unknown as to why this pipe is so large considering the basin area is so small and is located near the high point of Interstate 25. Flows are then routed overland and enter the street. Flows then proceed via curb and gutter easterly within basin A1 towards Design Point 13.

Design Point 13A flows are generated from a portion of basin A1. Basin A1 consists of single-family tri-plex home sites. Runoff from this basin travels via curb and gutter towards Design Point 13A where they are captured by a proposed inlet. Flows are then conveyed via a pipe system and are routed to Design Point 1B.

Design Point 13B flows are generated from a portion of basin A1. Basin A1 consists of single-family tri-plex home sites. Runoff from this basin travels via curb and gutter towards Design Point 13B where they are captured by a proposed inlet. Flows are then conveyed via a pipe system and are routed to Design Point 18.

Design Point 14 flows are generated from basin A2. Basin A2 consists of single family tri-plex home sites. Runoff from this basin travels via curb and gutter to Design Point 14 where they are captured by two proposed inlets. Flows are then conveyed via a pipe system and combine with flows from Design Point 13B. They are then routed to Design Point 18.

Design Point 15 flows are generated from basin O3. Basin O3 is the same as basin E2 consisting of a single lot and undeveloped land on the west side of the interstate. Runoff from this basin travels east via an existing 36" RCP connecting to an existing CDOT grated inlet at Design Point 16.

Design Point 16 flows are generated from basin O4. Basin O4 consist of Interstate 25 and Monument Hill Road. Runoff from this basin travels easterly to a proposed storm pipe located within basin A4 at Design Point 17. Flow is then routed to Design Point 18 via a pipe system.

Design Point 17 flows are generated from basin O4. Runoff from this basin travels easterly after entering a proposed end section to via a proposed storm pipe towards Design Point 18.

Design Point 18 is located where flows from aforementioned Design Points combine and are routed via a proposed storm pipe towards the culvert system which outfalls into pond 1.

Design Point 19 flows are generated from basins O1 and A3. Basin O1 has been described above under Design Point 11 with pipe outfalling into the depression area described below. Basin A3 consists of single-family tri-plex home sites and open space. Runoff from basin A3 travels to a proposed culvert at Design Point 19 and is routed north under the road via a culvert into proposed pond 1 after collecting in a depression area.

Design Point 20 flows are generated from basin A4. Basin A4 consists of single-family duplex and tri-plex home sites. Runoff from this basin travels to a proposed low point where it will be captured by two sump inlets. Flows from this point will be routed to the north to pond 1.

Design Point 21 is located at the outfall of the storm sewer system described above under Design Point 18.

Design Point 22 flows are generated from Design Point 19, 20 and 21 runoff. Basin A5 consists of pond 1 itself. For the purpose of this report, a detailed pond design was not conducted as indicated above. This will be provided in future FDR's. As such, the MHFD UD-Detention spreadsheet was used for preliminary sizing. A private full spectrum extended detention basin (EDB) is proposed at this location. The proposed on-site imperviousness contributing to this pond has been calculated to be 45.60%. The ponds' tributary area equals 24.52 acres. The pond facility will provide ~2.1acre-ft of detention volume and ~0.4acre-ft of WQCV. The EDB will have forebays, a maintenance access road, concrete trickle channel, micro pool and an outlet structure retrofitted at the end of one of the existing 48" culverts under Misty Acres Boulevard. The other 48" culvert will be capped on each end and abandoned. The full-spectrum EDB will have a rip rap emergency overflow spillway that will drain the 100yr peak flows in the event the outlet structure becomes entirely clogged and another 100yr event passes. The spillway will be constructed of soil rip rap. A minimum of 1.0' of freeboard will be provided. The spillway will be situated such that any overflow will be directed to a low point in Misty Acres Boulevard, Design Point 27. Refer to the design calculations in Appendix B for additional pond design information.

Design Point 23 flows are generated from basin B1. Basin B1 consists of single-family duplex home sites. Runoff from this basin travels north via curb and gutter to two proposed sump inlets mid-block. Flows are then routed via a pipe to Design Point 26.

Design Point 24 flows are generated from basin B2. Basin B2 consists of single-family duplex home sites. Runoff from this basin travels north via curb and gutter to a proposed triple type R inlet where flow is captured. Flows are then routed via pipe towards Design Point 26.

Design Point 25 flows are generated from basin B3. Basin B3 consists of single-family duplex home sites. Runoff from this basin travels north via curb and gutter to a proposed triple type R inlet where flow is captured. Flows are then routed via pipe to Design Point 24 and then north to Design Point 26.

Design Point 26 is located where flows from Design Points 23, 24 and 25 combine and are routed via a proposed storm pipe towards the pipe system in Misty Acres Boulevard which outfalls into pond 2.

Design Point 27 flows are generated from basin B8. Basin B8 consists of open space and portion Misty Acres Boulevard. Runoff from this basin travels to a proposed low point where it will be captured by two sump inlets. Flows from this location will be routed to the north to Design Point 28. In the event clogging occurs, flow will overtop the roadway and enter the Misty Acres pond

Design Point 28 flows are generated from a portion of basin B4. Basin B4 consists of open space and the adjacent roadway. Runoff from this basin travels easterly via curb and gutter to an inlet where flow is captured. Flows are then routed in a pipe system towards Design Point 29.

Design Point 29A flows are generated from a portion of basin B4. Runoff from this basin travels easterly via curb and gutter to an inlet where flow is captured. Flows are then routed in a pipe system to proposed pond 2.

Design Point 29B is located where the two systems combine. Runoff from this location travels easterly in a pipe system to proposed pond 2.

Design Point 30 flows are generated from a portion of basin B5. Basin B5 consists of single family duplex home sites and open space. Runoff from this basin travels via curb and gutter to Design Point 30 where they are captured by a proposed inlet. Flows are then conveyed via a pipe system and combine with flows from Design Point 31. They are then routed to Design Point 32 via a storm pipe system.

Design Point 31 flows are generated from a portion of basin B5. Runoff from this basin travels via curb and gutter to Design Point 31 where they are captured by a proposed inlet. Flows are then conveyed via a pipe system and combine with flows from Design Point 30. They are then routed to Design Point 32 via a storm pipe system.

Design Point 32 flows are generated from basin B6. Basin B6 consists of single family duplex home sites and open space. Runoff from this basin travels via curb and gutter to Design Point 32 where they are captured by a proposed inlet. Flows

are then conveyed via a pipe system after combining with flows from Design Point 31 to Design Point 33.

Design Point 33 flows are generated from basin B7. Basin B6 consists of single family duplex home sites and open space. Runoff from this basin travels via curb and gutter to Design Point 33 where they are captured by a proposed inlet. Flows are then conveyed via a pipe system to proposed pond 2 after combining with flows from Design Point 32.

Design Point 34 flows are generated from Design Points 29B and 33 runoff and basin B9. Basin B9 consists of pond 2 itself along with open space. For the purpose of this report, a detailed pond design was not conducted. The reasoning for this is that there are no final drainage calculations and construction design documents prepared which would have this level of detail at this time. The FDR will be prepared concurrently when the CD's are completed. This information can and will be provided at that time. As such, the MHFD UD-Detention spreadsheet was used for preliminary sizing. A private full spectrum extended detention basin (EDB) is proposed at this location. The proposed on-site imperviousness contributing to this pond has been calculated to be 57.88%. The ponds' tributary area equals 20.48 acres. The pond facility will provide ~2.1acre-ft of detention volume and ~0.4acre-ft of WQCV. The EDB will have forebays, a maintenance access road, concrete trickle channel, micro pool and an outlet structure. The full-spectrum EDB will have a rip rap emergency overflow spillway that will drain the 100yr peak flows in the event the outlet structure becomes entirely clogged and another 100yr event passes. The spillway will be constructed of soil rip rap. A minimum of 1.0' of freeboard will be provided. The spillway will be situated such that any overflow will be directed on the north side of the pond such that overflow would be directed north to a low point in Misty Acres Boulevard, Design Point 38. Refer to the design calculations in Appendix B for additional pond design information.

Design Point 35 flows are generated from basin C1. Basin C1 consists of single family duplex home sites and the adjacent roadway. Runoff from this basin travels northeasterly via curb and gutter to Design Point 35 where flow is captured by proposed triple inlets. Flows are then routed in a pipe system to Design Point 36.

Design Point 36 flows are generated from basin C2. Basin C2 consists of single family duplex home sites and the adjacent roadway. Runoff from this basin travels easterly via curb and gutter to an inlet where flow is captured. Flows are then routed in a pipe system to proposed pond 3.

Design Point 37 flows are generated from Design Point 36 runoff and basin C3. Basin C3 consists of pond 3 itself. For the purpose of this report, a detailed pond design was not conducted. As stated above, this will be provided in future FDR's. As such, the MHFD UD-Detention spreadsheet was used for preliminary sizing. A private full spectrum extended detention basin (EDB) is proposed at this location. The proposed on-site imperviousness contributing to this pond has been calculated to be 56.91%. The ponds' tributary area equals 5.61 acres. The pond facility will provide ~0.6acre-ft of detention volume and ~0.1acre-ft of WQCV. The EDB will have forebays, a maintenance access road, concrete trickle channel, micro pool and an outlet structure. The full-spectrum EDB will have a rip rap emergency overflow spillway that will drain the 100yr peak flows in the event the outlet structure becomes entirely clogged and another 100yr event passes. The spillway will be constructed of soil rip rap. A minimum of 1.0' of freeboard will be provided. The spillway will be situated such that any overflow will be directed to the east to a low point in Misty Acres Boulevard, Design Point 38. Refer to the design calculations in Appendix B for additional pond design information.

Design Point 38 is located where flows from ponds 2 and 3 combine. Flows are then routed northerly via a pipe system towards County Line Road. Prior to reaching the intersection, the system directs runoff to the east to Design Point 45.

Design Point 39 flows are generated from basin D1. Basin D1 consists of open space and portion Misty Acres Boulevard. Runoff from this basin travels to a proposed low point where it will be captured by two sump inlets. Flows from this location will be routed to the east to proposed pond 4 at Design Point 41. In the event clogging occurs, flows will overtop the roadway and enter pond 4.

Design Point 40a flows are generated from a portion of basin D2. Basin D2 consists of single-family home sites. Runoff from this basin travels north via curb and gutter to an inlet where flow is captured. Flows are then routed via pipe to Design Point 40b.

Design Point 40b flows are generated from a portion of basin D2. Runoff from this basin travels north via curb and gutter to an inlet where flow is captured. Flows are then routed via pipe to Design Point 40c.

Design Point 40c flows are generated from a portion of basin D2. Runoff from this basin travels north and then west via curb and gutter to two sump inlets where flow is captured. Flows are then routed via pipe to proposed pond 4 (south) at Design Point 41 after combining with flows from Design Point 40b.

Design Point 41 is composed of the southern basin of the pond 4 facility, basin D5. Flow routed to this location will be routed to the north into the upper portion of the pond via a flat 30" pipe thereby combining the two areas into one facility. The connecting pipe is sized such that there is no backwater effect and captured runoff will flow freely to be detained and treated in the north basin. The reason for this approach is due to the existing wetlands adjacent to the pond and the distance from the Misty Acres Boulevard connection to Palmer Divide Road being so close. To minimize wetlands disturbance, the pond has been located along its western edge. This creates a configuration that necessitates two depression areas which as stated above will be connected by a pipe and will function like a normal water quality and detention facility.

Design Point 42 flows are generated from basin D3. Basin D3 consists of a small portion of Misty Acres Boulevard and adjacent open space. This basin has been created to route impervious areas of the roadway improvements to the pond for detention and water quality treatment. Runoff from this basin travels to an inlet where flow will be captured. Flows from this location will be routed to the east to Design Point 43 via a pipe system under Misty Acres Boulevard. The northern portion of basin D3 has minor grading to prevent flow from Design Point 59 to route easterly. Based on the existing topography, at this time flow would not be fully contained in the culvert.

Design Point 43 flows are generated from basin D4. Basin D4 consists of a small portion of Misty Acres Boulevard. Similar to Design Point 42, flows from the roadway are being captured and routed to the pond for detention and water quality treatment.

Design Point 44 flows are generated from Design Points 41 and 43 and basin D5. Basin D5 consists of pond 3 itself. As stated prior, a detailed pond design was not conducted. This will be provided in future FDR's. As such, the MHFD UD-Detention spreadsheet was used for preliminary sizing. A private full spectrum extended detention basin (EDB) is proposed at this location. The proposed on-site imperviousness contributing to this pond has been calculated to be 40.89%. The ponds' tributary area equals 22.74 acres. The pond facility will provide ~1.8acre-ft of detention volume and ~0.4acre-ft of WQCV. The EDB will have forebays, a maintenance access road, concrete trickle channel, micro pool and an outlet structure. The full-spectrum EDB will have a rip rap emergency overflow spillway that will drain the 100yr peak flows in the event the outlet structure becomes entirely clogged and another 100yr event passes. The spillway will be constructed of soil rip rap. A minimum of 1.0' of freeboard will be provided. The spillway will be situated such that any overflow will be directed to a swale that runs along the south side of

Palmer Divide Road, ultimately outfalling into the wetlands depression area. Refer to the design calculations in Appendix B for additional pond design information. Flows released from the pond will be routed to the north into the bypass pipe system at Design Point 45.

Design Point 45 is a junction structure which connects system outflows from ponds 2 and 3 with pond 4. This bypass system outfalls into the wetland depression area.

Design Point 46 flows are generated from basin E. Basin E consists of single family residential home sites as well as pond 5 itself. As stated prior, a detailed pond design was not conducted. This will be provided in future FDR's. As such, the MHFD UD-Detention spreadsheet was used for preliminary sizing. A private full spectrum extended detention basin (EDB) is proposed at this location. The proposed on-site imperviousness contributing to this pond has been calculated to be 48.40%. The ponds' tributary area equals 3.21 acres. The pond facility will provide ~0.3acre-ft of detention volume and ~0.05acre-ft of WQCV. The EDB will have forebays, a maintenance access road, concrete trickle channel, micro pool and an outlet structure. The full-spectrum EDB will have a rip rap emergency overflow spillway that will drain the 100yr peak flows in the event the outlet structure becomes entirely clogged and another 100yr event passes. The spillway will be constructed of soil rip rap. A minimum of 1.0' of freeboard will be provided. The spillway will be situated such that any overflow will be directed north into a vacant parcel, ultimately outfalling into the wetlands depression area. Refer to the design calculations in Appendix B for additional pond design information.

Design Point 47 is where pond 5 will discharge after being routed through a proposed retaining wall. At this outfall location, an energy dissipation feature is required. During the FDR phase, this structure will be identified as being either a riprap apron or a USBR Type IV structure.

Design Point 48 flows are generated from Design Point 2 flows and basin O5 (which is the same as existing conditions basin E3). Flows reaching this location (Misty Acres Filing No. 1 pond facility) are less than what was determined in the filing no. 1 report. The report planned on an inflow value of $Q_{10}=138\text{cfs}$ and a Q_{100} value of 301cfs with flow attenuation of $Q_{10}=58\text{cfs}$ and $Q_{100}=130\text{cfs}$. This report has calculated inflow values of $Q_{10}=107\text{cfs}$ and $Q_{100}=226\text{cfs}$ which yields outflows of $Q_{10}=49\text{cfs}$ and $Q_{100}=96\text{cfs}$. The reason for the difference is that areas planned to route runoff to the pond in filing no. 1 report are now being routed to the projects' pond 1. The existing pond was not designed to provide water quality and as such cannot be used for the projects water quality requirement. Therefore, these flow will be routed around the development along the east side of basins D and E therefore bypassing the proposed project site. The existing 48" RCP outfall pipe is undersized to capture and convey flows northerly under the proposed roadway and therefore must be upsized to a 54" RCP. The overflow path for this pond will be the roadway in which flows will be routed away from homes.

Design Point 49 flows are generated by basin O6. Basin O6 consists of an area that will be routed to a proposed grated inlet which sits above the proposed existing ponds' outfall extension pipe. This pipe is needed to route flow around the project and into the wetlands depression area as it is now being routed to. Due to the amount of flow planned to be released (Q100max=96cfs per the Misty Acres report) the pipe system needs to be sized accordingly to the grades which the pipe will flow at. Due to the route the system will take, the anticipated pipe slopes will be approximately 1%. The computed pipe size from Design Point 49 to Design Point 52 is 54".

Unresolved: What is the overflow path for this DP? Would the roadway act as a drainageway?

Design Point 50 flows are generated from basin O7a (same as existing conditions basin E4). Refer to basin E4 for routing information.

Design Point 51 flows are generated from design point 50 and basin O7b (same as existing conditions basin E5). Refer to basin E5 for routing information. Flows reaching this location is conveyed by a channel through the neighboring subdivision. In order to route this flow around the project it must be collected and tied into the proposed bypass system mentioned in the Design Point 48 narrative. To do this, a concrete collection structure is needed at Design Point 52.

Design Point 52 is located where the proposed 66" RCP pipe coming from the existing Misty Acres Filing No. 1 Pond will enter the structure from the south. Flow will be captured in a collection structure and combine with that from Design Point 51. On the north side of the structure, a proposed pipe will route flows to the wetlands area. Due to the amount of flow anticipated from basins O7a and O7b (Q100~248cfs) combined with that expected from the Misty Acres pond (Q100~111cfs) for a total flow of ~322cfs, a 78" pipe is needed. The 78" pipe will route flows into the existing wetlands depression area thereby bypassing all offsite flows around the project. A detailed design for the collection structure will be provided when the Final Drainage Report is prepared. Due to the amount of flow and the likelihood for scour at the outfall location, an energy dissipation structure will be required. This may be in the form of a riprap apron or some type of concrete energy dissipation structure. A detailed design will be provided when the Final Drainage Report is prepared.

Design Point 53 flows are generated from basin O8 which has is the same basin as E6. See existing conditions narrative Design Point 10.

Design Point 54 flows are generated from the projects' five ponds as well as the existing Misty Acres Filing No. 1 Pond and offsite basins O7a, O7b, O8 and O9. Flows reaching this location are approximately on the order of ~436cfs during the 100yr event. The existing conditions flows have been calculated to be ~488cfs during the 100yr event. Therefore, this project releases ~52cfs less during the 100yr event. Also it is noteworthy to mention that off-site basins O7a and O7b have ponds located within their development areas. These have not been considered in this report but it is likely upon final design and analysis they will result in peak flows less than what has been assumed herein.

Design Point 55 is the outfall from the existing 48" CMP and the addition of 2-48" RCP's. The major and minor storm events will be adequately captured and conveyed beneath County Line Road with this addition of two culverts. At the outfall location there will need to be energy dissipation relief provided. A riprap apron may be used or other such treatment as determined in the final FDR design phase. During the final design process, easements will be necessary for temporary construction easements and permanent maintenance easements. Since the proposed peak runoff has been determined to be less than the existing flow values and the road will no longer overtop, the proposed condition should minimize maintenance and safety risks along with infrastructure loss (i.e. – roadway features).

Design Point 56 flows are generated from basin O10. Basin O10 is the same basin as E8 which consists of undeveloped land and large lot single family development as well as a portion of Interstate 25. Runoff from this basin travels overland easterly to an existing 48" CMP which outfalls on the east side of Interstate 25 into basin O11 (same basin as E9) at Design Point 57.

Design Point 57 consists of an outfall from basins O10 and O11. The proposed site is lower than the proposed outfall and therefore a broad grass lined swale will be constructed to route flows towards Design Point 58.

Design Points 58 and 59. Refer to existing conditions Design Points 8 and 9 for the same routing description. The flow values have changed slightly due to existing conditions basin O10 being minimized by development of this project, but the routing is the same. Regrading the swale to the west may be necessary which will be determined during the construction document preparation phase.

A summary of the basin runoff coefficients, peak flow rates and hydrologic analysis support calculations are provided in Appendix B.

D. Water Quality – 4 Step Process

Four-Step Process

El Paso County requires the MHFD Four Step Process for receiving water protection that focuses on reducing runoff volumes, treating the water quality capture volume (WQCV), stabilizing drainageways, and implementing long-term source controls.

Step 1: Runoff Reduction Practices

This development address Low Impact Development strategies primarily through the utilization of landscape buffers, located in areas adjacent to the building and parking lot areas of the site. Runoff is routed over these grass areas via unconcentrated sheet flow prior to being conveyed to water quality and detention facilities. These areas will be taken into consideration during the FDR final design phase for water quality capture volume reduction. An exhibit and support calculations will be provided at that time.

Step 2: Implement BMPs - Water Quality Capture Volume with Slow Release

On-site flow is directed to five private full-spectrum extended detention basins. These facilities provide Water Quality Capture Volume (WQCV) required for the site by releasing flows over a longer period of time. The proposed facilities meet or exceed the DCM standards for the release rates of full-spectrum detention ponds for water quality capture volumes.

Step 3: Stabilize Drainageways

All the flows generated from impervious portions of this site will be routed to private water quality and detention facilities. These flows will combine with flows from other areas adjacent to the site and discharge into a wetlands depression area at the north end of the project. Only minor channel improvements in basin O12 are being proposed with this development.

Step 4 – Implement Site Specific and Other Source Control BMPs

To adhere to the County's Municipal Separate Storm Sewer System (MS4) requirements, temporary construction BMP's and permanent post construction BMP's will be implemented to reduce the potential of pollutants entering the creek. The implementation of these BMP's will be provided in the Grading, Erosion and Stormwater Quality Control Plan and Stormwater Management Plan for the site. The Stormwater Management Plan also addresses structural and procedural source control BMP's such as materials storage and spill prevention, containment, and control, etc. during construction to protect downstream receiving waters. Refer to the Stormwater Management Plan for this site for additional source control BMP information specific to this site. If deemed necessary, site specific source controls including covering storage/handling areas and spill containment will be used.

E. Water Quality Improvements

The proposed full-spectrum extended detention basins have been analyzed in this study based on the proposed site conditions as shown on the Developed Conditions Drainage Maps.

Full Spectrum Extended Detention Basins

For the purpose of this report, detailed pond designs were not conducted. This will be provided in future FDR's. As such, the MHFD UD-Detention spreadsheet was used for preliminary sizing. Private full spectrum extended detention basins (EDB) are proposed at various locations in the site. The EDB's will have forebays, maintenance access roads, concrete trickle channels, micro pools and outlet structures.

The full-spectrum EDB's will have soil rip rap emergency overflow spillways that will drain the 100yr peak flows in the event the outlet structure becomes entirely clogged and another 100yr event passes. The spillways will be constructed of soil rip rap. A minimum of 1.0' of freeboard will be provided. The spillway will be situated such that any overflow will be directed away from homes. Refer to the design calculations in Appendix B for additional information.

IV. HYDRAULIC ANALYSIS

Methodology

The following MHFD hydraulic software were used in this report:

- MHFD UD - Culvert v4.00 – pipe calculations
- FHWA HY8 and the Civil 3D hydraulics module – culvert calculations

All pipe calculations use “Mannings” equation for open channel flow with a normal depth flow percentage of around 65%. This should account for energy losses found when a final design is provided, and the hydraulic grade line calculations are performed. Final design analysis will be conducted during the Final Drainage Report preparation phase.

V. ENVIRONMENTAL EVALUATIONS

A. Wetland and Riparian Areas

A wetland identification process has not been performed however a boundary delineation has been. Future Final Drainage Reports (FDR's) will include this information.

B. Stormwater Quality

Refer to section III E for water quality provided for this project.

C. Permitting Requirements

A USACE 404 permit is not anticipated for this project since there will be no wetlands disturbance.

VI. ALTERNATIVES EVALUATION

An alternatives evaluation was not conducted for this project since there is no drainage basin planning study for the Bald Mountain watershed.

VII. SELECTED PLAN (IMPLEMENTATION OF THE MASTER PLAN)

A. Plan Hydrology

There is no Master Drainage Plan that encompasses this site or more particularly described as being for the Bald Mountain watershed. A DBPS may be needed in the future as more development in the overall basin is experienced.

Per the Preliminary Drainage Report level of MHFD modeling of the proposed full-spectrum detention/water quality ponds, detention from this project will either be equal to or reduce the major storm (100yr event) discharge from the site from the pre-development. As the proposed development is not projected to increase runoff from the site, there should not be any additional impact to downstream infrastructure besides the extended duration of flows and volume of flows. Off-site improvements at the outfall location of the site (County Line Road – Design Point 55) will be necessary to adequately dissipate energy and will remedy the problem with flows overtopping as they theoretically do at the present time. Refer to Design Point 55 narrative for additional information.

B. System Improvements

Proposed improvements to the existing stormwater infrastructure are not planned at this time since no deficiencies have been found. The existing Misty Acres Filing No. 1 pond is now to be considered oversized compared to what was planned due to routing of project flows to proposed ponds located on site.

C. System Priorities/Phasing

No definitive phasing of the development is known at this time. Once development of any portion of the site begins, the owner will be responsible for providing full-spectrum detention and water quality in accordance with this MDDP. Developed runoff cannot be released from the site until full-spectrum water quality and detention has been provided. Subsequent Final Drainage Reports (FDR's) will establish the timing of such improvements.

D. Deficiency Costs

There is one deficient drainage structure associated with the outfall of the project, the existing 48" CMP pipe under County Line Road. However, this structure will remain and be supplemented with two additional 48" RCP culvert pipes. The existing Misty Acres pond has a short segment of pipe downstream of an existing grated inlet/outlet structure which will be removed and replaced with a 54" pipe. Given this information, there are no deficiency costs for this project.

E. Reimbursable Costs

Due to the watershed being in an unstudied drainage basin and no public infrastructure is being proposed, no improvements will be reimbursable.

F. Governing Agencies Requirements

A United States Army Corps of Engineers (USACE) 404 permit will not be required for this project. There are no other external governmental agency requirements for this development, however CDOT will be a referral agency thereby reviewing the plans and reports since the project is adjacent to Interstate 25. Final Drainage Reports for each future phase of development will be presented to El Paso County with the development of the construction documents.

G. Maintenance Requirements

Regular maintenance of stormwater facilities is essential to ensure long term functionality and effectiveness. The proposed pipes, inlets, manholes, along with the full-spectrum detention and water quality facilities should be inspected regularly, and after significant rainstorms, to verify functionality, document erosion, and remove sediment and debris. Refer to the project's Inspection and Maintenance (IM) Plan for additional information.

The following is a list of recommendations regarding drainage around structures:

- Maintain positive drainage away from all structures at all locations.
- Adhere to guidelines outlined in the geotechnical report (if one has been completed); otherwise refer to the latest International Residential Code (IRC) book.
- Avoid grading low points adjacent to any structures.

The on-site full-spectrum ponds and storm sewer outlined in this report shall be owned and maintained by the metropolitan district or homeowners' association (HOA). The proposed storm sewer facilities located within street right-of-way outlined in this report shall be owned and maintained by the El Paso County.

H. Implementation Recommendation

Development of the site requires the implementation of full-spectrum detention and water quality procedures that have been detailed in this report. The developed conditions will produce runoff at or below existing conditions. This ensures no additional impacts will result downstream as a result of development of this site.

I. Grading and Erosion Control Plans

Grading and Erosion Control Plans will be submitted separately.

VIII. FEE DEVELOPMENT

Since the Bald Mountain drainage basin has not been studied in a master plan document and there are no regional public improvements, no fees have been developed.

IX. SUMMARY

The Master Development Drainage Plan for Monument Ridge East was prepared using the City of Colorado Springs Drainage Criteria Manuals, MHFD Urban Storm Drainage Criteria Manuals and the El Paso County DCM Volume 1 updates. Stormwater quality is provided by proposed private full spectrum extended detention basin facilities located on-site. Site runoff, storm drain, and associated appurtenances will not adversely affect the downstream and surrounding developments. This report is in general conformance with and all other previously approved reports which included portions of this site.

X. REFERENCES

1. Drainage Criteria Manual, Volume I (revised January 2021) and Volume II (revised December 2020), City of Colorado Springs
2. Urban Storm Drainage Criteria Manual, Volumes I-III, Mile High Flood District (MHFD).
3. El Paso County Drainage Criteria Manual Volume 1 update, El Paso County Municode web site
4. El Paso County Engineering Criteria Manual, Drainage Criteria Manual Volume 2, Appendix I.
5. Misty Acres Subdivision Filing No. 1, Final Drainage Report, 2002, Kiowa Engineering Corporation
6. Misty Acres Ranch, Master Development Drainage Plan, 2001, Kiowa Engineering Corporation
7. Interstate 25 Express Lanes: Castle Rock to Monument (The Gap), Hydrology and Hydraulics Report, 2020, CH2M
8. Flood Insurance Rate Map Numbers 08041C0065G and 0804C0276G, El Paso County, Colorado, Revised December 7, 2018, Federal Emergency Management Agency (FEMA)
9. Web Soil Survey, Natural Resources Conservation Service (NRCS)

XI. APPENDICES

A. Stakeholder Meeting Summary

To date there have been no stakeholder or public meetings conducted for this site. Once meetings have been conducted, this information will be included in subsequent Final Drainage Reports for the project.

B. Hydrology

The following hydrologic calculations are located in appendix B:

- Percent Impervious
- Composite Runoff Coefficients
- Basin Runoff Summary
- Surface Routing Summary

C. Hydraulics – Pipes, Inlets and Ponds

The following hydraulic calculations are located in appendix B:

- Inlets
- Culverts
- Pipes
- Full-spectrum Extended Detention and Water Quality ponds

Hydraulic Grade Lines (HGL) for the minor (10yr) and major (100yr) storm event will be provided for each storm sewer pipe in subsequent FDR's.

D. Drainage Maps

Existing and developed drainage maps are located in Appendix C.



Appendix A Maps



United States
Department of
Agriculture

NRCS

Natural
Resources
Conservation
Service

A product of the National
Cooperative Soil Survey,
a joint effort of the United
States Department of
Agriculture and other
Federal agencies, State
agencies including the
Agricultural Experiment
Stations, and local
participants

Custom Soil Resource Report for Castle Rock Area, Colorado, and El Paso County Area, Colorado Monument Ridge East

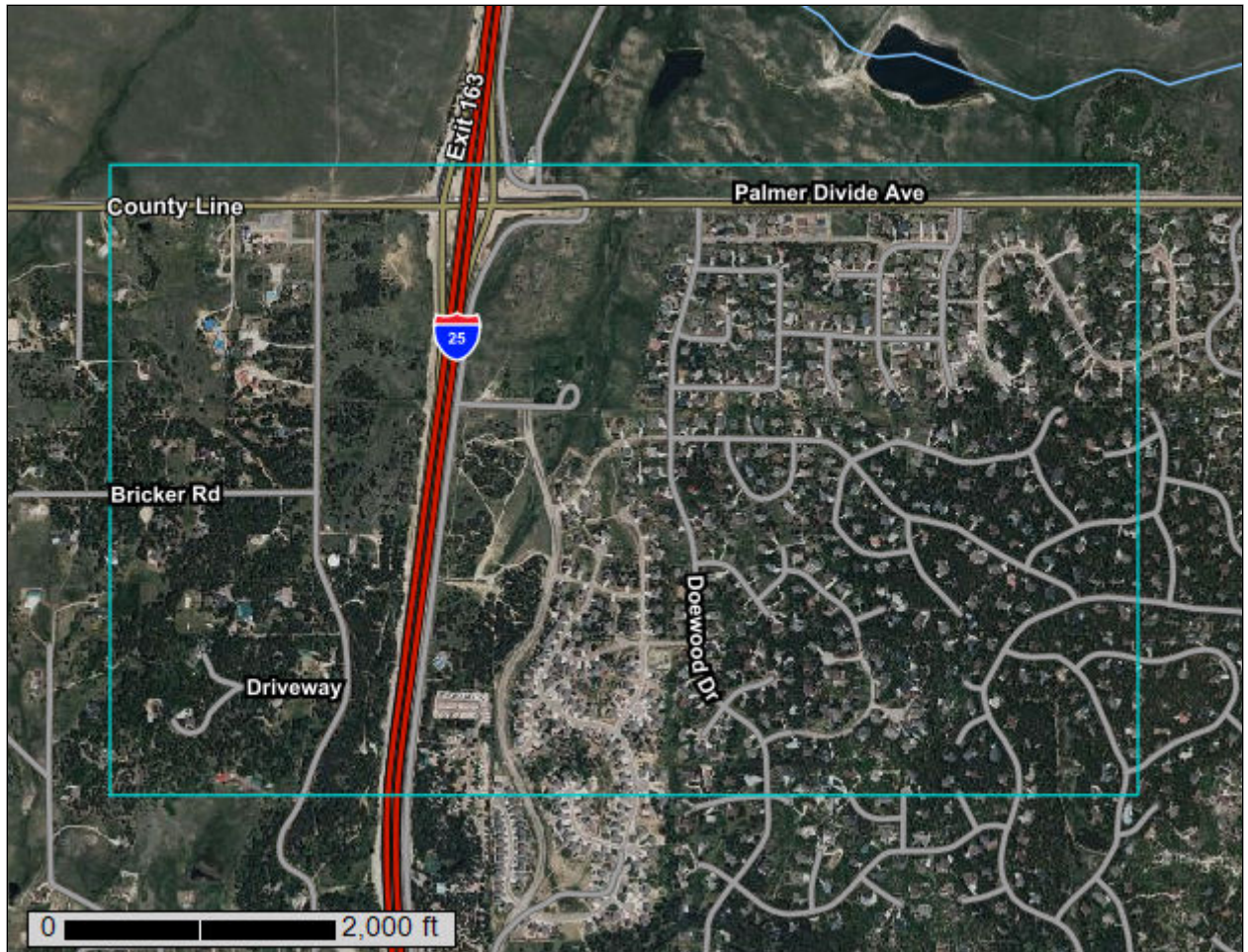

Preface

Soil surveys contain information that affects land use planning in survey areas. They highlight soil limitations that affect various land uses and provide information about the properties of the soils in the survey areas. Soil surveys are designed for many different users, including farmers, ranchers, foresters, agronomists, urban planners, community officials, engineers, developers, builders, and home buyers. Also, conservationists, teachers, students, and specialists in recreation, waste disposal, and pollution control can use the surveys to help them understand, protect, or enhance the environment.

Various land use regulations of Federal, State, and local governments may impose special restrictions on land use or land treatment. Soil surveys identify soil properties that are used in making various land use or land treatment decisions. The information is intended to help the land users identify and reduce the effects of soil limitations on various land uses. The landowner or user is responsible for identifying and complying with existing laws and regulations.

Although soil survey information can be used for general farm, local, and wider area planning, onsite investigation is needed to supplement this information in some cases. Examples include soil quality assessments (<http://www.nrcs.usda.gov/wps/portal/nrcs/main/soils/health/>) and certain conservation and engineering applications. For more detailed information, contact your local USDA Service Center (<https://offices.sc.egov.usda.gov/locator/app?agency=nrcs>) or your NRCS State Soil Scientist (http://www.nrcs.usda.gov/wps/portal/nrcs/detail/soils/contactus/?cid=nrcs142p2_053951).

Great differences in soil properties can occur within short distances. Some soils are seasonally wet or subject to flooding. Some are too unstable to be used as a foundation for buildings or roads. Clayey or wet soils are poorly suited to use as septic tank absorption fields. A high water table makes a soil poorly suited to basements or underground installations.

The National Cooperative Soil Survey is a joint effort of the United States Department of Agriculture and other Federal agencies, State agencies including the Agricultural Experiment Stations, and local agencies. The Natural Resources Conservation Service (NRCS) has leadership for the Federal part of the National Cooperative Soil Survey.

Information about soils is updated periodically. Updated information is available through the NRCS Web Soil Survey, the site for official soil survey information.

The U.S. Department of Agriculture (USDA) prohibits discrimination in all its programs and activities on the basis of race, color, national origin, age, disability, and where applicable, sex, marital status, familial status, parental status, religion, sexual orientation, genetic information, political beliefs, reprisal, or because all or a part of an individual's income is derived from any public assistance program. (Not all prohibited bases apply to all programs.) Persons with disabilities who require

alternative means for communication of program information (Braille, large print, audiotape, etc.) should contact USDA's TARGET Center at (202) 720-2600 (voice and TDD). To file a complaint of discrimination, write to USDA, Director, Office of Civil Rights, 1400 Independence Avenue, S.W., Washington, D.C. 20250-9410 or call (800) 795-3272 (voice) or (202) 720-6382 (TDD). USDA is an equal opportunity provider and employer.

Contents

Preface	2
Soil Map	5
Soil Map.....	6
Legend.....	7
Map Unit Legend.....	9
Map Unit Descriptions.....	9
Castle Rock Area, Colorado.....	12
KfF—Kettle-Falcon complex, 9 to 65 percent slopes.....	12
Lw—Loamy wet alluvial land.....	14
PpE—Peyton-Pring-Crowfoot sandy loams, 5 to 25 percent slopes.....	15
PrE2—Peyton-Pring-Crowfoot complex, 3 to 15 percent slopes, eroded...	17
El Paso County Area, Colorado.....	21
1—Alamosa loam, 1 to 3 percent slopes.....	21
41—Kettle gravelly loamy sand, 8 to 40 percent slopes.....	22
42—Kettle-Rock outcrop complex.....	23
69—Peyton-Pring complex, 8 to 15 percent slopes.....	24
92—Tomah-Crowfoot loamy sands, 3 to 8 percent slopes.....	26

Soil Map

The soil map section includes the soil map for the defined area of interest, a list of soil map units on the map and extent of each map unit, and cartographic symbols displayed on the map. Also presented are various metadata about data used to produce the map, and a description of each soil map unit.

Custom Soil Resource Report Soil Map

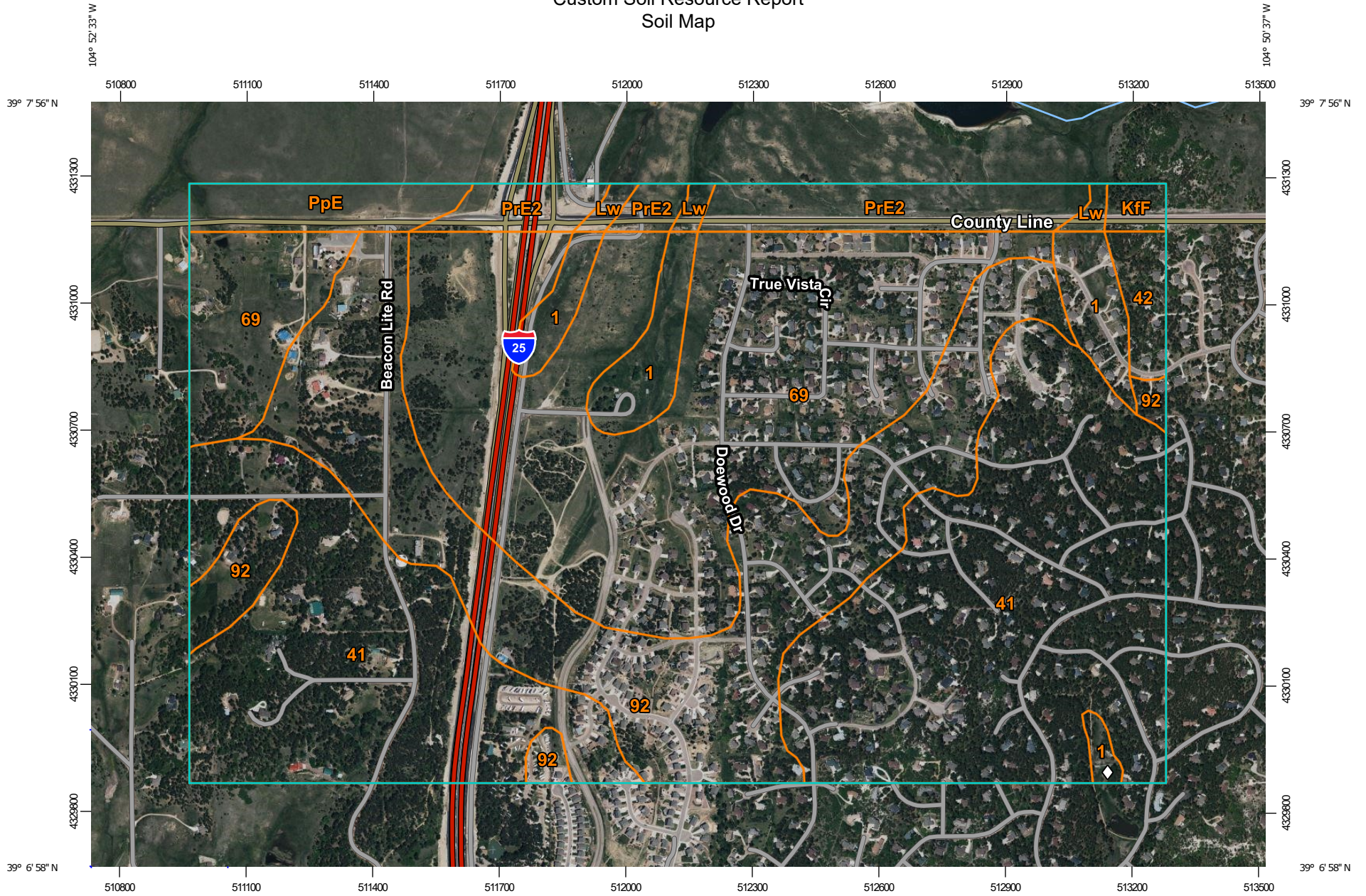

Map Scale: 1:12,700 if printed on A landscape (11" x 8.5") sheet.

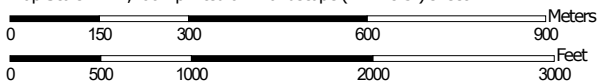

Map projection: Web Mercator Corner coordinates: WGS84 Edge tics: UTM Zone 13N WGS84

MAP LEGEND

Area of Interest (AOI)

 Area of Interest (AOI)

Soils

 Soil Map Unit Polygons

 Soil Map Unit Lines

 Soil Map Unit Points

Special Point Features





-  Blowout
-  Borrow Pit
-  Clay Spot
-  Closed Depression
-  Gravel Pit
-  Gravelly Spot
-  Landfill
-  Lava Flow
-  Marsh or swamp
-  Mine or Quarry
-  Miscellaneous Water
-  Perennial Water
-  Rock Outcrop
-  Saline Spot
-  Sandy Spot
-  Severely Eroded Spot
-  Sinkhole
-  Slide or Slip
-  Sodic Spot

-  Spoil Area
-  Stony Spot
-  Very Stony Spot
-  Wet Spot
-  Other
-  Special Line Features

Water Features

 Streams and Canals

Transportation

-  Rails
-  Interstate Highways
-  US Routes
-  Major Roads
-  Local Roads

Background

 Aerial Photography

MAP INFORMATION

The soil surveys that comprise your AOI were mapped at scales ranging from 1:20,000 to 1:24,000.

Please rely on the bar scale on each map sheet for map measurements.

Source of Map: Natural Resources Conservation Service
 Web Soil Survey URL:
 Coordinate System: Web Mercator (EPSG:3857)

Maps from the Web Soil Survey are based on the Web Mercator projection, which preserves direction and shape but distorts distance and area. A projection that preserves area, such as the Albers equal-area conic projection, should be used if more accurate calculations of distance or area are required.

This product is generated from the USDA-NRCS certified data as of the version date(s) listed below.

Soil Survey Area: Castle Rock Area, Colorado
 Survey Area Data: Version 15, Sep 1, 2022

Soil Survey Area: El Paso County Area, Colorado
 Survey Area Data: Version 20, Sep 2, 2022

Your area of interest (AOI) includes more than one soil survey area. These survey areas may have been mapped at different scales, with a different land use in mind, at different times, or at different levels of detail. This may result in map unit symbols, soil properties, and interpretations that do not completely agree across soil survey area boundaries.

Soil map units are labeled (as space allows) for map scales 1:50,000 or larger.

Date(s) aerial images were photographed: Jun 9, 2021—Jun 12, 2021

The orthophoto or other base map on which the soil lines were compiled and digitized probably differs from the background

MAP LEGEND

MAP INFORMATION

imagery displayed on these maps. As a result, some minor shifting of map unit boundaries may be evident.

Map Unit Legend

Map Unit Symbol	Map Unit Name	Acres in AOI	Percent of AOI
KfF	Kettle-Falcon complex, 9 to 65 percent slopes	4.0	0.5%
Lw	Loamy wet alluvial land	5.3	0.6%
PpE	Peyton-Pring-Crowfoot sandy loams, 5 to 25 percent slopes	17.5	2.1%
PrE2	Peyton-Pring-Crowfoot complex, 3 to 15 percent slopes, eroded	38.5	4.7%
Subtotals for Soil Survey Area		65.2	8.0%
Totals for Area of Interest		813.1	100.0%

Map Unit Symbol	Map Unit Name	Acres in AOI	Percent of AOI
1	Alamosa loam, 1 to 3 percent slopes	35.2	4.3%
41	Kettle gravelly loamy sand, 8 to 40 percent slopes	285.9	35.2%
42	Kettle-Rock outcrop complex	9.1	1.1%
69	Peyton-Pring complex, 8 to 15 percent slopes	245.8	30.2%
92	Tomah-Crowfoot loamy sands, 3 to 8 percent slopes	171.9	21.1%
Subtotals for Soil Survey Area		747.9	92.0%
Totals for Area of Interest		813.1	100.0%

Map Unit Descriptions

The map units delineated on the detailed soil maps in a soil survey represent the soils or miscellaneous areas in the survey area. The map unit descriptions, along with the maps, can be used to determine the composition and properties of a unit.

A map unit delineation on a soil map represents an area dominated by one or more major kinds of soil or miscellaneous areas. A map unit is identified and named according to the taxonomic classification of the dominant soils. Within a taxonomic class there are precisely defined limits for the properties of the soils. On the landscape, however, the soils are natural phenomena, and they have the characteristic variability of all natural phenomena. Thus, the range of some observed properties may extend beyond the limits defined for a taxonomic class. Areas of soils of a single taxonomic class rarely, if ever, can be mapped without including areas of other taxonomic classes. Consequently, every map unit is made up of the soils or miscellaneous areas for which it is named and some minor components that belong to taxonomic classes other than those of the major soils.

Custom Soil Resource Report

Most minor soils have properties similar to those of the dominant soil or soils in the map unit, and thus they do not affect use and management. These are called noncontrasting, or similar, components. They may or may not be mentioned in a particular map unit description. Other minor components, however, have properties and behavioral characteristics divergent enough to affect use or to require different management. These are called contrasting, or dissimilar, components. They generally are in small areas and could not be mapped separately because of the scale used. Some small areas of strongly contrasting soils or miscellaneous areas are identified by a special symbol on the maps. If included in the database for a given area, the contrasting minor components are identified in the map unit descriptions along with some characteristics of each. A few areas of minor components may not have been observed, and consequently they are not mentioned in the descriptions, especially where the pattern was so complex that it was impractical to make enough observations to identify all the soils and miscellaneous areas on the landscape.

The presence of minor components in a map unit in no way diminishes the usefulness or accuracy of the data. The objective of mapping is not to delineate pure taxonomic classes but rather to separate the landscape into landforms or landform segments that have similar use and management requirements. The delineation of such segments on the map provides sufficient information for the development of resource plans. If intensive use of small areas is planned, however, onsite investigation is needed to define and locate the soils and miscellaneous areas.

An identifying symbol precedes the map unit name in the map unit descriptions. Each description includes general facts about the unit and gives important soil properties and qualities.

Soils that have profiles that are almost alike make up a *soil series*. Except for differences in texture of the surface layer, all the soils of a series have major horizons that are similar in composition, thickness, and arrangement.

Soils of one series can differ in texture of the surface layer, slope, stoniness, salinity, degree of erosion, and other characteristics that affect their use. On the basis of such differences, a soil series is divided into *soil phases*. Most of the areas shown on the detailed soil maps are phases of soil series. The name of a soil phase commonly indicates a feature that affects use or management. For example, Alpha silt loam, 0 to 2 percent slopes, is a phase of the Alpha series.

Some map units are made up of two or more major soils or miscellaneous areas. These map units are complexes, associations, or undifferentiated groups.

A *complex* consists of two or more soils or miscellaneous areas in such an intricate pattern or in such small areas that they cannot be shown separately on the maps. The pattern and proportion of the soils or miscellaneous areas are somewhat similar in all areas. Alpha-Beta complex, 0 to 6 percent slopes, is an example.

An *association* is made up of two or more geographically associated soils or miscellaneous areas that are shown as one unit on the maps. Because of present or anticipated uses of the map units in the survey area, it was not considered practical or necessary to map the soils or miscellaneous areas separately. The pattern and relative proportion of the soils or miscellaneous areas are somewhat similar. Alpha-Beta association, 0 to 2 percent slopes, is an example.

An *undifferentiated group* is made up of two or more soils or miscellaneous areas that could be mapped individually but are mapped as one unit because similar interpretations can be made for use and management. The pattern and proportion

Custom Soil Resource Report

of the soils or miscellaneous areas in a mapped area are not uniform. An area can be made up of only one of the major soils or miscellaneous areas, or it can be made up of all of them. Alpha and Beta soils, 0 to 2 percent slopes, is an example.

Some surveys include *miscellaneous areas*. Such areas have little or no soil material and support little or no vegetation. Rock outcrop is an example.

Castle Rock Area, Colorado

KfF—Kettle-Falcon complex, 9 to 65 percent slopes

Map Unit Setting

National map unit symbol: jqz2
Elevation: 6,600 to 8,000 feet
Mean annual precipitation: 17 to 21 inches
Mean annual air temperature: 45 to 47 degrees F
Frost-free period: 115 to 125 days
Farmland classification: Not prime farmland

Map Unit Composition

Kettle and similar soils: 50 percent
Falcon and similar soils: 35 percent
Minor components: 15 percent
Estimates are based on observations, descriptions, and transects of the mapunit.

Description of Kettle

Setting

Landform: Hills, ridges
Landform position (three-dimensional): Side slope, base slope, crest
Down-slope shape: Linear
Across-slope shape: Linear
Parent material: Locally transported sandy alluvium derived from arkose

Typical profile

Oi - 0 to 1 inches: slightly decomposed plant material
H1 - 1 to 10 inches: loamy sand
H2 - 10 to 18 inches: sand
H3 - 18 to 60 inches: gravelly loamy coarse sand

Properties and qualities

Slope: 9 to 25 percent
Depth to restrictive feature: More than 80 inches
Drainage class: Somewhat excessively drained
Runoff class: Low
Capacity of the most limiting layer to transmit water (Ksat): High to very high (2.00 to 20.00 in/hr)
Depth to water table: More than 80 inches
Frequency of flooding: None
Frequency of ponding: None
Maximum salinity: Nonsaline to very slightly saline (0.0 to 2.0 mmhos/cm)
Available water supply, 0 to 60 inches: Low (about 4.7 inches)

Interpretive groups

Land capability classification (irrigated): None specified
Land capability classification (nonirrigated): 6e
Hydrologic Soil Group: A
Ecological site: F048AY925CO - Ponderosa Pine Forest
Hydric soil rating: No

Description of Falcon

Setting

Landform: Cliffs

Down-slope shape: Linear

Across-slope shape: Linear

Parent material: Alluvium derived from arkosic sandstone and/or conglomerate

Typical profile

O_i - 0 to 1 inches: slightly decomposed plant material

H₁ - 1 to 8 inches: sandy loam

H₂ - 8 to 15 inches: gravelly sandy loam

H₃ - 15 to 18 inches: unweathered bedrock

Properties and qualities

Slope: 25 to 65 percent

Depth to restrictive feature: 4 to 20 inches to lithic bedrock

Drainage class: Well drained

Runoff class: Very high

Capacity of the most limiting layer to transmit water (K_{sat}): Moderately low to moderately high (0.06 to 0.20 in/hr)

Depth to water table: More than 80 inches

Frequency of flooding: None

Frequency of ponding: None

Maximum salinity: Nonsaline to very slightly saline (0.0 to 2.0 mmhos/cm)

Available water supply, 0 to 60 inches: Very low (about 1.7 inches)

Interpretive groups

Land capability classification (irrigated): None specified

Land capability classification (nonirrigated): 7e

Hydrologic Soil Group: D

Ecological site: F048AY925CO - Ponderosa Pine Forest

Hydric soil rating: No

Minor Components

Rock outcrop

Percent of map unit: 7 percent

Hydric soil rating: No

Pring

Percent of map unit: 7 percent

Hydric soil rating: No

Aquic haploborolls

Percent of map unit: 1 percent

Landform: Swales

Hydric soil rating: Yes

Lw—Loamy wet alluvial land

Map Unit Setting

National map unit symbol: jqzd
Elevation: 7,000 to 8,000 feet
Mean annual precipitation: 17 to 19 inches
Mean annual air temperature: 44 to 46 degrees F
Frost-free period: 115 to 120 days
Farmland classification: Not prime farmland

Map Unit Composition

Loamy wet alluvial land: 85 percent
Minor components: 15 percent
Estimates are based on observations, descriptions, and transects of the mapunit.

Description of Loamy Wet Alluvial Land

Setting

Landform: Drainageways, swales, flood plains
Down-slope shape: Linear
Across-slope shape: Linear

Typical profile

H1 - 0 to 20 inches: sandy loam
H2 - 20 to 60 inches: stratified sand to clay

Properties and qualities

Slope: 1 to 5 percent
Drainage class: Poorly drained
Runoff class: High
Capacity of the most limiting layer to transmit water (Ksat): Moderately low to high
(0.06 to 6.00 in/hr)
Depth to water table: About 0 to 24 inches
Frequency of flooding: FrequentNone
Calcium carbonate, maximum content: 5 percent
Gypsum, maximum content: 2 percent
Maximum salinity: Very slightly saline to moderately saline (2.0 to 8.0 mmhos/cm)
Sodium adsorption ratio, maximum: 2.0
Available water supply, 0 to 60 inches: Moderate (about 6.8 inches)

Interpretive groups

Land capability classification (irrigated): None specified
Land capability classification (nonirrigated): 5w
Hydrologic Soil Group: D
Hydric soil rating: No

Minor Components

Sandy wet alluvial land

Percent of map unit: 14 percent
Hydric soil rating: No

Fluvaquentic haplaquolls

Percent of map unit: 1 percent
Landform: Sloughs
Hydric soil rating: Yes

PpE—Peyton-Pring-Crowfoot sandy loams, 5 to 25 percent slopes

Map Unit Setting

National map unit symbol: jqzn
Elevation: 6,500 to 8,000 feet
Mean annual precipitation: 15 to 18 inches
Mean annual air temperature: 44 to 46 degrees F
Frost-free period: 115 to 120 days
Farmland classification: Not prime farmland

Map Unit Composition

Peyton and similar soils: 40 percent
Pring and similar soils: 25 percent
Crowfoot and similar soils: 25 percent
Minor components: 10 percent
Estimates are based on observations, descriptions, and transects of the mapunit.

Description of Peyton

Setting

Landform: Valley sides, ridges
Down-slope shape: Linear
Across-slope shape: Linear
Parent material: Weathered alluvium derived from arkose

Typical profile

H1 - 0 to 11 inches: sandy loam
H2 - 11 to 30 inches: sandy clay loam
H3 - 30 to 40 inches: sandy loam
H4 - 40 to 60 inches: sandy loam

Properties and qualities

Slope: 5 to 15 percent
Depth to restrictive feature: More than 80 inches
Drainage class: Well drained
Runoff class: Medium
Capacity of the most limiting layer to transmit water (Ksat): Moderately high (0.20 to 0.60 in/hr)
Depth to water table: More than 80 inches

Custom Soil Resource Report

Frequency of flooding: None
Frequency of ponding: None
Available water supply, 0 to 60 inches: Moderate (about 7.5 inches)

Interpretive groups

Land capability classification (irrigated): None specified
Land capability classification (nonirrigated): 6e
Hydrologic Soil Group: C
Ecological site: R048AY222CO - Loamy Park
Hydric soil rating: No

Description of Pring

Setting

Landform: Hills
Landform position (three-dimensional): Crest, base slope
Down-slope shape: Linear
Across-slope shape: Linear
Parent material: Alluvium derived from arkosic sedimentary rock

Typical profile

H1 - 0 to 12 inches: sandy loam
H2 - 12 to 60 inches: gravelly sandy loam

Properties and qualities

Slope: 5 to 25 percent
Depth to restrictive feature: More than 80 inches
Drainage class: Well drained
Runoff class: Low
Capacity of the most limiting layer to transmit water (Ksat): Moderately high to high
(0.60 to 6.00 in/hr)
Depth to water table: More than 80 inches
Frequency of flooding: None
Frequency of ponding: None
Available water supply, 0 to 60 inches: Moderate (about 6.1 inches)

Interpretive groups

Land capability classification (irrigated): None specified
Land capability classification (nonirrigated): 6e
Hydrologic Soil Group: A
Ecological site: R048AY222CO - Loamy Park
Hydric soil rating: No

Description of Crowfoot

Setting

Landform: Valley sides, ridges
Down-slope shape: Linear
Across-slope shape: Linear
Parent material: Residuum weathered from arkosic sedimentary rock

Typical profile

H1 - 0 to 6 inches: sandy loam
H2 - 6 to 19 inches: loamy sand
H3 - 19 to 32 inches: gravelly sandy clay loam
H4 - 32 to 43 inches: gravelly sandy loam
H5 - 43 to 60 inches: coarse sand

Custom Soil Resource Report

Properties and qualities

Slope: 5 to 15 percent
Depth to restrictive feature: More than 80 inches
Drainage class: Well drained
Runoff class: Medium
Capacity of the most limiting layer to transmit water (Ksat): Moderately high to high
(0.20 to 2.00 in/hr)
Depth to water table: More than 80 inches
Frequency of flooding: None
Frequency of ponding: None
Available water supply, 0 to 60 inches: Low (about 5.0 inches)

Interpretive groups

Land capability classification (irrigated): None specified
Land capability classification (nonirrigated): 6e
Hydrologic Soil Group: B
Ecological site: R049XY216CO - Sandy Divide
Hydric soil rating: No

Minor Components

Brussett

Percent of map unit: 3 percent
Hydric soil rating: No

Jarre

Percent of map unit: 3 percent
Hydric soil rating: No

Tomah

Percent of map unit: 3 percent
Hydric soil rating: No

Aquic haploborolls

Percent of map unit: 1 percent
Landform: Swales
Hydric soil rating: Yes

PrE2—Peyton-Pring-Crowfoot complex, 3 to 15 percent slopes, eroded

Map Unit Setting

National map unit symbol: jqzp
Elevation: 6,500 to 8,000 feet
Mean annual precipitation: 15 to 18 inches
Mean annual air temperature: 44 to 46 degrees F
Frost-free period: 115 to 120 days
Farmland classification: Not prime farmland

Map Unit Composition

Peyton, eroded, and similar soils: 40 percent
Pring, eroded, and similar soils: 25 percent
Crowfoot, eroded, and similar soils: 20 percent
Minor components: 15 percent
Estimates are based on observations, descriptions, and transects of the mapunit.

Description of Peyton, Eroded

Setting

Landform: Plateaus, mesas
Down-slope shape: Linear
Across-slope shape: Linear
Parent material: Weathered alluvium derived from arkose

Typical profile

H1 - 0 to 11 inches: sandy loam
H2 - 11 to 30 inches: sandy clay loam
H3 - 30 to 40 inches: sandy loam
H4 - 40 to 60 inches: sandy loam

Properties and qualities

Slope: 3 to 15 percent
Depth to restrictive feature: More than 80 inches
Drainage class: Well drained
Runoff class: Medium
Capacity of the most limiting layer to transmit water (Ksat): Moderately high (0.20 to 0.60 in/hr)
Depth to water table: More than 80 inches
Frequency of flooding: None
Frequency of ponding: None
Available water supply, 0 to 60 inches: Moderate (about 7.5 inches)

Interpretive groups

Land capability classification (irrigated): None specified
Land capability classification (nonirrigated): 6e
Hydrologic Soil Group: C
Ecological site: R049XY216CO - Sandy Divide
Hydric soil rating: No

Description of Pring, Eroded

Setting

Landform: Plateaus, mesas
Down-slope shape: Linear
Across-slope shape: Linear
Parent material: Alluvium derived from arkosic sedimentary rock

Typical profile

H1 - 0 to 12 inches: gravelly sandy loam
H2 - 12 to 60 inches: gravelly sandy loam

Properties and qualities

Slope: 3 to 15 percent
Depth to restrictive feature: More than 80 inches
Drainage class: Well drained
Runoff class: Low

Custom Soil Resource Report

Capacity of the most limiting layer to transmit water (Ksat): Moderately high to high
(0.60 to 6.00 in/hr)

Depth to water table: More than 80 inches

Frequency of flooding: None

Frequency of ponding: None

Available water supply, 0 to 60 inches: Low (about 5.9 inches)

Interpretive groups

Land capability classification (irrigated): None specified

Land capability classification (nonirrigated): 6e

Hydrologic Soil Group: A

Ecological site: R048AY222CO - Loamy Park

Hydric soil rating: No

Description of Crowfoot, Eroded

Setting

Landform: Plateaus, mesas

Down-slope shape: Linear

Across-slope shape: Linear

Parent material: Residuum weathered from arkosic sedimentary rock

Typical profile

H1 - 0 to 6 inches: sandy loam

H2 - 6 to 19 inches: loamy sand

H3 - 19 to 32 inches: gravelly sandy clay loam

H4 - 32 to 43 inches: gravelly sandy loam

H5 - 43 to 60 inches: coarse sand

Properties and qualities

Slope: 3 to 15 percent

Depth to restrictive feature: More than 80 inches

Drainage class: Well drained

Runoff class: Medium

Capacity of the most limiting layer to transmit water (Ksat): Moderately high to high
(0.20 to 2.00 in/hr)

Depth to water table: More than 80 inches

Frequency of flooding: None

Frequency of ponding: None

Available water supply, 0 to 60 inches: Low (about 5.0 inches)

Interpretive groups

Land capability classification (irrigated): None specified

Land capability classification (nonirrigated): 6e

Hydrologic Soil Group: B

Ecological site: R049XY216CO - Sandy Divide

Hydric soil rating: No

Minor Components

Kippen

Percent of map unit: 8 percent

Hydric soil rating: No

Truckton

Percent of map unit: 7 percent

Hydric soil rating: No

El Paso County Area, Colorado

1—Alamosa loam, 1 to 3 percent slopes

Map Unit Setting

National map unit symbol: 3670

Elevation: 7,200 to 7,700 feet

Farmland classification: Prime farmland if irrigated and reclaimed of excess salts and sodium

Map Unit Composition

Alamosa and similar soils: 85 percent

Estimates are based on observations, descriptions, and transects of the mapunit.

Description of Alamosa

Setting

Landform: Fans, flood plains

Down-slope shape: Linear

Across-slope shape: Linear

Parent material: Alluvium

Typical profile

A - 0 to 6 inches: loam

Bt - 6 to 14 inches: clay loam

Btk - 14 to 33 inches: clay loam

Cg1 - 33 to 53 inches: sandy clay loam

Cg2 - 53 to 60 inches: sandy loam

Properties and qualities

Slope: 1 to 3 percent

Depth to restrictive feature: More than 80 inches

Drainage class: Poorly drained

Runoff class: Very high

Capacity of the most limiting layer to transmit water (Ksat): Moderately high (0.20 to 0.60 in/hr)

Depth to water table: About 12 to 18 inches

Frequency of flooding: NoneFrequent

Frequency of ponding: None

Calcium carbonate, maximum content: 5 percent

Maximum salinity: Very slightly saline to strongly saline (2.0 to 16.0 mmhos/cm)

Available water supply, 0 to 60 inches: High (about 10.2 inches)

Interpretive groups

Land capability classification (irrigated): None specified

Land capability classification (nonirrigated): 5w

Hydrologic Soil Group: D

Ecological site: R048AY241CO - Mountain Meadow

Hydric soil rating: Yes

Minor Components

Other soils

Percent of map unit:

Hydric soil rating: No

41—Kettle gravelly loamy sand, 8 to 40 percent slopes

Map Unit Setting

National map unit symbol: 368h
Elevation: 7,000 to 7,700 feet
Farmland classification: Not prime farmland

Map Unit Composition

Kettle and similar soils: 85 percent
Estimates are based on observations, descriptions, and transects of the mapunit.

Description of Kettle

Setting

Landform: Hills
Landform position (three-dimensional): Side slope
Down-slope shape: Linear
Across-slope shape: Linear
Parent material: Sandy alluvium derived from arkose

Typical profile

E - 0 to 16 inches: gravelly loamy sand
Bt - 16 to 40 inches: gravelly sandy loam
C - 40 to 60 inches: extremely gravelly loamy sand

Properties and qualities

Slope: 8 to 40 percent
Depth to restrictive feature: More than 80 inches
Drainage class: Somewhat excessively drained
Runoff class: Medium
Capacity of the most limiting layer to transmit water (Ksat): High (2.00 to 6.00 in/hr)
Depth to water table: More than 80 inches
Frequency of flooding: None
Frequency of ponding: None
Available water supply, 0 to 60 inches: Low (about 3.4 inches)

Interpretive groups

Land capability classification (irrigated): None specified
Land capability classification (nonirrigated): 7e
Hydrologic Soil Group: B
Ecological site: F048AY908CO - Mixed Conifer
Hydric soil rating: No

Minor Components

Other soils

Percent of map unit:
Hydric soil rating: No

Pleasant

Percent of map unit:
Landform: Depressions
Hydric soil rating: Yes

42—Kettle-Rock outcrop complex

Map Unit Setting

National map unit symbol: 368j
Elevation: 6,800 to 7,700 feet
Frost-free period: 110 to 130 days
Farmland classification: Not prime farmland

Map Unit Composition

Kettle and similar soils: 60 percent
Rock outcrop: 20 percent
Estimates are based on observations, descriptions, and transects of the mapunit.

Description of Kettle

Setting

Landform: Hills
Landform position (three-dimensional): Side slope
Down-slope shape: Linear
Across-slope shape: Linear
Parent material: Sandy alluvium derived from arkose

Typical profile

E - 0 to 16 inches: gravelly loamy sand
Bt - 16 to 40 inches: gravelly sandy loam
C - 40 to 60 inches: extremely gravelly loamy sand

Properties and qualities

Slope: 8 to 40 percent
Depth to restrictive feature: More than 80 inches
Drainage class: Somewhat excessively drained
Runoff class: Medium
Capacity of the most limiting layer to transmit water (Ksat): High (2.00 to 6.00 in/hr)
Depth to water table: More than 80 inches
Frequency of flooding: None
Frequency of ponding: None
Available water supply, 0 to 60 inches: Low (about 3.4 inches)

Interpretive groups

Land capability classification (irrigated): None specified
Land capability classification (nonirrigated): 7e
Hydrologic Soil Group: B
Ecological site: F048AY908CO - Mixed Conifer
Hydric soil rating: No

Description of Rock Outcrop

Typical profile

R - 0 to 60 inches: unweathered bedrock

Properties and qualities

Slope: 8 to 60 percent

Depth to restrictive feature: 0 inches to lithic bedrock

Available water supply, 0 to 60 inches: Very low (about 0.0 inches)

Interpretive groups

Land capability classification (irrigated): None specified

Land capability classification (nonirrigated): 8s

Hydrologic Soil Group: D

Hydric soil rating: No

Minor Components

Other soils

Percent of map unit:

Hydric soil rating: No

69—Peyton-Pring complex, 8 to 15 percent slopes

Map Unit Setting

National map unit symbol: 369g

Elevation: 6,800 to 7,600 feet

Farmland classification: Not prime farmland

Map Unit Composition

Peyton and similar soils: 40 percent

Pring and similar soils: 30 percent

Estimates are based on observations, descriptions, and transects of the mapunit.

Description of Peyton

Setting

Landform: Hills

Landform position (three-dimensional): Side slope

Down-slope shape: Linear

Across-slope shape: Linear

Parent material: Arkosic alluvium derived from sedimentary rock and/or arkosic residuum weathered from sedimentary rock

Typical profile

A - 0 to 12 inches: sandy loam

Bt - 12 to 25 inches: sandy clay loam

BC - 25 to 35 inches: sandy clay loam

C - 35 to 60 inches: sandy loam

Custom Soil Resource Report

Properties and qualities

Slope: 8 to 9 percent
Depth to restrictive feature: More than 80 inches
Drainage class: Well drained
Runoff class: Medium
Capacity of the most limiting layer to transmit water (Ksat): Moderately high (0.20 to 0.60 in/hr)
Depth to water table: More than 80 inches
Frequency of flooding: None
Frequency of ponding: None
Available water supply, 0 to 60 inches: Moderate (about 7.3 inches)

Interpretive groups

Land capability classification (irrigated): None specified
Land capability classification (nonirrigated): 4e
Hydrologic Soil Group: B
Ecological site: R049XY216CO - Sandy Divide
Hydric soil rating: No

Description of Pring

Setting

Landform: Hills
Landform position (three-dimensional): Side slope
Down-slope shape: Linear
Across-slope shape: Linear
Parent material: Arkosic alluvium derived from sedimentary rock

Typical profile

A - 0 to 14 inches: coarse sandy loam
C - 14 to 60 inches: gravelly sandy loam

Properties and qualities

Slope: 8 to 15 percent
Depth to restrictive feature: More than 80 inches
Drainage class: Well drained
Runoff class: Low
Capacity of the most limiting layer to transmit water (Ksat): High (2.00 to 6.00 in/hr)
Depth to water table: More than 80 inches
Frequency of flooding: None
Frequency of ponding: None
Available water supply, 0 to 60 inches: Low (about 6.0 inches)

Interpretive groups

Land capability classification (irrigated): None specified
Land capability classification (nonirrigated): 6e
Hydrologic Soil Group: B
Ecological site: R048AY222CO - Loamy Park
Hydric soil rating: No

Minor Components

Other soils

Percent of map unit:
Hydric soil rating: No

Pleasant

Percent of map unit:
Landform: Depressions
Hydric soil rating: Yes

92—Tomah-Crowfoot loamy sands, 3 to 8 percent slopes

Map Unit Setting

National map unit symbol: 36b9
Elevation: 7,300 to 7,600 feet
Farmland classification: Not prime farmland

Map Unit Composition

Tomah and similar soils: 50 percent
Crowfoot and similar soils: 30 percent
Estimates are based on observations, descriptions, and transects of the mapunit.

Description of Tomah

Setting

Landform: Alluvial fans, hills
Landform position (three-dimensional): Side slope, crest
Down-slope shape: Linear
Across-slope shape: Linear
Parent material: Alluvium derived from arkose and/or residuum weathered from arkose

Typical profile

A - 0 to 10 inches: loamy sand
E - 10 to 22 inches: coarse sand
Bt - 22 to 48 inches: stratified coarse sand to sandy clay loam
C - 48 to 60 inches: coarse sand

Properties and qualities

Slope: 3 to 8 percent
Depth to restrictive feature: More than 80 inches
Drainage class: Well drained
Runoff class: Medium
Capacity of the most limiting layer to transmit water (Ksat): Moderately high to high
(0.60 to 2.00 in/hr)
Depth to water table: More than 80 inches
Frequency of flooding: None
Frequency of ponding: None
Available water supply, 0 to 60 inches: Low (about 4.6 inches)

Interpretive groups

Land capability classification (irrigated): None specified
Land capability classification (nonirrigated): 4e
Hydrologic Soil Group: B

Custom Soil Resource Report

Ecological site: R049XY216CO - Sandy Divide
Hydric soil rating: No

Description of Crowfoot

Setting

Landform: Hills, alluvial fans
Landform position (three-dimensional): Side slope, crest
Down-slope shape: Linear
Across-slope shape: Linear
Parent material: Alluvium

Typical profile

A - 0 to 12 inches: loamy sand
E - 12 to 23 inches: sand
Bt - 23 to 36 inches: sandy clay loam
C - 36 to 60 inches: coarse sand

Properties and qualities

Slope: 3 to 8 percent
Depth to restrictive feature: More than 80 inches
Drainage class: Well drained
Runoff class: Medium
Capacity of the most limiting layer to transmit water (Ksat): Moderately high to high
(0.60 to 2.00 in/hr)
Depth to water table: More than 80 inches
Frequency of flooding: None
Frequency of ponding: None
Available water supply, 0 to 60 inches: Low (about 4.7 inches)

Interpretive groups

Land capability classification (irrigated): None specified
Land capability classification (nonirrigated): 4e
Hydrologic Soil Group: B
Ecological site: R049XY216CO - Sandy Divide
Hydric soil rating: No

Minor Components

Other soils

Percent of map unit:
Hydric soil rating: No

Pleasant

Percent of map unit:
Landform: Depressions
Hydric soil rating: Yes

National Flood Hazard Layer FIRMMette



104°51'58"W 39°7'50"N



Basemap: USGS National Map: Orthoimagery: Data refreshed October, 2020

104°51'21"W 39°7'23"N

Legend

SEE FIS REPORT FOR DETAILED LEGEND AND INDEX MAP FOR FIRM PANEL LAYOUT

- | | | |
|------------------------------------|--|--|
| SPECIAL FLOOD HAZARD AREAS | | Without Base Flood Elevation (BFE)
<i>Zone A, V, A99</i> |
| | | With BFE or Depth <i>Zone AE, AO, AH, VE, AR</i> |
| | | Regulatory Floodway |
| OTHER AREAS OF FLOOD HAZARD | | 0.2% Annual Chance Flood Hazard, Areas of 1% annual chance flood with average depth less than one foot or with drainage areas of less than one square mile <i>Zone X</i> |
| | | Future Conditions 1% Annual Chance Flood Hazard <i>Zone X</i> |
| | | Area with Reduced Flood Risk due to Levee. See Notes. <i>Zone X</i> |
| | | Area with Flood Risk due to Levee <i>Zone D</i> |
| OTHER AREAS | | NO SCREEN Area of Minimal Flood Hazard <i>Zone X</i> |
| | | Effective LOMRs |
| GENERAL STRUCTURES | | Area of Undetermined Flood Hazard <i>Zone D</i> |
| | | Channel, Culvert, or Storm Sewer |
| | | Levee, Dike, or Floodwall |
| OTHER FEATURES | | 20.2 Cross Sections with 1% Annual Chance |
| | | 17.5 Water Surface Elevation |
| | | Coastal Transect |
| | | Base Flood Elevation Line (BFE) |
| | | Limit of Study |
| | | Jurisdiction Boundary |
| | | Coastal Transect Baseline |
| | | Profile Baseline |
| | | Hydrographic Feature |
| MAP PANELS | | Digital Data Available |
| | | No Digital Data Available |
| | | Unmapped |
| | | The pin displayed on the map is an approximate point selected by the user and does not represent an authoritative property location. |



This map complies with FEMA's standards for the use of digital flood maps if it is not void as described below. The basemap shown complies with FEMA's basemap accuracy standards

The flood hazard information is derived directly from the authoritative NFHL web services provided by FEMA. This map was exported on **1/18/2023 at 3:52 AM** and does not reflect changes or amendments subsequent to this date and time. The NFHL and effective information may change or become superseded by new data over time.

This map image is void if the one or more of the following map elements do not appear: basemap imagery, flood zone labels, legend, scale bar, map creation date, community identifiers, FIRM panel number, and FIRM effective date. Map images for unmapped and unmodernized areas cannot be used for regulatory purposes.

National Flood Hazard Layer FIRMette



104°51'59"W 39°7'38"N

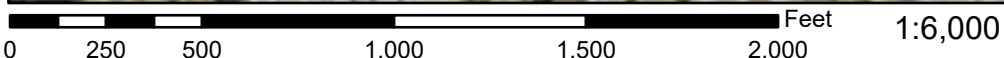

Basemap: USGS National Map: Orthoimagery: Data refreshed October, 2020

Legend

SEE FIS REPORT FOR DETAILED LEGEND AND INDEX MAP FOR FIRM PANEL LAYOUT

SPECIAL FLOOD HAZARD AREAS		Without Base Flood Elevation (BFE) <i>Zone A, V, A99</i>
		With BFE or Depth <i>Zone AE, AO, AH, VE, AR</i>
		Regulatory Floodway
OTHER AREAS OF FLOOD HAZARD		0.2% Annual Chance Flood Hazard, Areas of 1% annual chance flood with average depth less than one foot or with drainage areas of less than one square mile <i>Zone X</i>
		Future Conditions 1% Annual Chance Flood Hazard <i>Zone X</i>
		Area with Reduced Flood Risk due to Levee. See Notes. <i>Zone X</i>
		Area with Flood Risk due to Levee <i>Zone D</i>
OTHER AREAS		NO SCREEN Area of Minimal Flood Hazard <i>Zone X</i>
		Effective LOMRs
GENERAL STRUCTURES		Area of Undetermined Flood Hazard <i>Zone D</i>
		Channel, Culvert, or Storm Sewer
		Levee, Dike, or Floodwall
OTHER FEATURES		20.2 Cross Sections with 1% Annual Chance
		17.5 Water Surface Elevation
		Coastal Transect
		Base Flood Elevation Line (BFE)
		Limit of Study
MAP PANELS		Digital Data Available
		No Digital Data Available
		Unmapped
		The pin displayed on the map is an approximate point selected by the user and does not represent an authoritative property location.



This map complies with FEMA's standards for the use of digital flood maps if it is not void as described below. The basemap shown complies with FEMA's basemap accuracy standards

The flood hazard information is derived directly from the authoritative NFHL web services provided by FEMA. This map was exported on **1/18/2023 at 3:50 AM** and does not reflect changes or amendments subsequent to this date and time. The NFHL and effective information may change or become superseded by new data over time.

This map image is void if the one or more of the following map elements do not appear: basemap imagery, flood zone labels, legend, scale bar, map creation date, community identifiers, FIRM panel number, and FIRM effective date. Map images for unmapped and unmodernized areas cannot be used for regulatory purposes.



Appendix B Calculations

MONUMENT RIDGE EAST
MASTER DEVELOPMENT DRAINAGE PLAN and PRELIMINARY DRAINAGE REPORT
(Percent Impervious Summary)

Basin	Area (acres)									% Imp
	Streets/Drives/Walks	Streets - Gravel	Roof	Lawn	Res 1/8	Res 1/4	Res 1/3	Res 1/2	TOTAL	
E1		1.86		30.03					31.89	4.67
E2		0.84						0.52	1.36	58.97
E3	10.77					2.45	4.47	42.47	60.16	39.41
E4	3.81						12.98	48.78	65.57	30.35
E5	2.18							15.29	17.47	34.36
E6	0.55						0.83		1.38	57.90
E7	0.81			34.79				5.88	41.48	5.50
E8	1.59	2.74	0.99	55.15					60.47	7.73
E9	1.72			1.2					2.92	58.90
E10	1.42	0.4		11.34					13.16	13.22
E11	1.91			3.34					5.25	36.38
A1	2.14		1.55	1.06					4.75	74.42
A2	0.78		0.88	0.75					2.41	65.23
A3	0.04		0.09	1.28					1.41	8.58
A4	2.49		0.82	1.34					4.65	69.42
A5	0.67			0.5					1.17	57.26
B1	1.54		1.04	1.49					4.07	60.84

B2	1.12		1.04	0.96					3.12	65.90
B3	0.68		0.73	0.47					1.88	71.12
B4	0.87			0.37					1.24	70.16
B5	0.27		0.21	0.59					1.07	42.90
B6	0.82		0.58	0.94					2.34	57.35
B7	0.61		0.26	1.42					2.29	36.86
B8	1.76			1.61					3.37	52.23
B9	0.71			0.39					1.10	64.55
C1	1.03		0.75	1.61					3.39	50.29
C2	1.02		0.71	0.64					2.37	70.00
C3	0.17			0.28					0.45	37.78
D1	2.84		0.16	4.43					7.43	40.16
D2	1.51				2.80		6.25	1.60	12.16	46.09
D3	0.31			0.92					1.23	25.20
D4	0.21			0.13					0.34	61.76
D5	0.19			1.39					1.58	12.03
E	0.58				0.63		1.28	0.72	3.21	48.40
O1		0.48		7.04					7.52	5.11
O2	0.36			0.15					0.51	70.59
O3		0.84						0.52	1.36	58.97
O4	0.51			0.23					0.74	68.92

O5	10.77					2.45	4.47	42.47	60.16	39.41
O6				0.63					0.63	0.00
O7a	3.81						12.98	48.78	65.57	30.35
O7b	2.18							15.29	17.47	34.36
O8	0.55						0.83		1.38	57.90
O9	2.28			3.62					5.90	38.64
O10	1.59	2.74	0.99	55.15					60.47	7.73
O11	2.08			0.93					3.01	69.10
O12	0.74			3.38					4.12	17.96
O13	1.91			2.75					4.66	40.99

Composite Existing - Misty Acres Fil No. 1 Pond (Basins E1 thru E3) 93.41 27.83

Composite Developed - Pond 1 (Basins A1 thru A5, O1 thru O4) 24.52 45.60

Composite Developed - Pond 2 (Basins B1 thru B9) 20.48 57.88

Composite Developed - Pond 3 (Basins C1 thru C3) 6.21 56.91

Composite Developed - Pond 4 (Basins D1 thru D5) 22.74 40.89

Pond 5 (Basin E) 3.21 48.40

Land Use	% Impervious
Streets/Drives/Walks	100
Streets - Gravel	80
Roof	90
Lawn	0
Res 1/8ac or less	65
Res 1/4ac or less	40
Res 1/3ac or less	30
Res 1/2ac or less	25

**MONUMENT RIDGE EAST
MASTER DEVELOPMENT DRAINAGE PLAN
(Composite Runoff Coefficients)**

Basin	Basin Area	Land Use	Sub-Basin (5yr)		Composite	Sub-Basin (10yr)		Composite	Sub-Basin (100yr)		Composite
	(acres)		C ₅	Area (acres)	C ₅	C ₁₀	Area (acres)	C ₁₀	C ₁₀₀	Area (acres)	C ₁₀₀
E1	31.89	Streets - Gravel	0.59	1.86	0.11	0.63	1.86	0.18	0.70	1.86	0.37
		Lawn	0.08	30.03		0.15	30.03		0.35	30.03	
E2	1.37	Streets - Gravel	0.59	0.84	0.45	0.63	0.84	0.50	0.70	0.84	0.61
		1/2 Ac	0.22	0.52		0.30	0.52		0.46	0.52	
E3	60.15	Streets/Drive/Walks	0.90	10.77	0.35	0.92	10.77	0.41	0.96	10.77	0.55
		1/4 Ac	0.30	2.45		0.36	2.45		0.50	2.45	
		1/3 Ac	0.25	4.47		0.32	4.47		0.47	4.47	
		1/2 Ac	0.22	42.47		0.30	42.47		0.46	42.47	
E4	65.56	Streets/Drive/Walks	0.90	3.81	0.27	0.92	3.81	0.34	0.96	3.81	0.49
		1/3 Ac	0.25	12.98		0.32	12.98		0.47	12.98	
		1/2 Ac	0.22	48.78		0.30	48.78		0.46	48.78	
E5	17.47	Streets/Drive/Walks	0.90	2.18	0.30	0.92	2.18	0.38	0.96	2.18	0.52
		1/2 Ac	0.22	15.29		0.30	15.29		0.46	15.29	
E6	1.38	Streets/Drive/Walks	0.90	0.55	0.51	0.92	0.55	0.56	0.96	0.55	0.67
		1/3 Ac	0.25	0.83		0.32	0.83		0.47	0.83	
E7	41.48	Streets/Drive/Walks	0.90	0.81	0.15	0.92	0.81	0.23	0.96	0.81	0.45
		1/2 Ac	0.25	5.88		0.33	5.88		0.52	5.88	
		Lawn	0.12	34.79		0.20	34.79		0.43	34.79	
E8	60.46	Streets/Drive/Walks	0.90	1.59	0.14	0.92	1.59	0.20	0.96	1.59	0.39
		Streets - Gravel	0.59	2.74		0.63	2.74		0.70	2.74	
		Roof	0.73	0.99		0.75	0.99		0.81	0.99	
		Lawn	0.08	55.15		0.15	55.15		0.35	55.15	

<i>Basin</i>	<i>Basin Area</i>	<i>Land Use</i>	<i>Sub-Basin (5yr)</i>		<i>Composite</i>	<i>Sub-Basin (10yr)</i>		<i>Composite</i>	<i>Sub-Basin (100yr)</i>		<i>Composite</i>
	<i>(acres)</i>		<i>C₅</i>	<i>Area (acres)</i>		<i>C₁₀</i>	<i>Area (acres)</i>		<i>C₁₀₀</i>	<i>Area (acres)</i>	
E9	2.92	Streets - Paved	0.90	1.72	0.56	0.92	1.72	0.60	0.96	1.72	0.71
		Lawn	0.08	1.20		0.15	1.20		0.35	1.20	
E10	13.16	Streets - Paved	0.90	1.42	0.22	0.92	1.42	0.29	0.96	1.42	0.50
		Streets - Gravel	0.61	0.40		0.65	0.40		0.72	0.40	
		Lawn	0.12	11.34		0.20	11.34		0.43	11.34	
E11	5.24	Streets - Paved	0.90	1.91	0.40	0.92	1.91	0.46	0.96	1.91	0.62
		Lawn	0.12	3.34		0.20	3.34		0.43	3.34	
A1	4.75	Streets/Drive/Walks	0.90	2.14	0.66	0.92	2.14	0.69	0.96	2.14	0.77
		Roof	0.73	1.55		0.75	1.55		0.81	1.55	
		Lawn	0.08	1.06		0.15	1.06		0.35	1.06	
A2	2.41	Streets/Drive/Walks	0.90	0.78	0.58	0.92	0.78	0.62	0.96	0.78	0.72
		Roof	0.73	0.88		0.75	0.88		0.81	0.88	
		Lawn	0.08	0.75		0.15	0.75		0.35	0.75	
A3	1.41	Streets/Drive/Walks	0.90	0.04	0.14	0.92	0.04	0.21	0.96	0.04	0.40
		Roof	0.73	0.09		0.75	0.09		0.81	0.09	
		Lawn	0.08	1.28		0.15	1.28		0.35	1.28	
A4	4.65	Streets/Drive/Walks	0.90	2.49	0.63	0.92	2.49	0.67	0.96	2.49	0.76
		Roof	0.73	0.82		0.75	0.82		0.81	0.82	
		Lawn	0.08	1.34		0.15	1.34		0.35	1.34	
A5	1.17	Streets/Drive/Walks	0.90	0.67	0.55	0.92	0.67	0.59	0.96	0.67	0.70
		Lawn	0.08	0.50		0.15	0.50		0.35	0.50	

<i>Basin</i>	<i>Basin Area</i>	<i>Land Use</i>	<i>Sub-Basin (5yr)</i>		<i>Composite</i>	<i>Sub-Basin (10yr)</i>		<i>Composite</i>	<i>Sub-Basin (100yr)</i>		<i>Composite</i>
	<i>(acres)</i>		<i>C₅</i>	<i>Area (acres)</i>		<i>C₁₀</i>	<i>Area (acres)</i>		<i>C₁₀₀</i>	<i>Area (acres)</i>	
B1	4.07	Streets/Drive/Walks	0.90	1.54	0.56	0.92	1.54	0.59	0.96	1.54	0.70
		Roof	0.73	1.04		0.75	1.04		0.81	1.04	
		Lawn	0.08	1.49		0.15	1.49		0.35	1.49	
B2	3.12	Streets/Drive/Walks	0.90	1.12	0.59	0.92	1.12	0.63	0.96	1.12	0.72
		Roof	0.73	1.04		0.75	1.04		0.81	1.04	
		Lawn	0.08	0.96		0.15	0.96		0.35	0.96	
B3	1.88	Streets/Drive/Walks	0.90	0.68	0.63	0.92	0.68	0.66	0.96	0.68	0.75
		Roof	0.73	0.73		0.75	0.73		0.81	0.73	
		Lawn	0.08	0.47		0.15	0.47		0.35	0.47	
B4	1.24	Streets/Drive/Walks	0.90	0.87	0.66	0.92	0.87	0.69	0.96	0.87	0.78
		Lawn	0.08	0.37		0.15	0.37		0.35	0.37	
B5	1.07	Streets/Drive/Walks	0.90	0.27	0.41	0.92	0.27	0.46	0.96	0.27	0.59
		Roof	0.73	0.21		0.75	0.21		0.81	0.21	
		Lawn	0.08	0.59		0.15	0.59		0.35	0.59	
B6	2.34	Streets/Drive/Walks	0.90	0.82	0.53	0.92	0.82	0.57	0.96	0.82	0.68
		Roof	0.73	0.58		0.75	0.58		0.81	0.58	
		Lawn	0.08	0.94		0.15	0.94		0.35	0.94	
B7	2.29	Streets/Drive/Walks	0.90	0.61	0.37	0.92	0.61	0.42	0.96	0.61	0.56
		Roof	0.73	0.26		0.75	0.26		0.81	0.26	
		Lawn	0.08	1.42		0.15	1.42		0.35	1.42	

Basin	Basin Area	Land Use	Sub-Basin (5yr)		Composite	Sub-Basin (10yr)		Composite	Sub-Basin (100yr)		Composite
	(acres)		C ₅	Area (acres)		C ₅	C ₁₀		Area (acres)	C ₁₀	
B8	3.37	Streets/Drive/Walks	0.90	1.76	0.51	0.92	1.76	0.55	0.96	1.76	0.67
		Lawn	0.08	1.61		0.15	1.61		0.35	1.61	
B9	1.10	Pond	0.90	0.71	0.63	0.92	0.71	0.68	0.96	0.71	0.80
		Lawn	0.15	0.39		0.25	0.39		0.50	0.39	
C1	3.52	Streets/Drive/Walks	0.90	1.03	0.52	0.92	1.03	0.58	0.96	1.03	0.72
		Roof	0.75	0.88		0.77	0.88		0.83	0.88	
		Lawn	0.15	1.61		0.25	1.61		0.50	1.61	
C2	2.37	Streets/Drive/Walks	0.90	1.02	0.65	0.92	1.02	0.69	0.96	1.02	0.80
		Roof	0.75	0.71		0.77	0.71		0.83	0.71	
		Lawn	0.15	0.64		0.25	0.64		0.50	0.64	
C3	0.45	Pond	0.90	0.17	0.39	0.92	0.17	0.44	0.96	0.17	0.58
		Lawn	0.08	0.28		0.15	0.28		0.35	0.28	
D1	7.45	Streets/Drive/Walks	0.90	2.84	0.43	0.92	2.84	0.49	0.96	2.84	0.64
		Roof	0.74	0.18		0.76	0.18		0.82	0.18	
		Lawn	0.12	4.43		0.20	4.43		0.43	4.43	
D2	12.16	Streets/Drive/Walks	0.90	1.51	0.40	0.92	1.51	0.46	0.96	1.51	0.61
		1/8 Ac or Less	0.48	2.80		0.52	2.80		0.63	2.80	
		1/3 Ac	0.28	6.25		0.35	6.25		0.53	6.25	
		1/2 Ac	0.25	1.60		0.33	1.60		0.52	1.60	
D3	1.23	Streets/Drive/Walks	0.90	0.31	0.29	0.92	0.31	0.34	0.96	0.31	0.50
		Lawn	0.08	0.92		0.15	0.92		0.35	0.92	
D4	0.34	Streets/Drive/Walks	0.90	0.21	0.59	0.92	0.21	0.63	0.96	0.21	0.73
		Lawn	0.08	0.13		0.15	0.13		0.35	0.13	
D5	1.58	Pond	0.90	0.19	0.21	0.92	0.19	0.29	0.96	0.19	0.49
		Lawn	0.12	1.39		0.20	1.39		0.43	1.39	

Basin	Basin Area	Land Use	Sub-Basin (5yr)		Composite	Sub-Basin (10yr)		Composite	Sub-Basin (100yr)		Composite
	(acres)		C ₅	Area (acres)		C ₁₀	Area (acres)		C ₁₀₀	Area (acres)	
E	3.21	Streets/Drive/Walks	0.90	0.58	0.42	0.92	0.58	0.48	0.96	0.58	0.63
		1/8 Ac or Less	0.48	0.63		0.52	0.63		0.63	0.63	
		1/3 Ac	0.28	1.28		0.35	1.28		0.53	1.28	
		1/2 Ac	0.25	0.72		0.33	0.72		0.52	0.72	
O1	7.52	Streets - Gravel	0.59	0.48	0.11	0.63	0.48	0.18	0.70	0.48	0.37
		Lawn	0.08	7.04		0.15	7.04		0.35	7.04	
O2	0.51	Streets/Drive/Walks	0.90	0.36	0.66	0.92	0.36	0.69	0.96	0.36	0.78
		Lawn	0.08	0.15		0.15	0.15		0.35	0.15	
O3	1.37	Streets - Gravel	0.59	0.84	0.45	0.63	0.84	0.50	0.70	0.84	0.61
		1/2 Ac	0.22	0.52		0.30	0.52		0.46	0.52	
O4	0.74	Streets/Drive/Walks	0.90	0.51	0.64	0.92	0.51	0.68	0.96	0.51	0.77
		Lawn	0.08	0.23		0.15	0.23		0.35	0.23	
O5	60.15	Streets/Drive/Walks	0.90	10.77	0.35	0.92	10.77	0.41	0.96	10.77	0.55
		1/4 Ac	0.30	2.45		0.36	2.45		0.50	2.45	
		1/3 Ac	0.25	4.47		0.32	4.47		0.47	4.47	
		1/2 Ac	0.22	42.47		0.30	42.47		0.46	42.47	
O6	0.63	Lawn	0.15	0.63	0.15	0.25	0.63	0.25	0.50	0.63	0.50
O7a	65.56	Streets/Drive/Walks	0.90	3.81	0.27	0.92	3.81	0.34	0.96	3.81	0.49
		1/3 Ac	0.25	12.98		0.32	12.98		0.47	12.98	
		1/2 Ac	0.22	48.78		0.30	48.78		0.46	48.78	
O7b	18.40	Streets/Drive/Walks	0.90	2.18	0.30	0.92	2.18	0.37	0.96	2.18	0.52
		1/2 Ac	0.22	16.22		0.30	16.22		0.46	16.22	
O8	1.38	Streets/Drive/Walks	0.90	0.55	0.51	0.92	0.55	0.56	0.96	0.55	0.67
		1/3 Ac	0.25	0.83		0.32	0.83		0.47	0.83	
O9	5.90	Streets and Pond	0.90	2.28	0.42	0.92	2.28	0.48	0.96	2.28	0.63
		Lawn	0.12	3.62		0.20	3.62		0.43	3.62	

<i>Basin</i>	<i>Basin Area</i>	<i>Land Use</i>	<i>Sub-Basin (5yr)</i>		<i>Composite</i>	<i>Sub-Basin (10yr)</i>		<i>Composite</i>	<i>Sub-Basin (100yr)</i>		<i>Composite</i>
	<i>(acres)</i>		<i>C₅</i>	<i>Area (acres)</i>		<i>C₁₀</i>	<i>Area (acres)</i>		<i>C₁₀₀</i>	<i>Area (acres)</i>	
O10	60.46	Streets/Drive/Walks	0.90	1.59	0.14	0.92	1.59	0.20	0.96	1.59	0.39
		Streets - Gravel	0.59	2.74		0.63	2.74		0.70	2.74	
		Roof	0.73	0.99		0.75	0.99		0.81	0.99	
		Lawn	0.08	55.15		0.15	55.15		0.35	55.15	
O11	3.00	Streets/Drive/Walks	0.90	2.08	0.65	0.92	2.08	0.68	0.96	2.08	0.77
		Lawn	0.08	0.93		0.15	0.93		0.35	0.93	
O12	4.12	Streets/Drive/Walks	0.90	0.74	0.28	0.92	0.74	0.37	0.96	0.74	0.58
		Lawn	0.15	3.38		0.25	3.38		0.50	3.38	
O13	4.66	Streets/Drive/Walks	0.90	1.91	0.44	0.92	1.91	0.49	0.96	1.91	0.65
		Lawn	0.12	2.75		0.20	2.75		0.43	2.75	

Notes:

1. Shaded cells indicate composite runoff coefficients with 1/2 HSG B and 1/2 HSG D.
2. All basins split between the two soil groups are 1/2 HSG D or less (i.e. - conservative approach).

**MONUMENT RIDGE EAST
MASTER DEVELOPMENT DRAINAGE PLAN
(Basin Runoff Calculations)**

					Overland Flow				Channel Flow					Travel Time (T_t)	Intensity		Total Flows	
Basin	Area Total (acres)	C_5	C_{10}	C_{100}	C_5	Length (ft)	Slope (ft/ft)	T_c (min)	Length (ft)	Slope (ft/ft)	C_v	Velocity (fps)	T_t (min)	TOTAL* (min)	I_{10} (in/hr)	I_{100} (in/hr)	Q_{10} (c.f.s.)	Q_{100} (c.f.s.)
E1	31.89	0.11	0.18	0.37	0.11	300	0.076	15.9	1060	0.035	15	2.8	6.3	22.2	3.4	4.9	19.4	58.2
E2	1.37	0.45	0.50	0.61	0.45	300	0.083	10.1						10.1	4.8	6.9	3.3	5.7
E3	60.15	0.35	0.41	0.55	0.35	100	0.052	7.9	1370	0.065	15	3.8	6.0	13.9	4.2	6.1	106.0	202.8
E4	65.56	0.27	0.34	0.49	0.27	100	0.12	6.6	1935	0.07	15	4.0	8.1	14.8	4.1	6.0	92.2	191.6
E5	17.47	0.30	0.38	0.52	0.30	100	0.102	6.7	840	0.105	15	4.9	2.9	9.6	4.9	7.0	32.3	64.3
E6	1.38	0.51	0.56	0.67										5.0	6.0	8.7	4.7	8.0
E7	41.48	0.15	0.23	0.45	0.15	300	0.065	16.0	1610	0.031	15	2.6	10.2	26.1	3.1	4.5	30.3	84.8
E8	60.46	0.14	0.20	0.39	0.14	300	0.077	15.4	1480	0.044	15	3.1	7.8	23.2	3.3	4.8	40.8	113.2
E9	2.92	0.56	0.60	0.71										5.0	6.0	8.7	10.6	18.0

					<i>Overland Flow</i>				<i>Channel Flow</i>					<i>Travel Time (T_t)</i>	<i>Intensity</i>		<i>Total Flows</i>	
<i>Basin</i>	<i>Area Total (acres)</i>	<i>C₅</i>	<i>C₁₀</i>	<i>C₁₀₀</i>	<i>C₅</i>	<i>Length (ft)</i>	<i>Slope (ft/ft)</i>	<i>T_c (min)</i>	<i>Length (ft)</i>	<i>Slope (ft/ft)</i>	<i>C_v</i>	<i>Velocity (fps)</i>	<i>T_t (min)</i>	<i>TOTAL* (min)</i>	<i>I₁₀ (in/hr)</i>	<i>I₁₀₀ (in/hr)</i>	<i>Q₁₀ (c.f.s.)</i>	<i>Q₁₀₀ (c.f.s.)</i>
E10	13.16	0.22	0.29	0.50	0.22	230	0.078	12.2	810	0.027	15	2.5	5.5	17.7	3.8	5.5	14.6	35.8
E11	5.24	0.40	0.46	0.62	0.40	100	0.04	8.0	1115	0.032	15	2.7	6.9	14.9	4.1	5.9	10.0	19.4
A1	4.75	0.66	0.69	0.77										5.0	6.0	8.7	19.8	31.9
A2	2.41	0.58	0.62	0.72										5.0	6.0	8.7	9.0	15.0
A3	1.41	0.14	0.21	0.40	0.14	100	0.022	13.3						13.3	4.3	6.2	1.3	3.5
A4	4.65	0.63	0.67	0.76										5.0	6.0	8.7	18.7	30.6
A5	1.17	0.55	0.59	0.70										5.0	6.0	8.7	4.2	7.1
B1	4.07	0.56	0.59	0.70										5.0	6.0	8.7	14.6	24.7
B2	3.12	0.59	0.63	0.72										5.0	6.0	8.7	11.8	19.6
B3	1.88	0.63	0.66	0.75										5.0	6.0	8.7	7.5	12.2
B4	1.24	0.66	0.69	0.78										5.0	6.0	8.7	5.2	8.4

					<i>Overland Flow</i>				<i>Channel Flow</i>					<i>Travel Time (T_t)</i>	<i>Intensity</i>		<i>Total Flows</i>	
<i>Basin</i>	<i>Area Total (acres)</i>	<i>C₅</i>	<i>C₁₀</i>	<i>C₁₀₀</i>	<i>C₅</i>	<i>Length (ft)</i>	<i>Slope (ft/ft)</i>	<i>T_c (min)</i>	<i>Length (ft)</i>	<i>Slope (ft/ft)</i>	<i>C_v</i>	<i>Velocity (fps)</i>	<i>T_t (min)</i>	<i>TOTAL* (min)</i>	<i>I₁₀ (in/hr)</i>	<i>I₁₀₀ (in/hr)</i>	<i>Q₁₀ (c.f.s.)</i>	<i>Q₁₀₀ (c.f.s.)</i>
B5	1.07	0.41	0.46	0.59	0.41	100	0.098	5.8						5.8	5.8	8.3	2.8	5.3
B6	2.34	0.53	0.57	0.68	0.53	90	0.089	4.8	340	0.033	20	3.6	1.6	6.3	5.6	8.1	7.5	12.8
B7	2.29	0.37	0.42	0.56	0.37	95	0.180	4.9	690	0.029	20	3.4	3.4	8.3	5.1	7.4	5.0	9.6
B8	3.37	0.51	0.55	0.67	0.51	95	0.126	4.5	130	0.01	20	2.0	1.1	5.6	5.8	8.4	10.9	18.9
B9	1.10	0.63	0.68	0.80										5.0	6.0	8.7	4.5	7.6
C1	3.52	0.52	0.58	0.72										5.0	6.0	8.7	12.2	21.9
C2	2.37	0.65	0.69	0.80										5.0	6.0	8.7	9.9	16.4
C3	0.45	0.39	0.44	0.58										5.0	6.0	8.7	1.2	2.3
D1	7.45	0.43	0.49	0.64	0.43	100	0.093	5.8	580	0.029	20	3.4	2.8	8.6	5.1	7.3	18.5	34.9

					<i>Overland Flow</i>				<i>Channel Flow</i>					<i>Travel Time (T_t)</i>	<i>Intensity</i>		<i>Total Flows</i>	
<i>Basin</i>	<i>Area Total (acres)</i>	<i>C₅</i>	<i>C₁₀</i>	<i>C₁₀₀</i>	<i>C₅</i>	<i>Length (ft)</i>	<i>Slope (ft/ft)</i>	<i>T_c (min)</i>	<i>Length (ft)</i>	<i>Slope (ft/ft)</i>	<i>C_v</i>	<i>Velocity (fps)</i>	<i>T_t (min)</i>	<i>TOTAL* (min)</i>	<i>I₁₀ (in/hr)</i>	<i>I₁₀₀ (in/hr)</i>	<i>Q₁₀ (c.f.s.)</i>	<i>Q₁₀₀ (c.f.s.)</i>
D2	12.16	0.40	0.46	0.61	0.40	100	0.130	5.4	1050	0.0152	20	2.5	7.1	12.5	4.4	6.4	24.6	46.8
D3	1.23	0.29	0.34	0.50										5.0	6.0	8.7	2.6	5.4
D4	0.34	0.59	0.63	0.73										5.0	6.0	8.7	1.3	2.1
D5	1.58	0.21	0.29	0.49										5.0	6.0	8.7	2.7	6.8
E	3.21	0.42	0.48	0.63										5.0	6.0	8.7	9.3	17.4
O1	7.52	0.11	0.18	0.37	0.11	130	0.080	10.2	480	0.054	10	2.3	3.4	13.7	4.3	6.1	5.8	17.2
O2	0.51	0.66	0.69	0.78										5.0	6.0	8.7	2.1	3.5
O3	1.37	0.45	0.50	0.61	0.45	300	0.083	10.1						10.1	4.8	6.9	3.3	5.7
O4	0.74	0.64	0.68	0.77										5.0	6.0	8.7	3.0	4.9
O5	60.15	0.35	0.41	0.55	0.35	100	0.052	7.9	1370	0.065	15	3.8	6.0	13.9	4.2	6.1	106.0	202.8

					<i>Overland Flow</i>				<i>Channel Flow</i>					<i>Travel Time (T_t)</i>	<i>Intensity</i>		<i>Total Flows</i>	
<i>Basin</i>	<i>Area Total (acres)</i>	<i>C₅</i>	<i>C₁₀</i>	<i>C₁₀₀</i>	<i>C₅</i>	<i>Length (ft)</i>	<i>Slope (ft/ft)</i>	<i>T_c (min)</i>	<i>Length (ft)</i>	<i>Slope (ft/ft)</i>	<i>C_v</i>	<i>Velocity (fps)</i>	<i>T_t (min)</i>	<i>TOTAL* (min)</i>	<i>I₁₀ (in/hr)</i>	<i>I₁₀₀ (in/hr)</i>	<i>Q₁₀ (c.f.s.)</i>	<i>Q₁₀₀ (c.f.s.)</i>
O6	0.63	0.15	0.25	0.50										5.0	6.0	8.7	1.0	2.7
O7a	65.56	0.27	0.34	0.49	0.27	100	0.120	6.6	1935	0.070	15	4.0	8.1	14.8	4.1	6.0	92.2	191.6
O7b	18.40	0.30	0.37	0.52	0.30	100	0.102	6.7	840	0.105	15	4.9	2.9	9.6	4.9	7.0	33.6	67.2
O8	1.38	0.51	0.56	0.67										5.0	6.0	8.7	4.7	8.0
O9	5.90	0.42	0.48	0.63	0.42	245	0.049	11.4	330	0.036	15	2.8	1.9	13.3	4.3	6.2	12.2	23.3
O10	60.46	0.14	0.20	0.39	0.14	300	0.077	15.4	1480	0.044	15	3.1	7.8	23.2	3.3	4.8	40.8	113.2
O11	3.00	0.65	0.68	0.77										5.0	6.0	8.7	12.4	20.1
O12	4.12	0.28	0.37	0.58	0.28	180	0.044	12.1	200	0.056	15	3.5	0.9	13.1	4.4	6.3	6.6	15.0
O13	4.66	0.44	0.49	0.65	0.44	100	0.040	7.6	1115	0.032	15	2.7	6.9	14.5	4.2	6.0	9.6	18.1

* 5 MINUTE TIME OF CONCENTRATION - MINIMUM

**MONUMENT RIDGE EAST
MASTER DEVELOPMENT DRAINAGE PLAN
(Surface Routing Summary)**

Design Point	Design Point/ Contributing Basins	Equivalent CA ₁₀	Equivalent CA ₁₀₀	Routed T _C	Intensity		Flow		Comments
					I ₁₀	I ₁₀₀	Q ₁₀	Q ₁₀₀	
1	E2	0.69	0.83	10.1	4.8	6.9	3.3	5.7	existing 36" RCP culvert
2	DP1,E1	6.36	12.64	22.2	3.4	4.9	21.8	62.2	existing dual 48" RCP culverts
3	DP2,E3	31.32	45.84	22.2	3.4	4.9	107.2	225.6	Misty Ac 1 Pond Attenuation of Q10=58cfs, Q100=130cfs (per MDDP), yields Q10out=49.2cfs and Q100=95.6cfs)
4	E4	22.29	32.19	14.8	4.1	5.9	92.1	191.4	unk pipe sizes, assume no peak flow attenuation
5	DP4,E5	28.88	41.32	18.0	3.8	5.5	109.4	225.2	low point collection structure, size TBD in FDR
6	DP3 (attenuated),DP5,E6,E7	existing wetland/depression area					214.3	488.0	existing 48" CMP culvert, overtops road
7	E8	12.20	23.54	23.2	3.3	4.8	40.8	113.3	existing 48" CMP culvert
8	DP7,E9,E10	17.79	32.14	28.7	3.0	4.3	52.9	137.4	existing 48" RCP culvert, overtop elev unk
9	DP8,E11	20.21	35.41	28.7	3.0	4.3	60.1	151.4	existing 48" RCP culvert, overtop elev unk
10	E6	0.77	0.92	5.0	6.0	8.7	4.7	8.0	existing 24" culvert
11	O1	1.36	2.80	13.7	4.3	6.1	5.8	17.2	proposed 18" RCP
12	O2	0.35	0.40	5.0	6.0	8.7	2.1	3.5	existing type C inlet
13A	A1(30%)	0.99	1.10	5.0	6.0	8.7	6.0	9.6	proposed 2-4' D-10-R inlets
13B	DP12,A1(70%)	2.66	2.97	5.0	6.0	8.7	16.0	25.8	proposed 2-16' D-10-R inlets
14	A2	1.49	1.72	5.0	6.0	8.7	9.0	15.0	split w/DP13 flows, proposed 4' and 16' D-10-R inlets
15	O3	0.69	0.83	10.1	4.8	6.9	3.3	5.7	existing 36" RCP culvert
16	O4	0.50	0.57	5.0	6.0	8.7	3.0	4.9	existing type C inlet
17	DP15,DP16	1.19	1.40	10.1	4.8	6.9	5.7	9.7	proposed 18" RCP culvert

18	DP13A, DP13B,DP14,DP17	pipe flow junction, for reference only					36.7	60.0	proposed manhole
19	DP11,A3	0.30	0.56	13.3	4.3	6.2	7.1	20.7	proposed 18" RCP culvert
20	A4	3.11	3.52	5.0	6.0	8.7	18.7	30.6	proposed 2-12' D-10-R inlets
21	DP18,DP19	storm system outfall location, for reference only					43.8	80.7	flow to pond 1, unrouted
22	DP20,DP21,A5	extended detention basin, pond 1					66.7	118.4	total flow to pond 1, not routed
23	B1	2.42	2.84	5.0	6.0	8.7	14.6	24.7	proposed 2-8' D-10-R inlets
24	B2	1.95	2.25	5.0	6.0	8.7	11.8	19.6	split w/DP25 flows, proposed triple type R inlets
25	B3	1.24	1.41	5.0	6.0	8.7	7.5	12.2	split w/DP24 flows, proposed triple type R inlets
26	DP23,DP24,DP25	pipe flow junction, for reference only					33.9	56.5	proposed manhole
27	B8	1.86	2.25	5.6	5.8	8.4	10.9	18.9	proposed 2-8' D-10-R inlets
28	B4(60%)	0.51	0.58	5.0	6.0	8.7	3.1	5.0	proposed double type 16 inlet
29A	B4(40%)	0.34	0.39	5.0	6.0	8.7	2.1	3.3	proposed double type 16 inlet
29B	DP26,DP27,DP28,DP29A	pipe flow junction, for reference only					49.9	83.7	proposed manhole
30	B5(33%)	0.16	0.21	5.8	5.8	8.3	1.0	1.8	proposed single type R inlet
31	B5(66%)	0.33	0.42	5.8	5.8	8.3	1.9	3.5	proposed single type R inlet
32	B6	1.33	1.59	6.3	5.6	8.1	7.5	12.8	proposed double type R inlet
33	B7	0.97	1.29	7.9	5.2	7.5	5.1	9.7	proposed double type R inlet
34	DP23,DP24,DP25,DP27,DP28,DP29,DP30,DP31,DP32,DP33,B9	extended detention basin, pond 2					69.8	119.2	total flow to pond 2, not routed
35	C1	2.03	2.52	5.0	6.0	8.7	12.2	21.9	split w/DP36 flows, proposed triple type R inlets
36	C2	1.65	1.89	5.0	6.0	8.7	9.9	16.4	split w/DP35 flows, proposed triple type R inlets
37	DP35,DP36,C3	extended detention basin, pond 3					23.3	40.6	total flow to pond 3, not routed
38	Pond 2 out, Pond 3 out	pipe flow junction, for reference only					12.7	37.9	proposed manhole
39	D1	3.64	4.78	8.6	5.1	7.3	18.5	34.9	proposed 2-16' D-10-R inlets
40a	D2(25%)	1.39	1.84	6.0	5.7	8.2	7.9	15.1	split w/DP40b flows, proposed 12' D-10-R inlet
40b	D2(25%)	1.39	1.84	6.0	5.7	8.2	7.9	15.1	split w/DP40a flows, proposed 12' D-10-R inlet

40c	D2(50%)	2.78	3.68	12.5	4.4	6.4	12.3	23.4	proposed 2-12' D-10-R inlets
41	DP39,DP40a,DP40b,DP40c, D5(50%)	extended detention basin, pond 4 (south)					48.0	92.0	total flow to pond 4 (south side)
42	D3	0.42	0.62	5.0	6.0	8.7	2.6	5.4	split with DP43 flows, proposed 4' D-10-R inlet
43	D4	0.21	0.25	5.0	6.0	8.7	1.3	2.1	split with DP42 flows, proposed 4' D-10-R inlet
44	DP42,DP43,D5(50%)	extended detention basin, pond 4 (north)					5.2	10.9	total flow to pond 4 (south side)
45	DP38, Pond 4 out	pipe flow junction, for reference only					28.8	77.3	proposed manhole
46	E	1.55	2.01	5.0	6.0	8.7	9.3	17.4	proposed 16' D-10-R inlet
47	Pond 5 outfall	extended detention basin, pond 5					2.1	5.5	total flow release
48	Pond 1 out,O5	total flow to existing Misty Acres pond					118.9	238.3	Misty Ac 1 Pond Attenuation of Q10=58cfs, Q100=130cfs (per MDDP), yields Q10out=60.9cfs and Q100=108.3cfs
49	O6	0.16	0.32	5.0	6.0	8.7	1.0	2.7	proposed type C inlet
50	O7A	22.29	32.19	14.8	4.1	5.9	92.1	191.4	total flow to existing pond, no peak flow attenuation
51	DP50,O7B	29.16	41.74	18.0	3.8	5.5	110.5	227.6	existing dual 48" CMP culverts
52	DP51	29.16	41.74	21.0	3.5	5.1	102.6	211.3	low point collection structure, size TBD in FDR
53	O8	0.77	0.92	5.0	6.0	8.7	4.7	8.0	ex culvert, size unk
54	DP45,DP47,DP48 OUT,DP49,DP52,DP53,O9	existing wetland/depression area					212.2	436.4	total inflow
55	DP54 Pipe Out	for reference only, see report					212.2	436.4	existing 48" culvert outfall, add 2-48" RCP's
56	O10	12.20	23.54	23.2	3.3	4.8	40.8	113.3	existing 48" CMP culvert
57	DP56,O11	14.25	25.86	23.2	3.3	4.8	47.7	124.4	existing type C inlet
58	DP57,O12	15.77	28.26	24.1	3.3	4.7	51.7	133.3	existing 48" RCP culvert
59	DP58,O13	18.08	31.27	24.1	3.3	4.7	59.3	147.5	existing 48" RCP culvert

**MONUMENT RIDGE EAST
 MASTER DEVELOPMENT DRAINAGE PLAN
 (Pipe Summary)**

<i>Pipe ID</i>	<i>Flow (cfs)</i>		<i>Pipe Diam (in)</i>
	<i>Q₁₀</i>	<i>Q₁₀₀</i>	
1A	5.8	17.2	30" RCP
1B	5.8	17.2	30" RCP
1C	5.8	17.2	30" RCP
1D	5.8	17.2	30" RCP
1E	6.0	9.6	18" RCP
2	22.0	35.4	30" RCP
3	9.0	15.0	24" RCP
4	31.0	50.4	36" RCP
5	5.7	9.7	18" RCP
6	5.7	9.7	18" RCP
7	36.7	60.0	36" RCP
8	7.1	20.7	18" RCP
9	NOT USED		
10	NOT USED		
11	9.4	15.3	24" RCP
12	18.7	30.6	24" RCP
13A	7.3	12.3	24" RCP
13B	14.6	24.7	30" RCP
14	7.3	12.3	24" RCP
15	11.8	19.6	24" RCP
16	7.5	12.2	24" RCP
17	19.3	31.8	30" RCP
18	26.6	44.1	36" RCP
19	5.4	9.5	24" RCP
20	10.9	18.9	24" RCP

21	42.6	71.4	42" RCP
22	69.2	115.5	42" RCP
23	1.0	1.8	18" RCP
24	1.9	3.5	18" RCP
25	2.9	5.3	18" RCP
26	7.5	12.8	24" RCP
27	10.3	18.1	24" RCP
28	15.4	27.9	24" RCP
29	10.6	28.3	24" RCP
30	12.2	21.9	30" RCP
31	22.1	38.3	36" RCP
32	2.1	5.6	18" RCP
33	12.7	33.9	36" RCP
34	12.7	33.9	36" RCP
35	9.2	17.5	24" RCP
36	18.5	34.9	30" RCP
37A	7.9	15.1	24" RCP
37B	15.9	30.2	30" RCP
37C	6.2	11.7	18" RCP
37D	22.0	42.0	30" RCP
38	28.2	53.7	36" RCP
39	2.6	5.4	18" RCP
40	3.8	7.5	24" RCP
41	16.1	39.4	36" RCP
42	28.8	73.3	42" RCP
43	9.3	17.4	24" RCP
44	2.1	5.5	18" RCP
45	60.9	108.3	54" RCP
46	61.9	111.0	54" RCP
47	61.9	111.0	54" RCP
48	164.5	322.3	78" RCP
49	164.5	322.3	78" RCP

Figure 8-10. Inlet Capacity Chart Sump Conditions, Area (Type C) Inlet

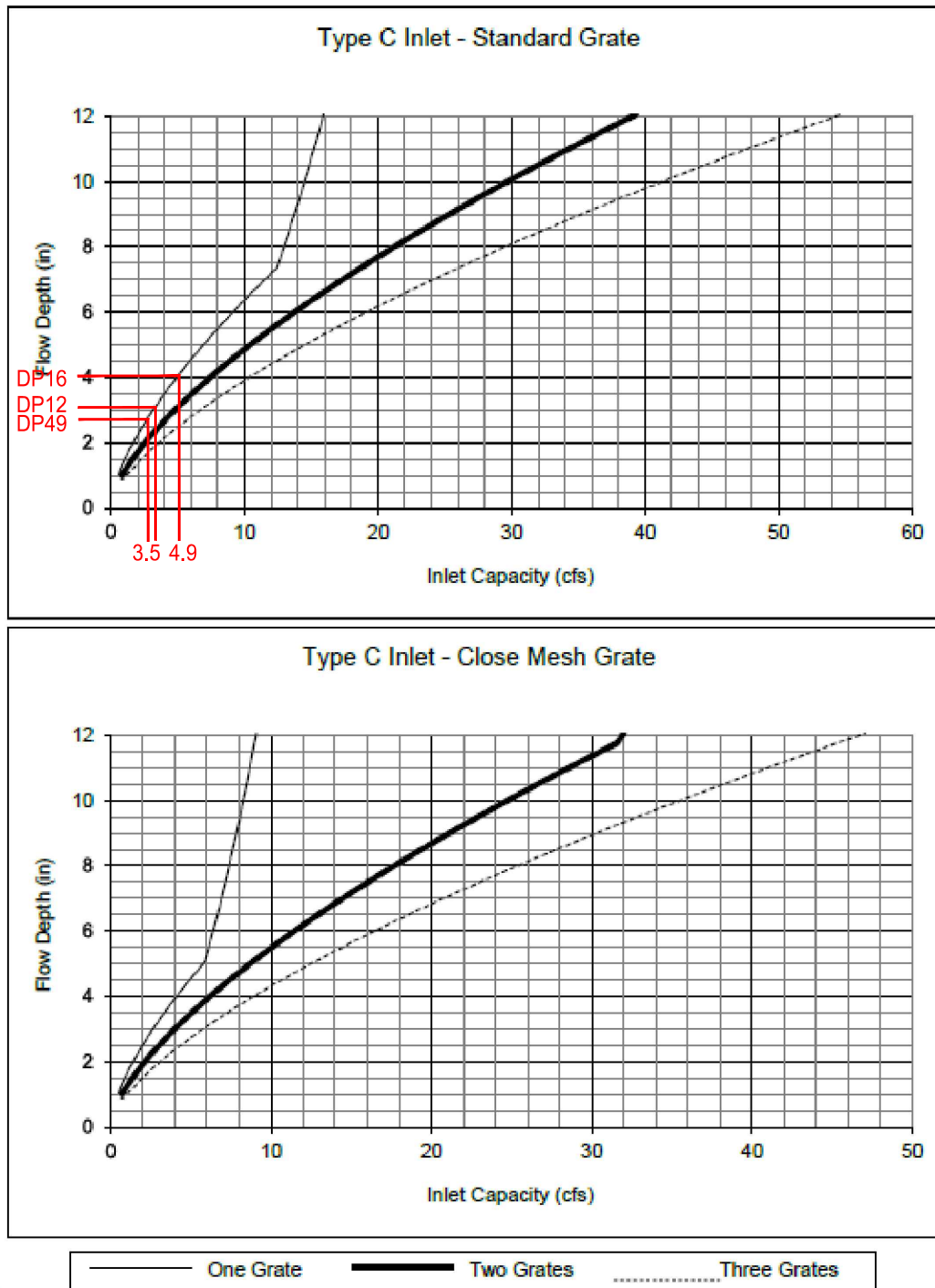

Notes:

1. The standard inlet parameters must apply to use these charts.

Figure 8-12. Inlet Capacity Chart Sump Conditions, Curb Opening (D-10-R) Inlet

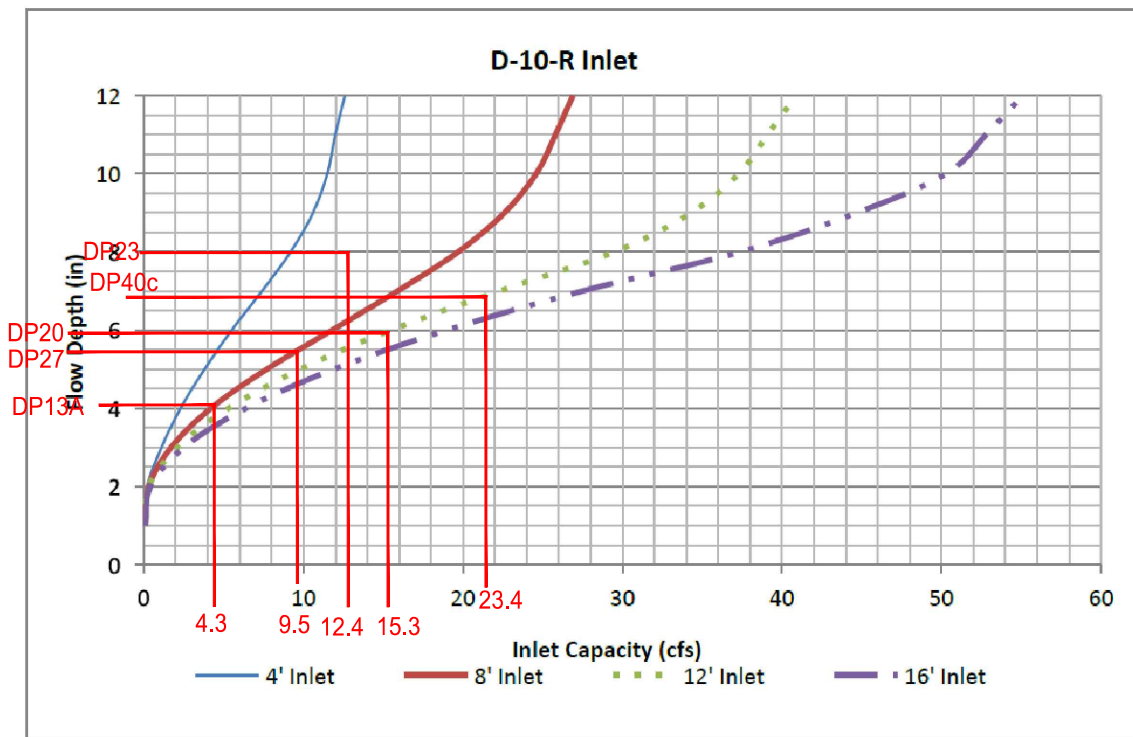

Figure 8-12. Inlet Capacity Chart Sump Conditions, Curb Opening (D-10-R) Inlet

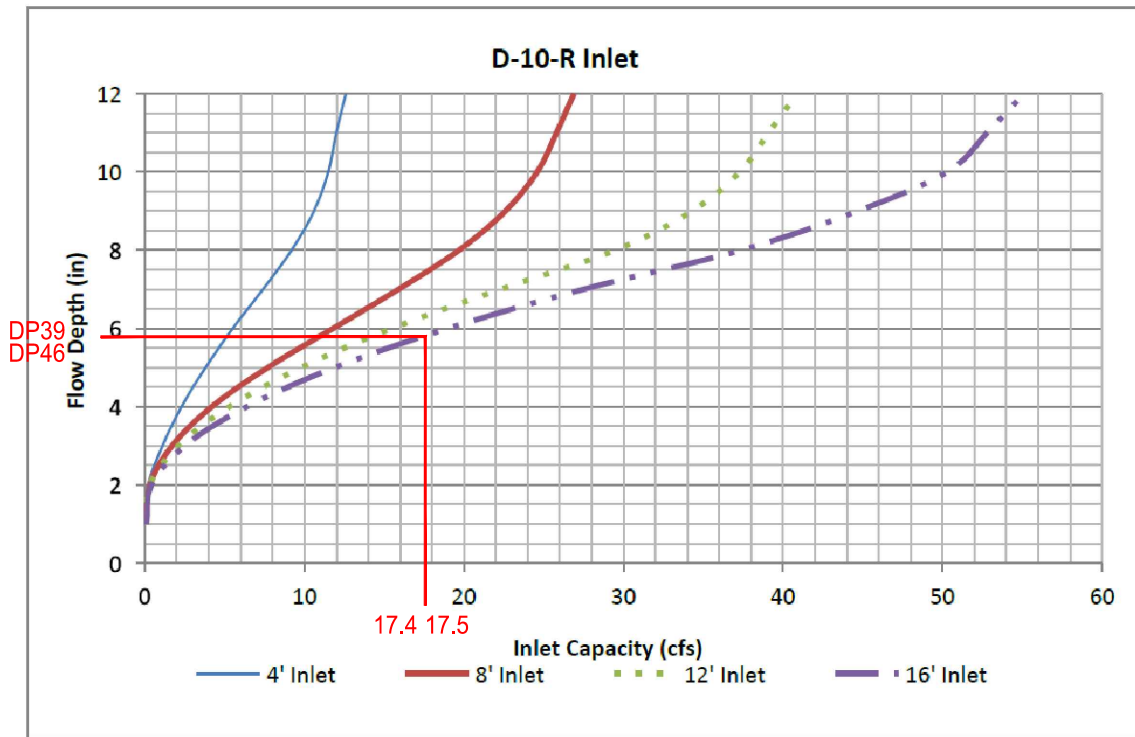
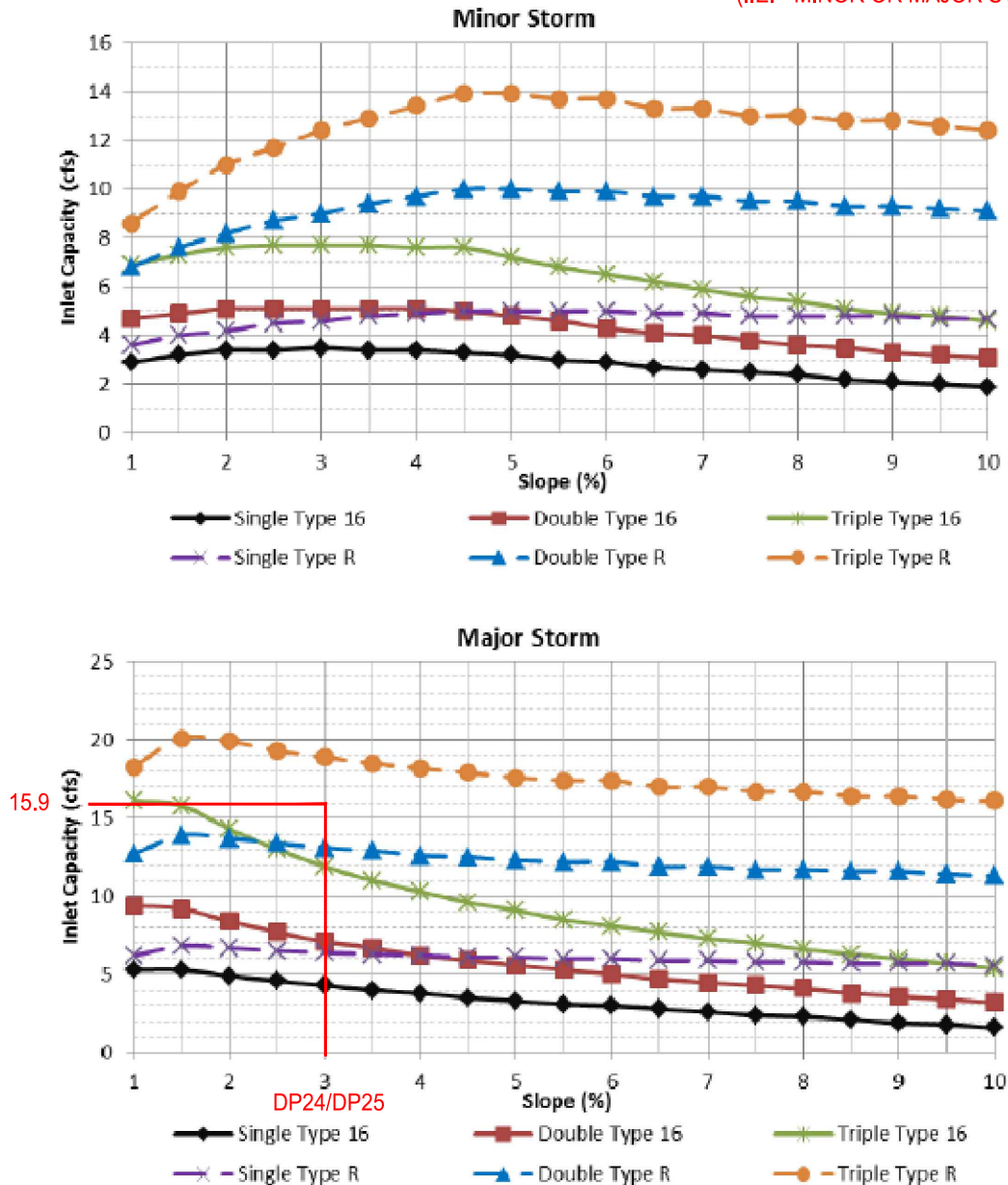

Figure 8-8. Inlet Capacity Chart Continuous Grade Conditions, Minor Residential (Local) (Detached Sidewalk)

Street Section Data: Street Width Flowline to Flowline = 32'
 Type of Curb and Gutter = 6" vertical

FLows LABELED FOR
 INLET SIZE THAT CONTROLS
 (I.E. - MINOR OR MAJOR STORM)



The standard street section parameters as defined in Chapter 7 must apply to use these charts. For non-standard sections, the inlet capacity shall be calculated using the UDFCD spreadsheets. The maximum spread width is limited by the curb height based on no curb overtopping during a minor storm and flow being contained within the public right-of-way during the major storm. Calculations were done using UD-Inlet 3.00.xls, Mar., 2011 with the default clogging factors.

Figure 8-7. Inlet Capacity Chart Continuous Grade Conditions, Residential (Local)
(Attached and Detached Sidewalk)

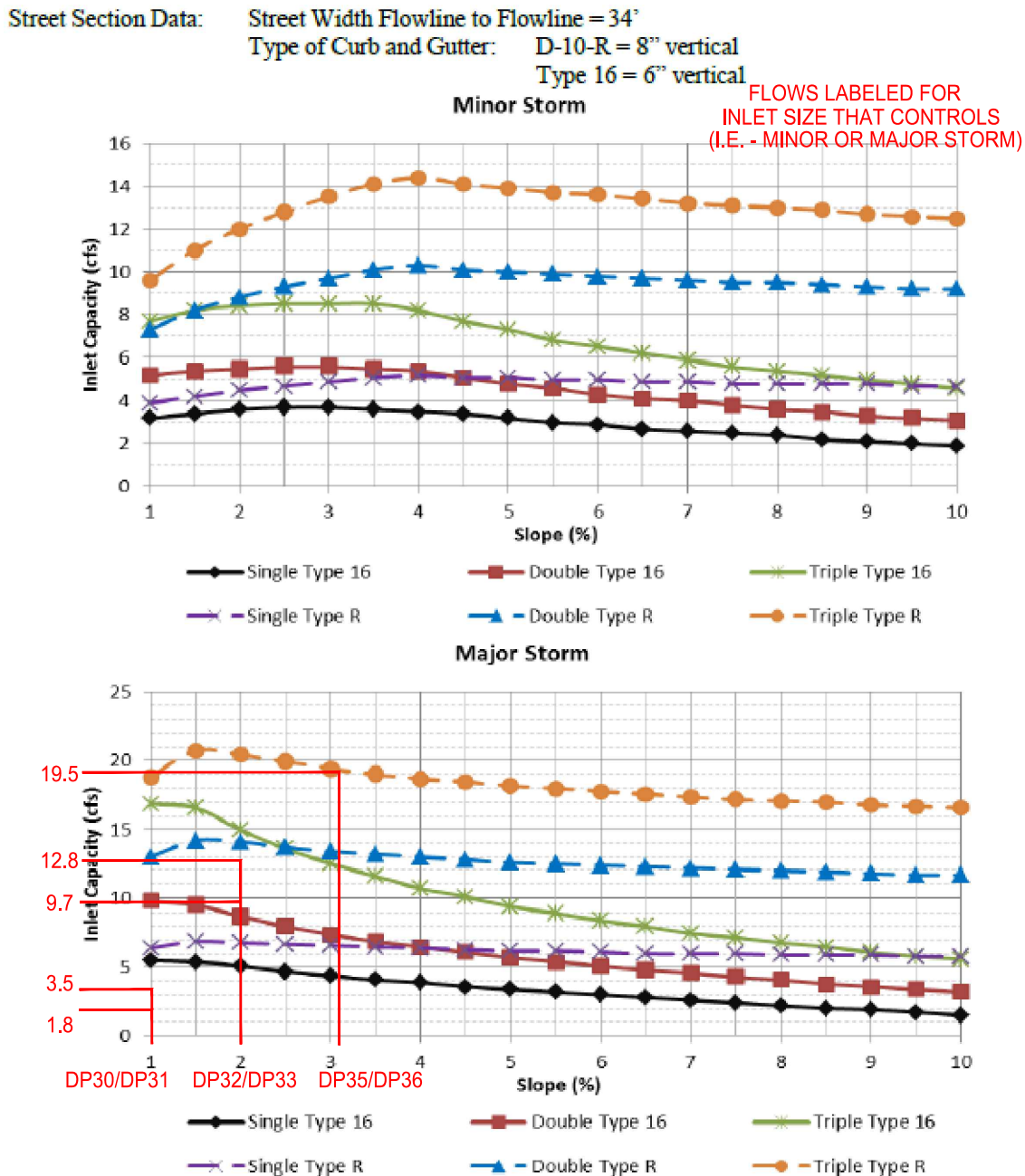

The standard street section parameters as defined in Chapter 7 must apply to use these charts. For non-standard sections, the inlet capacity shall be calculated using the UDFCD spreadsheets. The maximum spread width is limited by the curb height based on no curb overtopping during a minor storm and flow being contained within the public right-of-way during the major storm. Calculations were done using UD-Inlet 3.00.xls, Mar., 2011 with the default clogging factors.

Figure 8-6. Inlet Capacity Chart Continuous Grade Conditions, Collector (without parking)

Street Section Data: Street Width Flowline to Flowline = 32'
 Type of Curb and Gutter: D-10-R = 8" vertical
 Type 16 = 6" vertical

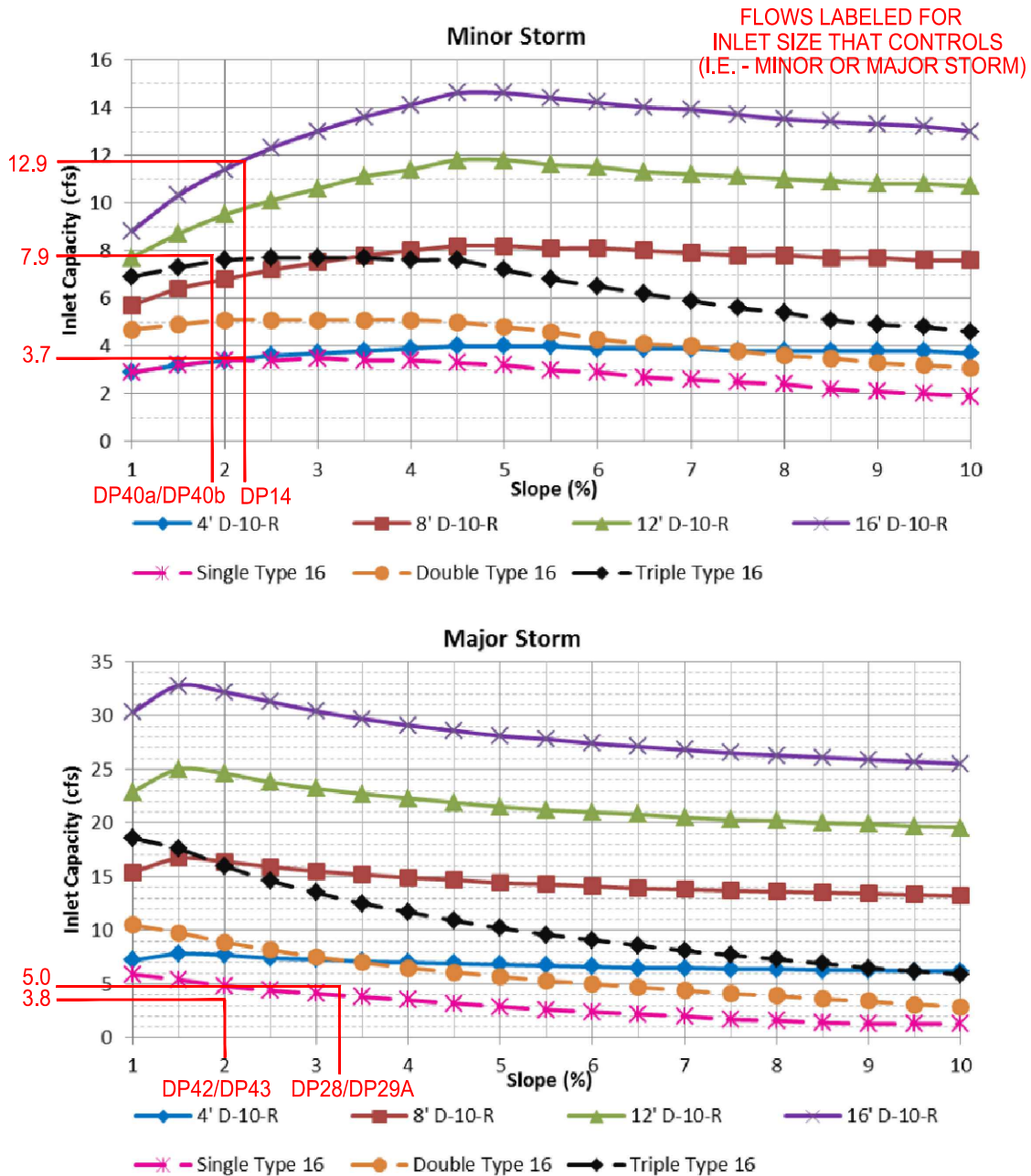

The standard street section parameters as defined in Chapter 7 must apply to use these charts. For non-standard sections, the inlet capacity shall be calculated using the UDFCD spreadsheets. The maximum spread width is limited by the curb height based on no curb overtopping during a minor storm and flow being contained within the public right-of-way during the major storm. Calculations were done using UD-Inlet 3.00.xls, Mar., 2011 with the default clogging factors.

Culvert Report

DP 1 - 36inch

Invert Elev Dn (ft)	= 7343.00
Pipe Length (ft)	= 230.00
Slope (%)	= 7.39
Invert Elev Up (ft)	= 7360.00
Rise (in)	= 36.0
Shape	= Circular
Span (in)	= 36.0
No. Barrels	= 1
n-Value	= 0.013
Culvert Type	= Circular Concrete
Culvert Entrance	= Square edge w/headwall (C)
Coeff. K,M,c,Y,k	= 0.0098, 2, 0.0398, 0.67, 0.5

Embankment	
Top Elevation (ft)	= 7370.00
Top Width (ft)	= 200.00
Crest Width (ft)	= 1000.00

Calculations	
Qmin (cfs)	= 5.70
Qmax (cfs)	= 5.70
Tailwater Elev (ft)	= (dc+D)/2

Highlighted	
Qtotal (cfs)	= 5.70
Qpipe (cfs)	= 5.70
Qovertop (cfs)	= 0.00
Veloc Dn (ft/s)	= 1.23
Veloc Up (ft/s)	= 4.14
HGL Dn (ft)	= 7344.87
HGL Up (ft)	= 7360.75
Hw Elev (ft)	= 7360.91
Hw/D (ft)	= 0.30
Flow Regime	= Inlet Control

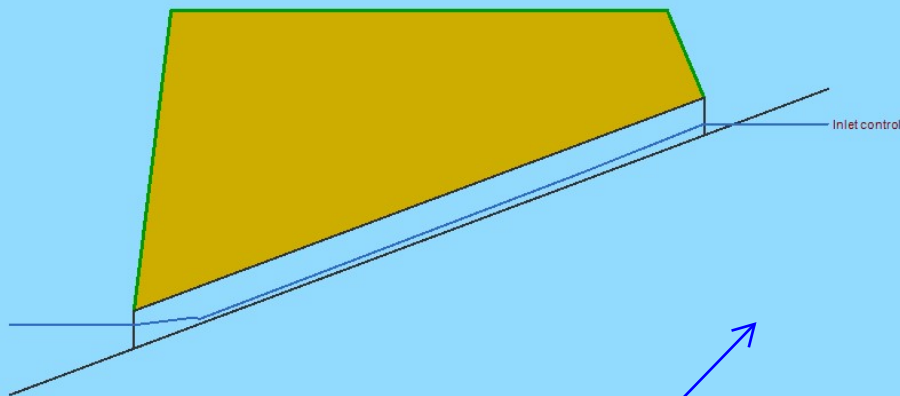

why is this all blue?

Culvert Report

DP 2 - Dual 48inch

Invert Elev Dn (ft)	= 7302.50
Pipe Length (ft)	= 171.00
Slope (%)	= 2.25
Invert Elev Up (ft)	= 7306.34
Rise (in)	= 48.0
Shape	= Circular
Span (in)	= 48.0
No. Barrels	= 2
n-Value	= 0.013
Culvert Type	= Circular Concrete
Culvert Entrance	= Square edge w/headwall (C)
Coeff. K,M,c,Y,k	= 0.0098, 2, 0.0398, 0.67, 0.5

Embankment	
Top Elevation (ft)	= 7314.00
Top Width (ft)	= 55.00
Crest Width (ft)	= 1000.00

Calculations	
Qmin (cfs)	= 57.40
Qmax (cfs)	= 57.40
Tailwater Elev (ft)	= (dc+D)/2

Highlighted	
Qtotal (cfs)	= 57.40
Qpipe (cfs)	= 57.40
Qovertop (cfs)	= 0.00
Veloc Dn (ft/s)	= 3.06
Veloc Up (ft/s)	= 6.18
HGL Dn (ft)	= 7305.29
HGL Up (ft)	= 7307.93
Hw Elev (ft)	= 7308.53
Hw/D (ft)	= 0.55
Flow Regime	= Inlet Control

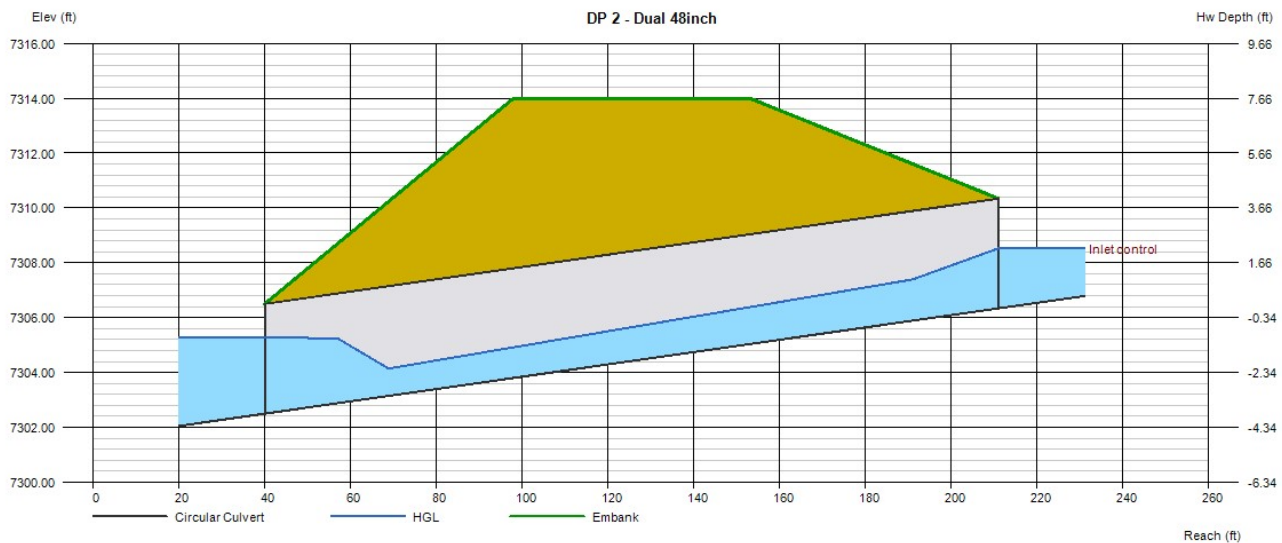

Culvert Report

DP 3 - 48inch

Invert Elev Dn (ft)	= 7288.62
Pipe Length (ft)	= 24.00
Slope (%)	= 5.54
Invert Elev Up (ft)	= 7289.95
Rise (in)	= 48.0
Shape	= Circular
Span (in)	= 48.0
No. Barrels	= 1
n-Value	= 0.013
Culvert Type	= Circular Concrete
Culvert Entrance	= Square edge w/headwall (C)
Coeff. K,M,c,Y,k	= 0.0098, 2, 0.0398, 0.67, 0.5

Embankment	
Top Elevation (ft)	= 7298.00
Top Width (ft)	= 12.00
Crest Width (ft)	= 1000.00

Calculations	
Qmin (cfs)	= 150.00
Qmax (cfs)	= 208.10
Tailwater Elev (ft)	= (dc+D)/2

Highlighted	
Qtotal (cfs)	= 150.00
Qpipe (cfs)	= 147.71
Qovertop (cfs)	= 2.29
Veloc Dn (ft/s)	= 12.00
Veloc Up (ft/s)	= 12.46
HGL Dn (ft)	= 7292.41
HGL Up (ft)	= 7293.53
Hw Elev (ft)	= 7298.02
Hw/D (ft)	= 2.02
Flow Regime	= Inlet Control

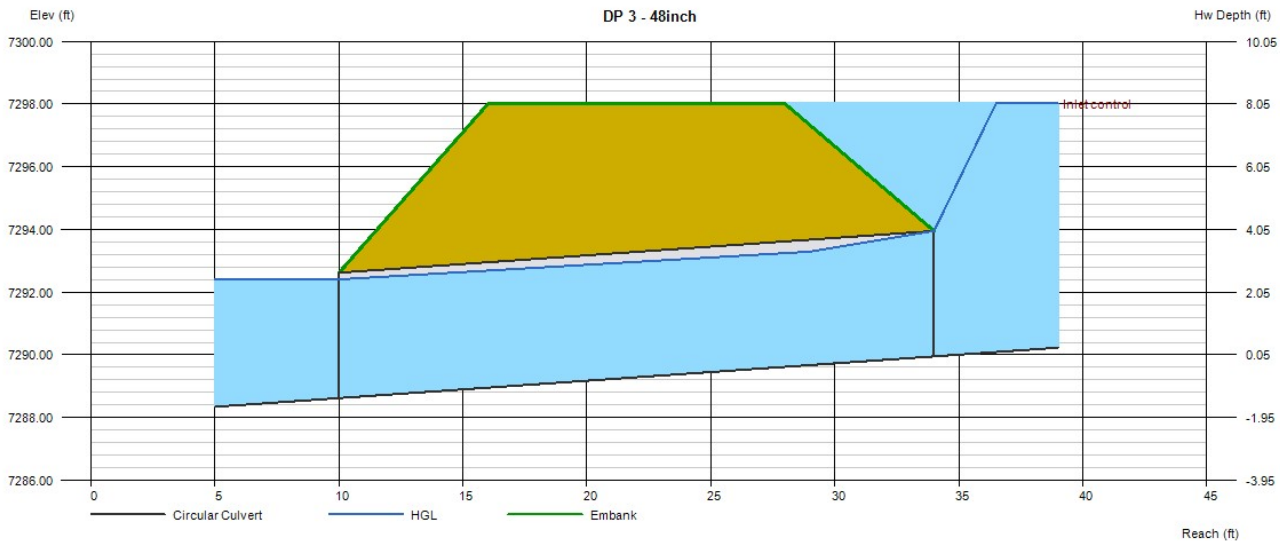

Culvert Report

DP 5 - Dual 48inch

Invert Elev Dn (ft)	= 7284.00
Pipe Length (ft)	= 120.00
Slope (%)	= 2.50
Invert Elev Up (ft)	= 7287.00
Rise (in)	= 48.0
Shape	= Circular
Span (in)	= 48.0
No. Barrels	= 2
n-Value	= 0.023
Culvert Type	= Circular Corrugate Metal Pipe
Culvert Entrance	= Projecting
Coeff. K,M,c,Y,k	= 0.034, 1.5, 0.0553, 0.54, 0.9

Embankment	
Top Elevation (ft)	= 7292.50
Top Width (ft)	= 76.00
Crest Width (ft)	= 1000.00

Calculations	
Qmin (cfs)	= 225.30
Qmax (cfs)	= 225.30
Tailwater Elev (ft)	= (dc+D)/2

Highlighted	
Qtotal (cfs)	= 225.30
Qpipe (cfs)	= 198.23
Qovertop (cfs)	= 27.07
Veloc Dn (ft/s)	= 8.49
Veloc Up (ft/s)	= 9.76
HGL Dn (ft)	= 7287.51
HGL Up (ft)	= 7290.01
Hw Elev (ft)	= 7292.55
Hw/D (ft)	= 1.39
Flow Regime	= Inlet Control

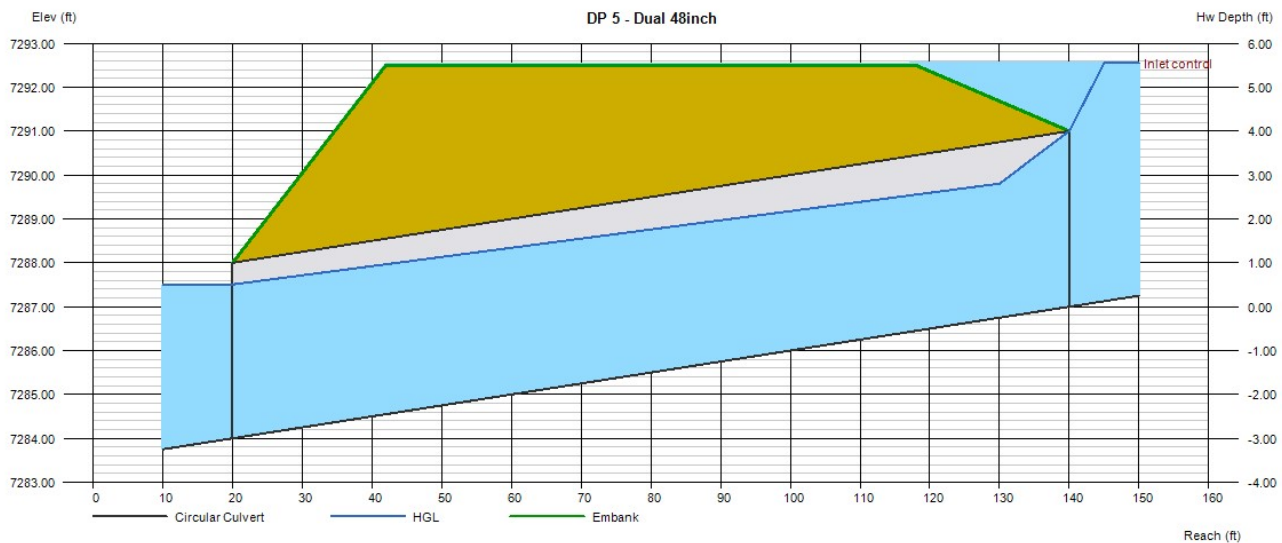

Culvert Report

DP 6 - 48inch

Invert Elev Dn (ft)	= 7251.91
Pipe Length (ft)	= 71.00
Slope (%)	= 5.35
Invert Elev Up (ft)	= 7255.71
Rise (in)	= 48.0
Shape	= Circular
Span (in)	= 48.0
No. Barrels	= 1
n-Value	= 0.023
Culvert Type	= Circular Corrugate Metal Pipe
Culvert Entrance	= Projecting
Coeff. K,M,c,Y,k	= 0.034, 1.5, 0.0553, 0.54, 0.9

Embankment

Top Elevation (ft)	= 7264.00
Top Width (ft)	= 34.00
Crest Width (ft)	= 100.00

Calculations

Qmin (cfs)	= 471.00
Qmax (cfs)	= 471.00
Tailwater Elev (ft)	= (dc+D)/2

Highlighted

Qtotal (cfs)	= 471.00
Qpipe (cfs)	= 144.22
Qovertop (cfs)	= 326.78
Veloc Dn (ft/s)	= 11.74
Veloc Up (ft/s)	= 12.24
HGL Dn (ft)	= 7255.68
HGL Up (ft)	= 7259.26
Hw Elev (ft)	= 7265.05
Hw/D (ft)	= 2.33
Flow Regime	= Inlet Control

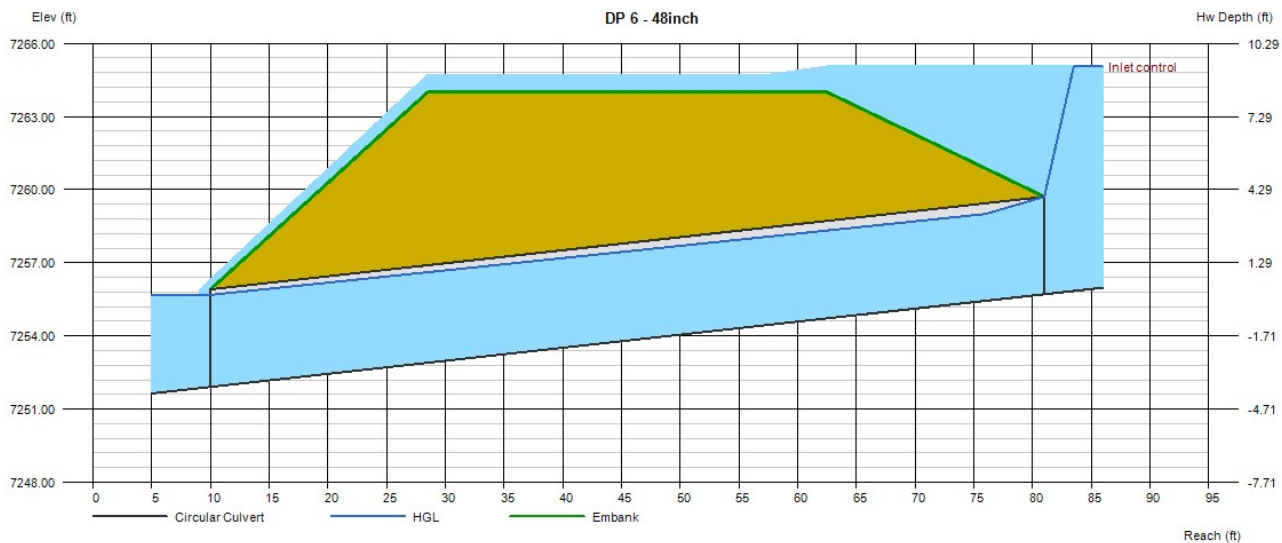

Culvert Report

DP 7 - 48inch

Invert Elev Dn (ft)	= 7303.74
Pipe Length (ft)	= 220.00
Slope (%)	= 2.85
Invert Elev Up (ft)	= 7310.00
Rise (in)	= 48.0
Shape	= Circular
Span (in)	= 48.0
No. Barrels	= 1
n-Value	= 0.023
Culvert Type	= Circular Corrugate Metal Pipe
Culvert Entrance	= Headwall
Coeff. K,M,c,Y,k	= 0.0078, 2, 0.0379, 0.69, 0.5

Embankment

Top Elevation (ft)	= 7316.00
Top Width (ft)	= 190.00
Crest Width (ft)	= 100.00

Calculations

Qmin (cfs)	= 136.70
Qmax (cfs)	= 136.70
Tailwater Elev (ft)	= (dc+D)/2

Highlighted

Qtotal (cfs)	= 136.70
Qpipe (cfs)	= 119.90
Qovertop (cfs)	= 16.80
Veloc Dn (ft/s)	= 9.97
Veloc Up (ft/s)	= 10.83
HGL Dn (ft)	= 7307.39
HGL Up (ft)	= 7313.29
Hw Elev (ft)	= 7316.15
Hw/D (ft)	= 1.54
Flow Regime	= Inlet Control

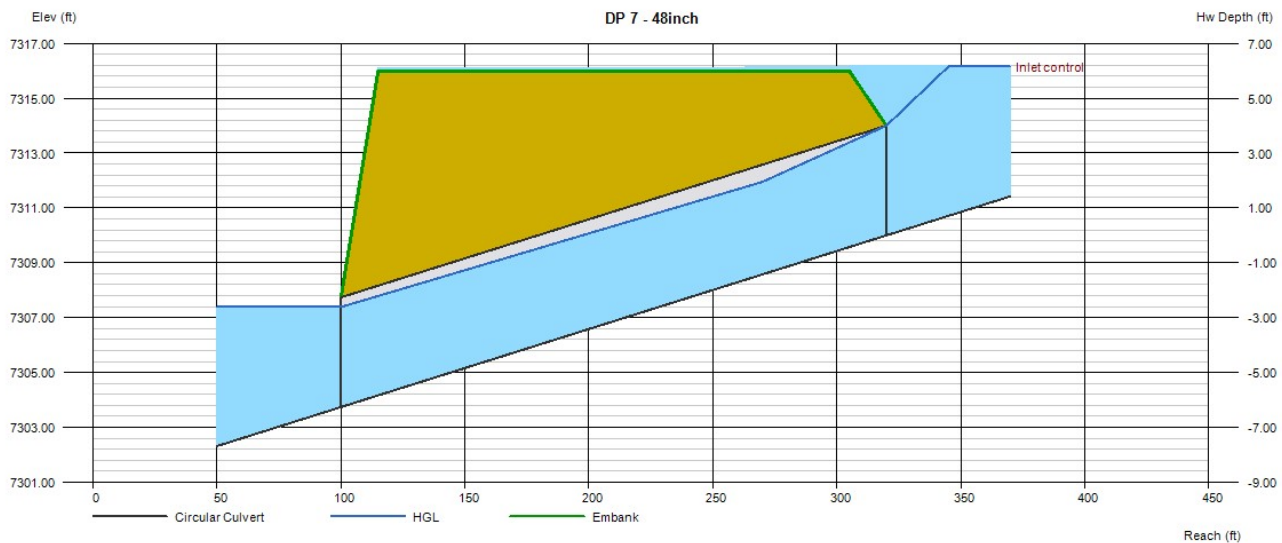

Culvert Report

DP 8 - 48inch

Invert Elev Dn (ft)	= 7274.00
Pipe Length (ft)	= 85.00
Slope (%)	= 2.35
Invert Elev Up (ft)	= 7276.00
Rise (in)	= 48.0
Shape	= Circular
Span (in)	= 48.0
No. Barrels	= 1
n-Value	= 0.013
Culvert Type	= Circular Concrete
Culvert Entrance	= Groove end projecting (C)
Coeff. K,M,c,Y,k	= 0.0045, 2, 0.0317, 0.69, 0.2

Embankment	
Top Elevation (ft)	= 7283.00
Top Width (ft)	= 28.00
Crest Width (ft)	= 100.00

Calculations	
Qmin (cfs)	= 153.20
Qmax (cfs)	= 153.20
Tailwater Elev (ft)	= (dc+D)/2

Highlighted	
Qtotal (cfs)	= 153.20
Qpipe (cfs)	= 147.49
Qovertop (cfs)	= 5.71
Veloc Dn (ft/s)	= 11.98
Veloc Up (ft/s)	= 12.45
HGL Dn (ft)	= 7277.79
HGL Up (ft)	= 7279.57
Hw Elev (ft)	= 7283.08
Hw/D (ft)	= 1.77
Flow Regime	= Inlet Control

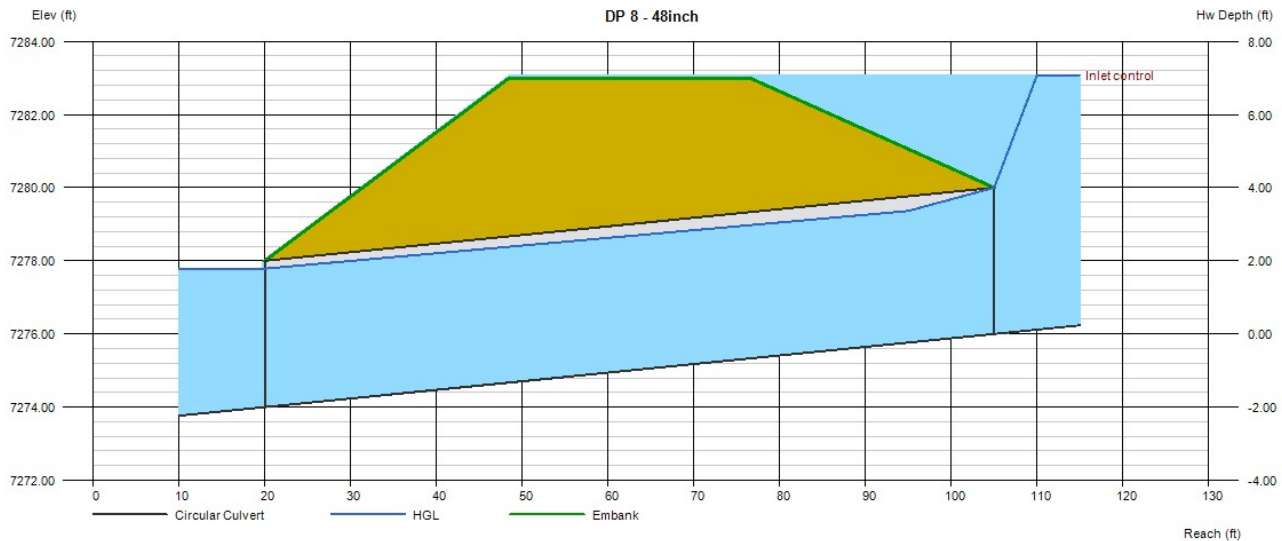

Culvert Report

DP 9 - 48inch

Invert Elev Dn (ft)	= 7270.00
Pipe Length (ft)	= 180.00
Slope (%)	= 2.22
Invert Elev Up (ft)	= 7274.00
Rise (in)	= 48.0
Shape	= Circular
Span (in)	= 48.0
No. Barrels	= 1
n-Value	= 0.013
Culvert Type	= Circular Concrete
Culvert Entrance	= Square edge w/headwall (C)
Coeff. K,M,c,Y,k	= 0.0098, 2, 0.0398, 0.67, 0.5

Embankment	
Top Elevation (ft)	= 7283.00
Top Width (ft)	= 48.00
Crest Width (ft)	= 100.00

Calculations	
Qmin (cfs)	= 167.50
Qmax (cfs)	= 167.50
Tailwater Elev (ft)	= (dc+D)/2

Highlighted	
Qtotal (cfs)	= 167.50
Qpipe (cfs)	= 160.07
Qovertop (cfs)	= 7.43
Veloc Dn (ft/s)	= 12.92
Veloc Up (ft/s)	= 13.27
HGL Dn (ft)	= 7273.83
HGL Up (ft)	= 7277.67
Hw Elev (ft)	= 7283.09
Hw/D (ft)	= 2.27
Flow Regime	= Inlet Control

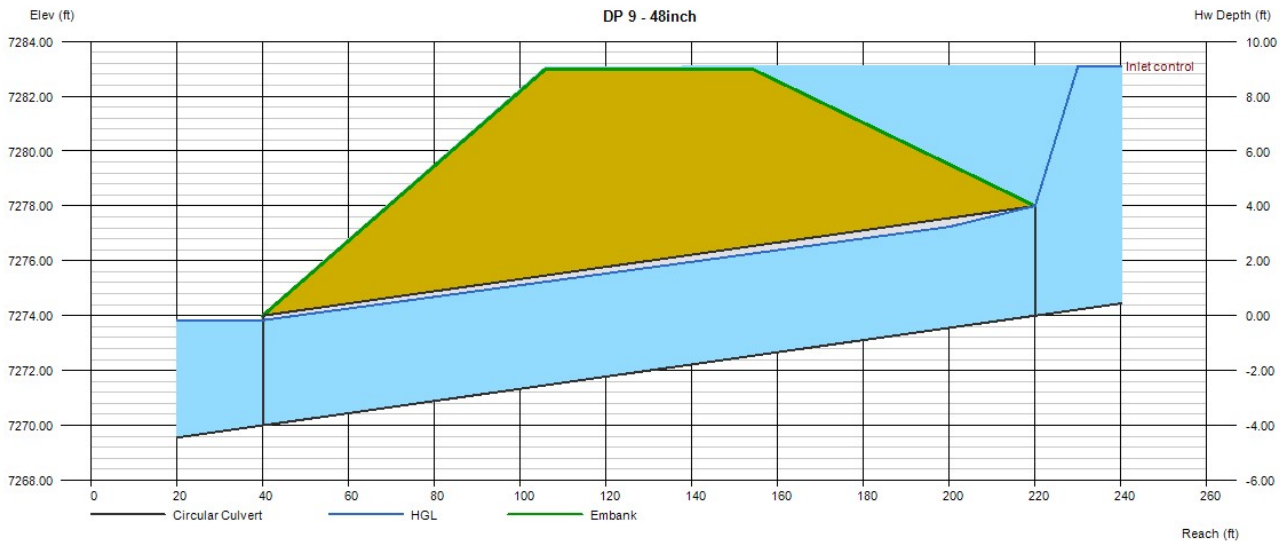

Culvert Report

DP 2 - Dual 48inch

Invert Elev Dn (ft)	= 7302.50
Pipe Length (ft)	= 171.00
Slope (%)	= 2.25
Invert Elev Up (ft)	= 7306.34
Rise (in)	= 48.0
Shape	= Circular
Span (in)	= 48.0
No. Barrels	= 2
n-Value	= 0.013
Culvert Type	= Circular Concrete
Culvert Entrance	= Square edge w/headwall (C)
Coeff. K,M,c,Y,k	= 0.0098, 2, 0.0398, 0.67, 0.5

Embankment	
Top Elevation (ft)	= 7314.00
Top Width (ft)	= 55.00
Crest Width (ft)	= 1000.00

Calculations	
Qmin (cfs)	= 62.20
Qmax (cfs)	= 62.20
Tailwater Elev (ft)	= (dc+D)/2

Highlighted	
Qtotal (cfs)	= 62.20
Qpipe (cfs)	= 62.20
Qovertop (cfs)	= 0.00
Veloc Dn (ft/s)	= 3.28
Veloc Up (ft/s)	= 6.34
HGL Dn (ft)	= 7305.33
HGL Up (ft)	= 7307.99
Hw Elev (ft)	= 7308.63
Hw/D (ft)	= 0.57
Flow Regime	= Inlet Control

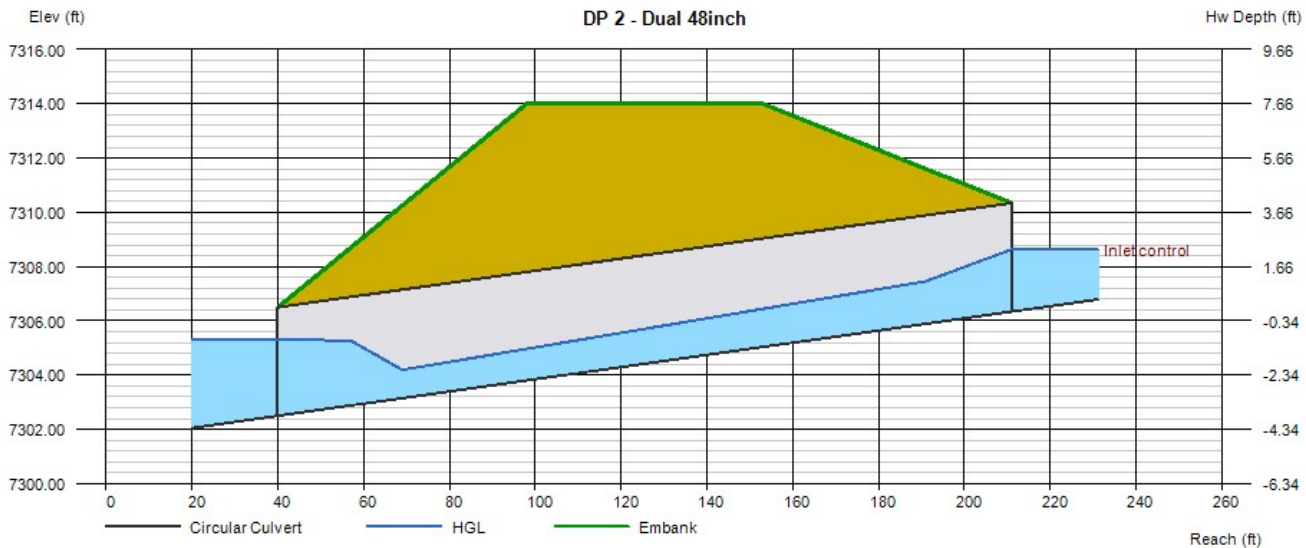

Culvert Report

DP 3 - 48inch

Invert Elev Dn (ft)	= 7288.62
Pipe Length (ft)	= 24.00
Slope (%)	= 5.54
Invert Elev Up (ft)	= 7289.95
Rise (in)	= 48.0
Shape	= Circular
Span (in)	= 48.0
No. Barrels	= 1
n-Value	= 0.013
Culvert Type	= Circular Concrete
Culvert Entrance	= Square edge w/headwall (C)
Coeff. K,M,c,Y,k	= 0.0098, 2, 0.0398, 0.67, 0.5

Embankment	
Top Elevation (ft)	= 7298.00
Top Width (ft)	= 12.00
Crest Width (ft)	= 1000.00

Calculations	
Qmin (cfs)	= 225.60
Qmax (cfs)	= 225.60
Tailwater Elev (ft)	= (dc+D)/2

Highlighted	
Qtotal (cfs)	= 225.60
Qpipe (cfs)	= 148.62
Qovertop (cfs)	= 76.98
Veloc Dn (ft/s)	= 12.07
Veloc Up (ft/s)	= 12.52
HGL Dn (ft)	= 7292.41
HGL Up (ft)	= 7293.53
Hw Elev (ft)	= 7298.09
Hw/D (ft)	= 2.03
Flow Regime	= Inlet Control

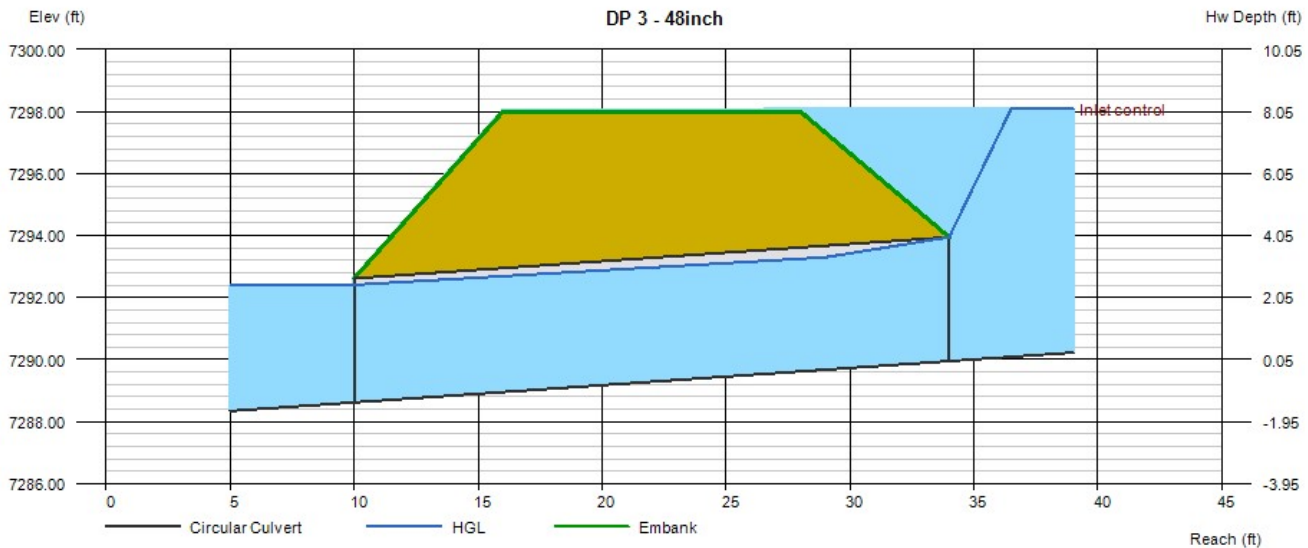

Culvert Crossing: DP6

COUNTY LINE ROAD CROSSING – 48" CMP CULVERT
 INVERT IN 55.7, TOP OF EMBANKMENT 63.0

OVERTOPS ROAD DURING BOTH MINOR AND MAJOR STORM EVENTS

Customized Table

Discharge Names	Total Discharge (cfs)	Culvert Discharge (cfs)	Headwater Elevation (ft)	Inlet Control Depth(ft)	Outlet Control Depth(ft)	Flow Type	Normal Depth (ft)	Critical Depth (ft)	Outlet Depth (ft)	Tailwater Depth (ft)	Outlet Velocity (ft/s)	Tailwater Velocity (ft/s)	Length Full (ft)	Length Free (ft)	Last Step (ft)	Mean Slope (%)	First Depth (ft)	Last Depth (ft)
5 year	214.30	129.74	63.86	8.15	5.37	5-S2n	2.50	3.41	2.57	4.08	15.22	0.00	0.00	70.00	19.11	4.95	0.00	0.00
100 year	488.00	136.92	64.52	8.81	5.95	5-S2n	2.60	3.48	2.67	4.08	15.38	0.00	0.00	70.00	9.72	5.10	0.00	0.00

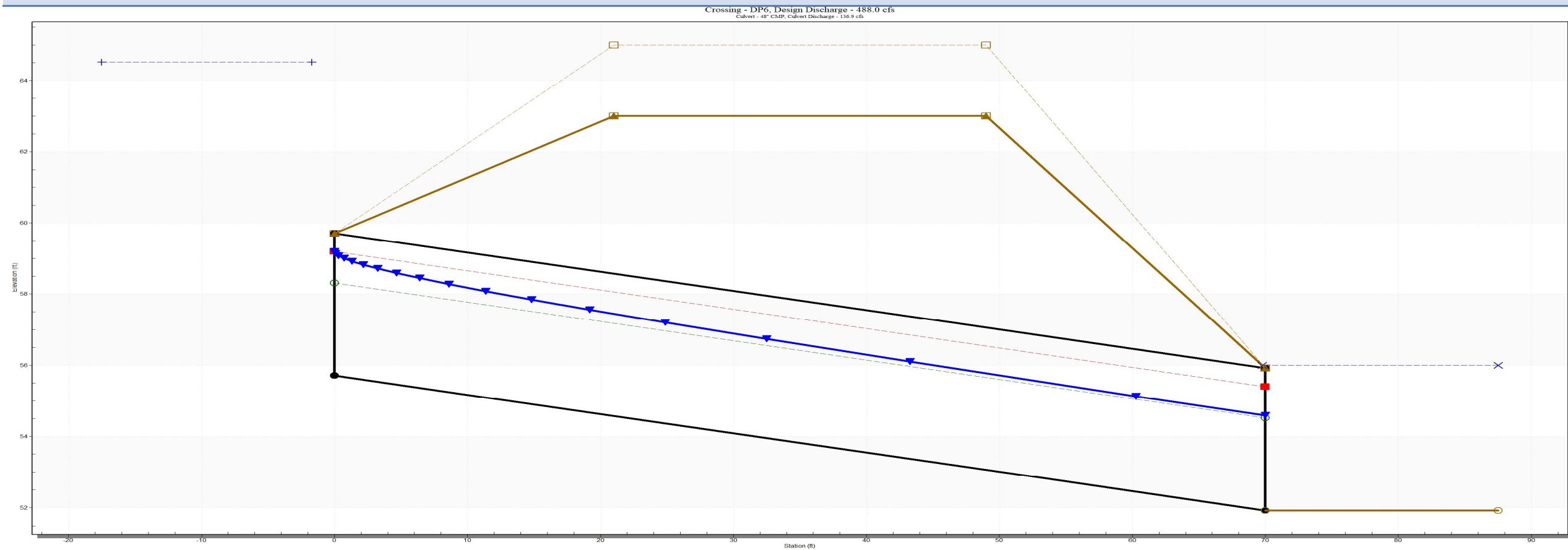

Culvert Report

DP 7 - 48inch

Invert Elev Dn (ft)	= 7303.74
Pipe Length (ft)	= 220.00
Slope (%)	= 2.85
Invert Elev Up (ft)	= 7310.00
Rise (in)	= 48.0
Shape	= Circular
Span (in)	= 48.0
No. Barrels	= 1
n-Value	= 0.023
Culvert Type	= Circular Corrugate Metal Pipe
Culvert Entrance	= Headwall
Coeff. K,M,c,Y,k	= 0.0078, 2, 0.0379, 0.69, 0.5

Embankment

Top Elevation (ft)	= 7316.00
Top Width (ft)	= 190.00
Crest Width (ft)	= 100.00

Calculations

Qmin (cfs)	= 113.30
Qmax (cfs)	= 113.30
Tailwater Elev (ft)	= (dc+D)/2

Highlighted

Qtotal (cfs)	= 113.30
Qpipe (cfs)	= 113.30
Qovertop (cfs)	= 0.00
Veloc Dn (ft/s)	= 9.50
Veloc Up (ft/s)	= 10.48
HGL Dn (ft)	= 7307.35
HGL Up (ft)	= 7313.21
Hw Elev (ft)	= 7315.78
Hw/D (ft)	= 1.45
Flow Regime	= Inlet Control

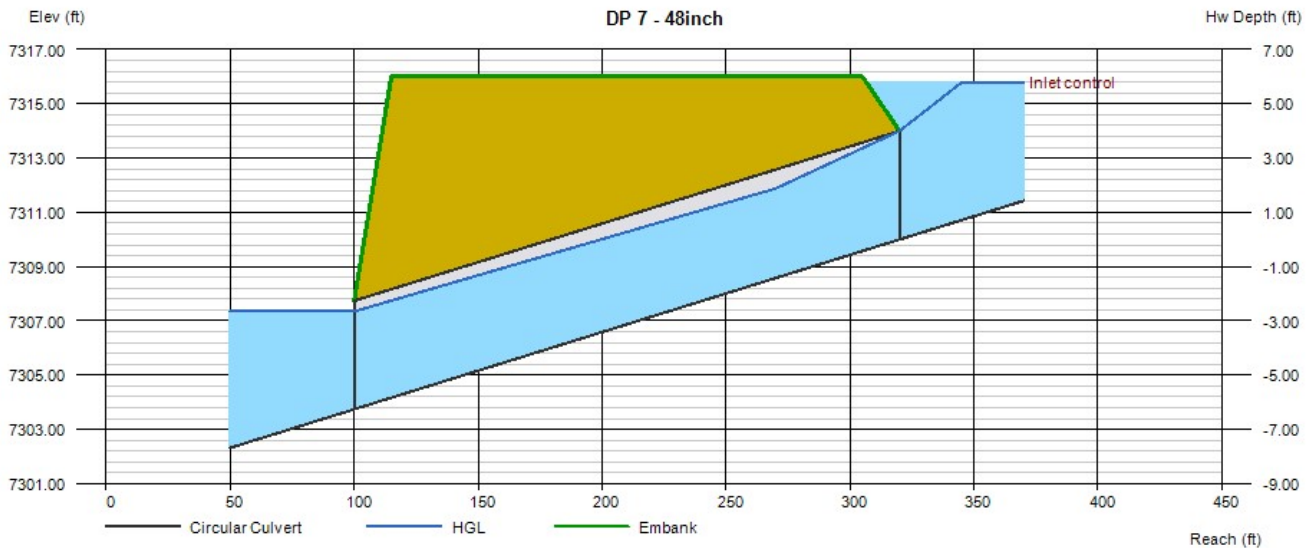

Culvert Report

DP 8 - 48inch

Invert Elev Dn (ft)	= 7274.00
Pipe Length (ft)	= 85.00
Slope (%)	= 2.35
Invert Elev Up (ft)	= 7276.00
Rise (in)	= 48.0
Shape	= Circular
Span (in)	= 48.0
No. Barrels	= 1
n-Value	= 0.013
Culvert Type	= Circular Concrete
Culvert Entrance	= Groove end projecting (C)
Coeff. K,M,c,Y,k	= 0.0045, 2, 0.0317, 0.69, 0.2

Embankment	
Top Elevation (ft)	= 7283.00
Top Width (ft)	= 28.00
Crest Width (ft)	= 100.00

Calculations	
Qmin (cfs)	= 137.40
Qmax (cfs)	= 137.40
Tailwater Elev (ft)	= (dc+D)/2

Highlighted	
Qtotal (cfs)	= 137.40
Qpipe (cfs)	= 137.40
Qovertop (cfs)	= 0.00
Veloc Dn (ft/s)	= 11.24
Veloc Up (ft/s)	= 11.83
HGL Dn (ft)	= 7277.74
HGL Up (ft)	= 7279.48
Hw Elev (ft)	= 7282.50
Hw/D (ft)	= 1.63
Flow Regime	= Inlet Control

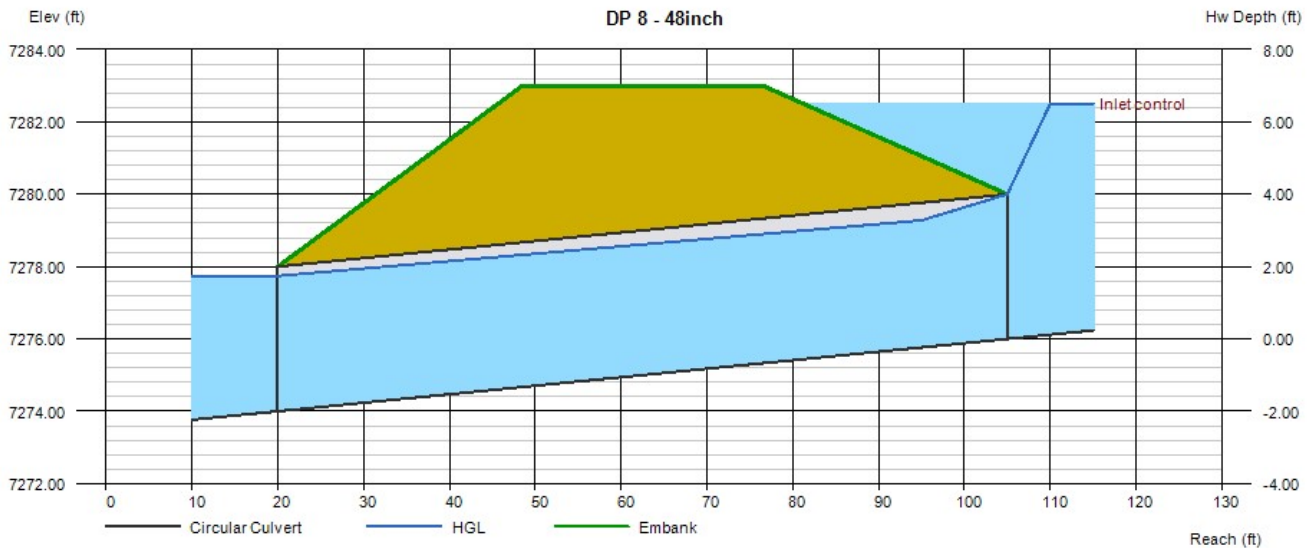

Culvert Report

DP 9 - 48inch

Invert Elev Dn (ft)	= 7270.00
Pipe Length (ft)	= 180.00
Slope (%)	= 2.22
Invert Elev Up (ft)	= 7274.00
Rise (in)	= 48.0
Shape	= Circular
Span (in)	= 48.0
No. Barrels	= 1
n-Value	= 0.013
Culvert Type	= Circular Concrete
Culvert Entrance	= Square edge w/headwall (C)
Coeff. K,M,c,Y,k	= 0.0098, 2, 0.0398, 0.67, 0.5

Embankment	
Top Elevation (ft)	= 7283.00
Top Width (ft)	= 48.00
Crest Width (ft)	= 100.00

Calculations	
Qmin (cfs)	= 151.40
Qmax (cfs)	= 151.40
Tailwater Elev (ft)	= (dc+D)/2

Highlighted	
Qtotal (cfs)	= 151.40
Qpipe (cfs)	= 151.40
Qovertop (cfs)	= 0.00
Veloc Dn (ft/s)	= 12.27
Veloc Up (ft/s)	= 12.70
HGL Dn (ft)	= 7273.80
HGL Up (ft)	= 7277.60
Hw Elev (ft)	= 7282.41
Hw/D (ft)	= 2.10
Flow Regime	= Inlet Control

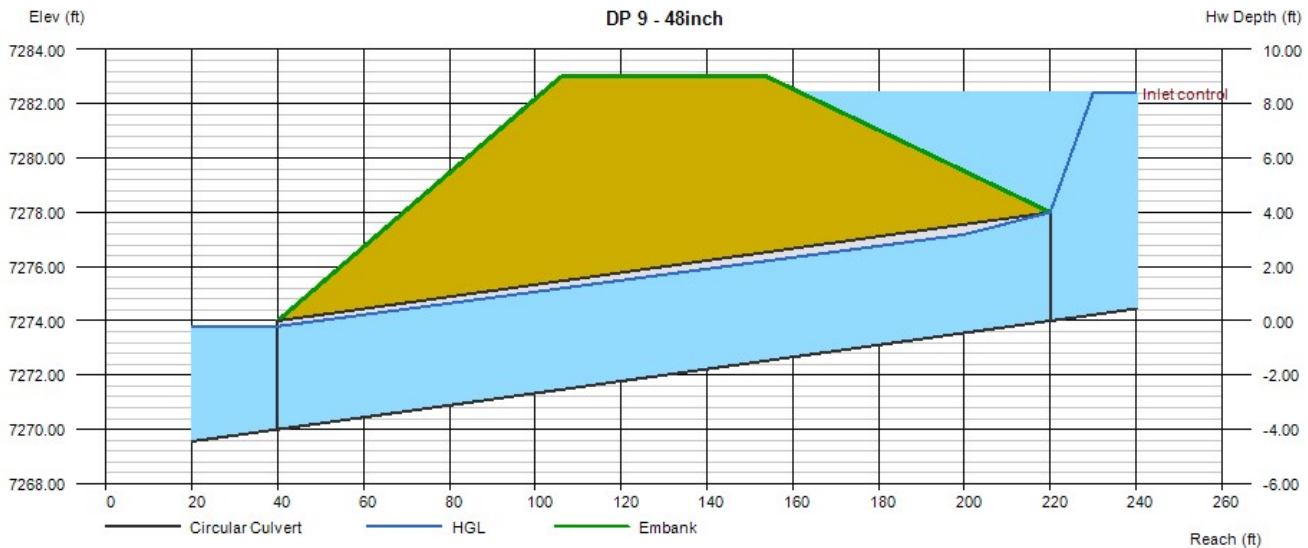

Culvert Crossing: DP54

COUNTY LINE ROAD CROSSING – 48" (3) CULVERTS WITH DEPRESSION AT INLET
 INVERT IN 55.7, TOP OF EMBANKMENT 63.0

Customized Table

Discharge Name	Total Discharge (cfs)	Culvert Discharge (cfs)	Headwater Elevation (ft)	Inlet Control Depth(ft)	Outlet Control Depth(ft)	Flow Type	Normal Depth (ft)	Critical Depth (ft)	Outlet Depth (ft)	Tailwater Depth (ft)	Outlet Velocity (ft/s)	Tailwater Velocity (ft/s)
5 year	211.70	211.70	57.34	4.63	4.25	5-S1t	1.91	2.54	4.00	4.08	5.62	0.00
100 year	431.30	431.30	60.53	7.82	7.82	5-S1t	3.08	3.54	4.00	4.08	11.44	0.00

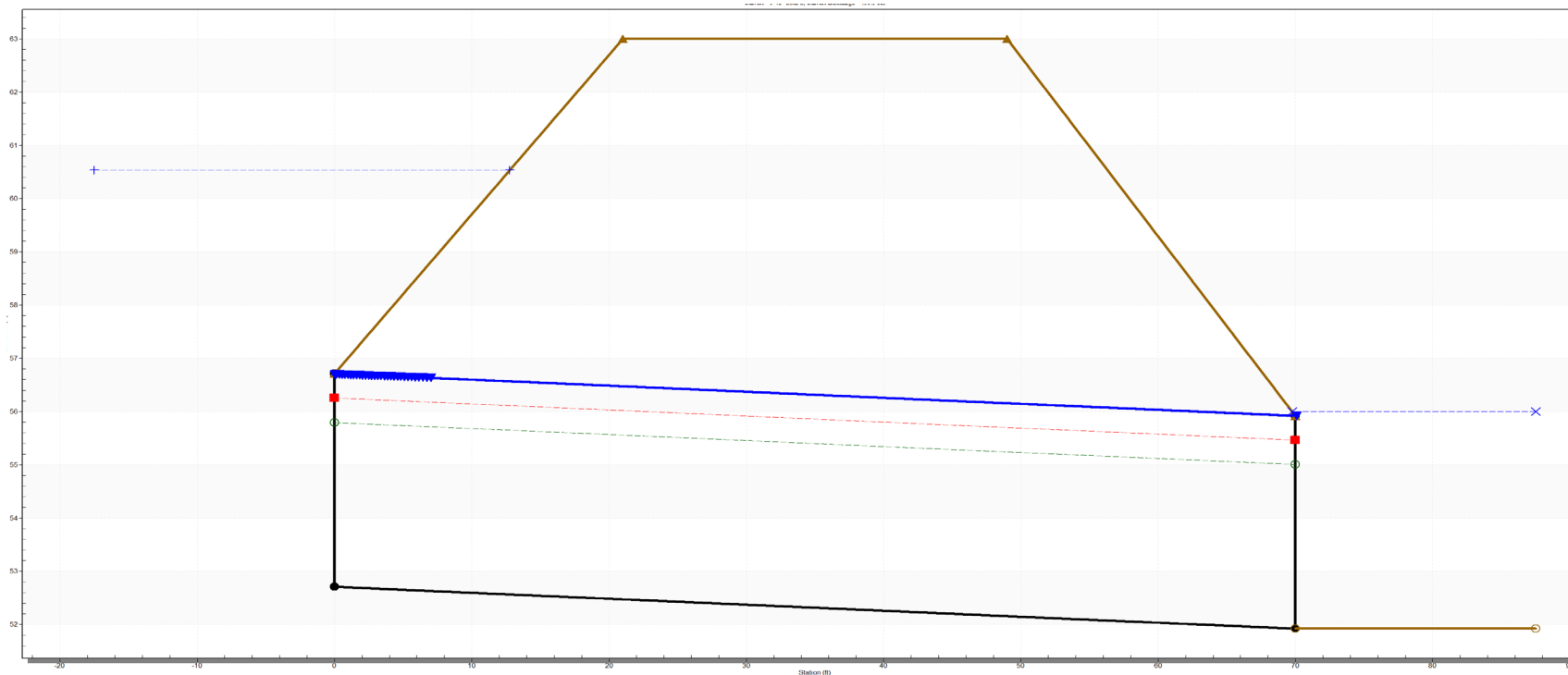

Culvert Report

DP 58 - 48inch

Invert Elev Dn (ft)	= 7274.00
Pipe Length (ft)	= 85.00
Slope (%)	= 2.35
Invert Elev Up (ft)	= 7276.00
Rise (in)	= 48.0
Shape	= Circular
Span (in)	= 48.0
No. Barrels	= 1
n-Value	= 0.013
Culvert Type	= Circular Concrete
Culvert Entrance	= Groove end projecting (C)
Coeff. K,M,c,Y,k	= 0.0045, 2, 0.0317, 0.69, 0.2

Embankment	
Top Elevation (ft)	= 7283.00
Top Width (ft)	= 28.00
Crest Width (ft)	= 100.00

Calculations	
Qmin (cfs)	= 133.30
Qmax (cfs)	= 133.30
Tailwater Elev (ft)	= (dc+D)/2

Highlighted	
Qtotal (cfs)	= 133.30
Qpipe (cfs)	= 133.30
Qovertop (cfs)	= 0.00
Veloc Dn (ft/s)	= 10.94
Veloc Up (ft/s)	= 11.59
HGL Dn (ft)	= 7277.72
HGL Up (ft)	= 7279.44
Hw Elev (ft)	= 7282.28
Hw/D (ft)	= 1.57
Flow Regime	= Inlet Control

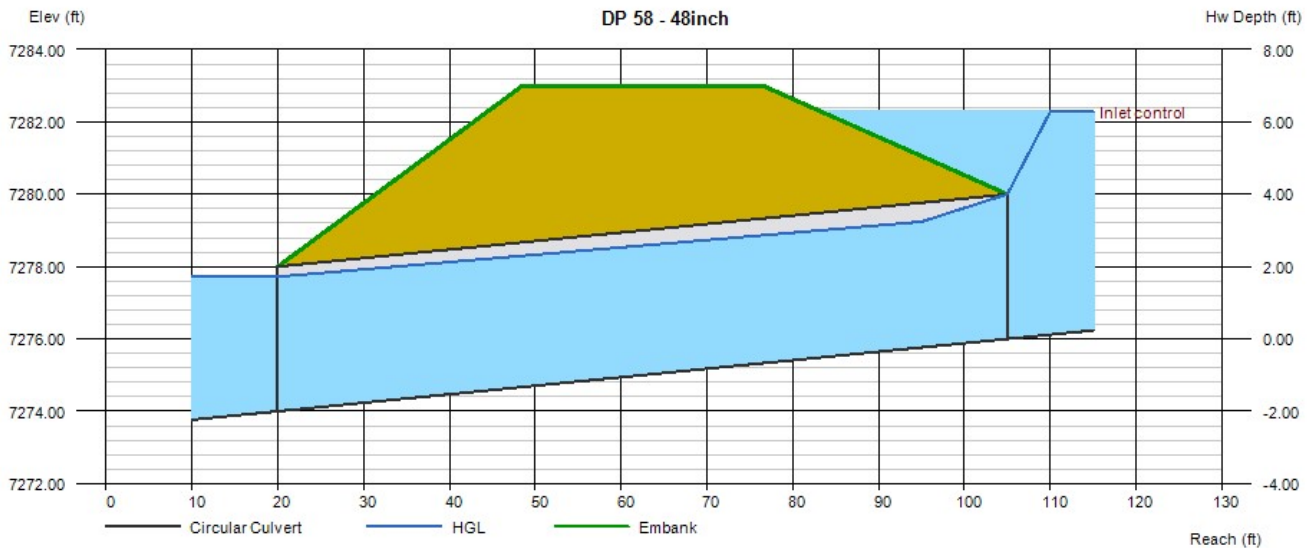

Culvert Report

DP 59 - 48inch

Invert Elev Dn (ft)	= 7270.00
Pipe Length (ft)	= 180.00
Slope (%)	= 2.22
Invert Elev Up (ft)	= 7274.00
Rise (in)	= 48.0
Shape	= Circular
Span (in)	= 48.0
No. Barrels	= 1
n-Value	= 0.013
Culvert Type	= Circular Concrete
Culvert Entrance	= Square edge w/headwall (C)
Coeff. K,M,c,Y,k	= 0.0098, 2, 0.0398, 0.67, 0.5

Embankment	
Top Elevation (ft)	= 7283.00
Top Width (ft)	= 48.00
Crest Width (ft)	= 100.00

Calculations	
Qmin (cfs)	= 147.50
Qmax (cfs)	= 147.50
Tailwater Elev (ft)	= (dc+D)/2

Highlighted	
Qtotal (cfs)	= 147.50
Qpipe (cfs)	= 147.50
Qovertop (cfs)	= 0.00
Veloc Dn (ft/s)	= 11.98
Veloc Up (ft/s)	= 12.45
HGL Dn (ft)	= 7273.79
HGL Up (ft)	= 7277.57
Hw Elev (ft)	= 7282.12
Hw/D (ft)	= 2.03
Flow Regime	= Inlet Control

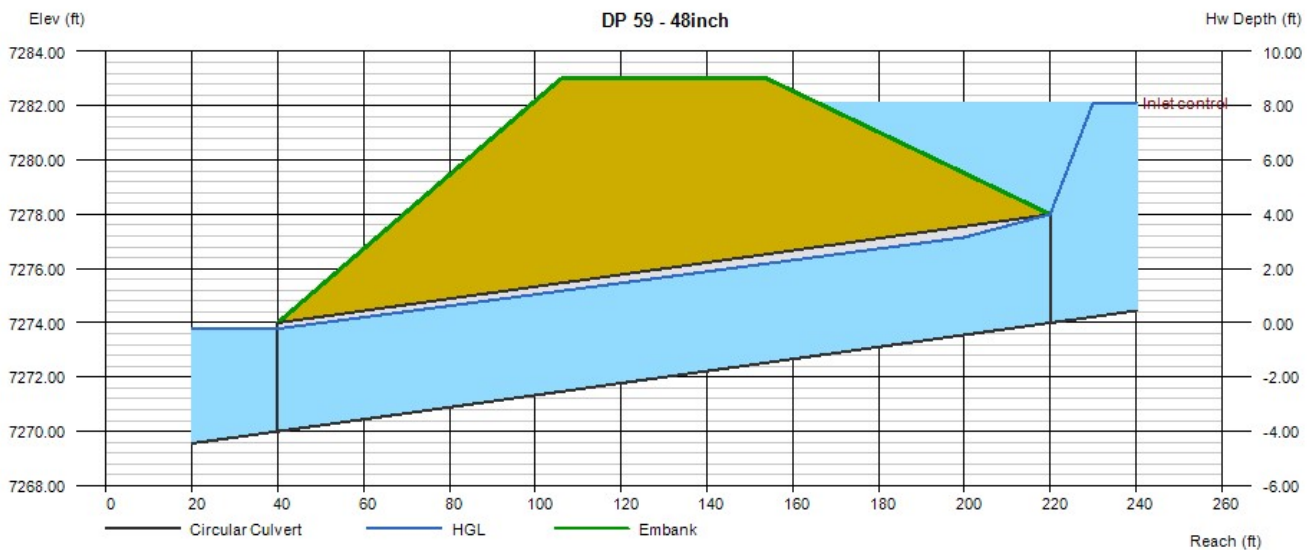

CIRCULAR CONDUIT FLOW (Normal & Critical Depth Computation)

MHFD-Culvert, Version 4.00 (May 2020)

Project: **Monument Ridge East**

Pipe ID: **PIPES 1A THRU 1D**

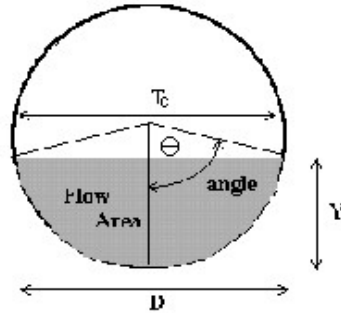

Design Information (Input)	
Pipe Invert Slope	So = 0.0080 ft/ft
Pipe Manning's n-value	n = 0.0130
Pipe Diameter	D = 30.00 inches
Design discharge	Q = 17.20 cfs
Full-Flow Capacity (Calculated)	
Full-flow area	Af = 4.91 sq ft
Full-flow wetted perimeter	Pf = 7.85 ft
Half Central Angle	Theta = 3.14 radians
Full-flow capacity	Qf = 36.79 cfs
Calculation of Normal Flow Condition	
Half Central Angle ($0 < \Theta < 3.14$)	Theta = 1.53 radians
Flow area	An = 2.33 sq ft
Top width	Tn = 2.50 ft
Wetted perimeter	Pn = 3.83 ft
Flow depth	Yn = 1.20 ft
Flow velocity	Vn = 7.37 fps
Discharge	Qn = 17.20 cfs
Percent of Full Flow	Flow = 46.8% of full flow
Normal Depth Froude Number	Fr _n = 1.34 supercritical
Calculation of Critical Flow Condition	
Half Central Angle ($0 < \Theta_c < 3.14$)	Theta-c = 1.69 radians
Critical flow area	Ac = 2.84 sq ft
Critical top width	Tc = 2.48 ft
Critical flow depth	Yc = 1.40 ft
Critical flow velocity	Vc = 6.07 fps
Critical Depth Froude Number	Fr _c = 1.00

CIRCULAR CONDUIT FLOW (Normal & Critical Depth Computation)

MHFD-Culvert, Version 4.00 (May 2020)

Project: **Monument Ridge East**

Pipe ID: **PIPE 1E**

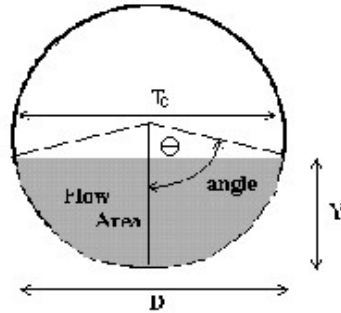

<u>Design Information (Input)</u>	
Pipe Invert Slope	So = 0.0250 ft/ft
Pipe Manning's n-value	n = 0.0130
Pipe Diameter	D = 18.00 inches
Design discharge	Q = 9.60 cfs
<u>Full-Flow Capacity (Calculated)</u>	
Full-flow area	Af = 1.77 sq ft
Full-flow wetted perimeter	Pf = 4.71 ft
Half Central Angle	Theta = 3.14 radians
Full-flow capacity	Qf = 16.65 cfs
<u>Calculation of Normal Flow Condition</u>	
Half Central Angle ($0 < \Theta < 3.14$)	Theta = 1.66 radians
Flow area	An = 0.98 sq ft
Top width	Tn = 1.49 ft
Wetted perimeter	Pn = 2.49 ft
Flow depth	Yn = 0.82 ft
Flow velocity	Vn = 9.76 fps
Discharge	Qn = 9.60 cfs
Percent of Full Flow	Flow = 57.6% of full flow
Normal Depth Froude Number	Fr _n = 2.12 supercritical
<u>Calculation of Critical Flow Condition</u>	
Half Central Angle ($0 < \Theta_c < 3.14$)	Theta-c = 2.21 radians
Critical flow area	Ac = 1.51 sq ft
Critical top width	Tc = 1.21 ft
Critical flow depth	Yc = 1.20 ft
Critical flow velocity	Vc = 6.35 fps
Critical Depth Froude Number	Fr _c = 1.00

CIRCULAR CONDUIT FLOW (Normal & Critical Depth Computation)

MHFD-Culvert, Version 4.00 (May 2020)

Project: **Monument Ridge East**

Pipe ID: **PIPE 2**

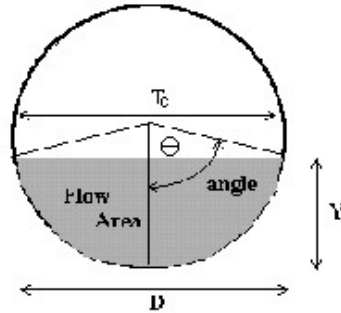

<u>Design Information (Input)</u>	
Pipe Invert Slope	So = 0.0250 ft/ft
Pipe Manning's n-value	n = 0.0130
Pipe Diameter	D = 30.00 inches
Design discharge	Q = 35.40 cfs
<u>Full-Flow Capacity (Calculated)</u>	
Full-flow area	Af = 4.91 sq ft
Full-flow wetted perimeter	Pf = 7.85 ft
Half Central Angle	Theta = 3.14 radians
Full-flow capacity	Qf = 65.03 cfs
<u>Calculation of Normal Flow Condition</u>	
Half Central Angle ($0 < \Theta < 3.14$)	Theta = 1.62 radians
Flow area	An = 2.62 sq ft
Top width	Tn = 2.50 ft
Wetted perimeter	Pn = 4.06 ft
Flow depth	Yn = 1.31 ft
Flow velocity	Vn = 13.53 fps
Discharge	Qn = 35.40 cfs
Percent of Full Flow	Flow = 54.4% of full flow
Normal Depth Froude Number	Fr _n = 2.33 supercritical
<u>Calculation of Critical Flow Condition</u>	
Half Central Angle ($0 < \Theta_c < 3.14$)	Theta-c = 2.23 radians
Critical flow area	Ac = 4.25 sq ft
Critical top width	Tc = 1.97 ft
Critical flow depth	Yc = 2.02 ft
Critical flow velocity	Vc = 8.33 fps
Critical Depth Froude Number	Fr _c = 1.00

CIRCULAR CONDUIT FLOW (Normal & Critical Depth Computation)

MHFD-Culvert, Version 4.00 (May 2020)

Project: **Monument Ridge East**

Pipe ID: **PIPE 3**

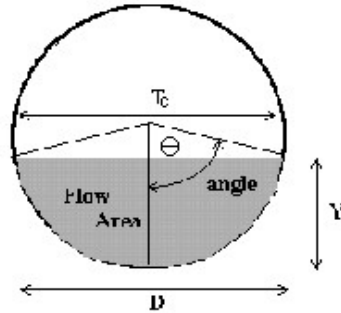

<u>Design Information (Input)</u>	
Pipe Invert Slope	So = 0.0250 ft/ft
Pipe Manning's n-value	n = 0.0130
Pipe Diameter	D = 24.00 inches
Design discharge	Q = 15.00 cfs
<u>Full-Flow Capacity (Calculated)</u>	
Full-flow area	Af = 3.14 sq ft
Full-flow wetted perimeter	Pf = 6.28 ft
Half Central Angle	Theta = 3.14 radians
Full-flow capacity	Qf = 35.87 cfs
<u>Calculation of Normal Flow Condition</u>	
Half Central Angle ($0 < \Theta < 3.14$)	Theta = 1.47 radians
Flow area	An = 1.38 sq ft
Top width	Tn = 1.99 ft
Wetted perimeter	Pn = 2.95 ft
Flow depth	Yn = 0.90 ft
Flow velocity	Vn = 10.91 fps
Discharge	Qn = 15.00 cfs
Percent of Full Flow	Flow = 41.8% of full flow
Normal Depth Froude Number	Fr _n = 2.31 supercritical
<u>Calculation of Critical Flow Condition</u>	
Half Central Angle ($0 < \Theta_c < 3.14$)	Theta-c = 1.98 radians
Critical flow area	Ac = 2.34 sq ft
Critical top width	Tc = 1.84 ft
Critical flow depth	Yc = 1.40 ft
Critical flow velocity	Vc = 6.41 fps
Critical Depth Froude Number	Fr _c = 1.00

CIRCULAR CONDUIT FLOW (Normal & Critical Depth Computation)

MHFD-Culvert, Version 4.00 (May 2020)

Project: **Monument Ridge East**

Pipe ID: **PIPE 4**

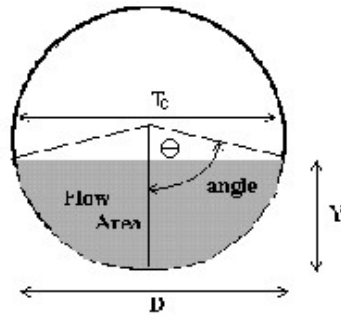

<u>Design Information (Input)</u>	
Pipe Invert Slope	So = 0.0250 ft/ft
Pipe Manning's n-value	n = 0.0130
Pipe Diameter	D = 36.00 inches
Design discharge	Q = 50.40 cfs
<u>Full-Flow Capacity (Calculated)</u>	
Full-flow area	Af = 7.07 sq ft
Full-flow wetted perimeter	Pf = 9.42 ft
Half Central Angle	Theta = 3.14 radians
Full-flow capacity	Qf = 105.74 cfs
<u>Calculation of Normal Flow Condition</u>	
Half Central Angle ($0 < \Theta < 3.14$)	Theta = 1.54 radians
Flow area	An = 3.41 sq ft
Top width	Tn = 3.00 ft
Wetted perimeter	Pn = 4.63 ft
Flow depth	Yn = 1.46 ft
Flow velocity	Vn = 14.78 fps
Discharge	Qn = 50.40 cfs
Percent of Full Flow	Flow = 47.7% of full flow
Normal Depth Froude Number	Fr _n = 2.44 supercritical
<u>Calculation of Critical Flow Condition</u>	
Half Central Angle ($0 < \Theta_c < 3.14$)	Theta-c = 2.14 radians
Critical flow area	Ac = 5.84 sq ft
Critical top width	Tc = 2.53 ft
Critical flow depth	Yc = 2.31 ft
Critical flow velocity	Vc = 8.63 fps
Critical Depth Froude Number	Fr _c = 1.00

CIRCULAR CONDUIT FLOW (Normal & Critical Depth Computation)

MHFD-Culvert, Version 4.00 (May 2020)

Project: **Monument Ridge East**

Pipe ID: **PIPE 5 and 6**

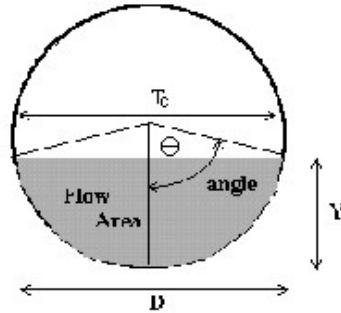

Design Information (Input)	
Pipe Invert Slope	So = 0.0200 ft/ft
Pipe Manning's n-value	n = 0.0130
Pipe Diameter	D = 18.00 inches
Design discharge	Q = 9.70 cfs
Full-Flow Capacity (Calculated)	
Full-flow area	Af = 1.77 sq ft
Full-flow wetted perimeter	Pf = 4.71 ft
Half Central Angle	Theta = 3.14 radians
Full-flow capacity	Qf = 14.90 cfs
Calculation of Normal Flow Condition	
Half Central Angle ($0 < \Theta < 3.14$)	Theta = 1.75 radians
Flow area	An = 1.08 sq ft
Top width	Tn = 1.48 ft
Wetted perimeter	Pn = 2.62 ft
Flow depth	Yn = 0.88 ft
Flow velocity	Vn = 8.98 fps
Discharge	Qn = 9.70 cfs
Percent of Full Flow	Flow = 65.1% of full flow
Normal Depth Froude Number	Fr _n = 1.85 supercritical
Calculation of Critical Flow Condition	
Half Central Angle ($0 < \Theta_c < 3.14$)	Theta-c = 2.22 radians
Critical flow area	Ac = 1.52 sq ft
Critical top width	Tc = 1.20 ft
Critical flow depth	Yc = 1.20 ft
Critical flow velocity	Vc = 6.39 fps
Critical Depth Froude Number	Fr _c = 1.00

CIRCULAR CONDUIT FLOW (Normal & Critical Depth Computation)

MHFD-Culvert, Version 4.00 (May 2020)

Project: **Monument Ridge East**

Pipe ID: **PIPE 7**

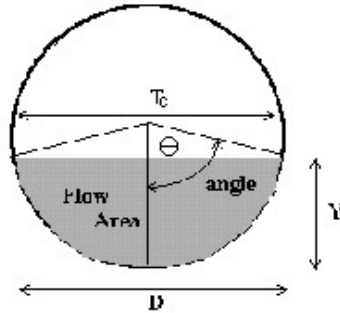

Design Information (Input)	
Pipe Invert Slope	So = 0.1000 ft/ft
Pipe Manning's n-value	n = 0.0130
Pipe Diameter	D = 36.00 inches
Design discharge	Q = 60.00 cfs
Full-Flow Capacity (Calculated)	
Full-flow area	Af = 7.07 sq ft
Full-flow wetted perimeter	Pf = 9.42 ft
Half Central Angle	Theta = 3.14 radians
Full-flow capacity	Qf = 211.49 cfs
Calculation of Normal Flow Condition	
Half Central Angle ($0 < \Theta < 3.14$)	Theta = 1.30 radians
Flow area	An = 2.33 sq ft
Top width	Tn = 2.89 ft
Wetted perimeter	Pn = 3.89 ft
Flow depth	Yn = 1.09 ft
Flow velocity	Vn = 25.76 fps
Discharge	Qn = 60.00 cfs
Percent of Full Flow	Flow = 28.4% of full flow
Normal Depth Froude Number	Fr _n = 5.05 supercritical
Calculation of Critical Flow Condition	
Half Central Angle ($0 < \Theta_c < 3.14$)	Theta-c = 2.30 radians
Critical flow area	Ac = 6.30 sq ft
Critical top width	Tc = 2.23 ft
Critical flow depth	Yc = 2.50 ft
Critical flow velocity	Vc = 9.53 fps
Critical Depth Froude Number	Fr _c = 1.00

CIRCULAR CONDUIT FLOW (Normal & Critical Depth Computation)

MHFD-Culvert, Version 4.00 (May 2020)

Project: **Monument Ridge East**

Pipe ID: **PIPE 8**

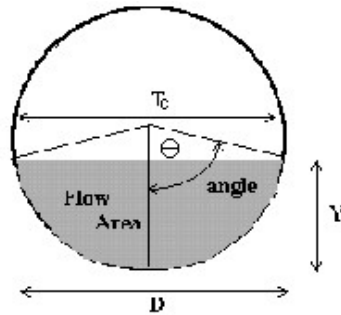

<u>Design Information (Input)</u>	
Pipe Invert Slope	So = 0.1000 ft/ft
Pipe Manning's n-value	n = 0.0130
Pipe Diameter	D = 18.00 inches
Design discharge	Q = 20.70 cfs
<u>Full-Flow Capacity (Calculated)</u>	
Full-flow area	Af = 1.77 sq ft
Full-flow wetted perimeter	Pf = 4.71 ft
Half Central Angle	Theta = 3.14 radians
Full-flow capacity	Qf = 33.31 cfs
<u>Calculation of Normal Flow Condition</u>	
Half Central Angle ($0 < \Theta < 3.14$)	Theta = 1.71 radians
Flow area	An = 1.04 sq ft
Top width	Tn = 1.48 ft
Wetted perimeter	Pn = 2.57 ft
Flow depth	Yn = 0.86 ft
Flow velocity	Vn = 19.86 fps
Discharge	Qn = 20.70 cfs
Percent of Full Flow	Flow = 62.2% of full flow
Normal Depth Froude Number	Fr _n = 4.18 supercritical
<u>Calculation of Critical Flow Condition</u>	
Half Central Angle ($0 < \Theta_c < 3.14$)	Theta-c = 2.87 radians
Critical flow area	Ac = 1.76 sq ft
Critical top width	Tc = 0.41 ft
Critical flow depth	Yc = 1.47 ft
Critical flow velocity	Vc = 11.77 fps
Critical Depth Froude Number	Fr _c = 1.00

CIRCULAR CONDUIT FLOW (Normal & Critical Depth Computation)

MHFD-Culvert, Version 4.00 (May 2020)

Project: **Monument Ridge East**

Pipe ID: **PIPE 11**

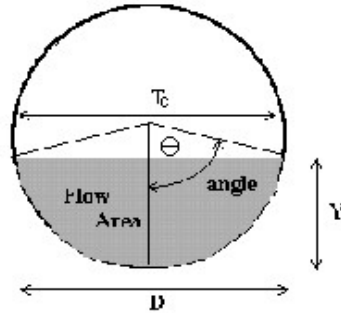

Design Information (Input)	
Pipe Invert Slope	So = 0.0100 ft/ft
Pipe Manning's n-value	n = 0.0130
Pipe Diameter	D = 24.00 inches
Design discharge	Q = 15.30 cfs
Full-Flow Capacity (Calculated)	
Full-flow area	Af = 3.14 sq ft
Full-flow wetted perimeter	Pf = 6.28 ft
Half Central Angle	Theta = 3.14 radians
Full-flow capacity	Qf = 22.68 cfs
Calculation of Normal Flow Condition	
Half Central Angle ($0 < \Theta < 3.14$)	Theta = 1.78 radians
Flow area	An = 1.97 sq ft
Top width	Tn = 1.96 ft
Wetted perimeter	Pn = 3.55 ft
Flow depth	Yn = 1.20 ft
Flow velocity	Vn = 7.75 fps
Discharge	Qn = 15.30 cfs
Percent of Full Flow	Flow = 67.5% of full flow
Normal Depth Froude Number	Fr _n = 1.36 supercritical
Calculation of Critical Flow Condition	
Half Central Angle ($0 < \Theta_c < 3.14$)	Theta-c = 1.99 radians
Critical flow area	Ac = 2.37 sq ft
Critical top width	Tc = 1.82 ft
Critical flow depth	Yc = 1.41 ft
Critical flow velocity	Vc = 6.46 fps
Critical Depth Froude Number	Fr _c = 1.00

CIRCULAR CONDUIT FLOW (Normal & Critical Depth Computation)

MHFD-Culvert, Version 4.00 (May 2020)

Project: **Monument Ridge East**

Pipe ID: **PIPE 12**

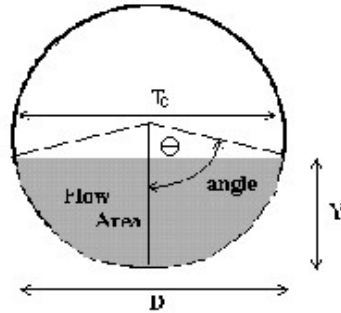

<u>Design Information (Input)</u>	
Pipe Invert Slope	So = 0.0400 ft/ft
Pipe Manning's n-value	n = 0.0130
Pipe Diameter	D = 24.00 inches
Design discharge	Q = 30.60 cfs
<u>Full-Flow Capacity (Calculated)</u>	
Full-flow area	Af = 3.14 sq ft
Full-flow wetted perimeter	Pf = 6.28 ft
Half Central Angle	Theta = 3.14 radians
Full-flow capacity	Qf = 45.37 cfs
<u>Calculation of Normal Flow Condition</u>	
Half Central Angle ($0 < \Theta < 3.14$)	Theta = 1.78 radians
Flow area	An = 1.97 sq ft
Top width	Tn = 1.96 ft
Wetted perimeter	Pn = 3.55 ft
Flow depth	Yn = 1.20 ft
Flow velocity	Vn = 15.50 fps
Discharge	Qn = 30.60 cfs
Percent of Full Flow	Flow = 67.5% of full flow
Normal Depth Froude Number	Fr _n = 2.72 supercritical
<u>Calculation of Critical Flow Condition</u>	
Half Central Angle ($0 < \Theta_c < 3.14$)	Theta-c = 2.63 radians
Critical flow area	Ac = 3.06 sq ft
Critical top width	Tc = 0.98 ft
Critical flow depth	Yc = 1.87 ft
Critical flow velocity	Vc = 10.01 fps
Critical Depth Froude Number	Fr _c = 1.00

CIRCULAR CONDUIT FLOW (Normal & Critical Depth Computation)

MHFD-Culvert, Version 4.00 (May 2020)

Project: **Monument Ridge East**

Pipe ID: **PIPE 13A**

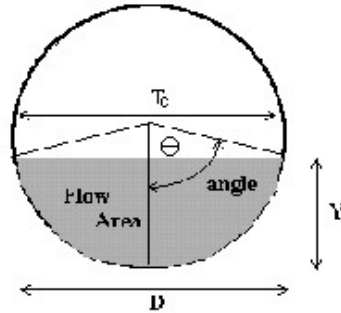

<u>Design Information (Input)</u>	
Pipe Invert Slope	So = 0.0100 ft/ft
Pipe Manning's n-value	n = 0.0130
Pipe Diameter	D = 24.00 inches
Design discharge	Q = 12.30 cfs
<u>Full-Flow Capacity (Calculated)</u>	
Full-flow area	Af = 3.14 sq ft
Full-flow wetted perimeter	Pf = 6.28 ft
Half Central Angle	Theta = 3.14 radians
Full-flow capacity	Qf = 22.68 cfs
<u>Calculation of Normal Flow Condition</u>	
Half Central Angle ($0 < \Theta < 3.14$)	Theta = 1.62 radians
Flow area	An = 1.67 sq ft
Top width	Tn = 2.00 ft
Wetted perimeter	Pn = 3.24 ft
Flow depth	Yn = 1.05 ft
Flow velocity	Vn = 7.37 fps
Discharge	Qn = 12.30 cfs
Percent of Full Flow	Flow = 54.2% of full flow
Normal Depth Froude Number	Fr _n = 1.42 supercritical
<u>Calculation of Critical Flow Condition</u>	
Half Central Angle ($0 < \Theta_c < 3.14$)	Theta-c = 1.83 radians
Critical flow area	Ac = 2.09 sq ft
Critical top width	Tc = 1.93 ft
Critical flow depth	Yc = 1.26 ft
Critical flow velocity	Vc = 5.90 fps
Critical Depth Froude Number	Fr _c = 1.00

CIRCULAR CONDUIT FLOW (Normal & Critical Depth Computation)

MHFD-Culvert, Version 4.00 (May 2020)

Project: Monument Ridge East
Pipe ID: PIPE 13B

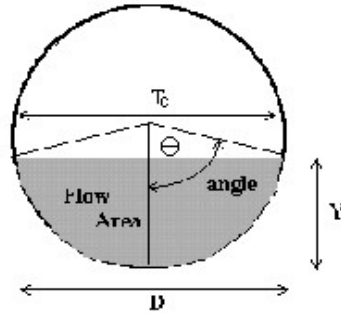

<u>Design Information (Input)</u>			
Pipe Invert Slope	So = <table border="1" style="display: inline-table; border-collapse: collapse;"><tr><td style="width: 50px; text-align: center;">0.0100</td><td style="width: 50px; text-align: right;">ft/ft</td></tr></table>	0.0100	ft/ft
0.0100	ft/ft		
Pipe Manning's n-value	n = <table border="1" style="display: inline-table; border-collapse: collapse;"><tr><td style="width: 50px; text-align: center;">0.0130</td><td></td></tr></table>	0.0130	
0.0130			
Pipe Diameter	D = <table border="1" style="display: inline-table; border-collapse: collapse;"><tr><td style="width: 50px; text-align: center;">30.00</td><td style="width: 50px; text-align: right;">inches</td></tr></table>	30.00	inches
30.00	inches		
Design discharge	Q = <table border="1" style="display: inline-table; border-collapse: collapse;"><tr><td style="width: 50px; text-align: center;">24.70</td><td style="width: 50px; text-align: right;">cfs</td></tr></table>	24.70	cfs
24.70	cfs		
<u>Full-Flow Capacity (Calculated)</u>			
Full-flow area	Af = <table border="1" style="display: inline-table; border-collapse: collapse;"><tr><td style="width: 50px; text-align: center;">4.91</td><td style="width: 50px; text-align: right;">sq ft</td></tr></table>	4.91	sq ft
4.91	sq ft		
Full-flow wetted perimeter	Pf = <table border="1" style="display: inline-table; border-collapse: collapse;"><tr><td style="width: 50px; text-align: center;">7.85</td><td style="width: 50px; text-align: right;">ft</td></tr></table>	7.85	ft
7.85	ft		
Half Central Angle	Theta = <table border="1" style="display: inline-table; border-collapse: collapse;"><tr><td style="width: 50px; text-align: center;">3.14</td><td style="width: 50px; text-align: right;">radians</td></tr></table>	3.14	radians
3.14	radians		
Full-flow capacity	Qf = <table border="1" style="display: inline-table; border-collapse: collapse;"><tr><td style="width: 50px; text-align: center;">41.13</td><td style="width: 50px; text-align: right;">cfs</td></tr></table>	41.13	cfs
41.13	cfs		
<u>Calculation of Normal Flow Condition</u>			
Half Central Angle ($0 < \theta < 3.14$)	Theta = <table border="1" style="display: inline-table; border-collapse: collapse;"><tr><td style="width: 50px; text-align: center;">1.69</td><td style="width: 50px; text-align: right;">radians</td></tr></table>	1.69	radians
1.69	radians		
Flow area	An = <table border="1" style="display: inline-table; border-collapse: collapse;"><tr><td style="width: 50px; text-align: center;">2.82</td><td style="width: 50px; text-align: right;">sq ft</td></tr></table>	2.82	sq ft
2.82	sq ft		
Top width	Tn = <table border="1" style="display: inline-table; border-collapse: collapse;"><tr><td style="width: 50px; text-align: center;">2.48</td><td style="width: 50px; text-align: right;">ft</td></tr></table>	2.48	ft
2.48	ft		
Wetted perimeter	Pn = <table border="1" style="display: inline-table; border-collapse: collapse;"><tr><td style="width: 50px; text-align: center;">4.22</td><td style="width: 50px; text-align: right;">ft</td></tr></table>	4.22	ft
4.22	ft		
Flow depth	Yn = <table border="1" style="display: inline-table; border-collapse: collapse;"><tr><td style="width: 50px; text-align: center;">1.40</td><td style="width: 50px; text-align: right;">ft</td></tr></table>	1.40	ft
1.40	ft		
Flow velocity	Vn = <table border="1" style="display: inline-table; border-collapse: collapse;"><tr><td style="width: 50px; text-align: center;">8.76</td><td style="width: 50px; text-align: right;">fps</td></tr></table>	8.76	fps
8.76	fps		
Discharge	Qn = <table border="1" style="display: inline-table; border-collapse: collapse;"><tr><td style="width: 50px; text-align: center;">24.70</td><td style="width: 50px; text-align: right;">cfs</td></tr></table>	24.70	cfs
24.70	cfs		
Percent of Full Flow	Flow = <table border="1" style="display: inline-table; border-collapse: collapse;"><tr><td style="width: 50px; text-align: center;">60.1%</td><td style="width: 50px; text-align: right;">of full flow</td></tr></table>	60.1%	of full flow
60.1%	of full flow		
Normal Depth Froude Number	Fr _n = <table border="1" style="display: inline-table; border-collapse: collapse;"><tr><td style="width: 50px; text-align: center;">1.45</td><td style="width: 50px; text-align: right;">supercritical</td></tr></table>	1.45	supercritical
1.45	supercritical		
<u>Calculation of Critical Flow Condition</u>			
Half Central Angle ($0 < \theta_c < 3.14$)	Theta-c = <table border="1" style="display: inline-table; border-collapse: collapse;"><tr><td style="width: 50px; text-align: center;">1.93</td><td style="width: 50px; text-align: right;">radians</td></tr></table>	1.93	radians
1.93	radians		
Critical flow area	Ac = <table border="1" style="display: inline-table; border-collapse: collapse;"><tr><td style="width: 50px; text-align: center;">3.54</td><td style="width: 50px; text-align: right;">sq ft</td></tr></table>	3.54	sq ft
3.54	sq ft		
Critical top width	Tc = <table border="1" style="display: inline-table; border-collapse: collapse;"><tr><td style="width: 50px; text-align: center;">2.34</td><td style="width: 50px; text-align: right;">ft</td></tr></table>	2.34	ft
2.34	ft		
Critical flow depth	Yc = <table border="1" style="display: inline-table; border-collapse: collapse;"><tr><td style="width: 50px; text-align: center;">1.69</td><td style="width: 50px; text-align: right;">ft</td></tr></table>	1.69	ft
1.69	ft		
Critical flow velocity	Vc = <table border="1" style="display: inline-table; border-collapse: collapse;"><tr><td style="width: 50px; text-align: center;">6.98</td><td style="width: 50px; text-align: right;">fps</td></tr></table>	6.98	fps
6.98	fps		
Critical Depth Froude Number	Fr _c = <table border="1" style="display: inline-table; border-collapse: collapse;"><tr><td style="width: 50px; text-align: center;">1.00</td><td></td></tr></table>	1.00	
1.00			

CIRCULAR CONDUIT FLOW (Normal & Critical Depth Computation)

MHFD-Culvert, Version 4.00 (May 2020)

Project: Monument Ridge East

Pipe ID: PIPE 15

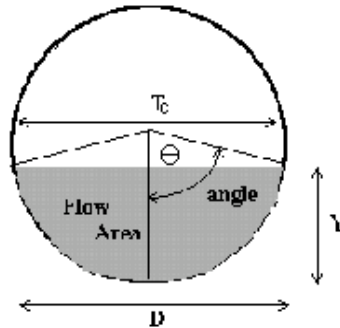

Design Information (Input)	
Pipe Invert Slope	So = 0.0200 ft/ft
Pipe Manning's n-value	n = 0.0130
Pipe Diameter	D = 24.00 inches
Design discharge	Q = 19.60 cfs
Full-Flow Capacity (Calculated)	
Full-flow area	Af = 3.14 sq ft
Full-flow wetted perimeter	Pf = 6.28 ft
Half Central Angle	Theta = 3.14 radians
Full-flow capacity	Qf = 32.08 cfs
Calculation of Normal Flow Condition	
Half Central Angle ($0 < \text{Theta} < 3.14$)	Theta = 1.70 radians
Flow area	An = 1.83 sq ft
Top width	Tn = 1.98 ft
Wetted perimeter	Pn = 3.40 ft
Flow depth	Yn = 1.13 ft
Flow velocity	Vn = 10.72 fps
Discharge	Qn = 19.60 cfs
Percent of Full Flow	Flow = 61.1% of full flow
Normal Depth Froude Number	Fr _n = 1.97 supercritical
Calculation of Critical Flow Condition	
Half Central Angle ($0 < \text{Theta-c} < 3.14$)	Theta-c = 2.20 radians
Critical flow area	Ac = 2.68 sq ft
Critical top width	Tc = 1.61 ft
Critical flow depth	Yc = 1.59 ft
Critical flow velocity	Vc = 7.31 fps
Critical Depth Froude Number	Fr _c = 1.00

CIRCULAR CONDUIT FLOW (Normal & Critical Depth Computation)

MHFD-Culvert, Version 4.00 (May 2020)

Project: Monument Ridge East

Pipe ID: PIPE 16

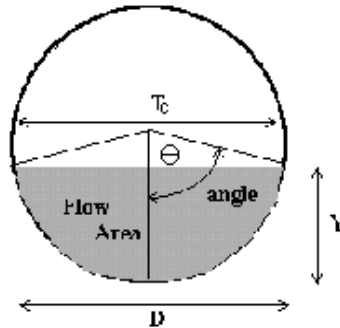

Design Information (Input)	
Pipe Invert Slope	So = 0.0100 ft/ft
Pipe Manning's n-value	n = 0.0130
Pipe Diameter	D = 24.00 inches
Design discharge	Q = 12.20 cfs
Full-Flow Capacity (Calculated)	
Full-flow area	Af = 3.14 sq ft
Full-flow wetted perimeter	Pf = 6.28 ft
Half Central Angle	Theta = 3.14 radians
Full-flow capacity	Qf = 22.68 cfs
Calculation of Normal Flow Condition	
Half Central Angle ($0 < \theta < 3.14$)	Theta = 1.62 radians
Flow area	An = 1.66 sq ft
Top width	Tn = 2.00 ft
Wetted perimeter	Pn = 3.23 ft
Flow depth	Yn = 1.04 ft
Flow velocity	Vn = 7.35 fps
Discharge	Qn = 12.20 cfs
Percent of Full Flow	Flow = 53.8% of full flow
Normal Depth Froude Number	Fr _n = 1.42 supercritical
Calculation of Critical Flow Condition	
Half Central Angle ($0 < \theta_c < 3.14$)	Theta-c = 1.83 radians
Critical flow area	Ac = 2.08 sq ft
Critical top width	Tc = 1.93 ft
Critical flow depth	Yc = 1.26 ft
Critical flow velocity	Vc = 5.88 fps
Critical Depth Froude Number	Fr _c = 1.00

CIRCULAR CONDUIT FLOW (Normal & Critical Depth Computation)

MHFD-Culvert, Version 4.00 (May 2020)

Project: Monument Ridge East

Pipe ID: PIPE 17

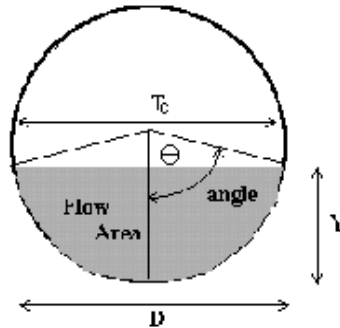

Design Information (Input)	
Pipe Invert Slope	So = 0.0110 ft/ft
Pipe Manning's n-value	n = 0.0130
Pipe Diameter	D = 30.00 inches
Design discharge	Q = 31.80 cfs
Full-Flow Capacity (Calculated)	
Full-flow area	Af = 4.91 sq ft
Full-flow wetted perimeter	Pf = 7.85 ft
Half Central Angle	Theta = 3.14 radians
Full-flow capacity	Qf = 43.13 cfs
Calculation of Normal Flow Condition	
Half Central Angle ($0 < \theta < 3.14$)	Theta = 1.85 radians
Flow area	An = 3.31 sq ft
Top width	Tn = 2.40 ft
Wetted perimeter	Pn = 4.63 ft
Flow depth	Yn = 1.60 ft
Flow velocity	Vn = 9.61 fps
Discharge	Qn = 31.80 cfs
Percent of Full Flow	Flow = 73.7% of full flow
Normal Depth Froude Number	Fr _n = 1.44 supercritical
Calculation of Critical Flow Condition	
Half Central Angle ($0 < \theta_c < 3.14$)	Theta-c = 2.14 radians
Critical flow area	Ac = 4.05 sq ft
Critical top width	Tc = 2.11 ft
Critical flow depth	Yc = 1.92 ft
Critical flow velocity	Vc = 7.86 fps
Critical Depth Froude Number	Fr _c = 1.00

CIRCULAR CONDUIT FLOW (Normal & Critical Depth Computation)

MHFD-Culvert, Version 4.00 (May 2020)

Project: Monument Ridge East

Pipe ID: PIPE 18

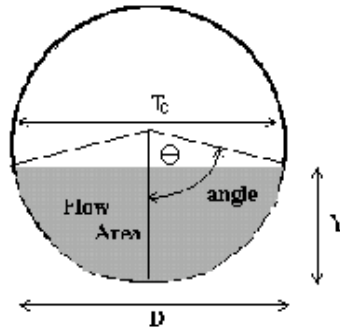

Design Information (Input)	
Pipe Invert Slope	So = 0.0250 ft/ft
Pipe Manning's n-value	n = 0.0130
Pipe Diameter	D = 36.00 inches
Design discharge	Q = 56.50 cfs
Full-Flow Capacity (Calculated)	
Full-flow area	Af = 7.07 sq ft
Full-flow wetted perimeter	Pf = 9.42 ft
Half Central Angle	Theta = 3.14 radians
Full-flow capacity	Qf = 105.74 cfs
Calculation of Normal Flow Condition	
Half Central Angle ($0 < \text{Theta} < 3.14$)	Theta = 1.61 radians
Flow area	An = 3.72 sq ft
Top width	Tn = 3.00 ft
Wetted perimeter	Pn = 4.83 ft
Flow depth	Yn = 1.56 ft
Flow velocity	Vn = 15.21 fps
Discharge	Qn = 56.51 cfs
Percent of Full Flow	Flow = 53.4% of full flow
Normal Depth Froude Number	Fr _n = 2.41 supercritical
Calculation of Critical Flow Condition	
Half Central Angle ($0 < \text{Theta-c} < 3.14$)	Theta-c = 2.24 radians
Critical flow area	Ac = 6.15 sq ft
Critical top width	Tc = 2.34 ft
Critical flow depth	Yc = 2.44 ft
Critical flow velocity	Vc = 9.19 fps
Critical Depth Froude Number	Fr _c = 1.00

CIRCULAR CONDUIT FLOW (Normal & Critical Depth Computation)

MHFD-Culvert, Version 4.00 (May 2020)

Project: Monument Ridge East

Pipe ID: PIPE 19

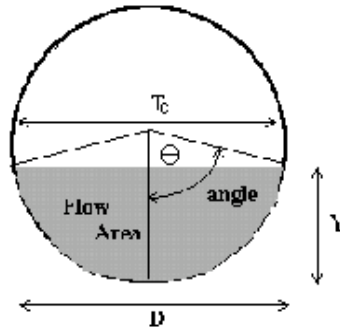

Design Information (Input)	
Pipe Invert Slope	So = 0.0100 ft/ft
Pipe Manning's n-value	n = 0.0130
Pipe Diameter	D = 24.00 inches
Design discharge	Q = 9.50 cfs
Full-Flow Capacity (Calculated)	
Full-flow area	Af = 3.14 sq ft
Full-flow wetted perimeter	Pf = 6.28 ft
Half Central Angle	Theta = 3.14 radians
Full-flow capacity	Qf = 22.68 cfs
Calculation of Normal Flow Condition	
Half Central Angle ($0 < \text{Theta} < 3.14$)	Theta = 1.47 radians
Flow area	An = 1.38 sq ft
Top width	Tn = 1.99 ft
Wetted perimeter	Pn = 2.95 ft
Flow depth	Yn = 0.90 ft
Flow velocity	Vn = 6.90 fps
Discharge	Qn = 9.50 cfs
Percent of Full Flow	Flow = 41.9% of full flow
Normal Depth Froude Number	Fr _n = 1.46 supercritical
Calculation of Critical Flow Condition	
Half Central Angle ($0 < \text{Theta-c} < 3.14$)	Theta-c = 1.67 radians
Critical flow area	Ac = 1.77 sq ft
Critical top width	Tc = 1.99 ft
Critical flow depth	Yc = 1.10 ft
Critical flow velocity	Vc = 5.36 fps
Critical Depth Froude Number	Fr _c = 1.00

CIRCULAR CONDUIT FLOW (Normal & Critical Depth Computation)

MHFD-Culvert, Version 4.00 (May 2020)

Project: Monument Ridge East

Pipe ID: PIPE 20

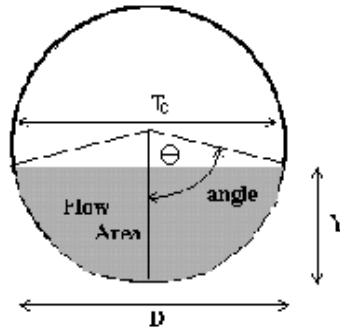

Design Information (Input)	
Pipe Invert Slope	So = 0.0140 ft/ft
Pipe Manning's n-value	n = 0.0130
Pipe Diameter	D = 24.00 inches
Design discharge	Q = 18.90 cfs
Full-Flow Capacity (Calculated)	
Full-flow area	Af = 3.14 sq ft
Full-flow wetted perimeter	Pf = 6.28 ft
Half Central Angle	Theta = 3.14 radians
Full-flow capacity	Qf = 26.84 cfs
Calculation of Normal Flow Condition	
Half Central Angle ($0 < \text{Theta} < 3.14$)	Theta = 1.81 radians
Flow area	An = 2.04 sq ft
Top width	Tn = 1.94 ft
Wetted perimeter	Pn = 3.62 ft
Flow depth	Yn = 1.24 ft
Flow velocity	Vn = 9.26 fps
Discharge	Qn = 18.90 cfs
Percent of Full Flow	Flow = 70.4% of full flow
Normal Depth Froude Number	Fr _n = 1.59 supercritical
Calculation of Critical Flow Condition	
Half Central Angle ($0 < \text{Theta-c} < 3.14$)	Theta-c = 2.17 radians
Critical flow area	Ac = 2.64 sq ft
Critical top width	Tc = 1.65 ft
Critical flow depth	Yc = 1.56 ft
Critical flow velocity	Vc = 7.17 fps
Critical Depth Froude Number	Fr _c = 1.00

CIRCULAR CONDUIT FLOW (Normal & Critical Depth Computation)

MHFD-Culvert, Version 4.00 (May 2020)

Project: **Monument Ridge East**

Pipe ID: **PIPE 21**

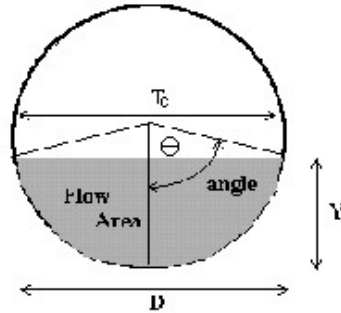

<u>Design Information (Input)</u>	
Pipe Invert Slope	So = 0.0140 ft/ft
Pipe Manning's n-value	n = 0.0130
Pipe Diameter	D = 42.00 inches
Design discharge	Q = 71.40 cfs
<u>Full-Flow Capacity (Calculated)</u>	
Full-flow area	Af = 9.62 sq ft
Full-flow wetted perimeter	Pf = 11.00 ft
Half Central Angle	Theta = 3.14 radians
Full-flow capacity	Qf = 119.36 cfs
<u>Calculation of Normal Flow Condition</u>	
Half Central Angle ($0 < \Theta < 3.14$)	Theta = 1.69 radians
Flow area	An = 5.51 sq ft
Top width	Tn = 3.48 ft
Wetted perimeter	Pn = 5.90 ft
Flow depth	Yn = 1.95 ft
Flow velocity	Vn = 12.96 fps
Discharge	Qn = 71.40 cfs
Percent of Full Flow	Flow = 59.8% of full flow
Normal Depth Froude Number	Fr _n = 1.81 supercritical
<u>Calculation of Critical Flow Condition</u>	
Half Central Angle ($0 < \Theta_c < 3.14$)	Theta-c = 2.11 radians
Critical flow area	Ac = 7.81 sq ft
Critical top width	Tc = 3.01 ft
Critical flow depth	Yc = 2.65 ft
Critical flow velocity	Vc = 9.15 fps
Critical Depth Froude Number	Fr _c = 1.00

CIRCULAR CONDUIT FLOW (Normal & Critical Depth Computation)

MHFD-Culvert, Version 4.00 (May 2020)

Project: **Monument Ridge East**

Pipe ID: **PIPE 22**

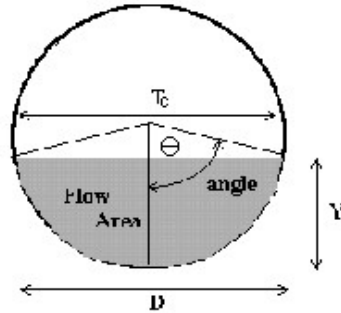

Design Information (Input)	
Pipe Invert Slope	So = 0.0350 ft/ft
Pipe Manning's n-value	n = 0.0130
Pipe Diameter	D = 42.00 inches
Design discharge	Q = 115.50 cfs
Full-Flow Capacity (Calculated)	
Full-flow area	Af = 9.62 sq ft
Full-flow wetted perimeter	Pf = 11.00 ft
Half Central Angle	Theta = 3.14 radians
Full-flow capacity	Qf = 188.73 cfs
Calculation of Normal Flow Condition	
Half Central Angle ($0 < \Theta < 3.14$)	Theta = 1.70 radians
Flow area	An = 5.61 sq ft
Top width	Tn = 3.47 ft
Wetted perimeter	Pn = 5.96 ft
Flow depth	Yn = 1.98 ft
Flow velocity	Vn = 20.60 fps
Discharge	Qn = 115.51 cfs
Percent of Full Flow	Flow = 61.2% of full flow
Normal Depth Froude Number	Fr _n = 2.86 supercritical
Calculation of Critical Flow Condition	
Half Central Angle ($0 < \Theta_c < 3.14$)	Theta-c = 2.56 radians
Critical flow area	Ac = 9.25 sq ft
Critical top width	Tc = 1.91 ft
Critical flow depth	Yc = 3.22 ft
Critical flow velocity	Vc = 12.48 fps
Critical Depth Froude Number	Fr _c = 1.00

CIRCULAR CONDUIT FLOW (Normal & Critical Depth Computation)

MHFD-Culvert, Version 4.00 (May 2020)

Project: Monument Ridge East

Pipe ID: PIPE 23

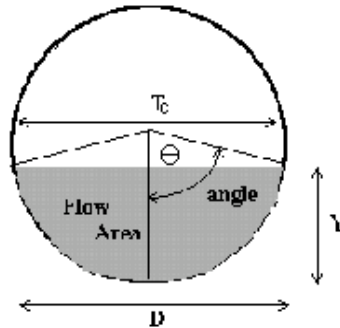

Design Information (Input)	
Pipe Invert Slope	So = 0.0100 ft/ft
Pipe Manning's n-value	n = 0.0130
Pipe Diameter	D = 18.00 inches
Design discharge	Q = 1.80 cfs
Full-Flow Capacity (Calculated)	
Full-flow area	Af = 1.77 sq ft
Full-flow wetted perimeter	Pf = 4.71 ft
Half Central Angle	Theta = 3.14 radians
Full-flow capacity	Qf = 10.53 cfs
Calculation of Normal Flow Condition	
Half Central Angle ($0 < \theta < 3.14$)	Theta = 1.11 radians
Flow area	An = 0.40 sq ft
Top width	Tn = 1.35 ft
Wetted perimeter	Pn = 1.67 ft
Flow depth	Yn = 0.42 ft
Flow velocity	Vn = 4.45 fps
Discharge	Qn = 1.80 cfs
Percent of Full Flow	Flow = 17.1% of full flow
Normal Depth Froude Number	Fr _n = 1.43 supercritical
Calculation of Critical Flow Condition	
Half Central Angle ($0 < \theta_c < 3.14$)	Theta-c = 1.24 radians
Critical flow area	Ac = 0.52 sq ft
Critical top width	Tc = 1.42 ft
Critical flow depth	Yc = 0.50 ft
Critical flow velocity	Vc = 3.45 fps
Critical Depth Froude Number	Fr _c = 1.00

CIRCULAR CONDUIT FLOW (Normal & Critical Depth Computation)

MHFD-Culvert, Version 4.00 (May 2020)

Project: Monument Ridge East

Pipe ID: PIPE 24

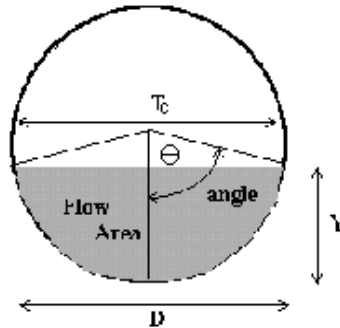

Design Information (Input)	
Pipe Invert Slope	So = 0.0100 ft/ft
Pipe Manning's n-value	n = 0.0130
Pipe Diameter	D = 18.00 inches
Design discharge	Q = 3.50 cfs
Full-Flow Capacity (Calculated)	
Full-flow area	Af = 1.77 sq ft
Full-flow wetted perimeter	Pf = 4.71 ft
Half Central Angle	Theta = 3.14 radians
Full-flow capacity	Qf = 10.53 cfs
Calculation of Normal Flow Condition	
Half Central Angle ($0 < \text{Theta} < 3.14$)	Theta = 1.36 radians
Flow area	An = 0.65 sq ft
Top width	Tn = 1.47 ft
Wetted perimeter	Pn = 2.04 ft
Flow depth	Yn = 0.60 ft
Flow velocity	Vn = 5.36 fps
Discharge	Qn = 3.50 cfs
Percent of Full Flow	Flow = 33.2% of full flow
Normal Depth Froude Number	Fr _n = 1.41 supercritical
Calculation of Critical Flow Condition	
Half Central Angle ($0 < \text{Theta-c} < 3.14$)	Theta-c = 1.52 radians
Critical flow area	Ac = 0.83 sq ft
Critical top width	Tc = 1.50 ft
Critical flow depth	Yc = 0.71 ft
Critical flow velocity	Vc = 4.22 fps
Critical Depth Froude Number	Fr _c = 1.00

CIRCULAR CONDUIT FLOW (Normal & Critical Depth Computation)

MHFD-Culvert, Version 4.00 (May 2020)

Project: Monument Ridge East

Pipe ID: PIPE 25

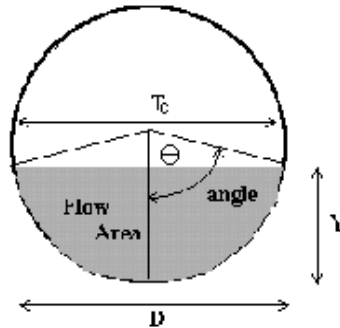

Design Information (Input)	
Pipe Invert Slope	So = 0.0100 ft/ft
Pipe Manning's n-value	n = 0.0130
Pipe Diameter	D = 18.00 inches
Design discharge	Q = 5.30 cfs
Full-Flow Capacity (Calculated)	
Full-flow area	Af = 1.77 sq ft
Full-flow wetted perimeter	Pf = 4.71 ft
Half Central Angle	Theta = 3.14 radians
Full-flow capacity	Qf = 10.53 cfs
Calculation of Normal Flow Condition	
Half Central Angle ($0 < \text{Theta} < 3.14$)	Theta = 1.57 radians
Flow area	An = 0.89 sq ft
Top width	Tn = 1.50 ft
Wetted perimeter	Pn = 2.36 ft
Flow depth	Yn = 0.75 ft
Flow velocity	Vn = 5.97 fps
Discharge	Qn = 5.30 cfs
Percent of Full Flow	Flow = 50.3% of full flow
Normal Depth Froude Number	Fr _n = 1.37 supercritical
Calculation of Critical Flow Condition	
Half Central Angle ($0 < \text{Theta-c} < 3.14$)	Theta-c = 1.75 radians
Critical flow area	Ac = 1.09 sq ft
Critical top width	Tc = 1.47 ft
Critical flow depth	Yc = 0.89 ft
Critical flow velocity	Vc = 4.87 fps
Critical Depth Froude Number	Fr _c = 1.00

CIRCULAR CONDUIT FLOW (Normal & Critical Depth Computation)

MHFD-Culvert, Version 4.00 (May 2020)

Project: Monument Ridge East

Pipe ID: PIPE 26

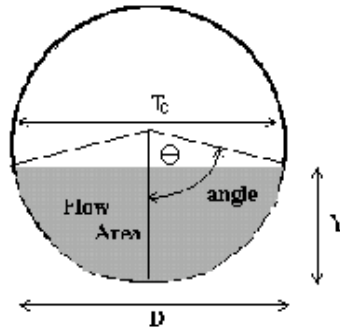

Design Information (Input)	
Pipe Invert Slope	So = 0.0100 ft/ft
Pipe Manning's n-value	n = 0.0130
Pipe Diameter	D = 24.00 inches
Design discharge	Q = 12.80 cfs
Full-Flow Capacity (Calculated)	
Full-flow area	Af = 3.14 sq ft
Full-flow wetted perimeter	Pf = 6.28 ft
Half Central Angle	Theta = 3.14 radians
Full-flow capacity	Qf = 22.68 cfs
Calculation of Normal Flow Condition	
Half Central Angle ($0 < \text{Theta} < 3.14$)	Theta = 1.65 radians
Flow area	An = 1.72 sq ft
Top width	Tn = 1.99 ft
Wetted perimeter	Pn = 3.29 ft
Flow depth	Yn = 1.08 ft
Flow velocity	Vn = 7.44 fps
Discharge	Qn = 12.80 cfs
Percent of Full Flow	Flow = 56.4% of full flow
Normal Depth Froude Number	Fr _n = 1.41 supercritical
Calculation of Critical Flow Condition	
Half Central Angle ($0 < \text{Theta-c} < 3.14$)	Theta-c = 1.86 radians
Critical flow area	Ac = 2.14 sq ft
Critical top width	Tc = 1.92 ft
Critical flow depth	Yc = 1.29 ft
Critical flow velocity	Vc = 5.99 fps
Critical Depth Froude Number	Fr _c = 1.00

CIRCULAR CONDUIT FLOW (Normal & Critical Depth Computation)

MHFD-Culvert, Version 4.00 (May 2020)

Project: Monument Ridge East

Pipe ID: PIPE 27

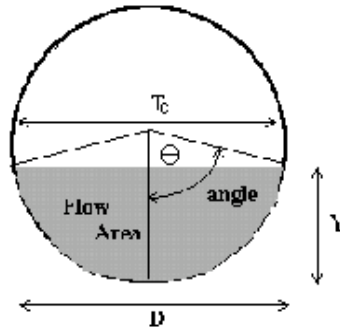

Design Information (Input)	
Pipe Invert Slope	So = 0.0200 ft/ft
Pipe Manning's n-value	n = 0.0130
Pipe Diameter	D = 24.00 inches
Design discharge	Q = 18.10 cfs
Full-Flow Capacity (Calculated)	
Full-flow area	Af = 3.14 sq ft
Full-flow wetted perimeter	Pf = 6.28 ft
Half Central Angle	Theta = 3.14 radians
Full-flow capacity	Qf = 32.08 cfs
Calculation of Normal Flow Condition	
Half Central Angle ($0 < \text{Theta} < 3.14$)	Theta = 1.65 radians
Flow area	An = 1.72 sq ft
Top width	Tn = 1.99 ft
Wetted perimeter	Pn = 3.29 ft
Flow depth	Yn = 1.08 ft
Flow velocity	Vn = 10.52 fps
Discharge	Qn = 18.10 cfs
Percent of Full Flow	Flow = 56.4% of full flow
Normal Depth Froude Number	Fr _n = 2.00 supercritical
Calculation of Critical Flow Condition	
Half Central Angle ($0 < \text{Theta-c} < 3.14$)	Theta-c = 2.13 radians
Critical flow area	Ac = 2.58 sq ft
Critical top width	Tc = 1.69 ft
Critical flow depth	Yc = 1.53 ft
Critical flow velocity	Vc = 7.01 fps
Critical Depth Froude Number	Fr _c = 1.00

CIRCULAR CONDUIT FLOW (Normal & Critical Depth Computation)

MHFD-Culvert, Version 4.00 (May 2020)

Project: Monument Ridge East

Pipe ID: PIPE 28

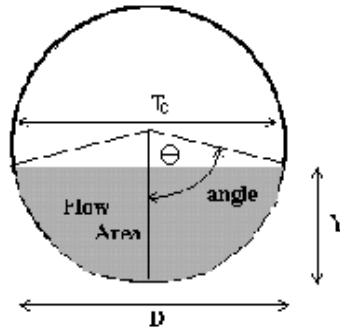

Design Information (Input)	
Pipe Invert Slope	So = 0.0300 ft/ft
Pipe Manning's n-value	n = 0.0130
Pipe Diameter	D = 24.00 inches
Design discharge	Q = 27.90 cfs
Full-Flow Capacity (Calculated)	
Full-flow area	Af = 3.14 sq ft
Full-flow wetted perimeter	Pf = 6.28 ft
Half Central Angle	Theta = 3.14 radians
Full-flow capacity	Qf = 39.29 cfs
Calculation of Normal Flow Condition	
Half Central Angle ($0 < \theta < 3.14$)	Theta = 1.82 radians
Flow area	An = 2.06 sq ft
Top width	Tn = 1.94 ft
Wetted perimeter	Pn = 3.64 ft
Flow depth	Yn = 1.24 ft
Flow velocity	Vn = 13.57 fps
Discharge	Qn = 27.90 cfs
Percent of Full Flow	Flow = 71.0% of full flow
Normal Depth Froude Number	Fr _n = 2.32 supercritical
Calculation of Critical Flow Condition	
Half Central Angle ($0 < \theta_c < 3.14$)	Theta-c = 2.54 radians
Critical flow area	Ac = 3.01 sq ft
Critical top width	Tc = 1.13 ft
Critical flow depth	Yc = 1.83 ft
Critical flow velocity	Vc = 9.27 fps
Critical Depth Froude Number	Fr _c = 1.00

CIRCULAR CONDUIT FLOW (Normal & Critical Depth Computation)

MHFD-Culvert, Version 4.00 (May 2020)

Project: Monument Ridge East

Pipe ID: PIPE 29 POND 2 OUT

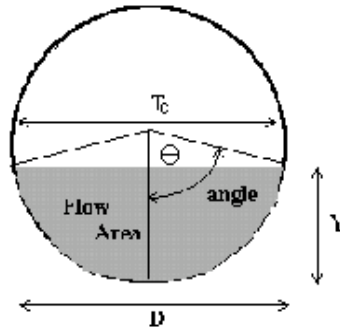

Design Information (Input)	
Pipe Invert Slope	So = 0.0550 ft/ft
Pipe Manning's n-value	n = 0.0130
Pipe Diameter	D = 24.00 inches
Design discharge	Q = 28.30 cfs
Full-Flow Capacity (Calculated)	
Full-flow area	Af = 3.14 sq ft
Full-flow wetted perimeter	Pf = 6.28 ft
Half Central Angle	Theta = 3.14 radians
Full-flow capacity	Qf = 53.20 cfs
Calculation of Normal Flow Condition	
Half Central Angle ($0 < \text{Theta} < 3.14$)	Theta = 1.61 radians
Flow area	An = 1.65 sq ft
Top width	Tn = 2.00 ft
Wetted perimeter	Pn = 3.22 ft
Flow depth	Yn = 1.04 ft
Flow velocity	Vn = 17.20 fps
Discharge	Qn = 28.30 cfs
Percent of Full Flow	Flow = 53.2% of full flow
Normal Depth Froude Number	Fr _n = 3.34 supercritical
Calculation of Critical Flow Condition	
Half Central Angle ($0 < \text{Theta-c} < 3.14$)	Theta-c = 2.56 radians
Critical flow area	Ac = 3.02 sq ft
Critical top width	Tc = 1.10 ft
Critical flow depth	Yc = 1.83 ft
Critical flow velocity	Vc = 9.38 fps
Critical Depth Froude Number	Fr _c = 1.00

CIRCULAR CONDUIT FLOW (Normal & Critical Depth Computation)

MHFD-Culvert, Version 4.00 (May 2020)

Project: **Monument Ridge East**

Pipe ID: **PIPE 30**

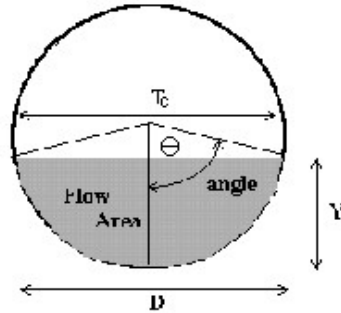

Design Information (Input)	
Pipe Invert Slope	So = 0.0080 ft/ft
Pipe Manning's n-value	n = 0.0130
Pipe Diameter	D = 30.00 inches
Design discharge	Q = 21.90 cfs
Full-Flow Capacity (Calculated)	
Full-flow area	Af = 4.91 sq ft
Full-flow wetted perimeter	Pf = 7.85 ft
Half Central Angle	Theta = 3.14 radians
Full-flow capacity	Qf = 36.79 cfs
Calculation of Normal Flow Condition	
Half Central Angle ($0 < \Theta < 3.14$)	Theta = 1.68 radians
Flow area	An = 2.80 sq ft
Top width	Tn = 2.48 ft
Wetted perimeter	Pn = 4.21 ft
Flow depth	Yn = 1.39 ft
Flow velocity	Vn = 7.82 fps
Discharge	Qn = 21.90 cfs
Percent of Full Flow	Flow = 59.5% of full flow
Normal Depth Froude Number	Fr _n = 1.30 supercritical
Calculation of Critical Flow Condition	
Half Central Angle ($0 < \Theta_c < 3.14$)	Theta-c = 1.85 radians
Critical flow area	Ac = 3.30 sq ft
Critical top width	Tc = 2.41 ft
Critical flow depth	Yc = 1.59 ft
Critical flow velocity	Vc = 6.64 fps
Critical Depth Froude Number	Fr _c = 1.00

CIRCULAR CONDUIT FLOW (Normal & Critical Depth Computation)

MHFD-Culvert, Version 4.00 (May 2020)

Project: **Monument Ridge East**

Pipe ID: **PIPE 31**

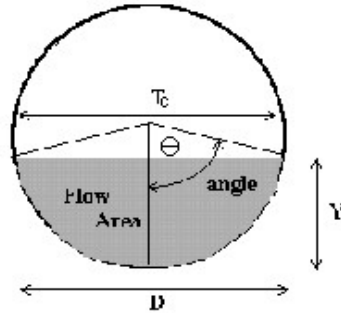

Design Information (Input)	
Pipe Invert Slope	So = 0.0050 ft/ft
Pipe Manning's n-value	n = 0.0130
Pipe Diameter	D = 36.00 inches
Design discharge	Q = 38.30 cfs
Full-Flow Capacity (Calculated)	
Full-flow area	Af = 7.07 sq ft
Full-flow wetted perimeter	Pf = 9.42 ft
Half Central Angle	Theta = 3.14 radians
Full-flow capacity	Qf = 47.29 cfs
Calculation of Normal Flow Condition	
Half Central Angle ($0 < \Theta < 3.14$)	Theta = 1.88 radians
Flow area	An = 4.88 sq ft
Top width	Tn = 2.86 ft
Wetted perimeter	Pn = 5.64 ft
Flow depth	Yn = 1.96 ft
Flow velocity	Vn = 7.36 fps
Discharge	Qn = 35.90 cfs
Percent of Full Flow	Flow = 75.9% of full flow
Normal Depth Froude Number	Fr _n = 0.99 subcritical
Calculation of Critical Flow Condition	
Half Central Angle ($0 < \Theta_c < 3.14$)	Theta-c = 1.87 radians
Critical flow area	Ac = 4.86 sq ft
Critical top width	Tc = 2.86 ft
Critical flow depth	Yc = 1.95 ft
Critical flow velocity	Vc = 7.88 fps
Critical Depth Froude Number	Fr _c = 1.07

CIRCULAR CONDUIT FLOW (Normal & Critical Depth Computation)

MHFD-Culvert, Version 4.00 (May 2020)

Project: **Monument Ridge East**

Pipe ID: **PIPE 32 POND 3 OUT**

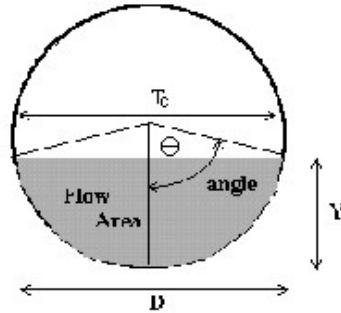

Design Information (Input)	
Pipe Invert Slope	So = 0.0050 ft/ft
Pipe Manning's n-value	n = 0.0130
Pipe Diameter	D = 18.00 inches
Design discharge	Q = 5.60 cfs
Full-Flow Capacity (Calculated)	
Full-flow area	Af = 1.77 sq ft
Full-flow wetted perimeter	Pf = 4.71 ft
Half Central Angle	Theta = 3.14 radians
Full-flow capacity	Qf = 7.45 cfs
Calculation of Normal Flow Condition	
Half Central Angle ($0 < \Theta < 3.14$)	Theta = 1.87 radians
Flow area	An = 1.21 sq ft
Top width	Tn = 1.43 ft
Wetted perimeter	Pn = 2.80 ft
Flow depth	Yn = 0.97 ft
Flow velocity	Vn = 4.63 fps
Discharge	Qn = 5.60 cfs
Percent of Full Flow	Flow = 75.2% of full flow
Normal Depth Froude Number	Fr _n = 0.89 subcritical
Calculation of Critical Flow Condition	
Half Central Angle ($0 < \Theta_c < 3.14$)	Theta-c = 1.79 radians
Critical flow area	Ac = 1.13 sq ft
Critical top width	Tc = 1.46 ft
Critical flow depth	Yc = 0.91 ft
Critical flow velocity	Vc = 4.98 fps
Critical Depth Froude Number	Fr _c = 1.00

CIRCULAR CONDUIT FLOW (Normal & Critical Depth Computation)

MHFD-Culvert, Version 4.00 (May 2020)

Project: Monument Ridge East

Pipe ID: PIPE 33

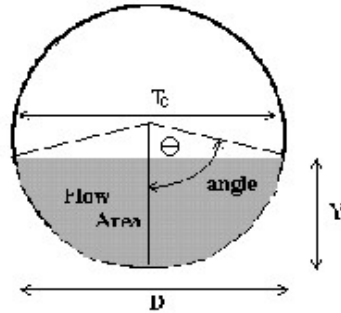

<u>Design Information (Input)</u>			
Pipe Invert Slope	So = <table border="1" style="display: inline-table; vertical-align: middle;"><tr><td style="text-align: center;">0.0080</td><td style="text-align: left;">ft/ft</td></tr></table>	0.0080	ft/ft
0.0080	ft/ft		
Pipe Manning's n-value	n = <table border="1" style="display: inline-table; vertical-align: middle;"><tr><td style="text-align: center;">0.0130</td><td></td></tr></table>	0.0130	
0.0130			
Pipe Diameter	D = <table border="1" style="display: inline-table; vertical-align: middle;"><tr><td style="text-align: center;">36.00</td><td style="text-align: left;">inches</td></tr></table>	36.00	inches
36.00	inches		
Design discharge	Q = <table border="1" style="display: inline-table; vertical-align: middle;"><tr><td style="text-align: center;">33.90</td><td style="text-align: left;">cfs</td></tr></table>	33.90	cfs
33.90	cfs		
<u>Full-Flow Capacity (Calculated)</u>			
Full-flow area	Af = <table border="1" style="display: inline-table; vertical-align: middle;"><tr><td style="text-align: center;">7.07</td><td style="text-align: left;">sq ft</td></tr></table>	7.07	sq ft
7.07	sq ft		
Full-flow wetted perimeter	Pf = <table border="1" style="display: inline-table; vertical-align: middle;"><tr><td style="text-align: center;">9.42</td><td style="text-align: left;">ft</td></tr></table>	9.42	ft
9.42	ft		
Half Central Angle	Theta = <table border="1" style="display: inline-table; vertical-align: middle;"><tr><td style="text-align: center;">3.14</td><td style="text-align: left;">radians</td></tr></table>	3.14	radians
3.14	radians		
Full-flow capacity	Qf = <table border="1" style="display: inline-table; vertical-align: middle;"><tr><td style="text-align: center;">59.82</td><td style="text-align: left;">cfs</td></tr></table>	59.82	cfs
59.82	cfs		
<u>Calculation of Normal Flow Condition</u>			
Half Central Angle ($0 < \theta < 3.14$)	Theta = <table border="1" style="display: inline-table; vertical-align: middle;"><tr><td style="text-align: center;">1.65</td><td style="text-align: left;">radians</td></tr></table>	1.65	radians
1.65	radians		
Flow area	An = <table border="1" style="display: inline-table; vertical-align: middle;"><tr><td style="text-align: center;">3.89</td><td style="text-align: left;">sq ft</td></tr></table>	3.89	sq ft
3.89	sq ft		
Top width	Tn = <table border="1" style="display: inline-table; vertical-align: middle;"><tr><td style="text-align: center;">2.99</td><td style="text-align: left;">ft</td></tr></table>	2.99	ft
2.99	ft		
Wetted perimeter	Pn = <table border="1" style="display: inline-table; vertical-align: middle;"><tr><td style="text-align: center;">4.95</td><td style="text-align: left;">ft</td></tr></table>	4.95	ft
4.95	ft		
Flow depth	Yn = <table border="1" style="display: inline-table; vertical-align: middle;"><tr><td style="text-align: center;">1.62</td><td style="text-align: left;">ft</td></tr></table>	1.62	ft
1.62	ft		
Flow velocity	Vn = <table border="1" style="display: inline-table; vertical-align: middle;"><tr><td style="text-align: center;">8.73</td><td style="text-align: left;">fps</td></tr></table>	8.73	fps
8.73	fps		
Discharge	Qn = <table border="1" style="display: inline-table; vertical-align: middle;"><tr><td style="text-align: center;">33.90</td><td style="text-align: left;">cfs</td></tr></table>	33.90	cfs
33.90	cfs		
Percent of Full Flow	Flow = <table border="1" style="display: inline-table; vertical-align: middle;"><tr><td style="text-align: center;">56.7%</td><td style="text-align: left;">of full flow</td></tr></table>	56.7%	of full flow
56.7%	of full flow		
Normal Depth Froude Number	Fr _n = <table border="1" style="display: inline-table; vertical-align: middle;"><tr><td style="text-align: center;">1.35</td><td style="text-align: left;">supercritical</td></tr></table>	1.35	supercritical
1.35	supercritical		
<u>Calculation of Critical Flow Condition</u>			
Half Central Angle ($0 < \theta_c < 3.14$)	Theta-c = <table border="1" style="display: inline-table; vertical-align: middle;"><tr><td style="text-align: center;">1.83</td><td style="text-align: left;">radians</td></tr></table>	1.83	radians
1.83	radians		
Critical flow area	Ac = <table border="1" style="display: inline-table; vertical-align: middle;"><tr><td style="text-align: center;">4.69</td><td style="text-align: left;">sq ft</td></tr></table>	4.69	sq ft
4.69	sq ft		
Critical top width	Tc = <table border="1" style="display: inline-table; vertical-align: middle;"><tr><td style="text-align: center;">2.90</td><td style="text-align: left;">ft</td></tr></table>	2.90	ft
2.90	ft		
Critical flow depth	Yc = <table border="1" style="display: inline-table; vertical-align: middle;"><tr><td style="text-align: center;">1.89</td><td style="text-align: left;">ft</td></tr></table>	1.89	ft
1.89	ft		
Critical flow velocity	Vc = <table border="1" style="display: inline-table; vertical-align: middle;"><tr><td style="text-align: center;">7.22</td><td style="text-align: left;">fps</td></tr></table>	7.22	fps
7.22	fps		
Critical Depth Froude Number	Fr _c = <table border="1" style="display: inline-table; vertical-align: middle;"><tr><td style="text-align: center;">1.00</td><td></td></tr></table>	1.00	
1.00			

CIRCULAR CONDUIT FLOW (Normal & Critical Depth Computation)

MHFD-Culvert, Version 4.00 (May 2020)

Project: **Monument Ridge East**

Pipe ID: **PIPE 34**

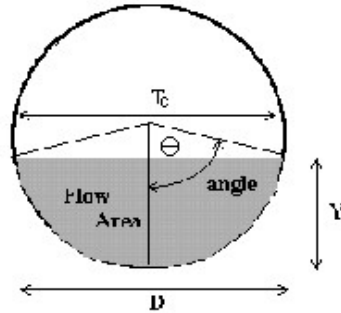

<u>Design Information (Input)</u>	
Pipe Invert Slope	So = 0.0090 ft/ft
Pipe Manning's n-value	n = 0.0130
Pipe Diameter	D = 36.00 inches
Design discharge	Q = 33.90 cfs
<u>Full-Flow Capacity (Calculated)</u>	
Full-flow area	Af = 7.07 sq ft
Full-flow wetted perimeter	Pf = 9.42 ft
Half Central Angle	Theta = 3.14 radians
Full-flow capacity	Qf = 63.45 cfs
<u>Calculation of Normal Flow Condition</u>	
Half Central Angle ($0 < \Theta < 3.14$)	Theta = 1.61 radians
Flow area	An = 3.72 sq ft
Top width	Tn = 3.00 ft
Wetted perimeter	Pn = 4.83 ft
Flow depth	Yn = 1.56 ft
Flow velocity	Vn = 9.12 fps
Discharge	Qn = 33.90 cfs
Percent of Full Flow	Flow = 53.4% of full flow
Normal Depth Froude Number	Fr _n = 1.44 supercritical
<u>Calculation of Critical Flow Condition</u>	
Half Central Angle ($0 < \Theta_c < 3.14$)	Theta-c = 1.83 radians
Critical flow area	Ac = 4.69 sq ft
Critical top width	Tc = 2.90 ft
Critical flow depth	Yc = 1.89 ft
Critical flow velocity	Vc = 7.22 fps
Critical Depth Froude Number	Fr _c = 1.00

CIRCULAR CONDUIT FLOW (Normal & Critical Depth Computation)

MHFD-Culvert, Version 4.00 (May 2020)

Project: Monument Ridge East

Pipe ID: PIPE 35

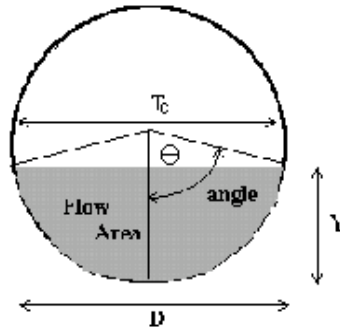

Design Information (Input)	
Pipe Invert Slope	So = 0.0200 ft/ft
Pipe Manning's n-value	n = 0.0130
Pipe Diameter	D = 24.00 inches
Design discharge	Q = 17.50 cfs
Full-Flow Capacity (Calculated)	
Full-flow area	Af = 3.14 sq ft
Full-flow wetted perimeter	Pf = 6.28 ft
Half Central Angle	Theta = 3.14 radians
Full-flow capacity	Qf = 32.08 cfs
Calculation of Normal Flow Condition	
Half Central Angle ($0 < \theta < 3.14$)	Theta = 1.62 radians
Flow area	An = 1.68 sq ft
Top width	Tn = 2.00 ft
Wetted perimeter	Pn = 3.25 ft
Flow depth	Yn = 1.05 ft
Flow velocity	Vn = 10.43 fps
Discharge	Qn = 17.50 cfs
Percent of Full Flow	Flow = 54.6% of full flow
Normal Depth Froude Number	Fr _n = 2.01 supercritical
Calculation of Critical Flow Condition	
Half Central Angle ($0 < \theta_c < 3.14$)	Theta-c = 2.10 radians
Critical flow area	Ac = 2.54 sq ft
Critical top width	Tc = 1.72 ft
Critical flow depth	Yc = 1.51 ft
Critical flow velocity	Vc = 6.89 fps
Critical Depth Froude Number	Fr _c = 1.00

CIRCULAR CONDUIT FLOW (Normal & Critical Depth Computation)

MHFD-Culvert, Version 4.00 (May 2020)

Project: Monument Ridge East

Pipe ID: PIPE 36

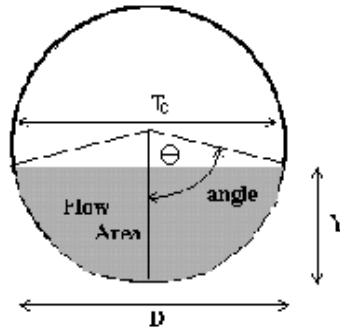

Design Information (Input)	
Pipe Invert Slope	So = 0.0200 ft/ft
Pipe Manning's n-value	n = 0.0130
Pipe Diameter	D = 30.00 inches
Design discharge	Q = 34.90 cfs
Full-Flow Capacity (Calculated)	
Full-flow area	Af = 4.91 sq ft
Full-flow wetted perimeter	Pf = 7.85 ft
Half Central Angle	Theta = 3.14 radians
Full-flow capacity	Qf = 58.16 cfs
Calculation of Normal Flow Condition	
Half Central Angle ($0 < \text{Theta} < 3.14$)	Theta = 1.69 radians
Flow area	An = 2.82 sq ft
Top width	Tn = 2.48 ft
Wetted perimeter	Pn = 4.22 ft
Flow depth	Yn = 1.40 ft
Flow velocity	Vn = 12.39 fps
Discharge	Qn = 34.90 cfs
Percent of Full Flow	Flow = 60.0% of full flow
Normal Depth Froude Number	Fr _n = 2.05 supercritical
Calculation of Critical Flow Condition	
Half Central Angle ($0 < \text{Theta-c} < 3.14$)	Theta-c = 2.22 radians
Critical flow area	Ac = 4.22 sq ft
Critical top width	Tc = 1.99 ft
Critical flow depth	Yc = 2.01 ft
Critical flow velocity	Vc = 8.27 fps
Critical Depth Froude Number	Fr _c = 1.00

CIRCULAR CONDUIT FLOW (Normal & Critical Depth Computation)

MHFD-Culvert, Version 4.00 (May 2020)

Project: Monument Ridge East

Pipe ID: PIPE 37A

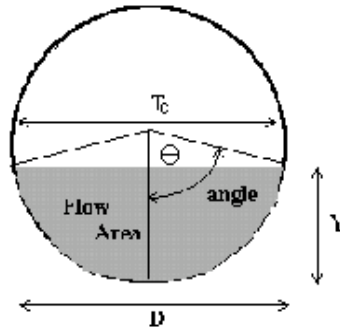

Design Information (Input)	
Pipe Invert Slope	So = 0.0170 ft/ft
Pipe Manning's n-value	n = 0.0130
Pipe Diameter	D = 24.00 inches
Design discharge	Q = 15.10 cfs
Full-Flow Capacity (Calculated)	
Full-flow area	Af = 3.14 sq ft
Full-flow wetted perimeter	Pf = 6.28 ft
Half Central Angle	Theta = 3.14 radians
Full-flow capacity	Qf = 29.58 cfs
Calculation of Normal Flow Condition	
Half Central Angle ($0 < \theta < 3.14$)	Theta = 1.58 radians
Flow area	An = 1.60 sq ft
Top width	Tn = 2.00 ft
Wetted perimeter	Pn = 3.17 ft
Flow depth	Yn = 1.01 ft
Flow velocity	Vn = 9.46 fps
Discharge	Qn = 15.10 cfs
Percent of Full Flow	Flow = 51.1% of full flow
Normal Depth Froude Number	Fr _n = 1.87 supercritical
Calculation of Critical Flow Condition	
Half Central Angle ($0 < \theta_c < 3.14$)	Theta-c = 1.98 radians
Critical flow area	Ac = 2.35 sq ft
Critical top width	Tc = 1.83 ft
Critical flow depth	Yc = 1.40 ft
Critical flow velocity	Vc = 6.43 fps
Critical Depth Froude Number	Fr _c = 1.00

CIRCULAR CONDUIT FLOW (Normal & Critical Depth Computation)

MHFD-Culvert, Version 4.00 (May 2020)

Project: Monument Ridge East

Pipe ID: PIPE 37B

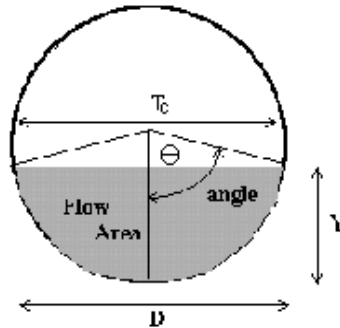

Design Information (Input)	
Pipe Invert Slope	So = 0.0170 ft/ft
Pipe Manning's n-value	n = 0.0130
Pipe Diameter	D = 30.00 inches
Design discharge	Q = 30.20 cfs
Full-Flow Capacity (Calculated)	
Full-flow area	Af = 4.91 sq ft
Full-flow wetted perimeter	Pf = 7.85 ft
Half Central Angle	Theta = 3.14 radians
Full-flow capacity	Qf = 53.62 cfs
Calculation of Normal Flow Condition	
Half Central Angle ($0 < \text{Theta} < 3.14$)	Theta = 1.64 radians
Flow area	An = 2.69 sq ft
Top width	Tn = 2.49 ft
Wetted perimeter	Pn = 4.11 ft
Flow depth	Yn = 1.34 ft
Flow velocity	Vn = 11.25 fps
Discharge	Qn = 30.20 cfs
Percent of Full Flow	Flow = 56.3% of full flow
Normal Depth Froude Number	Fr _n = 1.91 supercritical
Calculation of Critical Flow Condition	
Half Central Angle ($0 < \text{Theta-c} < 3.14$)	Theta-c = 2.09 radians
Critical flow area	Ac = 3.94 sq ft
Critical top width	Tc = 2.17 ft
Critical flow depth	Yc = 1.87 ft
Critical flow velocity	Vc = 7.66 fps
Critical Depth Froude Number	Fr _c = 1.00

CIRCULAR CONDUIT FLOW (Normal & Critical Depth Computation)

MHFD-Culvert, Version 4.00 (May 2020)

Project: Monument Ridge East

Pipe ID: PIPE 37C

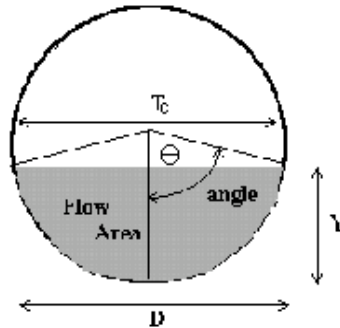

Design Information (Input)	
Pipe Invert Slope	So = 0.0200 ft/ft
Pipe Manning's n-value	n = 0.0130
Pipe Diameter	D = 18.00 inches
Design discharge	Q = 11.70 cfs
Full-Flow Capacity (Calculated)	
Full-flow area	Af = 1.77 sq ft
Full-flow wetted perimeter	Pf = 4.71 ft
Half Central Angle	Theta = 3.14 radians
Full-flow capacity	Qf = 14.90 cfs
Calculation of Normal Flow Condition	
Half Central Angle ($0 < \theta < 3.14$)	Theta = 1.91 radians
Flow area	An = 1.25 sq ft
Top width	Tn = 1.41 ft
Wetted perimeter	Pn = 2.87 ft
Flow depth	Yn = 1.00 ft
Flow velocity	Vn = 9.33 fps
Discharge	Qn = 11.70 cfs
Percent of Full Flow	Flow = 78.6% of full flow
Normal Depth Froude Number	Fr _n = 1.75 supercritical
Calculation of Critical Flow Condition	
Half Central Angle ($0 < \theta_c < 3.14$)	Theta-c = 2.40 radians
Critical flow area	Ac = 1.63 sq ft
Critical top width	Tc = 1.02 ft
Critical flow depth	Yc = 1.30 ft
Critical flow velocity	Vc = 7.18 fps
Critical Depth Froude Number	Fr _c = 1.00

CIRCULAR CONDUIT FLOW (Normal & Critical Depth Computation)

MHFD-Culvert, Version 4.00 (May 2020)

Project: Monument Ridge East

Pipe ID: PIPE 37D

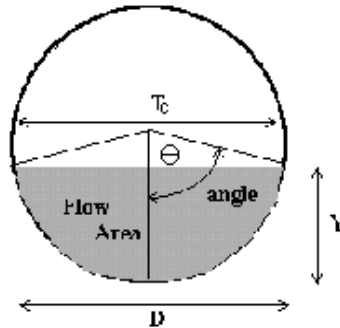

Design Information (Input)	
Pipe Invert Slope	So = 0.0200 ft/ft
Pipe Manning's n-value	n = 0.0130
Pipe Diameter	D = 30.00 inches
Design discharge	Q = 42.00 cfs
Full-Flow Capacity (Calculated)	
Full-flow area	Af = 4.91 sq ft
Full-flow wetted perimeter	Pf = 7.85 ft
Half Central Angle	Theta = 3.14 radians
Full-flow capacity	Qf = 58.16 cfs
Calculation of Normal Flow Condition	
Half Central Angle ($0 < \theta < 3.14$)	Theta = 1.83 radians
Flow area	An = 3.25 sq ft
Top width	Tn = 2.41 ft
Wetted perimeter	Pn = 4.58 ft
Flow depth	Yn = 1.57 ft
Flow velocity	Vn = 12.90 fps
Discharge	Qn = 42.00 cfs
Percent of Full Flow	Flow = 72.2% of full flow
Normal Depth Froude Number	Fr _n = 1.96 supercritical
Calculation of Critical Flow Condition	
Half Central Angle ($0 < \theta_c < 3.14$)	Theta-c = 2.40 radians
Critical flow area	Ac = 4.53 sq ft
Critical top width	Tc = 1.69 ft
Critical flow depth	Yc = 2.17 ft
Critical flow velocity	Vc = 9.28 fps
Critical Depth Froude Number	Fr _c = 1.00

CIRCULAR CONDUIT FLOW (Normal & Critical Depth Computation)

MHFD-Culvert, Version 4.00 (May 2020)

Project: Monument Ridge East

Pipe ID: PIPE 38

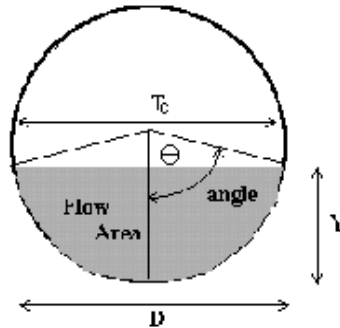

Design Information (Input)	
Pipe Invert Slope	So = 0.0300 ft/ft
Pipe Manning's n-value	n = 0.0130
Pipe Diameter	D = 30.00 inches
Design discharge	Q = 53.70 cfs
Full-Flow Capacity (Calculated)	
Full-flow area	Af = 4.91 sq ft
Full-flow wetted perimeter	Pf = 7.85 ft
Half Central Angle	Theta = 3.14 radians
Full-flow capacity	Qf = 71.24 cfs
Calculation of Normal Flow Condition	
Half Central Angle ($0 < \theta < 3.14$)	Theta = 1.87 radians
Flow area	An = 3.37 sq ft
Top width	Tn = 2.39 ft
Wetted perimeter	Pn = 4.68 ft
Flow depth	Yn = 1.62 ft
Flow velocity	Vn = 15.94 fps
Discharge	Qn = 53.70 cfs
Percent of Full Flow	Flow = 75.4% of full flow
Normal Depth Froude Number	Fr _n = 2.37 supercritical
Calculation of Critical Flow Condition	
Half Central Angle ($0 < \theta_c < 3.14$)	Theta-c = 2.63 radians
Critical flow area	Ac = 4.78 sq ft
Critical top width	Tc = 1.22 ft
Critical flow depth	Yc = 2.34 ft
Critical flow velocity	Vc = 11.24 fps
Critical Depth Froude Number	Fr _c = 1.00

CIRCULAR CONDUIT FLOW (Normal & Critical Depth Computation)

MHFD-Culvert, Version 4.00 (May 2020)

Project: **Monument Ridge East**

Pipe ID: **PIPE 39**

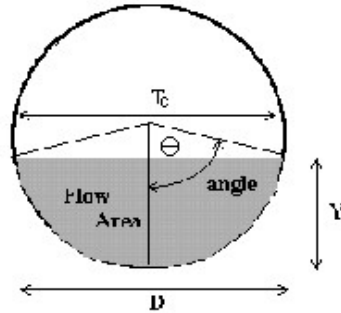

<u>Design Information (Input)</u>	
Pipe Invert Slope	So = 0.0050 ft/ft
Pipe Manning's n-value	n = 0.0130
Pipe Diameter	D = 18.00 inches
Design discharge	Q = 5.40 cfs
<u>Full-Flow Capacity (Calculated)</u>	
Full-flow area	Af = 1.77 sq ft
Full-flow wetted perimeter	Pf = 4.71 ft
Half Central Angle	Theta = 3.14 radians
Full-flow capacity	Qf = 7.45 cfs
<u>Calculation of Normal Flow Condition</u>	
Half Central Angle ($0 < \Theta < 3.14$)	Theta = 1.84 radians
Flow area	An = 1.18 sq ft
Top width	Tn = 1.45 ft
Wetted perimeter	Pn = 2.75 ft
Flow depth	Yn = 0.95 ft
Flow velocity	Vn = 4.59 fps
Discharge	Qn = 5.40 cfs
Percent of Full Flow	Flow = 72.5% of full flow
Normal Depth Froude Number	Fr _n = 0.90 subcritical
<u>Calculation of Critical Flow Condition</u>	
Half Central Angle ($0 < \Theta_c < 3.14$)	Theta-c = 1.77 radians
Critical flow area	Ac = 1.10 sq ft
Critical top width	Tc = 1.47 ft
Critical flow depth	Yc = 0.90 ft
Critical flow velocity	Vc = 4.91 fps
Critical Depth Froude Number	Fr _c = 1.00

CIRCULAR CONDUIT FLOW (Normal & Critical Depth Computation)

MHFD-Culvert, Version 4.00 (May 2020)

Project: **Monument Ridge East**

Pipe ID: **PIPE 40**

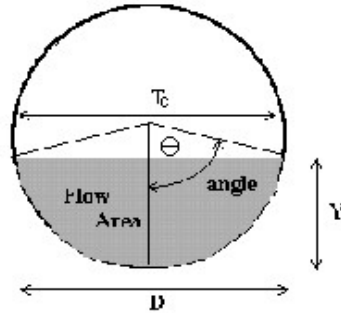

<u>Design Information (Input)</u>	
Pipe Invert Slope	So = 0.0050 ft/ft
Pipe Manning's n-value	n = 0.0130
Pipe Diameter	D = 24.00 inches
Design discharge	Q = 7.50 cfs
<u>Full-Flow Capacity (Calculated)</u>	
Full-flow area	Af = 3.14 sq ft
Full-flow wetted perimeter	Pf = 6.28 ft
Half Central Angle	Theta = 3.14 radians
Full-flow capacity	Qf = 16.04 cfs
<u>Calculation of Normal Flow Condition</u>	
Half Central Angle ($0 < \Theta < 3.14$)	Theta = 1.82 radians
Flow area	An = 2.06 sq ft
Top width	Tn = 1.94 ft
Wetted perimeter	Pn = 3.64 ft
Flow depth	Yn = 1.25 ft
Flow velocity	Vn = 5.54 fps
Discharge	Qn = 11.41 cfs
Percent of Full Flow	Flow = 71.2% of full flow
Normal Depth Froude Number	Fr _n = 0.95 subcritical
<u>Calculation of Critical Flow Condition</u>	
Half Central Angle ($0 < \Theta_c < 3.14$)	Theta-c = 1.75 radians
Critical flow area	Ac = 1.93 sq ft
Critical top width	Tc = 1.97 ft
Critical flow depth	Yc = 1.18 ft
Critical flow velocity	Vc = 3.88 fps
Critical Depth Froude Number	Fr _c = 0.69

CIRCULAR CONDUIT FLOW (Normal & Critical Depth Computation)

MHFD-Culvert, Version 4.00 (May 2020)

Project: **Monument Ridge East**

Pipe ID: **PIPE 41 POND 4 OUT**

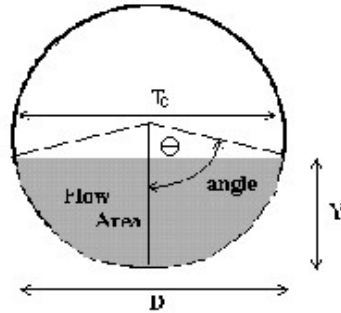

Design Information (Input)	
Pipe Invert Slope	So = 0.0100 ft/ft
Pipe Manning's n-value	n = 0.0130
Pipe Diameter	D = 36.00 inches
Design discharge	Q = 39.40 cfs
Full-Flow Capacity (Calculated)	
Full-flow area	Af = 7.07 sq ft
Full-flow wetted perimeter	Pf = 9.42 ft
Half Central Angle	Theta = 3.14 radians
Full-flow capacity	Qf = 66.88 cfs
Calculation of Normal Flow Condition	
Half Central Angle ($0 < \theta < 3.14$)	Theta = 1.67 radians
Flow area	An = 4.00 sq ft
Top width	Tn = 2.98 ft
Wetted perimeter	Pn = 5.02 ft
Flow depth	Yn = 1.66 ft
Flow velocity	Vn = 9.85 fps
Discharge	Qn = 39.40 cfs
Percent of Full Flow	Flow = 58.9% of full flow
Normal Depth Froude Number	Fr _n = 1.50 supercritical
Calculation of Critical Flow Condition	
Half Central Angle ($0 < \theta_c < 3.14$)	Theta-c = 1.94 radians
Critical flow area	Ac = 5.13 sq ft
Critical top width	Tc = 2.80 ft
Critical flow depth	Yc = 2.04 ft
Critical flow velocity	Vc = 7.68 fps
Critical Depth Froude Number	Fr _c = 1.00

CIRCULAR CONDUIT FLOW (Normal & Critical Depth Computation)

MHFD-Culvert, Version 4.00 (May 2020)

Project: **Monument Ridge East**

Pipe ID: **PIPE42**

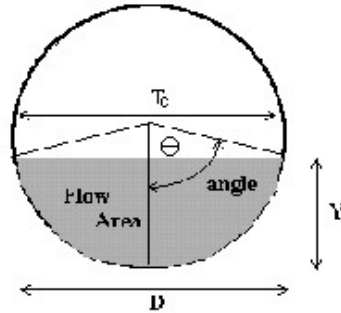

<u>Design Information (Input)</u>	
Pipe Invert Slope	So = 0.0090 ft/ft
Pipe Manning's n-value	n = 0.0130
Pipe Diameter	D = 42.00 inches
Design discharge	Q = 73.30 cfs
<u>Full-Flow Capacity (Calculated)</u>	
Full-flow area	Af = 9.62 sq ft
Full-flow wetted perimeter	Pf = 11.00 ft
Half Central Angle	Theta = 3.14 radians
Full-flow capacity	Qf = 95.70 cfs
<u>Calculation of Normal Flow Condition</u>	
Half Central Angle ($0 < \Theta < 3.14$)	Theta = 1.89 radians
Flow area	An = 6.69 sq ft
Top width	Tn = 3.33 ft
Wetted perimeter	Pn = 6.61 ft
Flow depth	Yn = 2.30 ft
Flow velocity	Vn = 10.96 fps
Discharge	Qn = 73.31 cfs
Percent of Full Flow	Flow = 76.6% of full flow
Normal Depth Froude Number	Fr _n = 1.36 supercritical
<u>Calculation of Critical Flow Condition</u>	
Half Central Angle ($0 < \Theta_c < 3.14$)	Theta-c = 2.13 radians
Critical flow area	Ac = 7.91 sq ft
Critical top width	Tc = 2.96 ft
Critical flow depth	Yc = 2.68 ft
Critical flow velocity	Vc = 9.27 fps
Critical Depth Froude Number	Fr _c = 1.00

CIRCULAR CONDUIT FLOW (Normal & Critical Depth Computation)

MHFD-Culvert, Version 4.00 (May 2020)

Project: Monument Ridge East

Pipe ID: PIPE 43

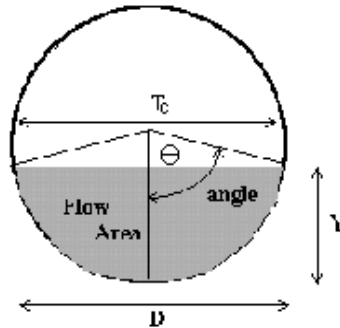

Design Information (Input)	
Pipe Invert Slope	So = 0.0200 ft/ft
Pipe Manning's n-value	n = 0.0130
Pipe Diameter	D = 24.00 inches
Design discharge	Q = 17.40 cfs
Full-Flow Capacity (Calculated)	
Full-flow area	Af = 3.14 sq ft
Full-flow wetted perimeter	Pf = 6.28 ft
Half Central Angle	Theta = 3.14 radians
Full-flow capacity	Qf = 32.08 cfs
Calculation of Normal Flow Condition	
Half Central Angle ($0 < \theta < 3.14$)	Theta = 1.62 radians
Flow area	An = 1.67 sq ft
Top width	Tn = 2.00 ft
Wetted perimeter	Pn = 3.24 ft
Flow depth	Yn = 1.05 ft
Flow velocity	Vn = 10.42 fps
Discharge	Qn = 17.40 cfs
Percent of Full Flow	Flow = 54.2% of full flow
Normal Depth Froude Number	Fr _n = 2.01 supercritical
Calculation of Critical Flow Condition	
Half Central Angle ($0 < \theta_c < 3.14$)	Theta-c = 2.10 radians
Critical flow area	Ac = 2.53 sq ft
Critical top width	Tc = 1.73 ft
Critical flow depth	Yc = 1.50 ft
Critical flow velocity	Vc = 6.87 fps
Critical Depth Froude Number	Fr _c = 1.00

CIRCULAR CONDUIT FLOW (Normal & Critical Depth Computation)

MHFD-Culvert, Version 4.00 (May 2020)

Project: Monument Ridge East

Pipe ID: PIPE 44

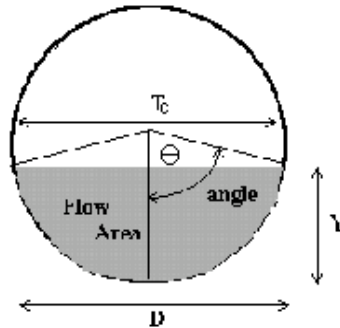

Design Information (Input)	
Pipe Invert Slope	So = 0.0100 ft/ft
Pipe Manning's n-value	n = 0.0130
Pipe Diameter	D = 18.00 inches
Design discharge	Q = 5.50 cfs
Full-Flow Capacity (Calculated)	
Full-flow area	Af = 1.77 sq ft
Full-flow wetted perimeter	Pf = 4.71 ft
Half Central Angle	Theta = 3.14 radians
Full-flow capacity	Qf = 10.53 cfs
Calculation of Normal Flow Condition	
Half Central Angle ($0 < \text{Theta} < 3.14$)	Theta = 1.60 radians
Flow area	An = 0.91 sq ft
Top width	Tn = 1.50 ft
Wetted perimeter	Pn = 2.40 ft
Flow depth	Yn = 0.77 ft
Flow velocity	Vn = 6.02 fps
Discharge	Qn = 5.50 cfs
Percent of Full Flow	Flow = 52.2% of full flow
Normal Depth Froude Number	Fr _n = 1.36 supercritical
Calculation of Critical Flow Condition	
Half Central Angle ($0 < \text{Theta-c} < 3.14$)	Theta-c = 1.78 radians
Critical flow area	Ac = 1.11 sq ft
Critical top width	Tc = 1.47 ft
Critical flow depth	Yc = 0.90 ft
Critical flow velocity	Vc = 4.94 fps
Critical Depth Froude Number	Fr _c = 1.00

CIRCULAR CONDUIT FLOW (Normal & Critical Depth Computation)

MHFD-Culvert, Version 4.00 (May 2020)

Project: Monument Ridge East

Pipe ID: PipeS 45,46 & 47

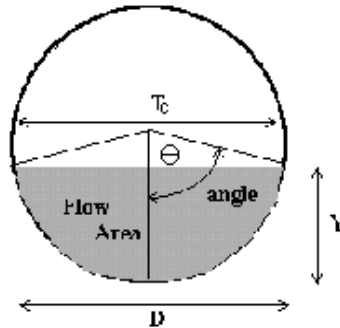

Design Information (Input)	
Pipe Invert Slope	So = 0.0100 ft/ft
Pipe Manning's n-value	n = 0.0130
Pipe Diameter	D = 54.00 inches
Design discharge	Q = 108.30 cfs
Full-Flow Capacity (Calculated)	
Full-flow area	Af = 15.90 sq ft
Full-flow wetted perimeter	Pf = 14.14 ft
Half Central Angle	Theta = 3.14 radians
Full-flow capacity	Qf = 197.18 cfs
Calculation of Normal Flow Condition	
Half Central Angle ($0 < \text{Theta} < 3.14$)	Theta = 1.63 radians
Flow area	An = 8.54 sq ft
Top width	Tn = 4.49 ft
Wetted perimeter	Pn = 7.33 ft
Flow depth	Yn = 2.38 ft
Flow velocity	Vn = 12.69 fps
Discharge	Qn = 108.30 cfs
Percent of Full Flow	Flow = 54.9% of full flow
Normal Depth Froude Number	Fr _n = 1.62 supercritical
Calculation of Critical Flow Condition	
Half Central Angle ($0 < \text{Theta-c} < 3.14$)	Theta-c = 1.94 radians
Critical flow area	Ac = 11.52 sq ft
Critical top width	Tc = 4.20 ft
Critical flow depth	Yc = 3.06 ft
Critical flow velocity	Vc = 9.40 fps
Critical Depth Froude Number	Fr _c = 1.00

CIRCULAR CONDUIT FLOW (Normal & Critical Depth Computation)

MHFD-Culvert, Version 4.00 (May 2020)

Project: Monument Ridge East

Pipe ID: PipeS 48 AND 49

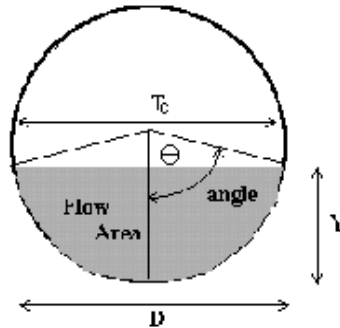

Design Information (Input)	
Pipe Invert Slope	So = 0.0075 ft/ft
Pipe Manning's n-value	n = 0.0130
Pipe Diameter	D = 78.00 inches
Design discharge	Q = 322.30 cfs
Full-Flow Capacity (Calculated)	
Full-flow area	Af = 33.18 sq ft
Full-flow wetted perimeter	Pf = 20.42 ft
Half Central Angle	Theta = 3.14 radians
Full-flow capacity	Qf = 455.26 cfs
Calculation of Normal Flow Condition	
Half Central Angle ($0 < \text{Theta} < 3.14$)	Theta = 1.82 radians
Flow area	An = 21.66 sq ft
Top width	Tn = 6.31 ft
Wetted perimeter	Pn = 11.80 ft
Flow depth	Yn = 4.04 ft
Flow velocity	Vn = 14.88 fps
Discharge	Qn = 322.31 cfs
Percent of Full Flow	Flow = 70.8% of full flow
Normal Depth Froude Number	Fr _n = 1.41 supercritical
Calculation of Critical Flow Condition	
Half Central Angle ($0 < \text{Theta-c} < 3.14$)	Theta-c = 2.07 radians
Critical flow area	Ac = 26.38 sq ft
Critical top width	Tc = 5.69 ft
Critical flow depth	Yc = 4.82 ft
Critical flow velocity	Vc = 12.22 fps
Critical Depth Froude Number	Fr _c = 1.00

DETENTION BASIN STAGE-STORAGE TABLE BUILDER

MHFD-Detention, Version 4.04 (February 2021)

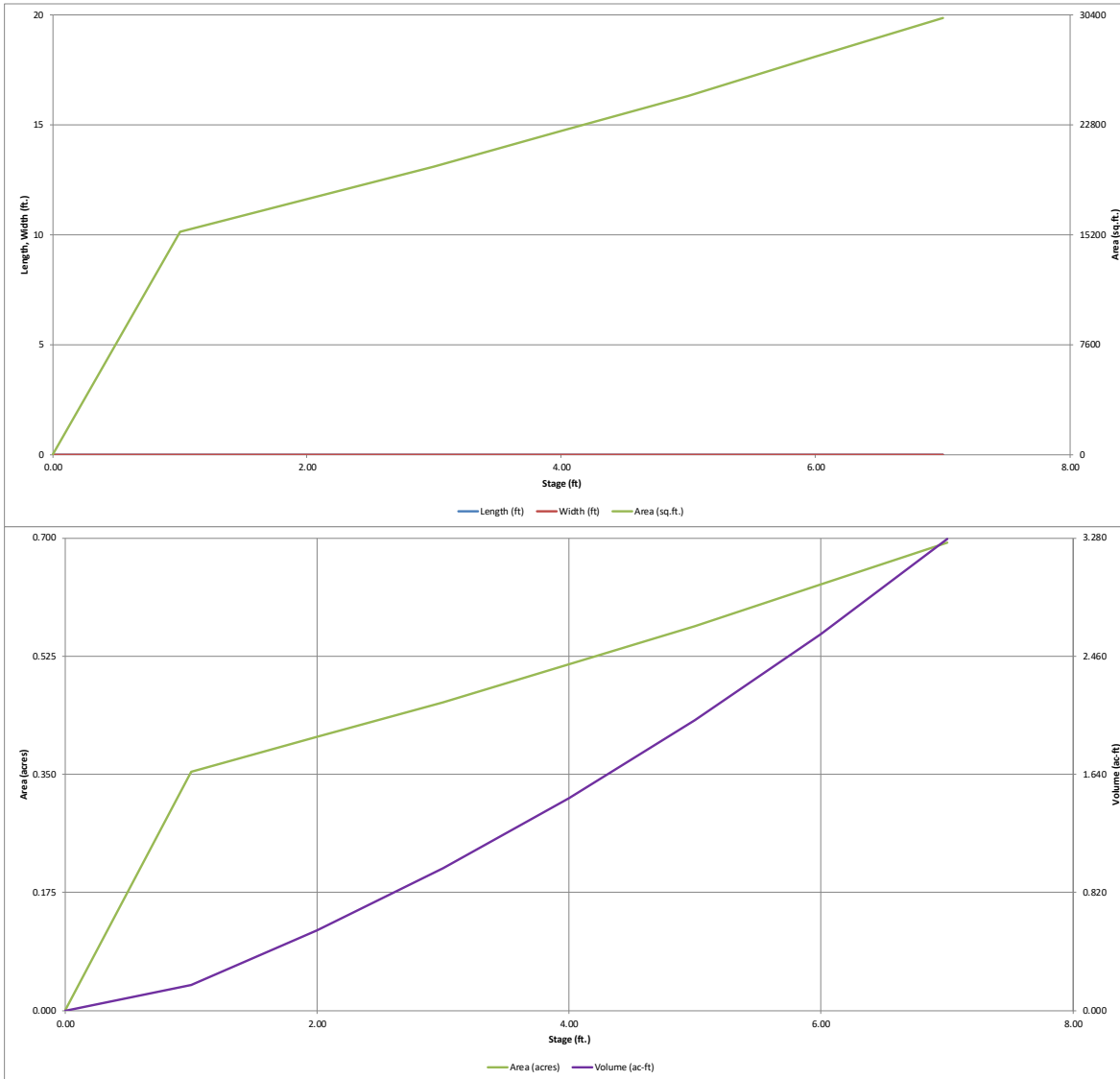

DETENTION BASIN OUTLET STRUCTURE DESIGN

MHFD-Detention, Version 4.04 (February 2021)

Project: Monument Ridge East
Basin ID: Pond 1 Qmax out = 90% PreDev Q. Q10=12.9cfs, Q100=35.5cfs

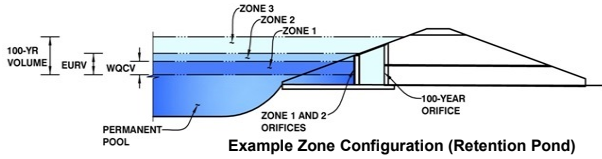

	Estimated Stage (ft)	Estimated Volume (ac-ft)	Outlet Type
Zone 1	#N/A		
Zone 2			
Zone 3			
Total (all zones)			

User Input: Orifice at Underdrain Outlet (typically used to drain WOCV in a Filtration BMP)

Underdrain Orifice Invert Depth = ft (distance below the filtration media surface)

Underdrain Orifice Diameter = inches

Calculated Parameters for Underdrain

Underdrain Orifice Area = ft²

Underdrain Orifice Centroid = feet

User Input: Orifice Plate with one or more orifices or Elliptical Slot Weir (typically used to drain WOCV and/or EURV in a sedimentation BMP)

Invert of Lowest Orifice = ft (relative to basin bottom at Stage = 0 ft)

Depth at top of Zone using Orifice Plate = ft (relative to basin bottom at Stage = 0 ft)

Orifice Plate: Orifice Vertical Spacing = inches

Orifice Plate: Orifice Area per Row = inches

Calculated Parameters for Plate

WQ Orifice Area per Row = ft²

Elliptical Half-Width = feet

Elliptical Slot Centroid = feet

Elliptical Slot Area = ft²

User Input: Stage and Total Area of Each Orifice Row (numbered from lowest to highest)

	Row 1 (optional)	Row 2 (optional)	Row 3 (optional)	Row 4 (optional)	Row 5 (optional)	Row 6 (optional)	Row 7 (optional)	Row 8 (optional)
Stage of Orifice Centroid (ft)	<input type="text"/>	<input type="text"/>	<input type="text"/>	<input type="text"/>	<input type="text"/>	<input type="text"/>	<input type="text"/>	<input type="text"/>
Orifice Area (sq. inches)	<input type="text"/>	<input type="text"/>	<input type="text"/>	<input type="text"/>	<input type="text"/>	<input type="text"/>	<input type="text"/>	<input type="text"/>

	Row 9 (optional)	Row 10 (optional)	Row 11 (optional)	Row 12 (optional)	Row 13 (optional)	Row 14 (optional)	Row 15 (optional)	Row 16 (optional)
Stage of Orifice Centroid (ft)	<input type="text"/>	<input type="text"/>	<input type="text"/>	<input type="text"/>	<input type="text"/>	<input type="text"/>	<input type="text"/>	<input type="text"/>
Orifice Area (sq. inches)	<input type="text"/>	<input type="text"/>	<input type="text"/>	<input type="text"/>	<input type="text"/>	<input type="text"/>	<input type="text"/>	<input type="text"/>

User Input: Vertical Orifice (Circular or Rectangular)

	Not Selected	Not Selected
Invert of Vertical Orifice =	<input type="text"/>	<input type="text"/>
Depth at top of Zone using Vertical Orifice =	<input type="text"/>	<input type="text"/>
Vertical Orifice Diameter =	<input type="text"/>	<input type="text"/>

Calculated Parameters for Vertical Orif

	Not Selected	Not Selected
Vertical Orifice Area =	<input type="text"/>	<input type="text"/>
Vertical Orifice Centroid =	<input type="text"/>	<input type="text"/>

User Input: Overflow Weir (Dropbox with Flat or Sloped Grate and Outlet Pipe OR Rectangular/Trapezoidal Weir (and No Outlet Pipe))

	Not Selected	Not Selected
Overflow Weir Front Edge Height, Ho =	<input type="text"/>	<input type="text"/>
Overflow Weir Front Edge Length =	<input type="text"/>	<input type="text"/>
Overflow Weir Grate Slope =	<input type="text"/>	<input type="text"/>
Horiz. Length of Weir Sides =	<input type="text"/>	<input type="text"/>
Overflow Grate Type =	<input type="text"/>	<input type="text"/>
Debris Clogging % =	<input type="text"/>	<input type="text"/>

Calculated Parameters for Overflow Weir

	Not Selected	Not Selected
Height of Grate Upper Edge, H ₁ =	<input type="text"/>	<input type="text"/>
Overflow Weir Slope Length =	<input type="text"/>	<input type="text"/>
Grate Open Area / 100-yr Orifice Area =	<input type="text"/>	<input type="text"/>
Overflow Grate Open Area w/o Debris =	<input type="text"/>	<input type="text"/>
Overflow Grate Open Area w/ Debris =	<input type="text"/>	<input type="text"/>

User Input: Outlet Pipe w/ Flow Restriction Plate (Circular Orifice, Restrictor Plate, or Rectangular Orifice)

	Not Selected	Not Selected
Depth to Invert of Outlet Pipe =	<input type="text"/>	<input type="text"/>
Circular Orifice Diameter =	<input type="text"/>	<input type="text"/>

Calculated Parameters for Outlet Pipe w/ Flow Restriction Plate

	Not Selected	Not Selected
Outlet Orifice Area =	<input type="text"/>	<input type="text"/>
Outlet Orifice Centroid =	<input type="text"/>	<input type="text"/>
Half-Central Angle of Restrictor Plate on Pipe =	<input type="text"/>	<input type="text"/>

User Input: Emergency Spillway (Rectangular or Trapezoidal)

Spillway Invert Stage =	<input type="text"/>	ft (relative to basin bottom at Stage = 0 ft)
Spillway Crest Length =	<input type="text"/>	feet
Spillway End Slopes =	<input type="text"/>	H:V
Freeboard above Max Water Surface =	<input type="text"/>	feet

Calculated Parameters for Spillway

Spillway Design Flow Depth =	<input type="text"/>	feet
Stage at Top of Freeboard =	<input type="text"/>	feet
Basin Area at Top of Freeboard =	<input type="text"/>	acres
Basin Volume at Top of Freeboard =	<input type="text"/>	acre-ft

Routed Hydrograph Results

The user can override the default CUHP hydrographs and runoff volumes by entering new values in the Inflow Hydrographs table (Columns W through AF)

	WQCV	EURV	2 Year	5 Year	10 Year	25 Year	50 Year	100 Year
Design Storm Return Period	N/A	N/A	1.19	1.50	1.75	2.00	2.25	2.52
One-Hour Rainfall Depth (in)	N/A	N/A	1.19	1.50	1.75	2.00	2.25	2.52
CUHP Runoff Volume (acre-ft)	0.397	1.187	1.114	1.619	2.067	2.688	3.183	3.817
Inflow Hydrograph Volume (acre-ft)	N/A	N/A	1.114	1.619	2.067	2.688	3.183	3.817
CUHP Predevelopment Peak Q (cfs)	N/A	N/A	3.4	9.5	14.3	25.2	31.5	39.4
OPTIONAL Override Predevelopment Peak Q (cfs)	N/A	N/A						
Predevelopment Unit Peak Flow, q (cfs/acre)	N/A	N/A	0.14	0.39	0.58	1.03	1.29	1.61
Peak Inflow Q (cfs)	N/A	N/A	20.8	31.0	38.3	50.6	59.8	71.9
Peak Outflow Q (cfs)								
Ratio Peak Outflow to Predevelopment Q								
Structure Controlling Flow								
Max Velocity through Gate 1 (fps)								
Max Velocity through Gate 2 (fps)								
Time to Drain 97% of Inflow Volume (hours)								
Time to Drain 99% of Inflow Volume (hours)								
Maximum Ponding Depth (ft)								
Area at Maximum Ponding Depth (acres)								
Maximum Volume Stored (acre-ft)								

Unresolved: provide all preliminary design data

DETENTION BASIN OUTLET STRUCTURE DESIGN

MHFD-Detention, Version 4.04 (February 2021)

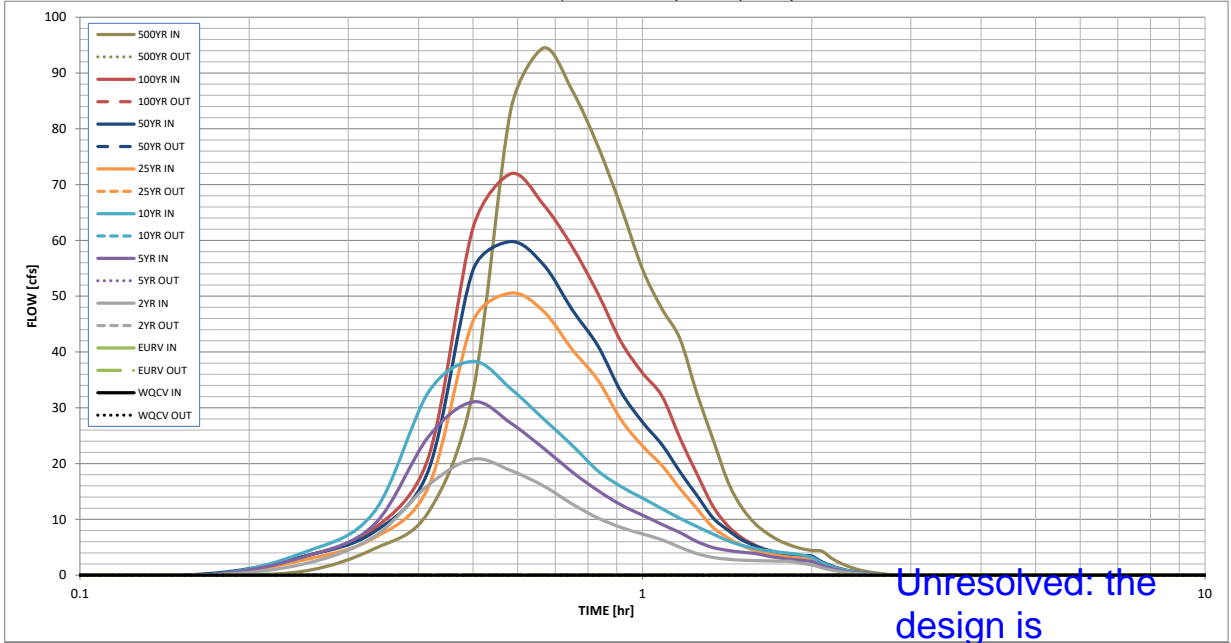

Unresolved: the design is incomplete, maxing out

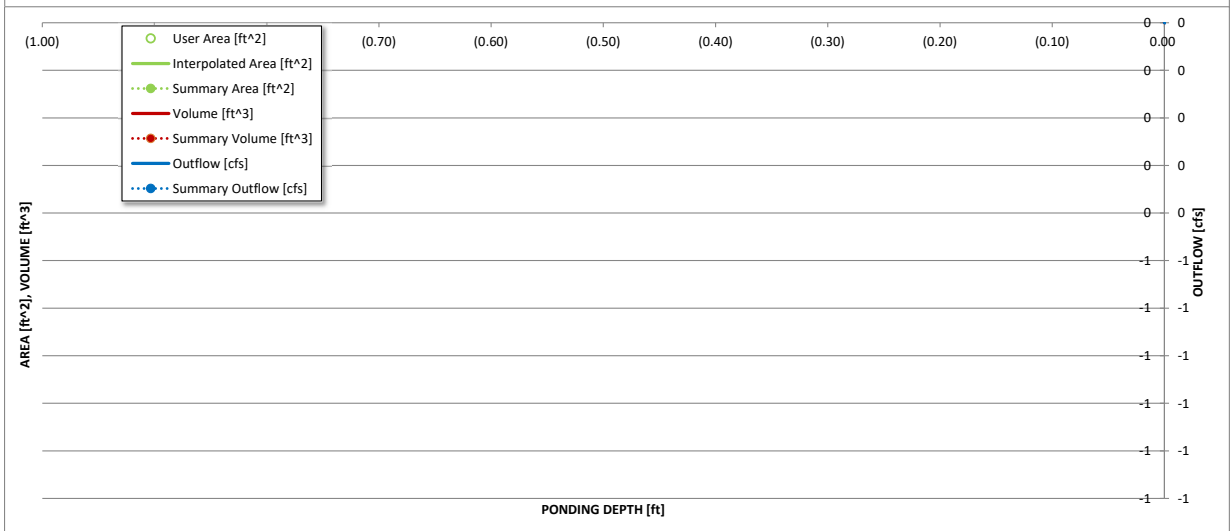
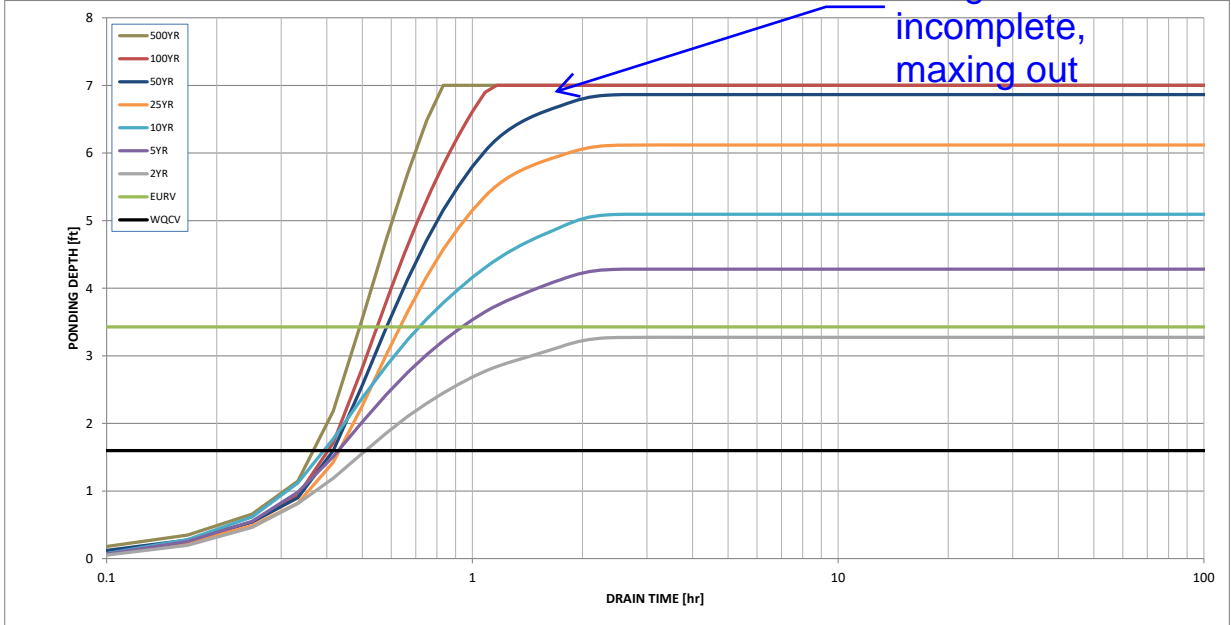

S-A-V-D Chart Axis Override	X-axis	Left Y-Axis	Right Y-Axis
minimum bound			
maximum bound			

DETENTION BASIN STAGE-STORAGE TABLE BUILDER

MHFD- Detention, Version 4.04 (February 2021)

Project: Monument Ridge East

Basin ID: Pond 2 Qmax out = 90% PreDev Q. Q10=10.6cfs, Q100=28.3cfs

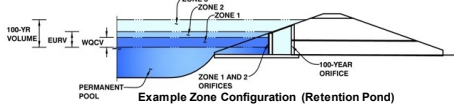

Watershed Information

Selected BMP Type =	EDB	
Watershed Area =	20.48	acres
Watershed Length =	1,370	ft
Watershed Length to Centroid =	660	ft
Watershed Slope =	0.049	ft/ft
Watershed Imperviousness =	57.88%	percent
Percentage Hydrologic Soil Group A =	0.0%	percent
Percentage Hydrologic Soil Group B =	82.0%	percent
Percentage Hydrologic Soil Groups C/D =	18.0%	percent
Target WQCV Drain Time =	40.0	hours
Location for 1-hr Rainfall Depths =	User Input	

After providing required inputs above including 1-hour rainfall depths, click 'Run CUHP' to generate runoff hydrographs using the embedded Colorado Urban Hydrograph Procedure.

Water Quality Capture Volume (WQCV) =	0.391	acre-feet
Excess Urban Runoff Volume (EURV) =	1.256	acre-feet
2-yr Runoff Volume (P1 = 1.19 in.) =	1.170	acre-feet
5-yr Runoff Volume (P1 = 1.5 in.) =	1.625	acre-feet
10-yr Runoff Volume (P1 = 1.75 in.) =	2.024	acre-feet
25-yr Runoff Volume (P1 = 2 in.) =	2.517	acre-feet
50-yr Runoff Volume (P1 = 2.25 in.) =	2.938	acre-feet
100-yr Runoff Volume (P1 = 2.52 in.) =	3.456	acre-feet
500-yr Runoff Volume (P1 = 3.14 in.) =	4.533	acre-feet
Approximate 2-yr Detention Volume =	0.987	acre-feet
Approximate 5-yr Detention Volume =	1.353	acre-feet
Approximate 10-yr Detention Volume =	1.713	acre-feet
Approximate 25-yr Detention Volume =	1.853	acre-feet
Approximate 50-yr Detention Volume =	1.929	acre-feet
Approximate 100-yr Detention Volume =	2.120	acre-feet

Optional User Overrides

		acre-feet
		acre-feet
	1.19	inches
	1.50	inches
	1.75	inches
	2.00	inches
	2.25	inches
	2.52	inches
		inches

Define Zones and Basin Geometry

Select Zone 1 Storage Volume (Required) =		acre-feet
Select Zone 2 Storage Volume (Optional) =		acre-feet
Select Zone 3 Storage Volume (Optional) =		acre-feet
Total Detention Basin Volume =		acre-feet
Initial Surcharge Volume (ISV) =	user	ft ³
Initial Surcharge Depth (ISD) =	user	ft
Total Available Detention Depth (H _{total}) =	user	ft
Depth of Trickle Channel (H _{tc}) =	user	ft
Slope of Trickle Channel (S _{tc}) =	user	ft/ft
Slopes of Main Basin Sides (S _{main}) =	user	H:V
Basin Length-to-Width Ratio (R _{L/W}) =	user	
Initial Surcharge Area (A _{ISV}) =	user	ft ²
Surcharge Volume Length (L _{ISV}) =	user	ft
Surcharge Volume Width (W _{ISV}) =	user	ft
Depth of Basin Floor (H _{L,00R}) =	user	ft
Length of Basin Floor (L _{L,00R}) =	user	ft
Width of Basin Floor (W _{L,00R}) =	user	ft
Area of Basin Floor (A _{L,00R}) =	user	ft ²
Volume of Basin Floor (V _{L,00R}) =	user	ft ³
Depth of Main Basin (H _{MAIN}) =	user	ft
Length of Main Basin (L _{MAIN}) =	user	ft
Width of Main Basin (W _{MAIN}) =	user	ft
Area of Main Basin (A _{MAIN}) =	user	ft ²
Volume of Main Basin (V _{MAIN}) =	user	ft ³
Calculated Total Basin Volume (V _{total}) =	user	acre-feet

Stage - Storage Description	Stage (ft)	Optional Override Stage (ft)	Length (ft)	Width (ft)	Area (ft ²)	Optional Override Area (ft ²)	Area (acre)	Volume (ft ³)	Volume (ac-ft)
Top of Micropool	--	0.00	--	--	5,400		0.124		
7278	--	1.00	--	--	7,600		0.174	6,500	0.149
7280	--	3.00	--	--	12,000		0.275	26,100	0.599
7282	--	5.00	--	--	16,300		0.374	54,400	1.249
7284	--	7.00	--	--	21,550		0.495	92,250	2.118
7286	--	9.00	--	--	27,500		0.631	141,300	3.244

DETENTION BASIN STAGE-STORAGE TABLE BUILDER

MHFD-Detention, Version 4.04 (February 2021)

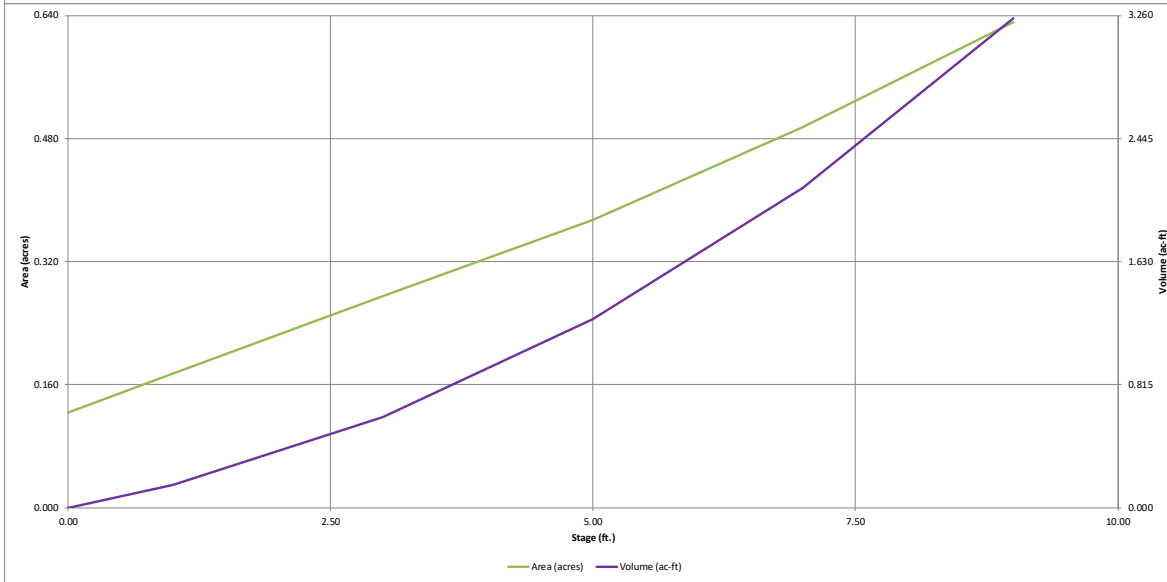
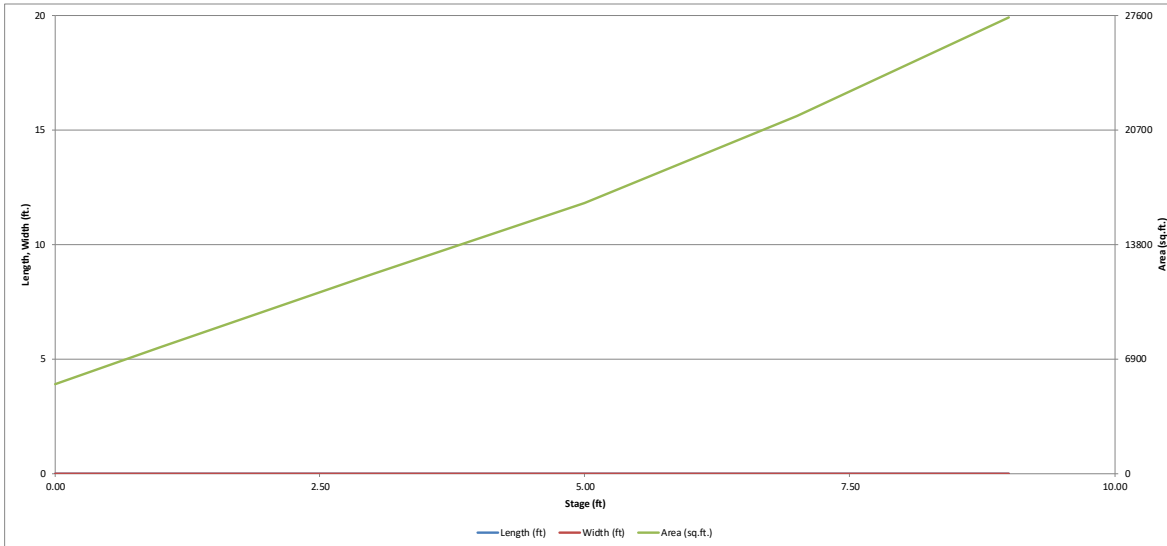

DETENTION BASIN OUTLET STRUCTURE DESIGN

MHFD-Detention, Version 4.04 (February 2021)

Project: Monument Ridge East
Basin ID: Pond 2 Qmax out = 90% PreDev Q. Q10=10.6cfs, Q100=28.3cfs

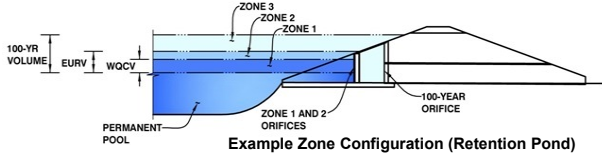

	Estimated Stage (ft)	Estimated Volume (ac-ft)	Outlet Type
Zone 1	#N/A		
Zone 2			
Zone 3			
Total (all zones)			

User Input: Orifice at Underdrain Outlet (typically used to drain WOCV in a Filtration BMP)

Underdrain Orifice Invert Depth = ft (distance below the filtration media surface) Underdrain Orifice Area = ft²
 Underdrain Orifice Diameter = inches Underdrain Orifice Centroid = feet

User Input: Orifice Plate with one or more orifices or Elliptical Slot Weir (typically used to drain WOCV and/or EURV in a sedimentation BMP)

Invert of Lowest Orifice = ft (relative to basin bottom at Stage = 0 ft) WQ Orifice Area per Row = ft²
 Depth at top of Zone using Orifice Plate = ft (relative to basin bottom at Stage = 0 ft) Elliptical Half-Width = feet
 Orifice Plate: Orifice Vertical Spacing = inches Elliptical Slot Centroid = feet
 Orifice Plate: Orifice Area per Row = inches Elliptical Slot Area = ft²

User Input: Stage and Total Area of Each Orifice Row (numbered from lowest to highest)

	Row 1 (optional)	Row 2 (optional)	Row 3 (optional)	Row 4 (optional)	Row 5 (optional)	Row 6 (optional)	Row 7 (optional)	Row 8 (optional)
Stage of Orifice Centroid (ft)	<input type="text"/>	<input type="text"/>	<input type="text"/>	<input type="text"/>	<input type="text"/>	<input type="text"/>	<input type="text"/>	<input type="text"/>
Orifice Area (sq. inches)	<input type="text"/>	<input type="text"/>	<input type="text"/>	<input type="text"/>	<input type="text"/>	<input type="text"/>	<input type="text"/>	<input type="text"/>

	Row 9 (optional)	Row 10 (optional)	Row 11 (optional)	Row 12 (optional)	Row 13 (optional)	Row 14 (optional)	Row 15 (optional)	Row 16 (optional)
Stage of Orifice Centroid (ft)	<input type="text"/>	<input type="text"/>	<input type="text"/>	<input type="text"/>	<input type="text"/>	<input type="text"/>	<input type="text"/>	<input type="text"/>
Orifice Area (sq. inches)	<input type="text"/>	<input type="text"/>	<input type="text"/>	<input type="text"/>	<input type="text"/>	<input type="text"/>	<input type="text"/>	<input type="text"/>

User Input: Vertical Orifice (Circular or Rectangular)

	Not Selected	Not Selected		Not Selected	Not Selected
Invert of Vertical Orifice =	<input type="checkbox"/>	<input type="checkbox"/>	<input type="text"/> ft (relative to basin bottom at Stage = 0 ft)	Vertical Orifice Area =	<input type="text"/> ft ²
Depth at top of Zone using Vertical Orifice =	<input type="checkbox"/>	<input type="checkbox"/>	<input type="text"/> ft (relative to basin bottom at Stage = 0 ft)	Vertical Orifice Centroid =	<input type="text"/> feet
Vertical Orifice Diameter =	<input type="checkbox"/>	<input type="checkbox"/>	<input type="text"/> inches		

User Input: Overflow Weir (Dropbox with Flat or Sloped Grate and Outlet Pipe OR Rectangular/Trapezoidal Weir (and No Outlet Pipe))

	Not Selected	Not Selected		Not Selected	Not Selected
Overflow Weir Front Edge Height, Ho =	<input type="checkbox"/>	<input type="checkbox"/>	<input type="text"/> ft (relative to basin bottom at Stage = 0 ft)	Height of Grate Upper Edge, H ₁ =	<input type="text"/> feet
Overflow Weir Front Edge Length =	<input type="checkbox"/>	<input type="checkbox"/>	<input type="text"/> feet	Overflow Weir Slope Length =	<input type="text"/> feet
Overflow Weir Grate Slope =	<input type="checkbox"/>	<input type="checkbox"/>	<input type="text"/> H:V	Grate Open Area / 100-yr Orifice Area =	<input type="text"/>
Horiz. Length of Weir Sides =	<input type="checkbox"/>	<input type="checkbox"/>	<input type="text"/> feet	Overflow Grate Open Area w/o Debris =	<input type="text"/> ac-ft
Overflow Grate Type =	<input type="checkbox"/>	<input type="checkbox"/>		Overflow Grate Open Area w/ Debris =	<input type="text"/> ac-ft
Debris Clogging % =	<input type="checkbox"/>	<input type="checkbox"/>	<input type="text"/> %		

User Input: Outlet Pipe w/ Flow Restriction Plate (Circular Orifice, Restrictor Plate, or Rectangular Orifice)

	Not Selected	Not Selected		Not Selected	Not Selected
Depth to Invert of Outlet Pipe =	<input type="checkbox"/>	<input type="checkbox"/>	<input type="text"/> ft (distance below basin bottom at Stage = 0 ft)	Outlet Orifice Area =	<input type="text"/> ft ²
Circular Orifice Diameter =	<input type="checkbox"/>	<input type="checkbox"/>	<input type="text"/> inches	Outlet Orifice Centroid =	<input type="text"/> feet
				Half-Central Angle of Restrictor Plate on Pipe =	<input type="text"/> degrees

User Input: Emergency Spillway (Rectangular or Trapezoidal)

Spillway Invert Stage =	<input type="text"/>	ft (relative to basin bottom at Stage = 0 ft)	Spillway Design Flow Depth =	<input type="text"/>	feet
Spillway Crest Length =	<input type="text"/>	feet	Stage at Top of Freeboard =	<input type="text"/>	feet
Spillway End Slopes =	<input type="text"/>	H:V	Basin Area at Top of Freeboard =	<input type="text"/>	acres
Freeboard above Max Water Surface =	<input type="text"/>	feet	Basin Volume at Top of Freeboard =	<input type="text"/>	acre-ft

Routed Hydrograph Results *The user can override the default CUHP hydrographs and runoff volumes by entering new values in the Inflow Hydrographs table (Columns W through AF)*

	WQCV	EURV	2 Year	5 Year	10 Year	25 Year	50 Year	100 Year
Design Storm Return Period	N/A	N/A						
One-Hour Rainfall Depth (in)	N/A	N/A	1.19	1.50	1.75	2.00	2.25	2.52
CUHP Runoff Volume (acre-ft)	0.391	1.256	1.170	1.625	2.024	2.517	2.938	3.456
Inflow Hydrograph Volume (acre-ft)	N/A	N/A	1.170	1.625	2.024	2.517	2.938	3.456
CUHP Predevelopment Peak Q (cfs)	N/A	N/A	3.1	7.8	11.8	20.2	25.2	31.4
OPTIONAL Override Predevelopment Peak Q (cfs)	N/A	N/A						
Predevelopment Unit Peak Flow, q (cfs/acre)	N/A	N/A	0.15	0.38	0.58	0.99	1.23	1.53
Peak Inflow Q (cfs)	N/A	N/A	22.5	31.4	37.9	47.9	55.8	66.6
Peak Outflow Q (cfs)								
Ratio Peak Outflow to Predevelopment Q								
Structure Controlling Flow								
Max Velocity through Gate 1 (fps)								
Max Velocity through Gate 2 (fps)								
Time to Drain 97% of Inflow Volume (hours)								
Time to Drain 99% of Inflow Volume (hours)								
Maximum Ponding Depth (ft)								
Area at Maximum Ponding Depth (acres)								
Maximum Volume Stored (acre-ft)								

Unresolved: provide all preliminary design data

DETENTION BASIN OUTLET STRUCTURE DESIGN

MHFD-Detention, Version 4.04 (February 2021)

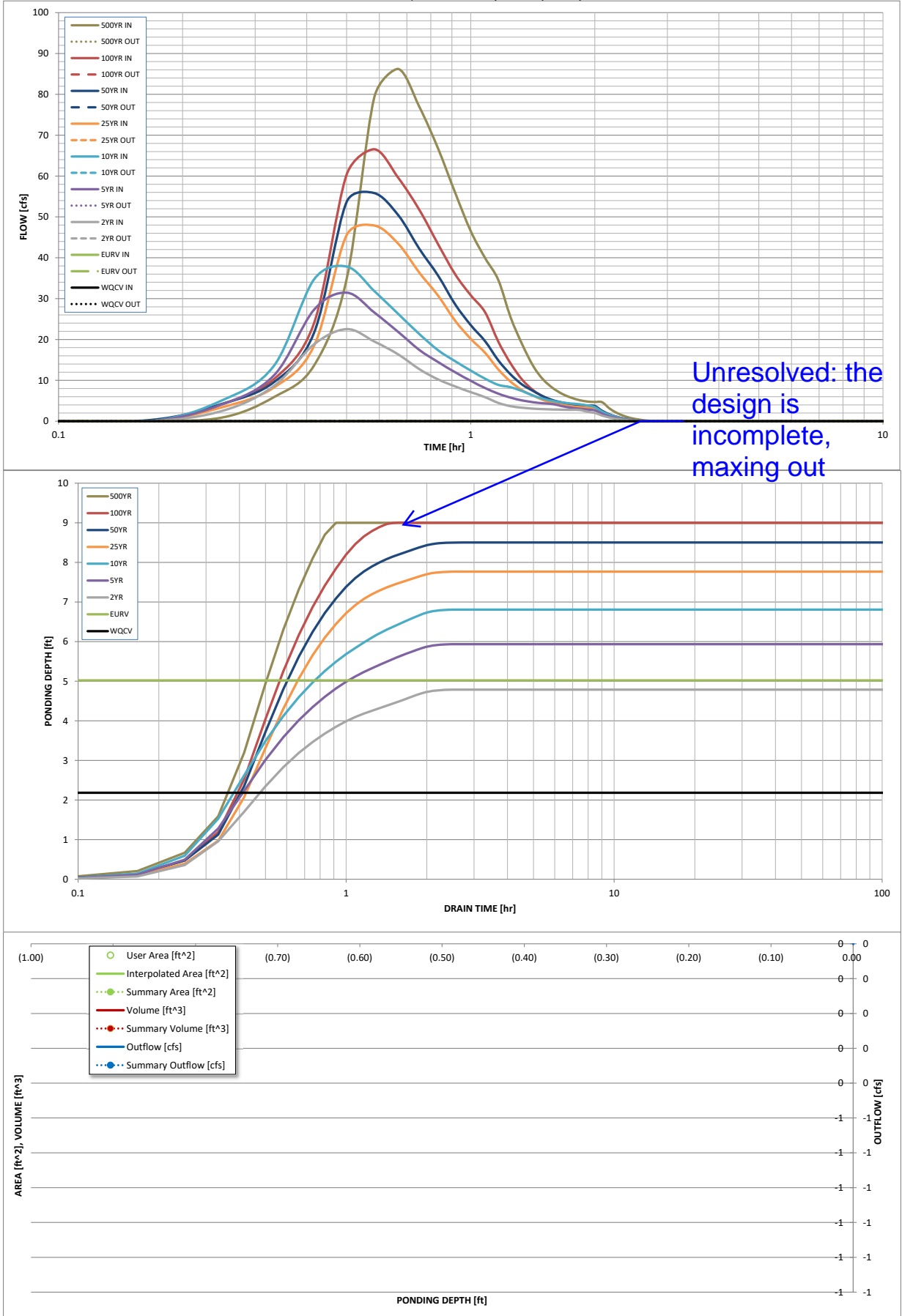

S-A-V-D Chart Axis Override	X-axis	Left Y-Axis	Right Y-Axis
minimum bound			
maximum bound			

DETENTION BASIN OUTLET STRUCTURE DESIGN

MHFD-Detention, Version 4.04 (February 2021)

Project: Monument Ridge East

Basin ID: Pond 3 Qmax out = 90% PreDev Q, Q10=2.1cfs, Q100=5.6cfs

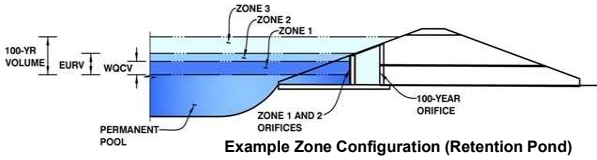

	Estimated Stage (ft)	Estimated Volume (ac-ft)	Outlet Type
Zone 1	#N/A		
Zone 2			
Zone 3			
Total (all zones)			

User Input: Orifice at Underdrain Outlet (typically used to drain WQCV in a Filtration BMP)

Underdrain Orifice Invert Depth = ft (distance below the filtration media surface)
 Underdrain Orifice Diameter = inches

Underdrain Orifice Area = ft²
 Underdrain Orifice Centroid = feet

User Input: Orifice Plate with one or more orifices or Elliptical Slot Weir (typically used to drain WQCV and/or EURV in a sedimentation BMP)

Invert of Lowest Orifice = ft (relative to basin bottom at Stage = 0 ft)
 Depth at top of Zone using Orifice Plate = ft (relative to basin bottom at Stage = 0 ft)
 Orifice Plate: Orifice Vertical Spacing = inches
 Orifice Plate: Orifice Area per Row = inches

Calculated Parameters for Plate
 WQ Orifice Area per Row = ft²
 Elliptical Half-Width = feet
 Elliptical Slot Centroid = feet
 Elliptical Slot Area = ft²

User Input: Stage and Total Area of Each Orifice Row (numbered from lowest to highest)

	Row 1 (optional)	Row 2 (optional)	Row 3 (optional)	Row 4 (optional)	Row 5 (optional)	Row 6 (optional)	Row 7 (optional)	Row 8 (optional)
Stage of Orifice Centroid (ft)	<input type="text"/>	<input type="text"/>	<input type="text"/>	<input type="text"/>	<input type="text"/>	<input type="text"/>	<input type="text"/>	<input type="text"/>
Orifice Area (sq. inches)	<input type="text"/>	<input type="text"/>	<input type="text"/>	<input type="text"/>	<input type="text"/>	<input type="text"/>	<input type="text"/>	<input type="text"/>
	Row 9 (optional)	Row 10 (optional)	Row 11 (optional)	Row 12 (optional)	Row 13 (optional)	Row 14 (optional)	Row 15 (optional)	Row 16 (optional)
Stage of Orifice Centroid (ft)	<input type="text"/>	<input type="text"/>	<input type="text"/>	<input type="text"/>	<input type="text"/>	<input type="text"/>	<input type="text"/>	<input type="text"/>
Orifice Area (sq. inches)	<input type="text"/>	<input type="text"/>	<input type="text"/>	<input type="text"/>	<input type="text"/>	<input type="text"/>	<input type="text"/>	<input type="text"/>

User Input: Vertical Orifice (Circular or Rectangular)

Invert of Vertical Orifice = ft (relative to basin bottom at Stage = 0 ft)
 Depth at top of Zone using Vertical Orifice = ft (relative to basin bottom at Stage = 0 ft)
 Vertical Orifice Diameter = inches

Calculated Parameters for Vertical Orifice
 Vertical Orifice Area = ft²
 Vertical Orifice Centroid = feet

User Input: Overflow Weir (Dropbox with Flat or Sloped Gate and Outlet Pipe OR Rectangular/Trapezoidal Weir (and No Outlet Pipe))

Overflow Weir Front Edge Height, Ho = ft (relative to basin bottom at Stage = 0 ft)
 Overflow Weir Front Edge Length = feet
 Overflow Weir Gate Slope = H:V
 Horiz. Length of Weir Sides = feet
 Overflow Gate Type =
 Debris Clogging % = %

Calculated Parameters for Overflow Weir
 Height of Gate Upper Edge, H_g = feet
 Overflow Weir Slope Length = feet
 Gate Open Area / 100-yr Orifice Area =
 Overflow Gate Open Area w/o Debris = ft²
 Overflow Gate Open Area w/ Debris = ft²

User Input: Outlet Pipe w/ Flow Restriction Plate (Circular Orifice, Restrictor Plate, or Rectangular Orifice)

Depth to Invert of Outlet Pipe = ft (distance below basin bottom at Stage = 0 ft)
 Circular Orifice Diameter = inches

Calculated Parameters for Outlet Pipe w/ Flow Restriction Plate
 Outlet Orifice Area = ft²
 Outlet Orifice Centroid = feet
 Half-Central Angle of Restrictor Plate on Pipe = radians

User Input: Emergency Spillway (Rectangular or Trapezoidal)

Spillway Invert Stage = ft (relative to basin bottom at Stage = 0 ft)
 Spillway Crest Length = feet
 Spillway End Slopes = H:V
 Freeboard above Max Water Surface = feet

Calculated Parameters for Spillway
 Spillway Design Flow Depth = feet
 Stage at Top of Freeboard = feet
 Basin Area at Top of Freeboard = acres
 Basin Volume at Top of Freeboard = acre-ft

Routed Hydrograph Results

The user can override the default CUHP hydrographs and runoff volumes by entering new values in the Inflow Hydrographs table (Columns W through AF).

	WQCV	EURV	2 Year	5 Year	10 Year	25 Year	50 Year	100 Year	500 Year
Design Storm Return Period	N/A	N/A	1.19	1.50	1.76	2.00	2.25	2.52	3.14
One-Hour Rainfall Depth (in)	0.106	0.326	0.327	0.456	0.569	0.704	0.822	0.966	1.268
CUHP Runoff Volume (acre-ft)	N/A	N/A	0.327	0.456	0.569	0.704	0.822	0.966	1.268
Inflow Hydrograph Volume (acre-ft)	N/A	N/A	0.7	1.6	2.3	3.9	4.9	6.2	8.6
CUHP Predevelopment Peak Q (cfs)	N/A	N/A							
OPTIONAL Override Predevelopment Peak Q (cfs)	N/A	N/A							
Predevelopment Unit Peak Flow, q (cfs/acre)	N/A	N/A	0.12	0.28	0.42	0.70	0.87	1.10	1.54
Peak Inflow Q (cfs)	N/A	N/A	4.6	6.4	7.8	10.0	11.6	13.7	17.9
Peak Outflow Q (cfs)									
Ratio Peak Outflow to Predevelopment Q									
Structure Controlling Flow									
Max Velocity through Gate 1 (fps)									
Max Velocity through Gate 2 (fps)									
Time to Drain 97% of Inflow Volume (hours)									
Time to Drain 99% of Inflow Volume (hours)									
Maximum Ponding Depth (ft)									
Area at Maximum Ponding Depth (acres)									
Maximum Volume Stored (acre-ft)									

Unresolved: provide all preliminary design data

DETENTION BASIN OUTLET STRUCTURE DESIGN

MHFD-Detention, Version 4.04 (February 2021)

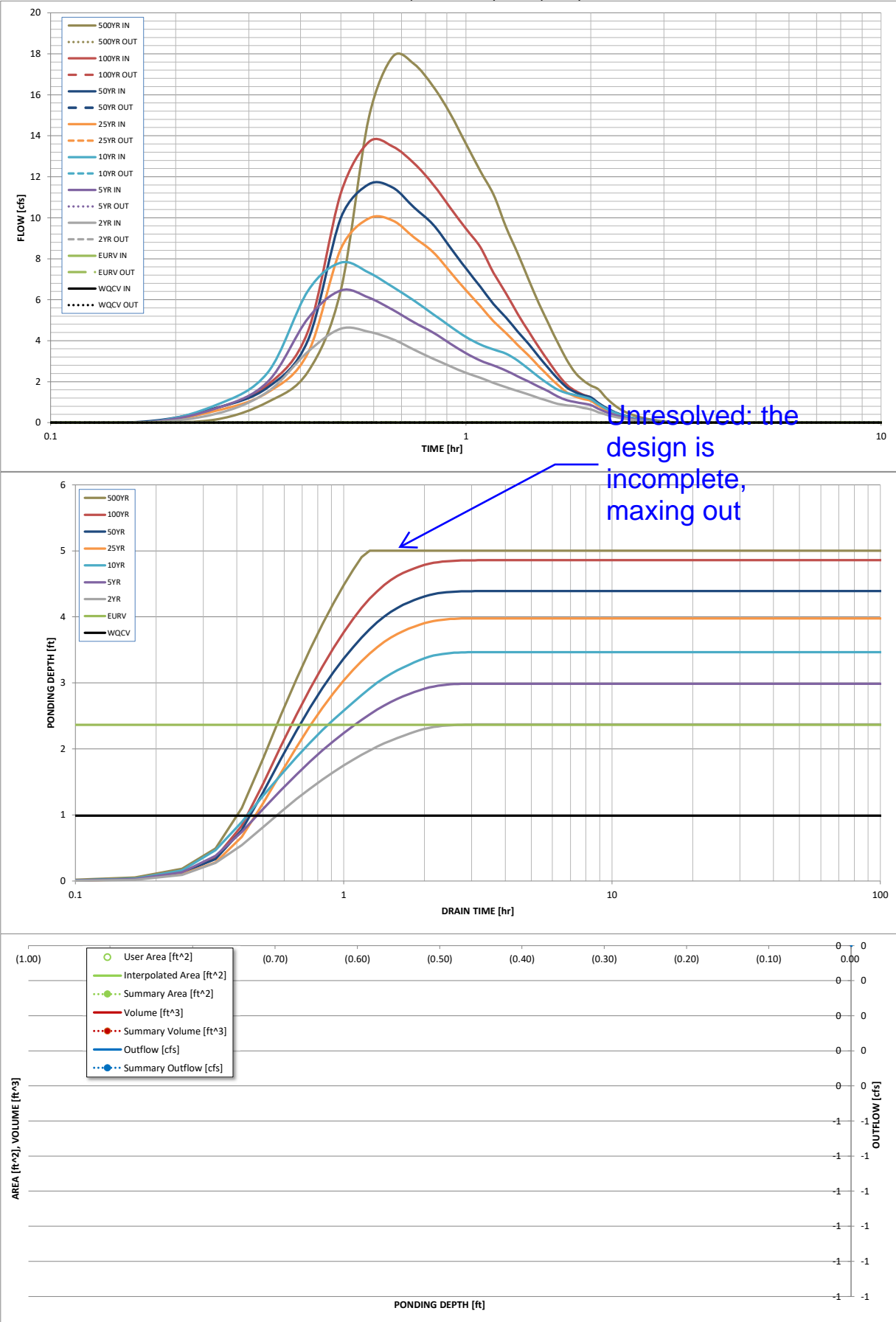

S-A-V-D Chart Axis Override	X-axis	Left Y-Axis	Right Y-Axis
minimum bound			
maximum bound			

DETENTION BASIN OUTLET STRUCTURE DESIGN

MHFD-Detention, Version 4.04 (February 2021)

Project: Monument Ridge East

Basin ID: Pond 4 Qmax out = 90% PreDev Q, Q10=16.1cfs, Q100=39.4cfs

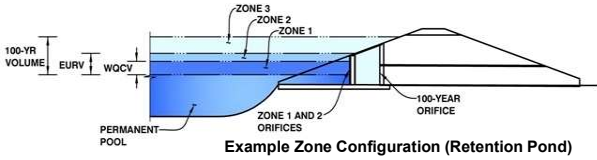

	Estimated Stage (ft)	Estimated Volume (ac-ft)	Outlet Type
Zone 1	#N/A		
Zone 2			
Zone 3			
Total (all zones)			

User Input: Orifice at Underdrain Outlet (typically used to drain WQCV in a Filtration BMP)

Underdrain Orifice Invert Depth = ft (distance below the filtration media surface)
 Underdrain Orifice Diameter = inches

Underdrain Orifice Area = ft²
 Underdrain Orifice Centroid = feet

User Input: Orifice Plate with one or more orifices or Elliptical Slot Weir (typically used to drain WQCV and/or EURV in a sedimentation BMP)

Invert of Lowest Orifice = ft (relative to basin bottom at Stage = 0 ft)
 Depth at top of Zone using Orifice Plate = ft (relative to basin bottom at Stage = 0 ft)
 Orifice Plate: Orifice Vertical Spacing = inches
 Orifice Plate: Orifice Area per Row = inches

Calculated Parameters for Plate
 WQ Orifice Area per Row = ft²
 Elliptical Half-Width = feet
 Elliptical Slot Centroid = feet
 Elliptical Slot Area = ft²

User Input: Stage and Total Area of Each Orifice Row (numbered from lowest to highest)

	Row 1 (optional)	Row 2 (optional)	Row 3 (optional)	Row 4 (optional)	Row 5 (optional)	Row 6 (optional)	Row 7 (optional)	Row 8 (optional)
Stage of Orifice Centroid (ft)	<input type="text"/>	<input type="text"/>	<input type="text"/>	<input type="text"/>	<input type="text"/>	<input type="text"/>	<input type="text"/>	<input type="text"/>
Orifice Area (sq. inches)	<input type="text"/>	<input type="text"/>	<input type="text"/>	<input type="text"/>	<input type="text"/>	<input type="text"/>	<input type="text"/>	<input type="text"/>
	Row 9 (optional)	Row 10 (optional)	Row 11 (optional)	Row 12 (optional)	Row 13 (optional)	Row 14 (optional)	Row 15 (optional)	Row 16 (optional)
Stage of Orifice Centroid (ft)	<input type="text"/>	<input type="text"/>	<input type="text"/>	<input type="text"/>	<input type="text"/>	<input type="text"/>	<input type="text"/>	<input type="text"/>
Orifice Area (sq. inches)	<input type="text"/>	<input type="text"/>	<input type="text"/>	<input type="text"/>	<input type="text"/>	<input type="text"/>	<input type="text"/>	<input type="text"/>

User Input: Vertical Orifice (Circular or Rectangular)

Invert of Vertical Orifice = Not Selected Not Selected ft (relative to basin bottom at Stage = 0 ft)
 Depth at top of Zone using Vertical Orifice = ft (relative to basin bottom at Stage = 0 ft)
 Vertical Orifice Diameter = inches

Calculated Parameters for Vertical Orifice
 Vertical Orifice Area = Not Selected Not Selected ft²
 Vertical Orifice Centroid = feet

User Input: Overflow Weir (Dropbox with Flat or Sloped Gate and Outlet Pipe OR Rectangular/Trapezoidal Weir (and No Outlet Pipe))

Overflow Weir Front Edge Height, Ho = Not Selected Not Selected ft (relative to basin bottom at Stage = 0 ft)
 Overflow Weir Front Edge Length = feet
 Overflow Weir Gate Slope = H:V
 Horiz. Length of Weir Sides = feet
 Overflow Gate Type =
 Debris Clogging % = %

Calculated Parameters for Overflow Weir
 Height of Gate Upper Edge, H_g = feet
 Overflow Weir Slope Length = feet
 Gate Open Area / 100-yr Orifice Area =
 Overflow Gate Open Area w/o Debris = ft²
 Overflow Gate Open Area w/ Debris = ft²

User Input: Outlet Pipe w/ Flow Restriction Plate (Circular Orifice, Restrictor Plate, or Rectangular Orifice)

Depth to Invert of Outlet Pipe = Not Selected Not Selected ft (distance below basin bottom at Stage = 0 ft)
 Circular Orifice Diameter = inches

Calculated Parameters for Outlet Pipe w/ Flow Restriction Plate
 Outlet Orifice Area = ft²
 Outlet Orifice Centroid = feet
 Half-Central Angle of Restrictor Plate on Pipe = N/A N/A radians

User Input: Emergency Spillway (Rectangular or Trapezoidal)

Spillway Invert Stage = ft (relative to basin bottom at Stage = 0 ft)
 Spillway Crest Length = feet
 Spillway End Slopes = H:V
 Freeboard above Max Water Surface = feet

Calculated Parameters for Spillway
 Spillway Design Flow Depth = feet
 Stage at Top of Freeboard = feet
 Basin Area at Top of Freeboard = acres
 Basin Volume at Top of Freeboard = acre-ft

Routed Hydrograph Results

The user can override the default CUHP hydrographs and runoff volumes by entering new values in the Inflow Hydrographs table (Columns W through AF).

	WQCV	EURV	2 Year	5 Year	10 Year	25 Year	50 Year	100 Year	500 Year
Design Storm Return Period	N/A	N/A	1.19	1.50	1.75	2.00	2.25	2.52	3.14
One-Hour Rainfall Depth (in)	0.345	0.929	0.965	1.433	1.860	2.410	2.867	3.450	4.627
CUHP Runoff Volume (acre-ft)	N/A	N/A	0.965	1.433	1.860	2.410	2.867	3.450	4.627
Inflow Hydrograph Volume (acre-ft)	N/A	N/A	5.4	12.1	17.9	28.6	35.3	43.8	60.7
CUHP Predevelopment Peak Q (cfs)	N/A	N/A	5.4	12.1	17.9	28.6	35.3	43.8	60.7
OPTIONAL Override Predevelopment Peak Q (cfs)	N/A	N/A							
Predevelopment Unit Peak Flow, q (cfs/acre)	N/A	N/A	0.24	0.53	0.79	1.26	1.55	1.92	2.67
Peak Inflow Q (cfs)	N/A	N/A	20.6	31.0	38.4	50.2	59.4	71.8	94.5
Peak Outflow Q (cfs)									
Ratio Peak Outflow to Predevelopment Q									
Structure Controlling Flow									
Max Velocity through Gate 1 (fps)									
Max Velocity through Gate 2 (fps)									
Time to Drain 97% of Inflow Volume (hours)									
Time to Drain 99% of Inflow Volume (hours)									
Maximum Ponding Depth (ft)									
Area at Maximum Ponding Depth (acres)									
Maximum Volume Stored (acre-ft)									

Unresolved: provide all preliminary design data

DETENTION BASIN OUTLET STRUCTURE DESIGN

MHFD-Detention, Version 4.04 (February 2021)

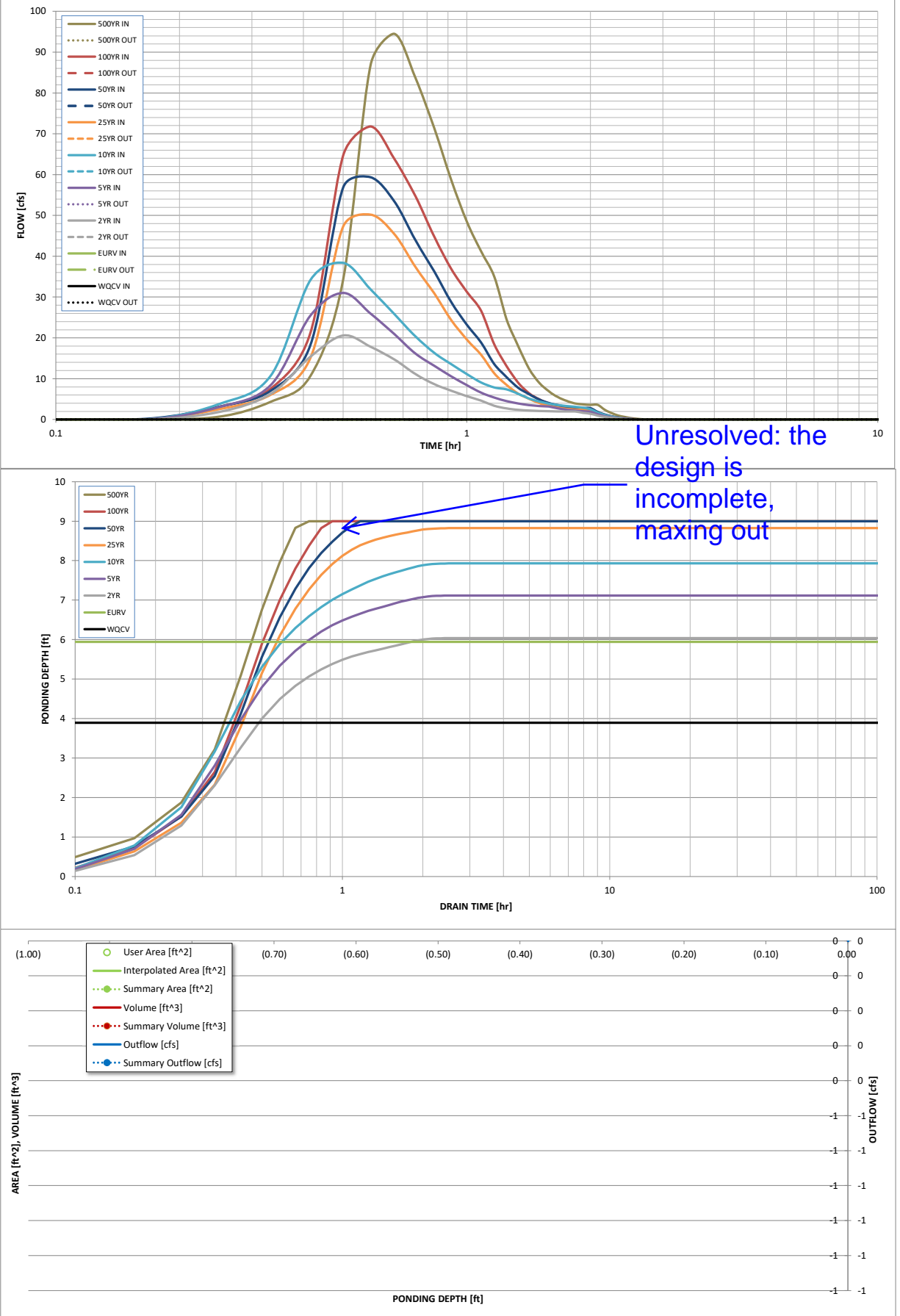

Unresolved: the design is incomplete, maxing out

S-A-V-D Chart Axis Override	X-axis	Left Y-Axis	Right Y-Axis
minimum bound			
maximum bound			

DETENTION BASIN STAGE-STORAGE TABLE BUILDER

MHFD-Detention, Version 4.04 (February 2021)

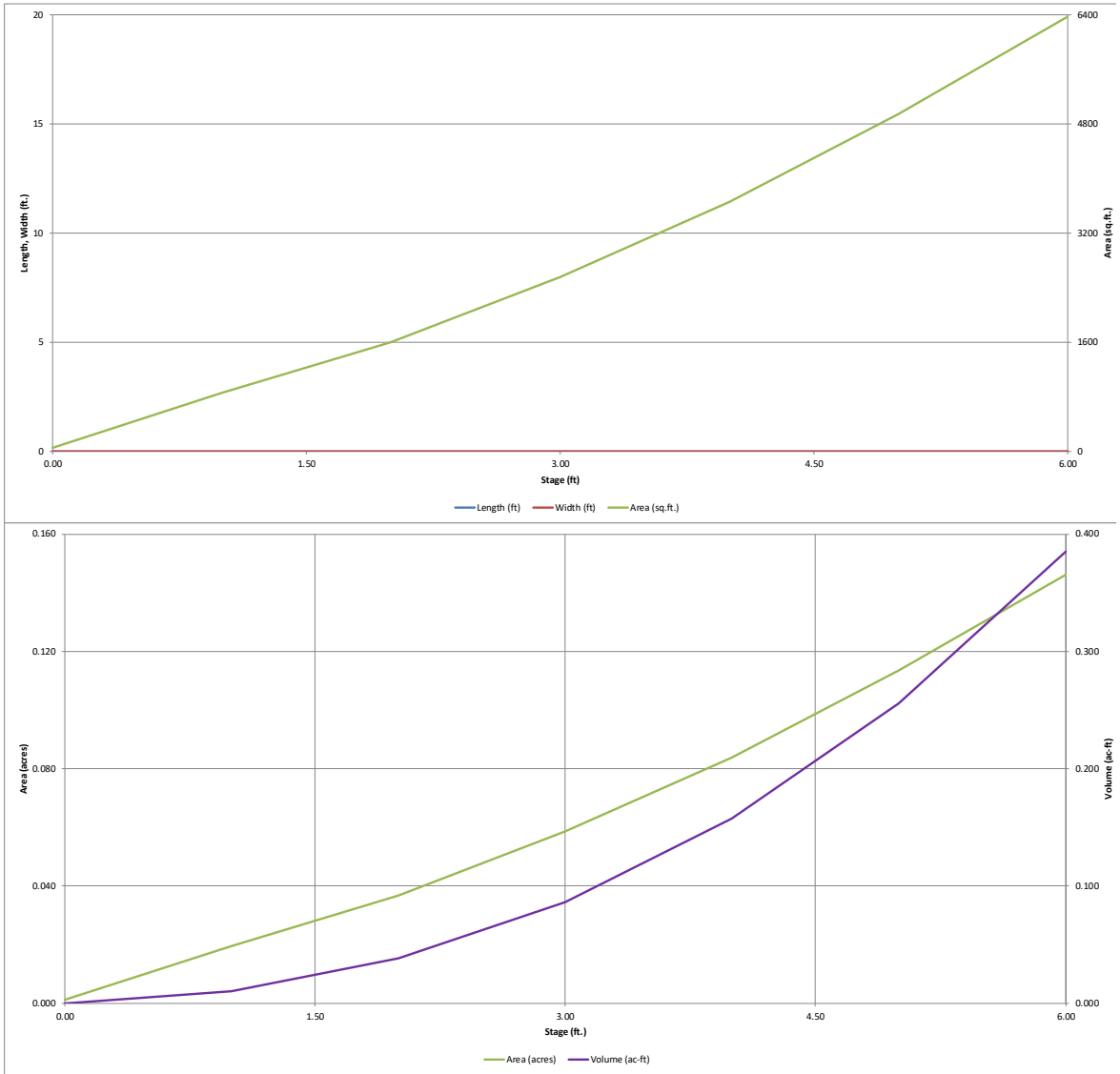

DETENTION BASIN OUTLET STRUCTURE DESIGN

MHFD-Detention, Version 4.04 (February 2021)

Project: Monument Ridge East
Basin ID: Pond 5 Qmax out = 90% PreDev Q. Q10=2.1cfs, Q100=5.5cfs

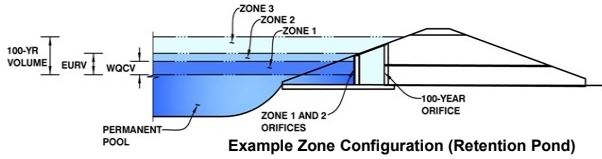

Example Zone Configuration (Retention Pond)

	Estimated Stage (ft)	Estimated Volume (ac-ft)	Outlet Type
Zone 1	#N/A		
Zone 2			
Zone 3			
Total (all zones)			

User Input: Orifice at Underdrain Outlet (typically used to drain WQCV in a Filtration BMP)

Underdrain Orifice Invert Depth = ft (distance below the filtration media surface)

Underdrain Orifice Diameter = inches

Calculated Parameters for Underdrain

Underdrain Orifice Area = ft²

Underdrain Orifice Centroid = feet

User Input: Orifice Plate with one or more orifices or Elliptical Slot Weir (typically used to drain WQCV and/or EURV in a sedimentation BMP)

Invert of Lowest Orifice = ft (relative to basin bottom at Stage = 0 ft)

Depth at top of Zone using Orifice Plate = ft (relative to basin bottom at Stage = 0 ft)

Orifice Plate: Orifice Vertical Spacing = inches

Orifice Plate: Orifice Area per Row = inches

Calculated Parameters for Plate

WQ Orifice Area per Row = N/A ft²

Elliptical Half-Width = N/A feet

Elliptical Slot Centroid = N/A feet

Elliptical Slot Area = N/A ft²

User Input: Stage and Total Area of Each Orifice Row (numbered from lowest to highest)

	Row 1 (optional)	Row 2 (optional)	Row 3 (optional)	Row 4 (optional)	Row 5 (optional)	Row 6 (optional)	Row 7 (optional)	Row 8 (optional)
Stage of Orifice Centroid (ft)	<input type="text"/>	<input type="text"/>	<input type="text"/>	<input type="text"/>	<input type="text"/>	<input type="text"/>	<input type="text"/>	<input type="text"/>
Orifice Area (sq. inches)	<input type="text"/>	<input type="text"/>	<input type="text"/>	<input type="text"/>	<input type="text"/>	<input type="text"/>	<input type="text"/>	<input type="text"/>

	Row 9 (optional)	Row 10 (optional)	Row 11 (optional)	Row 12 (optional)	Row 13 (optional)	Row 14 (optional)	Row 15 (optional)	Row 16 (optional)
Stage of Orifice Centroid (ft)	<input type="text"/>	<input type="text"/>	<input type="text"/>	<input type="text"/>	<input type="text"/>	<input type="text"/>	<input type="text"/>	<input type="text"/>
Orifice Area (sq. inches)	<input type="text"/>	<input type="text"/>	<input type="text"/>	<input type="text"/>	<input type="text"/>	<input type="text"/>	<input type="text"/>	<input type="text"/>

User Input: Vertical Orifice (Circular or Rectangular)

	Not Selected	Not Selected		Not Selected	Not Selected
Invert of Vertical Orifice =	<input type="text"/>	<input type="text"/>	ft (relative to basin bottom at Stage = 0 ft)	Vertical Orifice Area =	<input type="text"/>
Depth at top of Zone using Vertical Orifice =	<input type="text"/>	<input type="text"/>	ft (relative to basin bottom at Stage = 0 ft)	Vertical Orifice Centroid =	<input type="text"/>
Vertical Orifice Diameter =	<input type="text"/>	<input type="text"/>	inches		

User Input: Overflow Weir (Dropbox with Flat or Sloped Gate and Outlet Pipe OR Rectangular/Trapezoidal Weir (and No Outlet Pipe))

	Not Selected	Not Selected		Not Selected	Not Selected
Overflow Weir Front Edge Height, Ho =	<input type="text"/>	<input type="text"/>	ft (relative to basin bottom at Stage = 0 ft)	Height of Gate Upper Edge, H ₁ =	<input type="text"/>
Overflow Weir Front Edge Length =	<input type="text"/>	<input type="text"/>	feet	Overflow Weir Slope Length =	<input type="text"/>
Overflow Weir Gate Slope =	<input type="text"/>	<input type="text"/>	H:V	Gate Open Area / 100-yr Orifice Area =	<input type="text"/>
Horiz. Length of Weir Sides =	<input type="text"/>	<input type="text"/>	feet	Overflow Gate Open Area w/o Debris =	<input type="text"/>
Overflow Gate Type =	<input type="text"/>	<input type="text"/>		Overflow Gate Open Area w/ Debris =	<input type="text"/>
Debris Clogging % =	<input type="text"/>	<input type="text"/>	%		

User Input: Outlet Pipe w/ Flow Restriction Plate (Circular Orifice, Restrictor Plate, or Rectangular Orifice)

	Not Selected	Not Selected		Not Selected	Not Selected
Depth to Invert of Outlet Pipe =	<input type="text"/>	<input type="text"/>	ft (distance below basin bottom at Stage = 0 ft)	Outlet Orifice Area =	<input type="text"/>
Circular Orifice Diameter =	<input type="text"/>	<input type="text"/>	inches	Outlet Orifice Centroid =	<input type="text"/>
				Half-Central Angle of Restrictor Plate on Pipe =	<input type="text"/> N/A

User Input: Emergency Spillway (Rectangular or Trapezoidal)

Spillway Invert Stage =	<input type="text"/>	ft (relative to basin bottom at Stage = 0 ft)	Spillway Design Flow Depth =	<input type="text"/>	feet
Spillway Crest Length =	<input type="text"/>	feet	Stage at Top of Freeboard =	<input type="text"/>	feet
Spillway End Slopes =	<input type="text"/>	H:V	Basin Area at Top of Freeboard =	<input type="text"/>	acres
Freeboard above Max Water Surface =	<input type="text"/>	feet	Basin Volume at Top of Freeboard =	<input type="text"/>	acre-ft

Routed Hydrograph Results The user can override the default CUHP hydrographs and runoff volumes by entering new values in the Inflow Hydrographs table (Columns W through AF)

	WQCV	EURV	2 Year	5 Year	10 Year	25 Year	50 Year	100 Year
Design Storm Return Period	N/A	N/A						
One-Hour Rainfall Depth (in)	N/A	N/A	1.19	1.50	1.75	2.00	2.25	2.52
CUHP Runoff Volume (acre-ft)	0.054	0.166	0.146	0.210	0.266	0.343	0.404	0.483
Inflow Hydrograph Volume (acre-ft)	N/A	N/A	0.146	0.210	0.266	0.343	0.404	0.483
CUHP Predevelopment Peak Q (cfs)	N/A	N/A	0.6	1.5	2.3	3.9	4.8	6.1
OPTIONAL Override Predevelopment Peak Q (cfs)	N/A	N/A						
Predevelopment Unit Peak Flow, q (cfs/acre)	N/A	N/A	0.17	0.47	0.72	1.21	1.50	1.89
Peak Inflow Q (cfs)	N/A	N/A	3.3	4.8	5.9	7.6	9.1	10.8
Peak Outflow Q (cfs)								
Ratio Peak Outflow to Predevelopment Q								
Structure Controlling Flow								
Max Velocity through Gate 1 (fps)								
Max Velocity through Gate 2 (fps)								
Time to Drain 97% of Inflow Volume (hours)								
Time to Drain 99% of Inflow Volume (hours)								
Maximum Ponding Depth (ft)								
Area at Maximum Ponding Depth (acres)								
Maximum Volume Stored (acre-ft)								

Unresolved: provide all preliminary design data

DETENTION BASIN OUTLET STRUCTURE DESIGN

MHFD-Detention, Version 4.04 (February 2021)

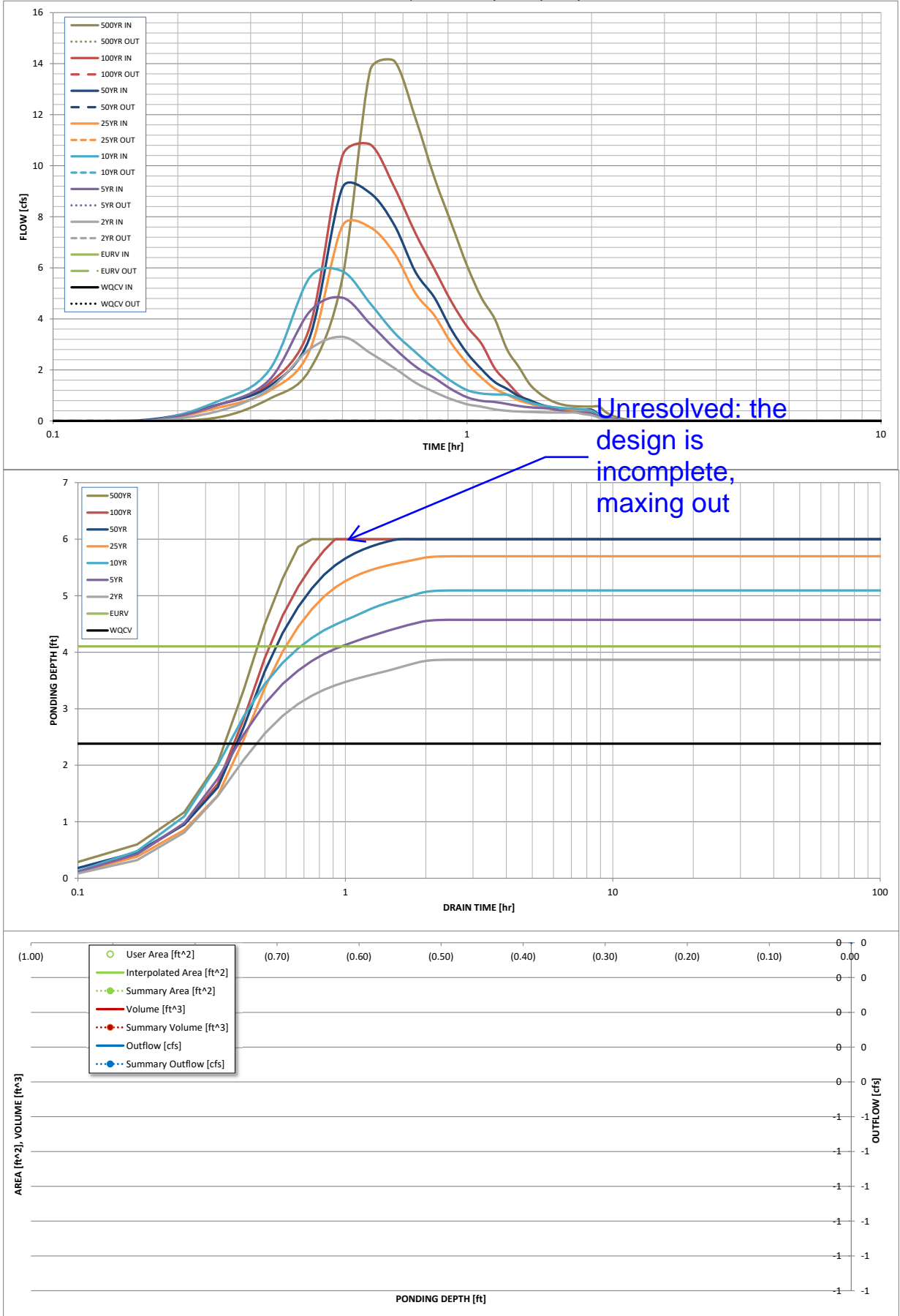

S-A-V-D Chart Axis Override	X-axis	Left Y-Axis	Right Y-Axis
minimum bound			
maximum bound			



Surface Routing Summary				
Design Point	Design Point/ Contributing Basins	Flow		Comments
		Q ₁₀	Q ₁₀₀	
1	E2	3.3	5.7	existing 36" RCP culvert
2	DP1,E1	21.8	62.2	existing dual 48" RCP culverts
3	DP2,E3	107.2	225.6	Misty Ac 1 Pond Attenuation of Q10=55cfs, Q100=130cfs (per MDDP), yields Q10out=49.2cfs and Q100=95.6cfs
4	E4	92.1	191.4	unk pipe sizes, assume no peak flow attenuation
5	DP4,E5	109.4	225.2	low point collection structure, size TBD in FDR
6	DP3 (attenuated),DP5,E6,E7	214.3	488.0	existing 48" CMP culvert, overtops road
7	E8	40.8	113.3	existing 48" CMP culvert
8	DP7,E9,E10	52.9	137.4	existing 48" RCP culvert, overtop elev unk
9	DP8,E11	60.1	151.4	existing 48" RCP culvert, overtop elev unk
10	E6	4.7	8.0	existing 24" culvert

LEGEND

- BASIN ID
- % IMPERVIOUS
- BASIN AREA (ACRES)
- DESIGN POINT
- DRAINAGE BASIN BOUNDARY
- EXISTING CONTOUR
- PROPOSED CONTOUR
- SURFACE FLOW DIRECTION

GENERAL NOTES

- EXISTING TOPOGRAPHY PROVIDED BY THE COLORADO WATER CONSERVATION BOARD (CWCB).
- ALL CONTOURS REFLECT EXISTING CONDITIONS.
- CONTOURS SHOWN ON THIS MAP REFLECT A 5' CONTOUR INTERVAL.
- AERIAL IMAGERY FROM GOOGLE EARTH DATED 2019

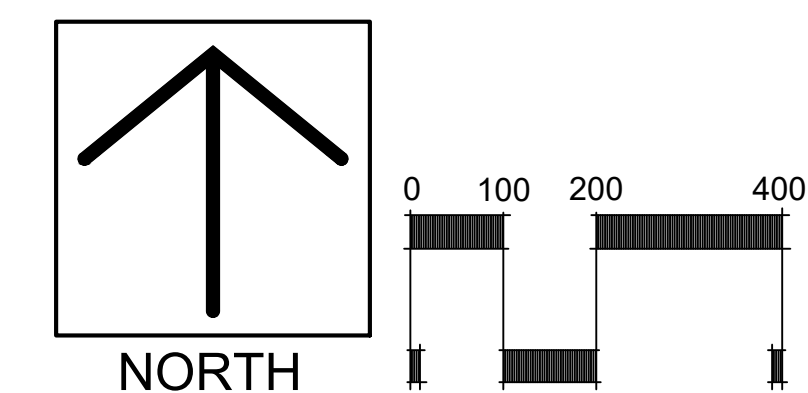



Pipe Summary

Flow (cfs)	Q ₁₀	Q ₁₀₀	Pipe Diam (in)
1A	5.8	17.2	30" RCP
1B	5.8	17.2	30" RCP
1C	5.8	17.2	30" RCP
1D	5.8	17.2	30" RCP
1E	6.0	9.6	18" RCP
2	22.0	38.4	30" RCP
3	9.0	15.0	24" RCP
4	31.0	50.4	36" RCP
5	5.7	9.7	18" RCP
6	5.7	9.7	18" RCP
7	36.7	60.0	36" RCP
8	7.1	20.7	18" RCP
9	NOT USED	NOT USED	
10	NOT USED	NOT USED	
11	9.4	15.3	24" RCP
12	19.7	30.6	24" RCP
13A	7.3	12.3	24" RCP
13B	14.6	24.7	30" RCP
14	7.3	12.3	24" RCP
15	11.8	19.6	24" RCP
16	7.5	12.2	24" RCP
17	19.3	31.8	30" RCP
18	26.6	44.1	36" RCP
19	5.4	9.5	24" RCP
20	19.9	18.9	24" RCP
21	42.6	71.4	42" RCP
22	69.2	115.5	42" RCP
23	1.0	1.8	18" RCP
24	1.9	3.5	18" RCP
25	2.9	5.3	18" RCP
26	7.5	12.8	24" RCP
27	10.3	18.1	24" RCP
28	15.4	27.9	24" RCP
29	10.6	28.3	24" RCP
30	12.2	21.9	30" RCP
31	22.1	38.3	36" RCP
32	21.1	36.8	18" RCP
33	12.7	33.9	36" RCP
34	12.7	33.9	36" RCP
35	9.2	17.5	24" RCP
36	18.5	34.9	30" RCP
37A	7.9	15.1	24" RCP
37B	15.9	30.2	30" RCP
37C	4.2	11.7	18" RCP
37D	22.0	42.0	30" RCP
38	28.2	53.7	36" RCP
39	2.6	5.4	18" RCP
40	3.8	7.5	24" RCP
41	16.1	39.4	36" RCP
42	28.8	73.3	42" RCP
43	9.3	17.4	24" RCP
44	2.1	4.5	18" RCP
45	60.9	108.3	54" RCP
46	61.9	111.0	54" RCP
47	61.9	111.0	54" RCP
48	164.5	322.3	78" RCP
49	164.5	322.3	78" RCP

Surface Routing Summary

Design Point	Design Point/Contributing Basins	Q ₁₀	Q ₁₀₀	Comments
1	E2	3.3	5.7	existing 36" RCP culvert
2	DP1.E1	21.8	62.2	existing dual 48" RCP culverts
3	DP2.E3	107.2	225.6	Misty Ac 1 Pond Attenuation of Q10=58cfs, Q100=100cfs (per MDDP), plus Q10=49.2cfs and Q100=95.6cfs
4	E4	92.1	191.4	unk pipe sizes, assume no peak flow attenuation
5	DP4.E5	109.4	225.2	low point collection structure, size TBD in FDR
6	DP3 (attenuated), DP5, E6, E7	214.3	488.0	existing 48" CMP culvert, overlaps road
7	E8	40.8	113.3	existing 48" CMP culvert
8	DP7, E9, E10	82.9	137.4	existing 48" RCP culvert, overlap elev unk
9	DP8, E11	60.1	151.4	existing 48" RCP culvert, overlap elev unk
10	E6	4.7	8.0	existing 24" culvert
11	O1	5.8	17.2	proposed 18" RCP
12	O2	2.1	3.5	existing type C inlet
13A	A1(30%)	6.0	9.6	proposed 2-4" D-10-R inlets
13B	DP12, A1(70%)	16.0	25.8	proposed 2-16" D-10-R inlets
14	A2	9.0	15.0	split w/DP13 flows, proposed 4" and 16" D-10-R inlets
15	O3	3.3	5.7	existing 36" RCP culvert
16	O4	3.0	4.9	existing type C inlet
17	DP15, DP16	5.7	9.7	existing 18" RCP culvert
18	DP13A, DP13B, DP14, DP17	36.7	60.0	proposed manhole
19	DP11, A3	7.1	20.7	proposed 18" RCP culvert
20	A4	18.7	30.6	proposed 2-12" D-10-R inlets
21	DP18, DP19	43.8	80.7	flow to pond 1, not routed
22	DP20, DP21, A5	118.4	118.4	total flow to pond 1, not routed
23	B1	14.6	24.7	proposed 2-4" D-10-R inlets
24	B2	11.8	19.6	split w/DP25 flows, proposed triple type R inlets
25	B3	7.5	12.2	split w/DP24 flows, proposed triple type R inlets
26	DP23, DP24, DP25	53.9	56.5	proposed manhole
27	BB	10.9	18.9	proposed 2-8" D-10-R inlets
28	B4(80%)	3.1	5.0	proposed double type 16 inlet
28A	B4(40%)	2.1	3.3	proposed double type 16 inlet
28B	DP26, DP27, DP28, DP29A	49.9	83.7	proposed manhole
29	B5(33%)	1.0	1.8	proposed single type R inlet
30	B5(66%)	1.9	3.5	proposed single type R inlet
31	B6	7.5	12.8	proposed double type R inlet
32	B7	5.1	9.7	proposed double type R inlet

Surface Routing Summary

Design Point	Design Point/Contributing Basins	Q ₁₀	Q ₁₀₀	Comments
34	DP23, DP24, DP25, DP27, DP28, DP 29, DP30, DP31, DP32, DP33, B9	69.8	119.2	total flow to pond 2, not routed
35	C1	12.2	21.9	split w/DP36 flows, proposed triple type R inlets
36	C2	9.8	16.4	split w/DP35 flows, proposed triple type R inlets
37	DP35, DP36, C3	23.3	40.6	total flow to pond 3, not routed
38	Pond 2 out, Pond 3 out	12.7	37.9	proposed manhole
39	D1	18.5	34.9	proposed 2-16" D-10-R inlets
40a	D2(25%)	7.9	15.1	split w/DP40b flows, proposed 12" D-10-R inlet
40b	D2(25%)	7.9	15.1	split w/DP40a flows, proposed 12" D-10-R inlet
40c	D2(50%)	12.3	23.4	proposed 2-12" D-10-R inlets
41	DP38, DP40a, DP40b, DP40c, D5(50%)	48.0	92.0	total flow to pond 4 (south side)
42	D3	2.6	5.4	split with DP43 flows, proposed 4" D-10-R inlet
43	D4	1.3	2.1	split with DP42 flows, proposed 4" D-10-R inlet
44	DP42, DP43, D5(50%)	5.2	10.9	total flow to pond 4 (south side)
45	DP38, Pond 4 out	28.8	77.3	proposed manhole
46	E	9.3	17.4	proposed 16" D-10-R inlet
47	Pond 5 outfall	2.1	5.5	total flow release
48	Pond 1 out, O5	118.9	238.3	Misty Ac 1 Pond Attenuation of Q10=58cfs, Q100=100cfs (per MDDP), plus Q10=49.2cfs and Q100=95.6cfs

Surface Routing Summary

Design Point	Design Point/Contributing Basins	Q ₁₀	Q ₁₀₀	Comments
49	O6	1.0	2.7	proposed type C inlet
50	O7A	92.1	191.4	total flow to existing pond, no peak flow attenuation
51	DP50, O7B	110.5	227.8	existing dual 48" CMP culverts
52	DP51	102.6	211.3	low point collection structure, size TBD in FDR
53	O8	4.7	8.0	as culvert, size unk
54	DP45, DP47, DP48, OUT, DP49, DP52, DP53, O9	212.2	436.4	total inflow
55	DP54 Pipe Out	212.2	436.4	existing 48" culvert outfall, add 2-48" RCP's
56	O10	40.8	113.3	existing 48" CMP culvert
57	DP56, O11	47.7	124.4	existing type C inlet
58	DP57, O12	61.7	133.3	existing 48" RCP culvert
59	DP58, O13	69.3	147.5	existing 48" RCP culvert

LEGEND

- BASIN ID
- % IMPERVIOUS
- BASIN AREA (ACRES)
- DESIGN POINT
- DRAINAGE BASIN BOUNDARY
- EXISTING CONTOUR
- PROPOSED CONTOUR
- SURFACE FLOW DIRECTION

- GENERAL NOTES**
- EXISTING TOPOGRAPHY PROVIDED BY THE COLORADO WATER CONSERVATION BOARD (CWCB)
 - ALL CONTOURS REFLECT EXISTING CONDITIONS.
 - CONTOURS SHOWN ON THIS MAP REFLECT A 5' CONTOUR INTERVAL.
 - AERIAL IMAGERY NOT SHOWN FOR CLARIFICATION.
 - ALL BASINS FOR THE SITE HAVE BEEN SHOWN HEREIN, HOWEVER THE SUB-BASINS HAVE BEEN GENERALLY LABELED TO CORRESPOND WITH THE MAJOR BASIN (E.G. - BASINS A1 THRU A7 ARE LABELED AS 'A' ON THE MAP).

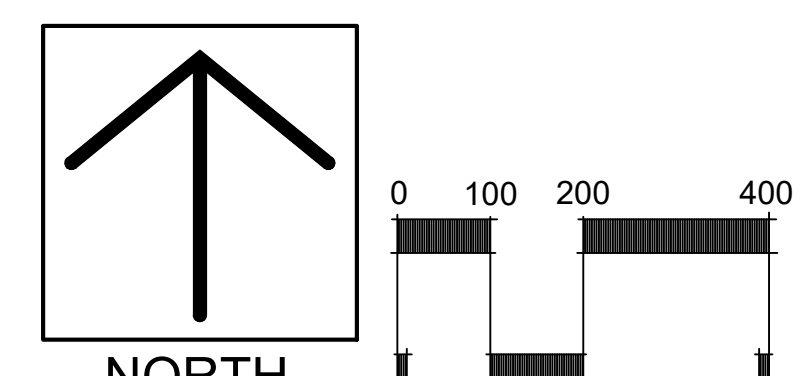

MONUMENT RIDGE EAST
TOWN OF MONUMENT
EL PASO COUNTY, COLORADO

◆ DRAINAGE PLAN
DEVELOPED CONDITIONS - OVERALL

Issued: 8/4/24

D2
sheet number

PRC ENGINEERS
4405 S. MONUMENT DRIVE, SUITE 400A
COLORADO SPRINGS, CO 80907

PRC
ENGINEERING

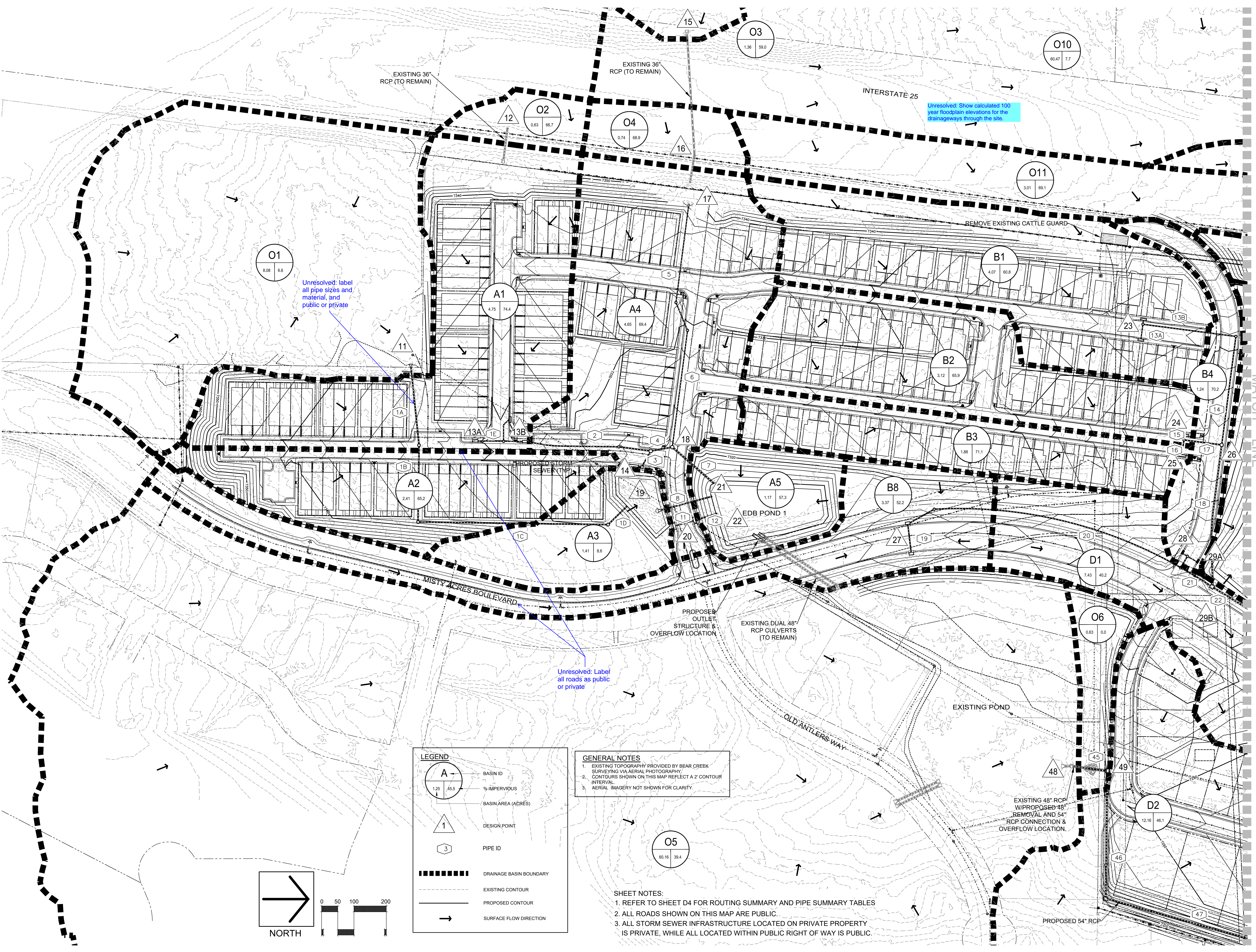

Unresolved: label all pipe sizes and material, and public or private

Unresolved: Show calculated 100 year floodplain elevations for the drainageways through the site.

Unresolved: Label all roads as public or private

LEGEND	
	BASIN ID
	% IMPERVIOUS
	BASIN AREA (ACRES)
	DESIGN POINT
	PIPE ID
	DRAINAGE BASIN BOUNDARY
	EXISTING CONTOUR
	PROPOSED CONTOUR
	SURFACE FLOW DIRECTION

GENERAL NOTES
 1. EXISTING TOPOGRAPHY PROVIDED BY BEAR CREEK SURVEYING VIA AERIAL PHOTOGRAPHY.
 2. CONTOURS SHOWN ON THIS MAP REFLECT A 2' CONTOUR INTERVAL.
 3. AERIAL IMAGERY NOT SHOWN FOR CLARITY.

SHEET NOTES:
 1. REFER TO SHEET D4 FOR ROUTING SUMMARY AND PIPE SUMMARY TABLES
 2. ALL ROADS SHOWN ON THIS MAP ARE PUBLIC.
 3. ALL STORM SEWER INFRASTRUCTURE LOCATED ON PRIVATE PROPERTY IS PRIVATE, WHILE ALL LOCATED WITHIN PUBLIC RIGHT OF WAY IS PUBLIC.

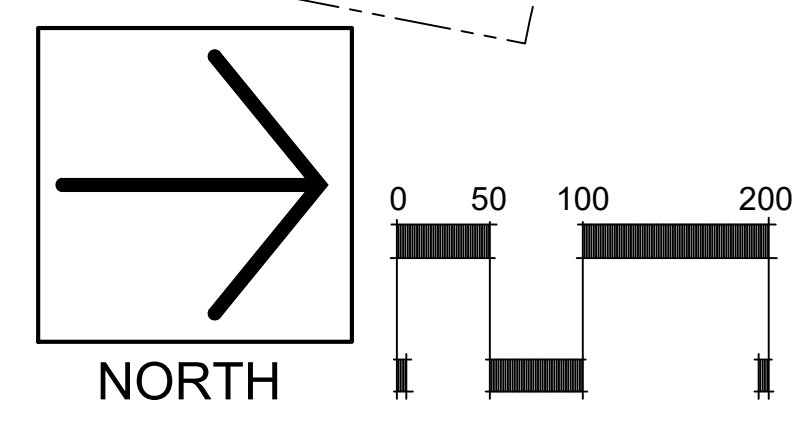

Issued	8/4/24

Unresolved: add a column for public/private

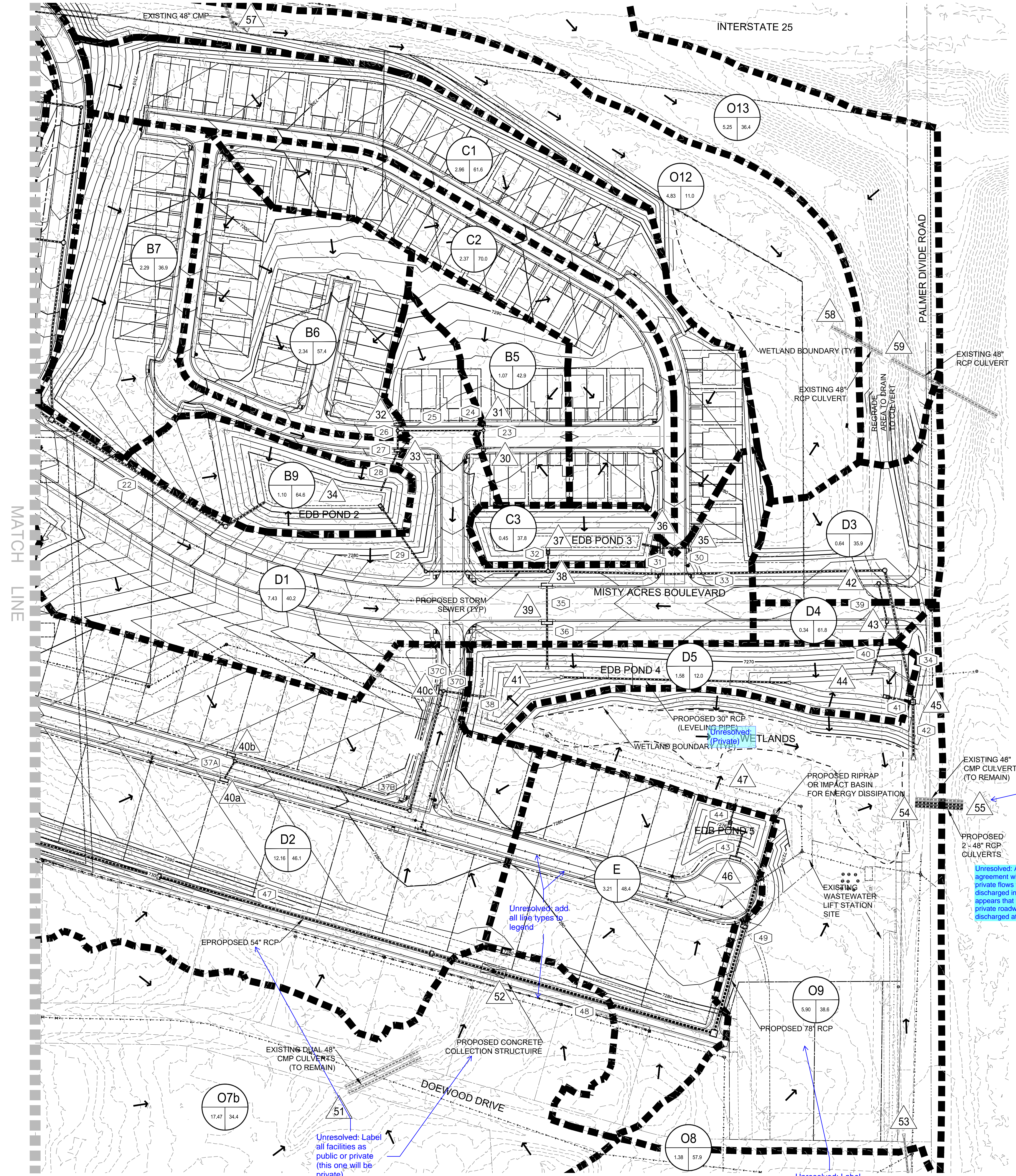

Surface Routing Summary				
Design Point	Design Point/Contributing Basins	Flow		Comments
		Q ₁₀	Q ₁₀₀	
1	E2	3.3	5.7	existing 36" RCP culvert
2	DP1,E1	21.8	62.2	existing dual 48" RCP culverts
3	DP2,E3	107.2	228.6	Misty Ac 1 Pond Attenuation of Q10-58cfs, Q100=130cfs (per MDDP), yields Q10out=49.2cfs and Q100=108.3cfs
4	E4	92.1	191.4	unl pipe sizes, assume no peak flow attenuation
5	DP4,E5	109.4	226.2	low point collection structure, size TBD in FDR
6	DP3 (unlabeled),DP5,E6,E7	214.3	488.0	existing 48" CMP culvert, overlap road
7	E8	40.8	113.3	existing 48" CMP culvert
8	DP7,E9,E10	52.9	137.4	existing 48" RCP culvert, overlap elev unlk
9	DP8,E11	60.1	151.4	existing 48" RCP culvert, overlap elev unlk
10	E6	4.7	8.0	existing 24" culvert
11	O1	5.8	17.2	proposed 18" RCP
12	O2	2.1	3.5	existing type C inlet
13A	A1(30%)	6.0	9.6	proposed 2-4" D-10-R inlets
13B	DP12,A1(70%)	16.0	25.8	proposed 2-16" D-10-R inlets
14	A2	9.0	15.0	split w/DP13 flows, proposed 4" and 16" D-10-R inlets
15	O3	3.3	5.7	existing 36" RCP culvert
16	O4	3.0	4.9	existing type C inlet
17	DP15,DP16	5.7	9.7	proposed 18" RCP culvert
18	DP13A, DP13B, DP14, DP17	36.7	60.0	proposed manhole
19	DP11,A3	7.1	20.7	proposed 18" RCP culvert
20	A4	18.7	30.6	proposed 2-12" D-10-R inlets
21	DP18,DP19	43.8	80.7	flow to pond 1, unrouled
22	DP20,DP21,A5	66.7	118.4	total flow to pond 1, not rouled
23	B1	14.6	24.7	proposed 2-8" D-10-R inlets
24	B2	11.8	19.6	split w/DP25 flows, proposed triple type R inlets
25	B3	7.5	12.2	split w/DP24 flows, proposed triple type R inlets
26	DP23,DP24,DP25	33.9	66.6	proposed manhole
27	B8	10.9	18.9	proposed 2-8" D-10-R inlets
28	B4(60%)	3.1	5.0	proposed double type 16 inlet
28A	B4(40%)	2.1	3.3	proposed double type 16 inlet
29B	DP26,DP27,DP28,DP29A	49.9	83.7	proposed manhole
30	B5(33%)	1.0	1.8	proposed single type R inlet
31	B5(66%)	1.9	3.5	proposed single type R inlet
32	B6	7.5	12.8	proposed double type R inlet
33	B7	5.1	9.7	proposed double type R inlet
34	DP23,DP24,DP25,DP27,DP28,DP29,DP30,DP31,DP32,DP33,B9	69.8	119.2	total flow to pond 2, not rouled
35	C1	12.2	21.9	split w/DP36 flows, proposed triple type R inlets
36	C2	9.9	16.4	split w/DP35 flows, proposed triple type R inlets
37	DP35,DP36,C3	23.3	40.6	total flow to pond 3, not rouled
38	Pond 2 out, Pond 3 out	12.7	37.9	proposed manhole
39	D1	18.5	34.9	proposed 2-16" D-10-R inlets
40a	D2(25%)	7.9	15.1	split w/DP40a flows, proposed 12" D-10-R inlet
40b	D2(50%)	7.9	15.1	split w/DP40a flows, proposed 12" D-10-R inlet
40c	D2(25%)	12.3	23.4	proposed 2-12" D-10-R inlets
41	DP39,DP40a,DP40b,DP40c,DP40d	48.0	92.0	total flow to pond 4 (south side)
42	D3	2.6	5.4	split with DP43 flows, proposed 4" D-10-R inlet
43	D4	1.3	2.1	split with DP42 flows, proposed 4" D-10-R inlet
44	DP42,DP43,DP45(50%)	5.2	10.9	total flow to pond 4 (south side)
45	DP38, Pond 4 out	28.8	77.3	proposed manhole
46	E	9.3	17.4	proposed 16" D-10-R inlet
47	Pond 5 outfall	2.1	5.5	total flow release
48	Pond 1 out,C5	119.9	238.3	Misty Ac 1 Pond Attenuation of Q10-58cfs, Q100=130cfs (per MDDP), yields Q10out=49.2cfs and Q100=108.3cfs
49	O6	1.0	2.7	proposed type C inlet
50	O7A	92.1	191.4	total flow to existing pond, no peak flow attenuation
51	DP50,O7B	110.5	227.6	existing dual 48" CMP culverts
52	DP51	102.6	211.3	low point collection structure, size TBD in FDR
53	O8	4.7	8.0	ex culvert, size unlk
54	DP45,DP47,DP48,DP49,DP52,DP53,DP54	212.2	436.4	total inflow
55	DP54 Pipe Out	212.2	436.4	existing 48" culvert outfall, add 2-48" RCP's
56	O10	40.8	113.3	existing 48" CMP culvert
57	DP56,O11	47.7	124.4	existing type C inlet
58	DP57,O12	51.7	133.3	existing 48" RCP culvert
59	DP58,O13	59.3	147.5	existing 48" RCP culvert

Pipe Summary			
Pipe ID	Flow (cfs)		Pipe Diam (in)
	Q ₁₀	Q ₁₀₀	
1A	5.8	17.2	30" RCP
1B	5.8	17.2	30" RCP
1C	5.8	17.2	30" RCP
1D	5.8	17.2	30" RCP
1E	6.0	9.6	18" RCP
2	22.0	35.4	30" RCP
3	9.0	15.0	24" RCP
4	31.0	50.4	36" RCP
5	5.7	9.7	18" RCP
6	5.7	9.7	18" RCP
7	36.7	60.0	36" RCP
8	7.1	20.7	18" RCP
9			NOT USED
10			NOT USED
11	9.4	15.3	24" RCP
12	18.7	30.6	24" RCP
13A	7.3	12.3	24" RCP
13B	14.6	24.7	30" RCP
14	7.3	12.3	24" RCP
15	11.8	19.6	24" RCP
16	7.5	12.2	24" RCP
17	19.3	31.8	30" RCP
18	26.6	44.1	36" RCP
19	5.4	9.5	24" RCP
20	10.9	18.9	24" RCP
21	42.8	71.4	42" RCP
22	69.2	115.5	42" RCP
23	1.0	1.8	18" RCP
24	1.9	3.5	18" RCP
25	2.9	5.3	18" RCP
26	7.5	12.8	24" RCP
27	10.3	18.1	24" RCP
28	15.4	27.9	24" RCP
29	16.6	33.3	24" RCP
30	12.2	21.9	30" RCP
31	22.1	38.3	36" RCP
32	2.1	5.6	18" RCP
33	12.7	33.9	36" RCP
34	12.7	33.9	36" RCP
35	9.2	17.5	24" RCP
36	18.5	34.9	30" RCP
37A	7.9	15.1	24" RCP
37B	15.9	30.2	30" RCP
37C	6.2	11.7	18" RCP
37D	22.0	42.0	30" RCP
38	28.2	53.7	36" RCP
39	2.6	5.4	18" RCP
40	3.8	7.5	24" RCP
41	16.1	30.4	36" RCP
42	28.8	73.3	42" RCP
43	9.3	17.4	24" RCP
44	2.1	5.5	18" RCP
45	60.9	108.3	54" RCP
46	61.9	111.0	54" RCP
47	61.9	111.0	54" RCP
48	164.5	322.3	78" RCP
49	164.5	322.3	78" RCP

Unresolved: Address the downstream easements that will be needed for construction and additional conveyance

SHEET NOTE:
 1. ALL ROADS SHOWN ON THIS MAP ARE PUBLIC.
 2. ALL STORM SEWER INFRASTRUCTURE LOCATED ON PRIVATE PROPERTY IS PRIVATE, WHILE ALL LOCATED WITHIN PUBLIC RIGHT OF WAY IS PUBLIC.

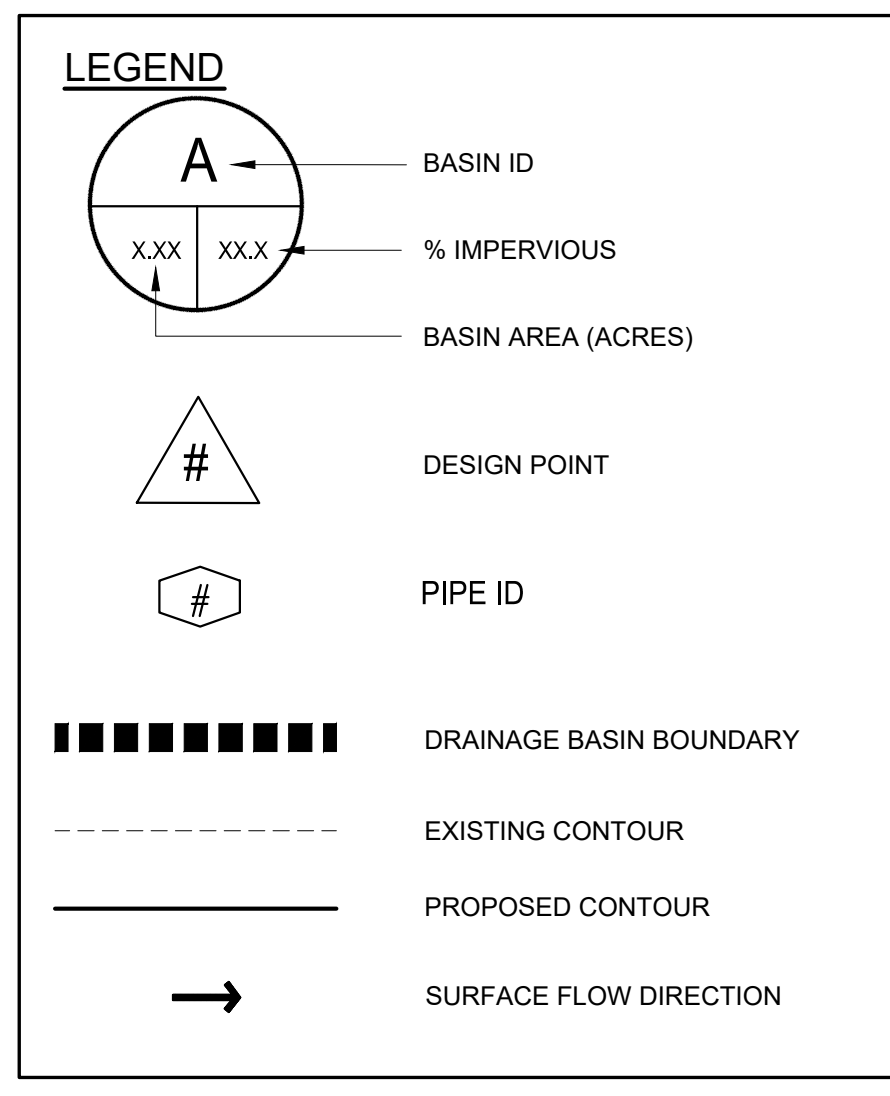

GENERAL NOTES
 1. EXISTING TOPOGRAPHY PROVIDED BY BEAR CREEK SURVEYING VIA AERIAL PHOTOGRAPHY.
 2. CONTOURS SHOWN ON THIS MAP REFLECT A 2' CONTOUR INTERVAL.
 3. AERIAL IMAGERY NOT SHOWN FOR CLARITY.

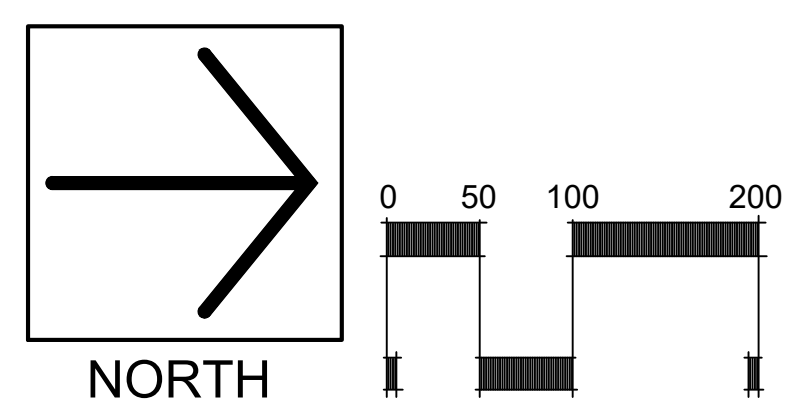

PRC ENGINEERS
 4400 S. PARKWAY DRIVE, SUITE 400A
 COLORADO SPRINGS, CO 80907

PRC
 ENGINEERING

MONUMENT RIDGE EAST
 TOWN OF MONUMENT
 EL PASO COUNTY, COLORADO

DRAINAGE PLAN
 DEVELOPED CONDITIONS - NORTH

Issued: 8/4/24

D4
 sheet number