

# MONUMENT RIDGE EAST

## EL PASO COUNTY, COLORADO

LOCATED IN THE NORTH ONE-HALF OF SECTION 2, T 11 S, R 67 W OF THE 6th P.M.

CURVE TABLE FOR LOTS 38-59		
CURVE	LENGTH	RADIUS
C40	46.86	225.00
C41	46.86	225.00
C42	41.82	225.00
C43	16.70	602.00
C44	12.18	173.00
C45	33.63	173.00
C46	8.64	173.00
C47	26.22	225.00

LOT AREA TABLE		
LOT	SQ FT	ACRES
36	29258.83	0.67
37	23686.04	0.54
38	22207.79	0.51
39	30748.61	0.71
40	26674.66	0.61
41	21330.92	0.49
42	32163.26	0.74
43	30410.57	0.70
44	27463.50	0.63
45	17514.39	0.40
46	12642.00	0.29
47	12177.50	0.28
48	65790.00	1.51
49	48406.48	1.11
50	6150.00	0.14
51	8491.50	0.20
52	69809.00	1.60
53	13650.03	0.31
54	25865.81	0.59
55	39000.00	0.90
56	32175.00	0.74
57	32175.00	0.74
58	55093.90	1.27
59	24374.91	0.56

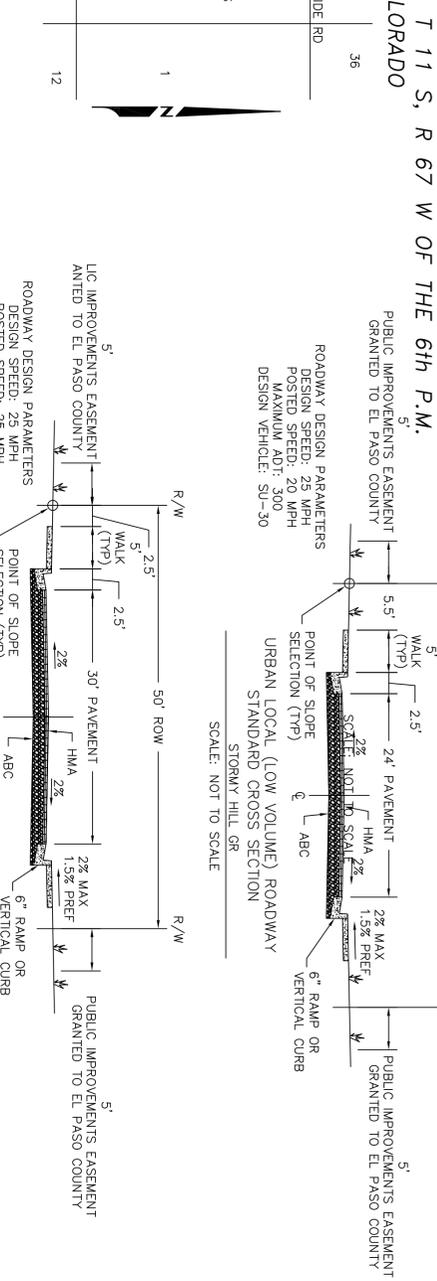

TRACT USE TABLE		
TRACT	USE	OWNERSHIP & MAINTENANCE
A	DRAINAGE/UTILITY	METROPOLITAN DISTRICT
B	DRAINAGE/UTILITY	METROPOLITAN DISTRICT
C	DRAINAGE/UTILITY	METROPOLITAN DISTRICT
D	DRAINAGE/UTILITY	METROPOLITAN DISTRICT
E	UTILITY/OPEN SPACE	METROPOLITAN DISTRICT
F	UTILITY/OPEN SPACE	METROPOLITAN DISTRICT
G	DRAINAGE/UTILITY	METROPOLITAN DISTRICT
H	UTILITY/OPEN SPACE	METROPOLITAN DISTRICT
J	UTILITY/OPEN SPACE	METROPOLITAN DISTRICT
K	UTILITY/STREET	METROPOLITAN DISTRICT
L	UTILITY/STREET	METROPOLITAN DISTRICT
M	DRAINAGE/UTILITY	METROPOLITAN DISTRICT
N	PARKING/UTILITY	METROPOLITAN DISTRICT
O	PARKING/UTILITY	METROPOLITAN DISTRICT
P	PARKING/UTILITY	METROPOLITAN DISTRICT

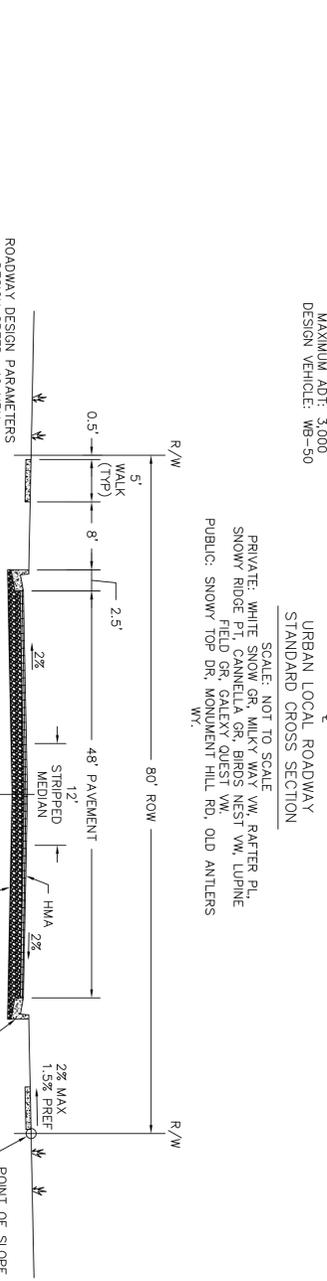

**LEGAL DESCRIPTION CONTINUED**

PARCEL E-2:

AN EASEMENT FOR INGRESS, EGRESS AND UTILITIES AS DESCRIBED IN DEED RECORDED DECEMBER 5, 1989 IN BOOK 5691 AT PAGE 1415 AND RE-RECORDED NOVEMBER 8, 1991 IN BOOK 5901 AT PAGE 177 AND RE-RECORDED JANUARY 14, 1992 IN BOOK 5924 AT PAGE 316 CONTAINING 0.00 ACRES (EASEMENT BENEFITING PARCEL E-1 ONLY).

**LEGAL DESCRIPTION CONTINUED**

PARCEL E-3:

A TRACT OF LAND LOCATED IN THE NORTH ONE HALF OF SECTION 2, TOWNSHIP 11 SOUTH, RANGE 67 WEST OF THE 6TH PRINCIPAL MERIDIAN, EL PASO COUNTY, COLORADO, MORE PARTICULARLY DESCRIBED AS FOLLOWS: BEGINNING AT A POINT OF INTERSECTION OF SAID SECTION, TH S 89 DEGREES 06 MINUTES 54 SECONDS WA DISTANCE OF 1320.00 FEET; THENCE S 00 DEGREES 06 MINUTES 12 SECONDS WA DISTANCE OF 887.45 FEET; FOR THE TRIANGLE POINT OF BEGINNING OF THE PARCEL TO BE DESCRIBED HEREBY; THENCE CONTINUE S 14 DEGREES 12 MINUTES 38 SECONDS WA DISTANCE OF 1024.53 FEET; THENCE S 86 DEGREES 45 MINUTES 14 SECONDS WA DISTANCE OF 236.90 FEET; THENCE S 89 DEGREES 54 MINUTES 09 SECONDS WA DISTANCE OF 236.90 FEET; THENCE S 89 DEGREES 54 MINUTES 09 SECONDS WA DISTANCE OF 649.40 FEET TO A POINT ON THE EASTERLY RIGHT-OF-WAY LINE OF INTERSTATE HIGHWAY 25; THENCE N 06 DEGREES 43 MINUTES 00 SECONDS E, ALONG SAID RIGHT-OF-WAY LINE, 666.56 FEET; THENCE S 89 DEGREES 57 MINUTES 36 SECONDS EA DISTANCE OF 251.71 FEET; THENCE S 06 DEGREES 43 MINUTES 00 SECONDS EA DISTANCE OF 337.99 FEET; THENCE S 89 DEGREES 57 MINUTES 36 SECONDS EA DISTANCE OF 732.00 FEET TO THE POINT OF BEGINNING CONTAINING 8.00 ACRES MORE OR LESS.

**LEGAL DESCRIPTION CONTINUED**

PARCEL E-4:

A TRACT OF LAND BEING A PORTION OF SECTION 2, TOWNSHIP 11 SOUTH, RANGE 67 WEST OF THE 6TH PRINCIPAL MERIDIAN, ALSO BEING A PORTION OF PARCEL A AND PARCEL B, AS DESCRIBED BY DOCUMENT (RECEPTION NO. 99035205, EL PASO COUNTY, COLORADO RECORDS), SITUATE IN COUNTY OF EL PASO, STATE OF COLORADO, DESCRIBED AS FOLLOWS: BEGINNING AT THE SOUTHWEST CORNER OF PARCEL A (ALL BEARINGS IN THIS DESCRIPTION ARE RELATIVE TO A PORTION OF THE WESTERLY LINE OF SAID PARCEL A, MONUMENTED AS SHOWN AND ASSUMED TO BEAR NORTH 01 DEGREES 04 MINUTES 39 SECONDS EAST, A DISTANCE OF 1833.20 FEET). (THE FOLLOWING SIX (6) COURSES ARE ALONG THE LINES OF SAID PARCEL A AND PARCEL B): 1) NORTH 01 DEGREES 04 MINUTES 39 SECONDS EAST, 1833.20 FEET; 2) NORTH 00 DEGREES 39 SECONDS EAST, 443.01 FEET; 4) NORTH 89 DEGREES 06 MINUTES 35 SECONDS WEST, 395.12 FEET; 5) NORTH 07 DEGREES 27 MINUTES 28 SECONDS EAST, 1273.57 FEET TO THE NORTHWEST CORNER OF SAID PARCEL B; 6) SOUTH 89 DEGREES 15 MINUTES 42 SECONDS EAST, 437.24 FEET TO THE NORTHWEST CORNER OF MISTY ACRES SUBDIVISION FILING NO. 1 (RECEPTION NO. 20519028), SAID EL PASO COUNTY RECORDS). (THE FOLLOWING FOURTEEN (14) COURSES ARE ALONG THE WESTERLY LINES OF SAID PARCEL 1) SOUTH 00 DEGREES 46 MINUTES 32 SECONDS WEST, 1.6 DEGREE 13 MINUTES 25 SECONDS LEFT CURVE RADIUS OF 601.00 FEET, AN ARC LENGTH OF 171.93 FEET; 2) SOUTH 15 DEGREES 34 MINUTES 30 SECONDS EAST, 647.10 FEET; 4) ON A CURVE, TO THE RIGHT, SAID CURVE HAVING A CENTRAL ANGLE OF 29 DEGREES 05 MINUTES 22 SECONDS, A RADIUS OF 521.00 FEET, AN ARC LENGTH OF 284.52 FEET; 5) SOUTH 13 DEGREES 30 MINUTES 52 SECONDS WEST, 382.56 FEET; 6) AN A CURVE TO THE RIGHT, SAID CURVE HAVING A CENTRAL ANGLE OF 29 DEGREES 13 MINUTES 34 SECONDS, A RADIUS OF 650.71 FEET, AN ARC LENGTH OF 331.92 FEET TO A POINT OF REVERSE CURVE; 7) AN

**LEGAL DESCRIPTION CONTINUED**

PARCEL E-5:

SAID REVERSE CURVE TO THE LEFT HAVING A CENTRAL ANGLE OF 41 DEGREES 42 MINUTES 48 SECONDS, A RADIUS OF 548.00 FEET, AN ARC LENGTH OF 399.66 FEET; 8) SOUTH 01 DEGREES 01 MINUTES 38 SECONDS WEST, 172.86 FEET; 9) ON A CURVE TO THE LEFT, SAID CURVE HAVING A CENTRAL ANGLE OF 25 DEGREES 14 MINUTES 35 SECONDS, A RADIUS OF 740.00 FEET, AN ARC LENGTH OF 326.03 FEET; 10) SOUTH 24 DEGREES 12 MINUTES 57 SECONDS EAST, 63 DEGREES 38 MINUTES 53 SECONDS, A RADIUS OF 521.00 FEET, AN ARC LENGTH OF 578.76 FEET; 11) ON A CURVE TO THE RIGHT, SAID CURVE HAVING A CENTRAL ANGLE OF 17 DEGREES 26 MINUTES 58 SECONDS, A RADIUS OF 601.00 FEET, AN ARC LENGTH OF 183.08 FEET; 14) SOUTH 21 DEGREES 58 MINUTES 58 SECONDS WEST, 91.58 FEET TO A POINT ON THE SOUTHERLY LINE OF SAID PARCEL A; THENCE NORTH 91 DEGREES 35 MINUTES 50 SECONDS WEST ALONG SAID PARCEL A; THENCE SOUTHERLY LINE, 64+39 FEET TO THE POINT OF BEGINNING CONTAINING 21.74 ACRES MORE OR LESS.

**LEGAL DESCRIPTION CONTINUED**

PARCEL E-1:

A TRACT OF LAND IN THE NORTH ONE-HALF OF SECTION 2, TOWNSHIP 11 SOUTH, RANGE 67 WEST OF THE 6TH PRINCIPAL MERIDIAN, EL PASO COUNTY, COLORADO, MORE PARTICULARLY DESCRIBED AS FOLLOWS: COMMENCING AT THE POINT OF INTERSECTION OF THE SOUTHERLY RIGHT-OF-WAY LINE OF 60 FOOT WIDE COUNTY LINE ROAD AND THE WESTERLY RIGHT-OF-WAY LINE OF 60 FOOT WIDE DOWNDOWN DRIVE AS DEDICATED IN "HEIGHTS FILING TWO" AS RECORDED IN PLAT BOOK E-5 AT PAGE 228 UNDER RECEPTION NO. 2287623 OF THE RECORDS OF EL PASO COUNTY, COLORADO, SAID POINT BEING ALSO THE NORTHEAST CORNER OF THAT RIGHT-OF-WAY PARCEL FOR COUNTY LINE ROAD GRANTED IN SPECIAL WARRANTY DEED RECORDED UNDER RECEPTION NO. 214002145 OF THE RECORDS OF EL PASO COUNTY, COLORADO; THENCE S 00° 02' 24" W, ALONG THE EASTERLY LINE THEREOF; 20.00 FEET TO THE POINT OF BEGINNING; THENCE CONTINUE S 00° 02' 24" W, ALONG THE WESTERLY RIGHT-OF-WAY LINE SAID DOWNDOWN DRIVE, 250.05 FEET TO THE WALKWAY AND NORTHERLY LINE, 204.72 FEET TO THE NORTHEAST CORNER OF SAID PARCEL; THENCE S 15° 04' 41" W, ALONG THE WESTERLY LINE OF SAID "HEIGHTS FILING TWO", 981.29 FEET TO THE NORTHEAST CORNER OF "HEIGHTS FILING ONE"; AS RECORDED IN PLAT BOOK E-5 AT PAGE 167 UNDER RECEPTION OF "HEIGHTS FILING ONE"; AS RECORDED IN EL PASO COUNTY, COLORADO; THENCE S 89° 45' 14" W, ALONG THE NORTHERLY LINE THEREOF; 306.89 FEET TO A POINT ON THE EASTERLY LINE OF THAT TRACT OF LAND DESCRIBED IN BOOK 3951 AT PAGE 1433 OF THE RECORDS OF EL PASO COUNTY, COLORADO AND AN EASTERLY LINE OF THAT TRACT OF LAND DESCRIBED IN PUBLIC TRUSTEES DEED RECORDED IN BOOK 5652 AT PAGE 323 OF THE RECORDS OF EL PASO COUNTY, COLORADO; THENCE N 14° 12' 38" E, ALONG SAID EASTERLY LINES, 102.54 FEET TO THE NORTHEASTLY CORNER OF THAT TRACT OF LAND DESCRIBED IN BOOK 3951 AT PAGE 1433 OF THE RECORDS OF EL PASO COUNTY, COLORADO; THENCE N 89° 57' 36" W, ALONG THE NORTHERLY LINE SAID DOWNDOWN DRIVE, 250.05 FEET TO THE NORTHEAST CORNER OF THAT TRACT OF LAND DESCRIBED IN BOOK 6488 AT PAGE 243 OF THE RECORDS OF EL PASO COUNTY, COLORADO; THENCE N 89° 57' 36" W, ALONG THE NORTHERLY LINE SAID DOWNDOWN DRIVE, 250.05 FEET TO THE NORTHEAST CORNER OF THAT TRACT OF LAND DESCRIBED IN BOOK 6488 AT PAGE 243 OF THE RECORDS OF EL PASO COUNTY, COLORADO; THE FOLLOWING TWO COURSES ARE ALONG THE BOUNDARY OF SAID TRACT: THENCE (1) N 06° 43' 00" E, 337.98 FEET; THENCE (2) N 89° 57' 36" W, 251.71 FEET TO A POINT ON THE EASTERLY LINE OF THAT TRACT OF LAND DESCRIBED IN DEED TO THE DEPARTMENT OF HIGHWAYS, STATE OF COLORADO RECORDED IN BOOK 1984 AT PAGE 836 OF THE RECORDS OF EL PASO COUNTY, COLORADO; THE FOLLOWING FOUR COURSES ARE ALONG SAID EASTERLY LINE: THENCE (1) N 06° 43' 00" E, 36.92 FEET; THENCE (2) N 29° 16' 30" E, 675.30 FEET; THENCE (3) N 89° 05' 00" E, 500.00 FEET; THENCE (4) N 29° 33' 00" E (BASIS OF BEARING), 180.19 FEET TO INTERSECT THE SOUTH LINE OF AFRESAD 60 FOOT WIDE COUNTY LINE ROAD; THENCE N 89° 06' 54" E, ALONG SAID SOUTHERLY LINE 288.85 FEET TO THE NORTHWEST CORNER OF THE AFRESAD RIGHT-OF-WAY PARCEL GRANTED TO EL PASO COUNTY, COLORADO UNDER RECEPTION NO. 214002145 OF THE RECORDS OF EL PASO COUNTY, COLORADO; THENCE S 89° 06' 54" E, ALONG THE WESTERLY LINE OF SAID PARCEL, 288.85 FEET TO THE POINT OF BEGINNING OF SAID TRACT; THENCE (1) S 00° 53' 11" E, 11.00 FEET; ALONG THE SOUTHERLY LINE THEREOF; THENCE (2) S 89° 46' 13" E, 87.26 FEET; THENCE (3) S 89° 57' 43" E, 186.01 FEET; THENCE (4) S 89° 57' 43" E, 154.69 FEET TO THE POINT OF BEGINNING; EXCEPTING THEREFROM THAT PARCEL, CONVEYED TO WOODMOOR WATER AND SANITATION DISTRICT FOR THE CRYSTAL CREEK LIFT STATION, BY DEED RECORDED NOVEMBER 30, 1998 AT RECEPTION NO. 98175218 OF THE RECORDS OF EL PASO COUNTY, COLORADO; EXCEPTING DEED RECORDED NOVEMBER 29, 2010 AT RECEPTION NO. 210120918 AND JANUARY 9, 2014 AT RECEPTION NO. 214002145 AND FURTHER EXCEPTING ANY PORTION WITHIN THE RIGHT-OF-WAY OF COUNTY LINE ROAD OR INTERSTATE HIGHWAY 25, AND FURTHER EXCEPTING THAT PORTION LINE DEDICATED AS DOWNDOWN DRIVE IN "HEIGHTS FILING TWO" AS RECORDED IN PLAT BOOK E-5 UNDER RECEPTION NO. 2287623 OF THE RECORDS OF EL PASO COUNTY, COLORADO, CONTAINING 29.19 ACRES MORE OR LESS.

**LEGAL DESCRIPTION CONTINUED**

PARCEL E-2:

AN EASEMENT FOR INGRESS, EGRESS AND UTILITIES AS DESCRIBED IN DEED RECORDED DECEMBER 5, 1989 IN BOOK 5691 AT PAGE 1415 AND RE-RECORDED NOVEMBER 8, 1991 IN BOOK 5901 AT PAGE 177 AND RE-RECORDED JANUARY 14, 1992 IN BOOK 5924 AT PAGE 316 CONTAINING 0.00 ACRES (EASEMENT BENEFITING PARCEL E-1 ONLY).

**LEGAL DESCRIPTION CONTINUED**

PARCEL E-3:

A TRACT OF LAND LOCATED IN THE NORTH ONE HALF OF SECTION 2, TOWNSHIP 11 SOUTH, RANGE 67 WEST OF THE 6TH PRINCIPAL MERIDIAN, EL PASO COUNTY, COLORADO, MORE PARTICULARLY DESCRIBED AS FOLLOWS: BEGINNING AT A POINT OF INTERSECTION OF SAID SECTION, TH S 89 DEGREES 06 MINUTES 54 SECONDS WA DISTANCE OF 1320.00 FEET; THENCE S 00 DEGREES 06 MINUTES 12 SECONDS WA DISTANCE OF 887.45 FEET; FOR THE TRIANGLE POINT OF BEGINNING OF THE PARCEL TO BE DESCRIBED HEREBY; THENCE CONTINUE S 14 DEGREES 12 MINUTES 38 SECONDS WA DISTANCE OF 1024.53 FEET; THENCE S 86 DEGREES 45 MINUTES 14 SECONDS WA DISTANCE OF 236.90 FEET; THENCE S 89 DEGREES 54 MINUTES 09 SECONDS WA DISTANCE OF 236.90 FEET; THENCE S 89 DEGREES 54 MINUTES 09 SECONDS WA DISTANCE OF 649.40 FEET TO A POINT ON THE EASTERLY RIGHT-OF-WAY LINE OF INTERSTATE HIGHWAY 25; THENCE N 06 DEGREES 43 MINUTES 00 SECONDS E, ALONG SAID RIGHT-OF-WAY LINE, 666.56 FEET; THENCE S 89 DEGREES 57 MINUTES 36 SECONDS EA DISTANCE OF 251.71 FEET; THENCE S 06 DEGREES 43 MINUTES 00 SECONDS EA DISTANCE OF 337.99 FEET; THENCE S 89 DEGREES 57 MINUTES 36 SECONDS EA DISTANCE OF 732.00 FEET TO THE POINT OF BEGINNING CONTAINING 8.00 ACRES MORE OR LESS.

**LEGAL DESCRIPTION CONTINUED**

PARCEL E-4:

A TRACT OF LAND BEING A PORTION OF SECTION 2, TOWNSHIP 11 SOUTH, RANGE 67 WEST OF THE 6TH PRINCIPAL MERIDIAN, ALSO BEING A PORTION OF PARCEL A AND PARCEL B, AS DESCRIBED BY DOCUMENT (RECEPTION NO. 99035205, EL PASO COUNTY, COLORADO RECORDS), SITUATE IN COUNTY OF EL PASO, STATE OF COLORADO, DESCRIBED AS FOLLOWS: BEGINNING AT THE SOUTHWEST CORNER OF PARCEL A (ALL BEARINGS IN THIS DESCRIPTION ARE RELATIVE TO A PORTION OF THE WESTERLY LINE OF SAID PARCEL A, MONUMENTED AS SHOWN AND ASSUMED TO BEAR NORTH 01 DEGREES 04 MINUTES 39 SECONDS EAST, A DISTANCE OF 1833.20 FEET). (THE FOLLOWING SIX (6) COURSES ARE ALONG THE LINES OF SAID PARCEL A AND PARCEL B): 1) NORTH 01 DEGREES 04 MINUTES 39 SECONDS EAST, 1833.20 FEET; 2) NORTH 00 DEGREES 39 SECONDS EAST, 443.01 FEET; 4) NORTH 89 DEGREES 06 MINUTES 35 SECONDS WEST, 395.12 FEET; 5) NORTH 07 DEGREES 27 MINUTES 28 SECONDS EAST, 1273.57 FEET TO THE NORTHWEST CORNER OF SAID PARCEL B; 6) SOUTH 89 DEGREES 15 MINUTES 42 SECONDS EAST, 437.24 FEET TO THE NORTHWEST CORNER OF MISTY ACRES SUBDIVISION FILING NO. 1 (RECEPTION NO. 20519028), SAID EL PASO COUNTY RECORDS). (THE FOLLOWING FOURTEEN (14) COURSES ARE ALONG THE WESTERLY LINES OF SAID PARCEL 1) SOUTH 00 DEGREES 46 MINUTES 32 SECONDS WEST, 1.6 DEGREE 13 MINUTES 25 SECONDS LEFT CURVE RADIUS OF 601.00 FEET, AN ARC LENGTH OF 171.93 FEET; 2) SOUTH 15 DEGREES 34 MINUTES 30 SECONDS EAST, 647.10 FEET; 4) ON A CURVE, TO THE RIGHT, SAID CURVE HAVING A CENTRAL ANGLE OF 29 DEGREES 05 MINUTES 22 SECONDS, A RADIUS OF 521.00 FEET, AN ARC LENGTH OF 284.52 FEET; 5) SOUTH 13 DEGREES 30 MINUTES 52 SECONDS WEST, 382.56 FEET; 6) AN A CURVE TO THE RIGHT, SAID CURVE HAVING A CENTRAL ANGLE OF 29 DEGREES 13 MINUTES 34 SECONDS, A RADIUS OF 650.71 FEET, AN ARC LENGTH OF 331.92 FEET TO A POINT OF REVERSE CURVE; 7) AN

**LEGAL DESCRIPTION CONTINUED**

PARCEL E-1:

A TRACT OF LAND IN THE NORTH ONE-HALF OF SECTION 2, TOWNSHIP 11 SOUTH, RANGE 67 WEST OF THE 6TH PRINCIPAL MERIDIAN, EL PASO COUNTY, COLORADO, MORE PARTICULARLY DESCRIBED AS FOLLOWS: COMMENCING AT THE POINT OF INTERSECTION OF THE SOUTHERLY RIGHT-OF-WAY LINE OF 60 FOOT WIDE COUNTY LINE ROAD AND THE WESTERLY RIGHT-OF-WAY LINE OF 60 FOOT WIDE DOWNDOWN DRIVE AS DEDICATED IN "HEIGHTS FILING TWO" AS RECORDED IN PLAT BOOK E-5 AT PAGE 228 UNDER RECEPTION NO. 2287623 OF THE RECORDS OF EL PASO COUNTY, COLORADO, SAID POINT BEING ALSO THE NORTHEAST CORNER OF THAT RIGHT-OF-WAY PARCEL FOR COUNTY LINE ROAD GRANTED IN SPECIAL WARRANTY DEED RECORDED UNDER RECEPTION NO. 214002145 OF THE RECORDS OF EL PASO COUNTY, COLORADO; THENCE S 00° 02' 24" W, ALONG THE EASTERLY LINE THEREOF; 20.00 FEET TO THE POINT OF BEGINNING; THENCE CONTINUE S 00° 02' 24" W, ALONG THE WESTERLY RIGHT-OF-WAY LINE SAID DOWNDOWN DRIVE, 250.05 FEET TO THE WALKWAY AND NORTHERLY LINE, 204.72 FEET TO THE NORTHEAST CORNER OF SAID PARCEL; THENCE S 15° 04' 41" W, ALONG THE WESTERLY LINE OF SAID "HEIGHTS FILING TWO", 981.29 FEET TO THE NORTHEAST CORNER OF "HEIGHTS FILING ONE"; AS RECORDED IN PLAT BOOK E-5 AT PAGE 167 UNDER RECEPTION OF "HEIGHTS FILING ONE"; AS RECORDED IN EL PASO COUNTY, COLORADO; THENCE S 89° 45' 14" W, ALONG THE NORTHERLY LINE THEREOF; 306.89 FEET TO A POINT ON THE EASTERLY LINE OF THAT TRACT OF LAND DESCRIBED IN BOOK 3951 AT PAGE 1433 OF THE RECORDS OF EL PASO COUNTY, COLORADO AND AN EASTERLY LINE OF THAT TRACT OF LAND DESCRIBED IN PUBLIC TRUSTEES DEED RECORDED IN BOOK 5652 AT PAGE 323 OF THE RECORDS OF EL PASO COUNTY, COLORADO; THENCE N 14° 12' 38" E, ALONG SAID EASTERLY LINES, 102.54 FEET TO THE NORTHEASTLY CORNER OF THAT TRACT OF LAND DESCRIBED IN BOOK 3951 AT PAGE 1433 OF THE RECORDS OF EL PASO COUNTY, COLORADO; THENCE N 89° 57' 36" W, ALONG THE NORTHERLY LINE SAID DOWNDOWN DRIVE, 250.05 FEET TO THE NORTHEAST CORNER OF THAT TRACT OF LAND DESCRIBED IN BOOK 6488 AT PAGE 243 OF THE RECORDS OF EL PASO COUNTY, COLORADO; THENCE N 89° 57' 36" W, ALONG THE NORTHERLY LINE SAID DOWNDOWN DRIVE, 250.05 FEET TO THE NORTHEAST CORNER OF THAT TRACT OF LAND DESCRIBED IN BOOK 6488 AT PAGE 243 OF THE RECORDS OF EL PASO COUNTY, COLORADO; THE FOLLOWING TWO COURSES ARE ALONG THE BOUNDARY OF SAID TRACT: THENCE (1) N 06° 43' 00" E, 337.98 FEET; THENCE (2) N 89° 57' 36" W, 251.71 FEET TO A POINT ON THE EASTERLY LINE OF THAT TRACT OF LAND DESCRIBED IN DEED TO THE DEPARTMENT OF HIGHWAYS, STATE OF COLORADO RECORDED IN BOOK 1984 AT PAGE 836 OF THE RECORDS OF EL PASO COUNTY, COLORADO; THE FOLLOWING FOUR COURSES ARE ALONG SAID EASTERLY LINE: THENCE (1) N 06° 43' 00" E, 36.92 FEET; THENCE (2) N 29° 16' 30" E, 675.30 FEET; THENCE (3) N 89° 05' 00" E, 500.00 FEET; THENCE (4) N 29° 33' 00" E (BASIS OF BEARING), 180.19 FEET TO INTERSECT THE SOUTH LINE OF AFRESAD 60 FOOT WIDE COUNTY LINE ROAD; THENCE N 89° 06' 54" E, ALONG SAID SOUTHERLY LINE 288.85 FEET TO THE NORTHWEST CORNER OF THE AFRESAD RIGHT-OF-WAY PARCEL GRANTED TO EL PASO COUNTY, COLORADO UNDER RECEPTION NO. 214002145 OF THE RECORDS OF EL PASO COUNTY, COLORADO; THENCE S 89° 06' 54" E, ALONG THE WESTERLY LINE OF SAID PARCEL, 288.85 FEET TO THE POINT OF BEGINNING OF SAID TRACT; THENCE (1) S 00° 53' 11" E, 11.00 FEET; ALONG THE SOUTHERLY LINE THEREOF; THENCE (2) S 89° 46' 13" E, 87.26 FEET; THENCE (3) S 89° 57' 43" E, 186.01 FEET; THENCE (4) S 89° 57' 43" E, 154.69 FEET TO THE POINT OF BEGINNING; EXCEPTING THEREFROM THAT PARCEL, CONVEYED TO WOODMOOR WATER AND SANITATION DISTRICT FOR THE CRYSTAL CREEK LIFT STATION, BY DEED RECORDED NOVEMBER 30, 1998 AT RECEPTION NO. 98175218 OF THE RECORDS OF EL PASO COUNTY, COLORADO; EXCEPTING DEED RECORDED NOVEMBER 29, 2010 AT RECEPTION NO. 210120918 AND JANUARY 9, 2014 AT RECEPTION NO. 214002145 AND FURTHER EXCEPTING ANY PORTION WITHIN THE RIGHT-OF-WAY OF COUNTY LINE ROAD OR INTERSTATE HIGHWAY 25, AND FURTHER EXCEPTING THAT PORTION LINE DEDICATED AS DOWNDOWN DRIVE IN "HEIGHTS FILING TWO" AS RECORDED IN PLAT BOOK E-5 UNDER RECEPTION NO. 2287623 OF THE RECORDS OF EL PASO COUNTY, COLORADO, CONTAINING 29.19 ACRES MORE OR LESS.

**LEGAL DESCRIPTION CONTINUED**

PARCEL E-2:

AN EASEMENT FOR INGRESS, EGRESS AND UTILITIES AS DESCRIBED IN DEED RECORDED DECEMBER 5, 1989 IN BOOK 5691 AT PAGE 1415 AND RE-RECORDED NOVEMBER 8, 1991 IN BOOK 5901 AT PAGE 177 AND RE-RECORDED JANUARY 14, 1992 IN BOOK 5924 AT PAGE 316 CONTAINING 0.00 ACRES (EASEMENT BENEFITING PARCEL E-1 ONLY).

**LEGAL DESCRIPTION CONTINUED**

PARCEL E-3:

A TRACT OF LAND LOCATED IN THE NORTH ONE HALF OF SECTION 2, TOWNSHIP 11 SOUTH, RANGE 67 WEST OF THE 6TH PRINCIPAL MERIDIAN, EL PASO COUNTY, COLORADO, MORE PARTICULARLY DESCRIBED AS FOLLOWS: BEGINNING AT A POINT OF INTERSECTION OF SAID SECTION, TH S 89 DEGREES 06 MINUTES 54 SECONDS WA DISTANCE OF 1320.00 FEET; THENCE S 00 DEGREES 06 MINUTES 12 SECONDS WA DISTANCE OF 887.45 FEET; FOR THE TRIANGLE POINT OF BEGINNING OF THE PARCEL TO BE DESCRIBED HEREBY; THENCE CONTINUE S 14 DEGREES 12 MINUTES 38 SECONDS WA DISTANCE OF 1024.53 FEET; THENCE S 86 DEGREES 45 MINUTES 14 SECONDS WA DISTANCE OF 236.90 FEET; THENCE S 89 DEGREES 54 MINUTES 09 SECONDS WA DISTANCE OF 236.90 FEET; THENCE S 89 DEGREES 54 MINUTES 09 SECONDS WA DISTANCE OF 649.40 FEET TO A POINT ON THE EASTERLY RIGHT-OF-WAY LINE OF INTERSTATE HIGHWAY 25; THENCE N 06 DEGREES 43 MINUTES 00 SECONDS E, ALONG SAID RIGHT-OF-WAY LINE, 666.56 FEET; THENCE S 89 DEGREES 57 MINUTES 36 SECONDS EA DISTANCE OF 251.71 FEET; THENCE S 06 DEGREES 43 MINUTES 00 SECONDS EA DISTANCE OF 337.99 FEET; THENCE S 89 DEGREES 57 MINUTES 36 SECONDS EA DISTANCE OF 732.00 FEET TO THE POINT OF BEGINNING CONTAINING 8.00 ACRES MORE OR LESS.

**LEGAL DESCRIPTION CONTINUED**

PARCEL E-4:

A TRACT OF LAND BEING A PORTION OF SECTION 2, TOWNSHIP 11 SOUTH, RANGE 67 WEST OF THE 6TH PRINCIPAL MERIDIAN, ALSO BEING A PORTION OF PARCEL A AND PARCEL B, AS DESCRIBED BY DOCUMENT (RECEPTION NO. 99035205, EL PASO COUNTY, COLORADO RECORDS), SITUATE IN COUNTY OF EL PASO, STATE OF COLORADO, DESCRIBED AS FOLLOWS: BEGINNING AT THE SOUTHWEST CORNER OF PARCEL A (ALL BEARINGS IN THIS DESCRIPTION ARE RELATIVE TO A PORTION OF THE WESTERLY LINE OF SAID PARCEL A, MONUMENTED AS SHOWN AND ASSUMED TO BEAR NORTH 01 DEGREES 04 MINUTES 39 SECONDS EAST, A DISTANCE OF 1833.20 FEET). (THE FOLLOWING SIX (6) COURSES ARE ALONG THE LINES OF SAID PARCEL A AND PARCEL B): 1) NORTH 01 DEGREES 04 MINUTES 39 SECONDS EAST, 1833.20 FEET; 2) NORTH 00 DEGREES 39 SECONDS EAST, 443.01 FEET; 4) NORTH 89 DEGREES 06 MINUTES 35 SECONDS WEST, 395.12 FEET; 5) NORTH 07 DEGREES 27 MINUTES 28 SECONDS EAST, 1273.57 FEET TO THE NORTHWEST CORNER OF SAID PARCEL B; 6) SOUTH 89 DEGREES 15 MINUTES 42 SECONDS EAST, 437.24 FEET TO THE NORTHWEST CORNER OF MISTY ACRES SUBDIVISION FILING NO. 1 (RECEPTION NO. 20519028), SAID EL PASO COUNTY RECORDS). (THE FOLLOWING FOURTEEN (14) COURSES ARE ALONG THE WESTERLY LINES OF SAID PARCEL 1) SOUTH 00 DEGREES 46 MINUTES 32 SECONDS WEST, 1.6 DEGREE 13 MINUTES 25 SECONDS LEFT CURVE RADIUS OF 601.00 FEET, AN ARC LENGTH OF 171.93 FEET; 2) SOUTH 15 DEGREES 34 MINUTES 30 SECONDS EAST, 647.10 FEET; 4) ON A CURVE, TO THE RIGHT, SAID CURVE HAVING A CENTRAL ANGLE OF 29 DEGREES 05 MINUTES 22 SECONDS, A RADIUS OF 521.00 FEET, AN ARC LENGTH OF 284.52 FEET; 5) SOUTH 13 DEGREES 30 MINUTES 52 SECONDS WEST, 382.56 FEET; 6) AN A CURVE TO THE RIGHT, SAID CURVE HAVING A CENTRAL ANGLE OF 29 DEGREES 13 MINUTES 34 SECONDS, A RADIUS OF 650.71 FEET, AN ARC LENGTH OF 331.92 FEET TO A POINT OF REVERSE CURVE; 7) AN

**LEGAL DESCRIPTION CONTINUED**

PARCEL E-1:

A TRACT OF LAND IN THE NORTH ONE-HALF OF SECTION 2, TOWNSHIP 11 SOUTH, RANGE 67 WEST OF THE 6TH PRINCIPAL MERIDIAN, EL PASO COUNTY, COLORADO, MORE PARTICULARLY DESCRIBED AS FOLLOWS: COMMENCING AT THE POINT OF INTERSECTION OF THE SOUTHERLY RIGHT-OF-WAY LINE OF 60 FOOT WIDE COUNTY LINE ROAD AND THE WESTERLY RIGHT-OF-WAY LINE OF 60 FOOT WIDE DOWNDOWN DRIVE AS DEDICATED IN "HEIGHTS FILING TWO" AS RECORDED IN PLAT BOOK E-5 AT PAGE 228 UNDER RECEPTION NO. 2287623 OF THE RECORDS OF EL PASO COUNTY, COLORADO, SAID POINT BEING ALSO THE NORTHEAST CORNER OF THAT RIGHT-OF-WAY PARCEL FOR COUNTY LINE ROAD GRANTED IN SPECIAL WARRANTY DEED RECORDED UNDER RECEPTION NO. 214002145 OF THE RECORDS OF EL PASO COUNTY, COLORADO; THENCE S 00° 02' 24" W, ALONG THE EASTERLY LINE THEREOF; 20.00 FEET TO THE POINT OF BEGINNING; THENCE CONTINUE S 00° 02' 24" W, ALONG THE WESTERLY RIGHT-OF-WAY LINE SAID DOWNDOWN DRIVE, 250.05 FEET TO THE WALKWAY AND NORTHERLY LINE, 204.72 FEET TO THE NORTHEAST CORNER OF SAID PARCEL; THENCE S 15° 04' 41" W, ALONG THE WESTERLY LINE OF SAID "HEIGHTS FILING TWO", 981.29 FEET TO THE NORTHEAST CORNER OF "HEIGHTS FILING ONE"; AS RECORDED IN PLAT BOOK E-5 AT PAGE 167 UNDER RECEPTION OF "HEIGHTS FILING ONE"; AS RECORDED IN EL PASO COUNTY, COLORADO; THENCE S 89° 45' 14" W, ALONG THE NORTHERLY LINE THEREOF; 306.89 FEET TO A POINT ON THE EASTERLY LINE OF THAT TRACT OF LAND DESCRIBED IN BOOK 3951 AT PAGE 1433 OF THE RECORDS OF EL PASO COUNTY, COLORADO AND AN EASTERLY LINE OF THAT TRACT OF LAND DESCRIBED IN PUBLIC TRUSTEES DEED RECORDED IN BOOK 5652 AT PAGE 323 OF THE RECORDS OF EL PASO COUNTY, COLORADO; THENCE N 14° 12' 38" E, ALONG SAID EASTERLY LINES, 102.54 FEET TO THE NORTHEASTLY CORNER OF THAT TRACT OF LAND DESCRIBED IN BOOK 3951 AT PAGE 1433 OF THE RECORDS OF EL PASO COUNTY, COLORADO; THENCE N 89° 57' 36" W, ALONG THE NORTHERLY LINE SAID DOWNDOWN DRIVE, 250.05 FEET TO THE NORTHEAST CORNER OF THAT TRACT OF LAND DESCRIBED IN BOOK 6488 AT PAGE 243 OF THE RECORDS OF EL PASO COUNTY, COLORADO; THENCE N 89° 57' 36" W, ALONG THE NORTHERLY LINE SAID DOWNDOWN DRIVE, 250.05 FEET TO THE NORTHEAST CORNER OF THAT TRACT OF LAND DESCRIBED IN BOOK 6488 AT PAGE 243 OF THE RECORDS OF EL PASO COUNTY, COLORADO; THE FOLLOWING TWO COURSES ARE ALONG THE BOUNDARY OF SAID TRACT: THENCE (1) N 06° 43' 00" E, 337.98 FEET; THENCE (2) N 89° 57' 36" W, 251.71 FEET TO A POINT ON THE EASTERLY LINE OF THAT TRACT OF LAND DESCRIBED IN DEED TO THE DEPARTMENT OF HIGHWAYS, STATE OF COLORADO RECORDED IN BOOK 1984 AT PAGE 836 OF THE RECORDS OF EL PASO COUNTY, COLORADO; THE FOLLOWING FOUR COURSES ARE ALONG SAID EASTERLY LINE: THENCE (1) N 06° 43' 00" E, 36.92 FEET; THENCE (2) N 29° 16' 30" E, 675.30 FEET; THENCE (3) N 89° 05' 00" E, 500.00 FEET; THENCE (4) N 29° 33' 00" E (BASIS OF BEARING), 180.19 FEET TO INTERSECT THE SOUTH LINE OF AFRESAD 60 FOOT WIDE COUNTY LINE ROAD; THENCE N 89° 06' 54" E, ALONG SAID SOUTHERLY LINE 288.85 FEET TO THE NORTHWEST CORNER OF THE AFRESAD RIGHT-OF-WAY PARCEL GRANTED TO EL PASO COUNTY, COLORADO UNDER RECEPTION NO. 214002145 OF THE RECORDS OF EL PASO COUNTY, COLORADO; THENCE S 89° 06' 54" E, ALONG THE WESTERLY LINE OF SAID PARCEL, 288.85 FEET TO THE POINT OF BEGINNING OF SAID TRACT; THENCE (1) S 00° 53' 11" E, 11.00 FEET; ALONG THE SOUTHERLY LINE THEREOF; THENCE (2) S 89° 46' 13" E, 87.26 FEET; THENCE (3) S 89° 57' 43" E, 186.01 FEET; THENCE (4) S 89° 57' 43" E, 154.69 FEET TO THE POINT OF BEGINNING; EXCEPTING THEREFROM THAT PARCEL, CONVEYED TO WOODMOOR WATER AND SANITATION DISTRICT FOR THE CRYSTAL CREEK LIFT STATION, BY DEED RECORDED NOVEMBER 30, 1998 AT RECEPTION NO. 98175218 OF THE RECORDS OF EL PASO COUNTY, COLORADO; EXCEPTING DEED RECORDED NOVEMBER 29, 2010 AT RECEPTION NO. 210120918 AND JANUARY 9, 2014 AT RECEPTION NO. 214002145 AND FURTHER EXCEPTING ANY PORTION WITHIN THE RIGHT-OF-WAY OF COUNTY LINE ROAD OR INTERSTATE HIGHWAY 25, AND FURTHER EXCEPTING THAT PORTION

**MONUMENT RIDGE EAST**  
 LOCATED IN THE NORTH ONE-HALF OF SECTION 2, T 11 S, R 67 W OF THE 6TH P.M.  
 EL PASO COUNTY, COLORADO

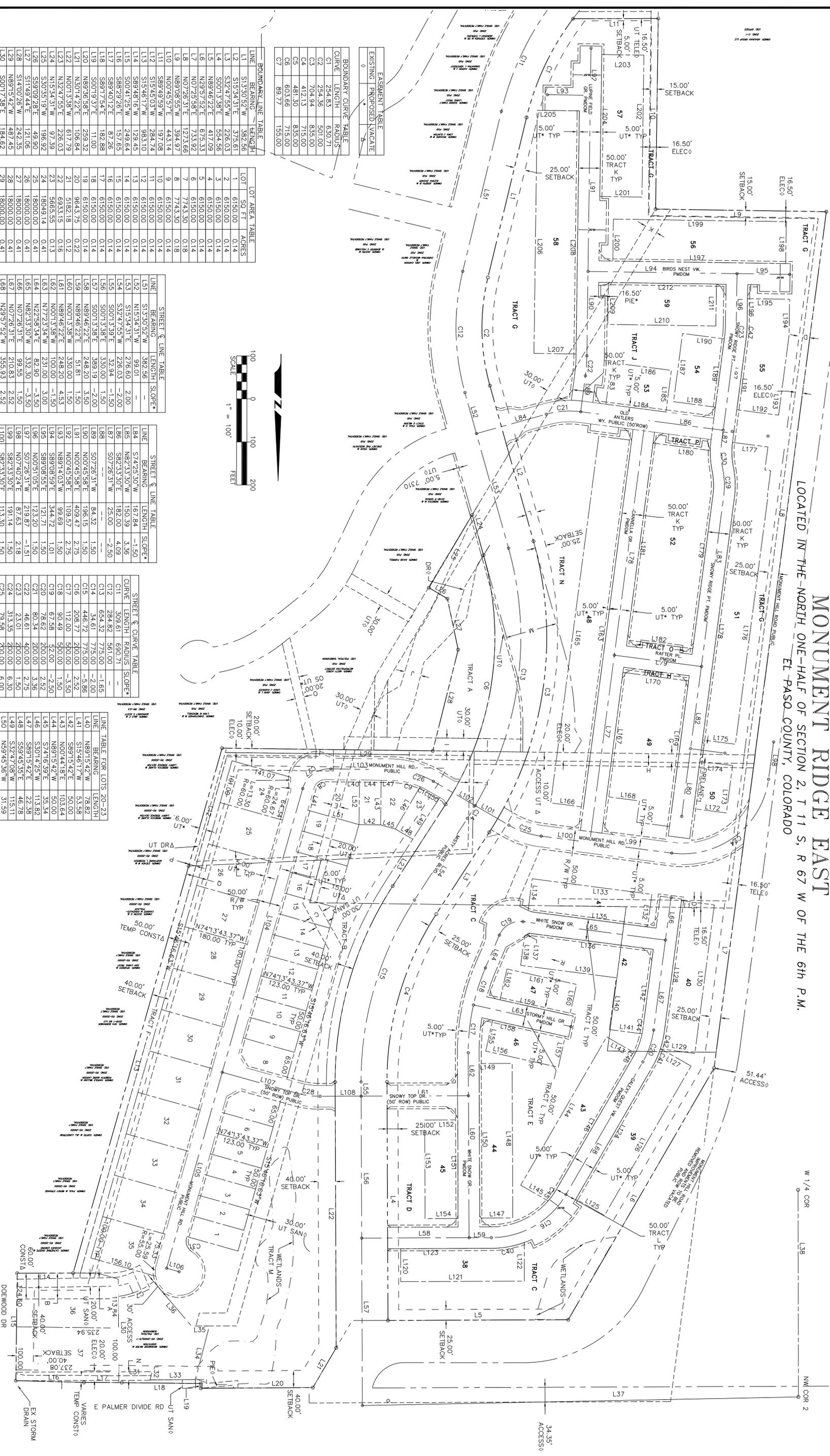

**EXISTING PROPOSED/VACATE**

LINE	BEARING	LENGTH
L1	S13°30'52"W	382.56
L2	S15°34'31"E	375.61
L3	S32°47'55"W	226.03
L4	S00°13'38"E	554.56
L5	N89°46'22"E	417.09
L6	N29°57'52"E	675.33
L7	N07°26'31"E	733.82
L8	N07°26'31"E	1273.69
L9	N89°08'55"W	354.97
L10	N07°26'31"E	443.14
L11	S89°49'59"W	197.09
L12	S13°30'52"W	284.74
L13	S13°30'52"W	988.10
L14	S89°46'18"W	129.64
L15	S07°41'25"W	249.64
L16	S89°29'26"E	157.65
L17	S89°40'12"E	87.26
L18	S89°17'54"E	182.88
L19	S07°19'31"E	11.00
L20	N89°56'58"E	259.32
L21	N20°14'22"E	106.84
L22	N00°13'58"W	617.79
L23	N24°47'55"E	226.03
L24	N15°34'31"W	97.39
L25	S30°35'19"W	196.92
L26	S59°09'28"E	49.90
L27	S11°49'44"E	121.96
L28	N14°00'26"W	242.35
L29	N89°15'42"W	487.45
L30	S00°17'38"E	184.62
L31	S89°42'21"W	74.90
L32	S12°23'28"W	10.26
L33	N89°42'21"E	104.86
L34	N14°32'38"E	128.71
L35	S89°35'16"W	41.27
L36	N44°01'32"W	135.79
L37	S89°35'16"W	41.27
L38	N44°01'32"W	135.79

**BOUNDARY CURVE TABLE**

LINE	BEARING	LENGTH	LOT SQ. FT.	ACRES
C1	254.83	630.71	1	6150.00
C2	254.83	630.71	2	6150.00
C3	704.94	835.00	3	6150.00
C4	412.13	715.00	4	6150.00
C5	481.30	835.00	5	6150.00
C6	603.66	715.00	6	6150.00
C7	89.77	155.00	7	6150.00

**LOT AREA TABLE**

LINE	BEARING	LENGTH	LOT SQ. FT.	ACRES
L1	S13°30'52"W	382.56	1	6150.00
L2	S15°34'31"E	375.61	2	6150.00
L3	S32°47'55"W	226.03	3	6150.00
L4	S00°13'38"E	554.56	4	6150.00
L5	N89°46'22"E	417.09	5	6150.00
L6	N29°57'52"E	675.33	6	6150.00
L7	N07°26'31"E	733.82	7	6150.00
L8	N07°26'31"E	1273.69	8	6150.00
L9	N89°08'55"W	354.97	9	6150.00
L10	N07°26'31"E	443.14	10	6150.00
L11	S89°49'59"W	197.09	11	6150.00
L12	S13°30'52"W	284.74	12	6150.00
L13	S13°30'52"W	988.10	13	6150.00
L14	S89°46'18"W	129.64	14	6150.00
L15	S07°41'25"W	249.64	15	6150.00
L16	S89°29'26"E	157.65	16	6150.00
L17	S89°40'12"E	87.26	17	6150.00
L18	S89°17'54"E	182.88	18	6150.00
L19	S07°19'31"E	11.00	19	6150.00
L20	N89°56'58"E	259.32	20	6150.00
L21	N20°14'22"E	106.84	21	6150.00
L22	N00°13'58"W	617.79	22	6150.00
L23	N24°47'55"E	226.03	23	6150.00
L24	N15°34'31"W	97.39	24	6150.00
L25	S30°35'19"W	196.92	25	6150.00
L26	S59°09'28"E	49.90	26	6150.00
L27	S11°49'44"E	121.96	27	6150.00
L28	N14°00'26"W	242.35	28	6150.00
L29	N89°15'42"W	487.45	29	6150.00
L30	S00°17'38"E	184.62	30	6150.00
L31	S89°42'21"W	74.90	31	6150.00
L32	S12°23'28"W	10.26	32	6150.00
L33	N89°42'21"E	104.86	33	6150.00
L34	N14°32'38"E	128.71	34	6150.00
L35	S89°35'16"W	41.27	35	6150.00
L36	N44°01'32"W	135.79	36	6150.00
L37	S89°35'16"W	41.27	37	6150.00
L38	N44°01'32"W	135.79	37	6150.00

**STREET & LINE TABLE**

LINE	BEARING	LENGTH	SLOPE*
L51	S13°30'52"W	382.56	-
L52	N13°34'31"E	391.01	2.00
L53	S13°34'31"E	276.60	-2.00
L54	S32°47'55"W	226.03	-2.50
L55	S07°13'59"E	32.94	-1.50
L56	S07°13'59"E	330.00	1.50
L57	S07°13'59"E	389.19	-2.00
L58	N89°46'22"E	248.20	3.50
L59	N89°46'22"E	51.81	1.50
L60	N00°13'58"W	330.00	1.50
L61	N00°13'58"W	248.20	4.53
L62	N00°13'58"W	100.00	-1.50
L63	N72°33'34"W	231.00	3.00
L64	N22°58'34"E	332.90	-3.50
L65	N82°33'30"W	82.90	1.50
L66	N07°26'31"E	99.55	1.50
L67	N07°26'31"E	210.83	2.52
L68	N29°57'52"W	355.93	2.52
L69	- L66 NOT USED	-	-
L70	N07°26'31"E	426.96	-3.02
L71	N07°26'31"E	563.00	-1.50
L72	N82°33'30"E	203.00	2.77
L73	N07°26'31"E	134.87	-1.50
L74	S82°33'30"E	80.00	-1.50
L75	N07°26'31"E	204.50	1.50
L76	N07°26'31"E	178.07	4.08
L77	S89°46'22"W	94.77	1.50

**STREET & CURVE TABLE**

LINE	BEARING	LENGTH	SLOPE*
L84	S14°25'30"W	167.84	-1.50
L85	N82°33'30"E	150.39	3.56
L86	S82°33'30"E	182.00	4.09
L87	S07°26'31"W	25.00	-2.50
L88	-	-	-
L89	S07°26'31"W	84.32	1.50
L90	N00°45'58"E	196.15	-2.00
L91	N00°45'58"E	409.47	2.75
L92	N00°45'58"E	109.57	2.52
L93	N11°20'00"E	500.00	-3.50
L94	S89°08'55"E	99.69	1.50
L95	S89°08'55"E	344.72	1.01
L96	N00°51'08"E	123.20	-2.50
L97	S07°26'31"W	219.87	1.50
L98	N07°40'24"E	87.63	2.18
L99	S82°33'30"E	191.14	6.00
L100	S82°33'30"E	113.10	1.50
L101	S59°45'58"E	90.00	1.50
L102	S59°45'58"E	112.03	1.50
L103	S89°15'42"W	142.64	-4.25
L104	S15°46'17"W	665.14	-1.07
L105	S15°46'17"W	473.34	-1.50
L106	N24°13'43"E	178.07	4.08
L107	S24°13'43"E	178.07	4.08
L108	S89°46'22"W	94.77	1.50

**STREET & CURVE TABLE**

LINE	BEARING	LENGTH	RADIUS	SLOPE*
C1	309.61	690.71	-	-
C2	309.61	690.71	-	-
C3	654.32	775.00	-1.65	-
C4	34.61	775.00	-2.00	-
C5	446.72	775.00	-5.66	-
C6	208.77	200.00	2.52	-
C7	112.00	500.00	-3.50	-
C8	90.49	500.00	1.50	-
C9	67.58	52.00	-2.50	-
C10	78.62	200.00	2.52	-
C11	80.34	200.00	3.56	-
C12	46.61	400.00	2.75	-
C13	23.01	200.00	6.00	-
C14	31.35	200.00	6.00	-
C15	79.58	200.00	6.00	-
C16	102.98	200.00	-4.25	-
C17	82.43	63.00	-4.25	-
C18	55.85	200.00	1.50	-
C19	65.09	200.00	-2.50	-
C20	65.09	200.00	-2.50	-
C21	65.09	200.00	-2.50	-
C22	65.09	200.00	-2.50	-
C23	65.09	200.00	-2.50	-
C24	65.09	200.00	-2.50	-
C25	65.09	200.00	-2.50	-
C26	65.09	200.00	-2.50	-
C27	65.09	200.00	-2.50	-
C28	65.09	200.00	-2.50	-
C29	65.09	200.00	-2.50	-
C30	65.09	200.00	-2.50	-
C31	65.09	200.00	-2.50	-
C32	65.09	200.00	-2.50	-
C33	65.09	200.00	-2.50	-
C34	65.09	200.00	-2.50	-
C35	65.09	200.00	-2.50	-
C36	65.09	200.00	-2.50	-
C37	65.09	200.00	-2.50	-
C38	65.09	200.00	-2.50	-
C39	65.09	200.00	-2.50	-
C40	65.09	200.00	-2.50	-
C41	65.09	200.00	-2.50	-
C42	65.09	200.00	-2.50	-
C43	65.09	200.00	-2.50	-
C44	65.09	200.00	-2.50	-
C45	65.09	200.00	-2.50	-
C46	65.09	200.00	-2.50	-
C47	65.09	200.00	-2.50	-
C48	65.09	200.00	-2.50	-
C49	65.09	200.00	-2.50	-
C50	65.09	200.00	-2.50	-
C51	65.09	200.00	-2.50	-
C52	65.09	200.00	-2.50	-
C53	65.09	200.00	-2.50	-
C54	65.09	200.00	-2.50	-
C55	65.09	200.00	-2.50	-
C56	65.09	200.00	-2.50	-
C57	65.09	200.00	-2.50	-
C58	65.09	200.00	-2.50	-
C59	65.09	200.00	-2.50	-
C60	65.09	200.00	-2.50	-
C61	65.09	200.00	-2.50	-
C62	65.09	200.00	-2.50	-
C63	65.09	200.00	-2.50	-
C64	65.09	200.00	-2.50	-
C65	65.09	200.00	-2.50	-
C66	65.09	200.00	-2.50	-
C67	65.09	200.00	-2.50	-
C68	65.09	200.00	-2.50	-
C69	65.09	200.00	-2.50	-
C70	65.09	200.00	-2.50	-
C71	65.09	200.00	-2.50	-
C72	65.09	200.00	-2.50	-
C73	65.09	200.00	-2.50	-
C74	65.09	200.00	-2.50	-
C75	65.09	200.00	-2.50	-
C76	65.09	200.00	-2.50	-
C77	65.09	200.00	-2.50	-
C78	65.09	200.00	-2.50	-
C79	65.09	200.00	-2.50	-
C80	65.09	200.00	-2.50	-
C81	65.09	200.00	-2.50	-
C82	65.09	200.00	-2.50	-
C83	65.09	200.00	-2.50	-
C84	65.09	200.00	-2.50	-
C85	65.09	200.00	-2.50	-

**MONUMENT RIDGE EAST**  
 LOCATED IN THE NORTH ONE-HALF OF SECTION 2, T 11 S, R 67 W OF THE 6th P.M.  
 EL PASO COUNTY, COLORADO

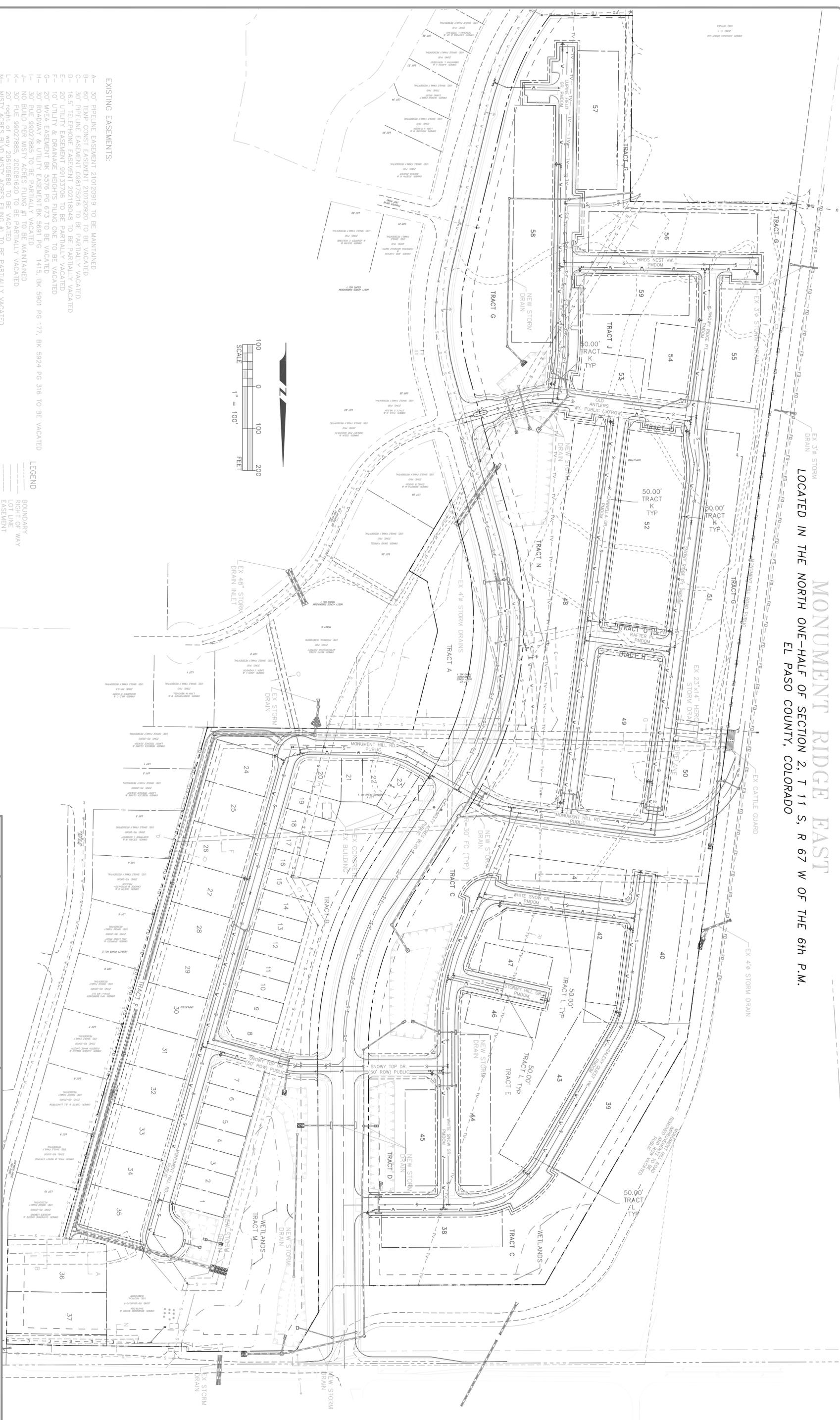

**EXISTING EASEMENTS:**

- A- 30' PIPELINE EASEMENT 210120919 TO BE MAINTAINED
- B- 60' TEMP CONST EASEMENT 210120920 TO BE VACATED
- C- 30' PIPELINE EASEMENT 09817216 TO BE PARTIALLY VACATED
- D- 16.5' TELEPHONE EASEMENT 202118048 TO BE PARTIALLY VACATED
- E- 20' UTILITY EASEMENT 99133706 TO BE PARTIALLY VACATED
- F- 10' UTILITY & DRAINAGE HEIGHTS FILING ONE TO BE VACATED
- G- 20' W/EA EASEMENT BK 5576 PG 673 TO BE VACATED
- H- 30' ROADWAY & UTILITY EASEMENT BK 5691 PG 1415, BK 5901 PG 177, BK 5924 PG 316 TO BE VACATED
- I- 30' PUE 99027885 TO BE PARTIALLY VACATED
- J- NO BUILD PER MISTY AGRES FILING #1 TO BE MAINTAINED
- K- 30' PUE 99027885, 200091620 TO BE PARTIALLY VACATED
- L- 20' right of way 206105680 TO BE VACATED
- M- MISTY AGRES BLVD MISTY AGRES FILING #1 TO BE PARTIALLY VACATED
- N- 20' W/EA EASEMENT 200090983 TO BE MAINTAINED
- O- 16' WOODMORE UTILITY EASEMENT TO BE MAINTAINED
- P- 16' WOODMORE UTILITY EASEMENT TO BE MAINTAINED
- Q- 50' WOODMORE TEMP CONST EASEMENT TO BE VACATED
- R- CABLE LINE APPROXIMATE LOCATION TO BE VACATED

**LEGEND**

- BOUNDARY
- RIGHT OF WAY
- ROADWAY
- WATER
- SEWER
- FORCE MAIN
- TELEPHONE
- FIBER
- EX ROADS
- STORM DRAIN
- PROPOSED FIRE HYDRANT
- PDMDM Public Metropolitan District Owned and Maintained



**BEAR CREEK SURVEYING INC.**  
 BRENT SMITH  
 95 South Bear Creek Road, Bayfield CO 81222  
 P.O. Box 2005, Bayfield CO 81222  
 PH(970)884-5089

CLIENT: **MONUMENT RIDGE EAST, LLC**  
 MUNICIPALITY: **EL PASO**  
 COUNTY: **EL PASO**

OWNER OF RECORD: **MONUMENT RIDGE EAST LLC**  
 ADDRESS: **5055 LIST DRIVE**  
 COLORADO SPRINGS, CO 80919

DRAFTED BY: **DHJ**  
 CHECKED BY: **BJS**  
 PROJECT #: **21-014**  
 SHEET 2 OF 4

**PRELIMINARY PLAN**

SUBMISSION DATE: **4/12/24**  
 REVISION DATES: **8/12/24**  
 REVISION DATES: **11/08/24**

