

DRAINAGE CONFORMANCE LETTER
FOR
WALDEN SANITATION DISTRICT WWTP
3155 WALKER ROAD, EL PASO COUNTY, COLORADO
PART OF WALDEN PRESERVE 2 – FILING NO. 5

NOVEMBER 2025
REVISED MARCH 2026

PREPARED FOR:
Walden Sanitation District
3155 Walker Road
Colorado Springs, El Paso County, CO 80908

PREPARED BY:



K A T Z
—LDE—

Katz LDE LLC
3045 Richard Allen Court
Denver, CO 80205
(847) 826-0522
dkatz@katzlde.com
www.katzlde.com

PCD FILE PPR2538

Katz LDE Project No. 250041

**WALDEN SANITATION DISTRICT WWTP
DRAINAGE CONFORMANCE LETTER
PAGE 1 OF 7**

ENGINEER'S STATEMENT:

The attached drainage conformance letter was prepared under my direction and supervision and is correct to the best of my knowledge and belief. Said drainage conformance letter has been prepared according to the criteria established by the city/county for drainage reports and said report is in conformity with the master plan of the drainage basin. I accept responsibility for any liability caused by any negligent acts, errors or omissions on my part in preparing this report.



Daniel Katz, P.E.
State of Colorado No. 52465
For and on behalf of Katz LDE LLC

DEVELOPER'S STATEMENT:

I, Bill Douston the developer have read and will comply with all of the requirements specified in this drainage report and plan.

[Signature]

Walden Sanitation District
By: Bill Douston
Title: Vice President
Address: 1310 Embassy Ct

2-16-26

Date

EL PASO COUNTY STATEMENT:

Filed in accordance with the requirements of the Drainage Criteria Manual, Volumes 1 and 2, El Paso County Engineering Criteria Manual and Land Development Code as amended.

County Engineer / ECM Administrator

Date

Conditions:

**WALDEN SANITATION DISTRICT WWTP
DRAINAGE CONFORMANCE LETTER
PAGE 2 OF 7**

SCOPE

The purpose of this Drainage Conformance Letter is to present the drainage plan for the Walden Sanitation District Wastewater Treatment Plant (WWTP) project. The following includes analysis information for the proposed project in conformance with the El Paso County Drainage Criteria Manual.

I. GENERAL PROPERTY DESCRIPTION

The proposed Walden Sanitation District WWTP project is located at 3155 Walker Road in unincorporated El Paso County, Colorado. The site resides within Walden Preserve 2 – Filing No. 5 and is bordered to the north by Walker Road, to the east by existing residential lots, to the south by future residential lots, and to the west by a future school.

The overall property area is 25.00 acres and consists of both parcels 6115000005 and 6115000001, however the project area and area of disturbance associated with the proposed improvements for the WWTP is significantly smaller, limited to less than one acre. This project area spans the limits of both parcels.

Southwest of the WWTP project limits, an approximately 3-acre area remains disturbed from a previous material stockpile operation. This area lies within the overall property boundary but outside the limits of the proposed improvements and was completed under a separate scope of work.

Excluding the disturbed stockpile area described above, the overall 25-acre property is largely undisturbed native grassland with limited paved and gravel access roads, and a small existing wastewater treatment facility. Based on visual observation of recent Google Earth aerial imagery, the grassland areas of the site are estimated to support greater than 80% native vegetative cover. Access roads, the existing wastewater treatment facility, the disturbed stockpile area, and the wet-bottom pond were excluded from this determination, as these areas are not capable of supporting continuous vegetative growth. Stabilization of the disturbed stockpile area is discussed later in this narrative.

Soil types in the project area as identified by the Natural Resources Conservation Service (NRCS) are as follows:

Hydrologic Soil Group			
Map unit symbol	Map unit name	Rating	Percent of AOI
71	Pring coarse sandy loam, 3 to 8 percent	B	100%

The site is located near a floodplain for the East Tributary of West Cherry Creek as shown on the FEMA FIRM Map No. 08041C0285G effective December 7, 2018. The majority of the project site lies within Zone X – Area of Minimal Flood Hazard, however there will be a minor amount of cut and impact to the Zone A floodplain at the downstream outfall of the effluent line from the WWTP.

II. GENERAL EXISTING DRAINAGE CHARACTERISTICS

The existing WWTP site is currently developed with several small wastewater treatment structures, a paved asphalt access road, and gravel service paths. The proposed WWTP project area slopes generally to the east, with all runoff sheet flowing toward an on-site wet-bottom pond that serves as the local outfall. There are no defined channels or stormwater infrastructure within the immediate project area, however, apart from the areas directly tributary to the existing wet-bottom ponds, the overall parcels ultimately drain to the East Tributary of West Cherry Creek along the eastern edge of the property, and then to an existing 41" x 26" HECMP culvert flowing north underneath Walker Road. Offsite drainage patterns remain unaffected. Walker Road borders the site to the north, with residential development located to the south and east.

This site lies within Sub-Basin C13 of the "Final Drainage Report for Walden Preserve 2 – Filing No. 5," prepared by JPS Engineering and last revised July 7, 2022. Although technically part of the C13 sub-basin, the area impacted by this project is minor and continues to drain in the same manner as under existing conditions, via sheet flow to the wet-bottom pond. As such, the prior report offers limited detail specific to this location, and no modifications to the approved basin-wide drainage strategy are warranted. See enclosures for the drainage map excerpt from this report.

III. GENERAL PROPOSED DRAINAGE CHARACTERISTICS

The proposed scope of work includes installation of new underground sanitary sewer utilities, expansion of the WWTP infrastructure on new concrete pads, and limited gravel access and parking areas. The proposed grading generally maintains existing drainage patterns but introduces a new concrete pan along the west side of the improvements. This pan will capture minor nuisance flows and route them north around the proposed infrastructure, before discharging eastward into the existing wet-bottom pond. This flow path is consistent with historic conditions and ensures no runoff is conveyed across the WWTP infrastructure. No drainage will be directed offsite or to adjacent properties.

The proposed sanitary sewer effluent outfall will discharge to the existing roadside ditch along Walker Road at Design Point EF shown on the proposed Drainage Plan, south of the right-of-way, and is independent of the site storm drainage system. The outfall will consist of an 8-inch PVC pipe conveying an intermittent discharge of approximately 174 gpm (0.39 cfs). Energy dissipation and erosion protection will be provided by a riprap apron at the outlet. Alternative discharge locations were evaluated; however, the proposed configuration was determined to be the most feasible and constructible option.

Alternatives Considered:

1. Selected Alternative A - Gravity Discharge to On-Site Roadway Drainage (West Cherry Creek Basin)
 - Utilizes existing drainage infrastructure immediately adjacent to the WWTP site
 - Allows gravity flow from the treatment plant, eliminating pumping requirements and associated O&M costs
 - Shortest conveyance distance, minimizing infrastructure and right-of-way needs
 - Discharges to West Cherry Creek Basin via existing drainage pathway

WALDEN SANITATION DISTRICT WWTP

DRAINAGE CONFORMANCE LETTER

PAGE 4 OF 7

2. Alternative B - Pumped Discharge to Western Drainage Point (West Cherry Creek Basin)
 - Requires approximately 3,950 linear feet of force main to reach alternative drainage point
 - Necessitates lift station with redundant pumps
 - Discharges to same receiving basin (West Cherry Creek Basin) as selected alternative
 - Significantly higher capital cost
 - Does not provide measurable water quality or regulatory benefit vs. selected alternative since both discharge to the same basin
 - Rejected due to cost differential without corresponding environmental or regulatory benefit

As previously mentioned, southwest of the WWTP project limits, an approximately 3-acre area remains disturbed from a previous material stockpile operation. This area lies within the overall property boundary but outside the limits of the proposed improvements and was completed under a separate scope of work. While not part of the current design, as a condition of approval for this project it will be restored prior to construction of the WWTP. Restoration will include regrading to pre-stockpile conditions and permanent stabilization to achieve at least 70% vegetative cover. A letter from the owner has been included in the enclosures to document this.

IV. WATER QUALITY

Revise section as necessary after addressing comments in GEC plan

The El Paso County Drainage Criteria Manual requires that water quality capture volume (WQCV) treatment be provided for applicable development areas of one (1) acre or larger. The direct disturbance associated with the proposed WWTP improvements is approximately 0.39 acres, which is below this threshold and does not, by itself, trigger a requirement for on-site WQCV treatment.

As previously mentioned, an approximately 3-acre area southwest of the WWTP limits was previously disturbed for stockpiling activities, which, when combined with the WWTP disturbance, would exceed the 1-acre disturbance threshold if considered as a single development area. However, this stockpile area is being regraded and permanently stabilized to restore its pre-development condition as vegetated open space, prior to the WWTP project construction, and no permanent impervious surfaces are proposed within this area. Once restored, the stockpile area will function as pervious landscape rather than developed impervious area, and therefore should not be treated as a WQCV-controlled development area under the El Paso County criteria.

Given the limited extent of permanent impervious area increase associated with the WWTP improvements (approximately 5,734 square feet) and the planned restoration of the former stockpile area to stabilized native vegetation, no permanent water quality BMPs or WQCV facilities are proposed as part of this project.

V. HYDROLOGIC CALCULATION RESULTS

The project introduces approximately 5,734 square feet of new impervious surface, including paved and gravel areas. Although the total disturbed area remains under one acre and does not trigger a full stormwater quality evaluation, hydrologic calculations have been performed to document changes in runoff characteristics resulting from the proposed development.

The overall 25.00-acre property was analyzed and divided into four sub-basins based on localized drainage divides. A portion of the site along the western boundary was not analyzed, as this area drains to the existing Extended Detention Basin associated with the adjacent Mountain

**WALDEN SANITATION DISTRICT WWTP
DRAINAGE CONFORMANCE LETTER
PAGE 5 OF 7**

Site development plan shows drain pipes taking flows from these basins north. please revise.

View Academy Development (PCD Project No. PPR-19-009), which is separate from this project. The four on-site sub-basins are described as follows:

EX1 & D1 – Sub-basins EX1 and D1 represent the same drainage area, with EX1 reflecting existing conditions and D1 representing proposed conditions. Under existing conditions, the basin includes portions of asphalt and gravel roadways, the existing wastewater treatment facility, undeveloped open space, and the larger southern wet-bottom pond. Runoff from this basin generally sheet flows east into the existing pond at Design Point EX1.

In the proposed condition, new pavement, gravel, and structures associated with the Wastewater Treatment Plant (WWTP) addition are introduced. The proposed grading generally maintains existing drainage patterns but adds a new concrete pan along the west side of the improvements. This pan will capture minor nuisance flows, routing them north around the proposed infrastructure before discharging eastward into the existing wet-bottom pond at Design Point D1. This flow path remains consistent with historic conditions and ensures that no runoff is conveyed across the WWTP infrastructure.

The calculated peak flow results indicate that the 5-year peak storm runoff increases by 0.42 cfs and the 100-year peak flow increases by 0.63 cfs. These nominal increases are directed into the existing wet-bottom pond, which will continue to serve as the site's outfall. The new concrete pan helps maintain drainage segregation and prevents surface flows from crossing critical infrastructure. No additional stormwater conveyance systems are required or proposed.

EX2 – This sub-basin consists primarily of undeveloped open space and a segment of the existing gravel access road. Runoff from this basin generally flows northeast offsite into the East Tributary of West Cherry Creek at Design Point EX2. The proposed WWTP project does not alter this basin; ground cover and drainage patterns remain unchanged.

EX3 – This sub-basin includes disturbed open space currently being restored from a former stockpile area to its vegetated historic condition, as well as a portion of an existing paved access road and the northern, smaller wet-bottom pond. Runoff from this basin flows northeast into the existing pond at Design Point EX3. The proposed WWTP improvements do not affect this basin, and its ground cover and drainage patterns will be restored to historic conditions.

EX4 – This sub-basin primarily consists of undeveloped open space, a segment of the East Tributary of West Cherry Creek, and a portion of the paved gravel access road. Runoff flows north to an existing 41" x 26" HECMP culvert that conveys the tributary beneath Walker Road at Design Point EX4. This location corresponds to Design Point 4 in the Walden Preserve 2 – Filing No. 5 Final Drainage Report. An excerpt from that report is included in the enclosures, showing historic and detained flow rates at this point.

Per the Walden Preserve 2 – Filing No. 5 Final Drainage Report, the 100-year peak flows at Design Point 4 are 620.0 cfs in the historic condition and 601.4 cfs in the proposed detained condition. Given ongoing upstream development, it is reasonable to assume that the current actual peak flow falls between these two values. The proposed WWTP project adds a new effluent discharge line within this basin that contributes 0.39 cfs of peak flow to this design point—a 0.06% increase relative to the historic 100-year rate. When combined with the detained 100-year peak flow, the total remains below the historic condition. This minor flow increase is not expected to produce any adverse effects on downstream drainage conditions at Design Point EX4 (Design Point 4).

**WALDEN SANITATION DISTRICT WWTP
DRAINAGE CONFORMANCE LETTER
PAGE 6 OF 7**

The peak flow analysis, including tabulations of tributary areas, runoff coefficients, times of concentration, rainfall intensities, and peak discharge rates (Q) for both existing and proposed conditions, is provided in the enclosures.

Peak Flow Rate and Pipe Sizing for the WWTP Effluent Line:

The effluent discharge system operates as a batch discharge from the Phosphorus Polishing Break Tank (1,810-gallon working volume). The discharge pump operates at 174 gpm (0.388 cfs), resulting in a velocity of 1.1 ft/s in the 8-inch discharge pipe.

Pipe Sizing Verification:

- Flow Rate: $Q = 0.388$ cfs
- Pipe Diameter: 8 inches (0.667 ft)
- Pipe Area: $A = \pi(D/2)^2 = 0.349$ ft²
- Velocity: $V = Q/A = 0.388$ cfs / 0.349 ft² = 1.1 ft/s

The 8-inch pipe was sized to provide adequate capacity while maintaining velocity below 2.0 ft/s to minimize turbulence and potential for erosion at the outfall point.

Each batch discharge cycle lasts approximately 10 minutes (1,810 gallons ÷ 174 gpm).

Under design conditions:

- **Design Flow (150,000 gpd):** Approximately 83 batches per day (average 17-minute intervals)
- **Peak Daily Flow (225,000 gpd):** Approximately 124 batches per day (average 12-minute intervals)

The discharge is intermittent, not continuous. Each discharge event is brief (10 minutes), with significant recovery time between events.

The ROW ditch was selected as the discharge point based on the following considerations:

1. **Proximity and Feasibility:** The ROW ditch is the nearest suitable outfall point, minimizing pipeline length and construction disturbance.
2. **Gravity Discharge:** The routing allows for gravity discharge to an established drainage conveyance, eliminating the need for additional pumping infrastructure.
3. **Existing Infrastructure:** The ROW ditch is an established drainage feature designed to convey stormwater. The treated effluent discharge represents a minor addition to the ditch's design capacity and is significantly cleaner than typical stormwater runoff.

Outfall Protection for the WWTP Effluent Line:

Outlet protection for the effluent discharge was evaluated using the Mile High Flood District (MHFD) Culvert v4.01 spreadsheet by modeling the terminal 8-inch effluent pipe as a culvert barrel to determine outlet velocity and required energy dissipation. For the design discharge of 0.388 cfs, the calculated minimum protection consists of a Type VL riprap apron with a required length of approximately 2 feet and width of 1 foot.

WALDEN SANITATION DISTRICT WWTP

DRAINAGE CONFORMANCE LETTER

PAGE 7 OF 7

Due to the frequent and repetitive nature of the intermittent effluent discharges, the riprap apron has been conservatively enlarged to approximately 5.5 feet wide by 12.5 feet long to provide additional scour protection and improve long-term stability at the outfall.

In accordance with the El Paso County Drainage Criteria Manual, Volume 2, Table 10-4, the lowest permissible mean channel velocity for vegetated earth channels is 2.5 ft/s. Hydraulic calculations included in the appendix indicate the receiving ditch velocity is approximately 1.4 ft/s with a maximum shear stress of 0.23 lb/sf. Both the ditch velocity and the pipe outlet velocity (1.1 ft/s) are well below the permissible limits; therefore, channel lining is not required. Type VL riprap outlet protection is provided solely to prevent localized scour at the pipe discharge point.

VI. CONCLUSION

The proposed improvements to the Walden Sanitation District Wastewater Treatment Plant represent a minor expansion within an already developed and previously approved drainage basin. The immediate project site will maintain its existing drainage patterns, with all runoff continuing to flow eastward into the existing on-site wet-bottom pond. The net increase in impervious area is minimal and will not result in any measurable offsite impacts or require new conveyance or detention facilities.

In addition, the proposed sanitary effluent outfall will discharge intermittently to the existing roadside ditch along Walker Road via an 8-inch PVC gravity line. The discharge is independent of the site storm drainage system and will be protected with a riprap apron to prevent erosion. The intermittent, treated effluent flow represents a minor addition to the capacity of the existing ditch and will not adversely affect downstream drainage patterns or infrastructure.

This drainage letter confirms compliance with the El Paso County Drainage Criteria Manual. Because the project disturbs less than one acre, CDPS stormwater permitting and MS4 requirements are not triggered, and a State Construction Stormwater Discharge Permit is not required. The existing wastewater treatment plant maintains a valid wastewater discharge permit. No additional drainage improvements or mitigation measures are warranted. No adverse drainage impacts are anticipated, and no variances from County drainage standards are requested.

ENCLOSURES

- Referenced Information
- Hydrologic & Hydraulic Calculations
- Drainage Plans

Please include the Four-Step
Process (ECM Appendix I.7.2.A.)

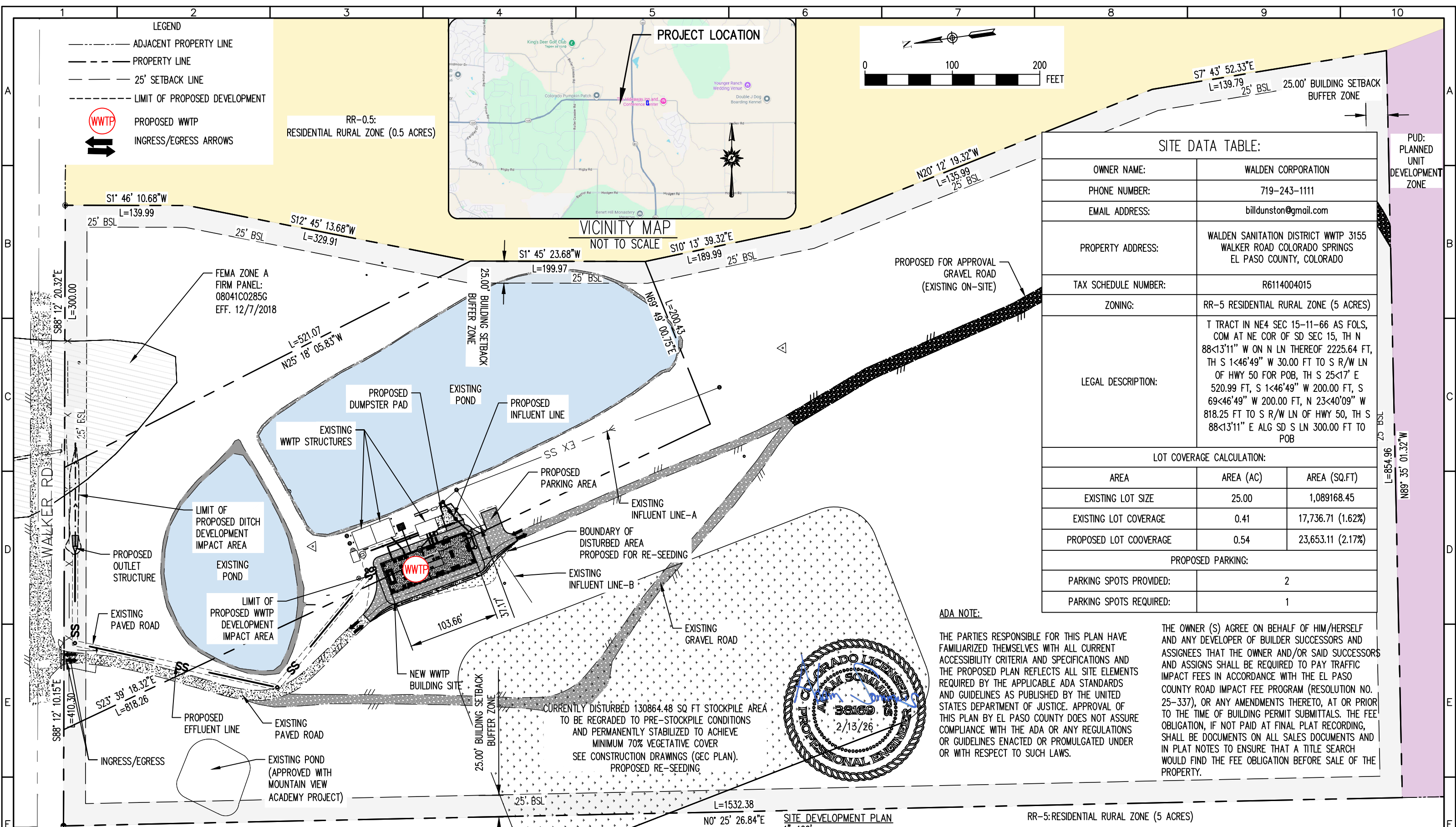

SITE DATA TABLE:

OWNER NAME:	WALDEN CORPORATION	
PHONE NUMBER:	719-243-1111	
EMAIL ADDRESS:	billdunston@gmail.com	
PROPERTY ADDRESS:	WALDEN SANITATION DISTRICT WWTP 3155 WALKER ROAD COLORADO SPRINGS EL PASO COUNTY, COLORADO	
TAX SCHEDULE NUMBER:	R6114004015	
ZONING:	RR-5 RESIDENTIAL RURAL ZONE (5 ACRES)	
LEGAL DESCRIPTION:	T TRACT IN NE4 SEC 15-11-66 AS FOLS, COM AT NE COR OF SD SEC 15, TH N 88<13'11" W ON N LN THEREOF 2225.64 FT, TH S 1<46'49" W 30.00 FT TO S R/W LN OF HWY 50 FOR POB, TH S 25<17' E 520.99 FT, S 1<46'49" W 200.00 FT, S 69<46'49" W 200.00 FT, N 23<40'09" W 818.25 FT TO S R/W LN OF HWY 50, TH S 88<13'11" E ALG SD S LN 300.00 FT TO POB	
LOT COVERAGE CALCULATION:		
AREA	AREA (AC)	AREA (SQ.FT)
EXISTING LOT SIZE	25.00	1,089,168.45
EXISTING LOT COVERAGE	0.41	17,736.71 (1.62%)
PROPOSED LOT COVERAGE	0.54	23,653.11 (2.17%)
PROPOSED PARKING:		
PARKING SPOTS PROVIDED:	2	
PARKING SPOTS REQUIRED:	1	



REV. No:	DATE:	BY:	REVISION DESCRIPTION:

DESIGNED BY: MG
 CHECKED BY: AS
 FILE PRINTED ON: 2/13/2026 4:48:07 PM
 COPYRIGHT: AQUAWORKS DBO, INC.

0 1 IF THIS BAR DOES NOT READ 1" DRAWING IS NOT LABELED TO SCALE

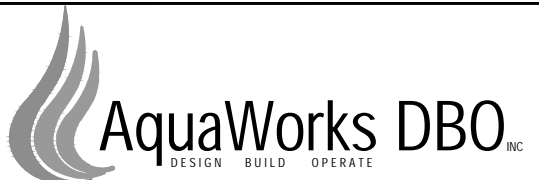

PROJECT: WALDEN CORPORATION WWTP 3155 WALKER ROAD COLORADO SPRINGS EL PASO COUNTY, COLORADO	SHEET TITLE: SITE DEVELOPMENT PLAN	
ENGINEER: AQUAWORKS DBO, INC. 3252 WILLIAMS STREET DENVER, COLORADO 80205 (303) 477-5915	PROJECT NUMBER: PCD FILE PPR2538	SCALE: 1"=100'
		SHEET: C1.1

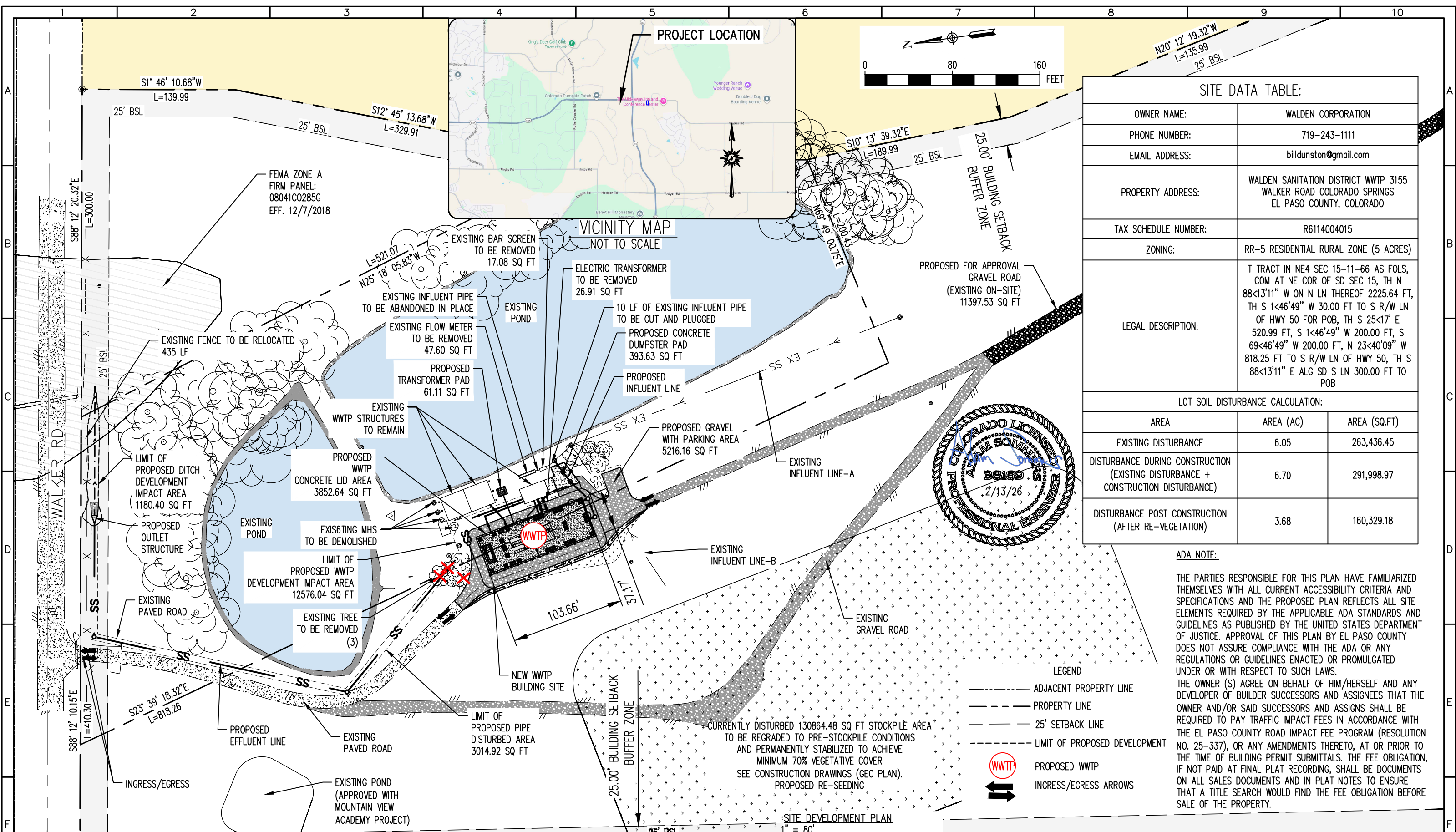

SITE DATA TABLE:		
OWNER NAME:	WALDEN CORPORATION	
PHONE NUMBER:	719-243-1111	
EMAIL ADDRESS:	billdunston@gmail.com	
PROPERTY ADDRESS:	WALDEN SANITATION DISTRICT WWTP 3155 WALKER ROAD COLORADO SPRINGS EL PASO COUNTY, COLORADO	
TAX SCHEDULE NUMBER:	R6114004015	
ZONING:	RR-5 RESIDENTIAL RURAL ZONE (5 ACRES)	
LEGAL DESCRIPTION:	T TRACT IN NE4 SEC 15-11-66 AS FOLS, COM AT NE COR OF SD SEC 15, TH N 88<13'11" W ON N LN THEREOF 2225.64 FT, TH S 1<46'49" W 30.00 FT TO S R/W LN OF HWY 50 FOR POB, TH S 25<17' E 520.99 FT, S 1<46'49" W 200.00 FT, S 69<46'49" W 200.00 FT, N 23<40'09" W 818.25 FT TO S R/W LN OF HWY 50, TH S 88<13'11" E ALG SD S LN 300.00 FT TO POB	
LOT SOIL DISTURBANCE CALCULATION:		
AREA	AREA (AC)	AREA (SQ.FT)
EXISTING DISTURBANCE	6.05	263,436.45
DISTURBANCE DURING CONSTRUCTION (EXISTING DISTURBANCE + CONSTRUCTION DISTURBANCE)	6.70	291,998.97
DISTURBANCE POST CONSTRUCTION (AFTER RE-VEGETATION)	3.68	160,329.18

ADA NOTE:

THE PARTIES RESPONSIBLE FOR THIS PLAN HAVE FAMILIARIZED THEMSELVES WITH ALL CURRENT ACCESSIBILITY CRITERIA AND SPECIFICATIONS AND THE PROPOSED PLAN REFLECTS ALL SITE ELEMENTS REQUIRED BY THE APPLICABLE ADA STANDARDS AND GUIDELINES AS PUBLISHED BY THE UNITED STATES DEPARTMENT OF JUSTICE. APPROVAL OF THIS PLAN BY EL PASO COUNTY DOES NOT ASSURE COMPLIANCE WITH THE ADA OR ANY REGULATIONS OR GUIDELINES ENACTED OR PROMULGATED UNDER OR WITH RESPECT TO SUCH LAWS.

THE OWNER (S) AGREE ON BEHALF OF HIM/HERSELF AND ANY DEVELOPER OF BUILDER SUCCESSORS AND ASSIGNEES THAT THE OWNER AND/OR SAID SUCCESSORS AND ASSIGNEES SHALL BE REQUIRED TO PAY TRAFFIC IMPACT FEES IN ACCORDANCE WITH THE EL PASO COUNTY ROAD IMPACT FEE PROGRAM (RESOLUTION NO. 25-337), OR ANY AMENDMENTS THERETO, AT OR PRIOR TO THE TIME OF BUILDING PERMIT SUBMITTALS. THE FEE OBLIGATION, IF NOT PAID AT FINAL PLAT RECORDING, SHALL BE DOCUMENTS ON ALL SALES DOCUMENTS AND IN PLAT NOTES TO ENSURE THAT A TITLE SEARCH WOULD FIND THE FEE OBLIGATION BEFORE SALE OF THE PROPERTY.

REV. No:	DATE:	BY:	REVISION DESCRIPTION:

DESIGNED BY: MG
CHECKED BY: AS
FILE PRINTED ON: 2/13/2026 4:48:07 PM
COPYRIGHT: AQUAWORKS DBO, INC.
0 1 IF THIS BAR DOES NOT READ 1" DRAWING IS NOT LABELED TO SCALE

AquaWorks DBO
DESIGN BUILD OPERATE

PROJECT: WALDEN CORPORATION WWTP
3155 WALKER ROAD COLORADO SPRINGS
EL PASO COUNTY, COLORADO

ENGINEER: AQUAWORKS DBO, INC.
3252 WILLIAMS STREET
DENVER, COLORADO 80205
(303) 477-5915

SHEET TITLE:
SITE DEVELOPMENT PLAN

PROJECT NUMBER: PCD FILE PPR2538	SCALE: 1" = 80'	SHEET: C1.2
-------------------------------------	--------------------	----------------

National Flood Hazard Layer FIRMette



104°46'14"W 39°6'9"N

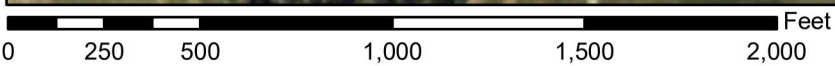

1:6,000

104°45'36"W 39°5'42"N

Basemap Imagery Source: USGS National Map 2023

Legend

SEE FIS REPORT FOR DETAILED LEGEND AND INDEX MAP FOR FIRM PANEL LAYOUT

SPECIAL FLOOD HAZARD AREAS		Without Base Flood Elevation (BFE) <i>Zone A, V, A99</i>
		With BFE or Depth <i>Zone AE, AO, AH, VE, AR</i>
		Regulatory Floodway
OTHER AREAS OF FLOOD HAZARD		0.2% Annual Chance Flood Hazard, Areas of 1% annual chance flood with average depth less than one foot or with drainage areas of less than one square mile <i>Zone X</i>
		Future Conditions 1% Annual Chance Flood Hazard <i>Zone X</i>
		Area with Reduced Flood Risk due to Levee. See Notes. <i>Zone X</i>
		Area with Flood Risk due to Levee <i>Zone D</i>
OTHER AREAS		NO SCREEN Area of Minimal Flood Hazard <i>Zone X</i>
		Effective LOMRs
GENERAL STRUCTURES		Area of Undetermined Flood Hazard <i>Zone D</i>
		Channel, Culvert, or Storm Sewer
		Levee, Dike, or Floodwall
OTHER FEATURES		20.2 Cross Sections with 1% Annual Chance Water Surface Elevation 17.5
		Coastal Transect
		Base Flood Elevation Line (BFE)
		Limit of Study
		Jurisdiction Boundary
MAP PANELS		Coastal Transect Baseline
		Profile Baseline
		Hydrographic Feature
		Digital Data Available
		No Digital Data Available
		Unmapped
		The pin displayed on the map is an approximate point selected by the user and does not represent an authoritative property location.



This map complies with FEMA's standards for the use of digital flood maps if it is not void as described below. The basemap shown complies with FEMA's basemap accuracy standards

The flood hazard information is derived directly from the authoritative NFHL web services provided by FEMA. This map was exported on **11/10/2025 at 5:56 PM** and does not reflect changes or amendments subsequent to this date and time. The NFHL and effective information may change or become superseded by new data over time.

This map image is void if the one or more of the following map elements do not appear: basemap imagery, flood zone labels, legend, scale bar, map creation date, community identifiers, FIRM panel number, and FIRM effective date. Map images for unmapped and unmodernized areas cannot be used for regulatory purposes.

Hydrologic Soil Group—El Paso County Area, Colorado
(Walden Sanitation District WWTP)

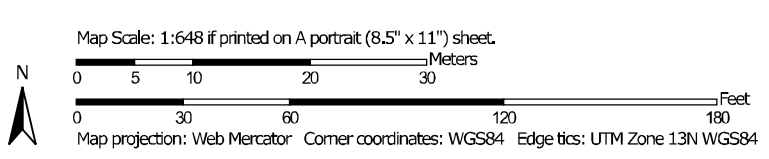
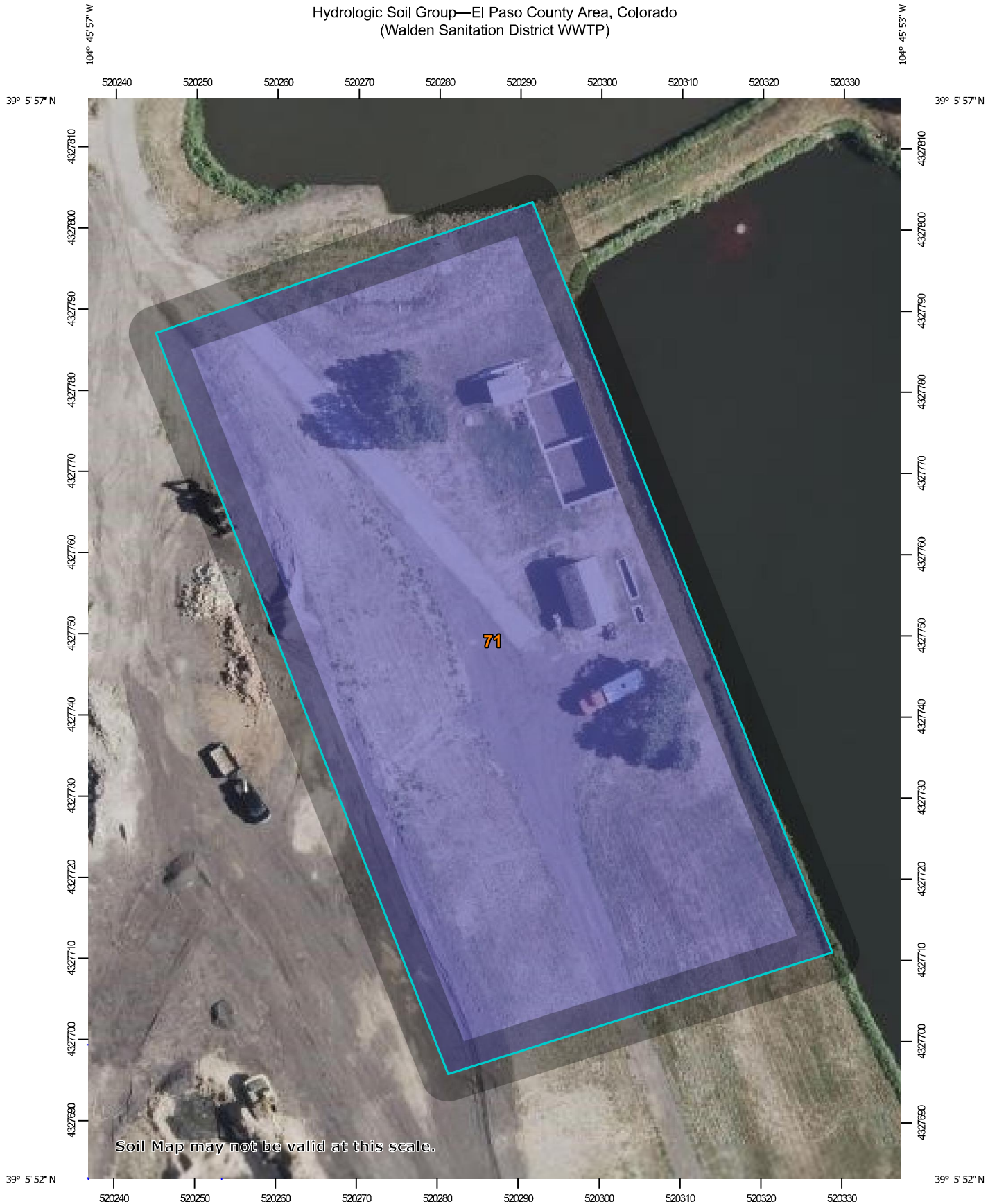









MAP LEGEND









Area of Interest (AOI)
 Area of Interest (AOI)

Soils





Soil Rating Polygons

-  A
-  A/D
-  B
-  B/D
-  C
-  C/D
-  D
-  Not rated or not available

Soil Rating Lines

-  A
-  A/D
-  B
-  B/D
-  C
-  C/D
-  D
-  Not rated or not available

Soil Rating Points

-  A
-  A/D
-  B
-  B/D

MAP INFORMATION

The soil surveys that comprise your AOI were mapped at 1:24,000.

Warning: Soil Map may not be valid at this scale.

Enlargement of maps beyond the scale of mapping can cause misunderstanding of the detail of mapping and accuracy of soil line placement. The maps do not show the small areas of contrasting soils that could have been shown at a more detailed scale.

Please rely on the bar scale on each map sheet for map measurements.

Source of Map: Natural Resources Conservation Service
 Web Soil Survey URL:
 Coordinate System: Web Mercator (EPSG:3857)

Maps from the Web Soil Survey are based on the Web Mercator projection, which preserves direction and shape but distorts distance and area. A projection that preserves area, such as the Albers equal-area conic projection, should be used if more accurate calculations of distance or area are required.

This product is generated from the USDA-NRCS certified data as of the version date(s) listed below.

Soil Survey Area: El Paso County Area, Colorado
 Survey Area Data: Version 23, Aug 29, 2025

Soil map units are labeled (as space allows) for map scales 1:50,000 or larger.

Date(s) aerial images were photographed: Jul 23, 2024—Aug 4, 2024

The orthophoto or other base map on which the soil lines were compiled and digitized probably differs from the background imagery displayed on these maps. As a result, some minor shifting of map unit boundaries may be evident.

Hydrologic Soil Group

Map unit symbol	Map unit name	Rating	Acres in AOI	Percent of AOI
71	Pring coarse sandy loam, 3 to 8 percent slopes	B	1.2	100.0%
Totals for Area of Interest			1.2	100.0%

Description

Hydrologic soil groups are based on estimates of runoff potential. Soils are assigned to one of four groups according to the rate of water infiltration when the soils are not protected by vegetation, are thoroughly wet, and receive precipitation from long-duration storms.

The soils in the United States are assigned to four groups (A, B, C, and D) and three dual classes (A/D, B/D, and C/D). The groups are defined as follows:

Group A. Soils having a high infiltration rate (low runoff potential) when thoroughly wet. These consist mainly of deep, well drained to excessively drained sands or gravelly sands. These soils have a high rate of water transmission.

Group B. Soils having a moderate infiltration rate when thoroughly wet. These consist chiefly of moderately deep or deep, moderately well drained or well drained soils that have moderately fine texture to moderately coarse texture. These soils have a moderate rate of water transmission.

Group C. Soils having a slow infiltration rate when thoroughly wet. These consist chiefly of soils having a layer that impedes the downward movement of water or soils of moderately fine texture or fine texture. These soils have a slow rate of water transmission.

Group D. Soils having a very slow infiltration rate (high runoff potential) when thoroughly wet. These consist chiefly of clays that have a high shrink-swell potential, soils that have a high water table, soils that have a claypan or clay layer at or near the surface, and soils that are shallow over nearly impervious material. These soils have a very slow rate of water transmission.

If a soil is assigned to a dual hydrologic group (A/D, B/D, or C/D), the first letter is for drained areas and the second is for undrained areas. Only the soils that in their natural condition are in group D are assigned to dual classes.

Rating Options

Aggregation Method: Dominant Condition

Component Percent Cutoff: None Specified

Tie-break Rule: Higher



NOAA Atlas 14, Volume 8, Version 2
Location name: Colorado Springs, Colorado, USA*
Latitude: 39.0986°, Longitude: -104.7653°
Elevation: m/ft**
 * source: ESRI Maps
 ** source: USGS



POINT PRECIPITATION FREQUENCY ESTIMATES

Sanja Perica, Deborah Martin, Sandra Pavlovic, Ishani Roy, Michael St. Laurent, Carl Trypaluk, Dale Unruh, Michael Yekta, Geoffery Bonnin

NOAA, National Weather Service, Silver Spring, Maryland

[PF_tabular](#) | [PF_graphical](#) | [Maps & aerials](#)

PF tabular

PDS-based point precipitation frequency estimates with 90% confidence intervals (in inches)¹										
Duration	Average recurrence interval (years)									
	1	2	5	10	25	50	100	200	500	1000
5-min	0.235 (0.193-0.286)	0.287 (0.236-0.351)	0.378 (0.310-0.463)	0.458 (0.374-0.563)	0.575 (0.454-0.734)	0.670 (0.515-0.864)	0.770 (0.571-1.01)	0.875 (0.621-1.18)	1.02 (0.696-1.41)	1.14 (0.752-1.58)
10-min	0.343 (0.283-0.419)	0.421 (0.346-0.514)	0.554 (0.454-0.678)	0.671 (0.547-0.824)	0.842 (0.665-1.08)	0.981 (0.755-1.26)	1.13 (0.836-1.48)	1.28 (0.909-1.73)	1.50 (1.02-2.06)	1.67 (1.10-2.32)
15-min	0.419 (0.345-0.511)	0.513 (0.422-0.626)	0.676 (0.554-0.827)	0.819 (0.667-1.00)	1.03 (0.811-1.31)	1.20 (0.920-1.54)	1.37 (1.02-1.81)	1.56 (1.11-2.11)	1.82 (1.24-2.52)	2.03 (1.34-2.83)
30-min	0.606 (0.499-0.739)	0.741 (0.610-0.904)	0.974 (0.799-1.19)	1.18 (0.960-1.45)	1.48 (1.17-1.89)	1.72 (1.32-2.22)	1.98 (1.47-2.60)	2.25 (1.60-3.03)	2.62 (1.79-3.62)	2.92 (1.93-4.07)
60-min	0.771 (0.636-0.941)	0.931 (0.766-1.14)	1.22 (0.997-1.49)	1.47 (1.20-1.81)	1.86 (1.48-2.39)	2.18 (1.68-2.83)	2.53 (1.88-3.34)	2.90 (2.06-3.92)	3.43 (2.34-4.75)	3.86 (2.55-5.37)
2-hr	0.937 (0.776-1.13)	1.12 (0.928-1.36)	1.46 (1.20-1.77)	1.77 (1.45-2.16)	2.24 (1.80-2.87)	2.65 (2.06-3.41)	3.08 (2.31-4.06)	3.56 (2.55-4.79)	4.24 (2.91-5.84)	4.79 (3.19-6.63)
3-hr	1.02 (0.849-1.23)	1.21 (1.00-1.46)	1.56 (1.29-1.89)	1.90 (1.56-2.30)	2.42 (1.95-3.10)	2.87 (2.24-3.70)	3.37 (2.54-4.43)	3.92 (2.82-5.26)	4.71 (3.25-6.47)	5.36 (3.58-7.38)
6-hr	1.20 (0.997-1.43)	1.39 (1.16-1.67)	1.77 (1.47-2.13)	2.15 (1.77-2.59)	2.75 (2.23-3.51)	3.28 (2.58-4.21)	3.86 (2.93-5.06)	4.52 (3.28-6.05)	5.48 (3.81-7.50)	6.27 (4.22-8.59)
12-hr	1.42 (1.19-1.68)	1.64 (1.37-1.95)	2.07 (1.73-2.46)	2.49 (2.06-2.98)	3.16 (2.58-4.00)	3.75 (2.97-4.77)	4.40 (3.36-5.72)	5.13 (3.75-6.82)	6.20 (4.34-8.43)	7.09 (4.79-9.64)
24-hr	1.67 (1.41-1.97)	1.95 (1.64-2.30)	2.46 (2.07-2.92)	2.95 (2.46-3.50)	3.69 (3.02-4.61)	4.33 (3.44-5.45)	5.03 (3.85-6.46)	5.80 (4.25-7.62)	6.90 (4.85-9.28)	7.80 (5.31-10.5)
2-day	1.95 (1.66-2.29)	2.31 (1.96-2.71)	2.95 (2.49-3.46)	3.51 (2.95-4.14)	4.34 (3.55-5.34)	5.03 (4.00-6.24)	5.76 (4.42-7.30)	6.53 (4.80-8.49)	7.62 (5.38-10.1)	8.49 (5.82-11.4)
3-day	2.14 (1.82-2.49)	2.53 (2.15-2.96)	3.22 (2.73-3.77)	3.82 (3.22-4.49)	4.71 (3.85-5.75)	5.43 (4.33-6.70)	6.19 (4.76-7.81)	6.99 (5.16-9.04)	8.11 (5.75-10.7)	9.00 (6.19-12.0)
4-day	2.29 (1.96-2.67)	2.71 (2.30-3.15)	3.42 (2.90-3.99)	4.05 (3.41-4.74)	4.96 (4.07-6.04)	5.71 (4.56-7.02)	6.49 (5.01-8.17)	7.33 (5.42-9.44)	8.49 (6.03-11.2)	9.41 (6.49-12.5)
7-day	2.69 (2.31-3.11)	3.13 (2.68-3.62)	3.88 (3.31-4.50)	4.55 (3.85-5.29)	5.52 (4.55-6.68)	6.32 (5.08-7.73)	7.16 (5.55-8.95)	8.05 (5.99-10.3)	9.30 (6.64-12.2)	10.3 (7.14-13.6)
10-day	3.04 (2.61-3.51)	3.50 (3.01-4.04)	4.30 (3.68-4.97)	5.00 (4.25-5.81)	6.03 (4.98-7.26)	6.87 (5.54-8.37)	7.76 (6.03-9.66)	8.69 (6.48-11.1)	10.0 (7.17-13.1)	11.0 (7.68-14.6)
20-day	4.02 (3.47-4.60)	4.60 (3.97-5.27)	5.59 (4.80-6.41)	6.43 (5.50-7.40)	7.64 (6.33-9.09)	8.60 (6.96-10.4)	9.60 (7.50-11.8)	10.6 (7.97-13.4)	12.1 (8.69-15.6)	13.2 (9.23-17.3)
30-day	4.83 (4.18-5.50)	5.53 (4.79-6.30)	6.69 (5.77-7.64)	7.67 (6.57-8.79)	9.02 (7.48-10.6)	10.1 (8.16-12.1)	11.1 (8.73-13.6)	12.2 (9.20-15.4)	13.7 (9.90-17.7)	14.8 (10.4-19.4)
45-day	5.86 (5.09-6.64)	6.72 (5.83-7.62)	8.11 (7.01-9.22)	9.24 (7.95-10.5)	10.8 (8.94-12.6)	11.9 (9.68-14.2)	13.1 (10.3-15.9)	14.2 (10.7-17.7)	15.7 (11.4-20.1)	16.8 (11.9-21.9)
60-day	6.75 (5.87-7.62)	7.74 (6.73-8.75)	9.32 (8.08-10.6)	10.6 (9.12-12.0)	12.3 (10.2-14.3)	13.5 (11.0-15.9)	14.7 (11.5-17.7)	15.9 (11.9-19.6)	17.3 (12.6-22.0)	18.4 (13.0-23.9)

¹ Precipitation frequency (PF) estimates in this table are based on frequency analysis of partial duration series (PDS). Numbers in parenthesis are PF estimates at lower and upper bounds of the 90% confidence interval. The probability that precipitation frequency estimates (for a given duration and average recurrence interval) will be greater than the upper bound (or less than the lower bound) is 5%. Estimates at upper bounds are not checked against probable maximum precipitation (PMP) estimates and may be higher than currently valid PMP values. Please refer to NOAA Atlas 14 document for more information.

[Back to Top](#)

PF graphical

PDS-based depth-duration-frequency (DDF) curves

Latitude: 39.0986°, Longitude: -104.7653°

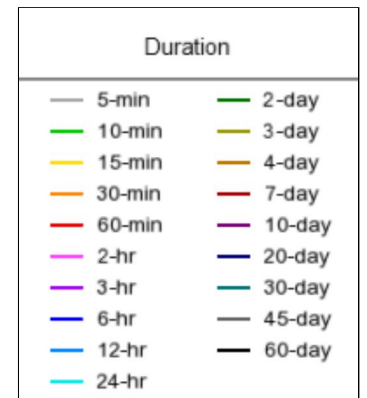
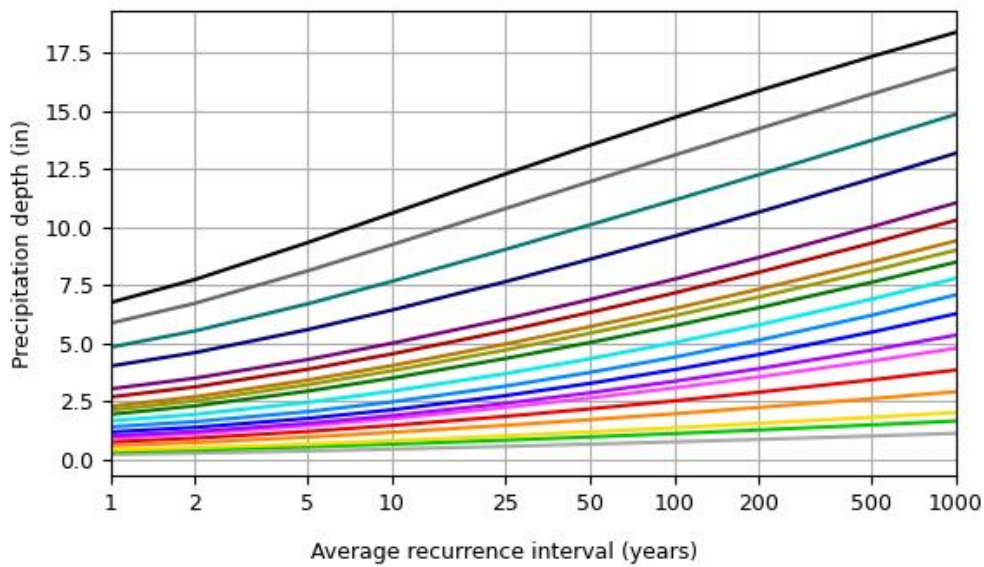
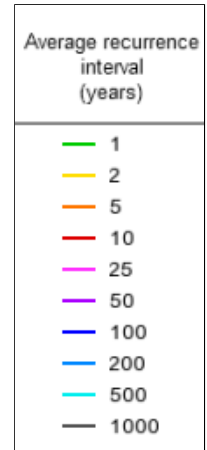
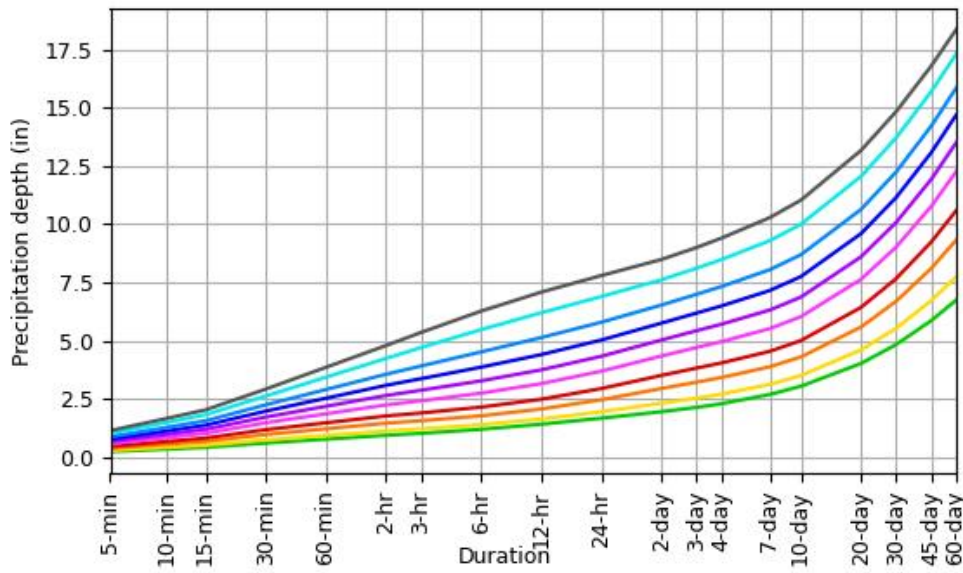

[Back to Top](#)

Maps & aerials

Small scale terrain



[Back to Top](#)

[US Department of Commerce](#)
[National Oceanic and Atmospheric Administration](#)
[National Weather Service](#)
[National Water Center](#)
1325 East West Highway
Silver Spring, MD 20910
Questions?: HDSC.Questions@noaa.gov

[Disclaimer](#)

Historic Flows:

Design Point	Peak Flow						
	Area (ac)	Q ₂ (cfs)	Q ₅ (cfs)	Q ₁₀ (cfs)	Q ₂₅ (cfs)	Q ₅₀ (cfs)	Q ₁₀₀ (cfs)
1	337.1	11.2	39.4	78.5	118.0	188.1	240.8
2	490.5	39.3	73.4	121.5	169.9	256.2	321.3
4	902.7	145.8	234.8	322.2	400.0	527.9	620.0

^a Note that Design Point #3 is an intermediate developed DP not included in the historic model

Developed Flows:

Design Point	Peak Flow							Comparison of Developed to Historic Flow (Q ₁₀₀ %)
	Area (ac)	Q ₂ (cfs)	Q ₅ (cfs)	Q ₁₀ (cfs)	Q ₂₅ (cfs)	Q ₅₀ (cfs)	Q ₁₀₀ (cfs)	
1	342.0	59.8	99.6	139.8	176.3	238.7	285.5	119% (increase)
2	504.7	117.0	189.1	262.6	327.1	432.5	508.9	158% (increase)
3	737.8	187.7	295.8	404.7	501.4	656.3	764.9	
4	902.7	204.0	324.4	445.1	552.4	724.7	845.4	136% (increase)

As detailed in the “Final Drainage Report for Walden Preserve 2 Filing No. 4,” Appendix B includes the HEC-HMS model for detained flows incorporating the calculated outflows from the upgrade of Pond B to full-spectrum detention. The resulting ultimate discharges at downstream Design Point #4 remain at or below historic levels for the full spectrum of design storms:

Detained Flows:

Design Point	Peak Flow Comparison						
	Area (ac)	Q ₂ (cfs)	Q ₅ (cfs)	Q ₁₀ (cfs)	Q ₂₅ (cfs)	Q ₅₀ (cfs)	Q ₁₀₀ (cfs)
4 (Historic)	902.7	145.8	234.8	322.2	400.0	527.9	620.0
4 (Detained)	902.7	139.0	226.7	314.1	391.5	515.3	601.4
Comparison ^a		95%	97%	97%	98%	98%	97%

^a Comparison of Detained Flow / Historic Flow

D. Detention Ponds

The total developed storm runoff downstream of the proposed subdivision will be maintained at historic levels by routing flows through an existing detention pond (Pond B) located along the main tributary channel running through the property, along with ultimate construction of four additional ponds (Rain Gardens C2, C4, and C12, and Detention Pond C8) serving the northern parts of the

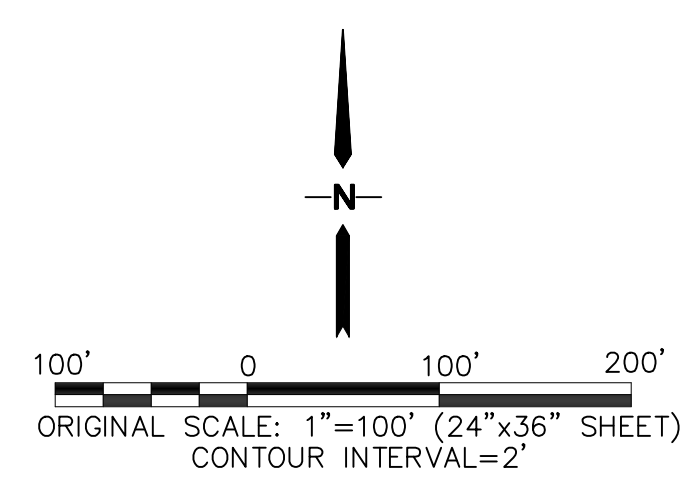
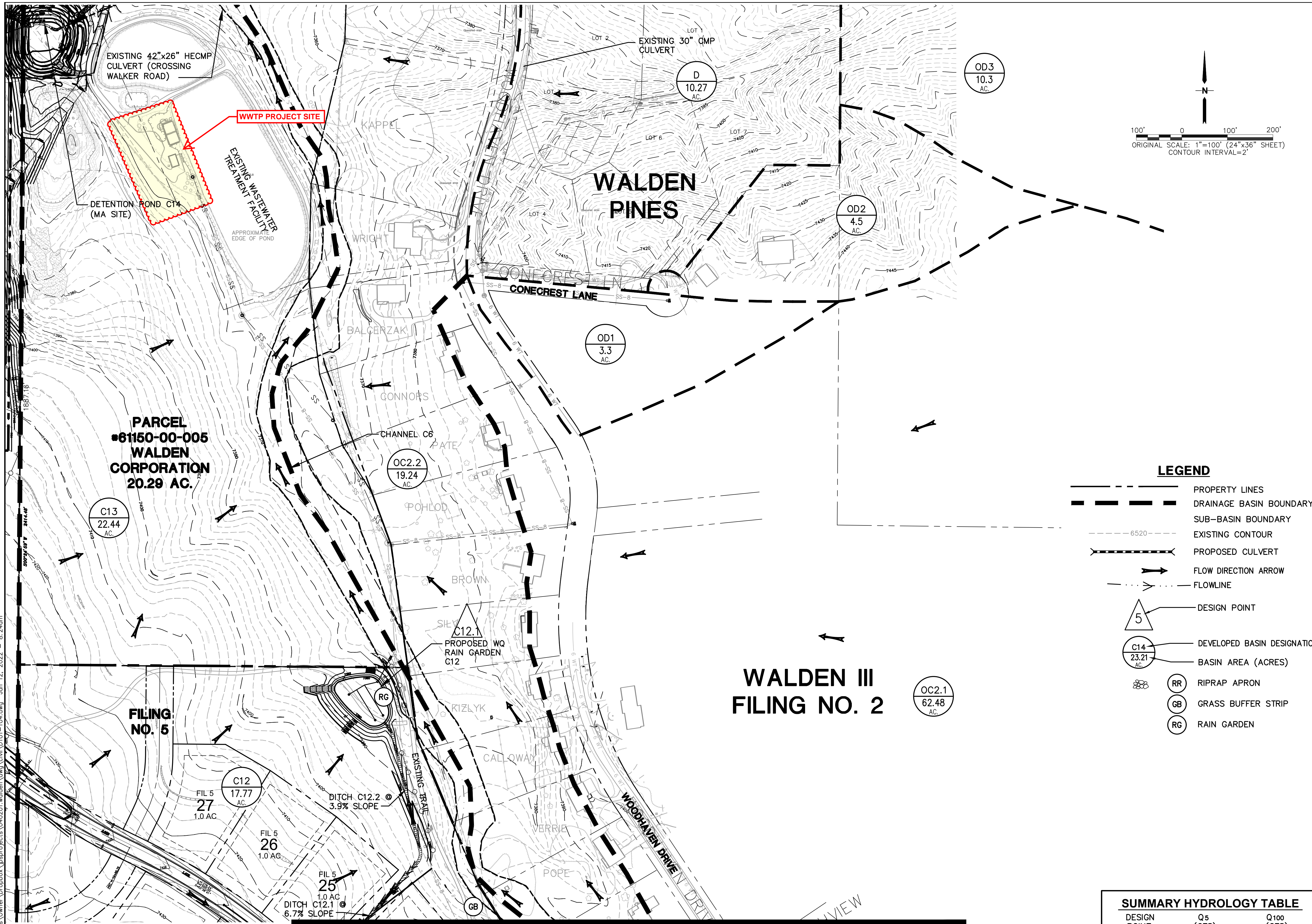

LEGEND

- PROPERTY LINES
- DRAINAGE BASIN BOUNDARY
- SUB-BASIN BOUNDARY
- EXISTING CONTOUR
- PROPOSED CULVERT
- FLOW DIRECTION ARROW
- FLOWLINE
- DESIGN POINT
- DEVELOPED BASIN DESIGNATION
- BASIN AREA (ACRES)
- RIPRAP APRON
- GRASS BUFFER STRIP
- RAIN GARDEN

SUMMARY HYDROLOGY TABLE

DESIGN POINT	Q5 (CFS)	Q100 (CFS)
C12.1	30.5	72.4

WALDEN PRESERVE

DEVELOPED DRAINAGE PLAN

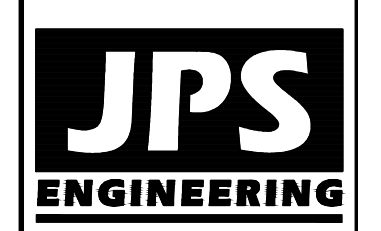

19 E. Willamette Ave.
Colorado Springs, CO 80903
PH: 719-477-9429
FAX: 719-471-0766
www.jpsengr.com



CALL UTILITY NOTIFICATION CENTER OF COLORADO
1-800-922-1987
CALL OR VISIT WWW.COCOLORADO.COM
BEFORE YOU DIG, GRADE, OR EXCAVATE FOR THE MARKING OF UNDERGROUND MEMBER UTILITIES.

No.	REVISION	BY	DATE

HORZ. SCALE: 1"=100'
VERT. SCALE: N/A
SURVEYED: N/A
CREATED: 10/03/11
PROJECT NO: 040201
DRAWN: BJJ
DESIGNED: JPS
CHECKED: JPS
LAST MODIFIED: 11/10/22
MODIFIED BY: BJJ

SHEET: **D1.01**

MATCH LINE - SEE SHEET D1.02

C:\Users\Owner\Desktop\psprojects\040201\walden\dwg\civil\D101-104.dwg Jan. 12, 2022 - 8:24am

WALDEN CORPORATION

PO BOX 1870
MONUMENT CO 80132
719-559-2229
waldencorporation@yahoo.com

February 5, 2026

To Whom It May Concern:

Walden Corporation is the owner of the property associated with the proposed Wastewater Treatment Plant project located on Parcel No. 6115000005. An approximately 3-acre area southwest of the project limits was previously disturbed as part of a material stockpile operation conducted under a separate scope of work. This area lies within the overall property boundary but outside the limits of the current improvements.

As a condition of approval for the Walden Sanitation District Wastewater Treatment Plant project, Walden Corporation agrees to restore this disturbed area prior to construction of the project. Restoration will include regrading the area to pre-stockpile conditions and permanently stabilizing the site to achieve a minimum of 70% vegetative cover, in accordance with the El Paso County Drainage Criteria Manual, Volume 2.

Sincerely,

Bill Dunston
Principal

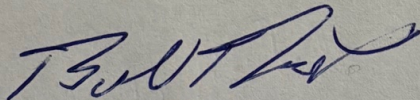

	Project: Walden WWTP
	Location: El Paso County, CO
	Designer: DDK
	Date: 11/10/2025
	Latest Revision: 2/17/2026

¹From Tables 6-2 and 6-3 in UDFCD Volume 1

²From Table 6-5 in UDFCD Volume 1

IMPERVIOUSNESS AND RUNOFF COEFFICIENT CALCULATIONS

Basin Designation	NRCS Hydrologic Soil Group	Total Area (ac)	Total Area (sf)	Roofs & Pavement	Water Surface	Gravel	Undisturbed Open Space	Disturbed Open Space	Percent Impervious	Runoff Coefficients, C ²	
				Impervious % ¹	(sf)	(sf)	(sf)	(sf)		(sf)	C ₅
D1	B	3.93	171,190	95%	6,577	77,130	8,166	79,317	54.84%	0.45	0.68
EX1	B	3.93	171,190	95%	3,152	77,130	5,857	85,051	52.03%	0.42	0.67
EX2	B	12.62	549,939	80%	0	0	21,700	528,239	7.96%	0.05	0.46
EX3	B	2.06	89,800	100%	0	0	5,009	0	23.35%	0.18	0.53
EX4	B	2.77	120,876	80%	1,116	0	0	119,760	5.83%	0.04	0.45
Net Change from EX1 to D1		0.00	0		+3425	0	+2309	-5734	+2.81%	+0.02	+0.01



Project: Walden WWTP
 Location: El Paso County, CO
 Designer: DDK
 Date: 11/10/2025
 Latest Revision: 2/17/2026

NRCS Conveyance Factors, K ²	
Type of Land Surface	K
Heavy Meadow	2.5
Tillage/Field	5
Short Pasture/Lawns	7
Nearly Bare Ground	10
Grassed Waterway	15
Paved Areas	20

¹Max 300 ft in Urban areas and 500 ft in rural areas

²From Table 6-2 in UDFCD Volume 1

Minimum T_c

TIME OF CONCENTRATION CALCULATIONS

Basin Designation	Imperviousness (%)	C _s	Initial/Overland Flow Time, T _i			Channelized Flow/Travel Time, T _t				Time of Concentration, T _c (Check)			
			Length (ft) ¹	Slope (%)	T _i (min)	Land Surface	Length (ft)	Slope (%)	Velocity (ft/sec)	T _t (min)	Computed T _c (min)	First Design Point T _c (min)	Selected T _c (min)
D1	54.84%	0.45	156	4.80	8.79	Short Pasture/Lawns	0	1.20	0.77	0.00	8.79	16.68	8.79
EX1	52.03%	0.42	156	4.80	9.13	Short Pasture/Lawns	0	1.20	0.77	0.00	9.13	17.16	9.13
EX2	7.96%	0.05	300	6.80	17.37	Short Pasture/Lawns	842	5.30	1.61	8.71	26.07	N/A	26.07
EX3	23.35%	0.18	300	2.50	21.35	Short Pasture/Lawns	274	2.40	1.08	4.21	25.57	24.43	24.43
EX4	5.83%	0.04	162	6.70	13.02	Grassed Waterway	233	1.80	2.01	1.93	14.95	N/A	14.95

2.4.1 Initial or Overland Flow Time

The initial or overland flow time, t_i , may be calculated using Equation 6-3:

$$t_i = \frac{0.395(1.1 - C_s)\sqrt{L_o}}{S_o^{0.33}} \quad \text{Equation 6-3}$$

Where:

- t_i = overland (initial) flow time (minutes)
- C_s = runoff coefficient for 5-year frequency (from Table 6-4)
- L_o = length of overland flow (ft)
- S_o = average slope along the overland flow path (ft/ft).

2.4.2 Channelized Flow Time

The channelized flow time (travel time) is calculated using the hydraulic properties of the conveyance element. The channelized flow time, t_t , is estimated by dividing the length of conveyance by the velocity. The following equation, Equation 6-4 (Guo 2013), can be used to determine the flow velocity in conjunction with Table 6-2 for the conveyance factor.

$$t_t = \frac{L_t}{60K\sqrt{S_w}} = \frac{L_t}{60V_t} \quad \text{Equation 6-4}$$

Where:

- t_t = channelized flow time (travel time, min)
- L_t = waterway length (ft)
- S_w = waterway slope (ft/ft)
- V_t = travel time velocity (ft/sec) = $K\sqrt{S_w}$
- K = NRCS conveyance factor (see Table 6-2).

$$T_c = t_i + t_t \quad \text{Equation 6-5}$$

Where:

- T_c = computed time of concentration (minutes)
- t_i = overland (initial) flow time (minutes)
- t_t = channelized flow time (minutes).

2.4.3 First Design Point Time of Concentration in Urban Catchments

Equation 6-4 was solely determined by the waterway characteristics and using a set of empirical formulas. A calibration study between the Rational Method and the Colorado Urban Hydrograph Procedure (CUHP) suggests that the time of concentration shall be the lesser of the values calculated by Equation 6-2 and Equation 6-5 (Guo and Urbanas 2013).

$$t_c = (26 - 17i) + \frac{L_t}{60(14i + 9)\sqrt{S_w}} \quad \text{Equation 6-5}$$

Where:

- t_c = minimum time of concentration for first design point when less than t_c from Equation 6-1.
- L_t = length of channelized flow path (ft)
- i = imperviousness (expressed as a decimal)
- S_w = slope of the channelized flow path (ft/ft).

2.4.4 Minimum Time of Concentration

Use a minimum t_c value of 5 minutes for urbanized areas and a minimum t_c value of 10 minutes for areas that are not considered urban. Use minimum values even when calculations result in a lesser time of concentration.



Project: Walden WWTP
 Location: El Paso County, CO
 Designer: DDK
 Date: 11/10/2025
 Latest Revision: 2/17/2026

Design Storm: 5-Yr
 1-hr Design Point Rainfall (in): 1.22

5-YEAR PEAK RUNOFF CALCULATIONS

Basin Designation	Design Point	Area (ac)	C ₅	C X A	T _c (min)	Intensity (in/hr)	Peak Flow, Q (cfs)
D1	1	3.93	0.45	1.75	8.79	3.47	6.07
EX1	2	3.93	0.42	1.65	9.13	3.42	5.66
EX2	3	12.62	0.05	0.69	26.07	2.08	1.43
EX3	4	2.06	0.18	0.36	24.43	2.15	0.78
EX4	1	2.77	0.04	0.11	14.95	2.77	0.30



Project:	Walden WWTP
Location:	El Paso County, CO
Designer:	DDK
Date:	11/10/2025
Latest Revision:	2/17/2026

Design Storm:	100-Yr
1-hr Design Point Rainfall (in):	2.53

100-YEAR PEAK RUNOFF CALCULATIONS

Basin Designation	Design Point	Area (ac)	C_{100}	$C \times A$	T_c (min)	Intensity (in/hr)	Peak Flow, Q (cfs)
D1	1	3.93	0.68	2.68	8.79	7.19	19.24
EX1	2	3.93	0.67	2.62	9.13	7.09	18.61
EX2	3	12.62	0.46	5.85	26.07	4.31	25.17
EX3	4	2.06	0.53	1.10	24.43	4.47	4.92
EX4	1	2.77	0.45	1.26	14.95	5.75	7.23

Channel Report

Effluent Outfall Ditch

Channel 1

TRAPEZOIDAL

Bottom Width = 1.00 ft
 Side Slope Left, z:1 = 3.00
 Side Slope Right, z:1 = 3.00
 Total Depth = 1.00 ft
 Invert Elevation = 100.00 ft
 Channel Slope = 2.030 %
 Manning's n = 0.035

DISCHARGE

Method = Known Q
 Known Q = 0.39 cfs

CALCULATION SAMPLE

Flow	Depth	Area	Velocity	WP	n-value	Crit Depth	HGL	EGL	Max Shear	Top Width
(cfs)	(ft)	(sqft)	(ft/s)	(ft)		(ft)	(ft)	(ft)	(lb/sqft)	(ft)
0.39	0.18	0.28	1.40	2.14	0.035	0.15	100.18	100.21	0.23	2.08

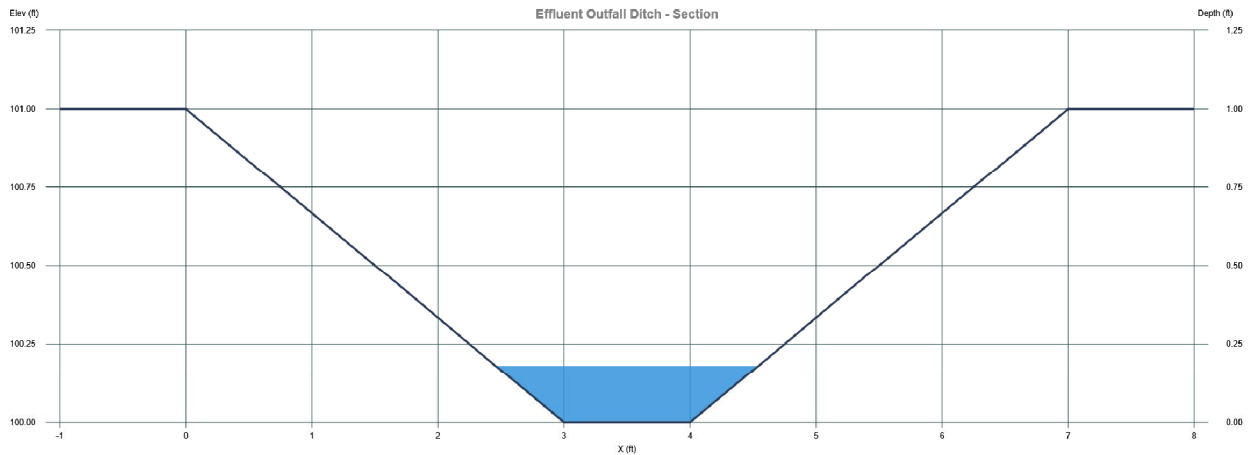

DETERMINATION OF CULVERT HEADWATER AND OUTLET PROTECTION

MHFD-Culvert, Version 4.01 (April 2025)

Project: Walden WWTP
 ID: Effluent Outfall

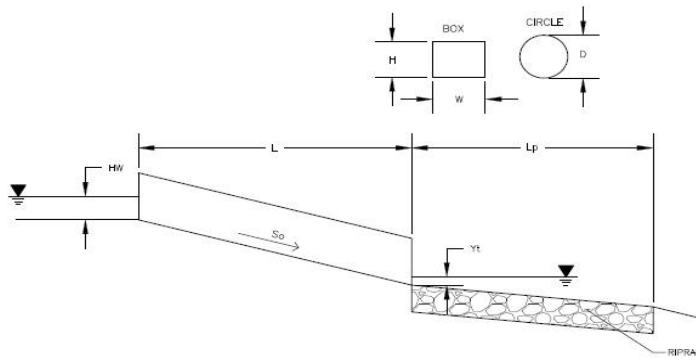

Soil Type:
 Choose One:
 Sandy
 Non-Sandy

Supercritical Flow! Using Adjusted Diameter to calculate protection type.

Design Information:	
Design Discharge	Q = <input type="text" value="0.388"/> cfs
Circular Culvert:	
Barrel Diameter in Inches	D = <input type="text" value="8"/> inches
Inlet Edge Type (Choose from pull-down list)	Beveled Edge (1.5:1)
OR:	
Box Culvert:	
Barrel Height (Rise) in Feet	H (Rise) = <input type="text" value="OR"/> ft
Barrel Width (Span) in Feet	W (Span) = <input type="text" value="OR"/> ft
Inlet Edge Type (Choose from pull-down list)	
Number of Barrels	# Barrels = <input type="text" value="1"/>
Inlet Elevation	Elev IN = <input type="text" value="7352.85"/> ft
Outlet Elevation <u>OR</u> Slope	Elev OUT = <input type="text" value="7351.94"/> ft
Culvert Length	L = <input type="text" value="105"/> ft
Manning's Roughness	n = <input type="text" value="0.012"/>
Bend Loss Coefficient	k _b = <input type="text" value="0"/>
Exit Loss Coefficient	k _x = <input type="text" value="1"/>
Tailwater Surface Elevation	Y _t , Elevation = <input type="text" value=""/> ft
Max Allowable Channel Velocity	V = <input type="text" value="5"/> ft/s
Calculated Results:	
Culvert Cross Sectional Area Available	A = <input type="text" value="0.35"/> ft ²
Culvert Normal Depth	Y _n = <input type="text" value="0.26"/> ft
Culvert Critical Depth	Y _c = <input type="text" value="0.29"/> ft
Froude Number	Fr = <input type="text" value="1.25"/> Supercritical!
Entrance Loss Coefficient	k _e = <input type="text" value="0.20"/>
Friction Loss Coefficient	k _f = <input type="text" value="4.78"/>
Sum of All Loss Coefficients	k _s = <input type="text" value="5.98"/> ft
Headwater:	
Inlet Control Headwater	HW _I = <input type="text" value="0.40"/> ft
Outlet Control Headwater	HW _O = <input type="text" value="N/A"/> ft
Design Headwater Elevation	HW = <input type="text" value="N/A"/> ft
Headwater/Diameter <u>OR</u> Headwater/Rise Ratio	HW/D = <input type="text" value="N/A"/>
Outlet Control Headwater Approximation Method Inaccurate for Low Flow - Backwater Calculations Required	
Outlet Protection:	
Flow/(Diameter ^{2.5})	Q/D ^{2.5} = <input type="text" value="1.07"/> ft ^{0.5} /s
Tailwater Surface Height	Y _t = <input type="text" value="0.27"/> ft
Tailwater/Diameter	Y _t /D = <input type="text" value="0.40"/>
Expansion Factor	1/(2*tan(Θ)) = <input type="text" value="6.63"/>
Flow Area at Max Channel Velocity	A _t = <input type="text" value="0.08"/> ft ²
Width of Equivalent Conduit for Multiple Barrels	W _{eq} = <input type="text" value="-"/> ft
Length of Riprap Protection	L _p = <input type="text" value="2"/> ft
Width of Riprap Protection at Downstream End	T = <input type="text" value="1"/> ft
Adjusted Diameter for Supercritical Flow	Da = <input type="text" value="0.46"/> ft
Minimum Theoretical Riprap Size	d ₅₀ min = <input type="text" value="1"/> in
Nominal Riprap Size	d ₅₀ nominal = <input type="text" value="6"/> in
MHFD Riprap Type	Type = <input type="text" value="VL"/>

V3_ FDR.pdf Markup Summary

EPC Stormwater- Zachary (9)

Manual requires that water quality capture volume (WQCV) development areas of one (1) acre or larger. The direct use of WWTP improvements is approximately 0.39 acres, which does not, by itself, trigger a requirement for on-site WQCV. A 2-acre area southwest of the WWTP limits was identified, which, when combined with the WWTP improvements, would be considered as a single development area. Replicable and permanent stabilization to achieve at least 70% vegetation cover, as required by the WWTP consent decree, and no other stabilization to achieve at least 70% vegetation cover. A plan to be included in the enclosure to document this.

Subject: SW - Highlight
Page Label: 5
Author: EPC Stormwater- Zachary
Date: 4/15/2026 11:43:43 AM
Status:
Color: ■
Layer:
Space:

WWTP improvements is approximately 0.39 acres,

but outside the limits of the proposed improvements and of work. While not part of the current design, as a condition of the permit, the contractor shall be required to stabilize and permanent stabilization to achieve at least 70% vegetation cover. A plan to be included in the enclosure to document this.

Subject: SW - Textbox
Page Label: 5
Author: EPC Stormwater- Zachary
Date: 4/15/2026 11:45:56 AM
Status:
Color: ■
Layer:
Space:

Revise section as necessary after addressing comments in GEC plan

The four on-site
EX1 & D1 –
existing conditions
includes part

Subject: SW - Highlight
Page Label: 6
Author: EPC Stormwater- Zachary
Date: 4/15/2026 11:58:31 AM
Status:
Color: ■
Layer:
Space:

EX1 & D1

EX3 – The
stockpile

Subject: SW - Highlight
Page Label: 6
Author: EPC Stormwater- Zachary
Date: 4/15/2026 11:58:41 AM
Status:
Color: ■
Layer:
Space:

EX3 –



Subject: SW - Textbox with Arrow
Page Label: 6
Author: EPC Stormwater- Zachary
Date: 4/15/2026 11:59:40 AM
Status:
Color: ■
Layer:
Space:

Site development plan shows drain pipes taking flows from these basins north. please revise.

Calculations

Please include the Four-Step Process (ECM Appendix I.7.2.A.)

Subject: SW - Textbox
Page Label: 8
Author: EPC Stormwater- Zachary
Date: 4/15/2026 12:00:36 PM
Status:
Color: ■
Layer:
Space:

Please include the Four-Step Process (ECM Appendix I.7.2.A.)

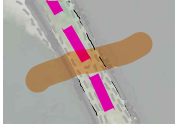

Subject: SW - Highlight
Page Label: [1] 1
Author: EPC Stormwater- Zachary
Date: 4/15/2026 11:50:14 AM
Status:
Color: ■
Layer:
Space:

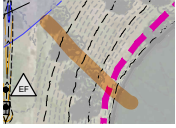

Subject: SW - Highlight
Page Label: [1] 1
Author: EPC Stormwater- Zachary
Date: 4/15/2026 11:50:15 AM
Status:
Color: ■
Layer:
Space:



Subject: SW - Textbox with Arrow
Page Label: [1] 1
Author: EPC Stormwater- Zachary
Date: 4/15/2026 11:51:14 AM
Status:
Color: ■
Layer:
Space:

Site development plan shows pipes that will carry the flows from the pond basins to the north.