



Accepted for File
By: Christina Prete, PE
Stormwater Manager
Date: 11/20/2025 4:36:05 PM
El Paso County Department of Public Works

▶ HRGREEN.COM

Flying Horse Foundation Stormwater Management Plan (SWMP)

October 2025

HR Green Project No: 2502010

El Paso County No. PPR258

Prepared For (Applicant/Owner):

Owner: Jeffrey B. Smith

Owner Representative: Drew Balsick

2138 Flying Horse Club Dr.

Colorado Springs, CO 80921

(719) 785-3237

Prepared By:

HR Green Development, LLC

Contact: Richie Lyon, P.E.

1975 Research Parkway, Suite 160, Colorado Springs, CO 80924

Richie.Lyon@hrgreen.com

(719) 318-0871

Qualified Stormwater Manager:

Name: Adam Doyle

Company: Flying Horse Development, LLC.

Address: 6385 Corporate Drive, Ste. 200, Colorado Springs, CO 80919

Contractor/Operator:

Name: [TBD]

Company: [TBD]

Address: [TBD]



Table of Contents

Table of Contents 1

Engineer’s Statement 3

I. Site Location & Description 4

II. Construction Phasing..... 6

III. Pre-Development Conditions and Soils..... 7

IV. Description of Potential Pollutants..... 7

V. Areas and Volumes 8

VI. Self-Inspections 9

VII. Materials Handling 10

VIII. Spill Prevention & Response Plan..... 11

IX. Implementation of Control Measures..... 12

X. Final Stabilization & Long-Term Stormwater Management Plan..... 14

XI. References 15

Appendices

- A. Vicinity Map & NRCS Soil Survey & FEMA Map
- B. GEC Plans
- C. Calculations
- D. El Paso County Construction Control Measures
- E. Spill Prevention Plan & CDPHE Brochure
- F. SWMP Report Revision Log



▷ **PREPARING ENGINEER:**

Name: Richie Lyon, P.E.

Company: HR Green Development, LLC

Title: Project Manager

Phone Number: (719) 318-0871

Address: 1975 Research Pkwy, Suite 160 Colorado Springs 80920

▷ **PERMITEE:**

Name: Drew Balsick

Company: Flying Horse Development, LLC.

Title: Owner/Developer

Phone Number: (719) 785-3237

Address: 2138 Flying Horse Club Drive, Colorado Springs, CO 80921

▷ **QUALIFIED STORMWATER MANAGER**

Contact: Adam Doyle

Company: Flying Horse Development, LLC.

Title: Construction Manager

Phone Number: 719-331-6174

Address: 6385 Corporate Drive, Ste. 200 Colorado Springs, Colorado 80919

▷ **GEC ADMINISTRATOR:**

Contact: Adam Doyle

Company: Flying Horse Development, LLC.

Title: Construction Manager

Phone Number: 719-331-6174

Address: 6385 Corporate Drive, Ste. 200 Colorado Springs, Colorado 80919



Engineer's Statement

The Stormwater Management Plan was prepared under my direction and supervision and is correct to the best of my knowledge and belief. Said Plan has been prepared according to the criteria established by the County and State for Stormwater Management Plans.

Name: Richard D. Lyon, P.E. Date: 10/2/2025

Phone Number: 719-394-2435

Seal





I. Site Location & Description

Location

The Flying Horse Foundation site is in Section 31, Township 11 South, Range 65 West of the Sixth Principal Meridian, City of Colorado Springs, County of El Paso, State of Colorado. The site is located approximately three quarters of a mile to the southwest of the intersection of Old Stagecoach Road and Black Forest Road. The nearest intersection of Black Forest Road and Country Estates Lane is 0.4 miles to the east of the site. A vicinity map is provided in Appendix A.

Legal Description

FLYING HORSE NORTH FOUNDATION 40AC

A PORTION OF THE NORTH HALF OF THE SOUTHWEST QUARTER OF SECTION 31, TOWNSHIP 11 SOUTH, RANGE 65 WEST OF THE 6TH P.M., COUNTY OF EL PASO, STATE OF COLORADO.

BASIS OF BEARINGS: THE SOUTH LINE OF FLYING HORSE NORTH FILING NO. 4 AS RECORDED UNDER RECEPTION NUMBER 225715505, RECORDS OF EL PASO COUNTY, COLORADO; BEING MONUMENTED AT THE WEST END BY A NO. 5 REBAR AND YELLOW PLASTIC CAP STAMPED "EDWARD-JAMES PLS 33196" AT GROUND LEVEL AND AT THE EAST END BY A NO. 5 REBAR AT GROUND LEVEL, ASSUMED TO BEAR N89°11'15"E A DISTANCE OF 2,327.40 FEET.

COMMENCING AT THE SOUTHWEST CORNER OF FLYING HORSE NORTH FILING NO. 4 AS RECORDED UNDER RECEPTION NUMBER 225715505, SAID POINT BEING THE POINT OF BEGINNING; THENCE N89°11'15"E ON THE SOUTHERLY BOUNDARY LINE OF SAID FLYING HORSE NORTH FILING NO. 4, A DISTANCE OF 378.26 FEET TO THE NORTHWEST CORNER OF COUNTY VIEW ESTATES AS RECORDED UNDER RECEPTION NUMBER 99011204; THENCE S00°01'03"E ON THE WESTERLY BOUNDARY LINE OF SAID COUNTRY VIEW ESTATES A DISTANCE OF 1,332.58 FEET TO A POINT ON THE NORTHERLY BOUNDARY LINE OF PALMER DIVIDED AS RECORDED UNDER RECEPTION NUMBER 205084216; THENCE ON SAID NORTHERLY LINE THE FOLLOWING TWO (2) COURSES:

1. S89°02'33"W A DISTANCE OF 659.21 FEET;
2. S89°25'18"W A DISTANCE OF 478.81 FEET;

THENCE N00°36'14"W A DISTANCE OF 371.29 FEET; THENCE S89°25'03"W A DISTANCE OF 216.02 FEET; THENCE NE40°58'22"W A DISTANCE OF 230.96 FEET TO A POINT ON CURVE; THENCE ON THE ARC OF A CURVE TO THE LEFT WHOSE CENTER BEARS N67°08'52"W, HAVING A DELTA OF 22°00'42", A RADIUS OF 365.00 FEET A DISTANCE OF 140.22 FEET TO A POINT TO TANGENT; THENCE N00°50'26"E A DISTANCE OF 417.47 FEET; THENCE S89°09'34"E A DISTANCE OF 95.48 FEET TO A POINT OF CURVE; THENCE ON THE ARC OF A CURVE TO THE LEFT, HAVING A DELTA OF 65°19'19", A RADIUS OF 365.00 FEET A DISTANCE OF 416.13 FEET TO A POINT ON CURVE; THENCE N89°11'00"E A DISTANCE OF 429.87 FEET; THENCE N00°48'45"W A DISTANCE OF 30.00 FEET TO A POINT ON THE SOUTHERLY BOUNDARY LINE OF FLYING HORSE NORTH FILING NO. 5 AS RECORDED UNDER RECEPTION NUMBER 225715504; THENCE N89°11'15"E ON THE SOUTHERLY BOUNDARY LINE OF SAID FLYING HORSE NORTH FILING NO. 5, A DISTANCE OF 236.32 FEET TO THE POINT OF BEGINNING.

CONTAINING A CALCULATED AREA OF 1,742,743 SQUARE FEET OR 40.008 ACRES.

Description of Property

The Flying Horse Foundation lot is 40.008 acres of the existing 60 acres of 14820 Black Forest Road, County Schedule No. 510000291. The property falls within the East Cherry Creek Basin. Of the total area, 1.6 acres (4.0%) consists of building footprint; 0.3 acres (0.8%) consists of gravel driveway; and 18.3 acres (45.8%) consists of undeveloped land or permeable landscape. There are no existing formal channels or drainageways traversing the site. The stormwater runoff within the areas of proposed disturbance drains two different directions. The vast majority of the disturbed area and final development that will result in an increased imperviousness and net gain in stormwater runoff will drain northwest through the existing Flying Horse North golf course and into the existing Irrigation Pond 13 that was a constructed permanent control measure in Filing No. 1. The disturbance area east of the proposed Foundation building is strictly for demolition of the existing home, driveway reconstruction, and daylight landscaping that does not result in a net gain in stormwater runoff that drains east to an existing natural tertiary drainage channel beginning on the southeast of the site and running northeast through Country View Estates, ultimately through Filing No. 4 and to its permanent control measure of Pond A.

Downstream tertiary swales and the existing ponds were assessed in the Final Drainage Report for the project. Downstream infrastructure and developments will experience no negative impacts due to this development.

Neighboring Areas & Access

The surrounding area to the northeast is the Flying Horse North Filing No. 4 subdivision and the area to the northwest of the site is Filing No. 5, both filings consisting of single family residential lots of 2.5 acres or more. A future filing of the same 2.5 acre minimum area single-family residential lots is planned directly west of the Site. Located to the south of the site is the Palmer Divide subdivision and to the east of the site is the County View Estates subdivision. The Country View Estates and Palmer Divide subdivisions contain 5.0 acre single family residential lots.

The existing gravel driveway entrance within the driveway easement (reception number 099035037) on the northern boundary of the adjacent Country View Estates subdivision from Black Forest Road to the Flying Horse Foundation will become the secondary entrance. The primary entrance to the site will be a gravel driveway connecting the end of Stableford Terrace within Flying Horse North Filing No. 4 to the existing driveway. A third ingress/egress is planned for the future roadway extension of Sandbagger Drive from Filing No. 5 which is to be the future secondary access and the driveway easement from Black Forest Road along Country View Estates will no longer be used.

Construction Activity

The proposed on-site development is to include the construction of the new building, reconstruction of a small area of existing gravel driveway, new gravel driveway due northwest for the future Sandbagger Drive access, fencelines for the horse corral areas, utility service work for water, septic, and electric, and overlot grading for the slab and daylight into the existing landscape.

Temporary control measures such as silt fence and vehicular tracking control will be installed prior to construction. A designated stabilized staging area and stockpile management area are shown on the GEC plans. Temporary drainage swales and a temporary sediment basin installed prior to construction will be utilized to collect and control stormwater runoff and sediment during construction activities for disturbed areas. Once final stabilization is achieved, temporary erosion control measures will be removed.

Construction starts with setting up perimeter controls which are prescribed to be silt fence surrounding the downstream areas of disturbance for overlot grading as well as the surrounding designated stockpile and staging areas. On-site grading includes preparing for a foundation pad for the proposed pole barn, the associated daylight grading to the existing ground, and adjustment to the existing driveway. Daylight grading will follow the same drainage pattern as historical with stormwater flows away from the proposed structure. The future access from a future roadway extension of Sandbagger Drive from Filing No. 5 is shown for the ultimate condition but is not to be constructed until that filing is approved and constructed. Upon completion of grading, erosion control blanket is to be installed in the prescribed areas of higher slopes (>4:1) which are mostly daylight landscape areas at the perimeter of the grading envelope.

Construction will be completed with final stabilization including permanent seeding and mulching per the GEC plan set. The only off-site construction planned is for the primary driveway construction within the Flying Horse North Filing No. 4 Tract F.

II. Construction Phasing

Phasing and Sequence Schedule

The proposed sequence of major construction activities and Construction Control Measures for the project as are follows:

1. Install perimeter erosion and stormwater control measures (i.e. VTC, SSA, SP, TSB, ST, and SF). (Fall of 2025)
2. Grade site for improvements. Install ECB per GEC plans. (Fall of 2025)
3. Construction of pole barn riding arena. (Fall and Winter of 2025)
4. Landscaping, restoration and final stabilization. Ensure final stabilization achieved prior to site closure. (Spring of 2026)
5. Remove construction BMPs (Springs of 2026)

Construction Documentation

Construction drawings are provided with this document showing the Grading and Erosion Control plan for this project and are intended to be a “living” document used by the SWMP Manager to document construction activities. See Appendix F for record log.

III. Pre-Development Conditions and Soils

Floodway

According to the current FEMA Flood Insurance Rate Maps FEMA FIRM 08041C0315G, effective December 7, 2018, this site is designated as Zone X (outside 0.2% chance of flood). See Appendix A for FEMA FIRM Exhibit.

Existing Vegetation

The existing vegetative cover is approximately 90 percent as evidenced by a field survey and aerial imagery. The existing vegetation includes native grasses and weeds, and shrubs. There are some disbursed trees near the existing buildings on the site and near the fenceline to the east.

Existing Drainage Patterns

The existing site conditions are such that the developed area with existing structures and barns generally drains due east into the existing tertiary swale within Country View Estates that flows into a private 18 inch HDPE culvert that outlets to Flying Horse North Filing No. 4 and ultimately into Pond A of Filing 4. Stormwater runoff from the remaining west part of the site that is undeveloped drains off-site to undeveloped land and the golf course and ultimately to Irrigation Pond 13 within Filing No. 1. The stormwater outfall from the site is not in the vicinity of and is not directly connected to outfall locations into the ultimate downstream waterway, East Cherry Creek, which is located approximately 1.2 miles east of the boundary of the Flying Horse Foundation. There are no stream crossings located in within the construction boundary.

Existing Slopes

The Flying Horse Foundation area consists of varied slopes between 1% and 15%. The site generally slopes from the high point located at the central southern part of the Site and drains northwest and east-northeast as two major basins.

Soils

According to the US Department of Agriculture Natural Resources Conservation Service Soil Survey of El Paso County, Colorado, the primary soils through the site area are Peyton-Pring complex and Peyton sandy loam. This soil type within the site is within Hydrologic Soil Group B. Runoff coefficients for this study were selected based on "A/B" type soils. This agrees with the MDDP report for Flying Horse North which also identified these soil classifications and hydrologic soil groups for the area. A copy of the soil map for the site can be found in Appendix A.

The existing soil types have a slight potential for erosion which can be mitigated by employing appropriate downstream construction control measures before/during/after construction to limit potential impacts to stormwater discharges. The potential impacts are sediment discharge into the existing stormwater conveyance system.

IV. Description of Potential Pollutants

Construction activities can produce a variety of pollutants that can potentially cause stormwater contamination. Grading activities remove rocks, vegetation and other erosion controlling surfaces and can result in the exposure of underlying soil to the elements, which can then be displaced into water sources. Potential sources

of sediment to stormwater runoff include earth moving activities associated with site grading, replacement of off-site storm culvert pipes, and landscaping. Wind and erosion and vehicular transport can also produce sediment debris.

Potential pollutants and sources other than sediment to stormwater runoff include trash, debris, fueling and equipment failure. Materials of significance stored on the project site include sediment, concrete washout, trash & debris, fuels and oils.

Discharges of concrete washout water to the ground is an allowable non-stormwater discharge that is to be controlled with concrete washout areas. There are no other non-stormwater discharges anticipated from the site.

Potential sources of pollution from construction activities include

1. Disturbed or stored soils
2. Vehicle tracking of sediment
3. Loading & unloading operations
4. Outdoor storage activities
5. Vehicle and equipment maintenance/fueling
6. Dust or particulate generating processes
7. Routine maintenance activities involving fertilizers, pesticides, detergents, fuels, solvents etc.
8. On-site waste management (waste piles, liquid wastes, dumpsters)
9. Concrete truck/equipment washing (washing truck chute and associated fixtures)
10. Non-industrial waste (worker trash and portable toilets)

V. Areas and Volumes

The total limits of construction/disturbance is 8.8 acres which is the limit of disturbance per the Grading and Erosion Control Plan. The limit of disturbance includes areas of grading modifications on site and areas for staging and stockpiling and utility service installations for the private OWTS and water infrastructure.

Below are construction earthwork figures.

Earthwork Analysis with 15% Compaction Factor

Cut Quantity (adjusted):	20,069 cubic yards
Fill Quantity (adjusted):	16,082 cubic yards
Net (adjusted):	3,987 cubic yards CUT/EXPORT

Earthwork Analysis with No Compaction Factor

Cut Quantity (unadjusted):	20,069 cubic yards
Fill Quantity (unadjusted):	13,984 cubic yards
Net (unadjusted):	6,084 cubic yards CUT/EXPORT

VI. Self-Inspections

Self-inspections of the Construction Control Measures must be completed by the certified GEC Administrator. The below provides the minimum to satisfy the El Paso County self-inspection requirements. A more frequent self-inspection schedule may be required to ensure Control Measures are operating in compliance with the approved GEC plan.

1. Inspection Schedules:

- a. The GEC Administrator shall make a thorough inspection of the Control Measures:
 - i. At least once every fourteen (14) calendar days.
 - ii. Within 24 hours following any precipitation event (i.e. rain, snow, hail etc.) that causes surface erosion.
 - Alternatively, the GEC Administrator can perform a thorough inspection of the Control Measures once every seven (7) days and forego post-precipitation inspections.
- b. For sites where construction activities have completed and final stabilization measures installed but final stabilization has not yet been achieved, the GEC Administrator shall make a thorough inspection of the Control Measures:
 - i. At least once every 30 days
 - ii. Within 72 hours following any precipitation event that causes surface erosion

2. Inspection Procedures:

- a. Site Inspection & Observation Items:
 - i. Limits of disturbance perimeter and stormwater discharge points
 - ii. All disturbed areas to ensure necessary Construction Control Measures are in place to control potential stormwater runoff.
 - iii. Areas used for material/waste storage.
 - iv. Any areas having a signification potential for storm water pollution (i.e. site entrances, concrete washout areas etc.)
 - v. All Construction Control Measures identified on the GEC plans.
- b. Inspection Requirements:
 - i. Determine any locations, or potential locations, where pollutants and stormwater may be exiting the site/entering the receiving waters.
 - ii. Evaluate Construction Control measures and determine if they are constructed in accordance with the latest revision of the approved GEC plan and operating effectively.
 - iii. Provide recommendations for the need of additional Construction Control measures and the maintenance of existing measures in disrepair to ensure complication with the El Paso County Stormwater Construction Manual.
- c. Construction Control Measure Maintenance/Replacement:
 - i. The GEC administrator shall ensure sediment has been removed from perimeter controls and relocated to an area without the potential for sediment to discharge from the site
 - ii. The GEC administrator shall ensure diversion ditches and temporary sediment ponds have not accumulated excess sediment that impedes their functionality.
 - iii. The GEC administrator shall ensure that failed Control Measures are repaired/reinstalled within three (3) calendar days, according to the El Paso County Stormwater Control

Measure details, to ensure pollutants and/or sediment do not discharge from the site.
GEC details are provided in Appendix D.

- d. Documentation:
 - i. Update the GEC plan to document the installation/revision of Control Measures
 - ii. Identify Control Measure deficiencies and that noncompliance is resolved within three (3) calendar days.
 - iii. Identify Self-Inspection schedule in most recent inspection form
 - iv. Complete and submit Self-Inspection forms within five (5) business days of the completed inspection. Forms are to be accessible and available on-site or electronically until ESQCP termination.
 - v. Ensure Self-Inspections are available, either physically or electronically, throughout the duration of the project. The documents to be available and accessible throughout the duration of the project include the entire Stormwater Management Plan report, the Grading and Erosion Control Plans, and the Self-Inspection Reports.
 - vi. Self-Inspection Report shall contain at least the following:
 - Inspection Date
 - Name and title of the GEC Administrator performing inspection
 - Location(s) of illicit discharges of stormwater, sediment or pollutants from the site
 - Location(s) of Construction Control Measures in need of maintenance/repair
 - Location(s) of Construction Control Measures that failed to operate as designed or proved inadequate
 - Location(s) of additional Construction Control Measures not shown on the latest, approved revision of the GEC plan
 - Any deviations from the minimum inspection schedule
 - Signature of GEC Administrator

VII. Materials Handling

1. General Materials Handling Practices:
 - a. Potential pollutants shall be stored and used in a manner consistent with the manufacturer's instructions in a secure location. To the extent practical, material storage areas should be located away from storm drain inlets and should be equipped with covers, roofs or secondary containment as required to prevent stormwater from contacting stored materials. Chemicals that are not compatible shall be stored in segregated areas so that spill materials cannot combine and react.
 - b. Disposal of materials shall be in accordance with the manufacturer's instructions and applicable local, state, and federal regulations.
 - c. Materials no longer required for construction shall be removed from the site as soon as possible.
 - d. Adequate garbage, construction waste, and sanitary waste handling and disposal facilities shall be provided as necessary to keep the site clear of obstruction and Control Measures clear and functional.
2. Specific Materials Handling Practices:

- a. All pollutants, including waste materials and demolition debris, that occur onsite during construction shall be handled in a way that does not contaminate stormwater.
- b. All chemicals including liquid products, petroleum products, water treatment chemicals, and wastes stored onsite shall be covered and protected from vandalism.
- c. Maintenance, fueling, and repair of all equipment and vehicles involving oil changes, hydraulic system drain down, degreasing operation, fuel tank drain down and removal, and other activities which may result in the accidental release of contaminants, shall be conducted under cover during wet weather and on an impervious surface to prevent release of contaminants onto the ground. Materials spilled during maintenance operations shall be cleaned up immediately and properly disposed of.
- d. Wheel wash water shall be settled and discharged onsite by infiltration.
- e. Application of agricultural chemicals, including fertilizers and pesticides, shall be conducted in a manner and at application rates that will not result in loss of chemical to stormwater runoff. Follow manufacturer's recommendations for application rates and procedures.
- f. pH-modifying sources shall be managed to prevent contamination of runoff and stormwater collected onsite. The most common sources of pH-modifying materials are bulk cement, cement kiln dust (CKD), fly ash, new concrete washing and curing waters, waste streams generated from concrete grinding and sawing, exposed aggregate processes, and concrete pumping and mixer washout waters.

VIII. Spill Prevention & Response Plan

Spills shall be reported per the CDPHE *Environmental Spill Reporting* brochure, provided in Appendix F.

1. The primary objective in responding to a spill is to quickly contain the material and prevent or minimize their mitigation into stormwater runoff and conveyance systems. If the release has impacted onsite stormwater, it is critical to contain the released materials onsite and prevent their release into receiving waters.
2. Spill Response Procedures:
 - a. Notify site superintendent immediately when a spill, or the threat of a spill, is observed. The superintendent shall assess the situation and determine the appropriate response.
 - b. If spills represent an imminent threat of escaping onsite facilities and entering the receiving waters, site personnel shall respond immediately to contain the release and notify the superintendent once the situation has stabilized.
 - c. The site superintendent shall be responsible for completing a spill reporting form and for reporting the spill to the appropriate agency. Any chemical spills and releases are to be reported per the State's CDPHE instructions and guidelines provided in Appendix E.
 - d. Spill response equipment shall be inspected and maintained as necessary to replace any materials used in spill response activities.
3. Spill kits shall be on-hand at all fueling sites. Spill kit locations shall be reported to the GEC administrator.
4. Absorbent materials shall be on-hand at all fueling areas for use in containing advertent spills. Containers shall be on-hand at all fueling sites for disposal of used absorbents.
5. Recommended components of spill kits include the following:
 - a. Oil absorbent pads

- b. Oil absorbent booms
 - c. 55-gallon drums
 - d. 9-mil plastic bags
 - e. Personal protective equipment including gloves and goggles
6. Concrete wash water: unless confined in a pre-defined, bermed containment area, the cleaning of concrete truck delivery chutes is prohibited at the job site.
7. Notification procedures:
- a. In the event of an accident or spill, the GEC administrator shall be notified.
 - b. Depending on the nature of the spill and material involved, the Colorado Department of Public Health and Environment, downstream water users, or other agencies may also need to be notified.
 - c. Any spill of oil which 1) violates water quality standards, 2) produces a “sheen” on a surface water, or 3) causes a sludge or emulsion, or any hazardous substance release, or hazardous waste release which exceeds the reportable quantity, must be reported immediately by telephone to the National Response Center Hotline at (800) 424-8802.

There are no dedicated batch plants proposed as a part of this project and therefore are not a source of pollution requiring spill prevention and response.

IX. Implementation of Control Measures

Stormwater control measures must be installed according to El Paso County design specifications, presented in Appendix D, and the approved Grading and Erosion Control plan this report supports. Within the context of this SWMP’s construction activities the following control measures, at a minimum, are required:

- Silt Fence
 - Silt fence is to be installed at the initial construction phase downstream of planned disturbed areas of the project. The silt fence acts as a barrier and prevents sediment from running offsite from the project disturbed area.
- Vehicle Tracking Control
 - Vehicle Tracking Control is required for the ingress/egress areas of the project for large construction vehicles to access the site with minimal disturbance to existing infrastructure and pavement. The VTC also assists in debris removal from vehicles prior to exiting the site. The control measure is to be installed at the initial construction phase.
- Stabilized Staging Area
 - A designated stabilized staging area is required for equipment staging at the initial construction phase. This area is to be sufficient in size and relatively flat to prevent erosion and sediment runoff when handling materials and maneuvering vehicles. Perimeter controls of the SSA are recommended as localized erosion and sediment control of this area.
- Stockpile Management
 - A designated stockpile area is required for dirt and debris containment at the initial construction phase. This area is to have perimeter controls for localized erosion and sediment control. Frequent export haul is recommended to maintain a minimal stockpile size and minimize sediment runoff during rain events during construction activities.

- Erosion Control Blanket
 - Erosion Control Blanket is to be installed on disturbed slopes of 3:1 or greater to stabilize these areas for permanent stabilization in future construction phases. The erosion control blanket remains in place from the time of disturbance and establishment of the slope in perpetuity as natural degradation of the control measure will occur over time. Any disturbance of the blanket itself requires replacement to ensure stabilization of the slope.
- Diversion Ditches (Earth Dikes & Drainage Swales)
 - Diversion Ditches proposed within this project scope include drainage swales that outfall to temporary sediment basins. The drainage swales are to be maintained throughout the initial construction phase to ensure that the temporary sediment basins are capturing the tributary area they are designed to during rain events.
- Temporary Sediment Basins
 - Temporary Sediment Basins are to be constructed at the initial construction phase which includes earthwork disturbance and results in sediment runoff for stormwater attenuation. The TSB is designed to capture sediment runoff during this phase to minimize sediment runoff directly offsite. Sizing calculation is provided in Appendix C.
- Sediment Trap
 - Sediment Traps are to be constructed at the initial construction phase which includes earthwork disturbance and results in sediment runoff for stormwater attenuation. The ST is designed to capture discharge and allow settling of sediment to minimize sediment runoff directly offsite.
- Seeding & Mulching
 - Seeding and mulching is proposed as a temporary construction phase control measure for slope stabilization and restoration of disturbed areas to remain pervious areas. Permanent seeding and mulching is included in the final construction phase as a permanent stabilization method to stabilize disturbed areas and provide vegetation.
- Concrete Washout Areas
 - Concrete Washout Areas are to be established at the initial construction phase as designated concrete washouts per MHFD details. The designated are to be monitored to ensure that effluent does not overflow or drain out of the excavation. Removal of materials is to take place prior to deconstruction and fill of the CWA.

Additional control measures may be required at the discretion of the County Stormwater Inspector.

Site specific off-site soil tracking is to be mitigated via Vehicle Tracking Control measures. Perimeter control measures are to be inspected and maintained as required to reduce sediment runoff.

Temporary stabilization measures must be implemented for earth disturbing activities on any portion of the site where ground disturbing construction activity has permanently ceased or temporarily ceased for more than 14 calendar days. There are no specified temporary stabilization measures to be used on any disturbed areas inactive for 14 or more calendar days.

There are no stormwater construction control measures specified beyond what is shown on the Grading and Erosion Control Plan. There are no specified stormwater control measures for waste disposal and off-site soil tracking beyond the area of disturbance/construction shown and the CCM's within it.

X. Final Stabilization & Long-Term Stormwater Management Plan

1. Temporary seeding and mulching will be installed to provide interim stabilization prior to final landscaping installation. Final stabilization will be achieved at time of final landscaping. Final stabilization is met when vegetative cover density is to 70% of pre-disturbance levels, not including noxious weeds. Long-term stormwater management will be provided in the offsite, private, full spectrum detention pond, Pond A, located downstream of the site to the northeast within Flying Horse North Filing No. 4. Final stabilization must be achieved prior to removal of temporary stormwater control measures. Anticipated date of final stabilization is Fall 2025; however, this is subject to change.

See below for seeding and mulching details:

- a. Prior to seeding, fill any eroded rills and gullies with topsoil.
 - b. Ensure all areas are seeded and mulched per the County Stormwater Construction Manual.
 - c. Continue monthly self-inspections of final stabilization methods and the stormwater management system to ensure proper function. If repairs are needed, reseed and re-mulch as needed.
 - d. Control noxious weeds in a manner acceptable to the GEC inspector.
 - e. Seed Mix: See Appendix D for approved seed mixes.
 - f. Seeding Requirements:
 - i. Drill seed whenever possible, seed depth must be $\frac{1}{3}$ to $\frac{1}{2}$ inch when drill-seeding. Cross drilling should be used whenever possible with the seed divided between the two operations. The second drilling should be perpendicular to the first.
 - ii. When drill seeding is not possible or on slopes greater than 3:1, hydro-seeding with tackifier may be substituted at the discretion of the GEC inspector. Hydro-seeding must be lightly raked into soil. Seeding rates are presented in Appendix D.
 - iii. All seeded areas must be mulched.
 - g. Mulching Requirements:
 - i. Mulching shall be completed as soon as practical after seeding but no more than fourteen (14) days after planting. Erosion control blanket can be used in place of the below mulching methods.
 - ii. Hay or straw mulch:
 1. Only certified weed-free and certified-seed free mulch may be used. Must be applied at 2 tons/acre and adequately secured.
 2. Crimping shall not be used on slopes greater than 3:1, tackifier must be used in place.
 - iii. Hydraulic mulching:
 1. Allowable on steep slopes or areas with limited access
 2. If hydro-seeding is used, mulching must be applied secondly.
 3. Wood cellulose fibers mixed with water must be applied at a rate of 2,000-2,500 lbs/acre, and tackifier applied at a rate of 100 lbs/acre.
2. The project control measures are to be owned and maintained by the Developer or their assigns (General Contractor, GEC Administrator).
 3. This Stormwater Management Plan Report is a living document that is to be continuously reviewed and modified as part of the overall process of evaluating and managing stormwater quality issues at the site.

The Qualified Stormwater Manager shall amend the SWMP when there is a change in design, construction, or operations and maintenance of the site which would require the implementation of new or revised control measures or if the SWMP proves to be ineffective in achieving the general objectives of controlling pollutants in stormwater discharges associated with the construction activity when control measures are no longer necessary and are removed.

4. The Qualified Stormwater Manager shall maintain a record of amendments made to the SWMP that includes the date and identification of the changes.

XI. References

El Paso County – Drainage Criteria Manual, latest revision October 31, 2018

El Paso County – Engineering Criteria Manual, latest revision October 14, 2020

Mile High Flood District Urban Storm Drainage Criteria Manual Volumes 1, 2, and 3; latest revisions



Flying Horse Foundation
Stormwater Management Plan
Project No.: 2502010
El Paso County, Colorado

APPENDIX A – VICINITY MAP & NRCS SOIL SURVEY & FEMA MAP



VICINITY MAP
FLYING HORSE FOUNDATION

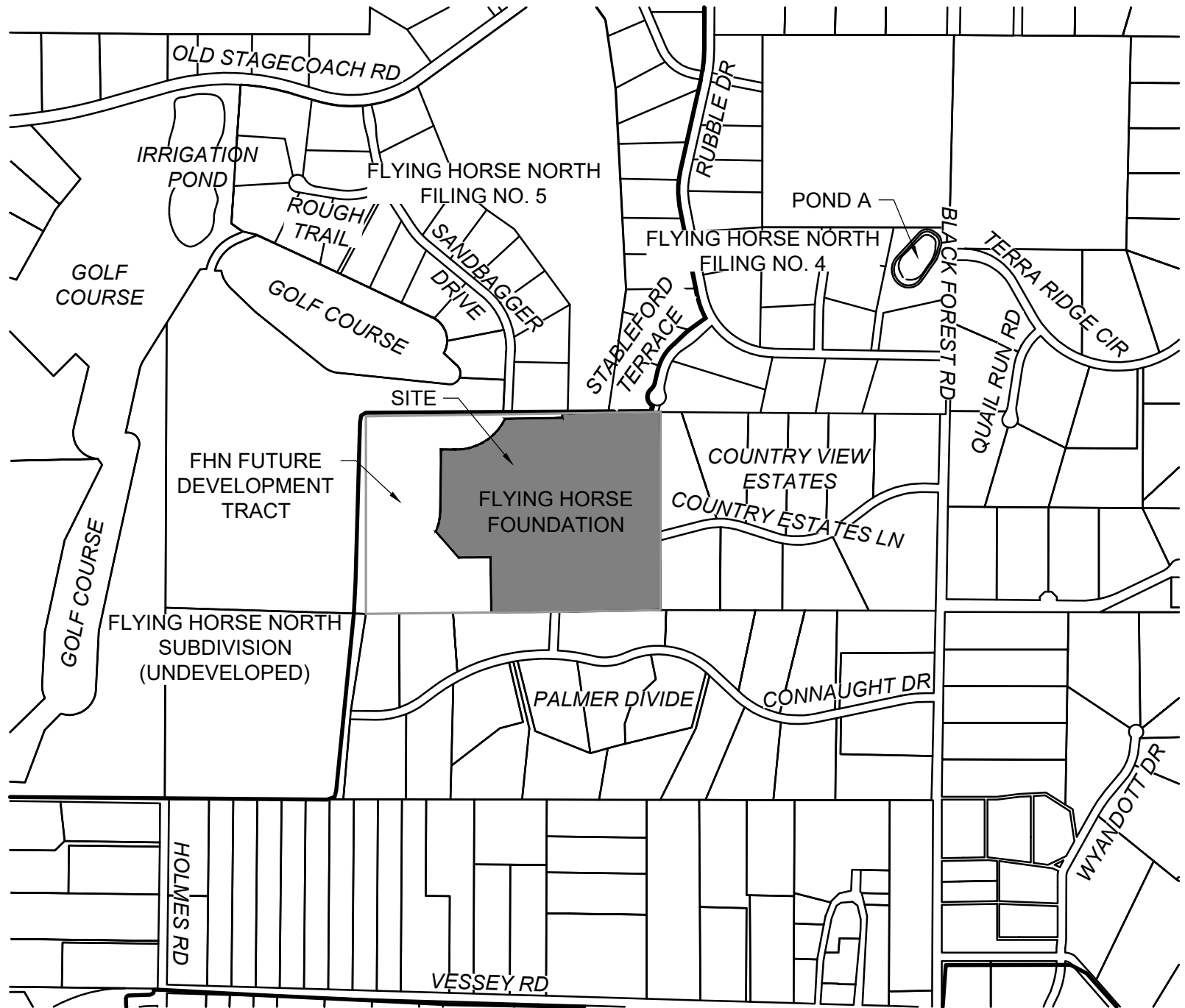

N.T.S.

Hydrologic Soil Group—El Paso County Area, Colorado
(Flying Horse Foundation)

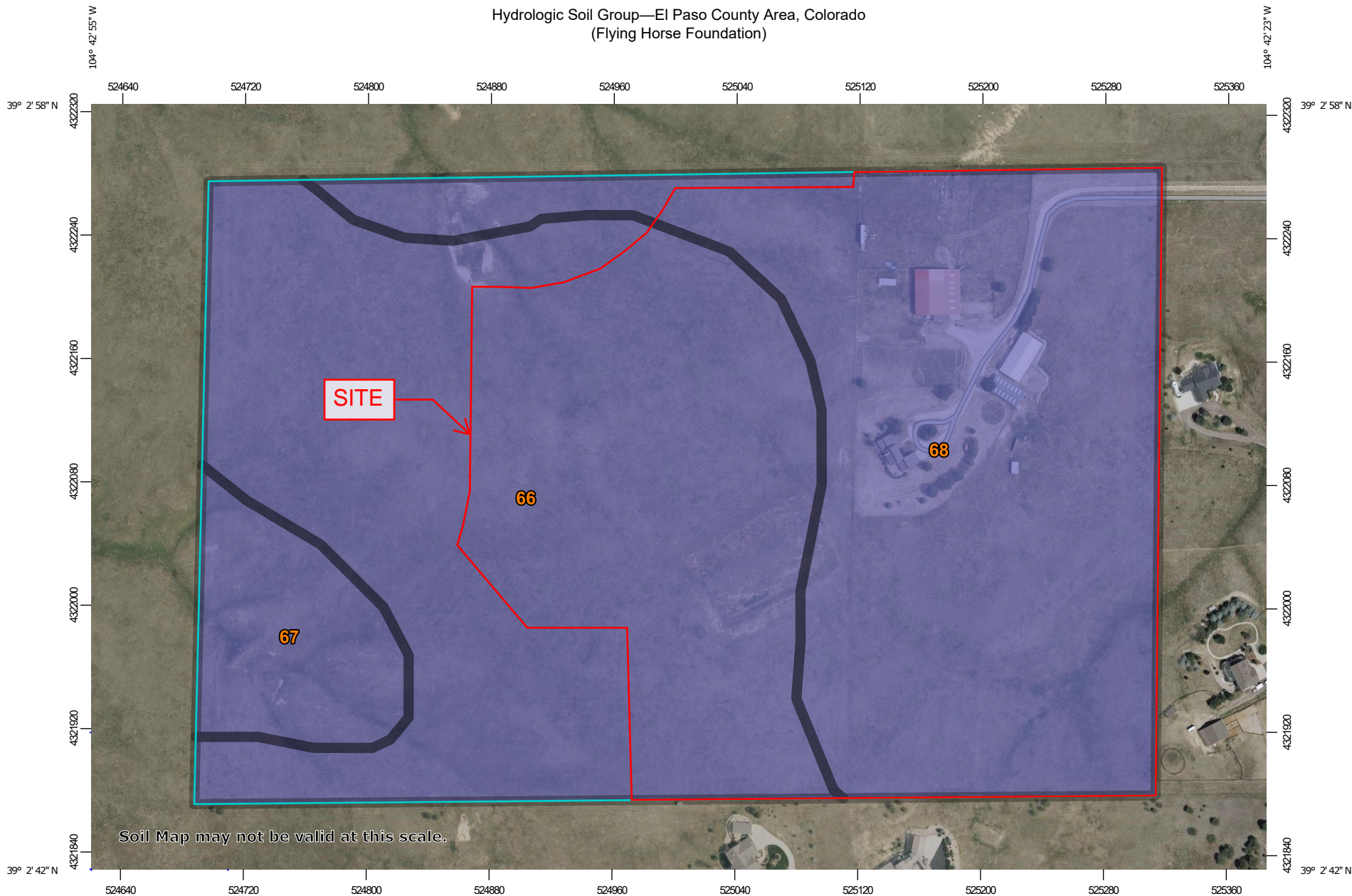

Map Scale: 1:3,500 if printed on A landscape (11" x 8.5") sheet.

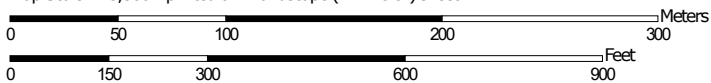

Map projection: Web Mercator Corner coordinates: WGS84 Edge tics: UTM Zone 13N WGS84



MAP LEGEND

Area of Interest (AOI)









 Area of Interest (AOI)

Soils

Soil Rating Polygons





 A
 A/D
 B
 B/D
 C
 C/D
 D
 Not rated or not available

Soil Rating Lines

 A
 A/D
 B
 B/D
 C
 C/D
 D
 Not rated or not available

Soil Rating Points



 A
 A/D
 B
 B/D

 C
 C/D
 D
 Not rated or not available

Water Features

 Streams and Canals

Transportation

 Rails
 Interstate Highways
 US Routes
 Major Roads
 Local Roads

Background

 Aerial Photography

MAP INFORMATION

The soil surveys that comprise your AOI were mapped at 1:24,000.

Warning: Soil Map may not be valid at this scale.

Enlargement of maps beyond the scale of mapping can cause misunderstanding of the detail of mapping and accuracy of soil line placement. The maps do not show the small areas of contrasting soils that could have been shown at a more detailed scale.

Please rely on the bar scale on each map sheet for map measurements.

Source of Map: Natural Resources Conservation Service
 Web Soil Survey URL:
 Coordinate System: Web Mercator (EPSG:3857)

Maps from the Web Soil Survey are based on the Web Mercator projection, which preserves direction and shape but distorts distance and area. A projection that preserves area, such as the Albers equal-area conic projection, should be used if more accurate calculations of distance or area are required.

This product is generated from the USDA-NRCS certified data as of the version date(s) listed below.

Soil Survey Area: El Paso County Area, Colorado
 Survey Area Data: Version 23, Aug 29, 2025

Soil map units are labeled (as space allows) for map scales 1:50,000 or larger.

Date(s) aerial images were photographed: Jul 23, 2024—Aug 4, 2024

The orthophoto or other base map on which the soil lines were compiled and digitized probably differs from the background imagery displayed on these maps. As a result, some minor shifting of map unit boundaries may be evident.

Hydrologic Soil Group

Map unit symbol	Map unit name	Rating	Acres in AOI	Percent of AOI
66	Peyton sandy loam, 1 to 5 percent slopes	B	32.3	51.5%
67	Peyton sandy loam, 5 to 9 percent slopes	B	4.4	7.0%
68	Peyton-Pring complex, 3 to 8 percent slopes	B	26.0	41.5%
Totals for Area of Interest			62.7	100.0%

Description

Hydrologic soil groups are based on estimates of runoff potential. Soils are assigned to one of four groups according to the rate of water infiltration when the soils are not protected by vegetation, are thoroughly wet, and receive precipitation from long-duration storms.

The soils in the United States are assigned to four groups (A, B, C, and D) and three dual classes (A/D, B/D, and C/D). The groups are defined as follows:

Group A. Soils having a high infiltration rate (low runoff potential) when thoroughly wet. These consist mainly of deep, well drained to excessively drained sands or gravelly sands. These soils have a high rate of water transmission.

Group B. Soils having a moderate infiltration rate when thoroughly wet. These consist chiefly of moderately deep or deep, moderately well drained or well drained soils that have moderately fine texture to moderately coarse texture. These soils have a moderate rate of water transmission.

Group C. Soils having a slow infiltration rate when thoroughly wet. These consist chiefly of soils having a layer that impedes the downward movement of water or soils of moderately fine texture or fine texture. These soils have a slow rate of water transmission.

Group D. Soils having a very slow infiltration rate (high runoff potential) when thoroughly wet. These consist chiefly of clays that have a high shrink-swell potential, soils that have a high water table, soils that have a claypan or clay layer at or near the surface, and soils that are shallow over nearly impervious material. These soils have a very slow rate of water transmission.

If a soil is assigned to a dual hydrologic group (A/D, B/D, or C/D), the first letter is for drained areas and the second is for undrained areas. Only the soils that in their natural condition are in group D are assigned to dual classes.

Rating Options

Aggregation Method: Dominant Condition

Component Percent Cutoff: None Specified

Tie-break Rule: Higher

National Flood Hazard Layer FIRMette



104°42'52"W 39°3'5"N

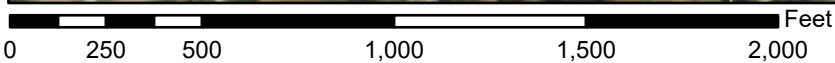
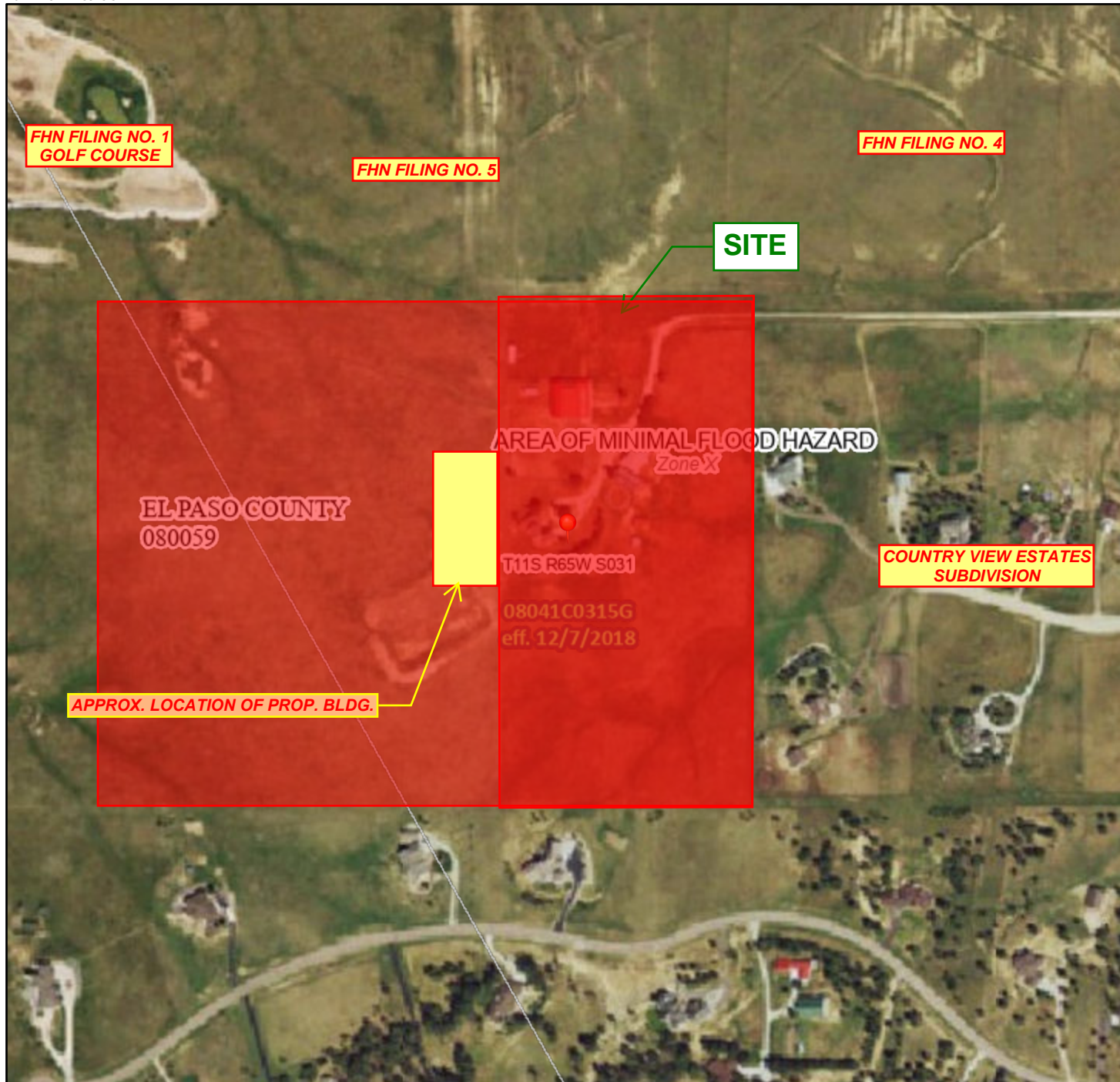

1:6,000

104°42'14"W 39°2'37"N

Basemap Imagery Source: USGS National Map 2023

Legend

SEE FIS REPORT FOR DETAILED LEGEND AND INDEX MAP FOR FIRM PANEL LAYOUT

SPECIAL FLOOD HAZARD AREAS		Without Base Flood Elevation (BFE) <i>Zone A, V, A99</i>
		With BFE or Depth <i>Zone AE, AO, AH, VE, AR</i>
		Regulatory Floodway
OTHER AREAS OF FLOOD HAZARD		0.2% Annual Chance Flood Hazard, Areas of 1% annual chance flood with average depth less than one foot or with drainage areas of less than one square mile <i>Zone X</i>
		Future Conditions 1% Annual Chance Flood Hazard <i>Zone X</i>
		Area with Reduced Flood Risk due to Levee. See Notes. <i>Zone X</i>
		Area with Flood Risk due to Levee <i>Zone D</i>
OTHER AREAS		NO SCREEN Area of Minimal Flood Hazard <i>Zone X</i>
		Effective LOMRs
GENERAL STRUCTURES		Area of Undetermined Flood Hazard <i>Zone D</i>
		Channel, Culvert, or Storm Sewer
		Levee, Dike, or Floodwall
OTHER FEATURES		20.2 Cross Sections with 1% Annual Chance Water Surface Elevation
		17.5 Coastal Transect
		Base Flood Elevation Line (BFE)
		Limit of Study
		Jurisdiction Boundary
		Coastal Transect Baseline
MAP PANELS		Profile Baseline
		Hydrographic Feature
		Digital Data Available
		No Digital Data Available
		Unmapped



The pin displayed on the map is an approximate point selected by the user and does not represent an authoritative property location.

This map complies with FEMA's standards for the use of digital flood maps if it is not void as described below. The basemap shown complies with FEMA's basemap accuracy standards

The flood hazard information is derived directly from the authoritative NFHL web services provided by FEMA. This map was exported on 1/23/2025 at 6:49 PM and does not reflect changes or amendments subsequent to this date and time. The NFHL and effective information may change or become superseded by new data over time.

This map image is void if the one or more of the following map elements do not appear: basemap imagery, flood zone labels, legend, scale bar, map creation date, community identifiers, FIRM panel number, and FIRM effective date. Map images for unmapped and unmodernized areas cannot be used for regulatory purposes.



APPENDIX B – GEC PLANS





APPENDIX C – CALCULATIONS



**TEMPORARY SEDIMENT BASIN
SEDIMENT BASIN STAGE-STORAGE CALCULATIONS**

Elevation	Area S.F.	Area Acre	Volume Cu. Ft.	Volume Acre-Ft	Cumm Vol Cu. Ft.	Cumm Vol Acre-Ft	Proration Enter Vol. in Cu-Ft*	Proration Enter Vol. in Acre-Ft*	Elev. Cu-Ft
7621.0	1729								
7622.0	2504		2,105		2,105	0.048			
7623.0	3381		2,932		5,036	0.116	8,663		7,623.94
7624.0	4358		3,859		8,895	0.204			
7625.0	5435		4,887		13,782	0.316	17,327		7,625.59
7626.0	6613		6,015		19,797	0.454			
7627.0									
7628.0									
7629.0									
7630.0									
7631.0									
7632.0									
7633.0									
7634.0									
7635.0									
7636.0									
7637.0									
7638.0									
7639.0									
7640.0									
7641.0									
7642.0									

COLUMN 1 CENTROID EL.

ORIFICE 1-1	7,623.94
ORIFICE 1-2	7,624.27
ORIFICE 1-3	7,624.60
ORIFICE 1-4	7,624.93
ORIFICE 1-5	7,625.26
ORIFICE 1-6	7,625.59

SED Basin riser pipe orifice calculations		
A_0 =	area per row of orifices spaced on 4" centers (in ²)	
V=	0.1989 design volume (acre feet) * <15 ac.	
T_D =	72 time to drain the prescribed volume (hrs) (Typically 72 hours for EURV)	
H=	1.649 depth of volume (ft)	
S=	0.0001 Trickle channel slope (ft/ft) [Use 0.0001 for flat slope]	
		S=0%
A_0 =	0.5928 in ²	0.5911 in ²
Dia	0.87 in	
	1.74 Dia=/2	
	3.47 Dia=/4	
	6.94 Dia=/8	USE 7/8"
	13.88 Dia=/16	
	27.76 Dia=/32	

SEDIMENT VOLUME CALCULATIONS			
Disturbed area-acres	4.669	Acres	
Undisturbed area-acres	1.034	Acres	
Total Area-acres	5.703	Acres	
Sediment volume	17,327	cu-ft	0.3978 Acres-ft
Volume below lowest hole	8,663	cu-ft	0.1989 Acres-ft
Volume above lowest hole	8,663	cu-ft	0.1989 Acres-ft
Total Volume	17,327	cu-ft	0.3978 Acres-ft

Note: Enter values in highlighted cells only.

<u>BMP FEATURE</u>	<u>TOTAL TRIBUTARY AREA (AC)</u>	<u>DISTURBED AREA (AC)</u>	<u>UNDISTURBED AREA (AC)</u>	<u>BOTTOM SIZE (FT)</u>	<u>SEDIMENT VOLUME (AC-FT)</u>	<u>BASIN VOLUME (AC-FT)</u>	<u>BOTTOM ELEVATION</u>	<u>CREST ELEVATION</u>	<u>CREST WxL (FT)</u>	<u>TOP OF POND ELEVATION</u>	<u>LOWEST ORIFICE ELEVATION</u>	<u>TOTAL AREA OF ORIFICES (SQ IN)</u>	<u># OF ORIFICE COLUMNS</u>	<u>DIA OF ORIFICES (IN)</u>	<u>RISER PIPE INVERT</u>	<u>DAYLIGHT ELEVATION</u>	<u>OUTLET PIPE LENGTH (FT)</u>	<u>OUTLET PIPE SLOPE</u>
TSB	5.7	4.7	1.0	70' x 25'	0.40	0.45	7,621.00	7,625.00	8' x 26'	7,626.00	7,623.94	0.59	1	7/8"	7,624.00	7,623.00	37	2.7%

*ORIFICES TO BE EVERY 4" FROM LOWEST ORIFICE ELEVATION TO THE TOP OF RISER PIPE, TOTAL NUMBER OF ORIFICES VARY.



APPENDIX D – EL PASO COUNTY CONSTRUCTION CONTROL MEASURES



Description

Concrete waste management involves designating and properly managing a specific area of the construction site as a concrete washout area. A concrete washout area can be created using one of several approaches designed to receive wash water from washing of tools and concrete mixer chutes, liquid concrete waste from dump trucks, mobile batch mixers, or pump trucks. Three basic approaches are available: excavation of a pit in the ground, use of an above ground storage area, or use of prefabricated haul-away concrete washout containers. Surface discharges of concrete washout water from construction sites are prohibited.



Photograph CWA-1. Example of concrete washout area. Note gravel tracking pad for access and sign.

Appropriate Uses

Concrete washout areas must be designated on all sites that will generate concrete wash water or liquid concrete waste from onsite concrete mixing or concrete delivery.

Because pH is a pollutant of concern for washout activities, when unlined pits are used for concrete washout, the soil must have adequate buffering capacity to result in protection of state groundwater standards; otherwise, a liner/containment must be used. The following management practices are recommended to prevent an impact from unlined pits to groundwater:

- The use of the washout site should be temporary (less than 1 year), and
- The washout site should be not be located in an area where shallow groundwater may be present, such as near natural drainages, springs, or wetlands.

Design and Installation

Concrete washout activities must be conducted in a manner that does not contribute pollutants to surface waters or stormwater runoff. Concrete washout areas may be lined or unlined excavated pits in the ground, commercially manufactured prefabricated washout containers, or aboveground holding areas constructed of berms, sandbags or straw bales with a plastic liner.

Although unlined washout areas may be used, lined pits may be required to protect groundwater under certain conditions.

Do not locate an unlined washout area within 400 feet of any natural drainage pathway or waterbody or within 1,000 feet of any wells or drinking water sources. Even for lined concrete washouts, it is advisable to locate the facility away from waterbodies and drainage paths. If site constraints make these

Concrete Washout Area	
Functions	
Erosion Control	No
Sediment Control	No
Site/Material Management	Yes

setbacks infeasible or if highly permeable soils exist in the area, then the pit must be installed with an impermeable liner (16 mil minimum thickness) or surface storage alternatives using prefabricated concrete washout devices or a lined aboveground storage area should be used.

Design details with notes are provided in Detail CWA-1 for pits and CWA-2 for aboveground storage areas. Pre-fabricated concrete washout container information can be obtained from vendors.

Maintenance and Removal

A key consideration for concrete washout areas is to ensure that adequate signage is in place identifying the location of the washout area. Part of inspecting and maintaining washout areas is ensuring that adequate signage is provided and in good repair and that the washout area is being used, as opposed to washout in non-designated areas of the site.

Remove concrete waste in the washout area, as needed to maintain BMP function (typically when filled to about two-thirds of its capacity). Collect concrete waste and deliver offsite to a designated disposal location.

Upon termination of use of the washout site, accumulated solid waste, including concrete waste and any contaminated soils, must be removed from the site to prevent on-site disposal of solid waste. If the wash water is allowed to evaporate and the concrete hardens, it may be recycled.



Photograph CWA-2. Prefabricated concrete washout. Photo courtesy of CDOT.



Photograph CWA-3. Earthen concrete washout. Photo courtesy of CDOT.

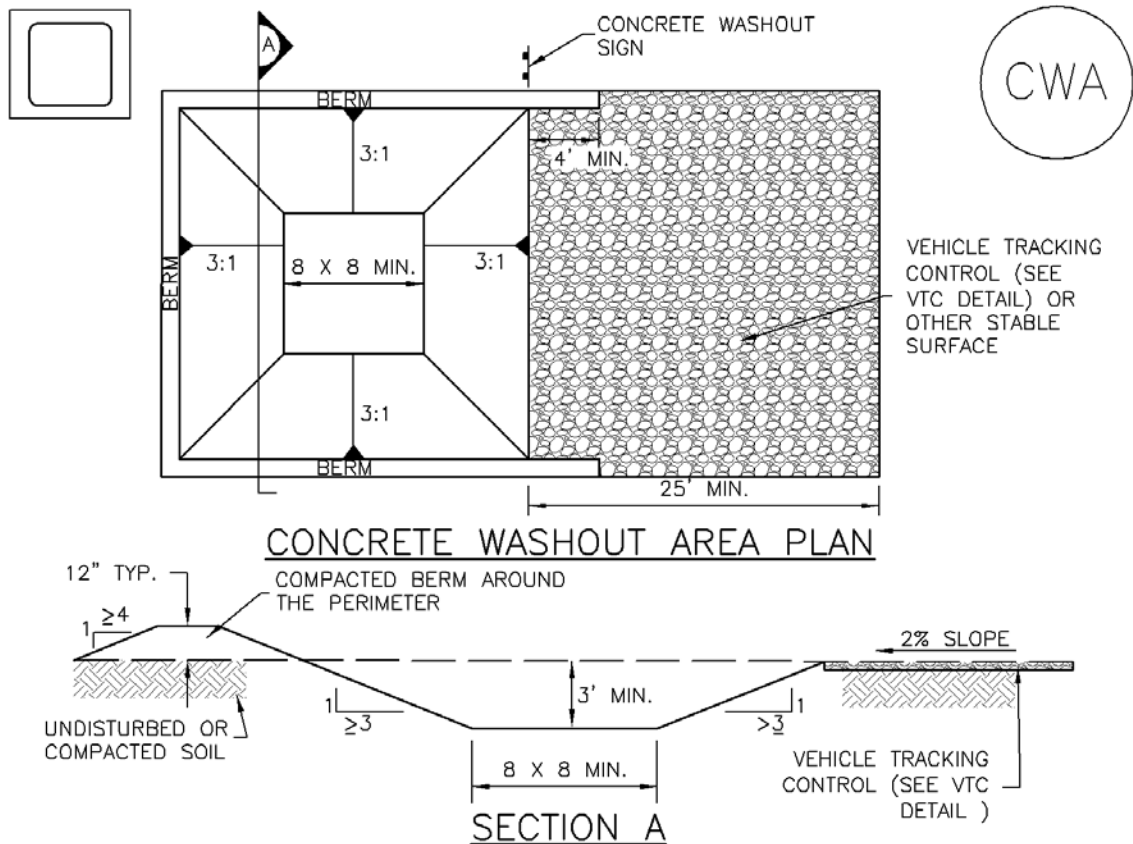

CWA-1. CONCRETE WASHOUT AREA

CWA INSTALLATION NOTES

1. SEE PLAN VIEW FOR:
-CWA INSTALLATION LOCATION.
2. DO NOT LOCATE AN UNLINED CWA WITHIN 400' OF ANY NATURAL DRAINAGE PATHWAY OR WATERBODY. DO NOT LOCATE WITHIN 1,000' OF ANY WELLS OR DRINKING WATER SOURCES. IF SITE CONSTRAINTS MAKE THIS INFEASIBLE, OR IF HIGHLY PERMEABLE SOILS EXIST ON SITE, THE CWA MUST BE INSTALLED WITH AN IMPERMEABLE LINER (16 MIL MIN. THICKNESS) OR SURFACE STORAGE ALTERNATIVES USING PREFABRICATED CONCRETE WASHOUT DEVICES OR A LINED ABOVE GROUND STORAGE ARE SHOULD BE USED.
3. THE CWA SHALL BE INSTALLED PRIOR TO CONCRETE PLACEMENT ON SITE.
4. CWA SHALL INCLUDE A FLAT SUBSURFACE PIT THAT IS AT LEAST 8' BY 8' SLOPES LEADING OUT OF THE SUBSURFACE PIT SHALL BE 3:1 OR FLATTER. THE PIT SHALL BE AT LEAST 3' DEEP.
5. BERM SURROUNDING SIDES AND BACK OF THE CWA SHALL HAVE MINIMUM HEIGHT OF 1'.
6. VEHICLE TRACKING PAD SHALL BE SLOPED 2% TOWARDS THE CWA.
7. SIGNS SHALL BE PLACED AT THE CONSTRUCTION ENTRANCE, AT THE CWA, AND ELSEWHERE AS NECESSARY TO CLEARLY INDICATE THE LOCATION OF THE CWA TO OPERATORS OF CONCRETE TRUCKS AND PUMP RIGS.
8. USE EXCAVATED MATERIAL FOR PERIMETER BERM CONSTRUCTION.

CWA MAINTENANCE NOTES

1. INSPECT BMPs EACH WORKDAY, AND MAINTAIN THEM IN EFFECTIVE OPERATING CONDITION. MAINTENANCE OF BMPs SHOULD BE PROACTIVE, NOT REACTIVE. INSPECT BMPs AS SOON AS POSSIBLE (AND ALWAYS WITHIN 24 HOURS) FOLLOWING A STORM THAT CAUSES SURFACE EROSION, AND PERFORM NECESSARY MAINTENANCE.

2. FREQUENT OBSERVATIONS AND MAINTENANCE ARE NECESSARY TO MAINTAIN BMPs IN EFFECTIVE OPERATING CONDITION. INSPECTIONS AND CORRECTIVE MEASURES SHOULD BE DOCUMENTED THOROUGHLY.

3. WHERE BMPs HAVE FAILED, REPAIR OR REPLACEMENT SHOULD BE INITIATED UPON DISCOVERY OF THE FAILURE.

4. THE CWA SHALL BE REPAIRED, CLEANED, OR ENLARGED AS NECESSARY TO MAINTAIN CAPACITY FOR CONCRETE WASTE. CONCRETE MATERIALS, ACCUMULATED IN PIT, SHALL BE REMOVED ONCE THE MATERIALS HAVE REACHED A DEPTH OF 2'.

5. CONCRETE WASHOUT WATER, WASTED PIECES OF CONCRETE AND ALL OTHER DEBRIS IN THE SUBSURFACE PIT SHALL BE TRANSPORTED FROM THE JOB SITE IN A WATER-TIGHT CONTAINER AND DISPOSED OF PROPERLY.

6. THE CWA SHALL REMAIN IN PLACE UNTIL ALL CONCRETE FOR THE PROJECT IS PLACED.

7. WHEN THE CWA IS REMOVED, COVER THE DISTURBED AREA WITH TOP SOIL, SEED AND MULCH OR OTHERWISE STABILIZED IN A MANNER APPROVED BY THE LOCAL JURISDICTION.

(DETAIL ADAPTED FROM DOUGLAS COUNTY, COLORADO AND THE CITY OF PARKER, COLORADO, NOT AVAILABLE IN AUTOCAD).

NOTE: MANY JURISDICTIONS HAVE BMP DETAILS THAT VARY FROM UDFCD STANDARD DETAILS. CONSULT WITH LOCAL JURISDICTIONS AS TO WHICH DETAIL SHOULD BE USED WHEN DIFFERENCES ARE NOTED.

Description

Earth dikes and drainage swales are temporary storm conveyance channels constructed either to divert runoff around slopes or to convey runoff to additional sediment control BMPs prior to discharge of runoff from a site. Drainage swales may be lined or unlined, but if an unlined swale is used, it must be well compacted and capable of resisting erosive velocities.

Appropriate Uses

Earth dikes and drainage swales are typically used to control the flow path of runoff at a construction site by diverting runoff around areas prone to erosion, such as steep slopes. Earth dikes and drainage swales may also be constructed as temporary conveyance features. This will direct runoff to additional sediment control treatment BMPs, such as sediment traps or basins.



Photograph ED/DS-1. Example of an earth dike used to divert flows at a construction site. Photo courtesy of CDOT.

Design and Installation

When earth dikes are used to divert water for slope protection, the earth dike typically consists of a horizontal ridge of soil placed perpendicular to the slope and angled slightly to provide drainage along the contour. The dike is used in conjunction with a swale or a small channel upslope of the berm to convey the diverted water. Temporary diversion dikes can be constructed by excavation of a V-shaped trench or ditch and placement of the fill on the downslope side of the cut. There are two types of placement for temporary slope diversion dikes:

- A dike located at the top of a slope to divert upland runoff away from the disturbed area and convey it in a temporary or permanent channel.
- A diversion dike located at the base or mid-slope of a disturbed area to intercept runoff and reduce the effective slope length.

Depending on the project, either an earth dike or drainage swale may be more appropriate. If there is a need for cut on the project, then an excavated drainage swale may be better suited. When the project is primarily fill, then a conveyance constructed using a berm may be the better option.

All dikes or swales receiving runoff from a disturbed area should direct stormwater to a sediment control BMP such as a sediment trap or basin.

Earth Dikes and Drainage Swales	
Functions	
Erosion Control	Yes
Sediment Control	Moderate
Site/Material Management	No

EC-10 Earth Dikes and Drainage Swales (ED/DS)

Unlined dikes or swales should only be used for intercepting sheet flow runoff and are not intended for diversion of concentrated flows.

Details with notes are provided for several design variations, including:

ED-1. Unlined Earth Dike formed by Berm

DS-1. Unlined Excavated Swale

DS-2. Unlined Swale Formed by Cut and Fill

DS-3. ECB-lined Swale

DS-4. Synthetic-lined Swale

DS-5. Riprap-lined Swale

The details also include guidance on permissible velocities for cohesive channels if unlined approaches will be used.

Maintenance and Removal

Inspect earth dikes for stability, compaction, and signs of erosion and repair. Inspect side slopes for erosion and damage to erosion control fabric. Stabilize slopes and repair fabric as necessary. If there is reoccurring extensive damage, consider installing rock check dams or lining the channel with riprap.

If drainage swales are not permanent, remove dikes and fill channels when the upstream area is stabilized. Stabilize the fill or disturbed area immediately following removal by revegetation or other permanent stabilization method approved by the local jurisdiction.

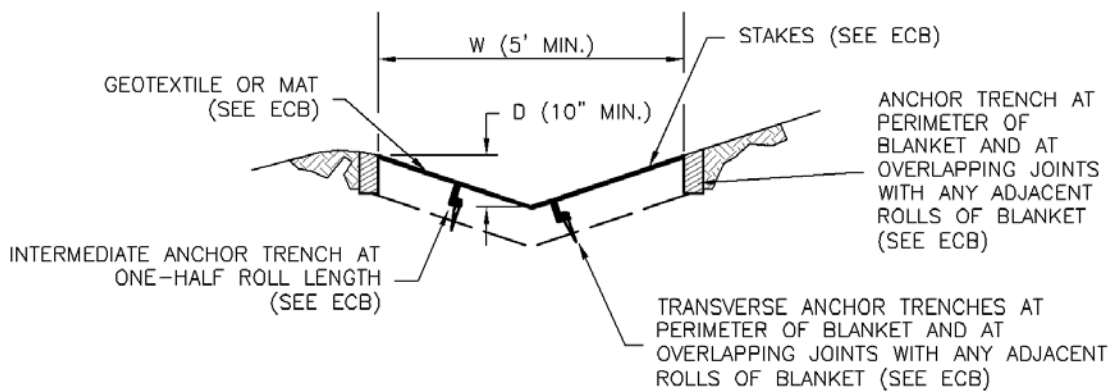
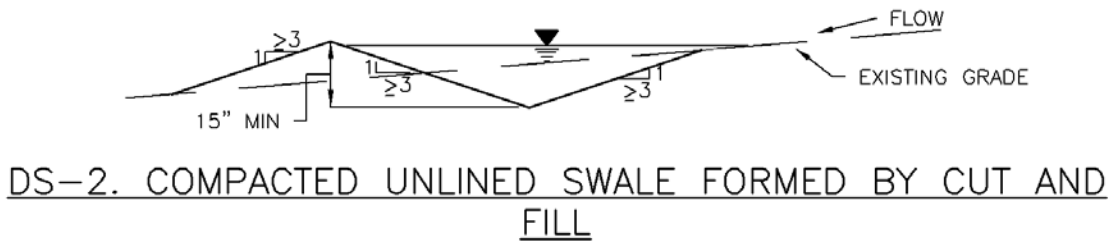
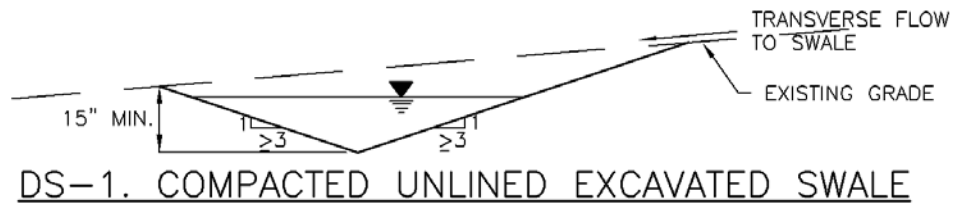
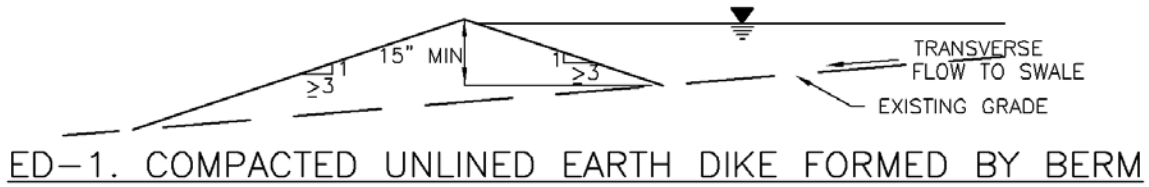
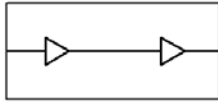

EC-10 Earth Dikes and Drainage Swales (ED/DS)

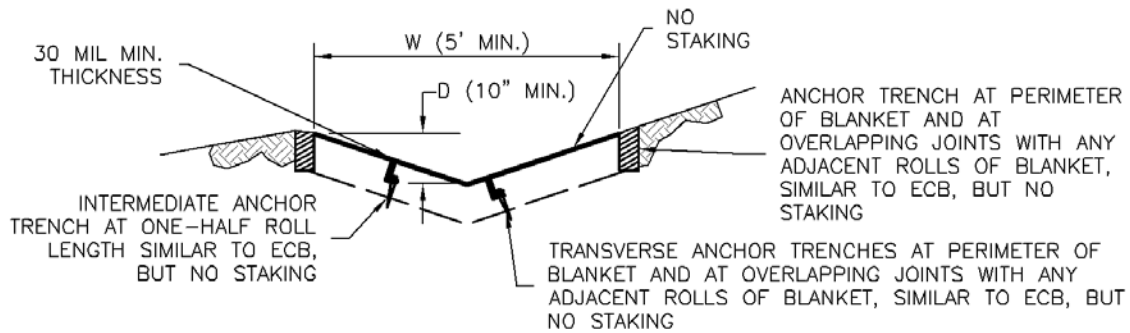

DS-4. SYNTHETIC LINED SWALE

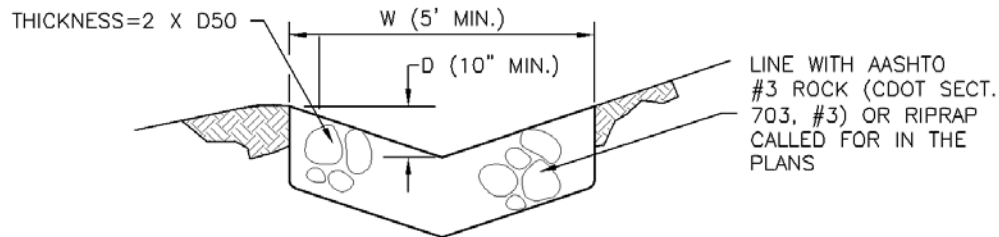

DS-5. RIPRAP LINED SWALE

EARTH DIKE AND DRAINAGE SWALE INSTALLATION NOTES

1. SEE SITE PLAN FOR:
 - LOCATION OF DIVERSION SWALE
 - TYPE OF SWALE (UNLINED, COMPACTED AND/OR LINED).
 - LENGTH OF EACH SWALE.
 - DEPTH, D, AND WIDTH, W DIMENSIONS.
 - FOR ECB/TRM LINED DITCH, SEE ECB DETAIL.
 - FOR RIPRAP LINED DITCH, SIZE OF RIPRAP, D50.
2. SEE DRAINAGE PLANS FOR DETAILS OF PERMANENT CONVEYANCE FACILITIES AND/OR DIVERSION SWALES EXCEEDING 2-YEAR FLOW RATE OR 10 CFS.
3. EARTH DIKES AND SWALES INDICATED ON SWMP PLAN SHALL BE INSTALLED PRIOR TO LAND-DISTURBING ACTIVITIES IN PROXIMITY.
4. EMBANKMENT IS TO BE COMPACTED TO 90% OF MAXIMUM DENSITY AND WITHIN 2% OF OPTIMUM MOISTURE CONTENT ACCORDING TO ASTM D698.
5. SWALES ARE TO DRAIN TO A SEDIMENT CONTROL BMP.
6. FOR LINED DITCHES, INSTALLATION OF ECB/TRM SHALL CONFORM TO THE REQUIREMENTS OF THE ECB DETAIL.
7. WHEN CONSTRUCTION TRAFFIC MUST CROSS A DIVERSION SWALE, INSTALL A TEMPORARY CULVERT WITH A MINIMUM DIAMETER OF 12 INCHES.

EARTH DIKE AND DRAINAGE SWALE MAINTENANCE NOTES

1. INSPECT BMPs EACH WORKDAY, AND MAINTAIN THEM IN EFFECTIVE OPERATING CONDITION. MAINTENANCE OF BMPs SHOULD BE PROACTIVE, NOT REACTIVE. INSPECT BMPs AS SOON AS POSSIBLE (AND ALWAYS WITHIN 24 HOURS) FOLLOWING A STORM THAT CAUSES SURFACE EROSION, AND PERFORM NECESSARY MAINTENANCE.
2. FREQUENT OBSERVATIONS AND MAINTENANCE ARE NECESSARY TO MAINTAIN BMPs IN EFFECTIVE OPERATING CONDITION. INSPECTIONS AND CORRECTIVE MEASURES SHOULD BE DOCUMENTED THOROUGHLY.
3. WHERE BMPs HAVE FAILED, REPAIR OR REPLACEMENT SHOULD BE INITIATED UPON DISCOVERY OF THE FAILURE.
4. SWALES SHALL REMAIN IN PLACE UNTIL THE END OF CONSTRUCTION; IF APPROVED BY LOCAL JURISDICTION, SWALES MAY BE LEFT IN PLACE.
5. WHEN A SWALE IS REMOVED, THE DISTURBED AREA SHALL BE COVERED WITH TOPSOIL, SEEDED AND MULCHED OR OTHERWISE STABILIZED IN A MANNER APPROVED BY LOCAL JURISDICTION.

(DETAIL ADAPTED FROM DOUGLAS COUNTY, COLORADO AND THE CITY OF COLORADO SPRINGS, COLORADO, NOT AVAILABLE IN AUTOCAD)

NOTE: MANY JURISDICTIONS HAVE BMP DETAILS THAT VARY FROM UDFCD STANDARD DETAILS. CONSULT WITH LOCAL JURISDICTIONS AS TO WHICH DETAIL SHOULD BE USED WHEN DIFFERENCES ARE NOTED.

Description

Implement construction site good housekeeping practices to prevent pollution associated with solid, liquid and hazardous construction-related materials and wastes. Stormwater Management Plans (SWMPs) should clearly specify BMPs including these good housekeeping practices:

- Provide for waste management.
- Establish proper building material staging areas.
- Designate paint and concrete washout areas.
- Establish proper equipment/vehicle fueling and maintenance practices.
- Control equipment/vehicle washing and allowable non-stormwater discharges.
- Develop a spill prevention and response plan.

Acknowledgement: This Fact Sheet is based directly on EPA guidance provided in *Developing Your Stormwater Pollution Prevent Plan (EPA 2007)*.

Appropriate Uses

Good housekeeping practices are necessary at all construction sites.

Design and Installation

The following principles and actions should be addressed in SWMPs:

- **Provide for Waste Management.** Implement management procedures and practices to prevent or reduce the exposure and transport of pollutants in stormwater from solid, liquid and sanitary wastes that will be generated at the site. Practices such as trash disposal, recycling, proper material handling, and cleanup measures can reduce the potential for stormwater runoff to pick up construction site wastes and discharge them to surface waters. Implement a comprehensive set of waste-management practices for hazardous or toxic materials, such as paints, solvents, petroleum products, pesticides, wood preservatives, acids, roofing tar, and other materials. Practices should include storage, handling, inventory, and cleanup procedures, in case of spills. Specific practices that should be considered include:

Solid or Construction Waste

- Designate trash and bulk waste-collection areas on-site.



Photographs GH-1 and GH-2. Proper materials storage and secondary containment for fuel tanks are important good housekeeping practices. Photos courtesy of CDOT and City of Aurora.

Good Housekeeping	
Functions	
Erosion Control	No
Sediment Control	No
Site/Material Management	Yes

- Recycle materials whenever possible (e.g., paper, wood, concrete, oil).
- Segregate and provide proper disposal options for hazardous material wastes.
- Clean up litter and debris from the construction site daily.
- Locate waste-collection areas away from streets, gutters, watercourses, and storm drains. Waste-collection areas (dumpsters, and such) are often best located near construction site entrances to minimize traffic on disturbed soils. Consider secondary containment around waste collection areas to minimize the likelihood of contaminated discharges.
- Empty waste containers before they are full and overflowing.

Sanitary and Septic Waste

- Provide convenient, well-maintained, and properly located toilet facilities on-site.
- Locate toilet facilities away from storm drain inlets and waterways to prevent accidental spills and contamination of stormwater.
- Maintain clean restroom facilities and empty portable toilets regularly.
- Where possible, provide secondary containment pans under portable toilets.
- Provide tie-downs or stake-downs for portable toilets.
- Educate employees, subcontractors, and suppliers on locations of facilities.
- Treat or dispose of sanitary and septic waste in accordance with state or local regulations. Do not discharge or bury wastewater at the construction site.
- Inspect facilities for leaks. If found, repair or replace immediately.
- Special care is necessary during maintenance (pump out) to ensure that waste and/or biocide are not spilled on the ground.

Hazardous Materials and Wastes

- Develop and implement employee and subcontractor education, as needed, on hazardous and toxic waste handling, storage, disposal, and cleanup.
- Designate hazardous waste-collection areas on-site.
- Place all hazardous and toxic material wastes in secondary containment.



Photograph GH-3. Locate portable toilet facilities on level surfaces away from waterways and storm drains. Photo courtesy of WWE.

- Hazardous waste containers should be inspected to ensure that all containers are labeled properly and that no leaks are present.
- **Establish Proper Building Material Handling and Staging Areas.** The SWMP should include comprehensive handling and management procedures for building materials, especially those that are hazardous or toxic. Paints, solvents, pesticides, fuels and oils, other hazardous materials or building materials that have the potential to contaminate stormwater should be stored indoors or under cover whenever possible or in areas with secondary containment. Secondary containment measures prevent a spill from spreading across the site and may include dikes, berms, curbing, or other containment methods. Secondary containment techniques should also ensure the protection of groundwater. Designate staging areas for activities such as fueling vehicles, mixing paints, plaster, mortar, and other potential pollutants. Designated staging areas enable easier monitoring of the use of materials and clean up of spills. Training employees and subcontractors is essential to the success of this pollution prevention principle. Consider the following specific materials handling and staging practices:
 - Train employees and subcontractors in proper handling and storage practices.
 - Clearly designate site areas for staging and storage with signs and on construction drawings. Staging areas should be located in areas central to the construction site. Segment the staging area into sub-areas designated for vehicles, equipment, or stockpiles. Construction entrances and exits should be clearly marked so that delivery vehicles enter/exit through stabilized areas with vehicle tracking controls (See Vehicle Tracking Control Fact Sheet).
 - Provide storage in accordance with Spill Protection, Control and Countermeasures (SPCC) requirements and plans and provide cover and impermeable perimeter control, as necessary, for hazardous materials and contaminated soils that must be stored on site.
 - Ensure that storage containers are regularly inspected for leaks, corrosion, support or foundation failure, or other signs of deterioration and tested for soundness.
 - Reuse and recycle construction materials when possible.
- **Designate Concrete Washout Areas.** Concrete contractors should be encouraged to use the washout facilities at their own plants or dispatch facilities when feasible; however, concrete washout commonly occurs on construction sites. If it is necessary to provide for concrete washout areas on-site, designate specific washout areas and design facilities to handle anticipated washout water. Washout areas should also be provided for paint and stucco operations. Because washout areas can be a source of pollutants from leaks or spills, care must be taken with regard to their placement and proper use. See the Concrete Washout Area Fact Sheet for detailed guidance.

Both self-constructed and prefabricated washout containers can fill up quickly when concrete, paint, and stucco work are occurring on large portions of the site. Be sure to check for evidence that contractors are using the washout areas and not dumping materials onto the ground or into drainage facilities. If the washout areas are not being used regularly, consider posting additional signage, relocating the facilities to more convenient locations, or providing training to workers and contractors.

When concrete, paint, or stucco is part of the construction process, consider these practices which will help prevent contamination of stormwater. Include the locations of these areas and the maintenance and inspection procedures in the SWMP.

- Do not washout concrete trucks or equipment into storm drains, streets, gutters, uncontained areas, or streams. Only use designated washout areas.
- Establish washout areas and advertise their locations with signs. Ensure that signage remains in good repair.
- Provide adequate containment for the amount of wash water that will be used.
- Inspect washout structures daily to detect leaks or tears and to identify when materials need to be removed.
- Dispose of materials properly. The preferred method is to allow the water to evaporate and to recycle the hardened concrete. Full service companies may provide dewatering services and should dispose of wastewater properly. Concrete wash water can be highly polluted. It should not be discharged to any surface water, storm sewer system, or allowed to infiltrate into the ground in the vicinity of waterbodies. Washwater should not be discharged to a sanitary sewer system without first receiving written permission from the system operator.
- **Establish Proper Equipment/Vehicle Fueling and Maintenance Practices.** Create a clearly designated on-site fueling and maintenance area that is clean and dry. The on-site fueling area should have a spill kit, and staff should know how to use it. If possible, conduct vehicle fueling and maintenance activities in a covered area. Consider the following practices to help prevent the discharge of pollutants to stormwater from equipment/vehicle fueling and maintenance. Include the locations of designated fueling and maintenance areas and inspection and maintenance procedures in the SWMP.
 - Train employees and subcontractors in proper fueling procedures (stay with vehicles during fueling, proper use of pumps, emergency shutoff valves, etc.).
 - Inspect on-site vehicles and equipment regularly for leaks, equipment damage, and other service problems.
 - Clearly designate vehicle/equipment service areas away from drainage facilities and watercourses to prevent stormwater run-on and runoff.
 - Use drip pans, drip cloths, or absorbent pads when replacing spent fluids.
 - Collect all spent fluids, store in appropriate labeled containers in the proper storage areas, and recycle fluids whenever possible.
- **Control Equipment/Vehicle Washing and Allowable Non-Stormwater Discharges.** Implement practices to prevent contamination of surface and groundwater from equipment and vehicle wash water. Representative practices include:
 - Educate employees and subcontractors on proper washing procedures.
 - Use off-site washing facilities, when available.
 - Clearly mark the washing areas and inform workers that all washing must occur in this area.
 - Contain wash water and treat it using BMPs. Infiltrate washwater when possible, but maintain separation from drainage paths and waterbodies.

- Use high-pressure water spray at vehicle washing facilities without detergents. Water alone can remove most dirt adequately.
- Do not conduct other activities, such as vehicle repairs, in the wash area.
- Include the location of the washing facilities and the inspection and maintenance procedures in the SWMP.
- **Develop a Spill Prevention and Response Plan.** Spill prevention and response procedures must be identified in the SWMP. Representative procedures include identifying ways to reduce the chance of spills, stop the source of spills, contain and clean up spills, dispose of materials contaminated by spills, and train personnel responsible for spill prevention and response. The plan should also specify material handling procedures and storage requirements and ensure that clear and concise spill cleanup procedures are provided and posted for areas in which spills may potentially occur. When developing a spill prevention plan, include the following:
 - Note the locations of chemical storage areas, storm drains, tributary drainage areas, surface waterbodies on or near the site, and measures to stop spills from leaving the site.
 - Provide proper handling and safety procedures for each type of waste. Keep Material Safety Data Sheets (MSDSs) for chemical used on site with the SWMP.
 - Establish an education program for employees and subcontractors on the potential hazards to humans and the environment from spills and leaks.
 - Specify how to notify appropriate authorities, such as police and fire departments, hospitals, or municipal sewage treatment facilities to request assistance. Emergency procedures and contact numbers should be provided in the SWMP and posted at storage locations.
 - Describe the procedures, equipment and materials for immediate cleanup of spills and proper disposal.
 - Identify personnel responsible for implementing the plan in the event of a spill. Update the spill prevention plan and clean up materials as changes occur to the types of chemicals stored and used at the facility.

Spill Prevention, Control, and Countermeasure (SPCC) Plan

Construction sites may be subject to 40 CFR Part 112 regulations that require the preparation and implementation of a SPCC Plan to prevent oil spills from aboveground and underground storage tanks. The facility is subject to this rule if it is a non-transportation-related facility that:

- Has a total storage capacity greater than 1,320 gallons or a completely buried storage capacity greater than 42,000 gallons.
- Could reasonably be expected to discharge oil in quantities that may be harmful to navigable waters of the United States and adjoining shorelines.

Furthermore, if the facility is subject to 40 CFR Part 112, the SWMP should reference the SPCC Plan. To find out more about SPCC Plans, see EPA's website on SPPC at www.epa.gov/oilspill/spcc.htm.

Reporting Oil Spills

In the event of an oil spill, contact the National Response Center toll free at 1-800-424- 8802 for assistance, or for more details, visit their website: www.nrc.uscg.mil.

Maintenance and Removal

Effective implementation of good housekeeping practices is dependent on clear designation of personnel responsible for supervising and implementing good housekeeping programs, such as site cleanup and disposal of trash and debris, hazardous material management and disposal, vehicle and equipment maintenance, and other practices. Emergency response "drills" may aid in emergency preparedness.

Checklists may be helpful in good housekeeping efforts.

Staging and storage areas require permanent stabilization when the areas are no longer being used for construction-related activities.

Construction-related materials, debris and waste must be removed from the construction site once construction is complete.

Design Details

See the following Fact Sheets for related Design Details:

MM-1 Concrete Washout Area

MM-2 Stockpile Management

SM-4 Vehicle Tracking Control

Design details are not necessary for other good housekeeping practices; however, be sure to designate where specific practices will occur on the appropriate construction drawings.

Description

Mulching consists of evenly applying straw, hay, shredded wood mulch, rock, bark or compost to disturbed soils and securing the mulch by crimping, tackifiers, netting or other measures. Mulching helps reduce erosion by protecting bare soil from rainfall impact, increasing infiltration, and reducing runoff. Although often applied in conjunction with temporary or permanent seeding, it can also be used for temporary stabilization of areas that cannot be reseeded due to seasonal constraints.

Mulch can be applied either using standard mechanical dry application methods or using hydromulching equipment that hydraulically applies a slurry of water, wood fiber mulch, and often a tackifier.



Photograph MU-1. An area that was recently seeded, mulched, and crimped.

Appropriate Uses

Use mulch in conjunction with seeding to help protect the seedbed and stabilize the soil. Mulch can also be used as a temporary cover on low to mild slopes to help temporarily stabilize disturbed areas where growing season constraints prevent effective reseeded. Disturbed areas should be properly mulched and tacked, or seeded, mulched and tacked promptly after final grade is reached (typically within no longer than 14 days) on portions of the site not otherwise permanently stabilized.

Standard dry mulching is encouraged in most jurisdictions; however, hydromulching may not be allowed in certain jurisdictions or may not be allowed near waterways.

Do not apply mulch during windy conditions.

Design and Installation

Prior to mulching, surface-roughen areas by rolling with a crimping or punching type roller or by track walking. Track walking should only be used where other methods are impractical because track walking with heavy equipment typically compacts the soil.

A variety of mulches can be used effectively at construction sites. Consider the following:

Mulch	
Functions	
Erosion Control	Yes
Sediment Control	Moderate
Site/Material Management	No

- Clean, weed-free and seed-free cereal grain straw should be applied evenly at a rate of 2 tons per acre and must be tacked or fastened by a method suitable for the condition of the site. Straw mulch must be anchored (and not merely placed) on the surface. This can be accomplished mechanically by crimping or with the aid of tackifiers or nets. Anchoring with a crimping implement is preferred, and is the recommended method for areas flatter than 3:1. Mechanical crimpers must be capable of tucking the long mulch fibers into the soil to a depth of 3 inches without cutting them. An agricultural disk, while not an ideal substitute, may work if the disk blades are dull or blunted and set vertically; however, the frame may have to be weighted to afford proper soil penetration.
- Grass hay may be used in place of straw; however, because hay is comprised of the entire plant including seed, mulching with hay may seed the site with non-native grass species which might in turn out-compete the native seed. Alternatively, native species of grass hay may be purchased, but can be difficult to find and are more expensive than straw. Purchasing and utilizing a certified weed-free straw is an easier and less costly mulching method. When using grass hay, follow the same guidelines as for straw (provided above).
- On small areas sheltered from the wind and heavy runoff, spraying a tackifier on the mulch is satisfactory for holding it in place. For steep slopes and special situations where greater control is needed, erosion control blankets anchored with stakes should be used instead of mulch.
- Hydraulic mulching consists of wood cellulose fibers mixed with water and a tackifying agent and should be applied at a rate of no less than 1,500 pounds per acre (1,425 lbs of fibers mixed with at least 75 lbs of tackifier) with a hydraulic mulcher. For steeper slopes, up to 2000 pounds per acre may be required for effective hydroseeding. Hydromulch typically requires up to 24 hours to dry; therefore, it should not be applied immediately prior to inclement weather. Application to roads, waterways and existing vegetation should be avoided.
- Erosion control mats, blankets, or nets are recommended to help stabilize steep slopes (generally 3:1 and steeper) and waterways. Depending on the product, these may be used alone or in conjunction with grass or straw mulch. Normally, use of these products will be restricted to relatively small areas. Biodegradable mats made of straw and jute, straw-coconut, coconut fiber, or excelsior can be used instead of mulch. (See the ECM/TRM BMP for more information.)
- Some tackifiers or binders may be used to anchor mulch. Check with the local jurisdiction for allowed tackifiers. Manufacturer's recommendations should be followed at all times. (See the Soil Binder BMP for more information on general types of tackifiers.)
- Rock can also be used as mulch. It provides protection of exposed soils to wind and water erosion and allows infiltration of precipitation. An aggregate base course can be spread on disturbed areas for temporary or permanent stabilization. The rock mulch layer should be thick enough to provide full coverage of exposed soil on the area it is applied.

Maintenance and Removal

After mulching, the bare ground surface should not be more than 10 percent exposed. Reapply mulch, as needed, to cover bare areas.

Description

Rolled Erosion Control Products (RECPs) include a variety of temporary or permanently installed manufactured products designed to control erosion and enhance vegetation establishment and survivability, particularly on slopes and in channels. For applications where natural vegetation alone will provide sufficient permanent erosion protection, temporary products such as netting, open weave textiles and a variety of erosion control blankets (ECBs) made of biodegradable natural materials (e.g., straw, coconut fiber) can be used. For applications where natural vegetation alone will not be sustainable under expected flow conditions, permanent rolled erosion control products such as turf reinforcement mats (TRMs) can be used. In particular, turf reinforcement mats are designed for discharges that exert velocities and shear stresses that exceed the typical limits of mature natural vegetation.



Photograph RECP-1. Erosion control blanket protecting the slope from erosion and providing favorable conditions for revegetation.

Appropriate Uses

RECPs can be used to control erosion in conjunction with revegetation efforts, providing seedbed protection from wind and water erosion. These products are often used on disturbed areas on steep slopes, in areas with highly erosive soils, or as part of drainageway stabilization. In order to select the appropriate RECP for site conditions, it is important to have a general understanding of the general types of these products, their expected longevity, and general characteristics.

The Erosion Control Technology Council (ECTC 2005) characterizes rolled erosion control products according to these categories:

- **Mulch control netting:** A planar woven natural fiber or extruded geosynthetic mesh used as a temporary degradable rolled erosion control product to anchor loose fiber mulches.
- **Open weave textile:** A temporary degradable rolled erosion control product composed of processed natural or polymer yarns woven into a matrix, used to provide erosion control and facilitate vegetation establishment.
- **Erosion control blanket (ECB):** A temporary degradable rolled erosion control product composed of processed natural or polymer fibers which are mechanically, structurally or chemically bound together to form a continuous matrix to provide erosion control and facilitate vegetation establishment. ECBs can be further differentiated into rapidly degrading single-net and double-net types or slowly degrading types.

Rolled Erosion Control Products	
Functions	
Erosion Control	Yes
Sediment Control	No
Site/Material Management	No

EC-6 Rolled Erosion Control Products (RECP)

- **Turf Reinforcement Mat (TRM):** A rolled erosion control product composed of non-degradable synthetic fibers, filaments, nets, wire mesh, and/or other elements, processed into a permanent, three-dimensional matrix of sufficient thickness. TRMs, which may be supplemented with degradable components, are designed to impart immediate erosion protection, enhance vegetation establishment and provide long-term functionality by permanently reinforcing vegetation during and after maturation. Note: TRMs are typically used in hydraulic applications, such as high flow ditches and channels, steep slopes, stream banks, and shorelines, where erosive forces may exceed the limits of natural, unreinforced vegetation or in areas where limited vegetation establishment is anticipated.

Tables RECP-1 and RECP-2 provide guidelines for selecting rolled erosion control products appropriate to site conditions and desired longevity. Table RECP-1 is for conditions where natural vegetation alone will provide permanent erosion control, whereas Table RECP-2 is for conditions where vegetation alone will not be adequately stable to provide long-term erosion protection due to flow or other conditions.

Table RECP-1. ECTC Standard Specification for Temporary Rolled Erosion Control Products
(Adapted from Erosion Control Technology Council 2005)

Product Description	Slope Applications*		Channel Applications*	Minimum Tensile Strength ¹	Expected Longevity
	Maximum Gradient	C Factor ^{2,5}			
Mulch Control Nets	5:1 (H:V)	≤0.10 @ 5:1	0.25 lbs/ft ² (12 Pa)	5 lbs/ft (0.073 kN/m)	Up to 12 months
Netless Rolled Erosion Control Blankets	4:1 (H:V)	≤0.10 @ 4:1	0.5 lbs/ft ² (24 Pa)	5 lbs/ft (0.073 kN/m)	
Single-net Erosion Control Blankets & Open Weave Textiles	3:1 (H:V)	≤0.15 @ 3:1	1.5 lbs/ft ² (72 Pa)	50 lbs/ft (0.73 kN/m)	
Double-net Erosion Control Blankets	2:1 (H:V)	≤0.20 @ 2:1	1.75 lbs/ft ² (84 Pa)	75 lbs/ft (1.09 kN/m)	
Mulch Control Nets	5:1 (H:V)	≤0.10 @ 5:1	0.25 lbs/ft ² (12 Pa)	25 lbs/ft (0.36 kN/m)	24 months
Erosion Control Blankets & Open Weave Textiles (slowly degrading)	1.5:1 (H:V)	≤0.25 @ 1.5:1	2.00 lbs/ft ² (96 Pa)	100 lbs/ft (1.45 kN/m)	24 months
Erosion Control Blankets & Open Weave Textiles	1:1 (H:V)	≤0.25 @ 1:1	2.25 lbs/ft ² (108 Pa)	125 lbs/ft (1.82 kN/m)	36 months

* C Factor and shear stress for mulch control nettings must be obtained with netting used in conjunction with pre-applied mulch material. (See Section 5.3 of Chapter 7 Construction BMPs for more information on the C Factor.)

¹ Minimum Average Roll Values, Machine direction using ECTC Mod. ASTM D 5035.

² C Factor calculated as ratio of soil loss from RECP protected slope (tested at specified or greater gradient, H:V) to ratio of soil loss from unprotected (control) plot in large-scale testing.

³ Required minimum shear stress RECP (unvegetated) can sustain without physical damage or excess erosion (> 12.7 mm (0.5 in) soil loss) during a 30-minute flow event in large-scale testing.

⁴ The permissible shear stress levels established for each performance category are based on historical experience with products characterized by Manning's roughness coefficients in the range of 0.01 - 0.05.

⁵ Acceptable large-scale test methods may include ASTM D 6459, or other independent testing deemed acceptable by the engineer.

⁶ Per the engineer's discretion. Recommended acceptable large-scale testing protocol may include ASTM D 6460, or other independent testing deemed acceptable by the engineer.

Table RECP-2. ECTC Standard Specification for Permanent¹ Rolled Erosion Control Products
(Adapted from: Erosion Control Technology Council 2005)

Product Type	Slope Applications	Channel Applications	
TRMs with a minimum thickness of 0.25 inches (6.35 mm) per ASTM D 6525 and UV stability of 80% per ASTM D 4355 (500 hours exposure).	Maximum Gradient	Maximum Shear Stress ^{4,5}	Minimum Tensile Strength ^{2,3}
	0.5:1 (H:V)	6.0 lbs/ft ² (288 Pa)	125 lbs/ft (1.82 kN/m)
	0.5:1 (H:V)	8.0 lbs/ft ² (384 Pa)	150 lbs/ft (2.19 kN/m)
	0.5:1 (H:V)	10.0 lbs/ft ² (480 Pa)	175 lbs/ft (2.55 kN/m)

¹ For TRMs containing degradable components, all property values must be obtained on the non-degradable portion of the matting alone.

² Minimum Average Roll Values, machine direction only for tensile strength determination using [ASTM D 6818](#) (Supersedes Mod. [ASTM D 5035](#) for RECPs)

³ Field conditions with high loading and/or high survivability requirements may warrant the use of a TRM with a tensile strength of 44 kN/m (3,000 lb/ft) or greater.

⁴ Required minimum shear stress TRM (fully vegetated) can sustain without physical damage or excess erosion (> 12.7 mm (0.5 in.) soil loss) during a 30-minute flow event in large scale testing.

⁵ Acceptable large-scale testing protocols may include [ASTM D 6460](#), or other independent testing deemed acceptable by the engineer.

Design and Installation

RECPs should be installed according to manufacturer’s specifications and guidelines. Regardless of the type of product used, it is important to ensure no gaps or voids exist under the material and that all corners of the material are secured using stakes and trenching. Continuous contact between the product and the soil is necessary to avoid failure. Never use metal stakes to secure temporary erosion control products. Often wooden stakes are used to anchor RECPs; however, wood stakes may present installation and maintenance challenges and generally take a long time to biodegrade. Some local jurisdictions have had favorable experiences using biodegradable stakes.

This BMP Fact Sheet provides design details for several commonly used ECB applications, including:

ECB-1 Pipe Outlet to Drainageway

ECB-2 Small Ditch or Drainageway

ECB-3 Outside of Drainageway

Staking patterns are also provided in the design details according to these factors:

- ECB type
- Slope or channel type

For other types of RECPs including TRMs, these design details are intended to serve as general guidelines for design and installation; however, engineers should adhere to manufacturer's installation recommendations.

Maintenance and Removal

Inspection of erosion control blankets and other RECPs includes:

- Check for general signs of erosion, including voids beneath the mat. If voids are apparent, fill the void with suitable soil and replace the erosion control blanket, following the appropriate staking pattern.
- Check for damaged or loose stakes and secure loose portions of the blanket.

Erosion control blankets and other RECPs that are biodegradable typically do not need to be removed after construction. If they must be removed, then an alternate soil stabilization method should be installed promptly following removal.

Turf reinforcement mats, although generally resistant to biodegradation, are typically left in place as a dense vegetated cover grows in through the mat matrix. The turf reinforcement mat provides long-term stability and helps the established vegetation resist erosive forces.

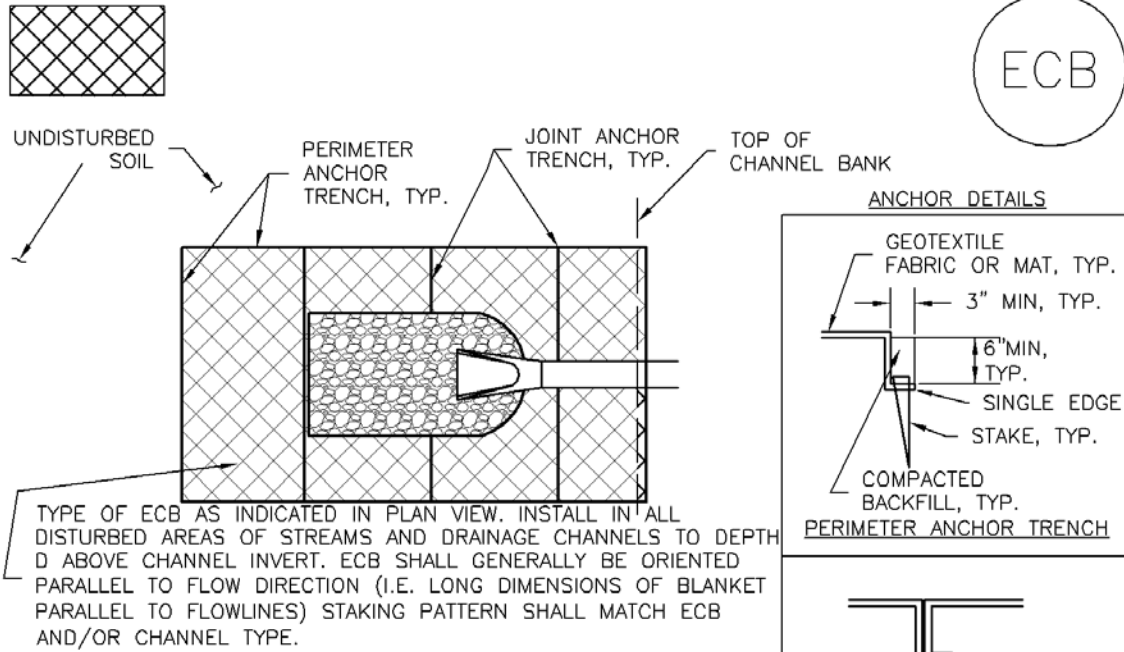

ECB-1. PIPE OUTLET TO DRAINAGEWAY

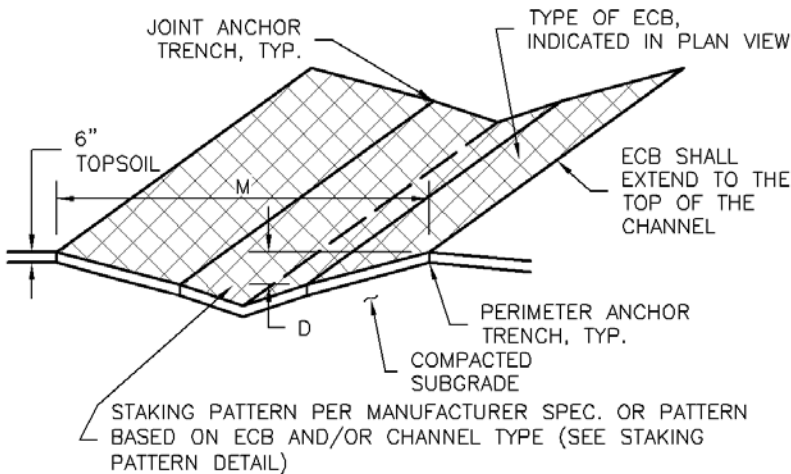

ECB-2. SMALL DITCH OR DRAINAGEWAY

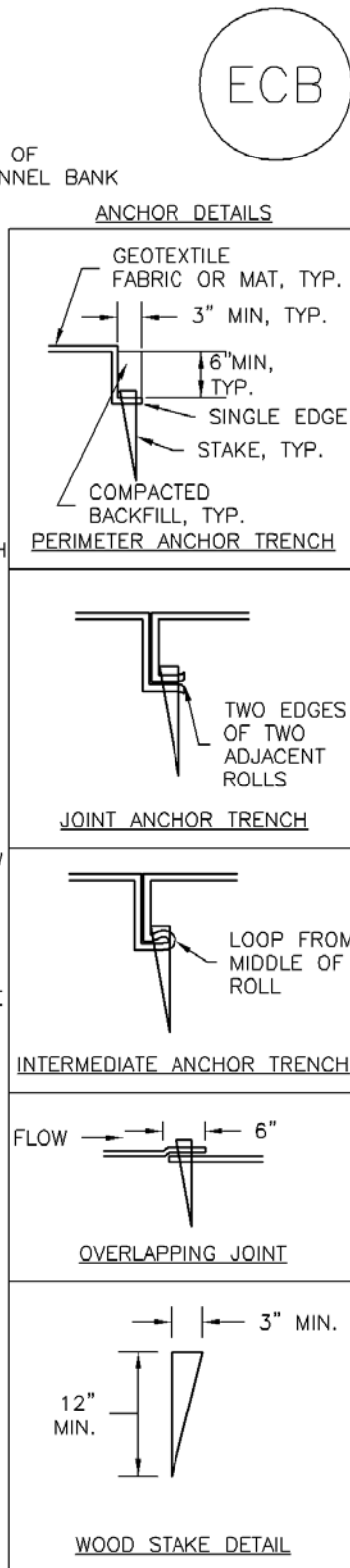

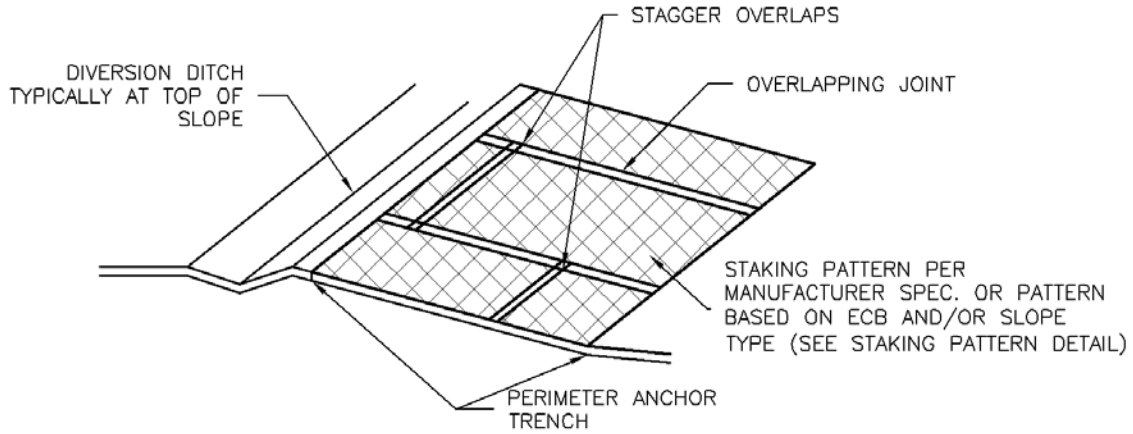

ECB-3. OUTSIDE OF DRAINAGEWAY

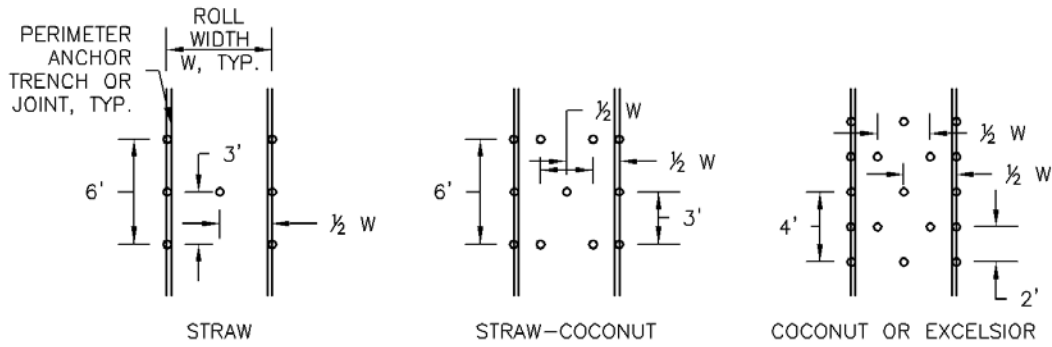

STAKING PATTERNS BY ECB TYPE

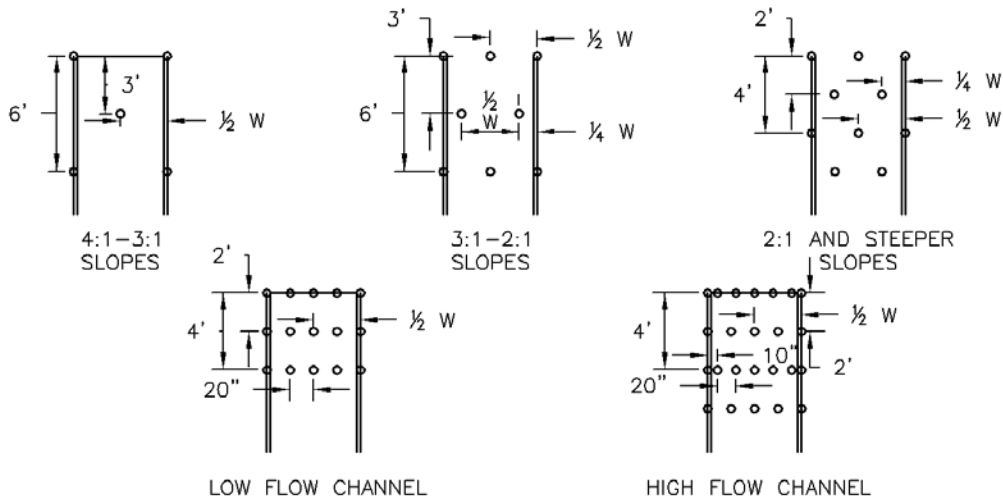

STAKING PATTERNS BY SLOPE OR CHANNEL TYPE

EROSION CONTROL BLANKET INSTALLATION NOTES

1. SEE PLAN VIEW FOR:
 - LOCATION OF ECB.
 - TYPE OF ECB (STRAW, STRAW-COCONUT, COCONUT, OR EXCELSIOR).
 - AREA, A, IN SQUARE YARDS OF EACH TYPE OF ECB.
2. 100% NATURAL AND BIODEGRADABLE MATERIALS ARE PREFERRED FOR RECPs, ALTHOUGH SOME JURISDICTIONS MAY ALLOW OTHER MATERIALS IN SOME APPLICATIONS.
3. IN AREAS WHERE ECBs ARE SHOWN ON THE PLANS, THE PERMITTEE SHALL PLACE TOPSOIL AND PERFORM FINAL GRADING, SURFACE PREPARATION, AND SEEDING AND MULCHING. SUBGRADE SHALL BE SMOOTH AND MOIST PRIOR TO ECB INSTALLATION AND THE ECB SHALL BE IN FULL CONTACT WITH SUBGRADE. NO GAPS OR VOIDS SHALL EXIST UNDER THE BLANKET.
4. PERIMETER ANCHOR TRENCH SHALL BE USED ALONG THE OUTSIDE PERIMETER OF ALL BLANKET AREAS.
5. JOINT ANCHOR TRENCH SHALL BE USED TO JOIN ROLLS OF ECBs TOGETHER (LONGITUDINALLY AND TRANSVERSELY) FOR ALL ECBs EXCEPT STRAW WHICH MAY USE AN OVERLAPPING JOINT.
6. INTERMEDIATE ANCHOR TRENCH SHALL BE USED AT SPACING OF ONE-HALF ROLL LENGTH FOR COCONUT AND EXCELSIOR ECBs.
7. OVERLAPPING JOINT DETAIL SHALL BE USED TO JOIN ROLLS OF ECBs TOGETHER FOR ECBs ON SLOPES.
8. MATERIAL SPECIFICATIONS OF ECBs SHALL CONFORM TO TABLE ECB-1.
9. ANY AREAS OF SEEDING AND MULCHING DISTURBED IN THE PROCESS OF INSTALLING ECBs SHALL BE RESEEDED AND MULCHED.
10. DETAILS ON DESIGN PLANS FOR MAJOR DRAINAGEWAY STABILIZATION WILL GOVERN IF DIFFERENT FROM THOSE SHOWN HERE.

TABLE ECB-1. ECB MATERIAL SPECIFICATIONS				
TYPE	COCONUT CONTENT	STRAW CONTENT	EXCELSIOR CONTENT	RECOMMENDED NETTING**
STRAW*	-	100%	-	DOUBLE/ NATURAL
STRAW-COCONUT	30% MIN	70% MAX	-	DOUBLE/ NATURAL
COCONUT	100%	-	-	DOUBLE/ NATURAL
EXCELSIOR	-	-	100%	DOUBLE/ NATURAL

*STRAW ECBs MAY ONLY BE USED OUTSIDE OF STREAMS AND DRAINAGE CHANNEL.
 **ALTERNATE NETTING MAY BE ACCEPTABLE IN SOME JURISDICTIONS

EROSION CONTROL BLANKET MAINTENANCE NOTES

1. INSPECT BMPs EACH WORKDAY, AND MAINTAIN THEM IN EFFECTIVE OPERATING CONDITION. MAINTENANCE OF BMPs SHOULD BE PROACTIVE, NOT REACTIVE. INSPECT BMPs AS SOON AS POSSIBLE (AND ALWAYS WITHIN 24 HOURS) FOLLOWING A STORM THAT CAUSES SURFACE EROSION, AND PERFORM NECESSARY MAINTENANCE.
2. FREQUENT OBSERVATIONS AND MAINTENANCE ARE NECESSARY TO MAINTAIN BMPs IN EFFECTIVE OPERATING CONDITION. INSPECTIONS AND CORRECTIVE MEASURES SHOULD BE DOCUMENTED THOROUGHLY.
3. WHERE BMPs HAVE FAILED, REPAIR OR REPLACEMENT SHOULD BE INITIATED UPON DISCOVERY OF THE FAILURE.
4. ECBs SHALL BE LEFT IN PLACE TO EVENTUALLY BIODEGRADE, UNLESS REQUESTED TO BE REMOVED BY THE LOCAL JURISDICTION.
5. ANY ECB PULLED OUT, TORN, OR OTHERWISE DAMAGED SHALL BE REPAIRED OR REINSTALLED. ANY SUBGRADE AREAS BELOW THE GEOTEXTILE THAT HAVE ERODED TO CREATED A VOID UNDER THE BLANKET, OR THAT REMAIN DEVOID OF GRASS SHALL BE REPAIRED, RESEDED AND MULCHED AND THE ECB REINSTALLED.

NOTE: MANY JURISDICTIONS HAVE BMP DETAILS THAT VARY FROM UDFCD STANDARD DETAILS. CONSULT WITH LOCAL JURISDICTIONS AS TO WHICH DETAIL SHOULD BE USED WHEN DIFFERENCES ARE NOTED.

(DETAILS ADAPTED FROM DOUGLAS COUNTY, COLORADO AND TOWN OF PARKER COLORADO, NOT AVAILABLE IN AUTOCAD)

Description

A sediment basin is a temporary pond built on a construction site to capture eroded or disturbed soil transported in storm runoff prior to discharge from the site. Sediment basins are designed to capture site runoff and slowly release it to allow time for settling of sediment prior to discharge. Sediment basins are often constructed in locations that will later be modified to serve as post-construction stormwater basins.



Photograph SB-1. Sediment basin at the toe of a slope. Photo courtesy of WWE.

Appropriate Uses

Most large construction sites (typically greater than 2 acres) will require one or more sediment basins for effective management of construction site runoff. On linear construction projects, sediment basins may be impractical; instead, sediment traps or other combinations of BMPs may be more appropriate.

Sediment basins should not be used as stand-alone sediment controls. Erosion and other sediment controls should also be implemented upstream.

When feasible, the sediment basin should be installed in the same location where a permanent post-construction detention pond will be located.

Design and Installation

The design procedure for a sediment basin includes these steps:

- **Basin Storage Volume:** Provide a storage volume of at least 3,600 cubic feet per acre of drainage area. To the extent practical, undisturbed and/or off-site areas should be diverted around sediment basins to prevent “clean” runoff from mixing with runoff from disturbed areas. For undisturbed areas (both on-site and off-site) that cannot be diverted around the sediment basin, provide a minimum of 500 ft³/acre of storage for undeveloped (but stable) off-site areas in addition to the 3,600 ft³/acre for disturbed areas. For stable, developed areas that cannot be diverted around the sediment basin, storage volume requirements are summarized in Table SB-1.
- **Basin Geometry:** Design basin with a minimum length-to-width ratio of 2:1 (L:W). If this cannot be achieved because of site space constraints, baffling may be required to extend the effective distance between the inflow point(s) and the outlet to minimize short-circuiting.
- **Dam Embankment:** It is recommended that embankment slopes be 4:1 (H:V) or flatter and no steeper than 3:1 (H:V) in any location.

Sediment Basins	
Functions	
Erosion Control	No
Sediment Control	Yes
Site/Material Management	No

- **Inflow Structure:** For concentrated flow entering the basin, provide energy dissipation at the point of inflow.

Table SB-1. Additional Volume Requirements for Undisturbed and Developed Tributary Areas Draining through Sediment Basins

Imperviousness (%)	Additional Storage Volume (ft ³) Per Acre of Tributary Area
Undeveloped	500
10	800
20	1230
30	1600
40	2030
50	2470
60	2980
70	3560
80	4360
90	5300
100	6460

- **Outlet Works:** The outlet pipe shall extend through the embankment at a minimum slope of 0.5 percent. Outlet works can be designed using one of the following approaches:
 - **Riser Pipe (Simplified Detail):** Detail SB-1 provides a simplified design for basins treating no more than 15 acres.
 - **Orifice Plate or Riser Pipe:** Follow the design criteria for Full Spectrum Detention outlets in the EDB Fact Sheet provided in Chapter 4 of this manual for sizing of outlet perforations with an emptying time of approximately 72 hours. In lieu of the trash rack, pack uniformly sized 1½ - to 2-inch gravel in front of the plate or surrounding the riser pipe. This gravel will need to be cleaned out frequently during the construction period as sediment accumulates within it. The gravel pack will need to be removed and disposed of following construction to reclaim the basin for use as a permanent detention facility. If the basin will be used as a permanent extended detention basin for the site, a trash rack will need to be installed once contributing drainage areas have been stabilized and the gravel pack and accumulated sediment have been removed.
 - **Floating Skimmer:** If a floating skimmer is used, install it using manufacturer’s recommendations. Illustration SB-1 provides an illustration of a Faircloth Skimmer Floating Outlet™, one of the more commonly used floating skimmer outlets. A skimmer should be designed to release the design volume in no less than 48 hours. The use of a floating skimmer outlet can increase the sediment capture efficiency of a basin significantly. A floating outlet continually decants cleanest water off the surface of the pond and releases cleaner water than would discharge from a perforated riser pipe or plate.

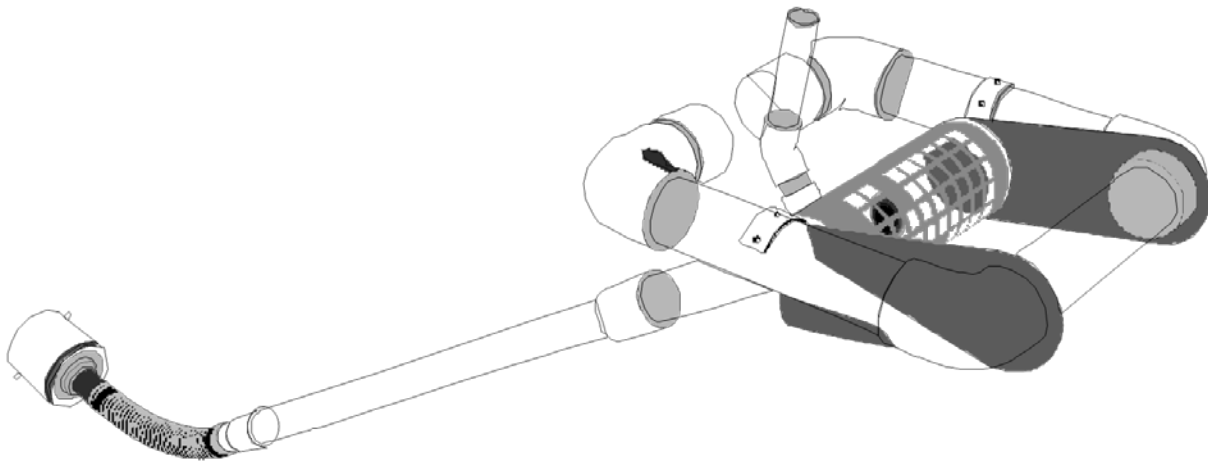

Illustration SB-1. Outlet structure for a temporary sediment basin - Faircloth Skimmer Floating Outlet. Illustration courtesy of J. W. Faircloth & Sons, Inc., FairclothSkimmer.com.

- **Outlet Protection and Spillway:** Consider all flow paths for runoff leaving the basin, including protection at the typical point of discharge as well as overtopping.
 - **Outlet Protection:** Outlet protection should be provided where the velocity of flow will exceed the maximum permissible velocity of the material of the waterway into which discharge occurs. This may require the use of a riprap apron at the outlet location and/or other measures to keep the waterway from eroding.
 - **Emergency Spillway:** Provide a stabilized emergency overflow spillway for rainstorms that exceed the capacity of the sediment basin volume and its outlet. Protect basin embankments from erosion and overtopping. If the sediment basin will be converted to a permanent detention basin, design and construct the emergency spillway(s) as required for the permanent facility. If the sediment basin will not become a permanent detention basin, it may be possible to substitute a heavy polyvinyl membrane or properly bedded rock cover to line the spillway and downstream embankment, depending on the height, slope, and width of the embankments.

Maintenance and Removal

Maintenance activities include the following:

- Dredge sediment from the basin, as needed to maintain BMP effectiveness, typically when the design storage volume is no more than one-third filled with sediment.
- Inspect the sediment basin embankments for stability and seepage.
- Inspect the inlet and outlet of the basin, repair damage, and remove debris. Remove, clean and replace the gravel around the outlet on a regular basis to remove the accumulated sediment within it and keep the outlet functioning.
- Be aware that removal of a sediment basin may require dewatering and associated permit requirements.
- Do not remove a sediment basin until the upstream area has been stabilized with vegetation.

Final disposition of the sediment basin depends on whether the basin will be converted to a permanent post-construction stormwater basin or whether the basin area will be returned to grade. For basins being converted to permanent detention basins, remove accumulated sediment and reconfigure the basin and outlet to meet the requirements of the final design for the detention facility. If the sediment basin is not to be used as a permanent detention facility, fill the excavated area with soil and stabilize with vegetation.

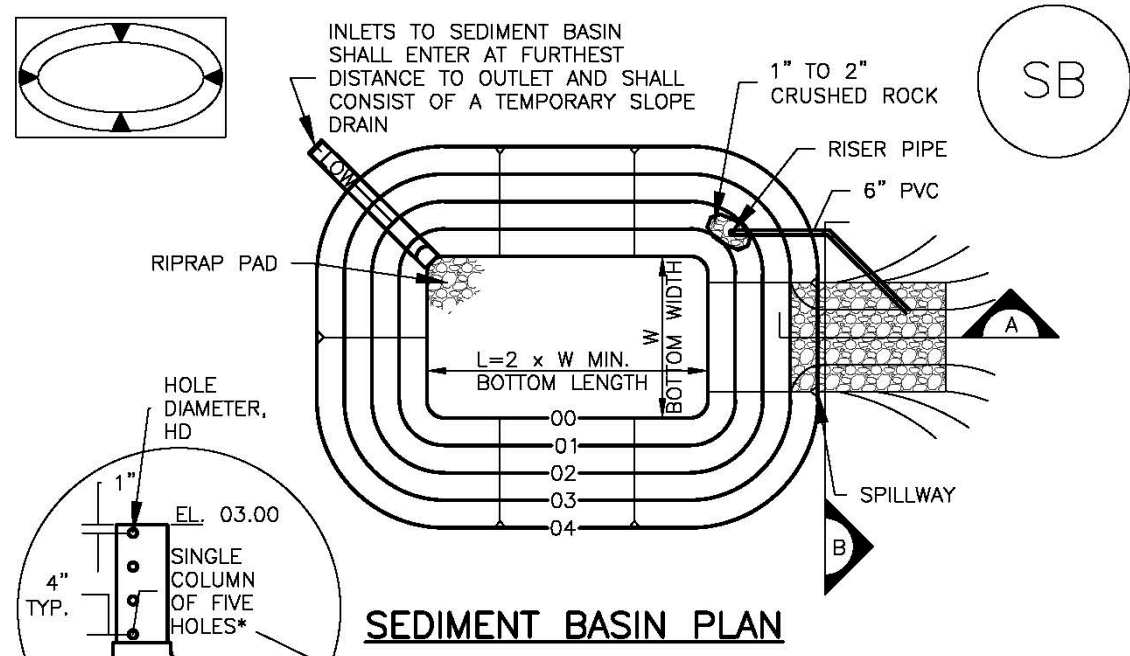

*EXCEPT WHERE THE HOLES EXCEED 1" DIAMETER, THEN UP TO TWO COLUMNS OF SAME SIZED HOLES MAY BE USED

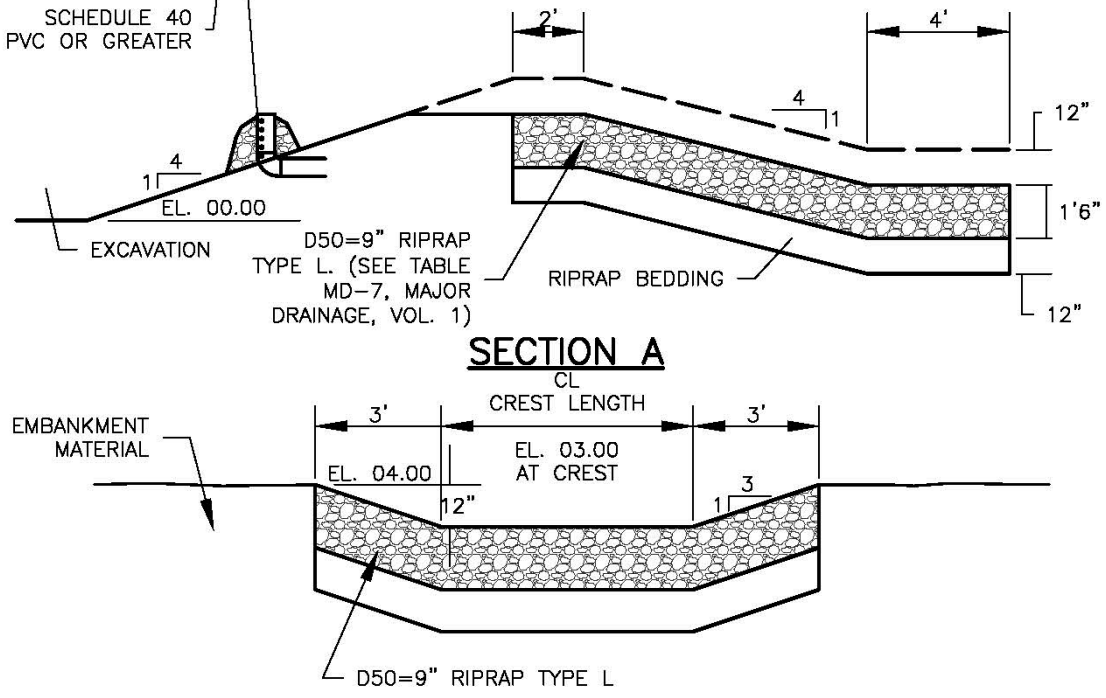

TABLE SB-1. SIZING INFORMATION FOR STANDARD SEDIMENT BASIN			
Upstream Drainage Area (rounded to nearest acre), (ac)	Basin Bottom Width (W), (ft)	Spillway Crest Length (CL), (ft)	Hole Diameter (HD), (in)
1	12 1/2	2	9/32
2	21	3	13/16
3	28	5	1/2
4	33 1/2	6	9/16
5	38 1/2	8	2 1/32
6	43	9	2 1/32
7	47 1/4	11	2 5/32
8	51	12	2 7/32
9	55	13	7/8
10	58 1/4	15	1 5/16
11	61	16	3 1/32
12	64	18	1
13	67 1/2	19	1 1/16
14	70 1/2	21	1 1/8
15	73 1/4	22	1 3/16

SEDIMENT BASIN INSTALLATION NOTES

1. SEE PLAN VIEW FOR:
 - LOCATION OF SEDIMENT BASIN.
 - TYPE OF BASIN (STANDARD BASIN OR NONSTANDARD BASIN).
 - FOR STANDARD BASIN, BOTTOM WIDTH W, CREST LENGTH CL, AND HOLE DIAMETER, HD.
 - FOR NONSTANDARD BASIN, SEE CONSTRUCTION DRAWINGS FOR DESIGN OF BASIN INCLUDING RISER HEIGHT H, NUMBER OF COLUMNS N, HOLE DIAMETER HD AND PIPE DIAMETER D.
2. FOR STANDARD BASIN, BOTTOM DIMENSION MAY BE MODIFIED AS LONG AS BOTTOM AREA IS NOT REDUCED.
3. SEDIMENT BASINS SHALL BE INSTALLED PRIOR TO ANY OTHER LAND-DISTURBING ACTIVITY THAT RELIES ON ON BASINS AS AS A STORMWATER CONTROL.
4. EMBANKMENT MATERIAL SHALL CONSIST OF SOIL FREE OF DEBRIS, ORGANIC MATERIAL, AND ROCKS OR CONCRETE GREATER THAN 3 INCHES AND SHALL HAVE A MINIMUM OF 15 PERCENT BY WEIGHT PASSING THE NO. 200 SIEVE.
5. EMBANKMENT MATERIAL SHALL BE COMPACTED TO AT LEAST 95 PERCENT OF MAXIMUM DENSITY IN ACCORDANCE WITH ASTM D698.
6. PIPE SCH 40 OR GREATER SHALL BE USED.
7. THE DETAILS SHOWN ON THESE SHEETS PERTAIN TO STANDARD SEDIMENT BASIN(S) FOR DRAINAGE AREAS LESS THAN 15 ACRES. SEE CONSTRUCTION DRAWINGS FOR EMBANKMENT, STORAGE VOLUME, SPILLWAY, OUTLET, AND OUTLET PROTECTION DETAILS FOR ANY SEDIMENT BASIN(S) THAT HAVE BEEN INDIVIDUALLY DESIGNED FOR DRAINAGE AREAS LARGER THAN 15 ACRES.

SEDIMENT BASIN MAINTENANCE NOTES

1. INSPECT BMPs EACH WORKDAY, AND MAINTAIN THEM IN EFFECTIVE OPERATING CONDITION. MAINTENANCE OF BMPs SHOULD BE PROACTIVE, NOT REACTIVE. INSPECT BMPs AS SOON AS POSSIBLE (AND ALWAYS WITHIN 24 HOURS) FOLLOWING A STORM THAT CAUSES SURFACE EROSION, AND PERFORM NECESSARY MAINTENANCE.
2. FREQUENT OBSERVATIONS AND MAINTENANCE ARE NECESSARY TO MAINTAIN BMPs IN EFFECTIVE OPERATING CONDITION. INSPECTIONS AND CORRECTIVE MEASURES SHOULD BE DOCUMENTED THOROUGHLY.
3. WHERE BMPs HAVE FAILED, REPAIR OR REPLACEMENT SHOULD BE INITIATED UPON DISCOVERY OF THE FAILURE.
4. SEDIMENT ACCUMULATED IN BASIN SHALL BE REMOVED AS NEEDED TO MAINTAIN BMP EFFECTIVENESS, TYPICALLY WHEN SEDIMENT DEPTH REACHES ONE FOOT (I.E., TWO FEET BELOW THE SPILLWAY CREST).
5. SEDIMENT BASINS ARE TO REMAIN IN PLACE UNTIL THE UPSTREAM DISTURBED AREA IS STABILIZED AND GRASS COVER IS ACCEPTED BY THE LOCAL JURISDICTION.
6. WHEN SEDIMENT BASINS ARE REMOVED, ALL DISTURBED AREAS SHALL BE COVERED WITH TOPSOIL, SEEDED AND MULCHED OR OTHERWISE STABILIZED AS APPROVED BY LOCAL JURISDICTION.

(DETAILS ADAPTED FROM DOUGLAS COUNTY, COLORADO)

NOTE: MANY JURISDICTIONS HAVE BMP DETAILS THAT VARY FROM UDFCD STANDARD DETAILS. CONSULT WITH LOCAL JURISDICTIONS AS TO WHICH DETAIL SHOULD BE USED WHEN DIFFERENCES ARE NOTED.

Description

Sediment traps are formed by excavating an area or by placing an earthen embankment across a low area or drainage swale. Sediment traps are designed to capture drainage from disturbed areas less than one acre and allow settling of sediment.



Photograph ST-1. Sediment traps are used to collect sediment-laden runoff from disturbed area. Photo courtesy of EPA Menu of BMPs.

Appropriate Uses

Sediment traps can be used in combination with other layers of erosion and sediment controls to trap sediment from small drainage areas (less than one acre) or areas with localized high sediment loading. For example, sediment traps are often provided in conjunction with vehicle tracking controls and wheel wash facilities.

Design and Installation

A sediment trap consists of a small excavated basin with an earthen berm and a riprap outlet. The berm of the sediment trap may be constructed from the excavated material and must be compacted to 95 percent of the maximum density in accordance with ASTM D698. An overflow outlet must be provided at an elevation at least 6 inches below the top of the berm. See Detail ST-1 for additional design and installation information.

Maintenance and Removal

Inspect the sediment trap embankments for stability and seepage.

Remove accumulated sediment as needed to maintain the effectiveness of the sediment trap, typically when the sediment depth is approximately one-half the height of the outflow embankment.

Inspect the outlet for debris and damage. Repair damage to the outlet, and remove all obstructions.

A sediment trap should not be removed until the upstream area is sufficiently stabilized. Upon removal of the trap, the disturbed area should be covered with topsoil and stabilized.

Sediment Trap	
Functions	
Erosion Control	No
Sediment Control	Yes
Site/Material Management	No

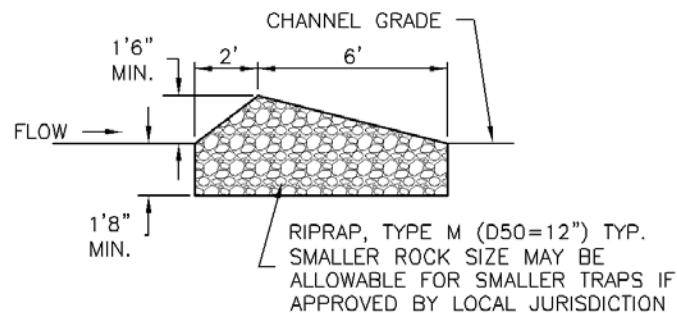
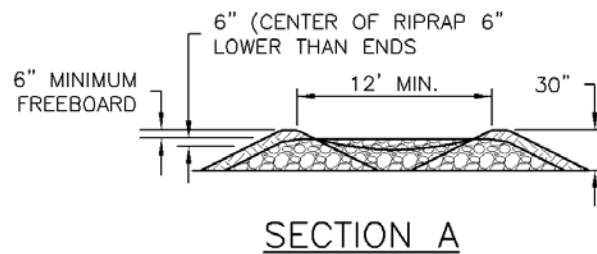
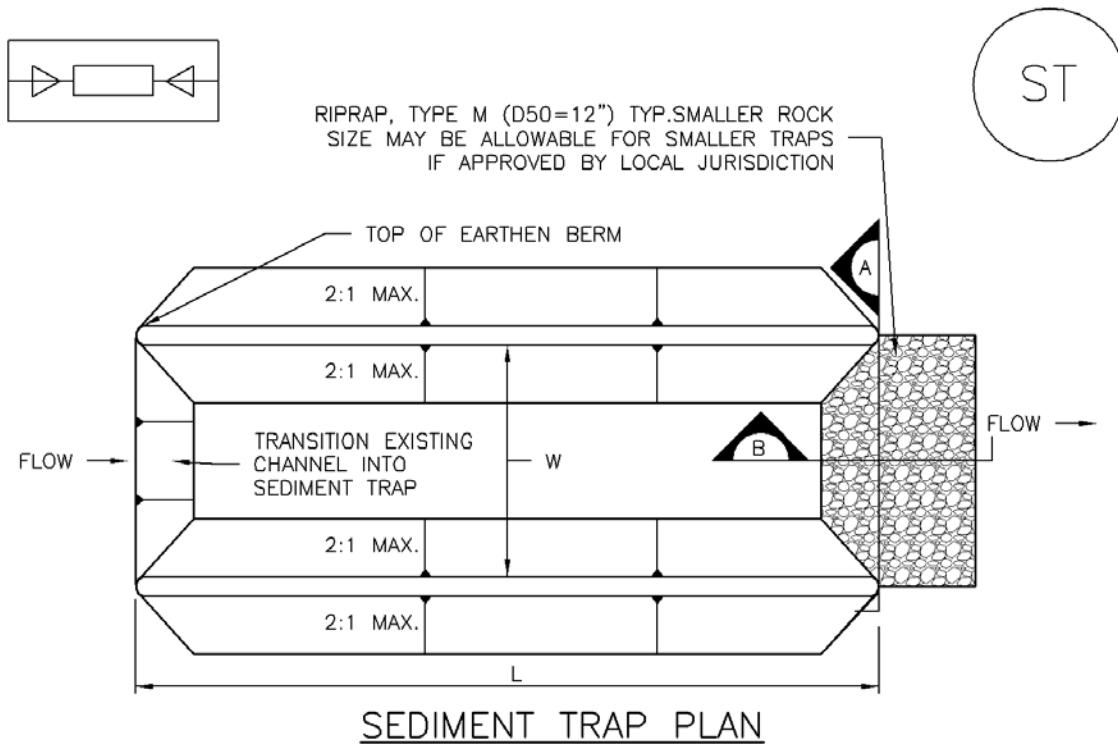

SECTION B
ST-1. SEDIMENT TRAP

SEDIMENT TRAP INSTALLATION NOTES

1. SEE PLAN VIEW FOR:
-LOCATION, LENGTH AND WIDTH OF SEDIMENT TRAP.
2. ONLY USE FOR DRAINAGE AREAS LESS THAN 1 ACRE.
3. SEDIMENT TRAPS SHALL BE INSTALLED PRIOR TO ANY UPGRADIENT LAND-DISTURBING ACTIVITIES.
4. SEDIMENT TRAP BERM SHALL BE CONSTRUCTED FROM MATERIAL FROM EXCAVATION. THE BERM SHALL BE COMPACTED TO 95% OF THE MAXIMUM DENSITY IN ACCORDANCE WITH ASTM D698.
5. SEDIMENT TRAP OUTLET TO BE CONSTRUCTED OF RIPRAP, TYPE M (D50=12") TYP. SMALLER ROCK SIZE MAY BE ALLOWABLE FOR SMALLER TRAPS IF APPROVED BY LOCAL JURISDICTION.
6. THE TOP OF THE EARTHEN BERM SHALL BE A MINIMUM OF 6" HIGHER THAN THE TOP OF THE RIPRAP OUTLET STRUCTURE.
7. THE ENDS OF THE RIPRAP OUTLET STRUCTURE SHALL BE A MINIMUM OF 6" HIGHER THAN THE CENTER OF THE OUTLET STRUCTURE.

SEDIMENT TRAP MAINTENANCE NOTES

1. INSPECT BMPs EACH WORKDAY, AND MAINTAIN THEM IN EFFECTIVE OPERATING CONDITION. MAINTENANCE OF BMPs SHOULD BE PROACTIVE, NOT REACTIVE. INSPECT BMPs AS SOON AS POSSIBLE (AND ALWAYS WITHIN 24 HOURS) FOLLOWING A STORM THAT CAUSES SURFACE EROSION, AND PERFORM NECESSARY MAINTENANCE.
2. FREQUENT OBSERVATIONS AND MAINTENANCE ARE NECESSARY TO MAINTAIN BMPs IN EFFECTIVE OPERATING CONDITION. INSPECTIONS AND CORRECTIVE MEASURES SHOULD BE DOCUMENTED THOROUGHLY.
3. WHERE BMPs HAVE FAILED, REPAIR OR REPLACEMENT SHOULD BE INITIATED UPON DISCOVERY OF THE FAILURE.
4. REMOVE SEDIMENT ACCUMULATED IN TRAP AS NEEDED TO MAINTAIN THE FUNCTIONALITY OF THE BMP, TYPICALLY WHEN THE SEDIMENT DEPTH REACHES $\frac{1}{2}$ THE HEIGHT OF THE RIPRAP OUTLET.
5. SEDIMENT TRAPS SHALL REMAIN IN PLACE UNTIL THE UPSTREAM DISTURBED AREA IS STABILIZED AND APPROVED BY THE LOCAL JURISDICTION.
6. WHEN SEDIMENT TRAPS ARE REMOVED, THE DISTURBED AREA SHALL BE COVERED WITH TOPSOIL, SEEDED AND MULCHED OR OTHERWISE STABILIZED IN A MANNER APPROVED BY THE LOCAL JURISDICTION.

(DETAILS ADAPTED FROM DOUGLAS COUNTY, COLORADO, NOT AVAILABLE IN AUTOCAD)

NOTE: MANY JURISDICTIONS HAVE BMP DETAILS THAT VARY FROM UDFCD STANDARD DETAILS. CONSULT WITH LOCAL JURISDICTIONS AS TO WHICH DETAIL SHOULD BE USED WHEN DIFFERENCES ARE NOTED.

Description

A silt fence is a woven geotextile fabric attached to wooden posts and trenched into the ground. It is designed as a sediment barrier to intercept sheet flow runoff from disturbed areas.

Appropriate Uses

A silt fence can be used where runoff is conveyed from a disturbed area as sheet flow. Silt fence is not designed to receive concentrated flow or to be used as a filter fabric. Typical uses include:

- Down slope of a disturbed area to accept sheet flow.
- Along the perimeter of a receiving water such as a stream, pond or wetland.
- At the perimeter of a construction site.



Photograph SF-1. Silt fence creates a sediment barrier, forcing sheet flow runoff to evaporate or infiltrate.

Design and Installation

Silt fence should be installed along the contour of slopes so that it intercepts sheet flow. The maximum recommended tributary drainage area per 100 lineal feet of silt fence, installed along the contour, is approximately 0.25 acres with a disturbed slope length of up to 150 feet and a tributary slope gradient no steeper than 3:1. Longer and steeper slopes require additional measures. This recommendation only applies to silt fence installed along the contour. Silt fence installed for other uses, such as perimeter control, should be installed in a way that will not produce concentrated flows. For example, a "J-hook" installation may be appropriate to force runoff to pond and evaporate or infiltrate in multiple areas rather than concentrate and cause erosive conditions parallel to the silt fence.

See Detail SF-1 for proper silt fence installation, which involves proper trenching, staking, securing the fabric to the stakes, and backfilling the silt fence. Properly installed silt fence should not be easily pulled out by hand and there should be no gaps between the ground and the fabric.

Silt fence must meet the minimum allowable strength requirements, depth of installation requirement, and other specifications in the design details. Improper installation of silt fence is a common reason for silt fence failure; however, when properly installed and used for the appropriate purposes, it can be highly effective.

Silt Fence	
Functions	
Erosion Control	No
Sediment Control	Yes
Site/Material Management	No

Maintenance and Removal

Inspection of silt fence includes observing the material for tears or holes and checking for slumping fence and undercut areas bypassing flows. Repair of silt fence typically involves replacing the damaged section with a new section. Sediment accumulated behind silt fence should be removed, as needed to maintain BMP effectiveness, typically before it reaches a depth of 6 inches.

Silt fence may be removed when the upstream area has reached final stabilization.



Photograph SF-2. When silt fence is not installed along the contour, a "J-hook" installation may be appropriate to ensure that the BMP does not create concentrated flow parallel to the silt fence. Photo courtesy of Tom Gore.

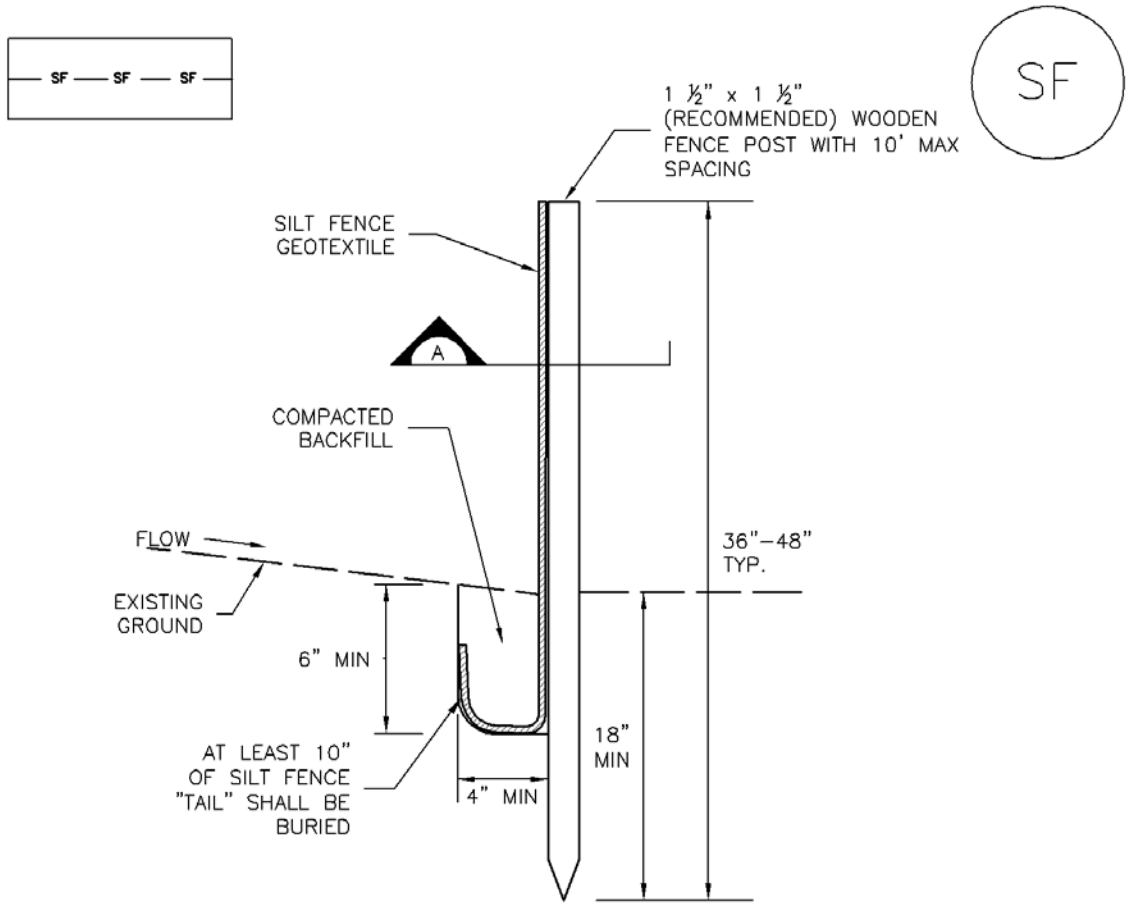

SILT FENCE

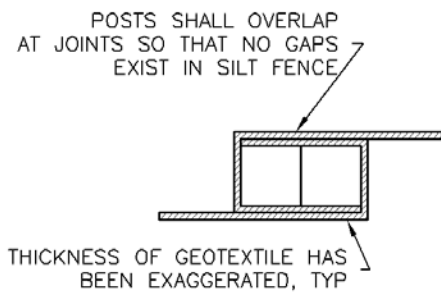
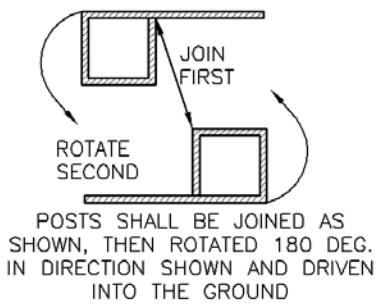

SECTION A

SF-1. SILT FENCE

SILT FENCE INSTALLATION NOTES

1. SILT FENCE MUST BE PLACED AWAY FROM THE TOE OF THE SLOPE TO ALLOW FOR WATER PONDING. SILT FENCE AT THE TOE OF A SLOPE SHOULD BE INSTALLED IN A FLAT LOCATION AT LEAST SEVERAL FEET (2-5 FT) FROM THE TOE OF THE SLOPE TO ALLOW ROOM FOR PONDING AND DEPOSITION.
2. A UNIFORM 6" X 4" ANCHOR TRENCH SHALL BE EXCAVATED USING TRENCHER OR SILT FENCE INSTALLATION DEVICE. NO ROAD GRADERS, BACKHOES, OR SIMILAR EQUIPMENT SHALL BE USED.
3. COMPACT ANCHOR TRENCH BY HAND WITH A "JUMPING JACK" OR BY WHEEL ROLLING. COMPACTION SHALL BE SUCH THAT SILT FENCE RESISTS BEING PULLED OUT OF ANCHOR TRENCH BY HAND.
4. SILT FENCE SHALL BE PULLED TIGHT AS IT IS ANCHORED TO THE STAKES. THERE SHOULD BE NO NOTICEABLE SAG BETWEEN STAKES AFTER IT HAS BEEN ANCHORED TO THE STAKES.
5. SILT FENCE FABRIC SHALL BE ANCHORED TO THE STAKES USING 1" HEAVY DUTY STAPLES OR NAILS WITH 1" HEADS. STAPLES AND NAILS SHOULD BE PLACED 3" ALONG THE FABRIC DOWN THE STAKE.
6. AT THE END OF A RUN OF SILT FENCE ALONG A CONTOUR, THE SILT FENCE SHOULD BE TURNED PERPENDICULAR TO THE CONTOUR TO CREATE A "J-HOOK." THE "J-HOOK" EXTENDING PERPENDICULAR TO THE CONTOUR SHOULD BE OF SUFFICIENT LENGTH TO KEEP RUNOFF FROM FLOWING AROUND THE END OF THE SILT FENCE (TYPICALLY 10' - 20').
7. SILT FENCE SHALL BE INSTALLED PRIOR TO ANY LAND DISTURBING ACTIVITIES.

SILT FENCE MAINTENANCE NOTES

1. INSPECT BMPs EACH WORKDAY, AND MAINTAIN THEM IN EFFECTIVE OPERATING CONDITION. MAINTENANCE OF BMPs SHOULD BE PROACTIVE, NOT REACTIVE. INSPECT BMPs AS SOON AS POSSIBLE (AND ALWAYS WITHIN 24 HOURS) FOLLOWING A STORM THAT CAUSES SURFACE EROSION, AND PERFORM NECESSARY MAINTENANCE.
2. FREQUENT OBSERVATIONS AND MAINTENANCE ARE NECESSARY TO MAINTAIN BMPs IN EFFECTIVE OPERATING CONDITION. INSPECTIONS AND CORRECTIVE MEASURES SHOULD BE DOCUMENTED THOROUGHLY.
3. WHERE BMPs HAVE FAILED, REPAIR OR REPLACEMENT SHOULD BE INITIATED UPON DISCOVERY OF THE FAILURE.
4. SEDIMENT ACCUMULATED UPSTREAM OF THE SILT FENCE SHALL BE REMOVED AS NEEDED TO MAINTAIN THE FUNCTIONALITY OF THE BMP, TYPICALLY WHEN DEPTH OF ACCUMULATED SEDIMENTS IS APPROXIMATELY 6".
5. REPAIR OR REPLACE SILT FENCE WHEN THERE ARE SIGNS OF WEAR, SUCH AS SAGGING, TEARING, OR COLLAPSE.
6. SILT FENCE IS TO REMAIN IN PLACE UNTIL THE UPSTREAM DISTURBED AREA IS STABILIZED AND APPROVED BY THE LOCAL JURISDICTION, OR IS REPLACED BY AN EQUIVALENT PERIMETER SEDIMENT CONTROL BMP.
7. WHEN SILT FENCE IS REMOVED, ALL DISTURBED AREAS SHALL BE COVERED WITH TOPSOIL, SEEDED AND MULCHED OR OTHERWISE STABILIZED AS APPROVED BY LOCAL JURISDICTION.

(DETAIL ADAPTED FROM TOWN OF PARKER, COLORADO AND CITY OF AURORA, NOT AVAILABLE IN AUTOCAD)

NOTE: MANY JURISDICTIONS HAVE BMP DETAILS THAT VARY FROM UDFCD STANDARD DETAILS. CONSULT WITH LOCAL JURISDICTIONS AS TO WHICH DETAIL SHOULD BE USED WHEN DIFFERENCES ARE NOTED.

Description

A stabilized staging area is a clearly designated area where construction equipment and vehicles, stockpiles, waste bins, and other construction-related materials are stored. The contractor office trailer may also be located in this area. Depending on the size of the construction site, more than one staging area may be necessary.



Photograph SSA-1. Example of a staging area with a gravel surface to prevent mud tracking and reduce runoff. Photo courtesy of Douglas County.

Appropriate Uses

Most construction sites will require a staging area, which should be clearly designated in SWMP drawings. The layout of the staging area may vary depending on the type of construction activity. Staging areas located in roadways due to space constraints require special measures to avoid materials being washed into storm inlets.

Design and Installation

Stabilized staging areas should be completed prior to other construction activities beginning on the site. Major components of a stabilized staging area include:

- Appropriate space to contain storage and provide for loading/unloading operations, as well as parking if necessary.
- A stabilized surface, either paved or covered, with 3-inch diameter aggregate or larger.
- Perimeter controls such as silt fence, sediment control logs, or other measures.
- Construction fencing to prevent unauthorized access to construction materials.
- Provisions for Good Housekeeping practices related to materials storage and disposal, as described in the Good Housekeeping BMP Fact Sheet.
- A stabilized construction entrance/exit, as described in the Vehicle Tracking Control BMP Fact Sheet, to accommodate traffic associated with material delivery and waste disposal vehicles.

Over-sizing the stabilized staging area may result in disturbance of existing vegetation in excess of that required for the project. This increases costs, as well as requirements for long-term stabilization following the construction period. When designing the stabilized staging area, minimize the area of disturbance to the extent practical.

Stabilized Staging Area	
Functions	
Erosion Control	Yes
Sediment Control	Moderate
Site/Material	Yes

Minimizing Long-Term Stabilization Requirements

- Utilize off-site parking and restrict vehicle access to the site.
- Use construction mats in lieu of rock when staging is provided in an area that will not be disturbed otherwise.
- Consider use of a bermed contained area for materials and equipment that do not require a stabilized surface.
- Consider phasing of staging areas to avoid disturbance in an area that will not be otherwise disturbed.

See Detail SSA-1 for a typical stabilized staging area and SSA-2 for a stabilized staging area when materials staging in roadways is required.

Maintenance and Removal

Maintenance of stabilized staging areas includes maintaining a stable surface cover of gravel, repairing perimeter controls, and following good housekeeping practices.

When construction is complete, debris, unused stockpiles and materials should be recycled or properly disposed. In some cases, this will require disposal of contaminated soil from equipment leaks in an appropriate landfill. Staging areas should then be permanently stabilized with vegetation or other surface cover planned for the development.

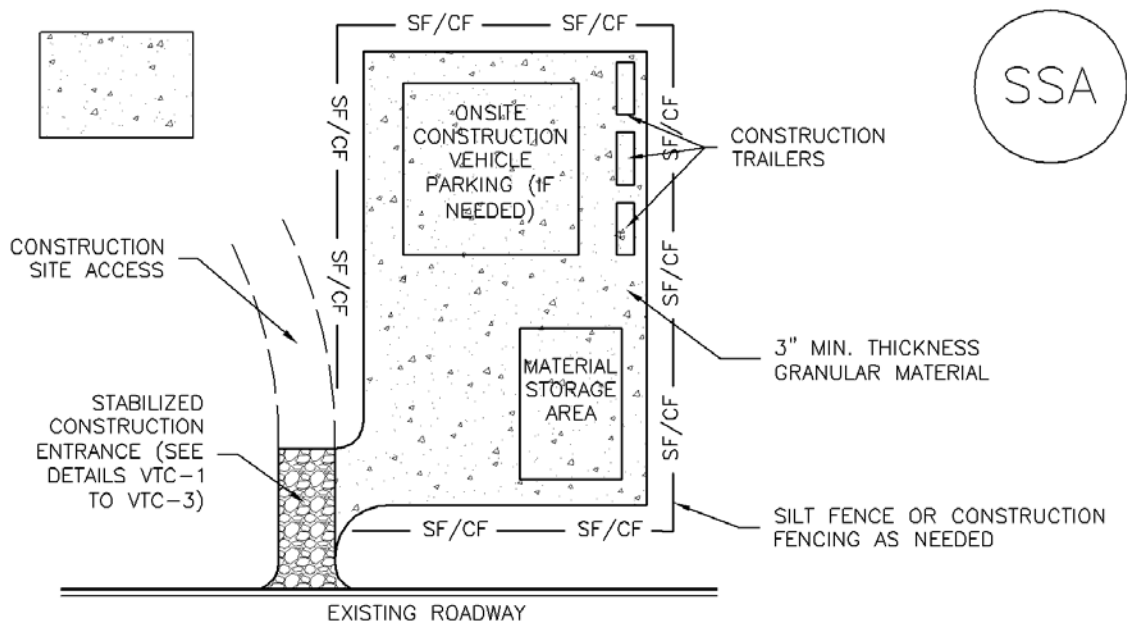

SSA-1. STABILIZED STAGING AREA

STABILIZED STAGING AREA INSTALLATION NOTES

1. SEE PLAN VIEW FOR
 - LOCATION OF STAGING AREA(S).
 - CONTRACTOR MAY ADJUST LOCATION AND SIZE OF STAGING AREA WITH APPROVAL FROM THE LOCAL JURISDICTION.
2. STABILIZED STAGING AREA SHOULD BE APPROPRIATE FOR THE NEEDS OF THE SITE. OVERSIZING RESULTS IN A LARGER AREA TO STABILIZE FOLLOWING CONSTRUCTION.
3. STAGING AREA SHALL BE STABILIZED PRIOR TO OTHER OPERATIONS ON THE SITE.
4. THE STABILIZED STAGING AREA SHALL CONSIST OF A MINIMUM 3" THICK GRANULAR MATERIAL.
5. UNLESS OTHERWISE SPECIFIED BY LOCAL JURISDICTION, ROCK SHALL CONSIST OF DOT SECT. #703, AASHTO #3 COARSE AGGREGATE OR 6" (MINUS) ROCK.
6. ADDITIONAL PERIMETER BMPs MAY BE REQUIRED INCLUDING BUT NOT LIMITED TO SILT FENCE AND CONSTRUCTION FENCING.

STABILIZED STAGING AREA MAINTENANCE NOTES

1. INSPECT BMPs EACH WORKDAY, AND MAINTAIN THEM IN EFFECTIVE OPERATING CONDITION. MAINTENANCE OF BMPs SHOULD BE PROACTIVE, NOT REACTIVE. INSPECT BMPs AS SOON AS POSSIBLE (AND ALWAYS WITHIN 24 HOURS) FOLLOWING A STORM THAT CAUSES SURFACE EROSION, AND PERFORM NECESSARY MAINTENANCE.
2. FREQUENT OBSERVATIONS AND MAINTENANCE ARE NECESSARY TO MAINTAIN BMPs IN EFFECTIVE OPERATING CONDITION. INSPECTIONS AND CORRECTIVE MEASURES SHOULD BE DOCUMENTED THOROUGHLY.
3. WHERE BMPs HAVE FAILED, REPAIR OR REPLACEMENT SHOULD BE INITIATED UPON DISCOVERY OF THE FAILURE.
4. ROCK SHALL BE REAPPLIED OR REGRADED AS NECESSARY IF RUTTING OCCURS OR UNDERLYING SUBGRADE BECOMES EXPOSED.

STABILIZED STAGING AREA MAINTENANCE NOTES

5. STABILIZED STAGING AREA SHALL BE ENLARGED IF NECESSARY TO CONTAIN PARKING, STORAGE, AND UNLOADING/LOADING OPERATIONS.

6. THE STABILIZED STAGING AREA SHALL BE REMOVED AT THE END OF CONSTRUCTION. THE GRANULAR MATERIAL SHALL BE REMOVED OR, IF APPROVED BY THE LOCAL JURISDICTION, USED ON SITE, AND THE AREA COVERED WITH TOPSOIL, SEEDED AND MULCHED OR OTHERWISE STABILIZED IN A MANNER APPROVED BY LOCAL JURISDICTION.

NOTE: MANY MUNICIPALITIES PROHIBIT THE USE OF RECYCLED CONCRETE AS GRANULAR MATERIAL FOR STABILIZED STAGING AREAS DUE TO DIFFICULTIES WITH RE-ESTABLISHMENT OF VEGETATION IN AREAS WHERE RECYCLED CONCRETE WAS PLACED.

NOTE: MANY JURISDICTIONS HAVE BMP DETAILS THAT VARY FROM UDFCD STANDARD DETAILS. CONSULT WITH LOCAL JURISDICTIONS AS TO WHICH DETAIL SHOULD BE USED WHEN DIFFERENCES ARE NOTED.

(DETAILS ADAPTED FROM DOUGLAS COUNTY, COLORADO, NOT AVAILABLE IN AUTOCAD)

Description

Stockpile management includes measures to minimize erosion and sediment transport from soil stockpiles.

Appropriate Uses

Stockpile management should be used when soils or other erodible materials are stored at the construction site. Special attention should be given to stockpiles in close proximity to natural or manmade storm systems.



Photograph SP-1. A topsoil stockpile that has been partially revegetated and is protected by silt fence perimeter control.

Design and Installation

Locate stockpiles away from all drainage system components including storm sewer inlets. Where practical, choose stockpile locations that that will remain undisturbed for the longest period of time as the phases of construction progress. Place sediment control BMPs around the perimeter of the stockpile, such as sediment control logs, rock socks, silt fence, straw bales and sand bags. See Detail SP-1 for guidance on proper establishment of perimeter controls around a stockpile. For stockpiles in active use, provide a stabilized designated access point on the upgradient side of the stockpile.

Stabilize the stockpile surface with surface roughening, temporary seeding and mulching, erosion control blankets, or soil binders. Soils stockpiled for an extended period (typically for more than 60 days) should be seeded and mulched with a temporary grass cover once the stockpile is placed (typically within 14 days). Use of mulch only or a soil binder is acceptable if the stockpile will be in place for a more limited time period (typically 30-60 days). Timeframes for stabilization of stockpiles noted in this fact sheet are "typical" guidelines. Check permit requirements for specific federal, state, and/or local requirements that may be more prescriptive.

Stockpiles should not be placed in streets or paved areas unless no other practical alternative exists. See the Stabilized Staging Area Fact Sheet for guidance when staging in roadways is unavoidable due to space or right-of-way constraints. For paved areas, rock socks must be used for perimeter control and all inlets with the potential to receive sediment from the stockpile (even from vehicle tracking) must be protected.

Maintenance and Removal

Inspect perimeter controls and inlet protection in accordance with their respective BMP Fact Sheets. Where seeding, mulch and/or soil binders are used, reseeding or reapplication of soil binder may be necessary.

When temporary removal of a perimeter BMP is necessary to access a stockpile, ensure BMPs are reinstalled in accordance with their respective design detail section.

Stockpile Management	
Functions	
Erosion Control	Yes
Sediment Control	Yes
Site/Material Management	Yes

When the stockpile is no longer needed, properly dispose of excess materials and revegetate or otherwise stabilize the ground surface where the stockpile was located.

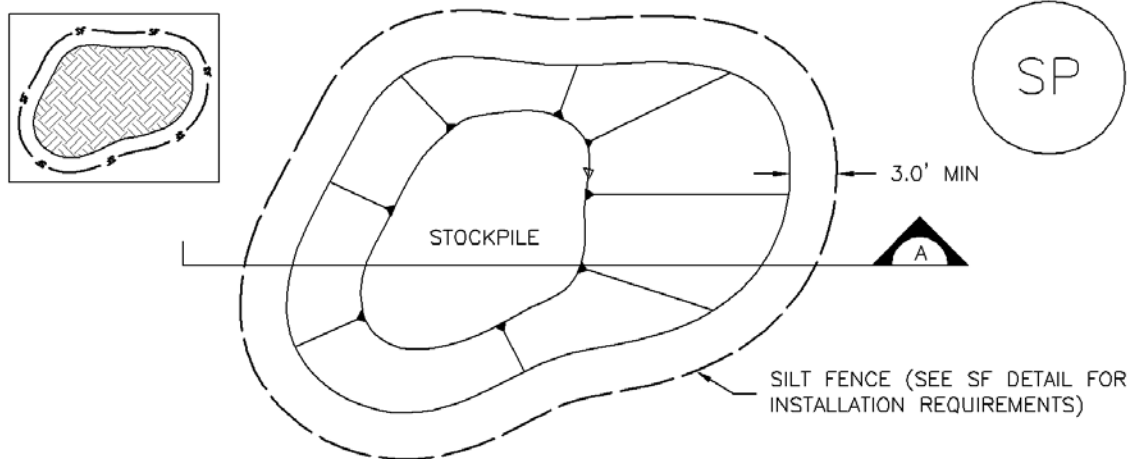

STOCKPILE PROTECTION PLAN

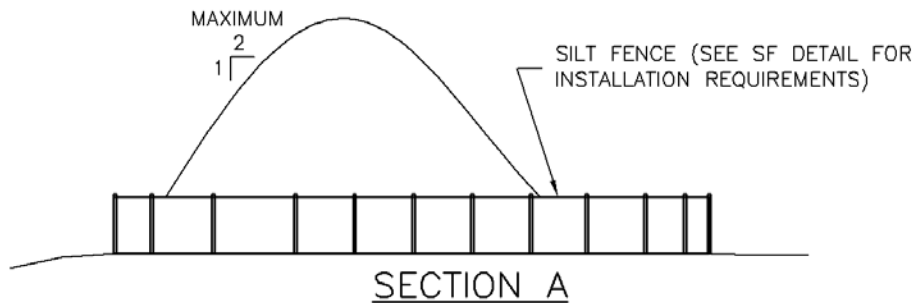

SP-1. STOCKPILE PROTECTION

STOCKPILE PROTECTION INSTALLATION NOTES

1. SEE PLAN VIEW FOR:
 - LOCATION OF STOCKPILES.
 - TYPE OF STOCKPILE PROTECTION.
2. INSTALL PERIMETER CONTROLS IN ACCORDANCE WITH THEIR RESPECTIVE DESIGN DETAILS. SILT FENCE IS SHOWN IN THE STOCKPILE PROTECTION DETAILS; HOWEVER, OTHER TYPES OF PERIMETER CONTROLS INCLUDING SEDIMENT CONTROL LOGS OR ROCK SOCKS MAY BE SUITABLE IN SOME CIRCUMSTANCES. CONSIDERATIONS FOR DETERMINING THE APPROPRIATE TYPE OF PERIMETER CONTROL FOR A STOCKPILE INCLUDE WHETHER THE STOCKPILE IS LOCATED ON A PERVIOUS OR IMPERVIOUS SURFACE, THE RELATIVE HEIGHTS OF THE PERIMETER CONTROL AND STOCKPILE, THE ABILITY OF THE PERIMETER CONTROL TO CONTAIN THE STOCKPILE WITHOUT FAILING IN THE EVENT THAT MATERIAL FROM THE STOCKPILE SHIFTS OR SLUMPS AGAINST THE PERIMETER, AND OTHER FACTORS.
3. STABILIZE THE STOCKPILE SURFACE WITH SURFACE ROUGHENING, TEMPORARY SEEDING AND MULCHING, EROSION CONTROL BLANKETS, OR SOIL BINDERS. SOILS STOCKPILED FOR AN EXTENDED PERIOD (TYPICALLY FOR MORE THAN 60 DAYS) SHOULD BE SEEDING AND MULCHED WITH A TEMPORARY GRASS COVER ONCE THE STOCKPILE IS PLACED (TYPICALLY WITHIN 14 DAYS). USE OF MULCH ONLY OR A SOIL BINDER IS ACCEPTABLE IF THE STOCKPILE WILL BE IN PLACE FOR A MORE LIMITED TIME PERIOD (TYPICALLY 30-60 DAYS).
4. FOR TEMPORARY STOCKPILES ON THE INTERIOR PORTION OF A CONSTRUCTION SITE, WHERE OTHER DOWNGRADIENT CONTROLS, INCLUDING PERIMETER CONTROL, ARE IN PLACE, STOCKPILE PERIMETER CONTROLS MAY NOT BE REQUIRED.

STOCKPILE PROTECTION MAINTENANCE NOTES

1. INSPECT BMPs EACH WORKDAY, AND MAINTAIN THEM IN EFFECTIVE OPERATING CONDITION. MAINTENANCE OF BMPs SHOULD BE PROACTIVE, NOT REACTIVE. INSPECT BMPs AS SOON AS POSSIBLE (AND ALWAYS WITHIN 24 HOURS) FOLLOWING A STORM THAT CAUSES SURFACE EROSION, AND PERFORM NECESSARY MAINTENANCE.

2. FREQUENT OBSERVATIONS AND MAINTENANCE ARE NECESSARY TO MAINTAIN BMPs IN EFFECTIVE OPERATING CONDITION. INSPECTIONS AND CORRECTIVE MEASURES SHOULD BE DOCUMENTED THOROUGHLY.

3. WHERE BMPs HAVE FAILED, REPAIR OR REPLACEMENT SHOULD BE INITIATED UPON DISCOVERY OF THE FAILURE.

STOCKPILE PROTECTION MAINTENANCE NOTES

4. IF PERIMETER PROTECTION MUST BE MOVED TO ACCESS SOIL STOCKPILE, REPLACE PERIMETER CONTROLS BY THE END OF THE WORKDAY.

5. STOCKPILE PERIMETER CONTROLS CAN BE REMOVED ONCE ALL THE MATERIAL FROM THE STOCKPILE HAS BEEN USED.

(DETAILS ADAPTED FROM PARKER, COLORADO, NOT AVAILABLE IN AUTOCAD)

NOTE: MANY JURISDICTIONS HAVE BMP DETAILS THAT VARY FROM UDFCD STANDARD DETAILS. CONSULT WITH LOCAL JURISDICTIONS AS TO WHICH DETAIL SHOULD BE USED WHEN DIFFERENCES ARE NOTED.

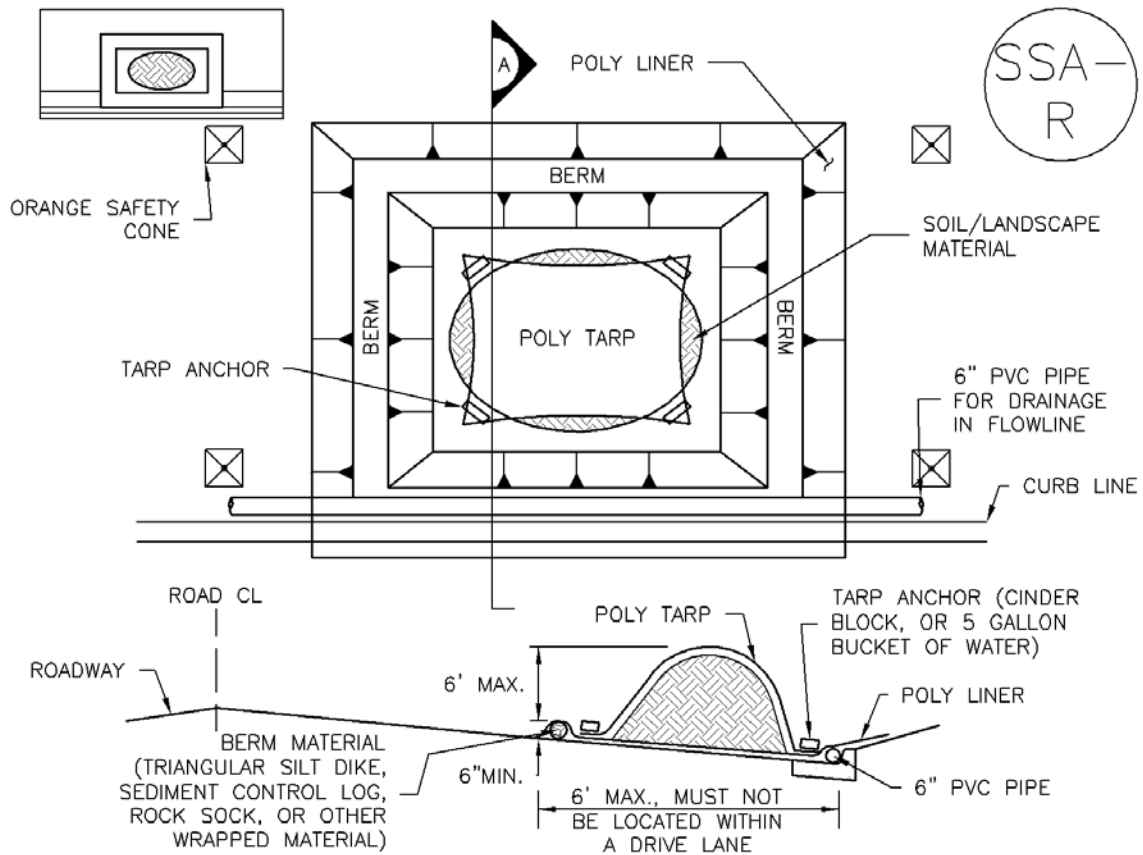

SP-2. MATERIALS STAGING IN ROADWAY

MATERIALS STAGING IN ROADWAYS INSTALLATION NOTES

1. SEE PLAN VIEW FOR
 - LOCATION OF MATERIAL STAGING AREA(S).
 - CONTRACTOR MAY ADJUST LOCATION AND SIZE OF STAGING AREA WITH APPROVAL FROM THE LOCAL JURISDICTION.
2. FEATURE MUST BE INSTALLED PRIOR TO EXCAVATION, EARTHWORK OR DELIVERY OF MATERIALS.
3. MATERIALS MUST BE STATIONED ON THE POLY LINER. ANY INCIDENTAL MATERIALS DEPOSITED ON PAVED SECTION OR ALONG CURB LINE MUST BE CLEANED UP PROMPTLY.
4. POLY LINER AND TARP COVER SHOULD BE OF SIGNIFICANT THICKNESS TO PREVENT DAMAGE OR LOSS OF INTEGRITY.
5. SAND BAGS MAY BE SUBSTITUTED TO ANCHOR THE COVER TARP OR PROVIDE BERMING UNDER THE BASE LINER.
6. FEATURE IS NOT INTENDED FOR USE WITH WET MATERIAL THAT WILL BE DRAINING AND/OR SPREADING OUT ON THE POLY LINER OR FOR DEMOLITION MATERIALS.
7. THIS FEATURE CAN BE USED FOR:
 - UTILITY REPAIRS.
 - WHEN OTHER STAGING LOCATIONS AND OPTIONS ARE LIMITED.
 - OTHER LIMITED APPLICATION AND SHORT DURATION STAGING.

MATERIALS STAGING IN ROADWAY MAINTENANCE NOTES

1. INSPECT BMPs EACH WORKDAY, AND MAINTAIN THEM IN EFFECTIVE OPERATING CONDITION. MAINTENANCE OF BMPs SHOULD BE PROACTIVE, NOT REACTIVE. INSPECT BMPs AS SOON AS POSSIBLE (AND ALWAYS WITHIN 24 HOURS) FOLLOWING A STORM THAT CAUSES SURFACE EROSION, AND PERFORM NECESSARY MAINTENANCE.
2. FREQUENT OBSERVATIONS AND MAINTENANCE ARE NECESSARY TO MAINTAIN BMPs IN EFFECTIVE OPERATING CONDITION. INSPECTIONS AND CORRECTIVE MEASURES SHOULD BE DOCUMENTED THOROUGHLY.
3. WHERE BMPs HAVE FAILED, REPAIR OR REPLACEMENT SHOULD BE INITIATED UPON DISCOVERY OF THE FAILURE.
4. INSPECT PVC PIPE ALONG CURB LINE FOR CLOGGING AND DEBRIS. REMOVE OBSTRUCTIONS PROMPTLY.
5. CLEAN MATERIAL FROM PAVED SURFACES BY SWEEPING OR VACUUMING.

NOTE: MANY JURISDICTIONS HAVE BMP DETAILS THAT VARY FROM UDFCD STANDARD DETAILS. CONSULT WITH LOCAL JURISDICTIONS AS TO WHICH DETAIL SHOULD BE USED WHEN DIFFERENCES ARE NOTED.

(DETAILS ADAPTED FROM AURORA, COLORADO)

Description

Temporary seeding can be used to stabilize disturbed areas that will be inactive for an extended period. Permanent seeding should be used to stabilize areas at final grade that will not be otherwise stabilized. Effective seeding includes preparing a seedbed, selecting an appropriate seed mixture, using proper planting techniques, and protecting the seeded area with mulch, geotextiles, or other appropriate measures.



Photograph TS/PS -1. Equipment used to drill seed. Photo courtesy of Douglas County.

Appropriate Uses

When the soil surface is disturbed and will remain inactive for an extended period (typically determined by local government requirements), proactive stabilization measures, including planting a temporary seed mix, should be implemented. If the inactive period is short-lived (on the order of two weeks), techniques such as surface roughening may be appropriate. For longer periods of inactivity of up to one year, temporary seeding and mulching can provide effective erosion control. Permanent seeding should be used on finished areas that have not been otherwise stabilized.

The USDCM Volume 2 *Revegetation* Chapter contains suggested annual grains and native seed mixes to use for temporary seeding. Alternatively, local governments may have their own seed mixes and timelines for seeding. Check jurisdictional requirements for seeding and temporary stabilization.

Design and Installation

Effective seeding requires proper seedbed preparation, selecting an appropriate seed mixture, using appropriate seeding equipment to ensure proper coverage and density, and protecting seeded areas with mulch or fabric until plants are established.

The USDCM Volume 2 *Revegetation* Chapter contains detailed seed mixes, soil preparation practices, and seeding and mulching recommendations that should be referenced to supplement this Fact Sheet.

Drill seeding is the preferred seeding method. Hydroseeding is not recommended except in areas where steep slopes prevent use of drill seeding equipment, and even in these instances it is preferable to hand seed and mulch. Some jurisdictions do not allow hydroseeding or hydromulching.

Seedbed Preparation

Prior to seeding, ensure that areas to be revegetated have soil conditions capable of supporting vegetation. Overlot grading can result in loss of topsoil and compaction, resulting in poor quality subsoils at the ground surface that

Temporary and Permanent Seeding	
Functions	
Erosion Control	Yes
Sediment Control	No
Site/Material Management	No

EC-2 Temporary and Permanent Seeding (TS/PS)

have low nutrient value, little organic matter content, few soil microorganisms, rooting restrictions, and conditions less conducive to infiltration of precipitation. As a result, it is typically necessary to provide stockpiled topsoil, compost, or other soil amendments and rototill them into the soil to a depth of 6 inches or more.

Topsoil should be salvaged during grading operations for use and spread on areas to be revegetated later. Topsoil should be viewed as an important resource to be utilized for vegetation establishment, due to its water-holding capacity, structure, texture, organic matter content, biological activity, and nutrient content. The rooting depth of most native grasses in the semi-arid Denver metropolitan area is 6 to 18 inches. If present, at a minimum of the upper 6 inches of topsoil should be stripped, stockpiled, and ultimately respread across areas that will be revegetated.

Where topsoil is not available, subsoils should be amended to provide an appropriate plant-growth medium. Organic matter, such as well digested compost, can be added to improve soil characteristics conducive to plant growth. Other treatments can be used to adjust soil pH conditions when needed. Soil testing, which is typically inexpensive, should be completed to determine and optimize the types and amounts of amendments that are required.

If the disturbed ground surface is compacted, rip or rototill the upper 12 inches of the surface prior to placing topsoil. If adding compost to the existing soil surface, rototilling is necessary. Surface roughening will assist in placing a stable topsoil layer on steeper slopes, and allow infiltration and root penetration to greater depth. Topsoil should not be placed when either the salvaged topsoil or receiving ground are frozen or snow covered.

Prior to seeding, the soil surface should be rough and the seedbed should be firm, but neither too loose nor compacted. The upper layer of soil should be in a condition suitable for seeding at the proper depth and conducive to plant growth. Seed-to-soil contact is the key to good germination.

Refer to MHFD's Topsoil Management Guidance for detailed information on topsoil assessment, design, and construction.

Temporary Vegetation

To provide temporary vegetative cover on disturbed areas which will not be paved, built upon, or fully landscaped or worked for an extended period (typically 30 days or more), plant an annual grass appropriate for the time of planting and mulch the planted areas. Temporary grain seed mixes suitable for the Denver metropolitan area are listed in Table TS/PS-1. Native temporary seed mixes are provided in USDCM Volume 2, Chapter 13, Appendix A. These are to be considered only as general recommendations when specific design guidance for a particular site is not available. Local governments typically specify seed mixes appropriate for their jurisdiction.

Permanent Revegetation

To provide vegetative cover on disturbed areas that have reached final grade, a perennial grass mix should be established. Permanent seeding should be performed promptly (typically within 14 days) after reaching final grade. Each site will have different characteristics and a landscape professional or the local jurisdiction should be contacted to determine the most suitable seed mix for a specific site. In lieu of a specific recommendation, one of the perennial grass mixes appropriate for site conditions and growth season listed in seed mix tables in the USDCM Volume 2 *Revegetation* Chapter can be used. The pure live seed (PLS) rates of application recommended in these tables are considered to be absolute minimum rates for seed applied using proper drill-seeding equipment. These are to be considered only as general

recommendations when specific design guidance for a particular site is not available. Local governments typically specify seed mixes appropriate for their jurisdiction.

If desired for wildlife habitat or landscape diversity, shrubs such as rubber rabbitbrush (*Chrysothamnus nauseosus*), fourwing saltbush (*Atriplex canescens*) and skunkbrush sumac (*Rhus trilobata*) could be added to the upland seed mixes at 0.25, 0.5 and 1 pound PLS/acre, respectively. In riparian zones, planting root stock of such species as American plum (*Prunus americana*), woods rose (*Rosa woodsii*), plains cottonwood (*Populus sargentii*), and willow (*Salix spp.*) may be considered. On non-topsoiled upland sites, a legume such as Ladak alfalfa at 1 pound PLS/acre can be included as a source of nitrogen for perennial grasses.

Timing of seeding is an important aspect of the revegetation process. For upland and riparian areas on the Colorado Front Range, the suitable timing for seeding is from October through May. The most favorable time to plant non-irrigated areas is during the fall, so that seed can take advantage of winter and spring moisture. Seed should not be planted if the soil is frozen, snow covered, or wet.

Seeding dates for the highest success probability of perennial species along the Front Range are generally in the spring from April through early May and in the fall after the first of September until the ground freezes. If the area is irrigated, seeding may occur in summer months, as well. See Table TS/PS-2 for appropriate seeding dates.

EC-2 Temporary and Permanent Seeding (TS/PS)

Table TS/PS-1. Minimum Drill Seeding Rates for Various Temporary Annual Grasses

Species ^a (Common name)	Growth Season ^b	Pounds of Pure Live Seed (PLS)/acre ^c	Planting Depth (inches)
1. Oats	Cool	35 - 50	1 - 2
2. Spring wheat	Cool	25 - 35	1 - 2
3. Spring barley	Cool	25 - 35	1 - 2
4. Annual ryegrass	Cool	10 - 15	½
5. Millet	Warm	3 - 15	½ - ¾
6. Winter wheat	Cool	20-35	1 - 2
7. Winter barley	Cool	20-35	1 - 2
8. Winter rye	Cool	20-35	1 - 2
9. Triticale	Cool	25-40	1 - 2

^a Successful seeding of annual grass resulting in adequate plant growth will usually produce enough dead-plant residue to provide protection from wind and water erosion for an additional year. This assumes that the cover is not disturbed or mowed closer than 8 inches.

Hydraulic seeding may be substituted for drilling only where slopes are steeper than 3:1 or where access limitations exist. When hydraulic seeding is used, hydraulic mulching should be applied as a separate operation, when practical, to prevent the seeds from being encapsulated in the mulch.

^b See Table TS/PS-2 for seeding dates. Irrigation, if consistently applied, may extend the use of cool season species during the summer months.

^c Seeding rates should be doubled if seed is broadcast, or increased by 50 percent if done using a Brillion Drill or by hydraulic seeding.

Table TS/PS-2. Seeding Dates for Annual and Perennial Grasses

Seeding Dates	Annual Grasses (Numbers in table reference species in Table TS/PS-1)		Perennial Grasses	
	Warm	Cool	Warm	Cool
January 1–March 15			✓	✓
March 16–April 30		1,2,3	✓	✓
May 1–May 15			✓	
May 16–June 30	5			
July 1–July 15	5			
July 16–August 31				
September 1–September 30		6, 7, 8, 9		
October 1–December 31			✓	✓

Mulch

Cover seeded areas with mulch or an appropriate rolled erosion control product to promote establishment of vegetation. Anchor mulch by crimping, netting or use of a non-toxic tackifier. See the USDCM Volume 2 *Revegetation* Chapter and Volume 3 Mulching BMP Fact Sheet (EC-04) for additional guidance.

Maintenance and Removal

Monitor and observe seeded areas to identify areas of poor growth or areas that fail to germinate. Reseed and mulch these areas, as needed.

If a temporary annual seed was planted, the area should be reseeded with the desired perennial mix when there will be no further work in the area. To minimize competition between annual and perennial species, the annual mix needs time to mature and die before seeding the perennial mix. To increase success of the perennial mix, it should be seeded during the appropriate seeding dates the second year after the temporary annual mix was seeded. Alternatively, if this timeline is not feasible, the annual mix seed heads should be removed and then the area seeded with the perennial mix.

An area that has been permanently seeded should have a good stand of vegetation within one growing season if irrigated and within three growing seasons without irrigation in Colorado. Reseed portions of the site that fail to germinate or remain bare after the first growing season.

Seeded areas may require irrigation, particularly during extended dry periods. Targeted weed control may also be necessary.

Protect seeded areas from construction equipment and vehicle access.

Table A. El Paso County Conservation District All-Purpose Mix for Upland, Transition and Pond Areas

SEED MIX SPECIFICATIONS				<u>Pounds PLS</u>	<u>Pounds PLS</u>	<u>Pounds PLS</u>
Common Name	Scientific Name	Growth Season/Form	% of Mix	<ul style="list-style-type: none"> • Irrigated broadcast • Irrigated hydroseeded (80 seeds/sq ft)	<ul style="list-style-type: none"> • non-irrigated/broadcast • non-irrigated/hydroseeded • irrigated drilled (40 seeds/sq ft)	<ul style="list-style-type: none"> • non-irrigated drilled (20 seeds/sq ft)
Big Bluestem	<i>Andropogon gerardii</i>	Warm, sod	20	4.4	2.2	1.1
Blue Grama	<i>Bouteloua gracilis</i>	Warm, bunch	10	0.5	0.25	0.13
Green Needlegrass (1)	<i>Nassella viridula</i>	Cool, bunch	10	2.0	1.0	0.5
Western Wheatgrass	<i>Pascopyrum smithii</i>	Cool, sod	20	6.4	3.2	1.6
Sideoats Grama	<i>Bouteloua curtipendula</i>	Warm, bunch	10	2.0	1.0	0.5
Switchgrass (1)	<i>Panicum virgatum</i>	Warm, bunch/sod	10	0.8	0.4	0.2
Prairie Sandreed	<i>Calimovilfa longifolia</i>	Warm, sod	10	1.2	0.6	0.3
Yellow Indiangrass (1)	<i>Sorghastrum nutans</i>	Warm, sod	10	2.0	1.0	0.5
Seed rate (lbs PLS/acre)				19.3	9.7	4.8

Description

Vehicle tracking controls provide stabilized construction site access where vehicles exit the site onto paved public roads. An effective vehicle tracking control helps remove sediment (mud or dirt) from vehicles, reducing tracking onto the paved surface.



Photograph VTC-1. A vehicle tracking control pad constructed with properly sized rock reduces off-site sediment tracking.

Appropriate Uses

Implement a stabilized construction entrance or vehicle tracking control where frequent heavy vehicle traffic exits the construction site onto a paved roadway. An effective vehicle tracking control is particularly important during the following conditions:

- Wet weather periods when mud is easily tracked off site.
- During dry weather periods where dust is a concern.
- When poorly drained, clayey soils are present on site.

Although wheel washes are not required in designs of vehicle tracking controls, they may be needed at particularly muddy sites.

Design and Installation

Construct the vehicle tracking control on a level surface. Where feasible, grade the tracking control towards the construction site to reduce off-site runoff. Place signage, as needed, to direct construction vehicles to the designated exit through the vehicle tracking control. There are several different types of stabilized construction entrances including:

VTC-1. Aggregate Vehicle Tracking Control. This is a coarse-aggregate surfaced pad underlain by a geotextile. This is the most common vehicle tracking control, and when properly maintained can be effective at removing sediment from vehicle tires.

VTC-2. Vehicle Tracking Control with Construction Mat or Turf Reinforcement Mat. This type of control may be appropriate for site access at very small construction sites with low traffic volume over vegetated areas. Although this application does not typically remove sediment from vehicles, it helps protect existing vegetation and provides a stabilized entrance.

Vehicle Tracking Control	
Functions	
Erosion Control	Moderate
Sediment Control	Yes
Site/Material Management	Yes

VTC-3. Stabilized Construction Entrance/Exit with Wheel Wash. This is an aggregate pad, similar to VTC-1, but includes equipment for tire washing. The wheel wash equipment may be as simple as hand-held power washing equipment to more advance proprietary systems. When a wheel wash is provided, it is important to direct wash water to a sediment trap prior to discharge from the site.

Vehicle tracking controls are sometimes installed in combination with a sediment trap to treat runoff.

Maintenance and Removal

Inspect the area for degradation and replace aggregate or material used for a stabilized entrance/exit as needed. If the area becomes clogged and ponds water, remove and dispose of excess sediment or replace material with a fresh layer of aggregate as necessary.

With aggregate vehicle tracking controls, ensure rock and debris from this area do not enter the public right-of-way.

Remove sediment that is tracked onto the public right of way daily or more frequently as needed. Excess sediment in the roadway indicates that the stabilized construction entrance needs maintenance.

Ensure that drainage ditches at the entrance/exit area remain clear.

A stabilized entrance should be removed only when there is no longer the potential for vehicle tracking to occur. This is typically after the site has been stabilized.

When wheel wash equipment is used, be sure that the wash water is discharged to a sediment trap prior to discharge. Also inspect channels conveying the water from the wash area to the sediment trap and stabilize areas that may be eroding.

When a construction entrance/exit is removed, excess sediment from the aggregate should be removed and disposed of appropriately. The entrance should be promptly stabilized with a permanent surface following removal, typically by paving.



Photograph VTC-2. A vehicle tracking control pad with wheel wash facility. Photo courtesy of Tom Gore.

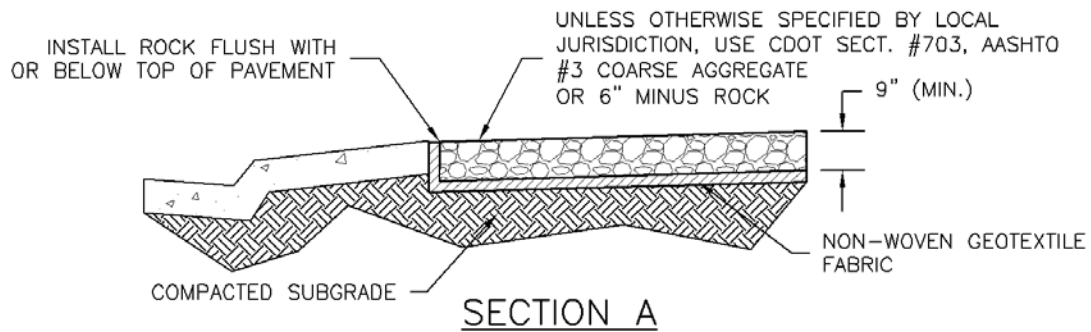
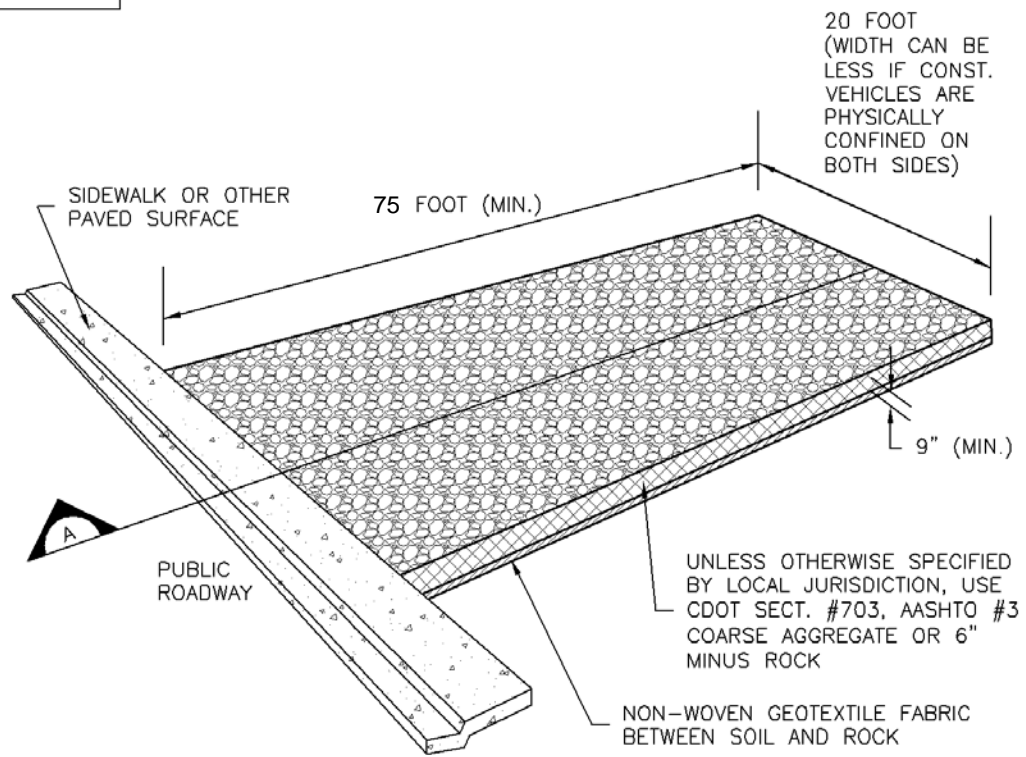
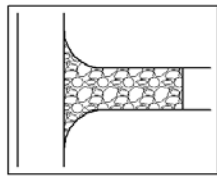

VTC-1. AGGREGATE VEHICLE TRACKING CONTROL

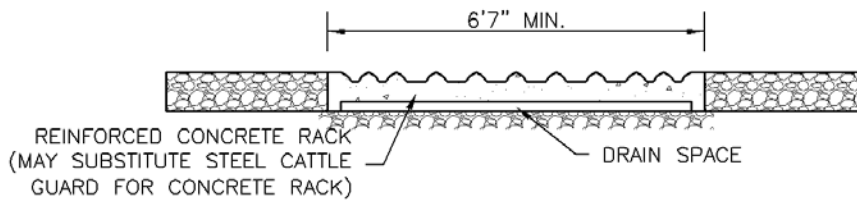
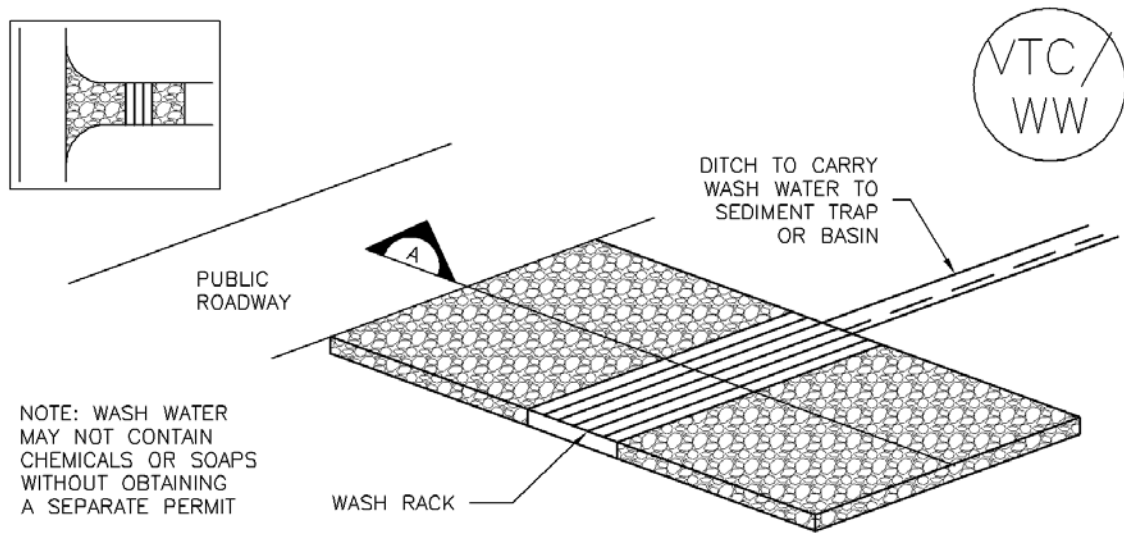

SECTION A

VTC-2. AGGREGATE VEHICLE TRACKING CONTROL WITH WASH RACK

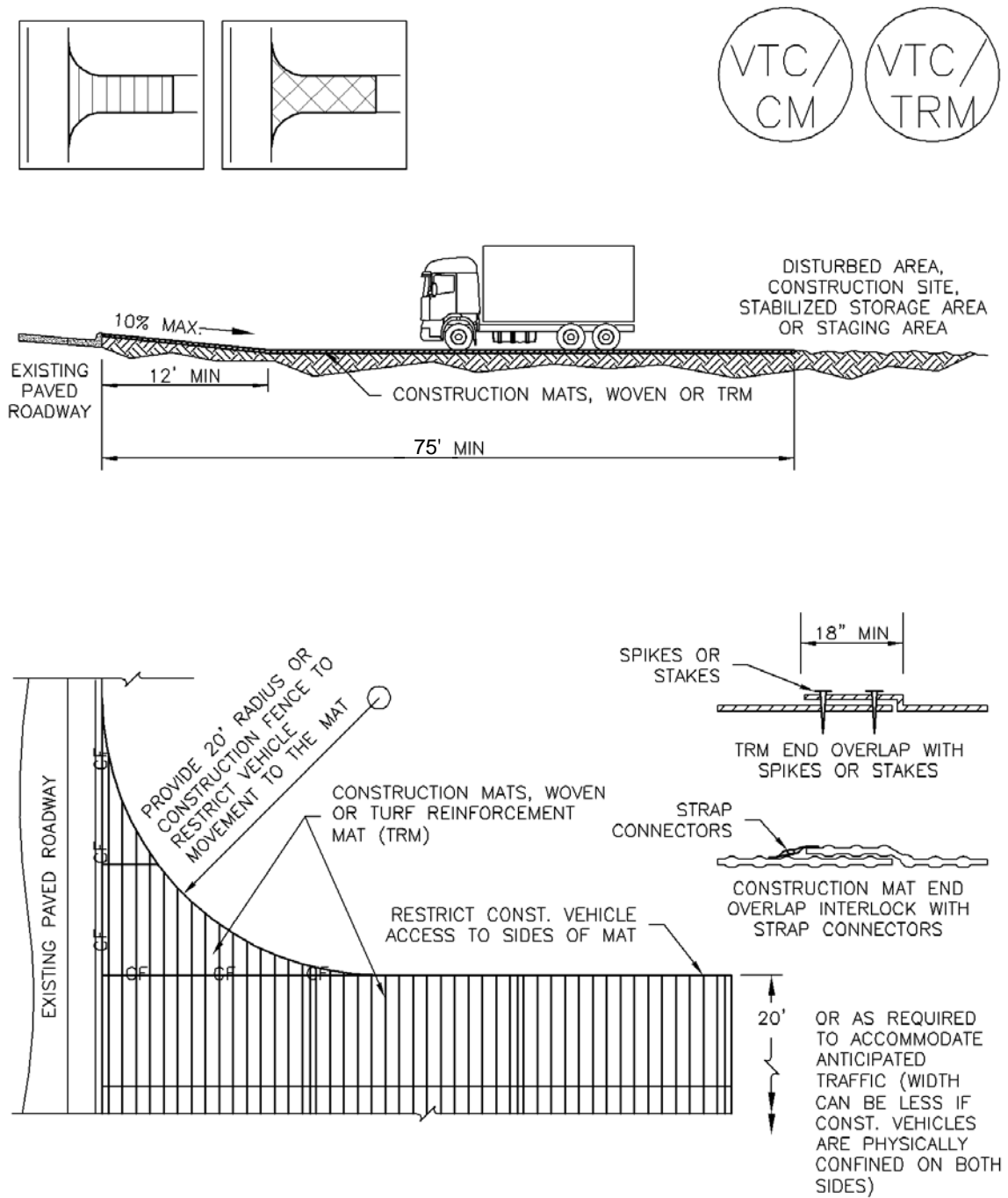

VTC-3. VEHICLE TRACKING CONTROL W/ CONSTRUCTION MAT OR TURF REINFORCEMENT MAT (TRM)

STABILIZED CONSTRUCTION ENTRANCE/EXIT INSTALLATION NOTES

1. SEE PLAN VIEW FOR
 - LOCATION OF CONSTRUCTION ENTRANCE(S)/EXIT(S).
 - TYPE OF CONSTRUCTION ENTRANCE(S)/EXITS(S) (WITH/WITHOUT WHEEL WASH, CONSTRUCTION MAT OR TRM).
2. CONSTRUCTION MAT OR TRM STABILIZED CONSTRUCTION ENTRANCES ARE ONLY TO BE USED ON SHORT DURATION PROJECTS (TYPICALLY RANGING FROM A WEEK TO A MONTH) WHERE THERE WILL BE LIMITED VEHICULAR ACCESS.
3. A STABILIZED CONSTRUCTION ENTRANCE/EXIT SHALL BE LOCATED AT ALL ACCESS POINTS WHERE VEHICLES ACCESS THE CONSTRUCTION SITE FROM PAVED RIGHT-OF-WAYS.
4. STABILIZED CONSTRUCTION ENTRANCE/EXIT SHALL BE INSTALLED PRIOR TO ANY LAND DISTURBING ACTIVITIES.
5. A NON-WOVEN GEOTEXTILE FABRIC SHALL BE PLACED UNDER THE STABILIZED CONSTRUCTION ENTRANCE/EXIT PRIOR TO THE PLACEMENT OF ROCK.
6. UNLESS OTHERWISE SPECIFIED BY LOCAL JURISDICTION, ROCK SHALL CONSIST OF DOT SECT. #703, AASHTO #3 COARSE AGGREGATE OR 6" (MINUS) ROCK.

STABILIZED CONSTRUCTION ENTRANCE/EXIT MAINTENANCE NOTES

1. INSPECT BMPs EACH WORKDAY, AND MAINTAIN THEM IN EFFECTIVE OPERATING CONDITION. MAINTENANCE OF BMPs SHOULD BE PROACTIVE, NOT REACTIVE. INSPECT BMPs AS SOON AS POSSIBLE (AND ALWAYS WITHIN 24 HOURS) FOLLOWING A STORM THAT CAUSES SURFACE EROSION, AND PERFORM NECESSARY MAINTENANCE.
2. FREQUENT OBSERVATIONS AND MAINTENANCE ARE NECESSARY TO MAINTAIN BMPs IN EFFECTIVE OPERATING CONDITION. INSPECTIONS AND CORRECTIVE MEASURES SHOULD BE DOCUMENTED THOROUGHLY.
3. WHERE BMPs HAVE FAILED, REPAIR OR REPLACEMENT SHOULD BE INITIATED UPON DISCOVERY OF THE FAILURE.
4. ROCK SHALL BE REAPPLIED OR REGRADED AS NECESSARY TO THE STABILIZED ENTRANCE/EXIT TO MAINTAIN A CONSISTENT DEPTH.
5. SEDIMENT TRACKED ONTO PAVED ROADS IS TO BE REMOVED THROUGHOUT THE DAY AND AT THE END OF THE DAY BY SHOVELING OR SWEEPING. SEDIMENT MAY NOT BE WASHED DOWN STORM SEWER DRAINS.

NOTE: MANY JURISDICTIONS HAVE BMP DETAILS THAT VARY FROM UDFCD STANDARD DETAILS. CONSULT WITH LOCAL JURISDICTIONS AS TO WHICH DETAIL SHOULD BE USED WHEN DIFFERENCES ARE NOTED.

(DETAILS ADAPTED FROM CITY OF BROOMFIELD, COLORADO, NOT AVAILABLE IN AUTOCAD)



APPENDIX E – SPILL PREVENTION PLAN



Spill Prevention, Control and Countermeasure (SPCC) Plan

Facility Name: _____
Address: _____

Contact Name: _____
Phone: _____
Fax: _____
Email: _____

Certification: I hereby certify that I have examined the facility, and, being familiar with the provisions of 40 CFR part 112, attest that this SPCC plan has been prepared, or updated within 5 years, in accordance with good engineering practices and meets the requirements listed in 40 CFR part 112.

This plan has been certified by:

Date of certification: _____

Engineer's Seal

Copies of this plan are located at the facility and are available to all employees.

Location(s) of plan(s): _____

VII. FACILITY INSPECTIONS

a. Routine Inspections

Name facilities and the frequency with which they are inspected. For example, “The fuel pumps are inspected daily. The materials storage area is inspected monthly.” Describe all facility containers, piping, etc. that is to be inspected. Name the person who has responsibility to implement preventative maintenance programs, oversee on-site inspections, coordinate employee training, maintain records, update the plan as necessary, and ensure that reports are submitted to the proper authorities.

b. Annual Inspections

Include a description of annual comprehensive inspections. For example, “A site inspection is also conducted annually by appropriate responsible personnel to verify that the description of potential pollutant sources are accurate, that the map reflects current site conditions, and that the controls to reduce the pollutants identified in this plan are being implemented and are adequate. This annual inspection will be conducted above and beyond the routine inspections done focusing on designated equipment and areas where potential sources are located.”

VIII. RECORD KEEPING

Describe record keeping procedures. For example, “Record keeping procedures consist of maintaining all records a minimum of three years. The following items will be kept on file: current SPCC plan, internal site reviews, training records, and documentation of any spills or maintenance conducted in regards to these sites.” *Maintenance Inspection, Employee Training, and Record Keeping* logs are included in this template for your use.

X. RECORD KEEPING OF INCIDENTAL SPILLS

Record Keeper: _____. Record Keeper responsibilities include maintaining records of incidents, updating the SPCC plan as necessary and ensuring reports are submitted to the proper authorities when necessary.

Incident No.	Type of Incident	Date of Occurrence	How it was Cleaned Up



Environmental Spill Reporting

*24–Hour Emergency and Incident Reporting Line
Office of Emergency Preparedness & Response*

1-877-518-5608

Updated: June, 2018

Reporting chemical spills and releases in Colorado

General

For all hazardous substance incidents, local emergency response agencies must be notified.

Releases from fixed facilities

The Superfund Amendments and Reauthorization Act (SARA) Title III, requires reporting releases from fixed facilities

Refer to the SARA Title III List of Lists, available from the Environmental Protection Agency (EPA), for the reportable quantity.

The party that owns the spilled material must immediately notify the following agencies or organizations:

- National Response Center (NRC) 1-800-424-8802;
- Colorado Emergency Planning Committee (CEPC), represented by the Colorado Department of Public Health and Environment (CDPHE) 1-877-518-5608; and
- Local Emergency Planning Committee (LEPC) 1-720-852-6600.

In addition to telephone notification, the responsible party must also send written notification describing the release and associated emergency response to both the CEPC (in this case, CDPHE) and the LEPC.

Releases from RCRA facilities

Emergency releases from facilities permitted under the Resource Conservation and Recovery Act (RCRA) are reportable according to the permit requirements.

The permit often requires reporting to CDPHE, even if the amount of the release is less than a reportable quantity under SARA Title III (6 CCR 1007-3 Part 264).

Permitted facilities and generators and transporters of hazardous waste are required to have and implement a contingency plan that describes the actions facility personnel must take in response to fires, explosions or any unplanned sudden or non-sudden release of hazardous waste or hazardous waste constituents to air, soil, surface or ground water at the facility (6 CCR 1007-3 Sections 261, 262, 263, 264 and 265).

Whenever there is an imminent or actual emergency situation, appropriate state or local agencies, with designated response roles as described in the contingency plan, must be notified immediately.

The National Response Center or government official designated as the regional on-scene coordinator must be notified immediately if it is determined that the facility has had a release, fire or explosion that could threaten human health or the environment outside the facility.

CDPHE and local authorities must be notified when the facility is back in compliance and ready to resume operations. In addition, the facility must send a written report to CDPHE within 15 days of any incident that requires implementation of the contingency plan. The contingency plan should include current contact information for notification and submittal of written reports.

Permitted facilities, generators and transporters that store hazardous waste must notify CDPHE within 24 hours of any release to the environment that is greater than one (1) pound and must submit a written report to CDPHE within 30 days of the release (6 CCR 1007-3).

Transportation accidents

Transportation accidents that require reporting:

- Result in a spill or release of a hazardous substance in excess of the reportable quantity (40 CFR Part 302.6)
- Cause injury or death or cause estimated property damage exceeding \$50,000.
- Cause an evacuation of the general public lasting one or more hours.

Those that close or shut down one or more major transportation arteries or facilities or result in fire, breakage, spillage, or suspected contamination from radioactive or infectious substances must immediately be reported to the National Response Center.

Refer to the EPA SARA Title III List of Lists for those substances that have reportable quantities.

In addition to the NRC being notified, the local emergency number (9-1-1) must be called and CDPHE should be notified.

Written notification of any transportation accident involving a release of hazardous materials must be provided to the U.S. Department of Transportation within 30 days (49 CFR Part 171.16)

Since hazardous waste is a subset of hazardous materials, transporters who have discharged hazardous waste must notify the NRC and provide a written report to the US Department of Transportation as noted in the above reporting requirements.

The transporter must give immediate notice to the nearest Colorado State Patrol office (8 CCR 1507-8 HMP 5) and the nearest law enforcement agency if the accident or spill involved a vehicle (42-20-113(3) CRS).

Notification and a written report detailing the ultimate disposition of the discharge of hazardous waste must also be provided to CDPHE (6 CCR 1007-2 Section 263.30). This may be a duplicate copy of the US Department of Transportation report

In the event of a spill or discharge of hazardous waste at a transfer facility, the transporter must notify CDPHE within 24 hours if the spill exceeds 55 gallons or if there is a fire or explosion.

Within 15 days of a reportable incident, the transporter must submit a written report of the incident to CDPHE, including the final disposition of the material (6 CCR 1007-2 Section 263.40).

Releases of hazardous waste at a transfer facility may also require notification to the National Response Center and a written report to the U.S. Department of Transportation.

Releases to water

A release of any chemical, oil, petroleum product, sewage, etc., which may enter waters of the State of Colorado (which include surface water, ground water and dry gullies or storm sewers leading to surface water) must be reported to CDPHE immediately (25-8-601 CRS).

Written notification to CDPHE must follow within five (5) days (5 CCR 1002-61, Section 61.8(5)(d)).

Any accidental discharge to the sanitary sewer system must be reported immediately to the local sewer authority and the affected wastewater treatment plant.

Releases of petroleum products and certain hazardous substances listed under the Federal Clean Water Act (40 CFR Part 116) must be reported to the National Response Center as well as to CDPHE (1-877-518-5608) as required under the Clean Water Act and the Oil Pollution Act.

Releases to air

Any unpredictable failure of air pollution control or process equipment that results in the violation of emission

control regulations should be reported CDPHE by 10 a.m. of the following working day, followed by a written notice explaining the cause of the occurrence and describing action that has been or is being taken to correct the condition causing the violation and to prevent such excess emissions in the future (5 CCR 1001-2 Common Provisions Regulations Section II.E).

If emergency conditions cause excess emissions at a permitted facility, the owner/operator must provide notice to CDPHE no later than noon of the next working day following the emergency, and follow by written notice within one month of the time when emission limitations were exceeded due to the emergency (5 CCR 1001-5, Regulation 3 Part C, Section VII.C.4).

Releases from oil and gas wells

All spills or releases of exploration and production wastes or produced fluids which meet the reporting thresholds of the Colorado Oil and Gas Conservation Commission (COGCC) Rule 906 shall be reported verbally to the COGCC within 24 hours of discovery and on the COGCC Spill/Release Report Form 19 within 72 hours of discovery.

Spills or releases are reportable to the COGCC in the following circumstances:

- 1) the spill or release impacts or threatens to impact any waters of the state, (which include surface water, ground water and dry gullies or storm sewers leading to surface water), a residence or occupied structure, livestock or a public byway;
- 2) a spill or release in which 1 barrel or more is released outside of berms or other secondary containment; or
- 3) any spill or release of 5 barrels or more.

COGCC also requires reportable spills or releases be reported to the surface owner and local government. Whether or not they are reportable, spills or releases of any size must be stopped, cleaned up, and investigated as soon as practicable.

If the spill or release impacts or threatens to impact waters of the state, it must also be reported immediately to CDPHE (25-8-601 CRS).

Releases from storage tanks

Petroleum releases of 25 gallons or more (or any size that causes a sheen on nearby surface waters) from regulated aboveground and underground fuel storage tanks must be reported to the Division of Oil and Public Safety (303-318-8547) within 24 hours. If the report is made after business hours, please leave a message on the technical assistance line for the Division of Oil and Public Safety, and contact the 24 hour CDPHE Emergency and Incident Reporting Line. This includes spills from fuel dispensers.

Spills or releases of hazardous substances from regulated storage tanks in excess of the reportable quantity (40 CFR Part 302.6) must be reported to the National Response Center and the local fire authority immediately, and to the Division of Oil and Public Safety within 24 hours. (8-20.5-208 CRS and 7 CCR 1101-14 Article 4).

Owners/operators of regulated storage tanks must contain and immediately clean up a spill or overfill of less than 25 gallons of petroleum and a spill or overfill of a hazardous substance that is less than the reportable quantity.

If cleanup cannot be accomplished within 24 hours, the Division of Oil and Public Safety must be notified immediately (7 CCR 1101-14 Article 4-4).

CDPHE should also be notified in the case of hazardous substance releases as cleanup activities may be covered by state solid or hazardous waste requirements (6 CCR 1007-2, 6 CCR 1007-3).

Any release that has or may impact waters of the state (which include surface water, ground water and dry

gullies or storm sewers leading to surface water), no matter how small, must be reported immediately to CDPHE (25-8-601 CRS).

Releases from pipelines

Releases of five or more gallons of hazardous liquids or carbon dioxide from a pipeline that result in explosion or fire, cause injury or death or cause estimated property damage (including cost of clean-up and recovery, value of lost product and property damage) exceeding \$50,000 must be reported immediately to the US Department of Transportation Office of Pipeline Safety (49 CFR Part 195 Subpart B) and the National Response Center.

Releases of five or more gallons of hazardous liquids or carbon dioxide from interstate pipelines that do not involve explosion or fire, injury or death or property damage exceeding \$50,000 should be reported to the US Department of Transportation Office of Pipeline Safety within 30 days after the incident.

Releases of natural gas from intrastate pipelines that cause injury or death, property damage in excess of \$50,000 (including the cost of lost product), closure of a public road, or evacuation of 50 or more people must be reported immediately to the Colorado Public Utilities Commission, Pipeline Safety Group (4 CCR 723-11-2).

Releases of natural gas or liquefied natural gas (LNG) from interstate pipelines that cause injury or death, property damage in excess of \$50,000 (including the cost of lost product), or results in an emergency shutdown of the facility must be reported immediately to the National Response Center and the US Dept of Transportation Office of Pipeline Safety.

Releases of oil, petroleum products or other hazardous liquids from interstate and intrastate pipelines that have or may enter waters of the State of Colorado (which include surface water, ground water and dry gullies or storm sewers leading to surface water) must be reported to CDPHE immediately (25-8-601 CRS). CDPHE should also be notified of releases to soil, as cleanup activities may be covered by state solid or hazardous waste requirements (6 CCR 1007-2, 6 CCR 1007-3).

Radiological accidents, incidents, and events

CDPHE must be notified of any condition that has caused or threatens to cause an event, which meets or exceeds the criteria specified in (6 CCR 1007-1) RH 4.51 and RH 4.52 of the State of Colorado *Rules and Regulations Pertaining to Radiation Control*. Reportable events include lost radioactive materials, lost radiation producing machines, over-exposures to persons, contamination events and fires or explosions involving radioactive materials.

Depending upon the severity of the event, notification may be required immediately, within 24 hours, or within 30 days. In most cases, a written follow-up report is also required.

If you are unsure of the proper notification requirement, please contact CDPHE immediately. Telephone event notifications can be made to the CDPHE Radiation Program at any time by calling 1-303-877-9757.

Notification Numbers

Colorado Department of Public Health and Environment toll-free 24-hour environmental emergency and incident reporting line: (877) 518-5608 (24-hour)

National Response Center
(800) 424-8802 (24-hour)

State Oil Inspector (Colorado Division of Oil & Public Safety-Above & Underground Storage Tank Regulators)
(303) 318-8547



Flying Horse Foundation
Stormwater Management Plan
Project No.: 2502010
El Paso County, Colorado

APPENDIX F – SWMP REPORT REVISION LOG





SWMP REPORT REVISION LOG

REVISION #	DATE	BY	COMMENTS

