



LSC TRANSPORTATION CONSULTANTS, INC.  
545 East Pikes Peak Avenue, Suite 210  
Colorado Springs, CO 80903  
(719) 633-2868  
FAX (719) 633-5430  
E-mail: [lsc@lsctrans.com](mailto:lsc@lsctrans.com)  
Website: <http://www.lsctrans.com>

Gardens at North Carefree  
PCD File No. PUD-18-004  
Traffic Impact Analysis  
(LSC #174310)  
October 15, 2018

**Traffic Engineer's Statement**

This traffic report and supporting information were prepared under my responsible charge and they comport with the standard of care. So far as is consistent with the standard of care, said report was prepared in general conformance with the criteria established by the County for traffic reports.



**Developer's Statement**

I, the Developer, have read and will comply with all commitments made on my behalf within this report.

Mule Deer Investments LLC  
by Heath A. Herber  
Manager

10/16/2018  
Date

PUDSP 18-004



LSC TRANSPORTATION CONSULTANTS, INC.  
545 East Pikes Peak Avenue, Suite 210  
Colorado Springs, CO 80903  
(719) 633-2868  
FAX (719) 633-5430  
E-mail: [lsc@lsctrans.com](mailto:lsc@lsctrans.com)  
Website: <http://www.lsctrans.com>

October 16, 2018

Mr. Heath Herber  
Mule Deer Investments  
2727 Glen Arbor Drive  
Colorado Springs, CO 80920

RE: Gardens at North Carefree  
PUDSP-18-004  
El Paso County, Colorado  
Traffic Impact Analysis  
LSC #174310

Dear Mr. Herber,

In response to your request, we have prepared this traffic impact analysis for the proposed Gardens at North Carefree (formerly Mule Deer Villas). The proposed residential development is located south and east of the intersection of North Carefree Circle/Akers Drive in Colorado Springs, Colorado. The site location and vicinity are shown on Figure 2.

## **REPORT CONTENTS**

This report is being prepared for submittal to El Paso County. The purpose of the report is to evaluate the traffic impacts of the development on the intersections of North Carefree Circle/Akers Drive and the intersections on Akers Drive south of North Carefree Circle at which the site will have access. The report contains the following:

- Inventory of the existing adjacent and nearby area street and roadway system, including: surface conditions, functional classifications, roadway/street widths, median configurations, traffic control signs, posted speed limits, pavement markings, intersection spacings, roadway and intersection alignments, auxiliary turn lanes, intersection sight distances, etc.
- Traffic count data at the intersection of North Carefree Circle/Akers Drive and the access to Akers Drive on the south boundary of the site.
- Estimates of future background traffic on the adjacent roadways.
- Projected average weekday and peak-hour vehicle-trips to be generated by the proposed residential development.
- Assignment of the site's projected peak-hour turning movement volumes at the intersection of North Carefree Circle/Akers Drive and each of the two proposed site access points on Akers Drive.

- Intersection level of service analysis and vehicle queuing analysis.
- Evaluation of the *Manual on Uniform Traffic Control Devices (MUTCD)* traffic signal warrants at the intersection of North Carefree Circle/Akers Drive based on the existing peak period traffic volumes and the short- and long-term projected peak period post-development total traffic conditions.
- Auxiliary right- and left-turn lane evaluation based on the projected volumes and criteria in the *Engineering Criteria Manual*.
- Findings and recommendations.

## LAND USE AND ACCESS

The Gardens at North Carefree is a proposed 71-dwelling unit single-family residential development. As shown in Figure 2, the site is located south of North Carefree Circle and east of Akers Drive in El Paso County, Colorado. Access to Akers Drive is proposed via two new site access points located approximately 407 feet south of North Carefree Circle and 350 feet south of Fallow Lane. The site is shown in Figure 2.

The eastbound approach of intersection of Akers Drive/Fallow Lane is currently a right-in/right-out intersection. The plan shows the north site access aligning with Fallow Lane. This site access is proposed to be a three-quarter-movement access. The intersection would be two-way, stop sign-controlled. Full-movement access to Akers Drive would also be provided at a new access across from Running Deer Way. No direct access is proposed to North Carefree Circle.

## ROADWAY AND TRAFFIC CONDITIONS

### Area Roadways

Major roadways in the site vicinity are identified below followed by a brief description of each:

**North Carefree Circle** extends 4.4 miles east from Van Teylingen Drive until it reaches Marksheffel Road. It is classified as a six-lane Principal Arterial adjacent to the site according to the El Paso County *2040 Major Transportation Corridors Plan (MTCP)*. The intersection of North Carefree Circle/Akers Drive is unsignalized, while the posted speed limit is 35 mph east of Akers and 40 mph west of Akers.

**Akers Drive** extends north-to-south and is classified as a Non-Residential Collector by the *MTCP* with a two-way-left-turn-lane (TWLTL) in the center of the roadway. Auxiliary left- and right-turn lanes are already in-place at the proposed site access points. The posted speed limit in the vicinity of the site is 35 mph.

### Existing Traffic Volumes

Vehicular turning movement counts and pedestrian counts were conducted at the following locations at the times specified in Table 1 and are shown in Figure 3. The west leg of the intersection of Akers Drive/Fallow Lane was built as a right-in/right-out access. A right turn channelizing island was installed with the intention of prohibiting left turn movements. However,

several vehicles were observed turning left at this intersection (and counted) despite the right turn island and are included in the existing traffic volumes presented in Figure 3. Raw count data are attached.

**Table 1: Subject Intersection Vehicular Turning Movement Count Data**

Intersection		Data Collection			
Major Street	Minor Street	Day	Date	From	To
N Carefree Circle	Akers Drive	Wednesday	May 10, 2017	6:30 a.m.	8:30 a.m.
				4:00 p.m.	6:00 p.m.
Akers Drive	Running Deer Way	Wednesday	May 10, 2017	6:30 a.m.	8:30 a.m.
				4:00 p.m.	6:00 p.m.
Akers Drive	Fallow Drive	Wednesday	May 10, 2017	6:30 a.m.	8:30 a.m.
				4:00 p.m.	6:00 p.m.
N Carefree Circle	Antelope Ridge Drive	Tuesday	May 9, 2017	6:30 a.m.	8:30 a.m.
				4:00 p.m.	6:00 p.m.

**SIGHT DISTANCE**

Figure 11 graphically presents the following sight distance analysis.

Note: The following sight distance analysis has been based on the posted speed limit in the field and a corresponding design speed of 5 mph over the posted speed limit. The site-specific speed limit at this location has been used as a basis for this analysis rather than the published standard ECM speed limits and design speeds by roadway classification, as the site-specific conditions and existing roadway geometry may not necessarily match all the ECM standard geometric elements and other criteria by general classification.

**Site Access Intersections**

The proposed site access points have been field-measured by LSC for adequate intersection sight distance along Akers Drive. Sight distance would meet the El Paso County *Engineering Criteria Manual* (ECM) 445-foot minimum intersection sight distance standard for a 40-mph (design speed) roadway.

**Akers Drive/North Carefree Circle**

Sight distance to/from the west is greater than one-half mile. The field-measured sight distance to/from the east along North Carefree circle from the northbound approach is 440 feet. This measurement utilized a driver’s eye height of 3.5 feet and a height of 3.5 feet for a westbound vehicle approaching from the east.

### Stopping Sight Distance

Based on the following spot-grades along North Carefree Circle on the westbound approach, the prescribed stopping sight distance is 315 feet (downgrade of 3%). Assuming a 40-mph design speed (35 mph posted speed limit), the field-measured sight distance of 440 feet exceeds the required 315 feet.

### Intersection Sight Distance

Per criteria in Table 2-21 of the *ECM*, the intersection sight distance is a situation requiring special design consideration. Based on the criteria in *A Policy on Geometric Design of Highways and Streets, 6th Edition (Green Book)* by the American Association of State Highway and Transportation Officials (AASHTO) and the number of lanes that must be crossed to complete the left-turn movement, the prescribed sight distance for passenger vehicles for the northbound left-turn movement is 530 feet. This field-measured sight distance for passenger vehicles (440 feet) is short of the AASHTO intersection sight distance. There is already an “intersection ahead” warning sign installed on the westbound approach due to the short intersection sight distance. Given the T-intersection configuration and the raised center median width, there is some useable “refuge” area for northbound left turns.

## **TRIP GENERATION**

Estimates of the vehicle-trips projected to be generated by the Gardens at North Carefree have been made using the nationally published trip generation rates from *Trip Generation, 10<sup>th</sup> Edition, 2017* by the Institute of Transportation Engineers (ITE). Land use code “210 – Single-Family Detached Housing” was categorized using the *Trip Generation Manual, 10<sup>th</sup> Edition, 2017* by the Institute of Transportation Engineers (ITE) and used for trip generation estimates. Published ITE methodology has been used to calculate the trip rates. Details are attached for reference.

The Gardens at North Carefree is expected to generate about 759 vehicle-trips on the average weekday (one-half entering and one-half exiting in a 24-hour period). During the morning peak hour, 14 vehicles are projected to enter the site while 41 are projected to exit. Approximately 46 vehicles would enter and 27 vehicles would exit the site during the evening peak hour. The morning peak hour generally occurs for one hour between 6:30 and 8:30 a.m., and the afternoon peak hour occurs for one hour between 4:00 and 6:00 p.m. Table 2 shows a summary of the results of the trip generation estimate. A detailed trip generation estimate for the development, including ITE rates for the proposed land use is presented in Table 13 (attached).

**Table 2: Estimated Site Vehicle-Trip Generation**

<b>Analysis Period</b>	<b>In</b>	<b>Out</b>	<b>Total</b>
Morning Peak Hour (vehicle-trips/hour)	14	41	55
Evening Peak Hour (vehicle-trips/hour)	46	27	73
Weekday (vehicle-trips/day)	380	380	759
* Please refer to Table 13 (attached) for detailed trip generation table			

### Trip Distribution and Assignment

An estimate of the directional distribution of site-generated vehicle-trips to the study area streets and intersections is a necessary component in determining the site’s traffic impacts. Figure 4 shows the directional distribution estimate for the site-generated trips and the percentages of the site-generated vehicle-trips projected to be oriented to and from the site’s major approaches. Estimates were based on the following factors: traffic counts conducted at nearby intersections on Akers Drive, the proposed land use and access plan, the area street system serving the site, the site’s geographic location, and projected traffic growth in the area.

### Site-Generated Traffic

The site-generated traffic volumes at the intersections of Akers Drive with North Carefree Circle and at the two proposed site access points have been calculated by applying the directional distribution percentages estimated by LSC (from Figure 4) to the trip generation estimates (from Table 1). Figure 5 shows the projected site-generated traffic volumes for the morning and evening peak hours.

### EXISTING AND PROJECTED LEVELS OF SERVICE

Level of service (LOS) is a quantitative measure of the level of congestion or delay at an intersection and is indicated on a scale from “A” to “F.” LOS A is indicative of little congestion or delay. LOS F indicates a high level of congestion or delay. Table 3 shows the level of service delay ranges for signalized and unsignalized intersections.

**Table 3: Intersection Levels of Service Delay Ranges**

Level of Service	Signalized Intersections		Unsignalized Intersections
	Average Control Delay (seconds per vehicle)	V/C <sup>(1)</sup>	Average Control Delay (seconds per vehicle) <sup>(2)</sup>
A	≤ 10.0	< 0.60	≤ 10.0
B	10.1 – 20.0	0.60 – 0.69	10.1 – 15.0
C	20.1 – 35.0	0.70 – 0.79	15.1 – 25.0
D	35.1 – 55.0	0.80 – 0.89	25.1 – 35.0
E	55.1 – 80.0	0.90 – 0.99	35.1 – 50.0
F	≥ 80.1	≥ 1.00	≥ 50.1

(1) Source: *Transportation Research Circular 212*  
 (2) For unsignalized intersections, if V/C is > 1.00, then LOS is LOS F regardless of the projected average control delay per vehicle

Each study area intersection has been analyzed to determine the projected levels of service and control delay for turning movements and overall with signalized intersection analysis. This section includes LOS summary tables with the results for the most important intersection turning movements. Please refer to the attached LOS calculation worksheets for complete LOS analysis assumptions and results.








**Existing Plus Site-Generated Traffic Volumes**

Figure 6 shows the short-term total weekday traffic volumes, which are the sum of the site-generated weekday traffic volumes (from Figure 5) and the 2017 existing background weekday traffic volumes (from Figure 3).

**Morning Peak Hour**

All major and minor street left-turning movements within the study area are projected to operate at LOS D or better during all short-term traffic scenarios. A summary of current and projected existing plus site-generated LOS and control delays during the morning peak hour is shown in Table 4.








**Table 4: Unsignalized Level of Service Comparison by Scenario (2017 A.M.)**

Scenario	Akers Dr/ N Carefree Cir					Akers Dr/ Fallow Dr		Akers Dr/ Running Deer	
	Traffic Control	Overall	NBL	NBR	WBL	WBR	SBL	WB	SBL
									
LOS									
2017 Existing	Stop Sign	-	D	B	B	-	-	-	-
2017 Existing + Site	Stop Sign	-	D	B	B	A	A	B	A
Control Delay (Seconds)									
2017 Existing	Stop Sign	-	29.6	12.1	12.2	-	-	-	-
2017 Existing + Site	Stop Sign	-	34.6	12.4	12.3	9.5	7.7	11.6	7.6

**Evening Peak Hour**

The northbound left- and westbound left-turning movements at the intersection of Akers Drive and North Carefree Circle currently operate at LOS B or better and are projected to remain at LOS C or better once site-generated traffic is considered. All minor street left-turning movements at the proposed site access points are projected to operate at LOS B or better during the evening peak hour, both before and after site-generated trips are considered. A summary of current and projected existing plus site-generated LOS and control delays during the evening peak hour is shown in Table 5.

**Table 5: Unsignalized Level of Service Comparison by Scenario (2017 P.M.)**

Scenario	Akers Dr/ N Carefree Cir					Akers Dr/ Fallow Dr		Akers Dr/ Running Deer	
	Traffic Control	Overall	NBL	NBR	WBL	WBR	SBL	WB	SBL
									
<b>LOS</b>									
2017 Existing	Stop Sign	-	B	B	A	-	-	-	-
2017 Existing + Site	Stop Sign	-	C	B	A	A	A	B	A
<b>Control Delay (Seconds)</b>									
2017 Existing	Stop Sign	-	14.4	10.3	9.6	-	-	-	-
2017 Existing + Site	Stop Sign	-	15.5	10.4	9.8	9.3	7.7	10.5	7.6

## 2040 FUTURE CONDITIONS

### Background Traffic

Background traffic is the traffic estimated to be on the study area street system without consideration of the proposed development. Through traffic and traffic generated by existing and future nearby developments is included, but all traffic generated by the site is ignored for background traffic. Figure 7 shows estimates of year 2040 background traffic volumes. Background traffic volumes for North Carefree Circle have been based on previous studies by LSC for developments along Antelope Ridge Drive north of North Carefree Circle. These volumes may be conservative and will depend on the timing of the extension of North Carefree east of Marksheffel and the future development within Banning Lewis Ranch. It is unlikely that traffic volumes on North Carefree would reach these projected levels (approximately 30,000 vehicles per day, which represents a growth factor of 3.75) without the extension of North Carefree east of Marksheffel and significant development trip generation within Banning Lewis Ranch. Traffic volumes along Akers Drive have been based on anticipated future other development along Akers Drive, primarily near Constitution Avenue.

### Total Traffic

Figure 8 shows the year 2040 total traffic volumes. The 2040 total weekday traffic volumes are the sum of the site-generated weekday traffic volumes (from Figure 5) and the 2040 background weekday traffic volumes (from Figure 7).


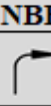
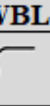


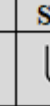

### Morning Peak Hour

The northbound left-turn lane at the intersection of North Carefree Circle/Akers Drive is projected to operate at LOS F during the 2040 morning peak hour, before and after considering site-generated traffic. However, all turning movements at this intersection are projected to operate at LOS C or better with considerably less control delay if the intersection were to be signalized. All left-turning movements at the two site access intersections are projected to operate at LOS B or better during both long-term scenarios. A summary of projected 2040 existing plus site-generated LOS and



control delays for each turning movement during both morning peak-hour scenarios is shown in Table 6.








**Table 6: Level of Service Comparison by Scenario (2040 A.M.)**

Scenario	Akers Dr/ N Carefree Cir			Akers Dr/ Fallow Dr			Akers Dr/ Running Deer		
	Traffic Control	Overall	NBL	NBR	WBL	WBR	SBL	WB	SBL
									
LOS									
2040 Background	Stop Sign	-	F	C	C	-	-	-	-
2040 Background + Site	Stop Sign	-	F	C	C	B	A	B	A
	Signal	A	C	B	A	B	A	B	A
Control Delay (Seconds)									
2040 Background	Stop Sign	-	667.3*	19.5	19.2	-	-	-	-
2040 Background + Site	Stop Sign	-	884.0*	21	19.7	10.7	8.1	14.6	7.9
	Signal	6.7	20.9	10.4	8	10.1	7.9	12.7	7.8
* Synchro HCM-calculated control delays are in the LOS F range									
Reported delay value from formula-based calculation procedures									
Actual delay is not likely to reach this level of control delay (exceeds realistic levels)									
For additional detail, please refer to the attached HCM calculation sheets									

**Evening Peak Hour**

The northbound left-, northbound right-, and westbound left-turn lanes at the intersection of North Carefree Circle/Akers Drive are all projected to operate at LOS F during the 2040 morning peak hour, before and after considering site-generated traffic. However, all turning movements at this intersection are projected to operate at LOS C or better with considerably less control delay if the intersection were to be signalized. All left-turning movements at the two site access intersections are projected to operate at LOS C or better during both long-term scenarios. A summary of projected 2040 existing plus site-generated LOS and control delays for each turning movement during both evening peak hour scenarios is shown in Table 7.

**Table 7: Level of Service Comparison by Scenario (2040 P.M.)**

Scenario	Akers Dr/ N Carefree Cir					Akers Dr/ Fallow Dr		Akers Dr/ Running Deer	
	Traffic Control	Overall	NBL	NBR	WBL	WBR	SBL	WB	SBL
									
<b>LOS</b>									
2040 Background	Stop Sign	-	F	F	F	-	-	-	-
2040 Background + Site	Stop Sign	-	F	F	F	B	A	C	A
	Signal	B	C	A	A	B	A	B	A
<b>Control Delay (Seconds)</b>									
2040 Background	Stop Sign	-	9,534.7*	109.3	73.3	-	-	-	-
2040 Background + Site	Stop Sign	-	17,510.3*	116.6	92.9	11.6	8.6	17.9	8.5
	Signal	10	22.2	6.1	7.8	10.3	8.1	14.4	8
* Synchro HCM-calculated control delays are in the LOS F range									
Reported delay value from formula-based calculation procedures									
Actual delay is not likely to reach this level of control delay (exceeds realistic levels)									
For additional detail, please refer to the attached HCM calculation sheets									

**TRAFFIC SIGNAL WARRANT ANALYSIS**

The intersection of North Carefree Circle/Akers Drive has the potential to meet a warrant(s) for a traffic control signal in the future. The combination of major street approach volumes (includes the sum of eastbound and westbound approach volumes) and minor street volumes (northbound approach) were analyzed to determine if the combination would exceed the threshold criteria for Four-Hour and/or Eight-Hour Vehicular Volume Traffic Signal Warrants in the *2009 Manual on Uniform Traffic Control Devices (MUTCD)*.

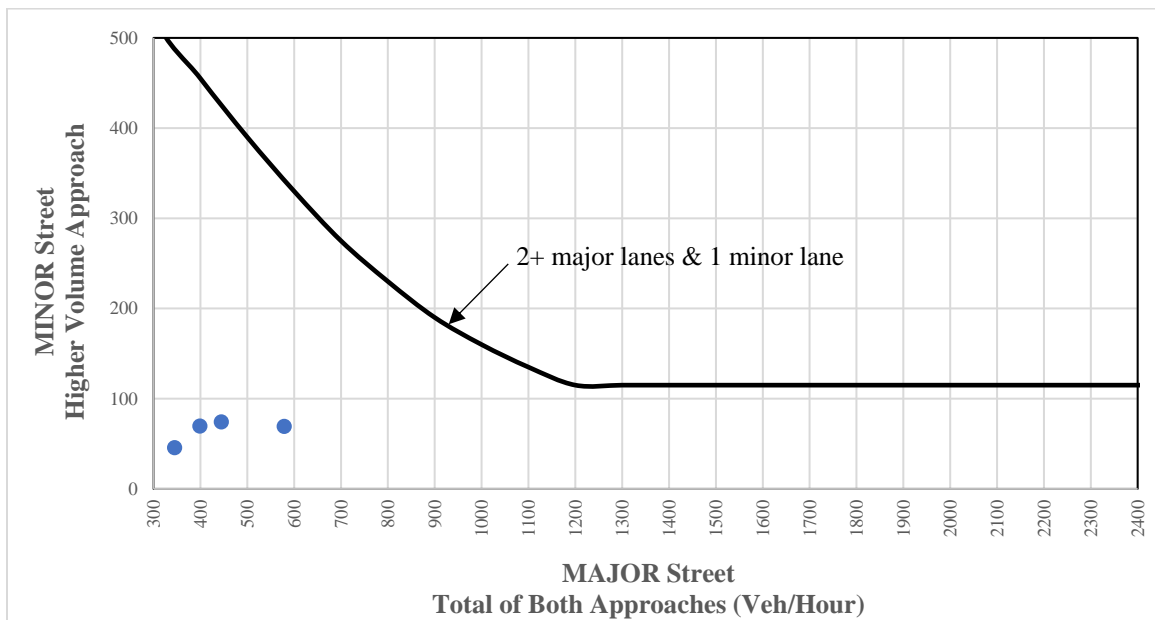
Two one-hour periods during the morning peak period and two one-hour periods during the afternoon peak period have been analyzed:

- 6:30 – 7:30 a.m.
- 7:30 – 8:30 a.m.
- 4:00 – 5:00 p.m.
- 5:00 – 6:00 p.m.

**Four-Hour Vehicular Volume Traffic Signal Warrant**

2017 Existing Plus Site-Generated Traffic

Results from the four-hour traffic signal warrant analysis for the existing plus site-generated traffic scenario are shown in the Warrant 2, Four-Hour Vehicular Volume (MUTCD Figure 4C-1) signal warrant chart in Figure 9. Fewer than four separate major/minor street volumes fell above the minimum threshold curve for an intersection with two lanes for the major approach and two lanes for the minor (southbound) approach. As a result, the Four-Hour Vehicular Volume Traffic Signal Warrant threshold at the intersection of North Carefree Circle/Akers Drive **are not** projected to be exceeded during the two-hour morning and two-hour evening peak periods based on the short-term existing plus site-generated traffic scenario.



**Figure 9: MUTCD Warrant 2, 4-Hour Vehicular Volume**

Table 8 shows the major/minor street volume combinations plotted in Figure 9.

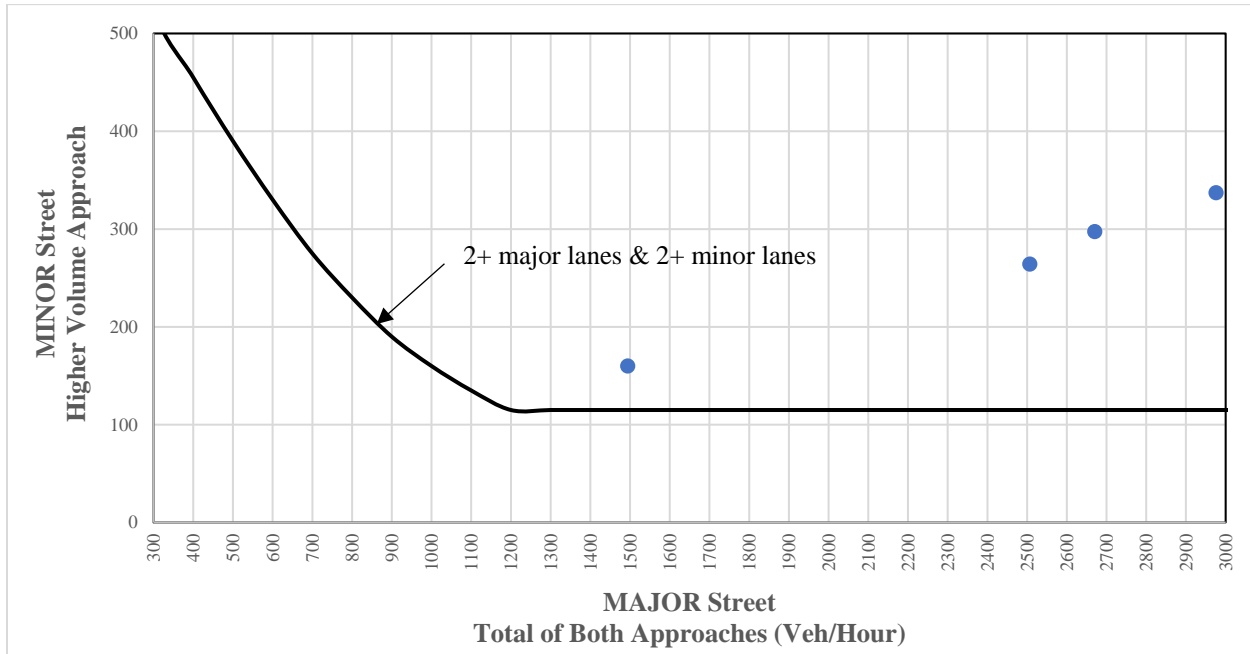
**Table 8: Major/Minor Street Volumes for Signal Warrants (2017 Existing + Site)**

Start	End	Major Street Volume	Minor Street Volume*	4-Hour Warrant Threshold Met?
6:30	7:30	345	46	No
7:30	8:30	579	69	No
4:00	5:00	399	70	No
5:00	6:00	445	74	No
<i># of hours meeting respective warrant thresholds/hours required to satisfy the warrant (warrant satisfied?)</i>				<b>0 / 4 (No)</b>
* Based on alternate methodology using the northbound left-turn lane only as the minor street				

2040 Background Plus Site-Generated Traffic

Results from the four-hour traffic signal warrant analysis for the projected 2040 background plus site-generated traffic scenario are shown in the Warrant 2, Four-Hour Vehicular Volume (MUTCD Figure 4C-1) signal warrant chart in Figure 10. Four separate major/minor street volumes (for the two-hour morning peak and two-hour evening peak periods) are projected to exceed the minimum threshold curve for an intersection with two lanes for the major approach and two lanes for the minor (northbound) approach. As a result, the intersection of North Carefree Circle/Akers Drive **has the potential** to meet the threshold for a Four-Hour Vehicular Volume Traffic Signal Warrant by 2040.

Assuming a linear vehicular volume growth rate between the existing and projected 2040 traffic scenarios, this intersection is projected to satisfy MUTCD signal warrant thresholds in 2033 (background plus site-generated) and 2034 (background only).



**Figure 10: MUTCD Warrant 2, 4-Hour Vehicular Volume**

Table 8 shows the major/minor street volume combinations plotted in Figure 10.

**Table 9: Major/Minor Street Volumes for Signal Warrants (2040 Background + Site)**

Start	End	Major Street Volume	Minor Street Volume*	4-Hour Warrant Threshold Met?
6:30	7:30	1495	160	Yes
7:30	8:30	2507	264	Yes
4:00	5:00	2671	297	Yes
5:00	6:00	2976	337	Yes
<i># of hours meeting respective warrant thresholds/hours required to satisfy the warrant (warrant satisfied?)</i>				<b>4 / 4 (Yes)</b>
* Both the right- and left-turn minor street volumes have been used in this analysis. A right-turn adjustment factor was not applied despite the separate right-turn lane due to the projected low LOS for the northbound right-turn movement.				

**QUEUING ANALYSIS**

A queuing analysis was conducted using Synchro/SimTraffic to estimate the vehicle queue lengths for key approaches at the intersection of North Carefree Circle/Akers Drive.

Available stacking distance is limited to 175 feet for the westbound left-turn lane due to the presence of back-to-back turn lanes on North Carefree Circle between Antelope Ridge Drive and Akers Drive. Based on the projected northern site access location, approximately 250 feet of storage is available for northbound left-turning vehicles.

**2017 Existing/Existing Plus Site**

Projected queue lengths would be accommodated during both the 2017 morning and evening peak hours, before and after site buildout. Table 10 shows the queuing analysis results for the 2017 and 2040 morning peak hours after accounting for site-generated traffic. Detailed queuing reports are attached.

**Table 10: Projected vs. Available Storage Lengths (2017)**

Traffic Scenario	Traffic Control	NBL				WBL			
		Available	Projected	Storage Block Time (%)	Upstream Block Time (%)	Available	Projected	Storage Block Time (%)	Upstream Block Time (%)
<b>AM</b>									
2017 Existing	Stop Sign	250'	132'	0%	0%	175'	174'	0%	0%
2017 Existing + Site		250'	172'	0%	0%	175'	95'	0%	0%
<b>PM</b>									
2017 Existing	Stop Sign	250'	87'	0%	0%	175'	29'	0%	0%
2017 Existing + Site		250'	175'	0%	0%	175'	50'	0%	0%

**2040 Background/Background Plus Site**

If the intersection of North Carefree Circle/Akers Drive were to remain stop-controlled, the northbound left-turning movement queue is projected to exceed the available 250 feet of storage 100 percent of the time during both peak hours. Westbound left-turning vehicles are projected to have a maximum queue that exceeds the available stacking distance during both 2040 evening peak hours upon site buildout.

Installing a traffic signal at the intersection would eliminate upstream storage lane block time for both the northbound and westbound left-turn lanes. The maximum projected northbound left queue would decrease to 109 feet during both the 2040 morning and evening peak hours upon site buildout.

Table 11 shows the queuing analysis results for the 2040 morning and evening peak hours after accounting for site-generated traffic. Detailed queuing reports are attached.

**Table 11: Projected vs. Available Storage Lengths (2040)**

Traffic Scenario	Traffic Control	NBL				WBL			
		Available	Projected	Storage Block Time (%)	Upstream Block Time (%)	Available	Projected	Storage Block Time (%)	Upstream Block Time (%)
<b>AM</b>									
2040 Background	Stop Sign	250'	323'	0%	100%	175'	76'	0%	0%
2040 Background + Site		250'	324'	0%	100%	175'	93'	0%	0%
2040 Background + Site	Signal	250'	109'	0%	0%	175'	130'	0%	0%
<b>PM</b>									
2040 Background	Stop Sign	250'	310'	0%	100%	175'	225'	23%	0%
2040 Background + Site		250'	324'	0%	100%	175'	225'	64%	0%
2040 Background + Site	Signal	250'	109'	0%	0%	175'	97'	0%	0%

**CONCLUSIONS AND RECOMMENDATIONS**

**Trip Generation**

The proposed development is projected to generate about 759 vehicle-trips on the average weekday during a 24-hour period. During the morning peak hour, approximately 14 vehicles would enter and 41 vehicles would exit the site. During the evening peak hour, approximately 46 vehicles would enter while 27 vehicles would exit the site.

**Projected Future Background Traffic**

Projections of future baseline/background traffic along North Carefree Circle (and resulting “total” traffic volumes with the addition of traffic generated by this site) may be conservative. Year 2040 volumes will largely depend on the timing of the future extension of North Carefree east of Marksheffel and future development within Banning Lewis Ranch in the general vicinity. It is unlikely that traffic volumes on North Carefree would reach the levels projected in this analysis

(approximately 30,000 vehicles per day) without the extension of North Carefree east of Marksheffel and significant development trip generation within Banning Lewis Ranch.

### **Level of Service Analysis**

Level of service analysis at the intersection of North Carefree Circle/Akers Drive and the two site access points along Akers Drive is presented in Table 4 through Table 7. The northbound left turning movements are projected to operate at LOS F during the evening peak hour based on the 2040 background and background plus site-generated traffic scenarios. All other turning movements are projected to operate at LOS C or better for these and the short-term traffic scenarios.

A traffic signal would improve the projected future LOS F at the currently stop-controlled (northbound approach) intersection of North Carefree Circle/Akers Drive, improving all approaches to LOS C or better in 2040 during both the morning and afternoon peak hours, with and without consideration of site-generated traffic. Detailed Synchro analysis results are attached.

### **Traffic Signal Warrant Analysis**

The **Four-Hour Vehicular Volume** signal warrant is not likely currently warranted at the intersection of North Carefree Circle/Akers Drive based on the analysis contained in this report. However, the intersection has the potential to meet warrants by 2040 based on the warrant threshold analysis of projected morning and afternoon peak-hour volumes. Please refer to the Traffic Signal Warrant Analysis section for details. Traffic signal warrants are guidelines. A decision to install this traffic signal and the timing of installation rests with El Paso County. Other alternatives could be considered, such as modification of the median on the west leg of the intersection to create a left-turn acceleration lane/channelized T-intersection. Median width and available right-of way along North Carefree appear to be limited. Given right-of-way constraints, it does not appear that a modern roundabout intersection would be an option. Moreover, North Carefree is a six-lane street.

### **Queuing Analysis**

Projected queue lengths would be accommodated during both the 2017 morning and evening peak hours, before and after site buildout (existing plus site-generated traffic scenario).

If the intersection of North Carefree Circle/Akers Drive were to remain stop-controlled, the northbound left-turning movement queue is projected to exceed the available 250 feet of storage during both peak hours. Installing a traffic signal at the intersection would eliminate upstream storage lane block time for both the northbound and westbound left-turn lanes.

### **Akers Drive/Fallow Lane/Site Access Intersection**

The eastbound approach of the intersection of Akers Drive/Fallow Lane is configured as a right-in/right-out. The plan shows the site access aligning with Fallow Lane. The site access is proposed as three-quarter movement and the west leg of the intersection would remain a right-in/right-out.

The intersection would be two-way, stop sign-controlled. Auxiliary left- and right-turn deceleration lanes have already been provided at the site access points. Some restriping of sections of Akers Drive (north of Running Deer Way) will be required due to the north access shift to the south to align with Fallow Lane. Corresponding traffic sign modifications may also be necessary.

### **North Carefree Circle/Akers Drive**

The westbound left-turn lane at this intersection would provide sufficient stacking distance for the projected future queue length. However, given the intersection spacing constraint (the distance between Akers and Antelope Ridge Drive), full deceleration plus peak period stacking distance is not feasible. This should not be problematic.

### Sight Distance

Stopping sight distance at this intersection meets the El Paso County *Engineering Criteria Manual (ECM)* 325-foot minimum standard for a 40-mph design speed roadway. The field-measured sight distance for passenger vehicles is short of the AASHTO intersection sight distance. There is already an “intersection ahead” warning sign installed on the westbound approach due to the short intersection sight distance. Given the T-intersection configuration and the raised center median width, there is some useable “refuge” area for northbound left turns.

### Traffic Signal Contribution

Based on Table 12, this project’s estimated percentage for use in calculating a fair-share amount toward a future traffic signal at the intersection of North Carefree Circle/Akers Drive is 6.5 percent. This is based on the 2040 projected site traffic volumes on the northbound approach to the intersection divided by the projected 2040 total traffic volumes for this same approach. The calculation utilized a weighted average of all four sets of projected hourly volumes utilized in the traffic signal warrant.

Since the previous version of this report (which included the above paragraph), discussions have taken place at the El Paso County Road Impact Fee Program Steering Committee regarding development project escrows for future signals. The discussions have involved potentially eliminating such escrows subject to certain conditions. Instead, the fee amount would be increased to cover the addition of County signals to the fee program. It is our understanding that this potential change may apply to this project.



**Table 12: Estimated Fair-Share Percentage Contribution Toward a Future Signal**

<b>North Carefree/Akers</b>						
<b>Hour</b>	<b>Start</b>	<b>End</b>	<b>Major Streets Total Volume</b>	<b>Minor Street (NB) Volumes</b>		
				<b>Total Approach</b>	<b>Site-Generated</b>	<b>% Site of Total</b>
1	6:00	7:00	1495	159	17	11%
2	7:00	8:00	2507	262	27	10%
3	4:00	5:00	2671	298	12	4%
4	5:00	6:00	2976	338	13	4%
<b>Weighted Avg of the Four Hours Analyzed</b>						<b>6.5%</b>

**El Paso County Transportation Improvement Fee Program**

This project will be required to participate in the County Transportation Improvement Fee Program.

\* \* \* \* \*

Please contact me if you have any questions or need further assistance.

Sincerely,

LSC TRANSPORTATION CONSULTANTS, INC.

By: Jeffrey C. Hodsdon, P.E., PTOE  
Principal

JCH:JAB:bjwb

Enclosures: Table 13  
Figures 1-8, 11  
Traffic Count Reports  
Level of Service Reports  
Queue Reports  
ITE Trip Generation Rate Methodology  
Peak Hour Factor Calculations

**Table 13: Detailed Trip Generation Estimate**

ITE		Trip Generation Rates <sup>(1)</sup>				Total Trips Generated							
Code	Description	Value	Units	Average Weekday Traffic	A.M.		P.M.		Average Weekday Traffic	A.M.		P.M.	
					In	Out	In	Out		In	Out	In	Out
210	Single-Family Detached Housing	71	DU <sup>(2)</sup>	10.69	0.19	0.58	0.65	0.38	759	14	41	46	27

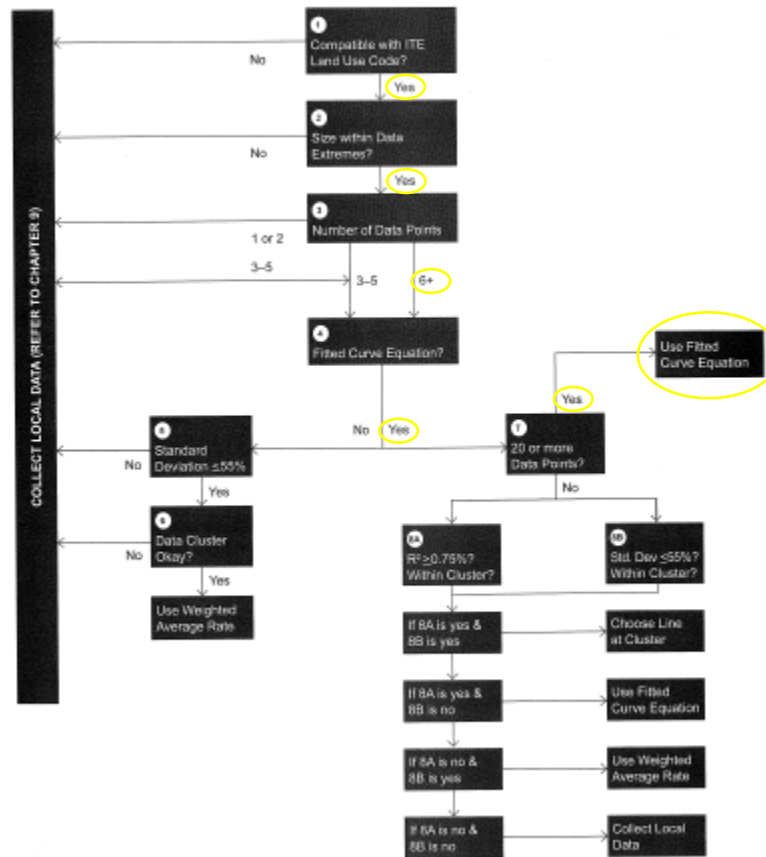
(1) Source: *Trip Generation, 10<sup>th</sup> Edition, 2017* by the Institute of Transportation Engineers (ITE)

(2) DU = dwelling units

Use the flow chart on page 28 of the *Trip Generation Handbook, 3rd Ed.* to determine when to use avg or fitted rates. Figure 4.2 - Process for Selecting Average Rate or Equation in Trip Generation Manual contains the following flow chart criteria:

- # of data points = 6+ (159 studies)
- Fitted curve equation = Yes
- 20+ data points = Yes

Figure 4.2 Process for Selecting Average Rate or Equation in Trip Generation Manual Data



Because all the above criteria are met, the fitted equation, **not** the average rate equation, should be used. Per the 10th Edition ITE *Trip Generation Manual*, the fitted equation for 210 – Single-Family Detached Housing is:

$$\ln(T) = 0.92\ln(X) + 2.71$$

After substituting X = 71 into the equation above, the result is T = 10.69, meaning each of the 71 dwelling units generates 10.69 trips/day.

$$10.69 \times 71 = 759 \text{ trips/day}$$

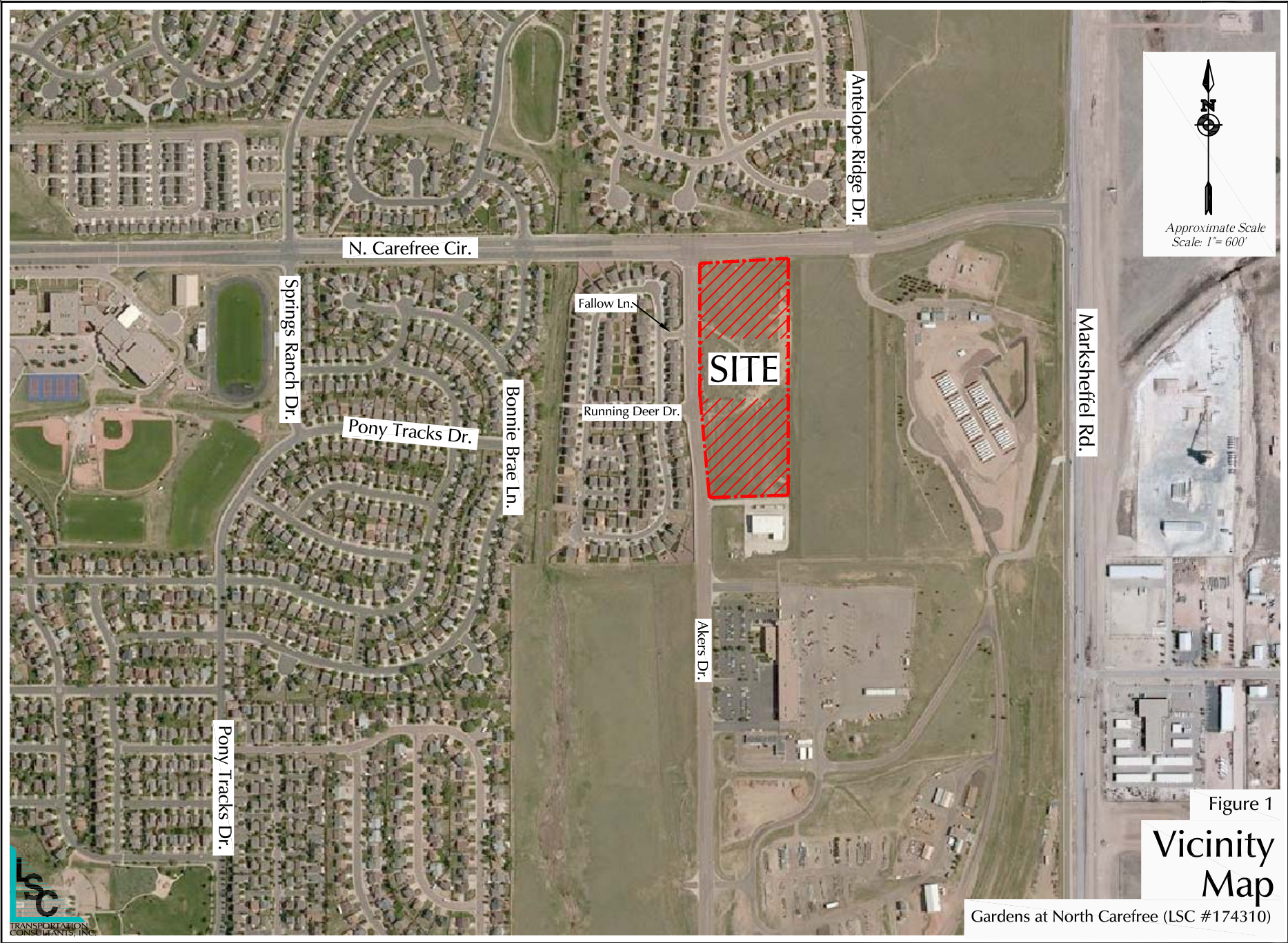


Figure 1

# Vicinity Map

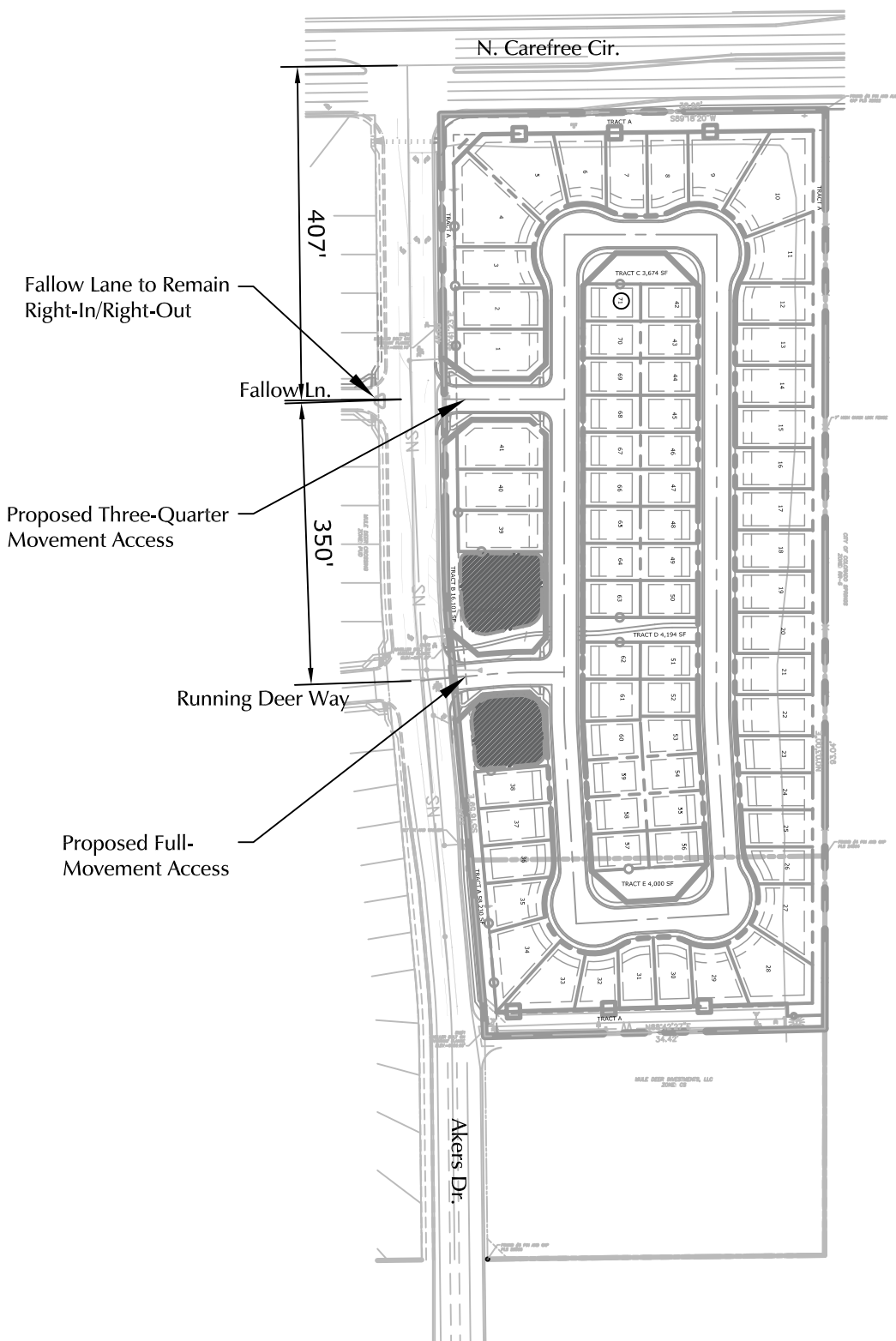
Gardens at North Carefree (LSC #174310)







Approximate Scale  
Scale: 1" = 200'



Fallow Lane to Remain Right-In/Right-Out

Fallow Ln.

Proposed Three-Quarter Movement Access

350'

Running Deer Way

Proposed Full-Movement Access

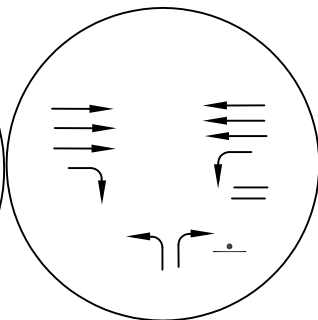
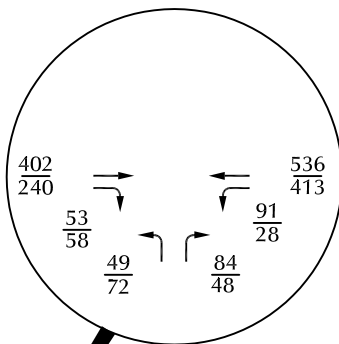
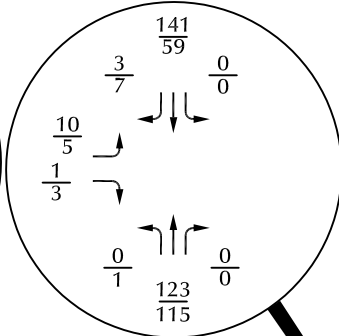
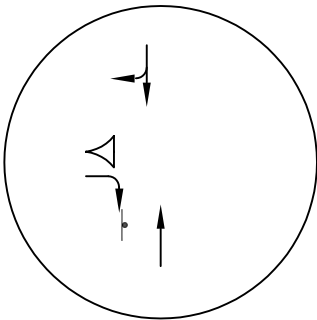
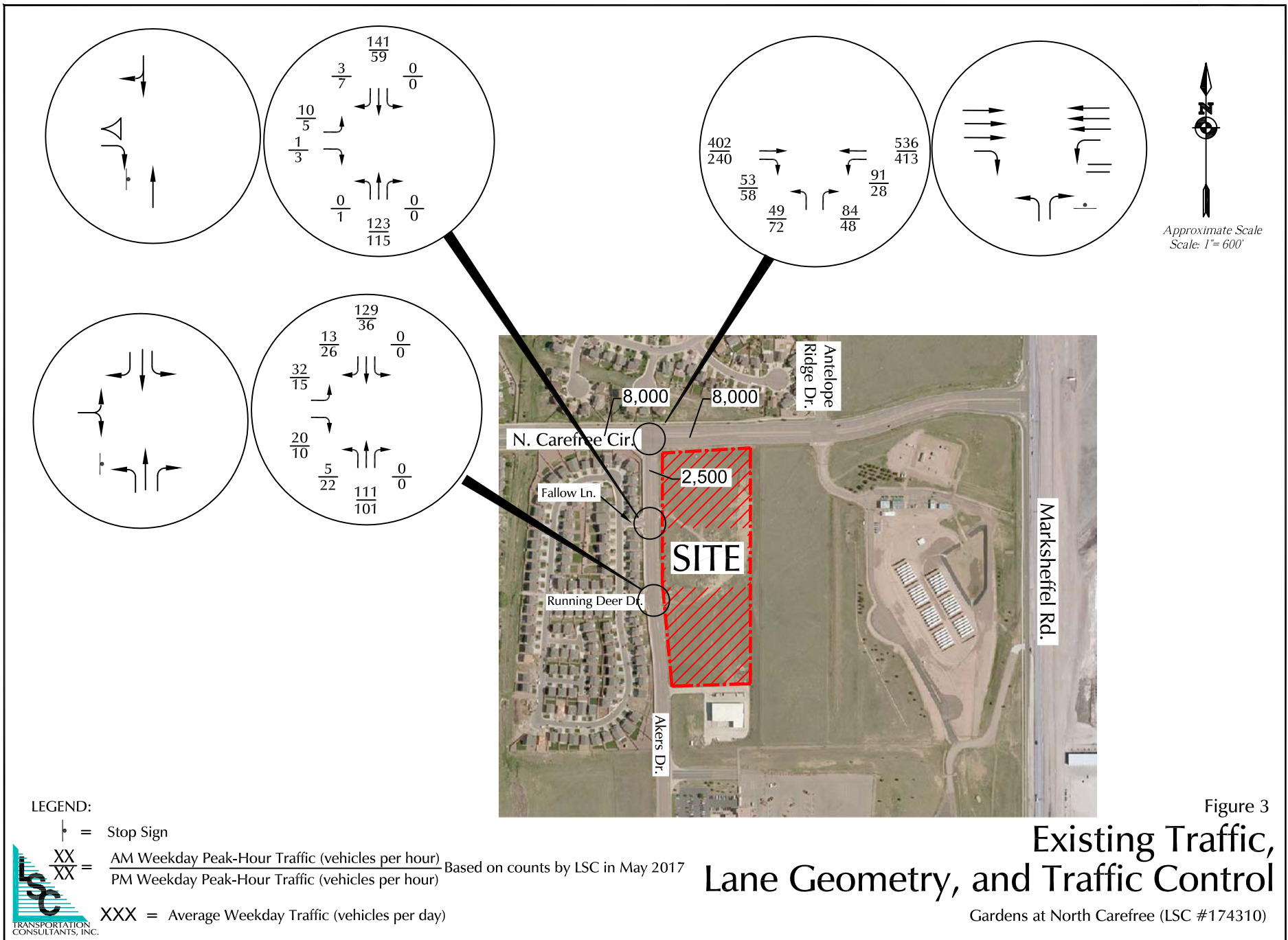
N. Carefree Cir.

Akers Dr.

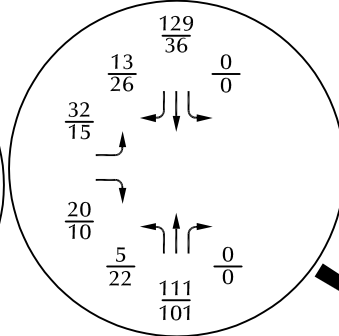
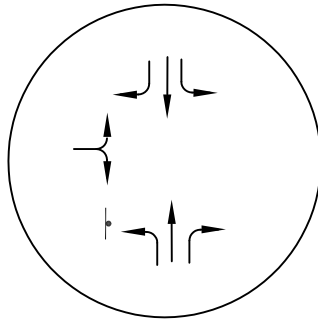
Figure 2  
Site Plan

Gardens at North Carefree (LSC #174310)






Approximate Scale  
 Scale: 1" = 600'





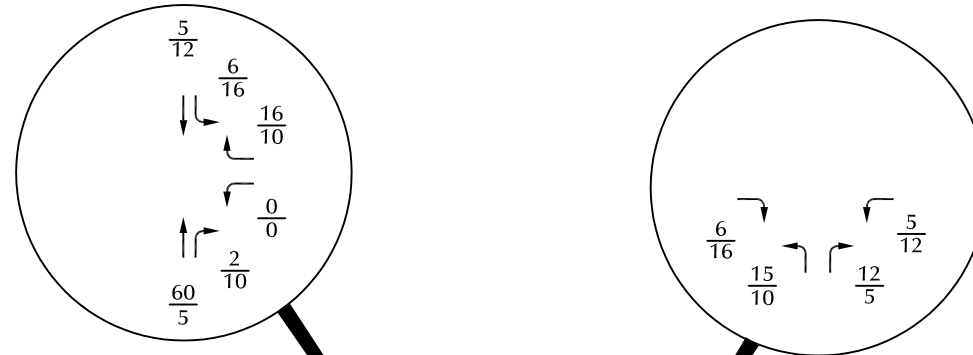
  
 Approximate Scale  
 Scale: 1" = 600'

LEGEND:  
 XX% = AM Weekday Distribution of Site - Generated Traffic  
 XX% = PM Weekday Distribution of Site - Generated Traffic

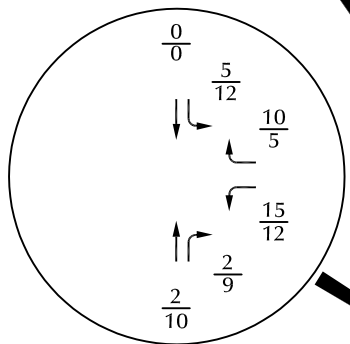


Figure 4  
**Estimated Directional Distribution  
 of Site-Generated Traffic**

Gardens at North Carefree (LSC #174310)



Scale: 1" = 600'



LEGEND:


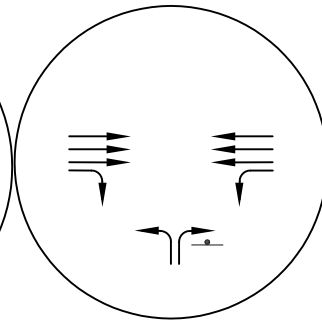
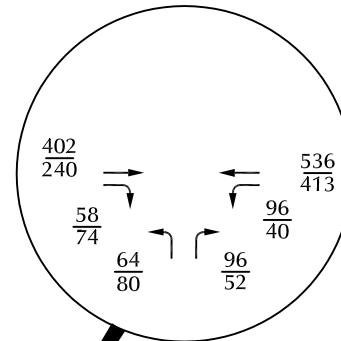
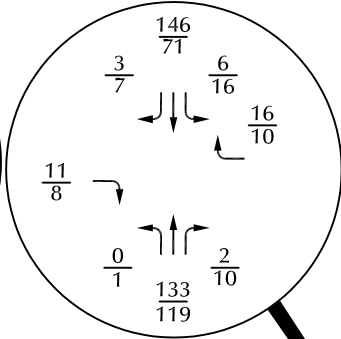
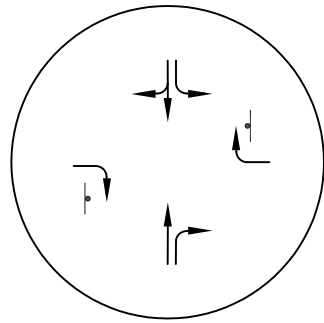
-  = Stop Sign
- $\frac{XX}{XX}$  = AM Weekday Peak-Hour Traffic (vehicles per hour)  
PM Weekday Peak-Hour Traffic (vehicles per hour)
- XXX = Average Weekday Traffic (vehicles per day)

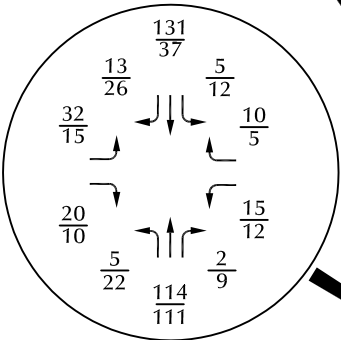
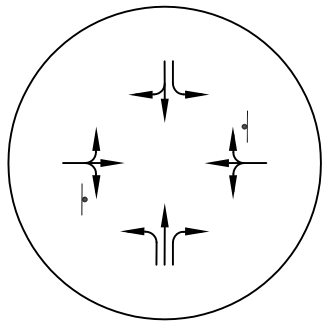


Figure 5  
**Assignment of Site-Generated Traffic**  
 Gardens at North Carefree (LSC #174310)





Approximate Scale  
Scale: 1" = 600'



LEGEND:

⊥ = Stop Sign



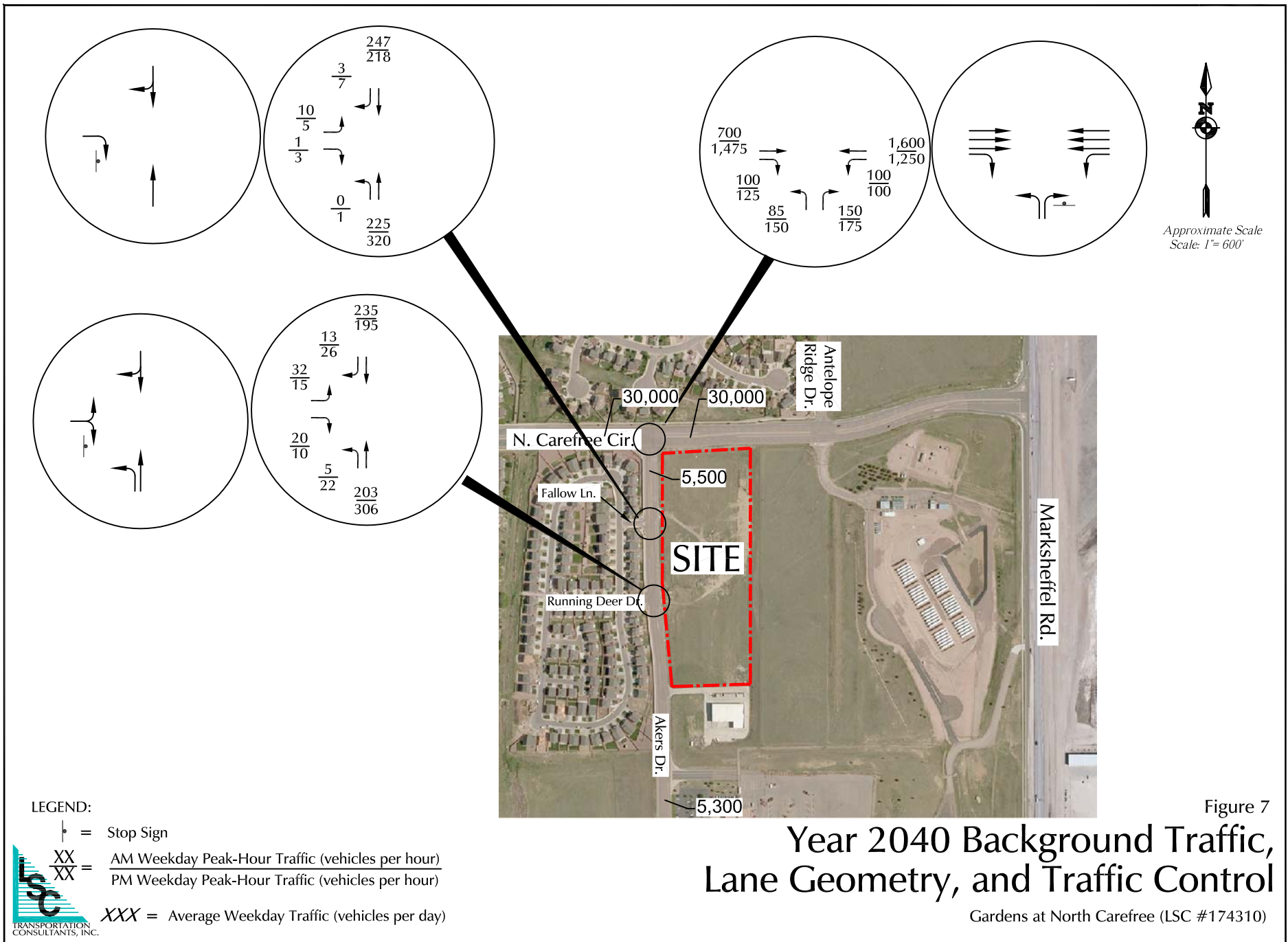
$\frac{XX}{XX}$  = AM Weekday Peak-Hour Traffic (vehicles per hour)  
 PM Weekday Peak-Hour Traffic (vehicles per hour)

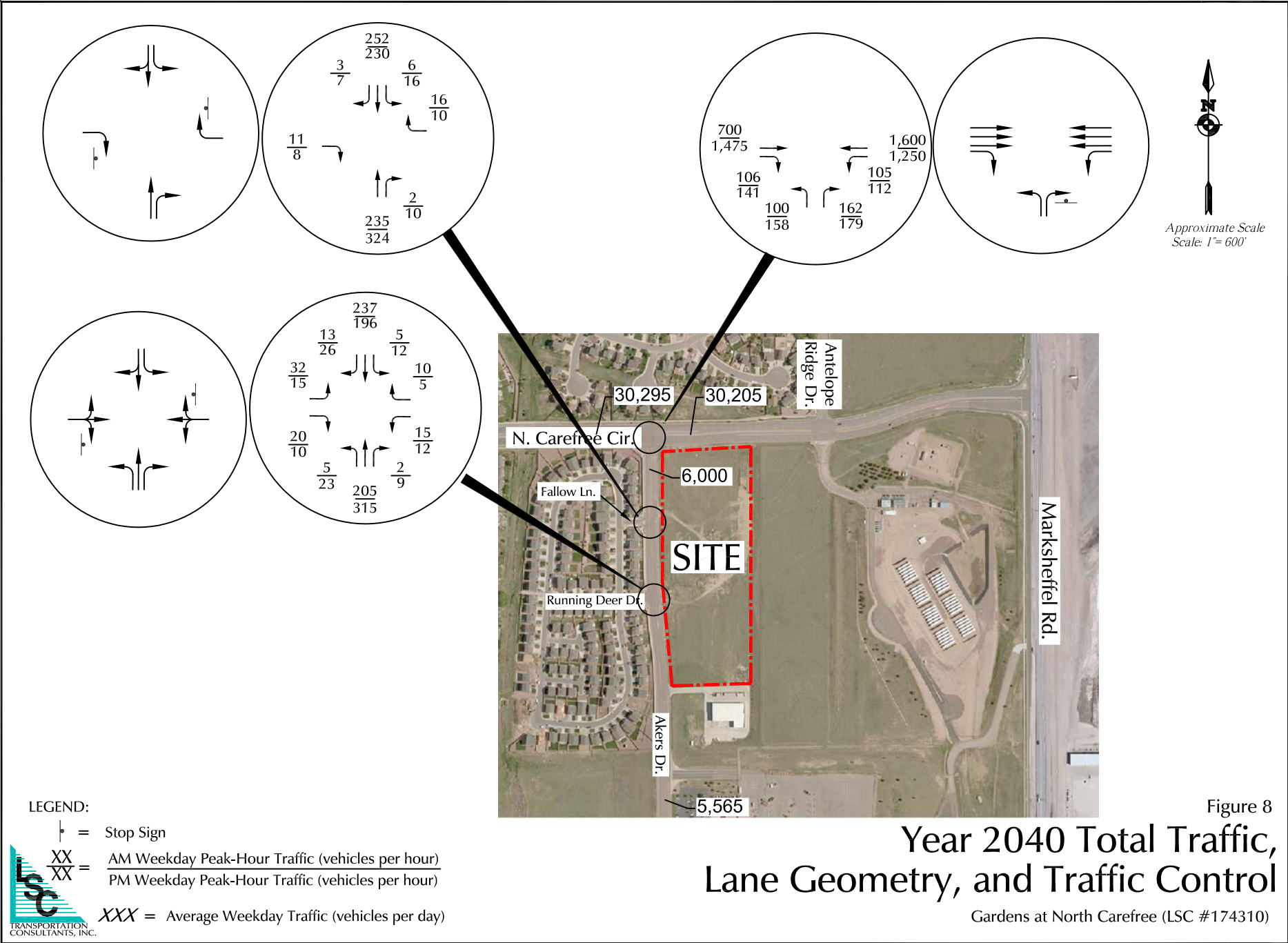
XXX = Average Weekday Traffic (vehicles per day)

# Existing plus Site-Generated Traffic, Lane Geometry, and Traffic Control

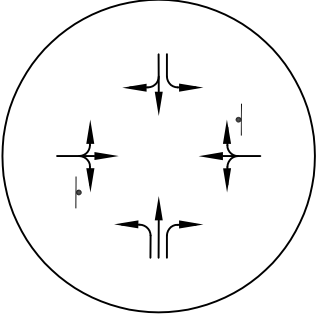
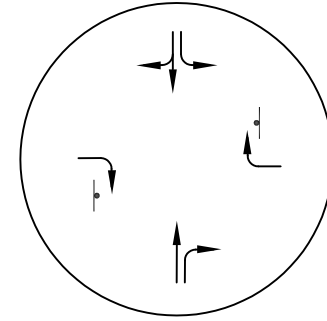
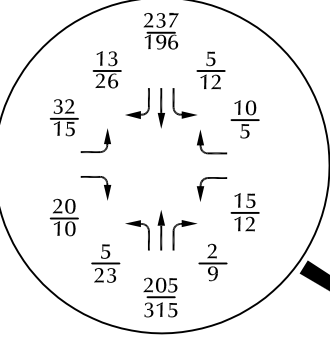
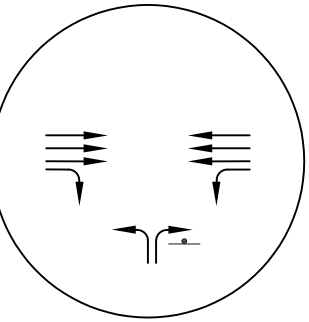
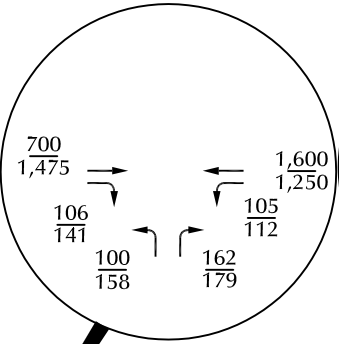
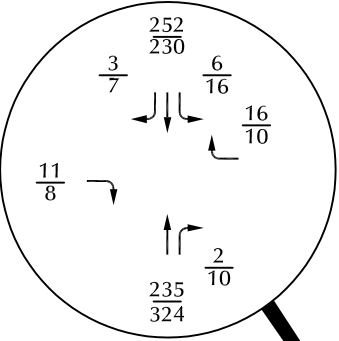
Figure 6

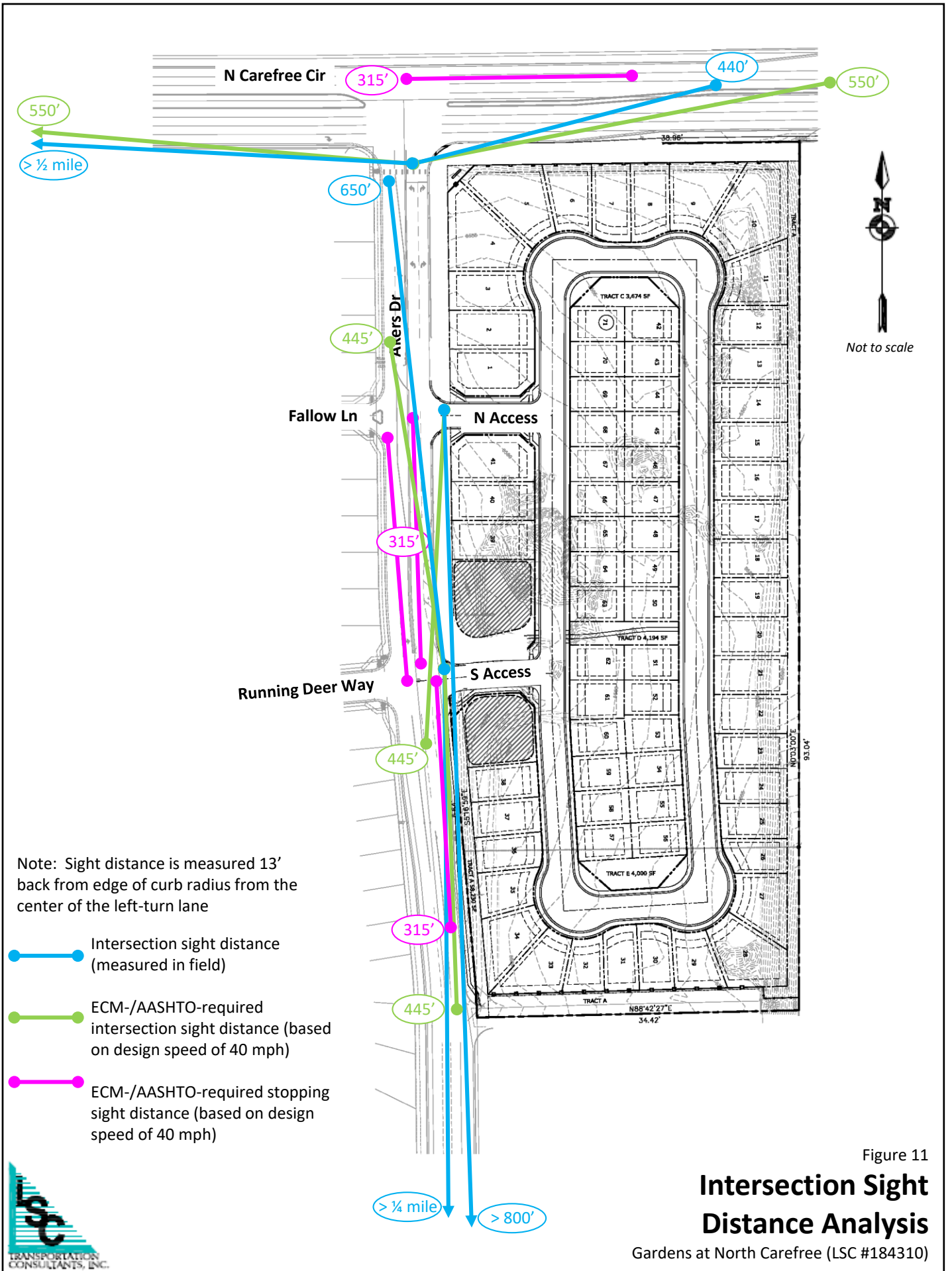
Gardens at North Carefree (LSC #174310)





Approximate Scale  
 Scale: 1" = 600'







Counts by LSC

LSC Transportation Consultants, Inc.

File Name : Akers Dr - Fallow Dr AM  
 Site Code : 00174310  
 Start Date : 05/10/2017  
 Page No : 1

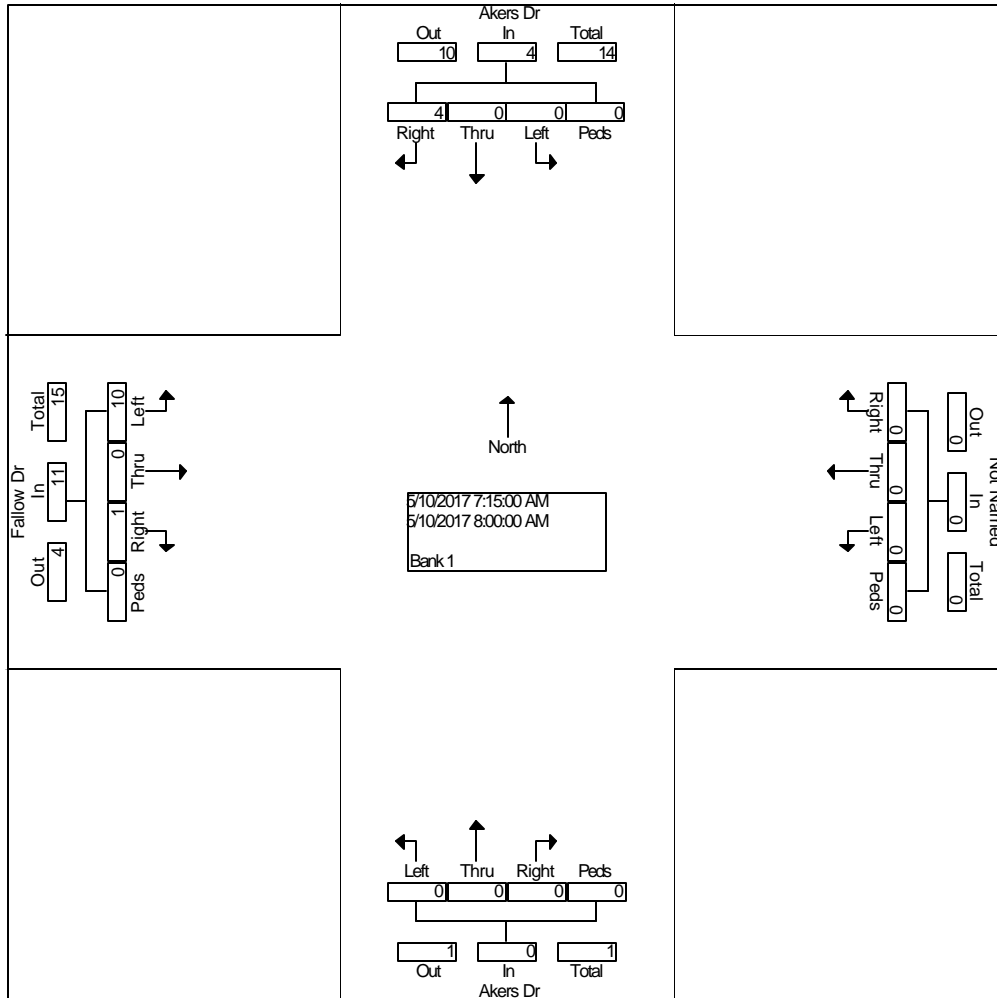
Groups Printed- Bank 1

Start Time	Akers Dr From North				From East				Akers Dr From South				Fallow Dr From West				Int. Total	
	Right	Thru	Left	Peds	Right	Thru	Left	Peds	Right	Thru	Left	Peds	Right	Thru	Left	Peds		
Factor	1.0	1.0	1.0	1.0	1.0	1.0	1.0	1.0	1.0	1.0	1.0	1.0	1.0	1.0	1.0	1.0		
06:30 AM	0	0	0	0	0	0	0	0	0	0	0	0	0	0	0	0	0	0
06:45 AM	0	0	0	0	0	0	0	0	0	0	0	0	4	0	0	0	0	4
Total	0	0	0	0	0	0	0	0	0	0	0	0	4	0	0	0	0	4
07:00 AM	0	0	0	0	0	0	0	0	0	0	0	0	0	0	1	0	0	1
07:15 AM	0	0	0	0	0	0	0	0	0	0	0	0	0	0	4	0	0	4
07:30 AM	1	0	0	0	0	0	0	0	0	0	0	0	1	0	2	0	0	4
07:45 AM	2	0	0	0	0	0	0	0	0	0	0	0	0	0	3	0	0	5
Total	3	0	0	0	0	0	0	0	0	0	0	0	1	0	10	0	0	14
08:00 AM	1	0	0	0	0	0	0	0	0	0	0	0	0	0	1	0	0	2
08:15 AM	0	0	0	0	0	0	0	0	0	0	0	0	1	0	1	0	0	2
Grand Total	4	0	0	0	0	0	0	0	0	0	0	0	6	0	12	0	0	22
Apprch %	100.0	0.0	0.0	0.0	0.0	0.0	0.0	0.0	0.0	0.0	0.0	0.0	33.3	0.0	66.7	0.0	0.0	
Total %	18.2	0.0	0.0	0.0	0.0	0.0	0.0	0.0	0.0	0.0	0.0	0.0	27.3	0.0	54.5	0.0	0.0	

Counts by LSC

File Name : Akers Dr - Fallow Dr AM  
 Site Code : 00174310  
 Start Date : 05/10/2017  
 Page No : 2

Start Time	Akers Dr From North					From East					Akers Dr From South					Fallow Dr From West					Int. Total
	Rig ht	Thr u	Lef t	Pe ds	App. Total	Rig ht	Thr u	Lef t	Pe ds	App. Total	Rig ht	Thr u	Lef t	Pe ds	App. Total	Rig ht	Thr u	Lef t	Pe ds	App. Total	
Peak Hour From 06:30 AM to 08:15 AM - Peak 1 of 1																					
Intersection	07:15 AM																				
Volume	4	0	0	0	4	0	0	0	0	0	0	0	0	0	0	1	0	10	0	11	15
Percent	10	0.0	0.0	0.0		0.0	0.0	0.0	0.0		0.0	0.0	0.0	0.0		9.1	0.0	90.9	0.0		
07:45 Volume	2	0	0	0	2	0	0	0	0	0	0	0	0	0	0	0	0	3	0	3	5
Peak Factor	0.750																				
High Int.	07:45 AM																				
Volume	2	0	0	0	2	6:15:00 AM					6:15:00 AM					07:15 AM					4
Peak Factor	0.50															0.68					8



Counts by LSC

LSC Transportation Consultants, Inc.

File Name : Akers Dr - Fallow Dr PM  
 Site Code : 00174300  
 Start Date : 05/10/2017  
 Page No : 1

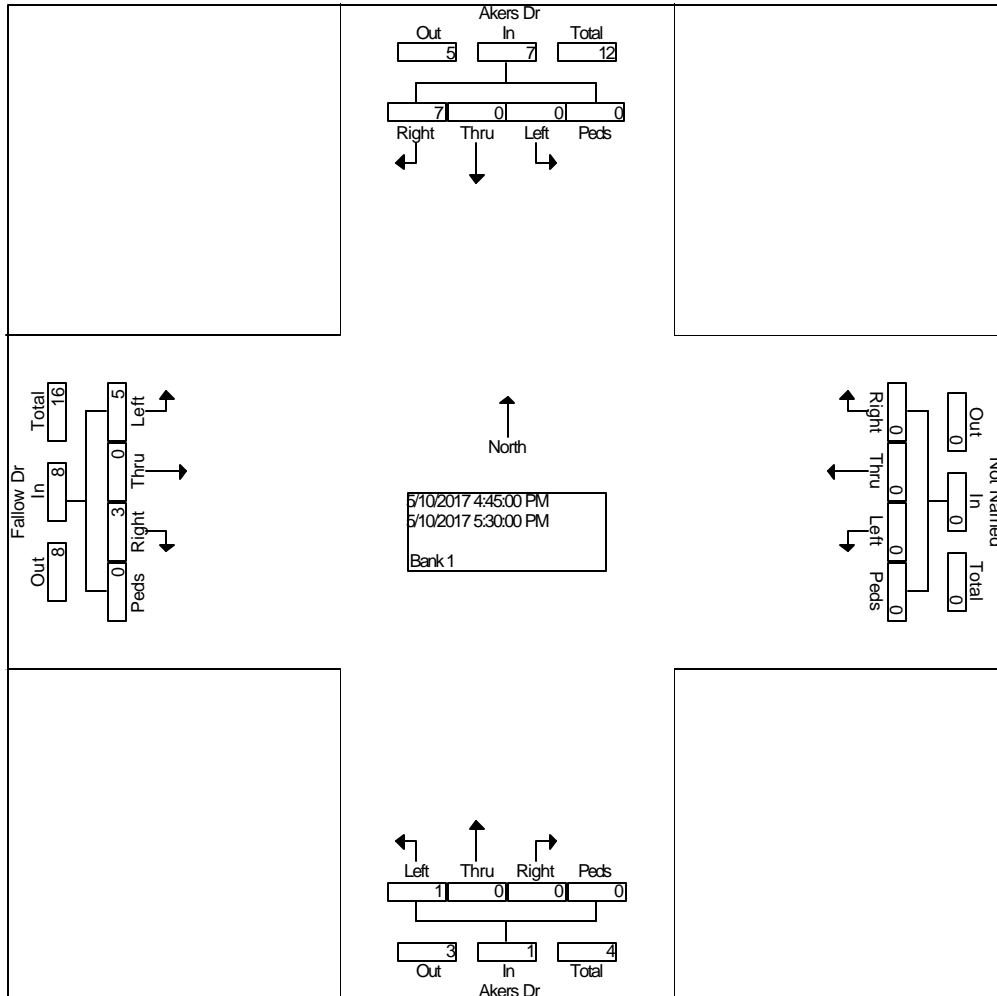
Groups Printed- Bank 1

Start Time	Akers Dr From North				From East				Akers Dr From South				Fallow Dr From West				Int. Total
	Right	Thru	Left	Peds	Right	Thru	Left	Peds	Right	Thru	Left	Peds	Right	Thru	Left	Peds	
Factor	1.0	1.0	1.0	1.0	1.0	1.0	1.0	1.0	1.0	1.0	1.0	1.0	1.0	1.0	1.0	1.0	
04:00 PM	1	0	0	0	0	0	0	0	0	0	2	0	0	0	1	0	4
04:15 PM	1	0	0	0	0	0	0	0	0	0	0	0	0	0	2	0	3
04:30 PM	1	0	0	0	0	0	0	0	0	0	0	0	0	0	1	0	2
04:45 PM	0	0	0	0	0	0	0	0	0	0	0	0	0	0	2	0	2
Total	3	0	0	0	0	0	0	0	0	0	2	0	0	0	6	0	11
05:00 PM	3	0	0	0	0	0	0	0	0	0	0	0	0	0	0	0	3
05:15 PM	2	0	0	0	0	0	0	0	0	0	0	0	1	0	2	0	5
05:30 PM	2	0	0	0	0	0	0	0	0	0	1	0	2	0	1	0	6
05:45 PM	1	0	0	0	0	0	0	0	0	0	0	0	0	0	1	0	2
Total	8	0	0	0	0	0	0	0	0	0	1	0	3	0	4	0	16
Grand Total	11	0	0	0	0	0	0	0	0	0	3	0	3	0	10	0	27
Apprch %	100.0	0.0	0.0	0.0	0.0	0.0	0.0	0.0	0.0	0.0	100.0	0.0	23.1	0.0	76.9	0.0	
Total %	40.7	0.0	0.0	0.0	0.0	0.0	0.0	0.0	0.0	0.0	11.1	0.0	11.1	0.0	37.0	0.0	

Counts by LSC

File Name : Akers Dr - Fallow Dr PM  
 Site Code : 00174300  
 Start Date : 05/10/2017  
 Page No : 2

Start Time	Akers Dr From North					From East					Akers Dr From South					Fallow Dr From West					Int. Total
	Rig ht	Thr u	Lef t	Pe ds	App. Total	Rig ht	Thr u	Lef t	Pe ds	App. Total	Rig ht	Thr u	Lef t	Pe ds	App. Total	Rig ht	Thr u	Lef t	Pe ds	App. Total	
Peak Hour From 04:00 PM to 05:45 PM - Peak 1 of 1																					
Intersection	04:45 PM																				
Volume	7	0	0	0	7	0	0	0	0	0	0	0	1	0	1	3	0	5	0	8	16
Percent	10	0.0	0.0	0.0		0.0	0.0	0.0	0.0		0.0	0.0	10	0.0		37.	0.0	62.	0.0		
	0.0												0.0			5		5			
05:30 Volume	2	0	0	0	2	0	0	0	0	0	0	0	1	0	1	2	0	1	0	3	6
Peak Factor																					
High Int.	05:00 PM					3:45:00 PM					05:30 PM					05:15 PM					0.667
Volume	3	0	0	0	3	0	0	0	0	0	0	0	1	0	1	1	0	2	0	3	3
Peak Factor	0.58										0.25					0.66					7
	3										0					7					





Counts by LSC

LSC Transportation Consultants, Inc.

File Name : Akers Dr - N Carefree Cir AM  
 Site Code : 00174310  
 Start Date : 05/10/2017  
 Page No : 1

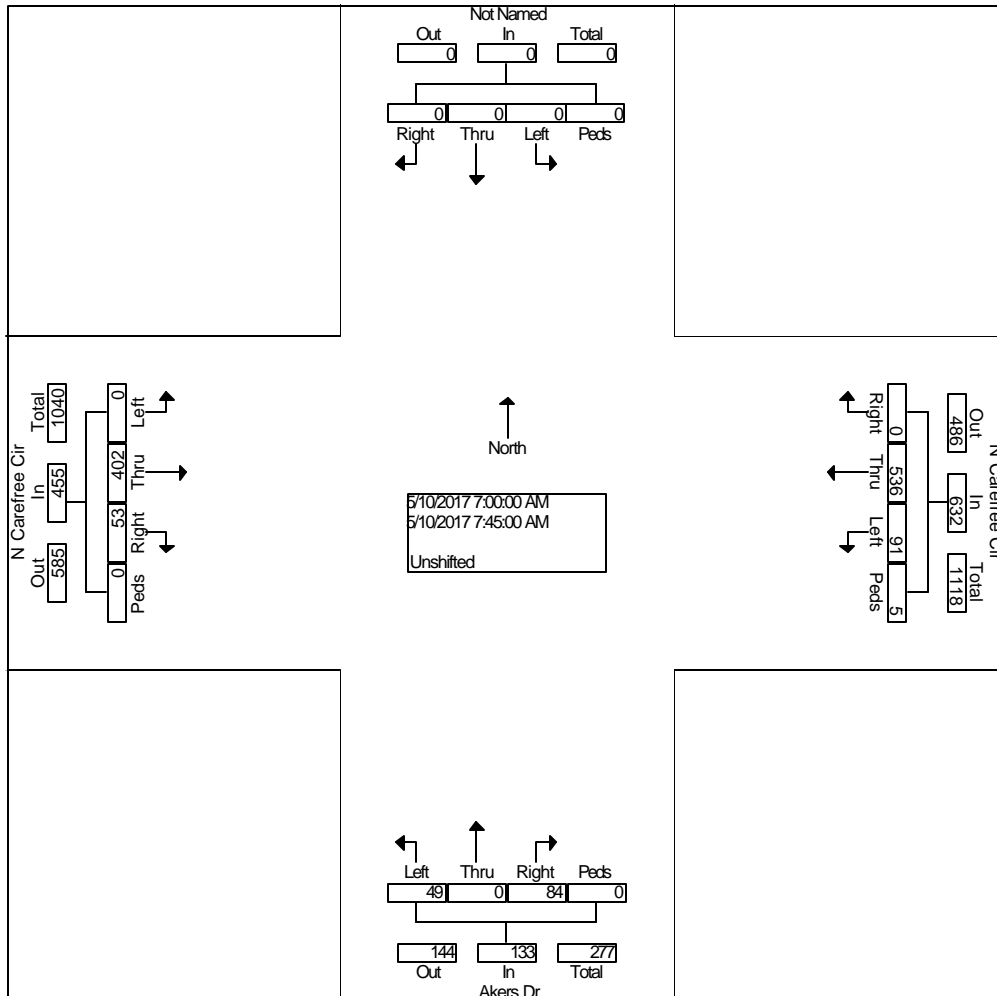
Groups Printed- Unshifted

Start Time	From North				N Carefree Cir From East				Akers Dr From South				N Carefree Cir From West				Int. Total
	Right	Thru	Left	Peds	Right	Thru	Left	Peds	Right	Thru	Left	Peds	Right	Thru	Left	Peds	
Factor	1.0	1.0	1.0	1.0	1.0	1.0	1.0	1.0	1.0	1.0	1.0	1.0	1.0	1.0	1.0	1.0	
06:30 AM	0	0	0	0	0	36	1	0	4	0	7	0	9	48	0	0	105
06:45 AM	0	0	0	0	0	43	2	0	5	0	8	0	12	51	0	0	121
Total	0	0	0	0	0	79	3	0	9	0	15	0	21	99	0	0	226
07:00 AM	0	0	0	0	0	67	5	0	7	0	9	0	17	72	0	0	177
07:15 AM	0	0	0	0	0	102	18	0	21	0	11	0	10	122	0	0	284
07:30 AM	0	0	0	0	0	176	44	5	39	0	16	0	13	113	0	0	406
07:45 AM	0	0	0	0	0	191	24	0	17	0	13	0	13	95	0	0	353
Total	0	0	0	0	0	536	91	5	84	0	49	0	53	402	0	0	1220
08:00 AM	0	0	0	0	0	64	14	0	7	0	12	0	11	48	0	1	157
08:15 AM	0	0	0	0	0	57	2	0	3	0	12	0	10	39	0	0	123
Grand Total	0	0	0	0	0	736	110	5	103	0	88	0	95	588	0	1	1726
Apprch %	0.0	0.0	0.0	0.0	0.0	86.5	12.9	0.6	53.9	0.0	46.1	0.0	13.9	86.0	0.0	0.1	
Total %	0.0	0.0	0.0	0.0	0.0	42.6	6.4	0.3	6.0	0.0	5.1	0.0	5.5	34.1	0.0	0.1	

Counts by LSC

File Name : Akers Dr - N Carefree Cir AM  
 Site Code : 00174310  
 Start Date : 05/10/2017  
 Page No : 2

Start Time	From North					N Carefree Cir From East					Akers Dr From South					N Carefree Cir From West					Int. Total				
	Rig ht	Thr u	Lef t	Pe ds	App. Total	Rig ht	Thr u	Lef t	Pe ds	App. Total	Rig ht	Thr u	Lef t	Pe ds	App. Total	Rig ht	Thr u	Lef t	Pe ds	App. Total					
Peak Hour From 06:30 AM to 08:15 AM - Peak 1 of 1																									
Intersection	07:00 AM																								
Volume	0	0	0	0	0	0	53	91	5	632	84	0	49	0	133	53	40	0	0	455	1220				
Percent	0.0	0.0	0.0	0.0		0.0	84.	14.	0.8		63.	0.0	36.	0.0		11.	88.	0.0	0.0						
							8	4			2		8			6	4								
07:30 Volume	0	0	0	0	0	0	17	44	5	225	39	0	16	0	55	13	11	0	0	126	406				
Peak Factor																									
High Int.	6:15:00 AM					07:30 AM					07:30 AM					07:15 AM									
Volume	0	0	0	0	0	0	17	44	5	225	39	0	16	0	55	10	12	0	0	132					
Peak Factor											0.70					0.60					0.86				
											2					5					2				



Counts by LSC

LSC Transportation Consultants, Inc.

File Name : Akers Dr - N Carefree Cir PM  
 Site Code : 00174300  
 Start Date : 05/10/2017  
 Page No : 1

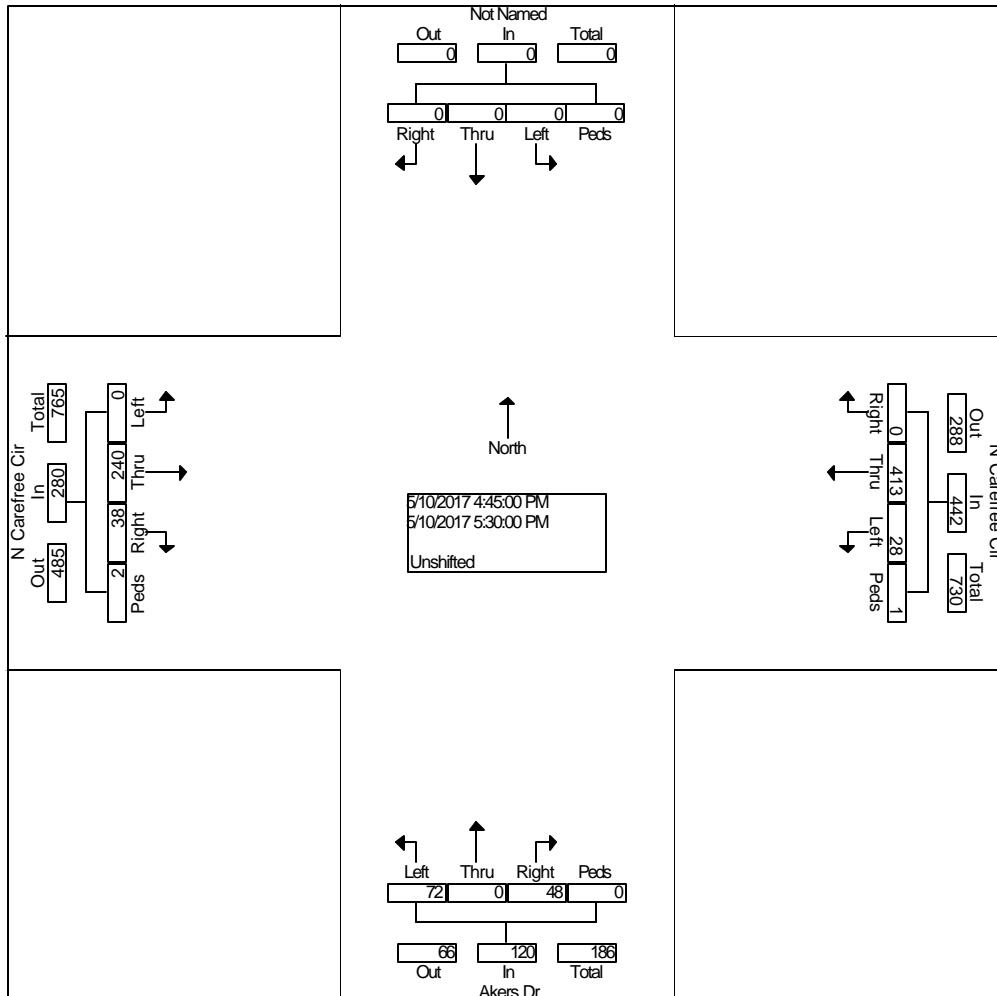
Groups Printed- Unshifted

Start Time	From North				N Carefree Cir From East				Akers Dr From South				N Carefree Cir From West				Int. Total
	Right	Thru	Left	Peds	Right	Thru	Left	Peds	Right	Thru	Left	Peds	Right	Thru	Left	Peds	
Factor	1.0	1.0	1.0	1.0	1.0	1.0	1.0	1.0	1.0	1.0	1.0	1.0	1.0	1.0	1.0	1.0	
04:00 PM	0	0	0	0	0	80	10	0	11	0	21	0	16	76	0	0	214
04:15 PM	0	0	0	0	0	91	6	0	9	0	18	0	14	66	0	1	205
04:30 PM	0	0	0	0	0	83	9	0	5	0	8	0	11	61	0	1	178
04:45 PM	0	0	0	0	0	87	10	1	10	0	15	0	5	57	0	0	185
Total	0	0	0	0	0	341	35	1	35	0	62	0	46	260	0	2	782
05:00 PM	0	0	0	0	0	135	3	0	21	0	29	0	11	65	0	1	265
05:15 PM	0	0	0	0	0	115	7	0	9	0	17	0	12	50	0	1	211
05:30 PM	0	0	0	0	0	76	8	0	8	0	11	0	10	68	0	0	181
05:45 PM	0	0	0	0	0	69	6	0	6	0	9	0	8	61	0	0	159
Total	0	0	0	0	0	395	24	0	44	0	66	0	41	244	0	2	816
Grand Total	0	0	0	0	0	736	59	1	79	0	128	0	87	504	0	4	1598
Apprch %	0.0	0.0	0.0	0.0	0.0	92.5	7.4	0.1	38.2	0.0	61.8	0.0	14.6	84.7	0.0	0.7	
Total %	0.0	0.0	0.0	0.0	0.0	46.1	3.7	0.1	4.9	0.0	8.0	0.0	5.4	31.5	0.0	0.3	

Counts by LSC

File Name : Akers Dr - N Carefree Cir PM  
 Site Code : 00174300  
 Start Date : 05/10/2017  
 Page No : 2

Start Time	From North					N Carefree Cir From East					Akers Dr From South					N Carefree Cir From West					Int. Total				
	Rig ht	Thr u	Lef t	Pe ds	App. Total	Rig ht	Thr u	Lef t	Pe ds	App. Total	Rig ht	Thr u	Lef t	Pe ds	App. Total	Rig ht	Thr u	Lef t	Pe ds	App. Total					
Peak Hour From 04:00 PM to 05:45 PM - Peak 1 of 1																									
Intersection	04:45 PM																								
Volume	0	0	0	0	0	0	41	28	1	442	48	0	72	0	120	38	24	0	2	280	842				
Percent	0.0	0.0	0.0	0.0		0.0	93.	6.3	0.2		40.	0.0	60.	0.0		13.	85.	0.0	0.7						
05:00 Volume	0	0	0	0	0	0	13	3	0	138	21	0	29	0	50	11	65	0	1	77	265				
Peak Factor																					0.794				
High Int.	3:45:00 PM					05:00 PM					05:00 PM					05:30 PM									
Volume	0	0	0	0	0	0	13	3	0	138	21	0	29	0	50	10	68	0	0	78					
Peak Factor											0.80					0.60					0.89				
											1					0					7				



Counts by LSC

LSC Transportation Consultants, Inc.

File Name : Akers Dr - Running Deer Wy AM  
 Site Code : 00174310  
 Start Date : 05/10/2017  
 Page No : 1

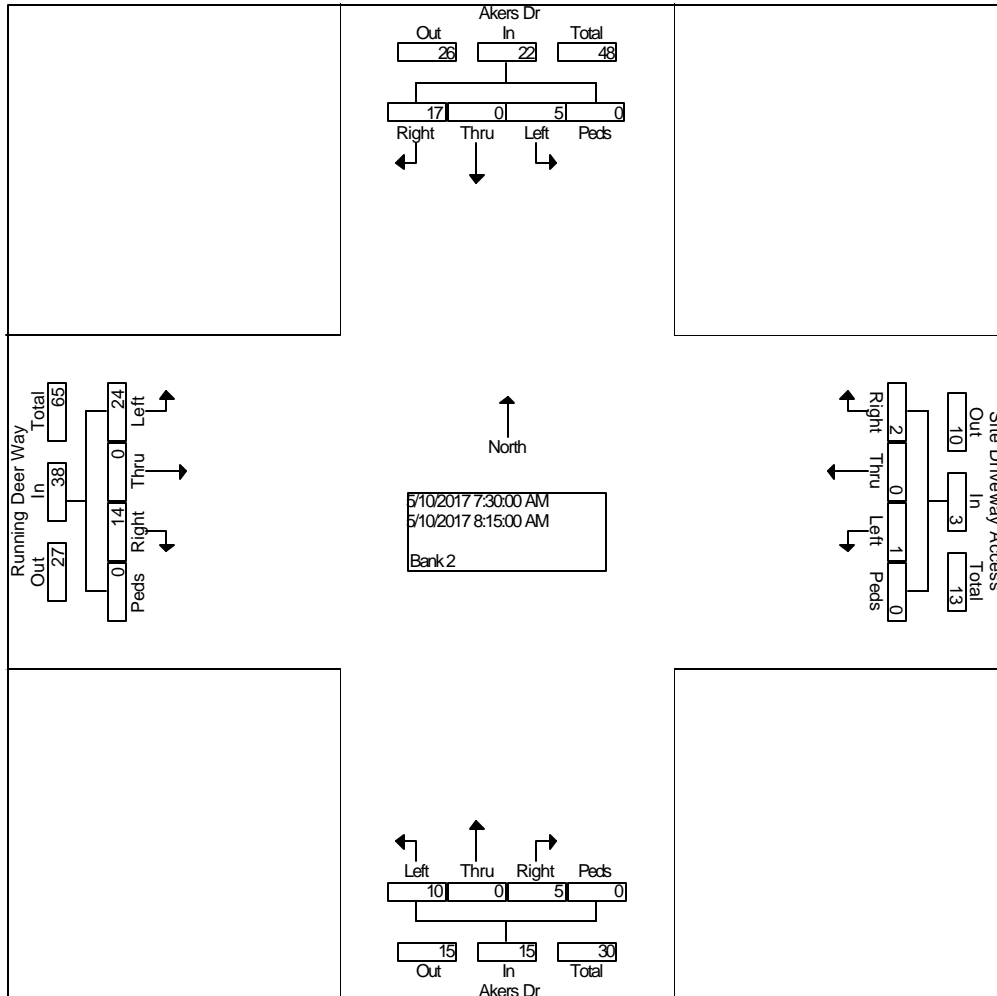
Groups Printed- Bank 2

Start Time	Akers Dr From North				Site Driveway Access From East				Akers Dr From South				Running Deer Way From West				Int. Total
	Right	Thru	Left	Peds	Right	Thru	Left	Peds	Right	Thru	Left	Peds	Right	Thru	Left	Peds	
Factor	1.0	1.0	1.0	1.0	1.0	1.0	1.0	1.0	1.0	1.0	1.0	1.0	1.0	1.0	1.0	1.0	
06:30 AM	0	0	0	0	0	0	0	0	0	0	0	0	5	0	5	0	10
06:45 AM	0	0	0	0	0	0	0	0	1	0	1	0	6	0	4	0	12
Total	0	0	0	0	0	0	0	0	1	0	1	0	11	0	9	0	22
07:00 AM	0	0	0	0	0	0	1	0	0	0	1	0	7	0	7	0	16
07:15 AM	1	0	0	0	0	0	0	0	0	0	0	0	5	0	6	0	12
07:30 AM	5	0	1	0	0	0	0	0	1	0	2	0	8	0	13	0	30
07:45 AM	7	0	1	0	0	0	1	0	1	0	2	0	0	0	6	0	18
Total	13	0	2	0	0	0	2	0	2	0	5	0	20	0	32	0	76
08:00 AM	1	0	1	0	0	0	0	0	1	0	4	0	5	0	2	0	14
08:15 AM	4	0	2	0	2	0	0	0	2	0	2	0	1	0	3	0	16
Grand Total	18	0	5	0	2	0	2	0	6	0	12	0	37	0	46	0	128
Apprch %	78.3	0.0	21.7	0.0	50.0	0.0	50.0	0.0	33.3	0.0	66.7	0.0	44.6	0.0	55.4	0.0	
Total %	14.1	0.0	3.9	0.0	1.6	0.0	1.6	0.0	4.7	0.0	9.4	0.0	28.9	0.0	35.9	0.0	

Counts by LSC

File Name : Akers Dr - Running Deer Wy AM  
 Site Code : 00174310  
 Start Date : 05/10/2017  
 Page No : 2

Start Time	Akers Dr From North					Site Driveway Access From East					Akers Dr From South					Running Deer Way From West					Int. Total
	Rig ht	Thru	Lef t	Pe ds	App. Total	Rig ht	Thru	Lef t	Pe ds	App. Total	Rig ht	Thru	Lef t	Pe ds	App. Total	Rig ht	Thru	Lef t	Pe ds	App. Total	
Peak Hour From 06:30 AM to 08:15 AM - Peak 1 of 1																					
Intersection	07:30 AM																				
Volume	17	0	5	0	22	2	0	1	0	3	5	0	10	0	15	14	0	24	0	38	78
Percent	77.3	0.0	22.7	0.0		66.7	0.0	33.3	0.0		33.3	0.0	66.7	0.0		36.8	0.0	63.2	0.0		
07:30 Volume	5	0	1	0	6	0	0	0	0	0	1	0	2	0	3	8	0	13	0	21	30
Peak Factor																					
High Int.	07:45 AM																				
Volume	7	0	1	0	8	2	0	0	0	2	1	0	4	0	5	8	0	13	0	21	0.650
Peak Factor					0.68					0.37					0.75					0.45	2



Counts by LSC

LSC Transportation Consultants, Inc.

File Name : Akers Dr - Running Deer Wy PM  
 Site Code : 00174300  
 Start Date : 05/10/2017  
 Page No : 1

Groups Printed- Bank 2

Start Time	Akers Dr From North				Site Driveway Access From East				Akers Dr From South				Running Deer Way From West				Int. Total
	Right	Thru	Left	Peds	Right	Thru	Left	Peds	Right	Thru	Left	Peds	Right	Thru	Left	Peds	
Factor	1.0	1.0	1.0	1.0	1.0	1.0	1.0	1.0	1.0	1.0	1.0	1.0	1.0	1.0	1.0	1.0	
04:00 PM	6	0	1	0	0	0	0	0	0	0	9	0	4	0	8	0	28
04:15 PM	4	0	4	0	1	0	0	0	1	0	7	0	4	0	8	0	29
04:30 PM	3	0	1	0	0	0	0	0	0	0	5	0	0	0	3	0	12
04:45 PM	7	0	1	0	0	0	0	0	0	0	5	0	4	0	6	0	23
Total	20	0	7	0	1	0	0	0	1	0	26	0	12	0	25	0	92
05:00 PM	5	0	0	0	0	0	0	0	1	0	5	0	2	0	3	0	16
05:15 PM	8	0	0	0	1	0	0	0	1	0	7	0	3	0	4	0	24
05:30 PM	6	0	1	0	3	0	0	0	0	0	5	0	1	0	2	0	18
05:45 PM	5	0	1	0	1	0	0	0	1	0	3	0	1	0	2	0	14
Total	24	0	2	0	5	0	0	0	3	0	20	0	7	0	11	0	72
Grand Total	44	0	9	0	6	0	0	0	4	0	46	0	19	0	36	0	164
Apprch %	83.0	0.0	17.0	0.0	100.0	0.0	0.0	0.0	8.0	0.0	92.0	0.0	34.5	0.0	65.5	0.0	
Total %	26.8	0.0	5.5	0.0	3.7	0.0	0.0	0.0	2.4	0.0	28.0	0.0	11.6	0.0	22.0	0.0	

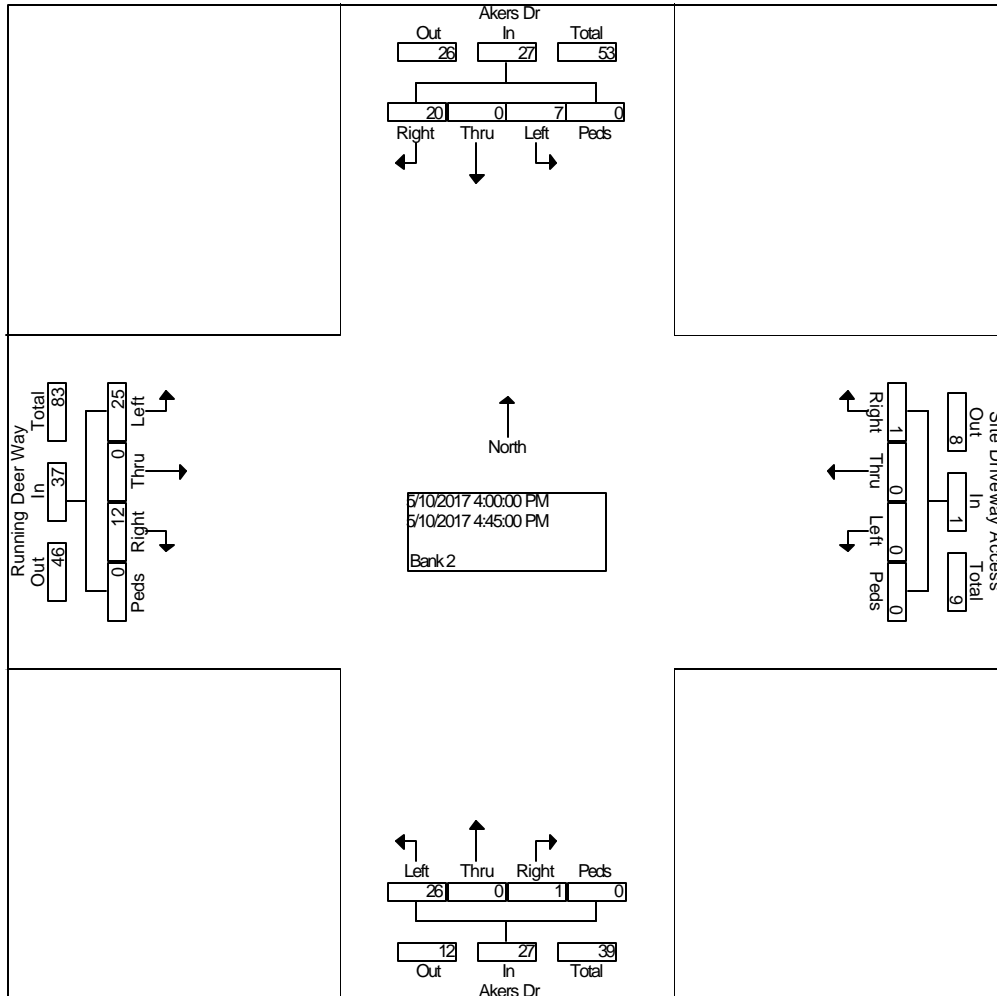
Counts by LSC

File Name : Akers Dr - Running Deer Wy PM  
 Site Code : 00174300  
 Start Date : 05/10/2017  
 Page No : 2

Start Time	Akers Dr From North					Site Driveway Access From East					Akers Dr From South					Running Deer Way From West					Int. Total
	Rig ht	Thr u	Lef t	Pe ds	App. Total	Rig ht	Thr u	Lef t	Pe ds	App. Total	Rig ht	Thr u	Lef t	Pe ds	App. Total	Rig ht	Thr u	Lef t	Pe ds	App. Total	

Peak Hour From 04:00 PM to 05:45 PM - Peak 1 of 1

Intersection	04:00 PM																				
Volume	20	0	7	0	27	1	0	0	0	1	1	0	26	0	27	12	0	25	0	37	92
Percent	74.1	0.0	25.9	0.0		10.0	0.0	0.0	0.0		3.7	0.0	96.3	0.0		32.4	0.0	67.6	0.0		
04:15 Volume	4	0	4	0	8	1	0	0	0	1	1	0	7	0	8	4	0	8	0	12	29
Peak Factor	0.793																				
High Int. Volume	04:15 PM					04:15 PM					04:00 PM					04:00 PM					
Peak Factor	0.84					0.25					0.75					0.77					1





Counts by LSC

LSC Transportation Consultants, Inc.

File Name : Antelope Ridge Dr - N Carefree Cir AM  
 Site Code : 00174310  
 Start Date : 05/09/2017  
 Page No : 1

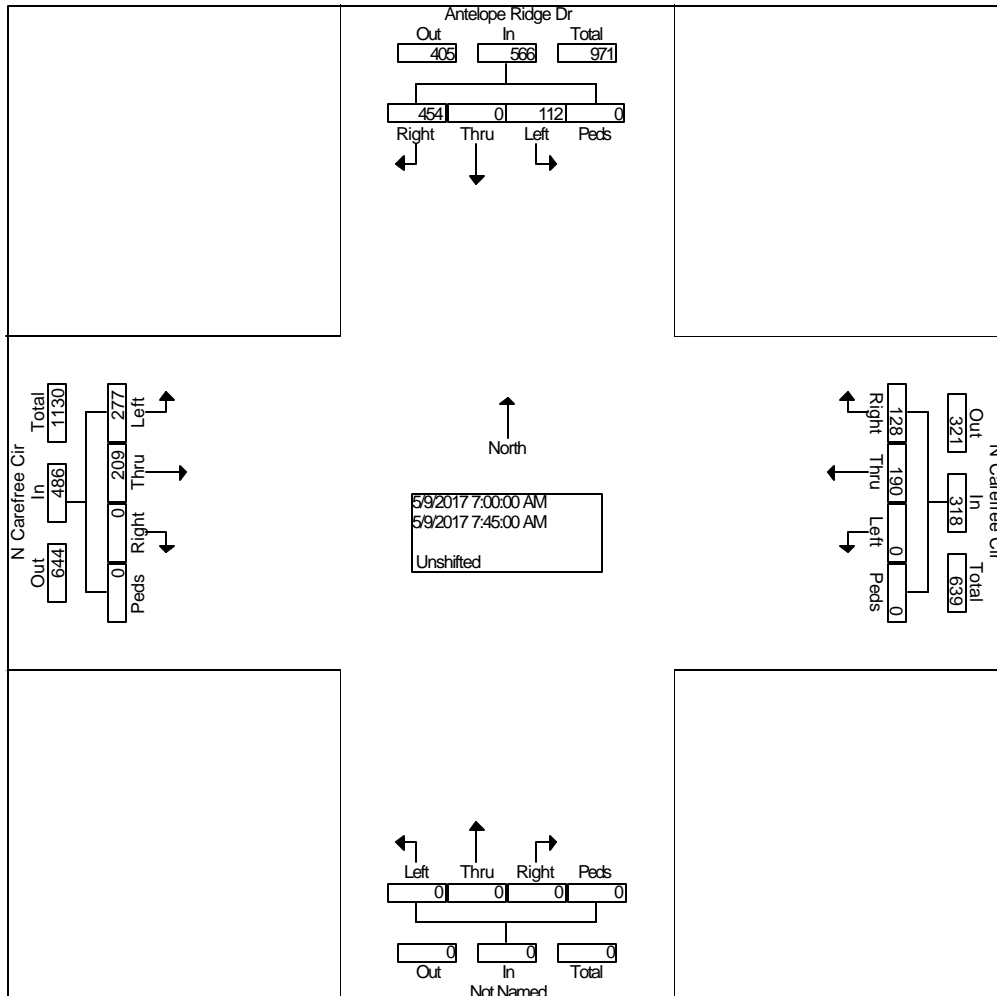
Groups Printed- Unshifted

Start Time	Antelope Ridge Dr From North				N Carefree Cir From East				From South				N Carefree Cir From West				Int. Total
	Right	Thru	Left	Peds	Right	Thru	Left	Peds	Right	Thru	Left	Peds	Right	Thru	Left	Peds	
Factor	1.0	1.0	1.0	1.0	1.0	1.0	1.0	1.0	1.0	1.0	1.0	1.0	1.0	1.0	1.0	1.0	
06:30 AM	16	0	18	0	2	19	0	0	0	0	0	0	0	49	12	0	116
06:45 AM	18	0	26	0	2	22	0	0	0	0	0	0	0	56	14	0	138
Total	34	0	44	0	4	41	0	0	0	0	0	0	0	105	26	0	254
07:00 AM	40	0	17	0	13	53	0	0	0	0	0	0	0	60	36	0	219
07:15 AM	72	0	24	0	23	50	0	0	0	0	0	0	0	54	78	0	301
07:30 AM	161	0	24	0	54	47	0	0	0	0	0	0	0	53	102	0	441
07:45 AM	181	0	47	0	38	40	0	0	0	0	0	0	0	42	61	0	409
Total	454	0	112	0	128	190	0	0	0	0	0	0	0	209	277	0	1370
08:00 AM	20	0	19	0	6	47	0	0	0	0	0	0	0	32	15	0	139
08:15 AM	10	0	11	0	2	31	0	0	0	0	0	0	0	33	12	0	99
Grand Total	518	0	186	0	140	309	0	0	0	0	0	0	0	379	330	0	1862
Apprch %	73.6	0.0	26.4	0.0	31.2	68.8	0.0	0.0	0.0	0.0	0.0	0.0	0.0	53.5	46.5	0.0	
Total %	27.8	0.0	10.0	0.0	7.5	16.6	0.0	0.0	0.0	0.0	0.0	0.0	0.0	20.4	17.7	0.0	

Counts by LSC

File Name : Antelope Ridge Dr - N Carefree Cir AM  
 Site Code : 00174310  
 Start Date : 05/09/2017  
 Page No : 2

Start Time	Antelope Ridge Dr From North					N Carefree Cir From East					From South					N Carefree Cir From West					Int. Total
	Rig ht	Thr u	Lef t	Pe ds	App. Total	Rig ht	Thr u	Lef t	Pe ds	App. Total	Rig ht	Thr u	Lef t	Pe ds	App. Total	Rig ht	Thr u	Lef t	Pe ds	App. Total	
Peak Hour From 06:30 AM to 08:15 AM - Peak 1 of 1																					
Intersection	07:00 AM																				
Volume	45	0	11	0	566	12	19	0	0	318	0	0	0	0	0	0	20	27	0	486	1370
Percent	80.2	0.0	19.8	0.0		40.3	59.7	0.0	0.0		0.0	0.0	0.0	0.0		0.0	43.0	57.0	0.0		
07:30 Volume	16	0	24	0	185	54	47	0	0	101	0	0	0	0	0	0	53	10	0	155	441
Peak Factor	0.777																				
High Int.	07:45 AM					07:30 AM					6:15:00 AM					07:30 AM					
Volume	18	0	47	0	228	54	47	0	0	101	0	0	0	0	0	0	53	10	0	155	
Peak Factor	0.62					0.78					0.78					0.78					
	1					7					7					4					



Counts by LSC

LSC Transportation Consultants, Inc.

File Name : Antelope Ridge Dr - N Carefree PM  
 Site Code : 00174310  
 Start Date : 05/04/2017  
 Page No : 1

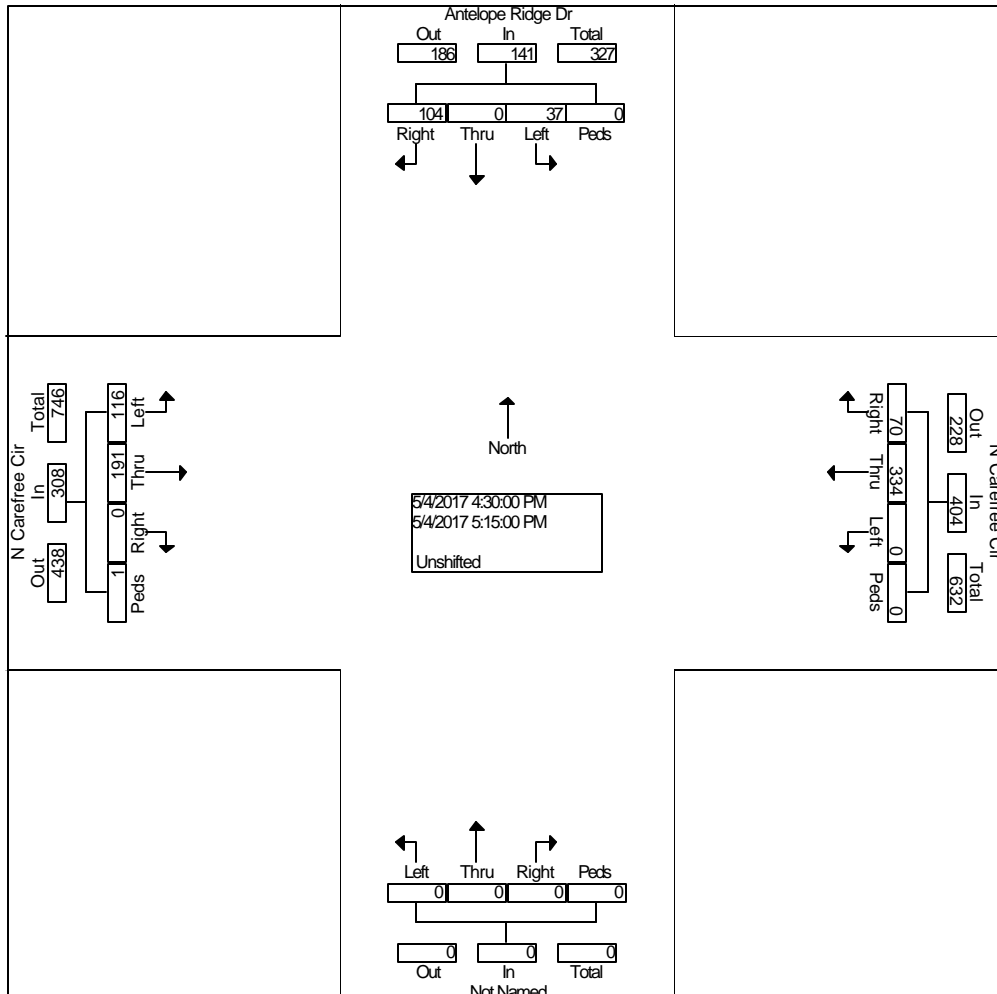
Groups Printed- Unshifted

Start Time	Antelope Ridge Dr From North				N Carefree Cir From East				From South				N Carefree Cir From West				Int. Total
	Right	Thru	Left	Peds	Right	Thru	Left	Peds	Right	Thru	Left	Peds	Right	Thru	Left	Peds	
Factor	1.0	1.0	1.0	1.0	1.0	1.0	1.0	1.0	1.0	1.0	1.0	1.0	1.0	1.0	1.0	1.0	
04:00 PM	26	0	5	0	10	64	0	0	1	0	1	0	0	56	32	0	195
04:15 PM	31	0	3	0	15	81	0	0	0	0	0	0	0	34	36	0	200
04:30 PM	32	0	11	0	12	77	0	0	0	0	0	0	0	51	33	0	216
04:45 PM	25	0	7	0	25	79	0	0	0	0	0	0	0	44	33	0	213
Total	114	0	26	0	62	301	0	0	1	0	1	0	0	185	134	0	824
05:00 PM	24	0	10	0	18	88	0	0	0	0	0	0	0	41	25	0	206
05:15 PM	23	0	9	0	15	90	0	0	0	0	0	0	0	55	25	1	218
05:30 PM	10	0	7	0	24	54	0	0	0	0	0	0	0	62	31	0	188
05:45 PM	13	0	6	0	22	51	0	0	0	0	0	0	0	55	30	0	177
Total	70	0	32	0	79	283	0	0	0	0	0	0	0	213	111	1	789
Grand Total	184	0	58	0	141	584	0	0	1	0	1	0	0	398	245	1	1613
Apprch %	76.0	0.0	24.0	0.0	19.4	80.6	0.0	0.0	50.0	0.0	50.0	0.0	0.0	61.8	38.0	0.2	
Total %	11.4	0.0	3.6	0.0	8.7	36.2	0.0	0.0	0.1	0.0	0.1	0.0	0.0	24.7	15.2	0.1	

Counts by LSC

File Name : Antelope Ridge Dr - N Carefree PM  
 Site Code : 00174310  
 Start Date : 05/04/2017  
 Page No : 2

Start Time	Antelope Ridge Dr From North					N Carefree Cir From East					From South					N Carefree Cir From West					Int. Total
	Rig ht	Thr u	Lef t	Pe ds	App. Total	Rig ht	Thr u	Lef t	Pe ds	App. Total	Rig ht	Thr u	Lef t	Pe ds	App. Total	Rig ht	Thr u	Lef t	Pe ds	App. Total	
Peak Hour From 04:00 PM to 05:45 PM - Peak 1 of 1																					
Intersection	04:30 PM																				
Volume	10	0	37	0	141	70	33	0	0	404	0	0	0	0	0	0	19	11	1	308	853
Percent	73.8	0.0	26.2	0.0		17.3	82.7	0.0	0.0		0.0	0.0	0.0	0.0		0.0	62.0	37.7	0.3		
05:15 Volume	23	0	9	0	32	15	90	0	0	105	0	0	0	0	0	0	55	25	1	81	218
Peak Factor																					0.978
High Int.	04:30 PM																				
Volume	32	0	11	0	43	18	88	0	0	106	0	0	0	0	0	0	51	33	0	84	
Peak Factor					0.82						0.95						0.91				
					0						3						7				



2017 Existing A.M. Peak Hour													
Time		Southbound			Westbound			Northbound			Eastbound		
Start	End	SBR	SBT	SBL	WBR	WBT	WBL	NBR	NBT	NBL	EBR	EBT	EBL
6:30	6:45	0	0	0	0	36	1	4	0	7	9	48	0
6:45	7:00	0	0	0	0	43	2	5	0	8	12	51	0
7:00	7:15	0	0	0	0	67	5	9	0	9	17	72	0
7:15	7:30	0	0	0	0	102	18	25	0	15	10	122	0
7:30	7:45	0	0	0	0	176	44	44	0	16	13	113	0
7:45	8:00	0	0	0	0	191	24	19	0	13	13	95	0
8:00	8:15	0	0	0	0	64	14	7	0	12	11	48	0
8:15	8:30	0	0	0	0	57	2	3	0	12	10	39	0
Individual Turning Movements													
60-min total					0	536	91	97	0	53	53	402	0
(4 x 15-min) total					0	704	176	176	0	64	52	452	0
Individual Turning Movements													
60-min total					627			150			455		
(4 x 15-min) total					880			240			504		
<b>PHF</b>					<b>0.71</b>			<b>0.63</b>			<b>0.90</b>		

2017 Existing P.M. Peak Hour													
Time		Southbound			Westbound			Northbound			Eastbound		
Start	End	SBR	SBT	SBL	WBR	WBT	WBL	NBR	NBT	NBL	EBR	EBT	EBL
4:00	4:15	0	0	0	0	80	10	11	0	21	16	76	0
4:15	4:30	0	0	0	0	91	6	9	0	18	14	66	0
4:30	4:45	0	0	0	0	83	9	5	0	8	11	61	0
4:45	5:00	0	0	0	0	87	10	12	0	16	5	57	0
5:00	5:15	0	0	0	0	135	3	23	0	30	11	65	0
5:15	5:30	0	0	0	0	115	7	11	0	18	12	50	0
5:30	5:45	0	0	0	0	76	8	10	0	12	10	68	0
5:45	6:00	0	0	0	0	69	6	6	0	9	8	61	0
Individual Turning Movements													
60-min total					0	413	28	56	0	76	38	240	0
(4 x 15-min) total					0	540	12	92	0	120	44	260	0
Individual Turning Movements													
60-min total					441			132			278		
(4 x 15-min) total					552			212			304		
<b>PHF</b>					<b>0.80</b>			<b>0.62</b>			<b>0.91</b>		

LEGEND	60-min peak	15-min peak
--------	-------------	-------------

**Intersection**

Int Delay, s/veh 3.7

Movement	EBT	EBR	WBL	WBT	NBL	NBR
Lane Configurations	↑↑↑	↑	↑	↑↑↑	↑	↑
Traffic Vol, veh/h	402	53	91	536	49	84
Future Vol, veh/h	402	53	91	536	49	84
Conflicting Peds, #/hr	0	0	0	0	0	0
Sign Control	Free	Free	Free	Free	Stop	Stop
RT Channelized	-	None	-	None	-	None
Storage Length	-	175	200	-	0	0
Veh in Median Storage, #	0	-	-	0	0	-
Grade, %	0	-	-	0	0	-
Peak Hour Factor	90	90	52	76	77	54
Heavy Vehicles, %	2	2	2	2	2	2
Mvmt Flow	447	59	175	705	64	156

**Major/Minor**

	Major1	Major2	Minor1		
Conflicting Flow All	0	0	506	0	1079 224
Stage 1	-	-	-	-	447 -
Stage 2	-	-	-	-	632 -
Critical Hdwy	-	-	5.34	-	5.74 7.14
Critical Hdwy Stg 1	-	-	-	-	6.64 -
Critical Hdwy Stg 2	-	-	-	-	6.04 -
Follow-up Hdwy	-	-	3.12	-	3.82 3.92
Pot Cap-1 Maneuver	-	-	673	-	283 664
Stage 1	-	-	-	-	519 -
Stage 2	-	-	-	-	448 -
Platoon blocked, %	-	-	-	-	-
Mov Cap-1 Maneuver	-	-	673	-	209 664
Mov Cap-2 Maneuver	-	-	-	-	209 -
Stage 1	-	-	-	-	384 -
Stage 2	-	-	-	-	448 -

**Approach**

	EB	WB	NB
HCM Control Delay, s	0	2.4	17.2
HCM LOS			C

**Minor Lane/Major Mvmt**

	NBLn1	NBLn2	EBT	EBR	WBL	WBT
Capacity (veh/h)	209	664	-	-	673	-
HCM Lane V/C Ratio	0.304	0.234	-	-	0.26	-
HCM Control Delay (s)	29.6	12.1	-	-	12.2	-
HCM Lane LOS	D	B	-	-	B	-
HCM 95th %tile Q(veh)	1.2	0.9	-	-	1	-

**Intersection**

Int Delay, s/veh 0.4

Movement	EBL	EBT	EBR	WBL	WBT	WBR	NBL	NBT	NBR	SBL	SBT	SBR
Lane Configurations		↕			↕			↑	↗	↖	↘	↙
Traffic Vol, veh/h	10	0	1	0	0	0	0	123	0	0	141	3
Future Vol, veh/h	10	0	1	0	0	0	0	123	0	0	141	3
Conflicting Peds, #/hr	0	0	0	0	0	0	0	0	0	0	0	0
Sign Control	Stop	Stop	Stop	Stop	Stop	Stop	Free	Free	Free	Free	Free	Free
RT Channelized	-	-	None	-	-	None	-	-	None	-	-	None
Storage Length	-	-	-	-	-	-	-	-	150	0	-	-
Veh in Median Storage, #	-	0	-	-	0	-	-	0	-	-	0	-
Grade, %	-	0	-	-	0	-	-	0	-	-	0	-
Peak Hour Factor	80	80	80	80	80	80	63	63	63	63	63	63
Heavy Vehicles, %	2	2	2	2	2	2	2	2	2	2	2	2
Mvmt Flow	13	0	1	0	0	0	0	195	0	0	224	5

Major/Minor	Minor2		Minor1		Major1			Major2				
Conflicting Flow All	422	422	227	422	424	195	-	0	0	195	0	0
Stage 1	227	227	-	195	195	-	-	-	-	-	-	-
Stage 2	195	195	-	227	229	-	-	-	-	-	-	-
Critical Hdwy	7.12	6.52	6.22	7.12	6.52	6.22	-	-	-	4.12	-	-
Critical Hdwy Stg 1	6.12	5.52	-	6.12	5.52	-	-	-	-	-	-	-
Critical Hdwy Stg 2	6.12	5.52	-	6.12	5.52	-	-	-	-	-	-	-
Follow-up Hdwy	3.518	4.018	3.318	3.518	4.018	3.318	-	-	-	2.218	-	-
Pot Cap-1 Maneuver	542	523	812	542	522	846	0	-	-	1378	-	-
Stage 1	776	716	-	807	739	-	0	-	-	-	-	-
Stage 2	807	739	-	776	715	-	0	-	-	-	-	-
Platoon blocked, %												
Mov Cap-1 Maneuver	542	523	812	541	522	846	-	-	-	1378	-	-
Mov Cap-2 Maneuver	542	523	-	541	522	-	-	-	-	-	-	-
Stage 1	776	716	-	807	739	-	-	-	-	-	-	-
Stage 2	807	739	-	775	715	-	-	-	-	-	-	-

Approach	EB	WB	NB	SB
HCM Control Delay, s	11.6	0	0	0
HCM LOS	B	A		

Minor Lane/Major Mvmt	NBT	NBR	EBLn1WBLn1	SBL	SBT	SBR
Capacity (veh/h)	-	-	559	-	1378	-
HCM Lane V/C Ratio	-	-	0.025	-	-	-
HCM Control Delay (s)	-	-	11.6	0	0	-
HCM Lane LOS	-	-	B	A	A	-
HCM 95th %tile Q(veh)	-	-	0.1	-	0	-

**Intersection**

Int Delay, s/veh 1.7

Movement	EBL	EBT	EBR	WBL	WBT	WBR	NBL	NBT	NBR	SBL	SBT	SBR
Lane Configurations		↕			↕		↕	↑	↑	↕	↕	↕
Traffic Vol, veh/h	32	0	20	0	0	0	5	111	0	0	129	13
Future Vol, veh/h	32	0	20	0	0	0	5	111	0	0	129	13
Conflicting Peds, #/hr	0	0	0	0	0	0	0	0	0	0	0	0
Sign Control	Stop	Stop	Stop	Stop	Stop	Stop	Free	Free	Free	Free	Free	Free
RT Channelized	-	-	None	-	-	None	-	-	None	-	-	None
Storage Length	-	-	-	-	-	-	150	-	200	150	-	-
Veh in Median Storage, #	-	0	-	-	0	-	-	0	-	-	0	-
Grade, %	-	0	-	-	0	-	-	0	-	-	0	-
Peak Hour Factor	80	80	80	80	80	80	63	63	63	63	63	63
Heavy Vehicles, %	2	2	2	2	2	2	2	2	2	2	2	2
Mvmt Flow	40	0	25	0	0	0	8	176	0	0	205	21

Major/Minor	Minor2		Minor1		Major1		Major2					
Conflicting Flow All	408	408	216	420	418	176	226	0	0	176	0	0
Stage 1	216	216	-	192	192	-	-	-	-	-	-	-
Stage 2	192	192	-	228	226	-	-	-	-	-	-	-
Critical Hdwy	7.12	6.52	6.22	7.12	6.52	6.22	4.12	-	-	4.12	-	-
Critical Hdwy Stg 1	6.12	5.52	-	6.12	5.52	-	-	-	-	-	-	-
Critical Hdwy Stg 2	6.12	5.52	-	6.12	5.52	-	-	-	-	-	-	-
Follow-up Hdwy	3.518	4.018	3.318	3.518	4.018	3.318	2.218	-	-	2.218	-	-
Pot Cap-1 Maneuver	554	533	824	544	526	867	1342	-	-	1400	-	-
Stage 1	786	724	-	810	742	-	-	-	-	-	-	-
Stage 2	810	742	-	775	717	-	-	-	-	-	-	-
Platoon blocked, %								-	-	-	-	-
Mov Cap-1 Maneuver	551	530	824	525	523	867	1342	-	-	1400	-	-
Mov Cap-2 Maneuver	551	530	-	525	523	-	-	-	-	-	-	-
Stage 1	781	724	-	805	738	-	-	-	-	-	-	-
Stage 2	805	738	-	751	717	-	-	-	-	-	-	-

Approach	EB	WB	NB	SB
HCM Control Delay, s	11.4	0	0.3	0
HCM LOS	B	A		

Minor Lane/Major Mvmt	NBL	NBT	NBR	EBLn1WBLn1	SBL	SBT	SBR
Capacity (veh/h)	1342	-	-	631	-	1400	-
HCM Lane V/C Ratio	0.006	-	-	0.103	-	-	-
HCM Control Delay (s)	7.7	-	-	11.4	0	0	-
HCM Lane LOS	A	-	-	B	A	A	-
HCM 95th %tile Q(veh)	0	-	-	0.3	-	0	-



**Intersection**

Int Delay, s/veh 2.7

Movement	EBT	EBR	WBL	WBT	NBL	NBR
Lane Configurations	↑↑↑	↗	↘	↑↑↑	↘	↗
Traffic Vol, veh/h	240	58	28	413	72	48
Future Vol, veh/h	240	58	28	413	72	48
Conflicting Peds, #/hr	0	0	0	0	0	0
Sign Control	Free	Free	Free	Free	Stop	Stop
RT Channelized	-	None	-	None	-	None
Storage Length	-	175	200	-	0	0
Veh in Median Storage, #	0	-	-	0	0	-
Grade, %	0	-	-	0	0	-
Peak Hour Factor	91	91	80	80	60	60
Heavy Vehicles, %	2	2	2	2	2	2
Mvmt Flow	264	64	35	516	120	80

**Major/Minor**

	Major1	Major2	Minor1			
Conflicting Flow All	0	0	328	0	540	132
Stage 1	-	-	-	-	264	-
Stage 2	-	-	-	-	276	-
Critical Hdwy	-	-	5.34	-	5.74	7.14
Critical Hdwy Stg 1	-	-	-	-	6.64	-
Critical Hdwy Stg 2	-	-	-	-	6.04	-
Follow-up Hdwy	-	-	3.12	-	3.82	3.92
Pot Cap-1 Maneuver	-	-	815	-	523	759
Stage 1	-	-	-	-	664	-
Stage 2	-	-	-	-	684	-
Platoon blocked, %	-	-	-	-	-	-
Mov Cap-1 Maneuver	-	-	815	-	501	759
Mov Cap-2 Maneuver	-	-	-	-	501	-
Stage 1	-	-	-	-	635	-
Stage 2	-	-	-	-	684	-

**Approach**

	EB	WB	NB
HCM Control Delay, s	0	0.6	12.8
HCM LOS			B

**Minor Lane/Major Mvmt**

	NBLn1	NBLn2	EBT	EBR	WBL	WBT
Capacity (veh/h)	501	759	-	-	815	-
HCM Lane V/C Ratio	0.24	0.105	-	-	0.043	-
HCM Control Delay (s)	14.4	10.3	-	-	9.6	-
HCM Lane LOS	B	B	-	-	A	-
HCM 95th %tile Q(veh)	0.9	0.4	-	-	0.1	-

**Intersection**

Int Delay, s/veh 0.4

Movement	EBL	EBT	EBR	WBL	WBT	WBR	NBL	NBT	NBR	SBL	SBT	SBR
Lane Configurations		↔			↔			↑	↗	↖	↘	↙
Traffic Vol, veh/h	5	0	3	0	0	0	1	115	0	0	59	7
Future Vol, veh/h	5	0	3	0	0	0	1	115	0	0	59	7
Conflicting Peds, #/hr	0	0	0	0	0	0	0	0	0	0	0	0
Sign Control	Stop	Stop	Stop	Stop	Stop	Stop	Free	Free	Free	Free	Free	Free
RT Channelized	-	-	None	-	-	None	-	-	None	-	-	None
Storage Length	-	-	-	-	-	-	-	-	150	0	-	-
Veh in Median Storage, #	-	0	-	-	0	-	-	0	-	-	0	-
Grade, %	-	0	-	-	0	-	-	0	-	-	0	-
Peak Hour Factor	92	92	92	92	92	92	62	62	62	95	95	95
Heavy Vehicles, %	2	2	2	2	2	2	2	2	2	2	2	2
Mvmt Flow	5	0	3	0	0	0	2	185	0	0	62	7

Major/Minor	Minor2		Minor1		Major1		Major2					
Conflicting Flow All	255	255	66	256	258	185	69	0	0	185	0	0
Stage 1	66	66	-	189	189	-	-	-	-	-	-	-
Stage 2	189	189	-	67	69	-	-	-	-	-	-	-
Critical Hdwy	7.12	6.52	6.22	7.12	6.52	6.22	4.12	-	-	4.12	-	-
Critical Hdwy Stg 1	6.12	5.52	-	6.12	5.52	-	-	-	-	-	-	-
Critical Hdwy Stg 2	6.12	5.52	-	6.12	5.52	-	-	-	-	-	-	-
Follow-up Hdwy	3.518	4.018	3.318	3.518	4.018	3.318	2.218	-	-	2.218	-	-
Pot Cap-1 Maneuver	698	649	998	697	646	857	1532	-	-	1390	-	-
Stage 1	945	840	-	813	744	-	-	-	-	-	-	-
Stage 2	813	744	-	943	837	-	-	-	-	-	-	-
Platoon blocked, %								-	-	-	-	-
Mov Cap-1 Maneuver	697	648	998	694	645	857	1532	-	-	1390	-	-
Mov Cap-2 Maneuver	697	648	-	694	645	-	-	-	-	-	-	-
Stage 1	944	840	-	812	743	-	-	-	-	-	-	-
Stage 2	812	743	-	940	837	-	-	-	-	-	-	-

Approach	EB	WB	NB	SB
HCM Control Delay, s	9.6	0	0.1	0
HCM LOS	A	A		

Minor Lane/Major Mvmt	NBL	NBT	NBR	EBLn1WBLn1	SBL	SBT	SBR
Capacity (veh/h)	1532	-	-	786	-	1390	-
HCM Lane V/C Ratio	0.001	-	-	0.011	-	-	-
HCM Control Delay (s)	7.4	-	-	9.6	0	0	-
HCM Lane LOS	A	-	-	A	A	A	-
HCM 95th %tile Q(veh)	0	-	-	0	-	0	-

Intersection												
Int Delay, s/veh	1.8											
Movement	EBL	EBT	EBR	WBL	WBT	WBR	NBL	NBT	NBR	SBL	SBT	SBR
Lane Configurations		↕			↕		↗	↑	↖	↗	↖	↖
Traffic Vol, veh/h	15	0	10	0	0	0	22	101	0	0	36	26
Future Vol, veh/h	15	0	10	0	0	0	22	101	0	0	36	26
Conflicting Peds, #/hr	0	0	0	0	0	0	0	0	0	0	0	0
Sign Control	Stop	Stop	Stop	Stop	Stop	Stop	Free	Free	Free	Free	Free	Free
RT Channelized	-	-	None	-	-	None	-	-	None	-	-	None
Storage Length	-	-	-	-	-	-	150	-	0	150	-	-
Veh in Median Storage, #	-	0	-	-	0	-	-	0	-	-	0	-
Grade, %	-	0	-	-	0	-	-	0	-	-	0	-
Peak Hour Factor	92	92	92	92	92	92	62	62	62	95	95	95
Heavy Vehicles, %	2	2	2	2	2	2	2	2	2	2	2	2
Mvmt Flow	16	0	11	0	0	0	35	163	0	0	38	27

Major/Minor	Minor2		Minor1		Major1		Major2					
Conflicting Flow All	285	285	52	290	298	163	65	0	0	163	0	0
Stage 1	52	52	-	233	233	-	-	-	-	-	-	-
Stage 2	233	233	-	57	65	-	-	-	-	-	-	-
Critical Hdwy	7.12	6.52	6.22	7.12	6.52	6.22	4.12	-	-	4.12	-	-
Critical Hdwy Stg 1	6.12	5.52	-	6.12	5.52	-	-	-	-	-	-	-
Critical Hdwy Stg 2	6.12	5.52	-	6.12	5.52	-	-	-	-	-	-	-
Follow-up Hdwy	3.518	4.018	3.318	3.518	4.018	3.318	2.218	-	-	2.218	-	-
Pot Cap-1 Maneuver	667	624	1016	662	614	882	1537	-	-	1416	-	-
Stage 1	961	852	-	770	712	-	-	-	-	-	-	-
Stage 2	770	712	-	955	841	-	-	-	-	-	-	-
Platoon blocked, %								-	-	-	-	-
Mov Cap-1 Maneuver	656	610	1016	643	600	882	1537	-	-	1416	-	-
Mov Cap-2 Maneuver	656	610	-	643	600	-	-	-	-	-	-	-
Stage 1	939	852	-	752	696	-	-	-	-	-	-	-
Stage 2	752	696	-	945	841	-	-	-	-	-	-	-

Approach	EB	WB	NB	SB
HCM Control Delay, s	9.9	0	1.3	0
HCM LOS	A	A		

Minor Lane/Major Mvmt	NBL	NBT	NBR	EBLn1WBLn1	SBL	SBT	SBR
Capacity (veh/h)	1537	-	-	764	-	1416	-
HCM Lane V/C Ratio	0.023	-	-	0.036	-	-	-
HCM Control Delay (s)	7.4	-	-	9.9	0	0	-
HCM Lane LOS	A	-	-	A	A	A	-
HCM 95th %tile Q(veh)	0.1	-	-	0.1	-	0	-

Intersection						
Int Delay, s/veh	4.4					
Movement	EBT	EBR	WBL	WBT	NBL	NBR
Lane Configurations	↑↑↑	↑	↑	↑↑↑	↑	↑
Traffic Vol, veh/h	402	57	94	536	65	97
Future Vol, veh/h	402	57	94	536	65	97
Conflicting Peds, #/hr	0	0	0	0	0	0
Sign Control	Free	Free	Free	Free	Stop	Stop
RT Channelized	-	None	-	None	-	None
Storage Length	-	175	200	-	0	0
Veh in Median Storage, #	0	-	-	0	0	-
Grade, %	0	-	-	0	0	-
Peak Hour Factor	90	90	52	76	77	54
Heavy Vehicles, %	2	2	2	2	2	2
Mvmt Flow	447	63	181	705	84	180

Major/Minor	Major1	Major2	Minor1	Minor2	Minor3
Conflicting Flow All	0	0	510	0	1091
Stage 1	-	-	-	-	447
Stage 2	-	-	-	-	644
Critical Hdwy	-	-	5.34	-	5.74
Critical Hdwy Stg 1	-	-	-	-	6.64
Critical Hdwy Stg 2	-	-	-	-	6.04
Follow-up Hdwy	-	-	3.12	-	3.82
Pot Cap-1 Maneuver	-	-	670	-	279
Stage 1	-	-	-	-	519
Stage 2	-	-	-	-	442
Platoon blocked, %	-	-	-	-	-
Mov Cap-1 Maneuver	-	-	670	-	204
Mov Cap-2 Maneuver	-	-	-	-	204
Stage 1	-	-	-	-	379
Stage 2	-	-	-	-	442

Approach	EB	WB	NB
HCM Control Delay, s	0	2.5	19.5
HCM LOS			C

Minor Lane/Major Mvmt	NBLn1	NBLn2	EBT	EBR	WBL	WBT
Capacity (veh/h)	204	664	-	-	670	-
HCM Lane V/C Ratio	0.414	0.271	-	-	0.27	-
HCM Control Delay (s)	34.6	12.4	-	-	12.3	-
HCM Lane LOS	D	B	-	-	B	-
HCM 95th %tile Q(veh)	1.9	1.1	-	-	1.1	-

Intersection												
Int Delay, s/veh	0.6											
Movement	EBL	EBT	EBR	WBL	WBT	WBR	NBL	NBT	NBR	SBL	SBT	SBR
Lane Configurations			↗			↗		↑	↗	↖	↖	
Traffic Vol, veh/h	0	0	1	0	0	18	0	134	1	4	144	3
Future Vol, veh/h	0	0	1	0	0	18	0	134	1	4	144	3
Conflicting Peds, #/hr	0	0	0	0	0	0	0	0	0	0	0	0
Sign Control	Stop	Stop	Stop	Stop	Stop	Stop	Free	Free	Free	Free	Free	Free
RT Channelized	-	-	None	-	-	None	-	-	None	-	-	None
Storage Length	-	-	0	-	-	0	-	-	150	0	-	-
Veh in Median Storage, #	-	0	-	-	0	-	-	0	-	-	0	-
Grade, %	-	0	-	-	0	-	-	0	-	-	0	-
Peak Hour Factor	80	80	80	80	80	80	63	63	63	63	63	63
Heavy Vehicles, %	2	2	2	2	2	2	2	2	2	2	2	2
Mvmt Flow	0	0	1	0	0	23	0	213	2	6	229	5

Major/Minor	Minor2		Minor1		Major1		Major2					
Conflicting Flow All	-	-	232	-	-	213	-	0	0	215	0	0
Stage 1	-	-	-	-	-	-	-	-	-	-	-	-
Stage 2	-	-	-	-	-	-	-	-	-	-	-	-
Critical Hdwy	-	-	6.22	-	-	6.22	-	-	-	4.12	-	-
Critical Hdwy Stg 1	-	-	-	-	-	-	-	-	-	-	-	-
Critical Hdwy Stg 2	-	-	-	-	-	-	-	-	-	-	-	-
Follow-up Hdwy	-	-	3.318	-	-	3.318	-	-	-	2.218	-	-
Pot Cap-1 Maneuver	0	0	807	0	0	827	0	-	-	1355	-	-
Stage 1	0	0	-	0	0	-	0	-	-	-	-	-
Stage 2	0	0	-	0	0	-	0	-	-	-	-	-
Platoon blocked, %	-	-	-	-	-	-	-	-	-	-	-	-
Mov Cap-1 Maneuver	-	-	807	-	-	827	-	-	-	1355	-	-
Mov Cap-2 Maneuver	-	-	-	-	-	-	-	-	-	-	-	-
Stage 1	-	-	-	-	-	-	-	-	-	-	-	-
Stage 2	-	-	-	-	-	-	-	-	-	-	-	-

Approach	EB		WB		NB		SB	
HCM Control Delay, s	9.5		9.5		0		0.2	
HCM LOS	A		A					

Minor Lane/Major Mvmt	NBT	NBR	EBLn1WBLn1	SBL	SBT	SBR
Capacity (veh/h)	-	-	807	827	1355	-
HCM Lane V/C Ratio	-	-	0.002	0.027	0.005	-
HCM Control Delay (s)	-	-	9.5	9.5	7.7	-
HCM Lane LOS	-	-	A	A	A	-
HCM 95th %tile Q(veh)	-	-	0	0.1	0	-

**Intersection**

Int Delay, s/veh 2.4

Movement	EBL	EBT	EBR	WBL	WBT	WBR	NBL	NBT	NBR	SBL	SBT	SBR
Lane Configurations		↕			↕		↕	↑	↑	↕	↕	↕
Traffic Vol, veh/h	32	0	20	16	0	11	5	112	1	3	129	13
Future Vol, veh/h	32	0	20	16	0	11	5	112	1	3	129	13
Conflicting Peds, #/hr	0	0	0	0	0	0	0	0	0	0	0	0
Sign Control	Stop	Stop	Stop	Stop	Stop	Stop	Free	Free	Free	Free	Free	Free
RT Channelized	-	-	None	-	-	None	-	-	None	-	-	None
Storage Length	-	-	-	-	-	-	150	-	200	150	-	-
Veh in Median Storage, #	-	0	-	-	0	-	-	0	-	-	0	-
Grade, %	-	0	-	-	0	-	-	0	-	-	0	-
Peak Hour Factor	80	80	80	80	80	80	63	63	63	63	63	63
Heavy Vehicles, %	2	2	2	2	2	2	2	2	2	2	2	2
Mvmt Flow	40	0	25	20	0	14	8	178	2	5	205	21

Major/Minor	Minor2		Minor1		Major1		Major2					
Conflicting Flow All	428	422	216	432	430	178	226	0	0	180	0	0
Stage 1	226	226	-	194	194	-	-	-	-	-	-	-
Stage 2	202	196	-	238	236	-	-	-	-	-	-	-
Critical Hdwy	7.12	6.52	6.22	7.12	6.52	6.22	4.12	-	-	4.12	-	-
Critical Hdwy Stg 1	6.12	5.52	-	6.12	5.52	-	-	-	-	-	-	-
Critical Hdwy Stg 2	6.12	5.52	-	6.12	5.52	-	-	-	-	-	-	-
Follow-up Hdwy	3.518	4.018	3.318	3.518	4.018	3.318	2.218	-	-	2.218	-	-
Pot Cap-1 Maneuver	537	523	824	534	518	865	1342	-	-	1396	-	-
Stage 1	777	717	-	808	740	-	-	-	-	-	-	-
Stage 2	800	739	-	765	710	-	-	-	-	-	-	-
Platoon blocked, %								-	-	-	-	-
Mov Cap-1 Maneuver	525	518	824	514	513	865	1342	-	-	1396	-	-
Mov Cap-2 Maneuver	525	518	-	514	513	-	-	-	-	-	-	-
Stage 1	772	714	-	803	736	-	-	-	-	-	-	-
Stage 2	783	735	-	739	707	-	-	-	-	-	-	-

Approach	EB		WB		NB		SB	
HCM Control Delay, s	11.6		11.2		0.3		0.2	
HCM LOS	B		B					

Minor Lane/Major Mvmt	NBL	NBT	NBR	EBLn1WBLn1	SBL	SBT	SBR
Capacity (veh/h)	1342	-	-	610	616	1396	-
HCM Lane V/C Ratio	0.006	-	-	0.107	0.055	0.003	-
HCM Control Delay (s)	7.7	-	-	11.6	11.2	7.6	-
HCM Lane LOS	A	-	-	B	B	A	-
HCM 95th %tile Q(veh)	0	-	-	0.4	0.2	0	-

**Intersection**

Int Delay, s/veh 3

Movement	EBT	EBR	WBL	WBT	NBL	NBR
Lane Configurations	↑↑↑	↗	↘	↑↑↑	↘	↗
Traffic Vol, veh/h	240	73	39	413	80	52
Future Vol, veh/h	240	73	39	413	80	52
Conflicting Peds, #/hr	0	0	0	0	0	0
Sign Control	Free	Free	Free	Free	Stop	Stop
RT Channelized	-	None	-	None	-	None
Storage Length	-	175	200	-	0	0
Veh in Median Storage, #	0	-	-	0	0	-
Grade, %	0	-	-	0	0	-
Peak Hour Factor	91	91	80	80	60	60
Heavy Vehicles, %	2	2	2	2	2	2
Mvmt Flow	264	80	49	516	133	87

**Major/Minor**

	Major1	Major2	Minor1		
Conflicting Flow All	0	0	344	0	568
Stage 1	-	-	-	-	264
Stage 2	-	-	-	-	304
Critical Hdwy	-	-	5.34	-	5.74
Critical Hdwy Stg 1	-	-	-	-	6.64
Critical Hdwy Stg 2	-	-	-	-	6.04
Follow-up Hdwy	-	-	3.12	-	3.82
Pot Cap-1 Maneuver	-	-	801	-	507
Stage 1	-	-	-	-	664
Stage 2	-	-	-	-	662
Platoon blocked, %	-	-	-	-	-
Mov Cap-1 Maneuver	-	-	801	-	476
Mov Cap-2 Maneuver	-	-	-	-	476
Stage 1	-	-	-	-	623
Stage 2	-	-	-	-	662

**Approach**

	EB	WB	NB
HCM Control Delay, s	0	0.8	13.5
HCM LOS			B

**Minor Lane/Major Mvmt**

	NBLn1	NBLn2	EBT	EBR	WBL	WBT
Capacity (veh/h)	476	759	-	-	801	-
HCM Lane V/C Ratio	0.28	0.114	-	-	0.061	-
HCM Control Delay (s)	15.5	10.4	-	-	9.8	-
HCM Lane LOS	C	B	-	-	A	-
HCM 95th %tile Q(veh)	1.1	0.4	-	-	0.2	-

Intersection												
Int Delay, s/veh	0.9											
Movement	EBL	EBT	EBR	WBL	WBT	WBR	NBL	NBT	NBR	SBL	SBT	SBR
Lane Configurations			↗			↗		↑	↗	↖	↖	
Traffic Vol, veh/h	0	0	8	0	0	8	1	119	9	15	70	7
Future Vol, veh/h	0	0	8	0	0	8	1	119	9	15	70	7
Conflicting Peds, #/hr	0	0	0	0	0	0	0	0	0	0	0	0
Sign Control	Stop	Stop	Stop	Stop	Stop	Stop	Free	Free	Free	Free	Free	Free
RT Channelized	-	-	None	-	-	None	-	-	None	-	-	None
Storage Length	-	-	0	-	-	0	-	-	150	0	-	-
Veh in Median Storage, #	-	0	-	-	0	-	-	0	-	-	0	-
Grade, %	-	0	-	-	0	-	-	0	-	-	0	-
Peak Hour Factor	92	92	92	92	92	92	62	62	62	95	95	95
Heavy Vehicles, %	2	2	2	2	2	2	2	2	2	2	2	2
Mvmt Flow	0	0	9	0	0	9	2	192	15	16	74	7

Major/Minor	Minor2		Minor1		Major1		Major2					
Conflicting Flow All	-	-	78	-	-	192	81	0	0	207	0	0
Stage 1	-	-	-	-	-	-	-	-	-	-	-	-
Stage 2	-	-	-	-	-	-	-	-	-	-	-	-
Critical Hdwy	-	-	6.22	-	-	6.22	4.12	-	-	4.12	-	-
Critical Hdwy Stg 1	-	-	-	-	-	-	-	-	-	-	-	-
Critical Hdwy Stg 2	-	-	-	-	-	-	-	-	-	-	-	-
Follow-up Hdwy	-	-	3.318	-	-	3.318	2.218	-	-	2.218	-	-
Pot Cap-1 Maneuver	0	0	983	0	0	850	1517	-	-	1364	-	-
Stage 1	0	0	-	0	0	-	-	-	-	-	-	-
Stage 2	0	0	-	0	0	-	-	-	-	-	-	-
Platoon blocked, %	-	-	-	-	-	-	-	-	-	-	-	-
Mov Cap-1 Maneuver	-	-	983	-	-	850	1517	-	-	1364	-	-
Mov Cap-2 Maneuver	-	-	-	-	-	-	-	-	-	-	-	-
Stage 1	-	-	-	-	-	-	-	-	-	-	-	-
Stage 2	-	-	-	-	-	-	-	-	-	-	-	-

Approach	EB		WB		NB		SB			
HCM Control Delay, s	8.7		9.3		0.1		1.3			
HCM LOS	A		A							

Minor Lane/Major Mvmt	NBL	NBT	NBR	EBLn1	WBLn1	SBL	SBT	SBR
Capacity (veh/h)	1517	-	-	983	850	1364	-	-
HCM Lane V/C Ratio	0.001	-	-	0.009	0.01	0.012	-	-
HCM Control Delay (s)	7.4	-	-	8.7	9.3	7.7	-	-
HCM Lane LOS	A	-	-	A	A	A	-	-
HCM 95th %tile Q(veh)	0	-	-	0	0	0	-	-



Intersection												
Int Delay, s/veh	2.3											
Movement	EBL	EBT	EBR	WBL	WBT	WBR	NBL	NBT	NBR	SBL	SBT	SBR
Lane Configurations		↕			↕		↕	↑	↑	↕	↕	↕
Traffic Vol, veh/h	15	0	10	9	0	4	22	110	8	11	36	26
Future Vol, veh/h	15	0	10	9	0	4	22	110	8	11	36	26
Conflicting Peds, #/hr	0	0	0	0	0	0	0	0	0	0	0	0
Sign Control	Stop	Stop	Stop	Stop	Stop	Stop	Free	Free	Free	Free	Free	Free
RT Channelized	-	-	None	-	-	None	-	-	None	-	-	None
Storage Length	-	-	-	-	-	-	150	-	0	150	-	-
Veh in Median Storage, #	-	0	-	-	0	-	-	0	-	-	0	-
Grade, %	-	0	-	-	0	-	-	0	-	-	0	-
Peak Hour Factor	92	92	92	92	92	92	62	62	62	95	95	95
Heavy Vehicles, %	2	2	2	2	2	2	2	2	2	2	2	2
Mvmt Flow	16	0	11	10	0	4	35	177	13	12	38	27

Major/Minor	Minor2		Minor1		Major1			Major2				
Conflicting Flow All	332	336	52	328	336	177	65	0	0	190	0	0
Stage 1	76	76	-	247	247	-	-	-	-	-	-	-
Stage 2	256	260	-	81	89	-	-	-	-	-	-	-
Critical Hdwy	7.12	6.52	6.22	7.12	6.52	6.22	4.12	-	-	4.12	-	-
Critical Hdwy Stg 1	6.12	5.52	-	6.12	5.52	-	-	-	-	-	-	-
Critical Hdwy Stg 2	6.12	5.52	-	6.12	5.52	-	-	-	-	-	-	-
Follow-up Hdwy	3.518	4.018	3.318	3.518	4.018	3.318	2.218	-	-	2.218	-	-
Pot Cap-1 Maneuver	621	585	1016	625	585	866	1537	-	-	1384	-	-
Stage 1	933	832	-	757	702	-	-	-	-	-	-	-
Stage 2	749	693	-	927	821	-	-	-	-	-	-	-
Platoon blocked, %								-	-	-	-	-
Mov Cap-1 Maneuver	603	566	1016	604	566	866	1537	-	-	1384	-	-
Mov Cap-2 Maneuver	603	566	-	604	566	-	-	-	-	-	-	-
Stage 1	912	825	-	740	686	-	-	-	-	-	-	-
Stage 2	728	677	-	909	814	-	-	-	-	-	-	-

Approach	EB		WB		NB		SB	
HCM Control Delay, s	10.2		10.5		1.2		1.1	
HCM LOS	B		B					

Minor Lane/Major Mvmt	NBL	NBT	NBR	EBLn1WBLn1	SBL	SBT	SBR
Capacity (veh/h)	1537	-	-	720	666	1384	-
HCM Lane V/C Ratio	0.023	-	-	0.038	0.021	0.008	-
HCM Control Delay (s)	7.4	-	-	10.2	10.5	7.6	-
HCM Lane LOS	A	-	-	B	B	A	-
HCM 95th %tile Q(veh)	0.1	-	-	0.1	0.1	0	-

**Intersection**

Int Delay, s/veh 23.1

Movement	EBT	EBR	WBL	WBT	NBL	NBR
Lane Configurations	↑↑↑	↗	↘	↑↑↑	↘	↗
Traffic Vol, veh/h	700	100	100	1600	85	150
Future Vol, veh/h	700	100	100	1600	85	150
Conflicting Peds, #/hr	0	0	0	0	0	0
Sign Control	Free	Free	Free	Free	Stop	Stop
RT Channelized	-	None	-	None	-	None
Storage Length	-	175	200	-	0	0
Veh in Median Storage, #	0	-	-	0	0	-
Grade, %	0	-	-	0	0	-
Peak Hour Factor	90	90	52	76	77	54
Heavy Vehicles, %	2	2	2	2	2	2
Mvmt Flow	778	111	192	2105	110	278

**Major/Minor**

	Major1	Major2	Minor1		
Conflicting Flow All	0	0	889	0	2004 389
Stage 1	-	-	-	-	778 -
Stage 2	-	-	-	-	1226 -
Critical Hdwy	-	-	5.34	-	5.74 7.14
Critical Hdwy Stg 1	-	-	-	-	6.64 -
Critical Hdwy Stg 2	-	-	-	-	6.04 -
Follow-up Hdwy	-	-	3.12	-	3.82 3.92
Pot Cap-1 Maneuver	-	-	443	-	~ 93 521
Stage 1	-	-	-	-	330 -
Stage 2	-	-	-	-	215 -
Platoon blocked, %	-	-	-	-	-
Mov Cap-1 Maneuver	-	-	443	-	~ 53 521
Mov Cap-2 Maneuver	-	-	-	-	~ 53 -
Stage 1	-	-	-	-	187 -
Stage 2	-	-	-	-	215 -

**Approach**

	EB	WB	NB
HCM Control Delay, s	0	1.6	203.7
HCM LOS			F

**Minor Lane/Major Mvmt**

	NBLn1	NBLn2	EBT	EBR	WBL	WBT
Capacity (veh/h)	53	521	-	-	443	-
HCM Lane V/C Ratio	2.083	0.533	-	-	0.434	-
HCM Control Delay (s)	\$ 667.3	19.5	-	-	19.2	-
HCM Lane LOS	F	C	-	-	C	-
HCM 95th %tile Q(veh)	11	3.1	-	-	2.2	-

**Notes**

-: Volume exceeds capacity    \$: Delay exceeds 300s    +: Computation Not Defined    \*: All major volume in platoon

Intersection												
Int Delay, s/veh	0.3											
Movement	EBL	EBT	EBR	WBL	WBT	WBR	NBL	NBT	NBR	SBL	SBT	SBR
Lane Configurations		↔			↔			↑	↗	↖	↘	
Traffic Vol, veh/h	10	0	1	0	0	0	0	225	0	0	247	3
Future Vol, veh/h	10	0	1	0	0	0	0	225	0	0	247	3
Conflicting Peds, #/hr	0	0	0	0	0	0	0	0	0	0	0	0
Sign Control	Stop	Stop	Stop	Stop	Stop	Stop	Free	Free	Free	Free	Free	Free
RT Channelized	-	-	None	-	-	None	-	-	None	-	-	None
Storage Length	-	-	-	-	-	-	-	-	150	0	-	-
Veh in Median Storage, #	-	0	-	-	0	-	-	0	-	-	0	-
Grade, %	-	0	-	-	0	-	-	0	-	-	0	-
Peak Hour Factor	80	80	80	80	80	80	63	63	63	63	63	63
Heavy Vehicles, %	2	2	2	2	2	2	2	2	2	2	2	2
Mvmt Flow	13	0	1	0	0	0	0	357	0	0	392	5

Major/Minor	Minor2		Minor1		Major1			Major2				
Conflicting Flow All	752	752	395	752	754	357	-	0	0	357	0	0
Stage 1	395	395	-	357	357	-	-	-	-	-	-	-
Stage 2	357	357	-	395	397	-	-	-	-	-	-	-
Critical Hdwy	7.12	6.52	6.22	7.12	6.52	6.22	-	-	-	4.12	-	-
Critical Hdwy Stg 1	6.12	5.52	-	6.12	5.52	-	-	-	-	-	-	-
Critical Hdwy Stg 2	6.12	5.52	-	6.12	5.52	-	-	-	-	-	-	-
Follow-up Hdwy	3.518	4.018	3.318	3.518	4.018	3.318	-	-	-	2.218	-	-
Pot Cap-1 Maneuver	327	339	654	327	338	687	0	-	-	1202	-	-
Stage 1	630	605	-	661	628	-	0	-	-	-	-	-
Stage 2	661	628	-	630	603	-	0	-	-	-	-	-
Platoon blocked, %								-	-	-	-	-
Mov Cap-1 Maneuver	327	339	654	326	338	687	-	-	-	1202	-	-
Mov Cap-2 Maneuver	327	339	-	326	338	-	-	-	-	-	-	-
Stage 1	630	605	-	661	628	-	-	-	-	-	-	-
Stage 2	661	628	-	629	603	-	-	-	-	-	-	-

Approach	EB		WB		NB		SB	
HCM Control Delay, s	15.9		0		0		0	
HCM LOS	C		A					

Minor Lane/Major Mvmt	NBT	NBR	EBLn1WBLn1	SBL	SBT	SBR
Capacity (veh/h)	-	-	343	-	1202	-
HCM Lane V/C Ratio	-	-	0.04	-	-	-
HCM Control Delay (s)	-	-	15.9	0	0	-
HCM Lane LOS	-	-	C	A	A	-
HCM 95th %tile Q(veh)	-	-	0.1	-	0	-

Intersection												
Int Delay, s/veh	1.3											
Movement	EBL	EBT	EBR	WBL	WBT	WBR	NBL	NBT	NBR	SBL	SBT	SBR
Lane Configurations		↕			↕		↗	↑	↖	↗	↖	↖
Traffic Vol, veh/h	32	0	20	0	0	0	5	203	0	0	235	13
Future Vol, veh/h	32	0	20	0	0	0	5	203	0	0	235	13
Conflicting Peds, #/hr	0	0	0	0	0	0	0	0	0	0	0	0
Sign Control	Stop	Stop	Stop	Stop	Stop	Stop	Free	Free	Free	Free	Free	Free
RT Channelized	-	-	None	-	-	None	-	-	None	-	-	None
Storage Length	-	-	-	-	-	-	150	-	200	150	-	-
Veh in Median Storage, #	-	0	-	-	0	-	-	0	-	-	0	-
Grade, %	-	0	-	-	0	-	-	0	-	-	0	-
Peak Hour Factor	80	80	80	80	80	80	63	63	63	63	63	63
Heavy Vehicles, %	2	2	2	2	2	2	2	2	2	2	2	2
Mvmt Flow	40	0	25	0	0	0	8	322	0	0	373	21

Major/Minor	Minor2		Minor1		Major1		Major2					
Conflicting Flow All	722	722	384	734	732	322	394	0	0	322	0	0
Stage 1	384	384	-	338	338	-	-	-	-	-	-	-
Stage 2	338	338	-	396	394	-	-	-	-	-	-	-
Critical Hdwy	7.12	6.52	6.22	7.12	6.52	6.22	4.12	-	-	4.12	-	-
Critical Hdwy Stg 1	6.12	5.52	-	6.12	5.52	-	-	-	-	-	-	-
Critical Hdwy Stg 2	6.12	5.52	-	6.12	5.52	-	-	-	-	-	-	-
Follow-up Hdwy	3.518	4.018	3.318	3.518	4.018	3.318	2.218	-	-	2.218	-	-
Pot Cap-1 Maneuver	342	353	664	336	348	719	1165	-	-	1238	-	-
Stage 1	639	611	-	676	641	-	-	-	-	-	-	-
Stage 2	676	641	-	629	605	-	-	-	-	-	-	-
Platoon blocked, %								-	-	-	-	-
Mov Cap-1 Maneuver	340	351	664	322	346	719	1165	-	-	1238	-	-
Mov Cap-2 Maneuver	340	351	-	322	346	-	-	-	-	-	-	-
Stage 1	635	611	-	671	637	-	-	-	-	-	-	-
Stage 2	671	637	-	605	605	-	-	-	-	-	-	-

Approach	EB		WB		NB		SB			
HCM Control Delay, s	15.2		0		0.2		0			
HCM LOS	C		A							

Minor Lane/Major Mvmt	NBL	NBT	NBR	EBLn1WBLn1	SBL	SBT	SBR
Capacity (veh/h)	1165	-	-	419	-	1238	-
HCM Lane V/C Ratio	0.007	-	-	0.155	-	-	-
HCM Control Delay (s)	8.1	-	-	15.2	0	0	-
HCM Lane LOS	A	-	-	C	A	A	-
HCM 95th %tile Q(veh)	0	-	-	0.5	-	0	-

**Intersection**

Int Delay, s/veh 608.1

Movement	EBT	EBR	WBL	WBT	NBL	NBR
Lane Configurations	↑↑↑	↑	↑	↑↑↑	↑	↑
Traffic Vol, veh/h	1475	125	100	1250	150	175
Future Vol, veh/h	1475	125	100	1250	150	175
Conflicting Peds, #/hr	0	0	0	0	0	0
Sign Control	Free	Free	Free	Free	Stop	Stop
RT Channelized	-	None	-	None	-	None
Storage Length	-	175	200	-	0	0
Veh in Median Storage, #	0	-	-	0	0	-
Grade, %	0	-	-	0	0	-
Peak Hour Factor	91	91	80	80	60	60
Heavy Vehicles, %	2	2	2	2	2	2
Mvmt Flow	1621	137	125	1563	250	292

**Major/Minor**

	Major1	Major2	Minor1		
Conflicting Flow All	0	0	1758	0	2496 811
Stage 1	-	-	-	-	1621 -
Stage 2	-	-	-	-	875 -
Critical Hdwy	-	-	5.34	-	5.74 7.14
Critical Hdwy Stg 1	-	-	-	-	6.64 -
Critical Hdwy Stg 2	-	-	-	-	6.04 -
Follow-up Hdwy	-	-	3.12	-	3.82 3.92
Pot Cap-1 Maneuver	-	-	166	-	~ 50 ~ 277
Stage 1	-	-	-	-	~ 99 -
Stage 2	-	-	-	-	333 -
Platoon blocked, %	-	-	-	-	-
Mov Cap-1 Maneuver	-	-	166	-	~ 12 ~ 277
Mov Cap-2 Maneuver	-	-	-	-	~ 12 -
Stage 1	-	-	-	-	~ 24 -
Stage 2	-	-	-	-	333 -

**Approach**

	EB	WB	NB
HCM Control Delay, s	0	5.4	\$ 4459.5
HCM LOS			F

**Minor Lane/Major Mvmt**

	NBLn1	NBLn2	EBT	EBR	WBL	WBT
Capacity (veh/h)	12	277	-	-	166	-
HCM Lane V/C Ratio	20.833	1.053	-	-	0.753	-
HCM Control Delay (s)	\$ 9534.7	109.3	-	-	73.3	-
HCM Lane LOS	F	F	-	-	F	-
HCM 95th %tile Q(veh)	32.6	11.4	-	-	4.7	-

**Notes**

~: Volume exceeds capacity    \$: Delay exceeds 300s    +: Computation Not Defined    \*: All major volume in platoon

Intersection												
Int Delay, s/veh	0.2											
Movement	EBL	EBT	EBR	WBL	WBT	WBR	NBL	NBT	NBR	SBL	SBT	SBR
Lane Configurations		↕			↕			↑	↗	↖	↘	↙
Traffic Vol, veh/h	5	0	3	0	0	0	1	320	0	0	218	7
Future Vol, veh/h	5	0	3	0	0	0	1	320	0	0	218	7
Conflicting Peds, #/hr	0	0	0	0	0	0	0	0	0	0	0	0
Sign Control	Stop	Stop	Stop	Stop	Stop	Stop	Free	Free	Free	Free	Free	Free
RT Channelized	-	-	None	-	-	None	-	-	None	-	-	None
Storage Length	-	-	-	-	-	-	-	-	150	0	-	-
Veh in Median Storage, #	-	0	-	-	0	-	-	0	-	-	0	-
Grade, %	-	0	-	-	0	-	-	0	-	-	0	-
Peak Hour Factor	92	92	92	92	92	92	62	62	62	95	95	95
Heavy Vehicles, %	2	2	2	2	2	2	2	2	2	2	2	2
Mvmt Flow	5	0	3	0	0	0	2	516	0	0	229	7

Major/Minor	Minor2		Minor1		Major1			Major2				
Conflicting Flow All	753	753	233	754	756	516	236	0	0	516	0	0
Stage 1	233	233	-	520	520	-	-	-	-	-	-	-
Stage 2	520	520	-	234	236	-	-	-	-	-	-	-
Critical Hdwy	7.12	6.52	6.22	7.12	6.52	6.22	4.12	-	-	4.12	-	-
Critical Hdwy Stg 1	6.12	5.52	-	6.12	5.52	-	-	-	-	-	-	-
Critical Hdwy Stg 2	6.12	5.52	-	6.12	5.52	-	-	-	-	-	-	-
Follow-up Hdwy	3.518	4.018	3.318	3.518	4.018	3.318	2.218	-	-	2.218	-	-
Pot Cap-1 Maneuver	326	339	806	326	337	559	1331	-	-	1050	-	-
Stage 1	770	712	-	539	532	-	-	-	-	-	-	-
Stage 2	539	532	-	769	710	-	-	-	-	-	-	-
Platoon blocked, %								-	-	-	-	-
Mov Cap-1 Maneuver	325	338	806	324	336	559	1331	-	-	1050	-	-
Mov Cap-2 Maneuver	325	338	-	324	336	-	-	-	-	-	-	-
Stage 1	768	712	-	538	531	-	-	-	-	-	-	-
Stage 2	538	531	-	766	710	-	-	-	-	-	-	-

Approach	EB		WB		NB			SB		
HCM Control Delay, s	13.8		0		0			0		
HCM LOS	B		A							

Minor Lane/Major Mvmt	NBL	NBT	NBR	EBLn1	WBLn1	SBL	SBT	SBR
Capacity (veh/h)	1331	-	-	419	-	1050	-	-
HCM Lane V/C Ratio	0.001	-	-	0.021	-	-	-	-
HCM Control Delay (s)	7.7	-	-	13.8	0	0	-	-
HCM Lane LOS	A	-	-	B	A	A	-	-
HCM 95th %tile Q(veh)	0	-	-	0.1	-	0	-	-

Intersection												
Int Delay, s/veh	0.8											
Movement	EBL	EBT	EBR	WBL	WBT	WBR	NBL	NBT	NBR	SBL	SBT	SBR
Lane Configurations		↕			↕		↗	↑	↖	↗	↖	↖
Traffic Vol, veh/h	15	0	10	0	0	0	22	306	0	0	195	26
Future Vol, veh/h	15	0	10	0	0	0	22	306	0	0	195	26
Conflicting Peds, #/hr	0	0	0	0	0	0	0	0	0	0	0	0
Sign Control	Stop	Stop	Stop	Stop	Stop	Stop	Free	Free	Free	Free	Free	Free
RT Channelized	-	-	None	-	-	None	-	-	None	-	-	None
Storage Length	-	-	-	-	-	-	150	-	0	150	-	-
Veh in Median Storage, #	-	0	-	-	0	-	-	0	-	-	0	-
Grade, %	-	0	-	-	0	-	-	0	-	-	0	-
Peak Hour Factor	92	92	92	92	92	92	62	62	62	95	95	95
Heavy Vehicles, %	2	2	2	2	2	2	2	2	2	2	2	2
Mvmt Flow	16	0	11	0	0	0	35	494	0	0	205	27

Major/Minor	Minor2		Minor1		Major1		Major2					
Conflicting Flow All	783	783	219	788	796	494	232	0	0	494	0	0
Stage 1	219	219	-	564	564	-	-	-	-	-	-	-
Stage 2	564	564	-	224	232	-	-	-	-	-	-	-
Critical Hdwy	7.12	6.52	6.22	7.12	6.52	6.22	4.12	-	-	4.12	-	-
Critical Hdwy Stg 1	6.12	5.52	-	6.12	5.52	-	-	-	-	-	-	-
Critical Hdwy Stg 2	6.12	5.52	-	6.12	5.52	-	-	-	-	-	-	-
Follow-up Hdwy	3.518	4.018	3.318	3.518	4.018	3.318	2.218	-	-	2.218	-	-
Pot Cap-1 Maneuver	311	325	821	309	320	575	1336	-	-	1070	-	-
Stage 1	783	722	-	510	508	-	-	-	-	-	-	-
Stage 2	510	508	-	779	713	-	-	-	-	-	-	-
Platoon blocked, %								-	-	-	-	-
Mov Cap-1 Maneuver	305	317	821	299	312	575	1336	-	-	1070	-	-
Mov Cap-2 Maneuver	305	317	-	299	312	-	-	-	-	-	-	-
Stage 1	763	722	-	497	495	-	-	-	-	-	-	-
Stage 2	497	495	-	769	713	-	-	-	-	-	-	-

Approach	EB		WB		NB		SB	
HCM Control Delay, s	14.5		0		0.5		0	
HCM LOS	B		A					

Minor Lane/Major Mvmt	NBL	NBT	NBR	EBLn1WBLn1	SBL	SBT	SBR
Capacity (veh/h)	1336	-	-	407	-	1070	-
HCM Lane V/C Ratio	0.027	-	-	0.067	-	-	-
HCM Control Delay (s)	7.8	-	-	14.5	0	0	-
HCM Lane LOS	A	-	-	B	A	A	-
HCM 95th %tile Q(veh)	0.1	-	-	0.2	-	0	-

**Intersection**

Int Delay, s/veh	34.8					
<b>Movement</b>	<b>EBT</b>	<b>EBR</b>	<b>WBL</b>	<b>WBT</b>	<b>NBL</b>	<b>NBR</b>
Lane Configurations	↑↑↑	↑	↑	↑↑↑	↑	↑
Traffic Vol, veh/h	700	104	103	1600	101	163
Future Vol, veh/h	700	104	103	1600	101	163
Conflicting Peds, #/hr	0	0	0	0	0	0
Sign Control	Free	Free	Free	Free	Stop	Stop
RT Channelized	-	None	-	None	-	None
Storage Length	-	175	200	-	0	0
Veh in Median Storage, #	0	-	-	0	0	-
Grade, %	0	-	-	0	0	-
Peak Hour Factor	90	90	52	76	77	54
Heavy Vehicles, %	2	2	2	2	2	2
Mvmt Flow	778	116	198	2105	131	302

<b>Major/Minor</b>	<b>Major1</b>	<b>Major2</b>	<b>Minor1</b>		
Conflicting Flow All	0	0	894	0	2016 389
Stage 1	-	-	-	-	778 -
Stage 2	-	-	-	-	1238 -
Critical Hdwy	-	-	5.34	-	5.74 7.14
Critical Hdwy Stg 1	-	-	-	-	6.64 -
Critical Hdwy Stg 2	-	-	-	-	6.04 -
Follow-up Hdwy	-	-	3.12	-	3.82 3.92
Pot Cap-1 Maneuver	-	-	440	-	~ 92 521
Stage 1	-	-	-	-	330 -
Stage 2	-	-	-	-	212 -
Platoon blocked, %	-	-	-	-	-
Mov Cap-1 Maneuver	-	-	440	-	~ 51 521
Mov Cap-2 Maneuver	-	-	-	-	~ 51 -
Stage 1	-	-	-	-	182 -
Stage 2	-	-	-	-	212 -

<b>Approach</b>	<b>EB</b>	<b>WB</b>	<b>NB</b>
HCM Control Delay, s	0	1.7	282.4
HCM LOS			F

<b>Minor Lane/Major Mvmt</b>	<b>NBLn1</b>	<b>NBLn2</b>	<b>EBT</b>	<b>EBR</b>	<b>WBL</b>	<b>WBT</b>
Capacity (veh/h)	51	521	-	-	440	-
HCM Lane V/C Ratio	2.572	0.579	-	-	0.45	-
HCM Control Delay (s)	\$ 884	21	-	-	19.7	-
HCM Lane LOS	F	C	-	-	C	-
HCM 95th %tile Q(veh)	13.6	3.6	-	-	2.3	-

**Notes**

~: Volume exceeds capacity    \$: Delay exceeds 300s    +: Computation Not Defined    \*: All major volume in platoon



Intersection												
Int Delay, s/veh	0.5											
Movement	EBL	EBT	EBR	WBL	WBT	WBR	NBL	NBT	NBR	SBL	SBT	SBR
Lane Configurations			↗			↗		↑	↗	↖	↖	
Traffic Vol, veh/h	0	0	11	0	0	18	0	236	1	4	250	3
Future Vol, veh/h	0	0	11	0	0	18	0	236	1	4	250	3
Conflicting Peds, #/hr	0	0	0	0	0	0	0	0	0	0	0	0
Sign Control	Stop	Stop	Stop	Stop	Stop	Stop	Free	Free	Free	Free	Free	Free
RT Channelized	-	-	None	-	-	None	-	-	None	-	-	None
Storage Length	-	-	0	-	-	0	-	-	150	0	-	-
Veh in Median Storage, #	-	0	-	-	0	-	-	0	-	-	0	-
Grade, %	-	0	-	-	0	-	-	0	-	-	0	-
Peak Hour Factor	80	80	80	80	80	80	63	63	63	63	63	63
Heavy Vehicles, %	2	2	2	2	2	2	2	2	2	2	2	2
Mvmt Flow	0	0	14	0	0	23	0	375	2	6	397	5

Major/Minor	Minor2		Minor1		Major1		Major2					
Conflicting Flow All	-	-	400	-	-	375	-	0	0	377	0	0
Stage 1	-	-	-	-	-	-	-	-	-	-	-	-
Stage 2	-	-	-	-	-	-	-	-	-	-	-	-
Critical Hdwy	-	-	6.22	-	-	6.22	-	-	-	4.12	-	-
Critical Hdwy Stg 1	-	-	-	-	-	-	-	-	-	-	-	-
Critical Hdwy Stg 2	-	-	-	-	-	-	-	-	-	-	-	-
Follow-up Hdwy	-	-	3.318	-	-	3.318	-	-	-	2.218	-	-
Pot Cap-1 Maneuver	0	0	650	0	0	671	0	-	-	1181	-	-
Stage 1	0	0	-	0	0	-	0	-	-	-	-	-
Stage 2	0	0	-	0	0	-	0	-	-	-	-	-
Platoon blocked, %	-	-	-	-	-	-	-	-	-	-	-	-
Mov Cap-1 Maneuver	-	-	650	-	-	671	-	-	-	1181	-	-
Mov Cap-2 Maneuver	-	-	-	-	-	-	-	-	-	-	-	-
Stage 1	-	-	-	-	-	-	-	-	-	-	-	-
Stage 2	-	-	-	-	-	-	-	-	-	-	-	-

Approach	EB		WB		NB		SB	
HCM Control Delay, s	10.7		10.6		0		0.1	
HCM LOS	B		B					

Minor Lane/Major Mvmt	NBT	NBR	EBLn1WBLn1	SBL	SBT	SBR
Capacity (veh/h)	-	-	650	671	1181	-
HCM Lane V/C Ratio	-	-	0.021	0.034	0.005	-
HCM Control Delay (s)	-	-	10.7	10.6	8.1	-
HCM Lane LOS	-	-	B	B	A	-
HCM 95th %tile Q(veh)	-	-	0.1	0.1	0	-

Intersection												
Int Delay, s/veh	1.9											
Movement	EBL	EBT	EBR	WBL	WBT	WBR	NBL	NBT	NBR	SBL	SBT	SBR
Lane Configurations		↕			↕		↗	↑	↖	↗	↖	↖
Traffic Vol, veh/h	32	0	20	16	0	11	5	204	1	3	235	13
Future Vol, veh/h	32	0	20	16	0	11	5	204	1	3	235	13
Conflicting Peds, #/hr	0	0	0	0	0	0	0	0	0	0	0	0
Sign Control	Stop	Stop	Stop	Stop	Stop	Stop	Free	Free	Free	Free	Free	Free
RT Channelized	-	-	None	-	-	None	-	-	None	-	-	None
Storage Length	-	-	-	-	-	-	150	-	200	150	-	-
Veh in Median Storage, #	-	0	-	-	0	-	-	0	-	-	0	-
Grade, %	-	0	-	-	0	-	-	0	-	-	0	-
Peak Hour Factor	80	80	80	80	80	80	63	63	63	63	63	63
Heavy Vehicles, %	2	2	2	2	2	2	2	2	2	2	2	2
Mvmt Flow	40	0	25	20	0	14	8	324	2	5	373	21

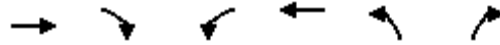
Major/Minor	Minor2		Minor1		Major1		Major2					
Conflicting Flow All	742	736	384	746	744	324	394	0	0	326	0	0
Stage 1	394	394	-	340	340	-	-	-	-	-	-	-
Stage 2	348	342	-	406	404	-	-	-	-	-	-	-
Critical Hdwy	7.12	6.52	6.22	7.12	6.52	6.22	4.12	-	-	4.12	-	-
Critical Hdwy Stg 1	6.12	5.52	-	6.12	5.52	-	-	-	-	-	-	-
Critical Hdwy Stg 2	6.12	5.52	-	6.12	5.52	-	-	-	-	-	-	-
Follow-up Hdwy	3.518	4.018	3.318	3.518	4.018	3.318	2.218	-	-	2.218	-	-
Pot Cap-1 Maneuver	332	346	664	330	343	717	1165	-	-	1234	-	-
Stage 1	631	605	-	675	639	-	-	-	-	-	-	-
Stage 2	668	638	-	622	599	-	-	-	-	-	-	-
Platoon blocked, %								-	-	-	-	-
Mov Cap-1 Maneuver	323	342	664	315	339	717	1165	-	-	1234	-	-
Mov Cap-2 Maneuver	323	342	-	315	339	-	-	-	-	-	-	-
Stage 1	627	603	-	670	635	-	-	-	-	-	-	-
Stage 2	651	634	-	596	597	-	-	-	-	-	-	-

Approach	EB		WB		NB		SB	
HCM Control Delay, s	15.6		14.6		0.2		0.1	
HCM LOS	C		B					

Minor Lane/Major Mvmt	NBL	NBT	NBR	EBLn1WBLn1	SBL	SBT	SBR
Capacity (veh/h)	1165	-	-	403	408	1234	-
HCM Lane V/C Ratio	0.007	-	-	0.161	0.083	0.004	-
HCM Control Delay (s)	8.1	-	-	15.6	14.6	7.9	-
HCM Lane LOS	A	-	-	C	B	A	-
HCM 95th %tile Q(veh)	0	-	-	0.6	0.3	0	-

Lanes, Volumes, Timings  
2: Akers Dr & N Carefree Cir

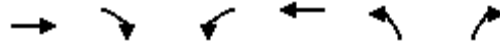
2040 Background + Site  
AM (Signalized)



Lane Group	EBT	EBR	WBL	WBT	NBL	NBR
Lane Configurations	↑↑↑	↗	↖	↑↑↑	↖	↗
Traffic Volume (vph)	700	104	103	1600	101	163
Future Volume (vph)	700	104	103	1600	101	163
Ideal Flow (vphp)	1900	1900	1900	1900	1900	1900
Storage Length (ft)		175	200		0	0
Storage Lanes		1	1		1	1
Taper Length (ft)			25		25	
Lane Util. Factor	0.91	1.00	1.00	0.91	1.00	1.00
Frt		0.850				0.850
Flt Protected			0.950		0.950	
Satd. Flow (prot)	5085	1583	1770	5085	1770	1583
Flt Permitted			0.360		0.950	
Satd. Flow (perm)	5085	1583	671	5085	1770	1583
Right Turn on Red		Yes				Yes
Satd. Flow (RTOR)		109				183
Link Speed (mph)	40			40	35	
Link Distance (ft)	1193			905	411	
Travel Time (s)	20.3			15.4	8.0	
Peak Hour Factor	0.95	0.95	0.70	0.90	0.85	0.70
Adj. Flow (vph)	737	109	147	1778	119	233
Shared Lane Traffic (%)						
Lane Group Flow (vph)	737	109	147	1778	119	233
Enter Blocked Intersection	No	No	No	No	No	No
Lane Alignment	Left	Right	Left	Left	Left	Right
Median Width(ft)	12			12	12	
Link Offset(ft)	0			0	0	
Crosswalk Width(ft)	16			16	16	
Two way Left Turn Lane						
Headway Factor	1.00	1.00	1.00	1.00	1.00	1.00
Turning Speed (mph)		9	15		15	9
Number of Detectors	2	1	1	2	1	1
Detector Template	Thru	Right	Left	Thru	Left	Right
Leading Detector (ft)	100	20	20	100	20	20
Trailing Detector (ft)	0	0	0	0	0	0
Detector 1 Position(ft)	0	0	0	0	0	0
Detector 1 Size(ft)	6	20	20	6	20	20
Detector 1 Type	Cl+Ex	Cl+Ex	Cl+Ex	Cl+Ex	Cl+Ex	Cl+Ex
Detector 1 Channel						
Detector 1 Extend (s)	0.0	0.0	0.0	0.0	0.0	0.0
Detector 1 Queue (s)	0.0	0.0	0.0	0.0	0.0	0.0
Detector 1 Delay (s)	0.0	0.0	0.0	0.0	0.0	0.0
Detector 2 Position(ft)	94			94		
Detector 2 Size(ft)	6			6		
Detector 2 Type	Cl+Ex			Cl+Ex		
Detector 2 Channel						
Detector 2 Extend (s)	0.0			0.0		
Turn Type	NA	Perm	Perm	NA	Prot	Perm
Protected Phases	4			8	2	
Permitted Phases		4	8			2

Lanes, Volumes, Timings  
2: Akers Dr & N Carefree Cir

2040 Background + Site  
AM (Signalized)

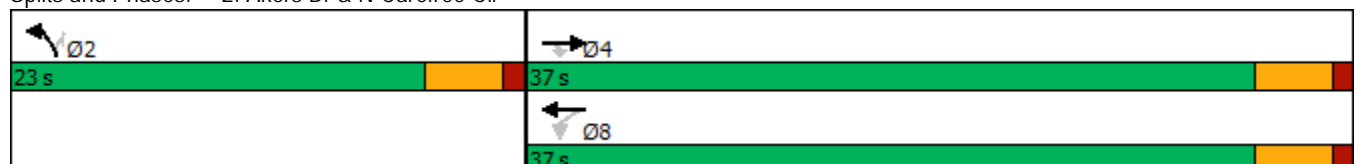


Lane Group	EBT	EBR	WBL	WBT	NBL	NBR
Detector Phase	4	4	8	8	2	2
Switch Phase						
Minimum Initial (s)	5.0	5.0	5.0	5.0	5.0	5.0
Minimum Split (s)	22.5	22.5	22.5	22.5	22.5	22.5
Total Split (s)	37.0	37.0	37.0	37.0	23.0	23.0
Total Split (%)	61.7%	61.7%	61.7%	61.7%	38.3%	38.3%
Maximum Green (s)	32.5	32.5	32.5	32.5	18.5	18.5
Yellow Time (s)	3.5	3.5	3.5	3.5	3.5	3.5
All-Red Time (s)	1.0	1.0	1.0	1.0	1.0	1.0
Lost Time Adjust (s)	0.0	0.0	0.0	0.0	0.0	0.0
Total Lost Time (s)	4.5	4.5	4.5	4.5	4.5	4.5
Lead/Lag						
Lead-Lag Optimize?						
Vehicle Extension (s)	3.0	3.0	3.0	3.0	3.0	3.0
Recall Mode	None	None	None	None	Min	Min
Walk Time (s)	7.0	7.0	7.0	7.0	7.0	7.0
Flash Dont Walk (s)	11.0	11.0	11.0	11.0	11.0	11.0
Pedestrian Calls (#/hr)	0	0	0	0	0	0
Act Effct Green (s)	28.3	28.3	28.3	28.3	8.8	8.8
Actuated g/C Ratio	0.61	0.61	0.61	0.61	0.19	0.19
v/c Ratio	0.24	0.11	0.36	0.57	0.36	0.52
Control Delay	4.4	1.5	8.0	6.4	20.9	10.4
Queue Delay	0.0	0.0	0.0	0.0	0.0	0.0
Total Delay	4.4	1.5	8.0	6.4	20.9	10.4
LOS	A	A	A	A	C	B
Approach Delay	4.0			6.5	14.0	
Approach LOS	A			A	B	

Intersection Summary

Area Type:	Other
Cycle Length:	60
Actuated Cycle Length:	46.4
Natural Cycle:	50
Control Type:	Actuated-Uncoordinated
Maximum v/c Ratio:	0.57
Intersection Signal Delay:	6.7
Intersection LOS:	A
Intersection Capacity Utilization:	44.0%
ICU Level of Service:	A
Analysis Period (min):	15

Splits and Phases: 2: Akers Dr & N Carefree Cir



Intersection												
Int Delay, s/veh	0.6											
Movement	EBL	EBT	EBR	WBL	WBT	WBR	NBL	NBT	NBR	SBL	SBT	SBR
Lane Configurations			↗			↗		↑	↗	↖	↖	
Traffic Vol, veh/h	0	0	11	0	0	18	0	236	1	4	250	3
Future Vol, veh/h	0	0	11	0	0	18	0	236	1	4	250	3
Conflicting Peds, #/hr	0	0	0	0	0	0	0	0	0	0	0	0
Sign Control	Stop	Stop	Stop	Stop	Stop	Stop	Free	Free	Free	Free	Free	Free
RT Channelized	-	-	None	-	-	None	-	-	None	-	-	None
Storage Length	-	-	0	-	-	0	-	-	150	0	-	-
Veh in Median Storage, #	-	0	-	-	0	-	-	0	-	-	0	-
Grade, %	-	0	-	-	0	-	-	0	-	-	0	-
Peak Hour Factor	80	80	80	80	80	80	80	80	80	80	80	80
Heavy Vehicles, %	2	2	2	2	2	2	2	2	2	2	2	2
Mvmt Flow	0	0	14	0	0	23	0	295	1	5	313	4

Major/Minor	Minor2		Minor1		Major1		Major2					
Conflicting Flow All	-	-	315	-	-	295	-	0	0	296	0	0
Stage 1	-	-	-	-	-	-	-	-	-	-	-	-
Stage 2	-	-	-	-	-	-	-	-	-	-	-	-
Critical Hdwy	-	-	6.22	-	-	6.22	-	-	-	4.12	-	-
Critical Hdwy Stg 1	-	-	-	-	-	-	-	-	-	-	-	-
Critical Hdwy Stg 2	-	-	-	-	-	-	-	-	-	-	-	-
Follow-up Hdwy	-	-	3.318	-	-	3.318	-	-	-	2.218	-	-
Pot Cap-1 Maneuver	0	0	725	0	0	744	0	-	-	1265	-	-
Stage 1	0	0	-	0	0	-	0	-	-	-	-	-
Stage 2	0	0	-	0	0	-	0	-	-	-	-	-
Platoon blocked, %	-	-	-	-	-	-	-	-	-	-	-	-
Mov Cap-1 Maneuver	-	-	725	-	-	744	-	-	-	1265	-	-
Mov Cap-2 Maneuver	-	-	-	-	-	-	-	-	-	-	-	-
Stage 1	-	-	-	-	-	-	-	-	-	-	-	-
Stage 2	-	-	-	-	-	-	-	-	-	-	-	-

Approach	EB		WB		NB		SB	
HCM Control Delay, s	10.1		10		0		0.1	
HCM LOS	B		B					

Minor Lane/Major Mvmt	NBT	NBR	EBLn1WBLn1	SBL	SBT	SBR
Capacity (veh/h)	-	-	725	744	1265	-
HCM Lane V/C Ratio	-	-	0.019	0.03	0.004	-
HCM Control Delay (s)	-	-	10.1	10	7.9	-
HCM Lane LOS	-	-	B	B	A	-
HCM 95th %tile Q(veh)	-	-	0.1	0.1	0	-

Intersection												
Int Delay, s/veh	2											
Movement	EBL	EBT	EBR	WBL	WBT	WBR	NBL	NBT	NBR	SBL	SBT	SBR
Lane Configurations		↕			↕		↗	↖	↗	↖	↖	↗
Traffic Vol, veh/h	32	0	20	16	0	11	5	204	1	3	235	13
Future Vol, veh/h	32	0	20	16	0	11	5	204	1	3	235	13
Conflicting Peds, #/hr	0	0	0	0	0	0	0	0	0	0	0	0
Sign Control	Stop	Stop	Stop	Stop	Stop	Stop	Free	Free	Free	Free	Free	Free
RT Channelized	-	-	None	-	-	None	-	-	None	-	-	None
Storage Length	-	-	-	-	-	-	150	-	300	150	-	-
Veh in Median Storage, #	-	0	-	-	0	-	-	0	-	-	0	-
Grade, %	-	0	-	-	0	-	-	0	-	-	0	-
Peak Hour Factor	80	80	80	80	80	80	80	80	80	80	80	80
Heavy Vehicles, %	2	2	2	2	2	2	2	2	2	2	2	2
Mvmt Flow	40	0	25	20	0	14	6	255	1	4	294	16

Major/Minor	Minor2		Minor1		Major1			Major2				
Conflicting Flow All	585	578	302	590	585	255	310	0	0	256	0	0
Stage 1	310	310	-	267	267	-	-	-	-	-	-	-
Stage 2	275	268	-	323	318	-	-	-	-	-	-	-
Critical Hdwy	7.12	6.52	6.22	7.12	6.52	6.22	4.12	-	-	4.12	-	-
Critical Hdwy Stg 1	6.12	5.52	-	6.12	5.52	-	-	-	-	-	-	-
Critical Hdwy Stg 2	6.12	5.52	-	6.12	5.52	-	-	-	-	-	-	-
Follow-up Hdwy	3.518	4.018	3.318	3.518	4.018	3.318	2.218	-	-	2.218	-	-
Pot Cap-1 Maneuver	422	427	738	419	423	784	1250	-	-	1309	-	-
Stage 1	700	659	-	738	688	-	-	-	-	-	-	-
Stage 2	731	687	-	689	654	-	-	-	-	-	-	-
Platoon blocked, %								-	-	-	-	-
Mov Cap-1 Maneuver	412	424	738	402	420	784	1250	-	-	1309	-	-
Mov Cap-2 Maneuver	412	424	-	402	420	-	-	-	-	-	-	-
Stage 1	697	657	-	734	685	-	-	-	-	-	-	-
Stage 2	715	684	-	664	652	-	-	-	-	-	-	-

Approach	EB	WB	NB	SB
HCM Control Delay, s	13.4	12.7	0.2	0.1
HCM LOS	B	B		

Minor Lane/Major Mvmt	NBL	NBT	NBR	EBLn1WBLn1	SBL	SBT	SBR
Capacity (veh/h)	1250	-	-	496	502	1309	-
HCM Lane V/C Ratio	0.005	-	-	0.131	0.067	0.003	-
HCM Control Delay (s)	7.9	-	-	13.4	12.7	7.8	-
HCM Lane LOS	A	-	-	B	B	A	-
HCM 95th %tile Q(veh)	0	-	-	0.4	0.2	0	-

**Intersection**

Int Delay, s/veh 1153.8

Movement	EBT	EBR	WBL	WBT	NBL	NBR
Lane Configurations	↑↑↑	↗	↘	↑↑↑	↘	↗
Traffic Vol, veh/h	1475	140	111	1250	158	179
Future Vol, veh/h	1475	140	111	1250	158	179
Conflicting Peds, #/hr	0	0	0	0	0	0
Sign Control	Free	Free	Free	Free	Stop	Stop
RT Channelized	-	None	-	None	-	None
Storage Length	-	175	200	-	0	0
Veh in Median Storage, #	0	-	-	0	0	-
Grade, %	0	-	-	0	0	-
Peak Hour Factor	91	91	80	80	60	60
Heavy Vehicles, %	2	2	2	2	2	2
Mvmt Flow	1621	154	139	1563	263	298

**Major/Minor**

	Major1	Major2	Minor1		
Conflicting Flow All	0	0	1775	0	2524
Stage 1	-	-	-	-	1621
Stage 2	-	-	-	-	903
Critical Hdwy	-	-	5.34	-	5.74
Critical Hdwy Stg 1	-	-	-	-	6.64
Critical Hdwy Stg 2	-	-	-	-	6.04
Follow-up Hdwy	-	-	3.12	-	3.82
Pot Cap-1 Maneuver	-	-	162	-	~ 48
Stage 1	-	-	-	-	~ 99
Stage 2	-	-	-	-	322
Platoon blocked, %	-	-	-	-	-
Mov Cap-1 Maneuver	-	-	162	-	~ 7
Mov Cap-2 Maneuver	-	-	-	-	~ 7
Stage 1	-	-	-	-	~ 14
Stage 2	-	-	-	-	322

**Approach**

	EB	WB	NB
HCM Control Delay, s	0	7.6	\$ 8271.5
HCM LOS			F

**Minor Lane/Major Mvmt**

	NBLn1	NBLn2	EBT	EBR	WBL	WBT
Capacity (veh/h)	7	277	-	-	162	-
HCM Lane V/C Ratio	37.619	1.077	-	-	0.856	-
HCM Control Delay (s)	\$ 17510.3	116.6	-	-	92.9	-
HCM Lane LOS	F	F	-	-	F	-
HCM 95th %tile Q(veh)	34.9	12	-	-	5.9	-

**Notes**

~: Volume exceeds capacity    \$: Delay exceeds 300s    +: Computation Not Defined    \*: All major volume in platoon

Intersection												
Int Delay, s/veh	0.4											
Movement	EBL	EBT	EBR	WBL	WBT	WBR	NBL	NBT	NBR	SBL	SBT	SBR
Lane Configurations			↗			↗		↑	↗	↖	↖	
Traffic Vol, veh/h	0	0	8	0	0	8	0	324	9	15	229	7
Future Vol, veh/h	0	0	8	0	0	8	0	324	9	15	229	7
Conflicting Peds, #/hr	0	0	0	0	0	0	0	0	0	0	0	0
Sign Control	Stop	Stop	Stop	Stop	Stop	Stop	Free	Free	Free	Free	Free	Free
RT Channelized	-	-	None	-	-	None	-	-	None	-	-	None
Storage Length	-	-	0	-	-	0	-	-	150	0	-	-
Veh in Median Storage, #	-	0	-	-	0	-	-	0	-	-	0	-
Grade, %	-	0	-	-	0	-	-	0	-	-	0	-
Peak Hour Factor	92	92	92	92	92	92	62	62	62	95	95	95
Heavy Vehicles, %	2	2	2	2	2	2	2	2	2	2	2	2
Mvmt Flow	0	0	9	0	0	9	0	523	15	16	241	7

Major/Minor	Minor2		Minor1		Major1		Major2					
Conflicting Flow All	-	-	245	-	-	523	-	0	0	538	0	0
Stage 1	-	-	-	-	-	-	-	-	-	-	-	-
Stage 2	-	-	-	-	-	-	-	-	-	-	-	-
Critical Hdwy	-	-	6.22	-	-	6.22	-	-	-	4.12	-	-
Critical Hdwy Stg 1	-	-	-	-	-	-	-	-	-	-	-	-
Critical Hdwy Stg 2	-	-	-	-	-	-	-	-	-	-	-	-
Follow-up Hdwy	-	-	3.318	-	-	3.318	-	-	-	2.218	-	-
Pot Cap-1 Maneuver	0	0	794	0	0	554	0	-	-	1030	-	-
Stage 1	0	0	-	0	0	-	0	-	-	-	-	-
Stage 2	0	0	-	0	0	-	0	-	-	-	-	-
Platoon blocked, %	-	-	-	-	-	-	-	-	-	-	-	-
Mov Cap-1 Maneuver	-	-	794	-	-	554	-	-	-	1030	-	-
Mov Cap-2 Maneuver	-	-	-	-	-	-	-	-	-	-	-	-
Stage 1	-	-	-	-	-	-	-	-	-	-	-	-
Stage 2	-	-	-	-	-	-	-	-	-	-	-	-

Approach	EB		WB		NB		SB	
HCM Control Delay, s	9.6		11.6		0		0.5	
HCM LOS	A		B					

Minor Lane/Major Mvmt	NBT	NBR	EBLn1WBLn1	SBL	SBT	SBR
Capacity (veh/h)	-	-	794	554	1030	-
HCM Lane V/C Ratio	-	-	0.011	0.016	0.015	-
HCM Control Delay (s)	-	-	9.6	11.6	8.6	-
HCM Lane LOS	-	-	A	B	A	-
HCM 95th %tile Q(veh)	-	-	0	0	0	-



Intersection												
Int Delay, s/veh	1.5											
Movement	EBL	EBT	EBR	WBL	WBT	WBR	NBL	NBT	NBR	SBL	SBT	SBR
Lane Configurations		↕			↕		↕	↑	↑	↕	↕	↕
Traffic Vol, veh/h	15	0	10	19	0	4	23	315	8	11	195	26
Future Vol, veh/h	15	0	10	19	0	4	23	315	8	11	195	26
Conflicting Peds, #/hr	0	0	0	0	0	0	0	0	0	0	0	0
Sign Control	Stop	Stop	Stop	Stop	Stop	Stop	Free	Free	Free	Free	Free	Free
RT Channelized	-	-	None	-	-	None	-	-	None	-	-	None
Storage Length	-	-	-	-	-	-	150	-	0	150	-	-
Veh in Median Storage, #	-	0	-	-	0	-	-	0	-	-	0	-
Grade, %	-	0	-	-	0	-	-	0	-	-	0	-
Peak Hour Factor	92	92	92	92	92	92	62	62	62	95	95	95
Heavy Vehicles, %	2	2	2	2	2	2	2	2	2	2	2	2
Mvmt Flow	16	0	11	21	0	4	37	508	13	12	205	27

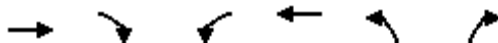
Major/Minor	Minor2		Minor1		Major1			Major2				
Conflicting Flow All	834	838	219	830	838	508	232	0	0	521	0	0
Stage 1	243	243	-	582	582	-	-	-	-	-	-	-
Stage 2	591	595	-	248	256	-	-	-	-	-	-	-
Critical Hdwy	7.12	6.52	6.22	7.12	6.52	6.22	4.12	-	-	4.12	-	-
Critical Hdwy Stg 1	6.12	5.52	-	6.12	5.52	-	-	-	-	-	-	-
Critical Hdwy Stg 2	6.12	5.52	-	6.12	5.52	-	-	-	-	-	-	-
Follow-up Hdwy	3.518	4.018	3.318	3.518	4.018	3.318	2.218	-	-	2.218	-	-
Pot Cap-1 Maneuver	288	302	821	289	302	565	1336	-	-	1045	-	-
Stage 1	761	705	-	499	499	-	-	-	-	-	-	-
Stage 2	493	492	-	756	696	-	-	-	-	-	-	-
Platoon blocked, %								-	-	-	-	-
Mov Cap-1 Maneuver	277	290	821	277	290	565	1336	-	-	1045	-	-
Mov Cap-2 Maneuver	277	290	-	277	290	-	-	-	-	-	-	-
Stage 1	740	697	-	485	485	-	-	-	-	-	-	-
Stage 2	476	478	-	737	688	-	-	-	-	-	-	-

Approach	EB		WB		NB		SB	
HCM Control Delay, s	15.3		17.9		0.5		0.4	
HCM LOS	C		C					

Minor Lane/Major Mvmt	NBL	NBT	NBR	EBLn1WBLn1	SBL	SBT	SBR
Capacity (veh/h)	1336	-	-	377	304	1045	-
HCM Lane V/C Ratio	0.028	-	-	0.072	0.082	0.011	-
HCM Control Delay (s)	7.8	-	-	15.3	17.9	8.5	-
HCM Lane LOS	A	-	-	C	C	A	-
HCM 95th %tile Q(veh)	0.1	-	-	0.2	0.3	0	-

Lanes, Volumes, Timings  
2: Akers Dr & N Carefree Cir

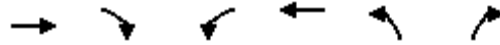
2040 Background + Site  
PM (Signalized)



Lane Group	EBT	EBR	WBL	WBT	NBL	NBR
Lane Configurations	↑↑↑	↗	↖	↑↑↑	↖	↗
Traffic Volume (vph)	1475	140	111	1250	158	179
Future Volume (vph)	1475	140	111	1250	158	179
Ideal Flow (vphp)	1900	1900	1900	1900	1900	1900
Storage Length (ft)		175	200		0	0
Storage Lanes		1	1		1	1
Taper Length (ft)			25		25	
Lane Util. Factor	0.91	1.00	1.00	0.91	1.00	1.00
Frt		0.850				0.850
Flt Protected			0.950		0.950	
Satd. Flow (prot)	5085	1583	1770	5085	1770	1583
Flt Permitted			0.154		0.950	
Satd. Flow (perm)	5085	1583	287	5085	1770	1583
Right Turn on Red		Yes				Yes
Satd. Flow (RTOR)		147				195
Link Speed (mph)	40			40	35	
Link Distance (ft)	1193			905	411	
Travel Time (s)	20.3			15.4	8.0	
Peak Hour Factor	0.95	0.95	0.92	0.92	0.92	0.92
Adj. Flow (vph)	1553	147	121	1359	172	195
Shared Lane Traffic (%)						
Lane Group Flow (vph)	1553	147	121	1359	172	195
Enter Blocked Intersection	No	No	No	No	No	No
Lane Alignment	Left	Right	Left	Left	Left	Right
Median Width(ft)	12			12	12	
Link Offset(ft)	0			0	0	
Crosswalk Width(ft)	16			16	16	
Two way Left Turn Lane						
Headway Factor	1.00	1.00	1.00	1.00	1.00	1.00
Turning Speed (mph)		9	15		15	9
Number of Detectors	2	1	1	2	1	1
Detector Template	Thru	Right	Left	Thru	Left	Right
Leading Detector (ft)	100	20	20	100	20	20
Trailing Detector (ft)	0	0	0	0	0	0
Detector 1 Position(ft)	0	0	0	0	0	0
Detector 1 Size(ft)	6	20	20	6	20	20
Detector 1 Type	Cl+Ex	Cl+Ex	Cl+Ex	Cl+Ex	Cl+Ex	Cl+Ex
Detector 1 Channel						
Detector 1 Extend (s)	0.0	0.0	0.0	0.0	0.0	0.0
Detector 1 Queue (s)	0.0	0.0	0.0	0.0	0.0	0.0
Detector 1 Delay (s)	0.0	0.0	0.0	0.0	0.0	0.0
Detector 2 Position(ft)	94			94		
Detector 2 Size(ft)	6			6		
Detector 2 Type	Cl+Ex			Cl+Ex		
Detector 2 Channel						
Detector 2 Extend (s)	0.0			0.0		
Turn Type	NA	Perm	pm+pt	NA	Prot	Perm
Protected Phases	4		3	8	2	
Permitted Phases		4	8			2

Lanes, Volumes, Timings  
2: Akers Dr & N Carefree Cir

2040 Background + Site  
PM (Signalized)

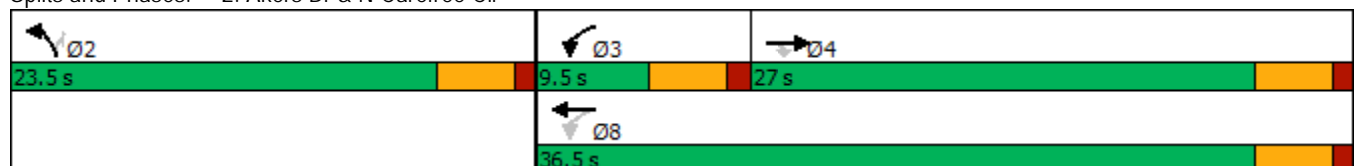


Lane Group	EBT	EBR	WBL	WBT	NBL	NBR
Detector Phase	4	4	3	8	2	2
Switch Phase						
Minimum Initial (s)	5.0	5.0	5.0	5.0	5.0	5.0
Minimum Split (s)	22.5	22.5	9.5	22.5	22.5	22.5
Total Split (s)	27.0	27.0	9.5	36.5	23.5	23.5
Total Split (%)	45.0%	45.0%	15.8%	60.8%	39.2%	39.2%
Maximum Green (s)	22.5	22.5	5.0	32.0	19.0	19.0
Yellow Time (s)	3.5	3.5	3.5	3.5	3.5	3.5
All-Red Time (s)	1.0	1.0	1.0	1.0	1.0	1.0
Lost Time Adjust (s)	0.0	0.0	0.0	0.0	0.0	0.0
Total Lost Time (s)	4.5	4.5	4.5	4.5	4.5	4.5
Lead/Lag	Lag	Lag	Lead			
Lead-Lag Optimize?	Yes	Yes	Yes			
Vehicle Extension (s)	3.0	3.0	3.0	3.0	3.0	3.0
Recall Mode	None	None	None	None	Min	Min
Walk Time (s)	7.0	7.0		7.0	7.0	7.0
Flash Dont Walk (s)	11.0	11.0		11.0	11.0	11.0
Pedestrian Calls (#/hr)	0	0		0	0	0
Act Effct Green (s)	21.5	21.5	28.5	28.5	10.1	10.1
Actuated g/C Ratio	0.45	0.45	0.59	0.59	0.21	0.21
v/c Ratio	0.68	0.19	0.37	0.45	0.46	0.40
Control Delay	13.5	3.1	7.8	6.1	22.2	6.1
Queue Delay	0.0	0.0	0.0	0.0	0.0	0.0
Total Delay	13.5	3.1	7.8	6.1	22.2	6.1
LOS	B	A	A	A	C	A
Approach Delay	12.6			6.2	13.6	
Approach LOS	B			A	B	

Intersection Summary

Area Type:	Other
Cycle Length:	60
Actuated Cycle Length:	48
Natural Cycle:	60
Control Type:	Actuated-Uncoordinated
Maximum v/c Ratio:	0.68
Intersection Signal Delay:	10.0
Intersection LOS:	B
Intersection Capacity Utilization:	54.7%
ICU Level of Service:	A
Analysis Period (min):	15

Splits and Phases: 2: Akers Dr & N Carefree Cir



Intersection												
Int Delay, s/veh	0.5											
Movement	EBL	EBT	EBR	WBL	WBT	WBR	NBL	NBT	NBR	SBL	SBT	SBR
Lane Configurations			↗			↗		↑	↗	↖	↖	
Traffic Vol, veh/h	0	0	8	0	0	8	0	325	9	15	229	7
Future Vol, veh/h	0	0	8	0	0	8	0	325	9	15	229	7
Conflicting Peds, #/hr	0	0	0	0	0	0	0	0	0	0	0	0
Sign Control	Stop	Stop	Stop	Stop	Stop	Stop	Free	Free	Free	Free	Free	Free
RT Channelized	-	-	None	-	-	None	-	-	None	-	-	None
Storage Length	-	-	0	-	-	0	-	-	150	0	-	-
Veh in Median Storage, #	-	0	-	-	0	-	-	0	-	-	0	-
Grade, %	-	0	-	-	0	-	-	0	-	-	0	-
Peak Hour Factor	92	92	92	92	92	92	92	92	92	95	95	95
Heavy Vehicles, %	2	2	2	2	2	2	2	2	2	2	2	2
Mvmt Flow	0	0	9	0	0	9	0	353	10	16	241	7

Major/Minor	Minor2		Minor1		Major1		Major2					
Conflicting Flow All	-	-	245	-	-	353	-	0	0	363	0	0
Stage 1	-	-	-	-	-	-	-	-	-	-	-	-
Stage 2	-	-	-	-	-	-	-	-	-	-	-	-
Critical Hdwy	-	-	6.22	-	-	6.22	-	-	-	4.12	-	-
Critical Hdwy Stg 1	-	-	-	-	-	-	-	-	-	-	-	-
Critical Hdwy Stg 2	-	-	-	-	-	-	-	-	-	-	-	-
Follow-up Hdwy	-	-	3.318	-	-	3.318	-	-	-	2.218	-	-
Pot Cap-1 Maneuver	0	0	794	0	0	691	0	-	-	1196	-	-
Stage 1	0	0	-	0	0	-	0	-	-	-	-	-
Stage 2	0	0	-	0	0	-	0	-	-	-	-	-
Platoon blocked, %	-	-	-	-	-	-	-	-	-	-	-	-
Mov Cap-1 Maneuver	-	-	794	-	-	691	-	-	-	1196	-	-
Mov Cap-2 Maneuver	-	-	-	-	-	-	-	-	-	-	-	-
Stage 1	-	-	-	-	-	-	-	-	-	-	-	-
Stage 2	-	-	-	-	-	-	-	-	-	-	-	-

Approach	EB		WB		NB		SB	
HCM Control Delay, s	9.6		10.3		0		0.5	
HCM LOS	A		B					

Minor Lane/Major Mvmt	NBT	NBR	EBLn1WBLn1	SBL	SBT	SBR
Capacity (veh/h)	-	-	794	691	1196	-
HCM Lane V/C Ratio	-	-	0.011	0.013	0.013	-
HCM Control Delay (s)	-	-	9.6	10.3	8.1	-
HCM Lane LOS	-	-	A	B	A	-
HCM 95th %tile Q(veh)	-	-	0	0	0	-

Intersection												
Int Delay, s/veh	1.5											
Movement	EBL	EBT	EBR	WBL	WBT	WBR	NBL	NBT	NBR	SBL	SBT	SBR
Lane Configurations		↕			↕		↗	↑	↖	↗	↖	↖
Traffic Vol, veh/h	15	0	10	19	0	4	23	315	8	11	195	26
Future Vol, veh/h	15	0	10	19	0	4	23	315	8	11	195	26
Conflicting Peds, #/hr	0	0	0	0	0	0	0	0	0	0	0	0
Sign Control	Stop	Stop	Stop	Stop	Stop	Stop	Free	Free	Free	Free	Free	Free
RT Channelized	-	-	None	-	-	None	-	-	None	-	-	None
Storage Length	-	-	-	-	-	-	150	-	300	150	-	-
Veh in Median Storage, #	-	0	-	-	0	-	-	0	-	-	0	-
Grade, %	-	0	-	-	0	-	-	0	-	-	0	-
Peak Hour Factor	92	92	92	92	92	92	92	92	92	95	95	95
Heavy Vehicles, %	2	2	2	2	2	2	2	2	2	2	2	2
Mvmt Flow	16	0	11	21	0	4	25	342	9	12	205	27

Major/Minor	Minor2		Minor1		Major1		Major2					
Conflicting Flow All	642	644	219	640	648	342	232	0	0	351	0	0
Stage 1	243	243	-	392	392	-	-	-	-	-	-	-
Stage 2	399	401	-	248	256	-	-	-	-	-	-	-
Critical Hdwy	7.12	6.52	6.22	7.12	6.52	6.22	4.12	-	-	4.12	-	-
Critical Hdwy Stg 1	6.12	5.52	-	6.12	5.52	-	-	-	-	-	-	-
Critical Hdwy Stg 2	6.12	5.52	-	6.12	5.52	-	-	-	-	-	-	-
Follow-up Hdwy	3.518	4.018	3.318	3.518	4.018	3.318	2.218	-	-	2.218	-	-
Pot Cap-1 Maneuver	387	391	821	388	389	701	1336	-	-	1208	-	-
Stage 1	761	705	-	633	606	-	-	-	-	-	-	-
Stage 2	627	601	-	756	696	-	-	-	-	-	-	-
Platoon blocked, %								-	-	-	-	-
Mov Cap-1 Maneuver	376	380	821	374	378	701	1336	-	-	1208	-	-
Mov Cap-2 Maneuver	376	380	-	374	378	-	-	-	-	-	-	-
Stage 1	747	698	-	621	594	-	-	-	-	-	-	-
Stage 2	611	590	-	739	689	-	-	-	-	-	-	-

Approach	EB		WB		NB		SB	
HCM Control Delay, s	13		14.4		0.5		0.4	
HCM LOS	B		B					

Minor Lane/Major Mvmt	NBL	NBT	NBR	EBLn1WBLn1	SBL	SBT	SBR
Capacity (veh/h)	1336	-	-	480	407	1208	-
HCM Lane V/C Ratio	0.019	-	-	0.057	0.061	0.01	-
HCM Control Delay (s)	7.7	-	-	13	14.4	8	-
HCM Lane LOS	A	-	-	B	B	A	-
HCM 95th %tile Q(veh)	0.1	-	-	0.2	0.2	0	-

**Intersection: 2: Akers Dr & N Carefree Cir, Interval #1**

Movement	WB	NB	NB
Directions Served	L	L	R
Maximum Queue (ft)	32	64	19
Average Queue (ft)	28	32	15
95th Queue (ft)	31	65	25
Link Distance (ft)		310	310
Upstream Blk Time (%)			
Queuing Penalty (veh)			
Storage Bay Dist (ft)	200		
Storage Blk Time (%)			
Queuing Penalty (veh)			

**Intersection: 2: Akers Dr & N Carefree Cir, Interval #2**

Movement	WB	NB	NB
Directions Served	L	L	R
Maximum Queue (ft)	30	46	19
Average Queue (ft)	20	25	14
95th Queue (ft)	41	49	24
Link Distance (ft)		310	310
Upstream Blk Time (%)			
Queuing Penalty (veh)			
Storage Bay Dist (ft)	200		
Storage Blk Time (%)			
Queuing Penalty (veh)			

**Intersection: 2: Akers Dr & N Carefree Cir, Interval #3**

Movement	WB	NB	NB
Directions Served	L	L	R
Maximum Queue (ft)	174	132	79
Average Queue (ft)	69	56	38
95th Queue (ft)	153	130	71
Link Distance (ft)		310	310
Upstream Blk Time (%)			
Queuing Penalty (veh)			
Storage Bay Dist (ft)	200		
Storage Blk Time (%)			
Queuing Penalty (veh)			

**Intersection: 2: Akers Dr & N Carefree Cir, Interval #4**

Movement	WB	NB	NB
Directions Served	L	L	R
Maximum Queue (ft)	31	44	19
Average Queue (ft)	12	23	14
95th Queue (ft)	36	48	25
Link Distance (ft)		310	310
Upstream Blk Time (%)			
Queuing Penalty (veh)			
Storage Bay Dist (ft)	200		
Storage Blk Time (%)			
Queuing Penalty (veh)			

**Intersection: 2: Akers Dr & N Carefree Cir, All Intervals**

Movement	WB	NB	NB
Directions Served	L	L	R
Maximum Queue (ft)	174	132	79
Average Queue (ft)	32	34	20
95th Queue (ft)	90	83	46
Link Distance (ft)		310	310
Upstream Blk Time (%)			
Queuing Penalty (veh)			
Storage Bay Dist (ft)	200		
Storage Blk Time (%)			
Queuing Penalty (veh)			

**Intersection: 2: Akers Dr & N Carefree Cir, Interval #1**

Movement	WB	NB	NB
Directions Served	L	L	R
Maximum Queue (ft)	26	41	17
Average Queue (ft)	4	23	6
95th Queue (ft)	19	35	19
Link Distance (ft)		310	310
Upstream Blk Time (%)			
Queuing Penalty (veh)			
Storage Bay Dist (ft)	200		
Storage Blk Time (%)			
Queuing Penalty (veh)			

**Intersection: 2: Akers Dr & N Carefree Cir, Interval #2**

Movement	WB	NB	NB
Directions Served	L	L	R
Maximum Queue (ft)	28	46	17
Average Queue (ft)	11	26	9
95th Queue (ft)	33	49	22
Link Distance (ft)		310	310
Upstream Blk Time (%)			
Queuing Penalty (veh)			
Storage Bay Dist (ft)	200		
Storage Blk Time (%)			
Queuing Penalty (veh)			

**Intersection: 2: Akers Dr & N Carefree Cir, Interval #3**

Movement	WB	NB	NB
Directions Served	L	L	R
Maximum Queue (ft)	29	87	19
Average Queue (ft)	12	65	18
95th Queue (ft)	36	102	20
Link Distance (ft)		310	310
Upstream Blk Time (%)			
Queuing Penalty (veh)			
Storage Bay Dist (ft)	200		
Storage Blk Time (%)			
Queuing Penalty (veh)			



**Intersection: 2: Akers Dr & N Carefree Cir, Interval #4**

Movement	WB	NB	NB
Directions Served	L	L	R
Maximum Queue (ft)	29	44	17
Average Queue (ft)	4	12	9
95th Queue (ft)	21	38	22
Link Distance (ft)		310	310
Upstream Blk Time (%)			
Queuing Penalty (veh)			
Storage Bay Dist (ft)	200		
Storage Blk Time (%)			
Queuing Penalty (veh)			

**Intersection: 2: Akers Dr & N Carefree Cir, All Intervals**

Movement	WB	NB	NB
Directions Served	L	L	R
Maximum Queue (ft)	29	87	19
Average Queue (ft)	8	31	11
95th Queue (ft)	28	74	24
Link Distance (ft)		310	310
Upstream Blk Time (%)			
Queuing Penalty (veh)			
Storage Bay Dist (ft)	200		
Storage Blk Time (%)			
Queuing Penalty (veh)			

**Intersection: 2: Akers Dr & N Carefree Cir, Interval #1**

Movement	WB	NB	NB
Directions Served	L	L	R
Maximum Queue (ft)	53	43	19
Average Queue (ft)	26	22	18
95th Queue (ft)	58	39	21
Link Distance (ft)		310	310
Upstream Blk Time (%)			
Queuing Penalty (veh)			
Storage Bay Dist (ft)	200		
Storage Blk Time (%)			
Queuing Penalty (veh)			

**Intersection: 2: Akers Dr & N Carefree Cir, Interval #2**

Movement	WB	NB	NB
Directions Served	L	L	R
Maximum Queue (ft)	29	61	35
Average Queue (ft)	8	23	15
95th Queue (ft)	29	51	34
Link Distance (ft)		310	310
Upstream Blk Time (%)			
Queuing Penalty (veh)			
Storage Bay Dist (ft)	200		
Storage Blk Time (%)			
Queuing Penalty (veh)			

**Intersection: 2: Akers Dr & N Carefree Cir, Interval #3**

Movement	WB	NB	NB
Directions Served	L	L	R
Maximum Queue (ft)	95	172	68
Average Queue (ft)	52	107	26
95th Queue (ft)	91	177	54
Link Distance (ft)		310	310
Upstream Blk Time (%)			
Queuing Penalty (veh)			
Storage Bay Dist (ft)	200		
Storage Blk Time (%)			
Queuing Penalty (veh)			

**Intersection: 2: Akers Dr & N Carefree Cir, Interval #4**

Movement	WB	NB	NB
Directions Served	L	L	R
Maximum Queue (ft)	29	46	41
Average Queue (ft)	16	21	21
95th Queue (ft)	39	41	34
Link Distance (ft)		310	310
Upstream Blk Time (%)			
Queuing Penalty (veh)			
Storage Bay Dist (ft)	200		
Storage Blk Time (%)			
Queuing Penalty (veh)			

**Intersection: 2: Akers Dr & N Carefree Cir, All Intervals**

Movement	WB	NB	NB
Directions Served	L	L	R
Maximum Queue (ft)	95	172	68
Average Queue (ft)	25	44	20
95th Queue (ft)	66	116	39
Link Distance (ft)		310	310
Upstream Blk Time (%)			
Queuing Penalty (veh)			
Storage Bay Dist (ft)	200		
Storage Blk Time (%)			
Queuing Penalty (veh)			

**Intersection: 2: Akers Dr & N Carefree Cir, Interval #1**

Movement	WB	NB	NB
Directions Served	L	L	R
Maximum Queue (ft)	27	22	19
Average Queue (ft)	4	16	14
95th Queue (ft)	19	29	24
Link Distance (ft)		310	310
Upstream Blk Time (%)			
Queuing Penalty (veh)			
Storage Bay Dist (ft)	200		
Storage Blk Time (%)			
Queuing Penalty (veh)			

**Intersection: 2: Akers Dr & N Carefree Cir, Interval #2**

Movement	WB	NB	NB
Directions Served	L	L	R
Maximum Queue (ft)	47	62	36
Average Queue (ft)	18	28	10
95th Queue (ft)	47	58	31
Link Distance (ft)		310	310
Upstream Blk Time (%)			
Queuing Penalty (veh)			
Storage Bay Dist (ft)	200		
Storage Blk Time (%)			
Queuing Penalty (veh)			

**Intersection: 2: Akers Dr & N Carefree Cir, Interval #3**

Movement	WB	NB	NB
Directions Served	L	L	R
Maximum Queue (ft)	50	175	54
Average Queue (ft)	18	77	31
95th Queue (ft)	53	162	54
Link Distance (ft)		310	310
Upstream Blk Time (%)			
Queuing Penalty (veh)			
Storage Bay Dist (ft)	200		
Storage Blk Time (%)			
Queuing Penalty (veh)			

**Intersection: 2: Akers Dr & N Carefree Cir, Interval #4**

Movement	WB	NB	NB
Directions Served	L	L	R
Maximum Queue (ft)	31	66	36
Average Queue (ft)	13	41	14
95th Queue (ft)	37	64	33
Link Distance (ft)		310	310
Upstream Blk Time (%)			
Queuing Penalty (veh)			
Storage Bay Dist (ft)	200		
Storage Blk Time (%)			
Queuing Penalty (veh)			

**Intersection: 2: Akers Dr & N Carefree Cir, All Intervals**

Movement	WB	NB	NB
Directions Served	L	L	R
Maximum Queue (ft)	50	175	54
Average Queue (ft)	13	40	17
95th Queue (ft)	42	101	41
Link Distance (ft)		310	310
Upstream Blk Time (%)			
Queuing Penalty (veh)			
Storage Bay Dist (ft)	200		
Storage Blk Time (%)			
Queuing Penalty (veh)			

**Intersection: 2: Akers Dr & N Carefree Cir, Interval #1**

Movement	WB	NB	NB
Directions Served	L	L	R
Maximum Queue (ft)	76	321	64
Average Queue (ft)	35	266	19
95th Queue (ft)	71	395	52
Link Distance (ft)		310	310
Upstream Blk Time (%)		53	
Queuing Penalty (veh)		51	
Storage Bay Dist (ft)	200		
Storage Blk Time (%)			
Queuing Penalty (veh)			

**Intersection: 2: Akers Dr & N Carefree Cir, Interval #2**

Movement	WB	NB	NB
Directions Served	L	L	R
Maximum Queue (ft)	75	323	66
Average Queue (ft)	31	320	23
95th Queue (ft)	65	327	60
Link Distance (ft)		310	310
Upstream Blk Time (%)		94	
Queuing Penalty (veh)		89	
Storage Bay Dist (ft)	200		
Storage Blk Time (%)			
Queuing Penalty (veh)			

**Intersection: 2: Akers Dr & N Carefree Cir, Interval #3**

Movement	EB	WB	NB
Directions Served	R	L	L
Maximum Queue (ft)	20	178	310
Average Queue (ft)	3	112	310
95th Queue (ft)	14	196	310
Link Distance (ft)			310
Upstream Blk Time (%)			100
Queuing Penalty (veh)			185
Storage Bay Dist (ft)	175	200	
Storage Blk Time (%)			
Queuing Penalty (veh)			

**Intersection: 2: Akers Dr & N Carefree Cir, Interval #4**

Movement	WB	NB	NB
Directions Served	L	L	R
Maximum Queue (ft)	72	321	137
Average Queue (ft)	30	317	61
95th Queue (ft)	70	325	142
Link Distance (ft)		310	310
Upstream Blk Time (%)		92	
Queuing Penalty (veh)		87	
Storage Bay Dist (ft)	200		
Storage Blk Time (%)			
Queuing Penalty (veh)			

**Intersection: 2: Akers Dr & N Carefree Cir, All Intervals**

Movement	EB	WB	NB	NB
Directions Served	R	L	L	R
Maximum Queue (ft)	20	178	323	137
Average Queue (ft)	1	52	303	26
95th Queue (ft)	7	130	378	86
Link Distance (ft)			310	310
Upstream Blk Time (%)			85	
Queuing Penalty (veh)			103	
Storage Bay Dist (ft)	175	200		
Storage Blk Time (%)				
Queuing Penalty (veh)				

**Intersection: 2: Akers Dr & N Carefree Cir, Interval #1**

Movement	EB	WB	NB	NB
Directions Served	R	L	L	R
Maximum Queue (ft)	27	111	310	19
Average Queue (ft)	4	76	278	8
95th Queue (ft)	19	110	371	23
Link Distance (ft)			310	310
Upstream Blk Time (%)			66	
Queuing Penalty (veh)			86	
Storage Bay Dist (ft)	175	200		
Storage Blk Time (%)				
Queuing Penalty (veh)				

**Intersection: 2: Akers Dr & N Carefree Cir, Interval #2**

Movement	EB	WB	NB
Directions Served	R	L	L
Maximum Queue (ft)	23	205	310
Average Queue (ft)	6	114	310
95th Queue (ft)	23	195	310
Link Distance (ft)			310
Upstream Blk Time (%)			100
Queuing Penalty (veh)			130
Storage Bay Dist (ft)	175	200	
Storage Blk Time (%)		0	
Queuing Penalty (veh)		2	

**Intersection: 2: Akers Dr & N Carefree Cir, Interval #3**

Movement	EB	WB	WB	WB	NB	NB
Directions Served	R	L	T	T	L	R
Maximum Queue (ft)	22	225	356	294	310	56
Average Queue (ft)	3	193	82	42	310	10
95th Queue (ft)	16	249	305	212	310	43
Link Distance (ft)			873	873	310	310
Upstream Blk Time (%)					100	
Queuing Penalty (veh)					261	
Storage Bay Dist (ft)	175	200				
Storage Blk Time (%)		23	1			
Queuing Penalty (veh)		119	1			



**Intersection: 2: Akers Dr & N Carefree Cir, Interval #4**

Movement	EB	WB	NB
Directions Served	R	L	L
Maximum Queue (ft)	20	91	310
Average Queue (ft)	3	51	310
95th Queue (ft)	14	81	310
Link Distance (ft)			310
Upstream Blk Time (%)			100
Queuing Penalty (veh)			130
Storage Bay Dist (ft)	175	200	
Storage Blk Time (%)			
Queuing Penalty (veh)			

**Intersection: 2: Akers Dr & N Carefree Cir, All Intervals**

Movement	EB	WB	WB	WB	NB	NB
Directions Served	R	L	T	T	L	R
Maximum Queue (ft)	27	225	356	294	310	56
Average Queue (ft)	4	108	21	11	302	5
95th Queue (ft)	18	212	146	101	354	24
Link Distance (ft)			873	873	310	310
Upstream Blk Time (%)					91	
Queuing Penalty (veh)					152	
Storage Bay Dist (ft)	175	200				
Storage Blk Time (%)		6	0			
Queuing Penalty (veh)		30	0			

**Intersection: 2: Akers Dr & N Carefree Cir, Interval #1**

Movement	EB	WB	NB	NB
Directions Served	R	L	L	R
Maximum Queue (ft)	22	53	286	64
Average Queue (ft)	3	24	210	28
95th Queue (ft)	15	53	298	55
Link Distance (ft)			310	310
Upstream Blk Time (%)				
Queuing Penalty (veh)				
Storage Bay Dist (ft)	175	200		
Storage Blk Time (%)				
Queuing Penalty (veh)				

**Intersection: 2: Akers Dr & N Carefree Cir, Interval #2**

Movement	EB	WB	NB	NB
Directions Served	R	L	L	R
Maximum Queue (ft)	22	53	310	61
Average Queue (ft)	3	31	309	23
95th Queue (ft)	16	58	313	58
Link Distance (ft)			310	310
Upstream Blk Time (%)			87	
Queuing Penalty (veh)			90	
Storage Bay Dist (ft)	175	200		
Storage Blk Time (%)				
Queuing Penalty (veh)				

**Intersection: 2: Akers Dr & N Carefree Cir, Interval #3**

Movement	EB	WB	NB	NB
Directions Served	R	L	L	R
Maximum Queue (ft)	20	93	324	322
Average Queue (ft)	3	60	312	134
95th Queue (ft)	14	85	320	390
Link Distance (ft)			310	310
Upstream Blk Time (%)			99	45
Queuing Penalty (veh)			198	89
Storage Bay Dist (ft)	175	200		
Storage Blk Time (%)				
Queuing Penalty (veh)				

**Intersection: 2: Akers Dr & N Carefree Cir, Interval #4**

Movement	WB	NB	NB
Directions Served	L	L	R
Maximum Queue (ft)	74	310	310
Average Queue (ft)	30	310	310
95th Queue (ft)	64	310	310
Link Distance (ft)		310	310
Upstream Blk Time (%)		100	100
Queuing Penalty (veh)		103	103
Storage Bay Dist (ft)	200		
Storage Blk Time (%)			
Queuing Penalty (veh)			

**Intersection: 2: Akers Dr & N Carefree Cir, All Intervals**

Movement	EB	WB	NB	NB
Directions Served	R	L	L	R
Maximum Queue (ft)	22	93	324	322
Average Queue (ft)	2	37	285	124
95th Queue (ft)	13	73	370	356
Link Distance (ft)			310	310
Upstream Blk Time (%)			72	36
Queuing Penalty (veh)			98	48
Storage Bay Dist (ft)	175	200		
Storage Blk Time (%)				
Queuing Penalty (veh)				

**Intersection: 2: Akers Dr & N Carefree Cir, Interval #1**

Movement	WB	NB	NB
Directions Served	L	L	R
Maximum Queue (ft)	159	324	42
Average Queue (ft)	104	292	12
95th Queue (ft)	178	371	38
Link Distance (ft)		310	310
Upstream Blk Time (%)		67	
Queuing Penalty (veh)		89	
Storage Bay Dist (ft)	200		
Storage Blk Time (%)			
Queuing Penalty (veh)			

**Intersection: 2: Akers Dr & N Carefree Cir, Interval #2**

Movement	EB	WB	NB	NB
Directions Served	R	L	L	R
Maximum Queue (ft)	49	94	322	19
Average Queue (ft)	7	50	314	8
95th Queue (ft)	35	102	322	22
Link Distance (ft)			310	310
Upstream Blk Time (%)			99	
Queuing Penalty (veh)			131	
Storage Bay Dist (ft)	175	200		
Storage Blk Time (%)				
Queuing Penalty (veh)				

**Intersection: 2: Akers Dr & N Carefree Cir, Interval #3**

Movement	WB	WB	WB	WB	NB	NB
Directions Served	L	T	T	T	L	R
Maximum Queue (ft)	225	666	628	495	310	20
Average Queue (ft)	213	390	346	71	310	5
95th Queue (ft)	241	810	724	356	310	20
Link Distance (ft)		873	873	873	310	310
Upstream Blk Time (%)					100	
Queuing Penalty (veh)					266	
Storage Bay Dist (ft)	200					
Storage Blk Time (%)	61	0				
Queuing Penalty (veh)	318	0				

**Intersection: 2: Akers Dr & N Carefree Cir, Interval #4**

Movement	EB	WB	WB	WB	WB	NB
Directions Served	R	L	T	T	T	L
Maximum Queue (ft)	23	225	595	622	372	310
Average Queue (ft)	6	191	371	365	53	310
95th Queue (ft)	23	284	774	767	268	310
Link Distance (ft)			873	873	873	310
Upstream Blk Time (%)						100
Queuing Penalty (veh)						133
Storage Bay Dist (ft)	175	200				
Storage Blk Time (%)		64	4			
Queuing Penalty (veh)		246	4			

**Intersection: 2: Akers Dr & N Carefree Cir, All Intervals**

Movement	EB	WB	WB	WB	WB	NB	NB
Directions Served	R	L	T	T	T	L	R
Maximum Queue (ft)	49	225	666	628	495	324	42
Average Queue (ft)	3	140	190	178	31	307	6
95th Queue (ft)	21	267	618	580	217	349	24
Link Distance (ft)			873	873	873	310	310
Upstream Blk Time (%)							91
Queuing Penalty (veh)							155
Storage Bay Dist (ft)	175	200					
Storage Blk Time (%)		31	1				
Queuing Penalty (veh)		141	1				

**Intersection: 2: Akers Dr & N Carefree Cir, Interval #1**

Movement	EB	EB	EB	EB	WB	WB	WB	WB	NB	NB
Directions Served	T	T	T	R	L	T	T	T	L	R
Maximum Queue (ft)	93	97	74	31	71	158	74	31	109	71
Average Queue (ft)	63	52	22	16	42	82	61	21	37	31
95th Queue (ft)	89	91	63	38	69	140	78	43	93	64
Link Distance (ft)	1145	1145	1145			873	873	873	310	310
Upstream Blk Time (%)										
Queuing Penalty (veh)										
Storage Bay Dist (ft)	175				200					
Storage Blk Time (%)										
Queuing Penalty (veh)										

**Intersection: 2: Akers Dr & N Carefree Cir, Interval #2**

Movement	EB	EB	EB	EB	WB	WB	WB	WB	NB	NB
Directions Served	T	T	T	R	L	T	T	T	L	R
Maximum Queue (ft)	134	73	30	31	71	177	113	95	66	40
Average Queue (ft)	72	33	4	23	37	105	73	44	42	23
95th Queue (ft)	132	76	22	39	51	164	119	99	76	41
Link Distance (ft)	1145	1145	1145			873	873	873	310	310
Upstream Blk Time (%)										
Queuing Penalty (veh)										
Storage Bay Dist (ft)	175				200					
Storage Blk Time (%)										
Queuing Penalty (veh)										

**Intersection: 2: Akers Dr & N Carefree Cir, Interval #3**

Movement	EB	EB	EB	EB	WB	WB	WB	WB	NB	NB
Directions Served	T	T	T	R	L	T	T	T	L	R
Maximum Queue (ft)	116	75	53	31	130	117	97	72	107	62
Average Queue (ft)	76	36	15	24	76	92	59	25	49	37
95th Queue (ft)	120	78	48	41	125	127	92	62	99	65
Link Distance (ft)	1145	1145	1145			873	873	873	310	310
Upstream Blk Time (%)										
Queuing Penalty (veh)										
Storage Bay Dist (ft)	175				200					
Storage Blk Time (%)										
Queuing Penalty (veh)										

**Intersection: 2: Akers Dr & N Carefree Cir, Interval #4**

Movement	EB	EB	EB	EB	WB	WB	WB	WB	NB	NB
Directions Served	T	T	T	R	L	T	T	T	L	R
Maximum Queue (ft)	96	75	31	29	96	116	90	53	88	42
Average Queue (ft)	61	55	8	15	53	83	47	28	67	28
95th Queue (ft)	87	86	30	38	86	131	93	61	96	47
Link Distance (ft)	1145	1145	1145			873	873	873	310	310
Upstream Blk Time (%)										
Queuing Penalty (veh)										
Storage Bay Dist (ft)	175				200					
Storage Blk Time (%)										
Queuing Penalty (veh)										

**Intersection: 2: Akers Dr & N Carefree Cir, All Intervals**

Movement	EB	EB	EB	EB	WB	WB	WB	WB	NB	NB
Directions Served	T	T	T	R	L	T	T	T	L	R
Maximum Queue (ft)	134	97	74	31	130	177	113	95	109	71
Average Queue (ft)	68	44	12	20	52	90	60	29	49	30
95th Queue (ft)	111	86	44	40	93	144	101	71	96	56
Link Distance (ft)	1145	1145	1145			873	873	873	310	310
Upstream Blk Time (%)										
Queuing Penalty (veh)										
Storage Bay Dist (ft)	175				200					
Storage Blk Time (%)										
Queuing Penalty (veh)										

**Intersection: 2: Akers Dr & N Carefree Cir, Interval #1**

Movement	EB	EB	EB	EB	WB	WB	WB	WB	NB	NB
Directions Served	T	T	T	R	L	T	T	T	L	R
Maximum Queue (ft)	215	195	113	63	73	167	139	53	86	47
Average Queue (ft)	138	114	53	40	40	87	53	21	70	38
95th Queue (ft)	206	183	113	63	69	147	113	52	98	54
Link Distance (ft)	1145	1145	1145			873	873	873	310	310
Upstream Blk Time (%)										
Queuing Penalty (veh)										
Storage Bay Dist (ft)	175				200					
Storage Blk Time (%)										
Queuing Penalty (veh)										

**Intersection: 2: Akers Dr & N Carefree Cir, Interval #2**

Movement	EB	EB	EB	EB	WB	WB	WB	WB	NB	NB
Directions Served	T	T	T	R	L	T	T	T	L	R
Maximum Queue (ft)	200	136	116	53	70	142	97	92	109	88
Average Queue (ft)	117	85	47	31	52	98	68	51	67	37
95th Queue (ft)	169	128	102	59	69	144	105	88	114	76
Link Distance (ft)	1145	1145	1145			873	873	873	310	310
Upstream Blk Time (%)										
Queuing Penalty (veh)										
Storage Bay Dist (ft)	175				200					
Storage Blk Time (%)										
Queuing Penalty (veh)										

**Intersection: 2: Akers Dr & N Carefree Cir, Interval #3**

Movement	EB	EB	EB	EB	WB	WB	WB	WB	NB	NB
Directions Served	T	T	T	R	L	T	T	T	L	R
Maximum Queue (ft)	203	175	71	53	97	138	97	73	106	82
Average Queue (ft)	156	128	45	29	46	80	68	33	68	48
95th Queue (ft)	210	194	69	53	72	124	99	84	102	81
Link Distance (ft)	1145	1145	1145			873	873	873	310	310
Upstream Blk Time (%)										
Queuing Penalty (veh)										
Storage Bay Dist (ft)	175				200					
Storage Blk Time (%)										
Queuing Penalty (veh)										



**Intersection: 2: Akers Dr & N Carefree Cir, Interval #4**

Movement	EB	EB	EB	EB	WB	WB	WB	WB	NB	NB
Directions Served	T	T	T	R	L	T	T	T	L	R
Maximum Queue (ft)	179	139	91	72	74	180	94	31	68	64
Average Queue (ft)	124	80	53	31	47	90	55	25	45	41
95th Queue (ft)	169	125	100	64	85	130	91	42	71	61
Link Distance (ft)	1145	1145	1145			873	873	873	310	310
Upstream Blk Time (%)										
Queuing Penalty (veh)										
Storage Bay Dist (ft)				175	200					
Storage Blk Time (%)						0				
Queuing Penalty (veh)						0				

**Intersection: 2: Akers Dr & N Carefree Cir, All Intervals**

Movement	EB	EB	EB	EB	WB	WB	WB	WB	NB	NB
Directions Served	T	T	T	R	L	T	T	T	L	R
Maximum Queue (ft)	215	195	116	72	97	180	139	92	109	88
Average Queue (ft)	134	102	50	33	46	89	61	32	62	41
95th Queue (ft)	195	168	98	61	76	138	105	73	101	70
Link Distance (ft)	1145	1145	1145			873	873	873	310	310
Upstream Blk Time (%)										
Queuing Penalty (veh)										
Storage Bay Dist (ft)				175	200					
Storage Blk Time (%)						0				
Queuing Penalty (veh)						0				