

**ENGINEERING STUDY  
for  
THE GARDENS AT NORTH CAREFREE  
WASTEWATER SYSTEM IMPROVEMENTS**

**August 14, 2019**

Prepared For:

**Mule Deer Investments, LLC  
2727 Glen Arbor Drive  
Colorado Springs, CO 80920**

Prepared By:

**Stantec**

5725 Mark Dabling Boulevard, Suite 190  
Colorado Springs, CO 80919  
719.432.6889

**Project No. 187608744**

\*\*\*\*\* CONTENTS \*\*\*\*\*

1.0 EXECUTIVE SUMMARY.....	1
2.0 INTRODUCTION.....	2
2.1 Purpose.....	2
2.2 Scope.....	2
3.0 EXISTING CONDITIONS.....	3
3.1 Description of the Service Area.....	3
3.2 Land Use.....	3
3.3 Topography and Floodplains.....	3
3.4 Geology.....	3
3.5 Groundwater.....	3
3.6 Climate.....	4
3.7 Natural Hazards Analysis.....	4
3.8 Organizational Context.....	4
3.9 Wastewater Facilities.....	4
3.10 Relationship to Neighboring Water and Wastewater Facilities.....	4
3.11 Wastewater Demand.....	4
4.0 DEVELOPED CONDITIONS.....	8
4.1 Land Use.....	8
4.2 Population and Employment.....	8
4.3 Wastewater Demand.....	8
4.4 Wastewater Treatment.....	8
5.0 WASTEWATER SYSTEM IMPROVEMENTS.....	9
5.1 General.....	9
5.2 Wastewater Collection and Treatment.....	9
5.3 Rates and Charges.....	9

**\*\*\*\*\* APPENDICES \*\*\*\*\***

Appendix A	Cherokee Metropolitan District Report
Appendix B	Cherokee Metropolitan District letter of commitment

**\*\*\*\*\* LIST OF FIGURES \*\*\*\*\***

Figure 1	Vicinity Map
Figure 2	1-Mile Radius Map
Figure 3	Utility Plan

## **1.0 EXECUTIVE SUMMARY**

This report presents the results of the engineering study for wastewater system improvements serving The Gardens at North Carefree, a proposed development located south of North Carefree and east of Akers Drive in El Paso County, Colorado.

The Gardens at North Carefree consists of 70 single family lots on 11.56 acres.

The service area is located within the Sand Creek Basin. The proposed development is within the Cherokee Metropolitan District service area.

The average wastewater to be produced by The Gardens at North Carefree is estimated to be 15,497 gallons per day; the Cherokee Metropolitan District will treat this wastewater.

The Cherokee Metropolitan District operates under a permit issued by the Colorado Water Quality Control Division, providing for discharge to the Black Squirrel Creek.

## **2.0 INTRODUCTION**

### **2.1 Purpose**

The purpose of this report is to present wastewater system improvements recommended to serve The Gardens at North Carefree, a land development project located in El Paso County. It is also intended to serve as a guideline for the ensuing design of recommended improvements.

### **2.2 Scope**

The scope of this report includes:

1. The definition of the service area as well as identification of significant physical and environmental characteristics and constraints;
2. An analysis of available data to determine existing and to project future wastewater demands; and,
3. A description of legal, institutional and managerial arrangements that ensure adequate control of the proposed improvements.

### **3.0 EXISTING CONDITIONS**

#### **3.1 Description of the Service Area**

The Gardens at North Carefree development consists of approximately 11.64 acres with a mixture of residential and open space uses and is located due south of North Carefree Circle and due east of Akers Drive within the East Half of Section 29, Township 13 South, Range 65 West.

Property west south and north of the site is currently being served by the Cherokee Metropolitan District for both water and sewer.

#### **3.2 Land Use**

The Gardens at North Carefree development is located in El Paso County on the eastern edge of the City of Colorado Springs urban development. Vacant land can be found east of the site. Most of the vacant land has been through City or County planning processes for development.

#### **3.3 Topography and Floodplains**

The topography of the service area is typical of a high desert, short grass prairie with primarily relatively flat slopes generally ranging from 2% to 4%. However, slopes in the 6% to 10% range can be found along the eastern boundary. The service area drains generally west to Akers Drive where existing water and sewer stubs are located.

The Flood Insurance Rate Map (FIRM No. 08041C0539-F dated 3/17/99) indicates that there is no floodplain in the vicinity of the proposed site as shown on Figure 2.

#### **3.4 Geology**

The site is composed of a single soil type. From the NRCS report in Appendix A, the site falls into the following soil type:

97 – Truckton sandy loam (3-9%) – Type A Soil

Hydrologic soil groups are based on estimates of runoff potential. Soils are assigned to one of four groups according to the rate of water infiltration when the soils are not protected by vegetation, are thoroughly wet, and receive precipitation from long-duration storms. Group A soil is defined by:

Group A. Soils having a high infiltration rate (low runoff potential) when thoroughly wet. These consist mainly of deep, well drained to excessively drained sands or gravelly sands. These soils have a high rate of water transmission.

#### **3.5 Groundwater**

No shallow ground water has been identified on site.

### **3.6 Climate**

The climate of the study area is characterized by mild summers and winters, light precipitation, high evaporation and moderately high wind velocities.

The climate of the site is typical of a sub-humid to semiarid climate with mild summers and winters. The average temperature is 31 degrees F in the winter and 68.4 degrees in the summer. Total annual precipitation is 15.21 inches.

### **3.7 Natural Hazards Analysis**

Natural hazards analysis indicates that no unusual surface or subsurface hazards are located in the service area. However, because the soils are cohesionless, sloughing of steep banks during drilling and/or excavation could occur. By siting improvements in a manner that provides an opportunity to lay the banks of excavations back at a 1:1 slope during construction, the problems associated with sloughing soils can be minimized.

### **3.8 Organizational Context**

The Gardens at North Carefree is located in El Paso County and lies within the service area of the Cherokee Metropolitan District.

### **3.9 Wastewater Facilities**

Primary Wastewater Facilities are located outside of the boundaries of the Gardens at North Carefree development. Cherokee Metropolitan District facilities include:

- Wastewater Treatment Facility
- Wastewater Collection and pumping facilities

### **3.10 Relationship to Neighboring Water and Wastewater Facilities**

The location of other major water and wastewater facilities, relative to the Gardens at North Carefree Development, are shown on Figure 2.

Figure 2 identifies water wells and habitable buildings within a 1-mile radius of the center of The Gardens at North Carefree. No known wells are within the 1-mile radius.

### **3.11 Wastewater Demand**

The Gardens at North Carefree will be serviced by the Cherokee Metropolitan District and is assumed to have the same unit wastewater demands as the rest of the Cherokee Metropolitan District. Residential Demand within the District is estimated to be 80% of the water demand of 0.31 ac-ft./year per SFE or 22.01 ac-ft. or 19,371 GPD; Waste flow is estimated to be 15,497 GPD.

GARDENS AT NORTH CAREFREE BOUNDARY

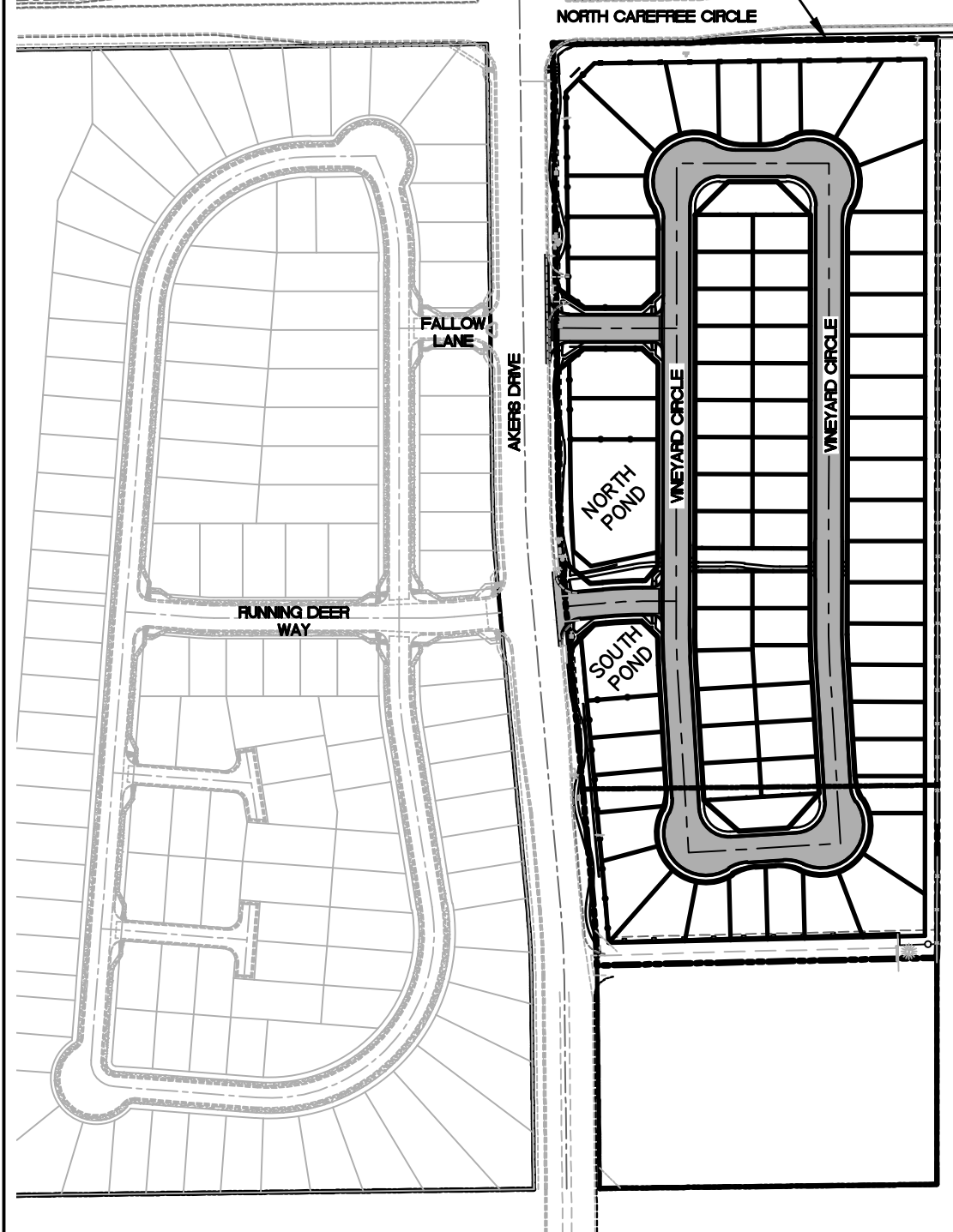

V:\52876\ACTIVE\187608744\MULE DEER\REPORTS\DRAINAGE\EXHIBITS\FDR\FIG01-VMAP.DWG  
8/1/2019 2:44 PM

JANUARY, 2019  
187608744

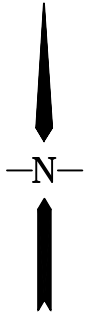

5725 MARK DABLING BLVD, SUITE 190  
COLORADO SPRINGS, CO 80919  
www.stantec.com

Client/Project  
MULE DEER INVESTMENTS, LLC  
GARDENS AT NORTH CAREFREE

Figure No.  
1.0  
Title  
VICINITY MAP



V:\52876\ACTIVE\187608744-MULE DEER\REPORTS\WATER SUPPLY REPORT\ONE-MILE RADIUS MAP.DWG  
8/3/2018 10:58 AM



 **Stantec**  
5725 MARK DABLING BLVD, SUITE 190  
COLORADO SPRINGS, CO 80919  
www.stantec.com

Client/Project  
MULE DEER INVESTMENTS, LLC  
GARDENS AT NORTH CAREFREE

Figure No. \_\_\_\_\_  
1.0

Title  
ONE MILE RADIUS MAP

JUNE, 2017  
181710214

V:\52876\active\187608744-Mule Deer\CAD\Sheets\Construction Drawings\30 - Master Utility Plan.dwg  
 2019/08/12 9:40 AM By: Durham, Charlene

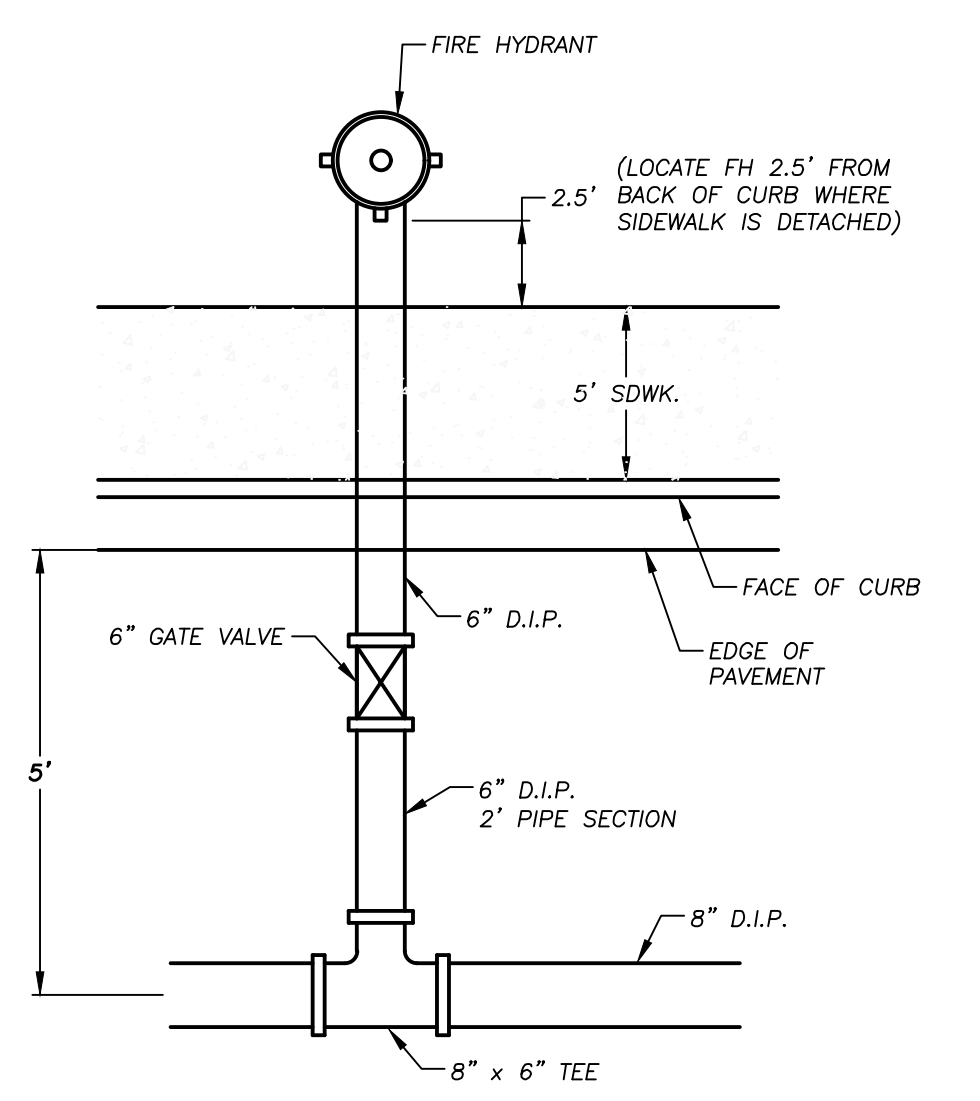
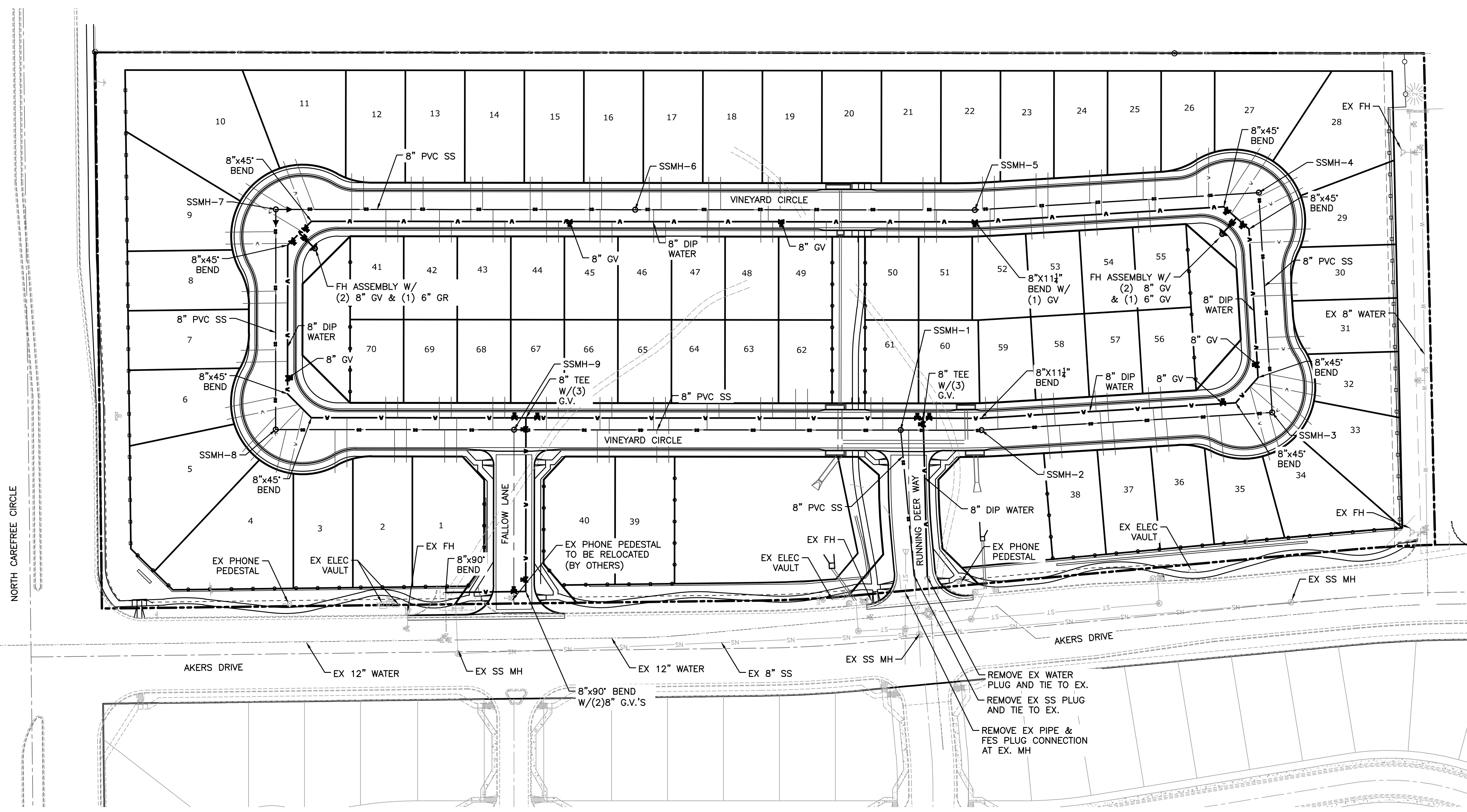

**FIRE HYDRANT CONFIGURATION**  
 SCALE : N.T.S.

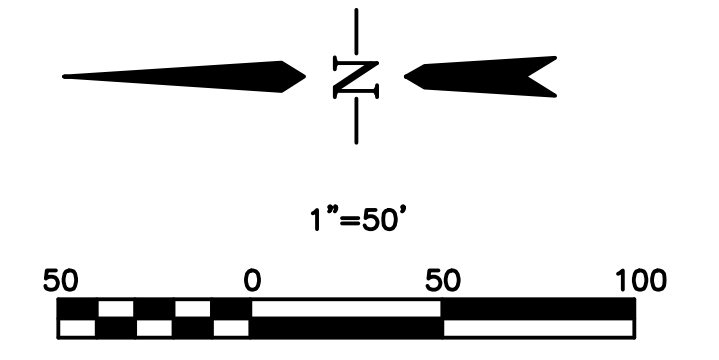

**LEGEND**

- EX WATER
- EX SAN SEWER
- EX GAS
- EX STORM SEWER
- EX WATER VALVE
- EX FIRE HYDRANT
- EX SANITARY SEWER MH
- PR WATER LINE
- PR SANITARY SEWER
- PR STORM SEWER
- PR SANITARY SEWER MANHOLE
- PR STORM SEWER MANHOLE
- PR WATER VALVE
- PR FIRE HYDRANT

- NOTES:**
- MECHANICAL MEANS SHOULD NOT BE USED TO ACCOMPLISH CURVED PIPE ALIGNMENTS WITH THE WASTEWATER PVC PIPE. IT IS THE INTENT THAT THIS SHOULD BE ACCOMPLISHED MANUALLY IN THE TRENCH BY THE INSTALLATION PERSONNEL. THE CURVE SHOULD BE ACCOMPLISHED BY BENDING THE PIPE RATHER THAN DEFLECTING THE JOINTS. OVER-BENDING OF JOINTS SHOULD BE AVOIDED. WATERLINE DUCTILE IRON PIPE DEFLECTIONS TO BE ACCOMPLISHED IN ACCORDANCE WITH SECURITY WATER DISTRICT STANDARDS.
  - THE MINIMUM RADIUS OF CURVATURE FOR 8-INCH PVC DIAMETER PIPE IS 200 FEET.
  - ALL WATER SERVICES TO BE 1" BLUE HDPE PIPE, ASTM D2737; AWWA C901, DR 9, 250 PSI PRESSURE RATING ACCOMPANIED BY A TRACER WIRE (SEE SHEET 2 CHEROKEE METRO UTILITY GENERAL NOTE # 13).

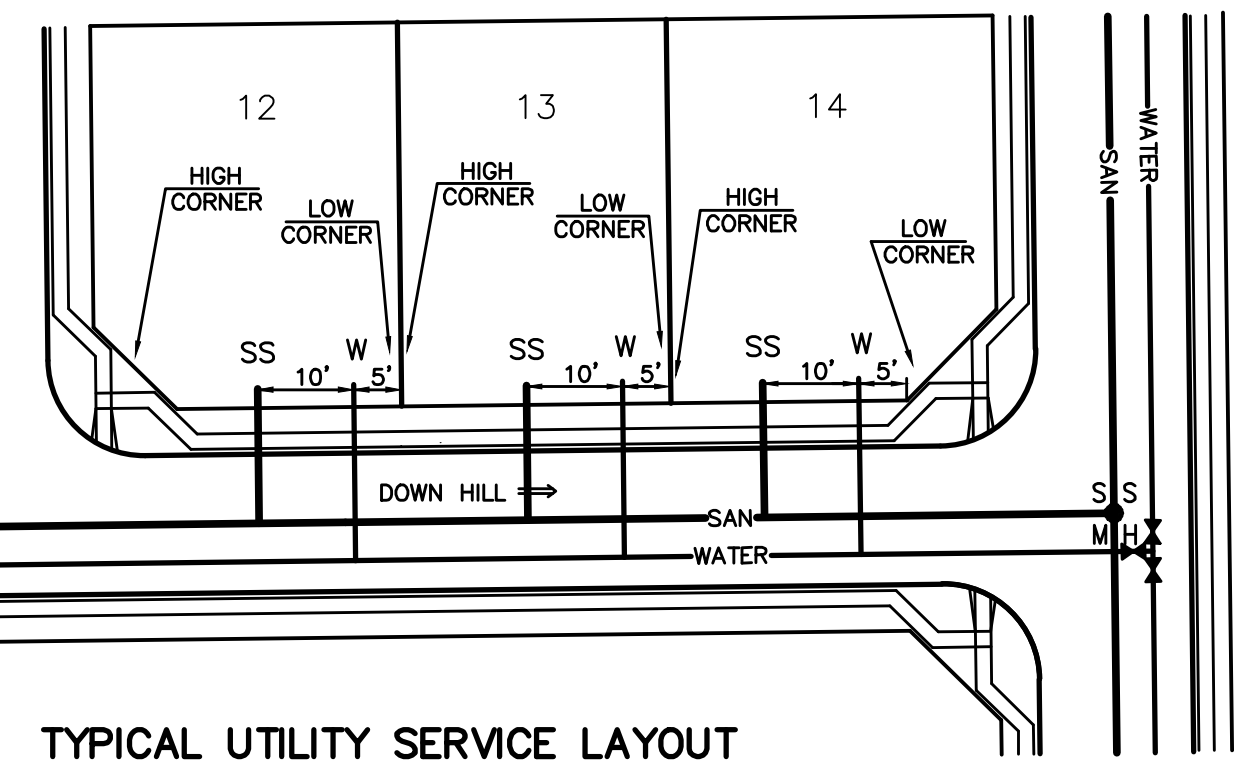

**TYPICAL UTILITY SERVICE LAYOUT**  
 DEVELOPER TO COORDINATE LOCATION OF ELECTRIC, PHONE AND CABLE.

Computer File Information	
Creation Date: 4-25-17	Initials: CMD
Last Modification Date:	Initials:
Full Path & Drawing File Name:	
Acad Ver. 2014	Scale: Units: Feet

Index of Revisions	

**Stantec**  
 Stantec Consulting Inc.  
 5725 MARK DABLING BLVD  
 Suite 190  
 Colorado Springs, CO 80919  
 Tel. (719) 594-4535  
 Fax.  
 www.stantec.com

THE GARDENS AT NORTH CAREFREE MASTER UTILITY PLAN		
Designer: CD	Structure Numbers	
Detailer: MB		
Sheet Subst:		

Project No./Code
187608744
SHEET 33 OF 34

## **4.0 DEVELOPED CONDITIONS**

### **4.1 Land Use**

This report addresses The Gardens at North Carefree development anticipated to be submitted to El Paso County for review in August of 2018. The proposed use is for 71 single family lots.

### **4.2 Population and Employment**

By using the land use information noted above and applying standard unit densities of 2.9 persons per dwelling for single family residential uses, 2.5 persons per dwelling for multifamily residential uses and 600 square feet per employee for commercial/industrial uses, permanent resident, and employment forecasts for The Gardens at North Carefree are 206 permanent residence.

### **4.3 Wastewater Demand**

Residential Demand within the District is estimated to be 80% of the water demand of 0.31 ac-ft./year per SFE or 22.01 ac-ft. or 19,648 GPD; Waste flow is estimated to be 15,718 GPD.

### **4.4 Wastewater Treatment**

The Cherokee Metropolitan District has treatment facilities to meet Colorado Department of Health and Environment standards.

This treatment process is outlined in the report in Appendix A.

## **5.0 WASTEWATER SYSTEM IMPROVEMENTS**

### **5.1 General**

The wastewater system operated by Cherokee Metropolitan District meets the applicable requirements of the Colorado Department of Health and Environment (CDHE).

The wastewater treatment facility is located in the Black Squirrel Creek Basin and processes wastewater to CDHE and U.S. EPA standards prior to discharging.

### **5.2 Wastewater Collection and Treatment**

The wastewater is collected and conveyed to the Wastewater Treatment Facility via a series of underground pipe systems. All pipe and appurtenances will be designed to meet or exceed AWWA standards.

The Wastewater Treatment Facility operates under a permit issued by the Colorado Water Quality Control division, providing for discharge to Black Squirrel Creek. Water quality testing indicates that the treated wastewater exceeds CDHE and U.S. EPA standards prior to discharge back. Specifics concerning treatment are provided in the District report in Appendix A.

### **5.3 Rates and Charges**

The Cherokee Metropolitan District will impose one-time charges to recoup the cost of constructing water system improvements as well as regular periodic billings to recoup continuing costs for operations, maintenance and equipment replacement. This system of rates and charts is outlined in the "Service Plan for the Cherokee Metropolitan District".

**Appendix A**

**Cherokee Metropolitan District Report**

# CHEROKEE MD 2018 Drinking Water Quality Report

## For Calendar Year 2017

*Public Water System ID: CO0121125*

**Esta es información importante. Si no la pueden leer, necesitan que alguien se la traduzca.**

We are pleased to present to you this year's water quality report. Our constant goal is to provide you with a safe and dependable supply of drinking water. Please contact JONATHON SMITH at 719-597-5080 with any questions or for public participation opportunities that may affect water quality.

### General Information

All drinking water, including bottled water, may reasonably be expected to contain at least small amounts of some contaminants. The presence of contaminants does not necessarily indicate that the water poses a health risk. More information about contaminants and potential health effects can be obtained by calling the Environmental Protection Agency's Safe Drinking Water Hotline (1-800-426-4791) or by visiting <http://water.epa.gov/drink/contaminants>.

Some people may be more vulnerable to contaminants in drinking water than the general population. Immunocompromised persons such as persons with cancer undergoing chemotherapy, persons who have undergone organ transplants, people with HIV-AIDS or other immune system disorders, some elderly, and infants can be particularly at risk of infections. These people should seek advice about drinking water from their health care providers. For more information about contaminants and potential health effects, or to receive a copy of the U.S. Environmental Protection Agency (EPA) and the U.S. Centers for Disease Control (CDC) guidelines on appropriate means to lessen the risk of infection by Cryptosporidium and microbiological contaminants call the EPA Safe Drinking Water Hotline at (1-800-426-4791).

The sources of drinking water (both tap water and bottled water) include rivers, lakes, streams, ponds, reservoirs, springs, and wells. As water travels over the surface of the land or through the ground, it dissolves naturally occurring minerals and, in some cases, radioactive material, and can pick up substances resulting from the presence of animals or from human activity. Contaminants that may be present in source water include:

- **Microbial contaminants:** viruses and bacteria that may come from sewage treatment plants, septic systems, agricultural livestock operations, and wildlife.
- **Inorganic contaminants:** salts and metals, which can be naturally-occurring or result from urban storm water runoff, industrial or domestic wastewater discharges, oil and gas production, mining, or farming.
- **Pesticides and herbicides:** may come from a variety of sources, such as agriculture, urban storm water runoff, and residential uses.
- **Radioactive contaminants:** can be naturally occurring or be the result of oil and gas production and mining activities.
- **Organic chemical contaminants:** including synthetic and volatile organic chemicals, which are byproducts of industrial processes and petroleum production, and also may come from gas stations, urban storm water runoff, and septic systems.

In order to ensure that tap water is safe to drink, the Colorado Department of Public Health and Environment prescribes regulations limiting the amount of certain contaminants in water provided by public water systems. The Food and Drug Administration regulations establish limits for contaminants in bottled water that must provide the same protection for public health.

**Lead in Drinking Water**

If present, elevated levels of lead can cause serious health problems (especially for pregnant women and young children). It is possible that lead levels at your home may be higher than other homes in the community as a result of materials used in your home’s plumbing. If you are concerned about lead in your water, you may wish to have your water tested. When your water has been sitting for several hours, you can minimize the potential for lead exposure by flushing your tap for 30 seconds to 2 minutes before using water for drinking or cooking. Additional information on lead in drinking water, testing methods, and steps you can take to minimize exposure is available from the Safe Drinking Water Hotline (1-800-426-4791) or at <http://www.epa.gov/safewater/lead>.

**Source Water Assessment and Protection (SWAP)**

The Colorado Department of Public Health and Environment has provided us with a Source Water Assessment Report for our water supply. For general information or to obtain a copy of the report please visit [www.colorado.gov/cdphe/ccr](http://www.colorado.gov/cdphe/ccr). The report is located under “Guidance: Source Water Assessment Reports”. Search the table using 121125, CHEROKEE MD, or by contacting JONATHON SMITH at 719-597-5080. The Source Water Assessment Report provides a screening-level evaluation of potential contamination that ***could*** occur. It ***does not*** mean that the contamination ***has or will*** occur. We can use this information to evaluate the need to improve our current water treatment capabilities and prepare for future contamination threats. This can help us ensure that quality finished water is delivered to your homes. In addition, the source water assessment results provide a starting point for developing a source water protection plan. Potential sources of contamination in our source water area are listed on the next page.

Please contact us to learn more about what you can do to help protect your drinking water sources, any questions about the Drinking Water Quality Report, to learn more about our system, or to attend scheduled public meetings. We want you, our valued customers, to be informed about the services we provide and the quality water we deliver to you every day.

**Our Water Sources**

<u>Source</u>	<u>Source Type</u>	<u>Water Type</u>	<u>Potential Source(s) of Contamination</u>
WELLS 1 THROUGH 13	Well	Groundwater	Row crops, fallow, small grains, pasture/hay, septic systems, road miles
WELLS 15 THROUGH 20	Well	Groundwater	
WELL 21 AR-1	Well	Groundwater	
WELL 22 DN-4	Well	Groundwater	

## Terms and Abbreviations

- **Maximum Contaminant Level (MCL)** – The highest level of a contaminant allowed in drinking water.
- **Treatment Technique (TT)** – A required process intended to reduce the level of a contaminant in drinking water.
- **Health-Based** – A violation of either a MCL or TT.
- **Non-Health-Based** – A violation that is not a MCL or TT.
- **Action Level (AL)** – The concentration of a contaminant which, if exceeded, triggers treatment and other regulatory requirements.
- **Maximum Residual Disinfectant Level (MRDL)** – The highest level of a disinfectant allowed in drinking water. There is convincing evidence that addition of a disinfectant is necessary for control of microbial contaminants.
- **Maximum Contaminant Level Goal (MCLG)** – The level of a contaminant in drinking water below which there is no known or expected risk to health. MCLGs allow for a margin of safety.
- **Maximum Residual Disinfectant Level Goal (MRDLG)** – The level of a drinking water disinfectant, below which there is no known or expected risk to health. MRDLGs do not reflect the benefits of the use of disinfectants to control microbial contaminants.
- **Violation (No Abbreviation)** – Failure to meet a Colorado Primary Drinking Water Regulation.
- **Formal Enforcement Action (No Abbreviation)** – Escalated action taken by the State (due to the risk to public health, or number or severity of violations) to bring a non-compliant water system back into compliance.
- **Variance and Exemptions (V/E)** – Department permission not to meet a MCL or treatment technique under certain conditions.
- **Gross Alpha (No Abbreviation)** – Gross alpha particle activity compliance value. It includes radium-226, but excludes radon 222, and uranium.
- **Picocuries per liter (pCi/L)** – Measure of the radioactivity in water.
- **Nephelometric Turbidity Unit (NTU)** – Measure of the clarity or cloudiness of water. Turbidity in excess of 5 NTU is just noticeable to the typical person.
- **Compliance Value (No Abbreviation)** – Single or calculated value used to determine if regulatory contaminant level (e.g. MCL) is met. Examples of calculated values are the 90<sup>th</sup> Percentile, Running Annual Average (RAA) and Locational Running Annual Average (LRAA).
- **Average (x-bar)** – Typical value.
- **Range (R)** – Lowest value to the highest value.
- **Sample Size (n)** – Number or count of values (i.e. number of water samples collected).
- **Parts per million = Milligrams per liter (ppm = mg/L)** – One part per million corresponds to one minute in two years or a single penny in \$10,000.
- **Parts per billion = Micrograms per liter (ppb = ug/L)** – One part per billion corresponds to one minute in 2,000 years, or a single penny in \$10,000,000.
- **Not Applicable (N/A)** – Does not apply or not available.
- **Level 1 Assessment** – A study of the water system to identify potential problems and determine (if possible) why total coliform bacteria have been found in our water system.
- **Level 2 Assessment** – A very detailed study of the water system to identify potential problems and determine (if possible) why an E. coli MCL violation has occurred and/or why total coliform bacteria have been found in our water system on multiple occasions.



### Detected Contaminants

CHEROKEE MD routinely monitors for contaminants in your drinking water according to Federal and State laws. The following table(s) show all detections found in the period of January 1 to December 31, 2017 unless otherwise noted. The State of Colorado requires us to monitor for certain contaminants less than once per year because the concentrations of these contaminants are not expected to vary significantly from year to year, or the system is not considered vulnerable to this type of contamination. Therefore, some of our data, though representative, may be more than one year old. Violations and Formal Enforcement Actions, if any, are reported in the next section of this report.

**Note:** Only detected contaminants sampled within the last 5 years appear in this report. If no tables appear in this section then no contaminants were detected in the last round of monitoring.

<b>Disinfectants Sampled in the Distribution System</b>						
<b>TT Requirement:</b> At least 95% of samples per period (month or quarter) must be at least 0.2 ppm <b>OR</b> If sample size is less than 40 no more than 1 sample is below 0.2 ppm <b>Typical Sources:</b> Water additive used to control microbes						
Disinfectant Name	Time Period	Results	Number of Samples Below Level	Sample Size	TT Violation	MRDL
Chlorine	01/01/2017 to 12/31/2017	Lowest period percentage of samples meeting TT requirement: 96%	0	255	No	4.0 ppm

<b>Lead and Copper Sampled in the Distribution System</b>								
Contaminant Name	Time Period	90 <sup>th</sup> Percentile	Sample Size	Unit of Measure	90 <sup>th</sup> Percentile AL	Sample Sites Above AL	90 <sup>th</sup> Percentile AL Exceedance	Typical Sources
Copper	06/13/2017 to 06/15/2017	0.42	30	ppm	1.3	0	No	Corrosion of household plumbing systems; Erosion of natural deposits
Lead	06/13/2017 to 06/15/2017	4	30	ppb	15	2	No	Corrosion of household plumbing systems; Erosion of natural deposits

**Disinfection Byproducts Sampled in the Distribution System**

Name	Year	Average	Range Low – High	Sample Size	Unit of Measure	MCL	MCLG	Highest Compliance Value	MCL Violation	Typical Sources
Total Haloacetic Acids (HAA5)	2017	4.46	0 to 8.5	16	ppb	60	N/A	8.5	No	Byproduct of drinking water disinfection
Total Trihalomethanes (TTHM)	2017	19.03	5.6 to 34.5	16	ppb	80	N/A	34.5	No	Byproduct of drinking water disinfection

**Radionuclides Sampled at the Entry Point to the Distribution System**

Typical Sources	Year	Average	Range Low – High	Sample Size	Unit of Measure	MCL	MCLG	MCL Violation	Typical Sources
Gross Alpha	2017	1.1	1.1 to 1.1	1	pCi/L	15	0	No	Erosion of natural deposits
Combined Radium	2017	3.4	3.4 to 3.4	1	pCi/L	5	0	No	Erosion of natural deposits
Gross Beta Particle Activity	2016	0.1	0.1 to 0.1	1	pCi/L*	50	0	No	Decay of natural and man-made deposits

\*The MCL for Gross Beta Particle Activity is 4 mrem/year. Since there is no simple conversion between mrem/year and pCi/L EPA considers 50 pCi/L to be the level of concern for Gross Beta Particle Activity.

**Inorganic Contaminants Sampled at the Entry Point to the Distribution System**

Contaminant Name	Year	Average	Range Low – High	Sample Size	Unit of Measure	MCL	MCLG	MCL Violation	Typical Sources
Arsenic	2017	0.33	0 to 2	6	ppb	10	0	No	Erosion of natural deposits; runoff from orchards; runoff from glass and electronics production wastes
Barium	2017	0.06	0.04 to 0.07	6	ppm	2	2	No	Discharge of drilling wastes; discharge from metal refineries; erosion of natural deposits
Fluoride	2017	0.74	0.31 to 1.6	3	ppm	4	4	No	Erosion of natural deposits; water additive which promotes strong teeth; discharge from fertilizer and aluminum factories
Nitrate	2017	6.94	0 to 9.3	9	ppm	10	10	No	Runoff from fertilizer use; leaching from septic tanks, sewage; erosion of natural deposits
Selenium	2017	4.33	0 to 8	6	ppb	50	50	No	Discharge from petroleum and metal refineries; erosion of natural deposits; discharge from mines

**Nitrate:** *Nitrate in drinking water at levels above 10 ppm* is a health risk for infants of less than six months of age. High nitrate levels in drinking water can cause blue baby syndrome. Nitrate levels may rise quickly for short periods of time because of rainfall or agricultural activity. If you are caring for an infant you should ask advice from your health care provider.

**Secondary Contaminants\*\***

\*\*Secondary standards are non-enforceable guidelines for contaminants that may cause cosmetic effects (such as skin, or tooth discoloration) or aesthetic effects (such as taste, odor, or color) in drinking water.

Contaminant Name	Year	Average	Range Low – High	Sample Size	Unit of Measure	Secondary Standard
Sodium	2017	49.82	21.1 to 73.2	6	ppm	N/A
Total Dissolved Solids	2017	337.7	248 - 472	16	ppm	500

**Violations, Significant Deficiencies, Backflow/Cross-Connection, and Formal Enforcement Actions**

Violations					
Name	Category	Time Period	Health Effects	Compliance Value	TT Level or MCL
CROSS CONNECTION RULE	FAILURE TO MEET CROSS CONNECTION/BACKFLOW REQUIREMENTS - HEALTH-BASED	01/01/2017 - 06/12/2017	May pose a risk to public health.	N/A	N/A
<b>Additional Violation Information</b>					
<p>*Please share this information with all the other people who drink this water, especially those who may not have received this notice directly (for example, people in apartments, nursing homes, schools, and businesses). You can do this by posting this notice in a public place or distributing copies by hand or mail.*</p> <p>Explanation of the violation(s), the steps taken to resolve them, and the anticipated resolved date:</p>					

Backflow and Cross-Connection
<p>Cherokee Metropolitan District had an inadequate backflow prevention and cross-connection control program in 2016 and failed to meet the specified percentage of backflow device testing required by the Colorado Department of Public Health and Environment. The District is currently in compliance with the Cross Connection Rule. Uncontrolled cross connections can lead to inadvertent contamination of the drinking water.</p>

**Appendix B**

**Cherokee Metropolitan District letter of commitment**



## CHEROKEE METROPOLITAN DISTRICT

6250 Palmer Park Blvd., Colorado Springs, CO 80915-2842

Telephone: (719) 597-5080 Fax: (719) 597-5145

August 3, 2018

Mr. Heath Herber  
c/o Mule Deer Investments  
31 N. Tejon Street  
Suite 532  
Colorado Springs, CO 80903

Re: Residential Development – The Gardens at North Carefree  
Commitment Letter #2018-07 (revision of Commitment Letter #2018-03)

Dear Mr. Herber

As requested, this letter is being provided as a formal Letter of Commitment by the Cherokee Metropolitan District (District) to provide municipal water and sewer service for the above-mentioned development. Since the development has been revised from 125 townhomes to 71 single family homes, this commitment letter is a revision of Commitment Letter #2018-03 that was issued on April 20, 2018 by Kurt Schlegel. The parcel of land is located within the District's service boundary and, therefore, the District stands ready and willing to provide water and sewer service for the specific property and uses detailed herein.

As of October 2015, the State Engineer's Office has given the District a favorable opinion on the District's quantification of water supplies available for new subdivisions and commercial developments. The State Engineer confirmed, through a Technical Memorandum prepared by Forsgren Associates, that the District had a surplus of 453 acre feet per year of water available for new developments as of May 18, 2016. Since that time, the District has issued 83.829 acre feet per year of water commitments leaving a balance of 369.171 acre feet per year of water for future developments. The Gardens at North Carefree development requires 22.010 acre feet per year of water leaving the District with a water balance of 347.161 acre feet per year for future developments.

Regarding the wastewater capacity, the District's Water Reclamation Facility (WRF) has the required capacity to meet the sewer demand for this development. The WRF is rated for 4.8 million gallons per day (MGD), of which 2.6 MGD is owned by the District and reserved for District's customers. The District's current contribution to the WRF is 1.560 MGD with a committed capacity of 1.593 MGD, therefore, there is an excess of 1.040 MGD of treatment capacity available and 1.007 MGD of

available capacity for future commitments. Based on the information received in the "Engineering Study for The Gardens at North Carefree Wastewater System Improvements" report dated July 2018 by Stantec, this development is estimated to discharge 15,718 gallons of wastewater per day which equates to 1.56% of the available capacity of the WRF leaving 0.991 MGD of capacity available for future developments.

This water commitment is hereby made exclusively for this specific development project at this site, within the District, and must achieve appropriate zoning and a final plat land use entitlement from El Paso County Development Services within 12 months from the date of this letter; otherwise, the District may use this allocation for other developments requesting a water commitment for growth that stands ready to develop.

The District and I trust that you find this letter adequate for your needs and land use applications. If I may be of further assistance, please contact me at your convenience.

Best Regards,



Jonathon Smith  
Water & Wastewater Collections Manager

Encl: Water Balance and Water Commitments (Cherokee Metropolitan District)  
Commitment Letter #2018-03 for Mule Deer Villas (dated April 20, 2018)  
Water Supply Information Summary for The Gardens at North Carefree  
Water System Improvements for The Gardens at North Carefree; pages #1 and #9  
Wastewater System Improvements for The Gardens at North Carefree; pages #1 and #4  
Vicinity Map for The Gardens at North Carefree  
Site Utilities Plan for The Gardens at North Carefree

Ec: Brian Beaudette, Interim General Manager, Cherokee Metropolitan District  
Charles Cothorn, Senior Project Manager, Stantec  
Erin Ganaway, Project Engineer, N.E.S. Inc.

## Water Balance and Water Commitments (Cherokee Metropolitan District)

<u>Development</u>	<u>Business Name</u>	<u>Address</u>	<u>Commitment Letter</u>	<u>Date</u>	<u>Acres</u>
SEC Marksheffel Road and Constitution Avenue Phase #2	SEC Marksheffel Road and Constitution Avenue Phase #2	SEC Marksheffel Road and Constitution Avenue	2015-01	Expired	-4.460
Windermere Filing #1	Windermere Subdivision Filing #1	NEC Anteloper Ridge Drive and N. Carefree Circle	2015-02	Expired	-22.210
Constitution Apartment Complex	Constitution Apartments	6855 Constitution Avenue	2016-01	Expired	-19.000
Meadowbrook Crossing Subdivision	Meadowbrook Crossing	Meadowbrook Parkway and Highway 24	2017-01	5/4/2017	36.270
Kum & Go Store #692	Kum & Go	6809 Space Village Avenue	2017-02	9/8/2017	2.072
Freedom Springs Apartment Complex	Freedom Springs	734 Western Drive	2018-01	2/22/2018	14.500
Covert Ops Paintball	Covert Ops Paintball	6425 E. Platte Avenue	2018-02	3/22/2018	0.150
Mule Deer Villas Subdivision	Mule Deer Villas	SEC Akers Drive and N. Carefree Circle	2018-03	4/20/2018	36.250
Mule Deer Villas Subdivision	Mule Deer Villas	SEC Akers Drive and N. Carefree Circle	2018-03	Revised	-36.250
Appaloosa Highway 24 Subdivision Filing #2	Appaloosa Highway 24 Subdivision Filing #2	SEC Amelia Street & Terminal Avenue	2018-04	6/13/2018	1.247
SEC Marksheffel Road and Constitution Avenue Phase #2	SEC Marksheffel Road and Constitution Avenue Phase #2	SEC Marksheffel Road and Constitution Avenue	2018-05	7/6/2018	4.460
Windermere Subdivision	Windermere	NEC Anteloper Ridge Drive and N. Carefree Circle	2018-06	7/6/2018	70.800
Gardens at North Carefree Subdivision (Mule Deer Villas)	Gardens at North Carefree	SEC Akers Drive and N. Carefree Circle	2018-07	8/3/2018	22.010

Water Balance Beginning as of May 18, 2016 (AFY) **453.000**

Water Committed since May 18, 2016 (AFY) **105.839**

Water Balance Remaining for Future Commitments (AFY) **347.161**