

EL PASE COUNTY CONSTRUCTION PLANS STANDARD NOTES:

SEE SHEET 2

CHEROKEE METROPOLITAN DISTRICT WATER PLAN APPROVAL:

THE CHEROKEE METROPOLITAN DISTRICT RECOGNIZES THE DESIGN PROFESSIONAL OF RECORD AS THE LICENSED ENGINEER HAVING RESPONSIBILITY FOR THE SUBMITTED DESIGN AND THE DISTRICT HAS LIMITED ITS SCOPE OF REVIEW ACCORDINGLY. AS SUCH, THE APPROVAL GRANTED HEREIN IS FOR THE CONSTRUCTION OF THE FACILITIES AS REPRESENTED ON THESE DOCUMENTS. APPROVAL EXPIRES ONE (1) YEAR FROM THE DATE BELOW AND RESUBMITTAL OF THESE PLANS FOR REVIEW AND APPROVAL IS REQUIRED IF CONSTRUCTION DOES NOT BEGIN DURING THIS PERIOD.

APPROVED BY: _____ DATE: _____

CHEROKEE METROPOLITAN DISTRICT WASTEWATER PLAN APPROVAL:

THE CHEROKEE METROPOLITAN DISTRICT RECOGNIZES THE DESIGN PROFESSIONAL OF RECORD AS THE LICENSED ENGINEER HAVING RESPONSIBILITY FOR THE SUBMITTED DESIGN AND THE DISTRICT HAS LIMITED ITS SCOPE OF REVIEW ACCORDINGLY. AS SUCH, THE APPROVAL GRANTED HEREIN IS FOR THE CONSTRUCTION OF THE FACILITIES AS REPRESENTED ON THESE DOCUMENTS. APPROVAL EXPIRES ONE (1) YEAR FROM THE DATE BELOW AND RESUBMITTAL OF THESE PLANS FOR REVIEW AND APPROVAL IS REQUIRED IF CONSTRUCTION DOES NOT BEGIN DURING THIS PERIOD.

APPROVED BY: _____ DATE: _____

FIRE DEPARTMENT APPROVAL:

ALL FIRE HYDRANTS SHALL BE INSTALLED ACCORDING TO SPECIFICATIONS THE NUMBER OF FIRE HYDRANTS AND HYDRANT LOCATIONS AS SHOWN ON THIS WATER INSTALLATION PLAN ARE CORRECT AND ADEQUATE TO SATISFY THE FIRE PROTECTION REQUIREMENTS AS SPECIFIED BY THE FALCON FIRE DEPARTMENT.

SIGNED: _____ DATE: _____
FALCON FIRE DEPARTMENT

COUNTY PLAN REVIEW IS PROVIDED ONLY FOR GENERAL CONFORMANCE WITH COUNTY DESIGN CRITERIA. THE COUNTY IS NOT RESPONSIBLE FOR THE ACCURACY AND ADEQUACY OF THE DESIGN, DIMENSIONS, AND/OR ELEVATIONS WHICH SHALL BE CONFIRMED AT THE JOB SITE. THE COUNTY THROUGH THE APPROVAL OF THIS DOCUMENT ASSUMES NO RESPONSIBILITY FOR COMPLETENESS AND/OR ACCURACY OF THIS DOCUMENT.

FILED IN ACCORDANCE WITH THE REQUIREMENTS OF THE EL PASO COUNTY LAND DEVELOPMENT CODE, DRAINAGE CRITERIA, AND ENGINEERING CRITERIA MANUAL AS AMENDED.

IN ACCORDANCE WITH ECM SECTION 1.12, THESE CONSTRUCTION DOCUMENTS WILL BE VALID FOR CONSTRUCTION FOR A PERIOD OF 2 YEARS, FROM THE DATE SIGNED BY THE EL PASO COUNTY ENGINEER. IF CONSTRUCTION HAS NOT STARTED WITHIN THOSE 2 YEARS, THE PLANS WILL NEED TO BE RESUBMITTED FOR APPROVAL, INCLUDING PAYMENT OF REVIEW FEES AT THE PLANNING AND COMMUNITY DEVELOPMENT DIRECTORS DISCRETION.

JENNIFER IRVINE, P.E. _____ DATE: _____

COUNTY ENGINEER/ECM ADMINISTRATOR

LEGAL DESCRIPTION:

BEING LOT 2, MULE DEER BUSINESS PARK FILING NO. 1 AND A TRACT OF LAND LOCATED IN THE EAST 1/2 OF SECTION 29, TOWNSHIP 13 SOUTH, RANGE 65 WEST OF THE 6TH PRINCIPAL MERIDIAN, EL PASO COUNTY COLORADO, MORE PARTICULARLY DESCRIBED AS FOLLOWS:

BEGINNING AT THE NORTHEAST CORNER OF AKERS DRIVE (80 FEET WIDE) AS PLATTED IN MULE DEER BUSINESS PARK FILING NO. 1, RECORDED WITH RECEPTION NO. 206712353 IN THE RECORDS OF THE EL PASO COUNTY CLERK AND RECORDER, POINT BEING ON THE SOUTHERLY RIGHT-OF-WAY OF NORTH CAREFREE CIRCLE (120 FEET WIDE) AS PLATTED IN PRONGHORN MEADOWS FILING NO. 1, RECORDED WITH RECEPTION NO. 202165571 OF SAID RECORDS:

THE FOLLOWING FIVE (5) COURSES ARE ON THE EASTERLY RIGHT-OF-WAY OF SAID AKERS DRIVE;

- 1) THENCE S00°41'40"E A DISTANCE OF 552.96 FEET TO A POINT OF CURVE TO THE LEFT;
 - 2) THENCE ON THE ARC OF SAID CURVE, HAVING A RADIUS OF 980.00 FEET, A DELTA ANGLE OF 04°35'19", AN ARC LENGTH OF 76.88 FEET, WHOSE LONG CHORD BEARS S02°59'19"E A DISTANCE OF 76.86 FEET;
 - 3) THENCE S05°16'59"E A DISTANCE OF 277.56 FEET TO THE NORTHWEST CORNER OF LOT 2, OF SAID MULE DEER BUSINESS PARK FILING NO. 1;
 - 4) THENCE S05°16'59"E ON THE WESTERLY LINE OF SAID LOT 2, A DISTANCE OF 142.31 FEET TO A POINT OF CURVE TO THE RIGHT;
 - 5) THENCE ON THE ARC OF SAID CURVE AND SAID WESTERLY LINE OF LOT 2, HAVE A RADIUS OF 1040.00 FEET, A DELTA ANGLE OF 03°59'26", AN ARC LENGTH OF 72.43 FEET, WHOSE LONG CHORD BEARS S03°17'16"E A DISTANCE OF 72.42 FEET TO THE SOUTHWEST CORNER OF SAID LOT 2;
- THENCE N88°42'27"E ON THE SOUTH LINE OF SAID LOT 2, A DISTANCE OF 413.10 FEET TO THE SOUTHEAST CORNER OF SAID LOT 2;
- THENCE N00°02'55"E ON THE EAST LINE OF SAID LOT 2, A DISTANCE OF 209.74 FEET TO THE NORTHEAST CORNER OF SAID LOT 2;
- THENCE N00°02'55"E A DISTANCE OF 906.69 FEET TO A POINT ON THE SOUTHERLY RIGHT-OF-WAY OF SAID NORTH CAREFREE CIRCLE;
- THENCE S89°18'20"W ON SAID SOUTHERLY RIGHT-OF-WAY, A DISTANCE OF 467.50 FEET TO THE POINT OF BEGINNING.

THE ABOVE TRACT OF LAND CONTAINS 503,669 SQUARE FEET OR 11.563 ACRES, MORE OR LESS.

THE GARDENS AT NORTH CAREFREE

CONSTRUCTION DRAWINGS

EL PASO COUNTY, STATE OF COLORADO

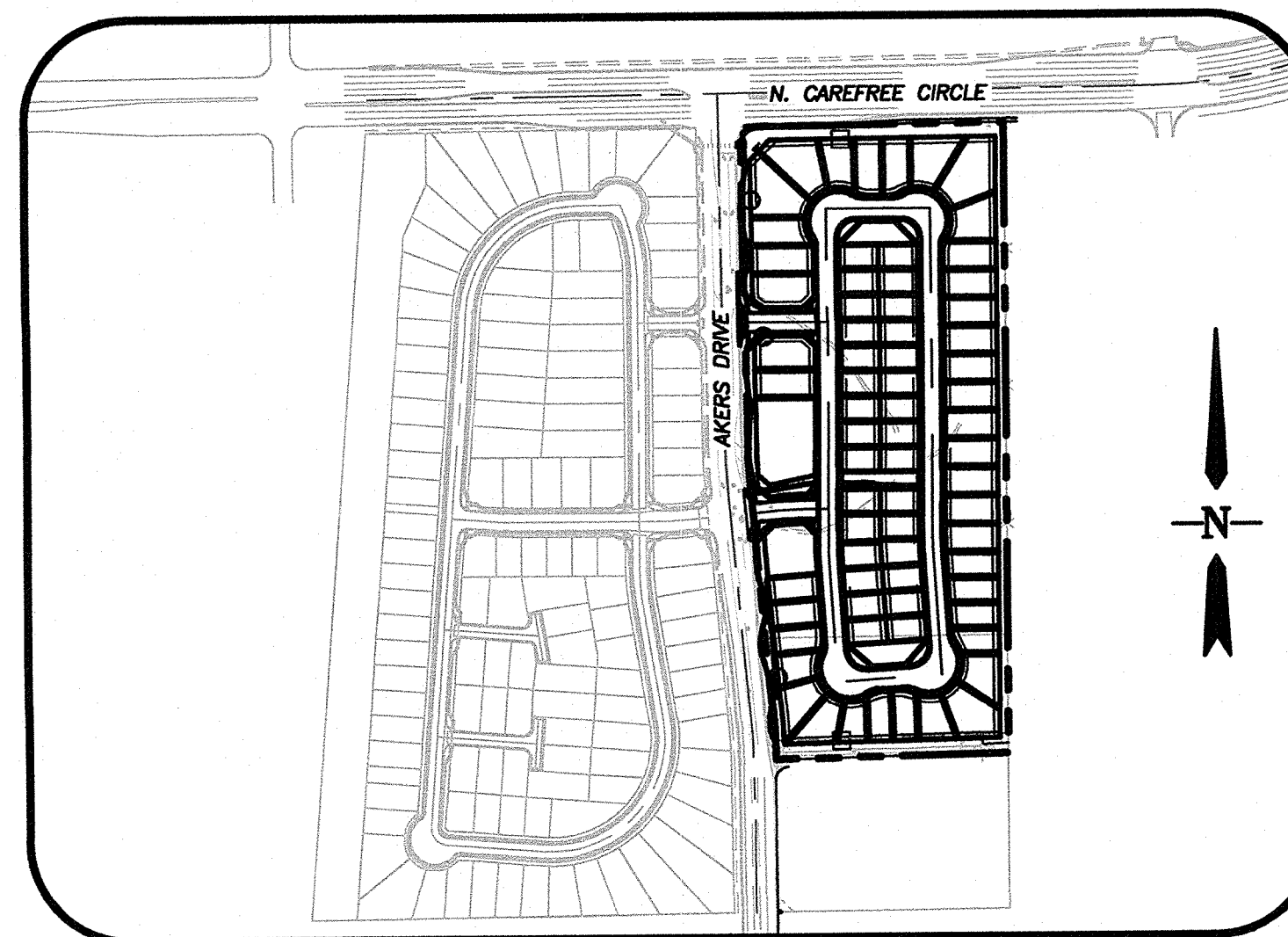

LOCATION MAP
SCALE: 1"=300'

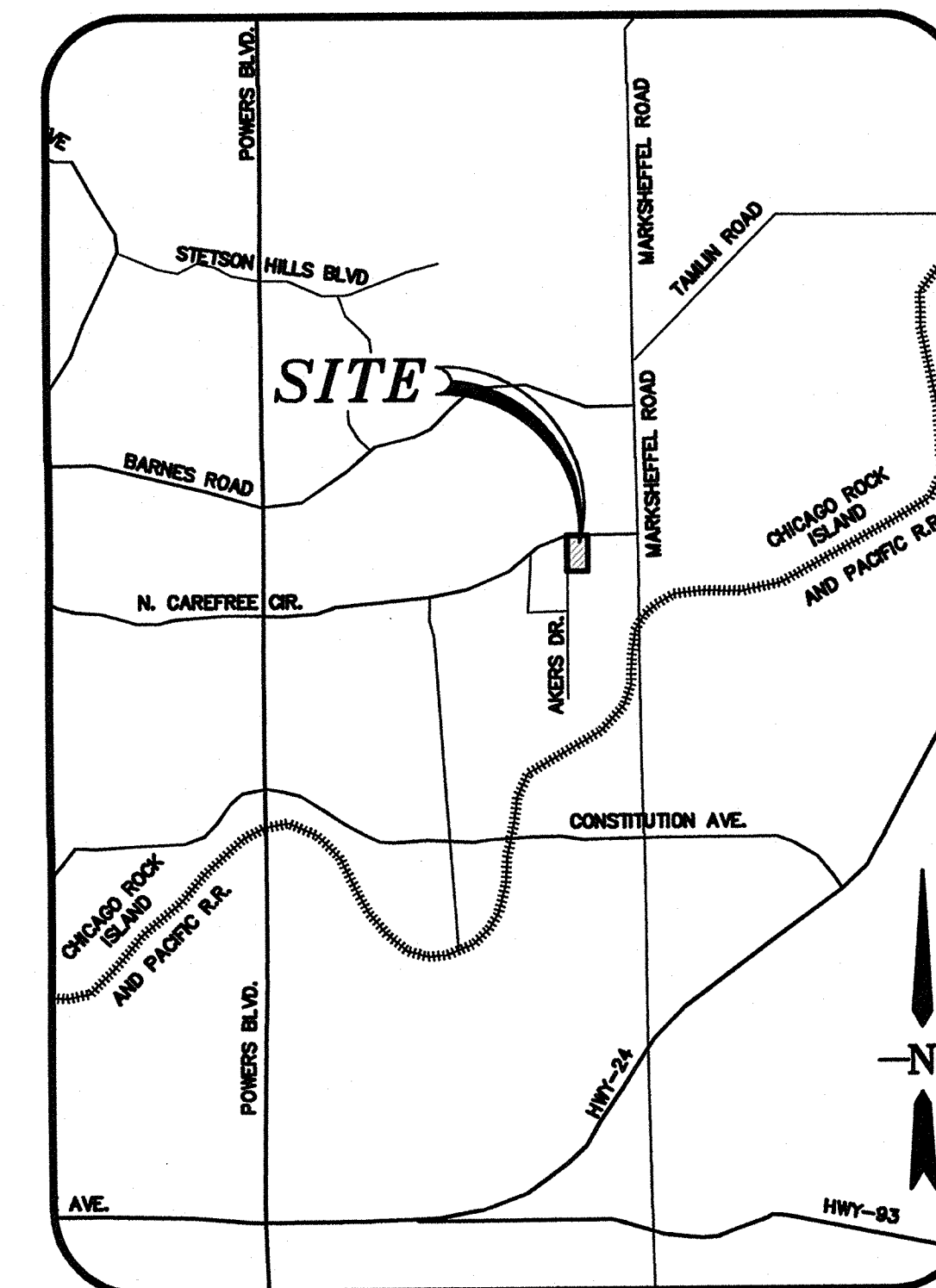

VICINITY MAP
N.T.S.

NOTES:
45' URBAN LOCAL RESIDENTIAL PER APPROVED DEVIATION FROM PRELIMINARY PLAN PUDSP184.

ANY PROPOSED MODIFICATION TO THE APPROVED GRADING AND EROSION CONTROL PLAN MUST BE SUBMITTED, ALONG WITH SUPPORTING DOCUMENTS, TO THE COUNTY ENGINEER FOR APPROVAL PRIOR TO ANY WORK RELATED TO THE PROPOSED MODIFICATION TAKING PLACE. APPROVAL FROM THE COUNTY ENGINEER SHALL BE ISSUED IF THE APPLICANT DEMONSTRATES THAT THE MODIFICATION WILL PROVIDE SOIL EROSION CONTROLS EQUIVALENT TO OR EXCEEDING THOSE OF THE PREVIOUSLY APPROVED GRADING AND EROSION CONTROL PLAN.

DEVELOPERS STATEMENT:
I, THE OWNER/DEVELOPER HAVE READ AND WILL COMPLY WITH ALL OF THE REQUIREMENTS SPECIFIED IN THESE DETAILED PLANS AND SPECIFICATIONS.

Heath A. Herber, manager 12/19/19
DEVELOPER: MULE DEER INVESTMENTS, LLC DATE: _____
HEATH HERBER, AUTHORIZED AGENT
31 N. TEJON STREET, SUITE 502
COLORADO SPRINGS, CO 80903

THESE DETAILED PLANS AND SPECIFICATIONS WERE PREPARED UNDER MY DIRECTION AND SUPERVISION. SAID PLANS AND SPECIFICATIONS HAVE BEEN PREPARED ACCORDING TO THE CRITERIA ESTABLISHED BY THE COUNTY FOR DETAILED ROADWAY, DRAINAGE, GRADING AND EROSION CONTROL PLANS AND SPECIFICATIONS, AND SAID PLANS AND SPECIFICATIONS ARE IN CONFORMITY WITH APPLICABLE MASTER DRAINAGE PLANS AND MASTER TRANSPORTATION PLANS. SAID PLANS AND SPECIFICATIONS MEET THE PURPOSE FOR WHICH THE PARTICULAR ROADWAY AND DRAINAGE FACILITIES ARE DESIGNED AND ARE CORRECT TO THE BEST OF MY KNOWLEDGE AND BELIEF. I ACCEPT RESPONSIBILITY FOR ANY LIABILITY CAUSED BY ANY NEGLIGENT ACTS, ERRORS OR OMISSIONS ON MY PART IN PREPARATION OF THESE DETAILED PLANS AND SPECIFICATIONS.

THESE PLANS WERE PREPARED ON BEHALF OF SPRINGS ENGINEERING UNDER THE SUPERVISION OF:

Charles K. Cothern _____ DATE: 12/19/19
CHARLES K. COTHERN, P.E.
PROFESSIONAL ENGINEER

PCD FILE No. SF 195

SHEET INDEX

1	TITLE SHEET
2	GENERAL NOTES & DETAIL SHEET
3	TYPICAL SECTIONS
4	SITE PLAN
5	PLAN AND PROFILE-VINEYARD CIRCLE
6	PLAN AND PROFILE-VINEYARD CIRCLE
7	PLAN AND PROFILE-FALLOW LAND AND RUNNING DEER WAY
8-9	PLAN & PROFILE - KNUCKLES
10-11	INTERSECTION DETAILS
12	PLAN & PROFILE - TRAIL
13-16	PLAN & PROFILE - SIDEWALKS
17-21	PLAN & PROFILE - WALLS
22-23	PLAN AND PROFILE-STORM SEWERS
24-25	NORTH WQ POND
26-27	SOUTH WQ POND
28	GRADING AND EROSION CONTROL PLAN
29-32	GRADING EROSION CONTROL NOTES AND DETAIL
33	MASTER UTILITY PLAN
34	SIGNING AND STRIPING

CONTACT INFORMATION:

OWNER / DEVELOPER:
MULE DEER INVESTMENTS LLC
31 N. TEJON STREET, SUITE 502
COLORADO SPRINGS, CO 80903

ENGINEER / PLANNER:
STANTEC CONSULTING INC.
5725 MARK DABLING BLVD, SUITE 1901
COLORADO SPRINGS, CO 80919

WATER & SANITARY SEWER:
CHEROKEE METROPOLITAN DISTRICT
(719)597-5080

ELECTRIC:
MOUNTAIN VIEW ELECTRIC ASSOCIATION
(719)495-2283

GAS:
COLORADO SPRINGS UTILITIES
(719)448-4800

STREET:
EL PASO COUNTY PUBLIC SERVICES
DEPARTMENT
(719)560-6460

DRAINAGE:
EL PASO COUNTY PUBLIC
SERVICES DEPARTMENT
(719)520-6460

Computer File Information		Index of Revisions	
Creation Date: 4-25-17	Initials: CMD		
Last Modification Date:	Initials:		
Full Path & Drawing File Name:			
Acad Ver. 2014	Scale:	Units:	Feet

GARDENS AT NORTH CAREFREE		Project No./Code	
TITLE SHEET		187608744	
Designer: CD	Structure Numbers		
Detailer: MB			
Sheet Subset:		SHEET 1 OF 34	

EL PASO COUNTY CONSTRUCTION PLANS STANDARD NOTES

- ALL DRAINAGE AND ROADWAY CONSTRUCTION SHALL MEET THE STANDARDS AND SPECIFICATIONS OF THE CITY OF COLORADO SPRINGS/EL PASO COUNTY DRAINAGE CRITERIA MANUAL, VOLUMES 1 AND 2, AND THE EL PASO COUNTY ENGINEERING CRITERIA MANUAL.
- CONTRACTOR SHALL BE RESPONSIBLE FOR THE NOTIFICATION AND FIELD LOCATIONS OF ALL EXISTING UTILITIES, WHETHER SHOWN ON THE PLANS OR NOT, BEFORE BEGINNING CONSTRUCTION. LOCATION OF EXISTING UTILITIES SHALL BE VERIFIED BY THE CONTRACTOR PRIOR TO CONSTRUCTION. CALL 811 TO CONTACT THE UTILITY NOTIFICATION CENTER OF COLORADO (UNCC).
- CONTRACTOR SHALL KEEP A COPY OF THESE APPROVED PLANS, THE GRADING AND EROSION CONTROL PLAN, THE STORMWATER MANAGEMENT PLAN (SWMP), THE SOILS AND GEOTECHNICAL REPORT, AND THE APPROPRIATE DESIGN AND CONSTRUCTION STANDARDS AND SPECIFICATIONS AT THE JOB SITE AT ALL TIMES, INCLUDING THE FOLLOWING:
 - EL PASO COUNTY ENGINEERING CRITERIA MANUAL (ECM)
 - CITY OF COLORADO SPRINGS/EL PASO COUNTY DRAINAGE CRITERIA MANUAL, VOLUMES 1 AND 2
 - COLORADO DEPARTMENT OF TRANSPORTATION (CDOT) STANDARD SPECIFICATIONS FOR ROAD AND BRIDGE CONSTRUCTION
 - CDOT M & S STANDARDS
- NOT WITHSTANDING ANYTHING DEPICTED IN THESE PLANS IN WORDS OR GRAPHIC REPRESENTATION, ALL DESIGN AND CONSTRUCTION RELATED TO ROADS, STORM DRAINAGE AND EROSION CONTROL SHALL CONFORM TO THE STANDARDS AND REQUIREMENTS OF THE MOST RECENT VERSION OF EL PASO COUNTY STANDARDS, INCLUDING THE LAND DEVELOPMENT CODE, THE ENGINEERING CRITERIA MANUAL, THE DRAINAGE CRITERIA MANUAL, AND THE DRAINAGE CRITERIA MANUAL VOLUME 2. ANY DEVIATIONS FROM REGULATIONS AND STANDARDS MUST BE REQUESTED AND APPROVED, IN WRITING. ANY MODIFICATIONS NECESSARY TO MEET CRITERIA AFTER-THE-FACT WILL BE ENTIRELY THE DEVELOPER'S RESPONSIBILITY TO RECTIFY.
- IT IS THE DESIGN ENGINEER'S RESPONSIBILITY TO ACCURATELY SHOW EXISTING CONDITIONS, BOTH ONSITE AND OFFSITE, ON THE CONSTRUCTION PLANS. ANY MODIFICATIONS NECESSARY DUE TO CONFLICTS, OMISSIONS, OR CHANGED CONDITIONS WILL BE ENTIRELY THE DEVELOPER'S RESPONSIBILITY TO RECTIFY.
- CONTRACTOR SHALL SCHEDULE A PRE-CONSTRUCTION MEETING WITH EL PASO COUNTY PLANNING AND COMMUNITY DEVELOPMENT DEPARTMENT (PCD) - INSPECTIONS, PRIOR TO STARTING CONSTRUCTION.
- IT IS THE CONTRACTOR'S RESPONSIBILITY TO UNDERSTAND THE REQUIREMENTS OF ALL JURISDICTIONAL AGENCIES AND TO OBTAIN ALL REQUIRED PERMITS, INCLUDING BUT NOT LIMITED TO EL PASO COUNTY EROSION AND STORMWATER QUALITY CONTROL PERMIT (ESQCP), REGIONAL BUILDING FLOODPLAIN DEVELOPMENT PERMIT, U.S. ARMY CORPS OF ENGINEERS-ISSUED 401 AND/OR 404 PERMITS, AND COUNTY AND STATE FUGITIVE DUST PERMITS.
- CONTRACTOR SHALL NOT DEVIATE FROM THE PLANS WITHOUT FIRST OBTAINING WRITTEN APPROVAL FROM THE DESIGN ENGINEER AND PCD. CONTRACTOR SHALL NOTIFY THE DESIGN ENGINEER IMMEDIATELY UPON DISCOVERY OF ANY ERRORS OR INCONSISTENCIES.
- ALL STORM DRAIN PIPE SHALL BE CLASS III RCP UNLESS OTHERWISE NOTED AND APPROVED BY PCD.
- CONTRACTOR SHALL COORDINATE GEOTECHNICAL TESTING PER ECM STANDARDS. PAVEMENT DESIGN SHALL BE APPROVED BY EL PASO COUNTY PCD PRIOR TO PLACEMENT OF CURB AND GUTTER AND PAVEMENT.
- ALL CONSTRUCTION TRAFFIC MUST ENTER/EXIT THE SITE AT APPROVED CONSTRUCTION ACCESS POINTS.
- SIGHT VISIBILITY TRIANGLES AS IDENTIFIED IN THE PLANS SHALL BE PROVIDED AT ALL INTERSECTIONS. OBSTRUCTIONS GREATER THAN 18 INCHES ABOVE FLOWLINE ARE NOT ALLOWED WITHIN SIGHT TRIANGLES.
- SIGNING AND STRIPING SHALL COMPLY WITH EL PASO COUNTY DEPARTMENT OF PUBLIC WORKS (DPW) AND MUTCD CRITERIA. [IF APPLICABLE, ADDITIONAL SIGNING AND STRIPING NOTES WILL BE PROVIDED.]
- CONTRACTOR SHALL OBTAIN ANY PERMITS REQUIRED BY EL PASO COUNTY DPW, INCLUDING WORK WITHIN THE RIGHT-OF-WAY AND SPECIAL TRANSPORT PERMITS.
- THE LIMITS OF CONSTRUCTION SHALL REMAIN WITHIN THE PROPERTY LINE UNLESS OTHERWISE NOTED. THE OWNER/DEVELOPER SHALL OBTAIN WRITTEN PERMISSION AND EASEMENTS, WHERE REQUIRED, FROM ADJOINING PROPERTY OWNER(S) PRIOR TO ANY OFF-SITE DISTURBANCE, GRADING, OR CONSTRUCTION.

CHEROKEE METRO UTILITY GENERAL NOTES

- ALL MATERIALS AND WORKMANSHIP SHALL BE IN CONFORMANCE WITH CHEROKEE METROPOLITAN DISTRICT STANDARDS AND THE CITY OF COLORADO SPRINGS CONSTRUCTION STANDARDS UNLESS NOTED OTHERWISE. IN THE EVENT OF CONFLICTING STANDARDS CHEROKEE METROPOLITAN DISTRICT STANDARDS SHALL GOVERN.
- ALL WATER SYSTEM MAINS PIPE MATERIAL SHALL BE POLYVINYL CHLORIDE (PVC) CLASS 200 (DR-14) PER AWWA C-900 AND ASTM D241 SPECIFICATIONS, EXCEPT WHERE NOTED. SPECIFICALLY, SECTIONS OF WATER PIPE THAT CROSS UNDER MAJOR DRAINAGE WAYS (SAND CREEK) OR MAJOR THOROUGHFARES SHALL BE DUCTILE IRON PIPE.
- ALL FITTINGS SHALL BE CONSTRUCTED OF GRAY-IRON MATERIAL AND FURNISHED WITH MECHANICAL JOINT ENDS. ALL FITTINGS SHALL HAVE A MINIMUM PRESSURE RATING OF 250 PSI AND SHALL BE WRAPPED WITH A 9-MIL THICKNESS POLYETHYLENE MATERIAL PER AWWA STANDARD C105. ALL FITTINGS SHALL HAVE ANODES CAD WELDED.
- ALL WATER PIPES SHALL BE INSTALLED AT A MINIMUM DEPTH OF FIVE (5) FEET BELOW FINISHED GRADE, WITH A MAXIMUM OF SIX (6) FEET TO TOP OF PIPE..
- ALL BENDS, TEE, FIRE HYDRANTS, BLOW-OFFS, AND PLUGS AT DEAD END MAINS SHALL BE INSTALLED WITH CONCRETE THRUST BLOCKS.
- VALVE BOXES SHALL BE TYLER SLIP; TYPE "C" CAST IRON VALVE BOX ASSEMBLY SERIES 6860 WITH NO. 160 OVAL BASE OR APPROVED EQUAL.
- ALL WATER SYSTEM COMPONENTS SHALL BE FLUSHED AND CHLORINATED PER AWWA C-601, "DISINFECTING WATER MAINS" PRIOR TO ACCEPTANCE. THE CONTRACTOR SHALL PRODUCE A 25 MG/L SOLUTION BY ADHERING CHLORINE TABLETS TO THE PIPE SECTION WITH PERMATEX CLEAR TRV INSIDE THE SYSTEM. CHLORINATION SHALL OCCUR PRIOR TO HYDROSTATIC TESTING. THE CONTRACTOR SHALL OBTAIN A BACTERIOLOGICAL SAMPLE AFTER THE SYSTEM HAS BEEN FLUSHED. A CLEAN BACTERIOLOGICAL SAMPLE MUST BE OBTAINED PRIOR TO THE SYSTEM BEING PLACED INTO SERVICE.
- HYDROSTATIC TESTING: ALL WATER SYSTEM MAINS SHALL BE FIELD PRESSURE TESTED TO A MINIMUM OF 150 PSI OR 1 1/2 TIMES THE STATIC OPERATING PRESSURE, WHICH EVER IS GREATER. MAXIMUM ALLOWABLE LEAKAGE FOR EACH SECTION OF PIPE BETWEEN LINE VALVES SHALL NOT EXCEED THE FOLLOWING: *10 GALLONS PER INCH OF PIPE DIAMETER PER MILE PER DAY.
- ALL VALVES SHALL CONFORM TO OPEN LEFT CONVENTION PER CHEROKEE METROPOLITAN DISTRICT STANDARDS.
- WHEN IT IS NECESSARY TO RAISE OR LOWER WATER MAINS AT OTHER UTILITY CROSSINGS THE CONTRACTOR SHALL INSURE A MINIMUM CLEARANCE OF 18" WHERE POSSIBLE BETWEEN THE OUTSIDE DIAMETERS OF PIPES.
- WHILE CONSTRUCTING THE WATER AND WASTE WATER SYSTEM THE CONTRACTOR SHALL HAVE IN HIS POSSESSION AT LEAST ONE APPROVED FOR CONSTRUCTION SET OF UPDATED PLANS AT ALL TIMES. APPROVED FIELD MODIFICATIONS TO PLAN SETS SHALL BE CLEARLY IDENTIFIED IN RED INK ON THE PLANS BY THE CONTRACTOR PER FIELD CONSTRUCTION. THESE AS-BUILT CHANGES SHALL BE DATED AND SUBMITTED TO THE ENGINEER OF RECORD. THE ENGINEER OF RECORD SHALL PREPARE A COMPLETE SET OF "AS CONSTRUCTED" DRAWINGS AND DELIVER THE SETS TO THE CHEROKEE METROPOLITAN DISTRICT PRIOR TO FINAL ACCEPTANCE OF THE WATER SYSTEM.
- PRIOR TO TAPPING ANY EXISTING WATER MAIN THE CONTRACTOR SHALL SUBMIT AND RECEIVE APPROVAL FOR SAID TAP IN ACCORDANCE WITH THE CHEROKEE METROPOLITAN DISTRICT STANDARDS.
- ALL NONMETALLIC PIPES SHALL HAVE A TRACER WIRE ATTACHED TO ITS TOP DURING CONSTRUCTION. THE TRACER WIRE SHALL BE #12 AWG INSULATED COPPER WIRE NO 12 COPPER CONNECTORS AND SHALL BE PERMANENTLY AFFIXED TO THE TOP OF THE PIPE USING TAPE AT 4' INTERVALS. THE TRACER WIRE SHALL ALSO BE PERMANENTLY CONNECTED TO ALL FIRE HYDRANT TEE, METALLIC PIPE BENDS, MAIN VALVE AND OTHER METALLIC FITTINGS AND APPURTENANCES. ALL POINTS OF CONNECTION SHALL BE PROTECTED FROM CORROSION BY AN EPOXY OR SILICON COATING. GROUND TRACER WIRES TO SURFACE AT ALL VALVE BOXES.
- THE CONTRACTOR ASSUMES RESPONSIBILITY FOR THE PROTECTION OF ALL UTILITIES DURING THE WORK. PRIOR TO ANY EXCAVATION, CONTACT THE UTILITY NOTIFICATION CENTER OF COLORADO AT (800) 922-1987 AT LEAST TWO WORKING DAYS PRIOR TO DIGGING.
- SANITARY SEWER PIPE SHALL CONFORM TO ASTM D3034 SDR35 PVC.
- CONTRACTOR SHALL FIELD VERIFY LOCATION AND ELEVATION OF EXISTING INVERTS PRIOR TO INSTALLATION OF NEW SANITARY SEWER SYSTEM.

PEDESTRIAN RAMP NOTES

- ALL WORK SHALL BE DONE IN ACCORDANCE WITH THE CURRENT ENGINEERING CRITERIA MANUAL AND ADA REQUIREMENTS.
- CONTRACTOR TO NOTIFY ENGINEERING DIVISION INSPECTION STAFF 48 HOURS PRIOR TO CONCRETE PLACEMENT.
- PEDESTRIAN RAMP CONSTRUCTION SHALL BE A MINIMUM 4500 PSI CONCRETE, MINIMUM 4" THICK, NON-COLORED, NON-SCORED, COARSE BROOM FINISH.
- RAMP LOCATION AND LENGTH MAY REQUIRE MODIFICATION TO MAINTAIN THE 12:1 MAXIMUM RUNNING RAMP SLOPE AND 20:1 DETECTABLE WARNING AREA DUE TO STREET INTERSECTION GRADES AND/OR ALIGNMENT.
- DETECTABLE WARNING AREA SHALL START A MINIMUM OF 6" BUT NOT MORE THAN 8" FROM THE FLOW LINE OF THE CURB AT ANY POINT.
- DETECTABLE WARNING AREA SHALL BE PREFABRICATED REDDISH INTEGRALLY COLORED TRUNCATED-DOME PAVERS. THERMOPLASTIC TRUNCATED DOMES WILL NOT BE ACCEPTABLE.
- THE DETECTABLE WARNING AREA SHALL BE 24" IN LENGTH AND THE FULL WIDTH OF THE RAMP.
- RAMP WIDTH REQUIRED IS SAME AS APPROACHING SIDEWALK; 4' MINIMUM.
- MID-BLOCK OR TERMINAL RAMP WHICH MAY BE PARALLEL SUBJECT TO APPROVAL.
- AVOID PLACING DRAINAGE STRUCTURES, TRAFFIC SIGNAL/SIGNAGE, UTILITIES/JUNCTION BOXES, OR OTHER OBSTRUCTIONS WITHIN PROPOSED RAMP AREAS.
- RAMP LOCATION AND LENGTH MAY REQUIRE MODIFICATION TO MAINTAIN THE 20:1 DETECTABLE WARNING AND 12:1 MAXIMUM RUNNING SLOPE DUE TO INTERSECTION STREET GRADES AND/OR ALIGNMENT.
- WHERE THE 1'-6" FLARED SIDE(S) OF A PERPENDICULAR CURB RAMP IS (ARE) CONTIGUOUS WITH A PEDESTRIAN OR HARD SURFACE AREA, THE FLARE WIDTH SHALL BE INCREASED TO 8' MINIMUM AND THE MAXIMUM FLARE SLOPE SHALL NOT EXCEED 10:1.
- PEDESTRIAN WALKWAY AND/OR LOCATION OF EXISTING OR FUTURE PEDESTRIAN RAMP ON OPPOSITE CORNERS SHALL BE REVIEWED BEFORE CONSTRUCTING OF NEW RAMP. NEW RAMP SHALL ALIGN WITH EXISTING RAMP AND PEDESTRIAN WALKWAY.
- AT MARKED PEDESTRIAN CROSSINGS, THE BOTTOM OF THE RAMP, EXCLUSIVE OF THE FLARE SIDE, SHALL BE TOTALLY CONTAINED WITHIN THE MARKINGS.

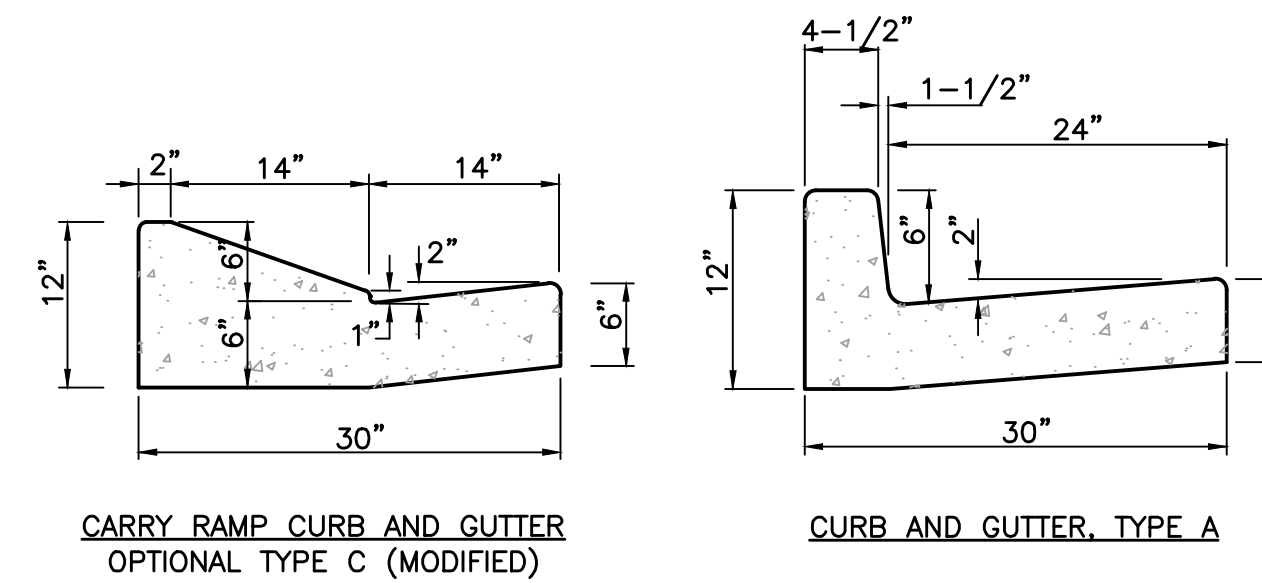
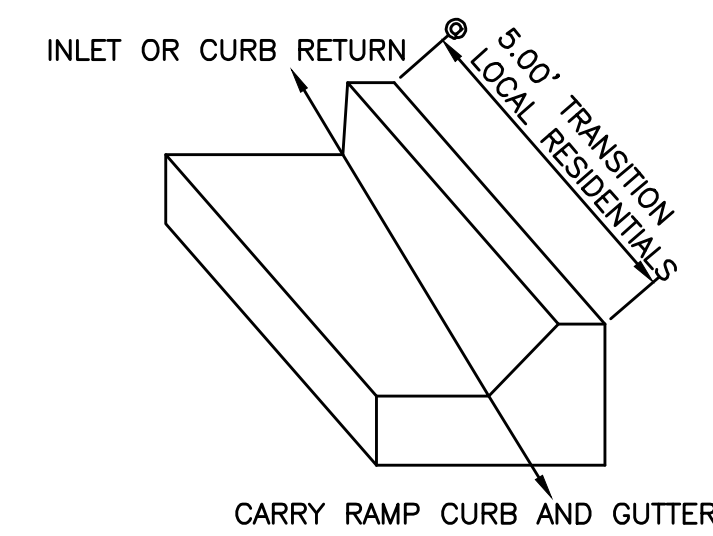

PROPOSED CURB & GUTTER

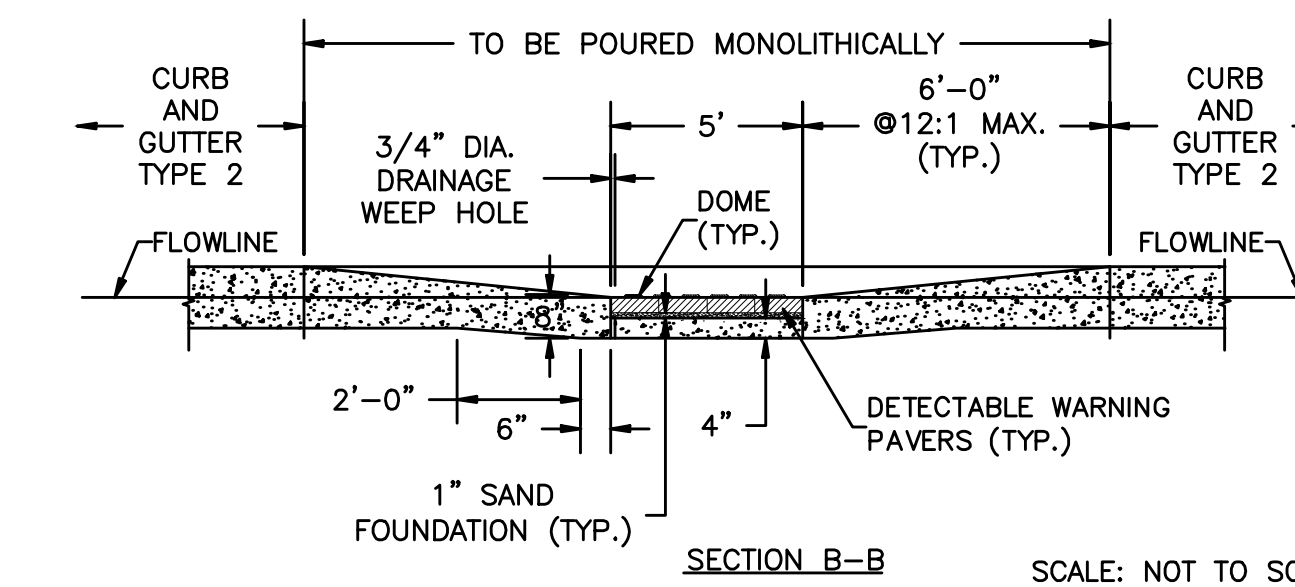
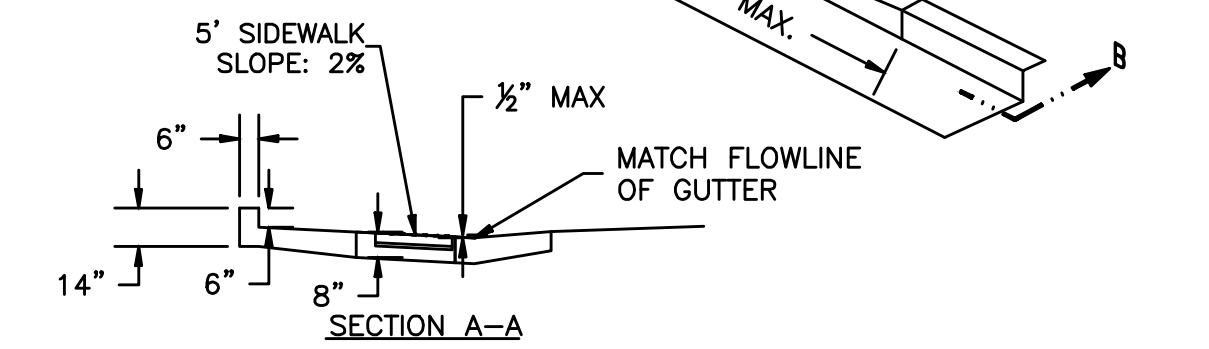
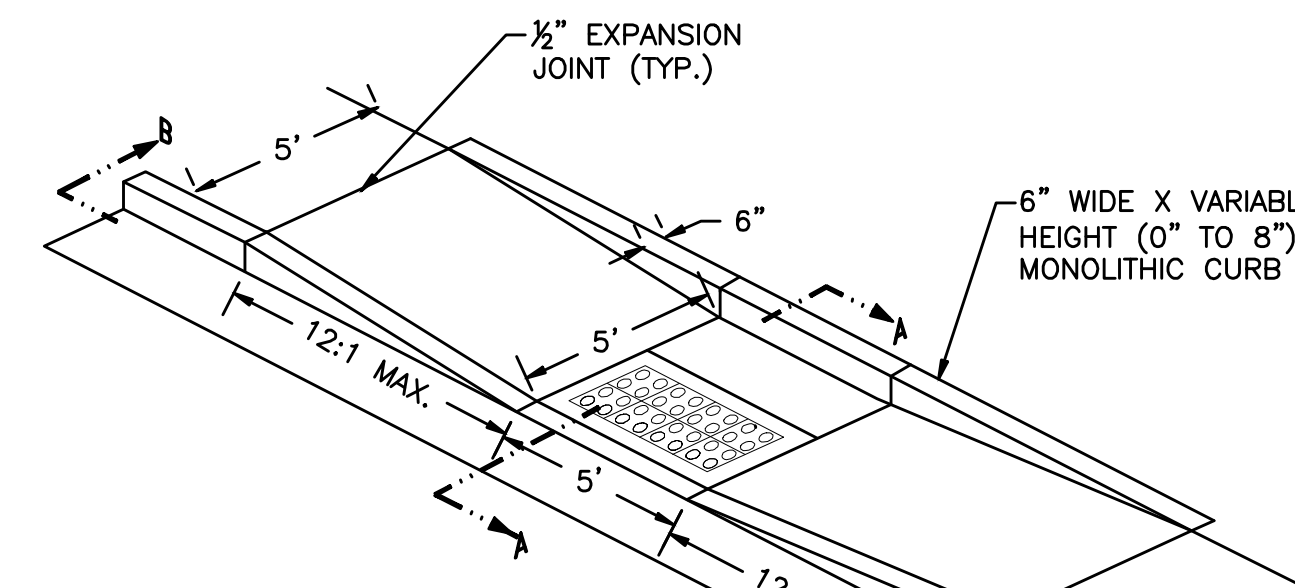

Parallel Pedestrian Ramp Detail Standard Drawing

PARALLEL PEDESTRIAN RAMP DETAIL STANDARD DRAWING

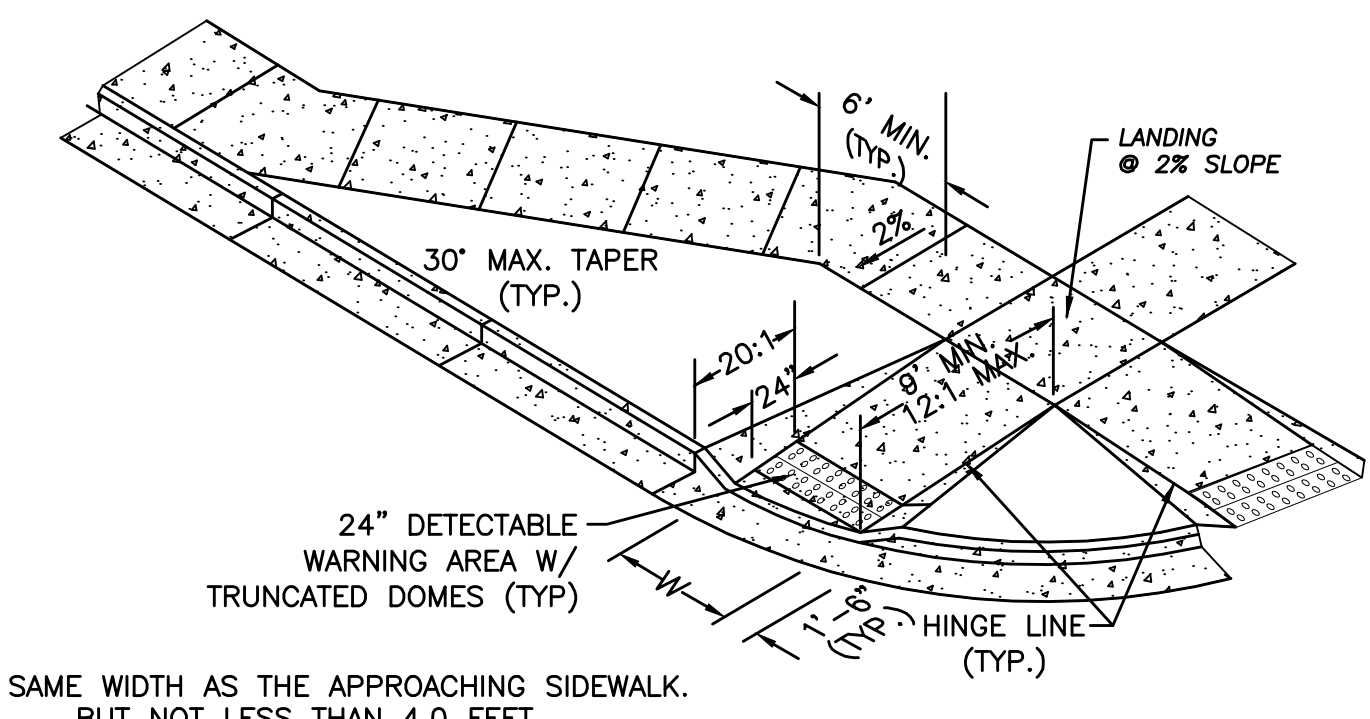

PEDESTRIAN RAMP DETAILS

NOTE: SPACING & DIMENSIONING PER EL PASO COUNTY STANDARD RAMP DETAIL SD_2-40

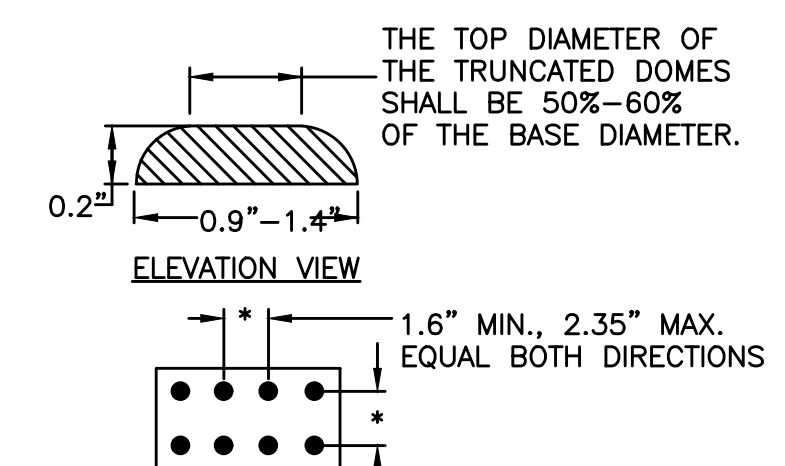

V:\52876\active\187608744\Mule Deer\CAD\Sheets\Construction Drawings\02 - Details Sheet.dwg 2019/11/21 9:37 AM By: Pearce, Taylor

Computer File Information	
Creation Date: 4-25-17	Initials: CMD
Last Modification Date:	Initials:
Full Path & Drawing File Name:	
Acad Ver. 2014	Scale: Units: Feet

Index of Revisions	

Stantec Consulting Inc.
5725 MARK DABLING BLVD
Suite 190
Colorado Springs, CO 80919
Tel. (719) 594-4535
Fax.
www.stantec.com

Designer: CD	Structure Numbers
Detailer: MB	
Sheet Subset:	

GARDENS AT NORTH CAREFREE GENERAL NOTES & DETAILS	

Project No./Code	187608744

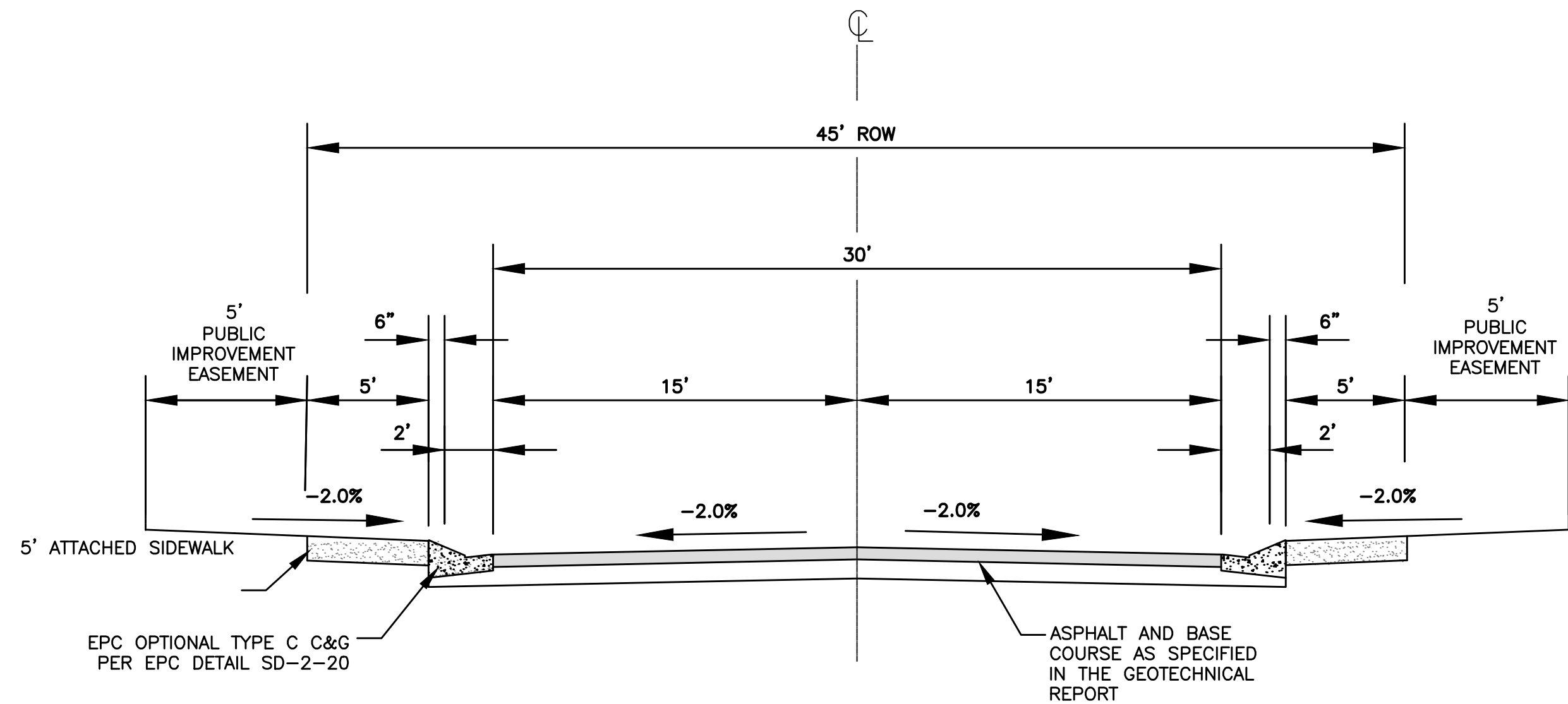

45' URBAN LOCAL RESIDENTIAL PER APPROVED DEVIATION FROM PRELIMINARY PLAN PUDSP184
DESIGN SPEED=25 MPH N.T.S.
VINEYARD CIRCLE

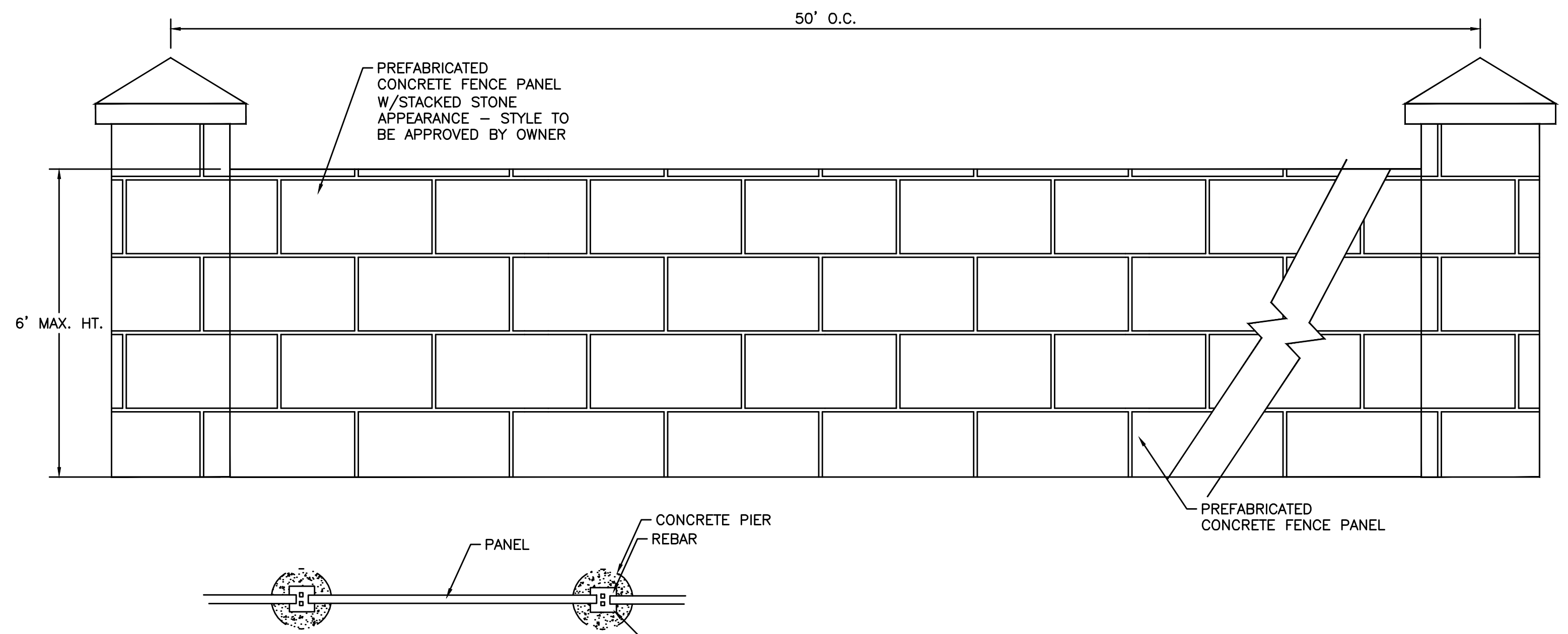

CONCRETE PANEL FENCE DETAIL N.T.S.

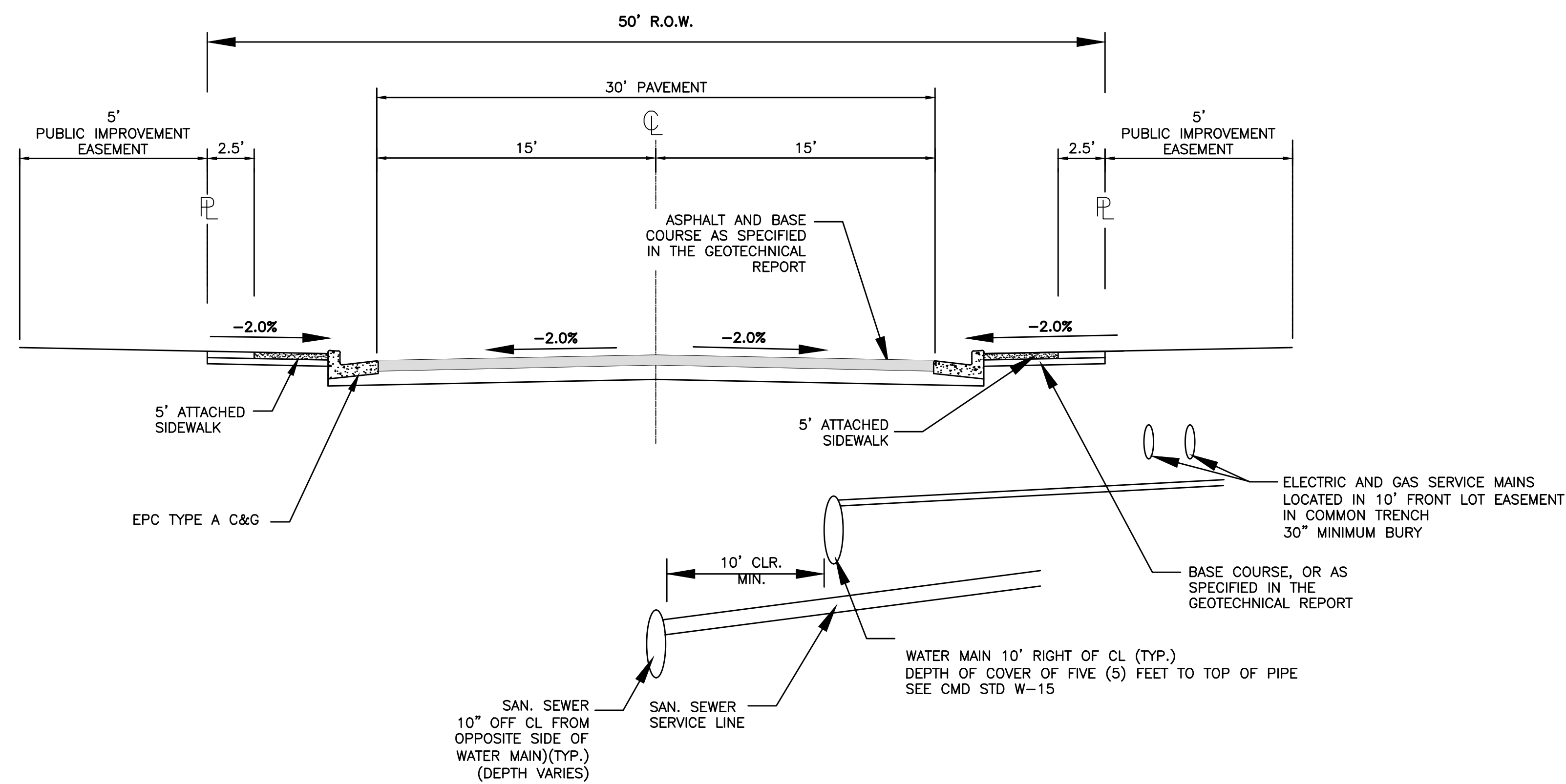

50' TYPICAL URBAN LOCAL RESIDENTIAL
DESIGN SPEED=25 MPH N.T.S.
FALLOW LANE
RUNNING DEER DRIVE

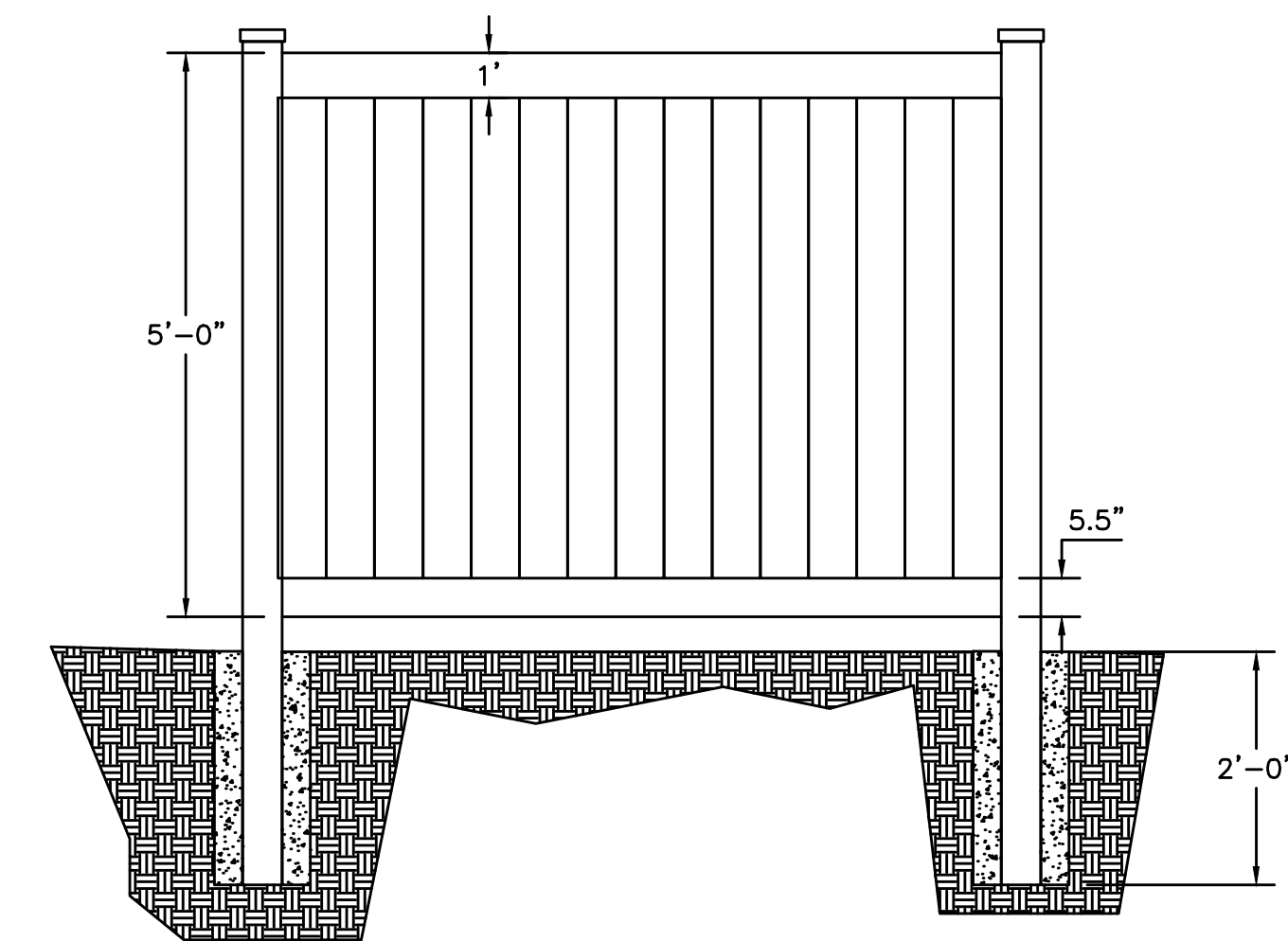

6' VINYL PRIVACY FENCE N.T.S.

V:\52876\active\187608744-Mule Deer\CAD\Sheets\Construction Drawings\02 - Details Sheet.dwg 2019/11/21 9:38 AM By: Pearce, Taylor

Computer File Information	
Creation Date: 4-25-17	Initials: CMD
Last Modification Date:	Initials:
Full Path & Drawing File Name:	
Acad Ver. 2014	Scale: Units: Feet

Index of Revisions	

Stantec Consulting Inc.
 5725 MARK DABLING BLVD
 Suite 190
 Colorado Springs, CO 80919
 Tel. (719) 594-4535
 Fax.
 www.stantec.com

GARDENS AT NORTH CAREFREE TYPICAL SECTIONS		
Designer: CD	Structure Numbers	
Detailer: MB		
Sheet Subset:		

Project No./Code
187608744
SHEET 3 OF 34

CURVE TABLE: ALIGNMENTS							START POINT (EAST, NORTH)	END POINT (EAST, NORTH)
CURVE #	START STA	END STA	RADIUS	LENGTH	CHORD DIRECTION	DELTA	(3389.07,5647.31)	(3389.99,5616.48)
C1	8+77.29	9+08.14	500.00	30.85	S1° 43' 03.05"E	3.53	(3400.77,5439.57)	(3455.83,5390.83)
C2	10+85.37	11+67.06	52.00	81.68	S48° 29' 05.68"E	90.00	(3536.68,5395.75)	(3585.42,5450.82)
C3	12+48.06	13+29.74	52.00	81.68	N41° 30' 54.32"E	90.00	(3574.07,5652.85)	(3575.00,5622.02)
C4	15+01.26	15+32.11	500.00	30.85	N1° 43' 03.05"W	3.53	(3574.53,6172.71)	(3522.57,6224.76)
C5	20+51.97	21+33.65	52.00	81.68	N44° 57' 00.42"W	90.00	(3441.57,6224.83)	(3389.53,6172.87)
C6	22+14.65	22+96.33	52.00	81.68	S45° 02' 59.58"W	90.00	(3301.69,5690.86)	(3348.16,5692.98)
C201	200+86.79	201+33.32	500.00	46.53	N87° 23' 01.39"E	5.33		

LINE TABLE: ALIGNMENTS							START POINT (EAST, NORTH)	END POINT (EAST, NORTH)
LINE #	LENGTH	START STA	END STA	DIRECTION	START POINT (EAST, NORTH)	END POINT (EAST, NORTH)	(3389.44,6074.60)	(3389.07,5647.31)
L1	427.29	4+50.00	8+77.29	S0° 02' 59.58"W	(3389.99,5616.48)	(3400.77,5439.57)	(3455.83,5390.83)	(3536.68,5395.75)
L2	177.23	9+08.14	10+85.37	S3° 29' 05.68"E	(3574.07,5652.85)	(3575.00,5622.02)	(3574.53,6172.71)	(3522.57,6224.76)
L3	81.00	11+67.06	12+48.06	N86° 30' 54.32"E	(3522.57,6224.76)	(3441.57,6224.83)	(3389.53,6172.87)	(3389.44,6074.60)
L4	171.52	13+29.74	15+01.26	N3° 29' 05.68"W	(3203.42,6024.76)	(3215.27,5682.87)	(3301.69,5690.86)	(3348.16,5692.98)
L5	519.86	15+32.11	20+51.97	N0° 02' 59.58"E				
L6	81.00	21+33.65	22+14.65	N89° 57' 00.42"W				
L7	98.27	22+96.33	23+94.61	S0° 02' 59.58"W				
L101	200.00	100+00.00	102+00.00	S89° 57' 00.42"E				
L201	86.79	200+00.00	200+86.79	N84° 43' 03.20"E				
L202	66.68	201+33.32	202+00.00	S89° 57' 00.42"E				

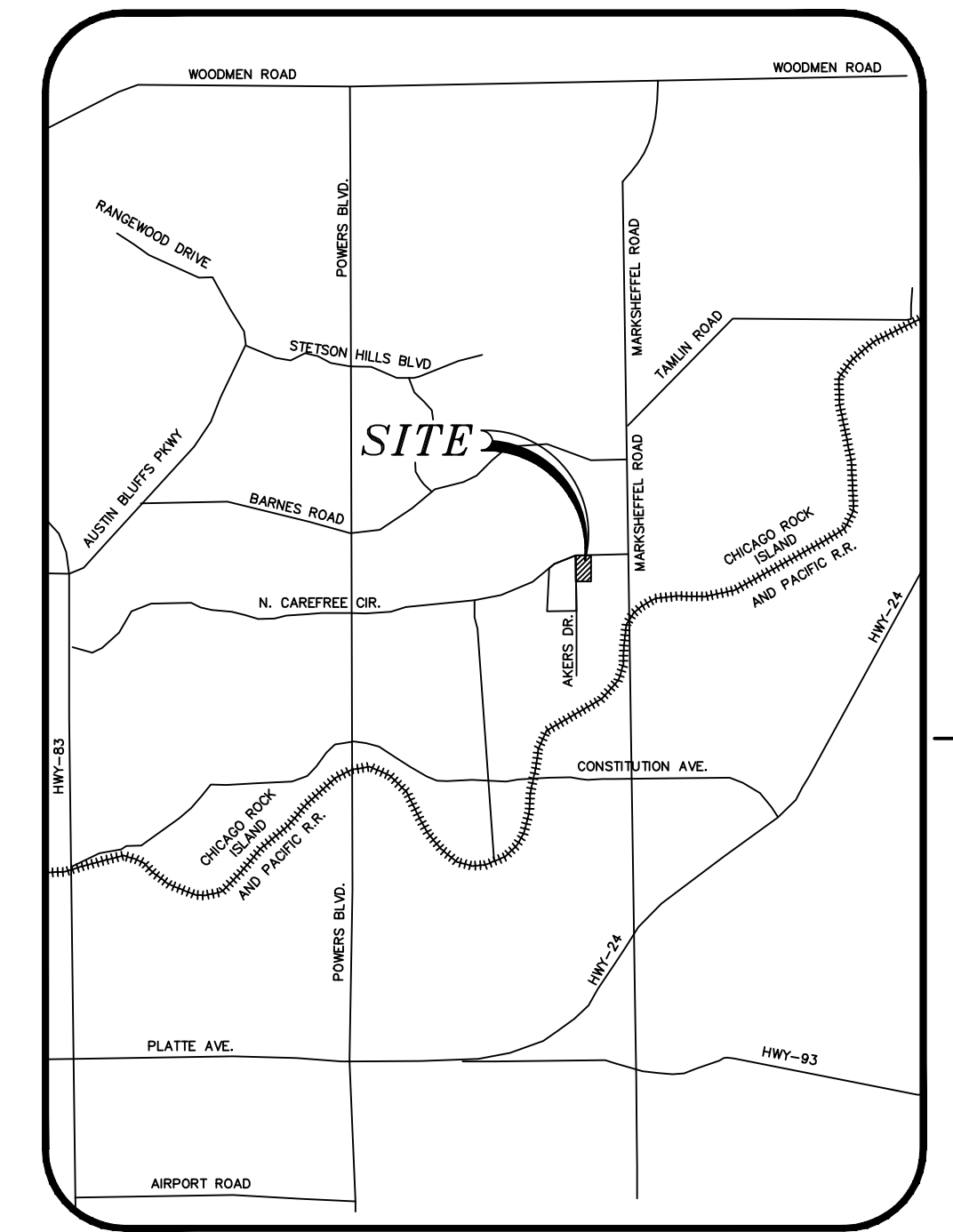

VICINITY MAP
N.T.S.

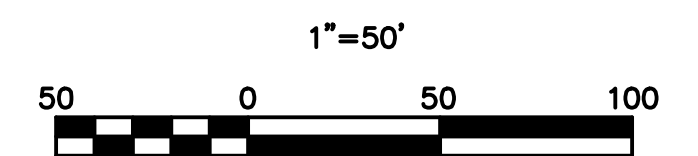
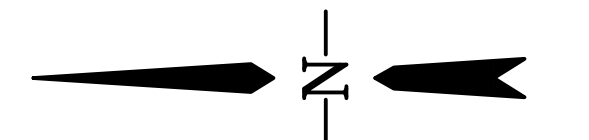
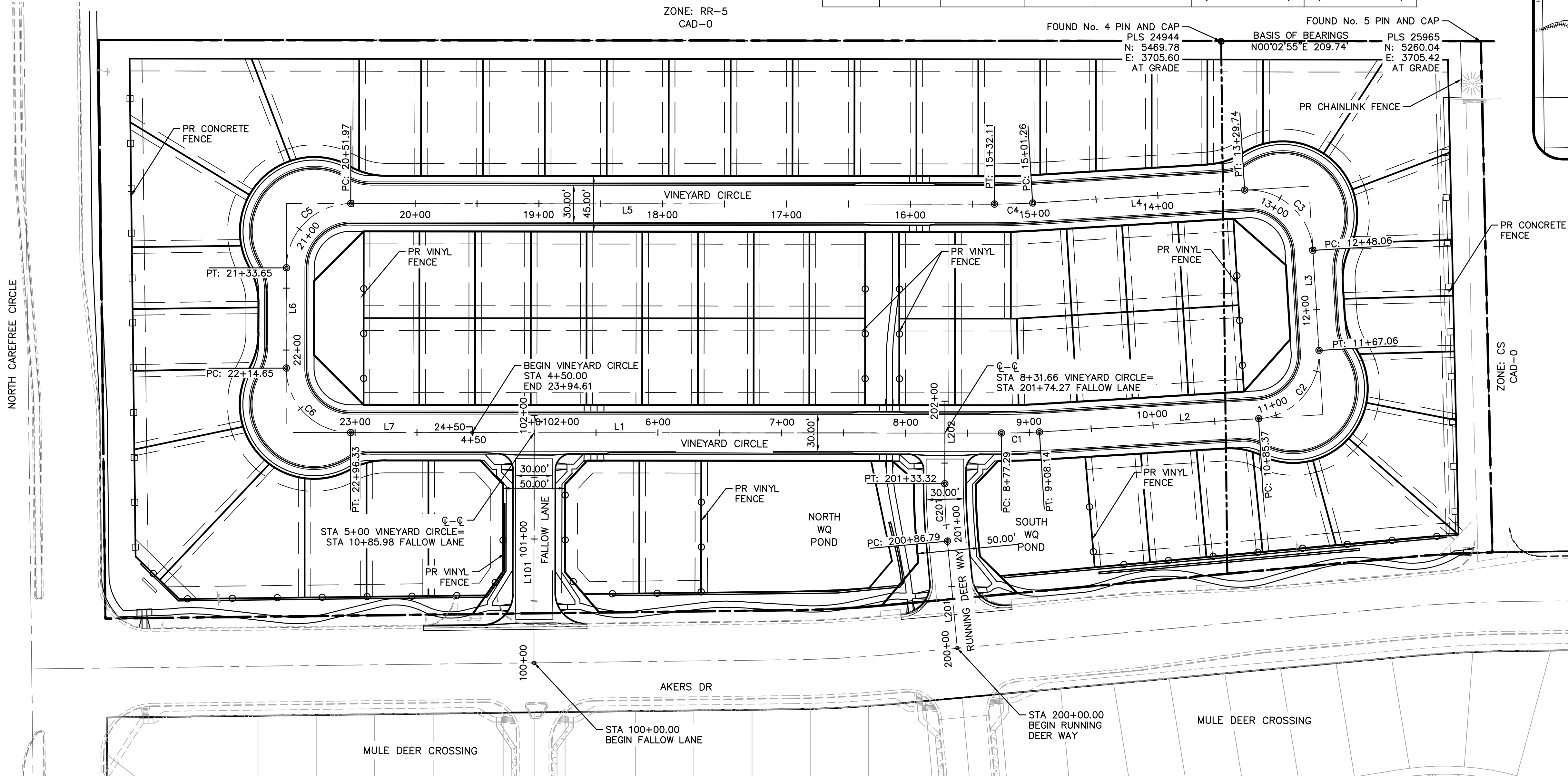

BASIS OF BEARINGS:

BEARINGS ARE BASED ON THE EAST LINE OF LOT 2, MULE DEER BUSINESS PARK FILING NO. 1, RECORDED AT RECEPTION NO. 206712353 IN THE RECORDS OF EL PASO COUNTY, SAID LINE BEARS N00°02'55"E FROM THE SOUTHEAST CORNER OF SAID LOT 2 (NO. 5 PIN AND CAP PLS 28955) TO THE NORTHEAST CORNER OF SAID LOT 2 (NO. 4 PIN AND CAP PLS 24964)

V:\52876\active\187608744\Mule Deer\CAD\Sheets\Construction Drawings\04 - Site Plan.dwg 2019/11/21 9:39 AM By: Pearce, Taylor

Computer File Information	
Creation Date: 4-25-17	Initials: CMD
Last Modification Date:	Initials:
Full Path & Drawing File Name:	
Acad Ver. 2014	Scale: Units: Feet

Index of Revisions	

Stantec Consulting Inc.
5725 MARK DABLING BLVD
Suite 190
Colorado Springs, CO 80919
Tel. (719) 594-4535
Fax.
www.stantec.com

GARDENS AT NORTH CAREFREE SITE PLAN	
Designer: CD	Structure Numbers
Detailer: MB	
Sheet Subst:	

Project No./Code
187608744
SHEET 4 OF 34

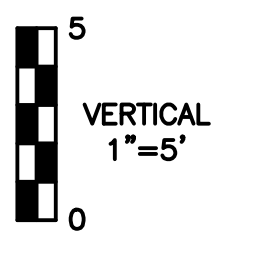
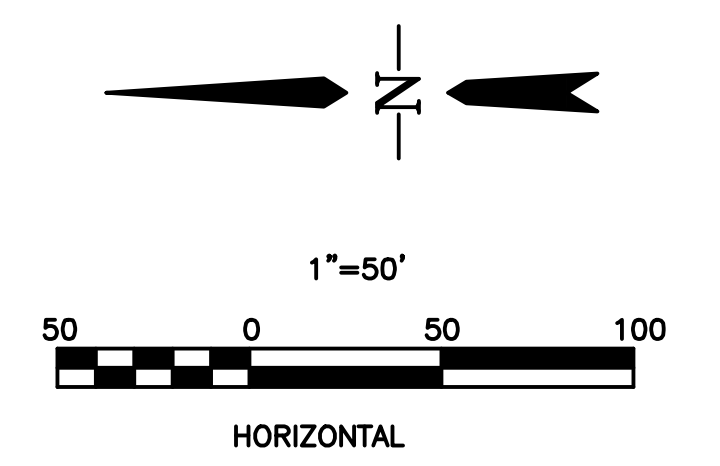

NOTES:

1. ALL SPOT ELEVATIONS ARE FLOW LINE UNLESS OTHERWISE NOTED.
2. SEE FINAL GRADING PLAN FOR GRADING INFORMATION.
3. ALL MANHOLES SHALL BE TYPE 1 UNLESS OTHERWISE NOTED.

- ① CURB TRANSITION, SEE SHEET 2
- ② PEDESTRIAN RAMP, SEE SHEET 2

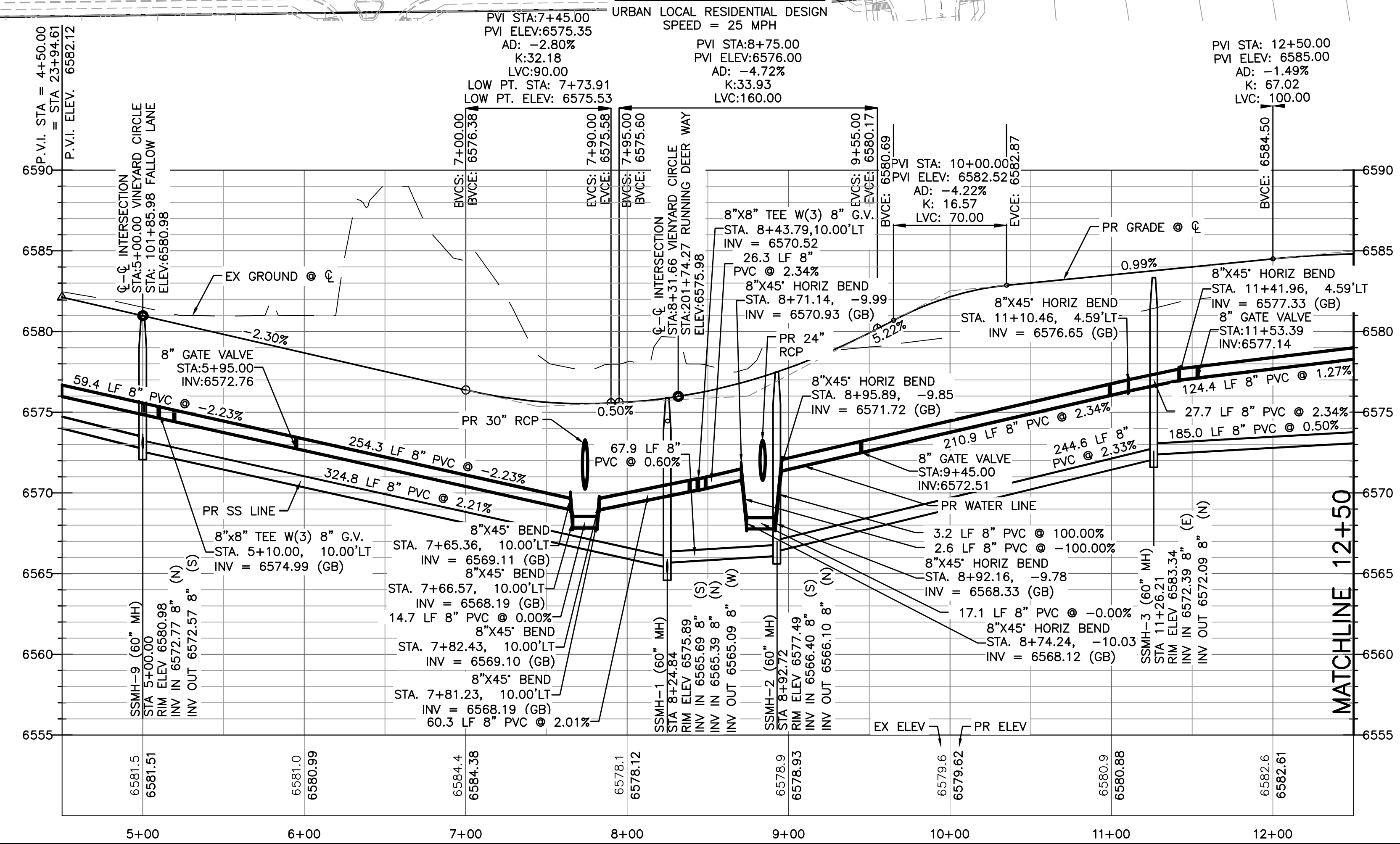
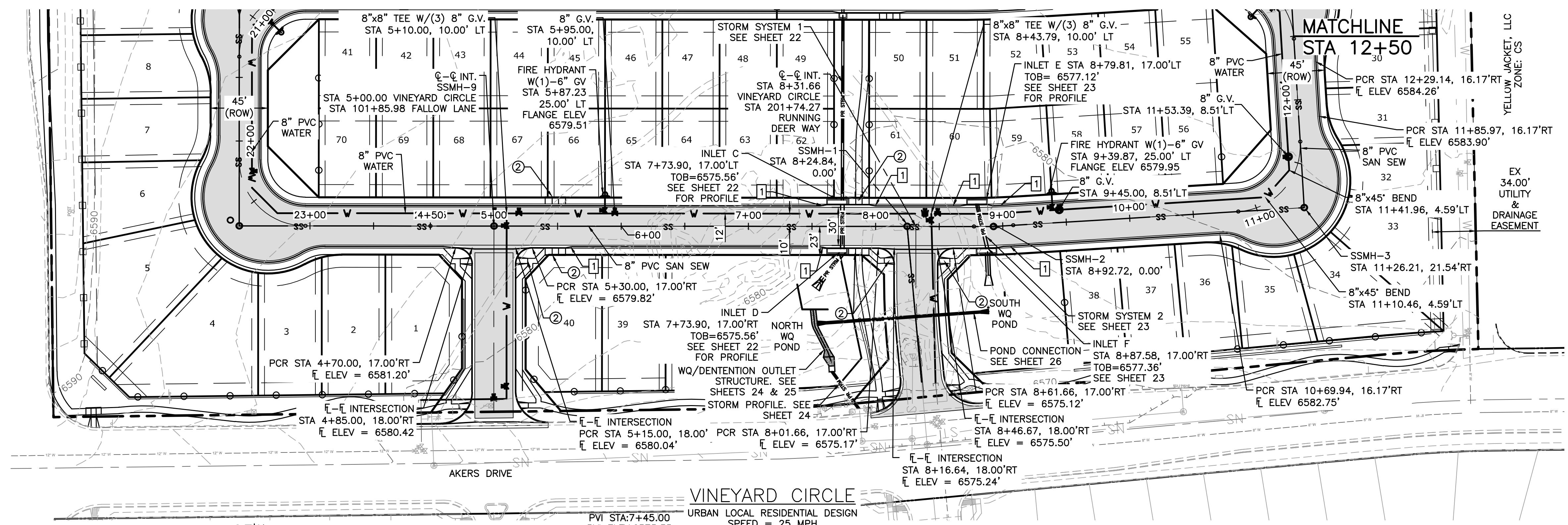

LEGEND

- EX MINOR CONTOUR
- EX MAJOR CONTOUR
- EX WATER
- EX SAN SEWER
- EX GAS
- EX STORM SEWER
- EX WATER VALVE
- EX FIRE HYDRANT
- EX SANITARY SEWER MH
- PR MINOR CONTOUR
- PR MAJOR CONTOUR
- PR ROW
- PR WATER LINE
- PR SANITARY SEWER
- PR STORM SEWER
- PR SANITARY SEWER MANHOLE
- PR TYPE R INLET
- PR WATER VALVE
- PR FIRE HYDRANT

V:\52876\active\187608744-Mule Deer\CAD\Sheets\Construction Drawings\05 - PnP 1.dwg
2019/12/19 11:05 AM By: Pearce, Taylor

Computer File Information	
Creation Date: 4-25-17	Initials: CMD
Last Modification Date:	Initials:
Full Path & Drawing File Name:	
Acad Ver. 2014	Scale: Units: Feet

Index of Revisions	



Stantec Consulting Inc.
5725 MARK DABLING BLVD
Suite 190
Colorado Springs, CO 80919
Tel. (719) 594-4535
Fax.
www.stantec.com

GARDENS AT NORTH CAREFREE PLAN AND PROFILE VINEYARD CIRCLE	
Designer: CD	Structure Numbers
Detailer: MB	
Sheet Subst:	

Project No./Code	
187608744	
SHEET 5 OF 34	

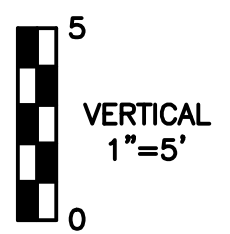
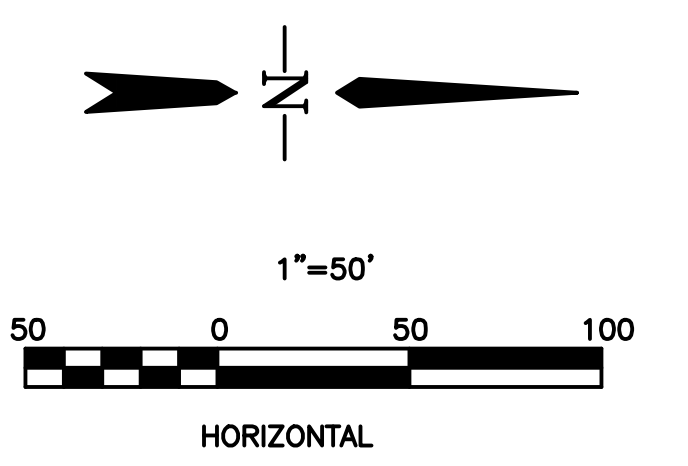
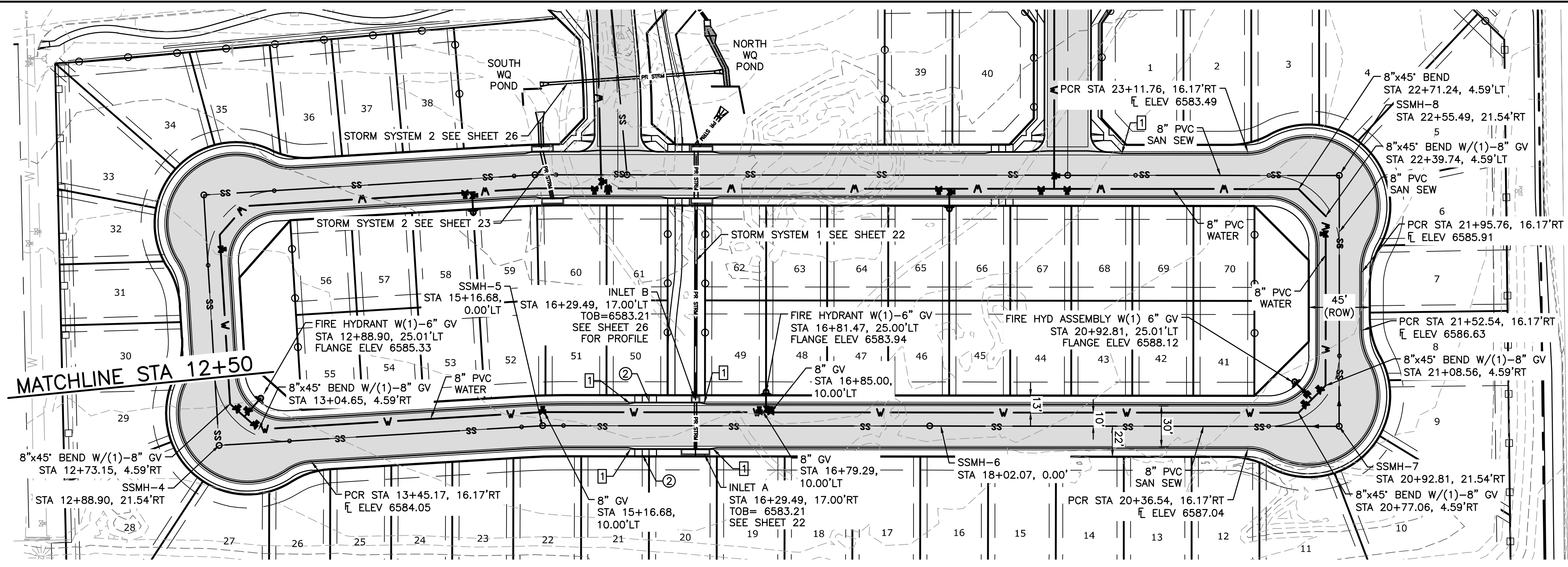

- NOTES:**
1. ALL SPOT ELEVATIONS ARE FLOW LINE UNLESS OTHERWISE NOTED.
 2. SEE FINAL GRADING PLAN FOR GRADING INFORMATION.
 3. ALL MANHOLES SHALL BE TYPE 1 UNLESS OTHERWISE NOTED.
- ① CURB TRANSITION, SEE SHEET 2
 ② PEDESTRIAN RAMP, SEE SHEET 2

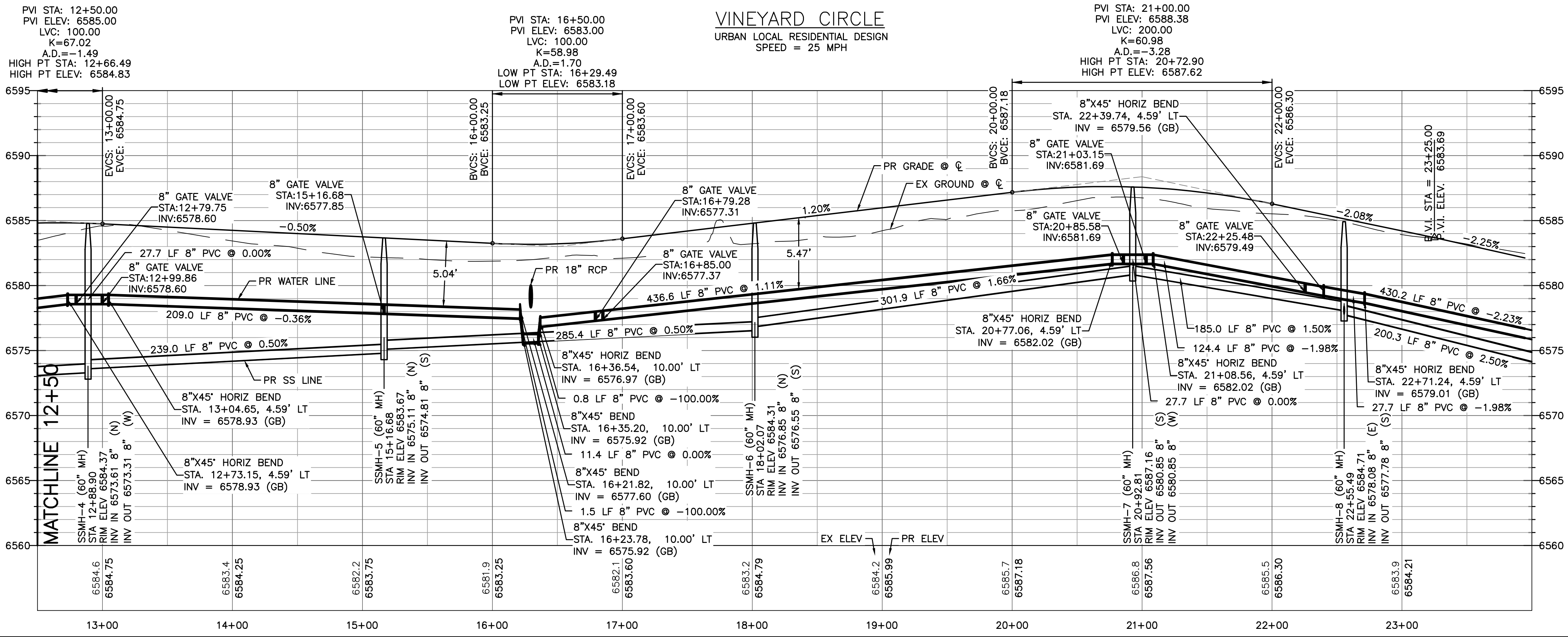

LEGEND

EX MINOR CONTOUR	---
EX MAJOR CONTOUR	---5200---
EX WATER	W
EX SAN SEWER	SN
EX GAS	G
EX STORM SEWER	SS
EX WATER VALVE	(Symbol)
EX FIRE HYDRANT	(Symbol)
EX SANITARY SEWER MH	(Symbol)
PR MINOR CONTOUR	---
PR MAJOR CONTOUR	---5200---
PR ROW	(Symbol)
PR WATER LINE	(Symbol)
PR SANITARY SEWER	(Symbol)
PR STORM SEWER	(Symbol)
PR SANITARY SEWER MANHOLE	(Symbol)
PR TYPE R INLET	(Symbol)
PR WATER VALVE	(Symbol)
PR FIRE HYDRANT	(Symbol)

V:\52876\active\187608744-Mule Deer\CAD\Sheets\Construction Drawings\06 - PnP 2.dwg
 2019/12/19 11:06 AM By: Pearce, Taylor

Computer File Information

Creation Date: 4-25-17	Initials: CMD
Last Modification Date:	Initials:
Full Path & Drawing File Name:	
Acad Ver. 2014	Scale: Units: Feet

Index of Revisions

Stantec
 Stantec Consulting Inc.
 5725 MARK DABLING BLVD
 Suite 190
 Colorado Springs, CO 80919
 Tel. (719) 594-4535
 Fax.
 www.stantec.com

**GARDENS AT NORTH CAREFREE
 PLAN AND PROFILE
 VINEYARD CIRCLE**

Designer: CD	Structure Numbers:
Detailer: MB	
Sheet Subst:	

Project No./Code
 187608744

SHEET 6 OF 34

V:\52876\active\187608744-Mule Deer\CAD\Sheets\Construction Drawings\07 -PnP 3.dwg
2019/12/19 11:09 AM By: Pearce, Taylor

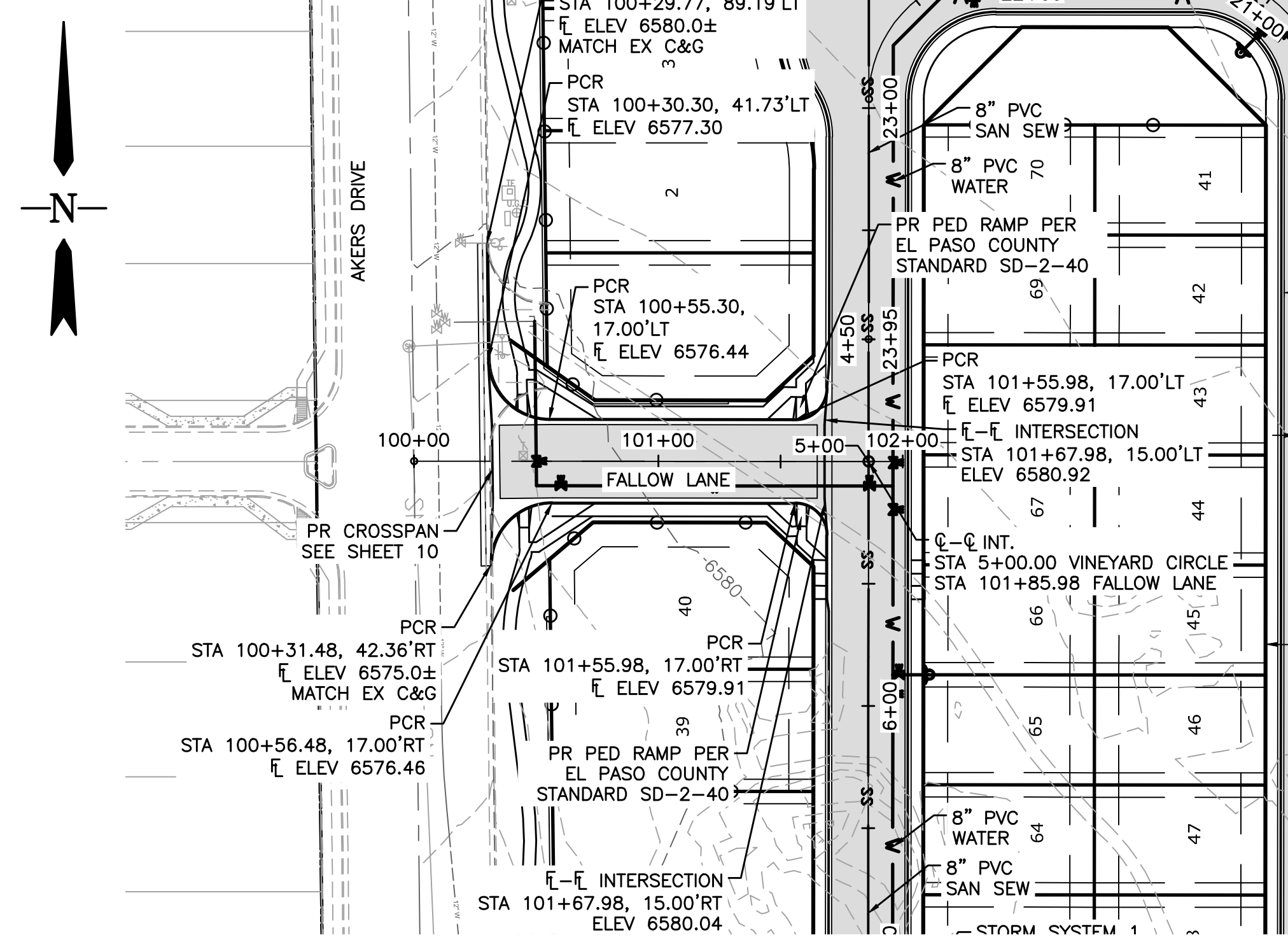

FALLOW LANE
URBAN LOCAL RESIDENTIAL
DESIGN SPEED = 25 MPH

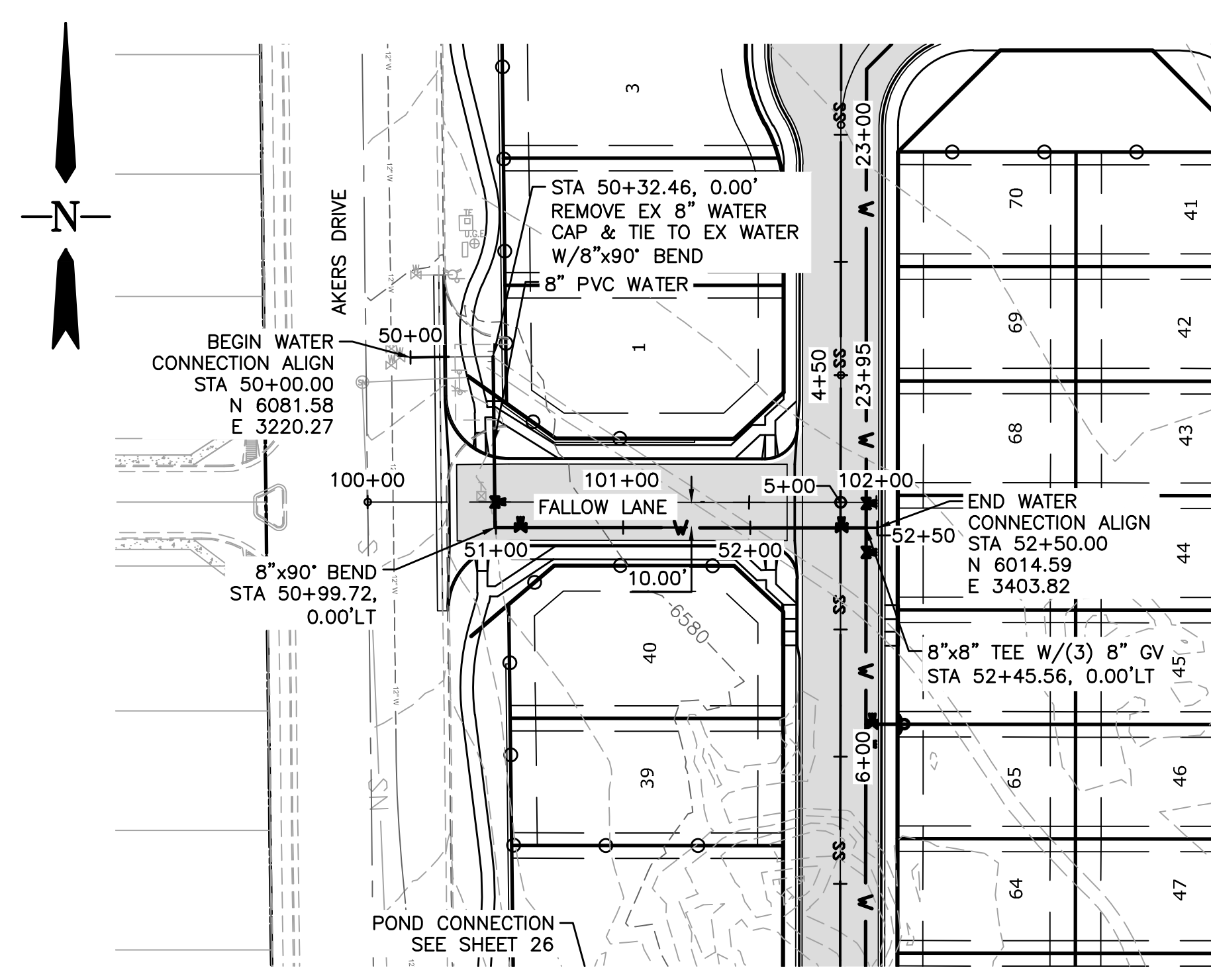

FALLOW LANE WATER CONNECTION

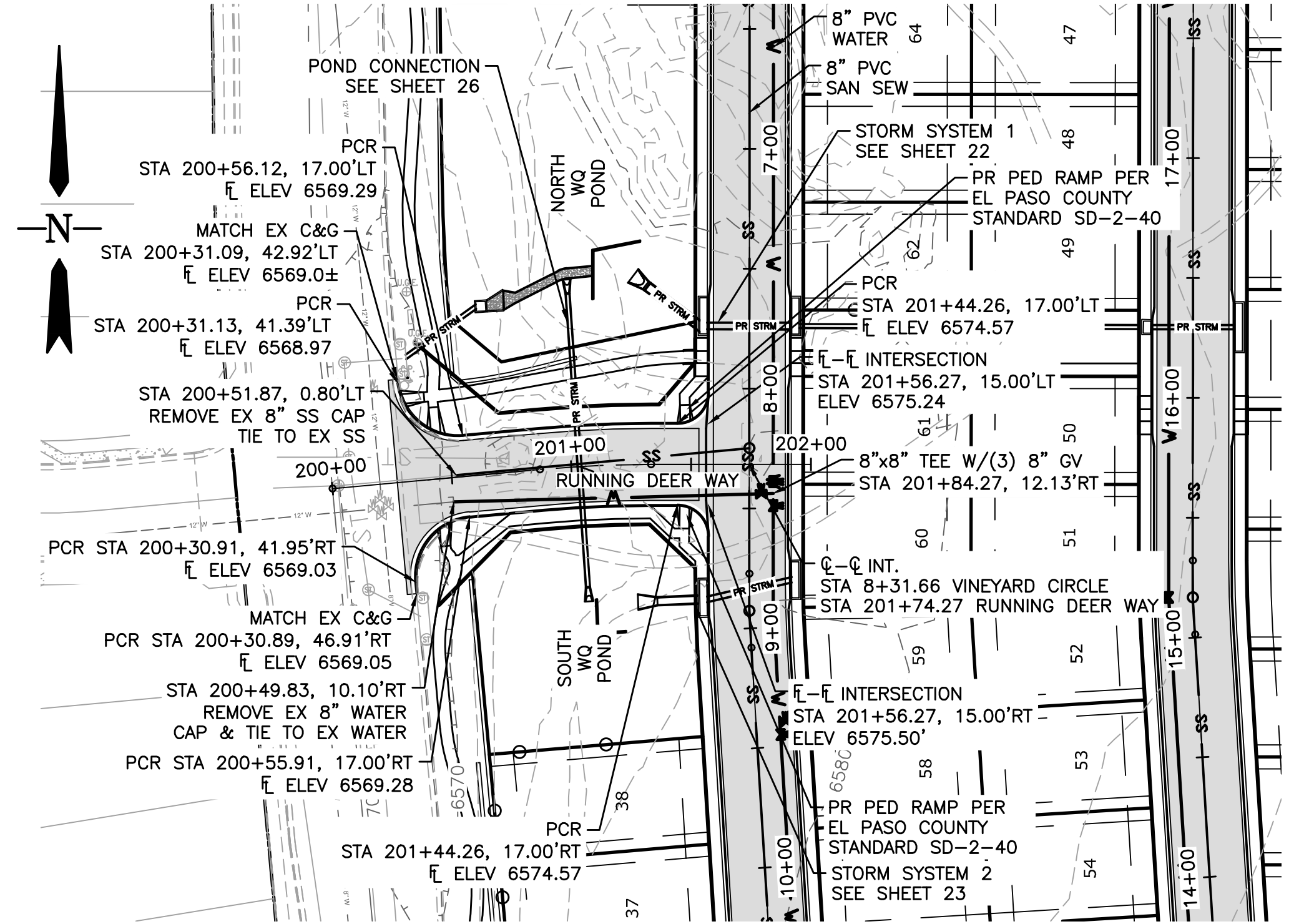

RUNNING DEER WAY
URBAN LOCAL RESIDENTIAL
DESIGN SPEED = 25 MPH

LEGEND

EX MINOR CONTOUR	---
EX MAJOR CONTOUR	--- 5200 ---
EX WATER	---
EX SAN SEWER	---
EX GAS	---
EX STORM SEWER	---
EX WATER VALVE	---
EX FIRE HYDRANT	---
EX SANITARY SEWER MH	---
PR MINOR CONTOUR	---
PR MAJOR CONTOUR	---
PR ROW	---
PR WATER LINE	---
PR SANITARY SEWER	---
PR STORM SEWER	---
PR SANITARY SEWER MANHOLE	---
PR TYPE R INLET	---
PR WATER VALVE	---
PR FIRE HYDRANT	---

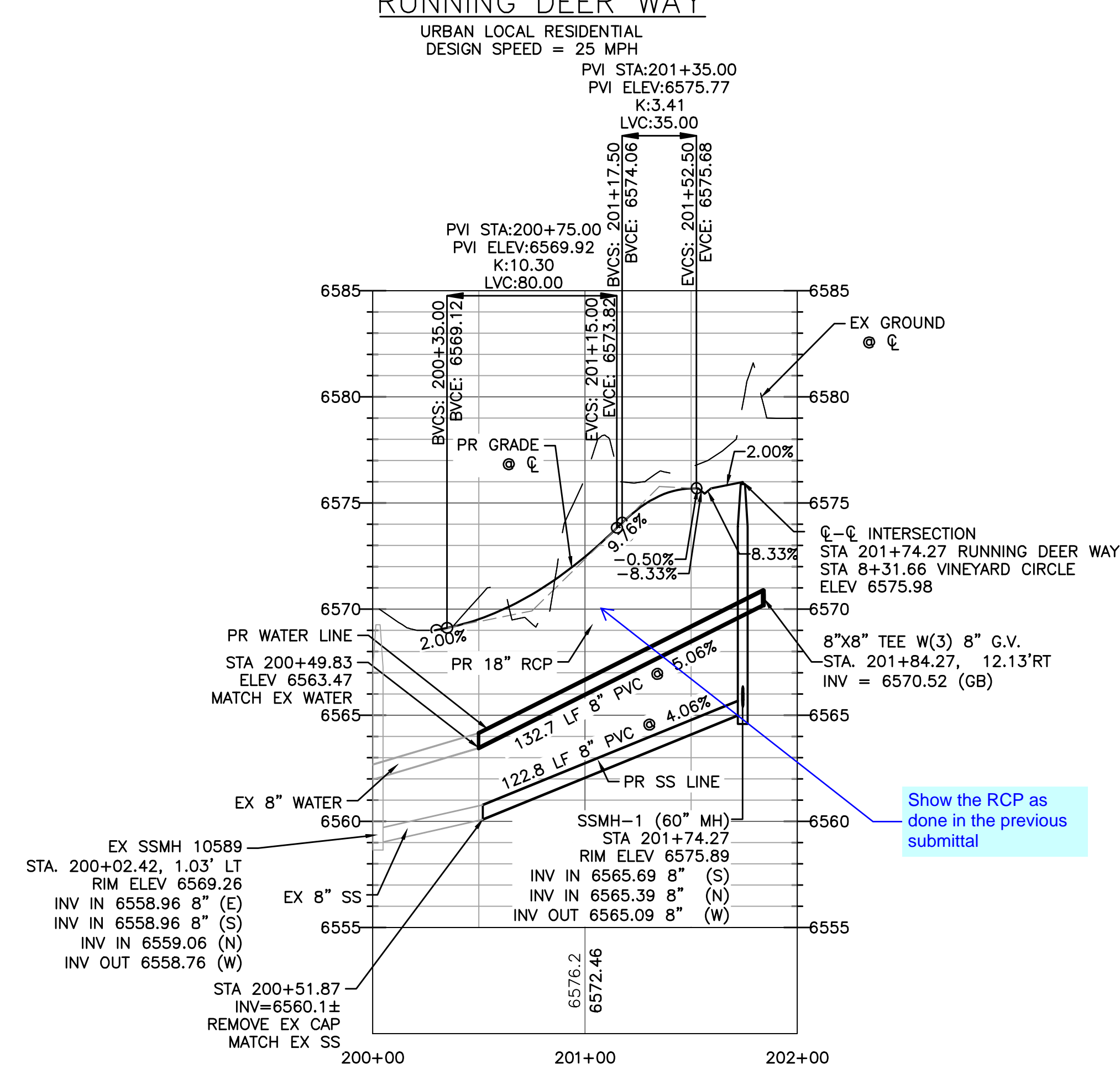
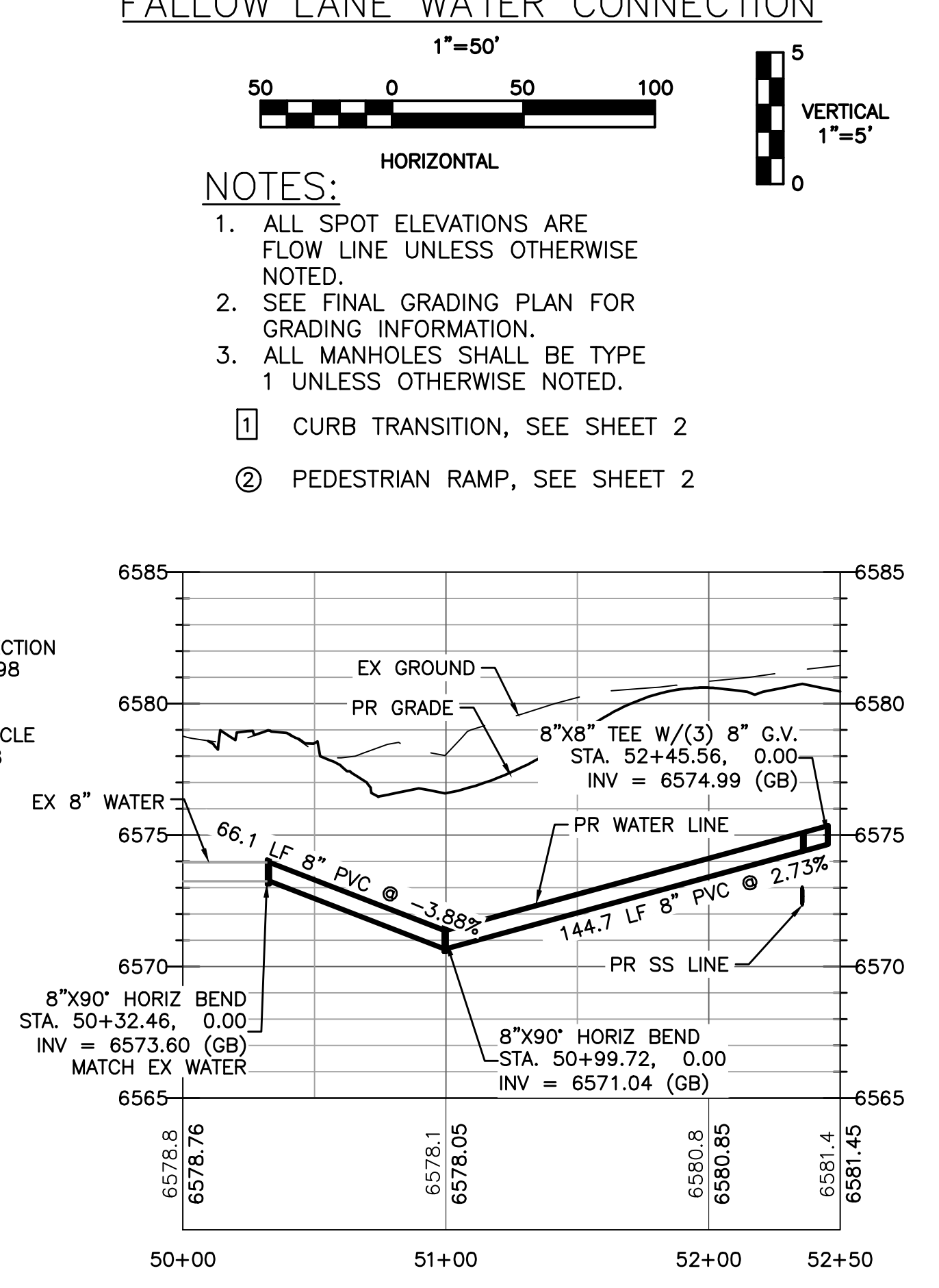
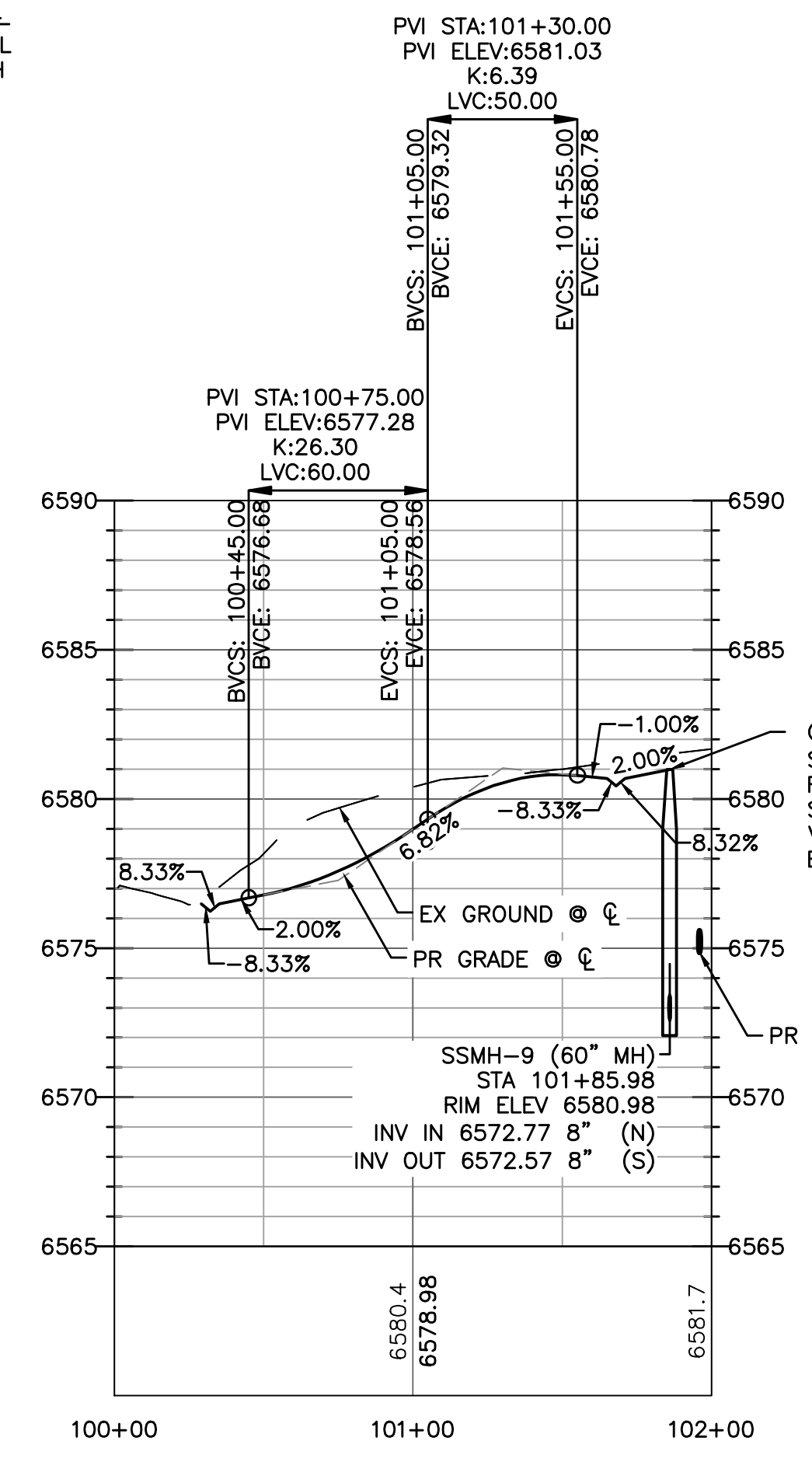

- NOTES:**
- ALL SPOT ELEVATIONS ARE FLOW LINE UNLESS OTHERWISE NOTED.
 - SEE FINAL GRADING PLAN FOR GRADING INFORMATION.
 - ALL MANHOLES SHALL BE TYPE 1 UNLESS OTHERWISE NOTED.
- ① CURB TRANSITION, SEE SHEET 2
② PEDESTRIAN RAMP, SEE SHEET 2



Computer File Information

Creation Date: 4-25-17	Initials: CMD
Last Modification Date:	Initials:
Full Path & Drawing File Name:	
Acad Ver. 2014	Scale: Units: Feet

Index of Revisions

Stantec
Stantec Consulting Inc.
5725 MARK DABLING BLVD
Suite 190
Colorado Springs, CO 80919
Tel. (719) 594-4535
Fax:
www.stantec.com

**GARDENS AT NORTH CAREFREE
PLAN AND PROFILE
FALLOW LANE & RUNNING DEER WAY**

Designer: CD	Structure Numbers	Project No./Code 187608744
Detailer: MB		
Sheet Subst:		SHEET 7 OF 34

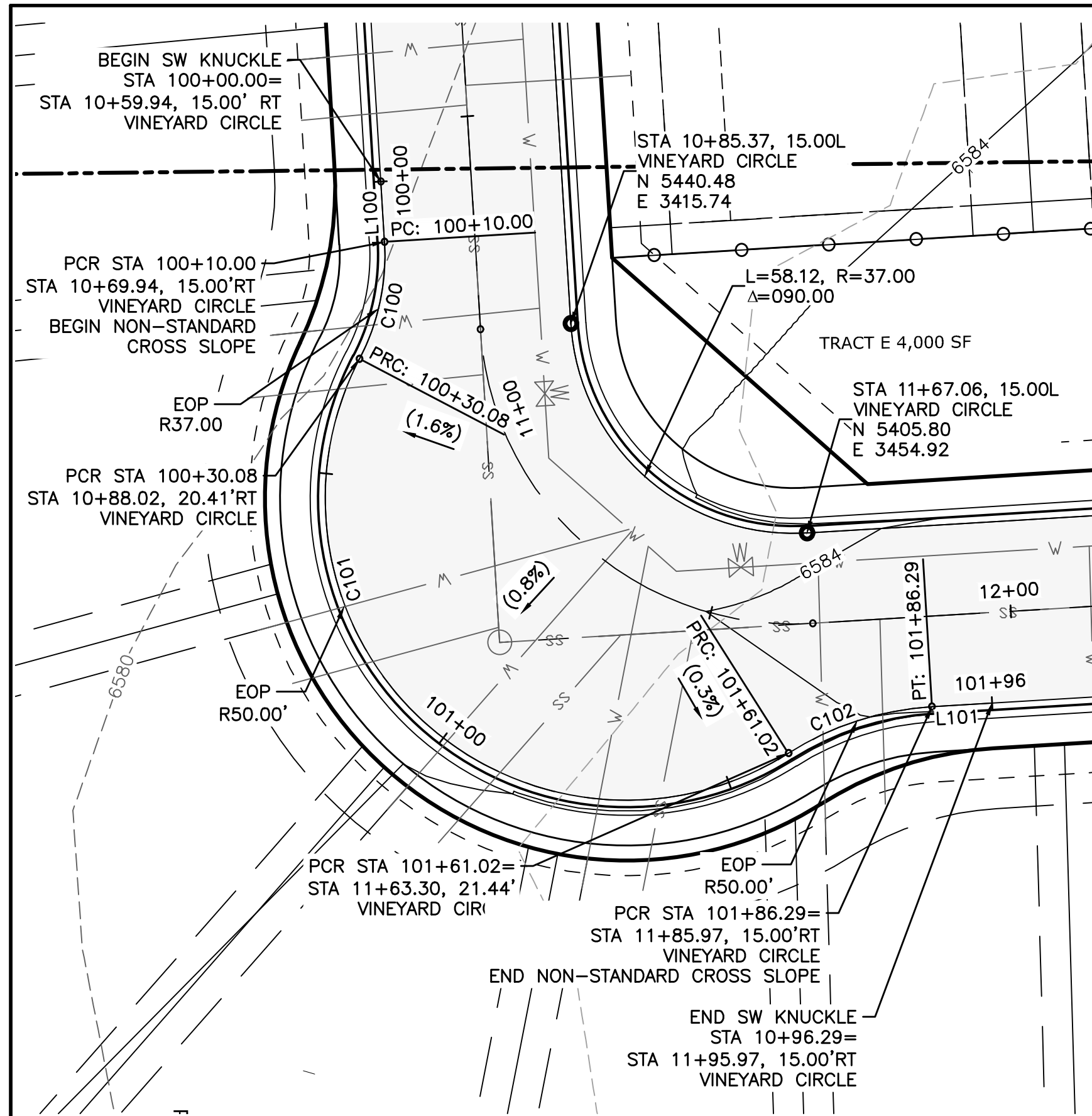

CURVE TABLE: ALIGNMENTS

CURVE #	START STA	END STA	RADIUS	LENGTH	CHORD DIRECTION	DELTA	START POINT (EAST, NORTH)	END POINT (EAST, NORTH)
C100	100+10.00	100+30.08	37.00	20.08	S12° 03' 43.39"W	31.09	(3384.86,5454.06)	(3380.71,5434.67)
C101	100+30.08	101+61.02	50.00	130.94	S47° 24' 55.66"E	150.05	(3380.71,5434.67)	(3451.84,5369.30)
C102	101+61.02	101+86.29	50.00	25.27	N72° 02' 15.28"E	28.96	(3451.84,5369.30)	(3475.62,5377.01)
C200	200+10.00	200+35.27	50.00	25.27	S79° 00' 26.64"E	28.96	(3518.72,5379.63)	(3543.26,5374.86)
C201	200+35.27	201+66.21	50.00	130.94	N40° 26' 44.30"E	150.05	(3543.26,5374.86)	(3605.93,5448.38)
C202	201+66.21	201+86.29	37.00	20.08	N19° 01' 54.75"W	31.09	(3605.93,5448.38)	(3599.46,5467.13)

LINE TABLE: ALIGNMENTS

LINE #	LENGTH	START STA	END STA	DIRECTION	START POINT (EAST, NORTH)	END POINT (EAST, NORTH)
L100	10.00	100+00.00	100+10.00	S3° 29' 05.68"E	(3384.25,5464.04)	(3384.86,5454.06)
L101	10.00	101+86.29	101+96.29	N86° 30' 54.32"E	(3475.62,5377.01)	(3485.60,5377.61)
L200	10.00	200+00.00	200+10.00	N86° 30' 54.32"E	(3508.73,5379.02)	(3518.72,5379.63)
L201	10.00	201+86.29	201+96.29	N3° 29' 05.68"W	(3599.46,5467.13)	(3598.85,5477.11)

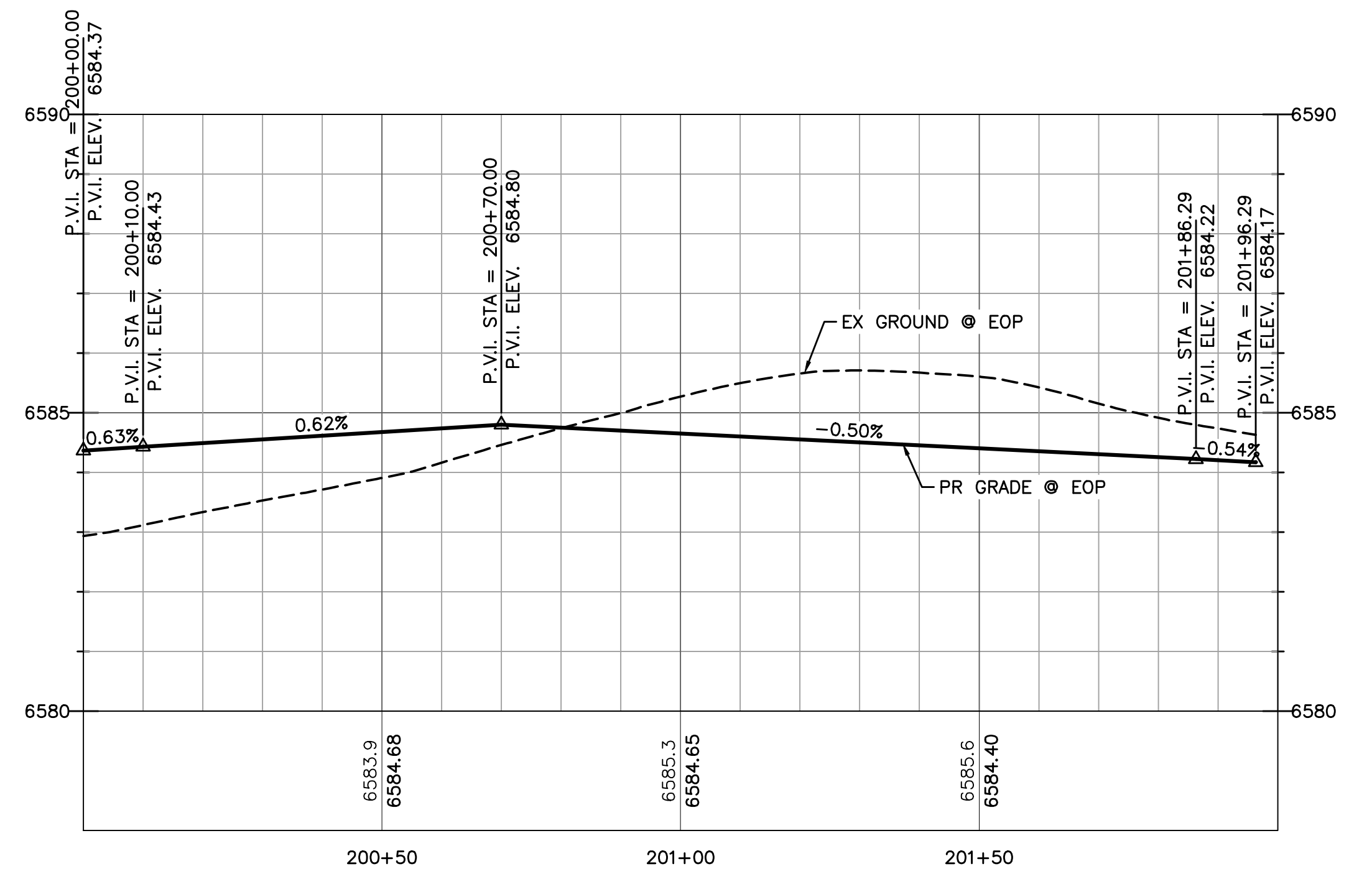
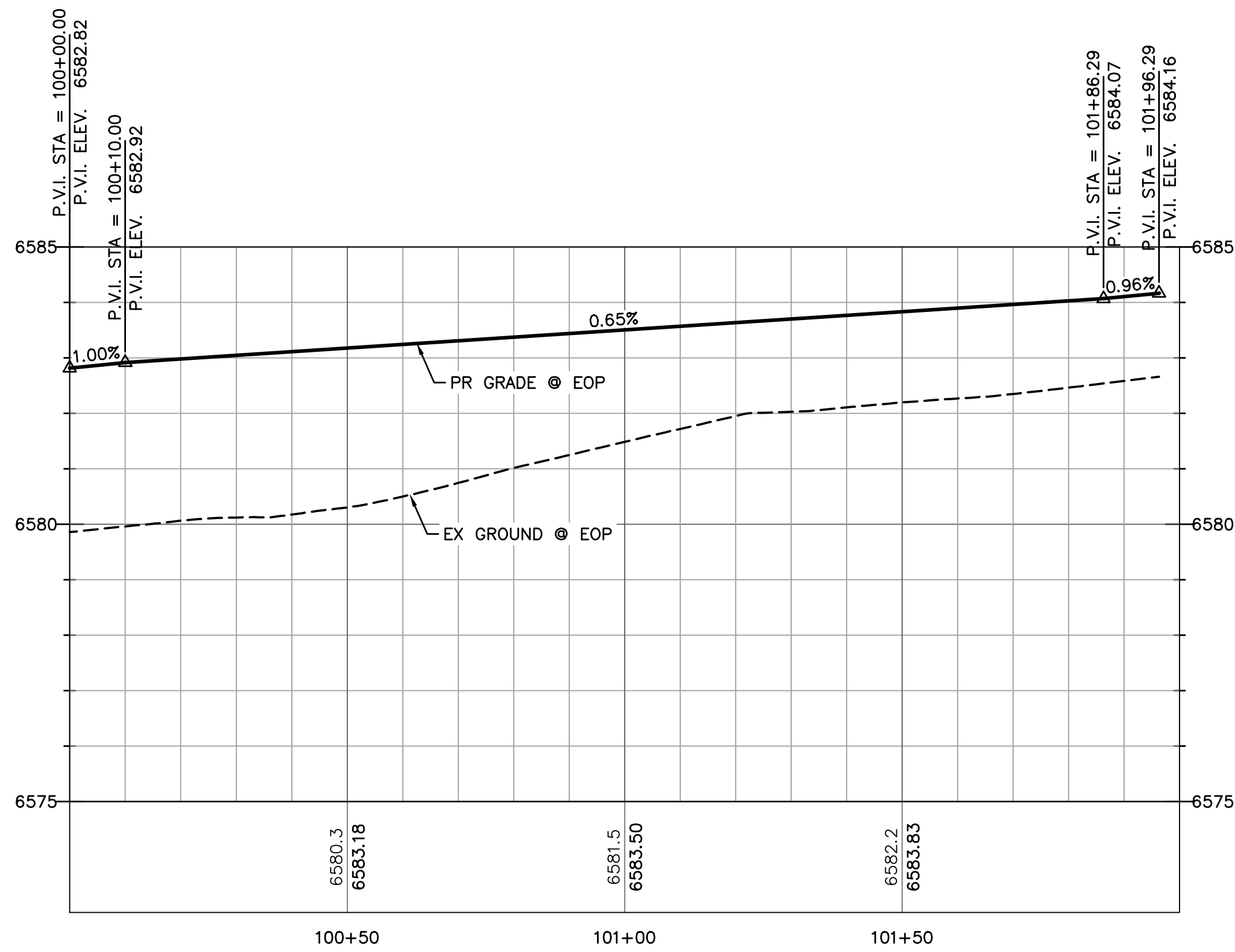
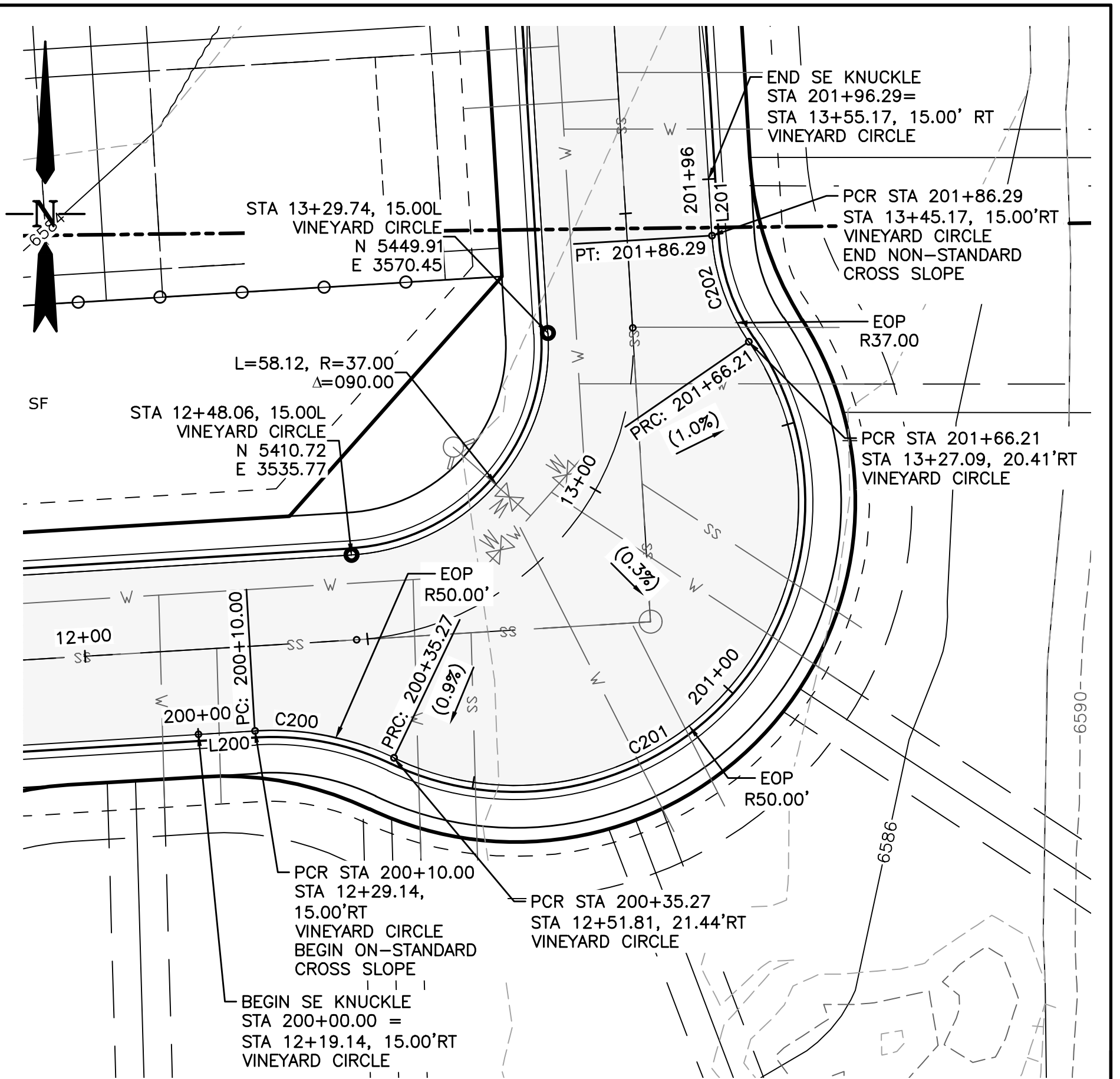
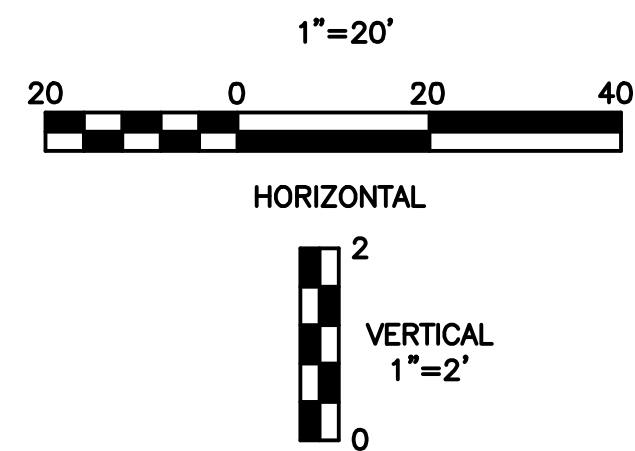

SW KNUCKLE CURB EOP

SE KNUCKLE CURB EOP

Computer File Information

Creation Date: 4-25-17	Initials: CMD
Last Modification Date:	Initials:
Full Path & Drawing File Name:	
Acad Ver. 2014	Scale: Units: Feet

Index of Revisions

0000			
0000			
0000			
0000			

Stantec Consulting Inc.
5725 MARK DABLING BLVD
Suite 190
Colorado Springs, CO 80919
Tel. (719) 594-4535
Fax.
www.stantec.com

**GARDENS AT NORTH CAREFREE
PLAN AND PROFILE
KNUCKLES**

Designer: CD	Structure Numbers
Detailer: MB	
Sheet Subset:	

Project No./Code
187608744

V:\52876\active\187608744-Mule Deer\CAD\Sheets\Construction Drawings\08 - PnP Knuckles.dwg 2019/11/21 11:04 AM By: Pearce, Taylor

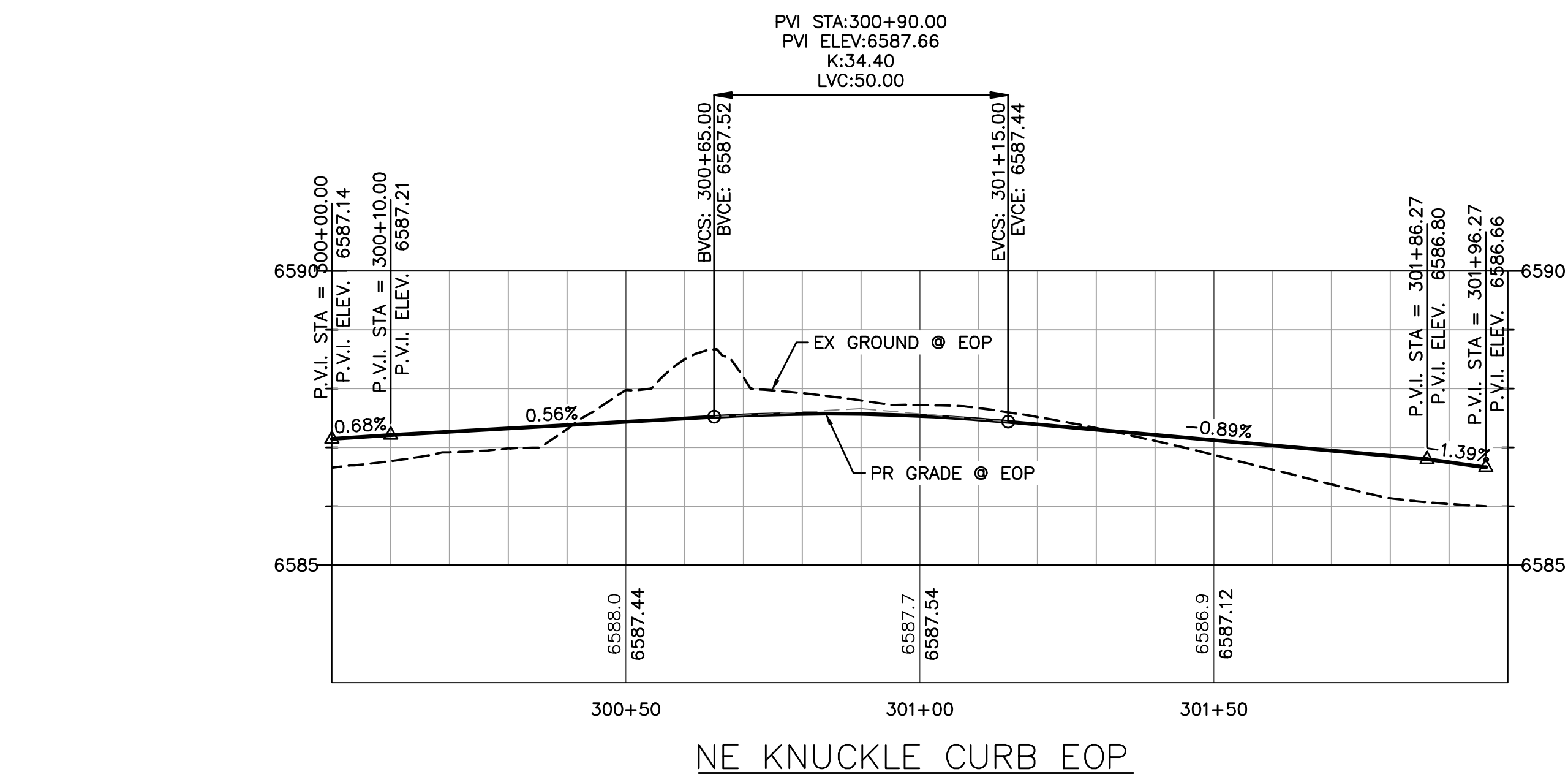
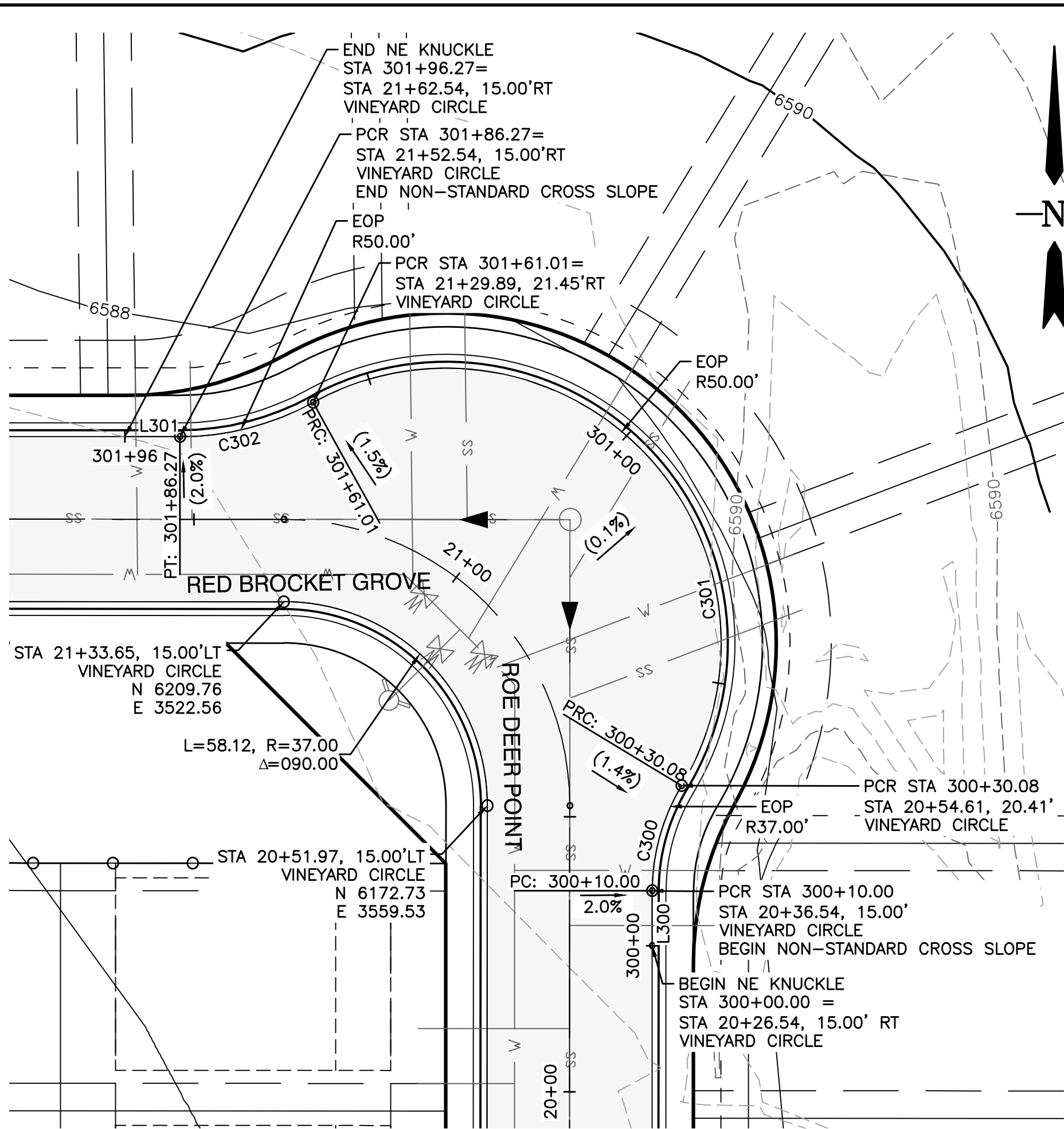

NE KNUCKLE CURB EOP

CURVE TABLE: ALIGNMENTS

CURVE #	START STA	END STA	RADIUS	LENGTH	CHORD DIRECTION	DELTA	START POINT (EAST, NORTH)	END POINT (EAST, NORTH)
C300	300+10.00	300+30.08	37.00	20.08	N15° 35' 48.65"E	31.09	(3589.51,6157.27)	(3594.85,6176.37)
C301	300+30.08	301+61.01	50.00	130.93	N43° 52' 27.50"W	150.04	(3594.85,6176.37)	(3527.89,6246.01)
C302	301+61.01	301+86.27	50.00	25.26	S75° 34' 43.44"W	28.94	(3527.89,6246.01)	(3503.69,6239.78)
C400	400+10.00	400+35.26	50.00	25.26	N75° 28' 44.27"W	28.94	(3460.48,6239.82)	(3436.29,6246.09)
C401	400+35.26	401+66.19	50.00	130.93	S43° 58' 26.66"W	150.04	(3436.29,6246.09)	(3369.21,6176.57)
C402	401+66.19	401+86.27	37.00	20.08	S15° 29' 49.48"E	31.09	(3369.21,6176.57)	(3374.51,6157.46)

LINE TABLE: ALIGNMENTS

LINE #	LENGTH	START STA	END STA	DIRECTION	START POINT (EAST, NORTH)	END POINT (EAST, NORTH)
L300	10.00	300+00.00	300+10.00	N0° 02' 59.58"E	(3589.50,6147.27)	(3589.51,6157.27)
L301	10.00	301+86.27	301+96.27	N89° 57' 00.42"W	(3503.69,6239.78)	(3493.69,6239.79)
L400	10.00	400+00.00	400+10.00	N89° 57' 00.42"W	(3470.48,6239.81)	(3460.48,6239.82)
L401	10.00	401+86.27	401+96.27	S0° 02' 59.58"W	(3374.51,6157.46)	(3374.50,6147.46)

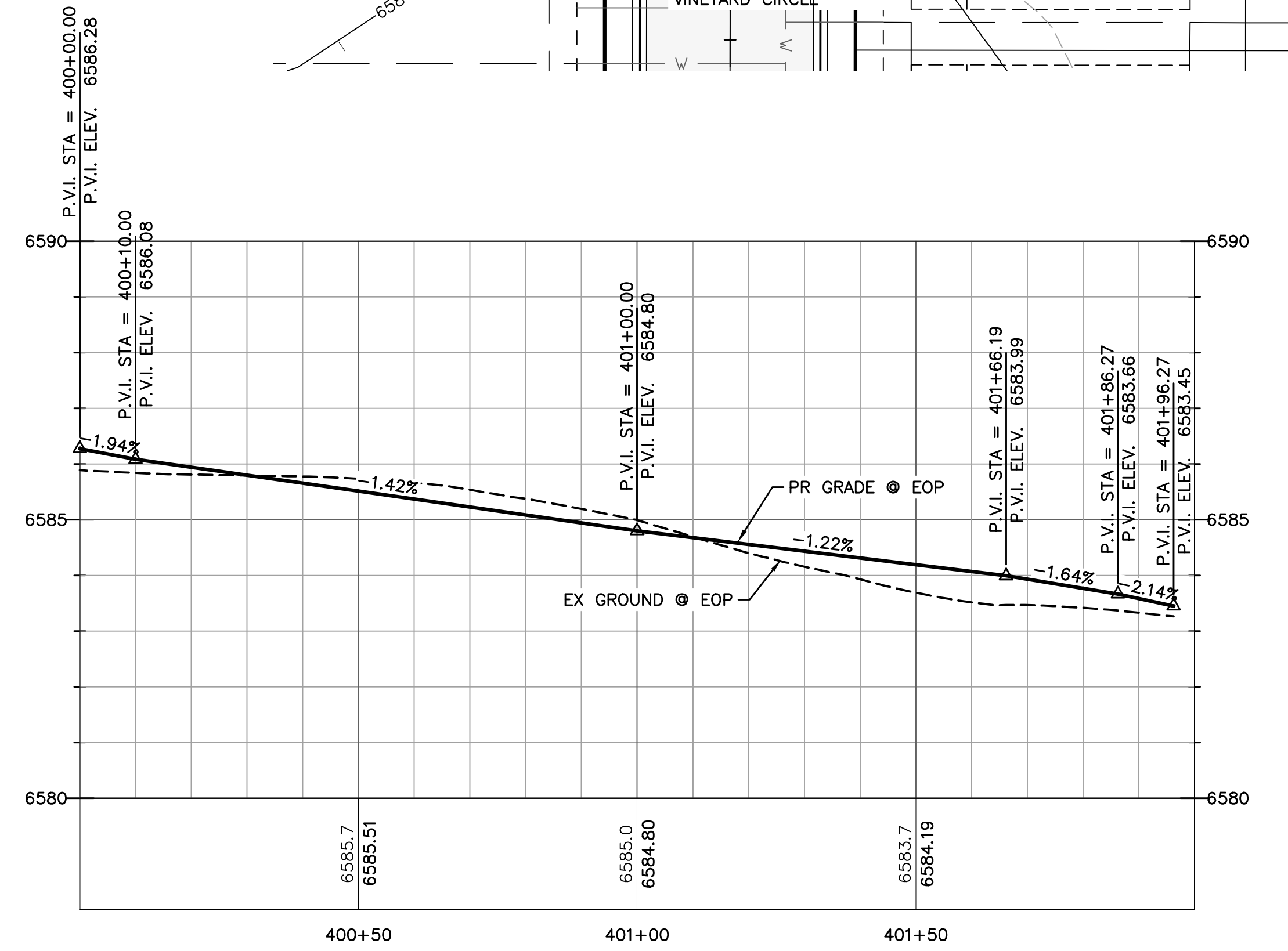
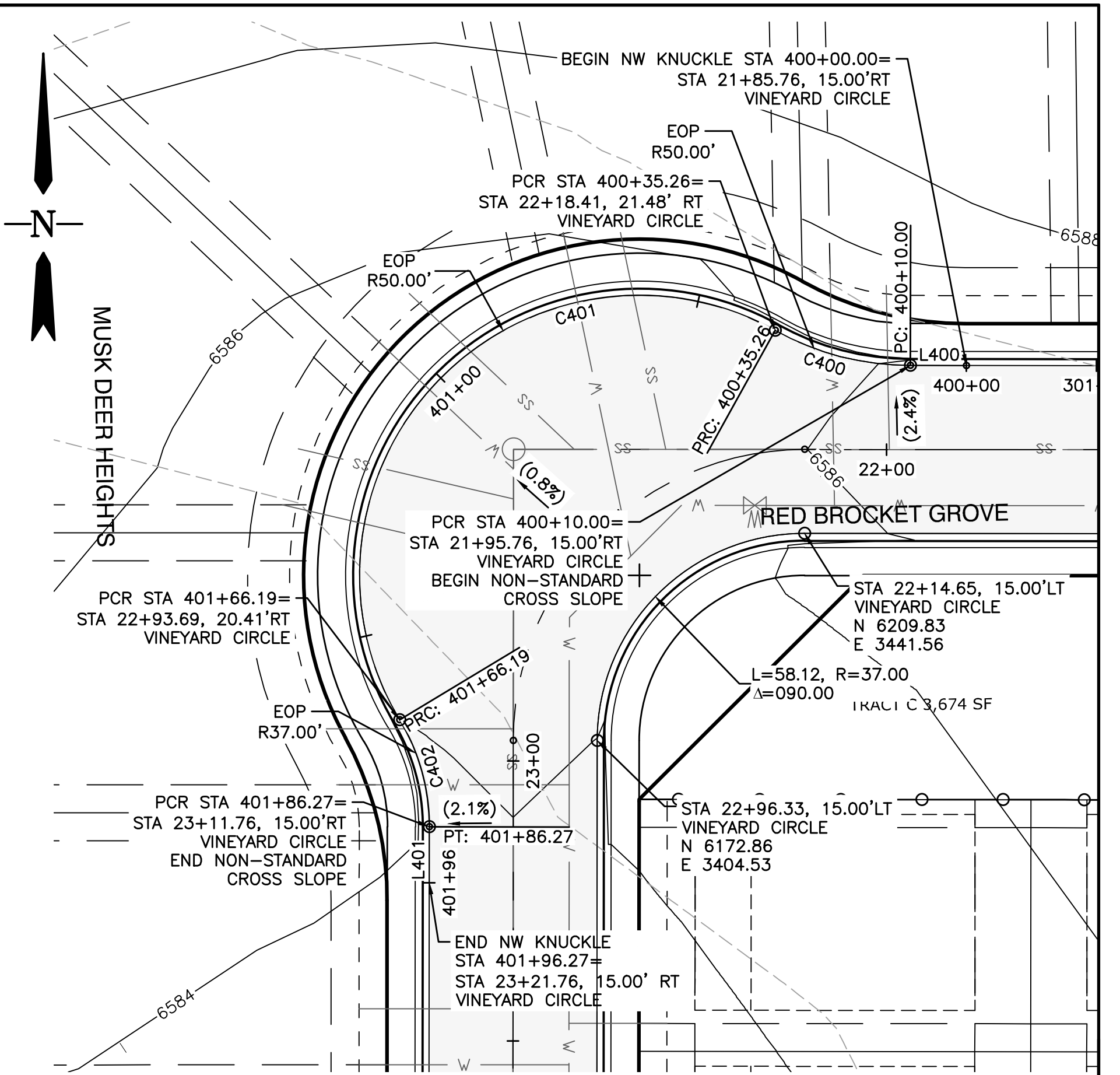
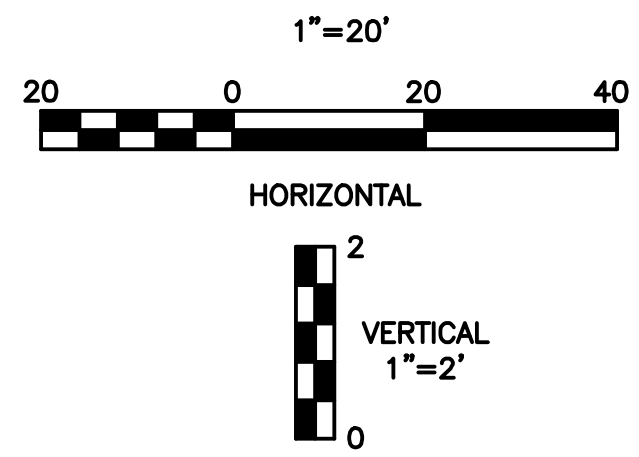

NW KNUCKLE CURB EOP

V:\52876\active\187608744-Mule Deer\CAD\Sheets\Construction Drawings\08 - PnP Knuckles.dwg
2019/11/21 11:02 AM By: Pearce, Taylor

Computer File Information	
Creation Date: 4-25-17	Initials: CMD
Last Modification Date:	Initials:
Full Path & Drawing File Name:	
Acad Ver. 2014	Scale: Units: Feet

Index of Revisions	
0000	

Stantec Consulting Inc.
5725 MARK DABLING BLVD
Suite 190
Colorado Springs, CO 80919
Tel. (719) 594-4535
Fax.
www.stantec.com

GARDENS AT NORTH CAREFREE PLAN AND PROFILE KNUCKLES	
Designer: CD	Structure Numbers
Detailer: MB	
Sheet Subset:	

Project No./Code
187608744
SHEET 9 OF 34

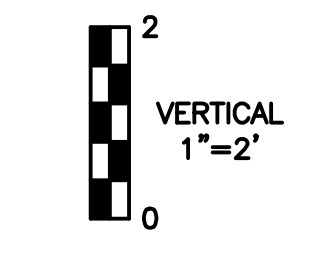
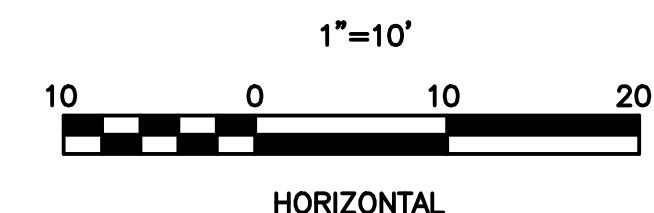
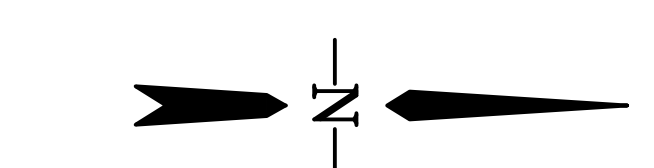
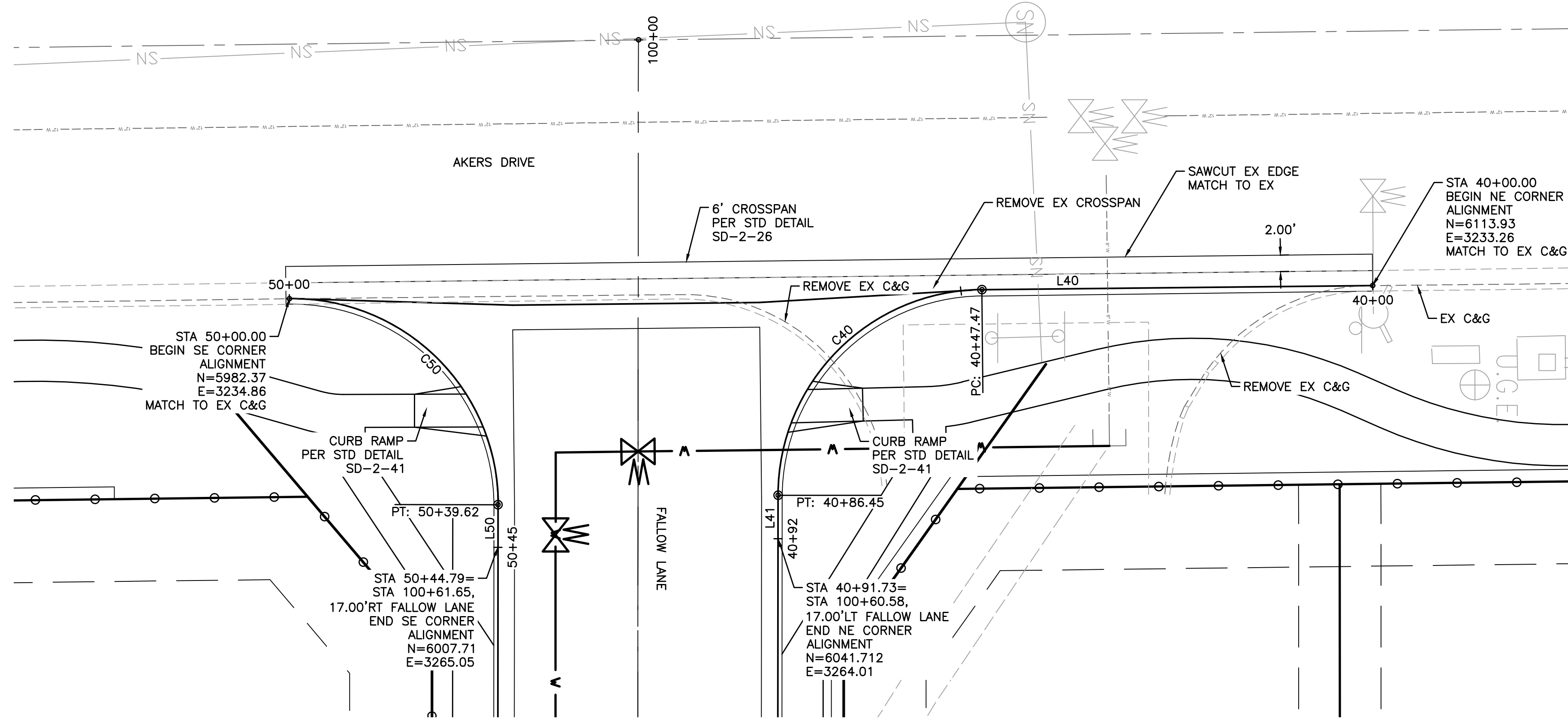

LEGEND

EX MINOR CONTOUR	---
EX MAJOR CONTOUR	-----
EX WATER	W
EX SAN SEWER	SN
EX GAS	G
EX STORM SEWER	SN
EX WATER VALVE	WV
EX FIRE HYDRANT	FH
EX SANITARY SEWER MH	SMH
PR MINOR CONTOUR	---
PR MAJOR CONTOUR	-----
PR ROW	---
PR WATER LINE	W
PR SANITARY SEWER	SS
PR STORM SEWER	PR STORM
PR SANITARY SEWER MANHOLE	SMH
PR TYPE R INLET	TRI
PR WATER VALVE	WV
PR FIRE HYDRANT	FH

CURVE TABLE: ALIGNMENTS

CURVE #	START STA	END STA	RADIUS	LENGTH	CHORD DIRECTION	DELTA	START POINT (EAST, NORTH)	END POINT (EAST, NORTH)
C40	40+47.47	40+86.45	25.00	38.99	S45° 16' 28.98"E	89.35	(3233.76,6066.46)	(3258.73,6041.72)
C50	50+00.00	50+39.62	25.00	39.62	N44° 38' 54.19"E	90.80	(3234.86,5982.37)	(3259.88,6007.70)

LINE TABLE: ALIGNMENTS

LINE #	LENGTH	START STA	END STA	DIRECTION	START POINT (EAST, NORTH)	END POINT (EAST, NORTH)
L40	47.47	40+00.00	40+47.47	S0° 35' 57.54"E	(3233.26,6113.93)	(3233.76,6066.46)
L41	5.28	40+86.45	40+91.73	S89° 57' 00.42"E	(3258.73,6041.72)	(3264.01,6041.72)
L50	5.17	50+39.62	50+44.79	S89° 57' 00.42"E	(3259.88,6007.70)	(3265.05,6007.70)

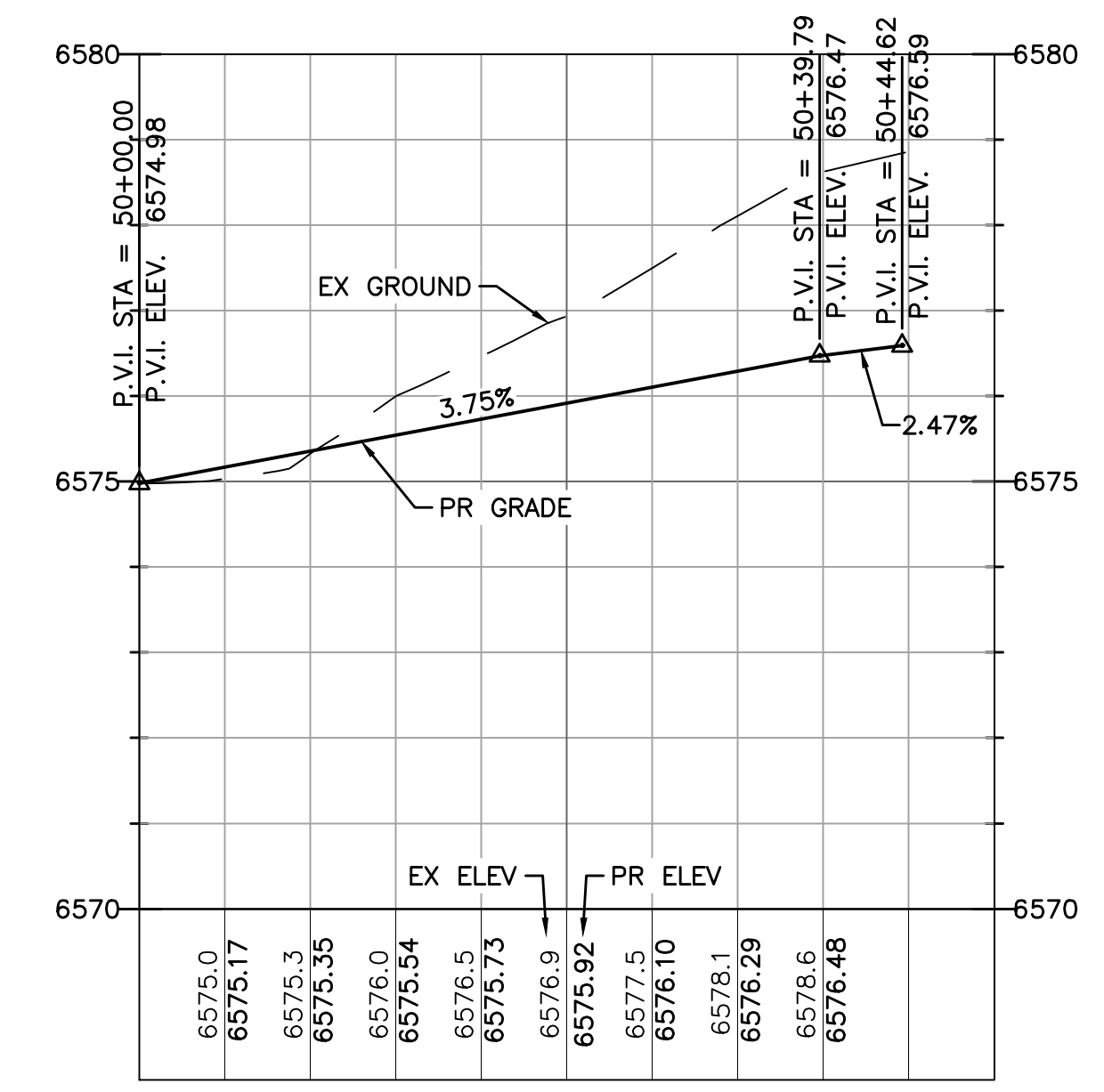

PROFILE FALLOW - SE CORNER CURB FLOWLINE

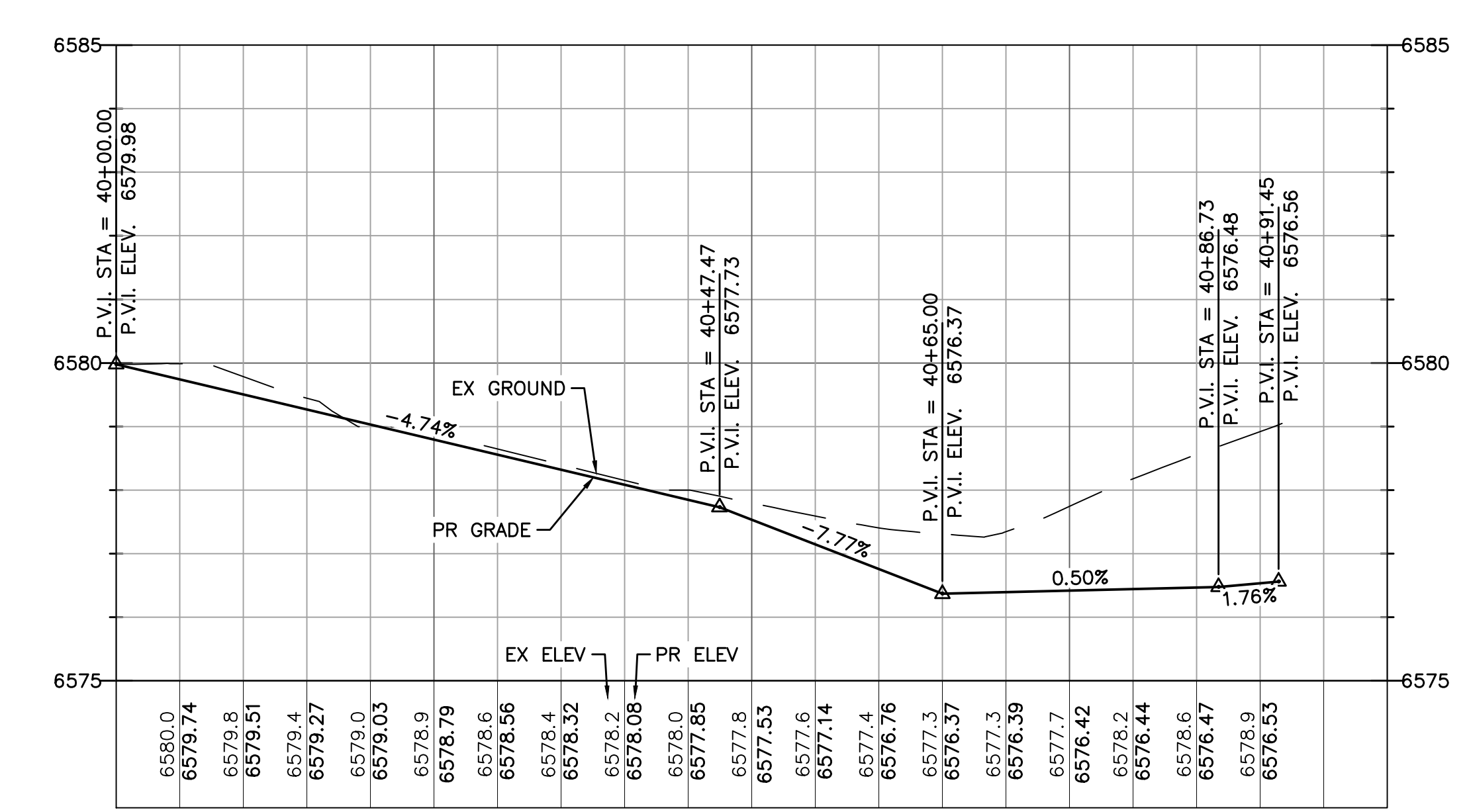

PROFILE FALLOW - NE CORNER CURB FLOWLINE

V:\52876\active\187608744-Mule Deer\CAD\Drawings\10 - Fallow Lane Int1.dwg 2019/12/19 11:12 AM By: Pearce, Taylor

Computer File Information

Creation Date: 4-25-17	Initials: CMD
Last Modification Date:	Initials:
Full Path & Drawing File Name:	
Acad Ver. 2014	Scale: Units: Feet

Index of Revisions

Stantec Consulting Inc.
5725 MARK DABLING BLVD
Suite 190
Colorado Springs, CO 80919
Tel. (719) 594-4535
Fax.
www.stantec.com

GARDENS AT NORTH CAREFREE ROADWAY DETAIL
FALLOW / AKERS INTERSECTION

Designer: CD	Structure Numbers
Detailer: MB	
Sheet Subset:	

Project No./Code	187608744
SHEET	10 OF 34

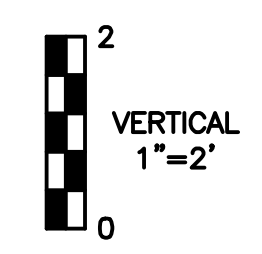
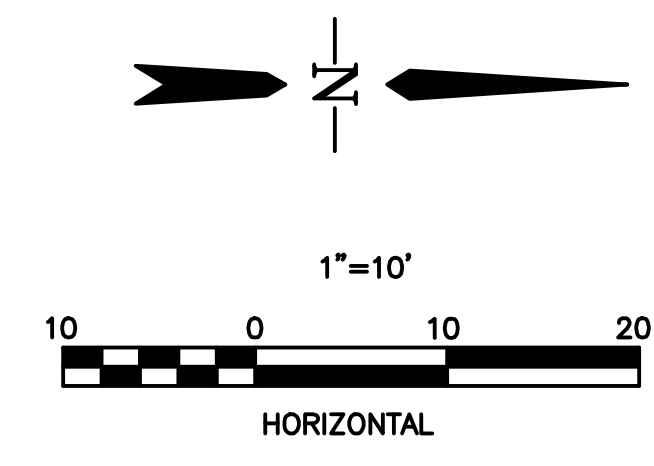
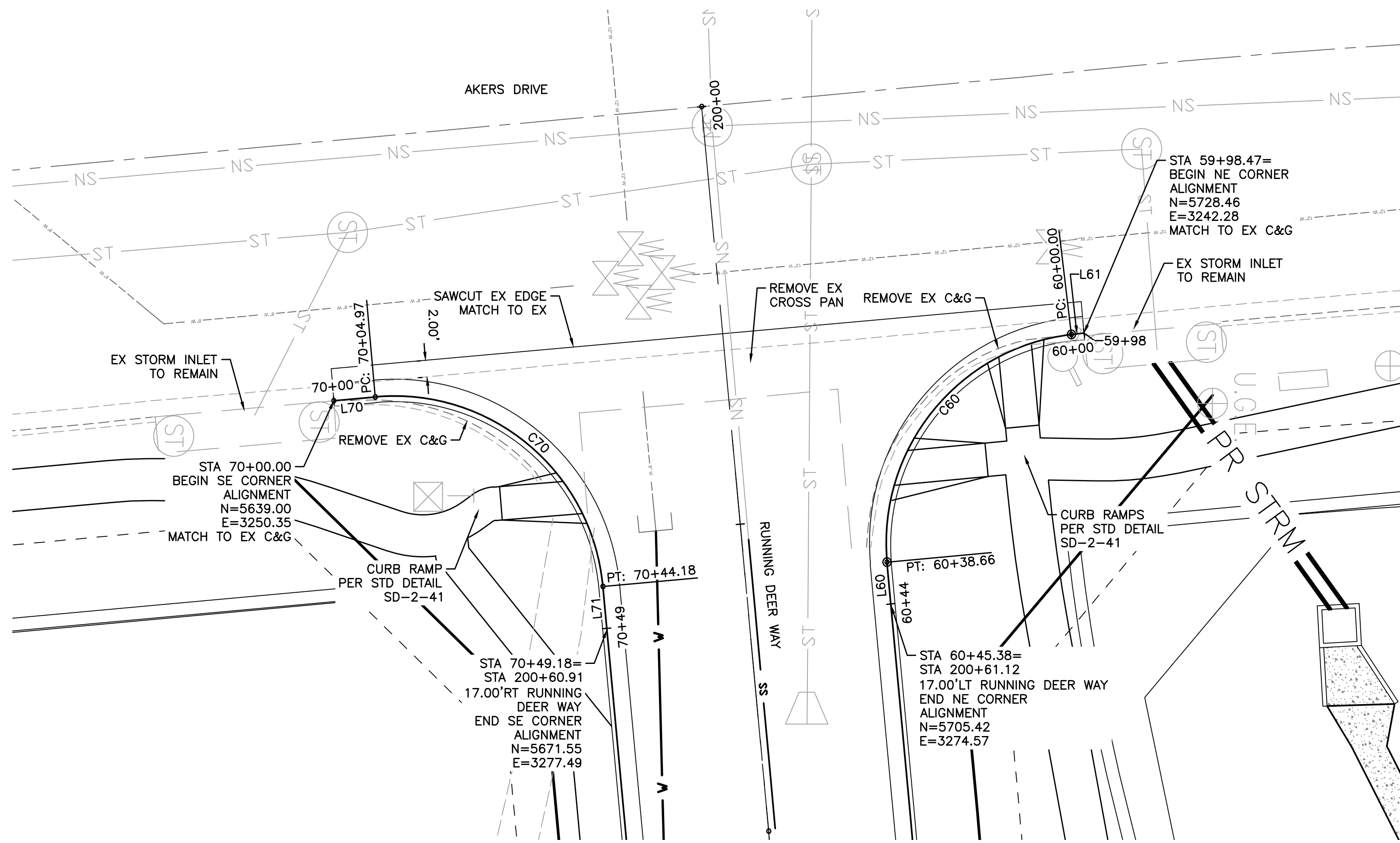

LEGEND

EX MINOR CONTOUR	---
EX MAJOR CONTOUR	----- 5200
EX WATER	---
EX SAN SEWER	---
EX GAS	---
EX STORM SEWER	---
EX WATER VALVE	⊕
EX FIRE HYDRANT	⊕
EX SANITARY SEWER MH	⊕
PR MINOR CONTOUR	---
PR MAJOR CONTOUR	----- 5200
PR ROW	---
PR WATER LINE	W
PR SANITARY SEWER	SS
PR STORM SEWER	---
PR SANITARY SEWER MANHOLE	⊕
PR TYPE R INLET	⊕
PR WATER VALVE	⊕
PR FIRE HYDRANT	⊕

CURVE TABLE: ALIGNMENTS

CURVE #	START STA	END STA	RADIUS	LENGTH	CHORD DIRECTION	DELTA	START POINT (EAST, NORTH)	END POINT (EAST, NORTH)
C60	60+00.00	60+38.66	25.00	38.66	S50° 59' 00.87"E	88.60	(3242.46,5726.94)	(3269.59,5704.96)
C70	70+04.97	70+44.18	25.00	39.22	N39° 46' 47.41"E	89.88	(3249.91,5643.94)	(3272.51,5671.09)

LINE TABLE: ALIGNMENTS

LINE #	LENGTH	START STA	END STA	DIRECTION	START POINT (EAST, NORTH)	END POINT (EAST, NORTH)
L60	5.00	60+38.66	60+43.66	N84° 43' 03.20"E	(3269.59,5704.96)	(3274.57,5705.42)
L61	1.53	59+98.47	60+00.00	S6° 42' 33.61"E	(3242.28,5728.46)	(3242.46,5726.94)
L70	4.97	70+00.00	70+04.97	N5° 02' 48.96"W	(3250.35,5639.00)	(3249.91,5643.94)
L71	5.00	70+44.18	70+49.18	N84° 43' 03.20"E	(3272.51,5671.09)	(3277.49,5671.55)

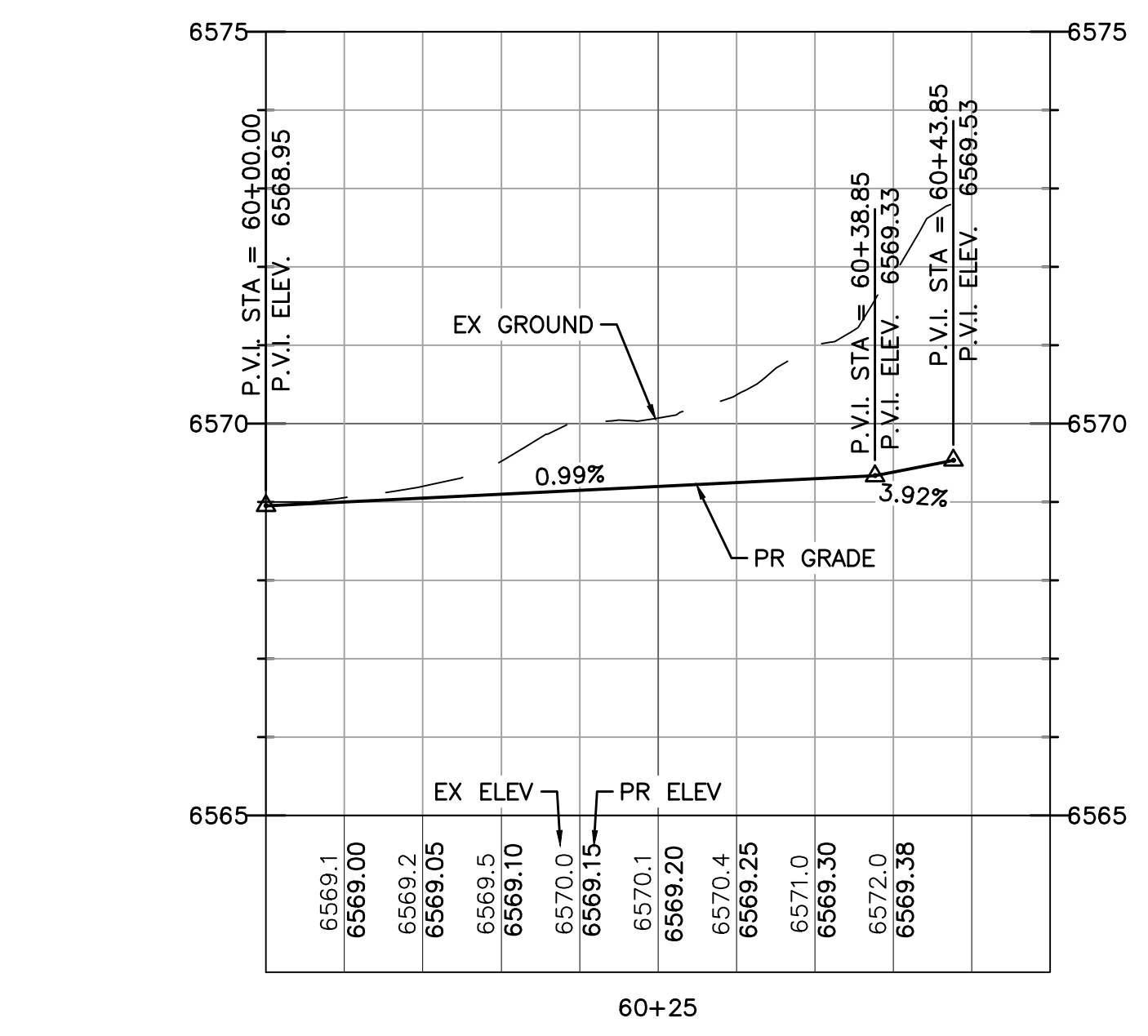
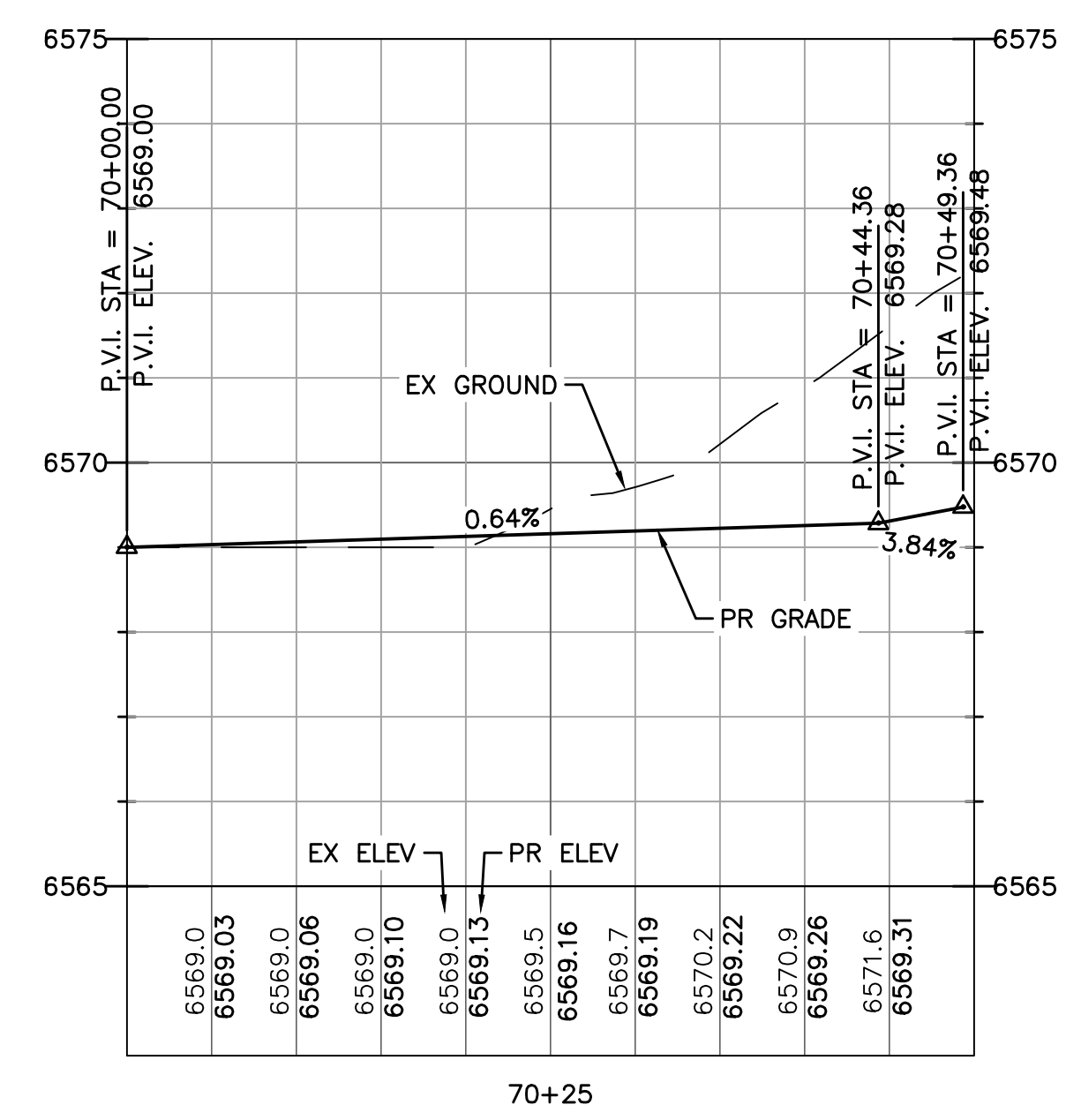

PROFILE RUNNING DEER - SE CORNER CURB FLOWLINE

PROFILE RUNNING DEER - NE CORNER CURB FLOWLINE

V:\52876\active\187608744-Mule Deer\CAD\Sheets\Construction Drawings\11 - Running Deer Way Int2.dwg 2019/12/19 11:14 AM By: Pearce, Taylor

Computer File Information

Creation Date: 4-25-17	Initials: CMD
Last Modification Date:	Initials:
Full Path & Drawing File Name:	
Acad Ver. 2014	Scale: Units: Feet

Index of Revisions

Stantec Consulting Inc.
5725 MARK DABLING BLVD
Suite 190
Colorado Springs, CO 80919
Tel. (719) 594-4535
Fax.
www.stantec.com

GARDENS AT NORTH CAREFREE ROADWAY DETAIL

RUNNING DEER / AKERS INTERSECTION

Designer: CD	Structure Numbers
Detailer: MB	
Sheet Subset:	

Project No./Code	187608744
SHEET 11 OF 34	

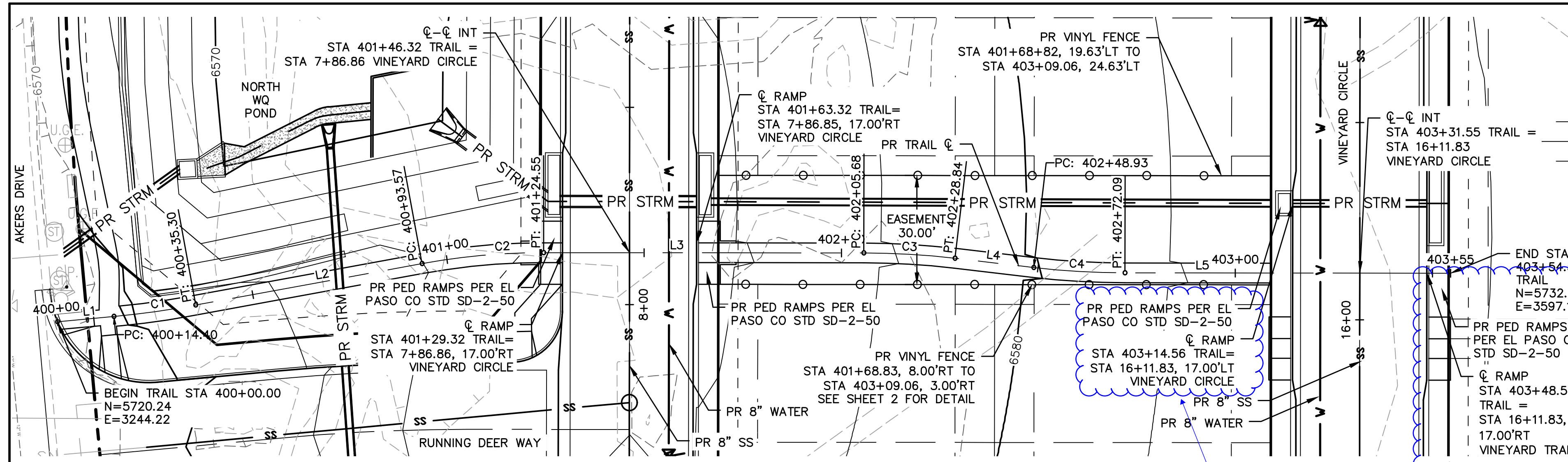

CURVE #	START STA	END STA	RADIUS	LENGTH	CHORD DIRECTION	DELTA	START POINT (EAST, NORTH)	END POINT (EAST, NORTH)
C1	400+14.40	400+35.30	240.00	20.91	N82° 06' 19.62"E	4.99	(3258.55,5721.59)	(3279.25,5724.46)
C2	400+93.57	401+24.55	170.00	30.98	N84° 49' 47.75"E	10.44	(3336.57,5734.97)	(3367.37,5737.76)
C3	402+05.68	402+28.84	200.00	23.16	S86° 37' 58.60"E	6.63	(3448.50,5737.69)	(3471.61,5736.33)
C4	402+48.93	402+72.09	200.00	23.16	S86° 37' 58.60"E	6.63	(3491.57,5733.99)	(3514.67,5732.63)

LINE #	LENGTH	START STA	END STA	DIRECTION	START POINT (EAST, NORTH)	END POINT (EAST, NORTH)
L1	14.40	400+00.00	400+14.40	N84° 36' 03.34"E	(3244.22,5720.24)	(3258.55,5721.59)
L2	58.27	400+35.30	400+93.57	N79° 36' 35.91"E	(3279.25,5724.46)	(3336.57,5734.97)
L3	81.13	401+24.55	402+05.68	S89° 57' 00.42"E	(3367.37,5737.76)	(3448.50,5737.69)
L4	20.09	402+28.84	402+48.93	S83° 18' 56.78"E	(3471.61,5736.33)	(3491.57,5733.99)
L5	82.47	402+72.09	403+54.56	S89° 57' 00.42"E	(3514.67,5732.63)	(3597.14,5732.56)

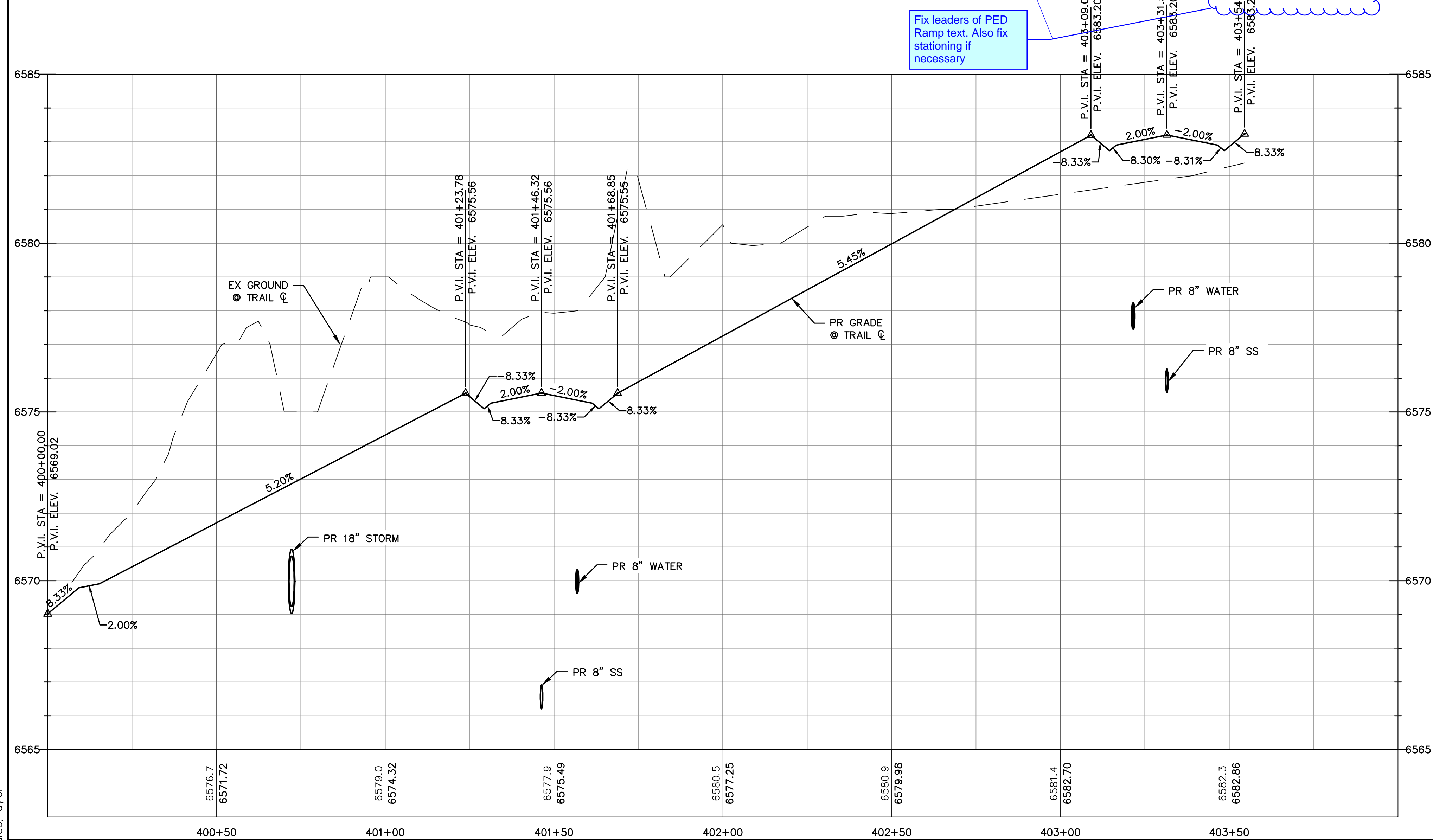

Fix leaders of PED Ramp text. Also fix stationing if necessary

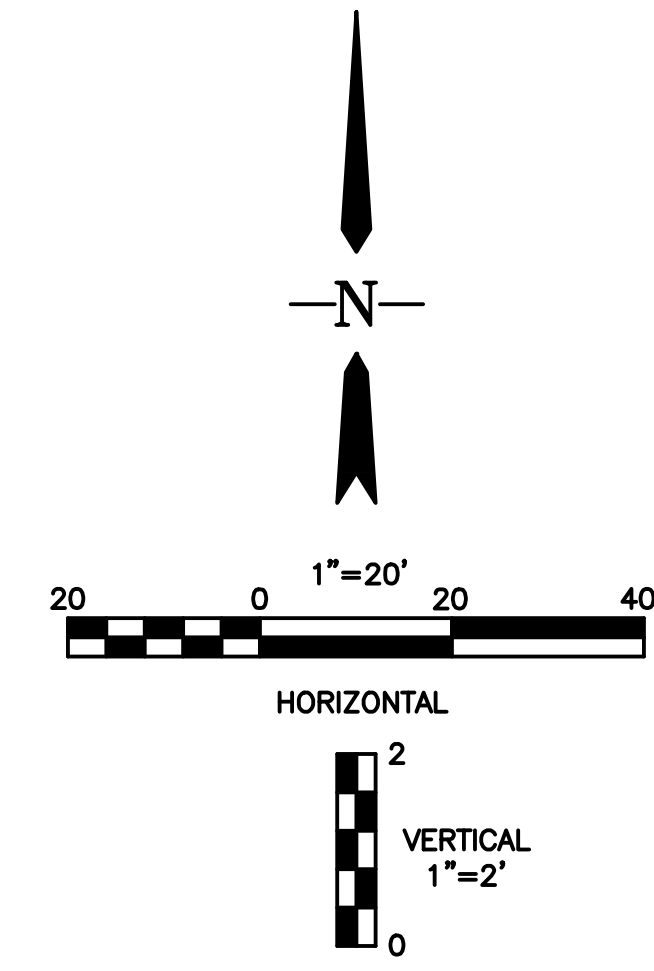

LEGEND

- EX MINOR CONTOUR -----
- EX MAJOR CONTOUR ----- 5200 -----
- EX WATER ----- W -----
- EX SAN SEWER ----- SN -----
- EX GAS ----- G -----
- EX STORM SEWER ----- S -----
- EX WATER VALVE -----
- EX FIRE HYDRANT -----
- EX SANITARY SEWER MH -----
- PR MINOR CONTOUR -----
- PR MAJOR CONTOUR ----- 5200 -----
- PR ROW -----
- PR WATER LINE ----- W -----
- PR SANITARY SEWER ----- SS -----
- PR STORM SEWER ----- PR STORM -----
- PR SANITARY SEWER MANHOLE -----
- PR TYPE R INLET -----
- PR WATER VALVE -----
- PR FIRE HYDRANT -----

V:\52876\active\187608744-Mule Deer\CAD\Sheets\Construction Drawings\12 - PnP Trail.dwg 2019/12/19 1:48 PM By: Pearce, Taylor

Creation Date: 4-25-17	Initials: CMD
Last Modification Date:	Initials:
Full Path & Drawing File Name:	
Acad Ver. 2014	Scale: Units: Feet

NO.	DATE	DESCRIPTION

Stantec Consulting Inc.
5725 MARK DABLING BLVD
Suite 190
Colorado Springs, CO 80919
Tel. (719) 594-4535
Fax.
www.stantec.com

Designer: CD	Structure Numbers
Detailer: MB	
Sheet Subst:	

Project No./Code	187608744
SHEET	12 OF 34

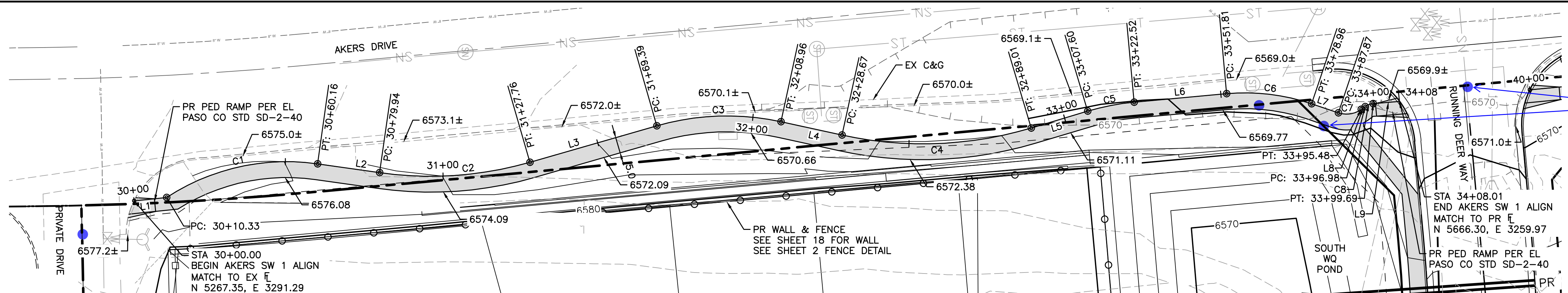

LEGEND

- EX MINOR CONTOUR
- EX MAJOR CONTOUR
- EX WATER
- EX SAN SEWER
- EX GAS
- EX STORM SEWER
- EX WATER VALVE
- EX FIRE HYDRANT
- EX SANITARY SEWER MH
- PR MINOR CONTOUR
- PR MAJOR CONTOUR
- PR ROW
- PR WATER LINE
- PR SANITARY SEWER
- PR STORM SEWER
- PR SANITARY SEWER MANHOLE
- PR TYPE R INLET
- PR WATER VALVE
- PR FIRE HYDRANT

LINE TABLE: ALIGNMENTS

LINE #	LENGTH	START STA	END STA	DIRECTION	START POINT (EAST, NORTH)	END POINT (EAST, NORTH)
L1	10.33	30+00.00	30+10.33	N5° 52' 51.48"W	(3291.29,5267.35)	(3290.23,5277.63)
L2	19.78	30+60.16	30+79.94	N8° 06' 32.42"E	(3279.62,5325.21)	(3282.41,5344.79)
L3	41.64	31+27.76	31+69.39	N16° 01' 46.61"W	(3279.13,5392.14)	(3267.63,5432.16)
L4	19.71	32+08.96	32+28.67	N12° 18' 33.02"E	(3266.36,5471.31)	(3270.56,5490.56)
L5	18.59	32+89.01	33+07.60	N16° 37' 14.74"W	(3268.32,5550.22)	(3263.00,5568.03)
L6	29.29	33+22.52	33+51.81	N5° 13' 24.80"W	(3260.18,5582.66)	(3257.51,5611.82)
L7	8.91	33+78.96	33+87.87	N18° 42' 40.48"E	(3260.67,5638.59)	(3263.53,5647.04)
L8	1.51	33+95.48	33+96.98	N35° 44' 44.35"W	(3262.45,5654.28)	(3261.57,5655.50)
L9	8.32	33+99.69	34+08.01	N4° 41' 02.11"W	(3260.65,5658.01)	(3259.97,5666.30)

AKERS SIDEWALK 1

CURVE TABLE: ALIGNMENTS

CURVE #	START STA	END STA	RADIUS	LENGTH	CHORD DIRECTION	DELTA	START POINT (EAST, NORTH)	END POINT (EAST, NORTH)
C1	30+10.33	30+60.16	69.00	49.82	N12° 34' 36.38"W	41.37	(3290.23,5277.63)	(3279.62,5325.21)
C2	30+79.94	31+27.76	113.50	47.82	N3° 57' 37.09"W	24.14	(3282.41,5344.79)	(3279.13,5392.14)
C3	31+69.39	32+08.96	80.00	39.57	N1° 51' 36.79"W	28.34	(3267.63,5432.16)	(3266.36,5471.31)
C4	32+28.67	32+89.01	119.50	60.34	N2° 09' 20.86"W	28.93	(3270.56,5490.56)	(3268.32,5550.22)
C5	33+07.60	33+22.52	75.00	14.92	N10° 55' 19.77"W	11.40	(3263.00,5568.03)	(3260.18,5582.66)
C6	33+51.81	33+78.96	65.00	27.15	N6° 44' 37.84"E	23.93	(3257.51,5611.82)	(3260.67,5638.59)
C7	33+87.87	33+95.48	8.00	7.60	N8° 31' 01.94"W	54.46	(3263.53,5647.04)	(3262.45,5654.28)
C8	33+96.98	33+99.69	5.00	2.71	N20° 12' 53.23"W	31.06	(3261.57,5655.50)	(3260.65,5658.01)

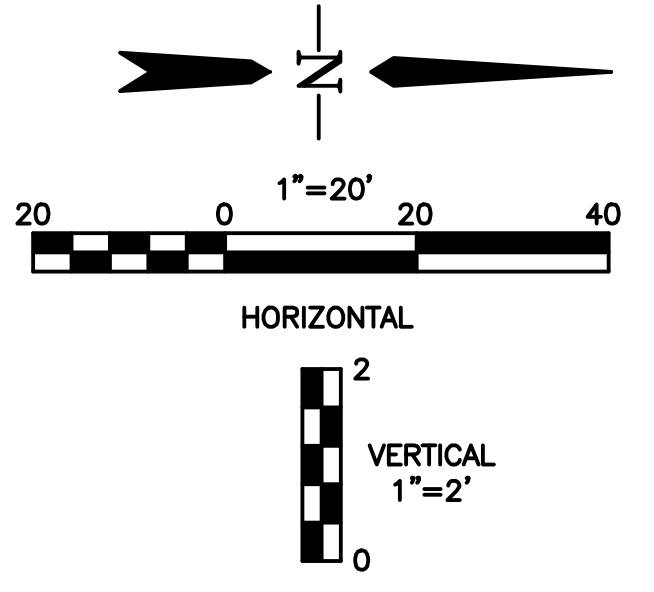
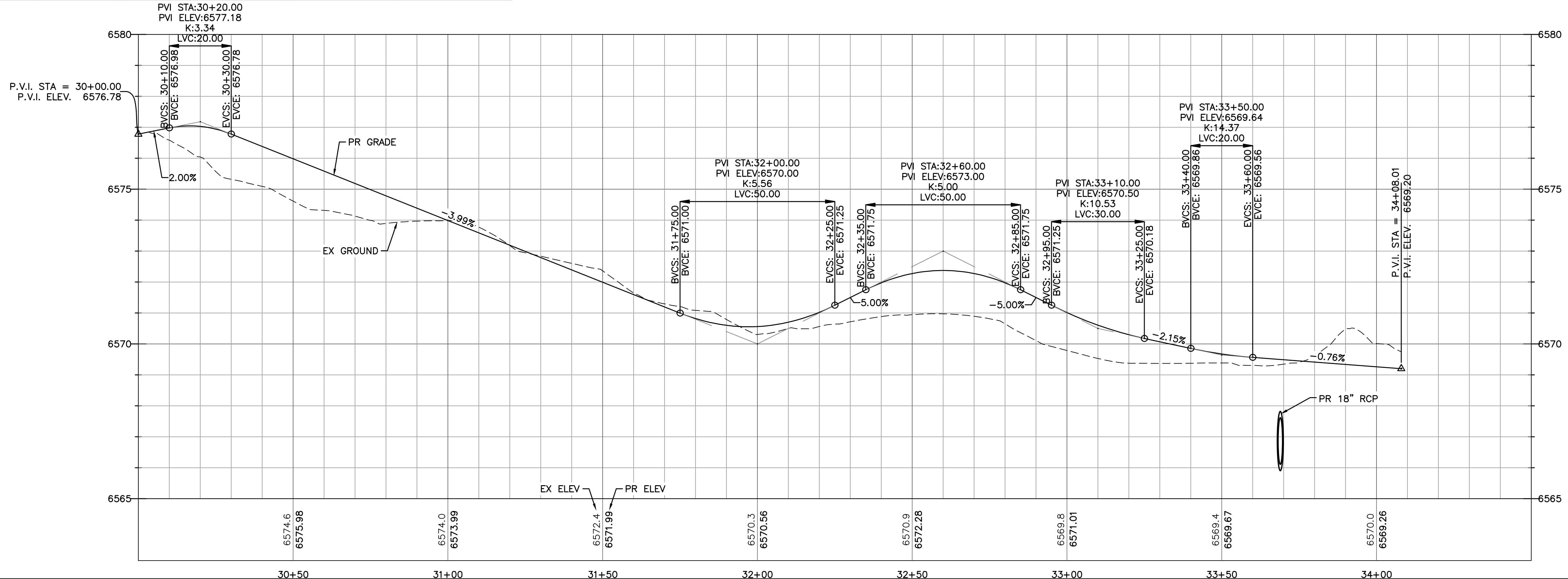

- NOTE:**
- ELEVATIONS ARE AT 50' INTERVALS UNLESS OTHERWISE NOTED.
 - EXISTING ELEVATIONS ARE AT TOP BACK OF EXISTING CURB.

V:\52876\active\187608744-Mule Deer\CAD\Sheets\Construction Drawings\13 - PrP Sidewalks.dwg
2019/12/19 11:25 AM By: Pearce, Taylor

Computer File Information		Index of Revisions		<p>Stantec Stantec Consulting Inc. 5725 MARK DABLING BLVD Suite 190 Colorado Springs, CO 80919 Tel. (719) 594-4535 Fax. www.stantec.com</p>	GARDENS AT NORTH CAREFREE PLAN AND PROFILE AKERS SIDEWALK 1		Project No./Code			
Creation Date: 4-25-17					Designer: CD		Structure Numbers		187608744	
Last Modification Date:									Detailer: MB	
Full Path & Drawing File Name:					Sheet Subst:					
Acad Ver. 2014		Scale:		Units: Feet						

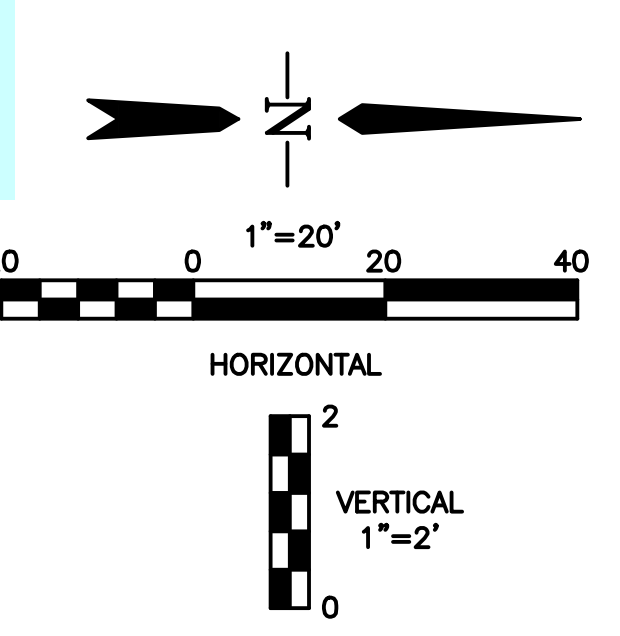
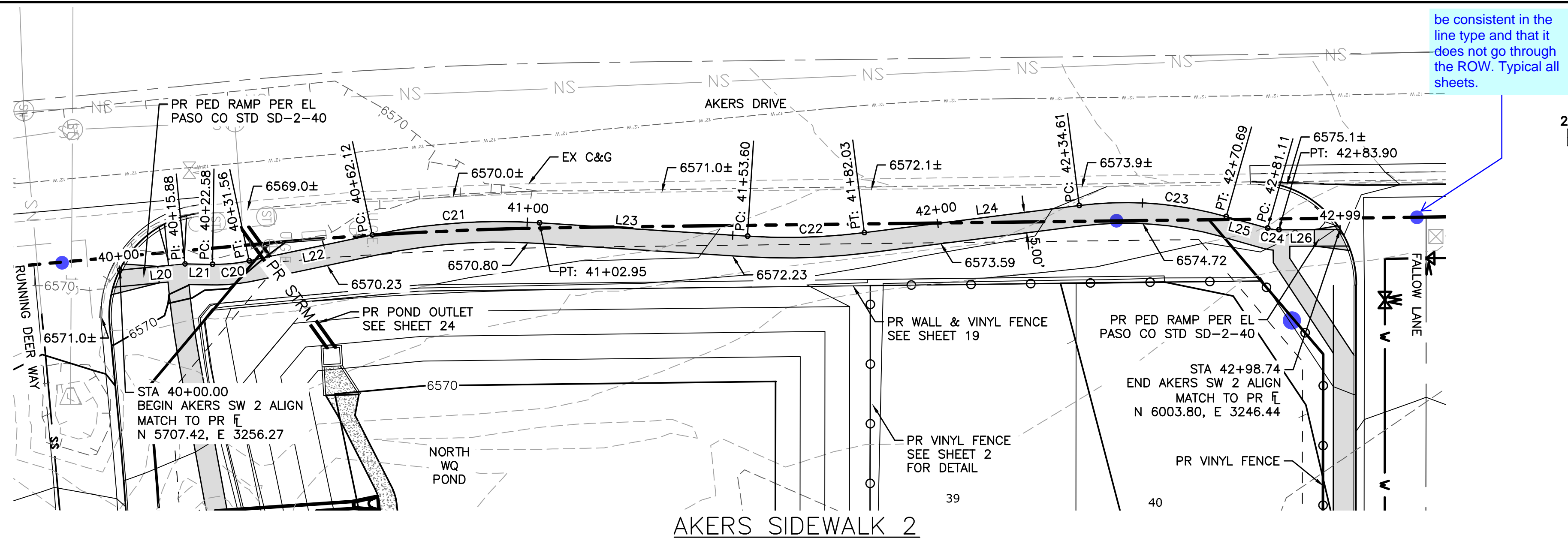

LEGEND

EX MINOR CONTOUR	---
EX MAJOR CONTOUR	---
EX WATER	---
EX SAN SEWER	---
EX GAS	---
EX STORM SEWER	---
EX WATER VALVE	---
EX FIRE HYDRANT	---
EX SANITARY SEWER MH	---
PR MINOR CONTOUR	---
PR MAJOR CONTOUR	---
PR ROW	---
PR WATER LINE	---
PR SANITARY SEWER	---
PR STORM SEWER	---
PR SANITARY SEWER MANHOLE	---
PR TYPE R INLET	---
PR WATER VALVE	---
PR FIRE HYDRANT	---

NOTE:

- ELEVATIONS ARE AT 50' INTERVALS UNLESS OTHERWISE NOTED.
- EXISTING ELEVATIONS ARE AT TOP BACK OF EXISTING CURB.

AKERS SIDEWALK 2

LINE TABLE: ALIGNMENTS

LINE #	LENGTH	START STA	END STA	DIRECTION	START POINT (EAST, NORTH)	END POINT (EAST, NORTH)
L20	15.88	40+00.00	40+15.88	N5° 23' 59.80"W	(3256.27,5707.42)	(3254.78,5723.23)
L21	6.70	40+15.88	40+22.58	N1° 04' 58.31"E	(3254.78,5723.23)	(3254.90,5729.94)
L22	30.56	40+31.56	40+62.12	N11° 55' 15.90"W	(3254.05,5738.85)	(3247.73,5768.76)
L23	50.65	41+02.95	41+53.60	N3° 40' 19.45"E	(3244.81,5809.35)	(3248.05,5859.89)
L24	52.59	41+82.03	42+34.61	N7° 11' 19.06"W	(3247.18,5888.27)	(3240.60,5940.44)
L25	10.43	42+70.69	42+81.11	N15° 46' 35.06"E	(3243.28,5976.17)	(3246.12,5986.21)
L26	14.84	42+83.90	42+98.74	N0° 11' 30.21"W	(3246.49,5988.96)	(3246.44,6003.80)

CURVE TABLE: ALIGNMENTS

CURVE #	START STA	END STA	RADIUS	LENGTH	CHORD DIRECTION	DELTA	START POINT (EAST, NORTH)	END POINT (EAST, NORTH)
C20	40+22.58	40+31.56	40.00	8.98	N5° 29' 29.94"W	12.86	(3254.90,5729.94)	(3254.05,5738.85)
C21	40+62.12	41+02.95	150.00	40.82	N4° 07' 28.22"W	15.59	(3247.73,5768.76)	(3244.81,5809.35)
C22	41+53.60	41+82.03	150.00	28.43	N1° 45' 29.80"W	10.86	(3248.05,5859.89)	(3247.18,5888.27)
C23	42+34.61	42+70.69	90.00	36.07	N4° 17' 38.00"E	22.97	(3240.60,5940.44)	(3243.28,5976.17)
C24	42+81.11	42+83.90	10.00	2.79	N7° 47' 32.43"E	15.97	(3246.12,5986.21)	(3246.49,5988.96)

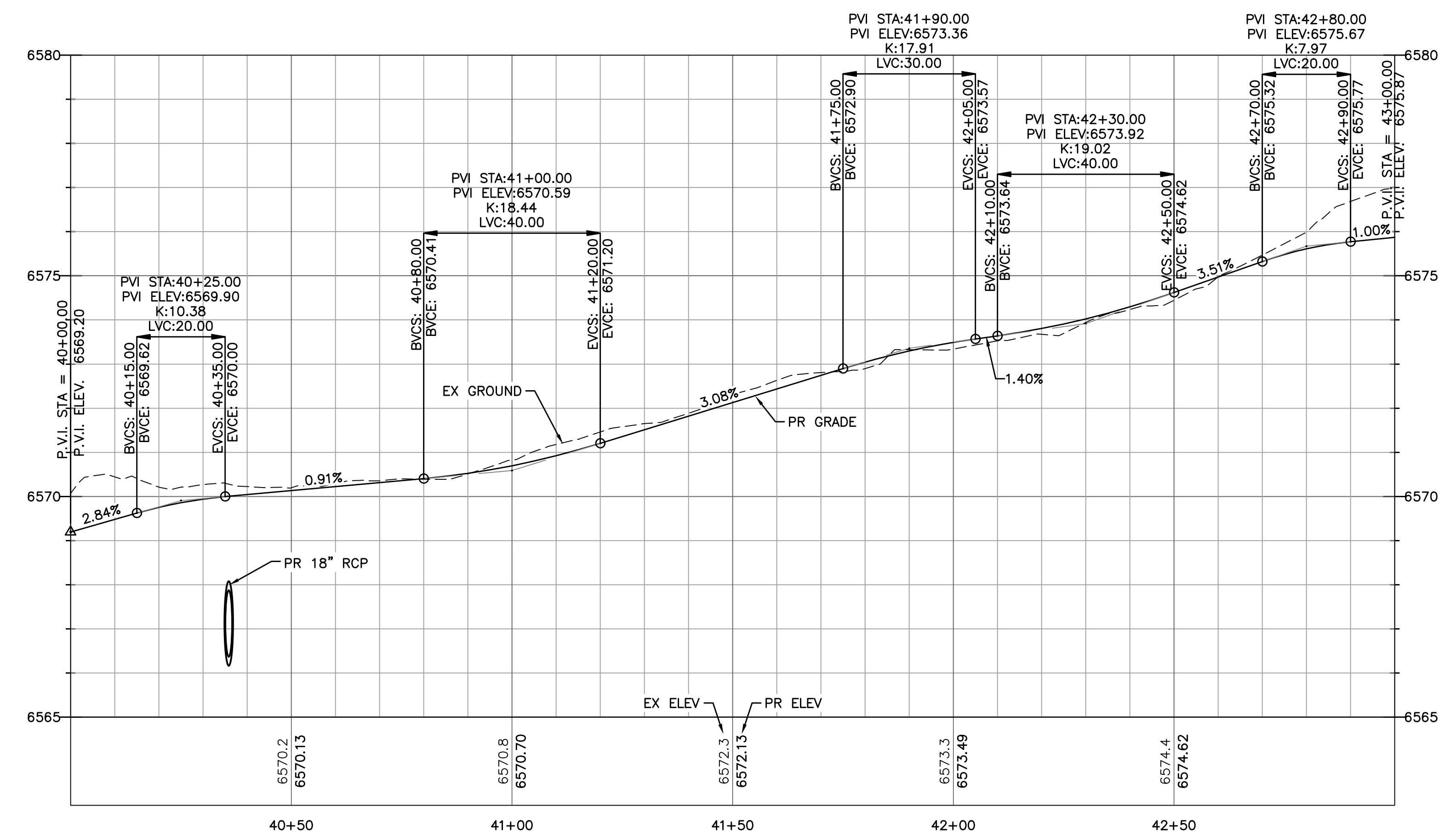

V:\52876\active\187608744-Mule Deer\CAD\Drawings\13 - PrP Sidewalks.dwg 2019/12/19 11:22 AM By: Pearce, Taylor

Computer File Information

Creation Date: 4-25-17	Initials: CMD	
Last Modification Date:	Initials:	
Full Path & Drawing File Name:		
Acad Ver. 2014	Scale:	Units: Feet

Index of Revisions

Stantec Consulting Inc.
5725 MARK DABLING BLVD
Suite 190
Colorado Springs, CO 80919
Tel. (719) 594-4535
Fax:
www.stantec.com

**GARDENS AT NORTH CAREFREE
PLAN AND PROFILE
AKERS SIDEWALK 2**

Designer: CD	Structure Numbers:
Detailer: MB	
Sheet Subset:	

Project No./Code

187608744

SHEET 14 OF 34

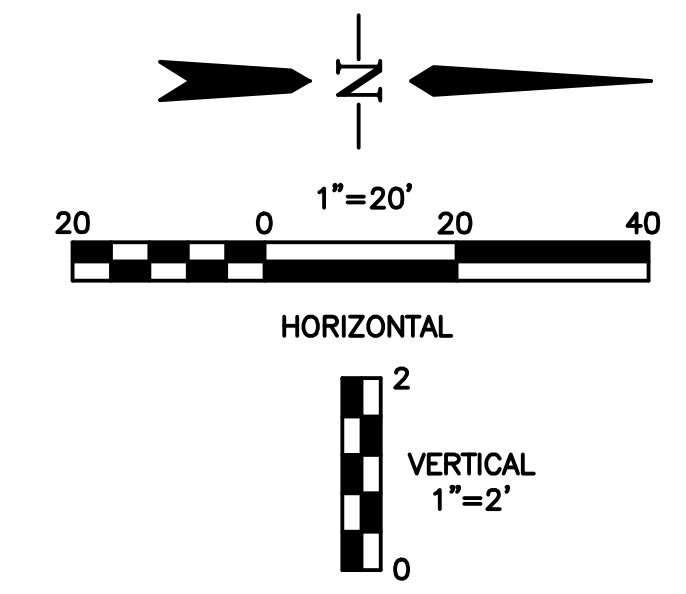
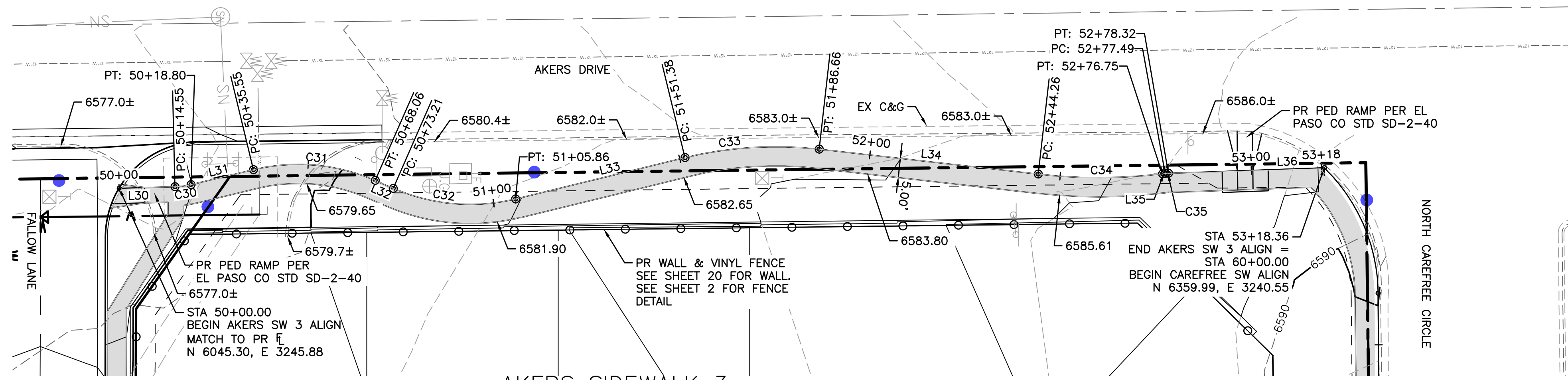

LEGEND

EX MINOR CONTOUR	---
EX MAJOR CONTOUR	---
EX WATER	---
EX SAN SEWER	---
EX GAS	---
EX STORM SEWER	---
EX WATER VALVE	---
EX FIRE HYDRANT	---
EX SANITARY SEWER MH	---
PR MINOR CONTOUR	---
PR MAJOR CONTOUR	---
PR ROW	---
PR WATER LINE	---
PR SANITARY SEWER	---
PR STORM SEWER	---
PR SANITARY SEWER MANHOLE	---
PR TYPE R INLET	---
PR WATER VALVE	---
PR FIRE HYDRANT	---

NOTE:

- ELEVATIONS ARE AT 50' INTERVALS UNLESS OTHERWISE NOTED.
- EXISTING ELEVATIONS ARE AT TOP BACK OF EXISTING CURB.

AKERS SIDEWALK 3

CURVE TABLE: ALIGNMENTS

CURVE #	START STA	END STA	RADIUS	LENGTH	CHORD DIRECTION	DELTA	START POINT (EAST, NORTH)	END POINT (EAST, NORTH)
C30	50+14.55	50+18.80	20.00	4.25	N7° 28' 31.86"W	12.17	(3245.52,6059.84)	(3244.97,6064.05)
C31	50+35.55	50+68.06	50.00	32.51	N5° 04' 01.70"E	37.26	(3241.04,6080.33)	(3243.86,6112.15)
C32	50+73.21	51+05.86	50.00	32.65	N4° 59' 17.71"E	37.42	(3245.93,6116.86)	(3248.72,6148.81)
C33	51+51.38	51+86.66	100.00	35.28	N3° 36' 47.53"W	20.21	(3237.92,6193.04)	(3235.71,6228.06)
C34	52+44.26	52+76.75	140.00	32.49	N0° 09' 18.21"W	13.30	(3242.23,6285.30)	(3242.14,6317.71)
C35	52+77.49	52+78.32	10.00	0.83	N4° 24' 57.69"W	4.78	(3242.05,6318.44)	(3241.99,6319.27)

LINE TABLE: ALIGNMENTS

LINE #	LENGTH	START STA	END STA	DIRECTION	START POINT (EAST, NORTH)	END POINT (EAST, NORTH)
L30	14.55	50+00.00	50+14.55	N1° 23' 19.58"W	(3245.88,6045.30)	(3245.52,6059.84)
L31	16.75	50+18.80	50+35.55	N13° 33' 44.15"W	(3244.97,6064.05)	(3241.04,6080.33)
L32	5.14	50+68.06	50+73.21	N23° 41' 47.54"E	(3243.86,6112.15)	(3245.93,6116.86)
L33	45.52	51+05.86	51+51.38	N13° 43' 12.12"W	(3248.72,6148.81)	(3237.92,6193.04)
L34	57.60	51+86.66	52+44.26	N6° 29' 37.06"E	(3235.71,6228.06)	(3242.23,6285.30)
L35	0.74	52+76.75	52+77.49	N6° 48' 13.49"W	(3242.14,6317.71)	(3242.05,6318.44)
L36	28.63	52+90.43	53+18.36	N2° 01' 41.88"W	(3241.56,6331.38)	(3240.55,6359.99)

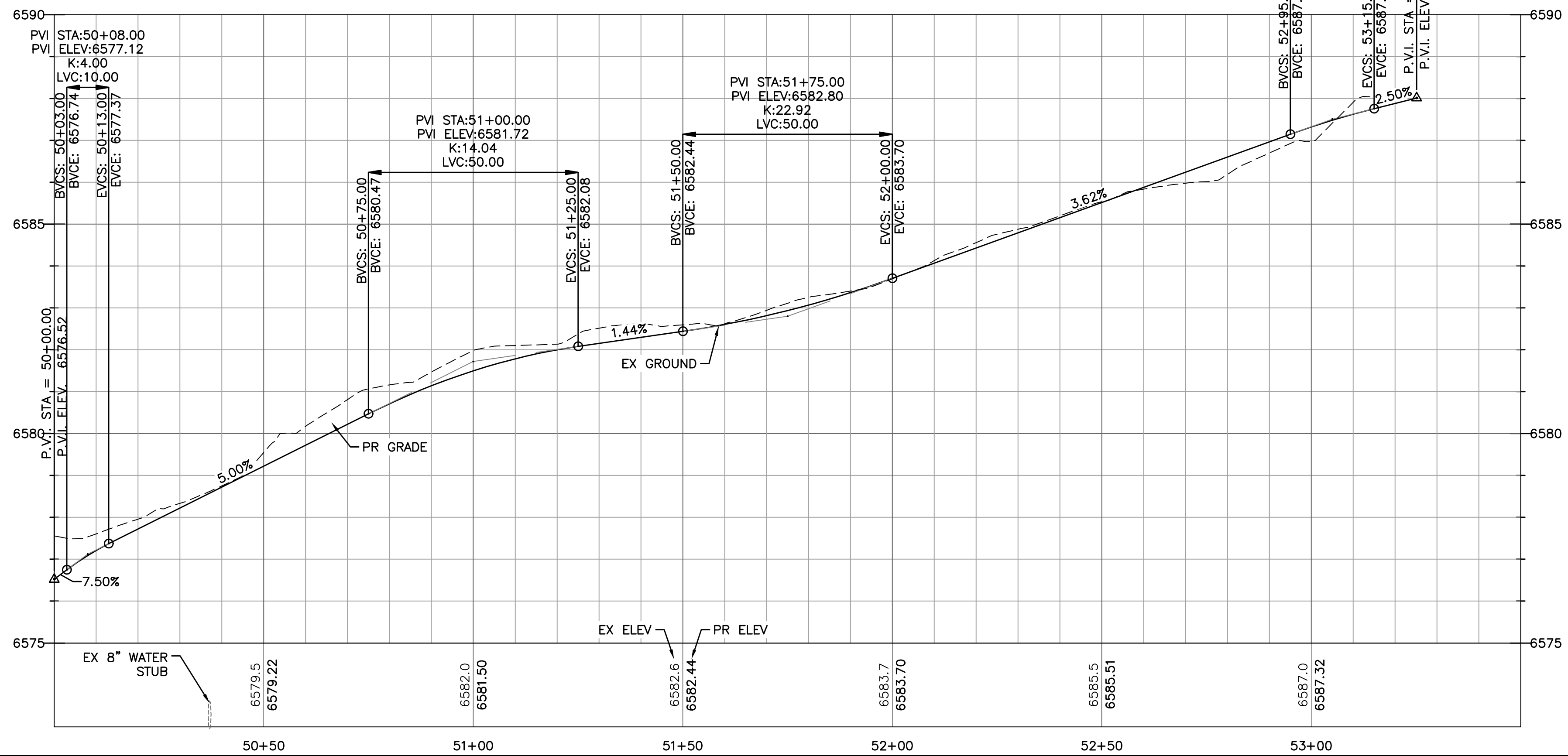

V:\52876\active\187608744-Mule Deer\CAD\Drawings\13--Prp Sidewalks.dwg 2019/12/19 11:21 AM By: Pearce, Taylor

Computer File Information	
Creation Date: 4-25-17	Initials: CMD
Last Modification Date:	Initials:
Full Path & Drawing File Name:	
Acad Ver. 2014	Scale: Units: Feet

Index of Revisions	

Stantec Consulting Inc.
5725 MARK DABLING BLVD
Suite 190
Colorado Springs, CO 80919
Tel. (719) 594-4535
Fax.
www.stantec.com

GARDENS AT NORTH CAREFREE PLAN AND PROFILE AKERS SIDEWALK 3	
Designer: CD	Structure Numbers
Detailer: MB	
Sheet Subset:	

Project No./Code
187608744
SHEET 15 OF 34

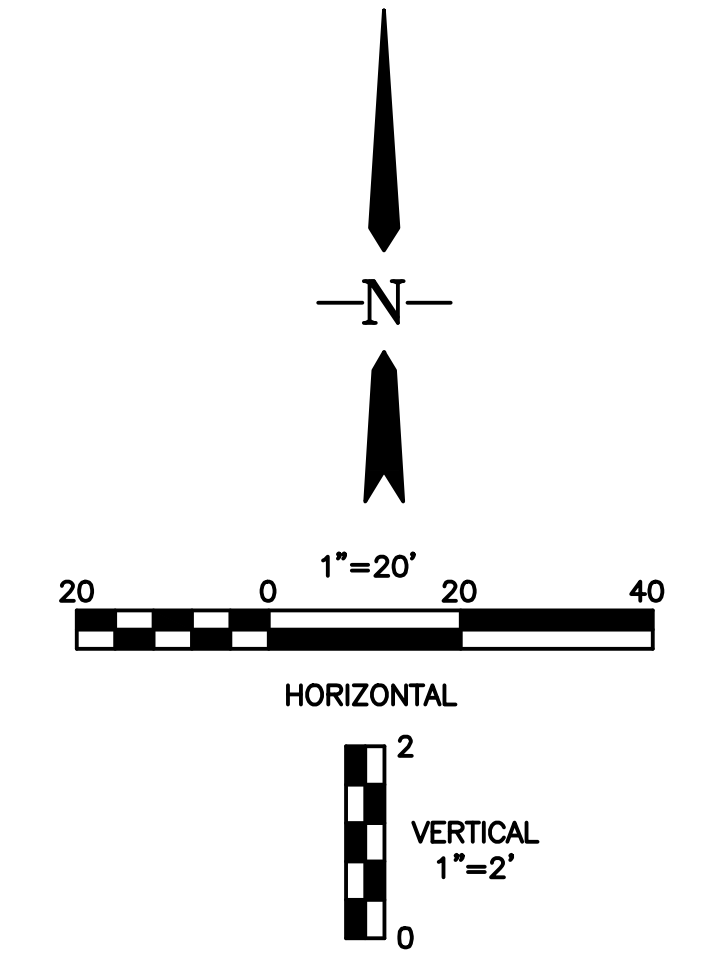
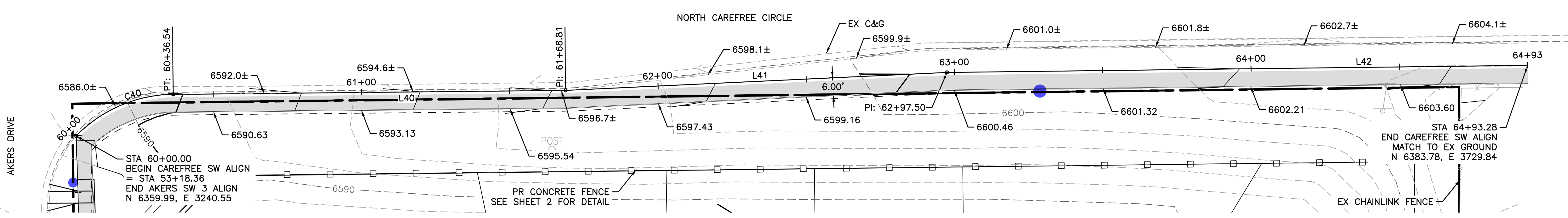

LINE TABLE: ALIGNMENTS

LINE #	LENGTH	START STA	END STA	DIRECTION	START POINT (EAST, NORTH)	END POINT (EAST, NORTH)
L40	132.26	60+36.54	61+68.81	N89° 25' 22.25"E	(3273.27,6374.00)	(3405.53,6375.34)
L41	128.69	61+68.81	62+97.50	N87° 17' 49.56"E	(3405.53,6375.34)	(3534.08,6381.40)
L42	195.78	62+97.50	64+93.28	N89° 18' 20.21"E	(3534.08,6381.40)	(3729.84,6383.78)

CAREFREE SIDEWALK

CURVE TABLE: ALIGNMENTS

CURVE #	START STA	END STA	RADIUS	LENGTH	CHORD DIRECTION	DELTA	START POINT (EAST, NORTH)	END POINT (EAST, NORTH)
C40	60+00.00	60+36.54	46.30	36.54	N66° 48' 46.98"E	45.22	(3240.55,6359.99)	(3273.27,6374.00)

NOTE:

- ELEVATIONS ARE AT 50' INTERVALS UNLESS OTHERWISE NOTED.
- EXISTING ELEVATIONS ARE AT TOP BACK OF EXISTING CURB.

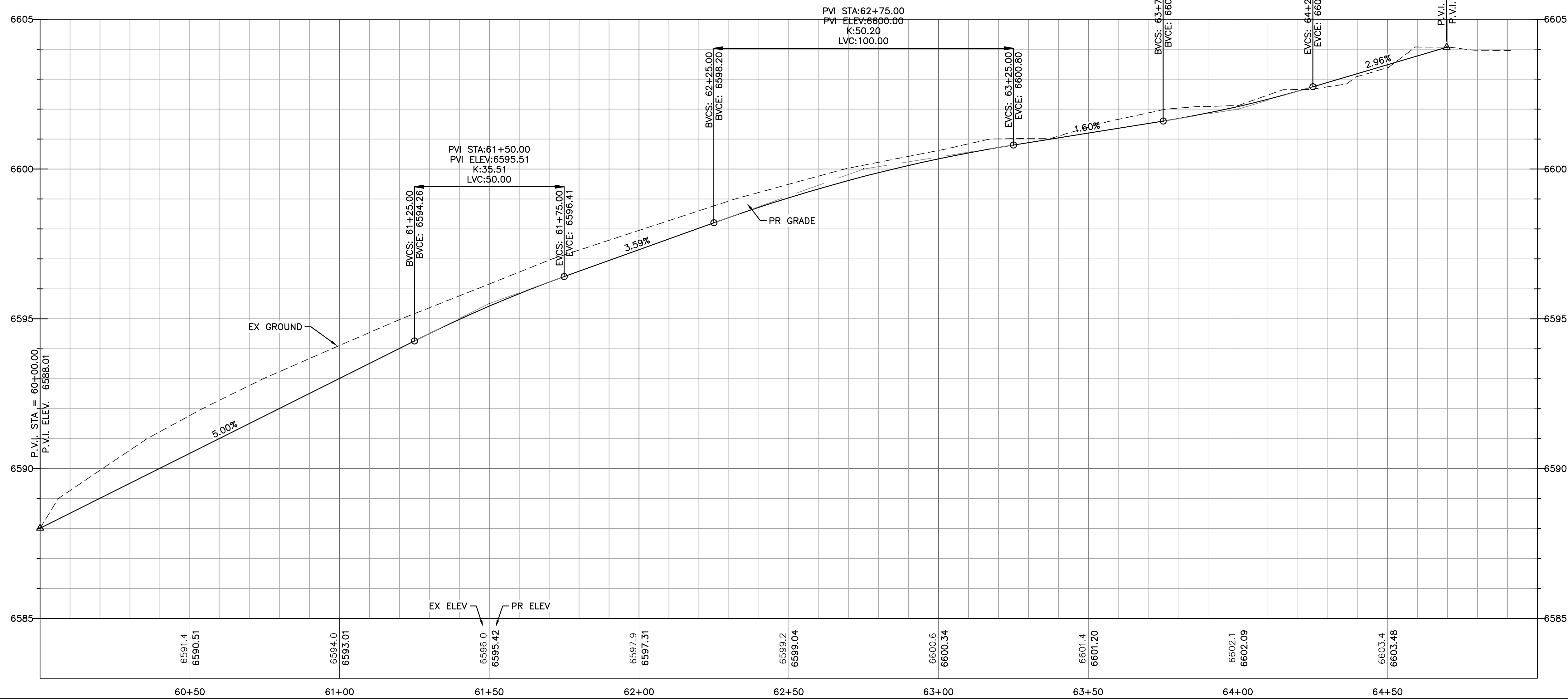

LEGEND

EX MINOR CONTOUR	---
EX MAJOR CONTOUR	-----
EX WATER	---
EX SAN SEWER	---
EX GAS	---
EX STORM SEWER	---
EX WATER VALVE	⊕
EX FIRE HYDRANT	⊕
EX SANITARY SEWER MH	⊕
PR MINOR CONTOUR	---
PR MAJOR CONTOUR	-----
PR ROW	=====
PR WATER LINE	---
PR SANITARY SEWER	---
PR STORM SEWER	---
PR SANITARY SEWER MANHOLE	⊕
PR TYPE R INLET	⊕
PR WATER VALVE	⊕
PR FIRE HYDRANT	⊕

V:\52876\active\187608744-Mule Deer\CAD\Sheets\Construction Drawings\13--Prp Sidewalks.dwg
2019/12/19 11:20 AM By: Pearce, Taylor

Computer File Information

Creation Date: 4-25-17	Initials: CMD
Last Modification Date:	Initials:
Full Path & Drawing File Name:	
Acad Ver. 2014	Scale: Units: Feet

Index of Revisions

NO.	DESCRIPTION	DATE	BY

Stantec
Stantec Consulting Inc.
5725 MARK DABLING BLVD
Suite 190
Colorado Springs, CO 80919
Tel. (719) 594-4535
Fax.
www.stantec.com

**GARDENS AT NORTH CAREFREE
PLAN AND PROFILE
CAREFREE SIDEWALK**

Designer: CD	Structure Numbers:
Detailer: MB	
Sheet Subst:	

Project No./Code
187608744

SHEET 16 OF 34

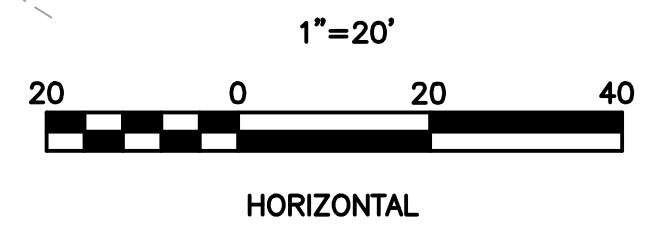
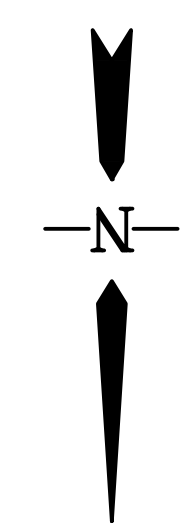
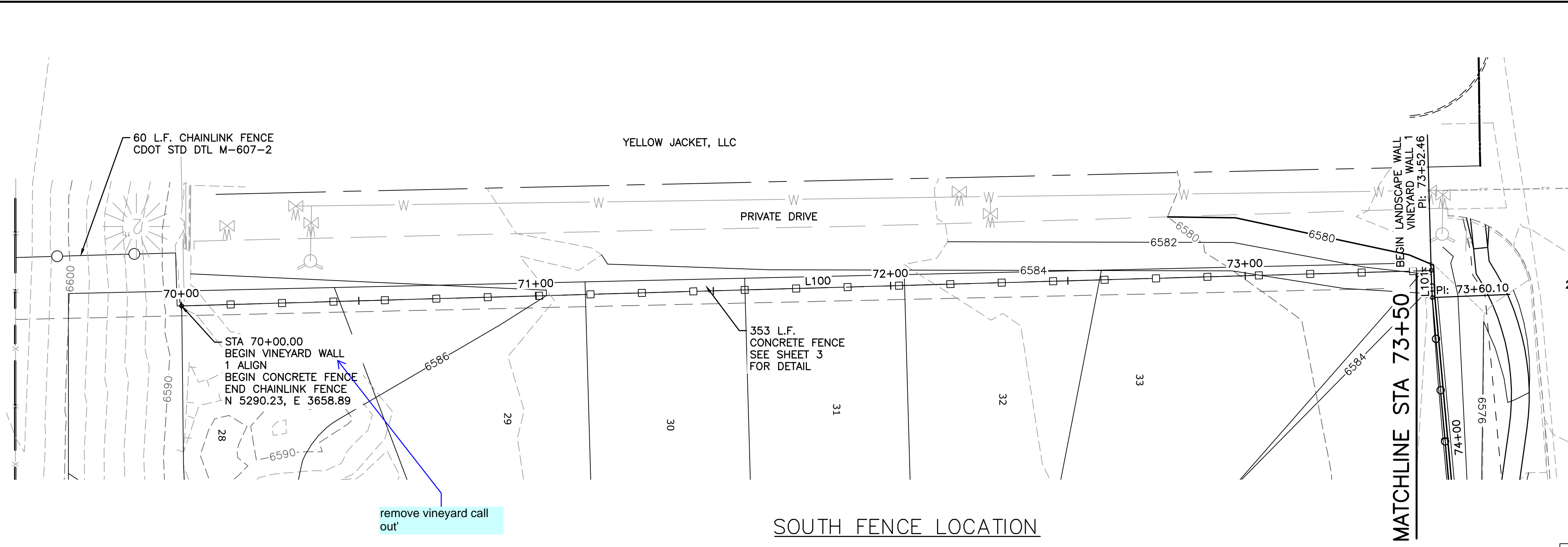

LEGEND

EX MINOR CONTOUR	---
EX MAJOR CONTOUR	----- 5200
EX WATER	--- W ---
EX SAN SEWER	--- SN ---
EX GAS	--- G ---
EX STORM SEWER	--- SN ---
EX WATER VALVE	
EX FIRE HYDRANT	
EX SANITARY SEWER MH	
PR MINOR CONTOUR	---
PR MAJOR CONTOUR	----- 5200
PR ROW	=====
PR WATER LINE	--- W ---
PR SANITARY SEWER	--- SS ---
PR STORM SEWER	--- SN ---
PR SANITARY SEWER MANHOLE	
PR TYPE R INLET	
PR WATER VALVE	
PR FIRE HYDRANT	

remove vineyard call out

SOUTH FENCE LOCATION

LINE TABLE: ALIGNMENTS

LINE #	LENGTH	START STA	END STA	DIRECTION	START POINT (EAST, NORTH)	END POINT (EAST, NORTH)
L100	352.46	70+00.00	73+52.46	S88° 22' 47.05"W	(3658.89,5290.23)	(3306.57,5280.27)
L101	7.64	73+52.46	73+60.10	N2° 17' 20.96"W	(3306.57,5280.27)	(3306.27,5287.90)
L102	379.90	73+60.10	77+40.00	N5° 10' 54.52"W	(3306.27,5287.90)	(3271.95,5666.25)

V:\52876\active\187608744-Mule Deer\CAD\Sheets\Construction Drawings\17 - PnP Wall.dwg
2019/12/19 11:34 AM By: Pearce, Taylor

Computer File Information	
Creation Date: 4-25-17	Initials: CMD
Last Modification Date:	Initials:
Full Path & Drawing File Name:	
Acad Ver. 2014	Scale: Units: Feet

Index of Revisions	



Stantec Consulting Inc.
5725 MARK DABLING BLVD
Suite 190
Colorado Springs, CO 80919
Tel. (719) 594-4535
Fax.
www.stantec.com

GARDENS AT NORTH CARFREE SOUTH FENCE LOCATION	
Designer: CD	Structure Numbers
Detailer: MB	
Sheet Subset:	

Project No./Code
187608744
SHEET 17 OF 34

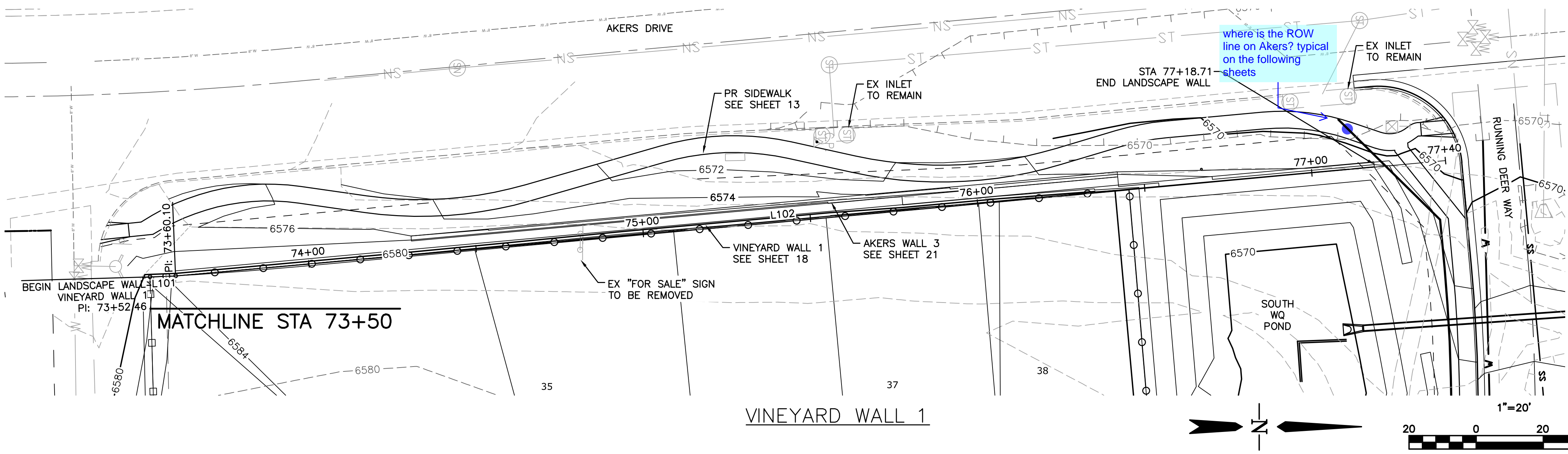

LEGEND

EX MINOR CONTOUR	---
EX MAJOR CONTOUR	---5200---
EX WATER	W
EX SAN SEWER	SN
EX GAS	G
EX STORM SEWER	SN
EX WATER VALVE	WV
EX FIRE HYDRANT	FH
EX SANITARY SEWER MH	SMH
PR MINOR CONTOUR	---
PR MAJOR CONTOUR	---5200---
PR ROW	---
PR WATER LINE	W
PR SANITARY SEWER	SS
PR STORM SEWER	SS
PR SANITARY SEWER MANHOLE	○
PR TYPE R INLET	□
PR WATER VALVE	WV
PR FIRE HYDRANT	FH

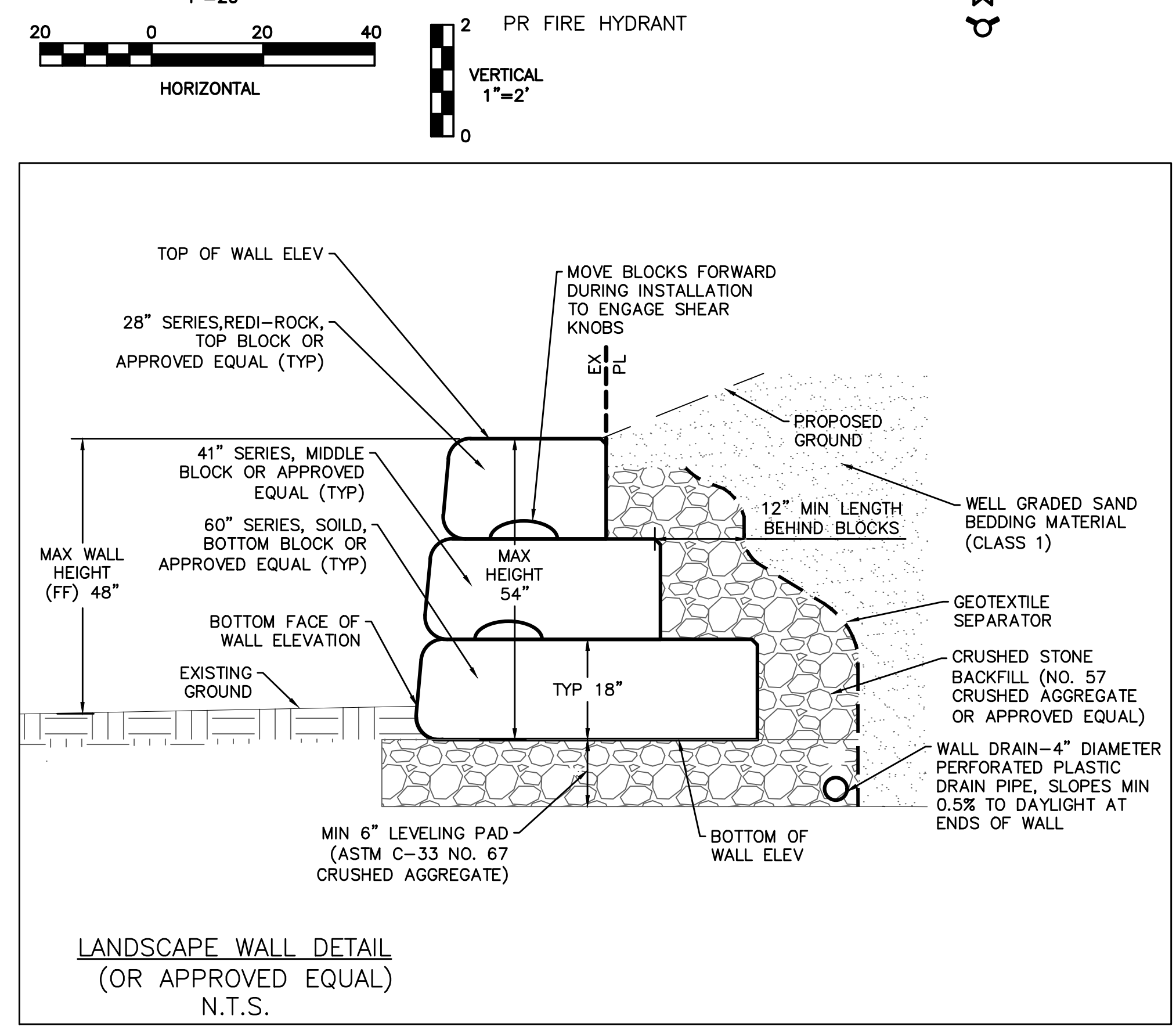
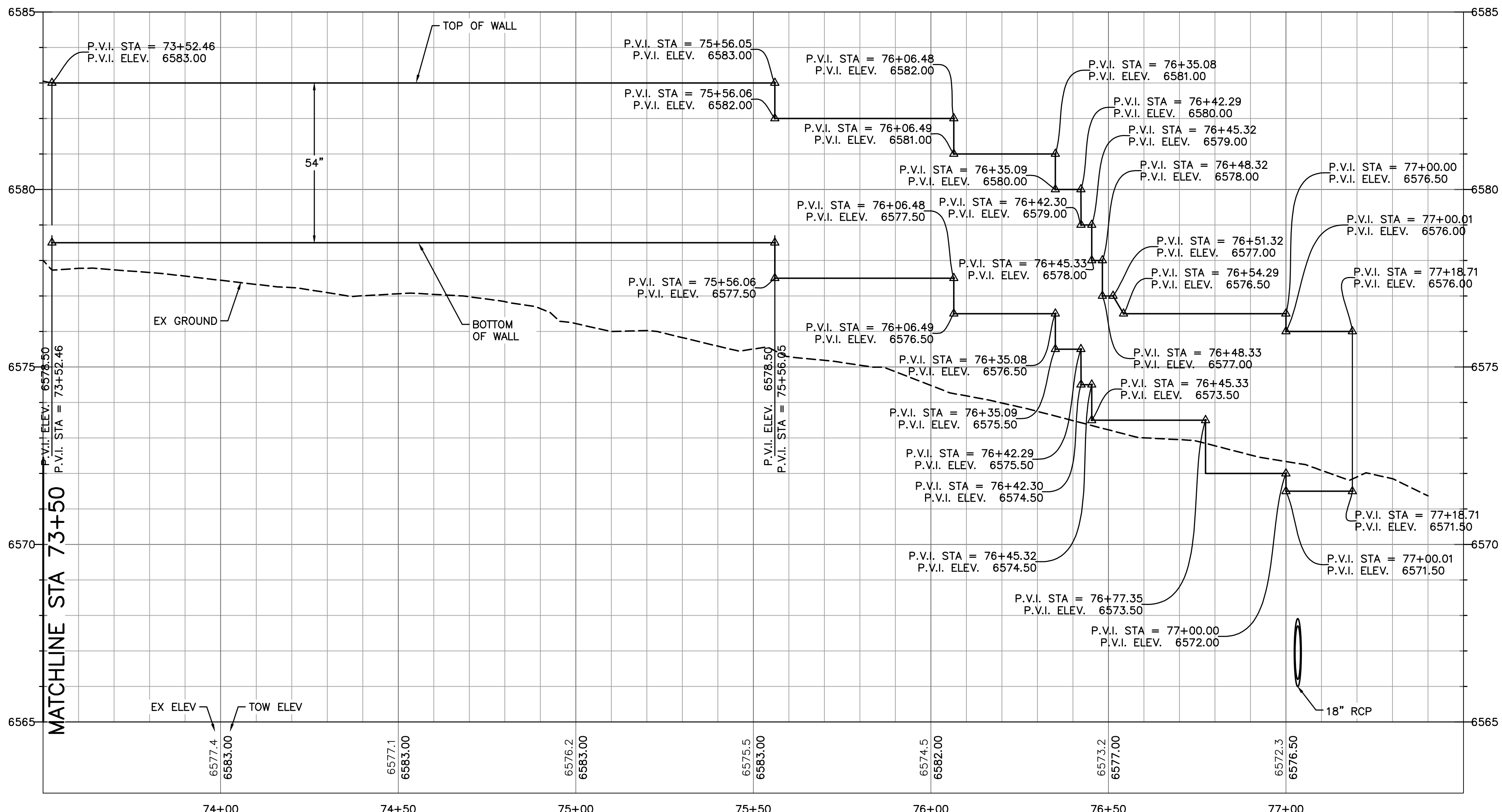

LINE TABLE: ALIGNMENTS

LINE #	LENGTH	START STA	END STA	DIRECTION	START POINT (EAST, NORTH)	END POINT (EAST, NORTH)
L100	352.46	70+00.00	73+52.46	S88° 22' 47.05"W	(3658.89,5290.23)	(3306.57,5280.27)
L101	7.64	73+52.46	73+60.10	N2° 17' 20.96"W	(3306.57,5280.27)	(3306.27,5287.90)
L102	379.90	73+60.10	77+40.00	N5° 10' 54.52"W	(3306.27,5287.90)	(3271.95,5666.25)

V:\52876\active\187608744-Mule Deer\CAD\Sheets\Construction Drawings\17 - PnP Wall.dwg
2019/12/19 11:33 AM By: Pearce, Taylor

Computer File Information

Creation Date: 4-25-17	Initials: CMD	
Last Modification Date:	Initials:	
Full Path & Drawing File Name:		
Acad Ver. 2014	Scale:	Units: Feet

Index of Revisions

**GARDENS AT NORTH CAREFREE
PLAN AND PROFILE
VINEYARD WALL 1 (2 OF 2)**

Designer: CD	Structure Numbers:
Detailer: MB	
Sheet Subset:	

Project No./Code
187608744

SHEET 18 OF 34

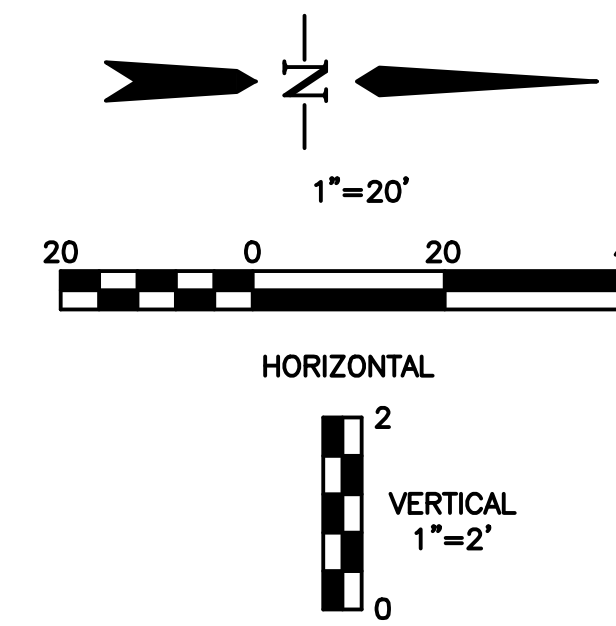
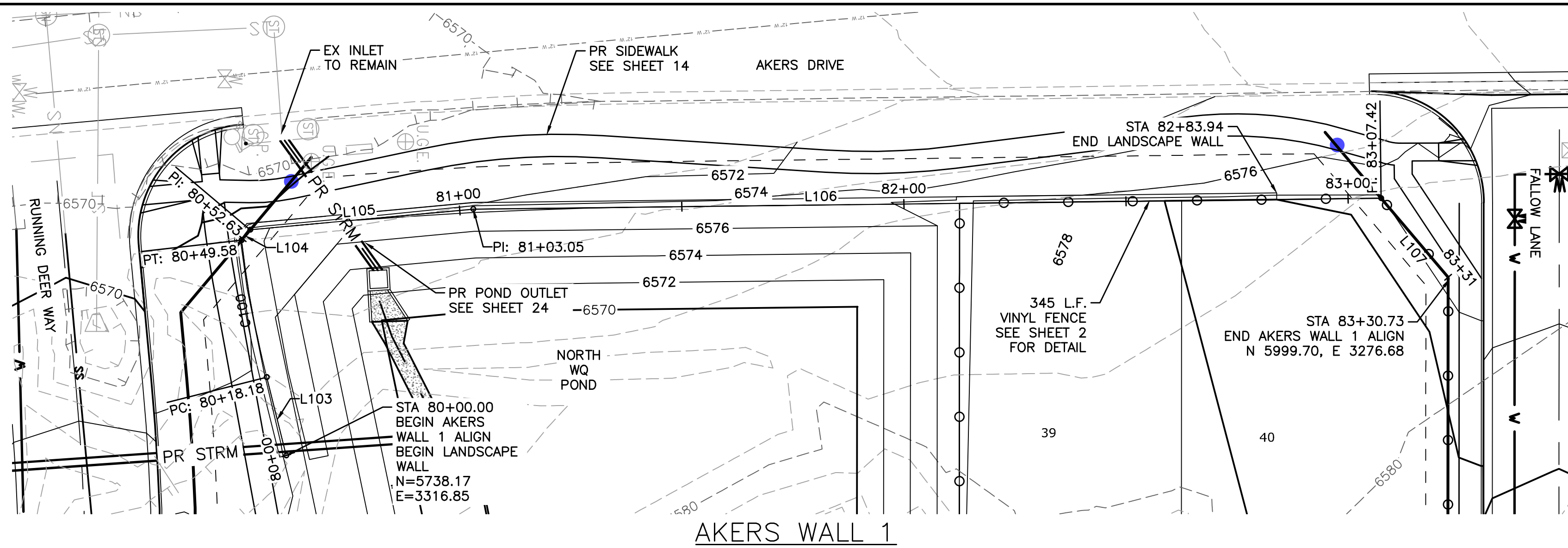

LEGEND

EX MINOR CONTOUR	---
EX MAJOR CONTOUR	---
EX WATER	W
EX SAN SEWER	SN
EX GAS	G
EX STORM SEWER	SS
EX WATER VALVE	WV
EX FIRE HYDRANT	FH
EX SANITARY SEWER MH	SMH
PR MINOR CONTOUR	---
PR MAJOR CONTOUR	---
PR ROW	---
PR WATER LINE	W
PR SANITARY SEWER	SS
PR STORM SEWER	SS
PR SANITARY SEWER MANHOLE	SMH
PR TYPE R INLET	RI
PR WATER VALVE	WV
PR FIRE HYDRANT	FH

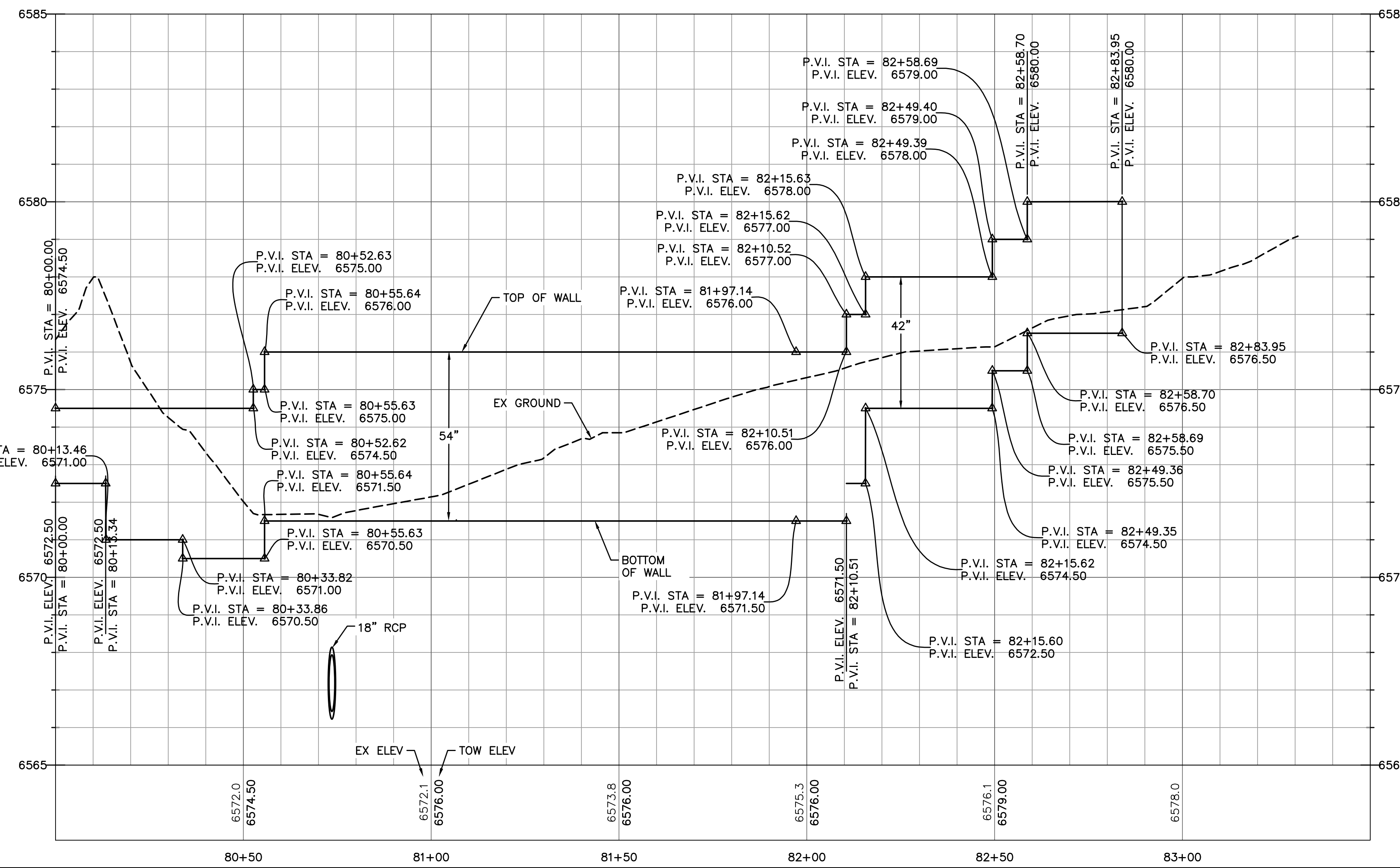

CURVE TABLE: ALIGNMENTS

CURVE #	START STA	END STA	RADIUS	LENGTH	CHORD DIRECTION	DELTA	START POINT (EAST, NORTH)	END POINT (EAST, NORTH)
C100	80+18.18	80+49.58	231.48	31.40	S79° 35' 03.30"W	7.77	(3299.21,5733.76)	(3268.35,5728.08)

LINE TABLE: ALIGNMENTS

LINE #	LENGTH	START STA	END STA	DIRECTION	START POINT (EAST, NORTH)	END POINT (EAST, NORTH)
L103	18.18	80+00.00	80+18.18	S75° 57' 54.80"W	(3316.85,5738.17)	(3299.21,5733.76)
L104	3.05	80+49.58	80+52.63	N49° 54' 31.76"W	(3268.35,5728.08)	(3266.02,5730.05)
L105	50.42	80+52.63	81+03.05	N5° 16' 58.63"W	(3266.02,5730.05)	(3261.37,5780.26)
L106	204.37	81+03.05	83+07.42	N0° 41' 23.42"W	(3261.37,5780.26)	(3258.91,5984.61)
L107	23.31	83+07.42	83+30.73	N49° 39' 52.39"E	(3258.91,5984.61)	(3276.68,5999.70)

V:\52876\active\187608744-Mule Deer\CAD\Sheets\Construction Drawings\17 - PnP Wall.dwg
2019/12/19 11:32 AM By: Pearce, Taylor

Computer File Information

Creation Date: 4-25-17	Initials: CMD
Last Modification Date:	Initials:
Full Path & Drawing File Name:	
Acad Ver. 2014	Scale: Units: Feet

Index of Revisions

Stantec
Stantec Consulting Inc.
5725 MARK DABLING BLVD
Suite 190
Colorado Springs, CO 80919
Tel. (719) 594-4535
Fax.
www.stantec.com

**GARDENS AT NORTH CAREFREE
PLAN AND PROFILE
AKERS WALL 1**

Designer: CD	Structure Numbers
Detailer: MB	
Sheet Subset:	

Project No./Code
187608744
SHEET 19 OF 34

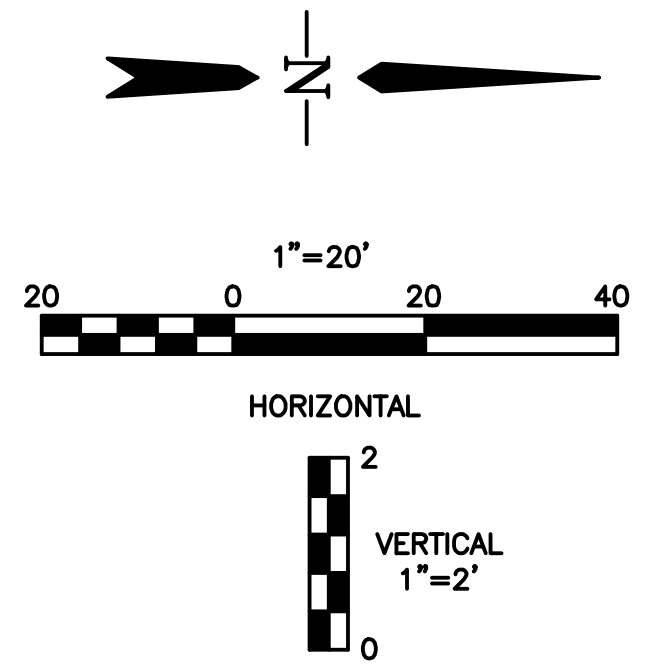
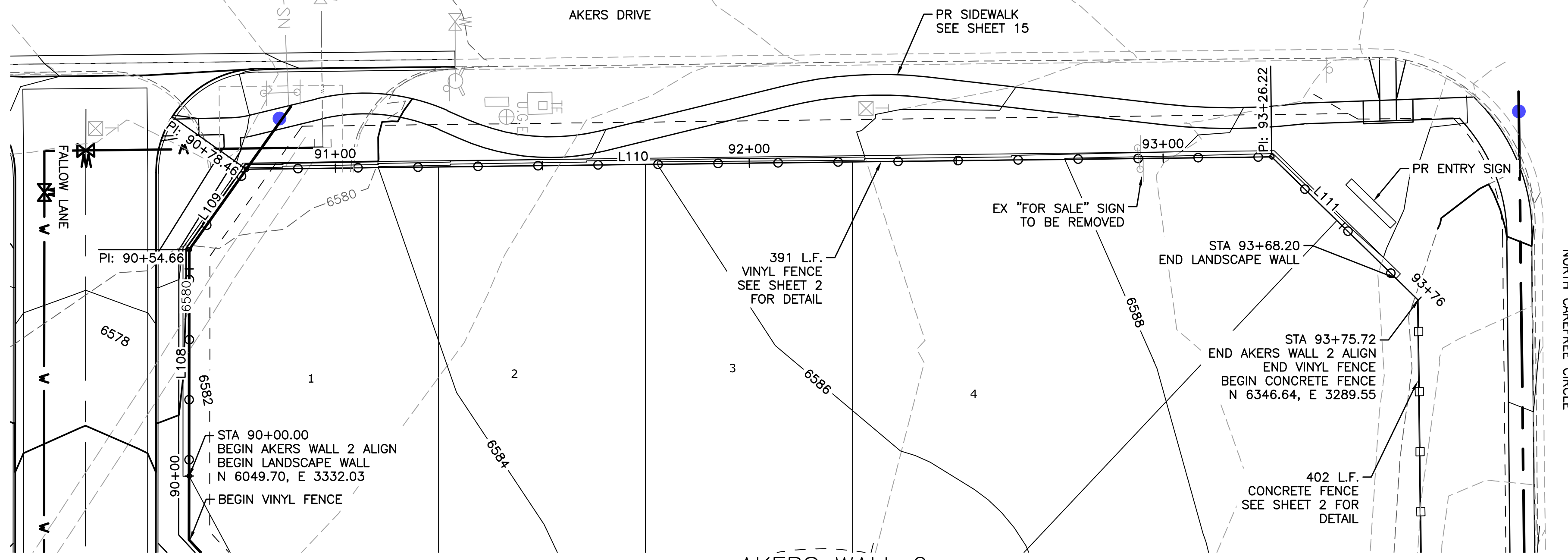

AKERS WALL 2

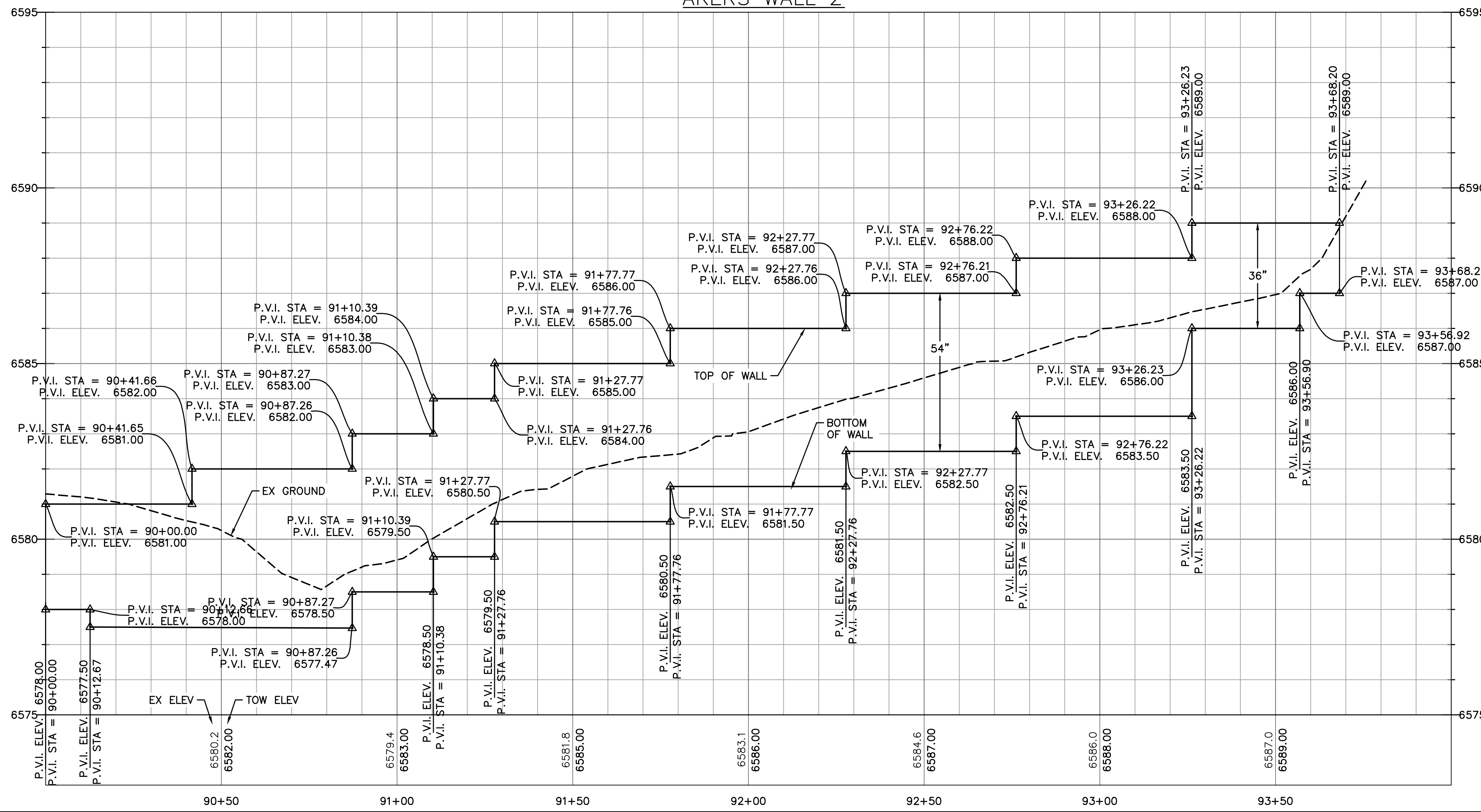

LEGEND

- EX MINOR CONTOUR
- EX MAJOR CONTOUR
- EX WATER
- EX SAN SEWER
- EX GAS
- EX STORM SEWER
- EX WATER VALVE
- EX FIRE HYDRANT
- EX SANITARY SEWER MH
- PR MINOR CONTOUR
- PR MAJOR CONTOUR
- PR ROW
- PR WATER LINE
- PR SANITARY SEWER
- PR STORM SEWER
- PR SANITARY SEWER MANHOLE
- PR TYPE R INLET
- PR WATER VALVE
- PR FIRE HYDRANT

LINE TABLE: ALIGNMENTS

LINE #	LENGTH	START STA	END STA	DIRECTION	START POINT (EAST, NORTH)	END POINT (EAST, NORTH)
L108	54.66	90+00.00	90+54.66	N90° 00' 00.00"W	(3332.03,6049.70)	(3277.37,6049.70)
L109	23.80	90+54.66	90+78.46	N54° 37' 20.50"W	(3277.37,6049.70)	(3257.96,6063.48)
L110	247.76	90+78.46	93+26.22	N0° 41' 23.42"W	(3257.96,6063.48)	(3254.98,6311.22)
L111	49.49	93+26.22	93+75.72	N44° 18' 30.21"E	(3254.98,6311.22)	(3289.55,6346.64)

V:\52876\active\187608744-Mule Deer\CAD\Sheets\Construction Drawings\17 - PrP Wall.dwg
2019/12/19 11:30 AM By: Pearce, Taylor

Computer File Information	
Creation Date: 4-25-17	Initials: CMD
Last Modification Date:	Initials:
Full Path & Drawing File Name:	
Acad Ver. 2014	Scale: Units: Feet

Index of Revisions	

Stantec Consulting Inc.
5725 MARK DABLING BLVD
Suite 190
Colorado Springs, CO 80919
Tel. (719) 594-4535
Fax.
www.stantec.com

GARDENS AT NORTH CAREFREE PLAN AND PROFILE AKERS WALL 2		
Designer: CD	Structure Numbers	
Detailer: MB		
Sheet Subset:		

Project No./Code
187608744
SHEET 20 OF 34

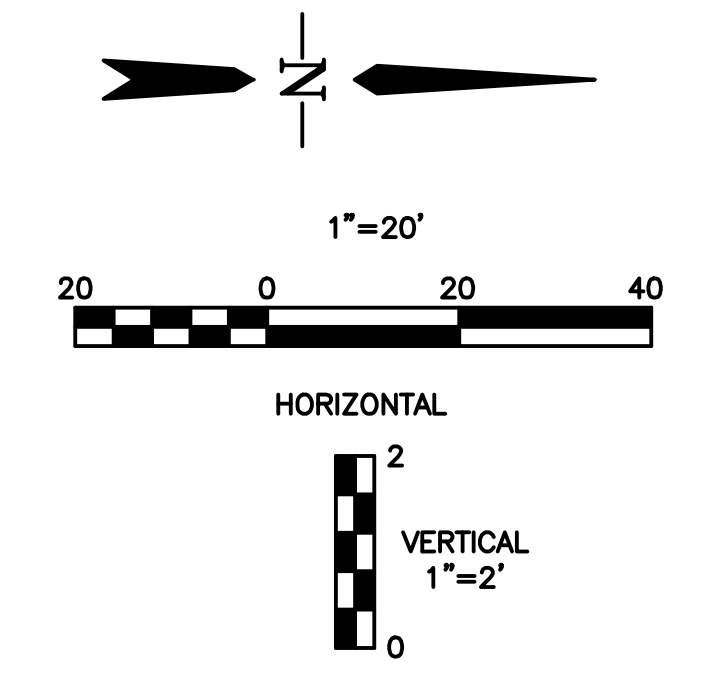
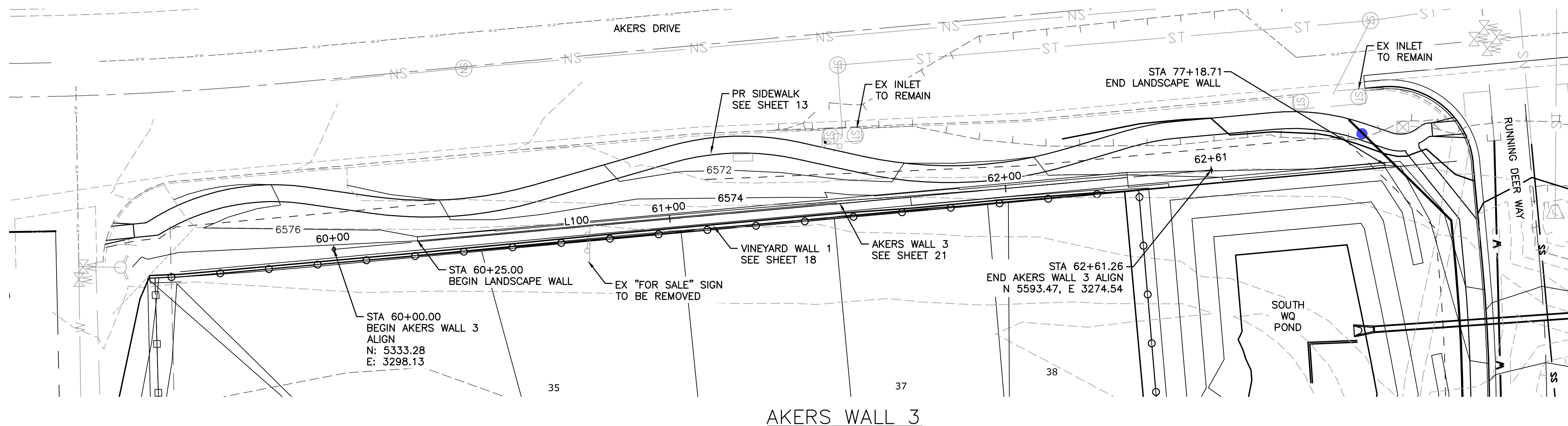

LEGEND

EX MINOR CONTOUR	---
EX MAJOR CONTOUR	----- 5200
EX WATER	---
EX SAN SEWER	---
EX GAS	---
EX STORM SEWER	---
EX WATER VALVE	⊕
EX FIRE HYDRANT	⊕
EX SANITARY SEWER MH	⊕
PR MINOR CONTOUR	---
PR MAJOR CONTOUR	----- 5200
PR ROW	---
PR WATER LINE	W
PR SANITARY SEWER	SS
PR STORM SEWER	---
PR SANITARY SEWER MANHOLE	⊕
PR TYPE R INLET	⊕
PR WATER VALVE	⊕
PR FIRE HYDRANT	⊕

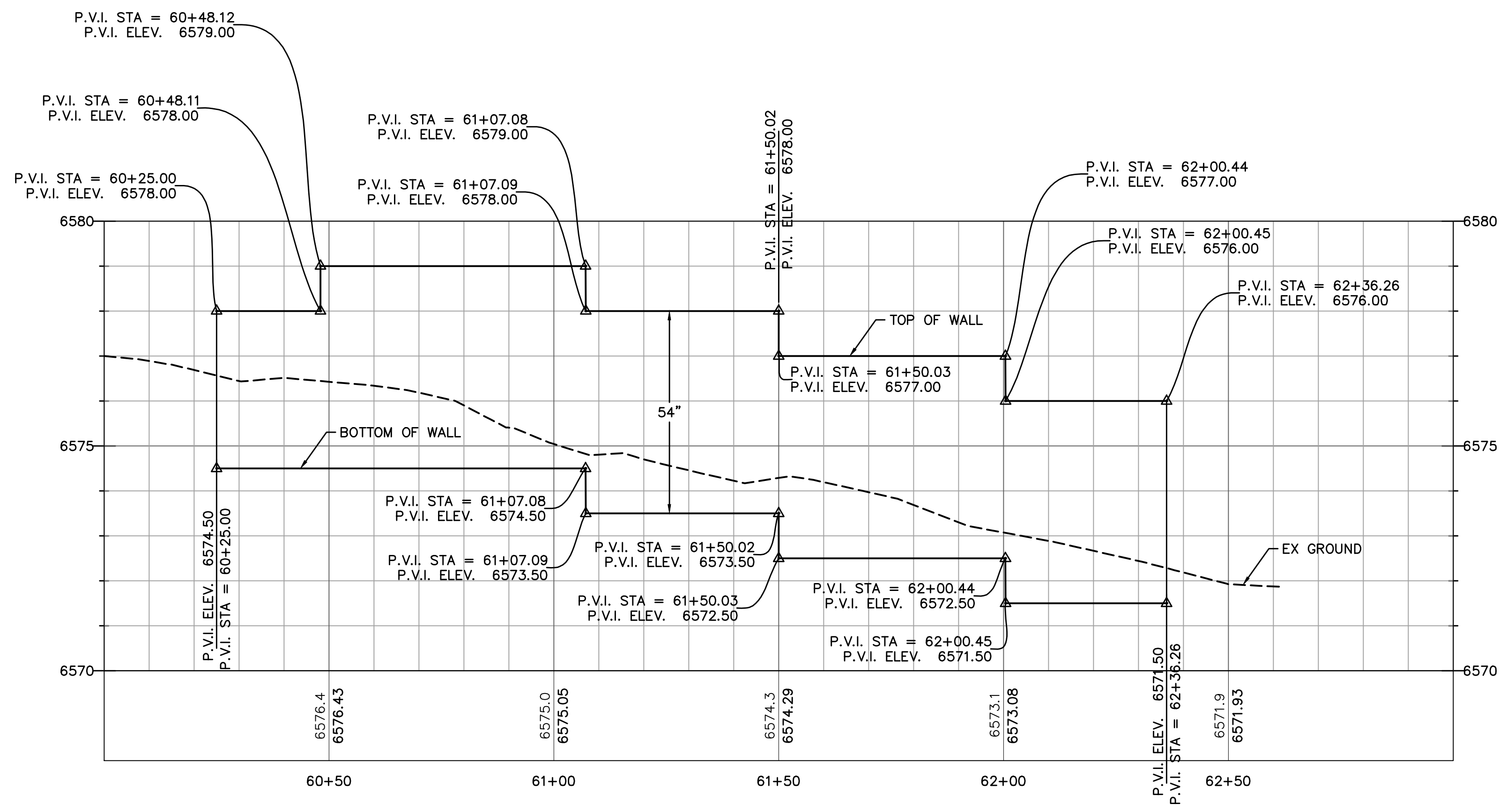

LINE TABLE: ALIGNMENTS

LINE #	LENGTH	START STA	END STA	DIRECTION	START POINT (EAST, NORTH)	END POINT (EAST, NORTH)
L100	261.26	60+00.00	62+61.26	N5° 10' 52.89"W	(3298.13, 5333.28)	(3274.54, 5593.47)

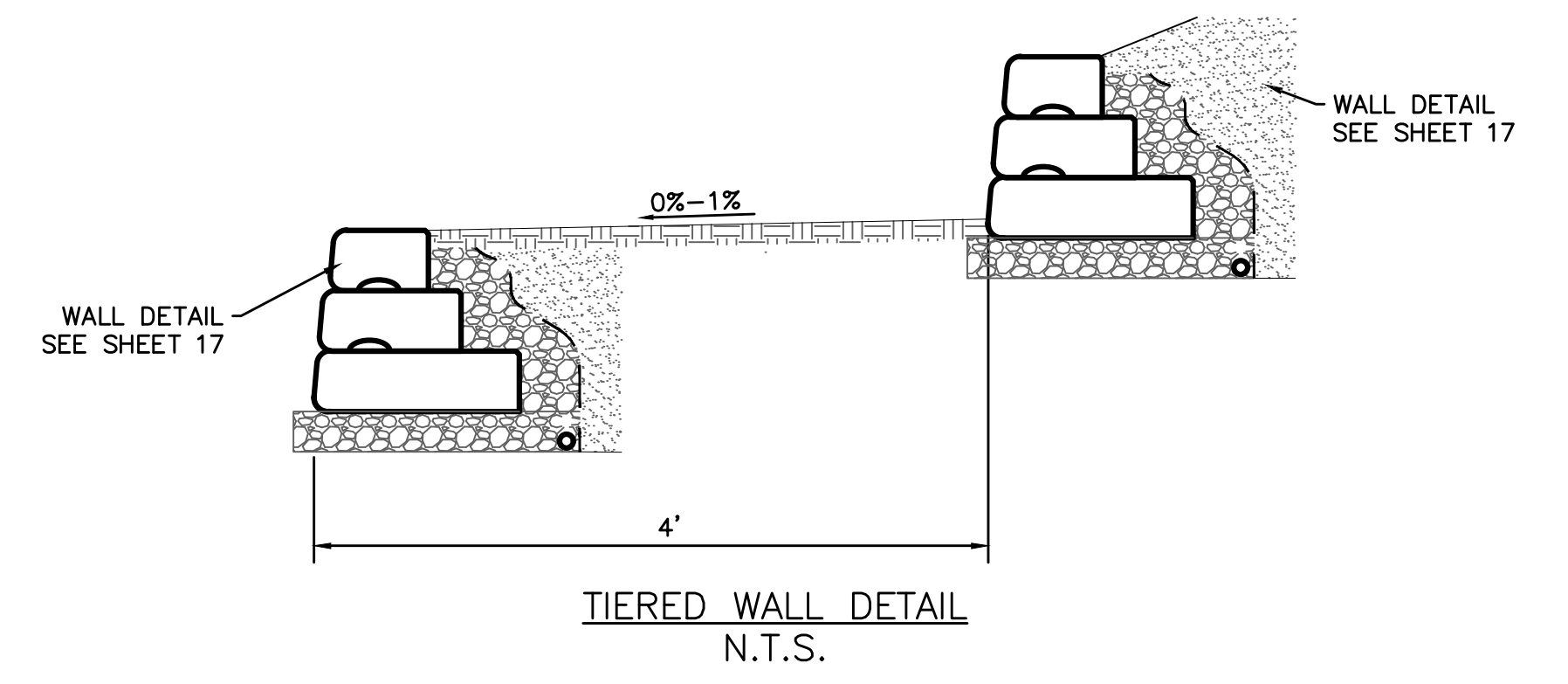

V:\52876\active\187608744-Mule Deer\CAD\Sheets\Construction Drawings\17 - PnP Wall.dwg
2019/12/19 11:32 AM By: Pearce, Taylor

Computer File Information

Creation Date: 4-25-17	Initials: CMD	
Last Modification Date:	Initials:	
Full Path & Drawing File Name:		
Acad Ver. 2014	Scale:	Units: Feet

Index of Revisions

Stantec
Stantec Consulting Inc.
5725 MARK DABLING BLVD
Suite 190
Colorado Springs, CO 80919
Tel. (719) 594-4535
Fax:
www.stantec.com

**GARDENS AT NORTH CAREFREE
PLAN AND PROFILE
AKERS WALL 3**

Designer: CD	Structure Numbers:
Detailer: MB	
Sheet Subset:	

Project No./Code
187608744

SHEET 21 OF 34

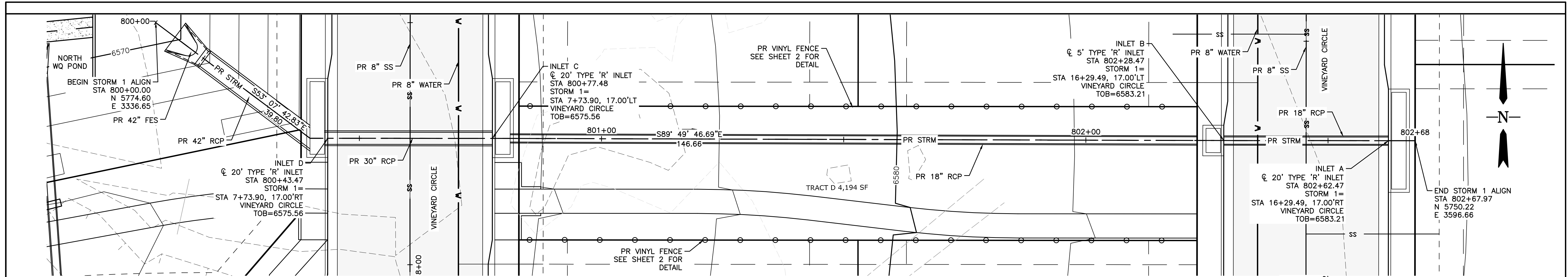

STORM SYSTEM 1

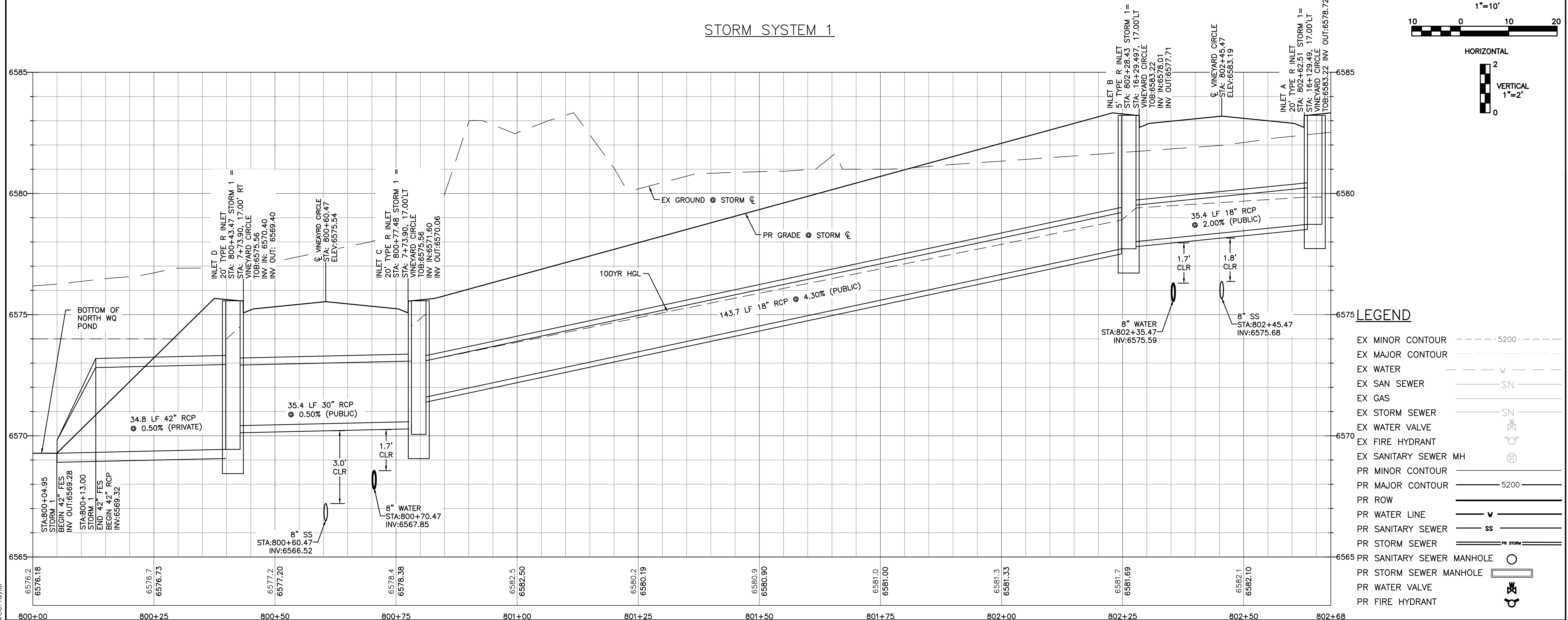
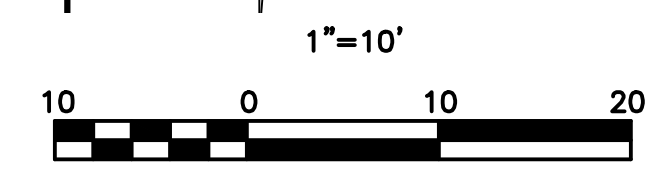

LEGEND

EX MINOR CONTOUR	---	5200
EX MAJOR CONTOUR	---	
EX WATER	---	W
EX SAN SEWER	---	SN
EX GAS	---	
EX STORM SEWER	---	SN
EX WATER VALVE	---	WV
EX FIRE HYDRANT	---	FH
EX SANITARY SEWER MH	---	SMH
PR MINOR CONTOUR	---	
PR MAJOR CONTOUR	---	5200
PR ROW	---	
PR WATER LINE	---	W
PR SANITARY SEWER	---	SS
PR STORM SEWER	---	PR STORM
PR SANITARY SEWER MANHOLE	---	○
PR STORM SEWER MANHOLE	---	□
PR WATER VALVE	---	WV
PR FIRE HYDRANT	---	FH

V:\52876\active\187608744-Mule Deer\CAD\Sheets\Construction Drawings\21 - Storm.dwg
2019/12/19 1:19 PM By: Pearce, Taylor

Computer File Information

Creation Date: 4-25-17	Initials: CMD
Last Modification Date:	Initials:
Full Path & Drawing File Name:	
Acad Ver. 2014	Scale: Units: Feet

Index of Revisions

0000			
0000			
0000			
0000			

Stantec
Stantec Consulting Inc.
5725 MARK DABLING BLVD
Suite 190
Colorado Springs, CO 80919
Tel. (719) 594-4535
Fax.
www.stantec.com

**GARDENS AT NORTH CAREFREE
PLAN AND PROFILE
STORM SEWER 1**

Designer: CD	Structure Numbers
Detailer: MB	
Sheet Subset:	

Project No./Code
187608744

SHEET 22 OF 34

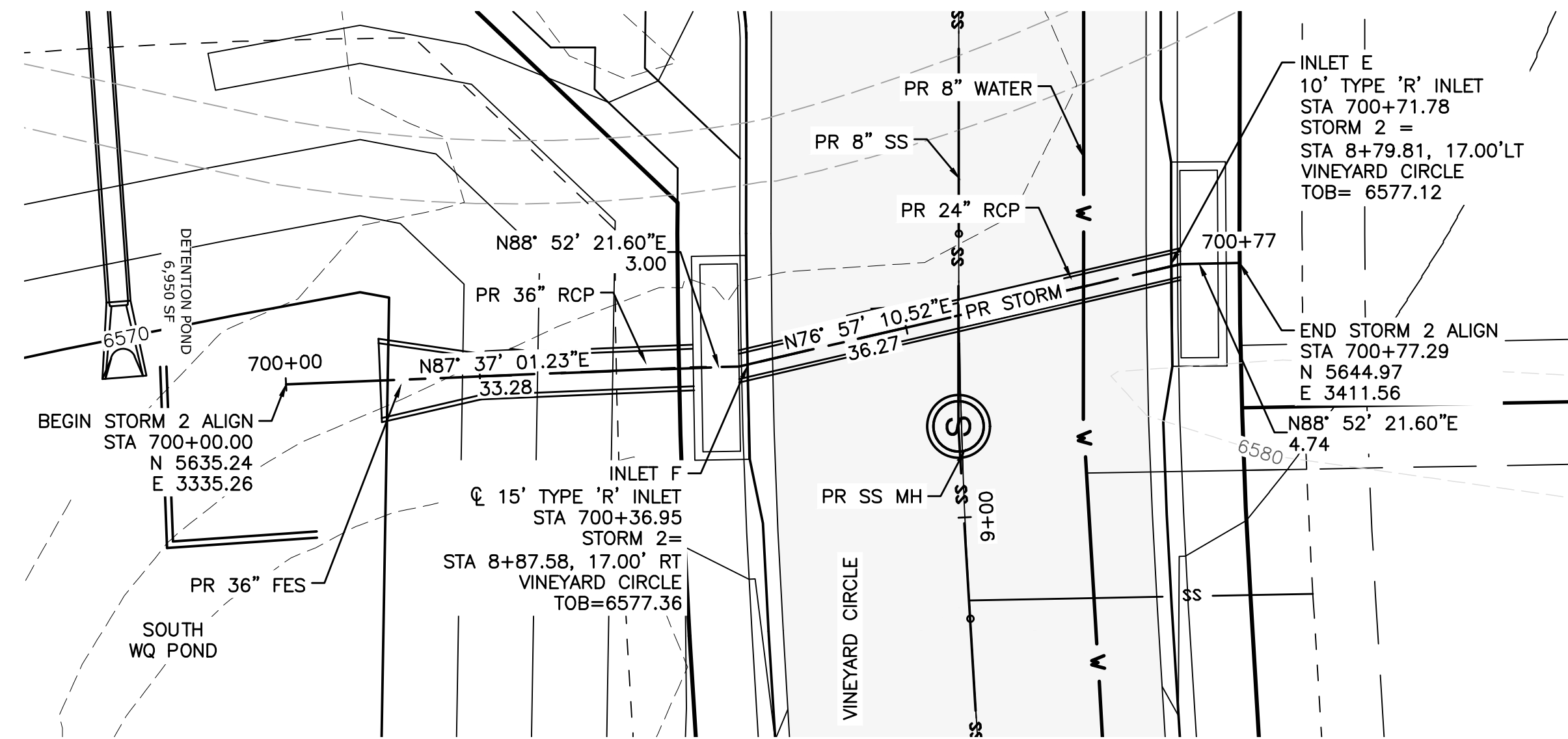

STORM SYSTEM 2

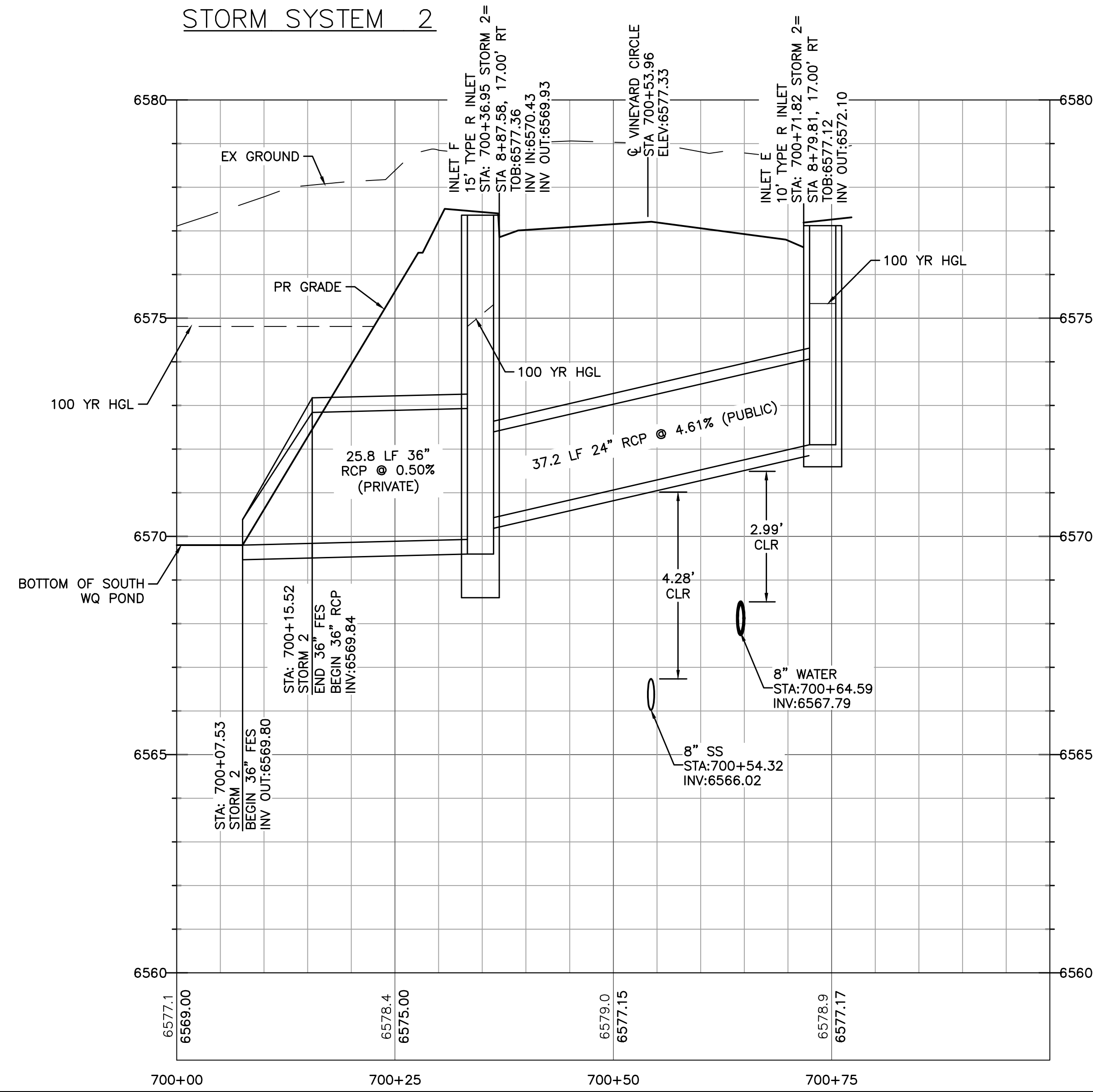

LEGEND

EX MINOR CONTOUR	---
EX MAJOR CONTOUR	----- 5200 -----
EX WATER	---
EX SAN SEWER	---
EX GAS	---
EX STORM SEWER	---
EX WATER VALVE	⊕
EX FIRE HYDRANT	⊕
EX SANITARY SEWER MH	⊕
PR MINOR CONTOUR	---
PR MAJOR CONTOUR	----- 5200 -----
PR ROW	=====
PR WATER LINE	— v —
PR SANITARY SEWER	— ss —
PR STORM SEWER	— PR STORM —
PR SANITARY SEWER MANHOLE	⊕
PR TYPE R INLET	⊕
PR WATER VALVE	⊕
PR FIRE HYDRANT	⊕

V:\52876\active\187608744-Mule Deer\CAD\Sheets\Construction Drawings\21 - Storm.dwg
2019/12/19 11:48 AM By: Pearce, Taylor

Computer File Information	
Creation Date: 4-25-17	Initials: CMD
Last Modification Date:	Initials:
Full Path & Drawing File Name:	
Acad Ver. 2014	Scale: Units: Feet

Index of Revisions	
0000	
0000	
0000	
0000	

Stantec Consulting Inc.
5725 MARK DABLING BLVD
Suite 190
Colorado Springs, CO 80919
Tel. (719) 594-4535
Fax.
www.stantec.com

GARDENS AT NORTH CAREFREE PLAN AND PROFILE STORM SEWER 2	
Designer: CD	Structure Numbers
Detailer: MB	
Sheet Subset:	

Project No./Code	187608744
SHEET 23 OF 34	

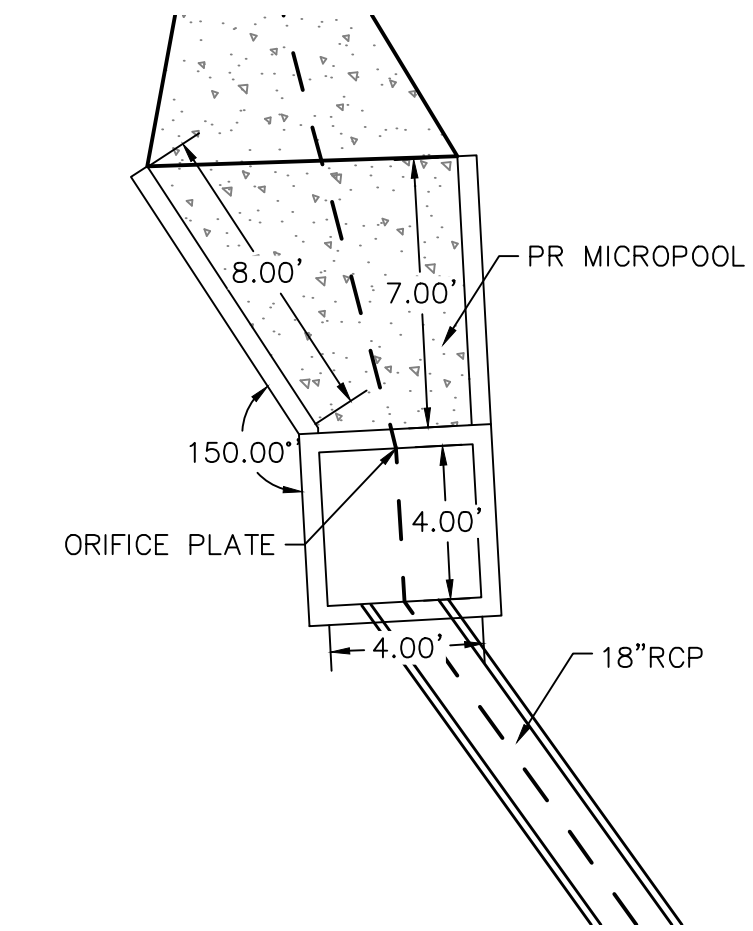
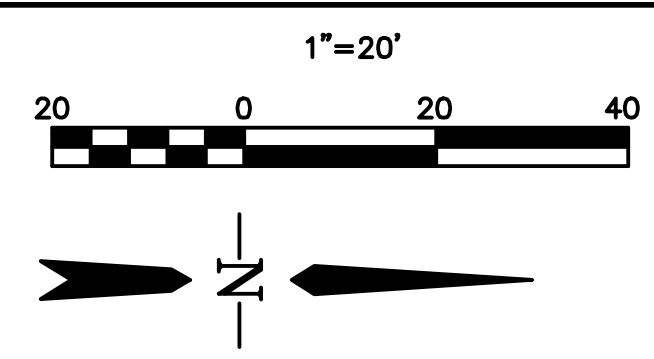
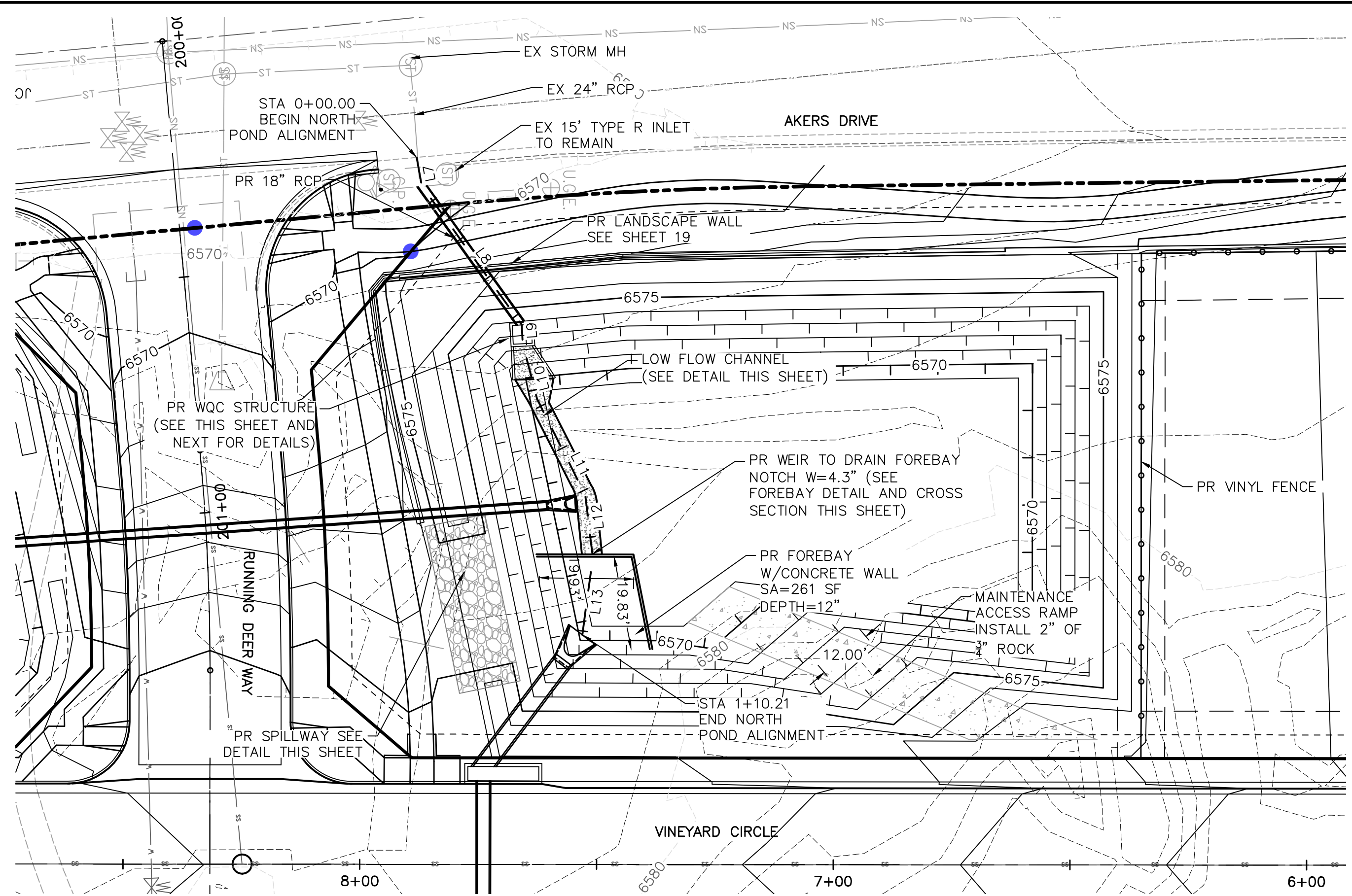

- WQCV TRASH RACKS:**
1. WELL-SCREEN TRASH RACKS SHALL BE STAINLESS STEEL AND SHALL BE ATTACHED BY INTERMITTENT WELDS ALONG THE EDGE OF THE MOUNTAIN FRAME.
 2. BAR GATE TRASH RACKS SHALL BE ALUMINUM AND SHALL BE BOLTED USING STAINLESS STEEL HARDWARE.
 3. TRASH RACK WIDTHS ARE FOR SPECIFIED TRASH RACK MATERIAL. FINER WELL-SCREEN OR MESH SIZE THAN SPECIFIED IS ACCEPTABLE, HOWEVER, TRASH RACK DIMENSIONS NEED TO BE ADJUSTED FOR MATERIALS HAVING A DIFFERENT OPEN AREA/GROSS AREA RATION (R VALUE).

- OVERFLOW TRASH RACKS:**
1. ALL TRASH RACKS SHALL BE MOUNTED USING STAINLESS STEEL HARDWARE AND BE PROVIDED WITH HINGED AND BOLTABLE ACCESS PANELS.
 2. TRASH RACKS SHALL BE STAINLESS STEEL, ALUMINUM, OR STEEL. STEEL TRASH RACKS SHALL BE HOT DIP GALVANIZED AND MAY BE HOT POWDER PAINTED AFTER GALVANIZING.

- ORIFICE PLATES:**
1. STEEL ORIFICE PLATES SHALL BE HOT DIP GALVANIZED AND MAY BE HOT POWDER PAINTED AFTER GALVANIZING.

- STANDARD INLET GRATE:**
1. STRUCTURAL STEEL FOR GRATES & GRATE INSTALLATION HARDWARE SHALL BE GALVANIZED & SHALL BE IN ACCORDANCE WITH 712.06.

- GENERAL NOTES:**
1. STEPS SHALL BE PROVIDED WHEN DIMENSION "H" EXCEEDS 3-FT-6 IN. AND SHALL BE IN ACCORDANCE WITH AASHTO M 199.

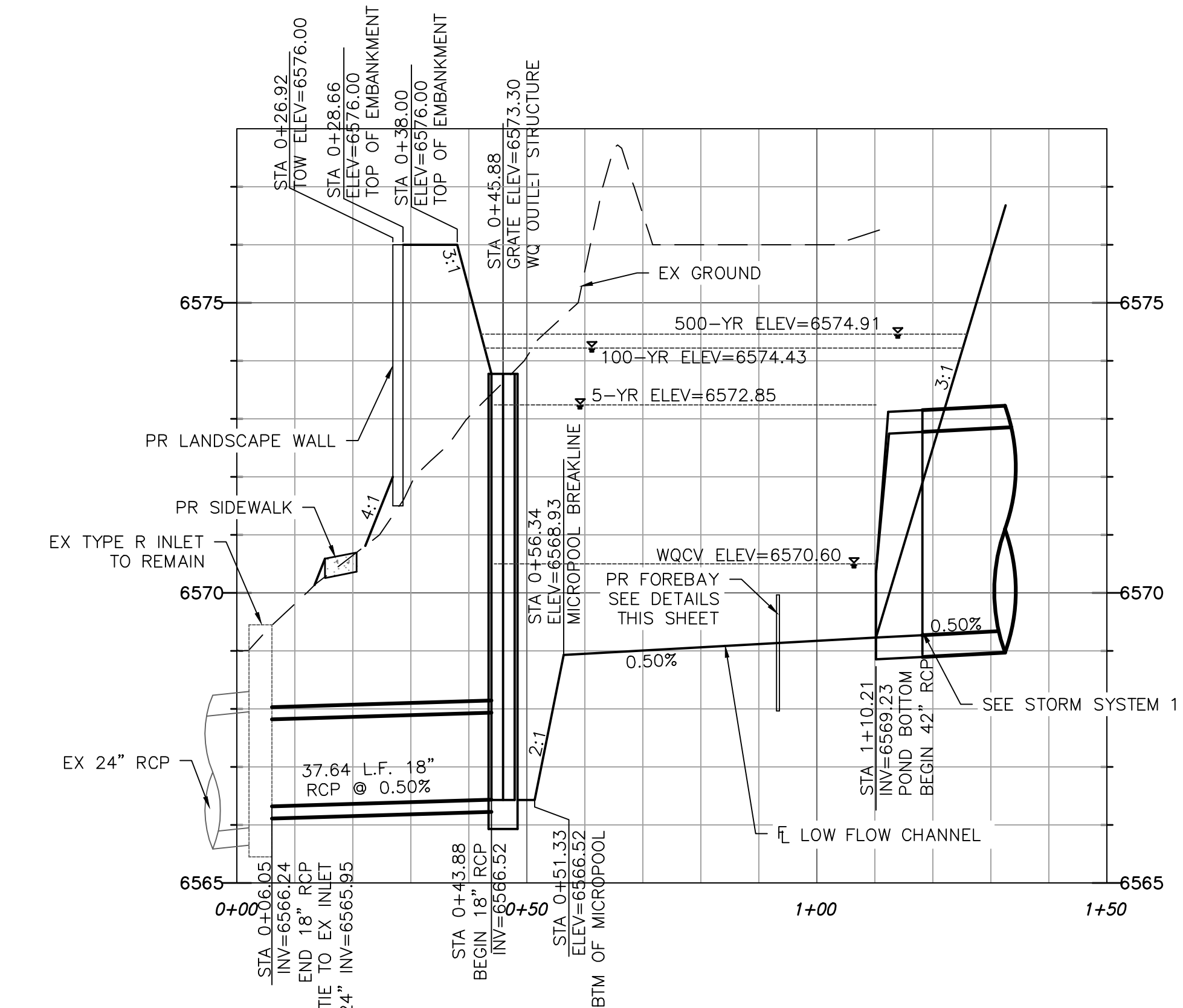
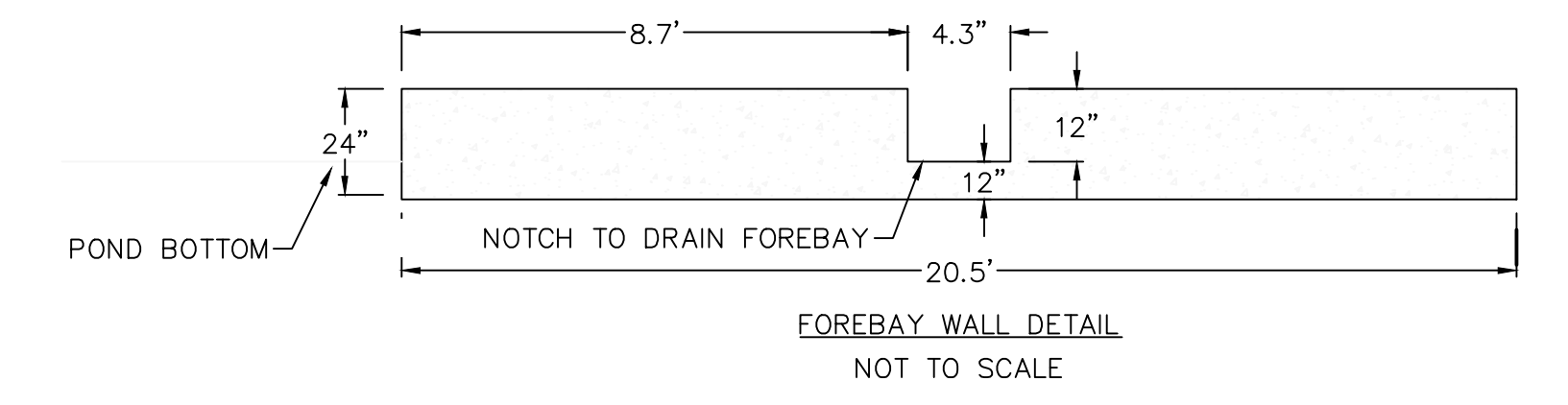

LINE TABLE: ALIGNMENTS						
LINE #	LENGTH	START STA	END STA	DIRECTION	START POINT (EAST, NORTH)	END POINT (EAST, NORTH)
L7	6.05	0+00.00	0+06.05	N79° 42' 46.45"E	(3239.78,5736.61)	(3245.73,5737.69)
L8	36.23	0+06.05	0+42.28	N54° 19' 54.69"E	(3245.73,5737.69)	(3275.16,5758.81)
L9	4.00	0+42.28	0+46.28	N86° 53' 02.73"E	(3275.16,5758.81)	(3279.16,5759.03)
L10	12.05	0+46.28	0+58.33	N75° 25' 25.98"E	(3279.16,5759.03)	(3290.82,5762.06)
L11	22.49	0+58.33	0+80.82	N63° 16' 09.27"E	(3290.82,5762.06)	(3310.91,5772.18)
L12	13.35	0+80.82	0+94.17	N82° 51' 22.50"E	(3310.91,5772.18)	(3324.15,5773.84)
L13	16.65	0+94.17	1+10.82	S82° 16' 52.95"E	(3324.15,5773.84)	(3340.65,5771.60)

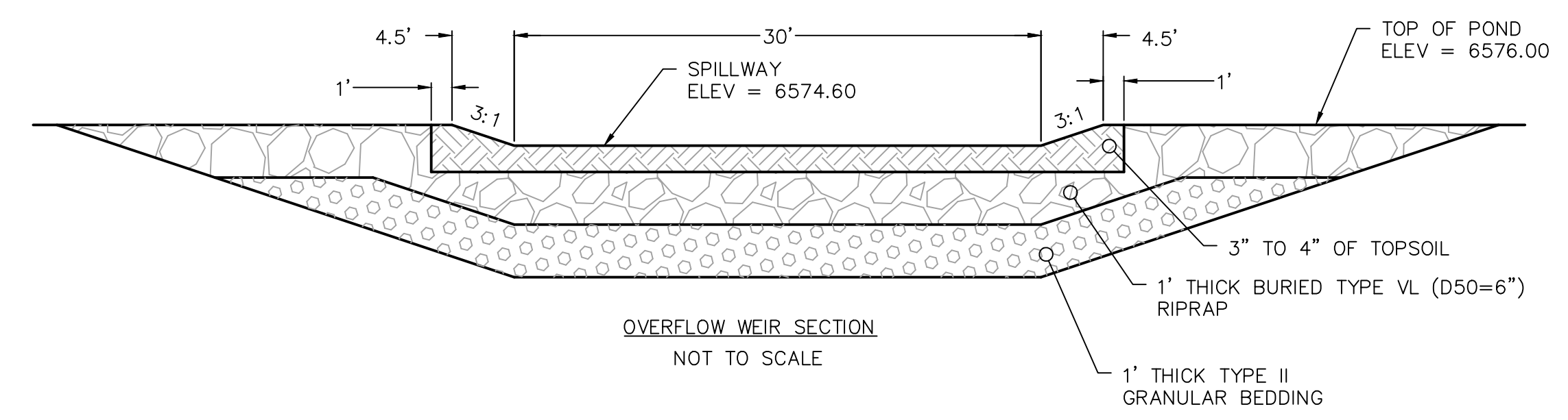
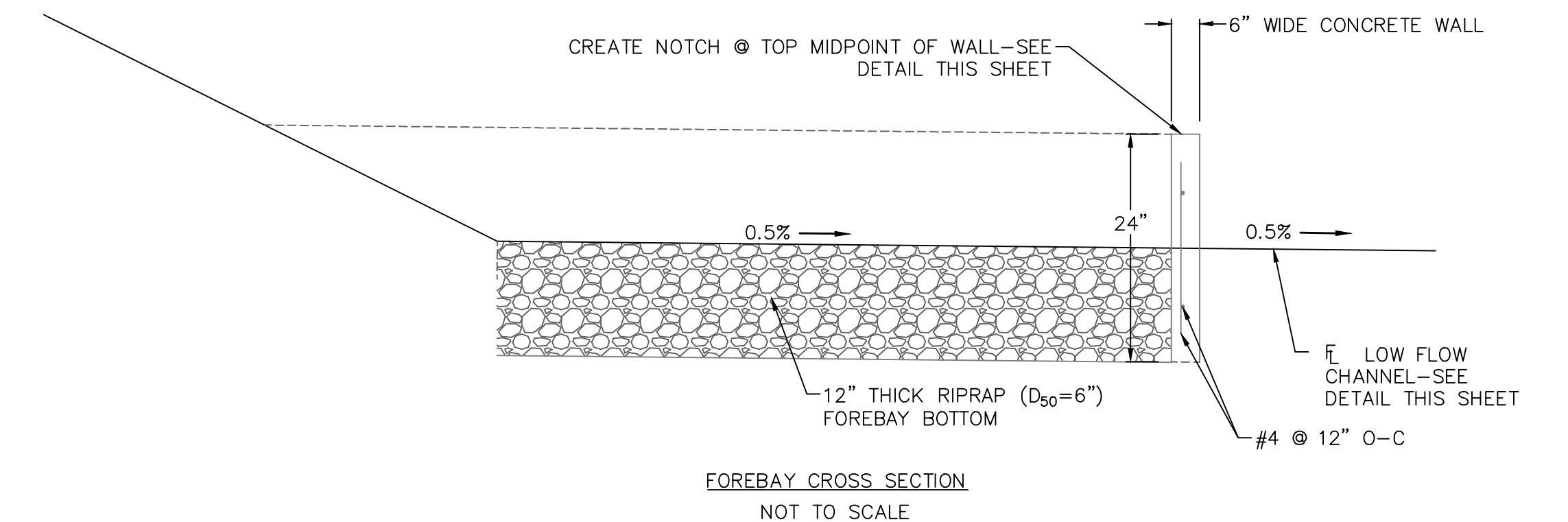
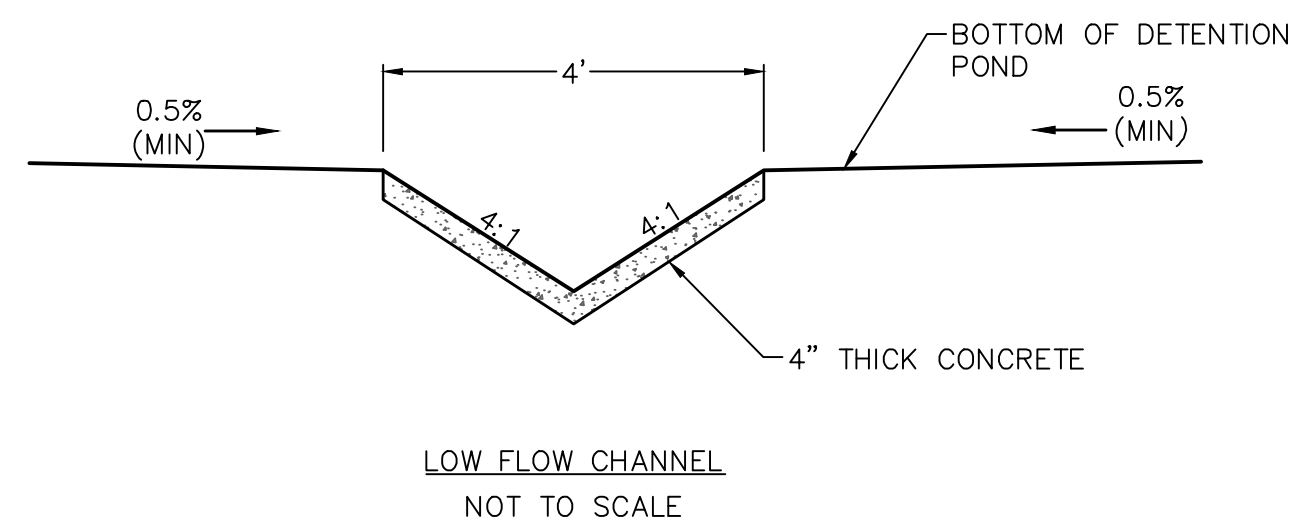

V:\52876\active\187608744-Mule Deer\CAD\Sheets\Construction Drawings\23 - North Pond.dwg
2019/12/12 12:47 PM By: Pearce, Taylor

Computer File Information	
Creation Date: 4-25-17	Initials: CMD
Last Modification Date:	Initials:
Full Path & Drawing File Name:	
Acad Ver. 2014	Scale: Units: Feet

Index of Revisions	
0000	
0000	
0000	

Stantec
Stantec Consulting Inc.
5725 MARK DABLING BLVD
Suite 190
Colorado Springs, CO 80919
Tel. (719) 594-4535
Fax.
www.stantec.com

GARDENS AT NORTH CAREFREE NORTH WQ POND	
Designer: CD	Structure Numbers
Detailer: MB	
Sheet Subset:	

Project No./Code
187608744
SHEET 24 OF 34

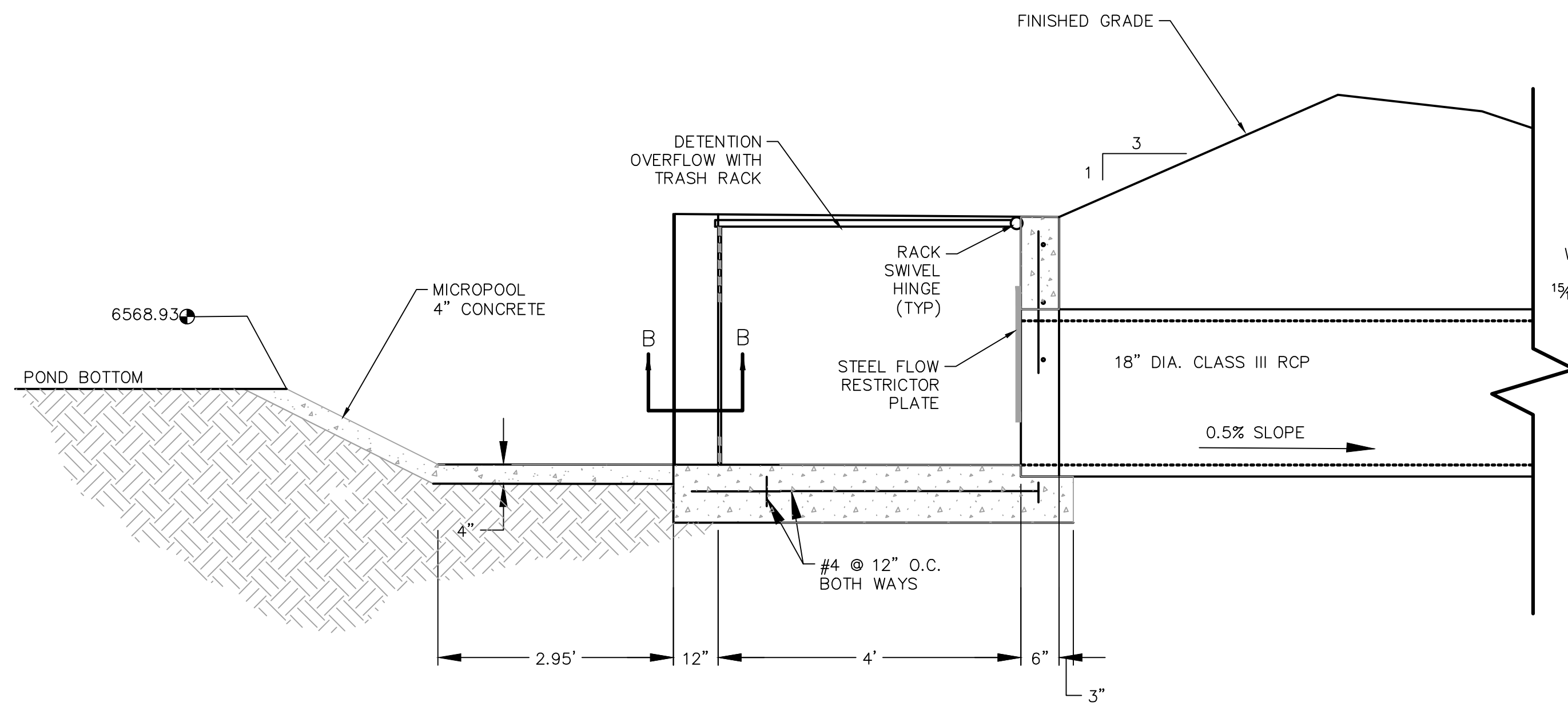

DETENTION BASIN OUTLET STRUCTURE

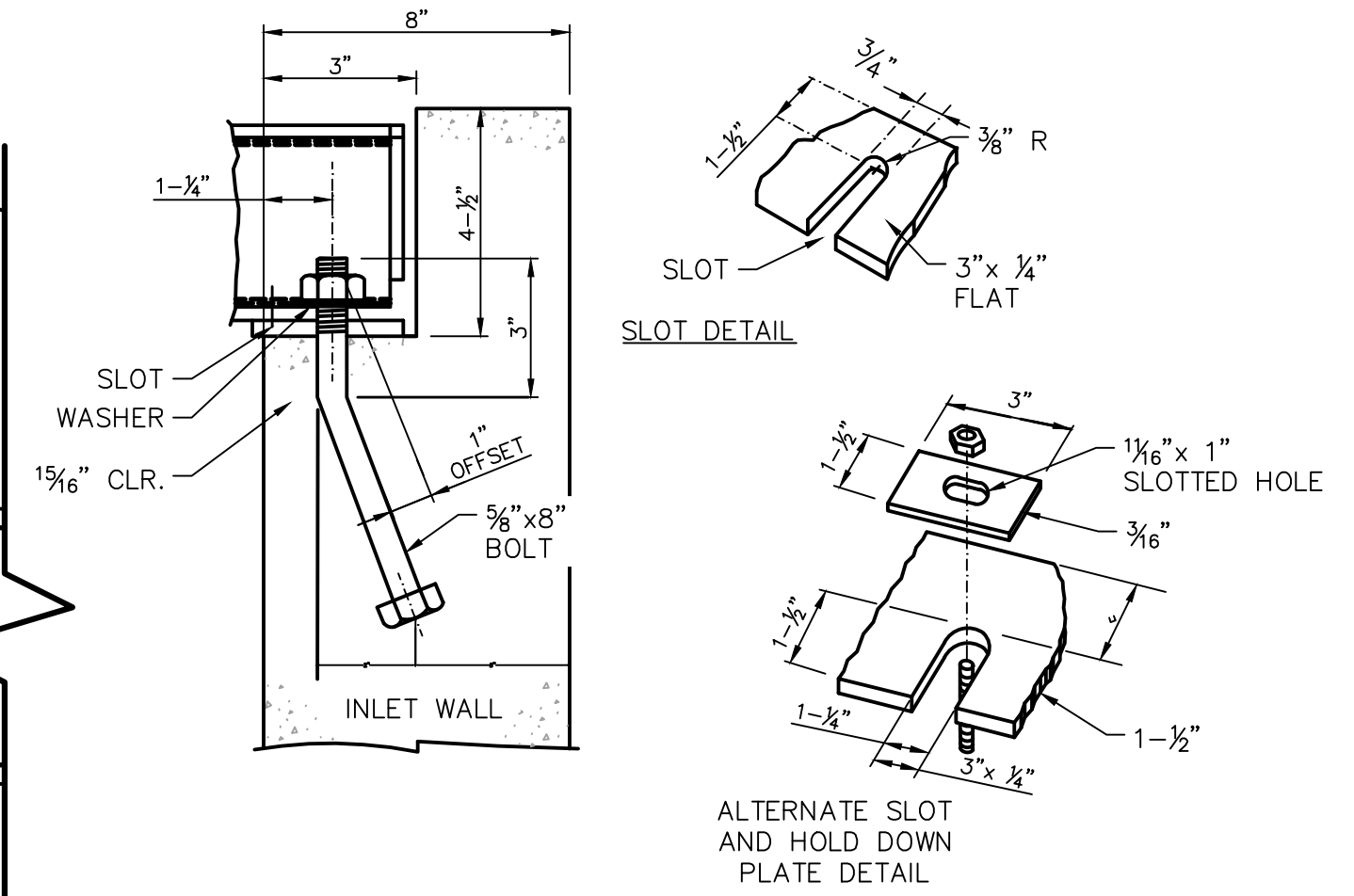

GRATE INSTALLATION DETAIL
NOT TO SCALE

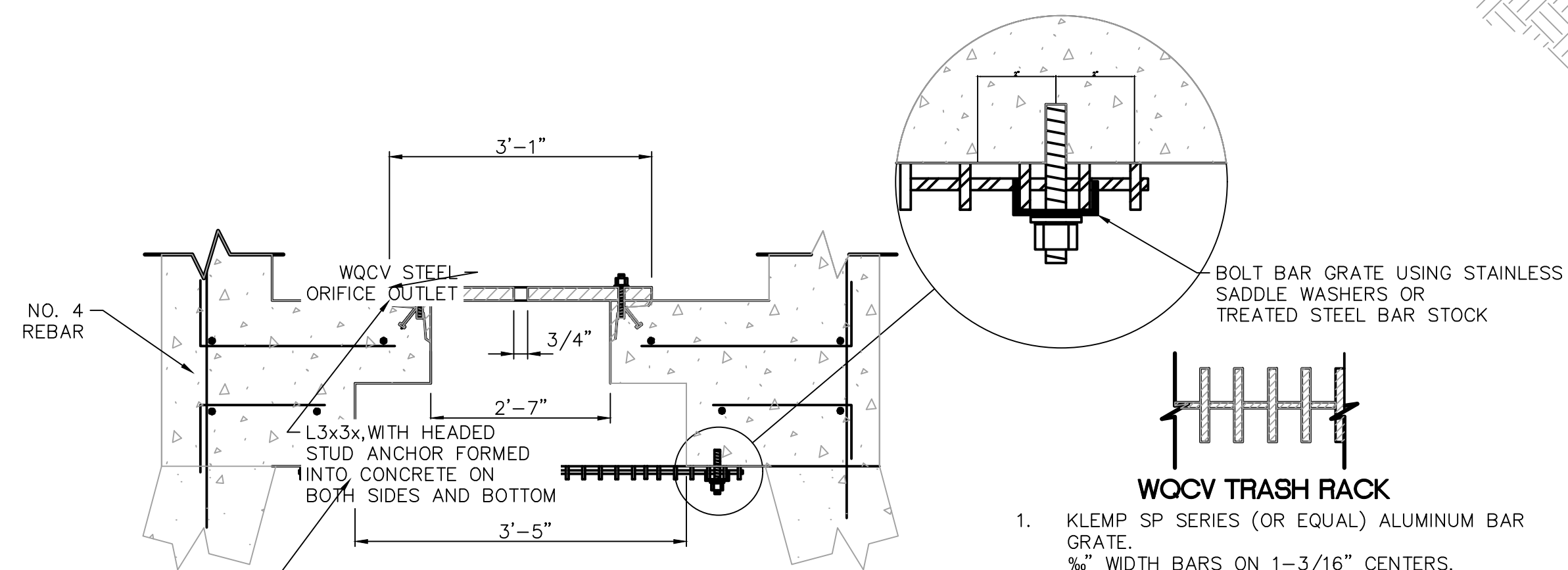

WQCV TRASH RACK AND ORIFICE PLATE SECTION B-B

- WQCV TRASH RACK**
1. KLEMP SP SERIES (OR EQUAL) ALUMINUM BAR GRATE. 3/8" WIDTH BARS ON 1-3/16" CENTERS.
 2. R VALUE = (NET OPEN AREA)/(GROSS RACK AREA) = 0.71 FOR CROSS RODS ON 2" CENTERS.
 3. KLEMP CORPORATION, OREM, UTAH, USA.

NOTES:
REINFORCING BARS SHALL HAVE A 2 INCH MINIMUM CLEARANCE.

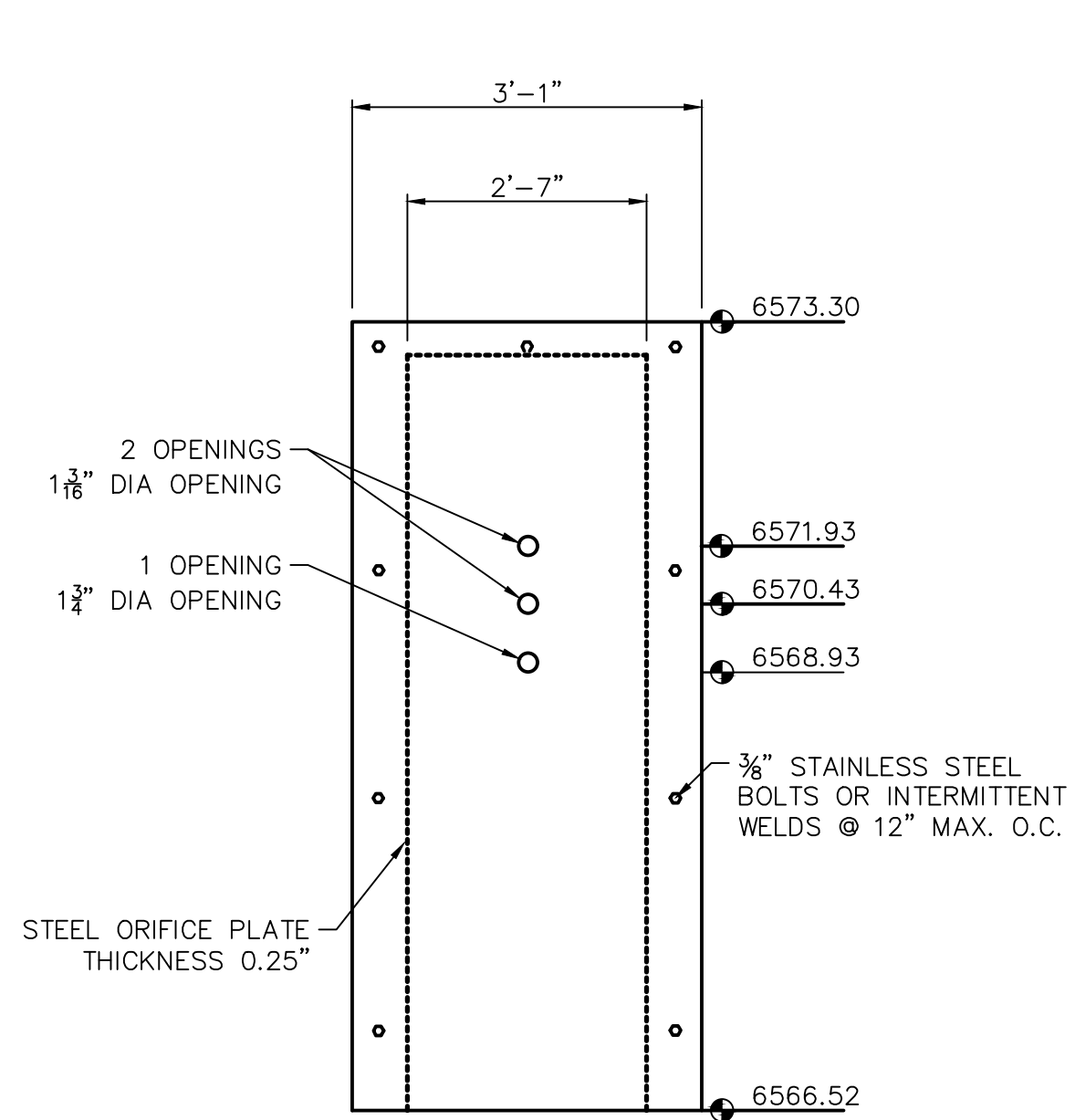

WQCV ORIFICE PLATE
NOT TO SCALE

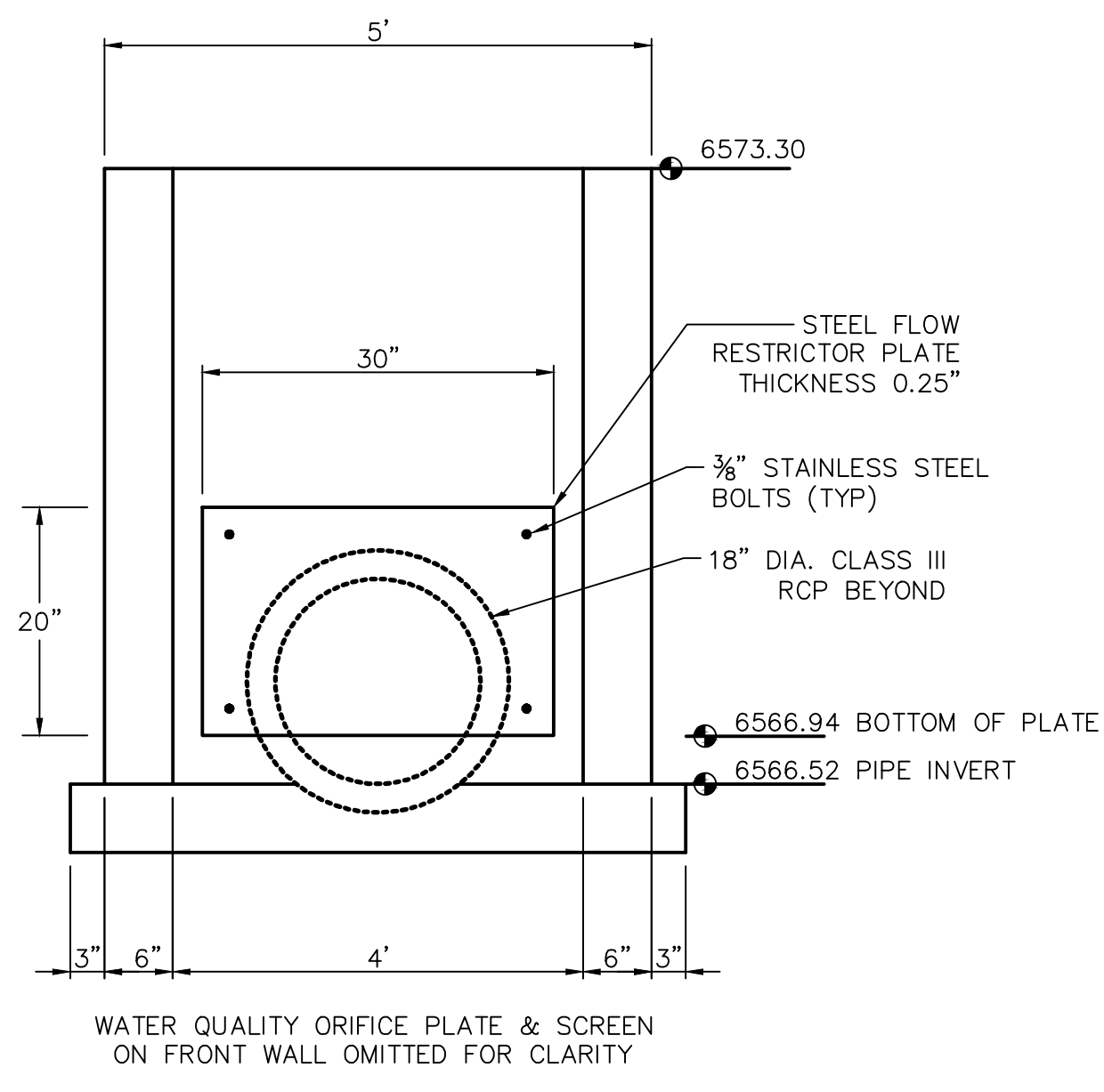

OVERFLOW STRUCTURE SECTION
NOT TO SCALE

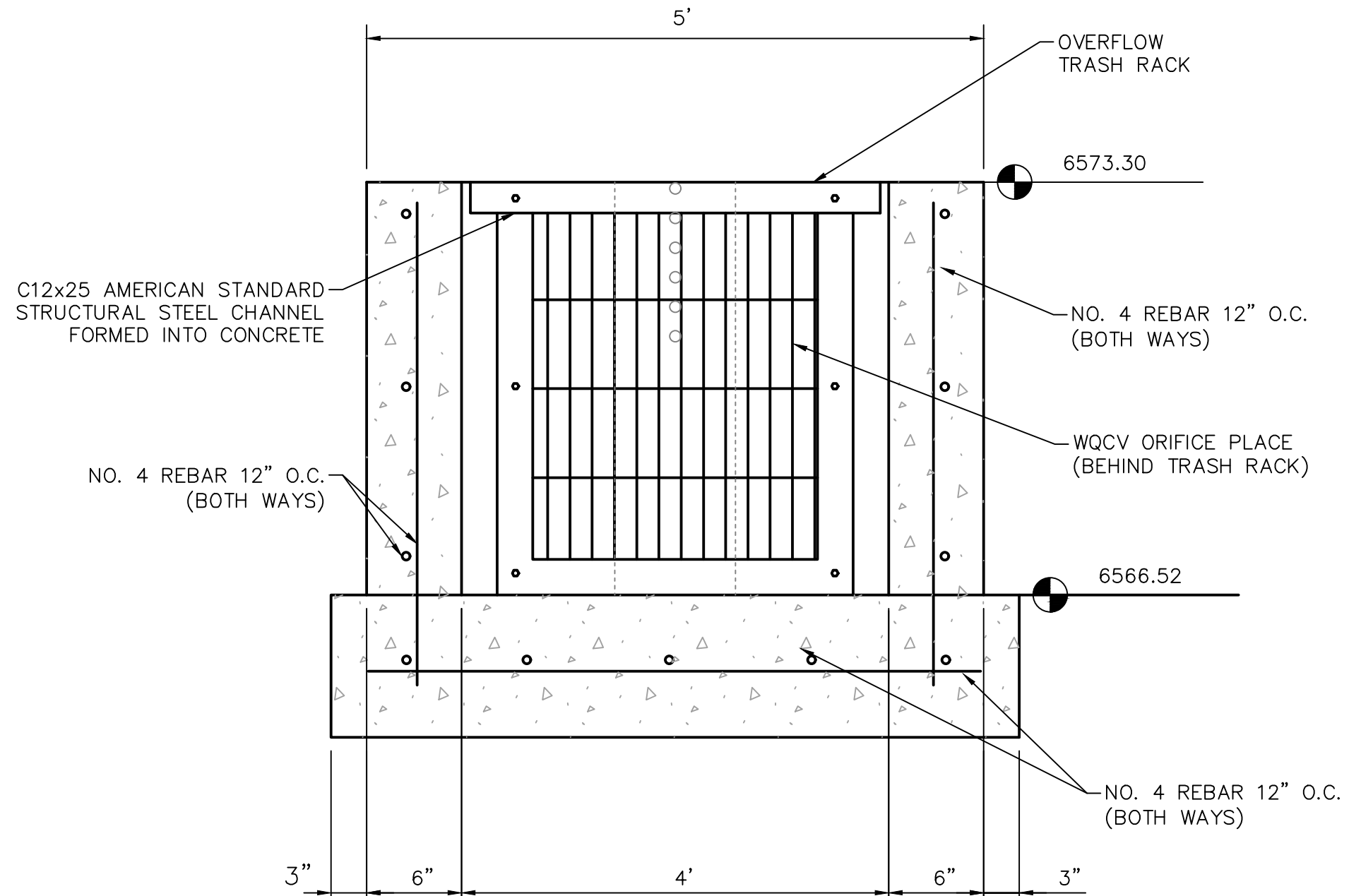

ELEVATION

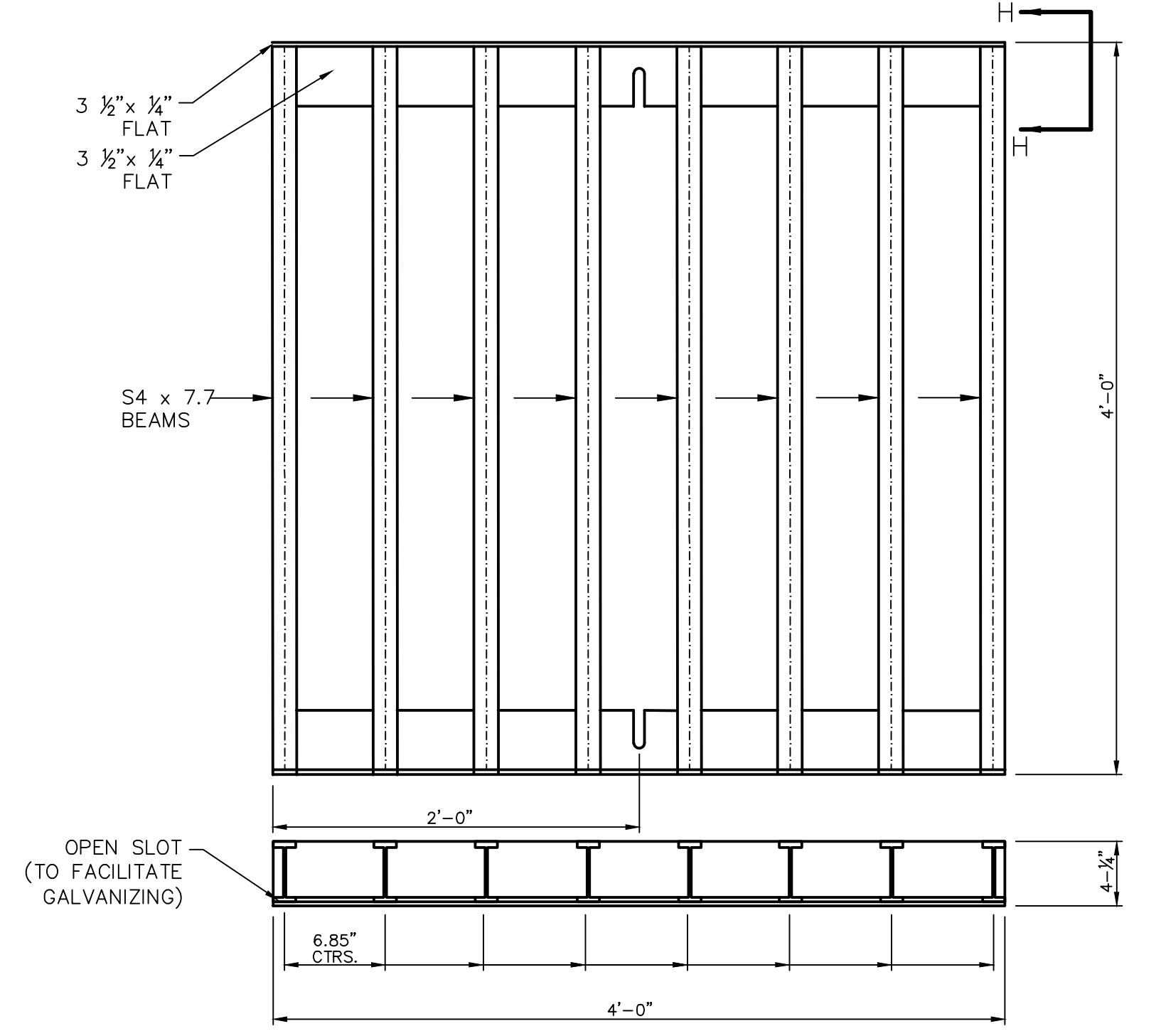

STANDARD INLET GRATE
NOT TO SCALE

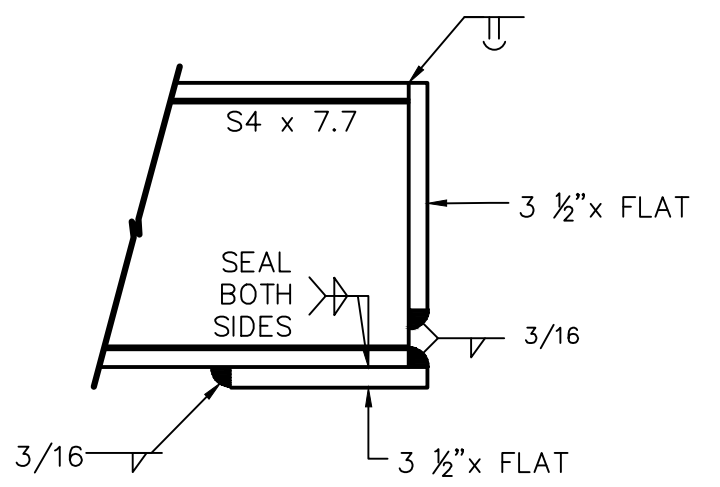

SECTION H-H

V:\52876\active\187608744-Mule Deer\CAD\Sheets\Construction Drawings\23 - North Pond.dwg
2019/12/16 2:13 PM By: Lauver, Lisa

Computer File Information	
Creation Date: 4-25-17	Initials: CMD
Last Modification Date:	Initials:
Full Path & Drawing File Name:	
Acad Ver. 2014	Scale: Units: Feet

Index of Revisions	

Stantec
Stantec Consulting Inc.
5725 MARK DABLING BLVD
Suite 190
Colorado Springs, CO 80919
Tel. (719) 594-4535
Fax.
www.stantec.com

GARDENS AT NORTH CAREFREE NORTH WQ POND DETAILS		Project No./Code
		187608744
Designer: CD	Structure Numbers	
Detailer: MB		
Sheet Subset:		SHEET 25 OF 34

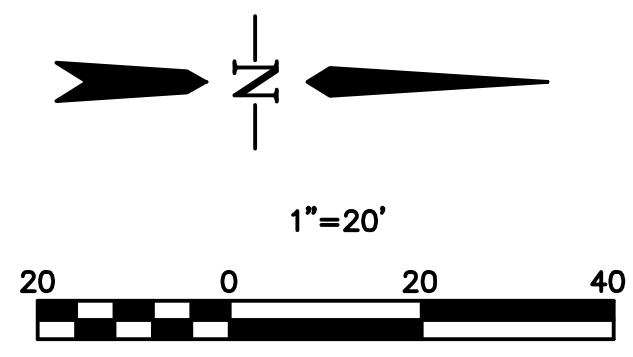
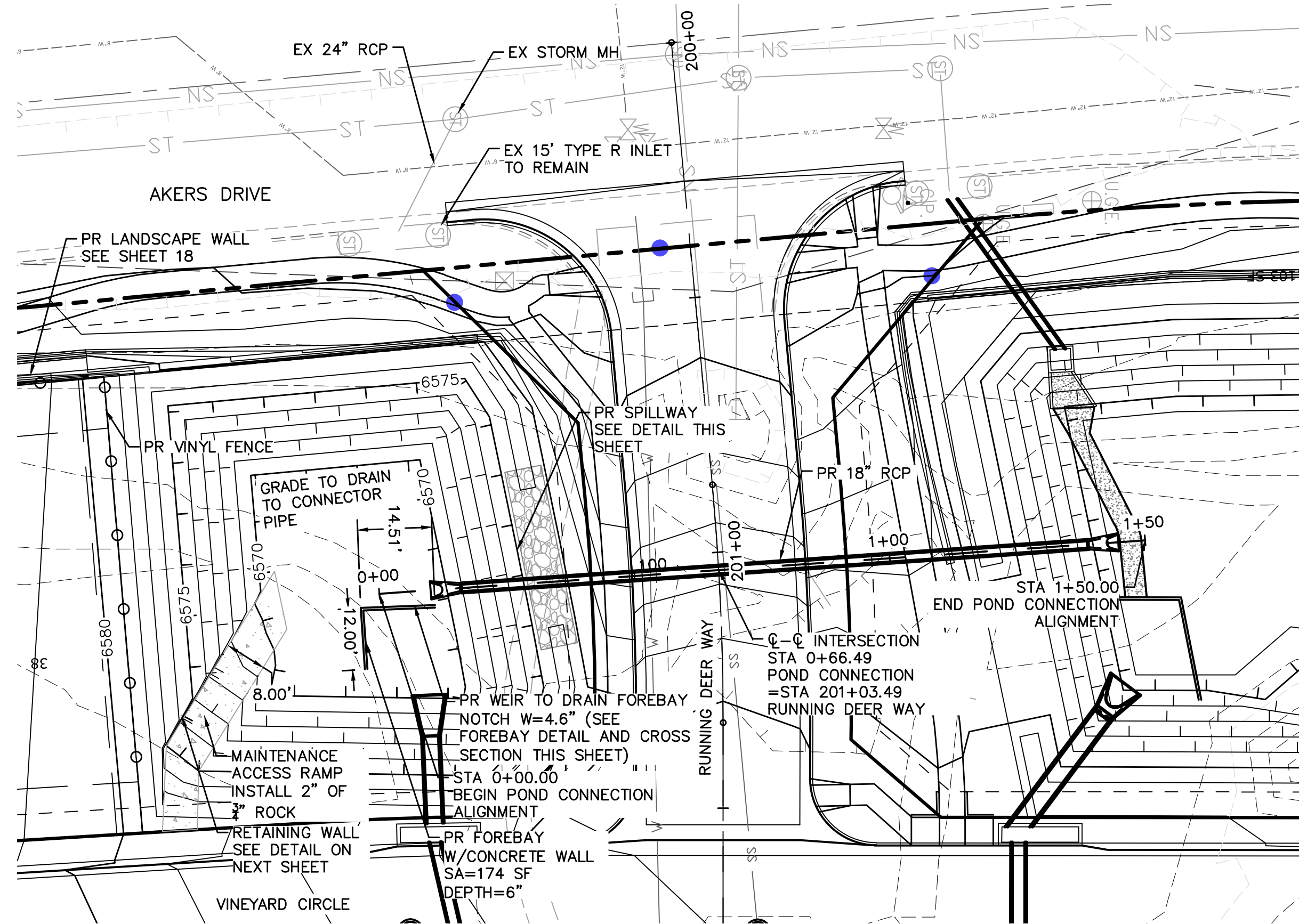

LINE TABLE: ALIGNMENTS						
LINE #	LENGTH	START STA	END STA	DIRECTION	START POINT (EAST, NORTH)	END POINT (EAST, NORTH)
L100	150.00	0+00.00	1+50.00	N3° 59' 09.43"W	(3322.97,5625.79)	(3312.54,5775.42)

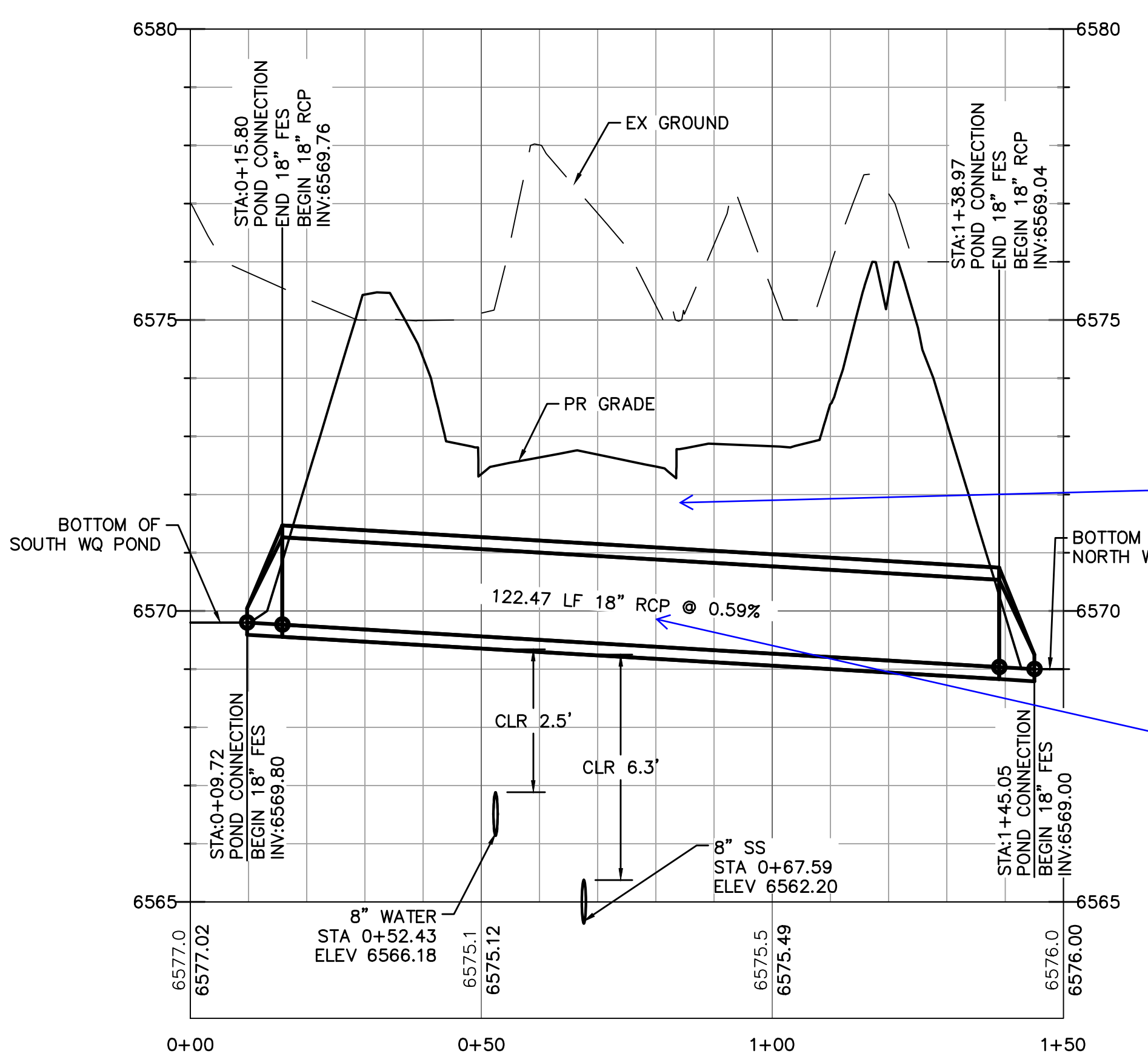
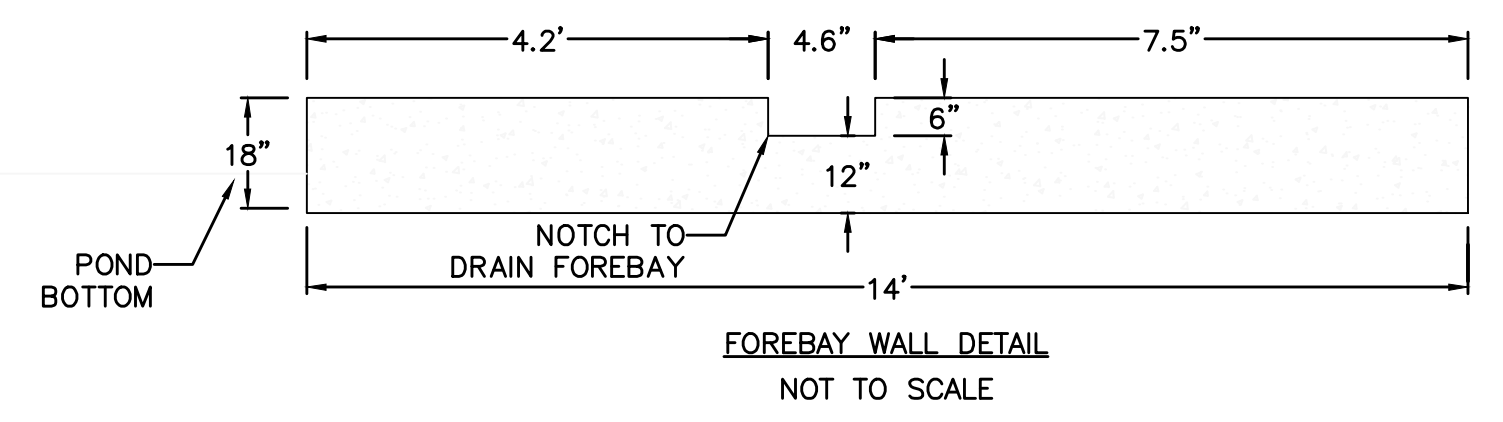

Per ECM Section 4.3.6 at no time shall storm sewer lines be placed less than 2 ft. depth from the finished road surface. If 2ft clearance cannot be achieved then a higher class RCP may be specified (use class IV) but a deviation form must be provided.

label as private

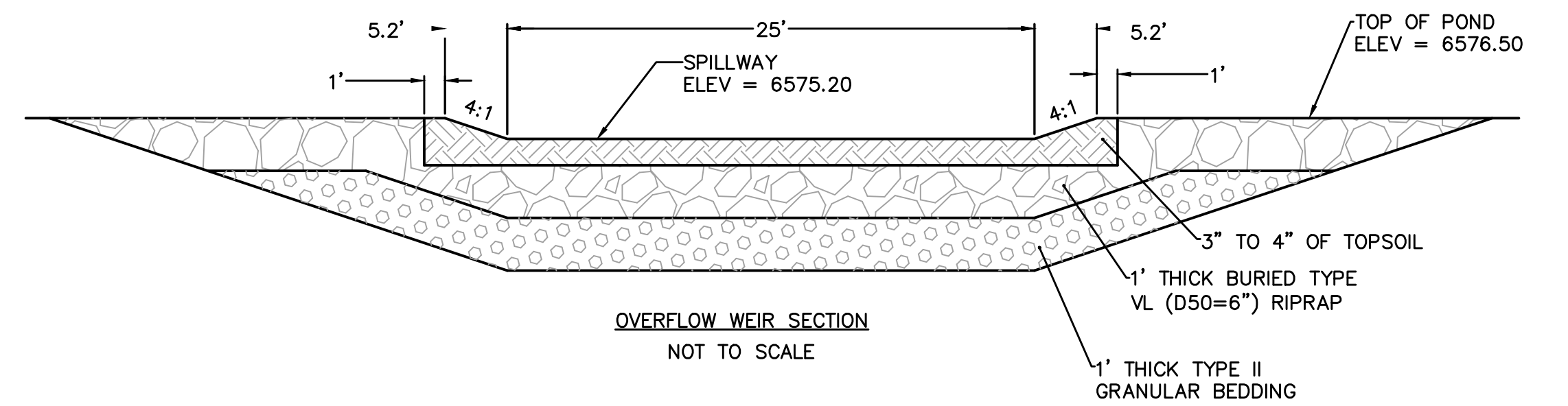
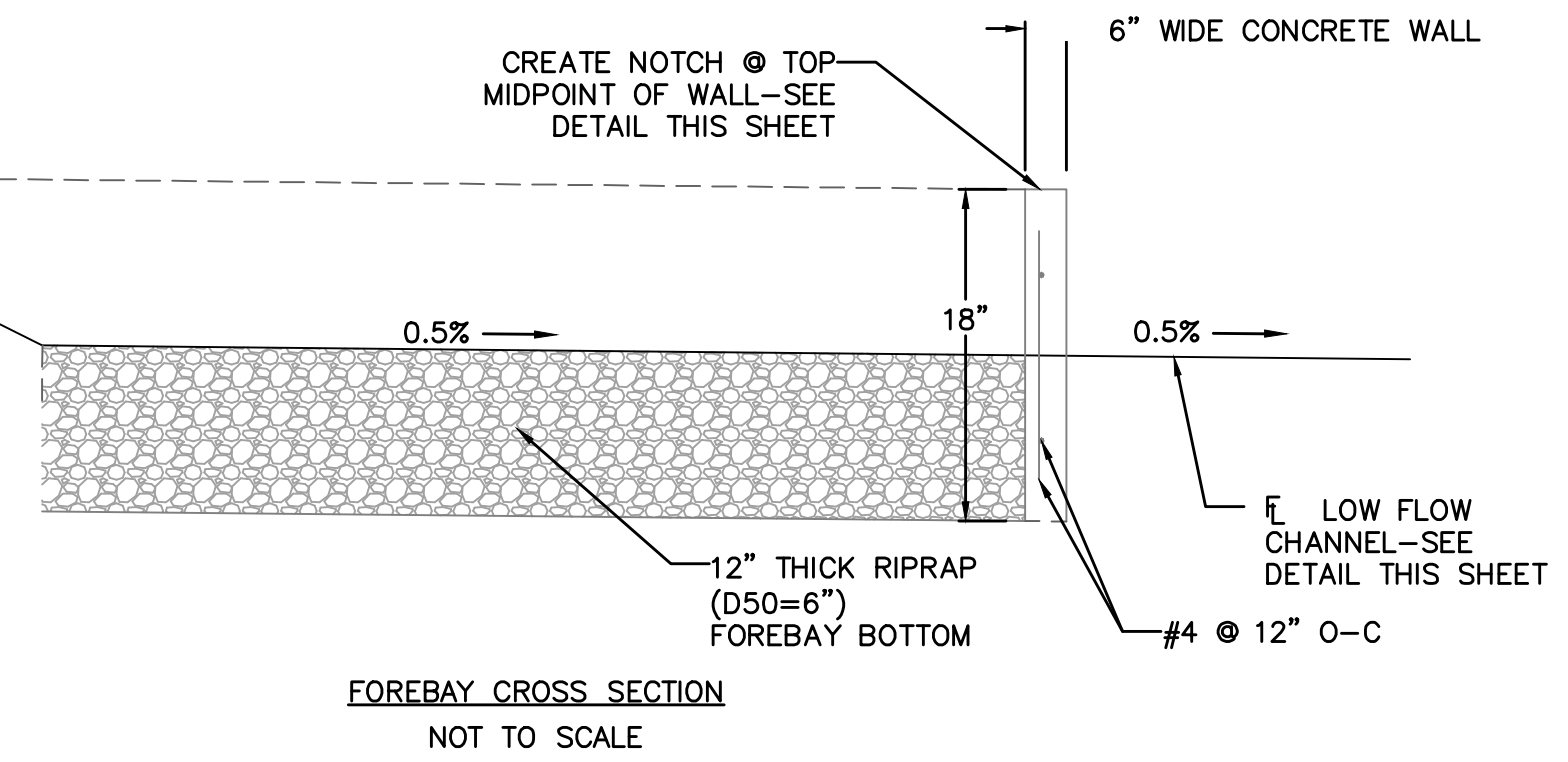

V:\52876\active\187608744-Mule Deer\CAD\Sheets\Construction Drawings\25 - South Pond.dwg 2019/12/12 12:33 PM By: Pearce, Taylor

Computer File Information	
Creation Date: 4-25-17	Initials: CMD
Last Modification Date:	Initials:
Full Path & Drawing File Name:	
Acad Ver. 2014	Scale: Units: Feet

Index of Revisions	
0000	
0000	
0000	
0000	

Stantec Consulting Inc.
5725 MARK DABLING BLVD
Suite 190
Colorado Springs, CO 80919
Tel. (719) 594-4535
Fax.
www.stantec.com

GARDENS AT NORTH CAREFREE SOUTH WQ POND		
Designer: CD	Structure Numbers	
Detailer: MB		
Sheet Subset:		

Project No./Code
187608744
SHEET 26 OF 34

SHEET NOT USED

NIC

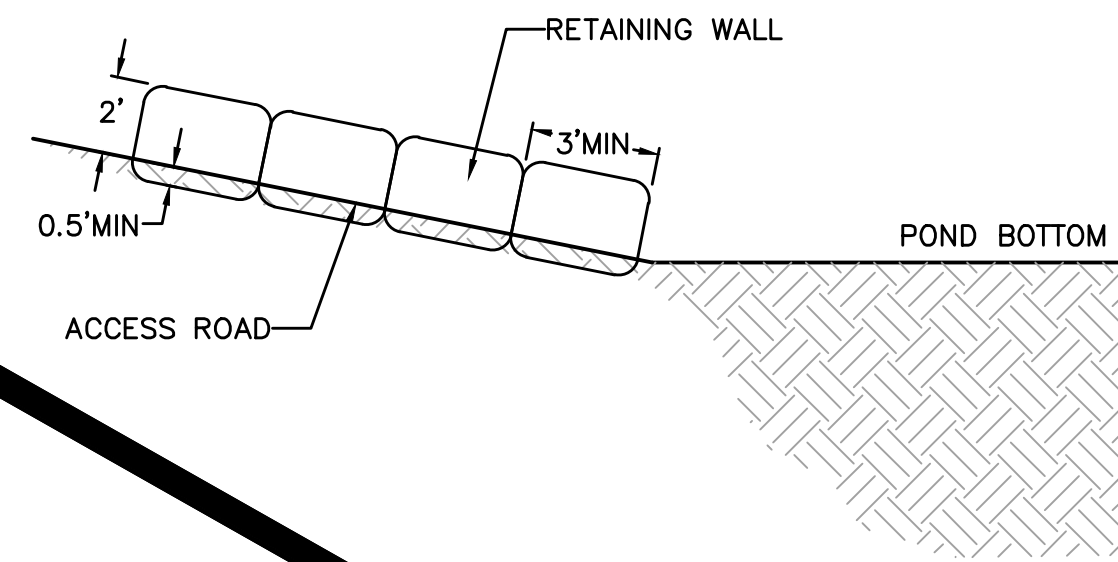

RETAINING WALL DETAIL
NOT TO SCALE

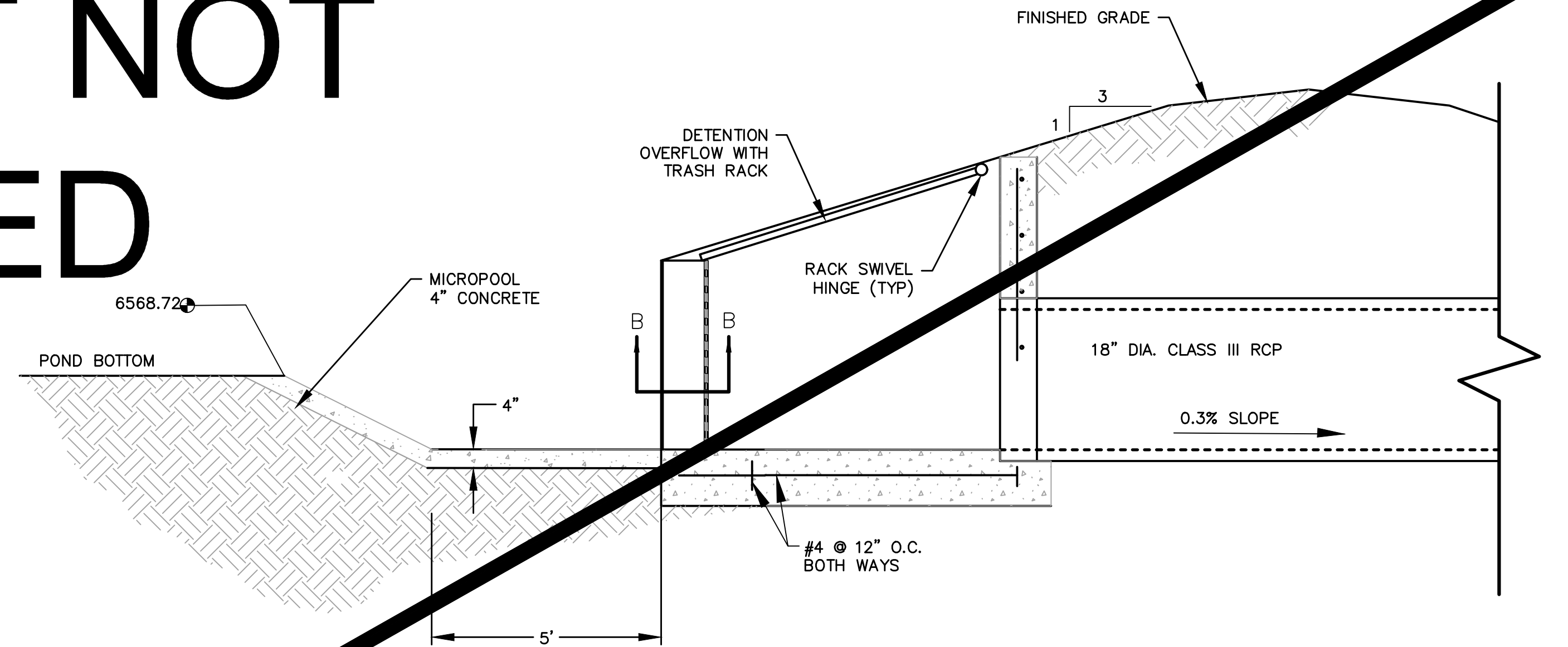

DETENTION BASIN OUTLET STRUCTURE

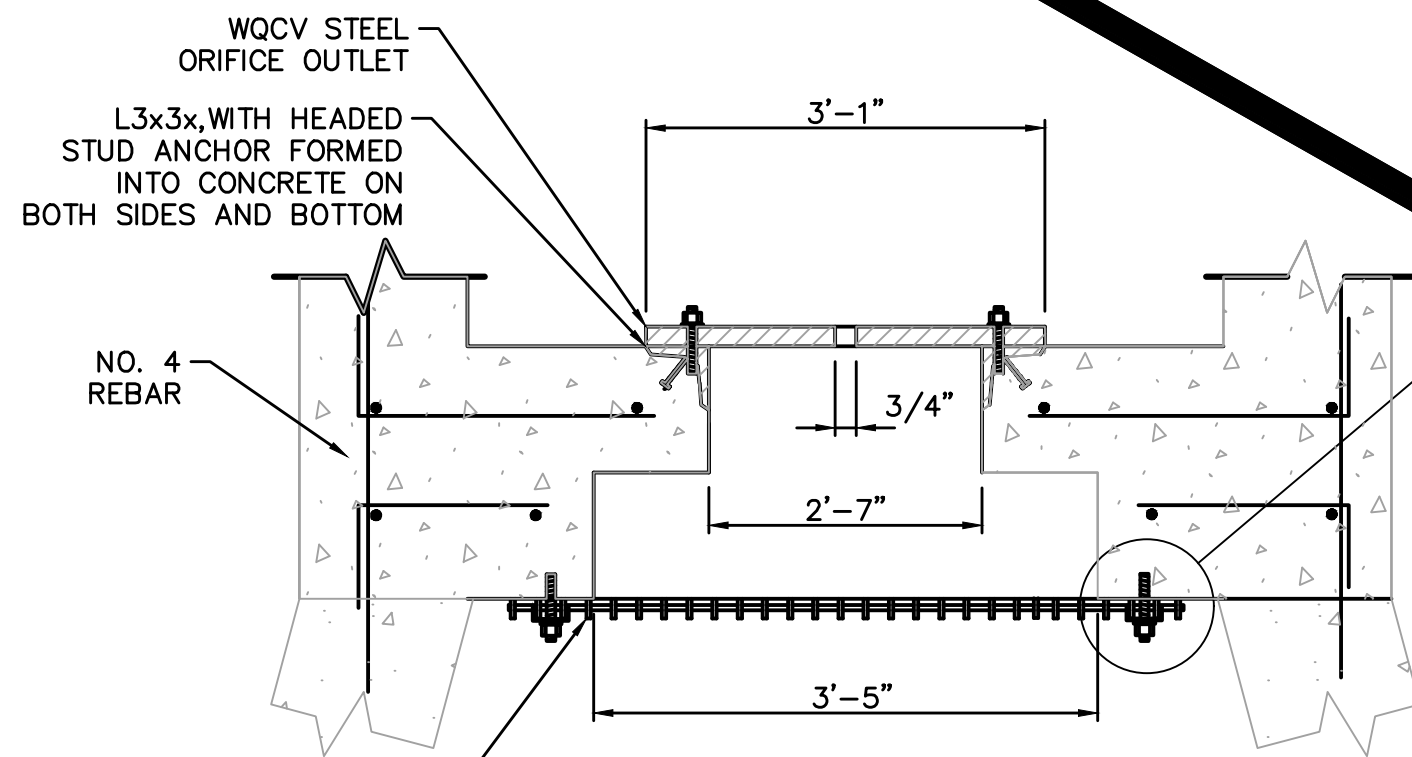

WQCV TRASH RACK AND ORIFICE PLATE SECTION B-B

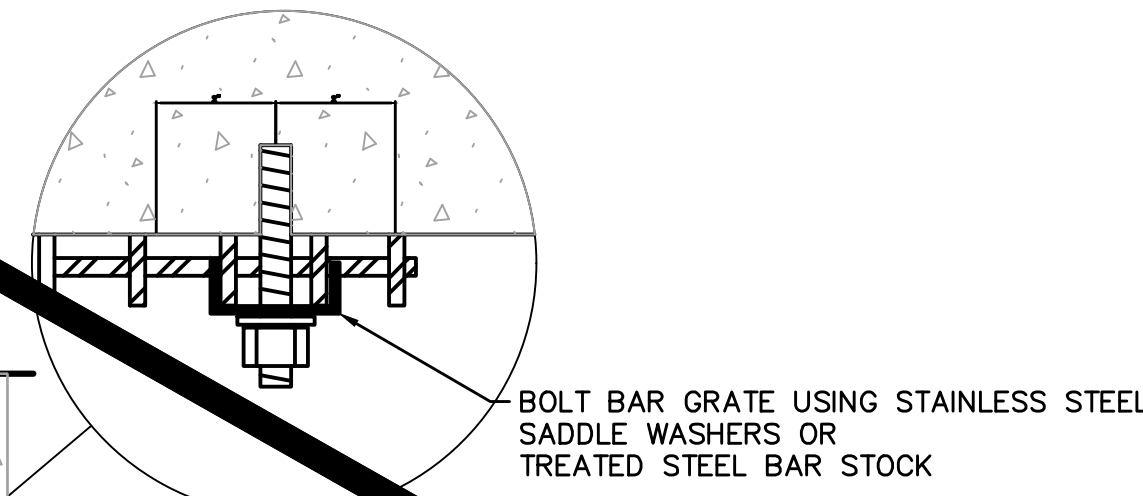

WQCV TRASH RACK AND ORIFICE PLATE SECTION C-C

1. KLEMP SP SERIES (OR EQUAL) ALUMINUM BAR GRATE. 1/2" WIDTH BARS ON 1-3/16" CENTERS.
2. R VALUE = (NET OPEN AREA)/(GROSS RACK AREA) = 0.71 FOR CROSS RODS ON 2" CENTERS.
3. KLEMP CORPORATION, OREM, UTAH, USA.

NOTES:
REINFORCING BARS SHALL HAVE A 2 INCH MINIMUM CLEARANCE.

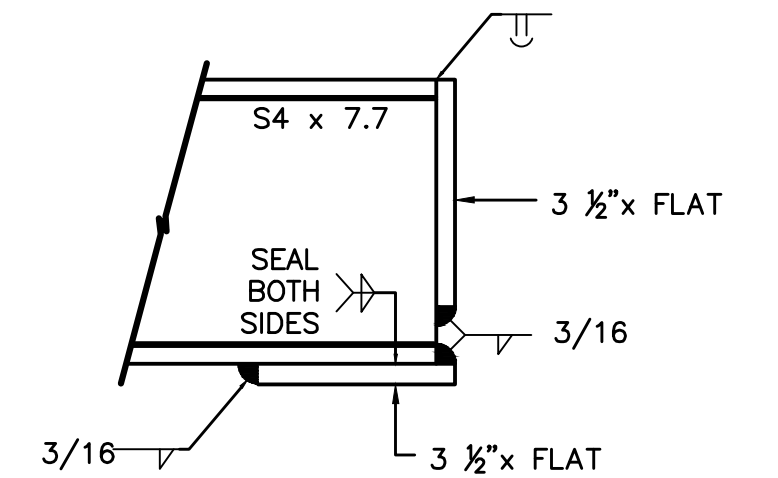

SECTION H-H

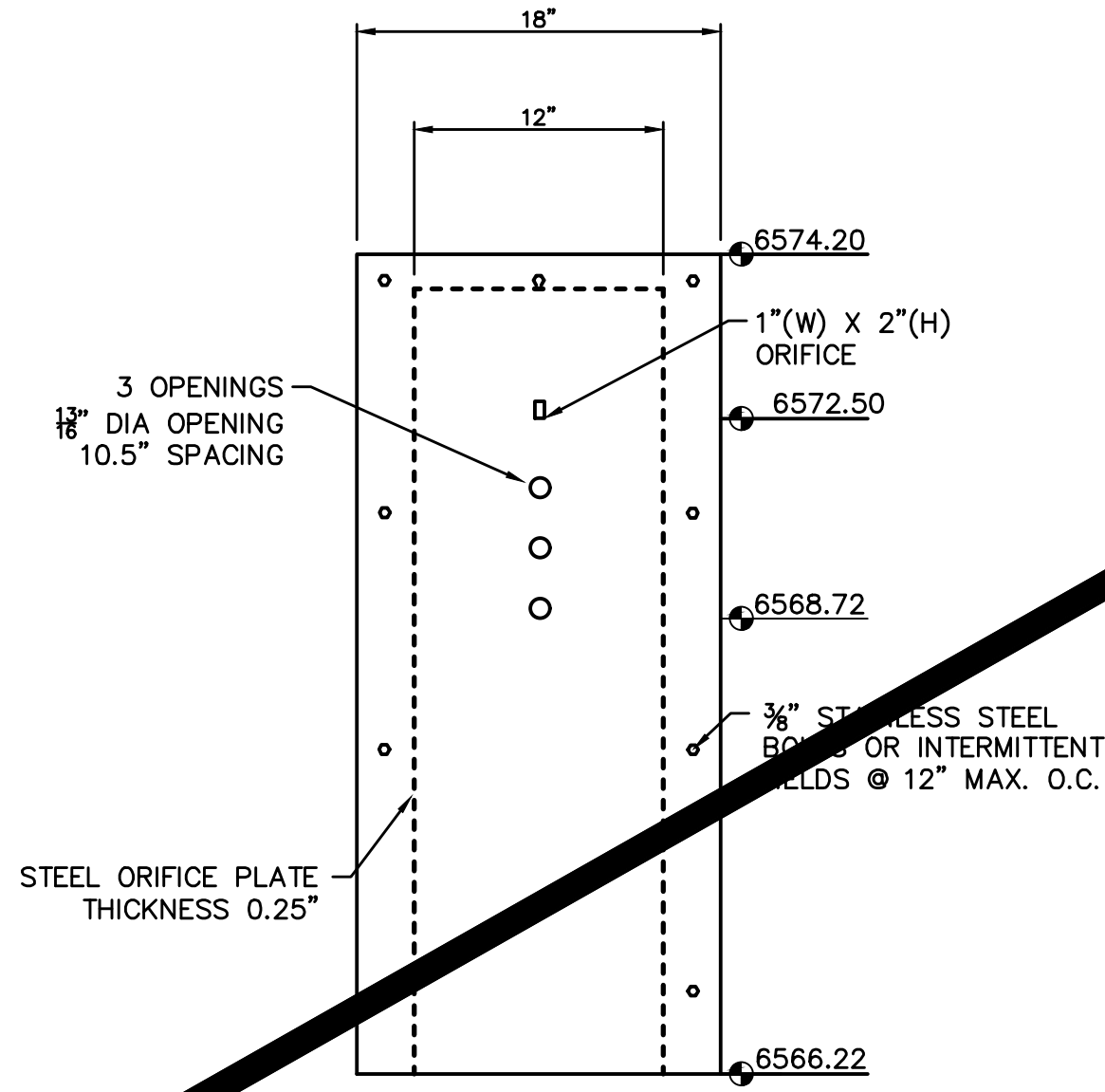

WQCV ORIFICE PLATE
NOT TO SCALE

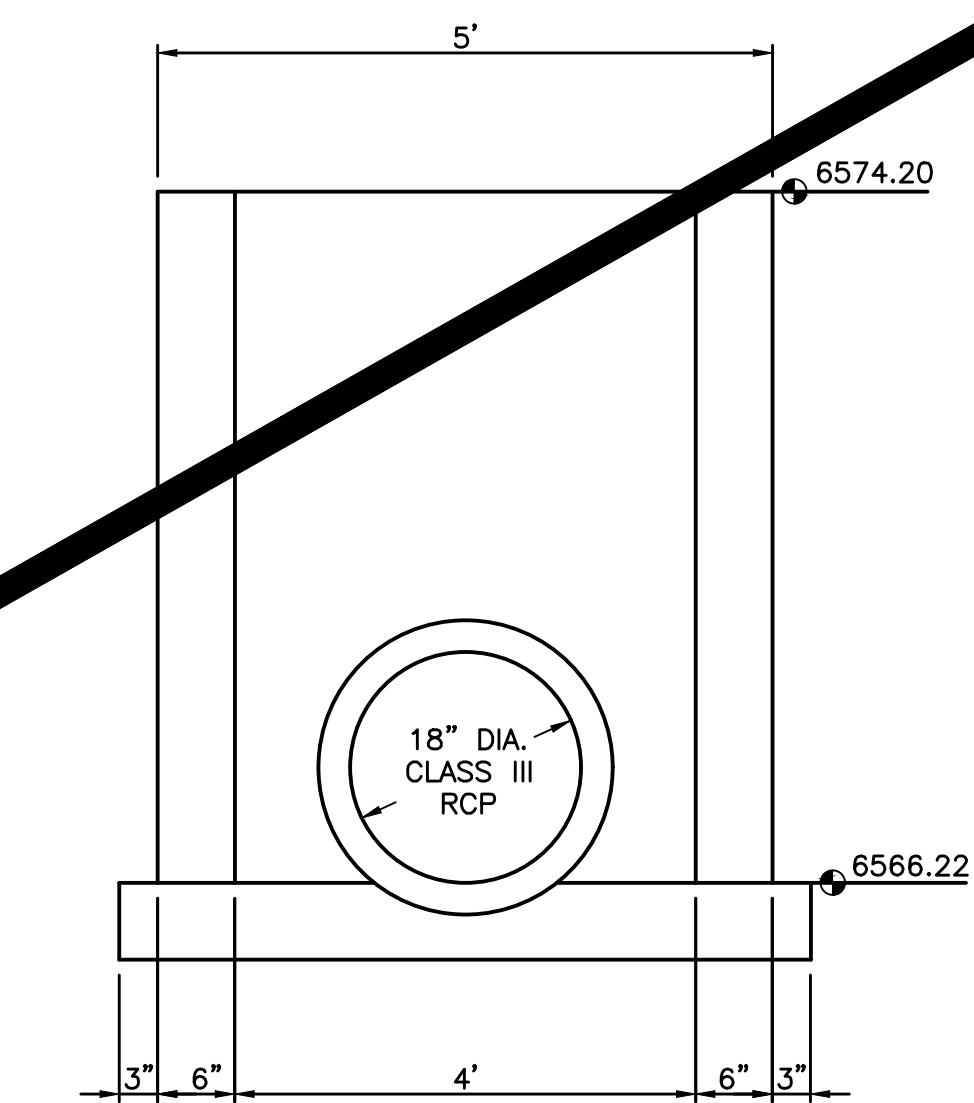

OVERFLOW STRUCTURE SECTION
NOT TO SCALE

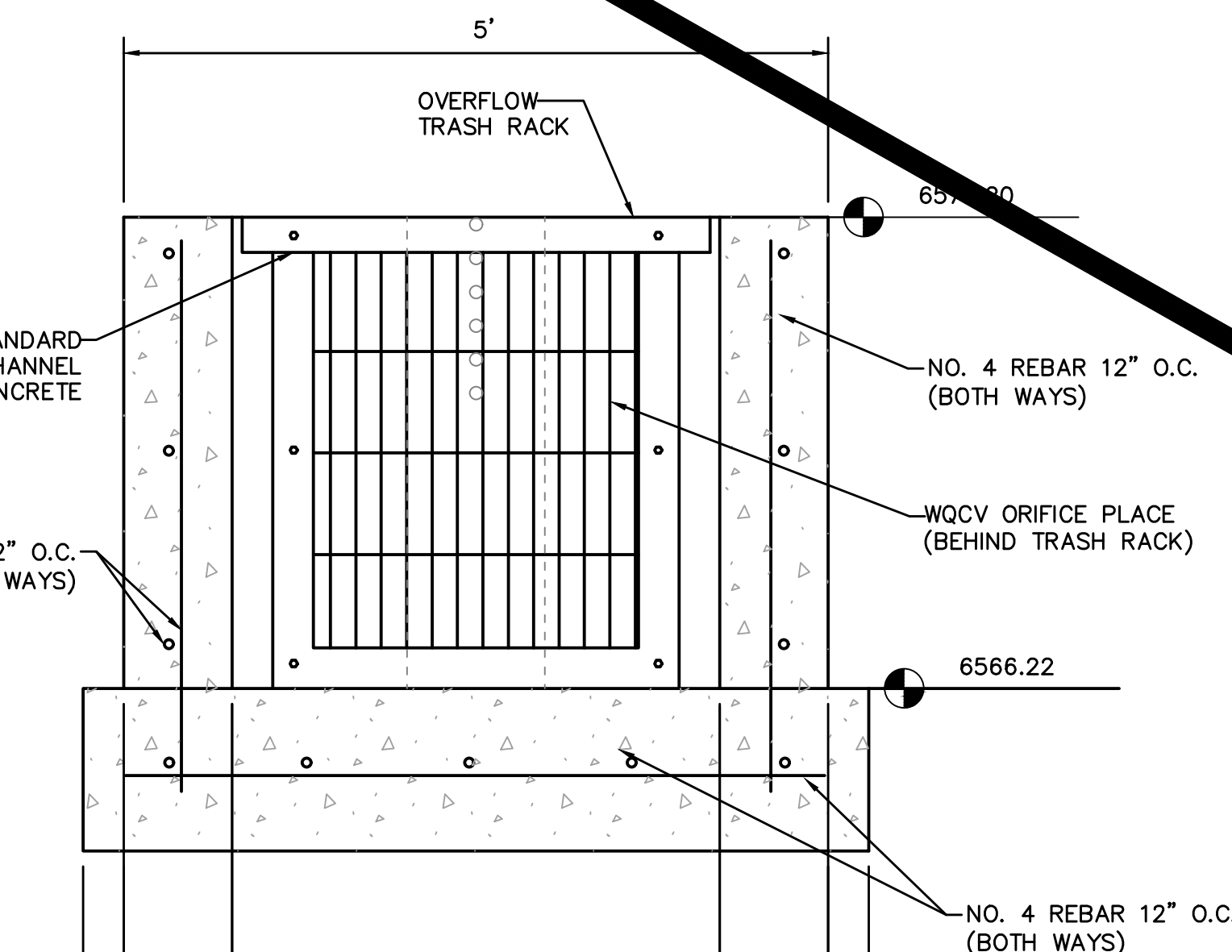

ELEVATION

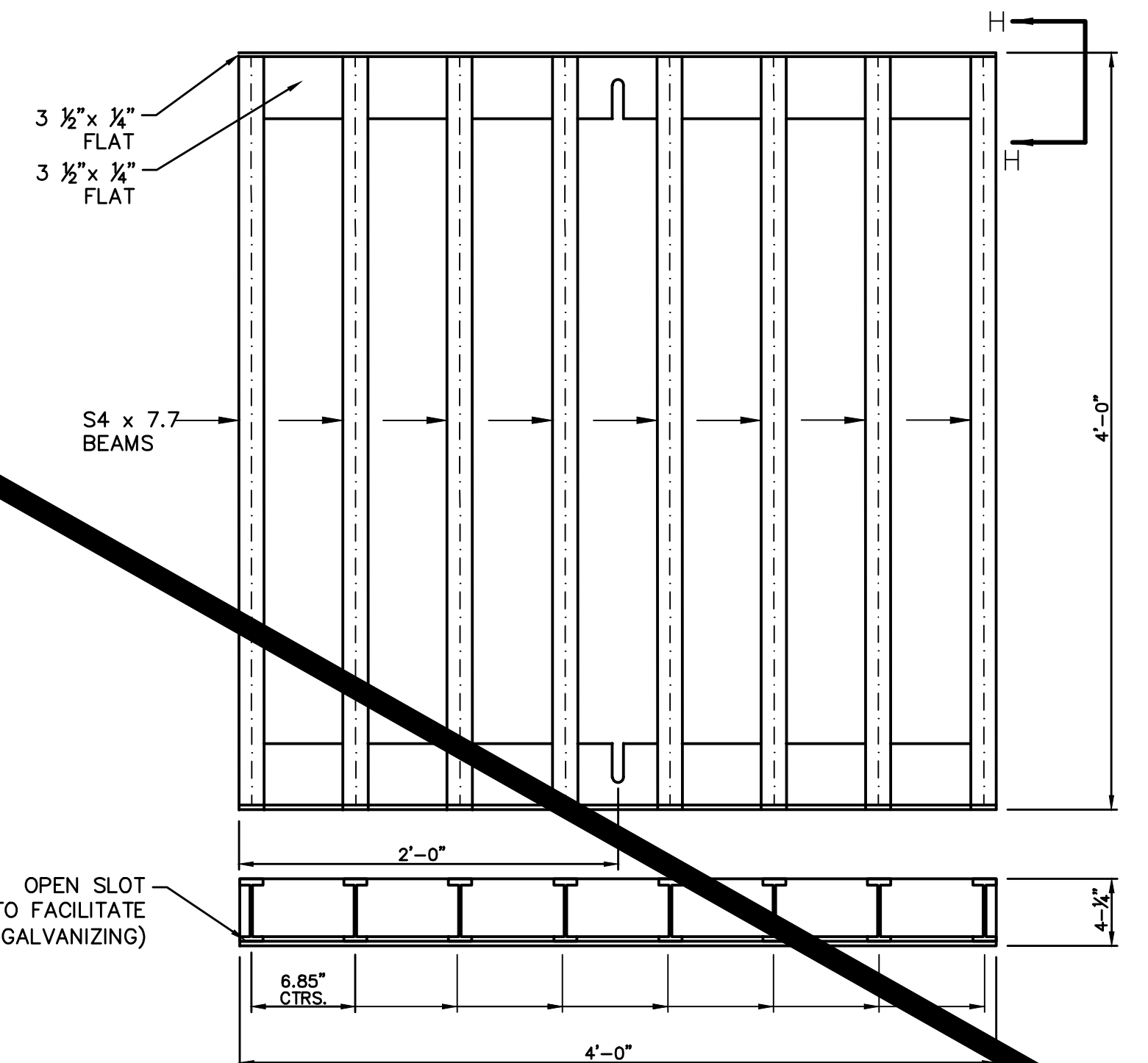

STANDARD INLET GRATE
NOT TO SCALE

V:\52876\active\187608744-Mule Deer\CAD\Sheets\Construction Drawings\25 - South Pond.dwg 2019/12/11 2:24 PM By: Pearce, Taylor

Computer File Information

Creation Date: 4-25-17	Initials: CMD
Last Modification Date:	Initials:
Full Path & Drawing File Name:	
Acad Ver. 2014	Scale: Units: Feet

Index of Revisions

Stantec
Stantec Consulting Inc.
5725 MARK DABLING BLVD
Suite 190
Colorado Springs, CO 80919
Tel. (719) 594-4535
Fax.
www.stantec.com

**GARDENS AT NORTH CAREFREE
SOUTH WQ POND DETAILS**

Designer: CD	Structure Numbers
Detailer: MB	
Sheet Subst:	

Project No./Code
187608744

V:\52876\active\187608744-Mule Deer\CAD\Sheets\Construction Drawings\28 - Grading And Erosion Control Plan.dwg
 2019/12/19 1:26 PM By: Pearce, Taylor

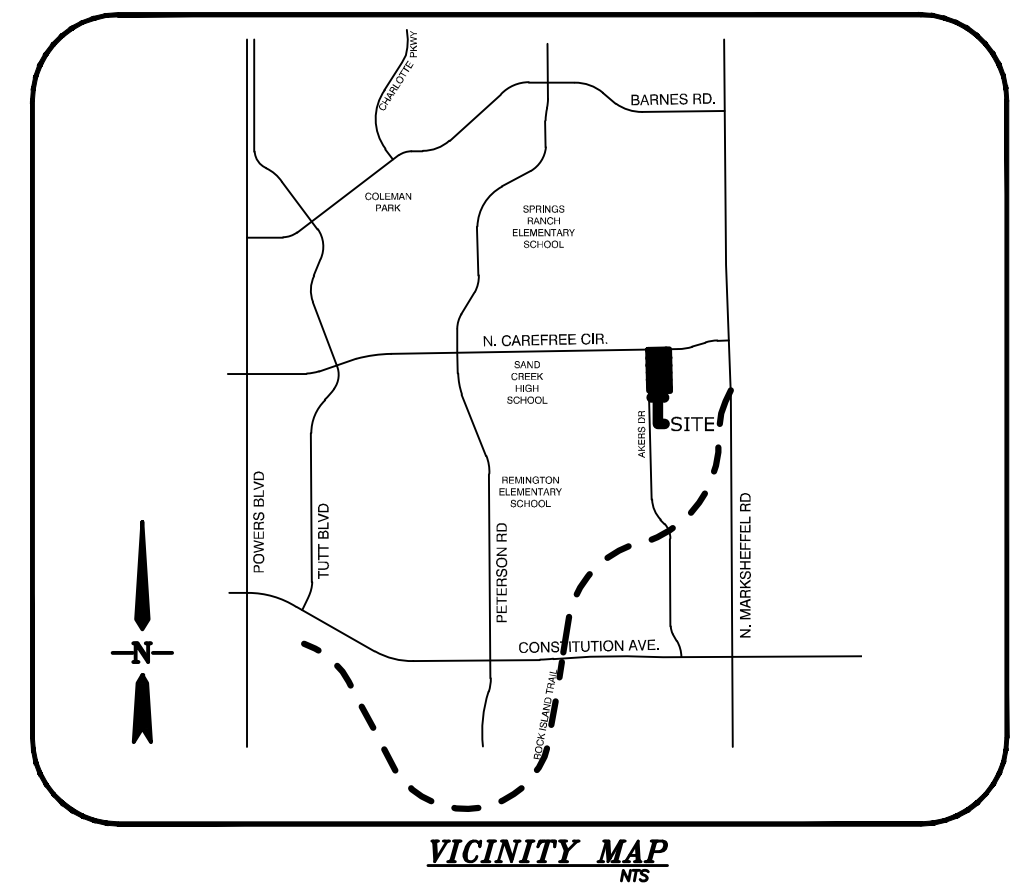
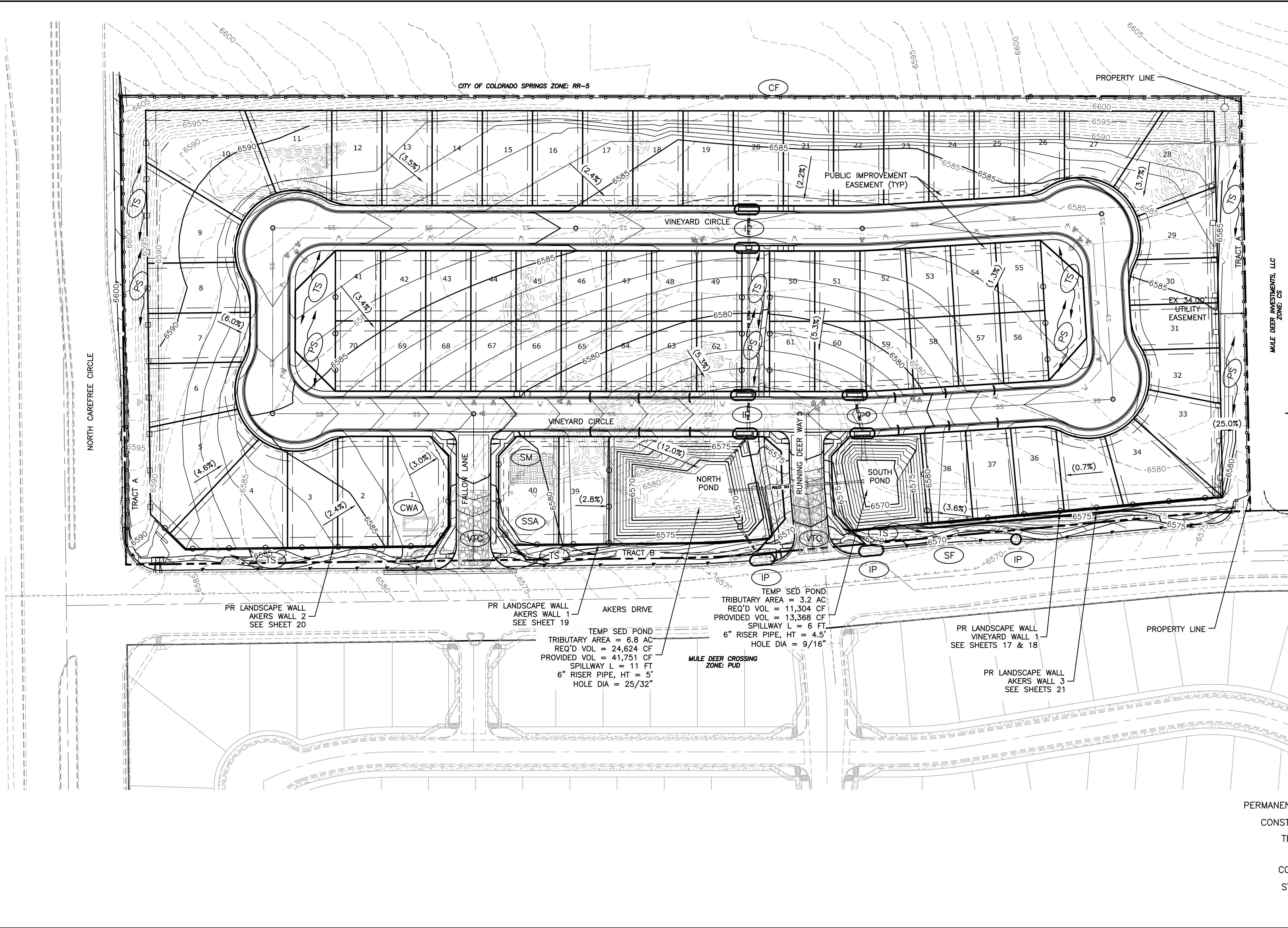

VICINITY MAP

MULE DEER INVESTMENTS, LLC
 ZONE CS

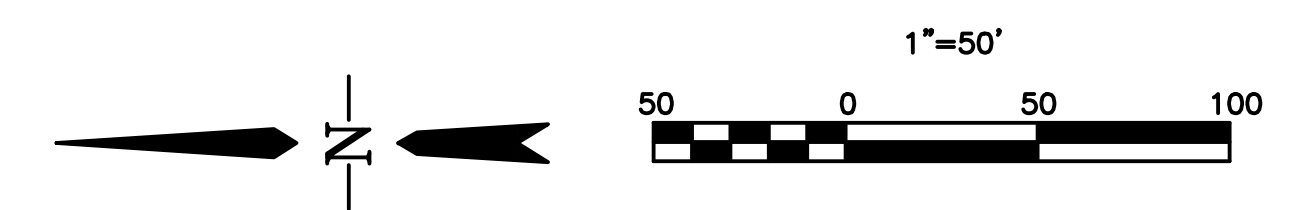

NOTES:

- EXISTING VEGETATION CONSISTS OF NATURAL GRASS AND WEEDS THROUGHOUT ENTIRETY OF SITE.

LEGEND

- EX MINOR CONTOUR ---
- EX MAJOR CONTOUR --- 5200
- PR MINOR CONTOUR ---
- PR MAJOR CONTOUR --- 5200
- PROPERTY LINE ---
- SILT FENCE (INITIAL) SF
- EROSION/STRAW BALES (INITIAL)
- INLET PROTECTION (INITIAL) IP
- VEHICLE TRACKING (INITIAL) VTC
- PERMANENT SEEDING & MULCHING (FINAL) PS
- CONSTRUCTION/SAFETY FENCE (INITIAL) CF
- TEMPORARY SEEDING & MULCHING TS
- CONCRETE WASHOUT AREA (INITIAL) CWA
- STABILIZED STAGING AREA (INITIAL) SSA
- STOCKPILE MANAGEMENT (INITIAL) SM

Computer File Information	
Creation Date: 4-25-17	Initials: CMD
Last Modification Date:	Initials:
Full Path & Drawing File Name:	
Acad Ver. 2014	Scale: Units: Feet

Index of Revisions	

NOTE: ALL SLOPES ARE 3:1 MAXIMUM UNLESS OTHERWISE INDICATED. PROPOSED CONTOURS SHOWN ARE 1 FOOT CONTOURS.

Stantec
 Stantec Consulting Inc.
 5725 MARK DABLING BLVD
 Suite 190
 Colorado Springs, CO 80919
 Tel. (719) 594-4535
 Fax.
 www.stantec.com

Designer: CD	Structure Numbers
Detailer: MB	
Sheet Subset:	

**GARDENS AT NORTH CAREFREE
 GRADING & EROSION CONTROL PLAN**

Project No./Code	187608744
SHEET	28 OF 34

**STANDARD NOTES FOR EL PASO COUNTY
GRADING AND EROSION CONTROL PLANS**

- Stormwater discharges from construction sites shall not cause or threaten to cause pollution, contamination, or degradation of State Waters. All work and earth disturbance shall be done in a manner that minimizes pollution of any on-site or off-site waters, including wetlands.
- Notwithstanding anything depicted in these plans in words or graphic representation, all design and construction related to roads, storm drainage and erosion control shall conform to the standards and requirements of the most recent version of the relevant adopted El Paso County standards, including the Land Development Code, the Engineering Criteria Manual, the Drainage Criteria Manual, and the Drainage Criteria Manual Volume 2. Any deviations from regulations and standards must be requested, and approved, in writing.
- A separate Stormwater Management Plan (SMWP) for this project shall be completed and an Erosion and Stormwater Quality Control Permit (ESQCP) issued prior to commencing construction. Management of the SWMP during construction is the responsibility of the designated Qualified Stormwater Manager or Certified Erosion Control Inspector. The SWMP shall be located on site at all times during construction and shall be kept up to date with work progress and changes in the field.
- Once the ESQCP is approved and a "Notice to Proceed" has been issued, the contractor may install the initial stage erosion and sediment control measures as indicated on the approved GEC. A Preconstruction Meeting between the contractor, engineer, and El Paso County will be held prior to any construction. It is the responsibility of the applicant to coordinate the meeting time and place with County staff.
- Control measures must be installed prior to commencement of activities that could contribute pollutants to stormwater. Control measures for all slopes, channels, ditches, and disturbed land areas shall be installed immediately upon completion of the disturbance.
- All temporary sediment and erosion control measures shall be maintained and remain in effective operating condition until permanent soil erosion control measures are implemented and final stabilization is established. All persons engaged in land disturbance activities shall assess the adequacy of control measures at the site and identify if changes to those control measures are needed to ensure the continued effective performance of the control measures. All changes to temporary sediment and erosion control measures must be incorporated into the Stormwater Management Plan.
- Temporary stabilization shall be implemented on disturbed areas and stockpiles where ground disturbing construction activity has permanently ceased or temporarily ceased for longer than 14 days.
- Final stabilization must be implemented at all applicable construction sites. Final stabilization is achieved when all ground disturbing activities are complete and all disturbed areas either have a uniform vegetative cover with individual plant density of 70 percent of pre-disturbance levels established or equivalent permanent alternative stabilization method is implemented. All temporary sediment and erosion control measures shall be removed upon final stabilization and before permit closure.
- All permanent stormwater management facilities shall be installed as designed in the approved plans. Any proposed changes that effect the design or function of permanent stormwater management structures must be approved by the ECM Administrator prior to implementation.
- Earth disturbances shall be conducted in such a manner so as to effectively minimize accelerated soil erosion and resulting sedimentation. All disturbances shall be designed, constructed, and completed so that the exposed area of any disturbed land shall be limited to the shortest practical period of time. Pre-existing vegetation shall be protected and maintained within 50 horizontal feet of a waters of the state unless shown to be infeasible and specifically requested and approved.
- Compaction of soil must be prevented in areas designated for infiltration control measures or where final stabilization will be achieved by vegetative cover. Areas designated for infiltration control measures shall also be protected from sedimentation during construction until final stabilization is achieved. If compaction prevention is not feasible due to site constraints, all areas designated for infiltration and vegetation control measures must be loosened prior to installation of the control measure(s).
- Any temporary or permanent facility designed and constructed for the conveyance of stormwater around, through, or from the earth disturbance area shall be a stabilized conveyance designed to minimize erosion and the discharge of sediment off site.
- Concrete wash water shall be contained and disposed of in accordance with the SWMP. No wash water shall be discharged to or allowed to enter State Waters, including any surface or subsurface storm drainage system or facilities. Concrete washouts shall not be located in an area where shallow groundwater may be present, or within 50 feet of a surface water body, creek or stream.
- During dewatering operations of uncontaminated ground water may be discharged on site, but shall not leave the site in the form of surface runoff unless an approved State dewatering permit is in place.
- Erosion control blanketing or other protective covering shall be used on slopes steeper than 3:1.

- Contractor shall be responsible for the removal of all wastes from the construction site for disposal in accordance with local and State regulatory requirements. No construction debris, tree slash, building material wastes or unused building materials shall be buried, dumped, or discharged at the site.
- Waste materials shall not be temporarily placed or stored in the street, alley, or other public way, unless in accordance with an approved Traffic Control Plan. Control measures may be required by El Paso County Engineering if deemed necessary, based on specific conditions and circumstances.
- Tracking of soils and construction debris off-site shall be minimized. Materials tracked off-site shall be cleaned up and properly disposed of immediately.
- The owner/developer shall be responsible for the removal of all construction debris, dirt, trash, rock, sediment, soil, and sand that may accumulate in roads, storm drains and other drainage conveyance systems and stormwater appurtenances as a result of site development.
- The quantity of materials stored on the project site shall be limited, as much as practical, to that quantity required to perform the work in an orderly sequence. All materials stored on-site shall be stored in a neat, orderly manner, in their original containers, with original manufacturer's labels.
- No chemical(s) having the potential to be released in stormwater are to be stored or used onsite unless permission for the use of such chemical(s) is granted in writing by the ECM Administrator. In granting approval for the use of such chemical(s), special conditions and monitoring may be required.
- Bulk storage of allowed petroleum products or other allowed liquid chemicals in excess of 55 gallons shall require adequate secondary containment protection to contain all spills onsite and to prevent any spilled materials from entering State Waters, any surface or subsurface storm drainage system or other facilities.
- No person shall cause the impediment of stormwater flow in the curb and gutter or ditch except with approved sediment control measures.
- Owner/developer and their agents shall comply with the "Colorado Water Quality Control Act" (Title 25, Article 8, CRS), and the "Clean Water Act" (33 USC 1344), in addition to the requirements of the Land Development Code, DCM Volume II and the ECM Appendix I. All appropriate permits must be obtained by the contractor prior to construction (1041, NPDES, Floodplain, 404, fugitive dust, etc.). In the event of conflicts between these requirements and other laws, rules, or regulations of other Federal, State, local, or County agencies, the most restrictive laws, rules, or regulations shall apply.
- All construction traffic must enter/exit the site only at approved construction access points.
- Prior to construction the permittee shall verify the location of existing utilities.
- A water source shall be available on site during earthwork operations and shall be utilized as required to minimize dust from earthwork equipment and wind.
- The soils report for this site has been prepared by ENTECH ENGINEERING, INC and shall be considered a part of these plans.
- At least ten (10) days prior to the anticipated start of construction, for projects that will disturb one (1) acre or more, the owner or operator of construction activity shall submit a permit application for stormwater discharge to the Colorado Department of Public Health and Environment, Water Quality Division. The application contains certification of completion of a stormwater management plan (SWMP), of which this Grading and Erosion Control Plan may be a part. For information or application materials contact:

Colorado Department of Public Health and Environment
Water Quality Control Division
WQCD - Permits
4300 Cherry Creek Drive South
Denver, CO 80246-1530
Attn: Permits Unit

GRADING AND EROSION CONTROL DETAILS AND NOTES

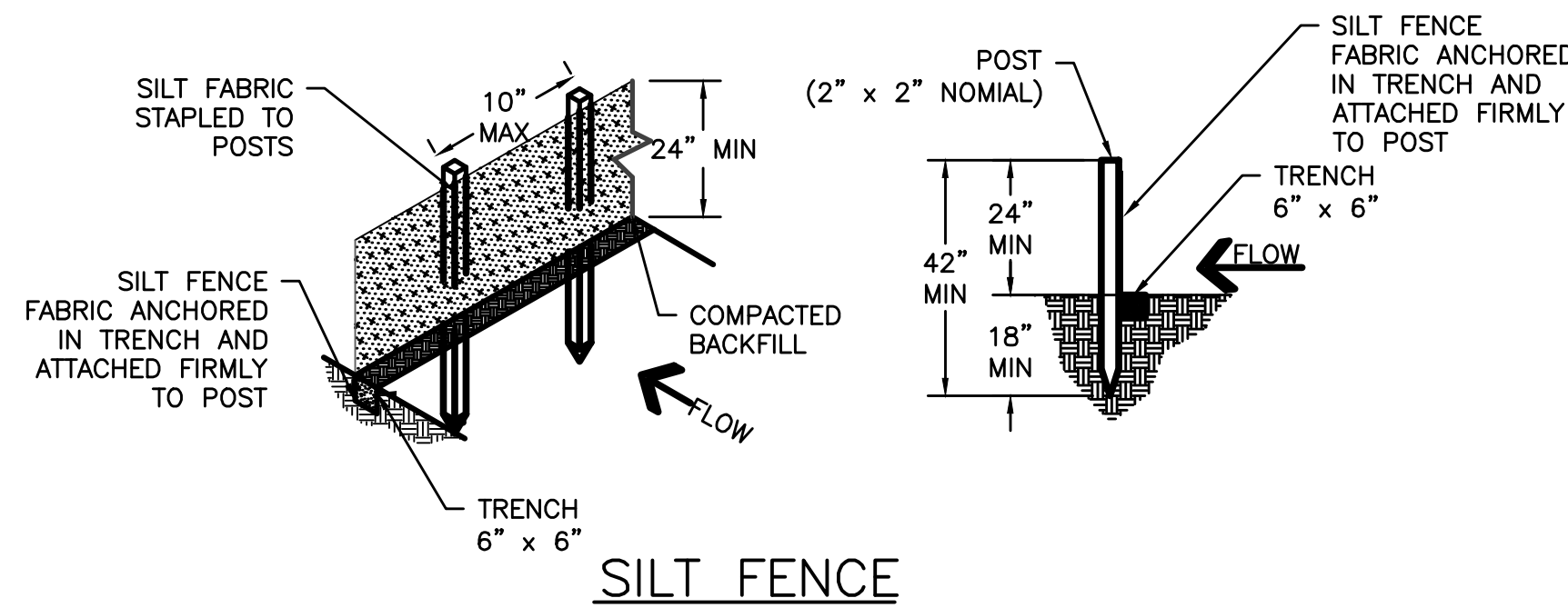

**SILT FENCE NOTES
INSTALLATION REQUIREMENTS**

- SILT FENCES SHALL BE INSTALLED PRIOR TO ANY LAND DISTURBING ACTIVITIES.
- WHEN JOINTS ARE NECESSARY, SILT FENCE GEOTEXTILE SHALL BE SPLICED TOGETHER ONLY AT SUPPORT POST AND SECURELY SEALED.
- METAL POSTS SHALL BE "STUDDED TEE" OR "U" TYPE WITH MINIMUM WEIGHT OF 1.33 POUNDS PER LINEAR FOOT. WOOD POSTS SHALL HAVE A MINIMUM DIAMETER OR CROSS SECTION DIMENSION OF 2 INCHES.
- THE FILTER MATERIAL SHALL BE FASTENED SECURELY TO METAL OR WOOD POSTS USING WIRE TIES, OR TO WOOD POSTS WITH 3/4" LONG #9 HEAVY-DUTY STAPLES. THE SILT FENCE GEOTEXTILE SHALL NOT BE STAPLED TO EXISTING TREES.
- WHILE NOT REQUIRED, WIRE MESH FENCE MAY BE USED TO SUPPORT THE GEOTEXTILE. WIRE FENCE SHALL BE FASTENED SECURELY TO THE UPSLOPE SIDE OF THE POSTS USING HEAVY-DUTY WIRE STAPLES AT LEAST 3/4" LONG, TIE WIRES OR HOG RINGS. THE WIRE SHALL EXTEND INTO THE TRENCH A MINIMUM OF 6" AND SHALL NOT EXTEND MORE THAN 3' ABOVE THE ORIGINAL GROUND SURFACE.
- ALONG THE TOE OF FILLS, INSTALL THE SILT FENCE ALONG A LEVEL CONTOUR AND PROVIDE AN AREA BEHIND THE FENCE FOR RUNOFF TO POND AND SEDIMENT TO SETTLE. A MINIMUM DISTANCE OF 5 FEET FROM THE TOE OF THE FILL IS RECOMMENDED.
- THE HEIGHT OF THE SILT FENCE FROM THE GROUND SURFACE SHALL BE MINIMUM OF 24 INCHES AND SHALL NOT EXCEED 36 INCHES; HIGHER FENCES MAY INPOUND VOLUMES OF WATER SUFFICIENT TO CAUSE FAILURE OF THE STRUCTURE.

MAINTENANCE REQUIREMENTS

- CONTRACTOR SHALL INSPECT SILT FENCES IMMEDIATELY AFTER EACH RAINFALL, AT LEAST DAILY DURING PROLONGED RAINFALL, AND WEEKLY DURING PERIODS OF NO RAINFALL, DAMAGED, COLLAPSED, UNENTRENCHED OR INEFFECTIVE SILT FENCES SHALL BE PROMPTLY REPAIRED OR REPLACED.
- SEDIMENT SHALL BE REMOVED FROM BEHIND SILT FENCE WHEN IT ACCUMULATES TO HALF THE EXPOSED GEOTEXTILE HEIGHT.
- SILT FENCES SHALL REMOVED WHEN ADEQUATE VEGETATIVE COVER IS ATTAINED AS APPROVED BY THE CITY.

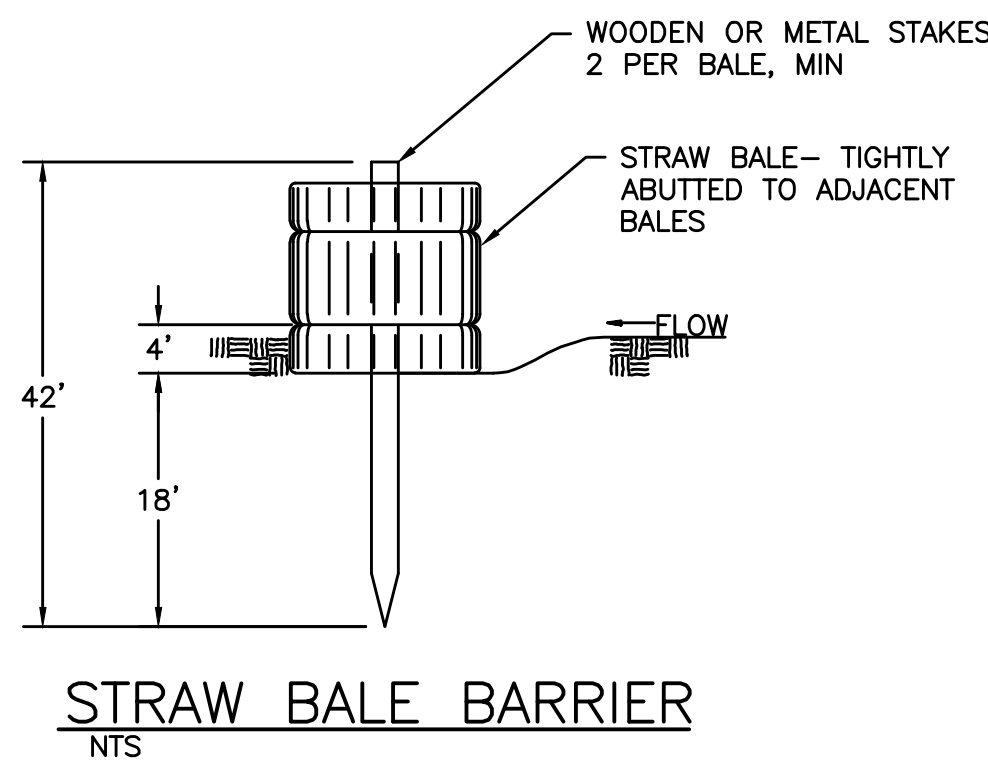

**STRAW BALE BARRIER
NTS**

TOP VIEW OF SILT FENCE POSTS DETAIL

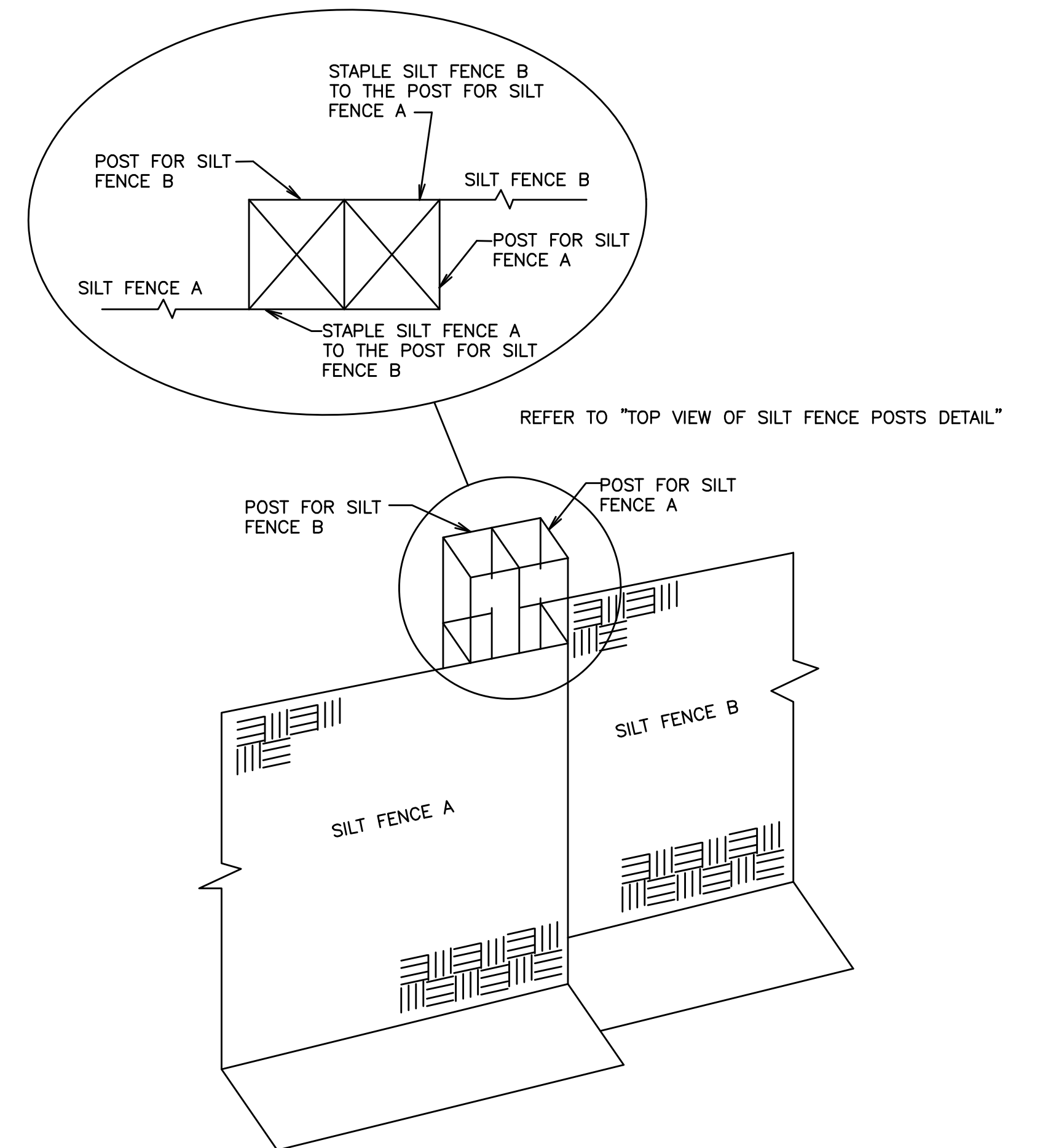

STRAW BALE BARRIER NOTES

INSTALLATION REQUIREMENTS

- STRAW BALE BARRIERS SHALL BE INSTALLED PRIOR TO ANY LAND DISTURBING ACTIVITIES.
- BALES SHALL CONSIST OF APPROXIMATELY 5 CUBIC FEET OF CERTIFIED WEED FREE HAY OR STRAW AND WEIGH NOT LESS THAN 35 POUNDS.
- BALES ARE TO BE PLACED IN A SINGLE ROW WITH THE END OF THE BALES TIGHTLY ABUTTING ONE ANOTHER
- EACH BALE IS TO BE SECURELY ANCHORED WITH AT LEAST TWO STAKES AND THE FIRST STAKE IS TO BE DRIVEN TOWARD THE PREVIOUSLY LAID BALE TO FORCE THE BALES TOGETHER.
- STAKES ARE TO BE A MINIMUM OF 42 INCHES LONG. METAL STAKES SHALL BE STANDARD "T" OR "U" TYPE WITH MINIMUM WEIGHT OF 1.33 POUNDS PER LINEAR FOOT. WOOD STAKES SHALL HAVE A MINIMUM DIAMETER OR CROSS SECTION DIMENSION OF 2 INCHES.
- BALES ARE TO BE BOUND WITH EITHER WIRE OR STRING AND ORIENTED SUCH THAT THE BINDINGS ARE AROUND OF SIDES AND NOT ALONG THE TOPS AND BOTTOMS OF THE BALE.
- GAPS BETWEEN BALES ARE TO BE CHINKED (FILLED BY WEDGING) WITH STRAW OR THE SAME MATERIAL OF THE BALE.
- END BALES ARE TO BE EXTENDED UPSLOPE SO THE TRAPPED RUNOFF CANNOT FLOW AROUND THE ENDS OF THE BARRIER.

MAINTENANCE REQUIREMENTS

- CONTRACTOR SHALL INSPECT STRAW BALE BARRIERS IMMEDIATELY AFTER EACH RAINFALL AT LEAST DAILY DURING PROLONGED RAINFALL, AND WEEKLY DURING PERIODS OF NO RAINFALL.
- DAMAGED OR INEFFECTIVE BARRIERS SHALL PROMPTLY BE REPAIRED, REPLACING BALES IF NECESSARY, AND UNENTRENCHED BALES NEED TO BE REPAIRED WITH COMPACTED BACKFILL MATERIAL.
- SEDIMENT SHALL BE REMOVED FROM BEHIND STRAY BALE BARRIERS WHEN IT ACCUMULATES TO APPROXIMATELY 1/2 THE HEIGHT OF THE BARRIER.
- STRAW BALE BARRIERS SHALL BE REMOVED WHEN ADEQUATE VEGETATIVE COVER IS ATTAINED AS APPROVED BY THE CITY.

Computer File Information

Creation Date: 4-25-17	Initials: CMD
Last Modification Date:	Initials:
Full Path & Drawing File Name:	
Acad Ver. 2014	Scale: Units: Feet

Index of Revisions

Stantec
Stantec Consulting Inc.
5725 MARK DABLING BLVD
Suite 190
Colorado Springs, CO 80919
Tel. (719) 594-4535
Fax.
www.stantec.com

**GARDENS AT NORTH CAREFREE
GRADING AND EROSION DETAILS**

Designer: CD	Structure Numbers
Detailer: MB	
Sheet Subset:	

Project No./Code
187608744

V:\52876\active\187608744-Mule Deer\CAD\Sheets\Construction Drawings\29 - Grading And Erosion Details.dwg 2019/11/22 9:46 AM By: Pearce, Taylor

GRADING AND EROSION CONTROL DETAILS AND NOTES

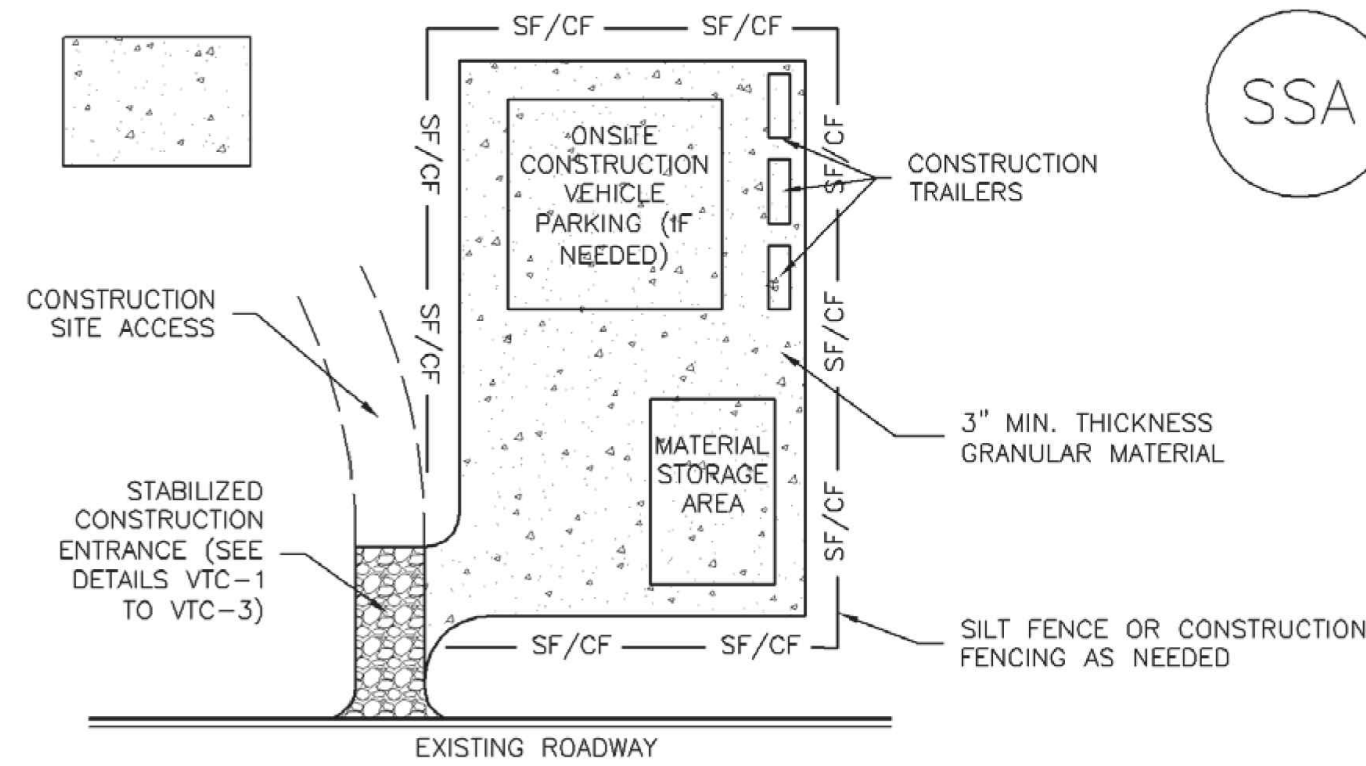

SSA-1. STABILIZED STAGING AREA

STABILIZED STAGING AREA INSTALLATION NOTES

- SEE PLAN VIEW FOR:
 - LOCATION OF STAGING AREA(S).
 - CONTRACTOR MAY ADJUST LOCATION AND SIZE OF STAGING AREA WITH APPROVAL FROM THE LOCAL JURISDICTION.
- STABILIZED STAGING AREA SHOULD BE APPROPRIATE FOR THE NEEDS OF THE SITE. OVERSIZING RESULTS IN A LARGER AREA TO STABILIZE FOLLOWING CONSTRUCTION.
- STAGING AREA SHALL BE STABILIZED PRIOR TO OTHER OPERATIONS ON THE SITE.
- THE STABILIZED STAGING AREA SHALL CONSIST OF A MINIMUM 3" THICK GRANULAR MATERIAL.
- UNLESS OTHERWISE SPECIFIED BY LOCAL JURISDICTION, ROCK SHALL CONSIST OF DOT SECT. #703, AASHTO #3 COARSE AGGREGATE OR 6" (MINUS) ROCK.
- ADDITIONAL PERIMETER BMPs MAY BE REQUIRED INCLUDING BUT NOT LIMITED TO SILT FENCE AND CONSTRUCTION FENCING.

STABILIZED STAGING AREA MAINTENANCE NOTES

- INSPECT BMPs EACH WORKDAY, AND MAINTAIN THEM IN EFFECTIVE OPERATING CONDITION. MAINTENANCE OF BMPs SHOULD BE PROACTIVE, NOT REACTIVE. INSPECT BMPs AS SOON AS POSSIBLE (AND ALWAYS WITHIN 24 HOURS) FOLLOWING A STORM THAT CAUSES SURFACE EROSION, AND PERFORM NECESSARY MAINTENANCE.
- FREQUENT OBSERVATIONS AND MAINTENANCE ARE NECESSARY TO MAINTAIN BMPs IN EFFECTIVE OPERATING CONDITION. INSPECTIONS AND CORRECTIVE MEASURES SHOULD BE DOCUMENTED THOROUGHLY.
- WHERE BMPs HAVE FAILED, REPAIR OR REPLACEMENT SHOULD BE INITIATED UPON DISCOVERY OF THE FAILURE.
- ROCK SHALL BE REAPPLIED OR REGRADED AS NECESSARY IF RUTTING OCCURS OR UNDERLYING SUBGRADE BECOMES EXPOSED.

SSA

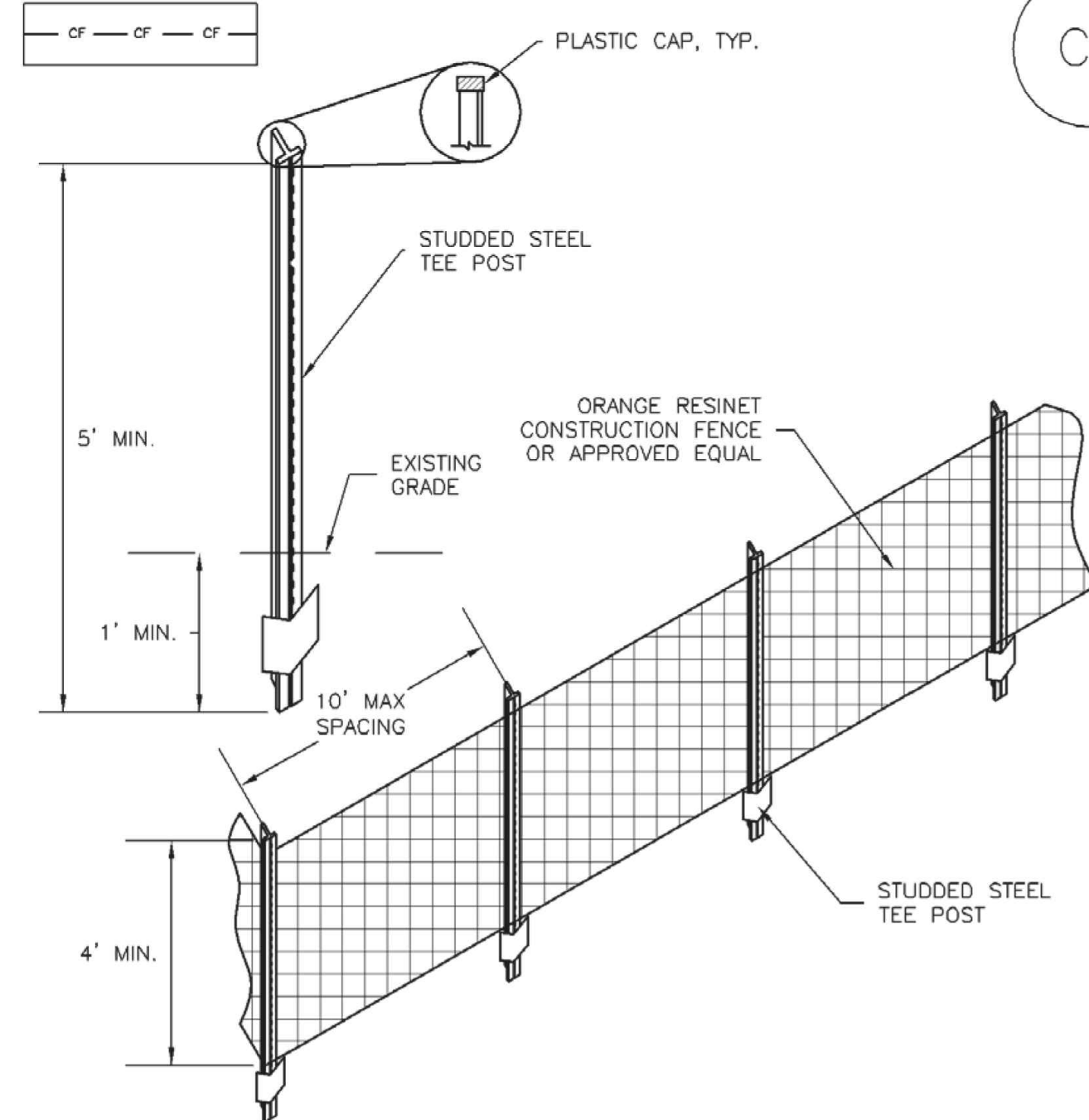

CF-1. PLASTIC MESH CONSTRUCTION FENCE

CONSTRUCTION FENCE INSTALLATION NOTES

- SEE PLAN VIEW FOR:
 - LOCATION OF CONSTRUCTION FENCE.
- CONSTRUCTION FENCE SHOWN SHALL BE INSTALLED PRIOR TO ANY LAND DISTURBING ACTIVITIES.
- CONSTRUCTION FENCE SHALL BE COMPOSED OF ORANGE, CONTRACTOR-GRADE MATERIAL THAT IS AT LEAST 4' HIGH. METAL POSTS SHOULD HAVE A PLASTIC CAP FOR SAFETY.
- STUDDED STEEL TEE POSTS SHALL BE UTILIZED TO SUPPORT THE CONSTRUCTION FENCE. MAXIMUM SPACING FOR STEEL TEE POSTS SHALL BE 10'.
- CONSTRUCTION FENCE SHALL BE SECURELY FASTENED TO THE TOP, MIDDLE, AND BOTTOM OF EACH POST.

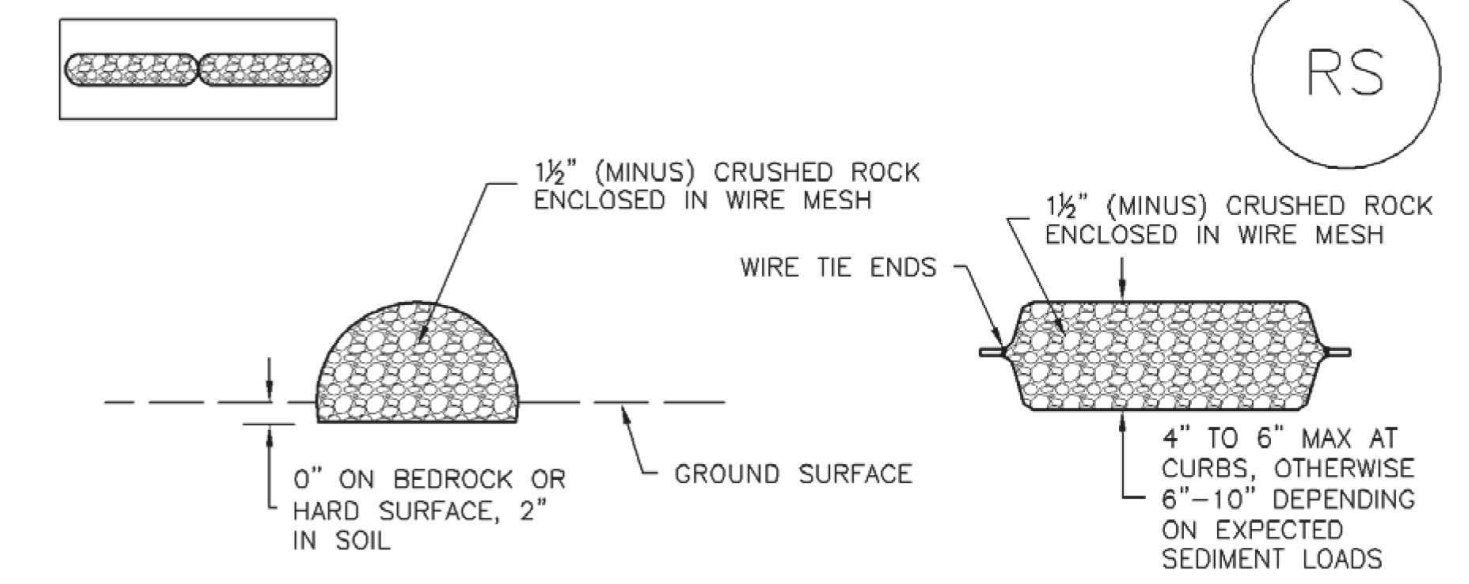

ROCK SOCK SECTION ROCK SOCK PLAN

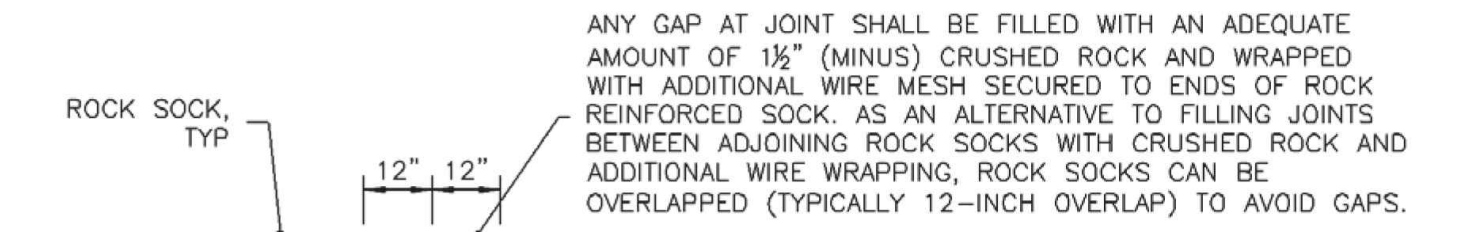

ROCK SOCK JOINTING

ROCK SOCK INSTALLATION NOTES

- SEE PLAN VIEW FOR:
 - LOCATION(S) OF ROCK SOCKS.
- CRUSHED ROCK SHALL BE 1½" (MINUS) IN SIZE WITH A FRACTURED FACE (ALL SIDES) AND SHALL COMPLY WITH GRADATION SHOWN ON THIS SHEET (1½" MINUS).
- WIRE MESH SHALL BE FABRICATED OF 10 GAGE POULTRY MESH, OR EQUIVALENT, WITH A MAXIMUM OPENING OF ½", RECOMMENDED MINIMUM ROLL WIDTH OF 48"
- WIRE MESH SHALL BE SECURED USING "HOG RINGS" OR WIRE TIES AT 6" CENTERS ALONG ALL JOINTS AND AT 2" CENTERS ON ENDS OF SOCKS.
- SOME MUNICIPALITIES MAY ALLOW THE USE OF FILTER FABRIC AS AN ALTERNATIVE TO WIRE MESH FOR THE ROCK ENCLOSURE.

GRADATION TABLE	
SIEVE SIZE	MASS PERCENT PASSING SQUARE MESH SIEVES
	NO. 4
2"	100
1½"	90 - 100
1"	20 - 55
¾"	0 - 15
⅝"	0 - 5

MATCHES SPECIFICATIONS FOR NO. 4 COARSE AGGREGATE FOR CONCRETE PER AASHTO M43. ALL ROCK SHALL BE FRACTURED FACE, ALL SIDES.

RS-1. ROCK SOCK PERIMETER CONTROL

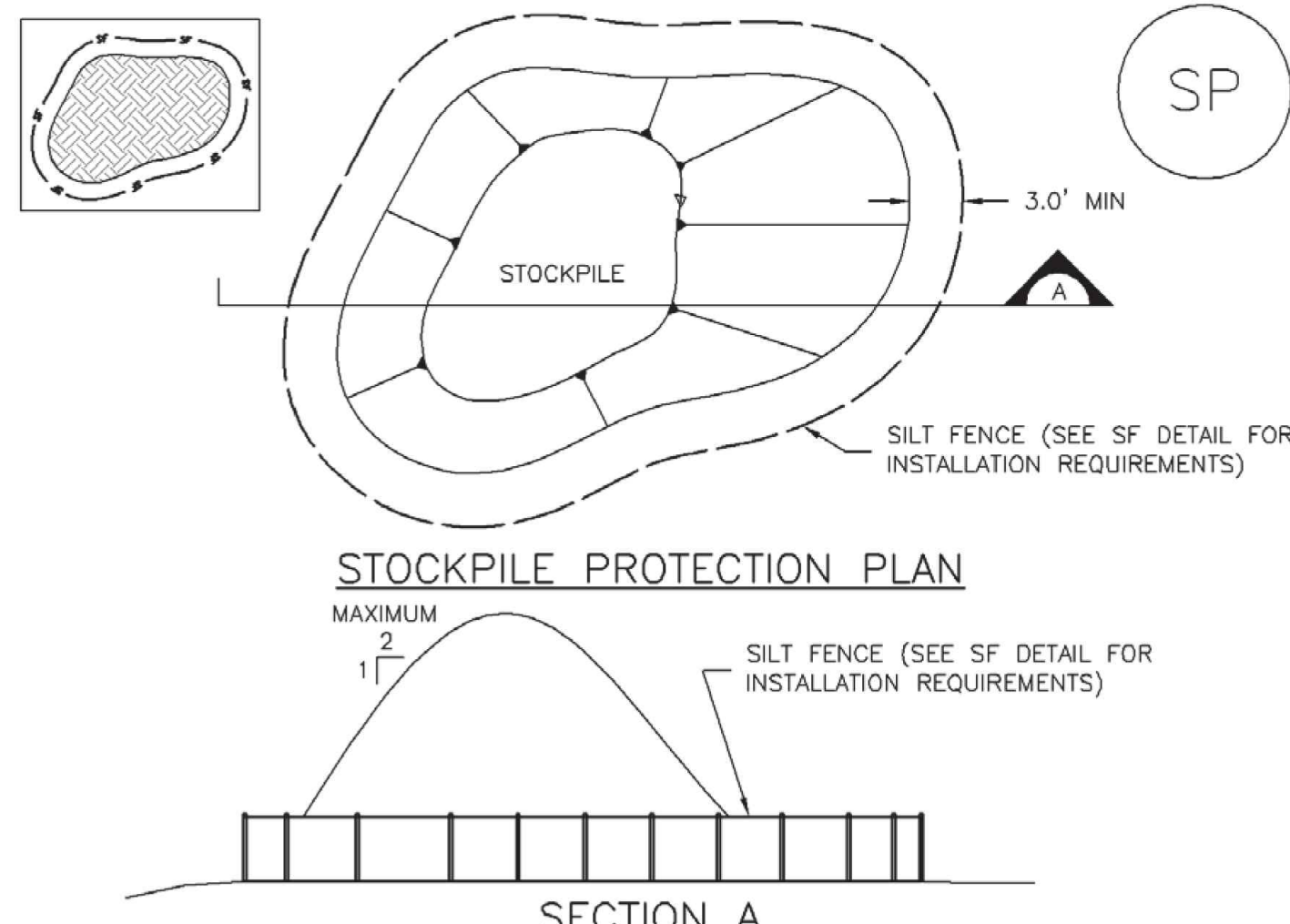

SP-1. STOCKPILE PROTECTION

STOCKPILE PROTECTION INSTALLATION NOTES

- SEE PLAN VIEW FOR:
 - LOCATION OF STOCKPILES.
 - TYPE OF STOCKPILE PROTECTION.
- INSTALL PERIMETER CONTROLS IN ACCORDANCE WITH THEIR RESPECTIVE DESIGN DETAILS. SILT FENCE IS SHOWN IN THE STOCKPILE PROTECTION DETAILS; HOWEVER, OTHER TYPES OF PERIMETER CONTROLS INCLUDING SEDIMENT CONTROL LOGS OR ROCK SOCKS MAY BE SUITABLE IN SOME CIRCUMSTANCES. CONSIDERATIONS FOR DETERMINING THE APPROPRIATE TYPE OF PERIMETER CONTROL FOR A STOCKPILE INCLUDE WHETHER THE STOCKPILE IS LOCATED ON A PERVIOUS OR IMPERVIOUS SURFACE, THE RELATIVE HEIGHTS OF THE PERIMETER CONTROL AND STOCKPILE, THE ABILITY OF THE PERIMETER CONTROL TO CONTAIN THE STOCKPILE WITHOUT FAILING IN THE EVENT THAT MATERIAL FROM THE STOCKPILE SHIFTS OR SLUMPS AGAINST THE PERIMETER, AND OTHER FACTORS.
- STABILIZE THE STOCKPILE SURFACE WITH SURFACE ROUGHENING, TEMPORARY SEEDING AND MULCHING, EROSION CONTROL BLANKETS, OR SOIL BINDERS. SOILS STOCKPILED FOR AN EXTENDED PERIOD (TYPICALLY FOR MORE THAN 60 DAYS) SHOULD BE SEEDED AND MULCHED WITH A TEMPORARY GRASS COVER ONCE THE STOCKPILE IS PLACED (TYPICALLY WITHIN 14 DAYS). USE OF MULCH ONLY OR A SOIL BINDER IS ACCEPTABLE IF THE STOCKPILE WILL BE IN PLACE FOR A MORE LIMITED TIME PERIOD (TYPICALLY 30-60 DAYS).
- FOR TEMPORARY STOCKPILES ON THE INTERIOR PORTION OF A CONSTRUCTION SITE, WHERE OTHER DOWNGRADE CONTROLS, INCLUDING PERIMETER CONTROL, ARE IN PLACE, STOCKPILE PERIMETER CONTROLS MAY NOT BE REQUIRED.

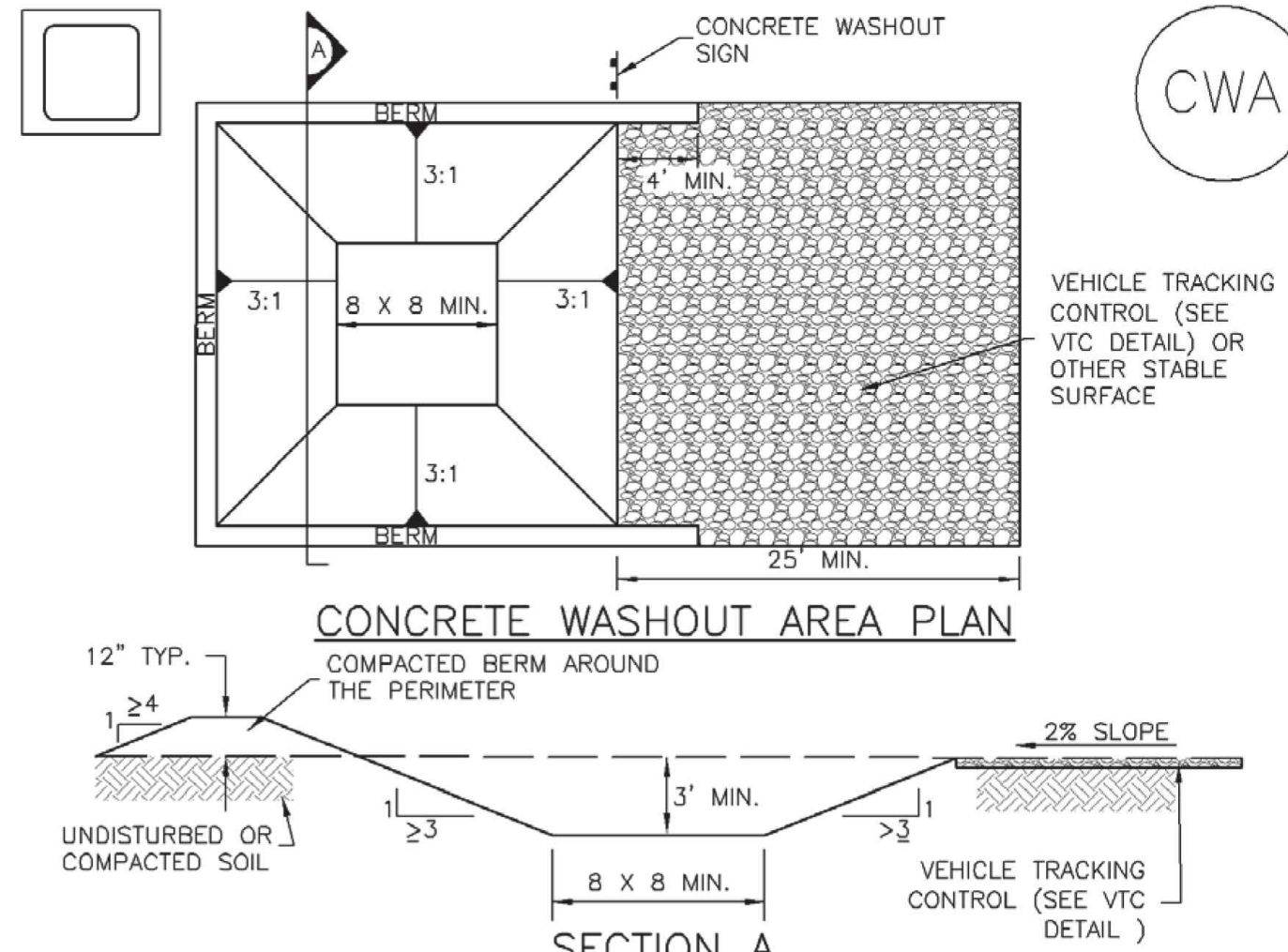

CWA-1. CONCRETE WASHOUT AREA

CWA INSTALLATION NOTES

- SEE PLAN VIEW FOR:
 - CWA INSTALLATION LOCATION.
- DO NOT LOCATE AN UNLINED CWA WITHIN 400' OF ANY NATURAL DRAINAGE PATHWAY OR WATERBODY. DO NOT LOCATE WITHIN 1,000' OF ANY WELLS OR DRINKING WATER SOURCES. IF SITE CONSTRAINTS MAKE THIS INFEASIBLE, OR IF HIGHLY PERMEABLE SOILS EXIST ON SITE, THE CWA MUST BE INSTALLED WITH AN IMPERMEABLE LINER (16 MIL MIN. THICKNESS) OR SURFACE STORAGE ALTERNATIVES USING PREFABRICATED CONCRETE WASHOUT DEVICES OR A LINED ABOVE GROUND STORAGE ARE SHOULD BE USED.
- THE CWA SHALL BE INSTALLED PRIOR TO CONCRETE PLACEMENT ON SITE.
- CWA SHALL INCLUDE A FLAT SUBSURFACE PIT THAT IS AT LEAST 8' BY 8' SLOPES LEADING OUT OF THE SUBSURFACE PIT SHALL BE 3:1 OR FLATTER. THE PIT SHALL BE AT LEAST 3' DEEP.
- BERM SURROUNDING SIDES AND BACK OF THE CWA SHALL HAVE MINIMUM HEIGHT OF 1'.
- VEHICLE TRACKING PAD SHALL BE SLOPED 2% TOWARDS THE CWA.
- SIGNS SHALL BE PLACED AT THE CONSTRUCTION ENTRANCE, AT THE CWA, AND ELSEWHERE AS NECESSARY TO CLEARLY INDICATE THE LOCATION OF THE CWA TO OPERATORS OF CONCRETE TRUCKS AND PUMP RIGS.
- USE EXCAVATED MATERIAL FOR PERIMETER BERM CONSTRUCTION.

V:\52876\active\187608744-Mule Deer\CAD\Sheets\Construction Drawings\29 - Grading And Erosion Details.dwg 2019/11/22 9:46 AM By: Pearce, Taylor

Computer File Information	
Creation Date: 4-25-17	Initials: CMD
Last Modification Date:	Initials:
Full Path & Drawing File Name:	
Acad Ver. 2014	Scale: Units: Feet

Index of Revisions	

Stantec
Stantec Consulting Inc.
5725 MARK DABLING BLVD
Suite 190
Colorado Springs, CO 80919
Tel. (719) 594-4535
Fax.
www.stantec.com

GARDENS AT NORTH CAREFREE GRADING AND EROSION DETAILS	
Designer: CD	Structure Numbers
Detailer: MB	
Sheet Subset:	

Project No./Code
187608744
SHEET 30 OF 34

GRADING AND EROSION CONTROL DETAILS AND NOTES

TS

PS

Seeding dates for the highest success probability of perennial species along the Front Range are generally in the spring from April through early May and in the fall after the first of September until the ground freezes. If the area is irrigated, seeding may occur in summer months, as well. See Table TS/PS-3 for appropriate seeding dates.

Table TS/PS-1. Minimum Drill Seeding Rates for Various Temporary Annual Grasses

Species ^a (Common name)	Growth Season ^b	Pounds of Pure Live Seed (PLS)/acre ^c	Planting Depth (inches)
1. Oats	Cool	35 - 50	1 - 2
2. Spring wheat	Cool	25 - 35	1 - 2
3. Spring barley	Cool	25 - 35	1 - 2
4. Annual ryegrass	Cool	10 - 15	½
5. Millet	Warm	3 - 15	½ - ¾
6. Sudangrass	Warm	5-10	½ - ¾
7. Sorghum	Warm	5-10	½ - ¾
8. Winter wheat	Cool	20-35	1 - 2
9. Winter barley	Cool	20-35	1 - 2
10. Winter rye	Cool	20-35	1 - 2
11. Triticale	Cool	25-40	1 - 2

^a Successful seeding of annual grass resulting in adequate plant growth will usually produce enough dead-plant residue to provide protection from wind and water erosion for an additional year. This assumes that the cover is not disturbed or mowed closer than 8 inches.

Hydraulic seeding may be substituted for drilling only where slopes are steeper than 3:1 or where access limitations exist. When hydraulic seeding is used, hydraulic mulching should be applied as a separate operation, when practical, to prevent the seeds from being encapsulated in the mulch.

^b See Table TS/PS-3 for seeding dates. Irrigation, if consistently applied, may extend the use of cool season species during the summer months.

^c Seeding rates should be doubled if seed is broadcast, or increased by 50 percent if done using a Brillion Drill or by hydraulic seeding.

Mulch

Cover seeded areas with mulch or an appropriate rolled erosion control product to promote establishment of vegetation. Anchor mulch by crimping, netting or use of a non-toxic tackifier. See the Mulching BMP Fact Sheet for additional guidance.

Maintenance and Removal

Monitor and observe seeded areas to identify areas of poor growth or areas that fail to germinate. Reseed and mulch these areas, as needed.

An area that has been permanently seeded should have a good stand of vegetation within one growing season if irrigated and within three growing seasons without irrigation in Colorado. Reseed portions of the site that fail to germinate or remain bare after the first growing season.

Seeded areas may require irrigation, particularly during extended dry periods. Targeted weed control may also be necessary.

Protect seeded areas from construction equipment and vehicle access.

Table TS/PS-2. Minimum Drill Seeding Rates for Perennial Grasses

Common ^a Name	Botanical Name	Growth Season ^b	Growth Form	Seeds/ Pound	Pounds of PLS/acre
Alkali Soil Seed Mix					
Alkali sacaton	<i>Sporobolus airoides</i>	Cool	Bunch	1,750,000	0.25
Basin wildrye	<i>Elymus cinereus</i>	Cool	Bunch	165,000	2.5
Sodar streambank wheatgrass	<i>Agropyron riparium 'Sodar'</i>	Cool	Sod	170,000	2.5
Jose tall wheatgrass	<i>Agropyron elongatum 'Jose'</i>	Cool	Bunch	79,000	7.0
Arriba western wheatgrass	<i>Agropyron smithii 'Arriba'</i>	Cool	Sod	110,000	5.5
Total					17.75
Fertile Loamy Soil Seed Mix					
Ephriam crested wheatgrass	<i>Agropyron cristatum 'Ephriam'</i>	Cool	Sod	175,000	2.0
Dural hard fescue	<i>Festuca ovina 'duriuscula'</i>	Cool	Bunch	565,000	1.0
Lincoln smooth brome	<i>Bromus inermis leyss 'Lincoln'</i>	Cool	Sod	130,000	3.0
Sodar streambank wheatgrass	<i>Agropyron riparium 'Sodar'</i>	Cool	Sod	170,000	2.5
Arriba western wheatgrass	<i>Agropyron smithii 'Arriba'</i>	Cool	Sod	110,000	7.0
Total					15.5
High Water Table Soil Seed Mix					
Meadow foxtail	<i>Alopecurus pratensis</i>	Cool	Sod	900,000	0.5
Redtop	<i>Agrostis alba</i>	Warm	Open sod	5,000,000	0.25
Reed canarygrass	<i>Phalaris arundinacea</i>	Cool	Sod	68,000	0.5
Lincoln smooth brome	<i>Bromus inermis leyss 'Lincoln'</i>	Cool	Sod	130,000	3.0
Pathfinder switchgrass	<i>Panicum virgatum 'Pathfinder'</i>	Warm	Sod	389,000	1.0
Alkar tall wheatgrass	<i>Agropyron elongatum 'Alkar'</i>	Cool	Bunch	79,000	5.5
Total					10.75
Transition Turf Seed Mix^c					
Ruebens Canadian bluegrass	<i>Poa compressa 'Ruebens'</i>	Cool	Sod	2,500,000	0.5
Dural hard fescue	<i>Festuca ovina 'duriuscula'</i>	Cool	Bunch	565,000	1.0
Citation perennial ryegrass	<i>Lolium perenne 'Citation'</i>	Cool	Sod	247,000	3.0
Lincoln smooth brome	<i>Bromus inermis leyss 'Lincoln'</i>	Cool	Sod	130,000	3.0
Total					7.5

Table TS/PS-2. Minimum Drill Seeding Rates for Perennial Grasses (cont.)

Common Name	Botanical Name	Growth Season ^b	Growth Form	Seeds/ Pound	Pounds of PLS/acre
Sandy Soil Seed Mix					
Blue grama	<i>Bouteloua gracilis</i>	Warm	Sod-forming bunchgrass	825,000	0.5
Camper little bluestem	<i>Schizachyrium scoparium 'Camper'</i>	Warm	Bunch	240,000	1.0
Prairie sandreed	<i>Calamovilfa longifolia</i>	Warm	Open sod	274,000	1.0
Sand dropseed	<i>Sporobolus cryptandrus</i>	Cool	Bunch	5,298,000	0.25
Vaughn sideoats grama	<i>Bouteloua curtipendula 'Vaughn'</i>	Warm	Sod	191,000	2.0
Arriba western wheatgrass	<i>Agropyron smithii 'Arriba'</i>	Cool	Sod	110,000	5.5
Total					10.25
Heavy Clay, Rocky Foothill Seed Mix					
Ephriam crested wheatgrass ^d	<i>Agropyron cristatum 'Ephriam'</i>	Cool	Sod	175,000	1.5
Oahe Intermediate wheatgrass	<i>Agropyron intermedium 'Oahe'</i>	Cool	Sod	115,000	5.5
Vaughn sideoats grama ^e	<i>Bouteloua curtipendula 'Vaughn'</i>	Warm	Sod	191,000	2.0
Lincoln smooth brome	<i>Bromus inermis leyss 'Lincoln'</i>	Cool	Sod	130,000	3.0
Arriba western wheatgrass	<i>Agropyron smithii 'Arriba'</i>	Cool	Sod	110,000	5.5
Total					17.5

^a All of the above seeding mixes and rates are based on drill seeding followed by crimped straw mulch. These rates should be doubled if seed is broadcast and should be increased by 50 percent if the seeding is done using a Brillion Drill or is applied through hydraulic seeding. Hydraulic seeding may be substituted for drilling only where slopes are steeper than 3:1. If hydraulic seeding is used, hydraulic mulching should be done as a separate operation.

^b See Table TS/PS-3 for seeding dates.

^c If site is to be irrigated, the transition turf seed rates should be doubled.

^d Crested wheatgrass should not be used on slopes steeper than 6H to 1V.

^e Can substitute 0.5 lbs PLS of blue grama for the 2.0 lbs PLS of Vaughn sideoats grama.

Table TS/PS-3. Seeding Dates for Annual and Perennial Grasses

Seeding Dates	Annual Grasses (Numbers in table reference species in Table TS/PS-1)		Perennial Grasses	
	Warm	Cool	Warm	Cool
January 1–March 15			✓	✓
March 16–April 30	4	1,2,3	✓	✓
May 1–May 15	4		✓	
May 16–June 30	4,5,6,7			
July 1–July 15	5,6,7			
July 16–August 31				
September 1–September 30		8,9,10,11		
October 1–December 31			✓	✓

TEMPORARY AND PERMANENT SEEDING

V:\52876\active\187608744\Mule Deer\CAD\Sheets\Construction Drawings\29 - Grading And Erosion Details.dwg 2019/11/22 9:46 AM By: Pearce, Taylor

Computer File Information	
Creation Date: 4-25-17	Initials: CMD
Last Modification Date:	Initials:
Full Path & Drawing File Name:	
Acad Ver. 2014	Scale: Units: Feet

Index of Revisions	

Stantec
Stantec Consulting Inc.
5725 MARK DABLING BLVD
Suite 190
Colorado Springs, CO 80919
Tel. (719) 594-4535
Fax.
www.stantec.com

GARDENS AT NORTH CAREFREE GRADING AND EROSION DETAILS		
Designer: CD	Structure Numbers	
Detailer: MB		
Sheet Subset:		

Project No./Code
187608744
SHEET 31 OF 34

GRADING AND EROSION CONTROL DETAILS AND NOTES

TABLE SB-1. SIZING INFORMATION FOR STANDARD SEDIMENT BASIN

Upstream Drainage Area (rounded to nearest acre), (ac)	Basin Bottom Width (W), (ft)	Spillway Crest Length (CL), (ft)	Hole Diameter (HD), (in)
1	12 1/2	2	9 3/2
2	21	3	1 3/16
3	28	5	9 1/2
4	33 1/2	6	2 1/6
5	38 1/2	9	2 3/2
6	43	11	2 3/2
7	47 1/2	12	2 3/2
8	51	13	7 8
9	55	15	1 9/16
10	58 1/2	16	3 1/2
11	61	18	1
12	64	19	1 1/6
13	67 1/2	21	1 1/6
14	70 1/2	22	1 3/16
15	73 1/2		

SEDIMENT BASIN INSTALLATION NOTES

- SEE PLAN VIEW FOR:
 - LOCATION OF SEDIMENT BASIN.
 - TYPE OF BASIN (STANDARD BASIN OR NONSTANDARD BASIN).
 - FOR STANDARD BASIN, BOTTOM WIDTH W, CREST LENGTH CL, AND HOLE DIAMETER, HD.
 - FOR NONSTANDARD BASIN, SEE CONSTRUCTION DRAWINGS FOR DESIGN OF BASIN INCLUDING RISER HEIGHT H, NUMBER OF COLUMNS N, HOLE DIAMETER HD AND PIPE DIAMETER D.
- FOR STANDARD BASIN, BOTTOM DIMENSION MAY BE MODIFIED AS LONG AS BOTTOM AREA IS NOT REDUCED.
- SEDIMENT BASINS SHALL BE INSTALLED PRIOR TO ANY OTHER LAND-DISTURBING ACTIVITY THAT RELIES ON ON BASINS AS AS A STORMWATER CONTROL.
- EMBANKMENT MATERIAL SHALL CONSIST OF SOIL FREE OF DEBRIS, ORGANIC MATERIAL, AND ROCKS OR CONCRETE GREATER THAN 3 INCHES AND SHALL HAVE A MINIMUM OF 15 PERCENT BY WEIGHT PASSING THE NO. 200 SIEVE.
- EMBANKMENT MATERIAL SHALL BE COMPACTED TO AT LEAST 95 PERCENT OF MAXIMUM DENSITY IN ACCORDANCE WITH ASTM D698.
- PIPE SCH 40 OR GREATER SHALL BE USED.
- THE DETAILS SHOWN ON THESE SHEETS PERTAIN TO STANDARD SEDIMENT BASIN(S) FOR DRAINAGE AREAS LESS THAN 15 ACRES. SEE CONSTRUCTION DRAWINGS FOR EMBANKMENT, STORAGE VOLUME, SPILLWAY, OUTLET, AND OUTLET PROTECTION DETAILS FOR ANY SEDIMENT BASIN(S) THAT HAVE BEEN INDIVIDUALLY DESIGNED FOR DRAINAGE AREAS LARGER THAN 15 ACRES.

SEDIMENT BASIN MAINTENANCE NOTES

- INSPECT BMPs EACH WORKDAY, AND MAINTAIN THEM IN EFFECTIVE OPERATING CONDITION. MAINTENANCE OF BMPs SHOULD BE PROACTIVE, NOT REACTIVE. INSPECT BMPs AS SOON AS POSSIBLE (AND ALWAYS WITHIN 24 HOURS) FOLLOWING A STORM THAT CAUSES SURFACE EROSION, AND PERFORM NECESSARY MAINTENANCE.
- FREQUENT OBSERVATIONS AND MAINTENANCE ARE NECESSARY TO MAINTAIN BMPs IN EFFECTIVE OPERATING CONDITION. INSPECTIONS AND CORRECTIVE MEASURES SHOULD BE DOCUMENTED THOROUGHLY.
- WHERE BMPs HAVE FAILED, REPAIR OR REPLACEMENT SHOULD BE INITIATED UPON DISCOVERY OF THE FAILURE.
- SEDIMENT ACCUMULATED IN BASIN SHALL BE REMOVED AS NEEDED TO MAINTAIN BMP EFFECTIVENESS, TYPICALLY WHEN SEDIMENT DEPTH REACHES ONE FOOT (I.E., TWO FEET BELOW THE SPILLWAY CREST).
- SEDIMENT BASINS ARE TO REMAIN IN PLACE UNTIL THE UPSTREAM DISTURBED AREA IS STABILIZED AND GRASS COVER IS ACCEPTED BY THE LOCAL JURISDICTION.
- WHEN SEDIMENT BASINS ARE REMOVED, ALL DISTURBED AREAS SHALL BE COVERED WITH TOPSOIL, SEEDED AND MULCHED OR OTHERWISE STABILIZED AS APPROVED BY LOCAL JURISDICTION.

(DETAILS ADAPTED FROM DOUGLAS COUNTY, COLORADO)

NOTE: MANY JURISDICTIONS HAVE BMP DETAILS THAT VARY FROM UDFCD STANDARD DETAILS. CONSULT WITH LOCAL JURISDICTIONS AS TO WHICH DETAIL SHOULD BE USED WHEN DIFFERENCES ARE NOTED.

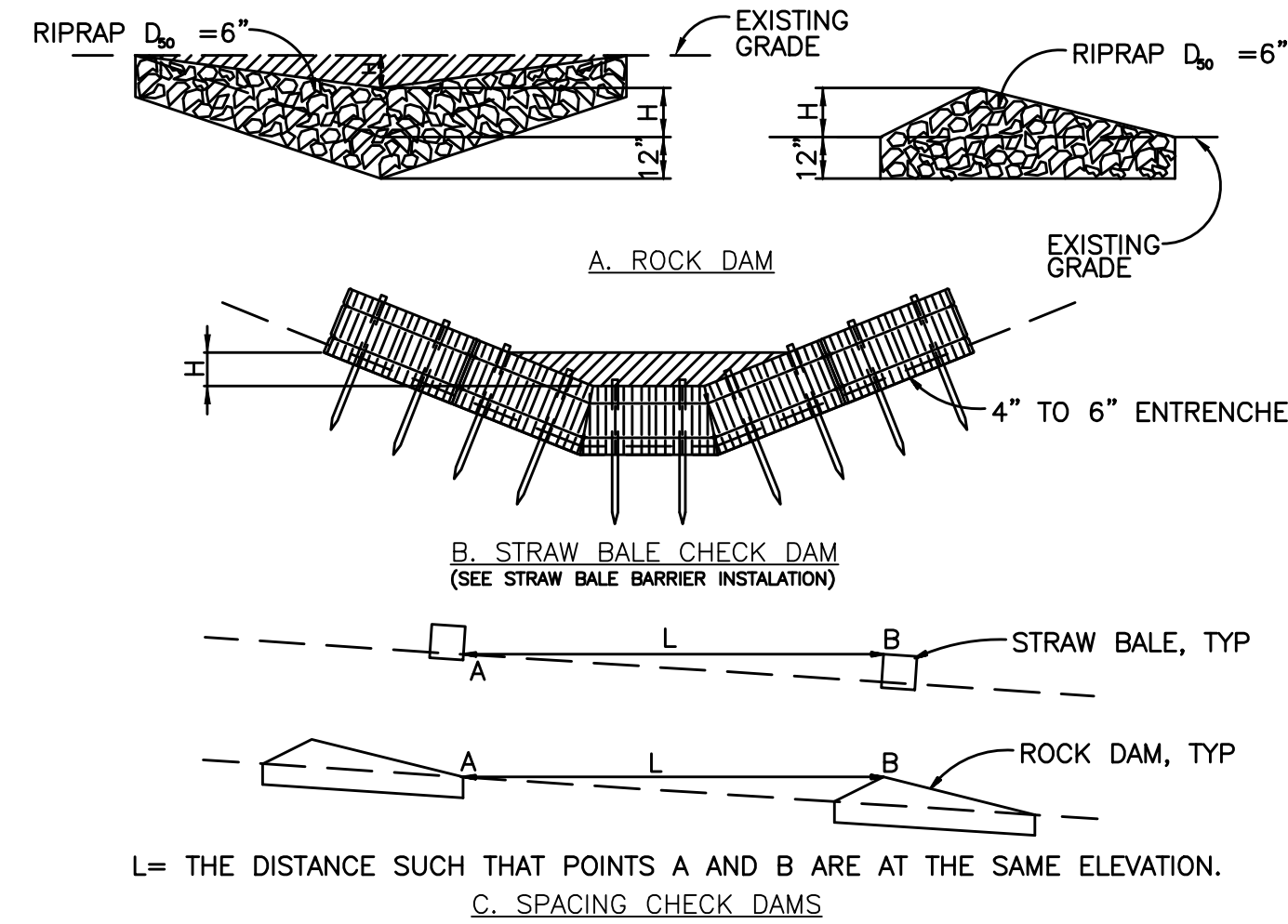
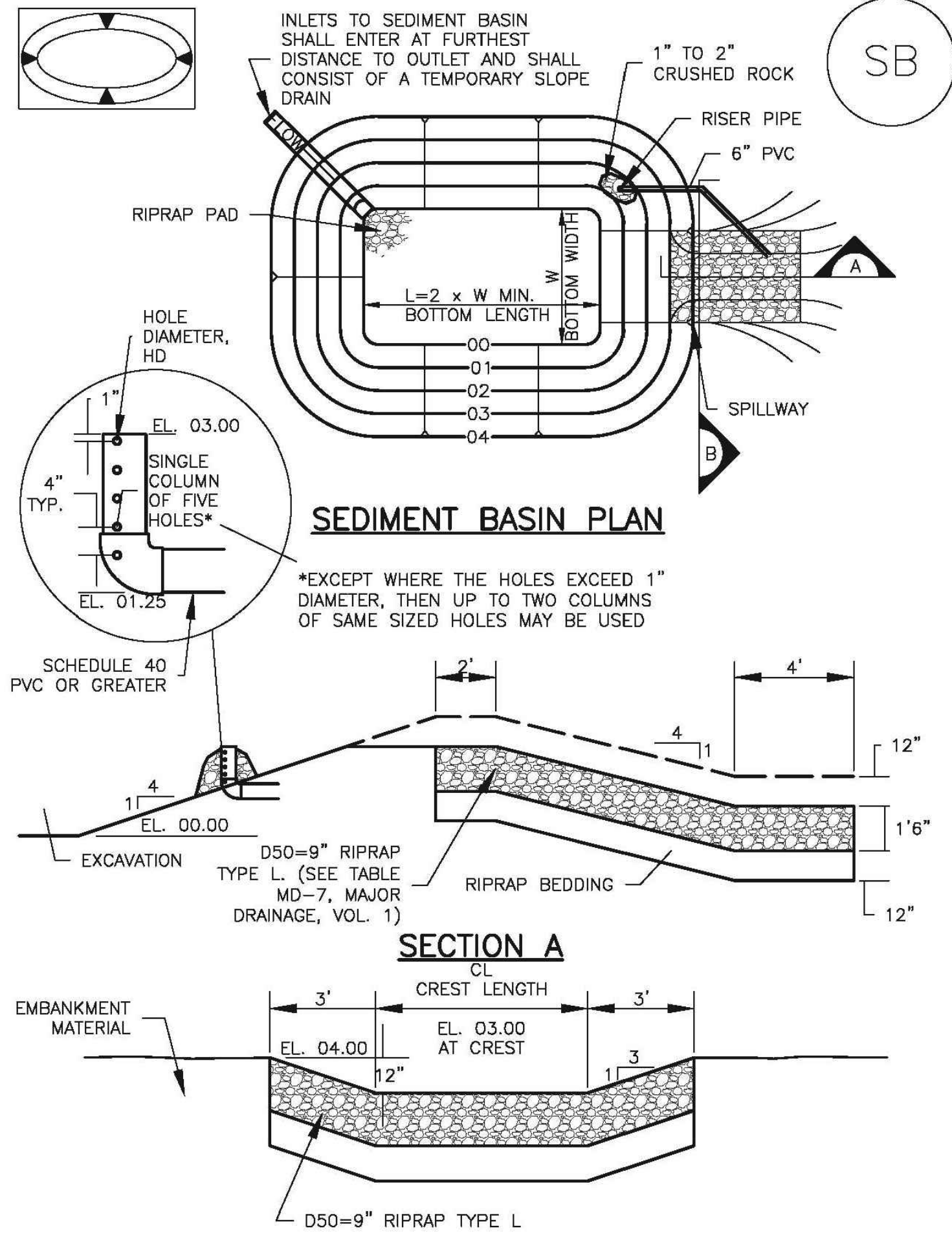

CHECK DAM

NTS CHECK DAM NOTES

INSTALLATION REQUIREMENTS

- STRAW BALES USED AS CHECK DAMS ARE TO MEET THE REQUIREMENTS STATED IN FIGURE SBB-2.
- THE "H" DIMENSION SHALL BE SELECTED TO PROVIDE WEIR FLOW CONVEYANCE FOR 2-YEAR FLOW OR GREATER.

MAINTENANCE REQUIREMENTS

- REGULAR INSPECTIONS ARE TO BE MADE OF ALL CHECK DAMS, ESPECIALLY AFTER STORM EVENTS.
- REPLACE STONE AS NECESSARY TO MAINTAIN THE CORRECT HEIGHT OF THE DAM.
- ACCUMULATED SEDIMENT AND DEBRIS IS TO BE REMOVED FROM BEHIND THE DAMS AFTER EACH STORM OR WHEN 1/2 OF THE ORIGINAL HEIGHT OF THE DAM IS REACHED.
- CHECK DAMS ARE TO REMAIN IN PLACE AND OPERATIONAL UNTIL THE DRAINAGE AREA AND CHANNEL ARE PERMANENTLY STABILIZED.
- WHEN CHECK DAMS ARE REMOVED THE CHANNEL LINING OR VEGETATION IS TO BE RESTORED.

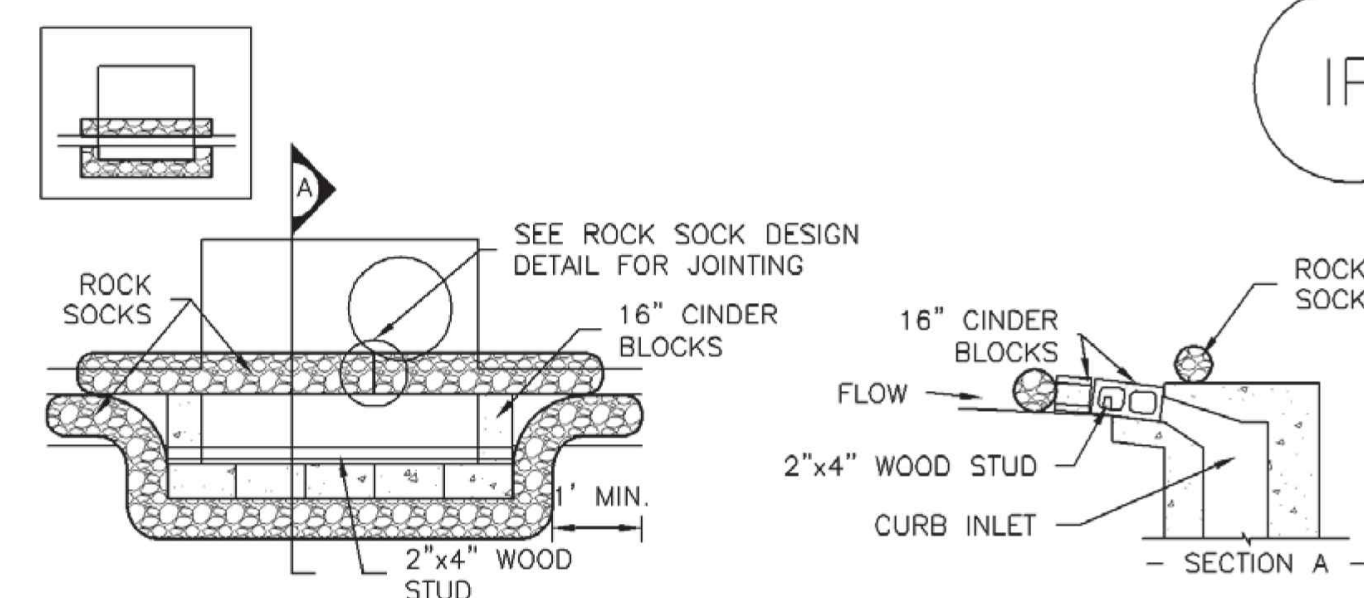

IP-1. BLOCK AND ROCK SOCK SUMP OR ON GRADE INLET PROTECTION

BLOCK AND CURB SOCK INLET PROTECTION INSTALLATION NOTES

- SEE ROCK SOCK DESIGN DETAIL FOR INSTALLATION REQUIREMENTS.
- CONCRETE "CINDER" BLOCKS SHALL BE LAID ON THEIR SIDES AROUND THE INLET IN A SINGLE ROW, ABUTTING ONE ANOTHER WITH THE OPEN END FACING AWAY FROM THE CURB.
- GRAVEL BAGS SHALL BE PLACED AROUND CONCRETE BLOCKS, CLOSELY ABUTTING ONE ANOTHER AND JOINTED TOGETHER IN ACCORDANCE WITH ROCK SOCK DESIGN DETAIL.

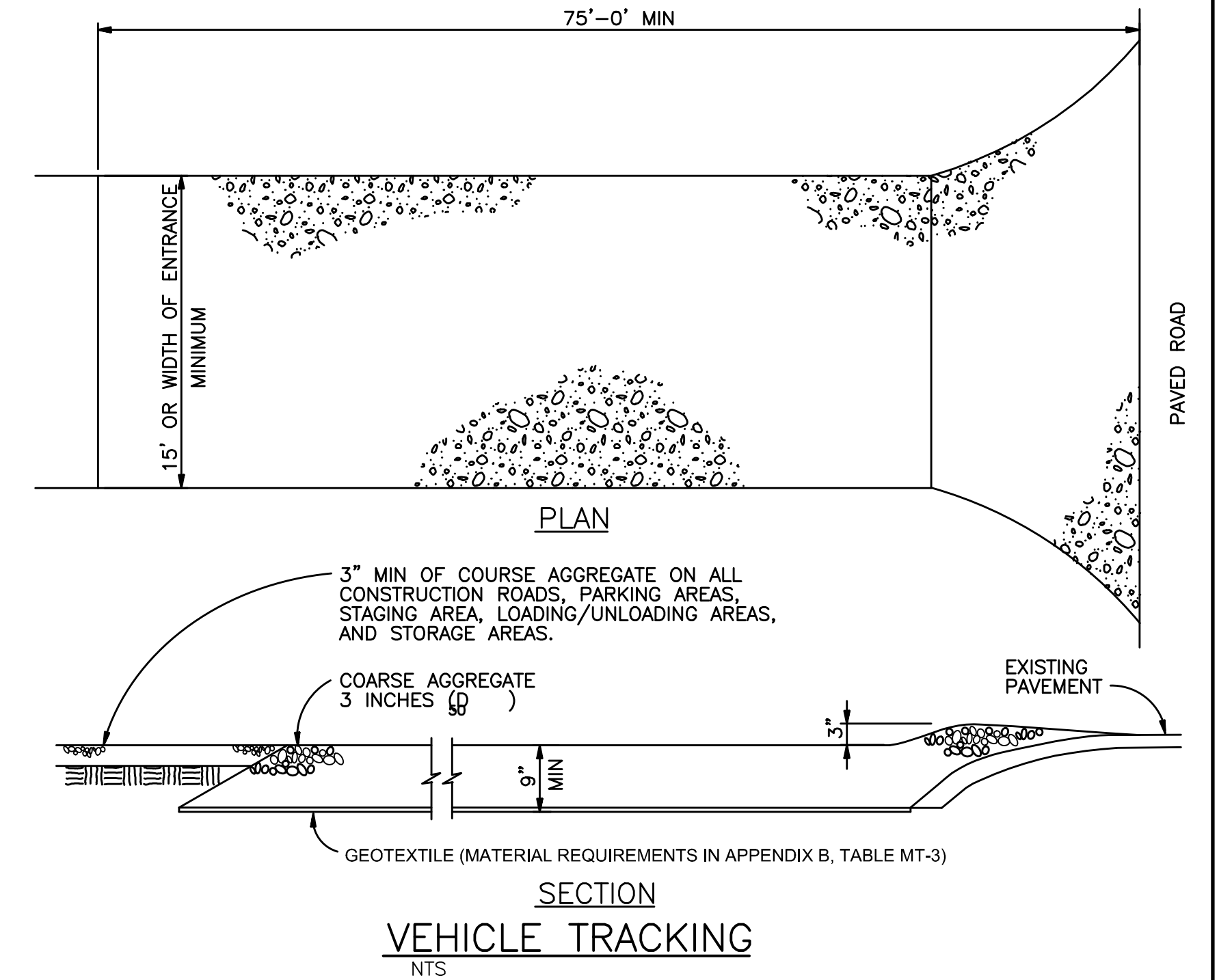

VEHICLE TRACKING NOTES

INSTALLATION REQUIREMENTS

- ALL ENTRANCES TO THE CONSTRUCTION SITE ARE TO BE STABILIZED PRIOR TO CONSTRUCTION BEGINNING.
- CONSTRUCTION ENTRANCES ARE TO BE BUILT WITH AN APRON TO ALLOW FOR TURNING TRAFFIC, BUT SHOULD NOT BE BUILT OVER EXISTING PAVEMENT EXCEPT FOR A SLIGHT OVERLAP.
- AREAS TO BE STABILIZED ARE TO BE PROPERLY GRADED AND COMPACTED PRIOR TO LAYING DOWN GEOTEXTILE AND STONE.
- CONSTRUCTION ROADS, PARKING AREAS, LOADING/UNLOADING ZONES, STORAGE AREAS, AND STAGING AREAS ARE TO BE STABILIZED.
- CONSTRUCTION ROADS ARE TO BE BUILT TO CONFORM TO SITE GRADES, BUT SHOULD NOT HAVE SIDE SLOPES OR ROAD GRADES THAT ARE EXCESSIVELY STEEP.

MAINTENANCE REQUIREMENTS

- REGULAR INSPECTIONS ARE TO BE MADE OF ALL STABILIZED AREAS, ESPECIALLY AFTER STORM EVENTS.
- STONES ARE TO BE REAPPLIED PERIODICALLY AND WHEN REPAIR IS NECESSARY.
- SEDIMENT TRACKED ONTO PAVED ROADS IS TO BE REMOVED DAILY BY SHOVELING OR SWEEPING. SEDIMENT IS NOT TO BE WASHED DOWN STORM SEWER DRAINS.
- STORM SEWER INLET PROTECTION IS TO BE IN PLACE, INSPECTED, AND CLEANED IF NECESSARY.
- OTHER ASSOCIATED SEDIMENT CONTROL MEASURES ARE TO BE INSPECTED TO ENSURE GOOD WORKING CONDITION.

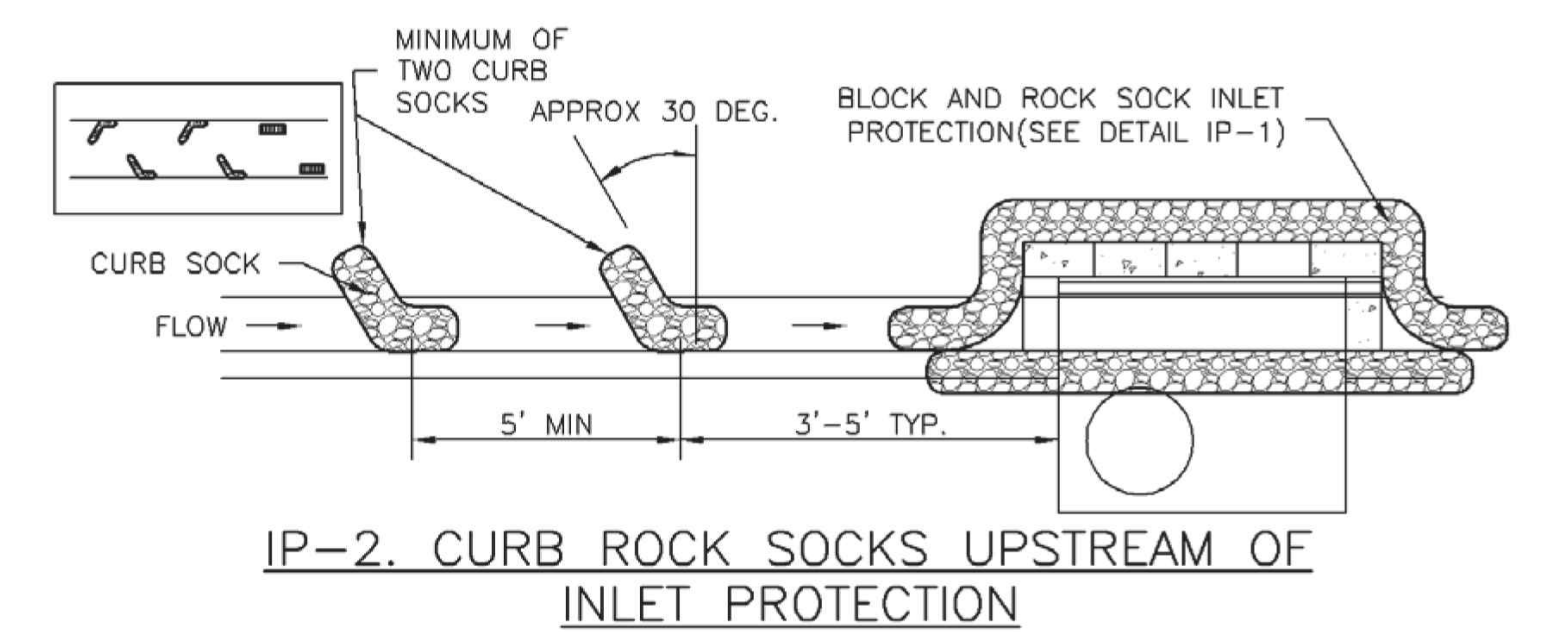

IP-2. CURB ROCK SOCKS UPSTREAM OF INLET PROTECTION

CURB ROCK SOCK INLET PROTECTION INSTALLATION NOTES

- SEE ROCK SOCK DESIGN DETAIL INSTALLATION REQUIREMENTS.
- PLACEMENT OF THE SOCK SHALL BE APPROXIMATELY 30 DEGREES FROM PERPENDICULAR IN THE OPPOSITE DIRECTION OF FLOW.
- SOCKS ARE TO BE FLUSH WITH THE CURB AND SPACED A MINIMUM OF 5 FEET APART.
- AT LEAST TWO CURB SOCKS IN SERIES ARE REQUIRED UPSTREAM OF ON-GRADE INLETS.

Computer File Information

Creation Date: 4-25-17 Initials: CMD
 Last Modification Date: Initials:
 Full Path & Drawing File Name:
 Acad Ver. 2014 Scale: Units: Feet

Index of Revisions

NO.	DATE	DESCRIPTION

Stantec
 Stantec Consulting Inc.
 5725 MARK DABLING BLVD
 Suite 190
 Colorado Springs, CO 80919
 Tel. (719) 594-4535
 Fax.
 www.stantec.com

**GARDENS AT NORTH CAREFREE
 GRADING AND EROSION DETAILS**

Designer: CD
 Detailer: MB
 Sheet Subst:

Structure
 Numbers

Project No./Code
 187608744

SHEET 32 OF 34

V:\52876\active\187608744-Mule Deer\CAD\Sheets\Construction Drawings\30 - Master Utility Plan.dwg
 2019/12/19 1:33 PM By: Pearce, Taylor

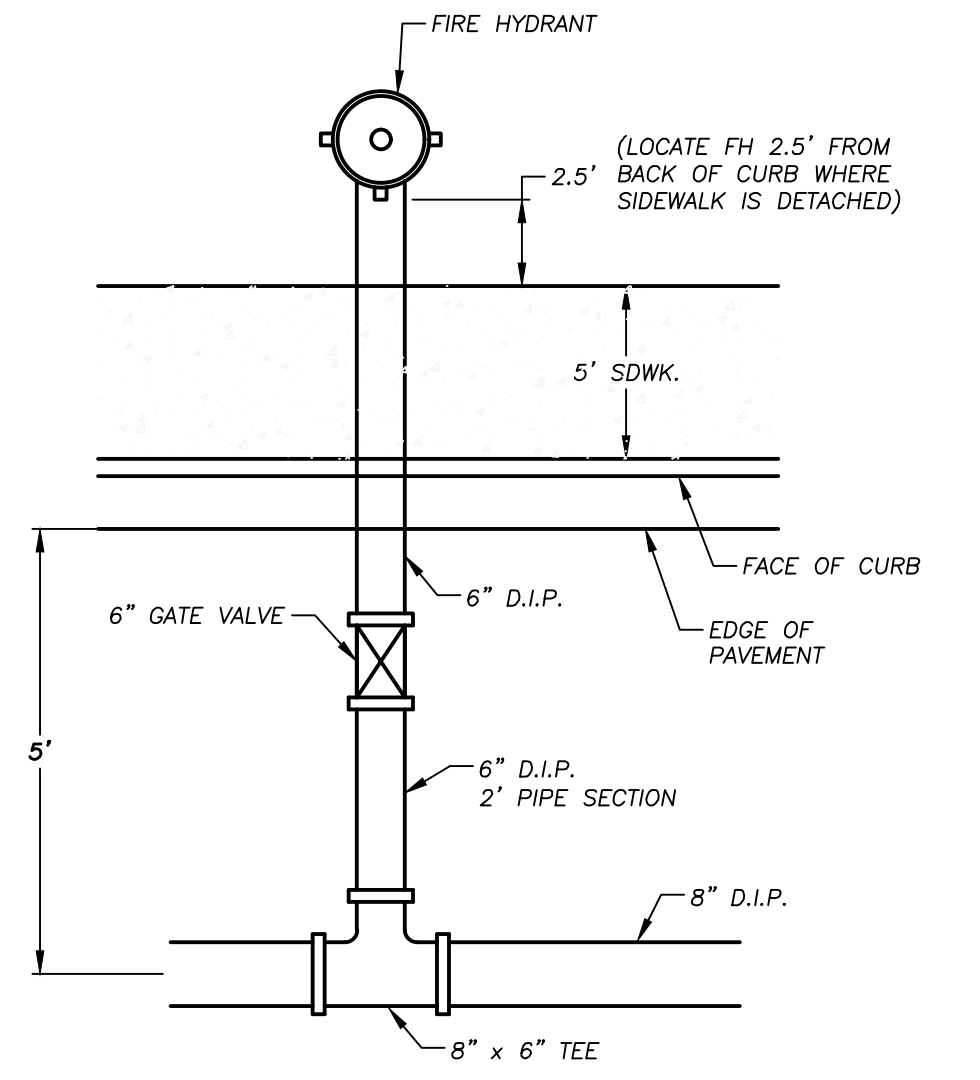
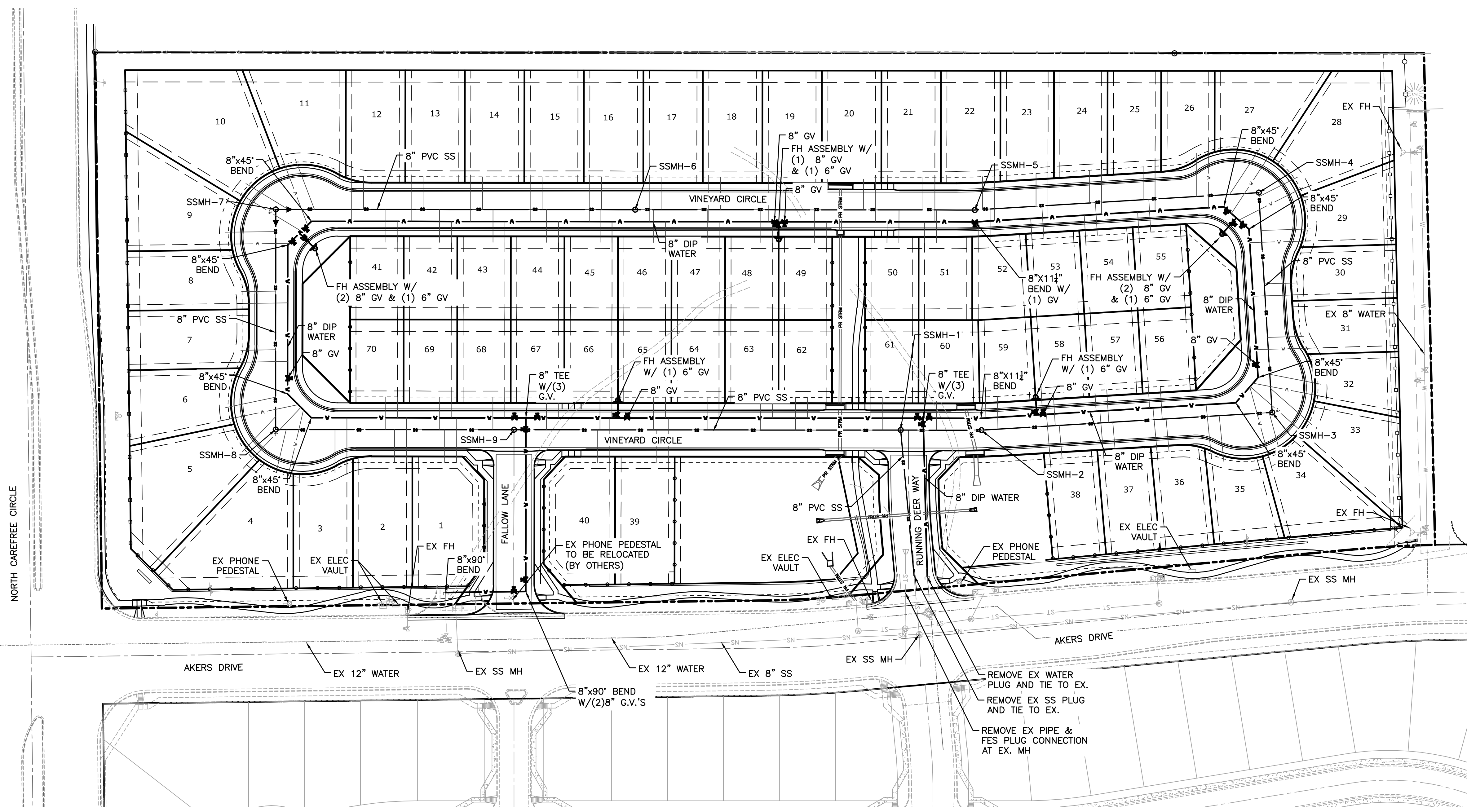

FIRE HYDRANT CONFIGURATION
 SCALE : N.T.S.

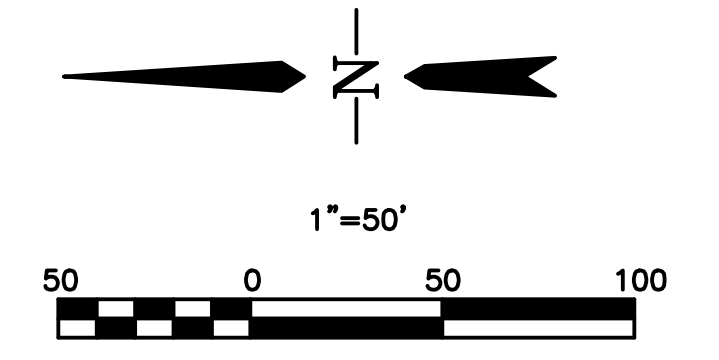

LEGEND

- EX WATER
- EX SAN SEWER
- EX GAS
- EX STORM SEWER
- EX WATER VALVE
- EX FIRE HYDRANT
- EX SANITARY SEWER MH
- PR WATER LINE
- PR SANITARY SEWER
- PR STORM SEWER
- PR SANITARY SEWER MANHOLE
- PR STORM SEWER MANHOLE
- PR WATER VALVE
- PR FIRE HYDRANT

- NOTES:**
- MECHANICAL MEANS SHOULD NOT BE USED TO ACCOMPLISH CURVED PIPE ALIGNMENTS WITH THE WASTEWATER PVC PIPE. IT IS THE INTENT THAT THIS SHOULD BE ACCOMPLISHED MANUALLY IN THE TRENCH BY THE INSTALLATION PERSONNEL. THE CURVE SHOULD BE ACCOMPLISHED BY BENDING THE PIPE RATHER THAN DEFLECTING THE JOINTS. OVER-BENDING OF JOINTS SHOULD BE AVOIDED. WATERLINE DUCTILE IRON PIPE DEFLECTIONS TO BE ACCOMPLISHED IN ACCORDANCE WITH SECURITY WATER DISTRICT STANDARDS.
 - THE MINIMUM RADIUS OF CURVATURE FOR 8-INCH PVC DIAMETER PIPE IS 200 FEET.
 - ALL WATER SERVICES TO BE 1" BLUE HDPE PIPE, ASTM D2737; AWWA C901, DR 9, 250 PSI PRESSURE RATING ACCOMPANIED BY A TRACER WIRE (SEE SHEET 2 CHEROKEE METRO UTILITY GENERAL NOTE # 13).

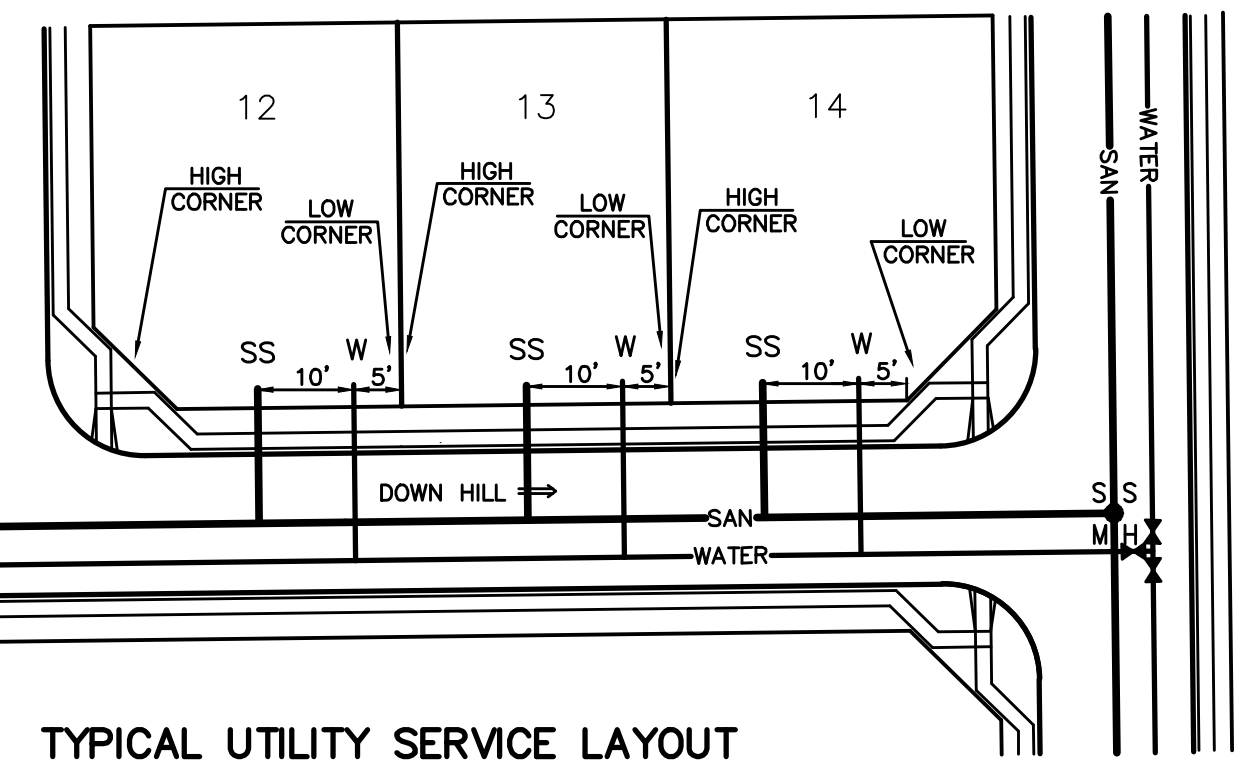

TYPICAL UTILITY SERVICE LAYOUT
 DEVELOPER TO COORDINATE LOCATION OF ELECTRIC, PHONE AND CABLE.

Computer File Information	
Creation Date: 4-25-17	Initials: CMD
Last Modification Date:	Initials:
Full Path & Drawing File Name:	
Acad Ver. 2014	Scale: Units: Feet

Index of Revisions	

Stantec
 Stantec Consulting Inc.
 5725 MARK DABLING BLVD
 Suite 190
 Colorado Springs, CO 80919
 Tel. (719) 594-4535
 Fax.
 www.stantec.com

GARDENS AT NORTH CAREFREE MASTER UTILITY PLAN		
Designer: CD	Structure Numbers	
Detailer: MB		
Sheet Subst:		

Project No./Code
187608744
SHEET 33 OF 34

V:\52876\active\187608744-Mule Deer\CAD\Sheets\Construction Drawings\31 - Signing And Striping Plan.dwg
2019/11/22 9:55 AM By: Pearce, Taylor

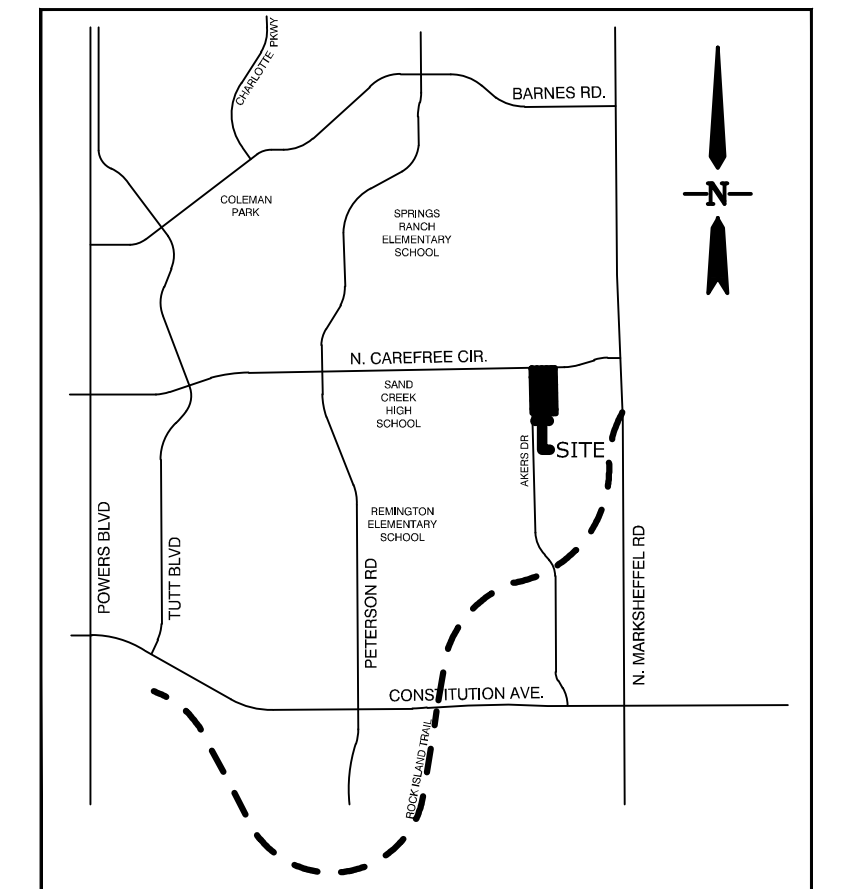
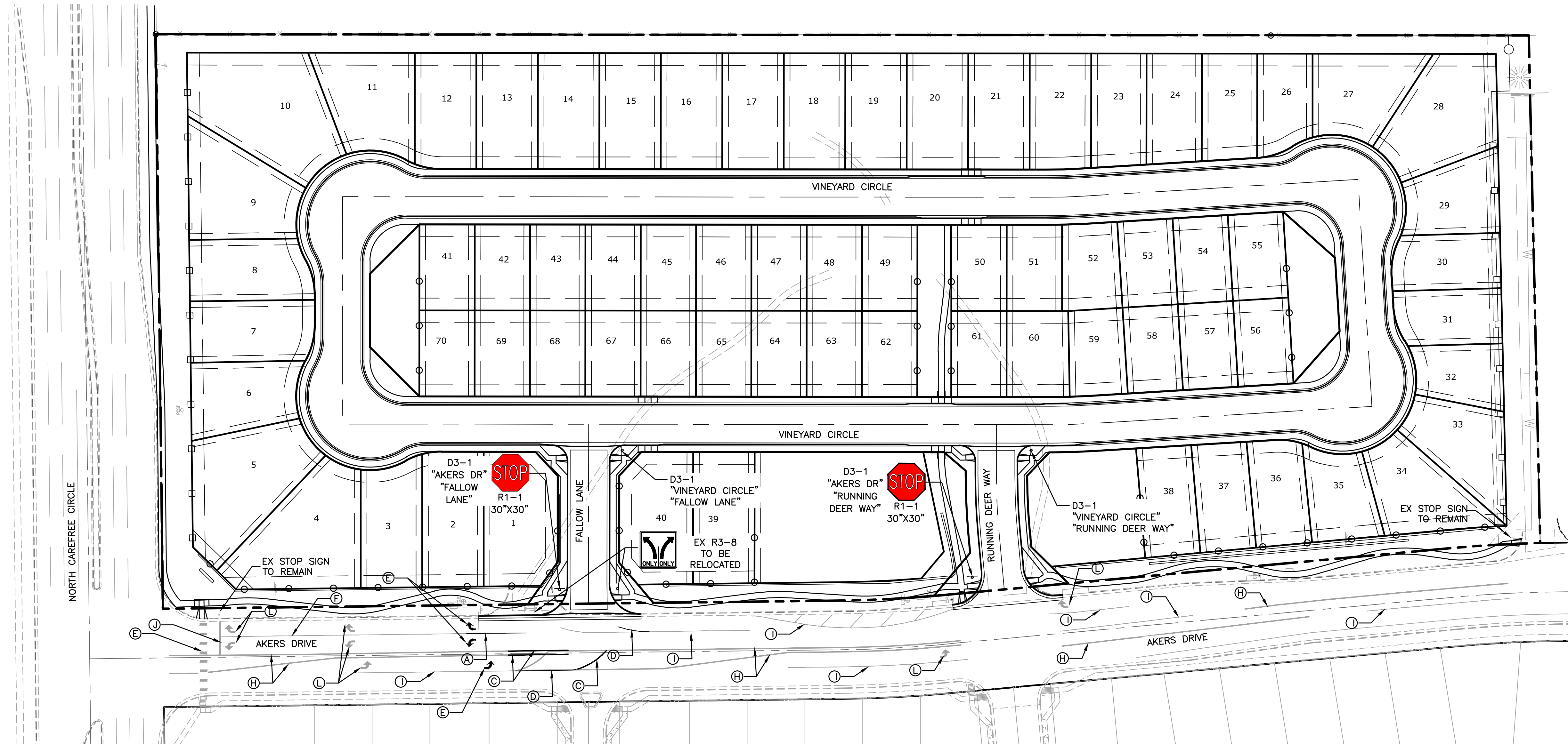

VICINITY MAP
N.T.S.

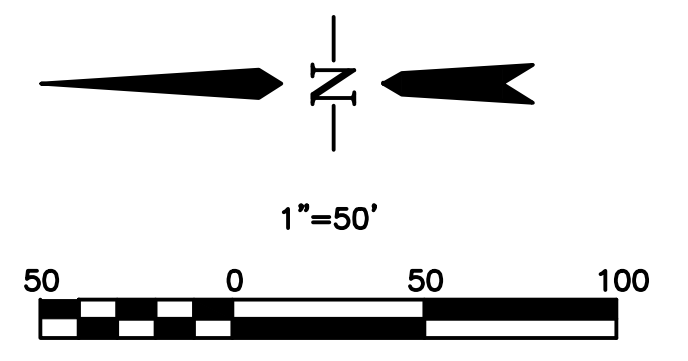

- LEGEND**
- A 4" WHITE EDGE LINE
 - B 4" YELLOW DASHED CENTERLINE
 - C 4" DOUBLE YELLOW CENTERLINE
 - D 8" WHITE CHANNELIZING LINE
 - E PREFORMED PLASTIC WHITE SYMBOL
 - F EX. 4" WHITE EDGE LINE
 - G EX. 4" YELLOW DASHED CENTERLINE
 - H EX. 4" DOUBLE YELLOW CENTERLINE
 - I EX. 8" WHITE CHANNELIZING LINE
 - J EX. 12" WHITE STOP BAR
 - K EX. 24" WHITE CROSSWALK
 - L EX. PREFORMED PLASTIC WHITE SYMBOL

- STRIPING AND SIGNAGE GENERAL NOTES:**
1. ALL SIGNS AND PAVEMENT MARKINGS SHALL BE IN COMPLIANCE WITH THE CURRENT MANUAL ON UNIFORM TRAFFIC CONTROL DEVICES (MUTCD).
 2. REMOVAL OF EXISTING PAVEMENT MARKINGS SHALL BE ACCOMPLISHED BY A METHOD THAT DOES NOT MATERIALLY DAMAGE THE PAVEMENT. THE PAVEMENT MARKINGS SHALL BE REMOVED TO THE EXTENT THAT THEY WILL NOT BE VISIBLE UNDER DAY OR NIGHT CONDITIONS. AT NO TIME WILL IT BE ACCEPTABLE TO PAINT OVER EXISTING PAVEMENT MARKINGS.
 3. ANY DEVIATION FROM THE STRIPING AND SIGNING PLAN SHALL BE APPROVED BY EL PASO COUNTY PLANNING AND COMMUNITY DEVELOPMENT.
 4. ALL SIGNS SHOWN ON THE SIGNING AND STRIPING PLAN SHALL BE NEW SIGNS. EXISTING SIGNS MAY REMAIN OR BE REUSED IF THEY MEET CURRENT EL PASO COUNTY AND MUTCD STANDARDS.
 5. STREET NAME AND REGULATORY STOP SIGNS SHALL BE ON THE SAME POST AT INTERSECTIONS.
 6. ALL REMOVED SIGNS SHALL BE DISPOSED OF IN A PROPER MANNER BY THE CONTRACTOR.
 7. ALL STREET NAME SIGNS SHALL HAVE "D" SERIES LETTERS, WITH LOCAL ROADWAY SIGNS BEING 4" UPPER-LOWER CASE LETTERING ON 8" BLANK AND COLLECTOR ROADWAY SIGNS BEING 6" LETTERING, UPPER-LOWER CASE ON 12" BLANK, WITH 1/2" WHITE BORDER THAT IS NOT RECESSED.
 8. ALL TRAFFIC SIGNS SHALL HAVE A MINIMUM HIGH INTENSITY PRISMATIC GRADE SHEETING.
 9. ALL LOCAL RESIDENTIAL STREET SIGNS SHALL BE MOUNTED ON A 1.75" X 1.75" SQUARE TUBE SIGN POST AND STUB POST BASE. FOR OTHER APPLICATIONS, REFER TO THE CDOT STANDARD S-614-8 REGARDING USE OF THE P2 TUBULAR STEEL POST SLIPBASE DESIGN.
 10. ALL SIGNS SHALL BE SINGLE SHEET ALUMINUM WITH 0.100" MINIMUM THICKNESS.
 11. ALL LIMIT LINES/STOP LINES, CROSSWALK LINES, PAVEMENT LEGENDS, AND ARROWS SHALL BE A MINIMUM 125 MIL THICKNESS PREFORMED THERMOPLASTIC PAVEMENT MARKINGS WITH TAPERED LEADING EDGES PER CDOT STANDARD S-627-1. WORD AND SYMBOL MARKINGS SHALL BE THE NARROW TYPE. STOP BARS SHALL BE 24" IN WIDTH. CROSSWALKS LINES SHALL BE 12" WIDE AND 8' LONG PER CDOT S-627-1.
 12. ALL LONGITUDINAL LINES SHALL BE A MINIMUM 15MIL THICKNESS EPOXY PAINT. ALL NON-LOCAL RESIDENTIAL ROADWAYS SHALL INCLUDE BOTH RIGHT AND LEFT EDGE LINE STRIPING AND ANY ADDITIONAL STRIPING AS REQUIRED BY CDOT S-627-1.
 13. THE CONTRACTOR SHALL NOTIFY EL PASO COUNTY PLANNING AND COMMUNITY DEVELOPMENT (719) 520-6819 PRIOR TO AND UPON COMPLETION OF SIGNING AND STRIPING.
 14. THE CONTRACTOR SHALL OBTAIN A WORK IN THE RIGHT OF WAY PERMIT FROM THE EL PASO COUNTY DEPARTMENT OF PUBLIC WORKS PRIOR TO ANY SIGNAGE OR STRIPING WORK WITHIN AN EXISTING EL PASO COUNTY ROADWAY.

Computer File Information	
Creation Date: 4-25-17	Initials: CMD
Last Modification Date:	Initials:
Full Path & Drawing File Name:	
Acad Ver. 2014	Scale: Units: Feet

Index of Revisions	

Stantec
Stantec Consulting Inc.
5725 MARK DABLING BLVD
Suite 190
Colorado Springs, CO 80919
Tel. (719) 594-4535
Fax.
www.stantec.com

GARDENS AT NORTH CAREFREE SIGNING & STRIPING	
Designer: CD	Structure Numbers
Detailer: MB	
Sheet Subst:	

Project No./Code
187608744
SHEET 34 OF 34