

**ENGINEERING STUDY
for
THE GARDENS AT NORTH CARFREE
WATER SYSTEM IMPROVEMENTS**

Prepared For:

**Mule Deer Investments, LLC
2727 Glen Arbor Drive
Colorado Springs, CO 80920**

Prepared By:

Stantec

5725 Mark Dabling Boulevard, Suite 190
Colorado Springs, CO 80919

Project No. 187608744

August 14, 2019

***** CONTENTS *****

| | | |
|------------------|---|-----------|
| Section 1 | EXECUTIVE SUMMARY | 1 |
| Section 2 | INTRODUCTION | 2 |
| 2.1 | Purpose | 2 |
| 2.2 | Scope | 2 |
| Section 3 | EXISTING CONDITIONS | 3 |
| 3.1 | Description of Service Area | 3 |
| 3.2 | Land Use | 3 |
| 3.3 | Topography and Floodplains | 3 |
| 3.4 | Geology | 3 |
| 3.5 | Groundwater | 3 |
| 3.6 | Climate | 6 |
| 3.7 | Natural Hazards Analysis | 6 |
| 3.8 | Organizational Context | 6 |
| 3.9 | Water Facilities | 6 |
| 3.10 | Relationship to Neighboring Water and Wastewater Facility | 6 |
| 3.11 | Water Demand | 7 |
| Section 4 | DEVELOPED CONDITIONS | 9 |
| 4.1 | Land Use | 9 |
| 4.2 | Population and Employment | 9 |
| 4.3 | Water Demand | 10 |
| 4.4 | Water Supply | 11 |
| 4.5 | Water Quality | 11 |
| Section 5 | WATER SYSTEM IMPROVEMENTS | 13 |
| 5.1 | General | 13 |
| 5.2 | Groundwater Wells | 13 |
| 5.3 | Treatment | 15 |
| 5.4 | Storage | 15 |
| 5.5 | Distribution | 15 |
| 5.6 | Other Costs and Gains | 16 |
| 5.7 | Rates and Charges | 16 |

******* APPENDICES *******

| | |
|------------|---------------------------------------|
| Appendix A | Cherokee Metropolitan District Report |
| Appendix B | District Letter of Commitment |
| Appendix C | Water Supply Summary |

******* LIST OF FIGURES *******

| | |
|----------|---|
| Figure 1 | Vicinity Map |
| Figure 2 | 1-Mile Radius Map |
| Figure 3 | The Gardens at North Carefree System Improvements |

Section 1
EXECUTIVE SUMMARY

This report presents the results of the engineering study for Water System Improvements serving The Gardens at North Carefree Development, a proposed development within the Hilltop Sketch Plan located due south of North Carefree Circle and due east of Akers Drive in El Paso County, Colorado.

The average annual water demand for The Gardens at North Carefree is estimated to be 21.7 acre-feet of water per year. This water will be delivered by the existing Cherokee Metropolitan District distribution system with extensions of that system as necessary.

To meet Drinking Water Standards both water suppliers' filter and disinfected source water prior to storage and have met Colorado Department of Health and Environment Drinking Water Standards.

The Cherokee Metropolitan District PWSID (Potable Water System Identification Number) is CO0121125.

Section 2 INTRODUCTION

2.1 Purpose

The purpose of this report is to present water system improvements recommended to serve The Gardens at North Carefree, a land development project located in El Paso County. It is also intended to serve as a guideline for the ensuing design of recommended improvements.

2.2 Scope

The scope of this report includes:

1. The definition of the service areas as well as identification of significant physical and environmental characteristics and constraints;
2. An analysis of available data to determine existing and to project future water supplies, demands and quality;
3. A description of legal, institutional and managerial arrangements that ensure adequate control of the proposed improvements; and,
4. A preliminary recommendation for a selected supply, treatment, pumping and transmission alternatives.

Section 3 EXISTING CONDITIONS

3.1 Description of the Service Area

The Gardens at North Carefree development consists of approximately 11.64 acres with a mixture of residential and open space uses and is located due south of North Carefree Circle and due east of Akers Drive within the East Half of Section 29, Township 13 South, Range 65 West.

Property west south and north of the site is currently being served by the Cherokee Metropolitan District for both water and sewer.

3.2 Land Use

The Gardens at North Carefree development is located in El Paso County on the eastern edge of the City of Colorado Springs urban development. Vacant land can be found east of the site. Most of the vacant land has been through City or County planning processes for development.

3.3 Topography and Floodplains

The topography of the service area is typical of a high desert, short grass prairie with primarily relatively flat slopes generally ranging from 2% to 4%. However, slopes in the 6% to 10% range can be found along the eastern boundary. The service area drains generally west to Akers Drive where existing water and sewer stubs are located.

The Flood Insurance Rate Map (FIRM No. 08041C0539-F dated 3/17/99) indicates that there is no floodplain in the vicinity of the proposed site.

3.4 Geology

The site is composed of a single soil type. From the NRCS report in Appendix A, the site falls into the following soil type:

97 – Truckton sandy loam (3-9%) – Type A Soil

Hydrologic soil groups are based on estimates of runoff potential. Soils are assigned to one of four groups according to the rate of water infiltration when the soils are not protected by vegetation, are thoroughly wet, and receive precipitation from long-duration storms. Group A soil is defined by:

Group A. Soils having a high infiltration rate (low runoff potential) when thoroughly wet. These consist mainly of deep, well drained to excessively drained sands or gravelly sands. These soils have a high rate of water transmission.

3.5 Groundwater

No shallow ground water has been identified on site.

GARDENS AT NORTH CAREFREE BOUNDARY

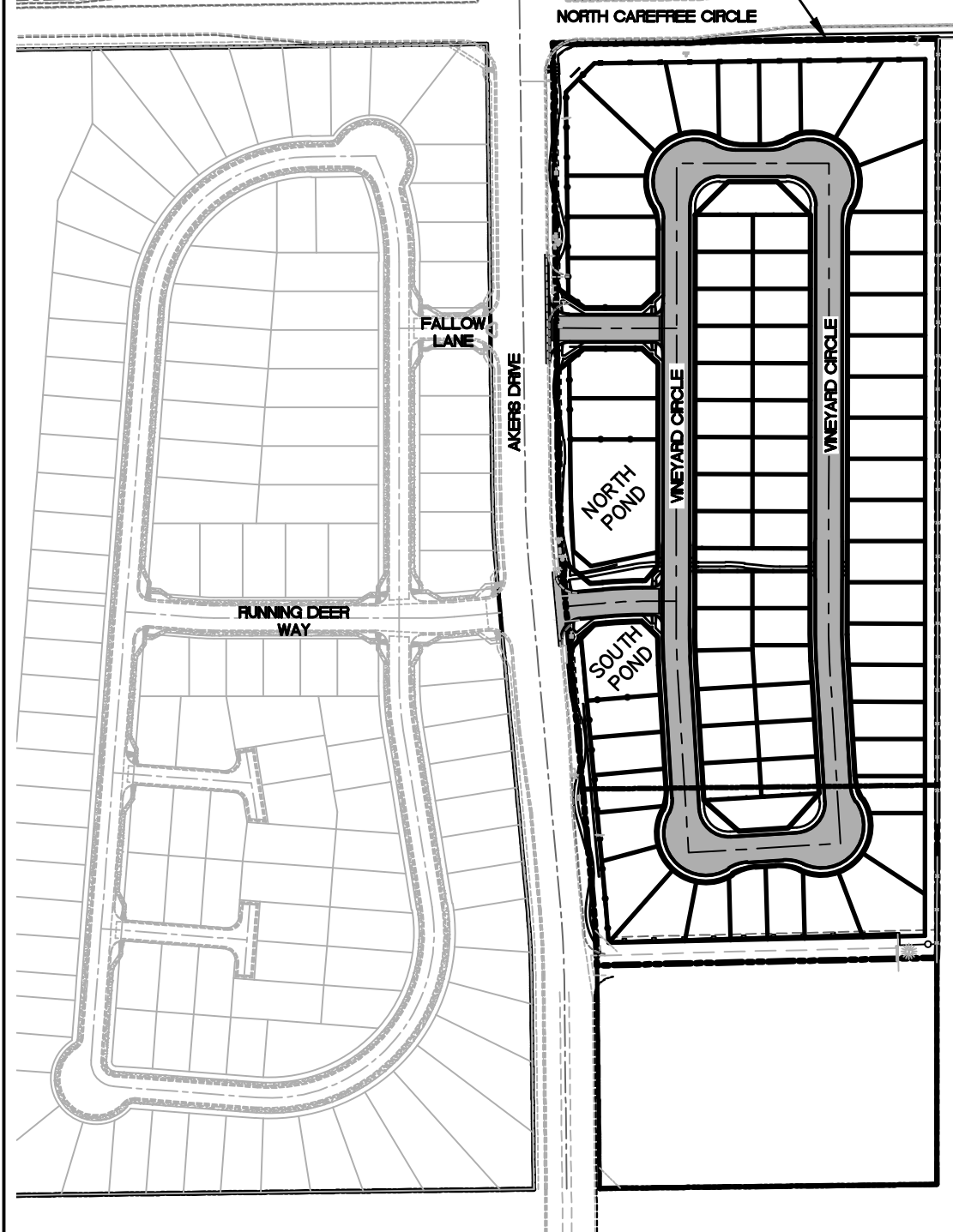

V:\52876\ACTIVE\187608744\MULE DEER\REPORTS\DRAINAGE\EXHIBITS\FDR\FIG01-VMAP.DWG
8/1/2019 2:44 PM

JANUARY, 2019
187608744

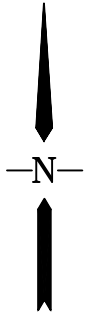

5725 MARK DABLING BLVD, SUITE 190
COLORADO SPRINGS, CO 80919
www.stantec.com

Client/Project
MULE DEER INVESTMENTS, LLC
GARDENS AT NORTH CAREFREE

Figure No. _____
1.0
Title
VICINITY MAP

The climate of the study area is characterized by mild summers and winters, light precipitation, high evaporation and moderately high wind velocities.

The climate of the site is typical of a sub-humid to semiarid climate with mild summers and winters. The average temperature is 31 degrees F in the winter and 68.4 degrees in the summer. Total annual precipitation is 15.21 inches.

3.7 Natural Hazards Analysis

Natural hazards analysis indicates that no unusual surface or subsurface hazards are located in the service area. However, because the soils are cohesionless, sloughing of steep banks during drilling and/or excavation could occur. By siting improvements in a manner that provides an opportunity to lay the banks of excavations back at a 1:1 slope during construction, the problems associated with sloughing soils can be minimized.

3.8 Organizational Context

The Gardens at North Carefree is situated within the Sand Creek Drainage Basin. There are only Cherokee and the City of Colorado Springs as service providers near to the development. Cherokee has been servicing the adjacent properties for nearly 20 years.

The most likely water service provider for The Gardens at North Carefree will continue to be Cherokee Metropolitan District.

The service provider Cherokee Metropolitan District will service the area and will be the entity responsible to finance construction and ensure the continuing operation and maintenance of improvements.

3.9 Water Facilities

The Cherokee Metropolitan District have been providing potable water service for a long period of time in accordance with the Colorado Department of Health and Environment.

Appendix A contains the current Cherokee Metropolitan District Water report.

3.10 Relationship to Neighboring Water and Wastewater Facilities

The location of other major water and wastewater facilities, relative to the Waterview Development, are shown on Figure 3.

Figure 2 identifies water wells and habitable buildings within a 1-mile radius of the center of The Gardens at North Carefree. No known wells are within the 1-mile radius.

3.11 Water Demand

The Gardens at North Carefree development will be serviced by Cherokee Metropolitan District. The average district wide water demands is indicated below:

Cherokee Metropolitan District: 0.31 ac-ft./year per Single Family Equivalent

These demands have been developed from actual usage records and recognized by the Sate Engineers Office. These water demands include irrigation; no separate meters are provided for irrigation.

V:\52876\ACTIVE\187608744-MULE DEER\REPORTS\WATER SUPPLY REPORT\ONE-MILE RADIUS MAP.DWG
8/3/2018 10:58 AM

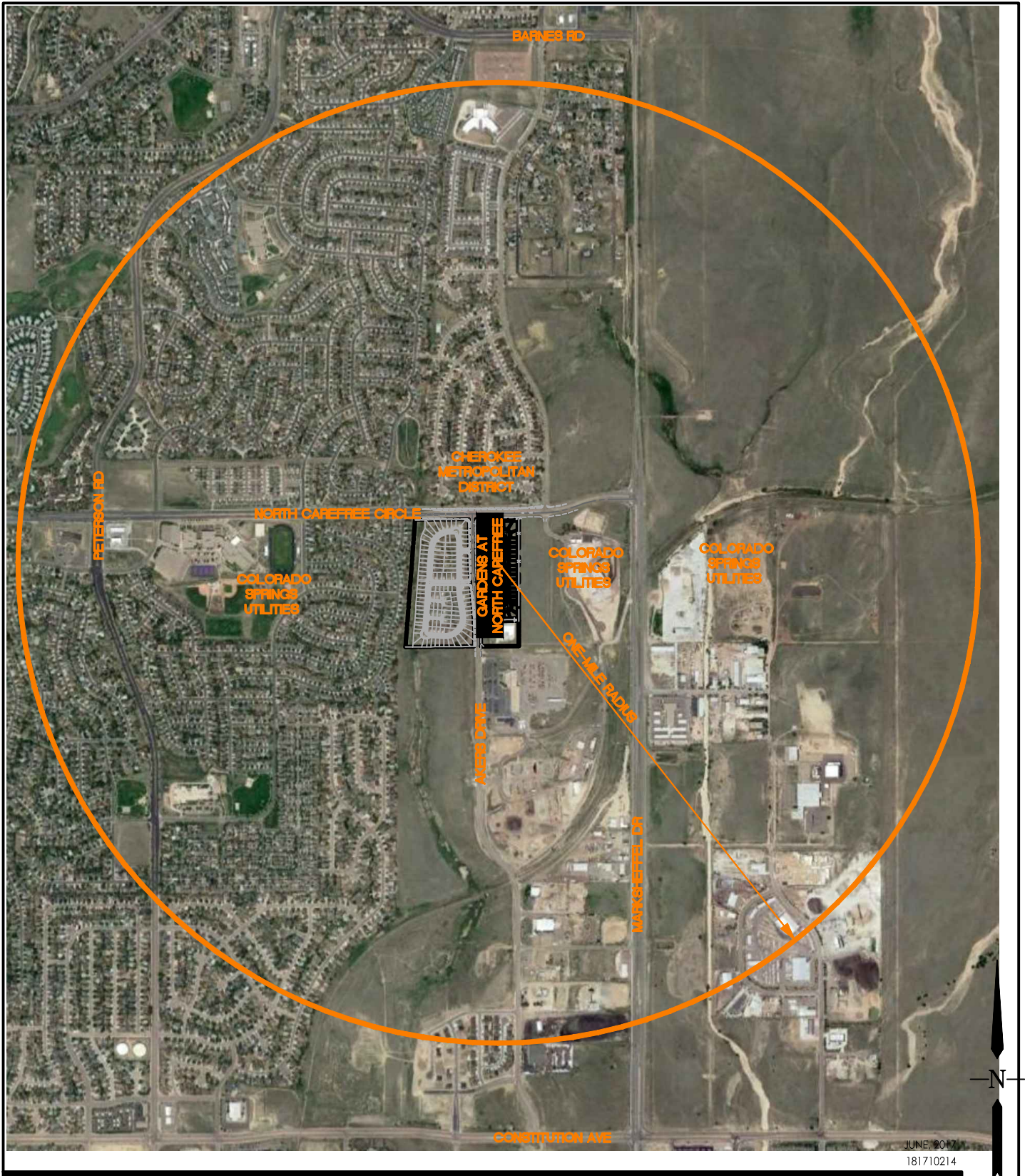

JUNE, 2017
181710214



5725 MARK DABLING BLVD, SUITE 190
COLORADO SPRINGS, CO 80919
www.stantec.com

Client/Project
MULE DEER INVESTMENTS, LLC
GARDENS AT NORTH CAREFREE

Figure No.
1.0

Title
ONE MILE RADIUS MAP

V:\52876\active\187608744-Mule Deer\CAD\Sheets\Construction Drawings\30 - Master Utility Plan.dwg
 2019/08/12 9:40 AM By: Durham, Charlene

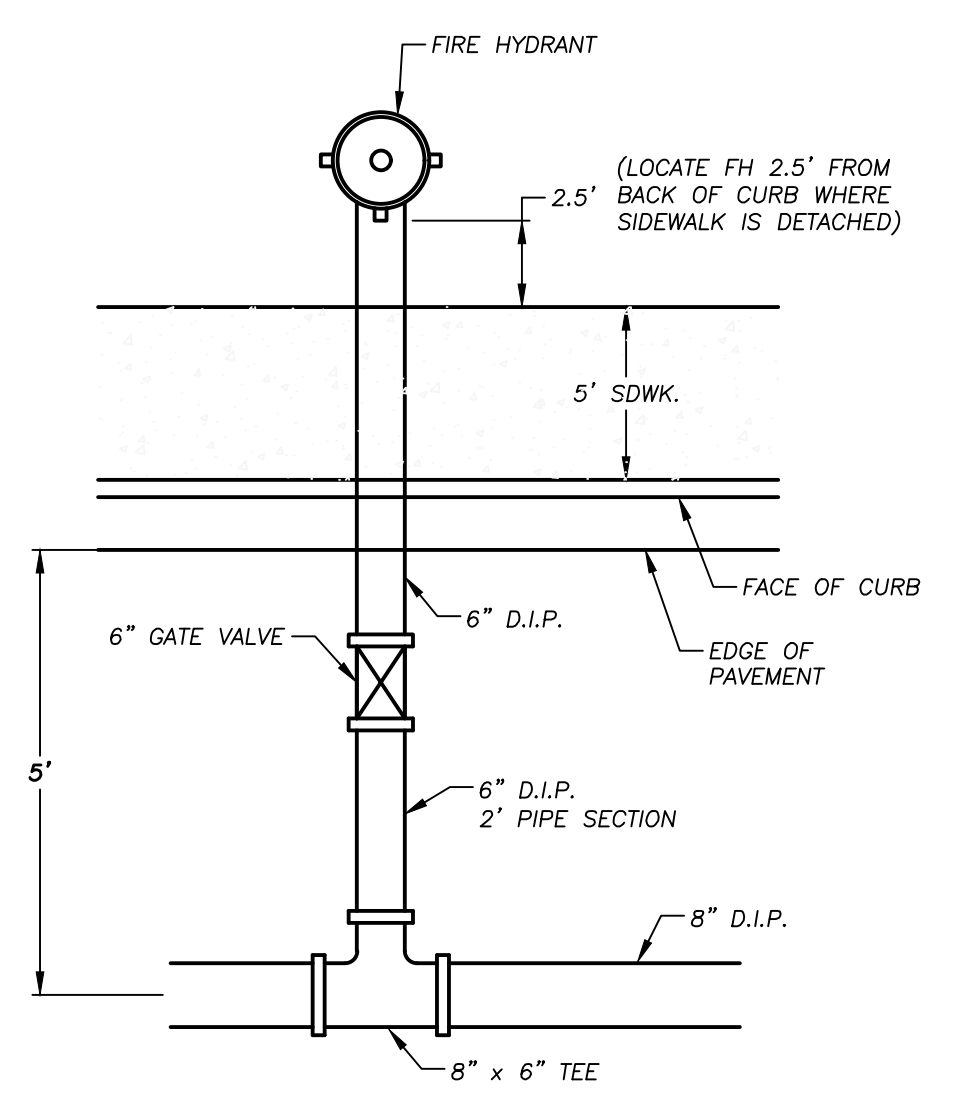
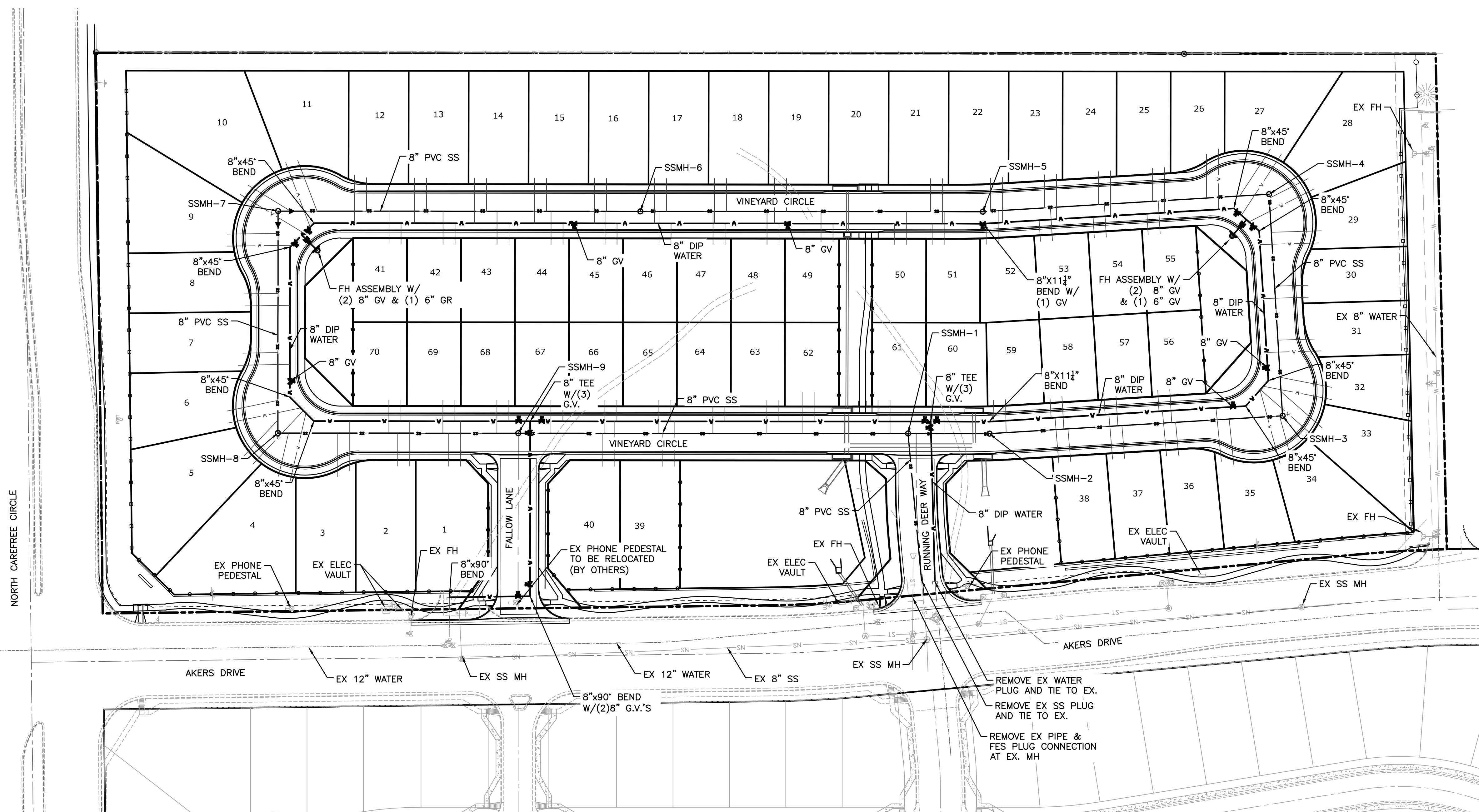

FIRE HYDRANT CONFIGURATION
 SCALE : N.T.S.

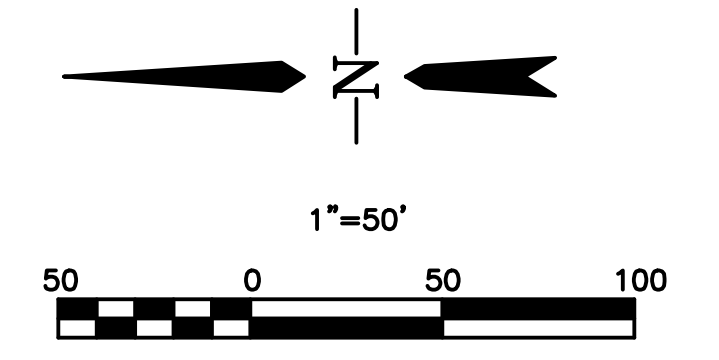

LEGEND

- EX WATER
- EX SAN SEWER
- EX GAS
- EX STORM SEWER
- EX WATER VALVE
- EX FIRE HYDRANT
- EX SANITARY SEWER MH
- PR WATER LINE
- PR SANITARY SEWER
- PR STORM SEWER
- PR SANITARY SEWER MANHOLE
- PR STORM SEWER MANHOLE
- PR WATER VALVE
- PR FIRE HYDRANT

- NOTES:**
- MECHANICAL MEANS SHOULD NOT BE USED TO ACCOMPLISH CURVED PIPE ALIGNMENTS WITH THE WASTEWATER PVC PIPE. IT IS THE INTENT THAT THIS SHOULD BE ACCOMPLISHED MANUALLY IN THE TRENCH BY THE INSTALLATION PERSONNEL. THE CURVE SHOULD BE ACCOMPLISHED BY BENDING THE PIPE RATHER THAN DEFLECTING THE JOINTS. OVER-BENDING OF JOINTS SHOULD BE AVOIDED. WATERLINE DUCTILE IRON PIPE DEFLECTIONS TO BE ACCOMPLISHED IN ACCORDANCE WITH SECURITY WATER DISTRICT STANDARDS.
 - THE MINIMUM RADIUS OF CURVATURE FOR 8-INCH PVC DIAMETER PIPE IS 200 FEET.
 - ALL WATER SERVICES TO BE 1" BLUE HDPE PIPE, ASTM D2737; AWWA C901, DR 9, 250 PSI PRESSURE RATING ACCOMPANIED BY A TRACER WIRE (SEE SHEET 2 CHEROKEE METRO UTILITY GENERAL NOTE # 13).

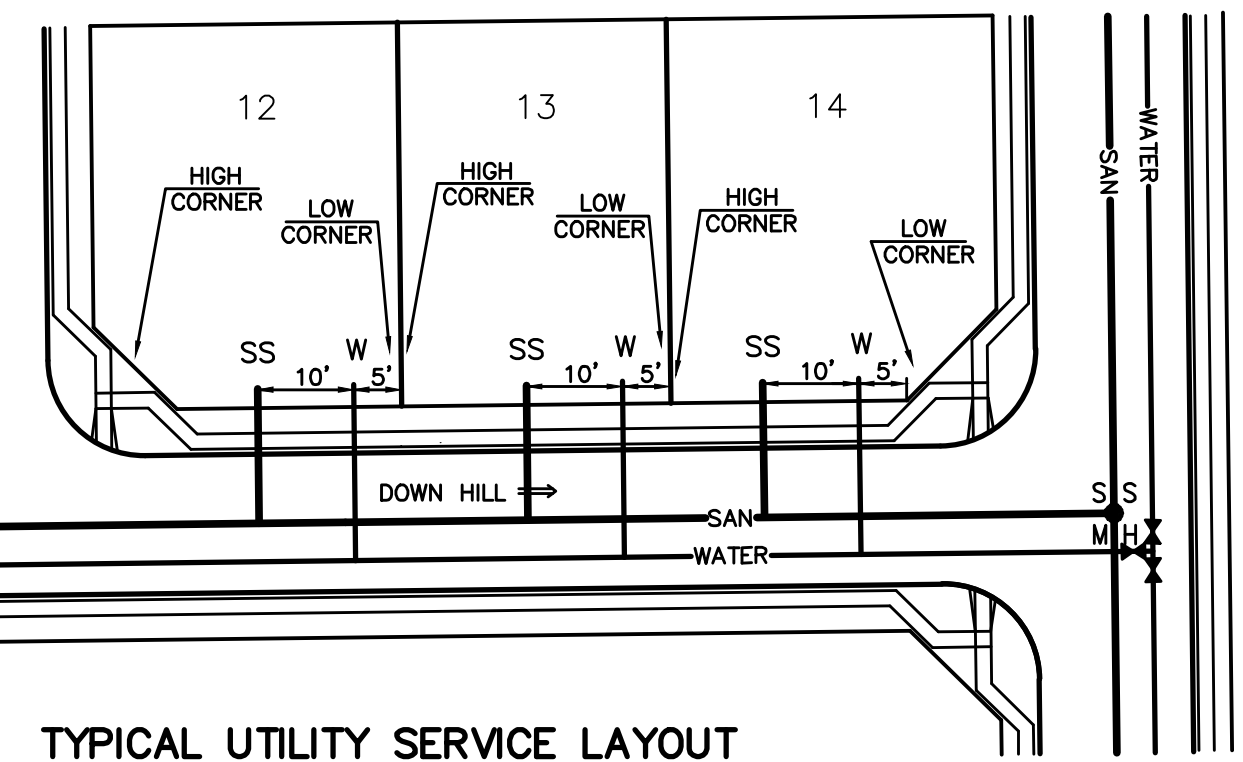

| Computer File Information | |
|--------------------------------|--------------------|
| Creation Date: 4-25-17 | Initials: CMD |
| Last Modification Date: | Initials: |
| Full Path & Drawing File Name: | |
| Acad Ver. 2014 | Scale: Units: Feet |

| Index of Revisions | |
|--------------------|--|
| | |
| | |
| | |
| | |

Stantec
 Stantec Consulting Inc.
 5725 MARK DABLING BLVD
 Suite 190
 Colorado Springs, CO 80919
 Tel. (719) 594-4535
 Fax.
 www.stantec.com

| THE GARDENS AT NORTH CAREFREE MASTER UTILITY PLAN | | |
|--|-------------------|--|
| Designer: CD | Structure Numbers | |
| Detailer: MB | | |
| Sheet Subst: | | |

| Project No./Code |
|------------------|
| 187608744 |
| SHEET 33 OF 34 |

Section 4 DEVELOPED CONDITIONS

4.1 Land Use

This report addresses The Gardens at North Carefree development anticipated to be submitted to El Paso County for review in March 2019. The proposed use is for 70 single family lots.

4.2 Population and Employment

By using the land use information noted above and applying standard unit densities of 2.9 persons per dwelling for single family residential uses, 2.5 persons per dwelling for multifamily residential uses and 600 square feet per employee for commercial/industrial uses, permanent resident and employment forecasts for The Gardens at North Carefree are 206 permanent residence.

4.3 Water Demand

By applying Cherokee Metropolitan District unit water demand factors to land use forecasts, water demands have been developed for ultimate build-out and are as follows:

$$70 \text{ SFE} \times 0.31 \text{ ac-ft./SFE} = 21.7 \text{ ac-ft.}$$

Unit water demands are based on actual District records as described in section 3.11 (**the Single Family Residential demands include irrigation because there is no separate meter for irrigation water**).

Water demand is first calculated in acre-feet per year (AFY) to determine water supply needs. This value is then factored to determine the average daily demand (ADD) in gallons per minute (gpm), which is used to project maximum day and peak hour demands as well as to estimate revenues and operating costs. Maximum day demand (MDD) and peak hour demand (PHD) have been determined by applying accepted peaking factors of 2.5 and 4.0 to the ADD, respectively. The MDD is used to determine storage needs and the PHD is used for modeling system delivery pressures and to size distribution piping.

Calculated demand is as follows:

| | | |
|--------|---|----------|
| Ac-ft. | = | 22.01 |
| ADD | = | 13.6 gpm |
| MDD | = | 34.1 gpm |
| PHD | = | 54.6 gpm |

Fire flow demand is another demand typically included in the design of water systems. A fire flow demand of 1500 gpm in residential areas and 3500 gpm in commercial areas will be delivered at a minimum pressure of 20 psi by the respective water systems.

4.4 Water Supply

The Cherokee Metropolitan District have numerous ground water and surface water rights; these water supply sources are summarized in Appendix A.

Based on the water demand and the available water sources the district is capable of servicing the proposed development.

4.5 Water Quality

The Cherokee Metropolitan District has been providing potable water in accordance with El Paso County health Department and Colorado Department of Health and Environment standards and reporting requirements for several decades. The district provides treatment and disinfection of their raw water sources prior to distribution. Water Quality is summarized in Appendix A.

Section 5
WATER SYSTEM IMPROVEMENTS

5.1 General

The water systems operated the Cherokee Metropolitan District are classified as "community water systems" and meets the applicable requirements of the Colorado Department of Health and Environment (CDHE).

Filtration and disinfection facilities provide treatment of the raw water sources to ensure good water quality. Elevation differences that exist throughout the district boundaries require different pressure zones to ensure that water is delivered at no less than 40 psi during peak hour flow and at no more than 120 psi during periods of low use. In addition, storage facilities and distribution piping will be provided to ensure that residual pressure requirements are achieved both during peak hour demands and during maximum day demands with a superimposed fire flow of 3500 gpm. The pressure zones are served by both storage facilities as well as transfer pumping equipment.

5.2 Groundwater Wells

The district has multiple sources of water including groundwater wells as outlined in Appendix A

5.3 Water Treatment

Treating and filtering of the water sources meets Drinking Water Standards.

In addition, CDHE standards require that the water supply be disinfected and that the supply receives minimum chlorine contact time of 30 minutes before first use.

5.4 Storage

Storage reservoirs are ground mounted and elevated steel tanks designed in accordance with CDHE and AWWA Standards.

Storage is sized to provide a minimum of 30% of maximum day demand and includes a reserve to supply a fire flow of 3500 gpm for three hours.

5.5 Distribution

The water distribution system provides water at a maximum static pressure of 120 psi during periods of low use, at a minimum residual pressure of 40 psi during peak hour demand and at a minimum residual pressure of 20 psi during maximum day demand with a superimposed fire flow of 3500 gpm. The distribution system uses a loop type system of piping to maximize the efficiency of the system and will be provided with minimum 6-inch diameter pipe and fire hydrants throughout. All pipe and appurtenances will be designed to meet or exceed AWWA standards.

5.6 Other Costs and Gains

Estimated Costs

| Item | Units | Quantity | Unit Price | Extension |
|----------------------|-------|----------|------------|------------------|
| Water Main Extension | LF | 2400 | \$65 | \$156,000 |
| Total Estimated Cost | | | | <i>\$156,000</i> |

The costs included above only include capital costs for water system improvements required to serve The

Gardens at North Carefree and are estimated from best available data. These costs do not include other costs or gains that may be incurred in the acquisition of land, financing, investing, local distribution, the salvage value of equipment or other necessary infrastructure, among others, unless specifically noted.

5.7 Rates and Charges

The Cherokee Metropolitan District will impose one-time charges to recoup the cost of constructing water system improvements as well as regular periodic billings to recoup continuing costs for operations, maintenance and equipment replacement. This system of rates and charts is published the district annually.

Appendix A

Cherokee Metropolitan District

CHEROKEE MD 2018 Drinking Water Quality Report

For Calendar Year 2017

Public Water System ID: CO0121125

Esta es información importante. Si no la pueden leer, necesitan que alguien se la traduzca.

We are pleased to present to you this year's water quality report. Our constant goal is to provide you with a safe and dependable supply of drinking water. Please contact JONATHON SMITH at 719-597-5080 with any questions or for public participation opportunities that may affect water quality.

General Information

All drinking water, including bottled water, may reasonably be expected to contain at least small amounts of some contaminants. The presence of contaminants does not necessarily indicate that the water poses a health risk. More information about contaminants and potential health effects can be obtained by calling the Environmental Protection Agency's Safe Drinking Water Hotline (1-800-426-4791) or by visiting <http://water.epa.gov/drink/contaminants>.

Some people may be more vulnerable to contaminants in drinking water than the general population. Immunocompromised persons such as persons with cancer undergoing chemotherapy, persons who have undergone organ transplants, people with HIV-AIDS or other immune system disorders, some elderly, and infants can be particularly at risk of infections. These people should seek advice about drinking water from their health care providers. For more information about contaminants and potential health effects, or to receive a copy of the U.S. Environmental Protection Agency (EPA) and the U.S. Centers for Disease Control (CDC) guidelines on appropriate means to lessen the risk of infection by Cryptosporidium and microbiological contaminants call the EPA Safe Drinking Water Hotline at (1-800-426-4791).

The sources of drinking water (both tap water and bottled water) include rivers, lakes, streams, ponds, reservoirs, springs, and wells. As water travels over the surface of the land or through the ground, it dissolves naturally occurring minerals and, in some cases, radioactive material, and can pick up substances resulting from the presence of animals or from human activity. Contaminants that may be present in source water include:

- **Microbial contaminants:** viruses and bacteria that may come from sewage treatment plants, septic systems, agricultural livestock operations, and wildlife.
- **Inorganic contaminants:** salts and metals, which can be naturally-occurring or result from urban storm water runoff, industrial or domestic wastewater discharges, oil and gas production, mining, or farming.
- **Pesticides and herbicides:** may come from a variety of sources, such as agriculture, urban storm water runoff, and residential uses.
- **Radioactive contaminants:** can be naturally occurring or be the result of oil and gas production and mining activities.
- **Organic chemical contaminants:** including synthetic and volatile organic chemicals, which are byproducts of industrial processes and petroleum production, and also may come from gas stations, urban storm water runoff, and septic systems.

In order to ensure that tap water is safe to drink, the Colorado Department of Public Health and Environment prescribes regulations limiting the amount of certain contaminants in water provided by public water systems. The Food and Drug Administration regulations establish limits for contaminants in bottled water that must provide the same protection for public health.

Lead in Drinking Water

If present, elevated levels of lead can cause serious health problems (especially for pregnant women and young children). It is possible that lead levels at your home may be higher than other homes in the community as a result of materials used in your home’s plumbing. If you are concerned about lead in your water, you may wish to have your water tested. When your water has been sitting for several hours, you can minimize the potential for lead exposure by flushing your tap for 30 seconds to 2 minutes before using water for drinking or cooking. Additional information on lead in drinking water, testing methods, and steps you can take to minimize exposure is available from the Safe Drinking Water Hotline (1-800-426-4791) or at <http://www.epa.gov/safewater/lead>.

Source Water Assessment and Protection (SWAP)

The Colorado Department of Public Health and Environment has provided us with a Source Water Assessment Report for our water supply. For general information or to obtain a copy of the report please visit www.colorado.gov/cdphe/ccr. The report is located under “Guidance: Source Water Assessment Reports”. Search the table using 121125, CHEROKEE MD, or by contacting JONATHON SMITH at 719-597-5080. The Source Water Assessment Report provides a screening-level evaluation of potential contamination that ***could*** occur. It ***does not*** mean that the contamination ***has or will*** occur. We can use this information to evaluate the need to improve our current water treatment capabilities and prepare for future contamination threats. This can help us ensure that quality finished water is delivered to your homes. In addition, the source water assessment results provide a starting point for developing a source water protection plan. Potential sources of contamination in our source water area are listed on the next page.

Please contact us to learn more about what you can do to help protect your drinking water sources, any questions about the Drinking Water Quality Report, to learn more about our system, or to attend scheduled public meetings. We want you, our valued customers, to be informed about the services we provide and the quality water we deliver to you every day.

Our Water Sources

| <u>Source</u> | <u>Source Type</u> | <u>Water Type</u> | <u>Potential Source(s) of Contamination</u> |
|---------------------|--------------------|-------------------|--|
| WELLS 1 THROUGH 13 | Well | Groundwater | Row crops, fallow, small grains, pasture/hay, septic systems, road miles |
| WELLS 15 THROUGH 20 | Well | Groundwater | |
| WELL 21 AR-1 | Well | Groundwater | |
| WELL 22 DN-4 | Well | Groundwater | |

Terms and Abbreviations

- **Maximum Contaminant Level (MCL)** – The highest level of a contaminant allowed in drinking water.
- **Treatment Technique (TT)** – A required process intended to reduce the level of a contaminant in drinking water.
- **Health-Based** – A violation of either a MCL or TT.
- **Non-Health-Based** – A violation that is not a MCL or TT.
- **Action Level (AL)** – The concentration of a contaminant which, if exceeded, triggers treatment and other regulatory requirements.
- **Maximum Residual Disinfectant Level (MRDL)** – The highest level of a disinfectant allowed in drinking water. There is convincing evidence that addition of a disinfectant is necessary for control of microbial contaminants.
- **Maximum Contaminant Level Goal (MCLG)** – The level of a contaminant in drinking water below which there is no known or expected risk to health. MCLGs allow for a margin of safety.
- **Maximum Residual Disinfectant Level Goal (MRDLG)** – The level of a drinking water disinfectant, below which there is no known or expected risk to health. MRDLGs do not reflect the benefits of the use of disinfectants to control microbial contaminants.
- **Violation (No Abbreviation)** – Failure to meet a Colorado Primary Drinking Water Regulation.
- **Formal Enforcement Action (No Abbreviation)** – Escalated action taken by the State (due to the risk to public health, or number or severity of violations) to bring a non-compliant water system back into compliance.
- **Variance and Exemptions (V/E)** – Department permission not to meet a MCL or treatment technique under certain conditions.
- **Gross Alpha (No Abbreviation)** – Gross alpha particle activity compliance value. It includes radium-226, but excludes radon 222, and uranium.
- **Picocuries per liter (pCi/L)** – Measure of the radioactivity in water.
- **Nephelometric Turbidity Unit (NTU)** – Measure of the clarity or cloudiness of water. Turbidity in excess of 5 NTU is just noticeable to the typical person.
- **Compliance Value (No Abbreviation)** – Single or calculated value used to determine if regulatory contaminant level (e.g. MCL) is met. Examples of calculated values are the 90th Percentile, Running Annual Average (RAA) and Locational Running Annual Average (LRAA).
- **Average (x-bar)** – Typical value.
- **Range (R)** – Lowest value to the highest value.
- **Sample Size (n)** – Number or count of values (i.e. number of water samples collected).
- **Parts per million = Milligrams per liter (ppm = mg/L)** – One part per million corresponds to one minute in two years or a single penny in \$10,000.
- **Parts per billion = Micrograms per liter (ppb = ug/L)** – One part per billion corresponds to one minute in 2,000 years, or a single penny in \$10,000,000.
- **Not Applicable (N/A)** – Does not apply or not available.
- **Level 1 Assessment** – A study of the water system to identify potential problems and determine (if possible) why total coliform bacteria have been found in our water system.
- **Level 2 Assessment** – A very detailed study of the water system to identify potential problems and determine (if possible) why an E. coli MCL violation has occurred and/or why total coliform bacteria have been found in our water system on multiple occasions.

Detected Contaminants

CHEROKEE MD routinely monitors for contaminants in your drinking water according to Federal and State laws. The following table(s) show all detections found in the period of January 1 to December 31, 2017 unless otherwise noted. The State of Colorado requires us to monitor for certain contaminants less than once per year because the concentrations of these contaminants are not expected to vary significantly from year to year, or the system is not considered vulnerable to this type of contamination. Therefore, some of our data, though representative, may be more than one year old. Violations and Formal Enforcement Actions, if any, are reported in the next section of this report.

Note: Only detected contaminants sampled within the last 5 years appear in this report. If no tables appear in this section then no contaminants were detected in the last round of monitoring.

| Disinfectants Sampled in the Distribution System | | | | | | |
|---|--------------------------|---|-------------------------------|-------------|--------------|---------|
| TT Requirement: At least 95% of samples per period (month or quarter) must be at least 0.2 ppm OR If sample size is less than 40 no more than 1 sample is below 0.2 ppm Typical Sources: Water additive used to control microbes | | | | | | |
| Disinfectant Name | Time Period | Results | Number of Samples Below Level | Sample Size | TT Violation | MRDL |
| Chlorine | 01/01/2017 to 12/31/2017 | Lowest period percentage of samples meeting TT requirement: 96% | 0 | 255 | No | 4.0 ppm |

| Lead and Copper Sampled in the Distribution System | | | | | | | | |
|---|--------------------------|-----------------------------|-------------|-----------------|--------------------------------|-----------------------|---|--|
| Contaminant Name | Time Period | 90 th Percentile | Sample Size | Unit of Measure | 90 th Percentile AL | Sample Sites Above AL | 90 th Percentile AL Exceedance | Typical Sources |
| Copper | 06/13/2017 to 06/15/2017 | 0.42 | 30 | ppm | 1.3 | 0 | No | Corrosion of household plumbing systems; Erosion of natural deposits |
| Lead | 06/13/2017 to 06/15/2017 | 4 | 30 | ppb | 15 | 2 | No | Corrosion of household plumbing systems; Erosion of natural deposits |

Disinfection Byproducts Sampled in the Distribution System

| Name | Year | Average | Range Low – High | Sample Size | Unit of Measure | MCL | MCLG | Highest Compliance Value | MCL Violation | Typical Sources |
|----------------------------------|------|---------|---------------------|----------------|--------------------|-----|------|--------------------------------|------------------|---|
| Total Haloacetic Acids (HAA5) | 2017 | 4.46 | 0 to 8.5 | 16 | ppb | 60 | N/A | 8.5 | No | Byproduct of drinking water disinfection |
| Total Trihalomethanes (TTHM) | 2017 | 19.03 | 5.6 to 34.5 | 16 | ppb | 80 | N/A | 34.5 | No | Byproduct of drinking water disinfection |

Radionuclides Sampled at the Entry Point to the Distribution System

| Typical Sources | Year | Average | Range Low – High | Sample Size | Unit of Measure | MCL | MCLG | MCL Violation | Typical Sources |
|------------------------------|------|---------|---------------------|----------------|--------------------|-----|------|------------------|---|
| Gross Alpha | 2017 | 1.1 | 1.1 to 1.1 | 1 | pCi/L | 15 | 0 | No | Erosion of natural deposits |
| Combined Radium | 2017 | 3.4 | 3.4 to 3.4 | 1 | pCi/L | 5 | 0 | No | Erosion of natural deposits |
| Gross Beta Particle Activity | 2016 | 0.1 | 0.1 to 0.1 | 1 | pCi/L* | 50 | 0 | No | Decay of natural and man-made deposits |

*The MCL for Gross Beta Particle Activity is 4 mrem/year. Since there is no simple conversion between mrem/year and pCi/L EPA considers 50 pCi/L to be the level of concern for Gross Beta Particle Activity.

Inorganic Contaminants Sampled at the Entry Point to the Distribution System

| Contaminant Name | Year | Average | Range Low – High | Sample Size | Unit of Measure | MCL | MCLG | MCL Violation | Typical Sources |
|------------------|------|---------|---------------------|----------------|--------------------|-----|------|------------------|---|
| Arsenic | 2017 | 0.33 | 0 to 2 | 6 | ppb | 10 | 0 | No | Erosion of natural deposits; runoff from orchards; runoff from glass and electronics production wastes |
| Barium | 2017 | 0.06 | 0.04 to 0.07 | 6 | ppm | 2 | 2 | No | Discharge of drilling wastes; discharge from metal refineries; erosion of natural deposits |
| Fluoride | 2017 | 0.74 | 0.31 to 1.6 | 3 | ppm | 4 | 4 | No | Erosion of natural deposits; water additive which promotes strong teeth; discharge from fertilizer and aluminum factories |
| Nitrate | 2017 | 6.94 | 0 to 9.3 | 9 | ppm | 10 | 10 | No | Runoff from fertilizer use; leaching from septic tanks, sewage; erosion of natural deposits |
| Selenium | 2017 | 4.33 | 0 to 8 | 6 | ppb | 50 | 50 | No | Discharge from petroleum and metal refineries; erosion of natural deposits; discharge from mines |

Nitrate: *Nitrate in drinking water at levels above 10 ppm* is a health risk for infants of less than six months of age. High nitrate levels in drinking water can cause blue baby syndrome. Nitrate levels may rise quickly for short periods of time because of rainfall or agricultural activity. If you are caring for an infant you should ask advice from your health care provider.

Secondary Contaminants**

**Secondary standards are non-enforceable guidelines for contaminants that may cause cosmetic effects (such as skin, or tooth discoloration) or aesthetic effects (such as taste, odor, or color) in drinking water.

| Contaminant Name | Year | Average | Range Low – High | Sample Size | Unit of Measure | Secondary Standard |
|------------------------|------|---------|---------------------|----------------|--------------------|-----------------------|
| Sodium | 2017 | 49.82 | 21.1 to 73.2 | 6 | ppm | N/A |
| Total Dissolved Solids | 2017 | 337.7 | 248 - 472 | 16 | ppm | 500 |

Violations, Significant Deficiencies, Backflow/Cross-Connection, and Formal Enforcement Actions

| Violations | | | | | |
|--|---|-------------------------|-----------------------------------|------------------|-----------------|
| Name | Category | Time Period | Health Effects | Compliance Value | TT Level or MCL |
| CROSS CONNECTION RULE | FAILURE TO MEET CROSS CONNECTION/BACKFLOW REQUIREMENTS - HEALTH-BASED | 01/01/2017 - 06/12/2017 | May pose a risk to public health. | N/A | N/A |
| Additional Violation Information | | | | | |
| <p>*Please share this information with all the other people who drink this water, especially those who may not have received this notice directly (for example, people in apartments, nursing homes, schools, and businesses). You can do this by posting this notice in a public place or distributing copies by hand or mail.*</p> <p>Explanation of the violation(s), the steps taken to resolve them, and the anticipated resolved date:</p> | | | | | |

| Backflow and Cross-Connection |
|---|
| <p>Cherokee Metropolitan District had an inadequate backflow prevention and cross-connection control program in 2016 and failed to meet the specified percentage of backflow device testing required by the Colorado Department of Public Health and Environment. The District is currently in compliance with the Cross Connection Rule. Uncontrolled cross connections can lead to inadvertent contamination of the drinking water.</p> |

Appendix B

District Letter of Commitment



CHEROKEE METROPOLITAN DISTRICT

6250 Palmer Park Blvd., Colorado Springs, CO 80915-2842

Telephone: (719) 597-5080 Fax: (719) 597-5145

August 3, 2018

Mr. Heath Herber
c/o Mule Deer Investments
31 N. Tejon Street
Suite 532
Colorado Springs, CO 80903

Re: Residential Development – The Gardens at North Carefree
Commitment Letter #2018-07 (revision of Commitment Letter #2018-03)

Dear Mr. Herber

As requested, this letter is being provided as a formal Letter of Commitment by the Cherokee Metropolitan District (District) to provide municipal water and sewer service for the above-mentioned development. Since the development has been revised from 125 townhomes to 71 single family homes, this commitment letter is a revision of Commitment Letter #2018-03 that was issued on April 20, 2018 by Kurt Schlegel. The parcel of land is located within the District's service boundary and, therefore, the District stands ready and willing to provide water and sewer service for the specific property and uses detailed herein.

As of October 2015, the State Engineer's Office has given the District a favorable opinion on the District's quantification of water supplies available for new subdivisions and commercial developments. The State Engineer confirmed, through a Technical Memorandum prepared by Forsgren Associates, that the District had a surplus of 453 acre feet per year of water available for new developments as of May 18, 2016. Since that time, the District has issued 83.829 acre feet per year of water commitments leaving a balance of 369.171 acre feet per year of water for future developments. The Gardens at North Carefree development requires 22.010 acre feet per year of water leaving the District with a water balance of 347.161 acre feet per year for future developments.

Regarding the wastewater capacity, the District's Water Reclamation Facility (WRF) has the required capacity to meet the sewer demand for this development. The WRF is rated for 4.8 million gallons per day (MGD), of which 2.6 MGD is owned by the District and reserved for District's customers. The District's current contribution to the WRF is 1.560 MGD with a committed capacity of 1.593 MGD, therefore, there is an excess of 1.040 MGD of treatment capacity available and 1.007 MGD of

available capacity for future commitments. Based on the information received in the "Engineering Study for The Gardens at North Carefree Wastewater System Improvements" report dated July 2018 by Stantec, this development is estimated to discharge 15,718 gallons of wastewater per day which equates to 1.56% of the available capacity of the WRF leaving 0.991 MGD of capacity available for future developments.

This water commitment is hereby made exclusively for this specific development project at this site, within the District, and must achieve appropriate zoning and a final plat land use entitlement from El Paso County Development Services within 12 months from the date of this letter; otherwise, the District may use this allocation for other developments requesting a water commitment for growth that stands ready to develop.

The District and I trust that you find this letter adequate for your needs and land use applications. If I may be of further assistance, please contact me at your convenience.

Best Regards,



Jonathon Smith
Water & Wastewater Collections Manager

Encl: Water Balance and Water Commitments (Cherokee Metropolitan District)
Commitment Letter #2018-03 for Mule Deer Villas (dated April 20, 2018)
Water Supply Information Summary for The Gardens at North Carefree
Water System Improvements for The Gardens at North Carefree; pages #1 and #9
Wastewater System Improvements for The Gardens at North Carefree; pages #1 and #4
Vicinity Map for The Gardens at North Carefree
Site Utilities Plan for The Gardens at North Carefree

Ec: Brian Beaudette, Interim General Manager, Cherokee Metropolitan District
Charles Cothern, Senior Project Manager, Stantec
Erin Ganaway, Project Engineer, N.E.S. Inc.

Water Balance and Water Commitments (Cherokee Metropolitan District)

| <u>Development</u> | <u>Business Name</u> | <u>Address</u> | <u>Commitment Letter</u> | <u>Acres</u> |
|--|---|--|--------------------------|--------------|
| | | | <u>Letter #</u> | <u>Date</u> |
| SEC Marksheffel Road and Constitution Avenue Phase #2 | SEC Marksheffel Road and Constitution Avenue Phase #2 | SEC Marksheffel Road and Constitution Avenue | 2015-01 | Expired |
| Windermere Filing #1 | Windermere Subdivision Filing #1 | NEC Anteloper Ridge Drive and N. Carefree Circle | 2015-02 | Expired |
| Constitution Apartment Complex | Constitution Apartments | 6855 Constitution Avenue | 2016-01 | Expired |
| Meadowbrook Crossing Subdivision | Meadowbrook Crossing | Meadowbrook Parkway and Highway 24 | 2017-01 | 5/4/2017 |
| Kum & Go Store #692 | Kum & Go | 6809 Space Village Avenue | 2017-02 | 9/8/2017 |
| Freedom Springs Apartment Complex | Freedom Springs | 734 Western Drive | 2018-01 | 2/22/2018 |
| Covert Ops Paintball | Covert Ops Paintball | 6425 E. Platte Avenue | 2018-02 | 3/22/2018 |
| Mule Deer Villas Subdivision | Mule Deer Villas | SEC Akers Drive and N. Carefree Circle | 2018-03 | 4/20/2018 |
| Mule Deer Villas Subdivision | Mule Deer Villas | SEC Akers Drive and N. Carefree Circle | 2018-03 | Revised |
| Appaloosa Highway 24 Subdivision Filing #2 | Appaloosa Highway 24 Subdivision Filing #2 | SEC Amelia Street & Terminal Avenue | 2018-04 | 6/13/2018 |
| SEC Marksheffel Road and Constitution Avenue Phase #2 | SEC Marksheffel Road and Constitution Avenue Phase #2 | SEC Marksheffel Road and Constitution Avenue | 2018-05 | 7/6/2018 |
| Windermere Subdivision | Windermere | NEC Anteloper Ridge Drive and N. Carefree Circle | 2018-06 | 7/6/2018 |
| Gardens at North Carefree Subdivision (Mule Deer Villas) | Gardens at North Carefree | SEC Akers Drive and N. Carefree Circle | 2018-07 | 8/3/2018 |
| | | | | |
| | | | | |
| | | | | |
| | | | | |
| | | | | |

Water Balance Beginning as of May 18, 2016 (AFY) 453.000

Water Committed since May 18, 2016 (AFY) 105.839

Water Balance Remaining for Future Commitments (AFY) 347.161

Appendix C

Water Supply Summary

WATER SUPPLY INFORMATION SUMMARY

Section 30-28-122.(d). C.R.S. requires that the applicant submit to the County. "Adequate evidence that a water supply that is sufficient in terms of quantity, quality and dependability will be available to ensure an adequate supply of water.

| | | | | | | | | | | | | | | | | | | | | | | | | | | | |
|--|--|--|--|--|--|--|--|----------------------------------|----------------|---|--|----------------------------------|----------------|---|--|----------------------------------|----------------|---|--|----------------------------------|----------------|---|--|----------------------------------|----------------|---|--|
| 1. NAME OF DEVELOPMENT AS PROPOSED | | | | | | | | | | | | | | | | | | | | | | | | | | | |
| The Gardens at North Carefree | | | | | | | | | | | | | | | | | | | | | | | | | | | |
| 2. LAND USE ACTION | | | | | | | | | | | | | | | | | | | | | | | | | | | |
| Final Plat | | | | | | | | | | | | | | | | | | | | | | | | | | | |
| 3. NAME OF EXISTING PARCEL AS RECORDED | | | | | | | | | | | | | | | | | | | | | | | | | | | |
| Hilltop Sketch Plan | | | | | | | | | | | | | | | | | | | | | | | | | | | |
| SUBDIVISION | | FILING | | | | | | | | | | | | | | | | | | | | | | | | | |
| Hilltop Sketch Plan | | | | | | | | | | | | | | | | | | | | | | | | | | | |
| 4. TOTAL ACREAGE | | 5. NUMBER OF LOTS PROPOSED | | | | | | | | | | | | | | | | | | | | | | | | | |
| 11.56 | | 70 | | | | | | | | | | | | | | | | | | | | | | | | | |
| PLAT MAP ENCLOSED <input type="checkbox"/> YES | | | | | | | | | | | | | | | | | | | | | | | | | | | |
| 6. PARCEL HISTORY – The site was Sketch Planned in 1999. Property to the north, south and west have been platted. | | | | | | | | | | | | | | | | | | | | | | | | | | | |
| A. Was parcel recorded with county prior to June 1, 1972? <input type="checkbox"/> YES <input checked="" type="checkbox"/> NO B. Has the parcel ever been part of a division of land action since June 1, 1972? <input checked="" type="checkbox"/> YES <input type="checkbox"/> NO If yes, describe the previous action <u>Mule Deer Business Park Filing No. 2</u> | | | | | | | | | | | | | | | | | | | | | | | | | | | |
| 7. LOCATION OF PARCEL – Include a map delineating the project area and tie to a section corner. | | | | | | | | | | | | | | | | | | | | | | | | | | | |
| <table style="width: 100%; border: none;"> <tr> <td style="width: 25%;">E 1/2 of --- 1/4 SECTION <u>29</u></td> <td style="width: 25%;">TOWNSHIP <u>13</u></td> <td style="width: 25%;"><input type="checkbox"/> N <input checked="" type="checkbox"/> S RANGE <u>65</u></td> <td style="width: 25%;"><input type="checkbox"/> E <input checked="" type="checkbox"/> W</td> </tr> <tr> <td>--- 1/4 of --- 1/4 SECTION _____</td> <td>TOWNSHIP _____</td> <td><input type="checkbox"/> N <input type="checkbox"/> S RANGE _____</td> <td><input type="checkbox"/> E <input checked="" type="checkbox"/> W</td> </tr> <tr> <td>--- 1/4 of --- 1/4 SECTION _____</td> <td>TOWNSHIP _____</td> <td><input type="checkbox"/> N <input type="checkbox"/> S RANGE _____</td> <td><input type="checkbox"/> E <input checked="" type="checkbox"/> W</td> </tr> <tr> <td>--- 1/4 of --- 1/4 SECTION _____</td> <td>TOWNSHIP _____</td> <td><input type="checkbox"/> N <input type="checkbox"/> S RANGE _____</td> <td><input type="checkbox"/> E <input checked="" type="checkbox"/> W</td> </tr> <tr> <td>--- 1/4 of --- 1/4 SECTION _____</td> <td>TOWNSHIP _____</td> <td><input type="checkbox"/> N <input type="checkbox"/> S RANGE _____</td> <td><input type="checkbox"/> E <input checked="" type="checkbox"/> W</td> </tr> <tr> <td>--- 1/4 of --- 1/4 SECTION _____</td> <td>TOWNSHIP _____</td> <td><input type="checkbox"/> N <input type="checkbox"/> S RANGE _____</td> <td><input type="checkbox"/> E <input checked="" type="checkbox"/> W</td> </tr> </table> PRINCIPAL MERIDIAN: <input checked="" type="checkbox"/> 6 TH <input type="checkbox"/> N.M. <input type="checkbox"/> UTE <input type="checkbox"/> COSTILLA | | | | E 1/2 of --- 1/4 SECTION <u>29</u> | TOWNSHIP <u>13</u> | <input type="checkbox"/> N <input checked="" type="checkbox"/> S RANGE <u>65</u> | <input type="checkbox"/> E <input checked="" type="checkbox"/> W | --- 1/4 of --- 1/4 SECTION _____ | TOWNSHIP _____ | <input type="checkbox"/> N <input type="checkbox"/> S RANGE _____ | <input type="checkbox"/> E <input checked="" type="checkbox"/> W | --- 1/4 of --- 1/4 SECTION _____ | TOWNSHIP _____ | <input type="checkbox"/> N <input type="checkbox"/> S RANGE _____ | <input type="checkbox"/> E <input checked="" type="checkbox"/> W | --- 1/4 of --- 1/4 SECTION _____ | TOWNSHIP _____ | <input type="checkbox"/> N <input type="checkbox"/> S RANGE _____ | <input type="checkbox"/> E <input checked="" type="checkbox"/> W | --- 1/4 of --- 1/4 SECTION _____ | TOWNSHIP _____ | <input type="checkbox"/> N <input type="checkbox"/> S RANGE _____ | <input type="checkbox"/> E <input checked="" type="checkbox"/> W | --- 1/4 of --- 1/4 SECTION _____ | TOWNSHIP _____ | <input type="checkbox"/> N <input type="checkbox"/> S RANGE _____ | <input type="checkbox"/> E <input checked="" type="checkbox"/> W |
| E 1/2 of --- 1/4 SECTION <u>29</u> | TOWNSHIP <u>13</u> | <input type="checkbox"/> N <input checked="" type="checkbox"/> S RANGE <u>65</u> | <input type="checkbox"/> E <input checked="" type="checkbox"/> W | | | | | | | | | | | | | | | | | | | | | | | | |
| --- 1/4 of --- 1/4 SECTION _____ | TOWNSHIP _____ | <input type="checkbox"/> N <input type="checkbox"/> S RANGE _____ | <input type="checkbox"/> E <input checked="" type="checkbox"/> W | | | | | | | | | | | | | | | | | | | | | | | | |
| --- 1/4 of --- 1/4 SECTION _____ | TOWNSHIP _____ | <input type="checkbox"/> N <input type="checkbox"/> S RANGE _____ | <input type="checkbox"/> E <input checked="" type="checkbox"/> W | | | | | | | | | | | | | | | | | | | | | | | | |
| --- 1/4 of --- 1/4 SECTION _____ | TOWNSHIP _____ | <input type="checkbox"/> N <input type="checkbox"/> S RANGE _____ | <input type="checkbox"/> E <input checked="" type="checkbox"/> W | | | | | | | | | | | | | | | | | | | | | | | | |
| --- 1/4 of --- 1/4 SECTION _____ | TOWNSHIP _____ | <input type="checkbox"/> N <input type="checkbox"/> S RANGE _____ | <input type="checkbox"/> E <input checked="" type="checkbox"/> W | | | | | | | | | | | | | | | | | | | | | | | | |
| --- 1/4 of --- 1/4 SECTION _____ | TOWNSHIP _____ | <input type="checkbox"/> N <input type="checkbox"/> S RANGE _____ | <input type="checkbox"/> E <input checked="" type="checkbox"/> W | | | | | | | | | | | | | | | | | | | | | | | | |
| 8. PLAT – Location of all wells on property must be plotted and permit numbers provided | | | | | | | | | | | | | | | | | | | | | | | | | | | |
| Surveyors plat <input type="checkbox"/> Yes <input type="checkbox"/> No | | If not, scaled hand drawn <input type="checkbox"/> Yes <input checked="" type="checkbox"/> No No Wells | | | | | | | | | | | | | | | | | | | | | | | | | |
| 9. ESTIMATED WATER REQUIREMENTS – Gallons per day or Acre Feet per Year | | 10. WATER SUPPLY SOURCE | | | | | | | | | | | | | | | | | | | | | | | | | |
| HOUSEHOLD USE (inc. lot irr) _____ GPD <u>21.7</u> AF COMMERCIAL USE _____ GPD _____ AF IRRIGATION _____ GPD _____ AF STOCK WATERING _____ GPD _____ AF OTHER _____ GPD _____ AF TOTAL _____ GPD <u>21.7</u> AF | <table border="1" style="width: 100%; border-collapse: collapse;"> <tr> <td style="width: 50%; padding: 5px;"> <input type="checkbox"/> EXISTING WELLS <input type="checkbox"/> DEVELOPED SPRINGS WELL PERMIT NUMBERS _____ _____ _____ </td> <td style="width: 50%; padding: 5px;"> <input type="checkbox"/> NEW WELLS – Proposed <input type="checkbox"/> Alluvial <input type="checkbox"/> Upper Arapahoe <input type="checkbox"/> Upper Dawson <input type="checkbox"/> Lower Arapahoe <input type="checkbox"/> Lower Dawson <input type="checkbox"/> Laramie Fox Hills <input type="checkbox"/> Denver <input type="checkbox"/> Dakota <input type="checkbox"/> Other _____ </td> </tr> <tr> <td style="padding: 5px;"> <input checked="" type="checkbox"/> MUNICIPAL <input type="checkbox"/> ASSOCIATION <input type="checkbox"/> COMPANY <input type="checkbox"/> DISTRICT NAME Cherokee Metropolitan District LETTER OF COMMITMENT FOR SERVICE <input checked="" type="checkbox"/> YES <input type="checkbox"/> NO </td> <td style="padding: 5px;"> WATER COURT DECREE CASE NO. _____ </td> </tr> </table> | | <input type="checkbox"/> EXISTING WELLS <input type="checkbox"/> DEVELOPED SPRINGS WELL PERMIT NUMBERS _____ _____ _____ | <input type="checkbox"/> NEW WELLS – Proposed <input type="checkbox"/> Alluvial <input type="checkbox"/> Upper Arapahoe <input type="checkbox"/> Upper Dawson <input type="checkbox"/> Lower Arapahoe <input type="checkbox"/> Lower Dawson <input type="checkbox"/> Laramie Fox Hills <input type="checkbox"/> Denver <input type="checkbox"/> Dakota <input type="checkbox"/> Other _____ | <input checked="" type="checkbox"/> MUNICIPAL <input type="checkbox"/> ASSOCIATION <input type="checkbox"/> COMPANY <input type="checkbox"/> DISTRICT NAME Cherokee Metropolitan District LETTER OF COMMITMENT FOR SERVICE <input checked="" type="checkbox"/> YES <input type="checkbox"/> NO | WATER COURT DECREE CASE NO. _____ | | | | | | | | | | | | | | | | | | | | | |
| <input type="checkbox"/> EXISTING WELLS <input type="checkbox"/> DEVELOPED SPRINGS WELL PERMIT NUMBERS _____ _____ _____ | <input type="checkbox"/> NEW WELLS – Proposed <input type="checkbox"/> Alluvial <input type="checkbox"/> Upper Arapahoe <input type="checkbox"/> Upper Dawson <input type="checkbox"/> Lower Arapahoe <input type="checkbox"/> Lower Dawson <input type="checkbox"/> Laramie Fox Hills <input type="checkbox"/> Denver <input type="checkbox"/> Dakota <input type="checkbox"/> Other _____ | | | | | | | | | | | | | | | | | | | | | | | | | | |
| <input checked="" type="checkbox"/> MUNICIPAL <input type="checkbox"/> ASSOCIATION <input type="checkbox"/> COMPANY <input type="checkbox"/> DISTRICT NAME Cherokee Metropolitan District LETTER OF COMMITMENT FOR SERVICE <input checked="" type="checkbox"/> YES <input type="checkbox"/> NO | WATER COURT DECREE CASE NO. _____ | | | | | | | | | | | | | | | | | | | | | | | | | | |
| 11. ENGINEER'S WATER SUPPLY REPORT <input checked="" type="checkbox"/> YES <input type="checkbox"/> NO IF YES, PLEASE FORWARD WITH THIS FORM. | | | | | | | | | | | | | | | | | | | | | | | | | | | |
| 12. TYPE OF SEWAGE DISPOSAL SYSTEM | | | | | | | | | | | | | | | | | | | | | | | | | | | |
| <input type="checkbox"/> SEPTEC TANKLEACH _____ <input type="checkbox"/> LAGOON _____ <input type="checkbox"/> ENGINEERED SYSTEM (Attach a copy of engineering design) | | <input checked="" type="checkbox"/> CENTRAL SYSTEM – DISTRICT NAME <u>Cherokee Metropolitan District</u> <input type="checkbox"/> VAULT – LOCATION SEWAGE HAULED TO _____ <input type="checkbox"/> OTHER _____ | | | | | | | | | | | | | | | | | | | | | | | | | |