

4/15/22

Owner

Craig and Sally McDermott
12830 Herring Rd., Colorado Springs, CO 80908
craigmcderm@hotmail.com
719-495-6679

Applicant

Scott McDermott
6417 S. Dallas Ct., Englewood, CO 80111
scottmcou812@hotmail.com
303-358-7234

Site Information:

Legal Description: N 990 FT OF NE4SE4 EX E 30 FT SEC 8-12-65

THE NORTH THREE-FOURTHS OF THE NORTHEAST QUARTER OF THE SOUTHEAST QUARTER OF SECTION 8, TOWNSHIP 12 SOUTH, RANGE 65 WEST OF THE 6TH PRINCIPAL MERIDIAN, COUNTY OF EL PASO, STATE OF COLORADO.

Parcel #: 5208000030

<https://property.spatalest.com/co/elpaso/#/property/5208000030>

29.32 Acres

Zoned RR-5 (Rural Residential District)

Property currently is a vacant site with a single-family residence and an extended family dwelling on the center-east portion of the parcel. The existing land uses in the area are of rural residential/agriculture parcels improved with homes.

12930 HERRING RD Minor Subdivision Letter of Intent

3 lots will be created.
Update throughout
LOI

Request:

The Owner/Applicant requests approval of a two, 5 acre lot and one, 20 acre lot minor subdivision of the Property to be known as the 12830 Herring Rd. property (“Subdivision”). The Subdivision will create three new rural residential single family lots in the RR5 zone, with each lots at or exceeding the 5 acres minimum. Lot 1 will be the remaining 19.525 acre with the original residences. Lot 2 will be a 5 acre lot located at the northwest corner of the property and will be retained by the owner. Lot 3 is a 5 acres lot located at the southwest corner of the property and will be sold to the owner’s brother Scott McDermott upon the completion of the subdivision so he can build a single family home.

There is not legal physical access to both new Lots (2 & 3) proposed as they are, so we are seeking a waiver for Section 7 subdivision regulations to allow a lot without any public roadway frontage. To create legal physical access to new Lots 2 & 3, the owner proposes to put in place an Access and Utility Easement and Maintenance Agreement for driveway and utility access across the North border of Lot 1 and East border of Lot 2 to benefit Lots 2 & 3 as shown in the Final Plat. Driveway access will be from Herring Rd., which is East of the property. Access to the 2 new lots will be a private driveway on the North side of Lot 1. The drive will then run along the East side of Lot 2 for access to Lot 2 and Lot 3.

As background, the entire 29.32 acre property was a total loss of forest and structures in the 2013 fire. All of the structures and more have been rebuilt since the 2013 fire.

Justification:

The proposed 12930 HERRING RD Minor Subdivision is in conformance with all El Paso County requirements for creation of a minor subdivision. The proposal is consistent with the RR5 zoning and is compatible with the surrounding neighborhood zoned RR5, which consists of large lots or parcels of at least 5 acres in size.

The Property contains a single family residence with an extended family dwelling, which are located on Lot 1. Lot 2 and Lot 3 are on the western portion of the Property. The proposed layout of the subdivision will comply with the requirements of the RR5 zone with respect to land use (single-family residential), lot size, minimum building setbacks, water supply and wastewater disposal.

The Property was purchased by the Owner/Applicant from his father who purchased the 29.32 acre property with the intent of being utilized by his family in 1969. The Owner and his brother (Applicant), who will be purchasing Lot 3, intend to share the care for elderly parents, which live 8.3 miles from the property.

Criteria for Approval:

The Subdivision complies with all requirements for approval of a minor subdivision contained in

Section 7.2.1 (C) and the plans and standards set forth in Chapter 8 of the County Land Development Code (“Code”). Section 7.2. 1 (c) states that a minor subdivision shall be required to conform to all preliminary plan and final plat requirements including the criteria for approval, except to the extent the requirements are modified by the Code or the Procedures Manual.

Preliminary Plan Approval Criteria

The Subdivision meets all criteria for approval under Section 7.2.1 (D) (2) of the Code for preliminary plan approval and sections of Chapters 6 and 8 of the Code as follows:

- The Subdivision is consistent with the purposes of the Code.
- The Subdivision is in conformance with the subdivision design standards.
- As shown in the Engineered water reports submitted as part of the application, a sufficient water supply has been acquired in terms of quantity, quality and dependability for the proposed minor subdivision, as determined in accordance with the standards set forth in the water supply standards (C.R.S. § 30-28-133 (6) (a)) and the requirements of Chapter 8 of the Code.
- The septic system for the existing residence and the septic system proposed for the new home meet all criteria of Chapter 8 of the Code and is in compliance with state and local laws and regulations, per C.R.S. § 30-28-133 (6) (b).
- Any soil or topographical conditions presenting hazards or requiring special precautions were identified in the accompanying geology and soils reports and to the extent identified, the Subdivision is compatible with such conditions. per C.R.S. § 30-28-133 (6) (c).
- Adequate drainage improvements complying with State law (C.R.S. § 30-28-133 (6)(C)(VIII)) and the requirements of the Code and the ECM are provided with the design of the Subdivision.
- As there are no public improvements proposed in connection with the Subdivision, no determination of the adequacy of the location and design of any public improvements is required.
- The Subdivision has established an adequate level of compatibility by incorporating natural physical features in the design. As there will only one single family residence planned for the two new 5 acre subdivisions (Lot2 & Lot 3) with Lot 1 being 20 acres which will be sufficient open spaces. The Subdivision’s site planning techniques will foster the implementation of the County’s plans. Physical design features of the Subdivision will remain consistent with the adjacent land uses and will remain rural residential. Any environmentally sensitive areas in the Subdivision have been identified and incorporated into the Subdivision design. The Subdivision will not negatively impact the levels of service of County services and facilities.
- Necessary services, including police and protection, recreation, utilities, open space and transportation system, are available to serve the Subdivision.
- (New Section Added) There is not legal and physical access to both new Lots (2 & 3) proposed as they are, so we are seeking a waiver for Section 7 subdivision regulations to allow a lot without any public roadway frontage. To create legal physical access to new Lots 2 & 3, the owner proposes to put in place with a Access and Utility Easement and Maintenance Agreement across the North border of Lot 1 and East border of Lot 2 to benefit Lots 2 & 3 as shown in the Final Plat and Recorder with the county and referenceable with the El Paso County Clerk and Recorder Reception #: 222051376.

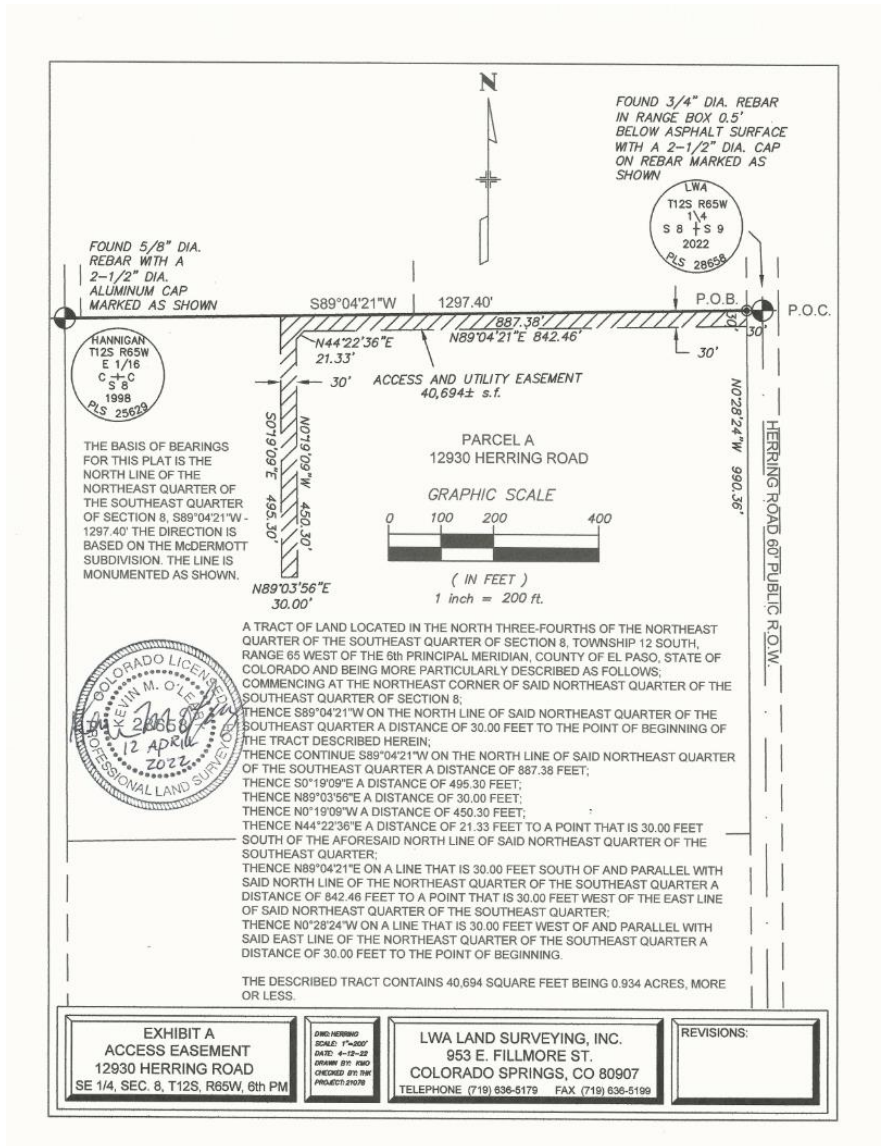

The new driveway off of Herring Road that will be shared by Lot 2 & Lot 3 will meet Land Development Code Section 6.3.3.C.2 & 6.3.3.C.3 & 6.3.3.C.4 including:

- A 24' gravel road for substantially all of the driveway from the entrance on Herring Road to both Lot 2 & Lot 3 shown on the Easement Exhibit. This allows for two way traffic on substantially all of the approximately 1,383' driveway to both properties.
- There will be 30' by 30' turn outs included in both sections of the driveway.
- The road will be rated to carry a 75,000 pound vehicle per the fire department requirement.
- No grades on this driveway will exceed 10 percent.
- There is no plan for a gate at this time, but if we do build a gate, we will adhere to LDC Section 6.3.3.C.4 requirements.
- There are no trees and not entry way portico for overhead clearance concern.

- Roads or emergency vehicle lanes shall be provided within 150 feet of all development except single family residential development.
- The dead end of the driveway will be at the Lot 3 residence. The dead-end turnaround at the terminus shall have a minimum radius of 50 feet.
- The 90 Degree turn has the appropriate easement to build the road with a curve that will allow large emergence appropriate turning radius.

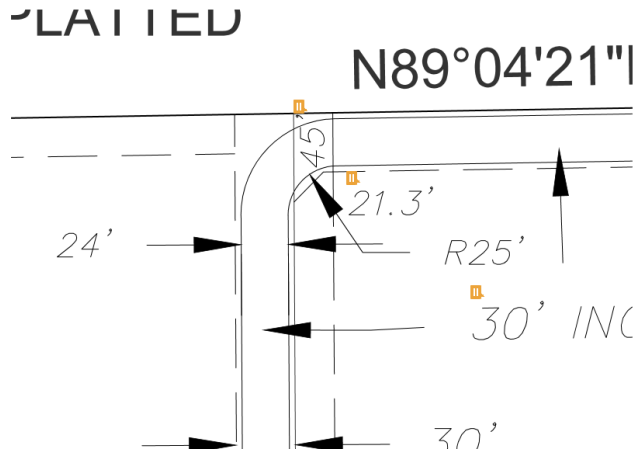

Completely revise master plan section and use newly adopted county master plan this can be found on the El Paso County website

Final Plat Approval Criteria:

The Subdivision meets all criteria for approval under Section 7.2.1 (D) (3) of the Code for final plat approval, as follows:

The Subdivision is in conformance with the goals, objectives and policies contained in the County Master Plan, including the Policy Plan, and it is in compliance with the County’s Water Master Plan. The Black Forest Preservation Plan (the “Plan”) is the Small Area Plan under the County Master Plan that provides guidelines for land use in the Black Forest area, including the Property.

1. The Subdivision is in conformance with the goals, objectives, and policies of the Master Plan and Policy Plan.

An element of the Master Plan is the Policy Plan, which establishes goals and policies in connection with approval of new development in the County. The McDermott Minor Subdivision proposal satisfies the following goals and policies from the Policy Plan:

Goal 1.1 - Ensure compatibility with established character and infrastructure capacity.

Goal 2.2 - Preserve the character of rural and environmentally sensitive areas.

Goal 2.2 - Preserve the character of rural and environmentally sensitive areas.

The proposed minor subdivision is compatible with adjacent properties, all of which are Large-Lot Residential of at least 5 acres in size, and located within the Forested Black Forest area.

These properties are rural residential in character and do not negatively impact the natural environment. The existing natural environment on the Property will be preserved following approval of this subdivision using mitigation and landscaping to maintain the properties natural environment.

Goal 3.1 - Recruit new businesses and spur the development of growing sectors.

The proposal will subdivide an existing 29.32 acre parcel into three lots, which will only increase the number of homes on the Property from one to three with the possibility of a third house sometime in the future. There will be limited impact on the existing carrying capacity of the area by the addition of three lots upon approval of the minor subdivision. The lot sizes of the three lots exceed the minimum 5-acre size required under RR5 zoning, and will ensure the existing rural residential nature of the area is maintained. Water for the second lot (Lot 3) has been adjudicated with the State, the well for the existing residence has been re-permitted, and a well permit for the new residence has been authorized.

2. The Subdivision meets goals and policies set forth in the Black Forest Preservation Plan.

The Property is within the planning area of the Plan, and more specifically, within the “Timbered Area” unit defined by the Plan. Uses in the Timbered Area are generally limited to low density residential or open space.

3. Residential - Goal 3.A - Promote a residential environment which perpetuates the rural residential character of the Black Forest Planning Area.

Policy 3.1 – Continue the promotion of residential subdivisions with an overall average minimum lot area of 5 acres in the Timbered Area and other designated portions of the Planning Area....

8. Natural Environment – Goal 8.A – Protect the integrity of the natural systems in the Black Forest.

Policy 8.1 – Preserve and enhance the natural environment and wildlife of the planning area.

Policy 8.2 – Protect and maintain the area’s drainage courses in their natural condition by promoting designs and densities which are sensitive to natural drainage patterns.

The minor subdivision will preserve the rural-residential character of the Black Forest Planning Area. The lot sizes will be 5 acres required under the RR5 zoning, with Lot 1 being 19.525 acres and Lot 2 being 5.003 acres and Lot 3 being 5.003 acres. The Property contains a single family home and an extended family dwelling. Upon approval of the minor subdivision, the Owner/Applicant will build one residence on Lot 3, which is sited in the Southwest corner of the property which will preserve a majority of the open space and all the future forested areas (2013 fire burned all the trees). As shown in the final drainage report submitted for this application, there are no special easements required for drainage.

3. The Subdivision meets the goals and policies set forth in the El Paso County Water Master Plan.

Goal 1.1 Ensure an adequate water supply in terms of quantity, dependability and quality for existing and future development.

Policy 1.1.1 – Adequate water is a critical factor in facilitating future growth and it is incumbent upon the County to coordinate land use planning with water demand, efficiency and conservation.

As part of this land use planning action, Owner/Applicant has demonstrated the quantity, dependability and quality of the water to be utilized in this development, demonstrating adequate water quality through testing, and adequacy and sufficiency of supply consistent with the County's 300-year rule concerning water supplies. Use of shallow Dawson aquifer groundwater, as contemplated here, is typical of rural residential lots in Black Forest, and further consistent with the Water Master Plan as concerns rural residential lots where municipal or quasi-municipal water supplies are unavailable.

The new lots (Lot 2 & Lot 3) have a total of 1.3 Acre feet of water use per year from the Dawson Aquifer. Household use of 0.3 AF/year per lot, Irrigation demand 0.3 AF/year per lot and 0.05 AF/year for domestic animals for a total of 1.30 Acre feet total for both lots.

Goal 4.3 Collaborate with the State and other stakeholders to extend the economic life of the Denver Basin aquifers.

Policy 4.3.1 – Denver Basin groundwater should be preserved as much as practical through water conservation and efficiency, extending the economic useful life.

Policy 4.3.2 – Encourage the systematic monitoring and careful administration of the bedrock aquifers to avoid over-allocation of groundwater.

Owner/Applicant, consistent with the County's 300-year rule, seeks a long-term sustainable use of the Dawson aquifer, consistent with local historical practices and vested property rights in the underlying Denver Basin aquifers. Such uses will prolong the economic life of not only the Dawson aquifer to be utilized in the Subdivision, but also deeper underlying Denver Basin aquifers available to the Owner/Applicant which are not to be utilized as part of the primary water source for this Subdivision.

Goal 5.5 Identify any water supply issues early on in the land development process.

Policy 5.5.1 – Discourage individual wells for new subdivisions with 2.5 acre or smaller average lot sizes, especially in the near-surface aquifers, when there is a reasonable opportunity to connect to an existing central system, alternatively, or construct a new central water supply system when the economies of scale to do so can be achieved.

Goal 5.6 Protect property rights.

The Subdivision proposed at this site concerns approximately 5, 5 and 20 acre lots, considerably larger than those for which individual wells are to be discouraged under the WMP, and there currently is no opportunity in this location to connect to an existing system or construct a new

central system. Approval of individual wells in this circumstance protects the vested property rights of Owner/Applicant.

Goal 6.0 Require adequate water availability for proposed development.

Policy 6.0.1 – Continue to require documentation of the adequacy or sufficiency of water, as appropriate, for proposed development.

As described above, and in the Water Resources Report and Water Quality Report, adequacy and sufficiency of water for the proposed development, for a period of at least 300-years, has been documented and demonstrated. See also WMP p. 111 (“El Paso County understands that each landowner has property rights, and, in many cases, those property rights include water rights. The County’s goal is not to infringe on those rights, but to assure sufficient water supplies are available to foster a sustainable place for people to live and work”).

The Subdivision is consistent with the design standards and regulations and meets all planning, engineering and surveying requirements of the County for maps, data, surveys, analyses, studies, reports, plans, designs, documents, and other supporting materials.

- As shown in the water reports submitted as part of the application, a sufficient water supply has been acquired in terms of quantity (1.3 acre feet per lot per year), quality (tested and passed all quality reports for safe drinking) and dependability for the proposed minor subdivision, as determined in accordance with the standards set forth in the water supply standards (C.R.S. § 30-28-133 (6) (a)) and the requirements of Chapter 8 of the Code.
- The septic system for the existing residence and the septic system proposed for the new home meet all criteria of Chapter 8 of the Code and is in compliance with state and local laws and regulations, per C.R.S. § 30-28-133 (6) (b). Lot 1 septic system is an engineered septic system due to clay levels, and test pits from holes for lot 2 will also need to be an engineered septic system.
- Any soil or topographical conditions presenting hazards or requiring special precautions were identified in the accompanying geology and soils reports and to the extent identified, the Subdivision is compatible with such conditions. per C.R.S. § 30-28-133 (6) (c). The surveyor and engineer did find 4.003 acres across lot 1 and 2 as geo Hazard/ Drainage Easements that are no build areas, but will not impact either proposed site.
- Adequate drainage improvements complying with State law (C.R.S. § 30-28-133 (6)(C)(VIII)) and the requirements of the Code and the ECM are provided with the design of the Subdivision. Culvert has already been installed in lot 1 for driveway access and will also be assessed for lot 2 driveway per standards.

New legal physical access will be provided for both new Lots (2 & 3). We are seeking a waiver for Section 7 subdivision regulations to allow a new public roadway frontage. To create legal physical access to new Lots 2 & 3, the owner has put in place an Access and Utility Easement and Maintenance Agreement across the North border of Lot 1 and East border of Lot 2 to benefit Lots 2 & 3 as shown in the Final Plat. Driveway access will be from Herring Rd., which is East

of the property. Access to the 2 new lots will be a private driveway on the North side of Lot 1. The drive will then run along the East side of Lot 2 for access to Lot 2 and Lot 3. Herring road is a paved road that is designated as a north-south through connecting Hodgen on the north, to Burgess Rd on the south. Detail driveway description provided previously.

Necessary services, including police and protection, recreation, utilities, open space and transportation system, are available to serve the Subdivision.

- The final plans of the Subdivision show that the proposed methods for fire protection comply with Section 6 of the Code as there is no forest left after the 2013 fire. Therefore, there is no reason for a Wildland Mitigation Report.
- Off-site impacts of this Subdivision are addressed below. No mitigation for off-site impacts are necessary under the applicable requirements of Chapter 8.
- To the Owner/Applicant's knowledge, no public facilities or infrastructure, or cash-in-lieu, for impacts reasonably related to the Subdivision, are required.
- The Subdivision meets other applicable sections of Chapters 6 and 8.
- The subdivision will not interfere with the extraction of any known commercial mining deposit.

Public Improvements

There are no required public subdivision improvements required for the Subdivision. The Property has frontage along Herring Road, where county required right of way will be maintained.

Respectfully,



Scott McDermott

Applicant commits to pay road impact fees, which will be due as part of the building permit for new construction on lots.