

STORMWATER MANAGEMENT PLAN
for
FALCON SHERIFF SUBSTATION
10262 Royal County Down Rd.
Falcon, Colorado

October 5, 2023

Prepared For:

El Paso County

Prepared by:

Drexel, Barrell & Co.

101 Sahwatch St., Suite 100

Colorado Springs, CO 80903

Contact: Tim McConnell, P.E.

(719) 260-0887

Qualified Stormwater Manager

TBD

Contractor:

TBD

**STORMWATER MANAGEMENT PLAN
FALCON SHERIFF SUBSTATION**

TABLE OF CONTENTS

| | | |
|------------|---|-----------|
| 1.0 | STORMWATER QUALITY STATEMENT & OBJECTIVES | 2 |
| 2.0 | SITE DESCRIPTION..... | 2 |
| 2.1 | DESCRIPTION OF CONSTRUCTION ACTIVITIES..... | 2 |
| 2.2 | EXISTING SITE CONDITIONS | 2 |
| 2.3 | ADJACENT AREAS..... | 3 |
| 2.4 | SOILS..... | 3 |
| 2.5 | AREAS AND VOLUME STATEMENT | 3 |
| 2.6 | CONTROLS AND MEASURES DURING CONSTRUCTION..... | 3 |
| 2.7 | POTENTIAL POLLUTION SOURCES | 6 |
| 2.8 | NON-STORMWATER DISCHARGES..... | 7 |
| 2.9 | RECEIVING WATER | 8 |
| 3.0 | GRADING & EROSION CONTROL PLA..... | 8 |
| 4.0 | BMP's FOR STORMWATER POLLUTION PREVENTION | 9 |
| 4.1 | EROSION CONTROL – STRUCTURAL PRACTICES..... | 9 |
| 4.2 | EROSION CONTROL – NON-STRUCTURAL PRACTICES..... | 11 |
| 4.3 | MATERIALS HANDLING & SPILL PREVENTION..... | 11 |
| 4.4 | DEDICATED CONCRETE OR ASPHALT BATCH PLANTS..... | 12 |
| 4.5 | GROUNDWATER & STORMWATER DEWATERING | 12 |
| 5.0 | TIMING SCHEDULE..... | 13 |
| 6.0 | FINAL STABILIZATION AND LONG-TERM STORMWATER MANAGEMENT..... | 13 |
| 7.0 | INSPECTION AND MAINTENANCE..... | 14 |
| 8.0 | REFERENCES | 15 |

APPENDICES

| | |
|--------------------------------------|-------------------|
| VICINITY MAP | APPENDIX A |
| SOILS INFORMATION | APPENDIX B |
| SITE MAP | APPENDIX C |
| INSPECTION FORM TEMPLATE..... | APPENDIX D |

1.0 STORMWATER QUALITY STATEMENT & OBJECTIVES

Stormwater quality best management practices shall be implemented to minimize soil erosion, sedimentation, increased pollutant loads and changed water flow characteristics resulting from land disturbing activity, to the maximum extent practicable, so as to minimize pollution of receiving waters.

Per Appendix A of the Colorado Department of Health, Water Quality Control Division's (the Division) "General Permit Application for Stormwater Discharge Associated with Construction Activities", the goal of the Stormwater Management Plan (SWMP) is:

"To identify possible pollutant sources that may contribute pollutants to stormwater, and identify Best Management Practices (BMPs) that, when implemented, will reduce or eliminate any possible water quality impacts. The SWMP must be completed and implemented at the time the project breaks ground, and revised if necessary as construction proceeds to accurately reflect the conditions and practices at the site."

This document is not intended to address training, site specific operational procedures, logistics, or other "means and methods" required to construct this project.

This document must be kept at the construction site at all times. Inspections are to be made at least every 14 days and after any precipitation event, or snowmelt that causes surface erosion. El Paso County requires that the inspector be contacted 48 hours prior to initial and final inspections. An inspection log entry shall be completed with each inspection performed. The inspection log shall be kept with the SWMP. The conditions of the SWMP and General Permit for Stormwater Discharges associated with the construction activity will remain in effect until final stabilization is achieved, and a notice of inactivation is sent to CDPHE Stormwater Quality Division. All pertinent records must be kept for at least 3 years from the date the site is stabilized.

This SWMP shall be viewed as a “living document” that is continuously being reviewed and modified as part of the overall process of evaluating and managing stormwater quality issues at the site. The Qualified Stormwater Manager (QSM) shall amend the SWMP when there is a change in the design, construction, Operations and Maintenance (O&M) of the site which would require the implementation of new or revised BMPs, or if the SWMP proves to be ineffective in achieving the general objectives of controlling pollutants in stormwater discharges associated with construction activity, or when BMPs are no longer necessary and are removed.

Drexel, Barrell & Co. has been retained to provide civil engineering services for the design of this project. Drexel, Barrell & Co. is not responsible for implementation and maintenance of the Stormwater Management Plan.

2.0 SITE DESCRIPTION

2.1 DESCRIPTION OF CONSTRUCTION ACTIVITIES

The project involves the development of Falcon Sheriff Substation in Falcon, CO. The total site area consists of approximately 2.37 acres of political subdivision with landscaping and parking areas.

2.2 EXISTING SITE CONDITIONS

The overlot grading, roadway, utility infrastructure and detention facility installation will be completed prior to the start of development for the Woodmen Hills Sheriff Substation. As determined by visual inspection, reseeding associated with the overlot grading will be completed. Sparse grasses and vegetation currently covers approximately 100% of the site. The west side of the site generally follows a 1%-2% grade from west to east and the north side generally follows a 5-7% grade from north to south. Both drain directly into the water quality/detention facility located on the southern side of the neighboring fire station.

2.3 ADJACENT AREAS

The site is bounded on the north by Stapleton Drive and the south by Royal County Down Road, to the east is the Woodmen Hills Fire Station and the west by the Winged Foot Road neighborhood. The surrounding areas should not be affected by the land disturbing and stabilization activities.

2.4 SOILS

From the Natural Resources Conservation Service (NRCS), the soil on the site as mapped by the Soil Conservation Service (SCS) is the Columbine gravelly sandy loam (Soil No. 19). The soil is apart of hydrologic group A, with moderate erosion potential. Hydrologic Soil Group A soils have a high infiltration rate when thoroughly wet. These consist mainly of deep, well drained to excessively drained sands or gravelly sands. These soils have a high rate of water transmission. Potential effects of soil erosion include compaction, loss of soil structure, nutrient degradation, soil salinity and increased sediment load downstream.

2.5 AREAS AND VOLUME STATEMENT

The project site consists of approximately 2.37 acres. Unadjusted overlot earthwork volumes within the construction site are approximately 1300 CY of cut and 210 CY of fill. The entire disturbed area covers 2.0-acres, however the disturbed areas drain to separate locations as described below. The central portion of the site disturbed area (0.98-acres) drains to a proposed curb inlet located on the south side of the building plaza. This area will be captured by a proposed storm drain and discharged to the existing water quality pond. The north and easterly disturbed area (0.57-acres) will follow the existing drainage pattern directly to the existing water quality pond. The remaining disturbed area consists of landscaped area and will discharge directly offsite.

2.6 CONTROLS AND MEASURES DURING CONSTRUCTION

Stabilization activities are anticipated to begin in the Fall of 2023. A construction schedule will be prepared by the contractor prior to land disturbing activities. Phasing of the installation of stabilization measures will be required. Reference the attached Grading

and Erosion Control plans in the appendix for site specific locations and phasing. The general sequence of major construction activities is as follows:

1. Temporary Erosion Control Measures – Temporary erosion control measures, such as silt fence and construction of a vehicle tracking pad and staging area will be completed prior to any other large scale activity. The vehicle tracking pad will ensure a reduction of tracking of soil on and off the construction site. The staging area will house the materials, petroleum product storage (if any), trash dumpster, sanitary facilities and hazardous spill clean-up areas. These are all potential pollutants that are not sediment related.
2. Trash and Debris Removal – Existing trash and debris shall be removed from the site and hauled to designated receiving facility.
3. Site Clearing – The area to be disturbed for construction will be cleared and grubbed, as necessary to the perimeter of erosion control. The sequence of the areas to be cleared and grubbed are subject to the contractor's means and methods of construction of the site; however, the general plan is to work from the south to north where the vehicle tracking pads are located in order to eliminate backtracking over areas that have already been completed.
4. Overlot Grading – Overlot grading will occur to bring the site to the proposed sub-grade elevations in paved areas, and to finished grade elevations in the landscape and detention areas. Spoils from the site will be removed from the site and hauled to a designated receiving facility or location.
5. Utility Installation – Utility installation will consist of water, sanitary sewer, electric, and telephone and natural gas service lines. Storm drain lines will also be installed. Utility locations will be obtained prior to commencement of construction activities.

6. Final Grading – The site will be brought to final elevations with the installation of the proposed paving and final blending to existing grades on the perimeter of the improvement area.
7. Permanent Re-vegetation – Erosion control blanket will be installed at all areas graded to a 3:1 slope and greater. Areas not paved will be re-vegetated and/or landscaped by the contractor or owner as per the approved landscape plan. Vegetation and stabilization of soil will aid in the trapping of sediment and reducing soil erosion.
8. Removal of Temporary BMP's – Temporary erosion control measures may be removed once the site has achieved final 70 percent of pre disturbance levels and vegetation cover is capable of reducing soil erosion. All permanent BMPs shall be cleaned and functioning before any temporary BMPs are removed.
9. Housekeeping – The best BMP for a job site is good housekeeping around the site.
 - 1) Routine site trash pickup and routine BMP inspection and maintenance are paramount for keeping a job site clean and tidy. Waste disposal bins shall be checked weekly for leaks and emptied weekly or as necessary to prevent overflowing capacity.
 - 2) All petroleum storage areas in the staging area should be checked daily for leaks. Any leaks shall be reported to the site foreman for clean up. All personnel on site for both the contractor and subcontractors should be briefed on spill cleanup and containment procedures. Employees shall also be briefed as to where the spill cleanup materials can be found if a spill should occur. The spill plan shall be produced by the general contractor for the project and remain onsite for the duration of the project. Contractor shall coordinate with the County to obtain the necessary contacts in the case that a spill occurs.

- 3) All portable toilets shall be located a minimum of 10ft from stormwater inlets and 50ft from State Waters. Portable toilets shall be secured at all four corners to prevent overturning, cleaned on a weekly basis and inspected daily for spills.

2.7 POTENTIAL POLLUTION SOURCES

Any substances with the potential to contaminate either the ground or ground surface water shall be cleaned up immediately following discovery, or contained until appropriate cleanup methods can be employed. Manufacturer's recommended methods for cleanup shall be followed, along with proper disposal methods. All waste and debris created by construction at the site or removed from the site shall be disposed of in accordance with all laws, regulations and ordinances of the Federal, State and local agencies. The following is a summary of potential pollution sources and their associated measures intended to minimize the risk of pollution for this project.

- 1) Disturbed and stored soils: Straw wattles/fiber rolls, straw bale check dams and gravel bag check dams, seed and mulch.
- 2) Vehicle tracking and sediments: VTC and Street Sweeping
- 3) Loading and unloading operations: Stabilized staging area, materials storage area, VTC and silt fence.
- 4) Outdoor storage of materials: Stabilized staging area, materials storage area and silt fence.
- 5) Vehicle and equipment maintenance and fueling: Spill prevention procedures.
- 6) Dust or particulate generation from earthmoving activities and vehicle movement: water trucks for site watering.
- 7) On site waste management of solid wastes (construction debris): Waste container placement, covering and disposal.

- 8) Concrete truck/equipment washing: Dedicated concrete washout areas.
- 9) Worker trash and portable toilets: Container placement, covering and disposal.
- 10) Equipment repair or maintenance beyond normal fueling operations: Spill prevention procedures.
- 11) Waste disposal: Container placement, covering and regular disposal. Containers are to be checked daily for capacity and emptied when 3/4-full. At a minimum containers are to be emptied weekly.
- 12) Off site soil tracking: Contractor to perform street sweeping following storm events and as required to keep adjoining public streets clean
- 13) Portable toilets will be located a minimum of 10-ft from stormwater inlets and 50-ft from State Waters. They will be secured at all four corners to prevent overturning and are to be cleaned on a weekly basis. They are to be inspected daily for spills.

The following items are not anticipated to be potential pollution sources for this project:

- 1) Management of contaminated soils.
- 2) Outdoor storage of fertilizers, chemicals or potentially polluting construction material.
- 3) Dedicated asphalt or concrete batch plants.

2.8 NON-STORMWATER DISCHARGES

Non-stormwater discharges possibly encountered during construction may include: watering down of the site, construction staging area, and excess dirt storage during high winds to minimize wind erosion and water utilized in soil compaction efforts. These will occur on a site-wide basis.

2.9 RECEIVING WATER

Runoff generated by the proposed project will be passed to the neighboring storm sewer system and detention pond prior to discharging into the existing of 24" RCP storm sewer that passes under Royal County Down Road and ultimately to Black Squirrel Creek.

No streams cross the project area.

3.0 GRADING & EROSION CONTROL PLAN

Attached as part of this plan is a Grading and Erosion Control Plan (See Appendix C). The drawings identify the following:

- 1) Project area boundary and areas of disturbance
- 2) Cut-Fill delineation lines
- 3) Area used for staging
- 4) Location of erosion control facilities or structures (BMP's)
- 5) Boundaries of 100-year floodplains (if applicable)

The following items may not be indicated on the attached drawings, but will be determined by the individual contractors prior to and during construction activities:

- 1) Areas used for storage of construction materials, soils, or wastes
- 2) Location of portable toilets and waste receptacles
- 3) Location of additional BMP's that may become necessary as work progresses
- 4) Location of construction fencing after coordination with adjacent property owner (Falcon Fire Department). Access to the Fire Station and associated parking is required to be maintained at all times.

These items shall be added to the Site Map by the Contractor.

4.0 BMP's FOR STORMWATER POLLUTION PREVENTION

Best management practices (BMPs) used throughout the site shall include, but are not limited to: surface roughening, silt fence, inlet protection, vehicle tracking control, mulching and reseeding and concrete washout.

4.1 EROSION CONTROL – STRUCTURAL PRACTICES

A list of the Structural BMP's for erosion and sediment control that may be implemented on the site to minimize erosion and sediment are as follows. Refer to the SWMP Drawings for installation and maintenance requirements and location for each structural BMP. For each BMP not shown, reference the Mile High Flood District (MHFD) standard details for reference.

1. Concrete Washout Area (CWA): A shallow excavation with a small perimeter berm to isolate concrete truck washout operations. This is an interim/final BMP intended to be utilized once overlot grading has been completed.
2. Construction Fence (CF): Installed to delineate the perimeter of the site. This is required at the initial stage or pre-disturbance. Construction fence is to remain until project completion or as otherwise determined by the contractor.
3. Drainage Swale/Earth Dike (DS): A small earth, riprap or erosion blanket lined channel used to divert and convey runoff. This is an initial/interim BMP designed for use during grading operations.
4. Erosion Control Blanket (ECB): Slopes steeper than or equal to 3 (horizontal) to 1 (vertical) shall be protected with an erosion control blanket. This is a final stabilization measure to be installed once grading is completed.
5. Inlet Protection (IP): Installed as an initial/interim measure to filter stormwater before entering any watercourses.
6. Reinforced Sock (RS): An initial/interim measure that consists of a linear mass of gravel enclosed in wire mesh to form a porous filter, able to withstand overtopping.
7. Sediment Basin (SB): An initial/interim measure consisting of an impoundment that captures sediment laden runoff and releases it slowly, providing prolonged settling times to capture coarse and fine grained soil particles.

8. Sediment Control Log (SCL): An initial/interim measure that consists of a cylindrical bundle of wood, coconut, compost, excelsior, or straw fiber designed to form a semi-porous filter able to withstand overtopping.
9. Seeding and Mulching (SM): As an interim measure temporary seeding and mulching can be used to stabilize disturbed areas that will be inactive for an extended period of time. As a final measure permanent seeding should be used to stabilize areas at final grade that will not otherwise be stabilized.
10. Silt Fence (SF): A temporary sediment barrier constructed of woven fabric stretched across supporting posts, used as an initial/interim measure.
11. Stabilized Staging Area (SSA): An initial/interim measure that consists of stripping the topsoil and spreading a layer of granular material in the area to be used for a trailer, parking, storage, unloading and loading.
12. Temporary Stockpile Areas (TS): An initial measure for use during grading operations that utilizes temporary stockpiles of excess excavated material and stockpiles for imported materials. Slopes shall not be steeper than 3 to 1.
13. Vehicle Tracking Control (VTC): Consists of a rock pad that is intended to help strip mud from tires prior to vehicles leaving the construction site. Installed as an initial/interim measure at all entrance/exit points to the site. The number of access points shall be minimized.

Minimal clearing and grubbing may be necessary prior to installing the initial erosion control features.

A pre-construction meeting with El Paso County must be held, initial BMPs installed, and a Notice to Proceed issued before any work can begin.

Once signoff and acceptance is received the approved erosion and sediment control measures must be installed before land-disturbing activities are initiated so that no adverse effect of site alteration will impact surrounding property.

4.2 EROSION CONTROL – NON-STRUCTURAL PRACTICES

Non-structural practices for erosion and sediment control to be used to minimize erosion and sediment transport are:

- a) Seeding and mulching and landscape installation in areas that will not be hard surfaced, while minimizing the amount of vegetation to be removed during construction, leaving native vegetation in place when possible.
- b) Street sweeping around the construction site will be utilized when tracking of mud occurs on paved streets. The sweeping will be required after any significant tracking has occurred; significant meaning any visible amount that cannot be completely cleaned by hand. The adjacent paved drive surfaces will be cleaned at the end of each day of construction activities. Sweeping efforts will continue as necessary until construction operations are completed.
- c) Site watering will be required to mitigate dust control and sediment and to aid in compaction.

4.3 MATERIALS HANDLING & SPILL PREVENTION

The SWMP administrator will inspect daily to ensure proper use and disposal of materials on site including building materials, paints, solvents, fertilizers, chemicals, waste materials and equipment maintenance or fueling procedures. All materials stored onsite will be stored in a neat and orderly manner in the original containers with the original manufacturer's label, and if possible under a roof or other enclosure to prevent contact with stormwater. Chemicals should be stored within berms or other secondary containment devices to prevent leaks and spills from contacting stormwater runoff. Before disposing of the container, all of a product will be used up whenever possible and manufacturer's recommendations for proper disposal will be followed according to state and local regulations.

Material and equipment necessary for spill cleanup will be kept in the material storage area on site. Manufacturer's recommendations for spill cleanup will be posted and site

personnel will be made aware of the procedures along with the location of the information and cleanup supplies.

The contractor shall have spill prevention and response procedures that include the following:

- a) Notification procedures to be used in the event of an accident. At the very least, the SWMP administrator should be notified. Depending on the nature of the spill and the material involved, the Colorado Department of Public Health and Environment (24-hour spill reporting line (877) 518-5608), downstream water users or other agencies may also need to be informed.
- b) Instructions for clean up procedures and identification of spill kit location(s).
- c) Provisions for absorbents to be made available for use in fuel areas and for containers to be available for used absorbents.
- d) Procedures for properly washing out concrete truck chutes and other equipment in a manner and location so that the materials and wash water cannot discharge from the site and never into a storm drain system or stream.

4.4 DEDICATED CONCRETE OR ASPHALT BATCH PLANTS

No dedicated concrete or asphalt batch plants will be used.

4.5 GROUNDWATER & STORMWATER DEWATERING

In the event that groundwater is encountered or stormwater enters an excavation and dewatering is necessary, a separate CDPHE construction discharge (dewatering) permit will be required for groundwater dewatering and shall be obtained by the SWMP administrator. During groundwater or stormwater dewatering, locations and practices to be implemented to control stormwater pollution from excavations, etc., must be noted on the SWMP. Construction dewatering cannot be discharged to surface water or to storm sewer systems without separate permit coverage. The discharge of Construction Dewatering water to the ground, under specific conditions, may be allowed by the

Stormwater Construction Permit when appropriate BMP's are implemented. Refer to USDCM Volume III (UDFCD) for County acceptable means of dewatering.

5.0 TIMING SCHEDULE

The project is anticipated to begin construction in the Spring of 2024 with final stabilization completion by Spring of 2026. The contractor shall be responsible for producing a schedule that will show at a minimum: start and completion times including site grading operations, utility construction and the removal of the temporary erosion and sediment control measures.

6.0 FINAL STABILIZATION AND LONG-TERM STORMWATER MANAGEMENT

Final stabilization shall not be considered complete until 70% of new or pre-existing vegetated cover condition is established on areas not to be hard-surfaced. Temporary sediment and erosion control measures installed prior to the construction phase will remain in place until this time. Any sediment that collects within the site's drainage system is considered unstabilized soil and must be removed prior to the site being considered finally stabilized.

At final stabilization, stormwater pollutants will be controlled by on site landscaping, source control best practices and by the water quality facility located on the adjacent lot.

The contractor will be responsible for any re-excavation of sediment or debris that collected in the existing water quality basin and are required to ensure that the basin meets the design grades following construction. The storm lines shall also be cleaned and free from sediment once the site becomes stabilized.

Inspections and maintenance as established by an updated Operations and Maintenance manual for the water quality facility will be required once the project reaches completion. The updated manual details the shared responsibility between the Fire Department and El Paso County (Sheriff) for the continued operations and maintenance of the facility.

7.0 INSPECTION AND MAINTENANCE

A site inspection of all erosion control facilities will be conducted every 14 days and within 24 hours after every precipitation event, or snowmelt event that causes surface erosion. The entrance to the construction site shall be inspected daily and existing street cleaned, as necessary, of all materials tracked out of the site.

The construction site perimeter, disturbed areas, and areas used for material storage that are exposed to precipitation shall be inspected for evidence of, or the potential for, pollutants entering the drainage system. Erosion and sediment control measures identified in the SWMP shall be observed to ensure that they are operating correctly.

Based on the results of the inspection, the description of potential pollutant sources and the pollution prevention and control measures that are identified in this plan shall be revised and modified as appropriate as soon as practicable after such inspection. Modification to control measures shall be implemented in a timely manner, but in no case more than seven (7) calendar days after the inspection.

The operator shall be responsible for documenting inspections and maintaining records. Uncontrolled releases of mud or muddy water or measurable quantities of sediment found off the site shall be recorded with a brief explanation as to the measures taken to prevent future releases as well as any measure taken to clean up the sediment that has left the site. All signed inspection record/logs should be kept on site and made available to the El Paso County or CDPHE personnel upon request.

All temporary and permanent erosion and sediment control facilities shall be maintained and repaired per manufacturer's specifications to assure continued performance of their intended function. Repairs should be completed within 24 to 48 hours. Silt fences may require periodic replacement.

8.0 REFERENCES

- [1] General Permit Application and Stormwater Management Plan Preparation Guidance for Stormwater Discharges Associated with Construction Activities. Prepared by the Colorado Department of Health, Water Quality Control Division. Revised 7/2009.
- [2] City of Colorado Springs– Drainage Criteria Manual, Volume 2 “Stormwater Quality Procedures and Best Management Practices (BMPs). November 1, 2002, amended August 10, 2010.
- [3] NRCS Web Soil Survey, www.websoilsurvey.nrcs.usda.gov

APPENDIX A
Vicinity Map

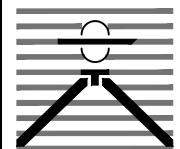
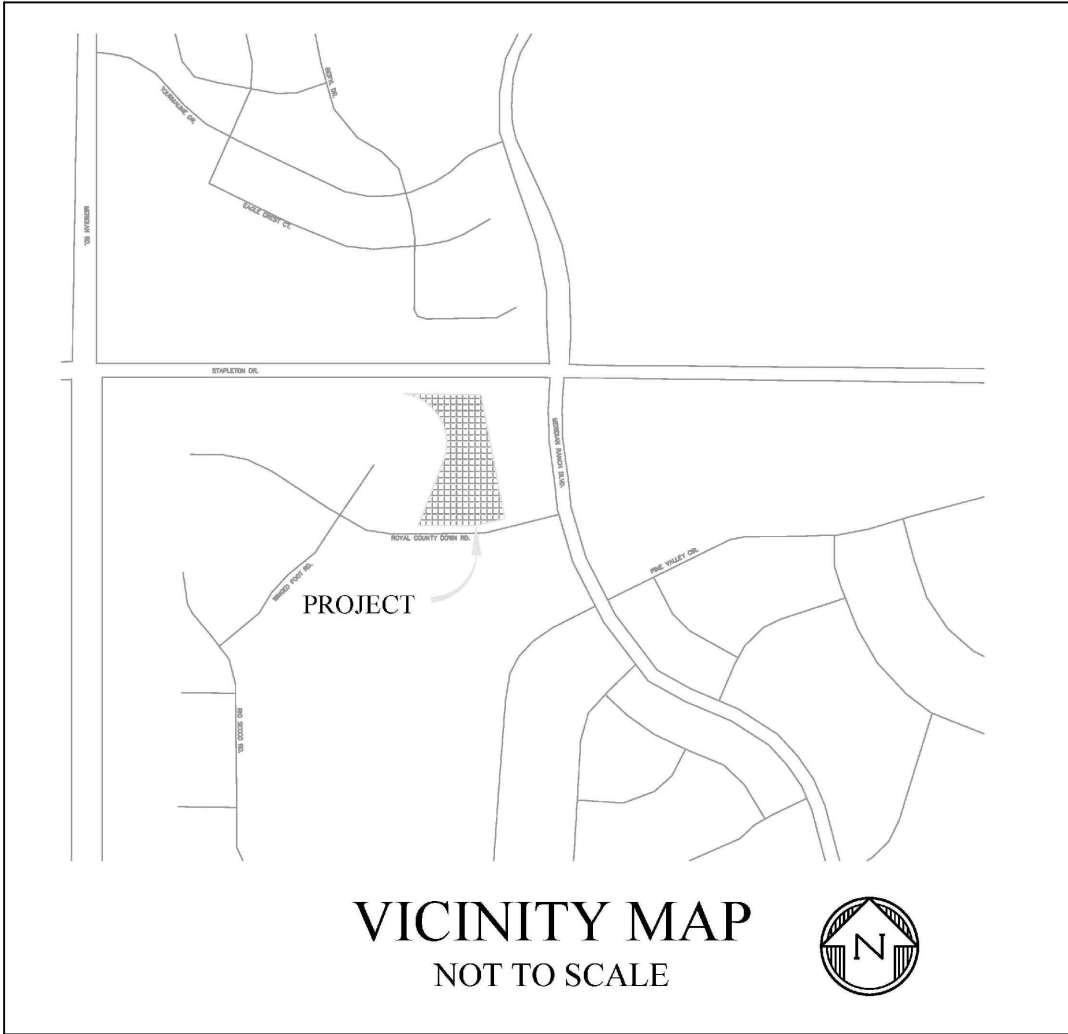

FALCON SHERIFF SUBSTATION
FALCON, CO
VICINITY MAP

| | |
|---|-------------|
| Drexel, Barrell & Co. Engineers • Surveyors | |
| DATE: | DWG. NO. |
| JOB NO: 21653-00CSCV | VMAP |
| SHEET 1 OF 1 | |

APPENDIX B
SOILS INFORMATION

Custom Soil Resource Report Soil Map

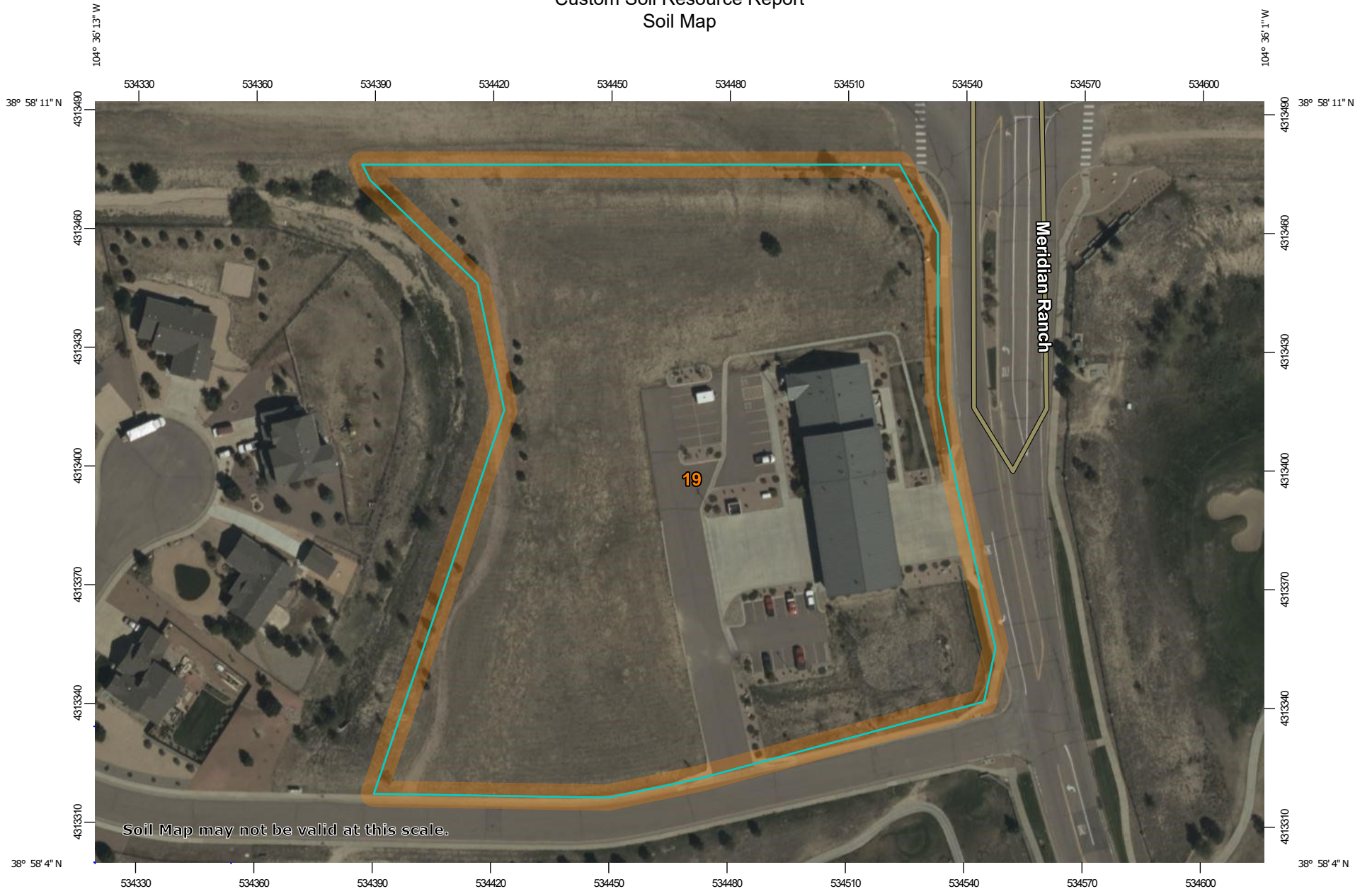

Map Scale: 1:1,360 if printed on A landscape (11" x 8.5") sheet.



Map projection: Web Mercator Corner coordinates: WGS84 Edge tics: UTM Zone 13N WGS84



MAP LEGEND

Area of Interest (AOI)

 Area of Interest (AOI)

Soils

 Soil Map Unit Polygons

 Soil Map Unit Lines

 Soil Map Unit Points

Special Point Features

 Blowout

 Borrow Pit

 Clay Spot

 Closed Depression

 Gravel Pit

 Gravelly Spot

 Landfill

 Lava Flow

 Marsh or swamp

 Mine or Quarry

 Miscellaneous Water

 Perennial Water

 Rock Outcrop

 Saline Spot

 Sandy Spot

 Severely Eroded Spot

 Sinkhole

 Slide or Slip

 Sodic Spot

 Spoil Area

 Stony Spot

 Very Stony Spot

 Wet Spot

 Other

 Special Line Features

Water Features

 Streams and Canals

Transportation

 Rails

 Interstate Highways

 US Routes

 Major Roads

 Local Roads

Background

 Aerial Photography

MAP INFORMATION

The soil surveys that comprise your AOI were mapped at 1:24,000.

Warning: Soil Map may not be valid at this scale.

Enlargement of maps beyond the scale of mapping can cause misunderstanding of the detail of mapping and accuracy of soil line placement. The maps do not show the small areas of contrasting soils that could have been shown at a more detailed scale.

Please rely on the bar scale on each map sheet for map measurements.

Source of Map: Natural Resources Conservation Service
 Web Soil Survey URL:
 Coordinate System: Web Mercator (EPSG:3857)

Maps from the Web Soil Survey are based on the Web Mercator projection, which preserves direction and shape but distorts distance and area. A projection that preserves area, such as the Albers equal-area conic projection, should be used if more accurate calculations of distance or area are required.

This product is generated from the USDA-NRCS certified data as of the version date(s) listed below.

Soil Survey Area: El Paso County Area, Colorado
 Survey Area Data: Version 19, Aug 31, 2021

Soil map units are labeled (as space allows) for map scales 1:50,000 or larger.

Date(s) aerial images were photographed: Sep 11, 2018—Oct 20, 2018

The orthophoto or other base map on which the soil lines were compiled and digitized probably differs from the background imagery displayed on these maps. As a result, some minor shifting of map unit boundaries may be evident.

Map Unit Legend

| Map Unit Symbol | Map Unit Name | Acres in AOI | Percent of AOI |
|------------------------------------|---|--------------|----------------|
| 19 | Columbine gravelly sandy loam, 0 to 3 percent slopes | 4.9 | 100.0% |
| Totals for Area of Interest | | 4.9 | 100.0% |

Map Unit Descriptions

The map units delineated on the detailed soil maps in a soil survey represent the soils or miscellaneous areas in the survey area. The map unit descriptions, along with the maps, can be used to determine the composition and properties of a unit.

A map unit delineation on a soil map represents an area dominated by one or more major kinds of soil or miscellaneous areas. A map unit is identified and named according to the taxonomic classification of the dominant soils. Within a taxonomic class there are precisely defined limits for the properties of the soils. On the landscape, however, the soils are natural phenomena, and they have the characteristic variability of all natural phenomena. Thus, the range of some observed properties may extend beyond the limits defined for a taxonomic class. Areas of soils of a single taxonomic class rarely, if ever, can be mapped without including areas of other taxonomic classes. Consequently, every map unit is made up of the soils or miscellaneous areas for which it is named and some minor components that belong to taxonomic classes other than those of the major soils.

Most minor soils have properties similar to those of the dominant soil or soils in the map unit, and thus they do not affect use and management. These are called noncontrasting, or similar, components. They may or may not be mentioned in a particular map unit description. Other minor components, however, have properties and behavioral characteristics divergent enough to affect use or to require different management. These are called contrasting, or dissimilar, components. They generally are in small areas and could not be mapped separately because of the scale used. Some small areas of strongly contrasting soils or miscellaneous areas are identified by a special symbol on the maps. If included in the database for a given area, the contrasting minor components are identified in the map unit descriptions along with some characteristics of each. A few areas of minor components may not have been observed, and consequently they are not mentioned in the descriptions, especially where the pattern was so complex that it was impractical to make enough observations to identify all the soils and miscellaneous areas on the landscape.

The presence of minor components in a map unit in no way diminishes the usefulness or accuracy of the data. The objective of mapping is not to delineate pure taxonomic classes but rather to separate the landscape into landforms or landform segments that have similar use and management requirements. The delineation of such segments on the map provides sufficient information for the development of resource plans. If intensive use of small areas is planned, however, onsite investigation is needed to define and locate the soils and miscellaneous areas.

Custom Soil Resource Report

An identifying symbol precedes the map unit name in the map unit descriptions. Each description includes general facts about the unit and gives important soil properties and qualities.

Soils that have profiles that are almost alike make up a *soil series*. Except for differences in texture of the surface layer, all the soils of a series have major horizons that are similar in composition, thickness, and arrangement.

Soils of one series can differ in texture of the surface layer, slope, stoniness, salinity, degree of erosion, and other characteristics that affect their use. On the basis of such differences, a soil series is divided into *soil phases*. Most of the areas shown on the detailed soil maps are phases of soil series. The name of a soil phase commonly indicates a feature that affects use or management. For example, Alpha silt loam, 0 to 2 percent slopes, is a phase of the Alpha series.

Some map units are made up of two or more major soils or miscellaneous areas. These map units are complexes, associations, or undifferentiated groups.

A *complex* consists of two or more soils or miscellaneous areas in such an intricate pattern or in such small areas that they cannot be shown separately on the maps. The pattern and proportion of the soils or miscellaneous areas are somewhat similar in all areas. Alpha-Beta complex, 0 to 6 percent slopes, is an example.

An *association* is made up of two or more geographically associated soils or miscellaneous areas that are shown as one unit on the maps. Because of present or anticipated uses of the map units in the survey area, it was not considered practical or necessary to map the soils or miscellaneous areas separately. The pattern and relative proportion of the soils or miscellaneous areas are somewhat similar. Alpha-Beta association, 0 to 2 percent slopes, is an example.

An *undifferentiated group* is made up of two or more soils or miscellaneous areas that could be mapped individually but are mapped as one unit because similar interpretations can be made for use and management. The pattern and proportion of the soils or miscellaneous areas in a mapped area are not uniform. An area can be made up of only one of the major soils or miscellaneous areas, or it can be made up of all of them. Alpha and Beta soils, 0 to 2 percent slopes, is an example.

Some surveys include *miscellaneous areas*. Such areas have little or no soil material and support little or no vegetation. Rock outcrop is an example.

El Paso County Area, Colorado

19—Columbine gravelly sandy loam, 0 to 3 percent slopes

Map Unit Setting

National map unit symbol: 367p
Elevation: 6,500 to 7,300 feet
Mean annual precipitation: 14 to 16 inches
Mean annual air temperature: 46 to 50 degrees F
Frost-free period: 125 to 145 days
Farmland classification: Not prime farmland

Map Unit Composition

Columbine and similar soils: 97 percent
Minor components: 3 percent
Estimates are based on observations, descriptions, and transects of the mapunit.

Description of Columbine

Setting

Landform: Flood plains, fan terraces, fans
Down-slope shape: Linear
Across-slope shape: Linear
Parent material: Alluvium

Typical profile

A - 0 to 14 inches: gravelly sandy loam
C - 14 to 60 inches: very gravelly loamy sand

Properties and qualities

Slope: 0 to 3 percent
Depth to restrictive feature: More than 80 inches
Drainage class: Well drained
Runoff class: Very low
Capacity of the most limiting layer to transmit water (Ksat): High to very high (5.95 to 19.98 in/hr)
Depth to water table: More than 80 inches
Frequency of flooding: None
Frequency of ponding: None
Available water supply, 0 to 60 inches: Very low (about 2.5 inches)

Interpretive groups

Land capability classification (irrigated): 4e
Land capability classification (nonirrigated): 6e
Hydrologic Soil Group: A
Ecological site: R049XY214CO - Gravelly Foothill
Hydric soil rating: No

Minor Components

Fluvaquentic haplaquolls

Percent of map unit: 1 percent
Landform: Swales
Hydric soil rating: Yes

Custom Soil Resource Report

Other soils

Percent of map unit: 1 percent

Hydric soil rating: No

Pleasant

Percent of map unit: 1 percent

Landform: Depressions

Hydric soil rating: Yes

APPENDIX C
GRADING & EROSION CONTROL PLAN

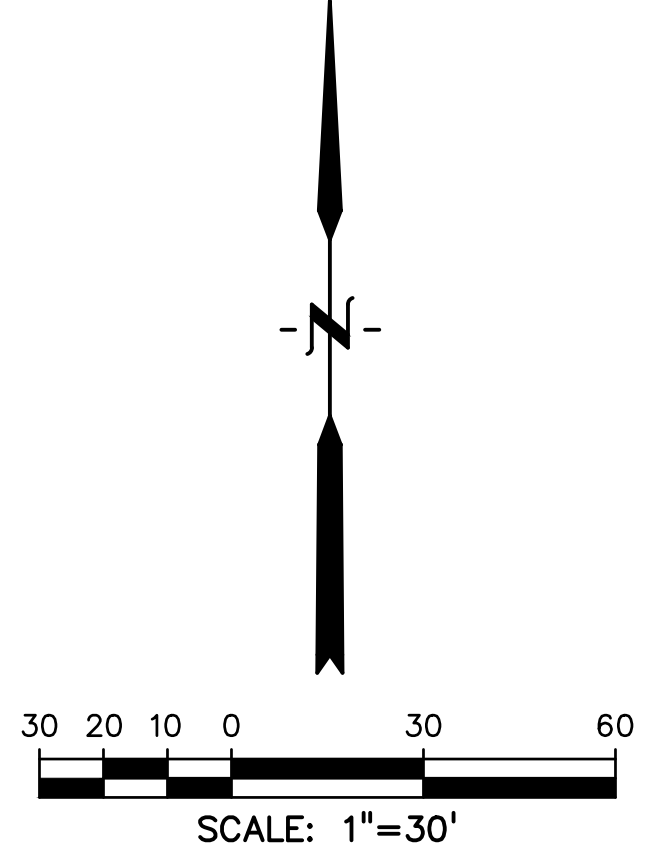
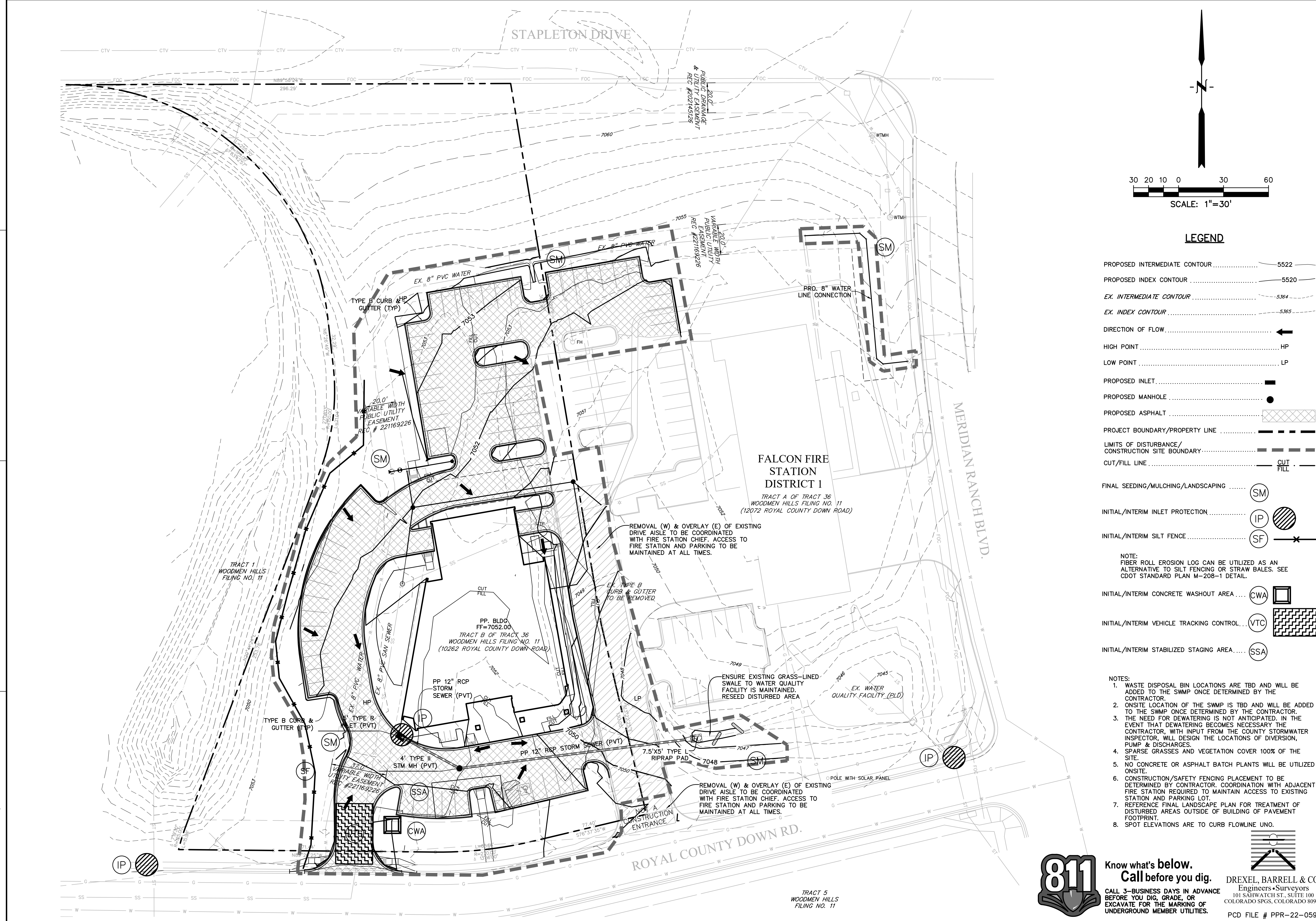

LEGEND

- PROPOSED INTERMEDIATE CONTOUR 5522
- PROPOSED INDEX CONTOUR 5520
- EX. INTERMEDIATE CONTOUR 5384
- EX. INDEX CONTOUR 5365
- DIRECTION OF FLOW
- HIGH POINT HP
- LOW POINT LP
- PROPOSED INLET
- PROPOSED MANHOLE
- PROPOSED ASPHALT
- PROJECT BOUNDARY/PROPERTY LINE
- LIMITS OF DISTURBANCE/CONSTRUCTION SITE BOUNDARY
- CUT/FILL LINE
- FINAL SEEDING/MULCHING/LANDSCAPING
- INITIAL/INTERIM INLET PROTECTION
- INITIAL/INTERIM SILT FENCE
- NOTE: FIBER ROLL EROSION LOG CAN BE UTILIZED AS AN ALTERNATIVE TO SILT FENCING OR STRAW BALES. SEE CDOT STANDARD PLAN M-208-1 DETAIL.
- INITIAL/INTERIM CONCRETE WASHOUT AREA
- INITIAL/INTERIM VEHICLE TRACKING CONTROL
- INITIAL/INTERIM STABILIZED STAGING AREA

- NOTES:**
- WASTE DISPOSAL BIN LOCATIONS ARE TBD AND WILL BE ADDED TO THE SWMP ONCE DETERMINED BY THE CONTRACTOR.
 - ONSITE LOCATION OF THE SWMP IS TBD AND WILL BE ADDED TO THE SWMP ONCE DETERMINED BY THE CONTRACTOR.
 - THE NEED FOR DEWATERING IS NOT ANTICIPATED. IN THE EVENT THAT DEWATERING BECOMES NECESSARY THE CONTRACTOR, WITH INPUT FROM THE COUNTY STORMWATER INSPECTOR, WILL DESIGN THE LOCATIONS OF DIVERSION, PUMP & DISCHARGES.
 - SPARSE GRASSES AND VEGETATION COVER 100% OF THE SITE.
 - NO CONCRETE OR ASPHALT BATCH PLANTS WILL BE UTILIZED ONSITE.
 - CONSTRUCTION/SAFETY FENCING PLACEMENT TO BE DETERMINED BY CONTRACTOR. COORDINATION WITH ADJACENT FIRE STATION REQUIRED TO MAINTAIN ACCESS TO EXISTING STATION AND PARKING LOT.
 - REFERENCE FINAL LANDSCAPE PLAN FOR TREATMENT OF DISTURBED AREAS OUTSIDE OF BUILDING OF PAVEMENT FOOTPRINT.
 - SPOT ELEVATIONS ARE TO CURB FLOWLINE UNO.



D2C ARCHITECTS, INC
DENVER, COLORADO
COPYRIGHT © 2023

THESE DRAWINGS AND PLANS ARE
COPYRIGHTED AND ARE NOT TO BE USED
OR REPRODUCED WHOLLY OR IN PART
WITHOUT THE WRITTEN PERMISSION OF
D2C ARCHITECTS, INC.

| DATE | APPROVALS | DESCRIPTION | MARKS |
|------|-----------|-------------|-------|
| | | | |
| | | | |
| | | | |
| | | | |
| | | | |
| | | | |
| | | | |
| | | | |
| | | | |

| | | | |
|---------------------------------------|---|-------------------|-----------------------|
| ISSUE DATE: OCTOBER 6, 2023 | CONSULTANT'S PROJECT # 21659-00 CSDV | SOLICITATION NO.: | CONTRACT NO.: |
| DESIGN BY: KGV | D2C PROJECT NUMBER | DRAWN BY: ARAW | CHECKED BY: CHUBBY |
| DATE: OCT 06 2023 | FILE NUMBER: | PLAT DATE: | FILE NAME: |
| DATE: | FILE NUMBER: | PLAT SCALE: | FILE NAME: |
| DATE: | FILE NUMBER: | PLAT SCALE: | FILE NAME: |
| DATE: | FILE NUMBER: | PLAT SCALE: | FILE NAME: |
| DATE: | FILE NUMBER: | PLAT SCALE: | FILE NAME: |
| DATE: | FILE NUMBER: | PLAT SCALE: | FILE NAME: |
| DATE: | FILE NUMBER: | PLAT SCALE: | FILE NAME: |
| DATE: | FILE NUMBER: | PLAT SCALE: | FILE NAME: |
| DATE: | FILE NUMBER: | PLAT SCALE: | FILE NAME: |

GRADING & EROSION CONTROL PLAN

NOT FOR CONSTRUCTION

EI Paso County Sheriff's Department
FALCON SHERIFF SUBSTATION
10262 Royal County Down Rd. Falcon, Colorado 80831

INTERIM/FINAL GRADING & EROSION CONTROL PLAN



Know what's below. Call before you dig.

CALL 3-BUSINESS DAYS IN ADVANCE BEFORE YOU DIG, GRADE, OR EXCAVATE FOR THE MARKING OF UNDERGROUND MEMBER UTILITIES.

DREXEL, BARRELL & CO.
Engineers • Surveyors
101 SAHATCH ST., SUITE 100
COLORADO SPGS, COLORADO 80903
PCD FILE # PPR-22-059

SHEET IDENTIFICATION EC2

Stabilized Staging Area (SSA) SM-6

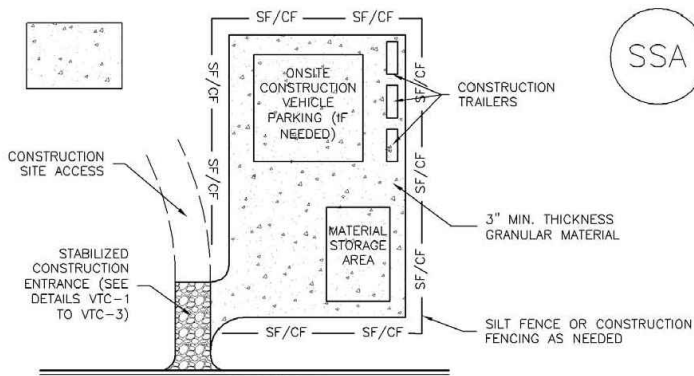

SSA-1. STABILIZED STAGING AREA

- STABILIZED STAGING AREA INSTALLATION NOTES
1. SEE PLAN VIEW FOR LOCATION AND LENGTH OF STAGING AREA WITH APPROVAL FROM THE LOCAL JURISDICTION.

- STABILIZED STAGING AREA MAINTENANCE NOTES
1. INSPECT BMPs EACH WORKDAY, AND MAINTAIN THEM IN EFFECTIVE OPERATING CONDITION.

November 2010 Urban Drainage and Flood Control District Urban Storm Drainage Criteria Manual Volume 3 SSA-3

Silt Fence (SF) SC-1

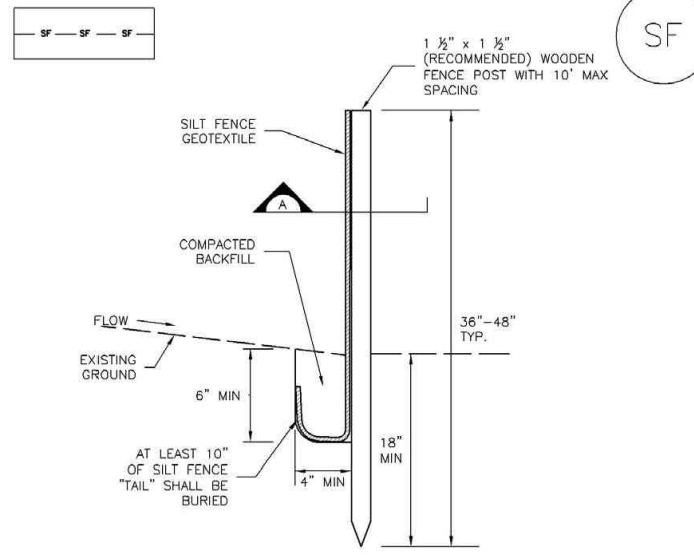

SILT FENCE

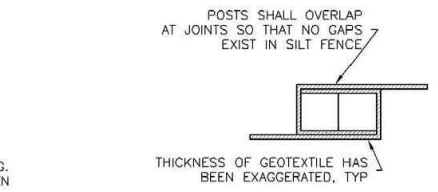

SECTION A

SF-1. SILT FENCE

November 2010 Urban Drainage and Flood Control District Urban Storm Drainage Criteria Manual Volume 3 SF-3

Stabilized Staging Area (SSA) SM-6

- STABILIZED STAGING AREA MAINTENANCE NOTES
5. STABILIZED STAGING AREA SHALL BE ENLARGED IF NECESSARY TO CONTAIN PARKING, STORAGE, AND UNLOADING/LOADING OPERATIONS.

SSA-4 Urban Drainage and Flood Control District Urban Storm Drainage Criteria Manual Volume 3 November 2010

Silt Fence (SF) SC-1

- SILT FENCE INSTALLATION NOTES
1. SILT FENCE MUST BE PLACED AWAY FROM THE TOE OF THE SLOPE TO ALLOW FOR WATER PONDING.

SF-4 Urban Drainage and Flood Control District Urban Storm Drainage Criteria Manual Volume 3 November 2010

Concrete Washout Area (CWA) MM-1

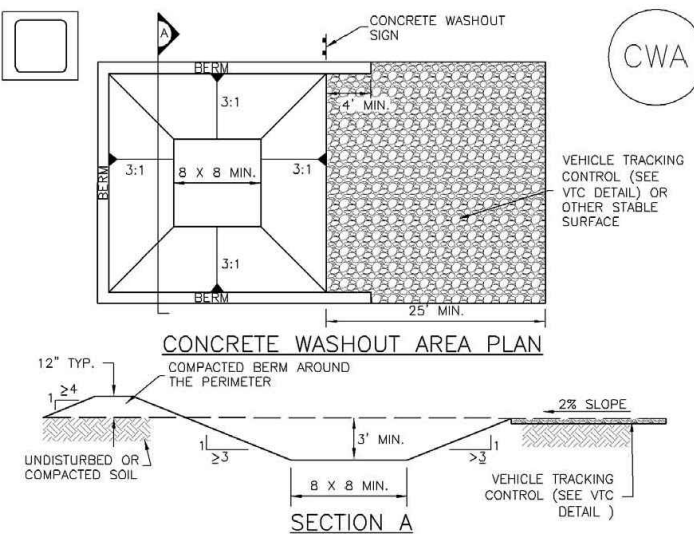

CWA-1. CONCRETE WASHOUT AREA

November 2010 Urban Drainage and Flood Control District Urban Storm Drainage Criteria Manual Volume 3 CWA-3

Sediment Control Log (SCL) SC-2

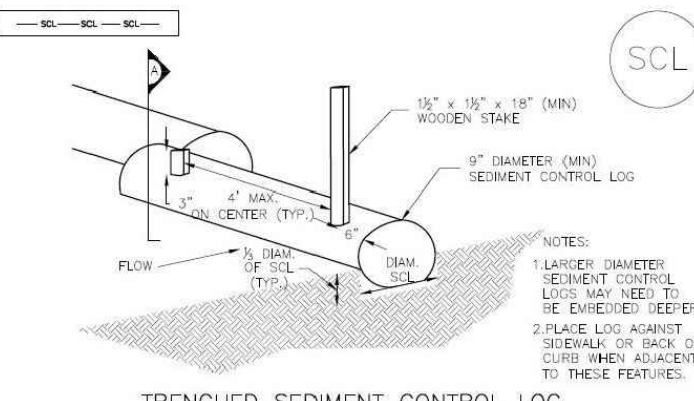

TRENCHED SEDIMENT CONTROL LOG

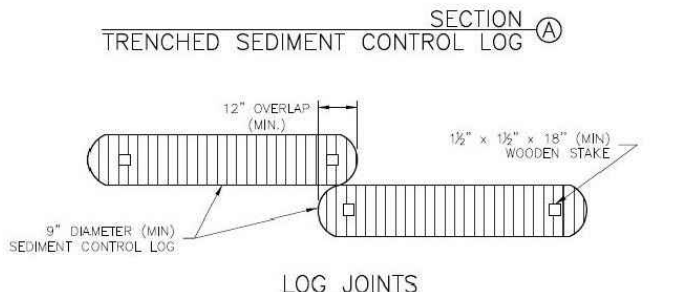

LOG JOINTS

SCL-1. TRENCHED SEDIMENT CONTROL LOG

November 2015 Urban Drainage and Flood Control District Urban Storm Drainage Criteria Manual Volume 3 SCL-3

Sediment Control Log (SCL) SC-2

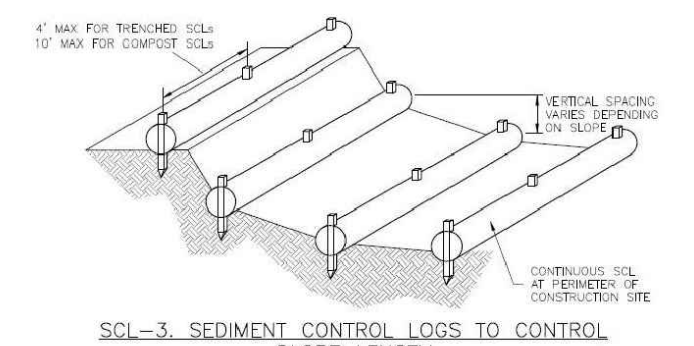

SCL-3. SEDIMENT CONTROL LOGS TO CONTROL SLOPE LENGTH

November 2015 Urban Drainage and Flood Control District Urban Storm Drainage Criteria Manual Volume 3 SCL-5

Concrete Washout Area (CWA) MM-1

- CWA MAINTENANCE NOTES
1. INSPECT BMPs EACH WORKDAY, AND MAINTAIN THEM IN EFFECTIVE OPERATING CONDITION.

CWA-4 Urban Drainage and Flood Control District Urban Storm Drainage Criteria Manual Volume 3 November 2010

Sediment Control Log (SCL) SC-2

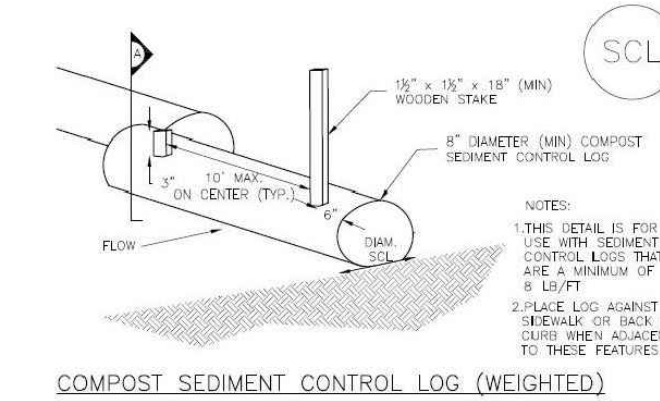

COMPOST SEDIMENT CONTROL LOG (WEIGHTED)

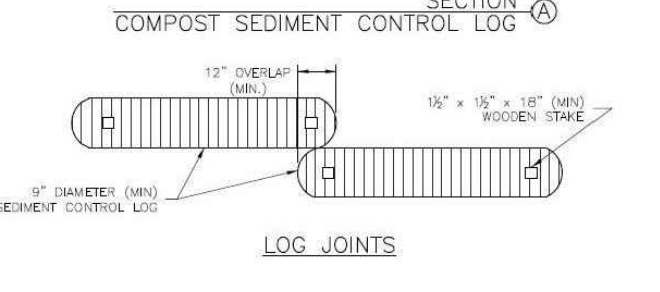

LOG JOINTS

SCL-2. COMPOST SEDIMENT CONTROL LOG (WEIGHTED)

November 2015 Urban Drainage and Flood Control District Urban Storm Drainage Criteria Manual Volume 3 SCL-4

Sediment Control Log (SCL) SC-2

- SEDIMENT CONTROL LOG INSTALLATION NOTES
1. SEE PLAN VIEW FOR LOCATION AND LENGTH OF SEDIMENT CONTROL LOGS.

November 2015 Urban Drainage and Flood Control District Urban Storm Drainage Criteria Manual Volume 3 SCL-6

TEMPORARY SEEDING NOTES

- 1. SOIL IS TO BE CONDITIONED FOR PLANT GROWTH BY APPLYING TOPSOIL, FERTILIZER OR LIME.
2. SOIL IS TO BE TILLED IMMEDIATELY PRIOR TO APPLYING SEEDS. COMPACT SOILS ESPECIALLY NEED TO BE LOOSENED.

MULCHING NOTES

- 1. MATERIAL USED FOR MULCH CAN BE CERTIFIED CLEAN, WEED-AND SEED-FREE LONG STEMMED FIELD OR MARSH HAY, OR STRAW OF OATS, BARLEY, WHEAT, RYE, OR TRITICALE CERTIFIED BY THE COLORADO DEPARTMENT OF AGRICULTURE WEED FREE FORAGE CERTIFICATION PROGRAM.

INSTALLATION REQUIREMENTS

- 1. REGULAR INSPECTIONS ARE TO BE MADE OF ALL MULCHED AREAS.

SEEDING PLAN

NATIVE SEEDING MIX

SOIL PREPARATION, FERTILIZER, SEEDING, MULCHING AND MULCH TACKIFIER WILL BE REQUIRED FOR DISTURBED AREAS EXCLUDING THE RIGHT-OF-WAYS.

THE FOLLOWING TYPES AND RATES SHALL BE USED:

Table with columns: COMMON NAME, SCIENTIFIC NAME, LBS PLS/ACRE. Lists various grasses like Sand Bluestem and Western Wheatgrass.

Table with columns: FERTILIZER, RATE PER ACRE. Lists Nitrogen and Phosphorus (P205) rates.

SEEDING APPLICATION: DRILL SEED 0.25"-0.5" INTO TOPSOIL. AREA NOT ACCESSIBLE TO A DRILL SEEDER AND SLOPES STEEPER THAN 2:1 SHALL BE HAND BROADCAST AT DOUBLE THE ABOVE SEED RATE...

MULCHING APPLICATION: 1 1/2 TONS CERTIFIED WEED FREE NATIVE HAY PER ACRE MECHANICALLY CRIMED IN TOPSOIL IN COMBINATION WITH AN ORGANIC MULCH TACKIFIER.



Know what's below. Call before you dig. CALL 2-BUSINESS DAYS IN ADVANCE BEFORE YOU DIG, GRADE, OR EXCAVATE FOR THE MARKING OF UNDERGROUND MEMBER UTILITIES.

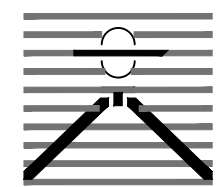

DREXEL, BARRELL & CO. Engineers-Surveyors 101 SAWATCH ST., SUITE 100 COLORADO SPGS, COLORADO 80903 PCD FILE # PPR-22-059



D2C ARCHITECTS, INC DENVER, COLORADO COPYRIGHT © 2011 THESE DRAWINGS AND PLANS ARE COPYRIGHTED AND ARE NOT TO BE USED OR REPRODUCED WHOLLY OR IN PART WITHOUT THE WRITTEN PERMISSION OF D2C ARCHITECTS, INC.

Table with columns: MARK, DATE, APPR. for revision tracking.

Table with columns: DESIGN BY, LOG PROJECT NUMBER, DESIGN BY, DATE, DRAWN BY, DATE, CHECKED BY, DATE, PLANT DATE, PLOT SCALE, FILE NAME.

GRADING & EROSION CONTROL PLAN

NOT FOR CONSTRUCTION

EI Paso County Sheriff's Department FALCON SHERIFF SUBSTATION 10262 Royal County Down Rd. Falcon, Colorado 80831 EROSION CONTROL DETAILS

SHEET IDENTIFICATION DT2

APPENDIX D
INSPECTION TEMPLATE

CONSTRUCTION STORMWATER SITE INSPECTION REPORT

| | | | | | | | |
|--|--------------------------|--------------------|--|-----|----|--------------------------|--------------------------|
| Facility Name | | Permittee | | | | | |
| Date of Inspection | | Weather Conditions | | | | | |
| Permit Certification # | | Disturbed Acreage | | | | | |
| Phase of Construction | | Inspector Title | | | | | |
| Inspector Name | | | | | | | |
| Is the above inspector a qualified stormwater manager? (permittee is responsible for ensuring that the inspector is a qualified stormwater manager) | | | <table border="1" style="width: 100%; border-collapse: collapse;"> <tr> <td style="width: 50%; text-align: center;">YES</td> <td style="width: 50%; text-align: center;">NO</td> </tr> <tr> <td style="text-align: center;"><input type="checkbox"/></td> <td style="text-align: center;"><input type="checkbox"/></td> </tr> </table> | YES | NO | <input type="checkbox"/> | <input type="checkbox"/> |
| YES | NO | | | | | | |
| <input type="checkbox"/> | <input type="checkbox"/> | | | | | | |

| INSPECTION FREQUENCY | | | | | |
|---|--|-----|----|--------------------------|--------------------------|
| Check the box that describes the minimum inspection frequency utilized when conducting each inspection | | | | | |
| At least one inspection every 7 calendar days | <input type="checkbox"/> | | | | |
| At least one inspection every 14 calendar days, with post-storm event inspections conducted within 24 hours after the end of any precipitation or snowmelt event that causes surface erosions | <input type="checkbox"/> | | | | |
| <ul style="list-style-type: none"> • This is this a post-storm event inspection. Event Date: _____ | <input type="checkbox"/> | | | | |
| Reduced inspection frequency - Include site conditions that warrant reduced inspection frequency | <input type="checkbox"/> | | | | |
| <ul style="list-style-type: none"> • Post-storm inspections at temporarily idle sites | <input type="checkbox"/> | | | | |
| <ul style="list-style-type: none"> • Inspections at completed sites/area | <input type="checkbox"/> | | | | |
| <ul style="list-style-type: none"> • Winter conditions exclusion | <input type="checkbox"/> | | | | |
| Have there been any deviations from the minimum inspection schedule? If yes, describe below. | <table border="1" style="width: 100%; border-collapse: collapse;"> <tr> <td style="width: 50%; text-align: center;">YES</td> <td style="width: 50%; text-align: center;">NO</td> </tr> <tr> <td style="text-align: center;"><input type="checkbox"/></td> <td style="text-align: center;"><input type="checkbox"/></td> </tr> </table> | YES | NO | <input type="checkbox"/> | <input type="checkbox"/> |
| YES | NO | | | | |
| <input type="checkbox"/> | <input type="checkbox"/> | | | | |
| | | | | | |

| INSPECTION REQUIREMENTS* |
|---|
| i. Visually verify all implemented control measures are in effective operational condition and are working as designed in the specifications |
| ii. Determine if there are new potential sources of pollutants |
| iii. Assess the adequacy of control measures at the site to identify areas requiring new or modified control measures to minimize pollutant discharges |
| iv. Identify all areas of non-compliance with the permit requirements, and if necessary, implement corrective action |
| *Use the attached Control Measures Requiring Routine Maintenance and Inadequate Control Measures Requiring Corrective Action forms to document results of this assessment that trigger either maintenance or corrective actions |

| AREAS TO BE INSPECTED | | | |
|---|--------------------------|--------------------------|--|
| Is there evidence of, or the potential for, pollutants leaving the construction site boundaries, entering the stormwater drainage system or discharging to state waters at the following locations? | | | |
| | NO | YES | If "YES" describe discharge or potential for discharge below. Document related maintenance, inadequate control measures and corrective actions Inadequate Control Measures Requiring Corrective Action form |
| Construction site perimeter | <input type="checkbox"/> | <input type="checkbox"/> | |
| All disturbed areas | <input type="checkbox"/> | <input type="checkbox"/> | |
| Designated haul routes | <input type="checkbox"/> | <input type="checkbox"/> | |
| Material and waste storage areas exposed to precipitation | <input type="checkbox"/> | <input type="checkbox"/> | |
| Locations where stormwater has the potential to discharge offsite | <input type="checkbox"/> | <input type="checkbox"/> | |
| Locations where vehicles exit the site | <input type="checkbox"/> | <input type="checkbox"/> | |
| Other: _____ | <input type="checkbox"/> | <input type="checkbox"/> | |

REPORTING REQUIREMENTS

The permittee shall report the following circumstances orally within twenty-four (24) hours from the time the permittee becomes aware of the circumstances, and shall mail to the division a written report containing the information requested within five (5) working days after becoming aware of the following circumstances. The division may waive the written report required if the oral report has been received within 24 hours.

| | | |
|---|--|--|
| All Noncompliance Requiring 24-Hour Notification per Part II.L.6 of the Permit | | |
| a. Endangerment to Health or the Environment Circumstances leading to any noncompliance which may endanger health or the environment regardless of the cause of the incident (See Part II.L.6.a of the Permit) <i>This category would primarily result from the discharge of pollutants in violation of the permit</i> | | |
| b. Numeric Effluent Limit Violations <ul style="list-style-type: none"> o Circumstances leading to any unanticipated bypass which exceeds any effluent limitations (See Part II.L.6.b of the Permit) o Circumstances leading to any upset which causes an exceedance of any effluent limitation (See Part II.L.6.c of the Permit) o Daily maximum violations (See Part II.L.6.d of the Permit) <i>Numeric effluent limits are very uncommon in certifications under the COR400000 general permit. This category of noncompliance only applies if numeric effluent limits are included in a permit certification.</i> | | |

| | | | |
|---|--------------------------|--------------------------|-------------------------|
| Has there been an incident of noncompliance requiring 24-hour notification? | NO | YES | |
| | <input type="checkbox"/> | <input type="checkbox"/> | If "YES" document below |

| Date and Time of Incident | Location | Description of Noncompliance | Description of Corrective Action | Date and Time of 24 Hour Oral Notification | Date of 5 Day Written Notification * |
|---------------------------|----------|------------------------------|----------------------------------|--|--------------------------------------|
| | | | | | |
| | | | | | |

*Attach copy of 5 day written notification to report. Indicate if written notification was waived, including the name of the division personnel who granted waiver.

After adequate corrective action(s) and maintenance have been taken, or where a report does not identify any incidents requiring corrective action or maintenance, the individual(s) designated as the Qualified Stormwater Manager, shall sign and certify the below statement:

"I verify that, to the best of my knowledge and belief, all corrective action and maintenance items identified during the inspection are complete, and the site is currently in compliance with the permit."

Name of Qualified Stormwater Manager

Title of Qualified Stormwater Manager

Signature of Qualified Stormwater Manager

Date

Notes/Comments