



LSC TRANSPORTATION CONSULTANTS, INC.
2504 East Pikes Peak Avenue, Suite 304
Colorado Springs, CO 80909
(719) 633-2868
FAX (719) 633-5430
E-mail: lsc@lsctrans.com
Website: <http://www.lsctrans.com>

ACCEPTED for FILE
Engineering Review
08/16/2022 3:47:21 PM
dsdnijkamp
EPC Planning & Community
Development Department

The Ridge at Lorson Ranch
Filing Nos. 1, 2, and 3
Transportation Memorandum
PCD File No. SF 22-004
(LSC #S214082)
July 20, 2022

Traffic Engineer's Statement

This traffic report and supporting information were prepared under my responsible charge and they comport with the standard of care. So far as is consistent with the standard of care, said report was prepared in general conformance with the criteria established by the County for traffic reports.



Developer's Statement

I, the Developer, have read and will comply with all commitments made on my behalf within this report.



7/25/22
Date



LSC TRANSPORTATION CONSULTANTS, INC.
2504 East Pikes Peak Avenue, Suite 304
Colorado Springs, CO 80909
(719) 633-2868
FAX (719) 633-5430
E-mail: lsc@lsctrans.com
Website: <http://www.lsctrans.com>

July 20, 2022

Mr. Jeff Mark
The Landhuis Company
212 North Wahsatch Avenue, Suite 301
Colorado Springs, CO 80903

RE: The Ridge at Lorson Ranch
Filing Nos. 1-3 Final Plats
El Paso County, Colorado
Transportation Memorandum
PCD File No. SF 22-004
LSC #S214082

Dear Mr. Mark:

LSC Transportation Consultants, Inc. has prepared this transportation memorandum to accompany the final plat submittals for the Ridge at Lorson Ranch Filing Nos. 1 through 3. The site is located north of the future Lorson Boulevard and East of Lamprey Drive in El Paso County, Colorado.

LSC prepared a full traffic impact study (TIS) for this development dated November 5, 2021 (PUDSP216). The lot and street plan has not changed since completion of that report. This memorandum presents an updated analysis of roadway improvements by filing and an updated analysis of the required fees for each filing to the El Paso County Road Improvement Fee Program.

SITE DEVELOPMENT AND LAND USE

The Ridge at Lorson Ranch is planned to include 994 lots for single-family homes. Although the lot and street plan has not changed since the November 2021 PUD TIS, the development is now planned to be divided into three filings with 535, 277, and 182 lots respectively. Figure 1 shows the location of the proposed filings.

TRIP GENERATION

The Ridge at Lorson Ranch Filing Nos. 1-3 site-generated vehicle trips have been estimated using the nationally published trip-generation rates from *Trip Generation, 11th Edition, 2021* by the Institute of Transportation Engineers (ITE). Table 1 shows the trip-generation estimate. Table 1

also shows estimates of the traffic expected to be generated for the same area in the November 2021 PUD TIS. The trip-generation estimate shown in that report was based on the trip-generation rates for Single Family Detached Housing from the **10th Edition** of *Trip Generation*, which are slightly higher than the rates shown in the current 11th Edition.

The Ridge at Lorson Ranch Filing Nos. 1-3 is expected to generate 9,373 vehicle trips on the average weekday, with about half entering and half exiting the site during a 24-hour period. This is about 10 **fewer** vehicle trips per day than was assumed in the November 2021 PUD TIS. During the morning peak hour, which generally occurs for one hour between 6:30 and 8:30 a.m., about 181 vehicles would enter and 515 vehicles would exit the site. Due to the change in trip-generation rates, this is three **fewer** entering trips and 37 **fewer** exiting trips than was assumed in the November 2021 PUD TIS. During the afternoon peak hour, which generally occurs for one hour between 4:15 and 6:15 p.m., about 589 vehicles would enter and 346 vehicles would exit the site. Due to the change in trip-generation rates, this is 31 **fewer** entering tips and 18 **fewer** exiting trips than was assumed in the November 2021 PUD TIS.

FUTURE TRAFFIC VOLUMES AND LEVELS OF SERVICE

Please refer to the November PUD TIS for future traffic volumes and level of service.

TRAFFIC-SIGNAL WARRANTS

The intersection of Marksheffel Road/Lorson Boulevard was analyzed to determine if a traffic-signal warrant, based on either vehicular volume or crash history, is currently met. The vehicular-volume traffic-signal warrant analysis is based on manual turning-movement counts conducted by LSC in March 2022. The count-data sheets are attached for reference.

Warrant 1, Eight-Hour Vehicular Volume

The combination of major-street approach volumes (includes the sum of the northbound and southbound approach volumes on Marksheffel Road) and minor-street volumes (eastbound left-turn volume only on Lorson Boulevard) at the subject intersection were analyzed to determine if the combination currently exceeds or would exceed the threshold criteria for Eight-Hour Vehicular-Volume Traffic-Signal Warrants in the 2009 *Manual on Uniform Traffic Control Devices (MUTCD)*. Table 2 shows the warrant evaluation. The minor approach was analyzed as a single-lane approach, only considering the eastbound left-turn volume, as there is an existing exclusive right-turn lane.

All eight of the hours analyzed currently meet the thresholds for an Eight-Hour Vehicular-Volume Warrant based on Condition B – Interruption of Continuous Traffic. **This warrant is currently met.**

Warrant 2, Four-Hour Vehicular Volume

The combination of major-street approach volumes (includes the sum of northbound and southbound approach volumes on Marksheffel Road) and minor-street volumes (eastbound left-turn volume only on Lorson Boulevard) at the subject intersection were analyzed to determine if the combination currently exceeds or would exceed the threshold criteria for a Four-Hour Vehicular-Volume Traffic-Signal Warrant in the 2009 *MUTCD*. Table 2 shows the warrant evaluation.

All eight of the hours analyzed currently meet the thresholds for a Four-Hour Vehicular-Volume Warrant. **This warrant is currently met.**

Warrant 3, Peak Hour

Per the *MUTCD*, *“This signal warrant shall be applied only in unusual cases, such as office complexes, manufacturing plants, industrial complexes, or high-occupancy vehicle facilities that attract or discharge large numbers of vehicles over a short time.”* Based on this standard, a peak-hour traffic-signal warrant should not be applied to the intersection of Marksheffel/Lorson.

Warrant 4, Pedestrian Volume

Per the *MUTCD*, *“The Pedestrian Volume signal warrant is intended for application where the traffic volume on a major street is so heavy that pedestrians experience excessive delay in crossing the major street.”*

The lower-threshold pedestrian volume for a major street with a posted speed limit of greater than 35 miles per hour (mph) is 75 pedestrians per hour for a Four-Hour Volume Warrant and 93 pedestrians per hour for a Peak-Hour Pedestrian-Volume Warrant. The pedestrian volumes at the intersection of Lorson/Marksheffel are anticipated to be well below these thresholds.

Warrant 5, School Crossing

Per the *MUTCD*, *“The School Crossing signal warrant is intended for application where the fact that schoolchildren cross the major street is the principal reason to consider installing a traffic control signal.”*

No school children are anticipated to cross Marksheffel at Lorson.

Warrant 6, Coordinated Signal System

Per the *MUTCD*, *“Progressive movement in a coordinated signal system sometimes necessitates installing traffic control signals at intersections where they would not otherwise be needed in order to maintain proper platooning of vehicles.”*

It is our understanding that the existing signal at the adjacent intersection of Fontaine/Marksheffel is not part of a coordinated system. Even if this signal is placed in coordination with the construction of a future planned signal at Mesa Ridge/Marksheffel it is unlikely that a signal would be required at Lorson to maintain proper platooning of vehicles.

Warrant 7 Analysis (Crash Experience)

The following is from the MUTCD:

Support:

01 The Crash Experience signal warrant conditions are intended for application where the severity and frequency of crashes are the principal reasons to consider installing a traffic control signal.

Standard:

02 The need for a traffic control signal shall be considered if an engineering study finds that all of the following criteria are met:

A. Adequate trial of alternatives with satisfactory observance and enforcement has failed to reduce the crash frequency; and

B. Five or more reported crashes, of types susceptible to correction by a traffic control signal, have occurred within a 12-month period, each crash involving personal injury or property damage apparently exceeding the applicable requirements for a reportable crash; and

C. For each of any 8 hours of an average day, the vehicles per hour (vph) given in both of the 80 percent columns of Condition A in Table 4C-1 (see Section 4C.02), or the vph in both of the 80 percent columns of Condition B in Table 4C-1 exists on the major-street and the higher-volume minor-street approach, respectively, to the intersection, or the volume of pedestrian traffic is not less than 80 percent of the requirements specified in the Pedestrian Volume warrant. These major-street and minor-street volumes shall be for the same 8 hours. On the minor street, the higher volume shall not be required to be on the same approach during each of the 8 hours.

The Colorado State Patrol provided LSC with vehicle-crash data for the intersection of Marksheffel/Lorson from July 2019 through February 2022. There were eight reported crashes at this intersection during this period. Of those crashes, seven of them occurred during a 12-month period between February 2021 and January 2022. Five of the seven crashes during this 12-month period involved motorists on Lorson Boulevard (the stop-sign-controlled approach) failing to yield right-of-way to the major-street traffic. A copy of these data is attached for reference.

Based on the crash-history-data criteria discussed above, criteria B has been met and, based on the volume data shown in Table 2, criteria C has been met. However, in order for the overall warrant to be met, the County may first require a trial of alternatives and/or enforcement per criteria A.

Warrant 8, Roadway Network

Per the *MUTCD*, “Installing a traffic control signal at some intersections might be justified to encourage concentration and organization of traffic flow on a roadway network.”

This situation is not applicable to the intersection of Marksheffel/Lorson.

Warrant 9, Intersection Near a Grade Crossing

There are no existing grade crossings in the vicinity of the intersection of Marksheffel/Lorson.

Overall Analysis

As Four-Hour and Eight-Hour Vehicular-Volume Traffic-Signal Warrants are currently met, LSC recommends that plans to convert this intersection to signal control be prepared.

TRAFFIC SIGNAL ESCROW PERCENTAGES/AMOUNTS

Fontaine/Old Glory

As shown in *The Hills at Lorson Ranch Traffic Impact Analysis* (TIA), the intersection of Fontaine/Old Glory is anticipated to meet the thresholds for an All-Way, Stop-Sign-Control Warrant, Eight-Hour Vehicular-Volume Traffic-Signal Warrant, and Four-Hour Vehicular-Volume Traffic-Signal Warrant, based on the projected short-term traffic volumes. As the level of service analysis indicates that this intersection could operate at a satisfactory level of service in the short term with all-way, stop-sign control, LSC recommended in that report that this improvement be completed with The Hills at Lorson Ranch Final Plat and that an escrow account be set up to collect funds to convert this intersection to signal control in the future.

Table 3 shows the projected 2040 total traffic volumes on the minor approaches at the intersection of Fontaine Boulevard/Old Glory. The minor-approach volumes were assumed to include the northbound and southbound left-turn and through movements only. The right-turn volumes were excluded from the analysis as there are existing dedicated right-turn lanes on both approaches. As shown in Table 3, the Ridge at Lorson Ranch development is projected to contribute about 5.1 percent of the traffic due to future development. Assuming a total signal cost of \$300,000, a fair share contribution towards a future signal at this intersection would be \$15,190. Based on an equal contribution per lot for all lots within The Ridge at Lorson Ranch, Filing No. 1 would be responsible for \$8,176, Filing No. 2 would be responsible for \$4,233, and Filing No. 3 would be responsible for \$2,781.

Lorson/Marksheffel

Previous traffic impact studies completed by LSC for other filings within the Lorson Ranch development included traffic-signal warrant analysis and traffic-signal escrow for a future traffic signal at the intersection of Lorson Boulevard and Marksheffel Road. The most current report that included this information was the *Creekside South at Lorson Ranch Transportation Memorandum* dated March 9, 2020. Table 2 of the memorandum showed that escrow for this improvement had been met; however, the analysis was based on a signal cost of \$300,000 and the current estimated cost for this traffic signal is \$590,000. Table 4 shows an updated traffic-signal escrow analysis which assigns responsibility for the additional \$290,000 above the previous estimate based on the number of proposed dwelling units for subdivisions within Lorson Ranch that are currently under review including Creekside at Lorson Ranch Filing No. 2, The Hills at Lorson Ranch, and the Ridge at Lorson Ranch Filings Nos. 1 through 3. As shown in Table 4, the currently-proposed Ridge at Lorson Ranch filings would be responsible for the following amounts:

- Filing 1: \$102,477
- Filing 2: \$53,058
- Filing 3: \$34,861

Fontaine/Carriage Meadows

The Ridge at Lorson Ranch is not projected to add to the total traffic volumes on the minor approaches at the intersection of Fontaine/Carriage Meadows. No contribution to the escrow amounts towards a future signal at that intersection should be required for this development.

TRAFFIC IMPACTS AND RECOMMENDED IMPROVEMENTS

Please refer to the *Ridge at Lorson Ranch Full Traffic Impact Analysis (TIA)* dated October 8, 2021 (PUDSP216) for the short-term and 2040-total traffic volumes and level of service analysis. All recommended auxiliary turn lanes and roadway classifications from that report are still valid, but note, in response to a staff comment, notation has been added below and in the improvements table regarding northbound right-turn acceleration lanes on Marksheffel at Fontaine (and Lorson Boulevard) in the short term and long term.

The October 2021 full TIA included a table which presented improvements in the vicinity of the site. A copy of this table, with additional notes by LSC identifying which improvements will be required by each filing, has been attached.

Item 9 of the improvements table from the October 2021 full TIA identified the trigger for the addition of a second southbound left turn as when the southbound left-turn volume exceeds 505 vehicles per hour (vph). The current southbound left-turn volume (late May 2022) is 309 vph. As shown in Table 3, the projected afternoon peak-hour volume for this movement is projected to be 480 vehicles following buildout of the Ridge at Lorson Ranch Filing No. 1 and 523 vehicles following buildout of Filing No. 2. If all of the Ridge at Lorson Ranch is built prior to this improvement, the southbound left-

turn movement is projected to operate at LOS E and have a v/c ratio of 1.05. Per the attached development agreement, El Paso County would be responsible for constructing this lane.

Regarding the westbound-to-northbound right-turn movement at the intersection of Fontaine Boulevard/Marksheffel Road, and the potential need for a northbound right-turn acceleration lane on Marksheffel Road north of Fontaine, staff comments dated May 3, 2022 identified the need to reanalyze this turning movement with respect to the potential need for an acceleration lane.

- LSC conducted manual turning-movement counts at the intersection of Marksheffel/Fontaine in June 2021. That count indicated 254 westbound right-turning vehicles during the morning peak hour. This intersection was recounted in May of 2022 and the number of westbound right-turning vehicles during the morning peak hour had increased from 254 to 324 vehicles per hour in the AM peak hour.
- In the *Ridge at Lorson Ranch Full Traffic Impact Analysis* dated October 8, 2021 (PUDSP216), LSC did not assume a northbound right-turn acceleration lane in the short-term analysis and the LOS for this movement is LOS B in the AM and LOS A in the PM.
- For short-term analysis for Lorson Ranch and other area projects, LSC has indicated the following with respect to right-turn acceleration lanes: Although Marksheffel Road is classified as an Expressway, it was (from the two-lane, unimproved roadway cross section to cross-section) comparable to a Rural Minor Arterial cross section, instead of an Expressway cross section. Based on a Rural Minor Arterial classification, right-turn acceleration lanes are not typically required per the El Paso County *Engineering Criteria Manual* criteria.
- The crash data did not indicate a safety problem with the existing westbound right-turn movement; if necessary, enhanced signage and/or striping could be added to emphasize that this movement is not a “free right,” rather a yield-controlled right turn.
- The improvements table called for separate left-turn signal phasing at Marksheffel/Fontaine. With a separate southbound left-turn phase, there will be additional opportunity for westbound right turns to enter northbound Marksheffel without the need to accelerate and merge. Since Fontaine is a significant cross street with Marksheffel, right turns can also occur with minimal conflict during the east/west signal green phase.
- The westbound right-turn current condition is a separate right-turn lane, painted right-turn island, and yield-sign traffic control.
- Should El Paso County deem this lane necessary, per the attached development agreement, El Paso County would be responsible for constructing this lane. If deemed necessary, El Paso County could potentially install this lane concurrent with the second southbound left-turn lane (discussed in the paragraph above).
- For 2040, LSC assumed Marksheffel widened to four through lanes and the long-term analysis assumed a (westbound to) northbound acceleration lane would be incorporated into a project to widen Marksheffel Road to a multi-lane facility.

ROADWAY IMPROVEMENT FEE PROGRAM

This project will be required to participate in the El Paso County Road Improvement Fee Program. The Ridge at Lorson Ranch will join the ten-mil PID. The ten-mil PID building-permit fee portion associated with this option is \$1,221 per single-family dwelling unit. The building-permit fees would be \$653,235 for Filing No. 1, \$338,217 for Filing No. 2, and \$222,222 for Filing No. 3.

* * * * *

Please contact me if you have any questions regarding this report.

Respectfully submitted,

LSC TRANSPORTATION CONSULTANTS, INC.

By: Jeffrey C. Hodsdon, P.E.
Principal

JCH/KDF:jas

Enclosures: Figure 1
Tables 1-4
Table 4 from *The Ridge at Lorson Ranch Full Traffic Impact Analysis*
Traffic Count Data
Crash History Data
Development Agreement

Figure 1



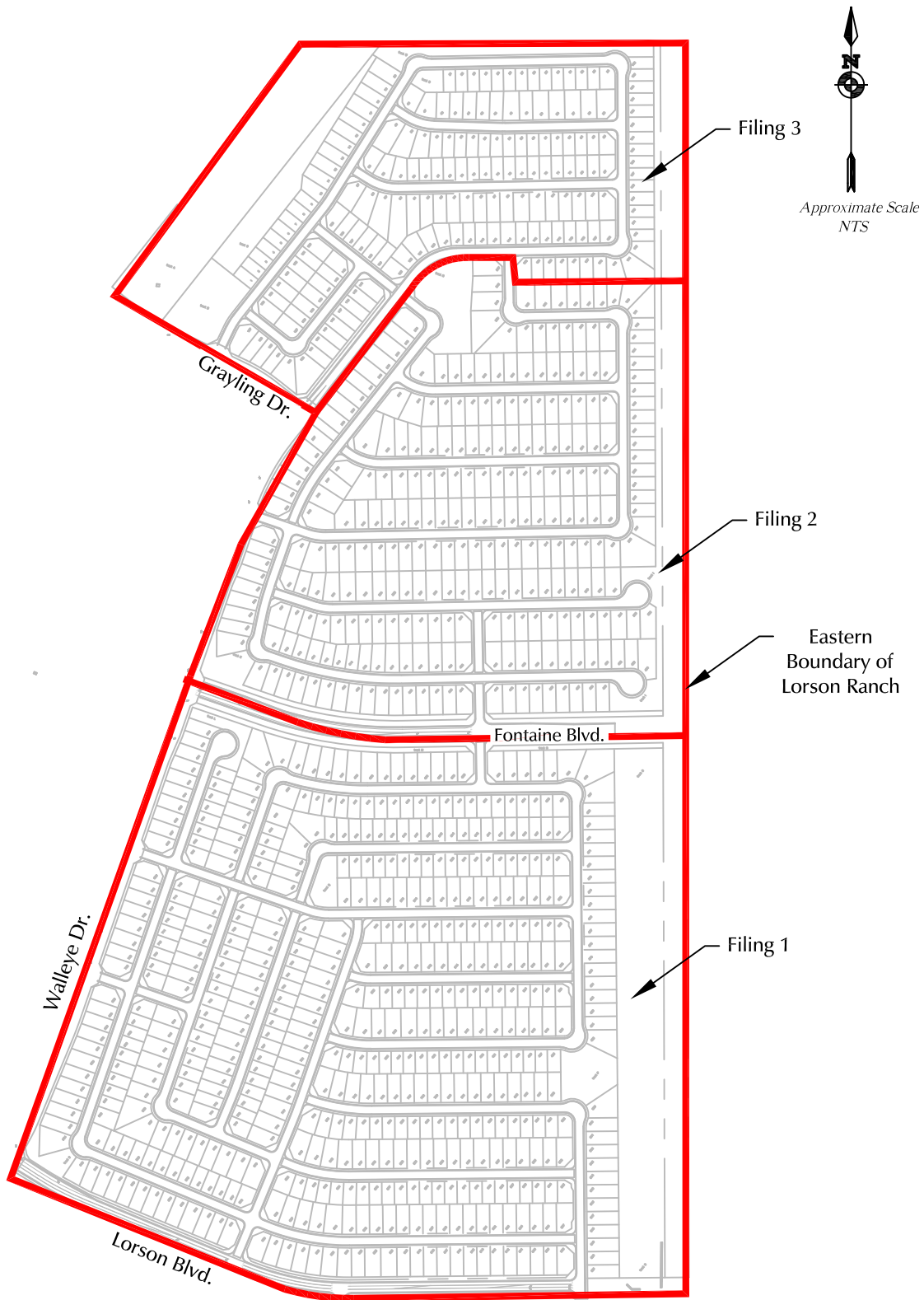

Figure 1
Vicinity Map
 Ridges at Lorson Ranch Final Plats (LSC #S214082)

Tables 1-4



**Table 1
Trip Generation Estimate
Ridges at Lorson Ranch Filing No. 1-3**

Currently Proposed Filing	Traffic Analysis Zone	Land Use Code	Land Use Description	Trip Generation Units	Trip Generation Rates ⁽¹⁾					Total Trips Generated				
					Average Weekday Traffic	Morning Peak Hour		Afternoon Peak Hour		Average Weekday Traffic	Morning Peak Hour		Afternoon Peak Hour	
						In	Out	In	Out		In	Out	In	Out
Trip Generation Estimate Based on the Currently Proposed Plan														
1	35	210	Single-Family Detached Housing	535 DU ⁽²⁾	9.43	0.18	0.52	0.59	0.35	5,045	97	277	317	186
2	46	210	Single-Family Detached Housing	277 DU	9.43	0.18	0.52	0.59	0.35	2,612	50	143	164	96
3		210	Single-Family Detached Housing	182 DU	9.43	0.18	0.52	0.59	0.35	1,716	33	94	108	63
Total Filings 1-3				994 DU						9,373	181	515	589	346
Trip Generation From the Ridges at Lorson Ranch Traffic Impact Analysis PUD SP-216, November 5, 2021⁽³⁾														
---	35	210	Single-Family Detached Housing	459 DU	9.44	0.19	0.56	0.62	0.37	4,333	85	255	286	168
---	46	210	Single-Family Detached Housing	535 DU	9.44	0.19	0.56	0.62	0.37	5,050	99	297	334	196
				994 DU						9,383	184	552	620	364
Change (Decrease) In Trip Generation Estimate										-10	-3	-37	-31	-18

Notes:

(1) Source: "Trip Generation, 11th Edition, 2017" by the Institute of Transportation Engineers (ITE)

(2) DU = dwelling unit

(3) Trip Generation Estimates in the November 2021 PUD TIS were based on "Trip Generation, 10th Edition, 2017" by ITE

Table 2
Traffic Signal Warrant Analysis
 Marksheffle/Lorson

Warrant Analysis ⁽²⁾										
Traffic Volumes ⁽¹⁾			Warrant 1: Eight Hour Vehicular Volume Evaluation						Warrant 2: Four Hour Vehicular Volume Evaluation	
			Warrant Thresholds				Warrant Threshold Met?		70% Warrant Threshold Minor Minimum	Warrant Threshold Met?
Hour	Major ⁽³⁾ Marksheffel	Minor ⁽⁴⁾ Lorson WB LT	Condition A (70%)		Condition B (70%)		Condition A	Condition B		
			Major	Minor	Major	Minor	WB	WB		
6:00 - 7:00	711	148	350	105	525	53	Yes	Yes	69	Yes
7:00 - 8:00	1161	184	350	105	525	53	Yes	Yes	60	Yes
8:00 - 9:00	786	192	350	105	525	53	Yes	Yes	61	Yes
11:00 - 12:00	568	107	350	105	525	53	Yes	Yes	101	Yes
12:00 - 13:00	590	102	350	105	525	53	No	Yes	94	Yes
15:00 - 16:00	1029	109	350	105	525	53	Yes	Yes	60	Yes
16:00 - 17:00	1170	93	350	105	525	53	No	Yes	60	Yes
17:00 - 18:00	1279	115	350	105	525	53	Yes	Yes	60	Yes

Number of hours the thresholds are met Warrant met?	6	8	8
	Yes		Yes

Notes:

- (1) Based on counts by LSC March 2022
- (2) Thresholds are based on 1 lane on the major approach and 1 lane on the minor approach with the 70% factor applied for a posted speed limit above 40 mph
- (2) The major street traffic includes all movements (left, through, and right) on Marksheffel Road
- (3) The minor street traffic includes only the westbound left turning movements from Lorson Blvd

Source: LSC Transportation Consultants, Inc.

Table 3
Signal Escrow Analysis Table
 Old Glory/Fontaine Intersection
 The Ridge at Lorson Ranch

Development	Minor Approach Volume ⁽¹⁾		Fair Share		Amount (Based on a \$300,000 signal cost)
	AM	PM	All Traffic	Future Development Only	
Based on Projected 2040 Total Traffic Volumes					
Existing Traffic	166	56	42.2%	---	
Creekside at Lorson Ranch (platted)	19	14	6.3%	---	
Lorson Ranch East Fil 4	19	15	6.5%	---	
Creekside South at Lorson Ranch	45	33	14.8%	32.9%	\$98,734
Ponderosa at Lorson Ranch Fil 3	6	3	1.7%	3.8%	\$11,392
The Hills at Lorson Ranch	8	5	2.5%	5.5%	\$16,456
Future Multi-family SW Lorson/Trappe	13	8	4.0%	8.9%	\$26,582
Ridge at Lorson Ranch	Fil 1 (535 lots)	7	2.3%	5.1%	\$8,176
	Fil 2 (277 lots)				\$4,233
	Fil 3 (182 lots)				\$2,781
Future Development East of Powerline Easement	60	44	19.8%	43.9%	\$131,646
	343	183			\$300,000
Notes:					
(1) Minor approach volume includes all northbound and southbound left-turn and through movements. Right-turn movements have been excluded as there are existing dedicated right-turn lanes on both approaches.					
Source: LSC Transportation Consultants, Inc.					Mar-22

Table 4
Lorson Boulevard/Marksheffel Road Future Traffic Signal Contributions
Ridge at Lorson Ranch

Subdivision	Dwelling Units	Previously Identified Signal Contribution	Currently Proposed Signal Contribution	Remaining Needed (Based on \$590,000 Total Cost)
Existing Subdivisions:				
Carriage Meadows South at Lorson Ranch Filing No. 1 ⁽¹⁾		\$115,302		\$474,698
Lorson Ranch East Filing No. 1 ⁽²⁾		\$86,003		\$388,695
Lorson Ranch East Filing No. 2 ⁽³⁾		\$0		\$388,695
Lorson Ranch East Filing No. 3 ⁽⁴⁾		\$0		\$388,695
Lorson Ranch East Filing No. 4 ⁽⁵⁾		\$68,801		\$319,894
Carriage Meadows Townhomes ⁽⁶⁾		\$10,453		\$309,441
Creekside at Lorson Ranch Filing No. 1 ⁽⁷⁾		\$19,441		\$290,000
		\$300,000		
Short-Term Future Subdivisions:				
Creekside at Lorson Ranch Filing 2	31 2%		\$5,938	\$284,062
Hillside at Lorson Ranch	489 32%		\$93,666	\$190,396
Ridge at Lorson Ranch Fil 1	535 35%		\$102,477	\$87,919
Ridge at Lorson Ranch Fil 2	277 18%		\$53,058	\$34,861
Ridge at Lorson Ranch Fil 3	182 12%		\$34,861	\$0
	1,514		\$290,000	

Notes:

- (1) *Carriage Meadows South at Lorson Ranch Filing No 1 Updated Traffic Impact Analysis* by LSC August 14, 2017
- (2) *Lorson Ranch East Filing No 1 Transportation Memorandum* by LSC May 2, 2018
- (3) *Lorson Ranch East Filing No 2 Transportation Memorandum* by LSC September 24, 2018
- (4) *Lorson Ranch East Filing No 3 Transportation Memorandum* by LSC January 22, 2019
- (5) *Lorson Ranch East Filing No 4 Transportation Memorandum* by LSC March 12, 2019
- (6) *Carriage Meadows Townhomes Traffic Impact Analysis* by LSC April 10, 2019
- (7) *Creekside at Lorson Ranch Filing No. 1 Transportation Memorandum* by LSC April 26, 2019

Additional Attachments

Table 4 from *The Ridge at Lorson Ranch Full Traffic Impact Analysis*



Table 4
Page 1 of 2
The Ridges at Lorson Ranch
Roadway Improvements

Item #	Improvement	Improvement Description With Details	Trigger	Timing	Responsibility
Roadway Segment Improvements					
1	Roadway Segment	Construct Fontaine Boulevard from its existing terminus to Walleye Drive as an Interim 2-Lane Urban Non-Residential Collector in 100' right-of-way	With The Hills at Lorson Ranch	With The Hills at Lorson Ranch	Lorson Ranch
2	Roadway Segment	Construct Fontaine Boulevard from Walleye Drive to the east boundary of Lorson Ranch as an interim 2-Lane Urban Non-Residential Collector in 100' right-of-way	With The Ridges at Lorson Ranch	With The Ridge at Lorson Ranch Fil 1	Lorson Ranch
3	Roadway Segment	Construct Lorson Boulevard from Lamprey Drive to Walleye Drive as an Urban Residential Collector with 64' - 72' of right-of-way	With The Hills at Lorson Ranch	With The Hills at Lorson Ranch	Lorson Ranch
4	Roadway Segment	Construct Lorson Boulevard from Walleye Drive to its planned ultimate terminus as an Urban Residential Collector with 60' of right-of-way	With The Ridges at Lorson Ranch	With The Ridge at Lorson Ranch Fil 1	Lorson Ranch
5	Roadway Segment	Construct Walleye Drive from Lorson Boulevard to Grayling Drive as an Urban Residential Collector with 64' to 72' of right-of-way	With The Hills at Lorson Ranch	With The Hills at Lorson Ranch	Lorson Ranch
6	Roadway Segment	Construct Grayling Drive from Lamprey Drive to Walleye Drive as an Urban Residential Collector with 60' of right-of-way	With The Hills at Lorson Ranch	With The Hills at Lorson Ranch	Lorson Ranch
7	Roadway Segment	Construct Grayling Drive from Walleye Drive to the north boundary of Lorson Ranch as an Urban Residential Collector with 64' to 72' of right-of-way	With The Skyline at Lorson Ranch	With The Skyline at Lorson Ranch	Lorson Ranch
Intersection #1 Marksheffel/Fontaine					
8	Traffic Signal Improvements	Add protected phasing for left-turn movements	When warrant(s) are met	With The Ridge at Lorson Ranch Fil 3	Lorson Ranch El Paso County with escrow depending on warrants
9	Second southbound left-turn lane	Add a second southbound left-turn lane on Marksheffel Road approaching Fontaine Boulevard	left turn volume > 505 vehicles per hour	Turning Volume trigger estimated to be reached with development of The Ridge at Lorson Ranch Fil 2	Lorson Ranch El Paso County with escrow depending on warrants
Intersection #2 Old Glory/Fontaine					
10	All-Way Stop Control	Convert from two-way stop-sign control to all-way stop-sign control	When warrant(s) are met	With The Hills at Lorson Ranch	Lorson Ranch
11	Traffic Signal Control	Convert from all-way stop-sign control to traffic signal control	When warrant(s) are met and The Level of Service degrades below an acceptable level (LOS D)	Anticipated to be met prior to buildout of The Hills at Lorson Ranch	Lorson Ranch
Intersection #3 Old Glory/Stingray/Fontaine					
12	Access Restriction	Construct a median on Fontaine Boulevard to restrict the intersection of Old Glory/Stingray/Fontaine to three-quarter movement (left-in/right-in/right-out only) or Construct a median on Fontaine Boulevard to create a channelized "T" intersection for the north leg with a protected eastbound left-turn acceleration lane. The southbound leg would be restricted to right-in/right-out only	When the LOS degrades below LOS D	With The Hills at Lorson Ranch	Lorson Ranch
Intersection #5 Marksheffel/Lorson					
13	Traffic Signal Control	Convert to traffic signal control	When warrant(s) are met and The Level of Service degrades below an acceptable level (LOS D)	Currently Met	Lorson Ranch
Intersection #7 Grayling/Regan Ridge					
14	Southeastbound left-turn lane	Southeastbound left-turn lane on Grayling approaching Regan Ridge	left turn volume > 25 vehicles per hour		NOT REQUIRED
15	Southeastbound right-turn deceleration lane	Southeastbound right-turn deceleration lane on Grayling approaching Regan Ridge	right turn volume > 50 vehicles per hour		NOT REQUIRED
16	Northwestbound left-turn lane	Northwestbound left-turn lane on Grayling approaching Regan Ridge	left turn volume > 25 vehicles per hour		NOT REQUIRED
17	Northwestbound right-turn deceleration lane	Northwestbound right-turn deceleration lane on Grayling approaching Regan Ridge	right turn volume > 50 vehicles per hour		NOT REQUIRED
Intersection #8 Grayling/Walleye					
18	Southeastbound left-turn lane	Southeastbound left-turn lane on Grayling approaching Walleye	left turn volume > 25 vehicles per hour		NOT REQUIRED
19	Northwestbound left-turn lane	Northeastbound left-turn lane on Walleye approaching Grayling	left turn volume > 25 vehicles per hour		NOT REQUIRED
Intersection #9 Walleye/Sanderling					
20	Southbound left-turn lane	Southbound left-turn lane on Walleye approaching Sanderling (recommended length: 205' turn lane plus 160' taper)	left turn volume > 25 vehicles per hour	NOT REQUIRED short left-turn bay recommended to match the northbound left-turn lane (will be included with street construction/in the cross section)	Lorson Ranch
21	Southbound right-turn deceleration lane	Southbound right-turn deceleration lane on Walleye approaching Sanderling	right turn volume > 50 vehicles per hour		NOT REQUIRED
22	Northbound left-turn lane	Northbound left-turn lane on Walleye approaching Sanderling (recommended length: 205' turn lane plus 160' taper)	left turn volume > 25 vehicles per hour	With The Hills at Lorson Ranch	Lorson Ranch
23	Northbound right-turn deceleration lane	Northbound right-turn deceleration lane on Walleye approaching Sanderling (recommended length: 155' turn lane plus 160' taper)	right turn volume > 50 vehicles per hour	With The Ridge at Lorson Ranch Fil 2	Lorson Ranch

Source: LSC Transportation Consultants, Inc. (March 2021)

w/notations from March 2022 and June 21, 2022

Taken from *The Ridge at Lorson Ranch Full Traffic Impact Analysis PUDSP203* dated October 8, 2021 with updated notes by LSC March 2022

June 21, 2022 modifications shown in this color scheme

(See Table 3 for Recommended Escrow Contributions by Filing)

Traffic Counts



LSC Transportation Consultants, Inc.

2504 E Pikes Peak Ave, Suite 304
 Colorado Springs, CO 80909
 719-633-2868

File Name : Marksheffel Rd - Lorson Blvd AM 3-1 SW
 Site Code : S214080
 Start Date : 3/1/2022
 Page No : 1

Groups Printed- Unshifted

Start Time	Marksheffel Rd Southbound					Lorson Blvd Westbound					Marksheffel Rd Northbound					Eastbound					Int. Total
	L	T	R	U	App. Total	L	T	R	U	App. Total	L	T	R	U	App. Total	L	T	R	U	App. Total	
06:00 AM	0	36	0	0	36	31	0	9	0	40	0	69	6	0	75	0	0	0	0	0	151
06:15 AM	4	55	0	0	59	34	0	10	0	44	0	85	8	0	93	0	0	0	0	0	196
06:30 AM	0	86	0	0	86	32	0	18	0	50	0	118	10	0	128	0	0	0	0	0	264
06:45 AM	9	90	0	0	99	51	0	20	0	71	0	114	21	0	135	0	0	0	0	0	305
Total	13	267	0	0	280	148	0	57	0	205	0	386	45	0	431	0	0	0	0	0	916
07:00 AM	11	92	0	0	103	50	0	32	0	82	0	153	18	0	171	0	0	0	0	0	356
07:15 AM	14	111	0	0	125	37	0	36	1	74	0	177	34	0	211	0	0	0	0	0	410
07:30 AM	14	104	0	0	118	41	0	28	0	69	0	144	37	0	181	0	0	0	0	0	368
07:45 AM	9	90	0	0	99	56	0	24	0	80	0	110	43	0	153	0	0	0	0	0	332
Total	48	397	0	0	445	184	0	120	1	305	0	584	132	0	716	0	0	0	0	0	1466
08:00 AM	10	96	0	0	106	45	0	13	0	58	0	73	31	0	104	0	0	0	0	0	268
08:15 AM	11	92	0	0	103	61	0	10	0	71	0	103	29	0	132	0	0	0	0	0	306
08:30 AM	5	72	0	0	77	58	0	13	1	72	0	80	22	0	102	0	0	0	0	0	251
08:45 AM	12	68	0	0	80	28	0	15	0	43	0	61	21	0	82	0	0	0	0	0	205
Total	38	328	0	0	366	192	0	51	1	244	0	317	103	0	420	0	0	0	0	0	1030
Grand Total	99	992	0	0	1091	524	0	228	2	754	0	1287	280	0	1567	0	0	0	0	0	3412
Apprch %	9.1	90.9	0	0		69.5	0	30.2	0.3		0	82.1	17.9	0		0	0	0	0	0	
Total %	2.9	29.1	0	0	32	15.4	0	6.7	0.1	22.1	0	37.7	8.2	0	45.9	0	0	0	0	0	

LSC Transportation Consultants, Inc.

2504 E Pikes Peak Ave, Suite 304
 Colorado Springs, CO 80909
 719-633-2868

File Name : Marksheffel Rd - Lorson Blvd AM 3-1 SW
 Site Code : S214080
 Start Date : 3/1/2022
 Page No : 3

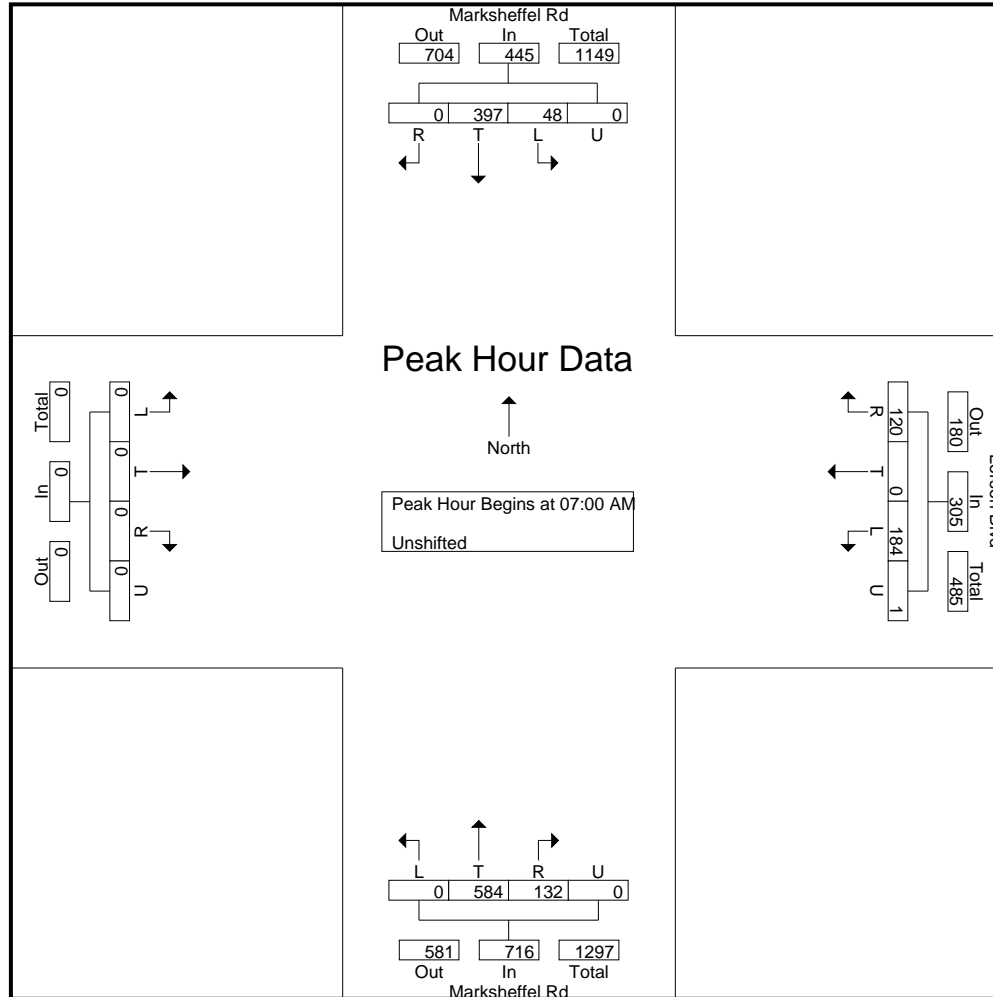

LSC Transportation Consultants, Inc.

2504 E Pikes Peak Ave, Suite 304
 Colorado Springs, CO 80909
 719-633-2868

File Name : Marksheffel Rd - Lorson Blvd Mid 3-1 SW
 Site Code : S224030
 Start Date : 3/2/2022
 Page No : 1

Groups Printed- Unshifted

Start Time	Marksheffel Rd Southbound					Lorson Blvd Westbound					Marksheffel Rd Northbound					Eastbound					Int. Total
	L	T	R	U	App. Total	L	T	R	U	App. Total	L	T	R	U	App. Total	L	T	R	U	App. Total	
11:00 AM	9	42	1	0	52	19	0	4	0	23	0	44	27	0	71	0	0	0	0	0	146
11:15 AM	5	51	0	0	56	34	0	7	0	41	0	56	21	0	77	0	0	0	0	0	174
11:30 AM	6	66	0	0	72	32	0	16	0	48	0	49	34	0	83	0	0	0	0	0	203
11:45 AM	4	57	0	0	61	22	0	10	0	32	0	64	33	0	97	0	0	0	0	0	190
Total	24	216	1	0	241	107	0	37	0	144	0	213	115	0	328	0	0	0	0	0	713
12:00 PM	0	55	0	0	55	23	0	9	0	32	0	68	20	0	88	0	0	0	0	0	175
12:15 PM	8	59	0	0	67	35	0	6	0	41	0	74	35	0	109	0	0	0	0	0	217
12:30 PM	3	48	0	0	51	22	0	14	0	36	0	55	27	0	82	0	0	0	0	0	169
12:45 PM	6	50	0	0	56	22	0	12	0	34	0	53	29	0	82	0	0	0	0	0	172
Total	17	212	0	0	229	102	0	41	0	143	0	250	111	0	361	0	0	0	0	0	733
Grand Total	41	428	1	0	470	209	0	78	0	287	0	463	226	0	689	0	0	0	0	0	1446
Apprch %	8.7	91.1	0.2	0		72.8	0	27.2	0		0	67.2	32.8	0		0	0	0	0	0	
Total %	2.8	29.6	0.1	0	32.5	14.5	0	5.4	0	19.8	0	32	15.6	0	47.6	0	0	0	0	0	

LSC Transportation Consultants, Inc.

2504 E Pikes Peak Ave, Suite 304
 Colorado Springs, CO 80909
 719-633-2868

File Name : Marksheffel Rd - Lorson Blvd Mid 3-1 SW
 Site Code : S224030
 Start Date : 3/2/2022
 Page No : 3

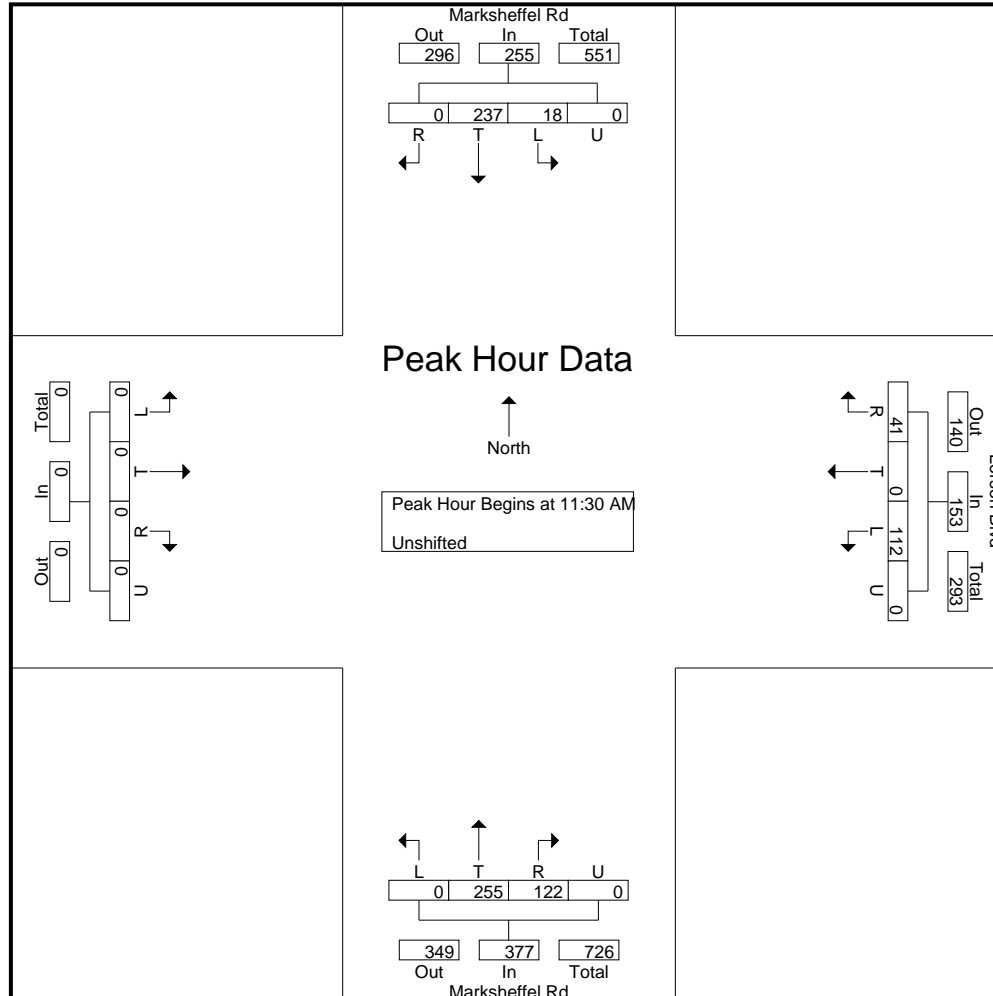

LSC Transportation Consultants, Inc.

2504 E Pikes Peak Ave, Suite 304
 Colorado Springs, CO 80909
 719-633-2868

File Name : Marksheffel Rd - Lorson Blvd PM 3-1 SW
 Site Code : S214080
 Start Date : 3/1/2022
 Page No : 1

Groups Printed- Unshifted

Start Time	Marksheffel Rd Southbound					Lorson Blvd Westbound					Marksheffel Rd Northbound					Eastbound					Int. Total
	L	T	R	U	App. Total	L	T	R	U	App. Total	L	T	R	U	App. Total	L	T	R	U	App. Total	
03:00 PM	9	85	0	0	94	25	0	16	0	41	0	91	48	0	139	0	0	0	0	0	274
03:15 PM	11	80	0	0	91	25	0	13	0	38	0	90	39	0	129	0	0	0	0	0	258
03:30 PM	10	108	0	0	118	29	0	10	0	39	0	115	43	0	158	0	0	0	0	0	315
03:45 PM	15	122	0	0	137	30	0	15	0	45	0	118	45	0	163	0	0	0	0	0	345
Total	45	395	0	0	440	109	0	54	0	163	0	414	175	0	589	0	0	0	0	0	1192
04:00 PM	11	110	0	0	121	22	0	13	0	35	0	102	63	0	165	0	0	0	0	0	321
04:15 PM	13	145	0	1	159	25	0	9	0	34	0	101	47	0	148	0	0	0	0	0	341
04:30 PM	20	121	0	0	141	23	0	16	0	39	0	91	50	0	141	0	0	0	0	0	321
04:45 PM	10	116	0	0	126	23	0	13	0	36	0	104	66	0	170	0	0	0	0	0	332
Total	54	492	0	1	547	93	0	51	0	144	0	398	226	0	624	0	0	0	0	0	1315
05:00 PM	10	126	0	0	136	29	0	14	0	43	0	132	84	0	216	0	0	0	0	0	395
05:15 PM	20	152	0	0	172	29	0	20	0	49	0	110	68	0	178	0	0	0	0	0	399
05:30 PM	14	118	0	0	132	40	0	13	0	53	0	103	59	0	162	0	0	0	0	0	347
05:45 PM	16	98	0	0	114	17	0	19	0	36	0	105	64	0	169	0	0	0	0	0	319
Total	60	494	0	0	554	115	0	66	0	181	0	450	275	0	725	0	0	0	0	0	1460
Grand Total	159	1381	0	1	1541	317	0	171	0	488	0	1262	676	0	1938	0	0	0	0	0	3967
Apprch %	10.3	89.6	0	0.1		65	0	35	0		0	65.1	34.9	0		0	0	0	0	0	
Total %	4	34.8	0	0	38.8	8	0	4.3	0	12.3	0	31.8	17	0	48.9	0	0	0	0	0	

LSC Transportation Consultants, Inc.

2504 E Pikes Peak Ave, Suite 304
 Colorado Springs, CO 80909
 719-633-2868

File Name : Marksheffel Rd - Lorson Blvd PM 3-1 SW
 Site Code : S214080
 Start Date : 3/1/2022
 Page No : 3

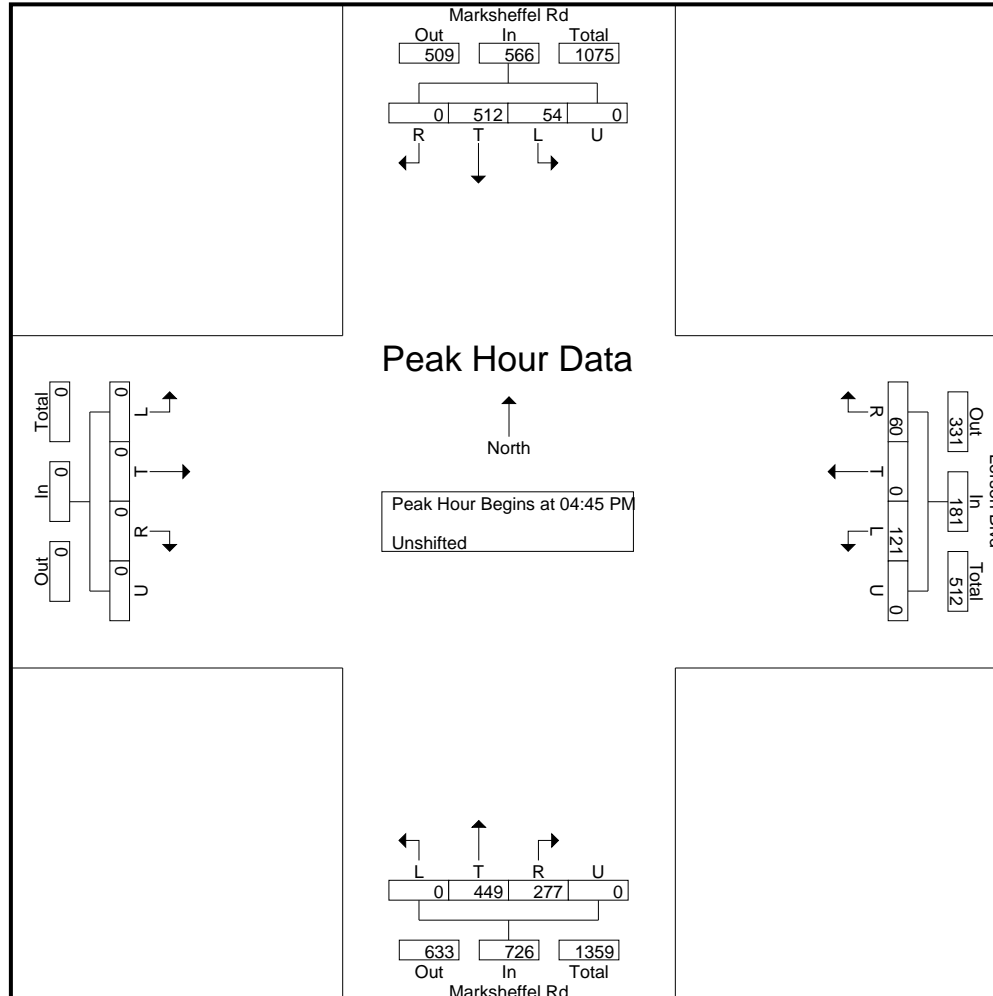

LSC Transportation Consultants, Inc.

2504 E. Pikes Peak Ave, Suite 304
 Colorado Springs, CO 80909
 719-633-2868

File Name : Marksheffel Rd - Fontaine Blvd AM 5-22

Site Code : S214080

Start Date : 5/26/2022

Page No : 1

Groups Printed- Unshifted

Start Time	Marksheffel Rd Southbound					Fontain Blvd Westbound					Marksheffel Rd Northbound					Fontaine Blvd Eastbound					Int. Total
	Right	Thru	Left	Peds	App. Total	Right	Thru	Left	Peds	App. Total	Right	Thru	Left	Peds	App. Total	Right	Thru	Left	Peds	App. Total	
06:30	2	53	19	0	74	68	55	23	0	146	7	117	10	0	134	3	22	7	0	32	386
06:45	2	48	24	0	74	71	44	27	0	142	22	114	10	0	146	11	25	5	0	41	403
Total	4	101	43	0	148	139	99	50	0	288	29	231	20	0	280	14	47	12	0	73	789
07:00	1	54	36	0	91	92	76	36	0	204	14	114	16	0	144	4	19	5	0	28	467
07:15	2	71	24	0	97	92	80	38	0	210	27	142	20	0	189	8	42	6	0	56	552
07:30	7	68	28	0	103	69	91	37	0	197	21	113	10	0	144	9	29	8	0	46	490
07:45	7	61	27	0	95	55	51	37	0	143	28	67	10	0	105	5	31	8	0	44	387
Total	17	254	115	0	386	308	298	148	0	754	90	436	56	0	582	26	121	27	0	174	1896
08:00	2	39	26	0	67	45	50	37	0	132	22	69	7	0	98	5	30	6	0	41	338
08:15	2	56	18	0	76	39	68	57	0	164	20	75	10	0	105	17	29	3	0	49	394
Grand Total	25	450	202	0	677	531	515	292	0	1338	161	811	93	0	1065	62	227	48	0	337	3417
Apprch %	3.7	66.5	29.8	0		39.7	38.5	21.8	0		15.1	76.2	8.7	0		18.4	67.4	14.2	0		
Total %	0.7	13.2	5.9	0	19.8	15.5	15.1	8.5	0	39.2	4.7	23.7	2.7	0	31.2	1.8	6.6	1.4	0	9.9	

LSC Transportation Consultants, Inc.

2504 E. Pikes Peak Ave, Suite 304
 Colorado Springs, CO 80909
 719-633-2868

File Name : Marksheffel Rd - Fontaine Blvd AM 5-22

Site Code : S214080

Start Date : 5/26/2022

Page No : 2

Start Time	Marksheffel Rd Southbound					Fontain Blvd Westbound					Marksheffel Rd Northbound					Fontaine Blvd Eastbound					Int. Total
	Right	Thru	Left	Peds	App. Total	Right	Thru	Left	Peds	App. Total	Right	Thru	Left	Peds	App. Total	Right	Thru	Left	Peds	App. Total	
Peak Hour Analysis From 6:30:00 AM to 8:15:00 AM - Peak 1 of 1																					
Peak Hour for Entire Intersection Begins at 6:45:00 AM																					
6:45:00 AM	2	48	24	0	74	71	44	27	0	142	22	114	10	0	146	11	25	5	0	41	403
7:00:00 AM	1	54	36	0	91	92	76	36	0	204	14	114	16	0	144	4	19	5	0	28	467
7:15:00 AM	2	71	24	0	97	92	80	38	0	210	27	142	20	0	189	8	42	6	0	56	552
7:30:00 AM	7	68	28	0	103	69	91	37	0	197	21	113	10	0	144	9	29	8	0	46	490
Total Volume	12	241	112	0	365	324	291	138	0	753	84	483	56	0	623	32	115	24	0	171	1912
% App. Total	3.3	66	30.7	0		43	38.6	18.3	0		13.5	77.5	9	0		18.7	67.3	14	0		
PHF	.429	.849	.778	.000	.886	.880	.799	.908	.000	.896	.778	.850	.700	.000	.824	.727	.685	.750	.000	.763	.866

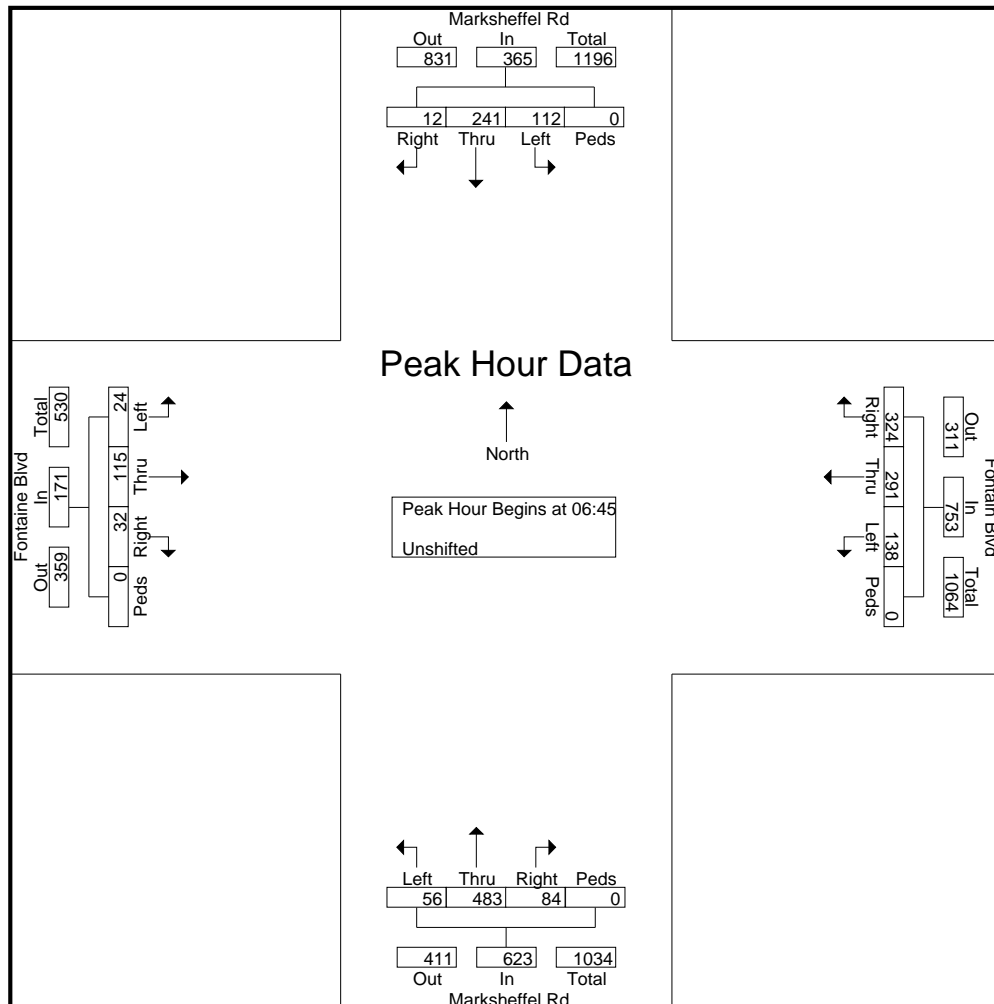

LSC Transportation Consultants, Inc.

2504 E. Pikes Peak Ave, Suite 304
 Colorado Springs, CO 80909
 719-633-2868

File Name : Marksheffel Rd - Fontaine Blvd AM 5-22

Site Code : S214080

Start Date : 5/26/2022

Page No : 3

Start Time	Marksheffel Rd Southbound					Fontain Blvd Westbound					Marksheffel Rd Northbound					Fontaine Blvd Eastbound					Int. Total
	Right	Thru	Left	Peds	App. Total	Right	Thru	Left	Peds	App. Total	Right	Thru	Left	Peds	App. Total	Right	Thru	Left	Peds	App. Total	
Peak Hour Analysis From 6:30:00 AM to 8:15:00 AM - Peak 1 of 1																					
Peak Hour for Each Approach Begins at:																					
	7:00:00 AM					7:00:00 AM					6:45:00 AM					7:15:00 AM					
+0 mins.	1	54	36	0	91	92	76	36	0	204	22	114	10	0	146	8	42	6	0	56	
+5 mins.	2	71	24	0	97	92	80	38	0	210	14	114	16	0	144	9	29	8	0	46	
+10 mins.	7	68	28	0	103	69	91	37	0	197	27	142	20	0	189	5	31	8	0	44	
+15 mins.	7	61	27	0	95	55	51	37	0	143	21	113	10	0	144	5	30	6	0	41	
Total Volume	17	254	115	0	386	308	298	148	0	754	84	483	56	0	623	27	132	28	0	187	
% App. Total	4.4	65.8	29.8	0		40.8	39.5	19.6	0		13.5	77.5	9	0		14.4	70.6	15	0		
PHF	.607	.894	.799	.000	.937	.837	.819	.974	.000	.898	.778	.850	.700	.000	.824	.750	.786	.875	.000	.835	

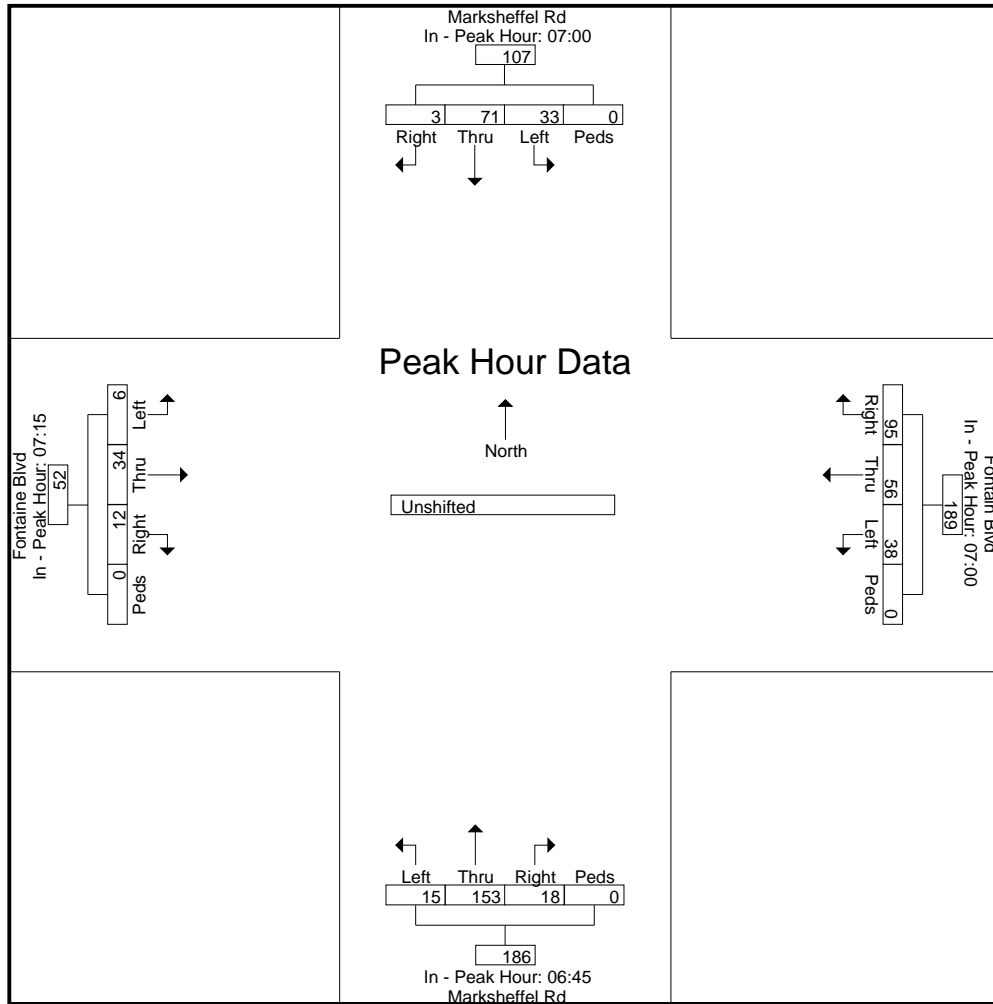

LSC Transportation Consultants, Inc.

2504 E. Pikes Peak Ave, Suite 304
 Colorado Springs, CO 80909
 719-633-2868

File Name : Marksheffel Rd - Fontaine Blvd PM 5-22

Site Code : S214080

Start Date : 5/25/2022

Page No : 1

Groups Printed- Unshifted

Start Time	Marksheffel Rd Southbound					Fontaine Blvd Westbound					Marksheffel Rd Northbound					Fontaine Blvd Eastbound					Int. Total
	Right	Thru	Left	Peds	App. Total	Right	Thru	Left	Peds	App. Total	Right	Thru	Left	Peds	App. Total	Right	Thru	Left	Peds	App. Total	
16:00	3	85	61	0	149	52	52	27	0	131	35	91	11	0	137	9	77	7	0	93	510
16:15	5	83	72	0	160	51	35	24	1	111	33	94	9	0	136	15	83	9	0	107	514
16:30	5	91	62	0	158	34	36	14	0	84	35	101	7	0	143	12	97	7	0	116	501
16:45	6	117	81	0	204	35	41	27	0	103	30	72	13	0	115	11	89	7	0	107	529
Total	19	376	276	0	671	172	164	92	1	429	133	358	40	0	531	47	346	30	0	423	2054
17:00	3	105	73	0	181	45	50	27	0	122	31	71	7	0	109	14	83	6	0	103	515
17:15	5	118	86	0	209	39	53	27	0	119	43	74	19	0	136	18	69	10	0	97	561
17:30	7	104	69	0	180	49	60	19	1	129	34	64	9	0	107	11	78	5	0	94	510
17:45	5	97	60	0	162	36	34	22	0	92	31	45	13	0	89	17	76	9	0	102	445
Total	20	424	288	0	732	169	197	95	1	462	139	254	48	0	441	60	306	30	0	396	2031
Grand Total	39	800	564	0	1403	341	361	187	2	891	272	612	88	0	972	107	652	60	0	819	4085
Apprch %	2.8	57	40.2	0		38.3	40.5	21	0.2		28	63	9.1	0		13.1	79.6	7.3	0		
Total %	1	19.6	13.8	0	34.3	8.3	8.8	4.6	0	21.8	6.7	15	2.2	0	23.8	2.6	16	1.5	0	20	

LSC Transportation Consultants, Inc.

2504 E. Pikes Peak Ave, Suite 304
 Colorado Springs, CO 80909
 719-633-2868

File Name : Marksheffel Rd - Fontaine Blvd PM 5-22

Site Code : S214080

Start Date : 5/25/2022

Page No : 2

Start Time	Marksheffel Rd Southbound					Fontaine Blvd Westbound					Marksheffel Rd Northbound					Fontaine Blvd Eastbound					Int. Total
	Right	Thru	Left	Peds	App. Total	Right	Thru	Left	Peds	App. Total	Right	Thru	Left	Peds	App. Total	Right	Thru	Left	Peds	App. Total	
Peak Hour Analysis From 4:00:00 PM to 5:45:00 PM - Peak 1 of 1																					
Peak Hour for Entire Intersection Begins at 4:45:00 PM																					
4:45:00 PM	6	117	81	0	204	35	41	27	0	103	30	72	13	0	115	11	89	7	0	107	529
5:00:00 PM	3	105	73	0	181	45	50	27	0	122	31	71	7	0	109	14	83	6	0	103	515
5:15:00 PM	5	118	86	0	209	39	53	27	0	119	43	74	19	0	136	18	69	10	0	97	561
5:30:00 PM	7	104	69	0	180	49	60	19	1	129	34	64	9	0	107	11	78	5	0	94	510
Total Volume	21	444	309	0	774	168	204	100	1	473	138	281	48	0	467	54	319	28	0	401	2115
% App. Total	2.7	57.4	39.9	0		35.5	43.1	21.1	0.2		29.6	60.2	10.3	0		13.5	79.6	7	0		
PHF	.750	.941	.898	.000	.926	.857	.850	.926	.250	.917	.802	.949	.632	.000	.858	.750	.896	.700	.000	.937	.943

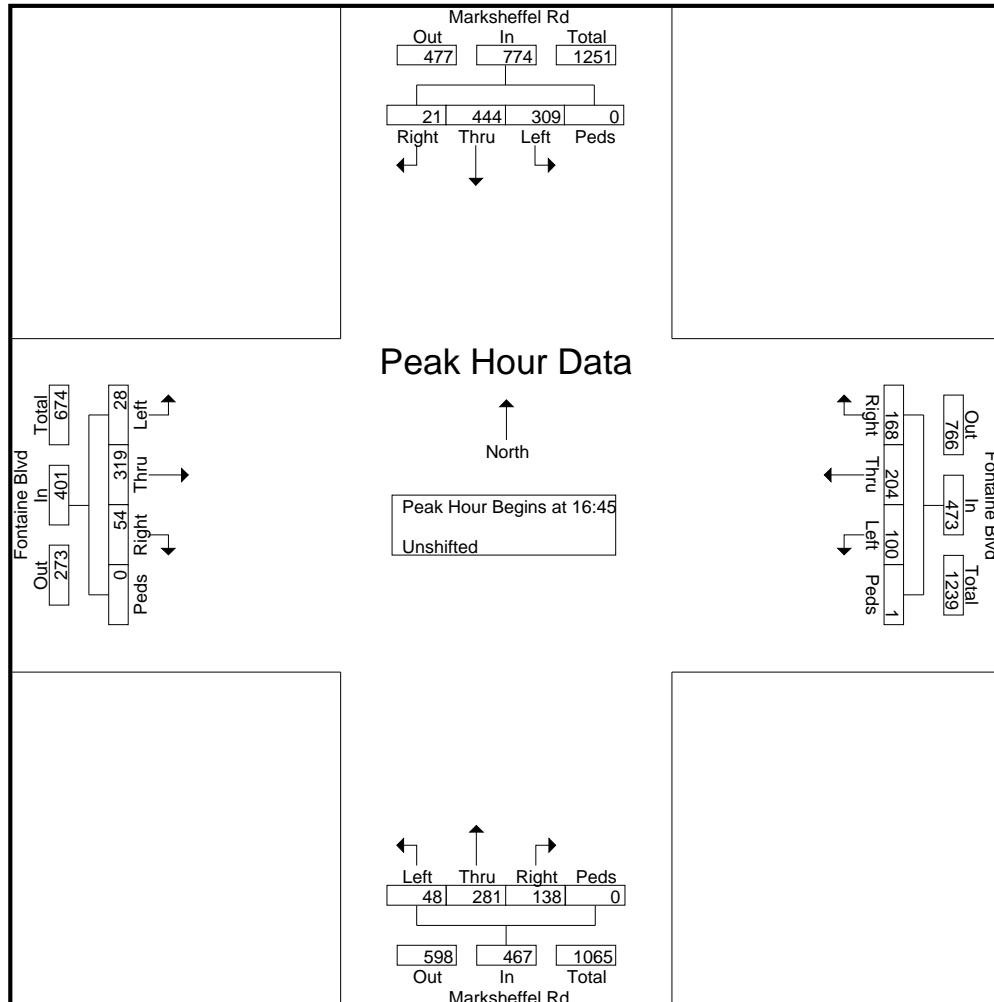

LSC Transportation Consultants, Inc.

2504 E. Pikes Peak Ave, Suite 304
Colorado Springs, CO 80909
719-633-2868

File Name : Marksheffel Rd - Fontaine Blvd PM 5-22

Site Code : S214080

Start Date : 5/25/2022

Page No : 3

Start Time	Marksheffel Rd Southbound					Fontaine Blvd Westbound					Marksheffel Rd Northbound					Fontaine Blvd Eastbound					Int. Total
	Right	Thru	Left	Peds	App. Total	Right	Thru	Left	Peds	App. Total	Right	Thru	Left	Peds	App. Total	Right	Thru	Left	Peds	App. Total	
Peak Hour Analysis From 4:00:00 PM to 5:45:00 PM - Peak 1 of 1																					
Peak Hour for Each Approach Begins at:																					
	4:45:00 PM					4:45:00 PM					4:00:00 PM					4:15:00 PM					
+0 mins.	6	117	81	0	204	35	41	27	0	103	35	91	11	0	137	15	83	9	0	107	
+5 mins.	3	105	73	0	181	45	50	27	0	122	33	94	9	0	136	12	97	7	0	116	
+10 mins.	5	118	86	0	209	39	53	27	0	119	35	101	7	0	143	11	89	7	0	107	
+15 mins.	7	104	69	0	180	49	60	19	1	129	30	72	13	0	115	14	83	6	0	103	
Total Volume	21	444	309	0	774	168	204	100	1	473	133	358	40	0	531	52	352	29	0	433	
% App. Total	2.7	57.4	39.9	0		35.5	43.1	21.1	0.2		25	67.4	7.5	0		12	81.3	6.7	0		
PHF	.750	.941	.898	.000	.926	.857	.850	.926	.250	.917	.950	.886	.769	.000	.928	.867	.907	.806	.000	.933	

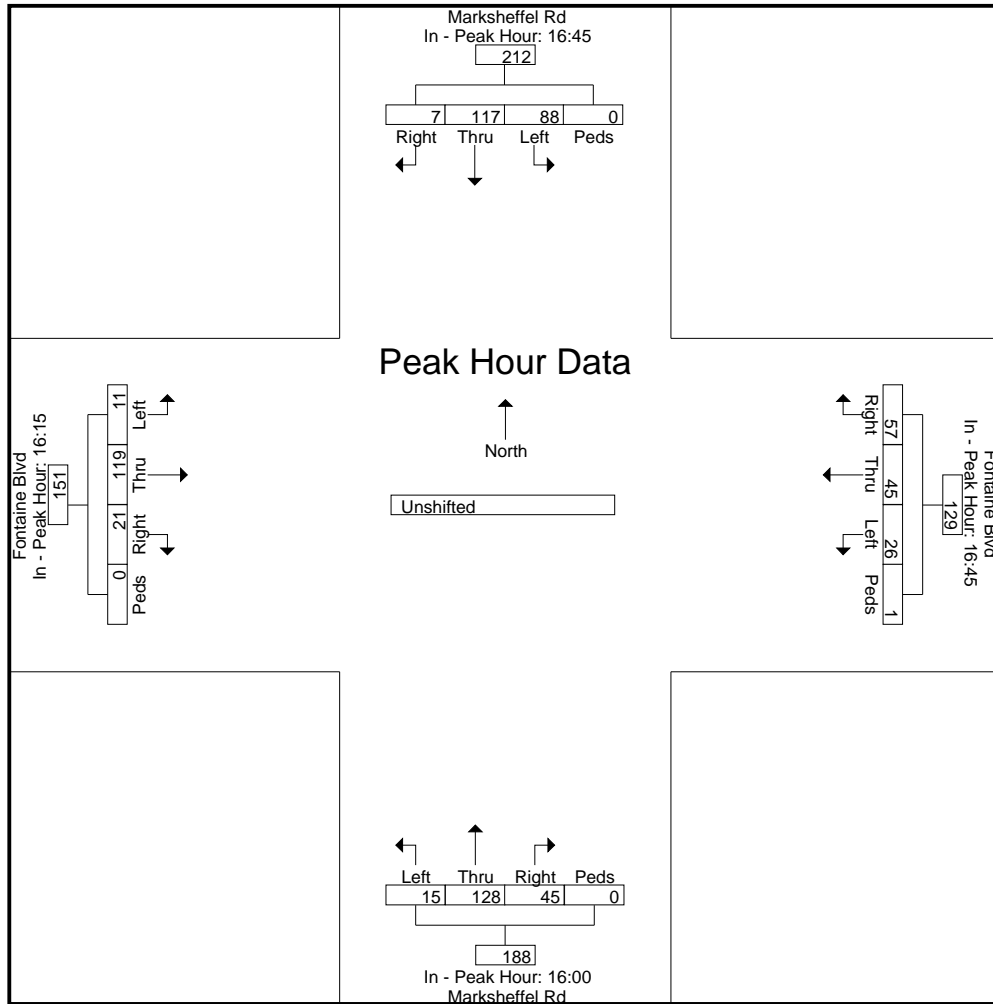

Crash History



AccidentDate	AccidentTime	TotalVehicles	ReferencePointName	ReferencePointAtName	AccidentNarrative
7/12/2019	23:15	1	MARKSHEFFEL RD	LORSON BLVD	Vehicle #1 was traveling southbound on Marksheffel Rd approaching Lorson Blvd. Vehicle #1 made a left turn onto Larson Blvd. Vehicle #1 went off the south side of Lorson Blvd into a ditch. The occupants fled to scene.
2/11/2021	16:40	3	MARKSHEFFEL RD	LORSON BLVD	Vehicle #1 was west on Lorson Boulevard, turning left to go south onto Marksheffel Road. Vehicle #2 was north on Marksheffel Road, when Vehicle #1 pulled into the intersection causing Vehicle #2 to collide its front into the rear driver side of Vehicle #1. After colliding with Vehicle #1, Vehicle #2 continued northbound and collided its front with Vehicle #3, which was stopped in traffic facing south in the left turn lane to go east on Lorson Boulevard. Vehicle #1 spun counterclockwise 1/2 times before coming to final rest facing east on the northeast corner of Marksheffel Road/Lorson Boulevard. Vehicles #2 and #3 came to final rest on thier wheels, with Vehicle #2 facing north and #3 facing south.
2/12/2021	10:01	2	MARKSHEFFEL RD	LORSON BLVD	Vehicle 1 and Vehicle 2 were traveling westbound Lorson Boulevard approaching Marksheffel Road. Vehicle 2 stopped at the stop sign in the right turn lane. Vehicle 1 was unable to stop due to icy road conditions. Vehicle 1 collided with the rear of Vehicle 2. Both vehicles moved onto the dirt shoulder on Marksheffel Road facing south.
8/16/2021	09:39	2	MARKSHEFFEL RD	LORSON BLVD	Vehicle 1 was westbound on Lorson Boulevard and stopped, at a stop sign, in the left turn lane. Vehicle 2 was northbound on Marksheffel Road. Vehicle 2 continued northbound. Vehicle 1 turned left onto Marksheffel Road and struck Vehicle 2, on its right side with its front. Vehicle 1 was driven to rest. After POI, Vehicle 2 rotated clockwise and came to rest, on its wheels, facing southeast.
9/17/2021	17:26	2	MARKSHEFFEL RD	LORSON BLVD	Vehicle 1 was stopped on Lorson Blvd facing west at the intersection of S Marksheffel Rd. Vehicle 2 was traveling northbound on S Marksheffel Rd approaching the intersection of Lorson Blvd. Vehicle 1 entered the intersection as Vehicle 2 was crossing the intersection and the front left of Vehicle 1 impacted the right rear of Vehicle 2. Vehicle 1 and Vehicle 2 moved from final rest.
11/1/2021	04:16	1	LORSON BLVD	MARKSHEFFEL RD	Vehicle 1 was west on Lorson Blvd approaching Marksheffel Rd. Vehicle 1 continued west across Marksheffel and proceeded off the west side of the roadway. Vehicle 1 hit the ditch proceeded airborne over a barbed wire fence. Vehicle 1 returned back to the ground in a field before coming to final rest facing west.
12/8/2021	18:57	2	MARKSHEFFEL RD	LORSON BLVD	Vehicle #1 was stopped at the intersection of Marksheffel Road and Lorson Blvd attempting to turn right onto Marksheffel Road. Vehicle #2 was traveling northbound on Marksheffel Road approaching Lorson Blvd. Vehicle #1 failed to yield right of way from a stop sign and Vehicle #1 front collided with Vehicle #2 side. After the collision Vehicle #1 came to final rest on the edge of Marksheffel Road on all 4 tires facing Northeast, and vehicle #2 ran off the right side of the roadway and came to final rest 200 in the field facing East.
1/28/2022	15:56	2	MARKSHEFFEL RD	LORSON BLVD	Vehicle #1 was stopped at the intersection of Marksheffel Road and Lorson Blvd attempting to make a left turn (South) on to Marksheffel Road. Vehicle #2 was traveling northbound on Marksheffel Road approaching the intersection at Marksheffel Road and Lorson Blvd. Vehicle #1 failed to yield right of way from a stop sign turning left and Vehicle #2 front collided with Vehicle #1 side. After the collision Vehicle #1 rolled 1/2 time and came to final rest on its right side facing northbound and Vehicle #2 came to final rest on the right side (East) of the roadway facing northbound.

Additional Attachments

Development Agreement



Resolution No. 12-196

BOARD OF COUNTY COMMISSIONERS
COUNTY OF EL PASO, STATE OF COLORADO

Resolution to Approve a Fourth Amended Development Agreement with Lorson Ranch Metropolitan District that Amends Previous Development Agreements in Order to be More Equitable With Respect to the District's Future Public Infrastructure Obligations and to Identify Credits for Public Improvements Already Constructed.

WHEREAS, pursuant to §§30-11-101(1)(d), 30-11-103, and 30-11-107(1)(e) & (h), C.R.S., the Board of County Commissioners of El Paso County, Colorado (hereinafter "Board") has the legislative authority to make all contracts and to perform duties respecting roads running into or through the County, when deemed by the Board to be in the best interests of the County; and

WHEREAS, Lorson Ranch Metropolitan District, a political subdivision of the State of Colorado (hereinafter "District") received authorization from the Board to build public improvements without first having to collateralize the improvements or obtain approval through the County's subdivision process on a parcel of land consisting of 1,366 acres known as the Lorson Ranch, which is located within the boundaries of the Lorson Ranch Metropolitan District Nos. 1, 2, 3, 4, 5, 6, and 7; and

WHEREAS, the Board and the District have entered into Development Agreement Nos. 1, 2, and 3 ((respectively approved on August 17, 2005, April 20, 2010, and December 10, 2011), and Lorson, LLC and the District have substantially completed construction and installation of public improvements as required under said Development Agreements; and

WHEREAS, the Board and the District desire to enter into a more equitable agreement with respect to the District's future public infrastructure obligations to be made next to the intersection of Fontaine and Marksheffel and to identify credits for public improvements already constructed; and

WHEREAS, the Board has determined that it would serve the best interests of the public to approve the Fourth Amended Development Agreement to effectuate the hereinabove described transaction, a copy of which is attached hereto as Exhibit A, and is incorporated herein by this reference.

NOW, THEREFORE, BE IT RESOLVED the Board of County Commissioners hereby approves the Fourth Amended Development Agreement subject to the terms and conditions cited therein.

BE IT FURTHER RESOLVED, that Amy Lathen, duly elected, qualified member and Chair of the Board of County Commissioners, or Sallie Clark, duly elected, qualified member and Vice-Chair of the Board of County Commissioners is hereby

authorized and appointed on behalf of the Board to execute the Fourth Amended Development Agreement and any and all other documents necessary to carry out the intent of the Board as described herein.

DONE THIS 14th day of June, 2012, at Colorado Springs, Colorado.

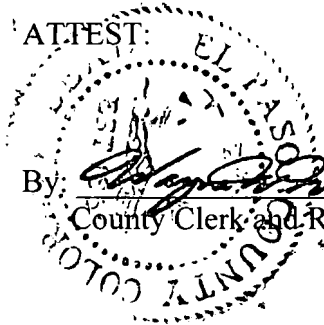
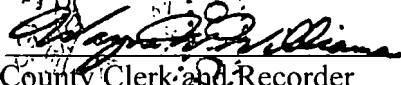
ATTEST:
The seal of El Paso County, Colorado, is circular with a central figure and the text "EL PASO COUNTY COLORADO" around the perimeter. The word "ATTEST:" is printed above the seal.
By: 
County Clerk and Recorder

BOARD OF COUNTY COMMISSIONERS
OF EL PASO COUNTY, COLORADO

By: 
Amy Lathen, Chair

Fourth Amended Development Agreement

THIS FOURTH AMENDED DEVELOPMENT AGREEMENT, is entered into by and between Lorson Ranch Metropolitan District (hereinafter "LRMD) and the County of El Paso, State of Colorado, a body corporate and politic and a political subdivision of the State of Colorado, (hereinafter "County"), by and through the Board of County Commissioners of El County, Colorado, (hereinafter "Board"). The County and the LRMD may be referred to hereinafter as the Parties.

Recitals

WHEREAS:

A. LRMD has substantially completed all construction and installation of its public infrastructure obligations as required under Development Agreement Numbers 1, 2 and 3 (respectively approved on August 17, 2005, April 20, 2010 and December 10, 2011) for the number of residential building permits issued in Lorson Ranch. However, with respect to LRMD's future public infrastructure obligations pertaining to improvements to be made at the intersection of Fontaine and Marksheffel, the County and LRMD mutually desire to enter into a more equitable agreement with respect to LRMD's future public infrastructure obligations to be made next to the intersection of Fontaine and Marksheffel.

B. The basis for the more equitable agreement is that LRMD, in contrast to other major development, installed approximately \$26 million in public drainage and off-site road improvements in advance and with the use of its own capital, thereby providing immediate public benefit while simultaneously relieving the public of the usual risks associated with new development's promise to construct public infrastructure. In addition, the LRMD anticipated recovery of a substantial part of its \$26 million in regional drainage and off-site improvements through the City-County Drainage Fee Reimbursement System and through the use of a County-staff recommended "small area plan".

C. LRMD, The Glen at Widefield, and Rolling Hills Ranch prepared a "small area traffic plan" for the Lorson, Rolling Hills Ranch and the Glen areas and obtained the El Paso County Planning Commission's approval of the Lorson Small Area Traffic Plan. However, the Board of County Commissioners did not consider the Planning Commission's recommendation for approval of the Small Area Traffic Plan, as the Board directed County staff to begin development of a plan for implementation of a county-wide transportation impact fee program. Although LRMD consented to the County's shift in policy focus to a county-wide fee program as a means to receive recovery for some of its off-site road improvements, the implementation of the fee program has been delayed and, therefore, LRMD has not yet had the opportunity to seek recovery of its investment in regional off-site road improvements. The Lorson Small Area Traffic Plan determined that LRMD would be eligible for reimbursement in the amount of at least

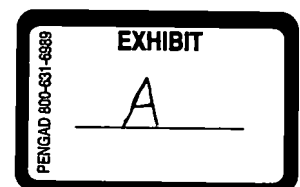

\$5,076,000 and which total amount will be reimbursed according to the provisions of Sections 3, 4 and 5, below.

D. LRMD contends that the County's delay in implementing of the county-wide transportation impact fee has cost the residents of Lorson Ranch approximately \$800,000 per year interest paid on the cost to construct the road improvements addressed in this Development Agreement. Accordingly, LRMD contends the delay in implementation has caused the residents of Lorson Ranch damages coincident with delay to be nearly \$4M in interest since 2007.

E. Although the County disagrees with LRMD's contentions as set forth above, the County agrees that it has taken longer than anticipated to implement the county-wide transportation impact fee program. Furthermore, since the time the County and LRMD originally entered into the Development Agreement, the County has downgraded the long-term traffic projects for Fontaine. Accordingly, if LRMD and the County sought to enter into a development agreement at this time, the County would not require LRMD to construct four lanes on Fontaine Boulevard and the County would not require LRMD to dedicate right of way sufficient for a major arterial. Therefore, the County agrees that fair and equitable modifications to the above-referenced Development Agreements are appropriate in order to resolve LRMD'S contentions.

F. The County and LRMD mutually desire to enter into this Fourth Amended Development Agreement.

NOW, THEREFORE, for and in consideration of the foregoing and the mutual promises contained herein, the sufficiency of which is hereby acknowledged, the Parties agree as set forth below.

AGREEMENT

1. All other terms and conditions of the above-referenced Development Agreements, except as expressly amended herein, shall remain in full force and effect.

2. The County, at its sole cost and expense, subject to funding from the PPRTA, shall install at the intersection of Fontaine and Marksheffel, temporary traffic light signalization for the entire intersection. Temporary traffic light signalization is defined for purposes of this agreement only as the traffic light signalization required for the same operation of the intersection using existing traffic volume as the baseline and as required for the safe operation of the intersection at the traffic volume including, but not to exceed, the anticipated traffic volume at the intersection when 775 single family residences have been sold in Lorson Ranch. At the point where traffic volume increases beyond the capacity and safety parameters of the temporary traffic light signalization, the County shall construct and install the permanent traffic light signalization at the County's cost and expense, inclusive of any PPRTA funding, and the County shall not impose the obligation, cost or expense on LRMD or upon any land use applications that may arise in the area covered under the above-referenced Development Agreements.. In addition, this

Fourth Amended Development Agreement establishes that Lorson shall have completed all of its obligations with respect to the intersection, and the County shall not hinder, delay, prohibit or in any way refuse to permit all or part of any development within the LRMD for any reason related to the capacity or safety of the intersection, the obligation for which shall remain with the County as per the provisions of the sentence immediately preceding.

3. For purposes of determining the amount of credits LRMD will receive under the County-Wide Transportation Impact Fee System, when implemented, County agrees that it shall use the methodology set forth in the proposed Lorson Area Small Traffic Plan and, therefore, will establish the credit LRMD will receive under the county-wide transportation impact fee system in the amount of \$4,100,000, exclusive of the amount of \$976,000, which latter amount the County will request from the Pikes Peak Regional Transportation Authority (PPRTA) pursuant to the provisions of Section 5, below. However, for purposes of receiving cash reimbursement from the county-wide transportation impact fee system this Agreement does not resolve where LRMD's entitlement to credits shall fall in the priority system that is still under development as part of the process to implement the County-Wide Transportation Impact Fee System. County represents that any such priority system shall be an objective system that determines priority based on objective factors such as date of substantial completion of the public road improvements.

4. In order to receive the credits LRMD shall participate in the county-wide transportation impact fee system (LRMD is currently exempted from participation in the program). However, a person or entity in the LRMD shall not have any obligation to pay cash into the system until such time as LRMD's credits in the amount of 4,100,000, or in the event the amount of \$976,000 is not fully reimbursed pursuant to the provisions of Section 5, below, then the amount not to exceed \$5,076,000 (\$4,100,000 plus any unreimbursed part of \$976,000) shall have been reduced to \$0.00. To the extent any building permits are pulled in any subdivision filing covered by the above-referenced Development Agreements and recorded on or after the date of the County's approval of this Agreement, the amount of the credit shall be reduced, i.e. debited, by the amount of interim county-wide transportation impact fee or the long-term county-wide transportation impact fee, whichever is in effect as of the date the building permit is pulled. Furthermore, to the extent any cash funds are available in the interim or the long-term county-wide transportation impact fee accounts, Lorson shall be entitled to a cash disbursement therefrom, which cash disbursement shall likewise reduce the credit by the amount of the cash disbursement, and which cash disbursement shall be disbursed according to the priority queue that the County will establish at a later date and subject to the disbursement policies that the County will establish at a later date.

5. To the extent the PPRTA determines to authorize funding for improvements to the intersection of Fontaine and Marksheffel, which improvements will most likely occur over time and in phases, the County shall submit as part of any County funding request for any phase of a PPRTA Priority A project that involves improvements to the intersection of Fontaine and Marksheffel a request to reimburse LRMD \$976,000 for the

value of LRMD-constructed improvements to the intersection of Fontaine and Marksheffel. The County shall make any submittal pursuant to the policies and procedures of the PPRTA, and to the extent the County requires any information from LRMD in order to prepare the submittal in accordance with the policies and procedures of the PPRTA, LRMD shall promptly provide the requested information. This amount represents the amount of value and benefit provided to the intersection that the PPRTA would otherwise have had to construct at the intersection as part of the voter-authorized Priority A project. The County shall only have an obligation to pay the amount if the PPRTA Board approves the line item for the reimbursement. Under no circumstances does this Fourth Amended Development Agreement express or imply that the County is obligated to expend County funds to reimburse Developer for all or part of the \$976,000 of LRMD-constructed improvements to the intersection. To the extent the PPRTA does not approve the County's funding request for all or part of the \$976,000, any unreimbursed part of the \$976,000 shall be added to LRMD's \$4,100,000 credit pursuant to the provisions of Section 4, above.

IN WITNESS WHEREOF, El Paso County, by and through the Board of County Commissioners of El Paso County, Colorado, enters into this Fourth Amended Development Agreement on this _____ day of July 2012.

ATTEST:

BOARD OF COUNTY COMMISSIONERS
OF EL PASO COUNTY, COLORADO

By: _____
County Clerk and Recorder

By: _____
Amy Lathen, Chair

APPROVED AS TO FORM:

OFFICE OF THE COUNTY ATTORNEY
OF EL PASO COUNTY, COLORADO

By: _____

IN WITNESS WHEREOF, Lorson Ranch Metropolitan District enters into this Fourth Amended Development Agreement this ____ day of July 2012.

By: _____

Print Name: Dave Cocolin

Print Title: Lorson Ranch Metropolitan District, President of the Board