

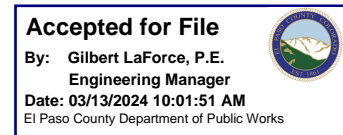


LSC TRANSPORTATION CONSULTANTS, INC.  
2504 East Pikes Peak Avenue, Suite 304  
Colorado Springs, CO 80909  
(719) 633-2868  
FAX (719) 633-5430  
E-mail: [lsc@lsctrans.com](mailto:lsc@lsctrans.com)  
Website: <http://www.lsctrans.com>

Foundation Lutheran Church  
Traffic Impact Study  
EPC PCD File No. SF2321  
(LSC #S234300)  
October 31, 2023

**Traffic Engineer's Statement**

This traffic report and supporting information were prepared under my responsible charge and they comport with the standard of care. So far as is consistent with the standard of care, said report was prepared in general conformance with the criteria established by the County for traffic reports.



**Developer's Statement**

I, the Developer, have read and will comply with all commitments made on my behalf within this report.

*P. D. Besser*

*Nov 1, 2023*  
Date

# Foundation Lutheran Church

## Traffic Impact Study

Prepared for:

Ms. Jennifer Zezlina  
Rocky Mountain Group  
2910 Austin Bluffs Parkway, Suite 100  
Colorado Springs, CO 80918

OCTOBER 31, 2023

---

LSC Transportation Consultants

Prepared by: Jeffrey C. Hodsdon, P.E.

LSC #S234300

EPC PCD File No.: SF2321



**CONTENTS**

REPORT CONTENTS .....4

PREVIOUS TRAFFIC IMPACT STUDIES .....2

STUDY AREA .....2

LAND USE AND ACCESS .....2

    Access for the Foundation Lutheran Church .....3

    Sight Distance .....3

ROADWAY AND TRAFFIC CONDITIONS.....4

    Area Roadways .....4

    Existing Traffic.....4

    Existing Levels of Service.....4

TRIP GENERATION .....5

Weekdays.....5

    Sundays.....6

BACKGROUND TRAFFIC.....6

    Short Term .....6

    Long Term (2043).....6

DIRECTIONAL DISTRIBUTION .....7

SITE-GENERATED TRAFFIC.....7

TOTAL TRAFFIC.....7

PROJECTED LEVELS OF SERVICE .....7

    Towner/Londonderry.....7

PEDESTRIAN FACILITIES.....8

RECOMMENDATIONS.....8

    Auxiliary Lanes .....8

    Intersection Traffic Control .....9

    County Road Impact Fee Program .....9

    Deviations .....9

CONCLUSIONS AND RECOMMENDATIONS .....9

    Trip Generation.....9

    Level of Service .....9

    Enclosures: Table 2.....10

    Figures 1-10 .....10

    Traffic Count Reports.....10

Level of Service Reports.....10



LSC TRANSPORTATION CONSULTANTS, INC.  
2504 East Pikes Peak Avenue, Suite 304  
Colorado Springs, CO 80909  
(719) 633-2868  
FAX (719) 633-5430  
E-mail: [lsc@lsctrans.com](mailto:lsc@lsctrans.com)  
Website: <http://www.lsctrans.com>

October 31, 2023

Ms. Jennifer Zezlina  
Rocky Mountain Group  
2910 Austin Bluffs Parkway, Suite 100  
Colorado Springs, CO 80918

RE: Foundation Lutheran Church  
El Paso County, Colorado  
Traffic Impact Analysis  
EPC PCD File No.: SF2321  
LSC #S234300

Dear Ms. Zezlina:

In response to your request, LSC Transportation Consultants, Inc. has prepared this traffic impact analysis for the proposed Foundation Lutheran Church development in El Paso County, Colorado. As shown in Figure 1, the site is located southwest of the north Londonderry Drive/Towner Avenue intersection in unincorporated El Paso County.

## REPORT CONTENTS

This report is being prepared as part of a submittal to El Paso County. It identifies the traffic impacts of this development. The report contains the following:

- Existing Sunday morning peak hour traffic volumes street conditions.
- Projections of short-term (2024) and long-term (2043) baseline/background traffic volumes.
- The projected average Sunday and Sunday morning peak-hour vehicle-trips to be generated by the church.
- The assignment of the site's projected trips to the adjacent streets and intersections for the short and long term and the resulting total traffic volumes for the short and long term.
- The resulting traffic impacts including level of service analysis at key intersections and average daily traffic volumes on key street sections in the vicinity of the site.
- Recommended improvements.
- Recommended lane configuration for the site access points.

## PREVIOUS TRAFFIC IMPACT STUDIES

LSC completed the following “master” traffic study for Paint Brush Hills (previously Falcon Hills):

- **Falcon Hills [Master] Traffic Impact Study** - April 8, 2004

The following are the most recent traffic studies for Paint Brush Hills (previously Falcon Hills) completed in the past 5-6 years.

- **Paint Brush Hills Filings 13C and 13D** - January 9, 2017
- **D-49 Elementary School** - May 30, 2017.
- **Paint Brush Hills Filing 14** - July 16, 2018
- **Paint Brush Hills Filing 13E** – October 18, 2018

## STUDY AREA

Key approaches at the following offsite intersections have been evaluated for potential inclusion in the study area using criteria in ECM Appendix B.

- Southern Londonderry & Towner Intersection
- Towner and Stapleton Intersection
- Londonderry and Meridian Intersection

The evaluation is included in Appendix A. Calculations are shown in Appendix Table 1. The most recent available weekday peak hour traffic counts have been utilized in the percent impact calculation. Those count sheets are also included in Appendix A (note: the “denominator” volumes have undoubtedly increased since 2018/2020, so the evaluation is conservative). The estimated church weekday traffic (estimated in the table) during the same/corresponding peak period has also been utilized in the calculation.

Based on the calculations, the ECM threshold of ten percent impact is not met. Therefore, the intersections have not been added to the study area. Any improvements that have been built or may be required in the future to accommodate **weekday** AM peak hour traffic, will also be sufficient to accommodate significantly lower Sunday morning peak hour baseline traffic plus site-generated traffic.

## LAND USE AND ACCESS

The proposed Foundation Lutheran Church is located southwest of the north intersection of Londonderry Drive and Towner Avenue. There are existing single-family homes north, west, and south of the site. The Bennett Ranch elementary school is located east of the site.

The proposed church will be 9,730 square feet. The church sanctuary will have 250 seats in the short term and 350 seats in the long term. Currently, one Sunday service is held at 10:45 am at another location. There is the potential for two church services on Sunday morning in the future. These potential future times are unknown at this time. However, other well-established church institutions in the Pikes Peak region, which are holding two Sunday morning services, report scheduled service start times of 9 am and 11am or 9am and 10:30am.

On weekdays, the building will host a preschool which will have a maximum of 80 students. Per the applicant, the preschool parent drop-off and pick-up times will be off-peak from the area schools and general peak traffic times. Therefore, this report focuses on Sunday morning peak hour. The applicant indicates that the expected times and days of the week for the preschool operation are 9am-1pm Monday through Friday.

### **Access for the Foundation Lutheran Church**

Two full-movement access points are proposed. Access to Londonderry Drive is proposed to align with Triborough Trail (about 302 feet west of Towner Avenue and 502 feet east of Beckham Street). Access to Towner Avenue is proposed to align with the existing metro district driveway on the east side of Towner (about 240 feet south of Londonderry Drive). The site plan is shown in Figure 2.

### **Sight Distance**

The required intersection sight distance at the site access driveways is 455 feet based on the posted speed of 35 miles per hour per ECM criteria contained in ECM Table 2-35 in Section 2.4.1.D. The line of sight is available to achieve the required sight distance at the new access points.

- The sight distance to the east along Londonderry from the north access is about 625-650 feet.
- The sight distance to the west along Londonderry from the north access is about 950 feet.
- The sight distance to the south along Towner from the east access is at least 900 feet.
- Regarding the sight distance to the north along Towner from the east access, the sight distance for a design speed of 20 mph is 240 feet (*A Policy on Geometric Design of Highways and Streets 2018, American Association of State Highway and Transportation Officials, 7th Edition p.9-46, Table 9-7*). This is about the same distance looking north from the Towner Access to the Londonderry Intersection to observe a westbound to southbound left turning vehicle (assuming a turning speed of 20 mph).

Site improvements such as structures, solid fences, landscaping, parking areas, monument signs, etc. must not impede lines of sight required for these required sight distances. Note: The existing transformer located along the south side of Londonderry and east of the proposed access location will not impede the line of sight from the proposed access. It is located about 20 feet

back from the roadway. The driver's eye at the access will be only 10 feet back per table 2-35, footnote No. 1.

The required "Minimum Sight Distance Along Roadway" ECM per Table 2-33 is 225 feet for the 35 mph posted speed limit. This prescribed distance would be met for eastbound and westbound traffic on Londonderry Drive and northbound traffic on Towner Avenue approaching the site access points. For southbound traffic approaching the east access, the stopping sight distance on southbound Towner approaching the site access, based on a vehicle speed having completed a turn from Londonderry (about 25 mph), would be 155 feet (*A Policy on Geometric Design of Highways and Streets* 2018, American Association of State Highway and Transportation Officials, 7th Edition p.9-46, Table 9-7). The distance from this point to the access is about 185 feet.

## **ROADWAY AND TRAFFIC CONDITIONS**

### **Area Roadways**

The area roadways in the site's vicinity are shown in Figures 1 and are described below.

- **Londonderry Drive** is a two-lane Urban Residential Collector that currently extends west from Eastonville Road to 2,460 feet west of Towner Avenue and then loops to the south to intersect Towner Avenue again about one-half mile to the south. The posted speed limit adjacent to the site is 35 miles per hour (mph).
- **Towner Avenue** is a 40-foot-wide (paved) Urban Residential Collector street (within Paint Brush Hills) that extends south from Londonderry Drive to just south of Woodmen Hills Drive. The posted speed limit is 35 miles per hour.
- **Triborough Trail** is a north/south local street that extends north from Londonderry Drive to just east of Beckham Street. The posted speed limit is 25 miles per hour.

### **Existing Traffic**

Figure 3 shows the current Sunday morning peak hour traffic volumes at the intersections of Londonderry Drive/Towner Avenue and Londonderry Drive/Triborough Trail. These traffic volumes are based on traffic counts conducted by LSC in September 2023. The traffic count reports are attached.

### **Existing Levels of Service**

Level of service (LOS) is a quantitative measure of the level of congestion or delay at an intersection. Level of service is indicated on a scale from "A" to "F." LOS A represents control delay of less than 10 seconds for unsignalized and signalized intersections. LOS F represents control delay of more than 50 seconds for unsignalized intersections and more than 80 seconds for signalized intersections. Table 1 shows the level of service delay ranges.



Table 1			
Intersection Levels of Service Delay Ranges			
Level of Service	Signalized Intersections		Unsignalized Intersections
	Average Control Delay (seconds per vehicle)	V/C <sup>(1)</sup>	Average Control Delay (seconds per vehicle) <sup>(2)</sup>
A	10.0 sec or less	less than 0.60	10.0 sec or less
B	10.1-20.0 sec	0.60-0.69	10.1-15.0 sec
C	20.1-35.0 sec	0.70-0.79	15.1-25.0 sec
D	35.1-55.0 sec	0.80-0.89	25.1-35.0 sec
E	55.1-80.0 sec	0.90-0.99	35.1-50.0 sec
F	80.1 sec or more	1.00 and greater	50.1 sec or more

(1) Source: *Transportation Research Circular 212*  
 (2) For unsignalized intersections if V/C ratio is greater than 1.0 the level of service is LOS F regardless of the projected average control delay per vehicle.

The intersections of Londonderry Drive and Towner Avenue and Londonderry Drive/Triborough Trail were analyzed to determine the existing levels of service using the unsignalized method of analysis procedures outlined in the *Highway Capacity Manual, 6th Edition* by the Transportation Research Board.

Figure 3 shows the level of service analysis results. As shown on the figure, all movements these intersections are level of service B or better during the Sunday peak hour. The level of service (LOS) reports are attached.

**TRIP GENERATION**

The site-generated vehicle-trips were estimated using the nationally published trip generation rates from *Trip Generation, 11th Edition, 2021* by the Institute of Transportation Engineers (ITE).

Table 2 (attached) shows the trip generation estimate for Foundation Lutheran Church.

**Weekdays**

As shown in Table 2, the church is expected to generate about 401 vehicle-trips on the average weekday, with about half entering and half exiting the site during a 24-hour period. During the morning peak hour, which generally occurs for one hour between 6:30 and 8:30 a.m., about 5 vehicles would enter and 2 vehicles would exit the site. During the afternoon peak hour, which generally occurs for one hour between 4:15 and 6:15 p.m., about 4 vehicles would enter and 6 vehicles would exit the site.

As the preschool is not planned to operate during the typical peak hours or school peak hours, a separate “peak hour of the generator” analysis was run as shown in Table 4. During the preschool AM peak hour, about 33 vehicles would enter and 30 vehicles would exit the site. During the preschool PM peak hour, about 30 vehicles would enter and 35 vehicles would exit the site.

### **Sundays**

A church has the highest trip generation on Sundays. Table 4 shows the trip generation estimate for the church on an average Sunday. As presented in the table, the church is estimated to generate about 306 vehicle-trips on the average Sunday, with about half entering and half exiting the site during a Sunday 24-hour period based on the church square footage of 9,743 square feet.

As mentioned above, ITE trip generation rates have been used for this report. Regarding the Sunday morning peak hour for churches, ITE trip generation rates do not specify the number of Sunday services specifically associated with the data points. However, as both the entering and exiting peak hour trip rates are relatively close in value, this suggests that the rates account for traffic departing a first service and arriving for a second service. The applicant indicates the potential for two services in the future, with both entering and exiting traffic occurring during the same hour. Assuming the potential for two Sunday services, the peak hour would potentially occur between 10 and 11 am with both entering and exiting traffic occurring during the same hour. Note: Churches typically prefer to minimize overlap of the highest flow of traffic departing a first service and highest flow of traffic **arriving** for the second service. This is primarily due to the efficient use of parking spaces, but benefits traffic flow as well. Note: the analysis in this report assumes a worst-case of minimal stagger by using a low peak hour factor in the level of service analysis.

During the Sunday morning peak hour, about 63 vehicles would enter and 66 vehicles would exit the site based on 250 seats proposed in the short term. In the long term, the church will increase to 350 seats. During the peak hour, the church will then have about 88 vehicles entering and 92 vehicles exiting the site. As the peak hour is higher on Sundays, the following analysis is based on the Sunday morning peak hour instead of a typical weekday peak hour(s) or weekday school peak hours.

### **BACKGROUND TRAFFIC**

Background traffic is the traffic estimated to be on the area streets and roadways without consideration of the proposed church development.

#### **Short Term**

Figure 3 shows the existing traffic volumes plus minor adjustments to account for a slightly earlier church peak hour if that were to occur.

#### **Long Term (2043)**

Figure 7 shows the projected background traffic volumes for the long term (2024). These volumes are estimates by LSC and take into account the future development of undeveloped lots to the northwest.

### **DIRECTIONAL DISTRIBUTION**

The directional distribution of the site-generated traffic volumes on the area roadways is an important factor in determining the site's traffic impacts. Figure 4 shows the short-term and long-term directional distribution estimates for the site-generated traffic volumes. The estimates have been based on the following factors: the site's location with respect to nearby communities and neighborhoods and the balance of the Falcon and northeast Colorado Springs area; the site's proposed land use; the site's proposed access points; and the phasing of the existing and future roadway system serving the site.

### **SITE-GENERATED TRAFFIC**

Figure 5 shows the projected short-term and long-term site-generated traffic volumes, respectively. The site-generated traffic volumes were calculated by applying the directional distribution percentages (from Figure 4) to the trip generation estimates from Table 2.

### **TOTAL TRAFFIC**

Figure 6 shows the projected short-term total traffic volumes. The short-term total traffic volumes are the sum of the existing traffic volumes (from Figure 3) plus the short-term site-generated traffic volumes from Figure 5.

Figure 8 shows the projected 2043 total traffic volumes. The 2043 total traffic volumes are the sum of the 2043 background traffic volumes (from Figure 7) plus the long-term site-generated traffic volumes from Figure 5.

### **PROJECTED LEVELS OF SERVICE**

The access point intersections and the intersection of Londonderry/Towner were analyzed to determine the projected levels of service for the background and total traffic volumes based on the unsignalized method of analysis procedures from the *Highway Capacity Manual, 6<sup>th</sup> Edition* by the Transportation Research Board. Figures 3, 6, 7, and 8 show the level of service analysis results. The level of service reports are attached.

#### **Towner/Londonderry**

All movements at the north and south intersections of Towner/Londonderry, Londonderry/Triborough Trail, and the site access intersection on Towner are projected to

operate at LOS A or B during the Sunday morning peak hour based on the projected short-term and 2043 total traffic volumes.

## **PEDESTRIAN FACILITIES**

The adjacent Londonderry Drive and Towner Avenue generally provides sidewalks or gravel trail connections in the area. The signal at Londonderry/Meridian Road provides a pedestrian crossing location to/from Meridian Ranch to the east. The school crossing location just west of Londonderry/Tottenham Court will also provide a good crossing location pedestrian access to/from the church, as will the south leg of the Londonderry/Towner intersection.

The church site plan shows new sidewalk along both Towner and Londonderry, with pedestrian ramps across the site driveways. Please refer to the CDs and Site Development Plan for additional details. The applicant has indicated that additional ped ramps will be provided at the site access points as required by the county.

## **RECOMMENDATIONS**

### **Auxiliary Lanes**

For Urban, Collector streets, with a posted speed limit of 35 mph (40 mph design speed), right and left turn deceleration lanes have required deceleration length of 155 feet plus a 160-foot taper. Left turn lanes are also required to include stacking/vehicle storage length. Note: The ECM allows for the potential use of tangent bay tapers with a minimum taper ratio of 8:1 in constrained locations. The minimum ECM bay taper length would be 96 feet.

- Based on the criteria contained in the *El Paso County Engineering Criteria Manual (ECM)* and the projected 2043 total traffic volumes, the turning volume threshold of 25 vph would be met during the Sunday morning peak hour at the east access to Towner. Although opposing traffic is expected to be light, LSC recommends restriping the center painted median (currently two sets of dual yellow centerline stripes) to accommodate northbound left turns from Towner into the access driveway. A concept for the recommended restriping is shown in Figure 9.
- Based on the criteria contained in the *El Paso County Engineering Criteria Manual (ECM)* and the projected short-term and 2043 total Sunday morning peak hour traffic volumes and the minimum threshold turning volume of 25 vph, no auxiliary turn lanes would be required on Londonderry Drive approaching the north site access. However, review comments have indicated that a left turn would be required. A concept for the recommended restriping is shown in Figure 10.

### **Intersection Traffic Control**

The site access driveways should be controlled with Stop-signs.

### **County Road Impact Fee Program**

- The applicant will be required to participate in the County Road Impact Fee Program.
- No PID option is available for this land use. The up-front, full fee would be \$32,810. This amount is subject to change. Road Impact fees will need to be paid at time of plat recording or at time of building permit.

### **Deviations**

A deviation request for “access to a Collector street” is included with this submittal. The site only has frontage on two Collector streets, with no ability to access a local street. However, the *ECM* criteria does not allow private access to a Collector Street. The access points are proposed to align with an existing public street and an existing driveway. Please refer to the deviation request – a separate submittal document.

## **CONCLUSIONS AND RECOMMENDATIONS**

### **Trip Generation**

- The Foundation Lutheran Church is expected to generate about 401 vehicle-trips on the average weekday, with about half entering and half exiting the site during a 24-hour period. During the morning peak hour about 5 vehicles would enter and 2 vehicles would exit the site. During the afternoon peak hour about 4 vehicles would enter and 6 vehicles would exit the site.
- The peak hours for the preschool, which are anticipated to be off-peak, would result in about 33 vehicles entering and 30 vehicles exiting in the AM peak hour and 30 vehicles entering and 35 vehicles exiting in the PM peak hour.
- On Sunday’s, the church is expected to generate about 306 vehicle-trips with about half entering and half exiting the site during a 24-hour period. In the short-term with 250 seats, about 63 vehicles would enter and 66 vehicles would exit the site. In the long-term with 350 seats, about 88 vehicles would enter and 92 vehicles would exit the site.

### **Level of Service**

All movements at the access points and study area intersections are projected to operate at LOS A or B during the Sunday morning peak hour through 2043.

Please contact me if you have any questions or need further assistance.

Sincerely,

LSC TRANSPORTATION CONSULTANTS, INC.

By: Jeffrey C. Hodsdon, P.E.  
Principal

JCH:jas

Enclosures: Table 2  
Figures 1-10  
Traffic Count Reports  
Level of Service Reports

# Table 2

---

The table area is currently blank.







# Figures 1-9

---





Figure 1  
**Vicinity Map**  
Foundation Lutheran Church (LSC# S234300)

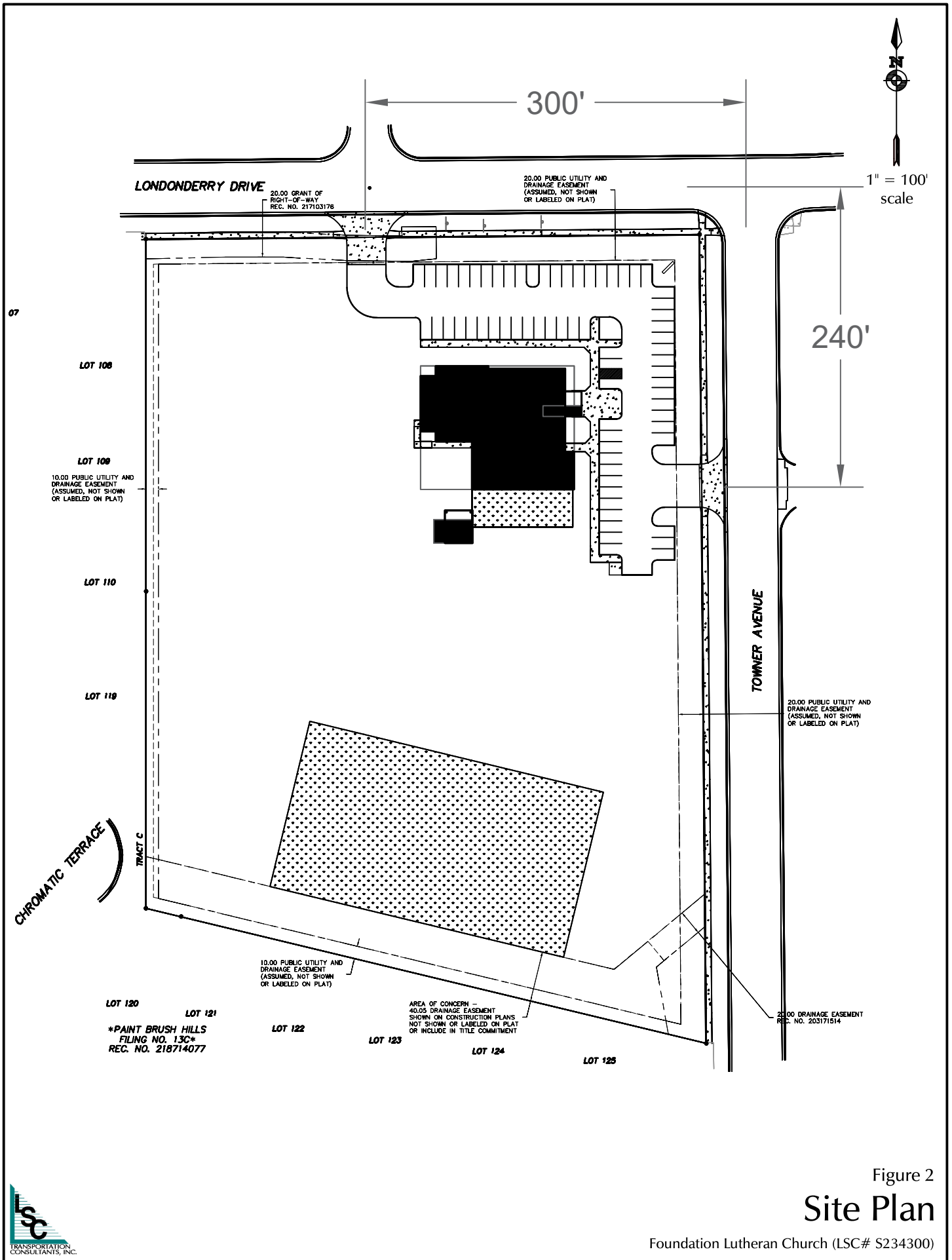


Figure 2  
**Site Plan**

Foundation Lutheran Church (LSC# S234300)



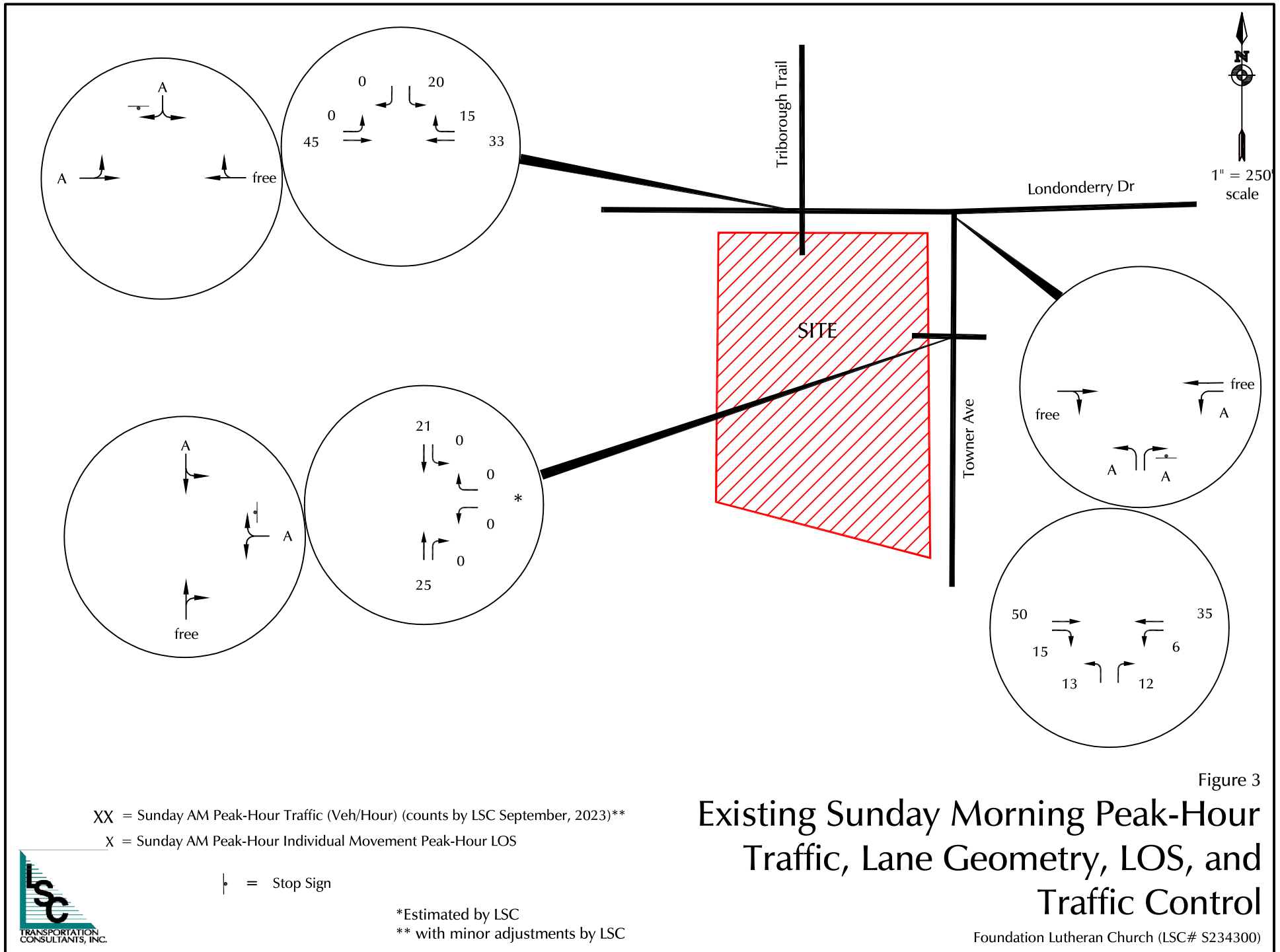
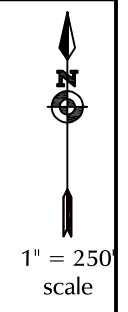
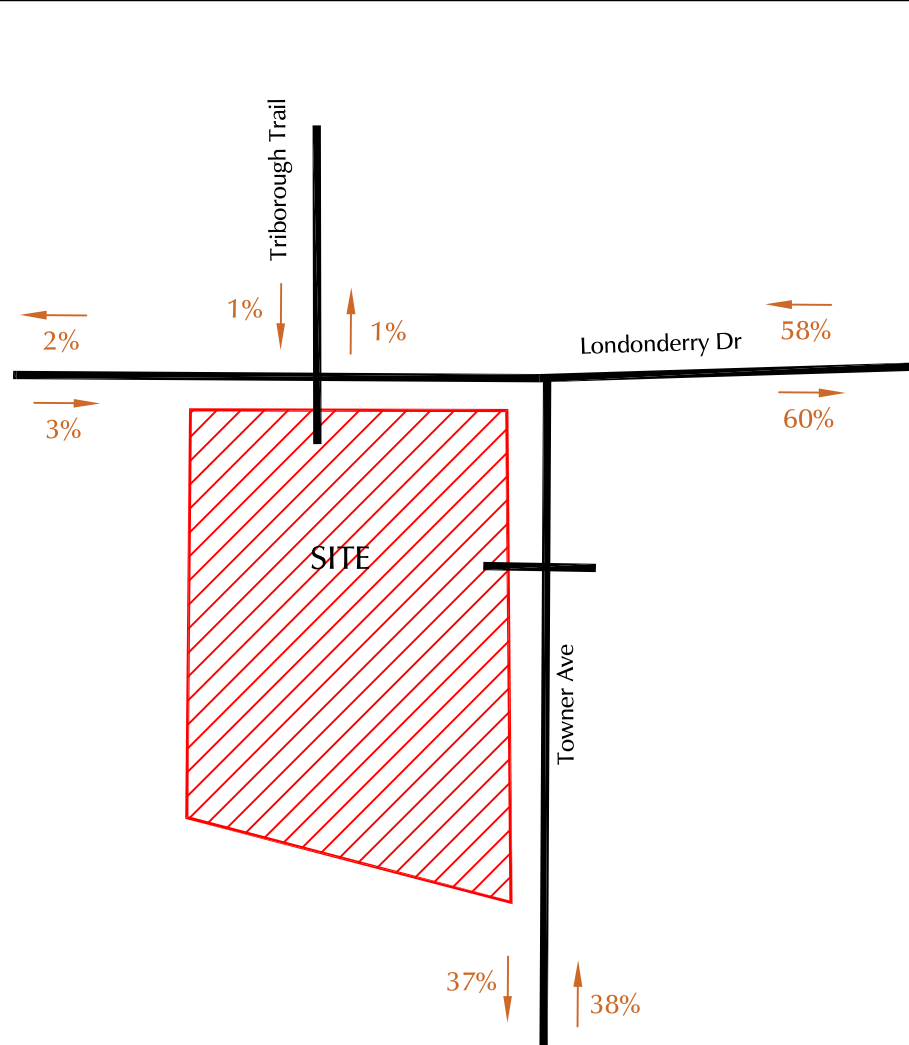


Figure 3  
**Existing Sunday Morning Peak-Hour  
 Traffic, Lane Geometry, LOS, and  
 Traffic Control**



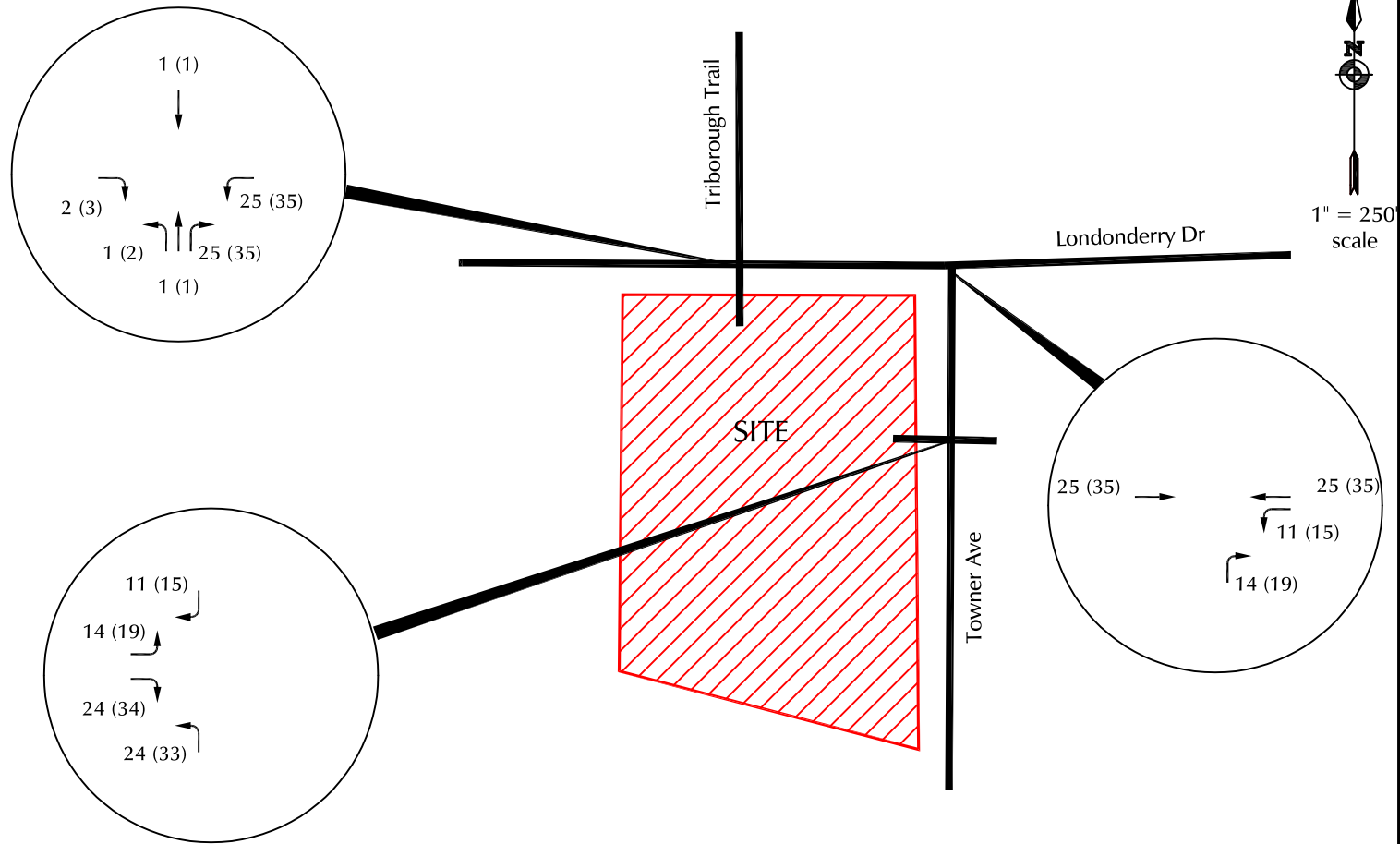


→ XX% = Sunday Morning Peak Hour % Distribution of Site-Generated Trips



Figure 4  
Estimated Directional Distribution

Foundation Lutheran Church (LSC# S234300)



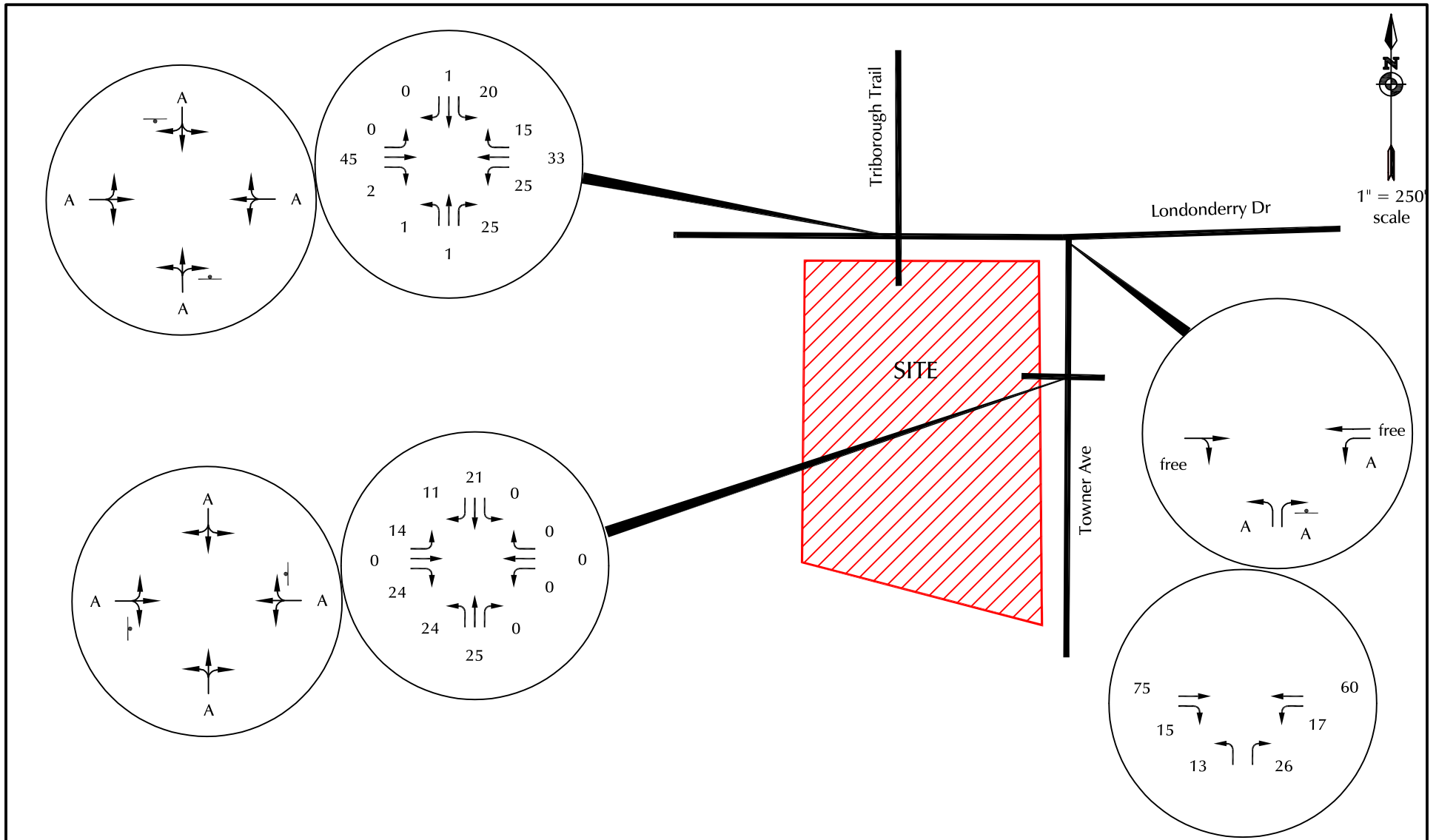
XX (XX) = Short-Term (Long-Term) Sunday Morning Peak-Hour Traffic (Veh/Hour)

## Site-Generated Sunday Morning Peak-Hour Traffic

Figure 5

Foundation Lutheran Church (LSC# S234300)



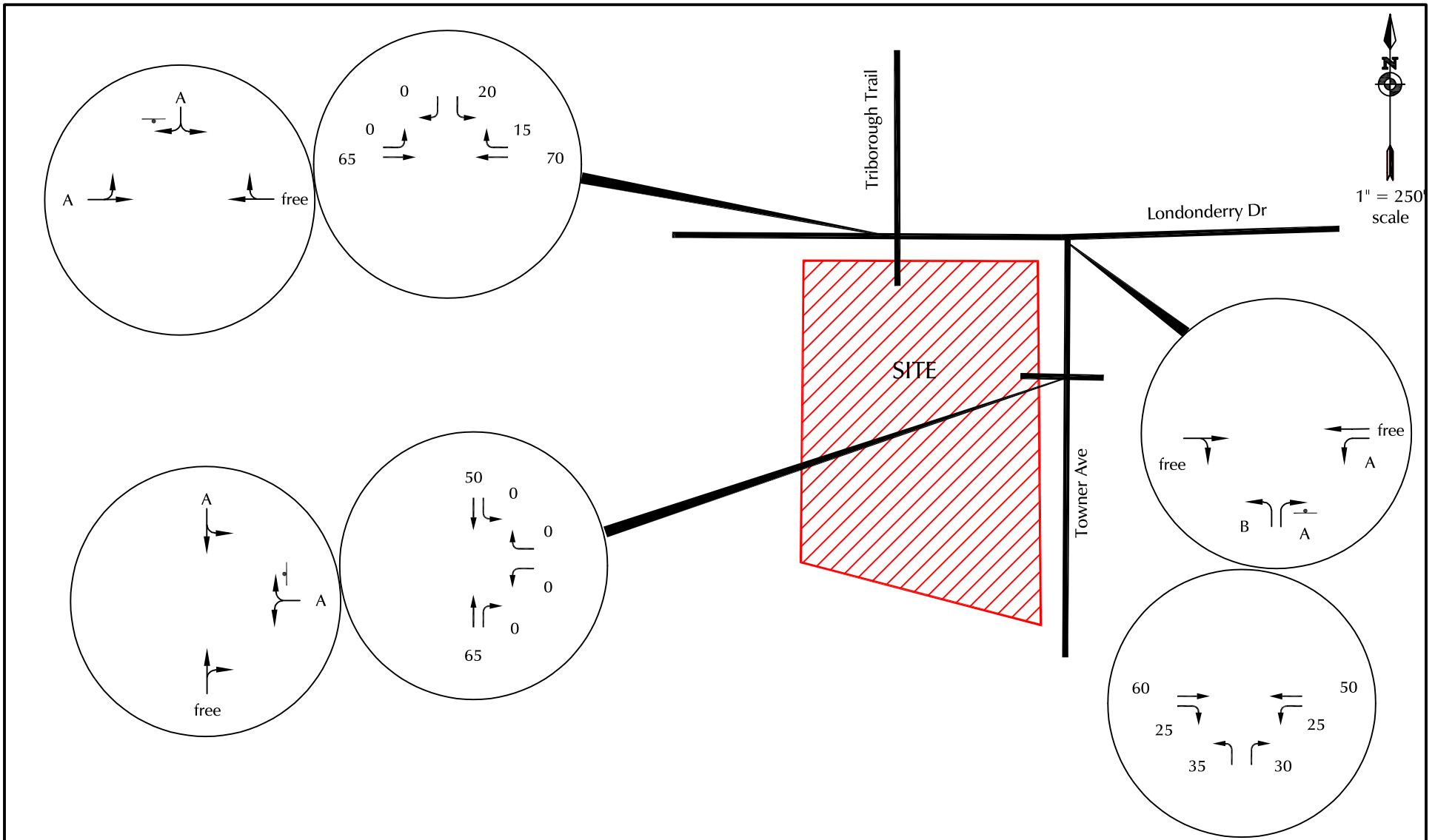


XX = Sunday Morning Peak-Hour Traffic (Veh/Hour)  
 X = Sunday Morning Peak-Hour Individual Movement Peak-Hour LOS

⊥ = Stop Sign

Figure 6  
**Existing plus Site-Generated Sunday Morning Peak-Hour Traffic, Lane Geometry, LOS, and Traffic Control**





XX = Sunday Morning Peak-Hour Traffic (Veh/Hour)  
 X = Sunday Morning Peak-Hour Individual Movement Peak-Hour LOS

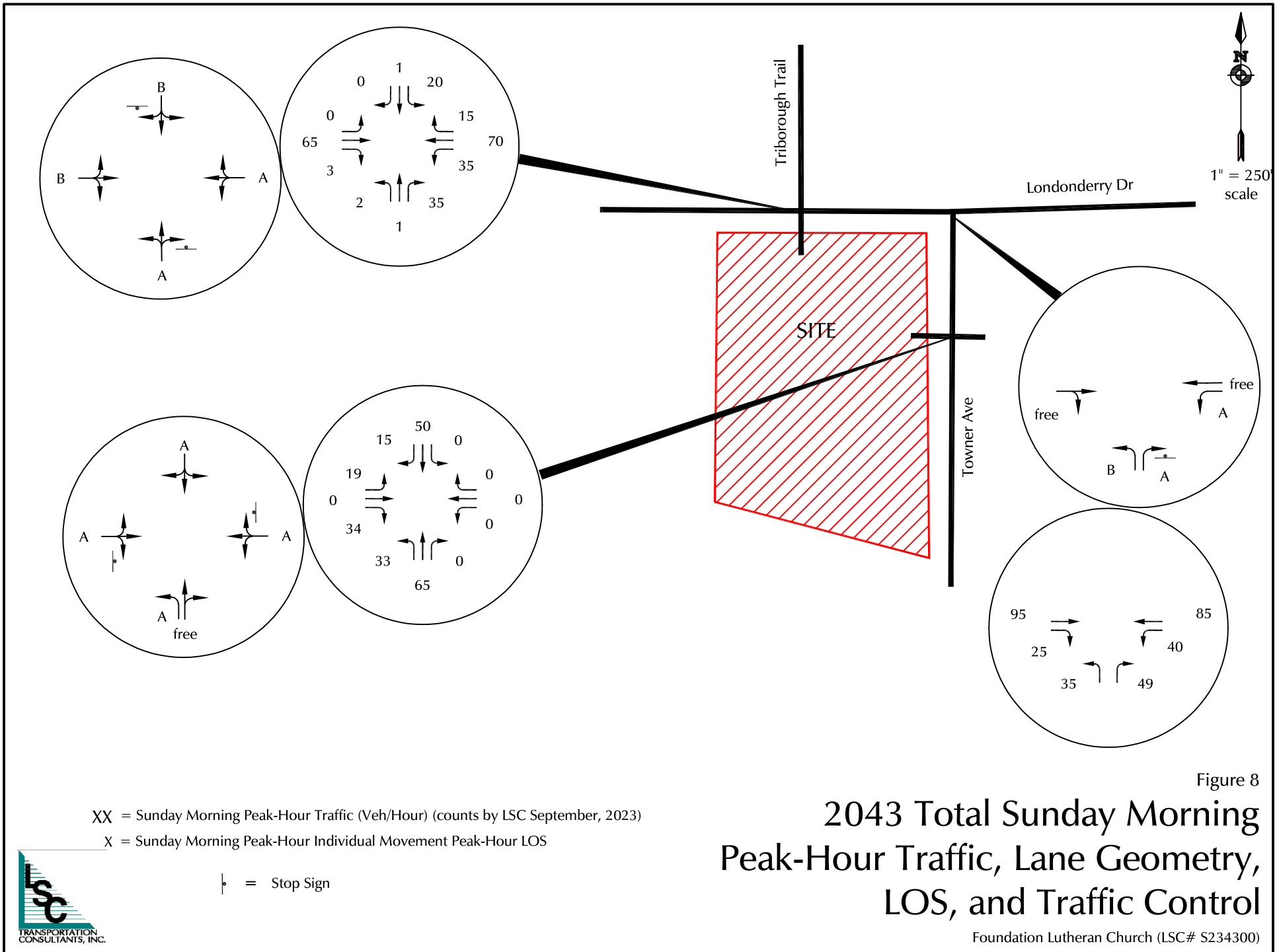
⊥ = Stop Sign

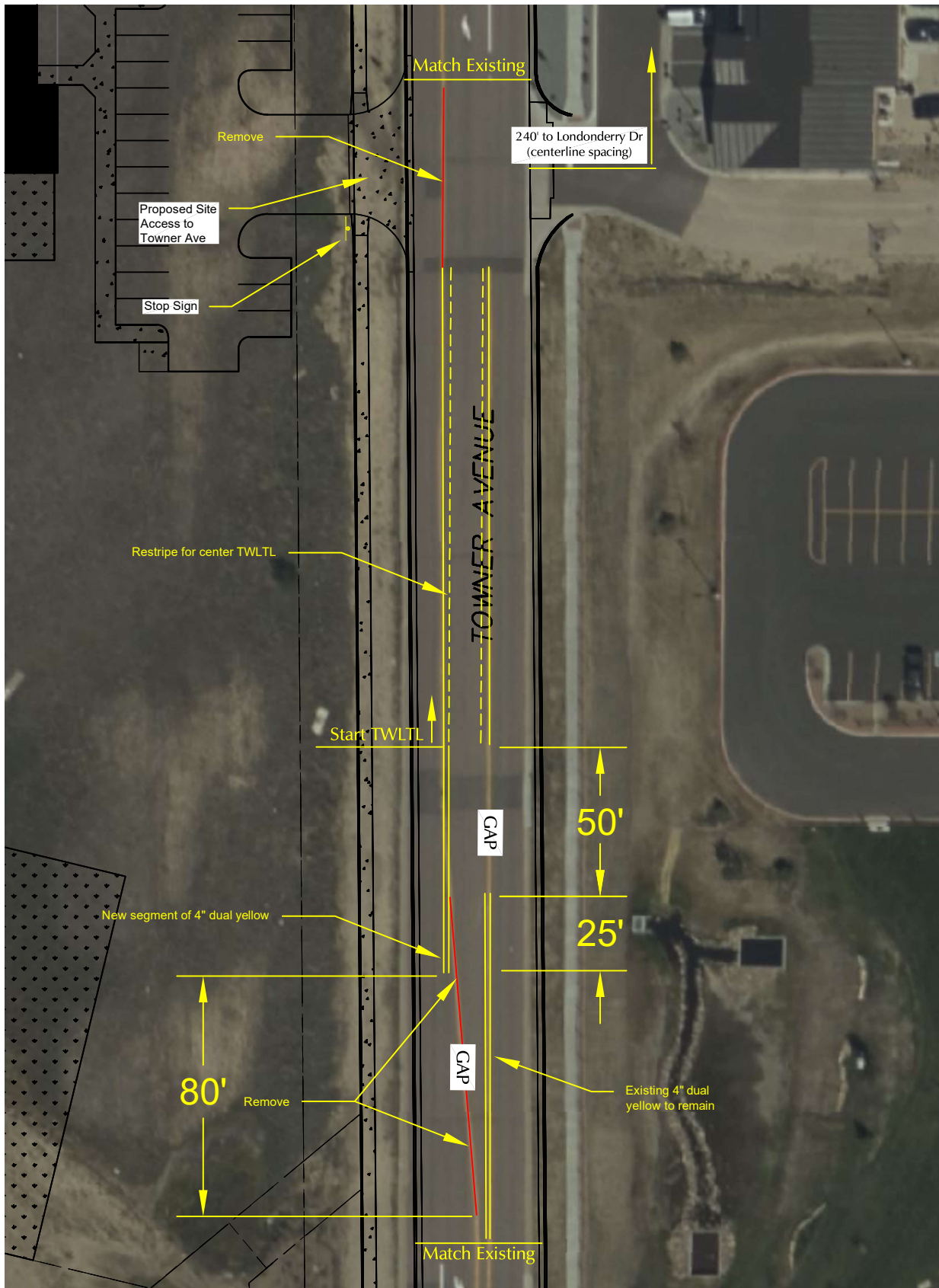


Figure 7  
**2043 Background Sunday  
 Traffic, Lane Geometry, LOS,  
 and Traffic Control**

Foundation Lutheran Church (LSC# S234300)








  
 Approximate  
 Scale  
 1" = 50'

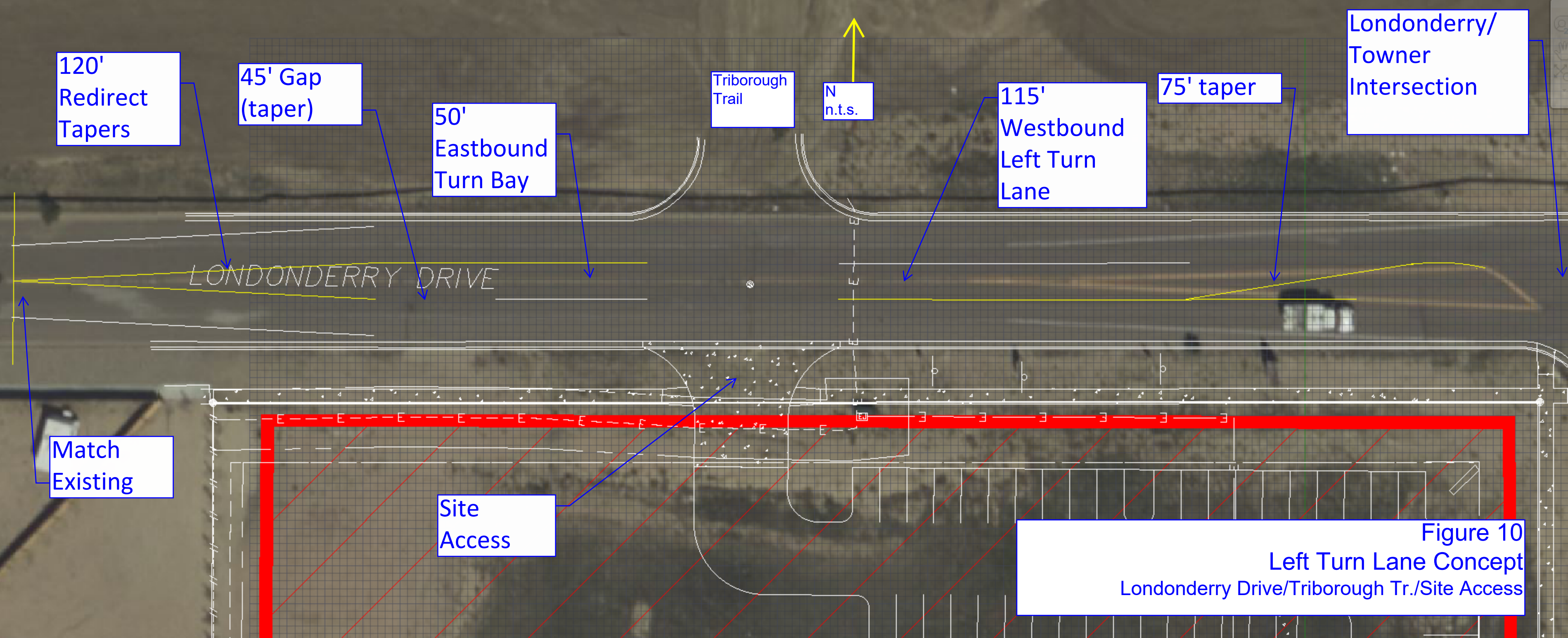
Figure 9

# Proposed Restriping on Towner Ave at the Site Access



Concept only, not for construction.

Foundation Lutheran Church (LSC# S234300)



120'  
Redirect  
Tapers

45' Gap  
(taper)

50'  
Eastbound  
Turn Bay

Triborough  
Trail

N  
n.t.s.

115'  
Westbound  
Left Turn  
Lane

75' taper

Londonderry/  
Towner  
Intersection

LONDONDERRY DRIVE

Match  
Existing

Site  
Access

Figure 10  
Left Turn Lane Concept  
Londonderry Drive/Triborough Tr./Site Access

# Traffic Counts

---



# LSC Transportation Consultants, Inc.

2504 E. Pikes Peak Ave, Suite 304  
 Colorado Springs, CO 80909  
 719-633-2868

File Name : Towner Ave N - Londonderry Dr Post-Service Sun

Site Code : S234300

Start Date : 9/10/2023

Page No : 1

### Groups Printed- Unshifted

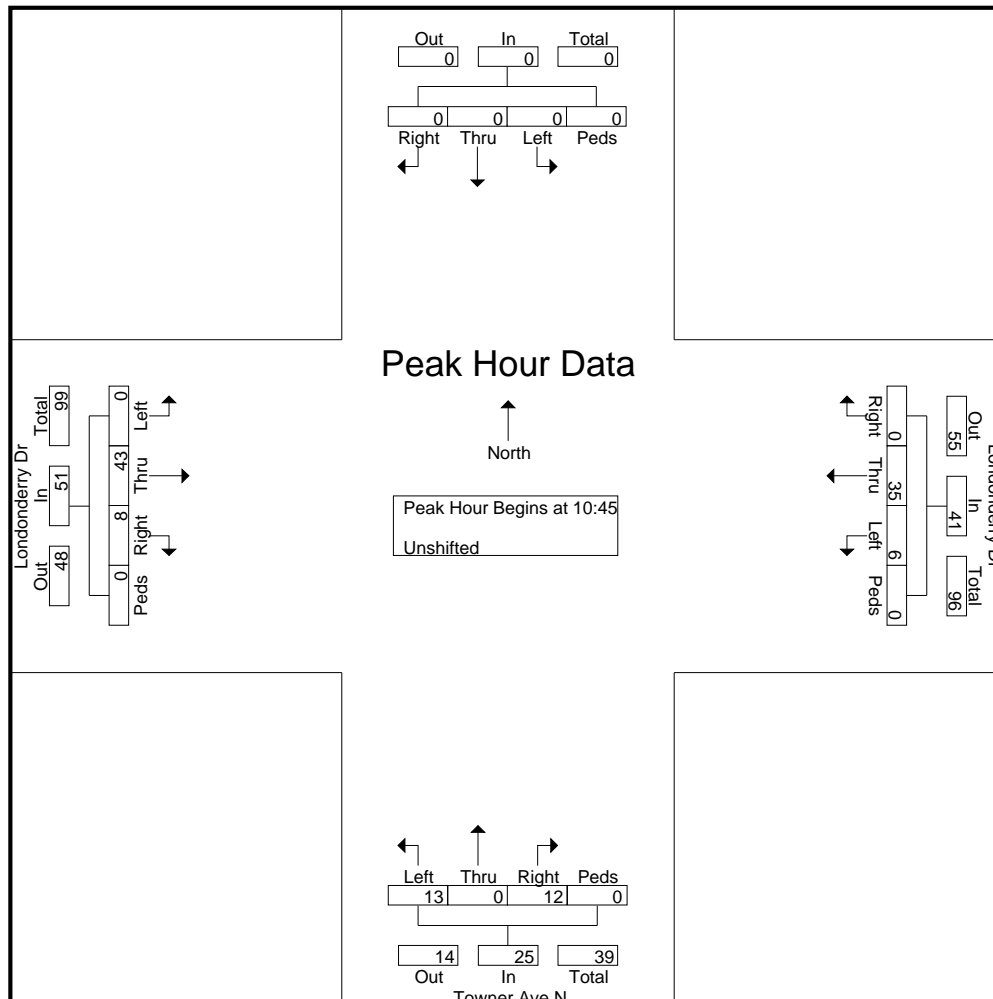
Start Time	Southbound					Londonderry Dr Westbound					Towner Ave N Northbound					Londonderry Dr Eastbound					Int. Total
	Right	Thru	Left	Peds	App. Total	Right	Thru	Left	Peds	App. Total	Right	Thru	Left	Peds	App. Total	Right	Thru	Left	Peds	App. Total	
10:45	0	0	0	0	0	0	3	1	0	4	1	0	2	0	3	1	5	0	0	6	13
10:50	0	0	0	0	0	0	4	0	0	4	1	0	2	0	3	0	1	0	0	1	8
10:55	0	0	0	0	0	0	2	2	0	4	1	0	2	0	3	1	6	0	0	7	14
<b>Total</b>	0	0	0	0	0	0	9	3	0	12	3	0	6	0	9	2	12	0	0	14	35
11:00	0	0	0	0	0	0	2	0	0	2	1	0	0	0	1	2	3	0	0	5	8
11:05	0	0	0	0	0	0	3	1	0	4	0	0	1	0	1	1	2	0	0	3	8
11:10	0	0	0	0	0	0	2	0	0	2	0	0	0	0	0	1	5	0	0	6	8
11:15	0	0	0	0	0	0	1	0	0	1	1	0	2	0	3	1	3	0	0	4	8
11:20	0	0	0	0	0	0	5	0	0	5	0	0	3	0	3	0	3	0	0	3	11
11:25	0	0	0	0	0	0	3	1	0	4	2	0	0	0	2	0	1	0	0	1	7
11:30	0	0	0	0	0	0	2	1	0	3	1	0	0	0	1	1	5	0	0	6	10
11:35	0	0	0	0	0	0	2	0	0	2	3	0	0	0	3	0	4	0	0	4	9
11:40	0	0	0	0	0	0	6	0	0	6	1	0	1	0	2	0	5	0	0	5	13
<b>Grand Total</b>	0	0	0	0	0	0	35	6	0	41	12	0	13	0	25	8	43	0	0	51	117
<b>Apprch %</b>	0	0	0	0	0	0	85.4	14.6	0		48	0	52	0		15.7	84.3	0	0		
<b>Total %</b>	0	0	0	0	0	0	29.9	5.1	0	35	10.3	0	11.1	0	21.4	6.8	36.8	0	0	43.6	

# LSC Transportation Consultants, Inc.

2504 E. Pikes Peak Ave, Suite 304  
 Colorado Springs, CO 80909  
 719-633-2868

File Name : Towner Ave N - Londonderry Dr Post-Service Sun  
 Site Code : S234300  
 Start Date : 9/10/2023  
 Page No : 2

Start Time	Southbound					Londonderry Dr Westbound					Towner Ave N Northbound					Londonderry Dr Eastbound					Int. Total
	Right	Thru	Left	Peds	App. Total	Right	Thru	Left	Peds	App. Total	Right	Thru	Left	Peds	App. Total	Right	Thru	Left	Peds	App. Total	
Peak Hour Analysis From 10:45 to 11:40 - Peak 1 of 1																					
Peak Hour for Entire Intersection Begins at 10:45																					
10:45	0	0	0	0	0	0	3	1	0	4	1	0	2	0	3	1	5	0	0	6	13
10:50	0	0	0	0	0	0	4	0	0	4	1	0	2	0	3	0	1	0	0	1	8
10:55	0	0	0	0	0	0	2	2	0	4	1	0	2	0	3	1	6	0	0	7	14
11:00	0	0	0	0	0	0	2	0	0	2	1	0	0	0	1	2	3	0	0	5	8
11:05	0	0	0	0	0	0	3	1	0	4	0	0	1	0	1	1	2	0	0	3	8
11:10	0	0	0	0	0	0	2	0	0	2	0	0	0	0	0	1	5	0	0	6	8
11:15	0	0	0	0	0	0	1	0	0	1	1	0	2	0	3	1	3	0	0	4	8
11:20	0	0	0	0	0	0	5	0	0	5	0	0	3	0	3	0	3	0	0	3	11
11:25	0	0	0	0	0	0	3	1	0	4	2	0	0	0	2	0	1	0	0	1	7
11:30	0	0	0	0	0	0	2	1	0	3	1	0	0	0	1	1	5	0	0	6	10
11:35	0	0	0	0	0	0	2	0	0	2	3	0	0	0	3	0	4	0	0	4	9
11:40	0	0	0	0	0	0	6	0	0	6	1	0	1	0	2	0	5	0	0	5	13
Total Volume	0	0	0	0	0	0	35	6	0	41	12	0	13	0	25	8	43	0	0	51	117
% App. Total	0	0	0	0	0	0	85.4	14.6	0		48	0	52	0		15.7	84.3	0	0		
PHF	.000	.000	.000	.000	.000	.000	.486	.250	.000	.569	.333	.000	.361	.000	.694	.333	.597	.000	.000	.607	.696



# LSC Transportation Consultants, Inc.

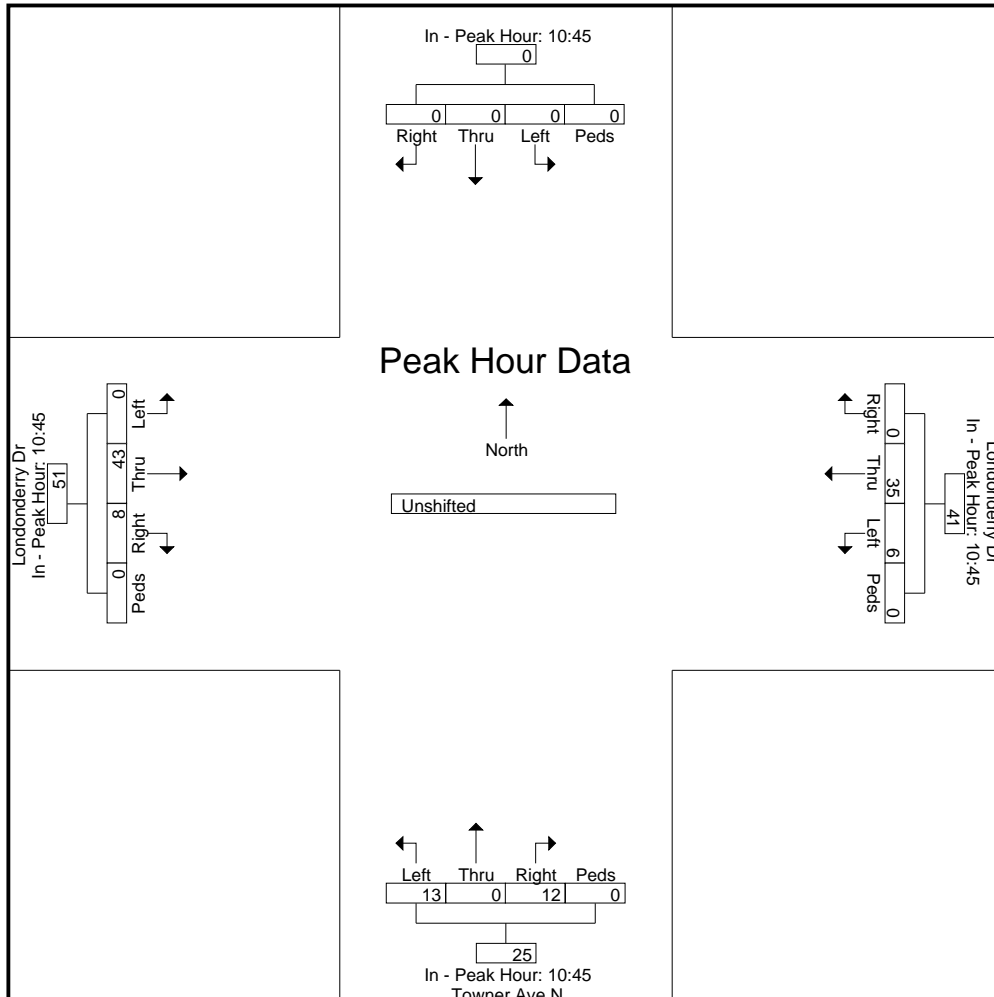
2504 E. Pikes Peak Ave, Suite 304  
 Colorado Springs, CO 80909  
 719-633-2868

File Name : Towner Ave N - Londonderry Dr Post-Service Sun  
 Site Code : S234300  
 Start Date : 9/10/2023  
 Page No : 3

Start Time	Southbound					Londonderry Dr Westbound					Towner Ave N Northbound					Londonderry Dr Eastbound					Int. Total
	Right	Thru	Left	Peds	App. Total	Right	Thru	Left	Peds	App. Total	Right	Thru	Left	Peds	App. Total	Right	Thru	Left	Peds	App. Total	

Peak Hour Analysis From 10:45 to 11:40 - Peak 1 of 1  
 Peak Hour for Each Approach Begins at:

	10:45					10:45					10:45					10:45				
+0 mins.	0	0	0	0	0	0	3	1	0	4	1	0	2	0	3	1	5	0	0	6
+5 mins.	0	0	0	0	0	0	4	0	0	4	1	0	2	0	3	0	1	0	0	1
+10 mins.	0	0	0	0	0	0	2	2	0	4	1	0	2	0	3	1	6	0	0	7
+15 mins.	0	0	0	0	0	0	2	0	0	2	1	0	0	0	1	2	3	0	0	5
+20 mins.	0	0	0	0	0	0	3	1	0	4	0	0	1	0	1	1	2	0	0	3
+25 mins.	0	0	0	0	0	0	2	0	0	2	0	0	0	0	0	1	5	0	0	6
+30 mins.	0	0	0	0	0	0	1	0	0	1	1	0	2	0	3	1	3	0	0	4
+35 mins.	0	0	0	0	0	0	5	0	0	5	0	0	3	0	3	0	3	0	0	3
+40 mins.	0	0	0	0	0	0	3	1	0	4	2	0	0	0	2	0	1	0	0	1
+45 mins.	0	0	0	0	0	0	2	1	0	3	1	0	0	0	1	1	5	0	0	6
+50 mins.	0	0	0	0	0	0	2	0	0	2	3	0	0	0	3	0	4	0	0	4
+55 mins.	0	0	0	0	0	0	6	0	0	6	1	0	1	0	2	0	5	0	0	5
Total Volume	0	0	0	0	0	0	35	6	0	41	12	0	13	0	25	8	43	0	0	51
% App. Total	0	0	0	0	0	0	85.4	14.6	0	41	48	0	52	0	51	15.7	84.3	0	0	51
PHF	.000	.000	.000	.000	.000	.000	.486	.250	.000	.569	.333	.000	.361	.000	.694	.333	.597	.000	.000	.607



# LSC Transportation Consultants, Inc.

2504 E. Pikes Peak Ave, Suite 304  
 Colorado Springs, CO 80909  
 719-633-2868

File Name : Towner Ave N - Londonderry Dr Pre-Service Sun

Site Code : S234300

Start Date : 9/10/2023

Page No : 1

### Groups Printed- Unshifted

Start Time	Southbound					Londonderry Dr Westbound					Towner Dr N Northbound					Londonderry Dr Eastbound					Int. Total
	Right	Thru	Left	Peds	App. Total	Right	Thru	Left	Peds	App. Total	Right	Thru	Left	Peds	App. Total	Right	Thru	Left	Peds	App. Total	
09:15	0	0	0	0	0	0	0	1	0	1	0	1	0	0	1	1	0	0	0	1	3
09:20	0	0	0	0	0	0	1	0	0	1	2	0	1	0	3	0	4	0	0	4	8
09:25	0	0	0	0	0	0	5	0	0	5	0	0	2	0	2	0	1	0	0	1	8
09:30	0	0	0	0	0	0	4	0	0	4	0	0	0	0	0	0	6	0	0	6	10
09:35	0	0	0	0	0	0	1	1	0	2	0	0	1	0	1	1	2	0	0	3	6
09:40	0	0	0	0	0	0	4	0	0	4	1	0	0	0	1	0	4	0	0	4	9
09:45	0	0	0	0	0	0	1	2	0	3	0	0	1	0	1	1	2	0	0	3	7
09:50	0	0	0	0	0	0	3	1	0	4	2	0	1	0	3	1	5	0	0	6	13
09:55	0	0	0	0	0	0	4	0	0	4	4	0	0	0	4	4	3	0	0	7	15
<b>Total</b>	0	0	0	0	0	0	23	5	0	28	9	1	6	0	16	8	27	0	0	35	79
10:00	0	0	0	0	0	0	3	0	0	3	1	0	0	0	1	0	8	0	0	8	12
10:05	0	0	0	0	0	0	1	1	0	2	1	0	0	0	1	1	4	0	0	5	8
10:10	0	0	0	0	0	0	1	0	0	1	1	0	0	0	1	2	6	0	0	8	10
Grand Total	0	0	0	0	0	0	28	6	0	34	12	1	6	0	19	11	45	0	0	56	109
Apprch %	0	0	0	0	0	0	82.4	17.6	0		63.2	5.3	31.6	0		19.6	80.4	0	0		
Total %	0	0	0	0	0	0	25.7	5.5	0	31.2	11	0.9	5.5	0	17.4	10.1	41.3	0	0	51.4	



# LSC Transportation Consultants, Inc.

2504 E. Pikes Peak Ave, Suite 304  
 Colorado Springs, CO 80909  
 719-633-2868

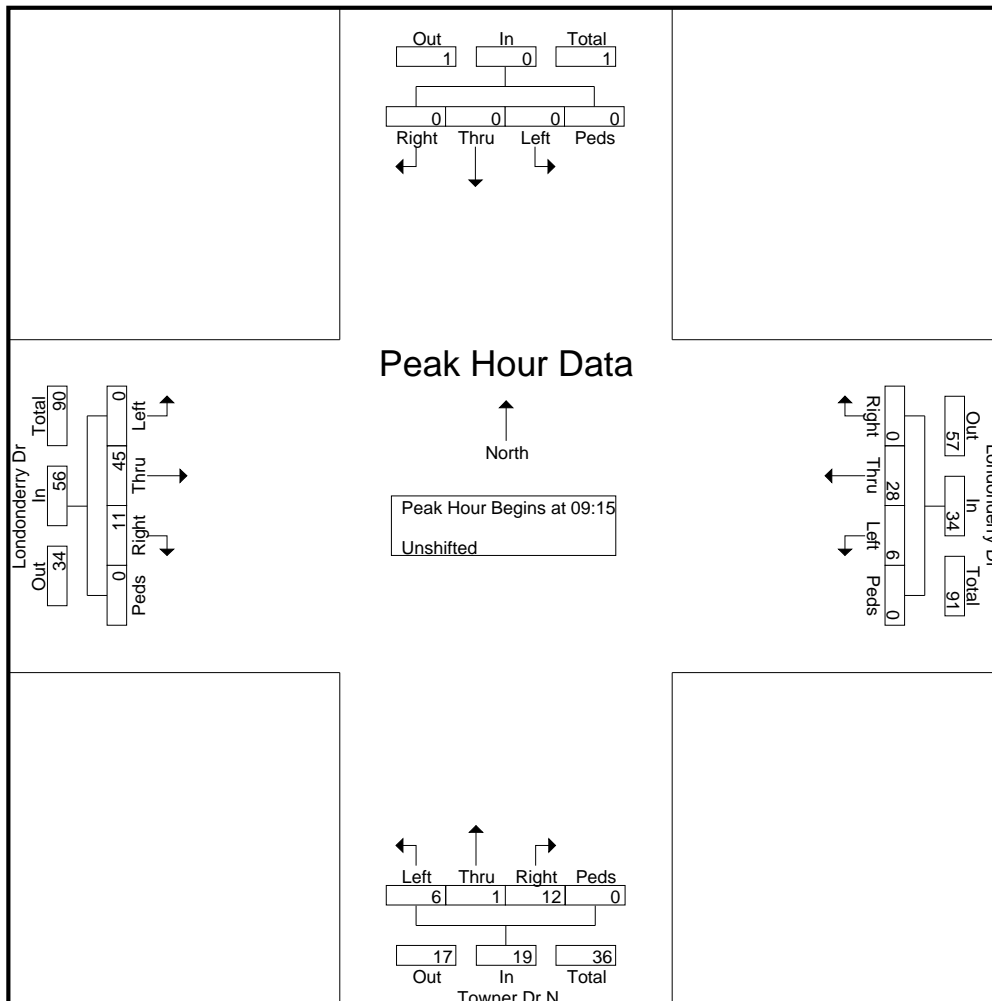
File Name : Towner Ave N - Londonderry Dr Pre-Service Sun

Site Code : S234300

Start Date : 9/10/2023

Page No : 2

Start Time	Southbound					Londonderry Dr Westbound					Towner Dr N Northbound					Londonderry Dr Eastbound					Int. Total
	Right	Thru	Left	Peds	App. Total	Right	Thru	Left	Peds	App. Total	Right	Thru	Left	Peds	App. Total	Right	Thru	Left	Peds	App. Total	
Peak Hour Analysis From 09:15 to 10:10 - Peak 1 of 1																					
Peak Hour for Entire Intersection Begins at 09:15																					
09:15	0	0	0	0	0	0	0	1	0	1	0	1	0	0	1	1	0	0	0	1	3
09:20	0	0	0	0	0	0	1	0	0	1	2	0	1	0	3	0	4	0	0	4	8
09:25	0	0	0	0	0	0	5	0	0	5	0	0	2	0	2	0	1	0	0	1	8
09:30	0	0	0	0	0	0	4	0	0	4	0	0	0	0	0	0	6	0	0	6	10
09:35	0	0	0	0	0	0	1	1	0	2	0	0	1	0	1	1	2	0	0	3	6
09:40	0	0	0	0	0	0	4	0	0	4	1	0	0	0	1	0	4	0	0	4	9
09:45	0	0	0	0	0	0	1	2	0	3	0	0	1	0	1	1	2	0	0	3	7
09:50	0	0	0	0	0	0	3	1	0	4	2	0	1	0	3	1	5	0	0	6	13
09:55	0	0	0	0	0	0	4	0	0	4	4	0	0	0	4	4	3	0	0	7	15
10:00	0	0	0	0	0	0	3	0	0	3	1	0	0	0	1	0	8	0	0	8	12
10:05	0	0	0	0	0	0	1	1	0	2	1	0	0	0	1	1	4	0	0	5	8
10:10	0	0	0	0	0	0	1	0	0	1	1	0	0	0	1	2	6	0	0	8	10
Total Volume	0	0	0	0	0	0	28	6	0	34	12	1	6	0	19	11	45	0	0	56	109
% App. Total	0	0	0	0	0	0	82.4	17.6	0		63.2	5.3	31.6	0		19.6	80.4	0	0		
PHF	.000	.000	.000	.000	.000	.000	.467	.250	.000	.567	.250	.083	.250	.000	.396	.229	.469	.000	.000	.583	.606



# LSC Transportation Consultants, Inc.

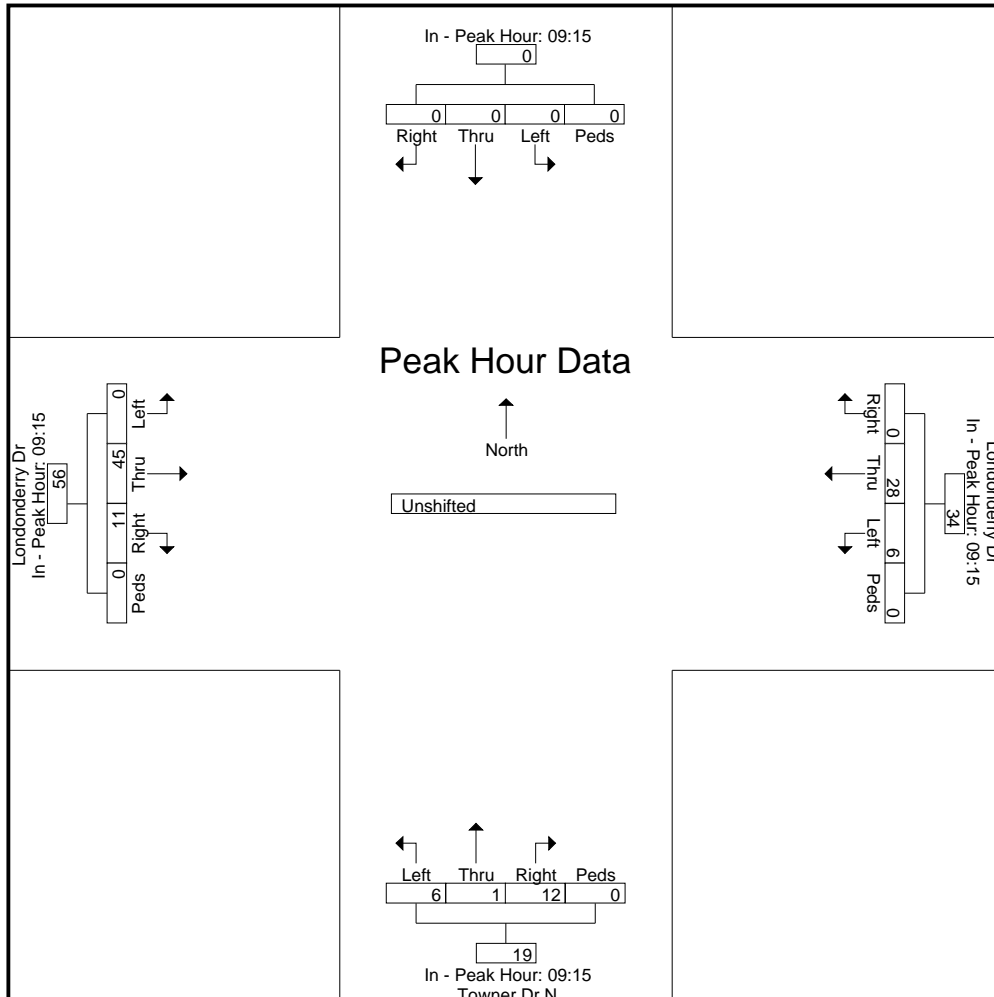
2504 E. Pikes Peak Ave, Suite 304  
 Colorado Springs, CO 80909  
 719-633-2868

File Name : Towner Ave N - Londonderry Dr Pre-Service Sun  
 Site Code : S234300  
 Start Date : 9/10/2023  
 Page No : 3

Start Time	Southbound					Londonderry Dr Westbound					Towner Dr N Northbound					Londonderry Dr Eastbound					Int. Total
	Right	Thru	Left	Peds	App. Total	Right	Thru	Left	Peds	App. Total	Right	Thru	Left	Peds	App. Total	Right	Thru	Left	Peds	App. Total	

Peak Hour Analysis From 09:15 to 10:10 - Peak 1 of 1  
 Peak Hour for Each Approach Begins at:

	09:15					09:15					09:15					09:15				
+0 mins.	0	0	0	0	0	0	0	1	0	1	0	1	0	0	1	1	0	0	0	1
+5 mins.	0	0	0	0	0	0	1	0	0	1	2	0	1	0	3	0	4	0	0	4
+10 mins.	0	0	0	0	0	0	5	0	0	5	0	0	2	0	2	0	1	0	0	1
+15 mins.	0	0	0	0	0	0	4	0	0	4	0	0	0	0	0	0	6	0	0	6
+20 mins.	0	0	0	0	0	0	1	1	0	2	0	0	1	0	1	1	2	0	0	3
+25 mins.	0	0	0	0	0	0	4	0	0	4	1	0	0	0	1	0	4	0	0	4
+30 mins.	0	0	0	0	0	0	1	2	0	3	0	0	1	0	1	1	2	0	0	3
+35 mins.	0	0	0	0	0	0	3	1	0	4	2	0	1	0	3	1	5	0	0	6
+40 mins.	0	0	0	0	0	0	4	0	0	4	4	0	0	0	4	4	3	0	0	7
+45 mins.	0	0	0	0	0	0	3	0	0	3	1	0	0	0	1	0	8	0	0	8
+50 mins.	0	0	0	0	0	0	1	1	0	2	1	0	0	0	1	1	4	0	0	5
+55 mins.	0	0	0	0	0	0	1	0	0	1	1	0	0	0	1	2	6	0	0	8
Total Volume	0	0	0	0	0	0	28	6	0	34	12	1	6	0	19	11	45	0	0	56
% App. Total	0	0	0	0	0	0	82.4	17.6	0	34	63.2	5.3	31.6	0	19	19.6	80.4	0	0	56
PHF	.000	.000	.000	.000	.000	.000	.467	.250	.000	.567	.250	.083	.250	.000	.396	.229	.469	.000	.000	.583





# LSC Transportation Consultants, Inc.

2504 E. Pikes Peak Ave, Suite 304  
 Colorado Springs, CO 80909  
 719-633-2868

File Name : Triborough Trl - Londonderry Dr Post Service Sun

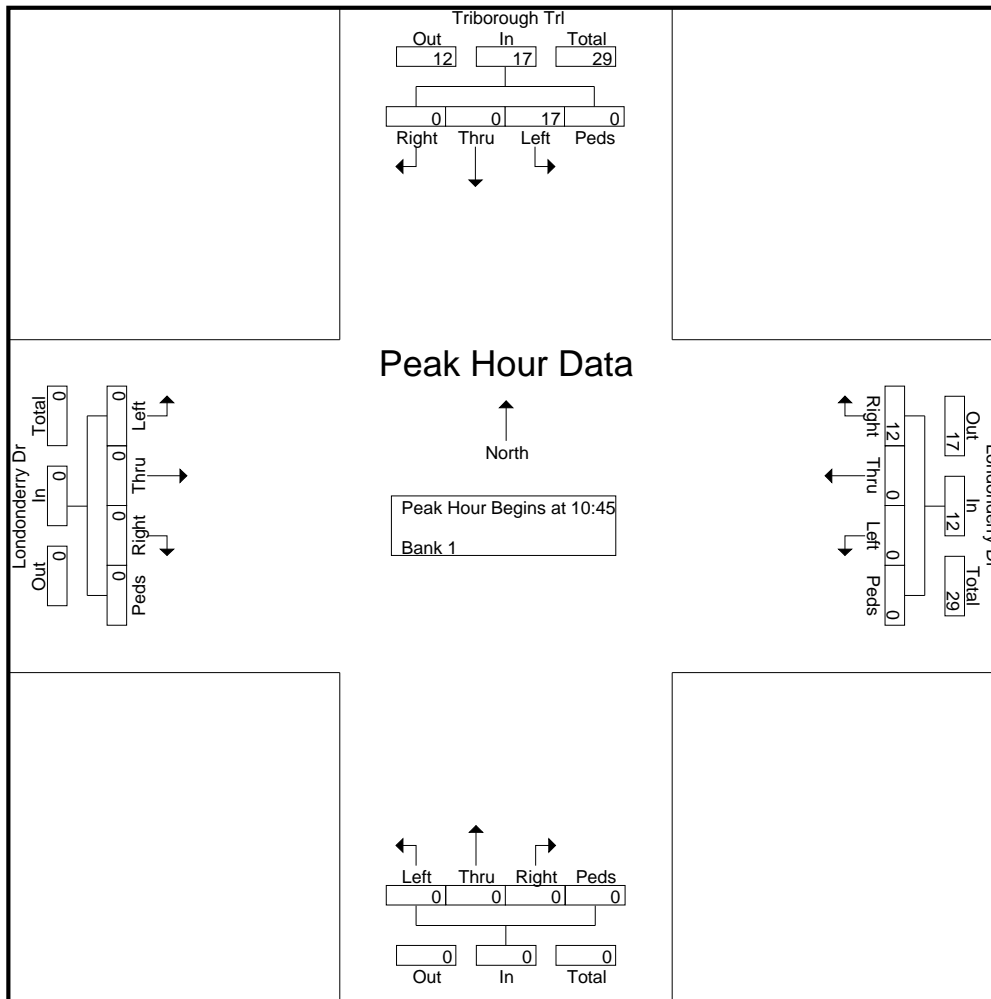
Site Code : S234300

Start Date : 9/10/2023

Page No : 2

Note: Includes Left and Right Turning Movements Only. Thru movements shown in the report reflect volume balancing with the count at the Londonderry/Towner intersection.

Start Time	Triborough Trl Southbound					Londonderry Dr Westbound					Northbound					Londonderry Dr Eastbound					Int. Total	
	Right	Thru	Left	Peds	App. Total	Right	Thru	Left	Peds	App. Total	Right	Thru	Left	Peds	App. Total	Right	Thru	Left	Peds	App. Total		
Peak Hour Analysis From 10:45 to 11:40 - Peak 1 of 1																						
Peak Hour for Entire Intersection Begins at 10:45																						
10:45	0	0	1	0	1	1	0	0	0	1	0	0	0	0	0	0	0	0	0	0	0	2
10:50	0	0	0	0	0	3	0	0	0	3	0	0	0	0	0	0	0	0	0	0	0	3
10:55	0	0	3	0	3	1	0	0	0	1	0	0	0	0	0	0	0	0	0	0	0	4
11:00	0	0	3	0	3	1	0	0	0	1	0	0	0	0	0	0	0	0	0	0	0	4
11:05	0	0	2	0	2	1	0	0	0	1	0	0	0	0	0	0	0	0	0	0	0	3
11:10	0	0	3	0	3	0	0	0	0	0	0	0	0	0	0	0	0	0	0	0	0	3
11:15	0	0	0	0	0	2	0	0	0	2	0	0	0	0	0	0	0	0	0	0	0	2
11:20	0	0	0	0	0	0	0	0	0	0	0	0	0	0	0	0	0	0	0	0	0	0
11:25	0	0	1	0	1	1	0	0	0	1	0	0	0	0	0	0	0	0	0	0	0	2
11:30	0	0	3	0	3	1	0	0	0	1	0	0	0	0	0	0	0	0	0	0	0	4
11:35	0	0	0	0	0	0	0	0	0	0	0	0	0	0	0	0	0	0	0	0	0	0
11:40	0	0	1	0	1	1	0	0	0	1	0	0	0	0	0	0	0	0	0	0	0	2
Total Volume	0	0	17	0	17	12	0	0	0	12	0	0	0	0	0	0	0	0	0	0	0	29
% App. Total	0	0	100	0		100	0	0	0		0	0	0	0		0	0	0	0			
PHF	.000	.000	.472	.000	.472	.333	.000	.000	.000	.333	.000	.000	.000	.000	.000	.000	.000	.000	.000	.000	.604	



# LSC Transportation Consultants, Inc.

2504 E. Pikes Peak Ave, Suite 304  
 Colorado Springs, CO 80909  
 719-633-2868

File Name : Triborough Trl - Londonderry Dr Post Service Sun

Site Code : S234300

Start Date : 9/10/2023

Page No : 3

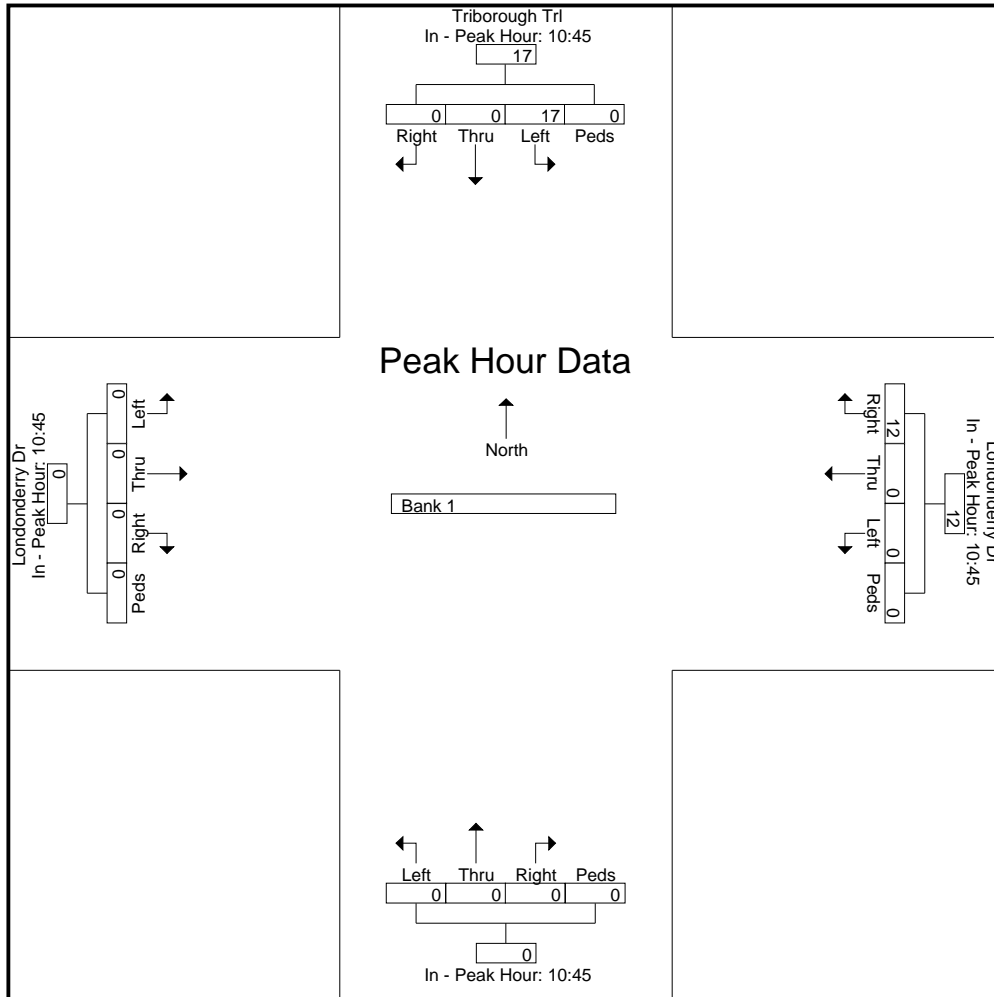
Note: Includes Left and Right Turning Movements Only. Thru movements shown in the report reflect volume balancing with the count at the Londonderry/Towner intersection.

Start Time	Triborough Trl Southbound					Londonderry Dr Westbound					Northbound					Londonderry Dr Eastbound					Int. Total
	Right	Thru	Left	Peds	App. Total	Right	Thru	Left	Peds	App. Total	Right	Thru	Left	Peds	App. Total	Right	Thru	Left	Peds	App. Total	

Peak Hour Analysis From 10:45 to 11:40 - Peak 1 of 1

Peak Hour for Each Approach Begins at:

	10:45					10:45					10:45					10:45									
+0 mins.	0	0	1	0	1	1	0	0	0	1	0	0	0	0	0	0	0	0	0	0	0	0	0	0	0
+5 mins.	0	0	0	0	0	3	0	0	0	3	0	0	0	0	0	0	0	0	0	0	0	0	0	0	0
+10 mins.	0	0	3	0	3	1	0	0	0	1	0	0	0	0	0	0	0	0	0	0	0	0	0	0	0
+15 mins.	0	0	3	0	3	1	0	0	0	1	0	0	0	0	0	0	0	0	0	0	0	0	0	0	0
+20 mins.	0	0	2	0	2	1	0	0	0	1	0	0	0	0	0	0	0	0	0	0	0	0	0	0	0
+25 mins.	0	0	3	0	3	0	0	0	0	0	0	0	0	0	0	0	0	0	0	0	0	0	0	0	0
+30 mins.	0	0	0	0	0	2	0	0	0	2	0	0	0	0	0	0	0	0	0	0	0	0	0	0	0
+35 mins.	0	0	0	0	0	0	0	0	0	0	0	0	0	0	0	0	0	0	0	0	0	0	0	0	0
+40 mins.	0	0	1	0	1	1	0	0	0	1	0	0	0	0	0	0	0	0	0	0	0	0	0	0	0
+45 mins.	0	0	3	0	3	1	0	0	0	1	0	0	0	0	0	0	0	0	0	0	0	0	0	0	0
+50 mins.	0	0	0	0	0	0	0	0	0	0	0	0	0	0	0	0	0	0	0	0	0	0	0	0	0
+55 mins.	0	0	1	0	1	1	0	0	0	1	0	0	0	0	0	0	0	0	0	0	0	0	0	0	0
Total Volume	0	0	17	0	17	12	0	0	0	12	0	0	0	0	0	0	0	0	0	0	0	0	0	0	0
% App. Total	0	0	100	0		100	0	0	0		0	0	0	0		0	0	0	0		0	0	0	0	
PHF	.000	.000	.472	.000	.472	.333	.000	.000	.000	.333	.000	.000	.000	.000	.000	.000	.000	.000	.000	.000	.000	.000	.000	.000	.000



# LSC Transportation Consultants, Inc.

2504 E. Pikes Peak Ave, Suite 304  
 Colorado Springs, CO 80909  
 719-633-2868

File Name : Triborough Trl - Londonderry Dr Pre-Service Sun

Site Code : S234300

Start Date : 9/10/2023

Page No : 1

Note: Includes Left and Right Turning Movements Only. Thru movements shown in the report reflect volume balancing with the count at the Londonderry/Towner intersection.

## Groups Printed- Bank 1

Start Time	Triborough Trl Southbound					Londonderry Dr Westbound					Northbound					Londonderry Dr Eastbound					Int. Total
	Right	Thru	Left	Peds	App. Total	Right	Thru	Left	Peds	App. Total	Right	Thru	Left	Peds	App. Total	Right	Thru	Left	Peds	App. Total	
09:15	0	0	1	0	1	0	0	0	0	0	0	0	0	0	0	0	0	0	0	0	0
09:20	0	0	1	0	1	0	0	0	0	0	0	0	0	0	0	0	0	0	0	0	0
09:25	0	0	2	0	2	1	0	0	0	1	0	0	0	0	0	0	0	0	0	0	0
09:30	0	0	1	0	1	1	0	0	0	1	0	0	0	0	0	0	0	0	0	0	0
09:35	0	0	2	0	2	1	0	0	0	1	0	0	0	0	0	0	0	0	0	0	0
09:40	0	0	1	0	1	0	0	0	0	0	0	0	0	0	0	0	0	0	0	0	0
09:45	0	0	0	0	0	1	0	0	0	1	0	0	0	0	0	0	0	0	0	0	0
09:50	0	0	2	0	2	1	0	0	0	1	0	0	0	0	0	0	0	0	0	0	0
09:55	0	0	2	0	2	0	0	0	0	0	0	0	0	0	0	0	0	0	0	0	0
<b>Total</b>	0	0	12	0	12	5	0	0	0	5	0	0	0	0	0	0	0	0	0	0	17
10:00	0	0	0	0	0	2	0	0	0	2	0	0	0	0	0	0	0	0	0	0	2
*** BREAK ***																					
10:10	0	0	2	0	2	0	0	0	0	0	0	0	0	0	0	0	0	0	0	0	2
Grand Total	0	0	14	0	14	7	0	0	0	7	0	0	0	0	0	0	0	0	0	0	21
Apprch %	0	0	100	0		100	0	0	0		0	0	0	0		0	0	0	0		
Total %	0	0	66.7	0	66.7	33.3	0	0	0	33.3	0	0	0	0	0	0	0	0	0	0	

# LSC Transportation Consultants, Inc.

2504 E. Pikes Peak Ave, Suite 304  
 Colorado Springs, CO 80909  
 719-633-2868

File Name : Triborough Trl - Londonderry Dr Pre-Service Sun

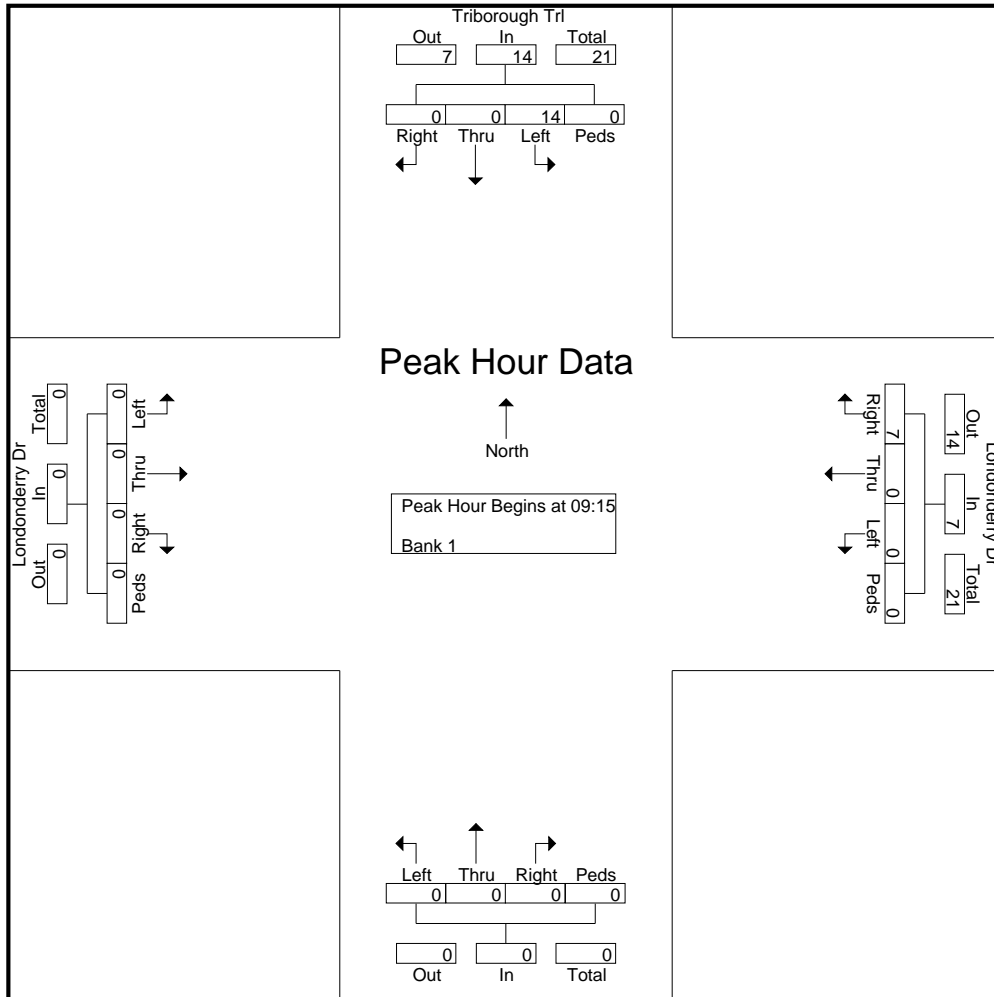
Site Code : S234300

Start Date : 9/10/2023

Page No : 2

Note: Includes Left and Right Turning Movements Only. Thru movements shown in the report reflect volume balancing with the count at the Londonderry/Towner intersection.

Start Time	Triborough Trl Southbound					Londonderry Dr Westbound					Northbound					Londonderry Dr Eastbound					Int. Total	
	Right	Thru	Left	Peds	App. Total	Right	Thru	Left	Peds	App. Total	Right	Thru	Left	Peds	App. Total	Right	Thru	Left	Peds	App. Total		
Peak Hour Analysis From 09:15 to 10:10 - Peak 1 of 1																						
Peak Hour for Entire Intersection Begins at 09:15																						
09:15	0	0	1	0	1	0	0	0	0	0	0	0	0	0	0	0	0	0	0	0	0	1
09:20	0	0	1	0	1	0	0	0	0	0	0	0	0	0	0	0	0	0	0	0	0	1
09:25	0	0	2	0	2	1	0	0	0	1	0	0	0	0	0	0	0	0	0	0	0	3
09:30	0	0	1	0	1	1	0	0	0	1	0	0	0	0	0	0	0	0	0	0	0	2
09:35	0	0	2	0	2	1	0	0	0	1	0	0	0	0	0	0	0	0	0	0	0	3
09:40	0	0	1	0	1	0	0	0	0	0	0	0	0	0	0	0	0	0	0	0	0	1
09:45	0	0	0	0	0	1	0	0	0	1	0	0	0	0	0	0	0	0	0	0	0	1
09:50	0	0	2	0	2	1	0	0	0	1	0	0	0	0	0	0	0	0	0	0	0	3
09:55	0	0	2	0	2	0	0	0	0	0	0	0	0	0	0	0	0	0	0	0	0	2
10:00	0	0	0	0	0	2	0	0	0	2	0	0	0	0	0	0	0	0	0	0	0	2
10:05	0	0	0	0	0	0	0	0	0	0	0	0	0	0	0	0	0	0	0	0	0	0
10:10	0	0	2	0	2	0	0	0	0	0	0	0	0	0	0	0	0	0	0	0	0	2
Total Volume	0	0	14	0	14	7	0	0	0	7	0	0	0	0	0	0	0	0	0	0	0	21
% App. Total	0	0	100	0		100	0	0	0		0	0	0	0		0	0	0	0		0	
PHF	.000	.000	.583	.000	.583	.292	.000	.000	.000	.292	.000	.000	.000	.000	.000	.000	.000	.000	.000	.000	.000	.583



# LSC Transportation Consultants, Inc.

2504 E. Pikes Peak Ave, Suite 304  
 Colorado Springs, CO 80909  
 719-633-2868

File Name : Triborough Trl - Londonderry Dr Pre-Service Sun

Site Code : S234300

Start Date : 9/10/2023

Page No : 3

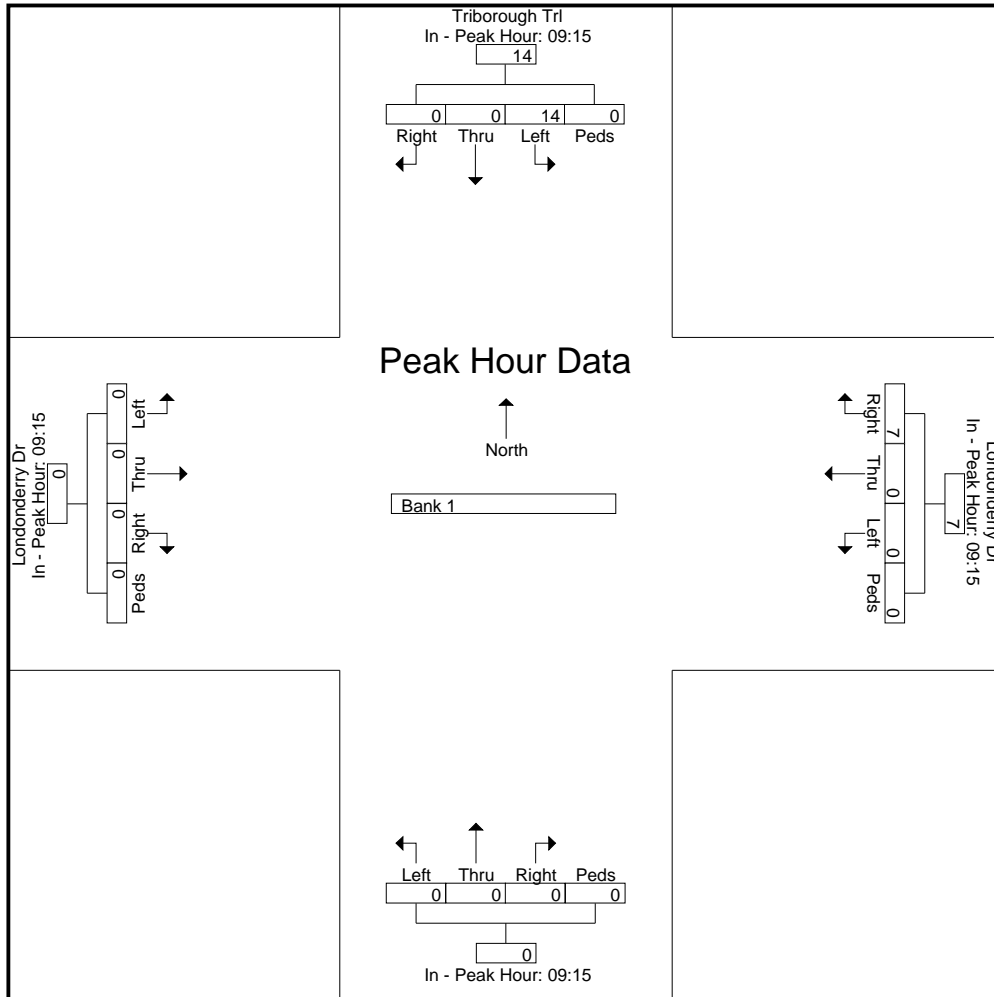
Note: Includes Left and Right Turning Movements Only. Thru movements shown in the report reflect volume balancing with the count at the Londonderry/Towner intersection.

Start Time	Triborough Trl Southbound					Londonderry Dr Westbound					Northbound					Londonderry Dr Eastbound					Int. Total
	Right	Thru	Left	Peds	App. Total	Right	Thru	Left	Peds	App. Total	Right	Thru	Left	Peds	App. Total	Right	Thru	Left	Peds	App. Total	

Peak Hour Analysis From 09:15 to 10:10 - Peak 1 of 1

Peak Hour for Each Approach Begins at:

	09:15					09:15					09:15					09:15									
+0 mins.	0	0	1	0	1	0	0	0	0	0	0	0	0	0	0	0	0	0	0	0	0	0	0	0	0
+5 mins.	0	0	1	0	1	0	0	0	0	0	0	0	0	0	0	0	0	0	0	0	0	0	0	0	0
+10 mins.	0	0	2	0	2	1	0	0	0	1	0	0	0	0	0	0	0	0	0	0	0	0	0	0	0
+15 mins.	0	0	1	0	1	1	0	0	0	1	0	0	0	0	0	0	0	0	0	0	0	0	0	0	0
+20 mins.	0	0	2	0	2	1	0	0	0	1	0	0	0	0	0	0	0	0	0	0	0	0	0	0	0
+25 mins.	0	0	1	0	1	0	0	0	0	0	0	0	0	0	0	0	0	0	0	0	0	0	0	0	0
+30 mins.	0	0	0	0	0	1	0	0	0	1	0	0	0	0	0	0	0	0	0	0	0	0	0	0	0
+35 mins.	0	0	2	0	2	1	0	0	0	1	0	0	0	0	0	0	0	0	0	0	0	0	0	0	0
+40 mins.	0	0	2	0	2	0	0	0	0	0	0	0	0	0	0	0	0	0	0	0	0	0	0	0	0
+45 mins.	0	0	0	0	0	2	0	0	0	2	0	0	0	0	0	0	0	0	0	0	0	0	0	0	0
+50 mins.	0	0	0	0	0	0	0	0	0	0	0	0	0	0	0	0	0	0	0	0	0	0	0	0	0
+55 mins.	0	0	2	0	2	0	0	0	0	0	0	0	0	0	0	0	0	0	0	0	0	0	0	0	0
Total Volume	0	0	14	0	14	7	0	0	0	7	0	0	0	0	0	0	0	0	0	0	0	0	0	0	0
% App. Total	0	0	100	0		100	0	0	0		0	0	0	0		0	0	0	0		0	0	0	0	
PHF	.000	.000	.583	.000	.583	.292	.000	.000	.000	.292	.000	.000	.000	.000	.000	.000	.000	.000	.000	.000	.000	.000	.000	.000	.000





# Levels of Service

---



Intersection						
Int Delay, s/veh	2.1					
Movement	EBT	EBR	WBL	WBT	NBL	NBR
Lane Configurations						
Traffic Vol, veh/h	50	15	6	35	13	12
Future Vol, veh/h	50	15	6	35	13	12
Conflicting Peds, #/hr	0	0	0	0	0	0
Sign Control	Free	Free	Free	Free	Stop	Stop
RT Channelized	-	None	-	None	-	None
Storage Length	-	-	0	-	0	0
Veh in Median Storage, #	0	-	-	0	0	-
Grade, %	0	-	-	0	0	-
Peak Hour Factor	78	78	78	78	75	75
Heavy Vehicles, %	0	0	0	0	0	0
Mvmt Flow	64	19	8	45	17	16

Major/Minor	Major1	Major2	Minor1		
Conflicting Flow All	0	0	83	0	135 74
Stage 1	-	-	-	-	74 -
Stage 2	-	-	-	-	61 -
Critical Hdwy	-	-	4.1	-	6.4 6.2
Critical Hdwy Stg 1	-	-	-	-	5.4 -
Critical Hdwy Stg 2	-	-	-	-	5.4 -
Follow-up Hdwy	-	-	2.2	-	3.5 3.3
Pot Cap-1 Maneuver	-	-	1527	-	863 993
Stage 1	-	-	-	-	954 -
Stage 2	-	-	-	-	967 -
Platoon blocked, %	-	-	-	-	-
Mov Cap-1 Maneuver	-	-	1527	-	859 993
Mov Cap-2 Maneuver	-	-	-	-	859 -
Stage 1	-	-	-	-	954 -
Stage 2	-	-	-	-	962 -

Approach	EB	WB	NB
HCM Control Delay, s	0	1.1	9
HCM LOS			A

Minor Lane/Major Mvmt	NBLn1	NBLn2	EBT	EBR	WBL	WBT
Capacity (veh/h)	859	993	-	-	1527	-
HCM Lane V/C Ratio	0.02	0.016	-	-	0.005	-
HCM Control Delay (s)	9.3	8.7	-	-	7.4	-
HCM Lane LOS	A	A	-	-	A	-
HCM 95th %tile Q(veh)	0.1	0	-	-	0	-

Intersection						
Int Delay, s/veh	1.7					
Movement	EBL	EBT	WBT	WBR	SBL	SBR
Lane Configurations		↶	↷		↶	
Traffic Vol, veh/h	0	45	33	15	20	0
Future Vol, veh/h	0	45	33	15	20	0
Conflicting Peds, #/hr	0	0	0	0	0	0
Sign Control	Free	Free	Free	Free	Stop	Stop
RT Channelized	-	None	-	None	-	None
Storage Length	-	-	-	-	0	-
Veh in Median Storage, #	-	0	0	-	0	-
Grade, %	-	0	0	-	0	-
Peak Hour Factor	78	78	78	78	75	75
Heavy Vehicles, %	0	0	0	0	0	0
Mvmt Flow	0	58	42	19	27	0

Major/Minor	Major1	Major2	Minor2		
Conflicting Flow All	61	0	-	0	110 52
Stage 1	-	-	-	-	52 -
Stage 2	-	-	-	-	58 -
Critical Hdwy	4.1	-	-	-	6.4 6.2
Critical Hdwy Stg 1	-	-	-	-	5.4 -
Critical Hdwy Stg 2	-	-	-	-	5.4 -
Follow-up Hdwy	2.2	-	-	-	3.5 3.3
Pot Cap-1 Maneuver	1555	-	-	-	892 1021
Stage 1	-	-	-	-	976 -
Stage 2	-	-	-	-	970 -
Platoon blocked, %		-	-	-	
Mov Cap-1 Maneuver	1555	-	-	-	892 1021
Mov Cap-2 Maneuver	-	-	-	-	892 -
Stage 1	-	-	-	-	976 -
Stage 2	-	-	-	-	970 -

Approach	EB	WB	SB
HCM Control Delay, s	0	0	9.2
HCM LOS			A

Minor Lane/Major Mvmt	EBL	EBT	WBT	WBR	SBLn1
Capacity (veh/h)	1555	-	-	-	892
HCM Lane V/C Ratio	-	-	-	-	0.03
HCM Control Delay (s)	0	-	-	-	9.2
HCM Lane LOS	A	-	-	-	A
HCM 95th %tile Q(veh)	0	-	-	-	0.1

Intersection						
Int Delay, s/veh	0					
Movement	WBL	WBR	NBT	NBR	SBL	SBT
Lane Configurations						
Traffic Vol, veh/h	0	0	25	0	0	21
Future Vol, veh/h	0	0	25	0	0	21
Conflicting Peds, #/hr	0	0	0	0	0	0
Sign Control	Stop	Stop	Free	Free	Free	Free
RT Channelized	-	None	-	None	-	None
Storage Length	0	-	-	-	-	-
Veh in Median Storage, #	0	-	0	-	-	0
Grade, %	0	-	0	-	-	0
Peak Hour Factor	75	75	75	75	75	75
Heavy Vehicles, %	0	0	0	0	0	0
Mvmt Flow	0	0	33	0	0	28

Major/Minor	Minor1	Major1	Major2			
Conflicting Flow All	61	33	0	0	33	0
Stage 1	33	-	-	-	-	-
Stage 2	28	-	-	-	-	-
Critical Hdwy	6.4	6.2	-	-	4.1	-
Critical Hdwy Stg 1	5.4	-	-	-	-	-
Critical Hdwy Stg 2	5.4	-	-	-	-	-
Follow-up Hdwy	3.5	3.3	-	-	2.2	-
Pot Cap-1 Maneuver	950	1046	-	-	1592	-
Stage 1	995	-	-	-	-	-
Stage 2	1000	-	-	-	-	-
Platoon blocked, %			-	-	-	-
Mov Cap-1 Maneuver	950	1046	-	-	1592	-
Mov Cap-2 Maneuver	950	-	-	-	-	-
Stage 1	995	-	-	-	-	-
Stage 2	1000	-	-	-	-	-

Approach	WB	NB	SB
HCM Control Delay, s	0	0	0
HCM LOS	A		

Minor Lane/Major Mvmt	NBT	NBRWBLn1	SBL	SBT
Capacity (veh/h)	-	-	-	1592
HCM Lane V/C Ratio	-	-	-	-
HCM Control Delay (s)	-	-	0	0
HCM Lane LOS	-	-	A	A
HCM 95th %tile Q(veh)	-	-	-	0

Intersection						
Int Delay, s/veh	2.2					
Movement	EBT	EBR	WBL	WBT	NBL	NBR
Lane Configurations	↔		↔	↑	↔	↔
Traffic Vol, veh/h	75	15	17	60	13	26
Future Vol, veh/h	75	15	17	60	13	26
Conflicting Peds, #/hr	0	0	0	0	0	0
Sign Control	Free	Free	Free	Free	Stop	Stop
RT Channelized	-	None	-	None	-	None
Storage Length	-	-	0	-	0	0
Veh in Median Storage, #	0	-	-	0	0	-
Grade, %	0	-	-	0	0	-
Peak Hour Factor	60	60	60	60	75	75
Heavy Vehicles, %	0	0	0	0	0	0
Mvmt Flow	125	25	28	100	17	35

Major/Minor	Major1	Major2	Minor1		
Conflicting Flow All	0	0	150	0	294
Stage 1	-	-	-	-	138
Stage 2	-	-	-	-	156
Critical Hdwy	-	-	4.1	-	6.4
Critical Hdwy Stg 1	-	-	-	-	5.4
Critical Hdwy Stg 2	-	-	-	-	5.4
Follow-up Hdwy	-	-	2.2	-	3.5
Pot Cap-1 Maneuver	-	-	1444	-	701
Stage 1	-	-	-	-	894
Stage 2	-	-	-	-	877
Platoon blocked, %	-	-	-	-	-
Mov Cap-1 Maneuver	-	-	1444	-	688
Mov Cap-2 Maneuver	-	-	-	-	688
Stage 1	-	-	-	-	894
Stage 2	-	-	-	-	860

Approach	EB	WB	NB
HCM Control Delay, s	0	1.7	9.5
HCM LOS			A

Minor Lane/Major Mvmt	NBLn1	NBLn2	EBT	EBR	WBL	WBT
Capacity (veh/h)	688	916	-	-	1444	-
HCM Lane V/C Ratio	0.025	0.038	-	-	0.02	-
HCM Control Delay (s)	10.4	9.1	-	-	7.5	-
HCM Lane LOS	B	A	-	-	A	-
HCM 95th %tile Q(veh)	0.1	0.1	-	-	0.1	-

HCM 6th TWSC  
 2: North Site Access/Triborough Trail & Londonderry Dr

10/09/2023

Intersection												
Int Delay, s/veh	4.5											
Movement	EBL	EBT	EBR	WBL	WBT	WBR	NBL	NBT	NBR	SBL	SBT	SBR
Lane Configurations		↕			↕			↕			↕	
Traffic Vol, veh/h	0	45	2	25	33	15	1	1	25	20	1	0
Future Vol, veh/h	0	45	2	25	33	15	1	1	25	20	1	0
Conflicting Peds, #/hr	0	0	0	0	0	0	0	0	0	0	0	0
Sign Control	Free	Free	Free	Free	Free	Free	Stop	Stop	Stop	Stop	Stop	Stop
RT Channelized	-	-	None	-	-	None	-	-	None	-	-	None
Storage Length	-	-	-	-	-	-	-	-	-	-	-	-
Veh in Median Storage, #	-	0	-	-	0	-	-	0	-	-	0	-
Grade, %	-	0	-	-	0	-	-	0	-	-	0	-
Peak Hour Factor	78	78	50	50	78	78	50	50	50	75	50	75
Heavy Vehicles, %	0	0	0	0	0	0	0	0	0	0	0	0
Mvmt Flow	0	58	4	50	42	19	2	2	50	27	2	0

Major/Minor	Major1		Major2		Minor1		Minor2					
Conflicting Flow All	61	0	0	62	0	0	213	221	60	238	214	52
Stage 1	-	-	-	-	-	-	60	60	-	152	152	-
Stage 2	-	-	-	-	-	-	153	161	-	86	62	-
Critical Hdwy	4.1	-	-	4.1	-	-	7.1	6.5	6.2	7.1	6.5	6.2
Critical Hdwy Stg 1	-	-	-	-	-	-	6.1	5.5	-	6.1	5.5	-
Critical Hdwy Stg 2	-	-	-	-	-	-	6.1	5.5	-	6.1	5.5	-
Follow-up Hdwy	2.2	-	-	2.2	-	-	3.5	4	3.3	3.5	4	3.3
Pot Cap-1 Maneuver	1555	-	-	1554	-	-	748	681	1011	721	687	1021
Stage 1	-	-	-	-	-	-	957	849	-	855	775	-
Stage 2	-	-	-	-	-	-	854	769	-	927	847	-
Platoon blocked, %	-	-	-	-	-	-	-	-	-	-	-	-
Mov Cap-1 Maneuver	1555	-	-	1554	-	-	728	659	1011	666	664	1021
Mov Cap-2 Maneuver	-	-	-	-	-	-	728	659	-	666	664	-
Stage 1	-	-	-	-	-	-	957	849	-	855	749	-
Stage 2	-	-	-	-	-	-	824	744	-	879	847	-

Approach	EB	WB	NB	SB
HCM Control Delay, s	0	3.3	8.9	10.6
HCM LOS			A	B

Minor Lane/Major Mvmt	NBLn1	EBL	EBT	EBR	WBL	WBT	WBR	SBLn1
Capacity (veh/h)	978	1555	-	-	1554	-	-	666
HCM Lane V/C Ratio	0.055	-	-	-	0.032	-	-	0.043
HCM Control Delay (s)	8.9	0	-	-	7.4	0	-	10.6
HCM Lane LOS	A	A	-	-	A	A	-	B
HCM 95th %tile Q(veh)	0.2	0	-	-	0.1	-	-	0.1

HCM 6th TWSC  
3: Towner Ave & East Site Access

10/09/2023

Intersection												
Int Delay, s/veh	5.1											
Movement	EBL	EBT	EBR	WBL	WBT	WBR	NBL	NBT	NBR	SBL	SBT	SBR
Lane Configurations		↕			↕			↕			↕	
Traffic Vol, veh/h	14	0	24	0	0	0	24	25	0	0	21	11
Future Vol, veh/h	14	0	24	0	0	0	24	25	0	0	21	11
Conflicting Peds, #/hr	0	0	0	0	0	0	0	0	0	0	0	0
Sign Control	Stop	Stop	Stop	Stop	Stop	Stop	Free	Free	Free	Free	Free	Free
RT Channelized	-	-	None	-	-	None	-	-	None	-	-	None
Storage Length	-	-	-	-	-	-	-	-	-	-	-	-
Veh in Median Storage, #	-	0	-	-	0	-	-	0	-	-	0	-
Grade, %	-	0	-	-	0	-	-	0	-	-	0	-
Peak Hour Factor	50	50	50	75	75	75	50	75	75	75	75	50
Heavy Vehicles, %	0	0	0	0	0	0	0	0	0	0	0	0
Mvmt Flow	28	0	48	0	0	0	48	33	0	0	28	22

Major/Minor	Minor2		Minor1			Major1			Major2			
Conflicting Flow All	168	168	39	192	179	33	50	0	0	33	0	0
Stage 1	39	39	-	129	129	-	-	-	-	-	-	-
Stage 2	129	129	-	63	50	-	-	-	-	-	-	-
Critical Hdwy	7.1	6.5	6.2	7.1	6.5	6.2	4.1	-	-	4.1	-	-
Critical Hdwy Stg 1	6.1	5.5	-	6.1	5.5	-	-	-	-	-	-	-
Critical Hdwy Stg 2	6.1	5.5	-	6.1	5.5	-	-	-	-	-	-	-
Follow-up Hdwy	3.5	4	3.3	3.5	4	3.3	2.2	-	-	2.2	-	-
Pot Cap-1 Maneuver	800	728	1038	772	718	1046	1570	-	-	1592	-	-
Stage 1	981	866	-	880	793	-	-	-	-	-	-	-
Stage 2	880	793	-	953	857	-	-	-	-	-	-	-
Platoon blocked, %								-	-	-	-	-
Mov Cap-1 Maneuver	781	705	1038	719	696	1046	1570	-	-	1592	-	-
Mov Cap-2 Maneuver	781	705	-	719	696	-	-	-	-	-	-	-
Stage 1	951	866	-	853	768	-	-	-	-	-	-	-
Stage 2	853	768	-	909	857	-	-	-	-	-	-	-

Approach	EB	WB	NB	SB
HCM Control Delay, s	9.2	0	4.3	0
HCM LOS	A	A		

Minor Lane/Major Mvmt	NBL	NBT	NBR	EBLn1	WBLn1	SBL	SBT	SBR
Capacity (veh/h)	1570	-	-	926	-	1592	-	-
HCM Lane V/C Ratio	0.031	-	-	0.082	-	-	-	-
HCM Control Delay (s)	7.4	0	-	9.2	0	0	-	-
HCM Lane LOS	A	A	-	A	A	A	-	-
HCM 95th %tile Q(veh)	0.1	-	-	0.3	-	0	-	-

Intersection						
Int Delay, s/veh	3.7					
Movement	EBT	EBR	WBL	WBT	NBL	NBR
Lane Configurations	↶		↷	↶	↷	↷
Traffic Vol, veh/h	60	25	25	50	35	30
Future Vol, veh/h	60	25	25	50	35	30
Conflicting Peds, #/hr	0	0	0	0	0	0
Sign Control	Free	Free	Free	Free	Stop	Stop
RT Channelized	-	None	-	None	-	None
Storage Length	-	-	0	-	0	0
Veh in Median Storage, #	0	-	-	0	0	-
Grade, %	0	-	-	0	0	-
Peak Hour Factor	82	82	75	78	76	76
Heavy Vehicles, %	0	0	0	0	0	0
Mvmt Flow	73	30	33	64	46	39

Major/Minor	Major1	Major2	Minor1		
Conflicting Flow All	0	0	103	0	218 88
Stage 1	-	-	-	-	88 -
Stage 2	-	-	-	-	130 -
Critical Hdwy	-	-	4.1	-	6.4 6.2
Critical Hdwy Stg 1	-	-	-	-	5.4 -
Critical Hdwy Stg 2	-	-	-	-	5.4 -
Follow-up Hdwy	-	-	2.2	-	3.5 3.3
Pot Cap-1 Maneuver	-	-	1502	-	775 976
Stage 1	-	-	-	-	940 -
Stage 2	-	-	-	-	901 -
Platoon blocked, %	-	-	-	-	-
Mov Cap-1 Maneuver	-	-	1502	-	758 976
Mov Cap-2 Maneuver	-	-	-	-	758 -
Stage 1	-	-	-	-	940 -
Stage 2	-	-	-	-	881 -

Approach	EB	WB	NB
HCM Control Delay, s	0	2.5	9.5
HCM LOS			A

Minor Lane/Major Mvmt	NBLn1	NBLn2	EBT	EBR	WBL	WBT
Capacity (veh/h)	758	976	-	-	1502	-
HCM Lane V/C Ratio	0.061	0.04	-	-	0.022	-
HCM Control Delay (s)	10.1	8.8	-	-	7.5	-
HCM Lane LOS	B	A	-	-	A	-
HCM 95th %tile Q(veh)	0.2	0.1	-	-	0.1	-



HCM 6th TWSC  
2: Londonderry Dr & Triborough Trail

10/09/2023

Intersection						
Int Delay, s/veh	1.2					
Movement	EBL	EBT	WBT	WBR	SBL	SBR
Lane Configurations		↶	↷		↶	
Traffic Vol, veh/h	0	65	70	15	20	0
Future Vol, veh/h	0	65	70	15	20	0
Conflicting Peds, #/hr	0	0	0	0	0	0
Sign Control	Free	Free	Free	Free	Stop	Stop
RT Channelized	-	None	-	None	-	None
Storage Length	-	-	-	-	0	-
Veh in Median Storage, #	-	0	0	-	0	-
Grade, %	-	0	0	-	0	-
Peak Hour Factor	80	80	82	82	75	75
Heavy Vehicles, %	0	0	0	0	0	0
Mvmt Flow	0	81	85	18	27	0

Major/Minor	Major1	Major2	Minor2		
Conflicting Flow All	103	0	-	0	175 94
Stage 1	-	-	-	-	94 -
Stage 2	-	-	-	-	81 -
Critical Hdwy	4.1	-	-	-	6.4 6.2
Critical Hdwy Stg 1	-	-	-	-	5.4 -
Critical Hdwy Stg 2	-	-	-	-	5.4 -
Follow-up Hdwy	2.2	-	-	-	3.5 3.3
Pot Cap-1 Maneuver	1502	-	-	-	819 968
Stage 1	-	-	-	-	935 -
Stage 2	-	-	-	-	947 -
Platoon blocked, %		-	-	-	
Mov Cap-1 Maneuver	1502	-	-	-	819 968
Mov Cap-2 Maneuver	-	-	-	-	819 -
Stage 1	-	-	-	-	935 -
Stage 2	-	-	-	-	947 -

Approach	EB	WB	SB
HCM Control Delay, s	0	0	9.5
HCM LOS			A

Minor Lane/Major Mvmt	EBL	EBT	WBT	WBR	SBLn1
Capacity (veh/h)	1502	-	-	-	819
HCM Lane V/C Ratio	-	-	-	-	0.033
HCM Control Delay (s)	0	-	-	-	9.5
HCM Lane LOS	A	-	-	-	A
HCM 95th %tile Q(veh)	0	-	-	-	0.1

Intersection						
Int Delay, s/veh	0					
Movement	WBL	WBR	NBT	NBR	SBL	SBT
Lane Configurations						
Traffic Vol, veh/h	0	0	65	0	0	50
Future Vol, veh/h	0	0	65	0	0	50
Conflicting Peds, #/hr	0	0	0	0	0	0
Sign Control	Stop	Stop	Free	Free	Free	Free
RT Channelized	-	None	-	None	-	None
Storage Length	0	-	-	-	-	-
Veh in Median Storage, #	0	-	0	-	-	0
Grade, %	0	-	0	-	-	0
Peak Hour Factor	75	75	80	80	78	78
Heavy Vehicles, %	0	0	0	0	0	0
Mvmt Flow	0	0	81	0	0	64

Major/Minor	Minor1	Major1	Major2			
Conflicting Flow All	145	81	0	0	81	0
Stage 1	81	-	-	-	-	-
Stage 2	64	-	-	-	-	-
Critical Hdwy	6.4	6.2	-	-	4.1	-
Critical Hdwy Stg 1	5.4	-	-	-	-	-
Critical Hdwy Stg 2	5.4	-	-	-	-	-
Follow-up Hdwy	3.5	3.3	-	-	2.2	-
Pot Cap-1 Maneuver	852	985	-	-	1529	-
Stage 1	947	-	-	-	-	-
Stage 2	964	-	-	-	-	-
Platoon blocked, %			-	-	-	-
Mov Cap-1 Maneuver	852	985	-	-	1529	-
Mov Cap-2 Maneuver	852	-	-	-	-	-
Stage 1	947	-	-	-	-	-
Stage 2	964	-	-	-	-	-

Approach	WB	NB	SB
HCM Control Delay, s	0	0	0
HCM LOS	A		

Minor Lane/Major Mvmt	NBT	NBRWBLn1	SBL	SBT
Capacity (veh/h)	-	-	-	1529
HCM Lane V/C Ratio	-	-	-	-
HCM Control Delay (s)	-	-	0	0
HCM Lane LOS	-	-	A	A
HCM 95th %tile Q(veh)	-	-	-	0

Intersection						
Int Delay, s/veh	3.3					
Movement	EBT	EBR	WBL	WBT	NBL	NBR
Lane Configurations						
Traffic Vol, veh/h	95	25	40	85	35	49
Future Vol, veh/h	95	25	40	85	35	49
Conflicting Peds, #/hr	0	0	0	0	0	0
Sign Control	Free	Free	Free	Free	Stop	Stop
RT Channelized	-	None	-	None	-	None
Storage Length	-	-	0	-	0	0
Veh in Median Storage, #	0	-	-	0	0	-
Grade, %	0	-	-	0	0	-
Peak Hour Factor	60	60	60	60	77	78
Heavy Vehicles, %	0	0	0	0	0	0
Mvmt Flow	158	42	67	142	45	63

Major/Minor	Major1	Major2	Minor1		
Conflicting Flow All	0	0	200	0	455 179
Stage 1	-	-	-	-	179 -
Stage 2	-	-	-	-	276 -
Critical Hdwy	-	-	4.1	-	6.4 6.2
Critical Hdwy Stg 1	-	-	-	-	5.4 -
Critical Hdwy Stg 2	-	-	-	-	5.4 -
Follow-up Hdwy	-	-	2.2	-	3.5 3.3
Pot Cap-1 Maneuver	-	-	1384	-	567 869
Stage 1	-	-	-	-	857 -
Stage 2	-	-	-	-	775 -
Platoon blocked, %	-	-	-	-	-
Mov Cap-1 Maneuver	-	-	1384	-	540 869
Mov Cap-2 Maneuver	-	-	-	-	540 -
Stage 1	-	-	-	-	857 -
Stage 2	-	-	-	-	738 -

Approach	EB	WB	NB
HCM Control Delay, s	0	2.5	10.7
HCM LOS			B

Minor Lane/Major Mvmt	NBLn1	NBLn2	EBT	EBR	WBL	WBT
Capacity (veh/h)	540	869	-	-	1384	-
HCM Lane V/C Ratio	0.084	0.072	-	-	0.048	-
HCM Control Delay (s)	12.3	9.5	-	-	7.7	-
HCM Lane LOS	B	A	-	-	A	-
HCM 95th %tile Q(veh)	0.3	0.2	-	-	0.2	-

HCM 6th TWSC  
 2: North Site Access/Triborough Trail & Londonderry Dr

10/09/2023

Intersection												
Int Delay, s/veh	4.3											
Movement	EBL	EBT	EBR	WBL	WBT	WBR	NBL	NBT	NBR	SBL	SBT	SBR
Lane Configurations		↕			↕			↕			↕	
Traffic Vol, veh/h	0	65	3	35	70	15	2	1	35	20	1	0
Future Vol, veh/h	0	65	3	35	70	15	2	1	35	20	1	0
Conflicting Peds, #/hr	0	0	0	0	0	0	0	0	0	0	0	0
Sign Control	Free	Free	Free	Free	Free	Free	Stop	Stop	Stop	Stop	Stop	Stop
RT Channelized	-	-	None	-	-	None	-	-	None	-	-	None
Storage Length	-	-	-	-	-	-	-	-	-	-	-	-
Veh in Median Storage, #	-	0	-	-	0	-	-	0	-	-	0	-
Grade, %	-	0	-	-	0	-	-	0	-	-	0	-
Peak Hour Factor	80	80	50	50	80	80	50	50	50	75	50	75
Heavy Vehicles, %	0	0	0	0	0	0	0	0	0	0	0	0
Mvmt Flow	0	81	6	70	88	19	4	2	70	27	2	0

Major/Minor	Major1		Major2		Minor1		Minor2					
Conflicting Flow All	107	0	0	87	0	0	323	331	84	358	325	98
Stage 1	-	-	-	-	-	-	84	84	-	238	238	-
Stage 2	-	-	-	-	-	-	239	247	-	120	87	-
Critical Hdwy	4.1	-	-	4.1	-	-	7.1	6.5	6.2	7.1	6.5	6.2
Critical Hdwy Stg 1	-	-	-	-	-	-	6.1	5.5	-	6.1	5.5	-
Critical Hdwy Stg 2	-	-	-	-	-	-	6.1	5.5	-	6.1	5.5	-
Follow-up Hdwy	2.2	-	-	2.2	-	-	3.5	4	3.3	3.5	4	3.3
Pot Cap-1 Maneuver	1497	-	-	1522	-	-	634	592	981	601	596	963
Stage 1	-	-	-	-	-	-	929	829	-	770	712	-
Stage 2	-	-	-	-	-	-	769	706	-	889	827	-
Platoon blocked, %		-	-		-	-						
Mov Cap-1 Maneuver	1497	-	-	1522	-	-	609	563	981	535	567	963
Mov Cap-2 Maneuver	-	-	-	-	-	-	609	563	-	535	567	-
Stage 1	-	-	-	-	-	-	929	829	-	770	677	-
Stage 2	-	-	-	-	-	-	729	671	-	824	827	-

Approach	EB	WB	NB	SB
HCM Control Delay, s	0	3	9.2	12.1
HCM LOS			A	B

Minor Lane/Major Mvmt	NBLn1	EBL	EBT	EBR	WBL	WBT	WBR	SBLn1
Capacity (veh/h)	933	1497	-	-	1522	-	-	537
HCM Lane V/C Ratio	0.081	-	-	-	0.046	-	-	0.053
HCM Control Delay (s)	9.2	0	-	-	7.5	0	-	12.1
HCM Lane LOS	A	A	-	-	A	A	-	B
HCM 95th %tile Q(veh)	0.3	0	-	-	0.1	-	-	0.2

HCM 6th TWSC  
3: Towner Ave & East Site Access

10/09/2023

Intersection												
Int Delay, s/veh	4.5											
Movement	EBL	EBT	EBR	WBL	WBT	WBR	NBL	NBT	NBR	SBL	SBT	SBR
Lane Configurations		↕			↕			↕			↕	
Traffic Vol, veh/h	19	0	34	0	0	0	33	65	0	0	50	15
Future Vol, veh/h	19	0	34	0	0	0	33	65	0	0	50	15
Conflicting Peds, #/hr	0	0	0	0	0	0	0	0	0	0	0	0
Sign Control	Stop	Stop	Stop	Stop	Stop	Stop	Free	Free	Free	Free	Free	Free
RT Channelized	-	-	None	-	-	None	-	-	None	-	-	None
Storage Length	-	-	-	-	-	-	-	-	-	-	-	-
Veh in Median Storage, #	-	0	-	-	0	-	-	0	-	-	0	-
Grade, %	-	0	-	-	0	-	-	0	-	-	0	-
Peak Hour Factor	50	50	50	75	75	75	50	80	80	78	78	50
Heavy Vehicles, %	0	0	0	0	0	0	0	0	0	0	0	0
Mvmt Flow	38	0	68	0	0	0	66	81	0	0	64	30

Major/Minor	Minor2		Minor1			Major1			Major2			
Conflicting Flow All	292	292	79	326	307	81	94	0	0	81	0	0
Stage 1	79	79	-	213	213	-	-	-	-	-	-	-
Stage 2	213	213	-	113	94	-	-	-	-	-	-	-
Critical Hdwy	7.1	6.5	6.2	7.1	6.5	6.2	4.1	-	-	4.1	-	-
Critical Hdwy Stg 1	6.1	5.5	-	6.1	5.5	-	-	-	-	-	-	-
Critical Hdwy Stg 2	6.1	5.5	-	6.1	5.5	-	-	-	-	-	-	-
Follow-up Hdwy	3.5	4	3.3	3.5	4	3.3	2.2	-	-	2.2	-	-
Pot Cap-1 Maneuver	664	622	987	631	610	985	1513	-	-	1529	-	-
Stage 1	935	833	-	794	730	-	-	-	-	-	-	-
Stage 2	794	730	-	897	821	-	-	-	-	-	-	-
Platoon blocked, %								-	-	-	-	-
Mov Cap-1 Maneuver	641	593	987	567	582	985	1513	-	-	1529	-	-
Mov Cap-2 Maneuver	641	593	-	567	582	-	-	-	-	-	-	-
Stage 1	892	833	-	757	696	-	-	-	-	-	-	-
Stage 2	757	696	-	835	821	-	-	-	-	-	-	-

Approach	EB	WB	NB	SB
HCM Control Delay, s	10	0	3.4	0
HCM LOS	B	A		

Minor Lane/Major Mvmt	NBL	NBT	NBR	EBLn1WBLn1	SBL	SBT	SBR
Capacity (veh/h)	1513	-	-	827	-	1529	-
HCM Lane V/C Ratio	0.044	-	-	0.128	-	-	-
HCM Control Delay (s)	7.5	0	-	10	0	0	-
HCM Lane LOS	A	A	-	B	A	A	-
HCM 95th %tile Q(veh)	0.1	-	-	0.4	-	0	-

### Appendix Table 1

#### Percent Impact Calculations for Potential Study Area Intersections

(ECM Appendix B.2.3)

Offsite Intersection Approach	Site Trip Direction	Projected Sunday Site-Generated AM Peak Traffic (veh/hr)	RATIO of Site AM Weekday PeakTrips to Sunday Peak Hour Trips (Trip Generation Ratio)	RATIO of Site AM Weekday PeakTrips to Sunday Peak Hour Trips (decimal/factor)	Approx Weekday AM Peak Traffic (veh/hr)	Trips from 2018 or 2020 Count Data	Percent Impact	Vs. ECM Threshold
SB Towner at S Londonderry Int.	Outbound	34	2/92	0.02	1	156	0.5%	< 10%
NB Towner at S Londonderry Int.	Inbound	33	5/88	0.06	2	304	0.6%	< 10%
SB Towner at Stapleton	Outbound (MAX)	34	2/92	0.02	1	323	0.2%	< 10%
EB Londonderry at Meridian	Outbound (MAX)	54	2/92	0.02	1	445	0.3%	< 10%

# LSC Transportation Consultants, Inc.

545 E Pikes Peak Ave, Suite 210  
 Colorado Springs, CO 80905  
 719-633-2868

File Name : Meridian Rd - Londonderry Dr AM  
 Site Code : 00194180  
 Start Date : 2/20/2020  
 Page No : 1

### Groups Printed- Unshifted

Start Time	Meridian Rd Southbound					Londonderry Dr Westbound					Meridian Rd Northbound					Londonderry Dr Eastbound					Int. Total
	L	T	R	U	App. Total	L	T	R	U	App. Total	L	T	R	U	App. Total	L	T	R	U	App. Total	
06:30 AM	0	97	2	0	99	74	4	4	0	82	2	30	5	0	37	6	8	32	0	46	264
06:45 AM	7	123	4	0	134	108	8	17	0	133	0	45	20	0	65	12	15	33	0	60	392
Total	7	220	6	0	233	182	12	21	0	215	2	75	25	0	102	18	23	65	0	106	656
07:00 AM	15	71	14	0	100	114	40	34	0	188	9	73	25	0	107	29	27	38	0	94	489
07:15 AM	9	108	31	0	148	81	76	28	0	185	22	101	25	0	148	32	33	38	0	103	584
07:30 AM	12	116	36	0	164	68	31	41	4	144	27	147	13	0	187	36	33	61	0	130	625
07:45 AM	17	121	16	0	154	58	5	13	0	76	21	104	34	0	159	34	18	65	1	118	507
Total	53	416	97	0	566	321	152	116	4	593	79	425	97	0	601	131	111	202	1	445	2205
08:00 AM	13	110	9	0	132	78	7	13	0	98	21	51	38	0	110	8	10	17	0	35	375
08:15 AM	11	71	1	0	83	96	10	18	0	124	10	66	38	0	114	6	8	26	0	40	361
Grand Total	84	817	113	0	1014	677	181	168	4	1030	112	617	198	0	927	163	152	310	1	626	3597
Apprch %	8.3	80.6	11.1	0		65.7	17.6	16.3	0.4		12.1	66.6	21.4	0		26	24.3	49.5	0.2		
Total %	2.3	22.7	3.1	0	28.2	18.8	5	4.7	0.1	28.6	3.1	17.2	5.5	0	25.8	4.5	4.2	8.6	0	17.4	

# LSC Transportation Consultants, Inc.

545 E Pikes Peak Ave, Suite 210  
 Colorado Springs, CO 80905  
 719-633-2868

File Name : Meridian Rd - Londonderry Dr AM  
 Site Code : 00194180  
 Start Date : 2/20/2020  
 Page No : 2

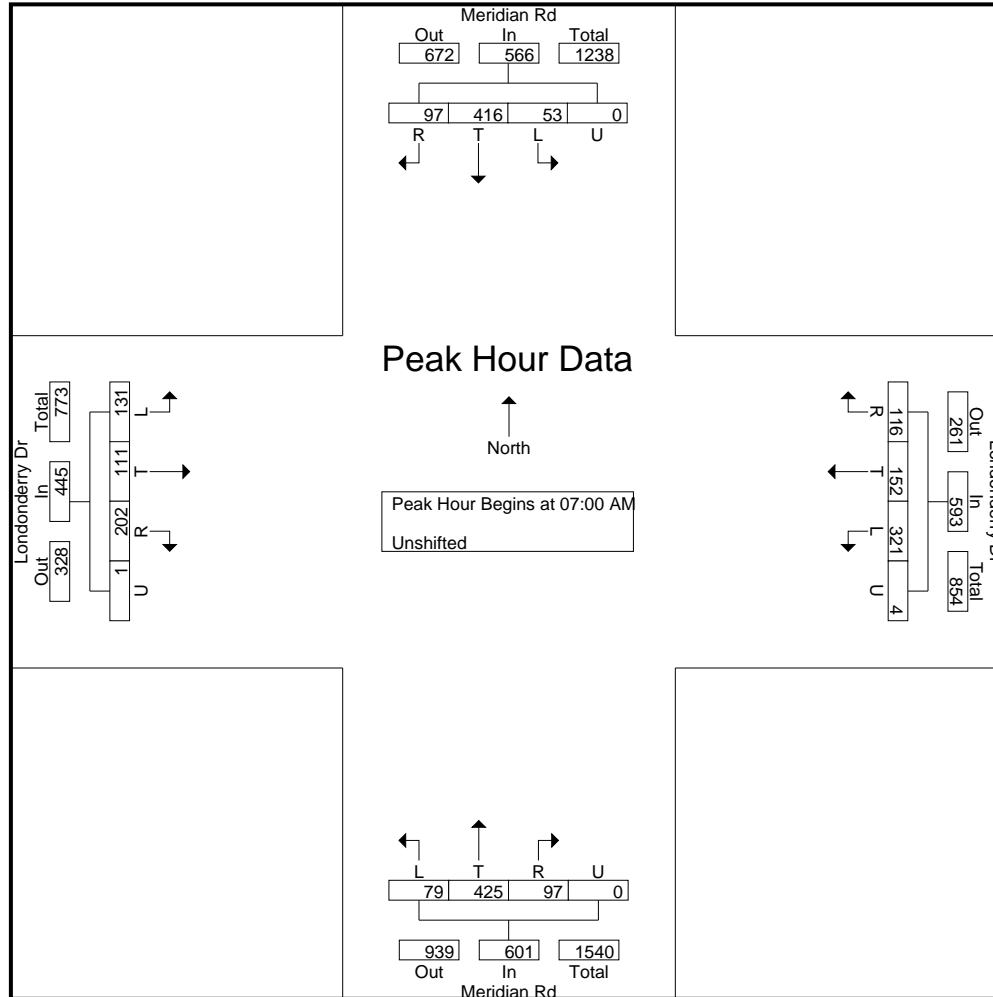
Start Time	Meridian Rd Southbound					Londonderry Dr Westbound					Meridian Rd Northbound					Londonderry Dr Eastbound					Int. Total
	L	T	R	U	App. Total	L	T	R	U	App. Total	L	T	R	U	App. Total	L	T	R	U	App. Total	
<b>Peak Hour Analysis From 6:30:00 AM to 8:15:00 AM - Peak 1 of 1</b>																					
Peak Hour for Entire Intersection Begins at 7:00:00 AM																					
7:00:00 AM	15	71	14	0	100	114	40	34	0	188	9	73	25	0	107	29	27	38	0	94	489
7:15:00 AM	9	108	31	0	148	81	76	28	0	185	22	101	25	0	148	32	33	38	0	103	584
7:30:00 AM	12	116	36	0	164	68	31	41	4	144	27	147	13	0	187	36	33	61	0	130	625
7:45:00 AM	17	121	16	0	154	58	5	13	0	76	21	104	34	0	159	34	18	65	1	118	507
Total Volume	53	416	97	0	566	321	152	116	4	593	79	425	97	0	601	131	111	202	1	445	2205
% App. Total	9.4	73.5	17.1	0		54.1	25.6	19.6	0.7		13.1	70.7	16.1	0		29.4	24.9	45.4	0.2		
PHF	.779	.860	.674	.000	.863	.704	.500	.707	.250	.789	.731	.723	.713	.000	.803	.910	.841	.777	.250	.856	.882



# LSC Transportation Consultants, Inc.

545 E Pikes Peak Ave, Suite 210  
 Colorado Springs, CO 80905  
 719-633-2868

File Name : Meridian Rd - Londonderry Dr AM  
 Site Code : 00194180  
 Start Date : 2/20/2020  
 Page No : 3



# LSC Transportation Consultants, Inc.

545 E Pikes Peak Ave, Suite 210  
 Colorado Springs, CO 80905  
 719-633-2868

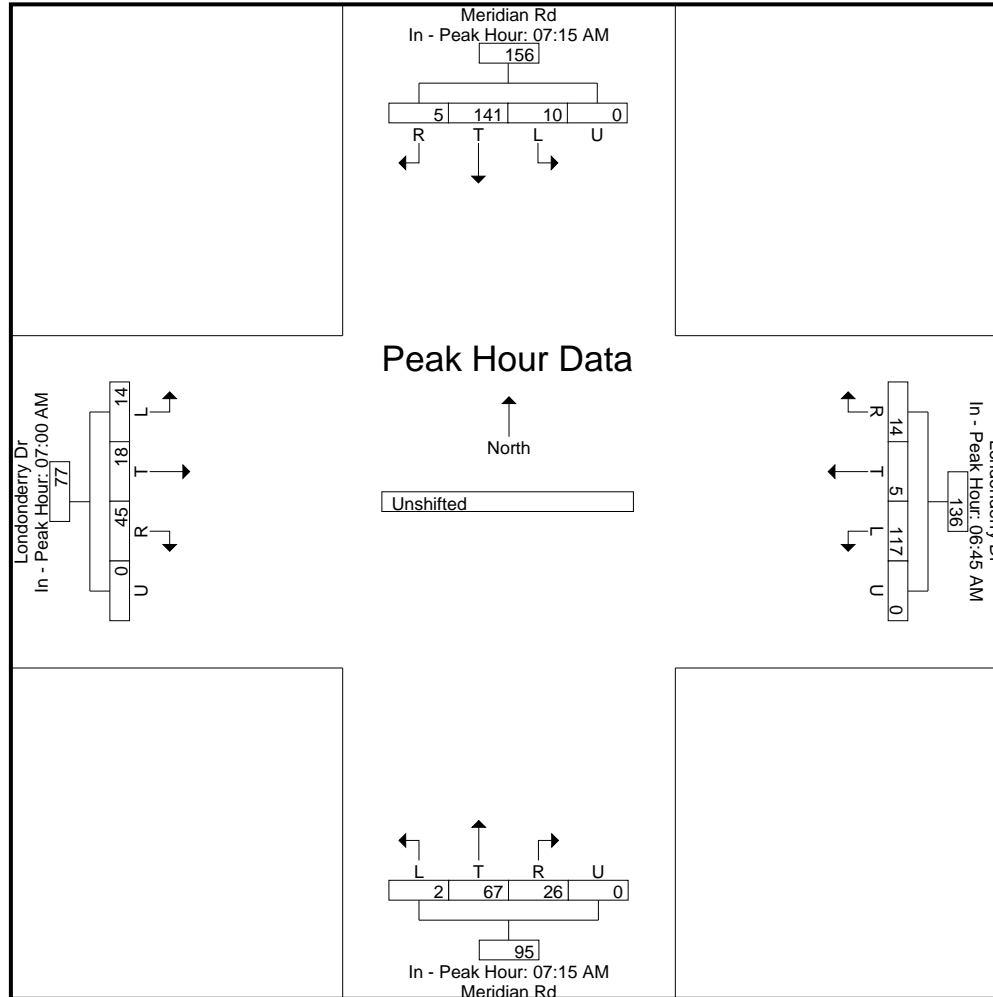
File Name : Meridian Rd - Londonderry Dr AM  
 Site Code : 00194180  
 Start Date : 2/20/2020  
 Page No : 4

Start Time	Meridian Rd Southbound					Londonderry Dr Westbound					Meridian Rd Northbound					Londonderry Dr Eastbound					Int. Total
	L	T	R	U	App. Total	L	T	R	U	App. Total	L	T	R	U	App. Total	L	T	R	U	App. Total	
<b>Peak Hour Analysis From 6:30:00 AM to 8:15:00 AM - Peak 1 of 1</b>																					
Peak Hour for Each Approach Begins at:																					
	7:15:00 AM					6:45:00 AM					7:15:00 AM					7:00:00 AM					
+0 mins.	9	108	31	0	148	108	8	17	0	133	22	101	25	0	148	29	27	38	0	94	
+5 mins.	12	116	<b>36</b>	0	<b>164</b>	<b>114</b>	40	34	0	<b>188</b>	<b>27</b>	<b>147</b>	13	0	<b>187</b>	32	<b>33</b>	38	0	103	
+10 mins.	<b>17</b>	<b>121</b>	16	0	154	81	<b>76</b>	28	0	185	21	104	34	0	159	<b>36</b>	33	61	0	<b>130</b>	
+15 mins.	13	110	9	0	132	68	31	<b>41</b>	<b>4</b>	144	21	51	<b>38</b>	0	110	34	18	<b>65</b>	<b>1</b>	118	
Total Volume	51	455	92	0	598	371	155	120	4	650	91	403	110	0	604	131	111	202	1	445	
% App. Total	8.5	76.1	15.4	0		57.1	23.8	18.5	0.6		15.1	66.7	18.2	0		29.4	24.9	45.4	0.2		
PHF	.750	.940	.639	.000	.912	.814	.510	.732	.250	.864	.843	.685	.724	.000	.807	.910	.841	.777	.250	.856	

# LSC Transportation Consultants, Inc.

545 E Pikes Peak Ave, Suite 210  
 Colorado Springs, CO 80905  
 719-633-2868

File Name : Meridian Rd - Londonderry Dr AM  
 Site Code : 00194180  
 Start Date : 2/20/2020  
 Page No : 5



# LSC Transportation Consultants, Inc.

545 E Pikes Peak Ave, Suite 210  
 Colorado Springs, CO 80905  
 719-633-2868

File Name : Meridian Rd - Londonderry Dr PM  
 Site Code : 00194180  
 Start Date : 2/20/2020  
 Page No : 1

### Groups Printed- Unshifted

Start Time	Meridian Rd Southbound					Londonderry Dr Westbound					Meridian Rd Northbound					Londonderry Dr Eastbound					Int. Total
	L	T	R	U	App. Total	L	T	R	U	App. Total	L	T	R	U	App. Total	L	T	R	U	App. Total	
04:00 PM	10	104	23	0	137	49	5	4	0	58	37	84	56	0	177	6	1	9	0	16	388
04:15 PM	21	79	16	0	116	41	5	8	0	54	28	105	70	0	203	11	6	26	0	43	416
04:30 PM	14	85	13	0	112	60	4	7	0	71	34	114	82	0	230	5	9	22	0	36	449
04:45 PM	19	67	17	0	103	47	14	8	0	69	27	97	88	0	212	5	3	20	0	28	412
Total	64	335	69	0	468	197	28	27	0	252	126	400	296	0	822	27	19	77	0	123	1665
05:00 PM	17	76	14	0	107	52	9	7	0	68	23	122	83	0	228	11	19	20	0	50	453
05:15 PM	25	78	21	0	124	58	5	8	0	71	22	117	81	0	220	5	7	22	0	34	449
05:30 PM	15	83	18	0	116	64	4	7	0	75	27	117	89	0	233	4	2	23	0	29	453
05:45 PM	14	65	9	0	88	62	7	8	0	77	28	97	102	0	227	3	8	16	0	27	419
Total	71	302	62	0	435	236	25	30	0	291	100	453	355	0	908	23	36	81	0	140	1774
Grand Total	135	637	131	0	903	433	53	57	0	543	226	853	651	0	1730	50	55	158	0	263	3439
Apprch %	15	70.5	14.5	0		79.7	9.8	10.5	0		13.1	49.3	37.6	0		19	20.9	60.1	0		
Total %	3.9	18.5	3.8	0	26.3	12.6	1.5	1.7	0	15.8	6.6	24.8	18.9	0	50.3	1.5	1.6	4.6	0	7.6	

# LSC Transportation Consultants, Inc.

545 E Pikes Peak Ave, Suite 210  
 Colorado Springs, CO 80905  
 719-633-2868

File Name : Meridian Rd - Londonderry Dr PM  
 Site Code : 00194180  
 Start Date : 2/20/2020  
 Page No : 2

Start Time	Meridian Rd Southbound					Londonderry Dr Westbound					Meridian Rd Northbound					Londonderry Dr Eastbound					Int. Total
	L	T	R	U	App. Total	L	T	R	U	App. Total	L	T	R	U	App. Total	L	T	R	U	App. Total	
<b>Peak Hour Analysis From 4:00:00 PM to 5:45:00 PM - Peak 1 of 1</b>																					
Peak Hour for Entire Intersection Begins at 5:00:00 PM																					
5:00:00 PM	17	76	14	0	107	52	9	7	0	68	23	122	83	0	228	11	19	20	0	50	453
5:15:00 PM	25	78	21	0	124	58	5	8	0	71	22	117	81	0	220	5	7	22	0	34	449
5:30:00 PM	15	83	18	0	116	64	4	7	0	75	27	117	89	0	233	4	2	23	0	29	453
5:45:00 PM	14	65	9	0	88	62	7	8	0	77	28	97	102	0	227	3	8	16	0	27	419
Total Volume	71	302	62	0	435	236	25	30	0	291	100	453	355	0	908	23	36	81	0	140	1774
% App. Total	16.3	69.4	14.3	0		81.1	8.6	10.3	0		11	49.9	39.1	0		16.4	25.7	57.9	0		
PHF	.710	.910	.738	.000	.877	.922	.694	.938	.000	.945	.893	.928	.870	.000	.974	.523	.474	.880	.000	.700	.979

# LSC Transportation Consultants, Inc.

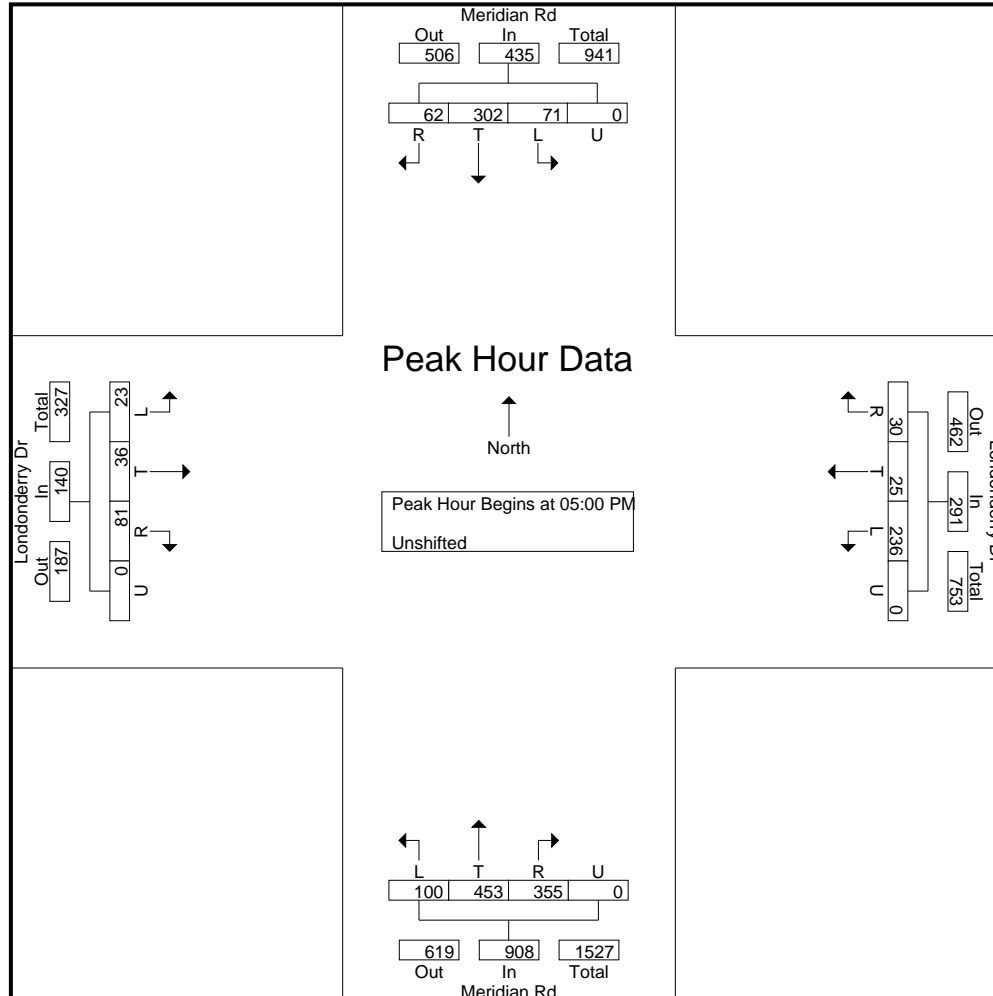
545 E Pikes Peak Ave, Suite 210  
 Colorado Springs, CO 80905  
 719-633-2868

File Name : Meridian Rd - Londonderry Dr PM

Site Code : 00194180

Start Date : 2/20/2020

Page No : 3



# LSC Transportation Consultants, Inc.

545 E Pikes Peak Ave, Suite 210  
 Colorado Springs, CO 80905  
 719-633-2868

File Name : Meridian Rd - Londonderry Dr PM  
 Site Code : 00194180  
 Start Date : 2/20/2020  
 Page No : 4

Start Time	Meridian Rd Southbound					Londonderry Dr Westbound					Meridian Rd Northbound					Londonderry Dr Eastbound					Int. Total
	L	T	R	U	App. Total	L	T	R	U	App. Total	L	T	R	U	App. Total	L	T	R	U	App. Total	

**Peak Hour Analysis From 4:00:00 PM to 5:45:00 PM - Peak 1 of 1**

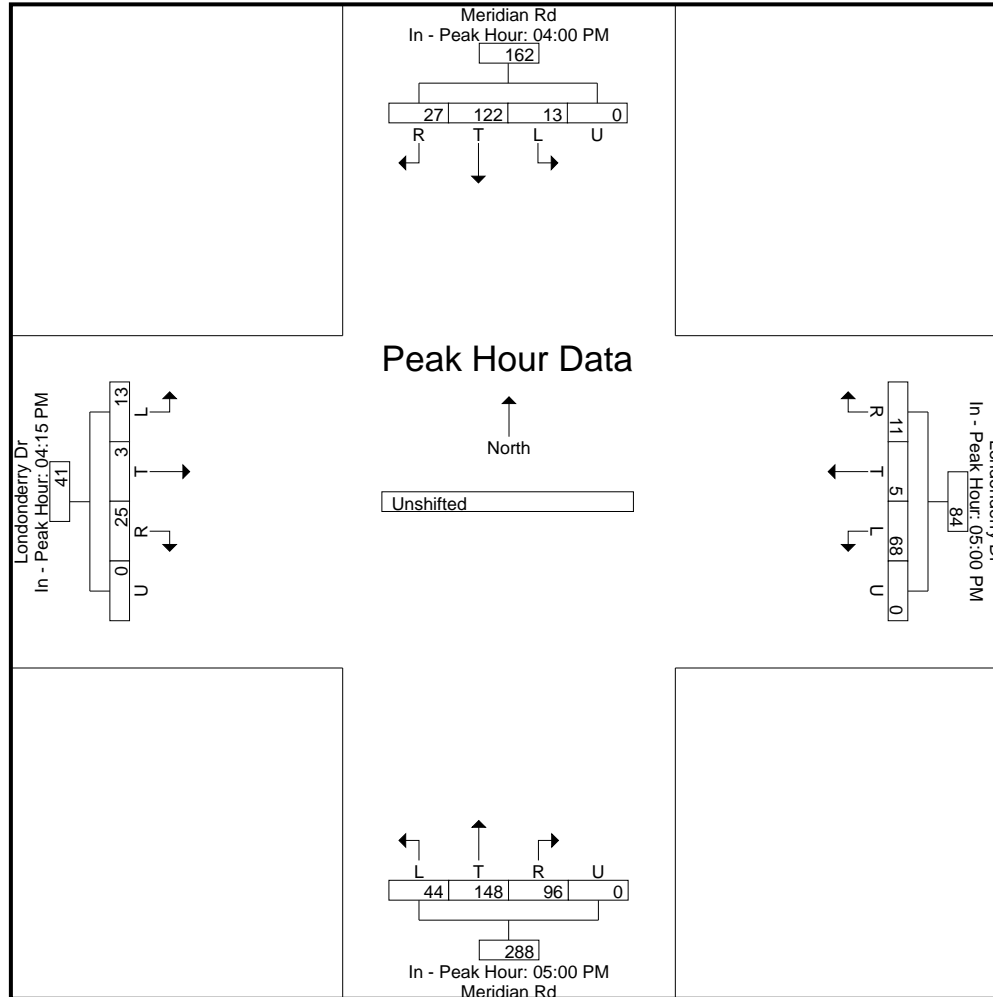
Peak Hour for Each Approach Begins at:

	4:00:00 PM					5:00:00 PM					5:00:00 PM					4:15:00 PM				
+0 mins.	10	<b>104</b>	<b>23</b>	0	<b>137</b>	52	<b>9</b>	7	0	68	23	<b>122</b>	83	0	228	<b>11</b>	6	<b>26</b>	0	43
+5 mins.	<b>21</b>	79	16	0	116	58	5	<b>8</b>	0	71	22	117	81	0	220	5	9	22	0	36
+10 mins.	14	85	13	0	112	<b>64</b>	4	7	0	75	27	117	89	0	<b>233</b>	5	3	20	0	28
+15 mins.	19	67	17	0	103	62	7	8	0	<b>77</b>	<b>28</b>	97	<b>102</b>	0	227	11	<b>19</b>	20	0	<b>50</b>
Total Volume	64	335	69	0	468	236	25	30	0	291	100	453	355	0	908	32	37	88	0	157
% App. Total	13.7	71.6	14.7	0		81.1	8.6	10.3	0		11	49.9	39.1	0		20.4	23.6	56.1	0	
PHF	.762	.805	.750	.000	.854	.922	.694	.938	.000	.945	.893	.928	.870	.000	.974	.727	.487	.846	.000	.785

# LSC Transportation Consultants, Inc.

545 E Pikes Peak Ave, Suite 210  
 Colorado Springs, CO 80905  
 719-633-2868

File Name : Meridian Rd - Londonderry Dr PM  
 Site Code : 00194180  
 Start Date : 2/20/2020  
 Page No : 5





# LSC Transportation Consultants, Inc.

545 E Pikes Peak Ave, Suite 210

Colorado Springs, CO 80905

719-633-2868

File Name : S Towner Ave - Londonderry Dr AM

Site Code : 00184630

Start Date : 9/25/2018

Page No : 1

## Groups Printed- Unshifted

Start Time	S Towner Ave Southbound				Londonderry Dr Westbound				S Towner Ave Northbound				Londonderry Dr Eastbound				Int. Total
	Left	Thru	Right	Peds	Left	Thru	Right	Peds	Left	Thru	Right	Peds	Left	Thru	Right	Peds	
06:30	0	3	1	0	1	0	0	0	1	8	1	0	0	1	18	0	34
06:45	1	11	1	0	0	0	3	0	10	26	0	0	0	0	14	0	66
Total	1	14	2	0	1	0	3	0	11	34	1	0	0	1	32	0	100
07:00	4	36	0	0	3	0	1	0	6	50	3	0	2	0	22	0	127
07:15	4	34	2	0	0	0	2	0	7	82	6	0	4	1	22	0	164
07:30	1	34	1	0	6	0	9	0	7	104	4	0	1	2	29	0	198
07:45	3	37	0	0	1	0	4	0	4	30	1	0	2	1	16	0	99
Total	12	141	3	0	10	0	16	0	24	266	14	0	9	4	89	0	588
08:00	3	10	0	0	0	0	1	0	12	18	1	0	0	0	12	0	57
08:15	3	18	2	0	1	0	1	0	4	18	1	0	2	0	11	0	61
Grand Total	19	183	7	0	12	0	21	0	51	336	17	0	11	5	144	0	806
Apprch %	9.1	87.6	3.3	0	36.4	0	63.6	0	12.6	83.2	4.2	0	6.9	3.1	90	0	
Total %	2.4	22.7	0.9	0	1.5	0	2.6	0	6.3	41.7	2.1	0	1.4	0.6	17.9	0	

# LSC Transportation Consultants, Inc.

545 E Pikes Peak Ave, Suite 210

Colorado Springs, CO 80905

719-633-2868

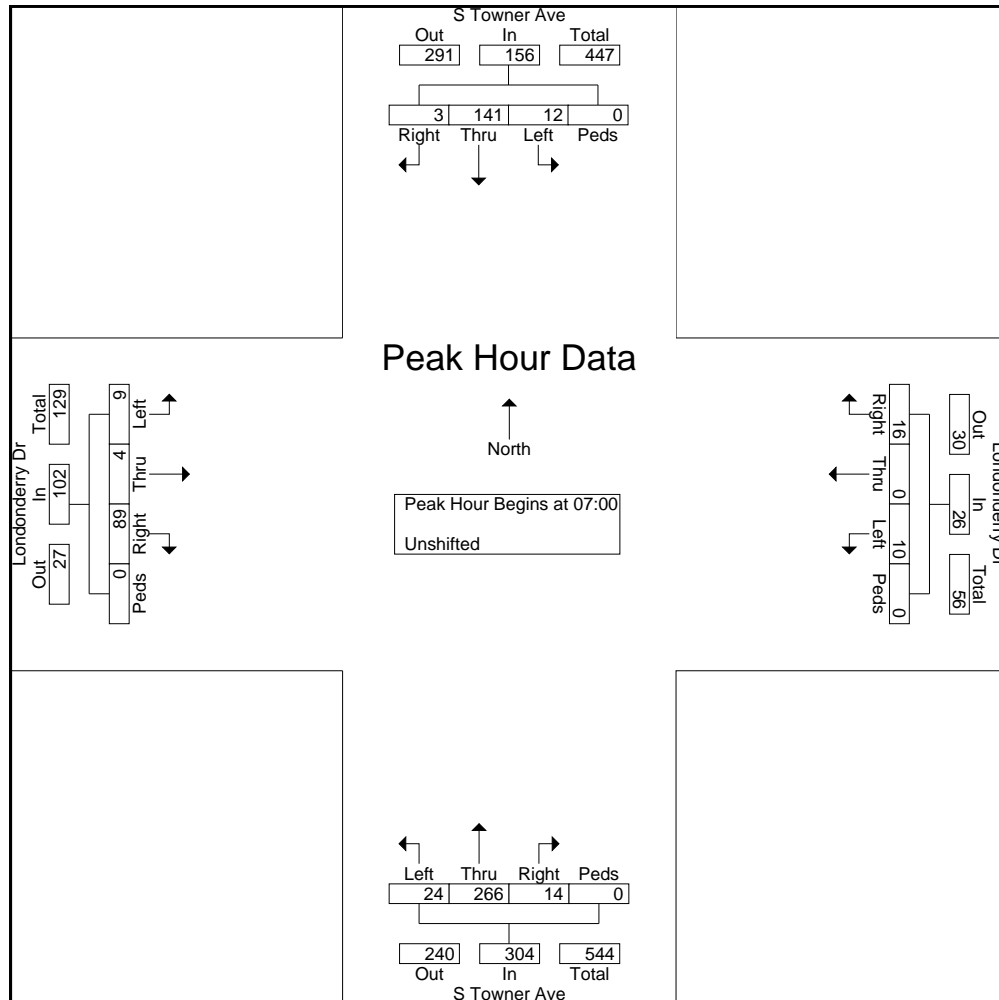
File Name : S Towner Ave - Londonderry Dr AM

Site Code : 00184630

Start Date : 9/25/2018

Page No : 2

Start Time	S Towner Ave Southbound					Londonderry Dr Westbound					S Towner Ave Northbound					Londonderry Dr Eastbound					Int. Total
	Left	Thru	Right	Peds	App. Total	Left	Thru	Right	Peds	App. Total	Left	Thru	Right	Peds	App. Total	Left	Thru	Right	Peds	App. Total	
Peak Hour Analysis From 6:30:00 AM to 8:15:00 AM - Peak 1 of 1																					
Peak Hour for Entire Intersection Begins at 7:00:00 AM																					
7:00:00 AM	4	36	0	0	40	3	0	1	0	4	6	50	3	0	59	2	0	22	0	24	127
7:15:00 AM	4	34	2	0	40	0	0	2	0	2	7	82	6	0	95	4	1	22	0	27	164
7:30:00 AM	1	34	1	0	36	6	0	9	0	15	7	104	4	0	115	1	2	29	0	32	198
7:45:00 AM	3	37	0	0	40	1	0	4	0	5	4	30	1	0	35	2	1	16	0	19	99
Total Volume	12	141	3	0	156	10	0	16	0	26	24	266	14	0	304	9	4	89	0	102	588
% App. Total	7.7	90.4	1.9	0		38.5	0	61.5	0		7.9	87.5	4.6	0		8.8	3.9	87.3	0		
PHF	.750	.953	.375	.000	.975	.417	.000	.444	.000	.433	.857	.639	.583	.000	.661	.563	.500	.767	.000	.797	.742



# LSC Transportation Consultants, Inc.

545 E Pikes Peak Ave, Suite 210

Colorado Springs, CO 80905

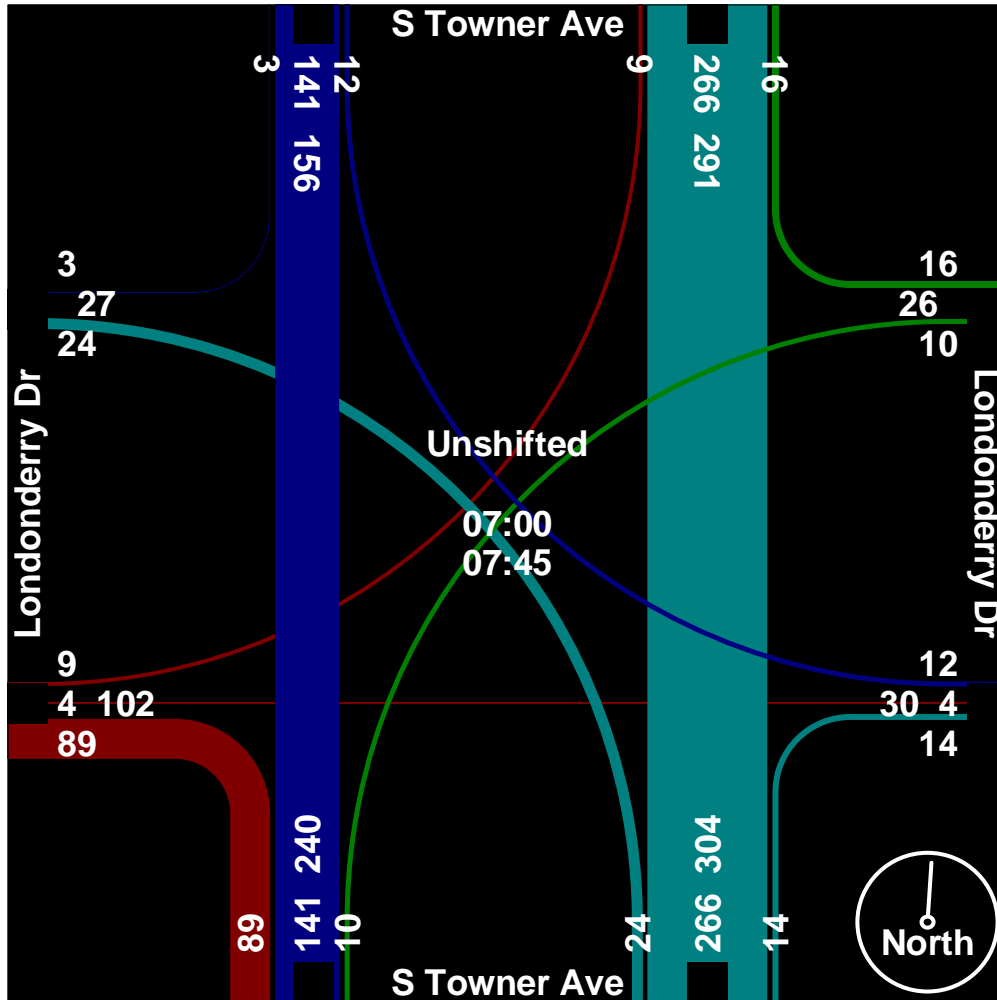
719-633-2868

File Name : S Towner Ave - Londonderry Dr AM

Site Code : 00184630

Start Date : 9/25/2018

Page No : 3



# LSC Transportation Consultants, Inc.

545 E Pikes Peak Ave, Suite 210

Colorado Springs, CO 80905

719-633-2868

File Name : S Towner Ave - Londonderry Dr PM

Site Code : 00184630

Start Date : 9/25/2018

Page No : 1

### Groups Printed- Unshifted

Start Time	S Towner Ave Southbound				Londonderry Dr Westbound				S Towner Ave Northbound				Londonderry Dr Eastbound				Int. Total
	Left	Thru	Right	Peds	Left	Thru	Right	Peds	Left	Thru	Right	Peds	Left	Thru	Right	Peds	
16:30	3	7	0	0	0	1	0	0	14	6	1	0	1	0	16	0	49
16:45	0	3	1	0	0	0	0	0	20	25	1	0	1	0	12	0	63
Total	3	10	1	0	0	1	0	0	34	31	2	0	2	0	28	0	112
17:00	1	7	0	0	1	0	0	0	16	44	6	0	2	0	13	0	90
17:15	2	11	2	0	4	0	0	0	18	23	15	0	0	2	5	0	82
17:30	1	23	1	0	10	1	1	0	11	18	11	0	1	2	10	0	90
17:45	2	28	1	0	10	2	4	0	24	23	8	0	1	2	11	0	116
Total	6	69	4	0	25	3	5	0	69	108	40	0	4	6	39	0	378
18:00	0	31	3	0	3	1	2	0	20	24	2	0	1	2	10	0	99
18:15	0	7	1	0	3	1	0	0	13	12	2	0	1	0	4	0	44
Grand Total	9	117	9	0	31	6	7	0	136	175	46	0	8	8	81	0	633
Apprch %	6.7	86.7	6.7	0	70.5	13.6	15.9	0	38.1	49	12.9	0	8.2	8.2	83.5	0	
Total %	1.4	18.5	1.4	0	4.9	0.9	1.1	0	21.5	27.6	7.3	0	1.3	1.3	12.8	0	

# LSC Transportation Consultants, Inc.

545 E Pikes Peak Ave, Suite 210

Colorado Springs, CO 80905

719-633-2868

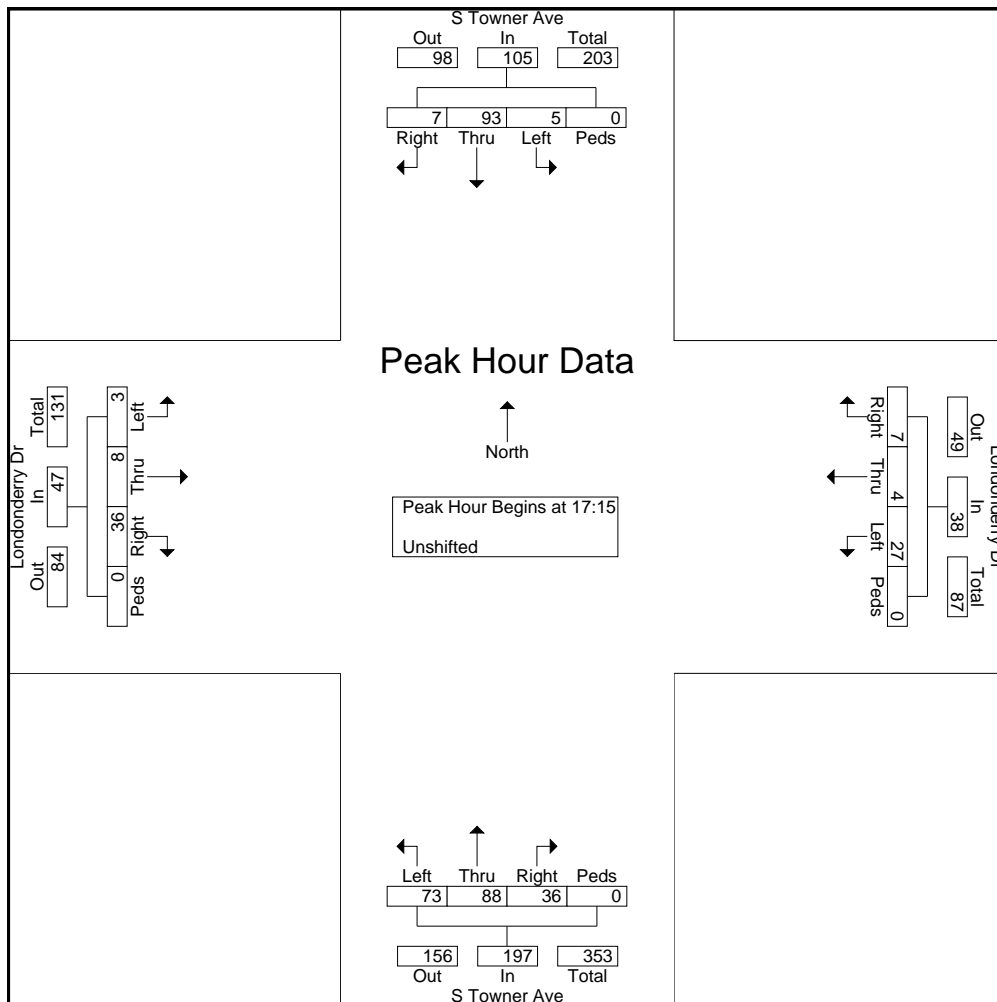
File Name : S Towner Ave - Londonderry Dr PM

Site Code : 00184630

Start Date : 9/25/2018

Page No : 2

Start Time	S Towner Ave Southbound					Londonderry Dr Westbound					S Towner Ave Northbound					Londonderry Dr Eastbound					Int. Total
	Left	Thru	Right	Peds	App. Total	Left	Thru	Right	Peds	App. Total	Left	Thru	Right	Peds	App. Total	Left	Thru	Right	Peds	App. Total	
Peak Hour Analysis From 16:30 to 18:15 - Peak 1 of 1																					
Peak Hour for Entire Intersection Begins at 17:15																					
17:15	2	11	2	0	15	4	0	0	0	4	18	23	15	0	56	0	2	5	0	7	82
17:30	1	23	1	0	25	10	1	1	0	12	11	18	11	0	40	1	2	10	0	13	90
17:45	2	28	1	0	31	10	2	4	0	16	24	23	8	0	55	1	2	11	0	14	116
18:00	0	31	3	0	34	3	1	2	0	6	20	24	2	0	46	1	2	10	0	13	99
Total Volume	5	93	7	0	105	27	4	7	0	38	73	88	36	0	197	3	8	36	0	47	387
% App. Total	4.8	88.6	6.7	0		71.1	10.5	18.4	0		37.1	44.7	18.3	0		6.4	17	76.6	0		
PHF	.625	.750	.583	.000	.772	.675	.500	.438	.000	.594	.760	.917	.600	.000	.879	.750	1.0	.818	.000	.839	.834



# LSC Transportation Consultants, Inc.

545 E Pikes Peak Ave, Suite 210

Colorado Springs, CO 80905

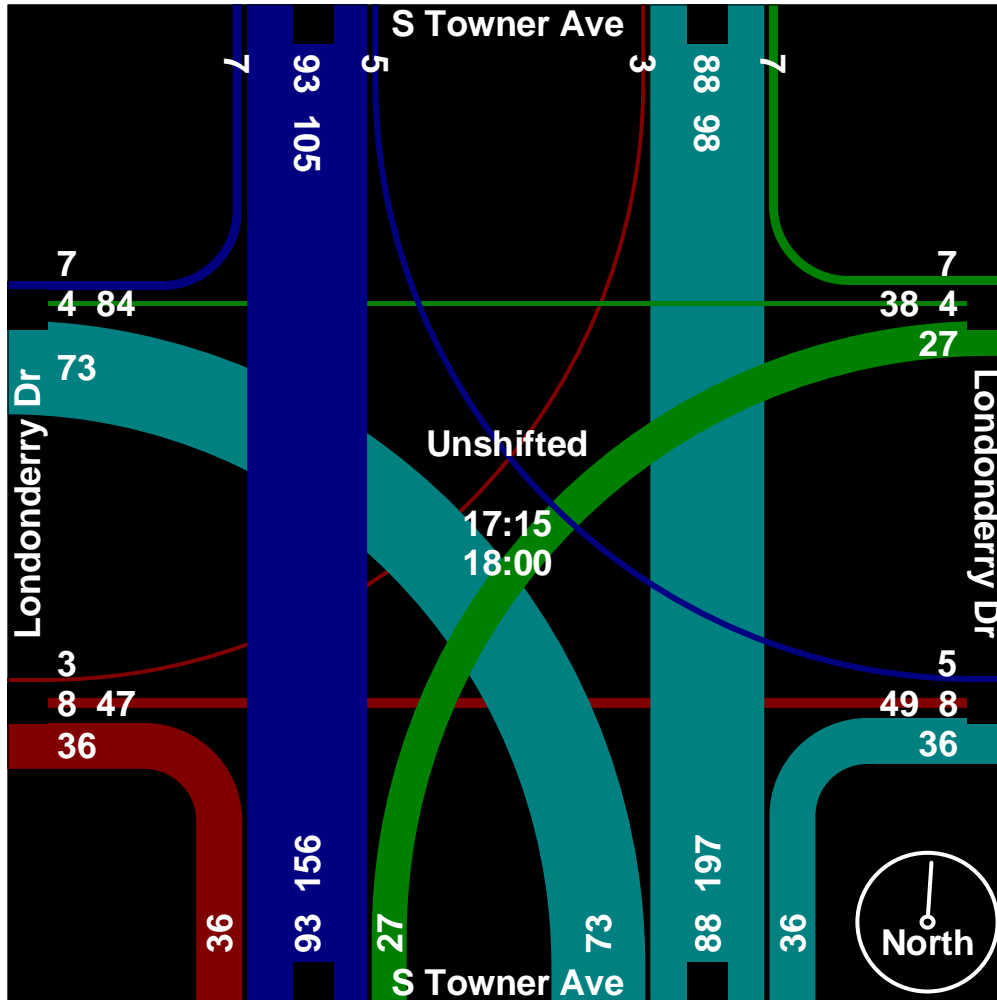
719-633-2868

File Name : S Towner Ave - Londonderry Dr PM

Site Code : 00184630

Start Date : 9/25/2018

Page No : 3



# LSC Transportation Consultants, Inc.

545 E Pikes Peak Ave, Suite 210

Colorado Springs, CO 80905

719-633-2868

File Name : Stapleton Dr - Towner Ave AM

Site Code : 184390

Start Date : 05/03/2018

Page No : 1

### Groups Printed- Unshifted

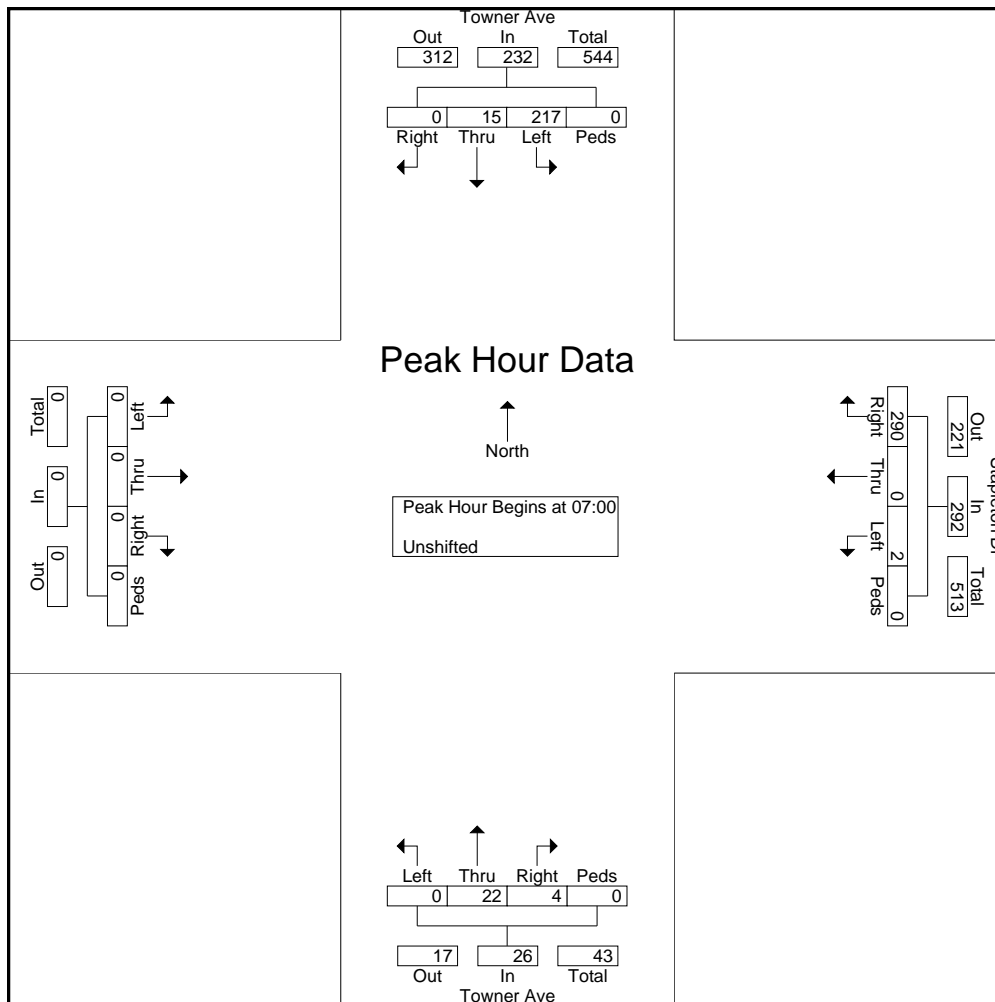
Start Time	Towner Ave Southbound					Stapleton Dr Westbound					Towner Ave Northbound					Eastbound					Int. Total
	Left	Thru	Right	Peds	App. Total	Left	Thru	Right	Peds	App. Total	Left	Thru	Right	Peds	App. Total	Left	Thru	Right	Peds	App. Total	
06:30	22	1	0	0	23	1	0	16	0	17	0	2	1	0	3	0	0	0	0	0	43
06:45	26	1	0	0	27	0	0	33	0	33	0	2	1	0	3	0	1	0	0	1	64
Total	48	2	0	0	50	1	0	49	0	50	0	4	2	0	6	0	1	0	0	1	107
07:00	48	5	0	0	53	0	0	47	0	47	0	5	0	0	5	0	0	0	0	0	105
07:15	65	4	0	0	69	0	0	93	0	93	0	6	2	0	8	0	0	0	0	0	170
07:30	59	4	0	0	63	1	0	119	0	120	0	8	1	0	9	0	0	0	0	0	192
07:45	45	2	0	0	47	1	0	31	0	32	0	3	1	0	4	0	0	0	0	0	83
Total	217	15	0	0	232	2	0	290	0	292	0	22	4	0	26	0	0	0	0	0	550
08:00	22	1	0	0	23	1	0	20	0	21	0	2	1	0	3	0	0	0	0	0	47
08:15	16	2	0	0	18	0	0	12	0	12	0	1	0	0	1	0	0	0	0	0	31

# LSC Transportation Consultants, Inc.

545 E Pikes Peak Ave, Suite 210  
 Colorado Springs, CO 80905  
 719-633-2868

File Name : Stapleton Dr - Towner Ave AM  
 Site Code : 184390  
 Start Date : 05/03/2018  
 Page No : 3

Start Time	Towner Ave Southbound					Stapleton Dr Westbound					Towner Ave Northbound					Eastbound					Int. Total
	Left	Thru	Right	Peds	App. Total	Left	Thru	Right	Peds	App. Total	Left	Thru	Right	Peds	App. Total	Left	Thru	Right	Peds	App. Total	
Peak Hour Analysis From 06:30 to 08:15 - Peak 1 of 1																					
Peak Hour for Entire Intersection Begins at 07:00																					
07:00	48	5	0	0	53	0	0	47	0	47	0	5	0	0	5	0	0	0	0	0	105
07:15	65	4	0	0	69	0	0	93	0	93	0	6	2	0	8	0	0	0	0	0	170
07:30	59	4	0	0	63	1	0	119	0	120	0	8	1	0	9	0	0	0	0	0	192
07:45	45	2	0	0	47	1	0	31	0	32	0	3	1	0	4	0	0	0	0	0	83
Total Volume	217	15	0	0	232	2	0	290	0	292	0	22	4	0	26	0	0	0	0	0	550
% App. Total	93.5	6.5	0	0		0.7	0	99.3	0		0	84.6	15.4	0		0	0	0	0		
PHF	.835	.750	.000	.000	.841	.500	.000	.609	.000	.608	.000	.688	.500	.000	.722	.000	.000	.000	.000	.000	.716







# LSC Transportation Consultants, Inc.

545 E Pikes Peak Ave, Suite 210  
 Colorado Springs, CO 80905  
 719-633-2868

File Name : Stapleton Dr - Towner Ave PM

Site Code : 184390

Start Date : 05/03/2018

Page No : 1

Start Time	Towner ave Southbound					Stapleton Dr Westbound					Towner ave Northbound					Eastbound					Int. Total	
	Left	Thru	Right	Peds	App. Total	Left	Thru	Right	Peds	App. Total	Left	Thru	Right	Peds	App. Total	Left	Thru	Right	Peds	App. Total		
Peak Hour Analysis From 16:00 to 17:45 - Peak 1 of 1																						
Peak Hour for Entire Intersection Begins at 16:15																						
16:15	16	2	0	0	18	0	0	34	0	34	0	1	1	0	2	0	0	0	0	0	0	54
16:30	12	0	0	0	12	1	0	26	0	27	0	3	0	0	3	0	0	0	0	0	0	42
16:45	17	0	0	0	17	2	0	25	0	27	0	1	0	0	1	0	0	0	0	0	0	45
17:00	29	2	0	0	31	1	0	18	0	19	0	1	1	0	2	0	0	0	0	0	0	52
Total Volume	74	4	0	0	78	4	0	103	0	107	0	6	2	0	8	0	0	0	0	0	0	193
% App. Total	94.9	5.1	0	0		3.7	0	96.3	0		0	75	25	0		0	0	0	0	0		
PHF	.638	.500	.000	.000	.629	.500	.000	.757	.000	.787	.000	.500	.500	.000	.667	.000	.000	.000	.000	.000	.000	.894

