

**STORMWATER MANAGEMENT PLAN**  
**FOR CREEKSIDE SOUTH AT LORSON RANCH**  
**FILING No. 2**

ACCEPTED for FILE  
Engineering Review

10/13/2022 3:15:39 PM

*dsdnijkamp*

EPC Planning & Community  
Development Department

**PUDSP 22-003**

Stormwater Permit # \_

Certification # \_\_\_\_\_

**Owner/Developer:**

Love In Action / Lorson, LLC  
212 N. Wahsatch Avenue, Suite 301  
Colorado Springs, Colorado 80903  
Contact: Jeff Mark  
(719) 635-3200

**SWMP Administrator/  
Qualified Stormwater Manager:**

TNT Landscaping, Inc  
Trevor Terrill  
4795 Mark Dabling Rd.  
Colorado Springs, Colorado 80918  
(719) 659-5619

**SWMP Preparer:**

Core Engineering Group, LLC  
Richard L. Schindler, P.E.  
15004 1<sup>st</sup> Avenue S  
Burnsville, MN 55306  
719-659-7800

**Contractor:**

Dwire Earthmoving  
6799 Bismark Road, Suite C  
Colorado Springs, CO 50922  
Contact: Wade Fothergill  
(719) 660-1058

**SWMP Location**

On-site (copy) and Lorson, LLC (original)



---

**TABLE OF CONTENTS**

---

## TABLE OF CONTENTS

## SWMP REPORT REVISION LOG

1.0 INTRODUCTION	1
2.0 SEQUENCE OF MAJOR ACTIVITIES	3
3.0 PRE-DEVELOPMENT CONDITIONS	4
4.0 DEVELOPED CONDITIONS	5
5.0 POTENTIAL SOURCES OF POLLUTION AND CONTROL STRATEGIES	6
6.0 BEST MANAGEMENT PRACTICES	9
7.0 SPILL PREVENTION PLAN	13
8.0 INSPECTIONS	15
9.0 RECORDS MANAGEMENT	16
10.0 FINAL STABILIZATION	17

**APPENDIX A: VICINITY MAP****APPENDIX B: Erosion Control Plans .....**

- EXHIBIT 1: CREEKSIDE SOUTH AT LORSON RANCH FILING NO. 2 EARLY GRADING AND EROSION CONTROL PLANS, DATED AUG 2022 BY CORE ENGINEERING GROUP

**APPENDIX C: STORMWATER INSPECTION REPORTS (BY REFERENCE ONLY  
NOT ATTACHED)****APPENDIX D: SPILL REPORT FORM****APPENDIX E: RECORD OF STABILIZATION AND CONSTRUCTION ACTIVITY DATES****APPENDIX F: FEDERAL, STATE, OR LOCAL STORM WATER OR OTHER  
ENVIRONMENTAL INSPECTOR SITE VISIT LOG****APPENDIX G: GENERAL PERMIT AND APPLICATION**



---

## 1.0 INTRODUCTION

---

**Creekside South at Lorson Ranch Filing No. 2** consists of 38 residential lots and several tracts of land for a total site area of 6.009 acres. The site is currently farm and ranching land within Lorson Ranch.

Murray Fountain, LLC is the Owner and Lorson, LLC is the overall developer and will construct major infrastructure (grading, roads, utilities, etc.) to serve the entire site. This Stormwater Management Plan (SWMP) will only cover construction activities that are provided as the overall developer. As the Lorson Ranch development progresses, this SWMP plan may need to be updated to reflect the revised scope of infrastructure.

### Site Description:

The site is located east of the East Tributary of Jimmy Camp Creek and south of Lorson Boulevard at Trappe Drive. The nearest major intersection is Lorson Boulevard and Trappe Drive. The major infrastructure for **Creekside South at Lorson Ranch Filing No. 2** includes but is not limited to construction of residential streets, offsite/onsite utilities, and grading the site for residential lots. Detention/Water quality for this development is located in two existing ponds (Pond E2, Pond D2) constructed as part of previous developments within Lorson Ranch. These ponds will treat and detain stormwater runoff prior to discharging into west into the East Tributary of Jimmy Camp Creek.

The legal description for **Creekside South at Lorson Ranch Filing No. 2** is:

Tract A, Creekside South at Lorson Ranch Filing No. 1 as recorded in  
Reception No. 221714746)

---

## 2.0 SEQUENCE OF MAJOR ACTIVITIES – Exhibit 1 Construction

---

The anticipated date for beginning construction activities is October, 2022 and will be complete in August, 2023. Implementation of the storm water management plan should be in place prior to initiating construction activities. Infrastructure for all residential lots will be installed in one phase. The anticipated sequence of construction is as follows:

Initial: (October, 2022):

1. Installation of perimeter erosion control measures as shown on Exhibit 1.
2. Vehicle Tracking Control Pads
3. Inlet Protection on existing inlets

Interim Stage (Nov 2022- May, 2023)

4. Site Clearing/Grubbing and topsoil stockpiling.
5. Rough Grade Site
6. Construct temporary sediment traps as construction progresses
7. Construct underground water/sewer/storm.
8. Construct curb/gutter and pavement.

Final: (May, 2023 to August, 2023)

9. Final stabilize areas outside of ROW.
10. Construct gas/electric/cable/phone in the ROW areas.

11. Final stabilize ROW.
12. Final erosion control measures as areas are completed
13. Remove construction BMP's

---

### 3.0 PRE-DEVELOPMENT CONDITIONS

---

According to the current FEMA Flood Insurance Rate Map (FIRM) number 08041CO957 G, this site is not located within the 100-year floodplain. See Appendix A.

Existing Vegetation:

The site is currently undeveloped and has been used as a pasture for many years. Ground cover is estimated at 65% density and will be visually verified in the field prior to groundbreaking activities.

Existing Slopes:

Existing slopes are around 1% that direct runoff northerly/southerly to existing storm sewer and detention ponds and the East Tributary.

Existing Drainage Patterns:

Pre-development drainage patterns generally flow north/south to existing storm sewer infrastructure/Detention Ponds constructed by Lorson Ranch. Drainage that flows west enters the East tributary of Jimmy Camp Creek.

Existing Soil Types:

The following table summarizes the characteristics of the soil type.

**Table 3.1: SCS Soils Survey**

Soil	Hydro. Group	Shrink/Swell Potential	Permeability	Surface Runoff Potential	Erosion Hazard
52-Manzanola Clay Loam	C	Moderate	Slow	Medium	Moderate
108-Wiley Silt Loam	B	Moderate	Moderate	Medium	Moderate

The existing soil types have a moderate potential for erosion which can be mitigated by employing appropriate downstream construction BMP's before/during/after construction to limit potential impacts to stormwater discharges. The potential impacts are sediment discharge into the existing offsite public storm sewer system and the proposed storm sewer system. Sediment should not be allowed to enter these existing and proposed facilities and can be mitigated by constructing small temporary sediment traps at low points and using existing ponds prior to discharge into the East Tributary. Based upon the location of the different soil types and type of construction, the contractor shall employ the most appropriate method of erosion control measures based on the

El Paso County/City of Colorado Springs Drainage Criteria Manual, Vol. 2 or as directed by the SWMP administrator or his representative.

More detailed soils information can be found in the SCS soils survey for El Paso County.

---

#### **4.0 DEVELOPED CONDITIONS**

---

The overall drainage concept for ***Creekside South at Lorson Ranch Filing No. 2*** is to direct the project area runoff north/south to existing storm sewer which flows into existing ponds located in Lorson Ranch. Stormwater Quality and detention will be provided in the two existing ponds prior to discharge into the East Tributary of Jimmy Camp Creek. The contractor will be responsible for any re-excavation of sediment and debris that collects in the basin depression required to ensure that the basin meets the design grades following construction. The storm lines shall also be cleaned and free of sediment once the site becomes stabilized.

There are no control measures owned/operated by another entity within this project site and disturbed area.

Proper erosion protection will be installed so no sediment enters the public storm sewer system or is discharged offsite.

##### Construction Site Estimates:

- Project Site: 6.009 acres
- Disturbed Area: 4.00 acres
  
- Percent Impervious before Construction: 0%
- Runoff Coefficient before Construction: 0.35 for undeveloped
- Ground Cover density prior to construction 65%
  
- Percent Impervious after Construction: 52%
- Runoff Coefficient after Construction: 0.55 for developed areas
- Final stabilization must be 70% of pre-construction density.

##### Receiving Waters:

- East Tributary of Jimmy Camp Creek
- This SWMP does not include any grading within the floodway of the East Tributary of Jimmy Camp Creek.
- Description: The creek channels are dry creek beds that flows water intermittently after significant rainfall events in the drainage basin.
- Description of Storm Sewer System: There is an existing storm sewer system in Trappe Drive, Lorson Boulevard, and Luneth Drive
- Description of impaired waters or waters subject to TMDLs: The site contains no impaired waters or waters subject to TMDLs.
- Description of unique features that are to be preserved: There are no known protected plant species within the project limits.
- Describe measures to protect these features: there are no known features to be protected.

Site Features and Sensitive Areas to be Protected:

This site is not located within (100-year floodplain) and contains no other sensitive areas including wetlands or endangered species and no grading will occur in the floodway of the creek.

Stream Crossings:

This site is located outside of (100-year floodplain) and there will be no stream crossings with this development.

---

## **5.0 POTENTIAL SOURCES OF POLLUTION AND CONTROL STRATEGIES**

---

Potential sources of sediment to stormwater runoff include earth moving and concrete activities associated with grading and landscaping.

Potential pollutants and sources, other than sediment, to stormwater runoff include Trash, debris, line transfer, Dewatering, fueling and equipment failure.

A dewatering permit is not anticipated with this project.

There are no asphalt or concrete batch plants proposed with this project.

Construction activities produce many different kinds of pollutants which may cause storm water contamination problems. Grading activities remove rocks, vegetation and other erosion controlling surfaces, resulting in the exposure of underlying soil to the elements. Because the soil surface is unprotected, soil and sand particles are easily picked up by wind and/or washed away by rain or other water sources.

The following sections highlight the potential sources of pollution at the Project Site and list the “Best Management” strategies that will be used to prevent migration of pollution offsite. Chemical materials stored indoors or that have no reasonable chance of impacting storm water quality will not be discussed in this plan.

Materials of significance stored on the project site include:

- Sediment
- Concrete Washout
- Cement
- Trash & Debris
- Sanitary Wastes
- Fuels & Oils

### **5.1 Wind Erosion & Dust Control**

Pollutant: Sediment

Best Management Strategies:

- Daily inspections will occur for areas experiencing excessive winds, vehicle traffic, or precipitation events.
- Water trucks will spray down dust on the project Site as needed to not impact adjacent properties.
- Attention will be given to prevent the over use of water in dust control operations to minimize any muddying of the surface and possible sediment transportation.

## **5.2 Vehicular Transport**

Pollutant: Sediment Tracking

Best Management Strategies:

- Construct a stabilized construction entrance to provide ingress and egress of the site.
- Restrict access to the stabilized construction entrance.
- Fencing will be erected if problems with access control are evident.
- Maintain track out pads by fluffing up the rock material or by adding additional rock as needed.
- Inspect, sweep and clean adjacent streets where track out is evident.

## **5.3 Stockpiles**

Pollutant: Sediment

Best Management Strategies:

- Locate stockpiles clear of any water flow paths.
- Locate stockpiles within the property boundary.
- Stockpiles will have erosion control devices as needed installed around the base to prevent the migration of soil.
- Topsoil stock piles and disturbed portions of the site where construction activity temporarily ceases for at least 14 days will be stabilized with temporary seed and mulch no later than 14 days from the last construction activity in the area.

## **5.4 Grading, Trenching, Export/Import**

Pollutant: Sediment

Best management Strategies:

- Earth moving will be minimized by the engineering balancing of the site.
- Disturbed portions of the site where construction activity temporarily ceases for at least 14 days will be stabilized with temporary seed and mulch no later than 14 days from the last construction activity in the area.
- Seed bed preparation is not required if soil is in loose condition.
- Prior to seeding, fertilizer shall be applied to each acre to be stabilized in accordance with the manufacturer's specifications.
- If required seeding areas shall be mulched with straw to a uniformed cover. The straw mulch is to be tacked into place by a disk with blades set nearly straight.
- A site specific erosion control drawing has been developed showing the location of Best Management practices to be used during site construction.
- Where indicated on the erosion control plan, Best Management Practices will be installed.
- Material shall be in accordance with the plans and specifications and all construction shall be provided in accordance with the manufacturer's specifications.
- All BMP's will be inspected bi-weekly and cleaned/maintained as required.

## **5.5 Waste, Residual Concrete**

Pollutant: Concrete, paint, and Phosphoric Acid

Best Management Strategies:

- A cleanup and washout area will be designated and posted.
- Subcontractors will be instructed on the locations and importance of the washout and cleanup areas. No on-site disposal is allowed.

- Instruct subcontractors to remove waste for which proper onsite disposal facilities are not provided back to their own facilities for ultimate transport, storage & disposal.
- Subcontractors and subcontractor employees are held responsible for improper washout.

### **5.6 Sanitary Facilities, Trash Containers & Littering**

Pollutant: Bacteria, Ammonia, Trash

Best Management Strategies:

- Portable facilities will be regularly serviced to prevent excessive waste containment and overflow.
- All waste materials will be collected and stored in a container which will meet all local and any state solid waste management regulations.
- Trash dumpsters will be emptied prior to becoming 90% full or when debris control becomes an issue.
- Employees will be instructed on the importance of recycling and waste management, and will be held responsible for improper waste management.

### **5.7 Fueling, Hazardous Materials, Equipment Leakage, Fertilizer**

Pollutant: Petroleum Hydrocarbons, Ethylene Glycol, Sediment

Best Management Strategies:

- MSDS sheets will be maintained in the project trailer for all onsite materials
- All dry materials such as cement will be covered and protected from rain.
- Secondary containment will be provided for stored fuel, oil, paint and any material classified as hazardous.
- Subcontractors are responsible for hazardous waste removal back to their own facilities for ultimate transportation, storage and disposal.
- Supplies will be kept onsite as necessary to control any potential spill.
- Employees will be held responsible for any illegal dumping.
- Seals will be checked by a qualified professional on all equipment and containers containing significant materials that could contribute potential pollutants and will be replaced as necessary.
- Equipment will be inspected by a qualified professional.
- Drip pans will be available for minor leaks and during fueling operations.
- Fueling nozzles, gauges, hoses, seals, and emergency shutoff valves will be inspected for leaks prior to use.
- Under no circumstances during fueling will the fueling hose/nozzle be left unattended.
- Fertilizers used will be applied only in the minimum amounts recommended by soil tests.
- Once applied, fertilizers will be worked into the soil to limit exposure to storm water.
- Stored fertilizer will be protected from exposure to precipitation and storm water runoff.

### **5.8 Dewatering – not anticipated to be necessary. This shown for information only**

Pollutant: Sediment, Oil and/or Grease and Phosphoric Acid

Best Management Strategies:

- All dewatering will be filtered through rock and/or woven geo mesh fabric.
- All dewatering will be tested for Pollutants per state guidelines weekly

### **5.9 Concrete and Asphalt Batch Plant** This shown for information only

There are no existing batch plants located on this project site and there are no proposed batch plants in the future.



---

## **6.0 BEST MANAGEMENT PRACTICES (BMP's)**

---

Also refer to attached Erosion and Sediment Control notes and plans included in the site plans

### **6.1 – Erosion and Sediment Control BMP's**

#### **6.1.1 Minimize Disturbed Area and Protect Natural Features and Soil**

All work will occur inside the limits of construction per the erosion Control Site Plan. See Exhibit 1.

#### **6.1.2 Phase Construction Activity**

The sequence for the installation and removal of erosion and sediment control measures is as follows:

1. Installation of perimeter erosion control measures as shown on Exhibit 1.
2. Site Clearing/Grubbing and topsoil stockpiling.
3. Construct temp sediment traps
4. Final grading of street ROW's and other areas
5. Construct underground water/sewer/storm.
6. Construct curb/gutter and pavement.
7. Final stabilize areas outside of ROW.
8. Construct gas/electric/cable/phone in the ROW areas.
9. Final stabilize ROW.
10. Final erosion control measures as areas are completed

#### **6.1.3 Control Stormwater Flowing onto and through the Project**

Narrative:

There is no offsite stormwater flowing onto this project. Temporary sediment traps and a proposed storm sewer system will convey on-site stormwater throughout the site.

#### **6.1.4 Stabilize Soils**

No disturbed area which is not actively being worked shall remain denuded for more than 14 calendar days unless otherwise authorized by the director. Temporary cover by seeding or mulching should be provided on areas which will be exposed for a period greater than 14 days before permanent stabilization can be achieved. Permanent cover should be provided on all areas as soon as possible, by means of seeding and mulching, straw or hay mulch is required. All soil stock piles and borrow areas must protected with silt fence within 14 days after grading. All slopes within the project limits that are found to be eroding excessively within two years of permanent stabilization shall be provided additional slope stabilization methods such as seeding and mulching.

Water is to be used for dust control. The Contractor will prevent the escape of this water and any sediment it may carry from the construction site.

#### **6.1.5 Protect Slopes**

Temporary stabilization will include the installation of silt fences on level contours spaces at 10-20 foot intervals. Slopes will be seeded and covered with hay, straw or erosion control blankets

on slopes greater than 3:1 as needed to provide for temporary stabilization until vegetation is permanently established.

All slopes within the project limits that are found to be eroding excessively within two years of permanent stabilization shall be provided additional slope stabilization methods such as seeding and mulching. Where slopes are steeper than 3:1 erosion control blankets (per specification requirements) will be utilized for final stabilization.

#### **6.1.6 Protect Storm Drain Inlets**

Inlet protection will be installed as soon as storm drain inlets are installed and before land-disturbance activities begin in areas with existing storm drain systems.

At the Contractor's discretion, additional temporary erosion control practices to include rock bags and sand bag barriers may be installed to prevent sediment movement. Inlet protection will include rock bags erosion logs curb inlet sediment filters where an overflow capacity is necessary to prevent excessive ponding in front of the curb inlet. Concrete block and wire screen inlet protection if used a detail will be included Appendix B prior to installation, will be used where heavy flows are expected and where an overflow capacity is necessary to prevent excessive ponding around the inlet.

Inlet protection devices will be inspected and accumulated sediment will be removed as needed.

#### **6.1.7 Establish Perimeter Controls and Sediment Barriers**

Temporary stabilization will include the installation of silt fences on the downslope perimeter of project area. The silt fence will be trenched in on the uphill side 6 inches deep and 6 inches wide as detailed in the silt fence exhibit. Sediment will be removed when it reaches 1/3 the height of the fence. Silt fence will be inspected and replaced or repaired as needed.

#### **6.1.8 Retain Sediment On-Site**

Temporary sediment traps shall be installed to detain sediment laden runoff from small watersheds for a period long enough to allow sediment to settle before discharge into receiving waters. For small drainage locations smaller sediment traps should be used. At a minimum, silt fences, vegetative buffer strips or equivalent sediment controls are required for all down-slope boundaries (and for those side slope boundaries deemed appropriate as dictated by individual site conditions) of the construction. The use of a combination of sediment and erosion control measures in order to achieve maximum pollutant removal will be utilized. Sediment traps/basins will be checked regularly for sediment cleanout. Sediments shall be removed and the trap restored to its original dimensions when the sediment has accumulated to one half the design volume of the wet storage. Sediment shall be disposed in suitable areas and in such a manner that will not erode or cause sedimentation problems.

The gravel outlets will be checked regularly for sediment buildup which will prevent damage. If the gravel is clogged by sediment, it shall be removed and cleaned or replaced.

#### **6.1.9 Establish Stabilized Construction Exits**

The construction entrance will be established in the entry points of roads. The construction entrance will be at least 75 feet in length and approximately 12 feet wide and graded so runoff does not leave the site. The aggregate will be established at 8 inches thick on top of 4 inch minimum thick free draining material on top of geotextile and will consist of Type G dense graded material. A stabilized stone pad with a filter fabric under liner will be placed at points of vehicular ingress and egress.

### **6.1.10 Additional BMP's**

#### **BMP Schedule:**

All Sediment and Erosion control BMP's (detailed below and only on BMP site map and details if utilized onsite) will be installed prior to any excavation or demolition and will be coordinated with the construction schedule.

As construction changes and new temporary BMP's are needed to control sediment and erosion temporary BMP's will be installed within 24 hours of inspection report.

#### **Recommended BMP's:**

ALL RECOMMENDED BMP'S WILL BE INSTALLED PRIOR TO EXCAVATION NEAR ANY SENSITIVE AREAS.

**Culvert Inlet Protection** will be used to protect existing and new culvert inlets. Inlet Protection Detail will be included in Appendix before using onsite. Removal of this BMP will occur only after vegetation is established to a minimum of 70% pre construction coverage and after removal of BMP all sediment builds up will be removed and the area exposed shall be seeded.

**Silt Fence** is to be installed in sensitive areas to protect stream channels, pond, and overland runoff. On this site it will be used to protect runoff from the slip pits. See Silt Fence Detail. Removal of this BMP will occur only after vegetation is established to a minimum of 70% pre construction coverage and after removal of BMP all sediment builds up will be removed and the area exposed shall be seeded.

**Vehicle Tracking Control** is needed at the main construction entrance location. Vehicle tracking control shall be installed at the edge of the construction staging area where construction vehicles regularly exit onto existing asphalt road. If sediment tracking occurs it will be cleaned within 24 hours.

See Vehicle Tracking Control Detail in Appendix B. Removal of this BMP will occur only after project is substantially complete and is ready for seeding operations; the area will then be seeded per specification with the rest of the project.

**Check Dams** (rip rap) will be used to reduce storm water velocities in drainage channels during construction as a temporary measure until permanent stabilization can be created and vegetation has been established. Check Dam Detail will be included in the the Appendix before using onsite. Removal of this BMP will occur only after vegetation is established to a minimum of 70% pre construction coverage and after removal of BMP all sediment build-up will be removed and the area exposed shall be seeded.

**Portable Toilets:** Portable toilets are brought in from a service contractor and will be maintained in accordance with standard waste disposal practices using vacuum trucks and place on stable ground to minimize risk of spillage. All portable toilets will be kept a minimum of 50' from any state waters and a minimum of 10' from stormwater inlets. They shall be adequately staked and cleaned on a weekly basis. They will be inspected daily for spills.

**Waste Disposal:** If needed Roll offs will be utilized for standard construction waste. A qualified contractor will remove waste weekly and take to an appropriate dump site off this project.

#### **6.1.11 Permanent BMP'S:**

##### **Re-vegetation:**

During construction any disturbed area not being currently worked left dormant longer than 14 days will be re-vegetated per specification with native seed and mulched and crimped with weed free straw.

**Final Stabilization** will be considered complete when all disturbed areas have a minimum of 70% preconstruction coverage for the specification requirements. Then all temporary BMP's will be removed and the exposed areas left behind will be seeded.

Other permanent BMP's include Permanent Full Spectrum Detention/WQ Ponds D2 and E2 to treat storm runoff prior to entering the East Tributary of Jimmy Camp Creek. These ponds are existing and include concrete forebays, concrete low flow channels, and full spectrum outlet structures including water quality.

## **6.2 Good Housekeeping BMP'S**

### **6.2.1 Material Handling and Waste Management**

The site will use a private refuse collector that will remove litter twice weekly. No less than one litter receptacle will be present at the construction site. In the event that unusual items such as tanks, cylinders, unidentified containers, etc. which could contain potentially hazardous materials are discovered or disturbed, the Fire and Rescue services will be notified.

Litter and debris will be picked up and disposed of properly daily.

Temporary toilet facilities will be located 50 feet away from any storm drain inlets and all waters of the state.

### **6.2.2 Establish Proper Building Material Staging Areas**

A designated staging area will be used, location to be determined based on available space in the field and plans will be redlined. The staging area will be contained per SWMP guidelines. All Equipment and Materials will be brought into the site as needed.

### **6.2.3 Designate Washout Areas**

A concrete washout will be installed and will be placed more than 500 feet away from any waters of the state. The location will be field determined and documented.

### **6.2.4 Establish Proper Equipment/Vehicle Fueling and Maintenance Practices**

During construction the site will be exposed to operation and maintenance of construction equipment. The contractor shall be responsible for all activities such as fueling, oil changing, lubrication and repair which require use of petroleum products. Such products shall be transported to and from the site in special trucks equipped for that purpose. No waste petroleum products, rags, residue, or equipment parts shall be left on site. In the event of a spill or leak,

causing soil to be contaminated, that soil shall be excavated placed in sealed barrels and removed from the site for transport to an approved location for disposal.

See section 7 for the Spill Plan.

#### **6.2.5 Control Equipment/Vehicle Washing**

Washing any equipment will not be allowed on-site

#### **6.2.6 Any Additional BMPs**

There are no additional BMP's anticipated

#### **6.2.7 Allowable Non-Stormwater Discharge Management**

There are no visible natural springs or irrigation or other non-stormwater discharges anticipated to be encountered.

#### **6.2.8: SELECTING POST-CONSTRUCTION BMPs**

Post Construction BMPs. Re-vegetation including seeding, mulching and erosion control blanket, and WQ ponds for long-term stormwater quality will be final BMP's. Permanent stabilization will be achieved with 70% pre construction vegetative establishment.

---

### **7.0 SPILL PREVENTION AND CONTROL PLAN**

---

The SITE SUPERINTENDENT will act as the point of contact for any spill that occurs at this jobsite. The project manager will be responsible for implementation of prevention practices, spill containment / cleanup, worker training, reporting and complete documentation in the event of a spill. The ECO shall immediately notify the Owner, /Construction Manager, STATE and the Local Fire Department in addition to the legally required Federal, State, and Local reporting channels (including the National Response Center, 800.424.8802) if a reportable quantity is released to the environment

#### **7.1 SPILL PREVENTION BEST MANAGEMENT PRACTICES**

This section describes spill prevention methods Best Management Practices (BMP) that will be practiced to eliminate spills before they happen.

##### **7.1.a Equipment Staging and Maintenance**

Store and maintain equipment in a designated area Reduce the amount of hazardous materials and waste by substituting non-hazardous or less hazardous materials.  
Use secondary containment (drain pan) to catch spills when removing or changing fluids.  
Use proper equipment (pumps, funnels) to transfer fluids Keep spill kits readily accessible Check incoming vehicles for leaking oil and fluids.  
Transfer used fluids and oil filters to waste or recycling drums immediately following generation.  
Inspect equipment routinely for leaks and spills Repair equipment immediately, if necessary implement a preventative maintenance schedule for equipment and vehicles.

##### **7.1.b Fueling Area**

Perform fueling in designated fueling area minimum 50' away from federal waters  
Use secondary containment (drain pan) to catch spills

Use proper equipment (pumps, funnels) to transfer fluids  
 Keep spill kits readily accessible  
 Inspect fueling areas routinely for leaks and spills

**Hazardous Material Storage Areas**

Reduce the amount of hazardous materials by substituting non-hazardous or Less hazardous materials.

**7.1. c Hazardous Material Storage Areas**

Minimize the quantity of hazardous materials brought onsite  
 Store hazardous materials in a designated area away from drainage points.

**7.1. d Unexpected Contaminated Soil and Water**

- Investigate historical site use
- Perform all excavation activities carefully and only after the Owner/Construction Manager directed any activities

**7.2 SPILL CONTAINMENT METHODS**

The following discussion identifies the types of secondary containment that will be used in the event of a spill. Table 1 summarizes the containment methods for each potential source.

- **Equipment Staging and Maintenance Area.** An equipment leak from a fuel tank, equipment seal, or hydraulic line will be contained within a spill containment cell placed beneath all stationary potential leak sources. An undetected leak from parked equipment will be cleaned up using hand shovels and containerized in a 55-gallon steel drum for offsite disposal.
- **Fueling Area.** A small spill during fueling operations will be contained using fuel absorbent pads at the nozzle. The transfer of fuel into portable equipment will be performed using a funnel and/or hand pump and a spill pad used to absorb any incidental spills/drips. Any leaking tanks or drums will have fluids removed and transferred to another tank, drum, or container for the fluids. A spill response kit will be located near the fueling area or on the fuel truck for easy access. The spill response kit will include plastic sheeting, tarps, over pack drums, absorbent litter, and shovels.
- **Hazardous Material Storage Area.** A spill from containers or cans in a hazardous material storage area will be contained within the storage cabinet these materials are kept in.
- **Unexpected Contaminated Soil.** If contaminated soil is encountered during the project, the Owner/Construction Manager will be notified immediately. Small quantities of suspected contaminated soil will be placed on a 6-mil plastic liner and covered with 6-mil plastic. A soil berm or silt fence will be used to contain the stockpile and prevent migration of contaminated liquids in the soil.

**Table 1: Spill Prevention and Containment Methods**

Potential Spill Source	Potential Spill Source
Equipment Staging and Maintenance Area	Spill containment pad, spill kit, pumps, funnels
Fueling Area (site equipment only)	Spill containment pad, spill kit, pumps, funnels

Hazardous Material Staging Area	Spill containment pad, spill kit, pumps, funnels
Unexpected Contaminated Soil	Plastic liner, plastic cover, soil berm, hay bales, lined super sacks

### 7.3 SPILL COUNTERMEASURES

Every preventative measure shall be taken to keep contaminated or hazardous materials contained. If a release occurs, the following actions shall be taken:

1. **Stop the Spill:** The severity of a spill at the site is anticipated to be minimal as large containers/quantities of Hazardous Materials (HM) are not anticipated. The type of spill would occur while dispensing material at the HM storage facility and would likely be contained in secondary containment. Thus, the use spill kits or other available absorbent materials should stop the spill.
2. **Warn Others:** Notify co-workers and supervisory personnel of the release. Notify emergency responders if appropriate. For site personnel, an alarm system will consist of three one second blasts on an air horn sounded by the person discovering a spill or fire. In the event of any spill, the Superintendent and Project Manager shall be notified **if the spill is 5 gallons or more the STATE will be contacted along with the Fire Department.**
3. **Isolate the Area:** Prevent public access to the area and continue to minimize the spread of the material. Minimize personal exposure throughout emergency response actions.
4. **Containment:** A spill shall only be contained by trained personnel and if it is safe to do so. DO NOT PLACE YOURSELF IN DANGER. Attempt to extinguish a fire only if it is in the incipient stage; trash can size or smaller. For larger spills, wait for the arrival of emergency response personnel and provide directions to the location of the emergency.
5. **Complete a Spill and Incident Report:** For each spill of a Hazardous Material a spill and incident report shall be completed and submitted to the Owner/Construction Manager and if applicable to the Engineer and the State of Colorado Department of Public Health and Environment

---

## 8.0 INSPECTIONS

---

### 8.1 Inspections

Inspections will occur at least every 14 days and within 24 hours of a precipitation or snow melt event producing runoff, which from past experience this occurs with precipitation of 1/4 inch of rain or more. The primary site for tracking weather data and rainfall measurements will be taken from

Weather Underground and a rain gauge will be onsite for verification only.

#### 1. Inspection Personnel:

The contract Qualified Stormwater Manager will conduct the site inspections as mentioned above in Section 8.1. The Qualified Stormwater Manager will be sufficiently qualified for the required duties per ECM Appendix I.5.

#### 2. Inspection Schedule and Procedures:

The inspection schedule will be routinely accomplished every 14 days and after every storm event or snow melt for the entire site with all BMP's evaluated for performance and

need. Any BMP found to be ineffective will be re-accomplished or replaced with a new BMP to provide the level of protection needed. BMP's found to be no longer needed will be removed. Inspections will also be accomplished as soon as practical, but within 24 hours of the end of a precipitation or snow melt event causing surface erosion. The general procedures for correcting problems when they are identified will be to document the problem in the log and devise a solution utilizing all resources available to formulate BMP's that will correct the problem as soon as possible. A copy of the inspection report to be used for the site is attached. See Appendix.

### **8.2 Delegation of Authority**

#### **Duly Authorized Representative(s) or Position(s):**

Authorized representatives for the SWMP plan will be: Jeff Mark – Primary Contact  
Qualified Stormwater Manager – Trevor Terrill

### **8.3 Revisions to the SWMP**

The Qualified Stormwater Manager and/or the site superintendent have the authority to add/subtract/revise BMP's as necessary to accommodate stormwater flow and prevent runoff. However, the engineer should be notified when any major redirection of runoff, offsite runoff, pond modifications, or other substantial changes are made to this SWMP. Changes should be documented per Section 9.0.

---

## **9.0 RECORDKEEPING AND TRAINING**

---

### **9.1 Recordkeeping**

- Records will be retained for a minimum period of at least 3 years after the permit is terminated.
- Major activities will start on 10/01/2022:
- Date(s) when construction activities permanently cease on a portion of the site: 8/2023
- Date(s) when an area is either temporarily or permanently stabilized: 7/2023
- All inspection logs must be signed by a qualified stormwater manager

### **9.2 Changes to the SWMP**

Any changes will be referenced in APPENDIX. See Section 8.3 for authority to change the SWMP. The SWMP should be viewed as a “living document” that is continuously being reviewed and modified as a part of the overall process of evaluating and managing stormwater quality issues at the site. The Qualified Stormwater Manager shall amend the SWMP when there is a change in design, construction, operation or maintenance of the site which would require the implementation of new or revised BMPs or if the SWMP proves to be ineffective in achieving the general objectives of controlling pollutants in stormwater discharges associated with construction activity or when BMPs are no longer necessary and are removed

### **9.3 Training**

Individual(s) Responsible for Training:

All personnel on site will trained on the site specific SWMP requirements to be conducted by the Qualified Stormwater Manager and/or the site superintendent.



#### **9.4 SWMP Location**

The on-site SWMP will be located at the SE corner of Fontaine Boulevard and Marksheffel Road. All signed inspection logs will be kept on-site with the SWMP.

---

### **10.0 FINAL STABILIZATION**

---

Final stabilization will be accomplished by contractors to re-vegetate the area of disturbance per the approved plans and specifications. Final stabilization will include permanent seeding/mulching of disturbed areas, sediment forebays, erosion control blankets, turf reinforcement mats, and permanent BMP's.

Once 70% of the pre-development vegetative cover has been established and has been accepted, temporary BMP's will be removed and the permit will be terminated and filed.

Long term stormwater quality will be achieved by adjacent existing full spectrum detention ponds with WQ outlet structures. If sediment and debris has collected, it must be excavated/removed to meet design grades. In addition, storm lines shall be clean and free from sediment once the site has been stabilized.

Final stabilization is anticipated to be completed in August, 2023

This project does not rely on control measures that are owned/maintained by another entity.

## **APPENDIX A**

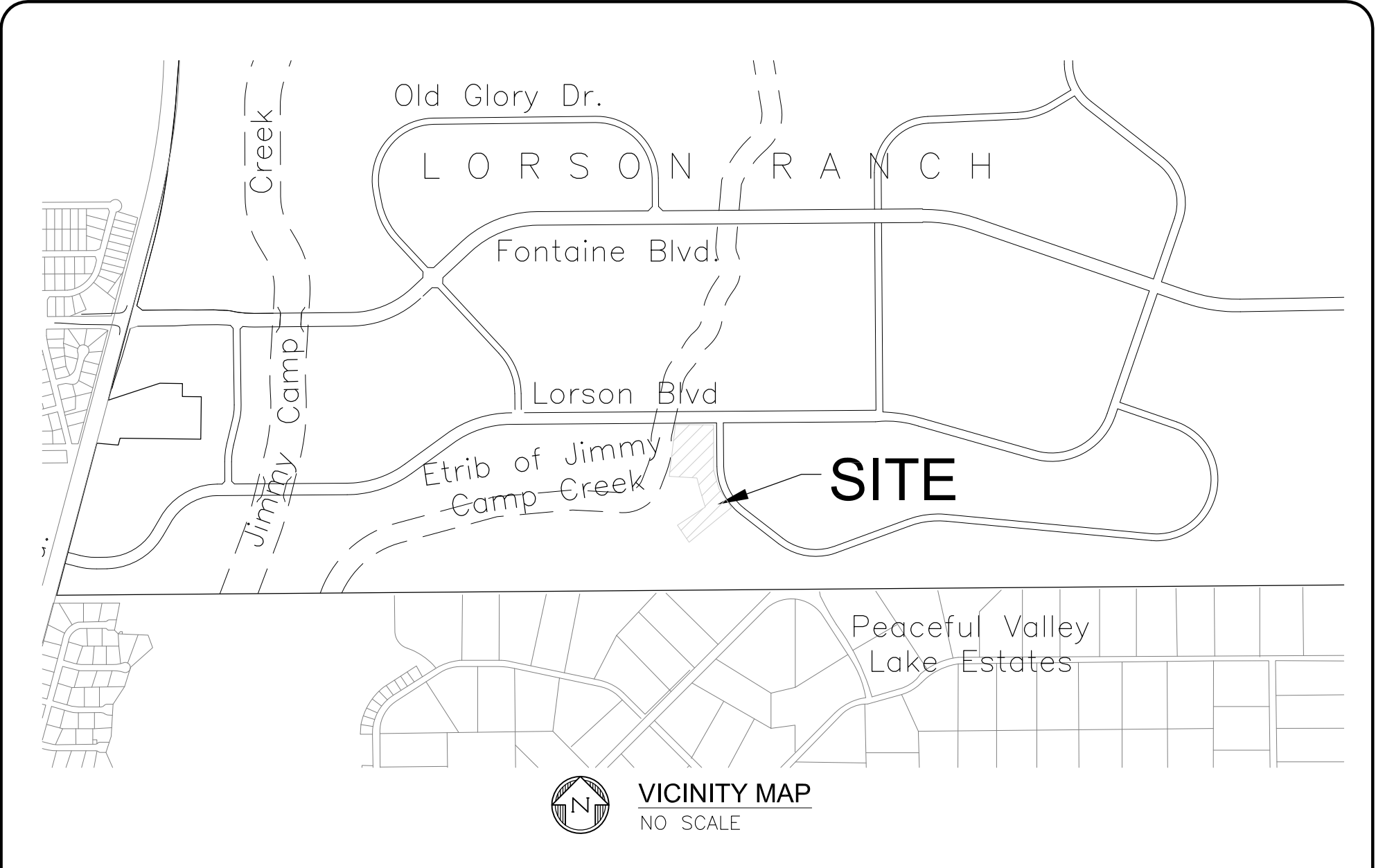

**VICINITY MAP**  
NO SCALE



**CORE**  
ENGINEERING GROUP

15004 1ST AVE. S.  
BURNSVILLE, MN 55306  
PH: 719.570.1100

CONTACT: RICHARD L. SCHINDLER, P.E.  
EMAIL: Rich@ceg1.com

**CREEKSIDE SOUTH AT LORSON RANCH FIL. NO. 2**  
**VICINITY MAP**

SCALE:  
NTS

DATE:  
MAY, 2022

FIGURE NO.  
--

**APPENDIX B**

**EROSION CONTROL PLANS**

PRELIMINARY SITE GRADING CONSTRUCTION PLANS  
FOR  
**CREEKSIDE SOUTH AT LORSON RANCH FIL. NO. 2**  
EARLY OVERLOT GRADING / EROSION CONTROL PLANS



**Know what's below.  
Call before you dig.**

CALL 2-BUSINESS DAYS IN ADVANCE  
BEFORE YOU DIG, GRADE OR  
EXCAVATE FOR THE MARKING OF  
UNDERGROUND MEMBER UTILITIES

SHEET INDEX	
SHEET NO.	SHEET DESCRIPTION
C0.1	COVER SHEET
C0.2	NOTES (GENERAL, GRADING, EROSION CONTROL)
C0.3	TYPICAL SECTIONS
C4.1	GRADING AND EROSION CONTROL PLAN
C12.1 ~ C12.4	DETAILS



VICINITY MAP  
NO SCALE

**DEVELOPER'S STATEMENT**

I, THE OWNER/DEVELOPER HAVE READ AND WILL COMPLY WITH THE REQUIREMENTS OF THE GRADING AND EROSION CONTROL PLAN.

Lorson, LLC  
AUG 24, 2022  
DATE

**CONSTRUCTION APPROVAL**

COUNTY PLAN REVIEW IS PROVIDED ONLY FOR GENERAL CONFORMANCE WITH COUNTY DESIGN CRITERIA. THE COUNTY IS NOT RESPONSIBLE FOR THE ACCURACY AND ADEQUACY OF THE DESIGN, DIMENSIONS, AND/OR ELEVATIONS WHICH SHALL BE CONFIRMED AT THE JOB SITE. THE COUNTY THROUGH THE APPROVAL OF THIS DOCUMENT ASSUMES NO RESPONSIBILITY FOR COMPLETENESS AND/OR ACCURACY OF THIS DOCUMENT. FILED IN ACCORDANCE WITH THE REQUIREMENTS OF THE EL PASO COUNTY LAND DEVELOPMENT CODE, DRAINAGE CRITERIA MANUAL VOLUMES 1 AND 2, AND ENGINEERING CRITERIA MANUAL, AS AMENDED.

IN ACCORDANCE WITH ECM SECTION 1.12, THESE CONSTRUCTION DOCUMENTS WILL BE VALID FOR CONSTRUCTION FOR A PERIOD OF 2 YEARS FROM THE DATE SIGNED BY THE EL PASO COUNTY ENGINEER. IF CONSTRUCTION HAS NOT STARTED WITHIN THOSE 2 YEARS, THE PLANS WILL NEED TO BE RESUBMITTED FOR APPROVAL, INCLUDING PAYMENT OF REVIEW FEES AT THE PLANNING AND COMMUNITY DEVELOPMENT DIRECTOR'S DISCRETION.

JOSHUA PALMER, P.E., COUNTY ENGINEER/ECM ADMINISTRATOR  
DATE

**ENGINEER'S APPROVAL**

THIS GRADING AND EROSION CONTROL PLAN WAS PREPARED UNDER MY DIRECTION AND SUPERVISION AND IS CORRECT TO THE BEST OF MY KNOWLEDGE AND BELIEF. SAID PLAN HAS BEEN PREPARED ACCORDING TO THE CRITERIA ESTABLISHED BY THE COUNTY FOR GRADING AND EROSION CONTROL PLANS. I ACCEPT RESPONSIBILITY FOR ANY LIABILITY CAUSED BY NEGLIGENT ACTS OR OMISSIONS ON MY PART IN PREPARING THIS PLAN



RICHARD L. SCHINDLER, P.E. # 33997  
FOR AND ON BEHALF OF CORE ENGINEERING GROUP

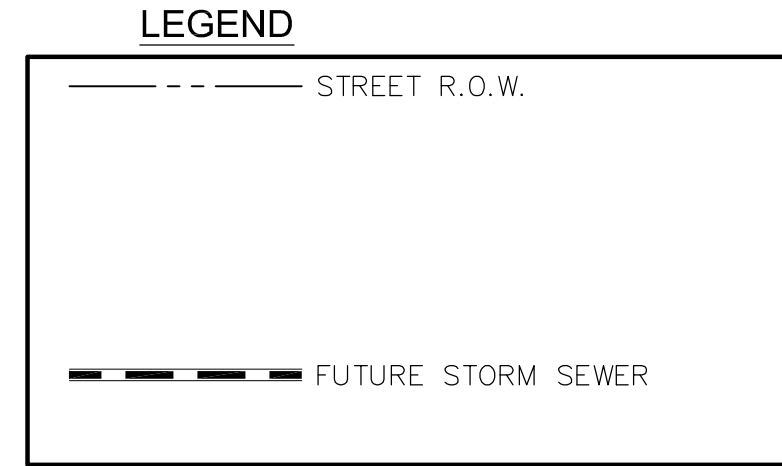

**WATER / SANITARY**  
WIDEFIELD WATER AND SANITATION DISTRICT  
8495 FONTAINE BLVD.  
COLORADO SPRINGS, CO 80925  
719-390-7111

**CABLE**  
COMCAST  
P.O. BOX 173838  
DENVER, CO 80217  
970-641-4774

**ELECTRIC**  
MOUNTAIN VIEW ELECTRIC  
11140 E. WOODMEN RD.  
COLORADO SPRINGS, CO 80831  
719-495-2283

**SECURITY FIRE PROTECTION DISTRICT**  
400 SECURITY BOULEVARD  
SECURITY, CO 80911  
719-392-7121

PREPARED FOR:  
**LORSON, LLC**  
N. WAHSATCH AVE., SUITE 301  
COLORADO SPRINGS, CO 80903  
719-635-3200  
CONTACT: JEFF MARK

PREPARED BY:  
**CORE ENGINEERING GROUP**  
15004 1ST AVENUE S.  
BURNSVILLE, MN 55306  
719-570-1100  
CONTACT: RICHARD L. SCHINDLER P.E.

**TELEPHONE**  
CENTURYLINK  
7925 INDUSTRY ROAD  
COLORADO SPRINGS, CO 80939  
719-278-4651

**GAS**  
BLACK HILLS ENGERGY  
7060 ALLEGRE ST.  
FOUNTAIN, CO 80817  
719-393-6639

**EL PASO COUNTY PLANNING AND COMMUNITY DEVELOPMENT**  
2880 INTERNATIONAL CIRCLE  
COLORADO SPRINGS, CO 80910  
719-520-6300

**BASIS OF BEARING**

BEARINGS ARE BASED ON THE SOUTH LINE OF THE NORTH HALF OF SECTION 23, TOWNSHIP 15 SOUTH, RANGE 65 WEST OF THE 6TH PRINCIPAL MERIDIAN AS BEING SOUTH 8941'52" WEST. THE EAST QUARTER CORNER OF SAID SECTION 23 IS A FOUND 3-1/2" ALUMINUM CAP MONUMENT AND THE WEST QUARTER CORNER OF SAID SECTION 23 IS A FOUND 2-1/2" ALUMINUM CAP MONUMENT

**BENCHMARK**

FIMS MONUMENT F204 LOCATED AT THE NORTHWEST CORNER OF FONTAINE BLVD AND COTTONWOOD GROVE DR. ELEVATION 5724.072 (N.G.V.D. 29)

**TRAFFIC CONTROL NOTE**

THE CONTRACTOR SHALL PROVIDE ALL TRAFFIC CONTROL DEVICES AND MONITORING NECESSARY TO SAFELY COMPLETE THE WORK SHOWN IN THESE CONSTRUCTION DOCUMENTS IN CONFORMANCE WITH M.U.T.C.D. GUIDELINES. THE CONTRACTOR SHALL COMPLETE ALL NECESSARY WORK FOR PLAN REVIEW, PERMITS AND PROCESSING. TRAFFIC CONTROL WILL NOT BE PAID SEPARATELY BUT IS INCLUDED IN THE COST OF THE PROJECT.

**CORE ENGINEERING GROUP**  
15004 1ST AVENUE S.  
BURNSVILLE, MN 55306  
PH: 719.570.1100  
CONTACT: RICHARD L. SCHINDLER, P.E.  
EMAIL: Rich@cog1.com

DATE  
DESCRIPTION  
NO.  
PREPARED FOR:  
**LORSON, LLC**  
212 N. WAHSATCH AVE, SUITE 301  
COLORADO SPRINGS, COLORADO 80903  
CONTACT: JEFF MARK  
PROJECT:  
**CREEKSIDE SOUTH AT LORSON RANCH 2**  
LORSON BLVD. TRAPPE DR. OR  
LORSON BLVD. TRAPPE DR.  
COLORADO SPRINGS, COLORADO

DRAWN: RLS  
DESIGNED: RLS  
CHECKED: RLS

**COVER SHEET  
EARLY GRADING AND  
EROSION CONTROL PLAN**

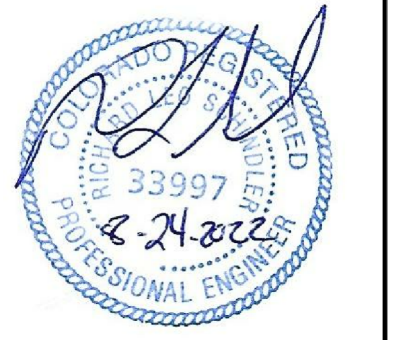

DATE:  
AUG 24, 2022  
PROJECT NO.  
100.069  
SHEET NUMBER  
**C0.1**  
TOTAL SHEETS: 8

**PUD/SP 22-003**



**CONSTRUCTION NOTES**

- ALL WORK SHALL COMPLY WITH THE CODES AND POLICIES FOR EL PASO COUNTY.
- EXISTING TOPOGRAPHIC INFORMATION SHOWN ON THIS GRADING PLAN WAS OBTAINED FROM AERIAL CONTOURS AND PREVIOUS CONSTRUCTION DOCUMENTS. THE CONTRACTOR SHALL BE RESPONSIBLE TO EXAMINE THE SITE AND BE FAMILIAR WITH THE EXISTING CONDITIONS.
- DEPTH OF MOISTURE-DENSITY CONTROL FOR THIS PROJECT SHALL BE AS FOLLOWS:  
BASE OF ALL CUTS AND FILLS - 12 INCHES,  
FULL DEPTH OF ALL EMBANKMENTS
- THE CONTRACTOR IS RESPONSIBLE FOR THE RE-ESTABLISHMENT OF ALL SURVEY MONUMENTS DISTURBED WITHIN THE PROJECT LIMITS.
- THE CONTRACTOR SHALL PROTECT ALL WORK AREAS AND FACILITIES FROM FLOODING AT ALL TIMES. AREAS AND FACILITIES SUBJECTED TO FLOODING, REGARDLESS OF THE SOURCE OF WATER, SHALL BE PROMPTLY DEWATERED AND RESTORED.
- PRIOR TO PAVING OPERATIONS, THE ENTIRE SUBGRADE SHALL BE PROOF-ROLLED WITH A LOADED 988 FRONT-END LOADER OR SIMILAR HEAVY RUBBER Tired VEHICLE (GVW OF 50,000 POUNDS WITH 18 KIP PER AXLE AT TIRE PRESSURES OF 90 PSI) TO DETECT ANY SOFT OR LOOSE AREAS. IN AREAS WHERE SOFT OR LOOSE SOILS, PUMPING OR EXCESSIVE MOVEMENT IS OBSERVED, THE EXPOSED MATERIALS SHALL BE OVER-EXCAVATED TO A MINIMUM DEPTH OF TWO FEET BELOW PROPOSED FINAL GRADE OR TO A DEPTH AT WHICH SOILS ARE STABLE. AFTER THIS HAS BEEN COMPLETED, THE EXPOSED MATERIALS SHALL BE SCARIFIED TO A DEPTH OF 12 INCHES AND MOISTURE CONDITIONED. THE SUBGRADE SHALL THEN BE UNIFORMLY COMPACTED TO A MINIMUM OF 95% OF STANDARD PROCTOR DENSITY (ASTM D-698) AT 0 TO +4.0% OF OPTIMUM MOISTURE CONTENT FOR A-6 AND A-7-6 SOILS ENCOUNTERED. OTHER SUBGRADE TYPES SHALL BE UNIFORMLY COMPACTED TO A MINIMUM OF 95% OF MODIFIED PROCTOR DENSITY (ASTM D-1557) AT PLUS OR MINUS 2.0% OF OPTIMUM MOISTURE CONTENT. AREAS WHERE STABLE NATURAL SOILS ARE ENCOUNTERED AT PROPOSED SUBGRADE ELEVATION SHALL ALSO BE SCARIFIED (18 INCHES FOR A-7-6 SOILS BELOW FULL-DEPTH ASPHALT CONCRETE) AND COMPACTED AS OUTLINED ABOVE PRIOR TO PAVING OPERATIONS. SUBGRADE FILL SHALL BE PLACED IN SIX-INCH LIFTS AND UNIFORMLY COMPACTED, MEETING THE REQUIREMENTS AS PREVIOUSLY DESCRIBED.
- SUBGRADE MATERIALS DEEMED UNSUITABLE BY THE ENGINEER SHALL BE EXCAVATED, DISPOSED OF AND REPLACED WITH APPROVED MATERIALS.
- FILL SHALL BE PLACED IN 8-INCH MAXIMUM LOOSE LIFTS AND SHALL BE COMPACTED PRIOR TO SUCCESSIVE LIFTS.
- THE CONTRACTOR IS RESPONSIBLE FOR PREVENTING AND CONTROLLING EROSION DURING CONSTRUCTION ACTIVITIES AT ALL TIMES DURING GRADING AND CONSTRUCTION. THE CONTRACTOR SHALL PROVIDE THE FOLLOWING EROSION AND SEDIMENT CONTROL MEASURES:
  - HAY BALE BARRIERS WHERE NEEDED AND/OR AS DIRECTED BY THE ENGINEER.
  - SILT FENCE WHERE NEEDED AND/OR AS DIRECTED BY THE ENGINEER.
  - TEMPORARY SEDIMENTATION BASINS WHERE NEEDED AND/OR AS DIRECTED BY THE ENGINEER.
  - MULCHING AND SEEDING OF EXCESSIVE SLOPED AREAS AS NEEDED OR AS DIRECTED BY THE ENGINEER.
  - TEMPORARY VEHICLE TRACKING CONTROL AS NEEDED AND/OR DIRECTED BY THE ENGINEER.
  - CONCRETE WASH AREAS.
  - INLET PROTECTION.
 THESE AND ALL EROSION CONTROL BEST MANAGEMENT PRACTICES AS SHOWN IN THE GRADING AND EROSION CONTROL PLANS SHALL BE STRICTLY ADHERED TO.
- FINISHED CONTOURS/SPOT ELEVATIONS SHOWN HEREON REPRESENT FINISHED GRADES. ALL PAVEMENT SUBGRADES ARE BASED ON THE COMPOSITE ASPHALT PAVEMENT RECOMMENDATIONS MADE IN THE "GEOTECHNICAL STUDY" FOR THIS PROJECT.
- THERE MAY BE SOME TOPSOIL WITHIN LORSON RANCH EAST THAT IS NOT SUITABLE FOR RE-USE. CONTRACTOR SHALL AMEND THE TOPSOIL AS NECESSARY AND RE-SPREAD IN ACCORDANCE WITH THE GEOTECHNICAL RECOMMENDATIONS. IF TOPSOIL CANNOT BE AMENDED IT SHALL BE USED AS FILL WHERE NO FUTURE STRUCTURES OR ROADS WILL BE BUILT.

ADDITIONAL SWMP PLAN CONTRACTOR NOTES:

- CONTRACTOR MUST ADD THEIR CONTACT INFORMATION TO THE SWMP PLANS PRIOR TO CONSTRUCTION
- IF THE GRADING IS TO BE PHASED THE CONTRACTOR MUST PROVIDE PHASING MAPS FOR INSERTION INTO THE SWMP PLANS.
- THE CONTRACTOR MUST PROVIDE THE CLIENT THE LOCATION OF ANY POTENTIAL SOURCES OF POLLUTIONS SUCH AS FUELING AREAS, ETC TO BE INSERTED INTO THE SWMP PLANS.
- THE ON-SITE SWMP PLAN SHALL BE LOCATED AT THE SE CORNER OF FONTAINE BLVD AND MARKSHEFFEL ROAD UNLESS OTHERWISE DOCUMENTED.
- EXISTING VEGETATION WITHIN THE LIMITS OF CONSTRUCTION CONSISTS OF NATIVE GRASSES AND WEEDS. GROUND COVER IS ESTIMATED AT 70% DENSITY. EXISTING VEGETATION WILL BE VERIFIED VISUALLY IN THE FIELD PRIOR TO STARTING WORK.

EL PASO COUNTY STANDARD CONSTRUCTION NOTES:

- ALL DRAINAGE AND ROADWAY CONSTRUCTION SHALL MEET THE STANDARDS AND SPECIFICATIONS OF THE CITY OF COLORADO SPRINGS/EL PASO COUNTY DRAINAGE CRITERIA MANUAL, VOLUMES 1 AND 2, AND THE EL PASO COUNTY ENGINEERING CRITERIA MANUAL.
- CONTRACTOR SHALL BE RESPONSIBLE FOR THE NOTIFICATION AND FIELD NOTIFICATION OF ALL EXISTING UTILITIES, WHETHER SHOWN ON THE PLANS OR NOT, BEFORE BEGINNING CONSTRUCTION. LOCATION OF EXISTING UTILITIES SHALL BE VERIFIED BY THE CONTRACTOR PRIOR TO CONSTRUCTION. CALL 811 TO CONTACT THE UTILITY NOTIFICATION CENTER OF COLORADO (UNCC).
- CONTRACTOR SHALL KEEP A COPY OF THESE APPROVED PLANS, THE GRADING AND EROSION CONTROL PLAN, THE STORMWATER MANAGEMENT PLAN (SWMP), THE SOILS AND GEOTECHNICAL REPORT, AND THE APPROPRIATE DESIGN AND CONSTRUCTION STANDARDS AND SPECIFICATIONS AT THE JOB SITE AT ALL TIMES, INCLUDING THE FOLLOWING:
  - EL PASO COUNTY ENGINEERING CRITERIA MANUAL (ECM)
  - CITY OF COLORADO SPRINGS/EL PASO COUNTY DRAINAGE CRITERIA MANUAL, VOLUMES 1 AND 2
  - COLORADO DEPARTMENT OF TRANSPORTATION (CDOT) STANDARD SPECIFICATIONS FOR ROAD AND BRIDGE CONSTRUCTION
  - CDOT M & S STANDARDS
- NOTWITHSTANDING ANYTHING DEPICTED IN THESE PLANS IN WORDS OR GRAPHIC REPRESENTATION, ALL DESIGN AND CONSTRUCTION RELATED TO ROADS, STORM DRAINAGE AND EROSION CONTROL SHALL CONFORM TO THE STANDARDS AND REQUIREMENTS OF THE MOST RECENT VERSION OF THE RELEVANT ADOPTED EL PASO COUNTY STANDARDS, INCLUDING THE LAND DEVELOPMENT CODE, THE ENGINEERING CRITERIA MANUAL, THE DRAINAGE CRITERIA MANUAL, AND THE DRAINAGE CRITERIA MANUAL VOLUME 2. ANY DEVIATIONS FROM REGULATIONS AND STANDARDS MUST BE REQUESTED, AND APPROVED, IN WRITING. ANY MODIFICATIONS NECESSARY TO MEET CRITERIA AFTER-THE-FACT WILL BE ENTIRELY THE DEVELOPER'S RESPONSIBILITY TO RECTIFY.
- IT IS THE DESIGN ENGINEER'S RESPONSIBILITY TO ACCURATELY SHOW EXISTING CONDITIONS, BOTH ONSITE AND OFFSITE, ON THE CONSTRUCTION PLANS. ANY MODIFICATIONS NECESSARY DUE TO CONFLICTS, OMISSIONS, OR CHANGED CONDITIONS WILL BE ENTIRELY THE DEVELOPER'S RESPONSIBILITY TO RECTIFY.
- CONTRACTOR SHALL SCHEDULE A PRE-CONSTRUCTION MEETING WITH EL PASO COUNTY PLANNING AND COMMUNITY DEVELOPMENT (PCD) - INSPECTIONS, PRIOR TO STARTING CONSTRUCTION.
- IT IS THE CONTRACTOR'S RESPONSIBILITY TO UNDERSTAND THE REQUIREMENTS OF ALL JURISDICTIONAL AGENCIES AND TO OBTAIN ALL REQUIRED PERMITS, INCLUDING BUT NOT LIMITED TO EL PASO COUNTY EROSION AND STORMWATER QUALITY CONTROL PERMIT (ESQCP), REGIONAL BUILDING FLOODPLAIN DEVELOPMENT PERMIT, U.S. ARMY CORPS OF ENGINEERS-ISSUED 401 AND/OR 404 PERMITS, AND COUNTY AND STATE FUGITIVE DUST PERMITS.
- CONTRACTOR SHALL NOT DEVIATE FROM THE PLANS WITHOUT FIRST OBTAINING WRITTEN APPROVAL FROM THE DESIGN ENGINEER AND DSD. CONTRACTOR SHALL NOTIFY THE DESIGN ENGINEER IMMEDIATELY UPON DISCOVERY OF ANY ERRORS OR INCONSISTENCIES.
- ALL STORM DRAIN PIPE SHALL BE CLASS III RCP UNLESS OTHERWISE NOTED AND APPROVED BY PCD.
- CONTRACTOR SHALL COORDINATE GEOTECHNICAL TESTING PER ECM STANDARDS. PAVEMENT DESIGN SHALL BE APPROVED BY EL PASO COUNTY PCD PRIOR TO PLACEMENT OF CURB AND GUTTER AND PAVEMENT.
- ALL CONSTRUCTION TRAFFIC MUST ENTER/EXIT THE SITE AT APPROVED CONSTRUCTION ACCESS POINTS.
- SIGHT VISIBILITY TRIANGLES AS IDENTIFIED IN THE PLANS SHALL BE PROVIDED AT ALL INTERSECTIONS. OBSTRUCTIONS GREATER THAN 18 INCHES ABOVE FLOWLINE ARE NOT ALLOWED WITHIN SIGHT TRIANGLES.
- SIGNING AND STRIPING SHALL COMPLY WITH EL PASO COUNTY PUBLIC WORK DEPARTMENT AND MUTCD CRITERIA.
- CONTRACTOR SHALL OBTAIN ANY PERMITS REQUIRED BY EL PASO COUNTY PWD, INCLUDING WORK WITHIN THE RIGHT-OF-WAY AND SPECIAL TRANSPORT PERMITS.
- THE LIMITS OF CONSTRUCTION SHALL REMAIN WITHIN THE PROPERTY LINE UNLESS OTHERWISE NOTED. THE OWNER/DEVELOPER SHALL OBTAIN WRITTEN PERMISSION AND EASEMENTS, WHERE REQUIRED, FROM ADJOINING PROPERTY OWNER(S) PRIOR TO ANY OFF-SITE DISTURBANCE, GRADING, OR CONSTRUCTION.

**GEOTECHNICAL REPORT NOTE**

- ALL GRADING SHALL CONFORM TO THE GEOTECHNICAL RECOMMENDATIONS PREPARED BY RMG, " SOILS AND GEOLOGY FOR CREEKSIDE SOUTH AT LORSON RANCH FILING NO. 2", DATED FEBRUARY 21, 2022, JOB NO. 185657.

STANDARD NOTES FOR EL PASO COUNTY GRADING AND EROSION CONTROL PLANS

- Stormwater discharges from construction sites shall not cause or threaten to cause pollution, contamination, or degradation of State Waters. All work and earth disturbance shall be done in a manner that minimizes pollution of any on-site or off-site waters, including wetlands.
- Notwithstanding anything depicted in these plans in words or graphic representation, all design and construction related to roads, storm drainage and erosion control shall conform to the standards and requirements of the most recent version of the relevant adopted El Paso County standards, including the Land Development Code, the Engineering Criteria Manual, the Drainage Criteria Manual, and the Drainage Criteria Manual Volume 2. Any deviations from regulations and standards must be requested, and approved, in writing.
- A separate Stormwater Management Plan (SWMP) for this project shall be completed and an Erosion and Stormwater Quality Control Permit (ESQCP) issued prior to commencing construction. Management of the SWMP during construction is the responsibility of the designated Qualified Stormwater Manager or Certified Erosion Control Inspector. The SWMP shall be located on site at all times during construction and shall be kept up to date with work progress and changes in the field.
- Once the ESQCP is approved and a "Notice to Proceed" has been issued, the contractor may install the initial stage erosion and sediment control measures as indicated on the approved GEC. A Preconstruction Meeting between the contractor, engineer, and El Paso County will be held prior to any construction. It is the responsibility of the applicant to coordinate the meeting time and place with County staff.
- Control measures must be installed prior to commencement of activities that could contribute pollutants to stormwater. Control measures for all slopes, channels, ditches, and disturbed land areas shall be installed immediately upon completion of the disturbance.
- All temporary sediment and erosion control measures shall be maintained and remain in effective operating condition until permanent soil erosion control measures are implemented and final stabilization is established. All persons engaged in land disturbance activities shall assess the adequacy of control measures at the site and identify if changes to those control measures are needed to ensure the continued effective performance of the control measures. All changes to temporary sediment and erosion control measures must be incorporated into the Stormwater Management Plan.
- Temporary stabilization shall be implemented on disturbed areas and stockpiles where ground disturbing construction activity has permanently ceased or temporarily ceased for longer than 14 days.
- Final stabilization must be implemented at all applicable construction sites. Final stabilization is achieved when all ground disturbing activities are complete and all disturbed areas either have a uniform vegetative cover with individual plant density of 70 percent of pre-disturbance levels established or equivalent permanent alternative stabilization method is implemented. All temporary sediment and erosion control measures shall be removed upon final stabilization and before permit closure.
- All permanent stormwater management facilities shall be installed as designed in the approved plans. Any proposed changes that effect the design or function of permanent stormwater management structures must be approved by the ECM Administrator prior to implementation.
- Earth disturbances shall be conducted in such a manner so as to effectively minimize accelerated soil erosion and resulting sedimentation. All disturbances shall be designed, constructed, and completed so that the exposed area of any disturbed land shall be limited to the shortest practical period of time. Pre-existing vegetation shall be protected and maintained within 50 horizontal feet of a waters of the state unless shown to be infeasible and specifically requested and approved.
- Compaction of soil must be prevented in areas designated for infiltration control measures or where final stabilization will be achieved by vegetative cover. Areas designated for infiltration control measures shall also be protected from sedimentation during construction until final stabilization is achieved. If compaction prevention is not feasible due to site constraints, all areas designated for infiltration and vegetation control measures must be loosened prior to installation of the control measure(s).
- Any temporary or permanent facility designed and constructed for the conveyance of stormwater around, through, or from the earth disturbance area shall be a stabilized conveyance designed to minimize erosion and the discharge of sediment off site.
- Concrete wash water shall be contained and disposed of in accordance with the SWMP. No wash water shall be discharged to or allowed to enter State Waters, including any surface or subsurface storm drainage system or facilities. Concrete washouts shall not be located in an area where shallow groundwater may be present, or within 50 feet of a surface water body, creek or stream.
- During dewatering operations of uncontaminated ground water may be discharged on site, but shall not leave the site in the form of surface runoff unless an approved State dewatering permit is in place.
- Erosion control blanketing or other protective covering shall be used on slopes steeper than 3:1.
- Contractor shall be responsible for the removal of all wastes from the construction site for disposal in accordance with local and State regulatory requirements. No construction debris, tree slash, building material wastes or unused building materials shall be buried, dumped, or discharged at the site.
- Waste materials shall not be temporarily placed or stored in the street, alley, or other public way, unless in accordance with an approved Traffic Control Plan. Control measures may be required by El Paso County Engineering if deemed necessary, based on specific conditions and circumstances.
- Tracking of soils and construction debris off-site shall be minimized. Materials tracked off-site shall be cleaned up and properly disposed of immediately.
- The owner/developer shall be responsible for the removal of all construction debris, dirt, trash, rock, sediment, soil, and sand that may accumulate in roads, storm drains and other drainage conveyance systems and stormwater appurtenances as a result of site development.
- The quantity of materials stored on the project site shall be limited, as much as practical, to that quantity required to perform the work in an orderly sequence. All materials stored on-site shall be stored in a neat, orderly manner, in their original containers, with original manufacturer's labels.
- No chemical(s) having the potential to be released in stormwater are to be stored or used onsite unless permission for the use of such chemical(s) is granted in writing by the ECM Administrator. In granting approval for the use of such chemical(s), special conditions and monitoring may be required.
- Bulk storage of allowed petroleum products or other allowed liquid chemicals in excess of 55 gallons shall require adequate secondary containment protection to contain all spills onsite and to prevent any spilled materials from entering State Waters, any surface or subsurface storm drainage system or other facilities.
- No person shall cause the impediment of stormwater flow in the curb and gutter or ditch except with approved sediment control measures.
- Owner/developer and their agents shall comply with the "Colorado Water Quality Control Act" (Title 25, Article 8, CRS), and the "Clean Water Act" (33 USC 1344), in addition to the requirements of the Land Development Code, DCM Volume II and the ECM Appendix I. All appropriate permits must be obtained by the contractor prior to construction (1041, NPDES, Floodplain, 404, fugitive dust, etc.). In the event of conflicts between these requirements and other laws, rules, or regulations of other Federal, State, local, or County agencies, the most restrictive laws, rules, or regulations shall apply.
- All construction traffic must enter/exit the site only at approved construction access points.
- Prior to construction the permittee shall verify the location of existing utilities.
- A water source shall be available on site during earthwork operations and shall be utilized as required to minimize dust from earthwork equipment and wind.
- The soils report for this site has been prepared by RMG and shall be considered a part of these plans. See Geotechnical Report Note.
- At least ten (10) days prior to the anticipated start of construction, for projects that will disturb one (1) acre or more, the owner or operator of construction activity shall submit a permit application for stormwater discharge to the Colorado Department of Public Health and Environment, Water Quality Division. The application contains certification of completion of a stormwater management plan (SWMP), of which this Grading and Erosion Control Plan may be a part. For information or application materials contact:

Colorado Department of Public Health and Environment  
Water Quality Control Division  
WQCD - Permits  
4300 Cherry Creek Drive South  
Denver, CO 80246-1530  
Attn: Permits Unit

**CORE ENGINEERING GROUP**  
1500 WEST AVENUE, SUITE 500  
BOULDER, CO 80506  
PHONE: 719.570.1100  
CONTACT: RICHARD L. SCHINDLER, P.E.  
EMAIL: Rich@ceg1.com

DATE: \_\_\_\_\_  
DESCRIPTION: \_\_\_\_\_  
NO: \_\_\_\_\_  
PREPARED FOR: LORSON, LLC  
212 N. WAHSATCH AVE, SUITE 301  
COLORADO SPRINGS, COLORADO 80903  
CONTACT: JEFF MARK  
PROJECT: CREEKSIDE SOUTH AT LORSON RANCH 2  
LORSON BLVD TRAPPE DR  
COLORADO SPRINGS, COLORADO

DRAWN: RLS  
DESIGNED: RLS  
CHECKED: RLS

**OVERLOT EARLY SITE GRADING PLAN NOTES**



DATE: AUG 24, 2022

PROJECT NO. 100.069

SHEET NUMBER C0.2

TOTAL SHEETS: 8



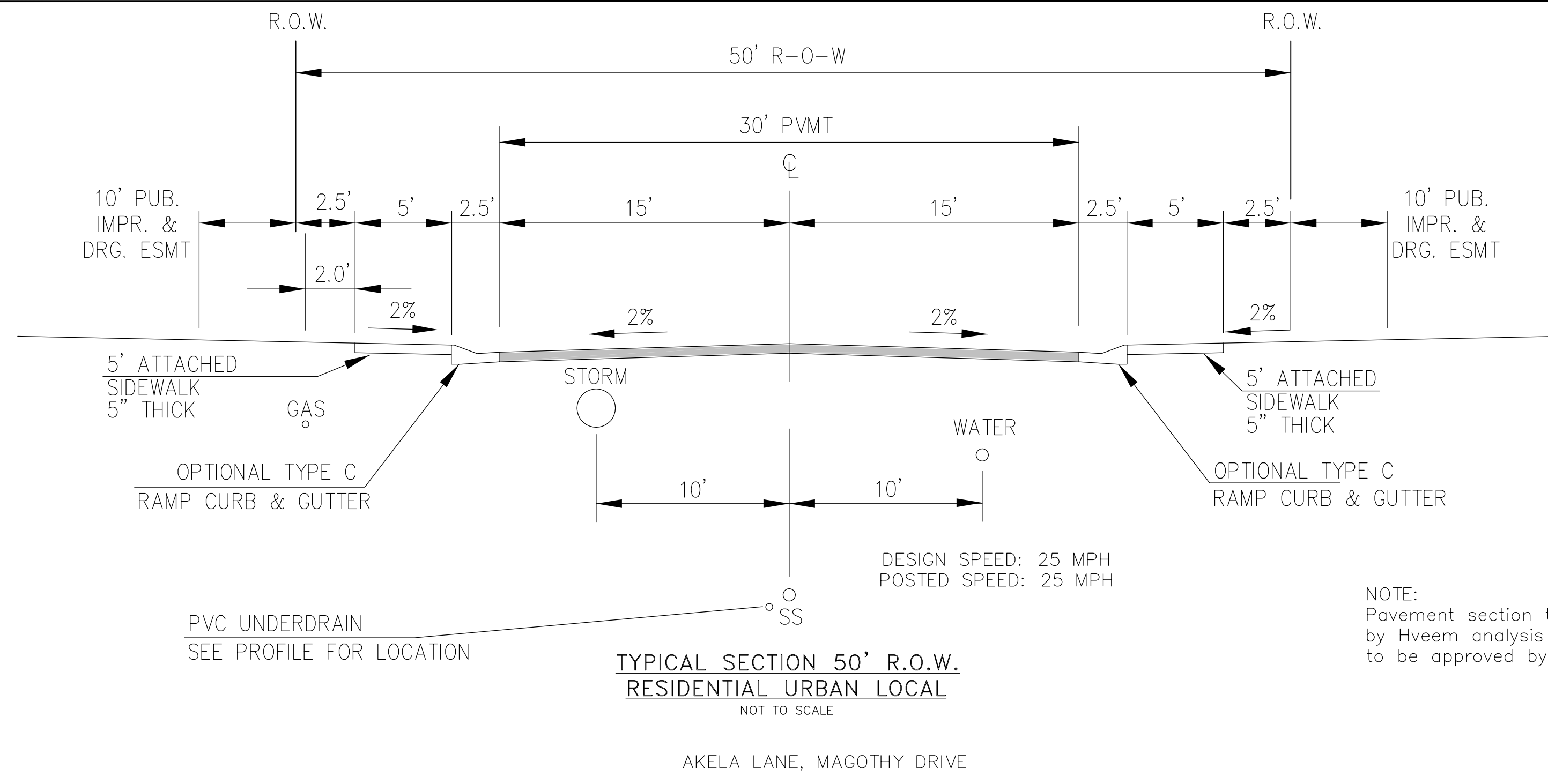

**CORE**  
**ENGINEERING GROUP**  
15004 1ST AVENUE S.  
BURNSVILLE, MN 55306  
PH: 719.570.1100  
CONTACT: RICHARD L. SCHINDLER, P.E.  
EMAIL: Rich@cegi.com

DATE: \_\_\_\_\_  
DESCRIPTION: \_\_\_\_\_  
NO. \_\_\_\_\_

PREPARED FOR:  
**LORSON, LLC**  
212 N. WAHSATCH AVE, SUITE 301  
COLORADO SPRINGS, COLORADO 80903  
(719) 635-3200  
CONTACT: JEFF MARK

PROJECT:  
**CREEKSIDE SOUTH AT  
LORSON RANCH 2**  
LORSON BLVD. - TRAPPE DR.  
COLORADO SPRINGS, COLORADO

DRAWN: RLS  
DESIGNED: RLS  
CHECKED: RLS

**OVERLOT EARLY  
SITE GRADING  
TYPICAL ROADWAY SECTIONS**



DATE:  
AUG 24, 2022

PROJECT NO.  
100.069

SHEET NUMBER  
**C0.3**

TOTAL SHEETS: 8



**LEGEND**

- 5721----- EXISTING MINOR CONTOUR
- 5720----- EXISTING MAJOR CONTOUR
- 5720----- PROPOSED CONTOUR
- EXISTING STORM SEWER
- PROPOSED STORM SEWER, INLETS, MANHOLES
- (SF)----- PERIMETER EROSION CONTROL  
SILT FENCE, EROSION LOG, OR EARTH BERM
- SUBDIVISION BOUNDARY
- CONSTRUCTION BOUNDARY/LIMITS OF DISTURBANCE
- P/L----- PROPERTY LINE OR TRACT LINE
- ROW LINE
- ←----- STORMWATER RUNOFF DIRECTION
- X%----- SLOPE DIRECTION AND GRADE
- (VTC)----- VEHICLE TRACKING CONTROL
- COMPACTED EARTHEN BERM OR ROUGH CUT STREET CONTROL PLAN or STRAW BALE CHECK DAM
- CUT/FILL LINE
- (PS)----- PERMANENT SEEDING
- (IP)----- INLET PROTECTION
- (MU)----- MULCH

**NOTE:**

1. SLOPES SHALL BE 4:1 UNLESS OTHERWISE NOTED
2. POND SLOPES SHALL BE 4:1
3. STRAW ECB SHALL BE PLACED ON ALL SIDE SLOPES AND PERMANENT SLOPES 3:1 OR STEEPER
4. TEMPORARY SEEDING REQUIRED ON DISTURBED AREAS AND STOCKPILES WHICH ARE NOT AT FINAL GRADE BUT WILL REMAIN DORMANT FOR LONGER THAN 30 DAYS SHALL ALSO BE MULCHED AND SEEDED WITHIN 21 DAYS AFTER INTERIM GRADING.
5. THERE ARE NO ASPHALT BATCH PLANTS OR CONSTRUCTION OFFICE TRAILERS PLANNED FOR THIS SITE OR CONTRACTOR SHALL OBTAIN PERMIT IF DESIRED.
6. CONTRACTOR TO DETERMINE STOCKPILE AREAS, CONCRETE WASHOUT AREAS, AND STAGING AREAS AND SHOW THEM ON THE WORKING MAPS.
7. EXISTING VEGETATION CONSISTS OF GRASSES AND WEEDS. GROUND COVER ESTIMATED AT 65% DENSITY AND WILL BE FIELD VERIFIED AT THE TIME OF CONSTRUCTION
8. THE STAGING AREA WILL BE DETERMINED IN THE FIELD PRIOR TO CONSTRUCTION AND WILL BE DEPICTED ON THE SWMP PLAN AT THAT TIME
9. THE SWMP MANUAL IS LOCATED AT THE SE CORNER OF MARKSHEFFEL ROAD AND FONTAINE BOULEVARD.
10. THERE ARE NO STREAMS OR WETLANDS WITHIN THE LIMITS OF CONSTRUCTION

**INITIAL BMP'S:**

1. PERIMETER SILT FENCE
2. VEHICLE TRACKING CONTROL PADS
3. INLET PROTECTION FOR EXISTING INLETS
4. PLACEMENT OF ON-SITE SWMP MANUAL

**INTERIM BMP'S:**

1. TEMPORARY SEDIMENT TRAPS AS GRADING PROGRESSES
2. TEMPORARY SEEDING/MULCHING AS NEEDED
3. STRAW BALE CHECKS AS NEEDED DURING GRADING

**FINAL BMP'S:**

1. FINAL SEEDING AND MULCHING
2. STRAW ECB ON PERMANENT SLOPES 3:1 OR STEEPER.

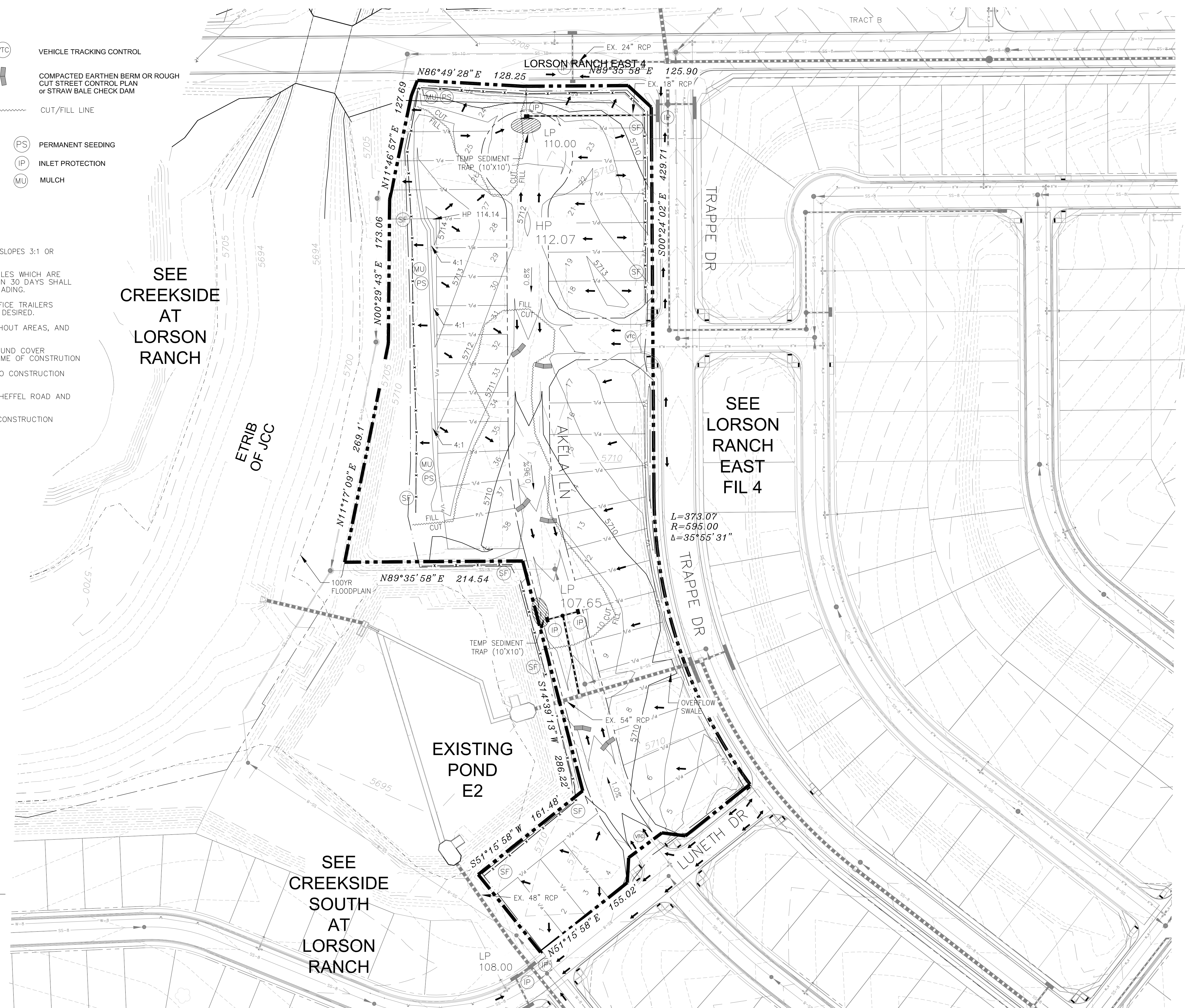
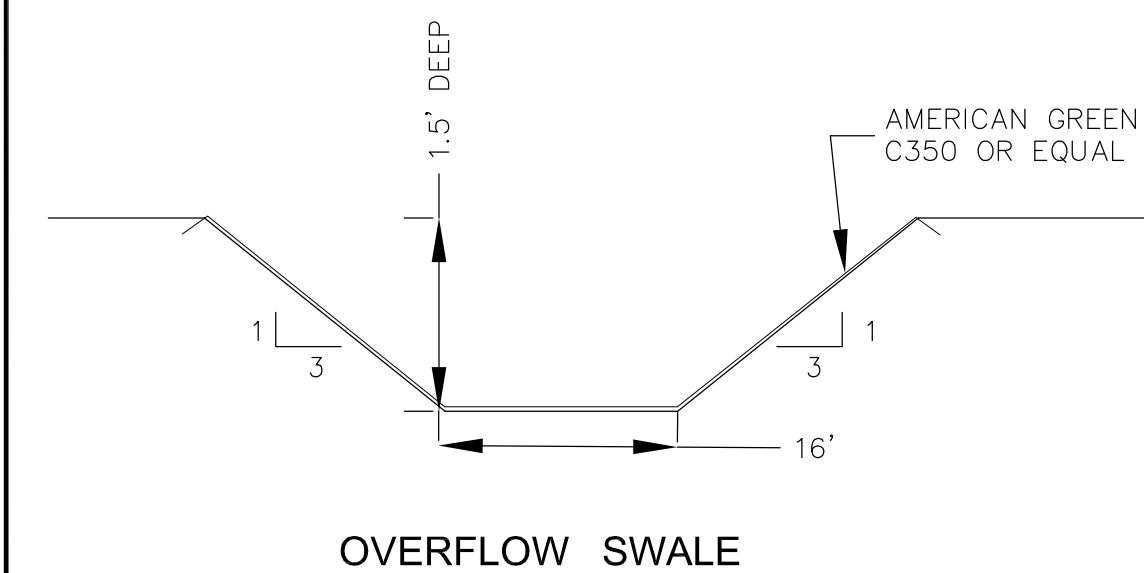
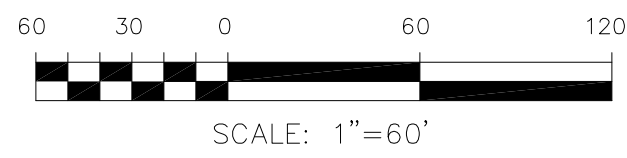
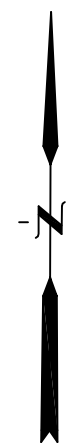

<b>CORE ENGINEERING GROUP</b>	
1500 S. 151st AVENUE, SUITE 300 COLORADO SPRINGS, CO 80903 PH: 719.570.1100 CONTACT: RICHARD L. SCHINDLER, P.E. EMAIL: Rich@ceg1.com	
PREPARED FOR: <b>LORSON, LLC</b> 212 N. WAHSATCH AVE, SUITE 301 COLORADO SPRINGS, COLORADO 80903 CONTACT: JEFF MARK	PROJECT: <b>CREEKSIDE SOUTH AT LORSON RANCH 2</b> LORSON BLVD TRAPPE DR COLORADO SPRINGS, COLORADO
DRAWN: RLS DESIGNED: RLS CHECKED: RLS	<b>CREEKSIDE SOUTH AT LORSON RANCH 2</b> <b>OVERLOT EARLY GRADING AND</b> <b>EROSION CONTROL PLAN</b>
DATE: AUG 24, 2022	
PROJECT NO. 100.069	
SHEET NUMBER <b>C4.1</b>	
TOTAL SHEETS: 8	



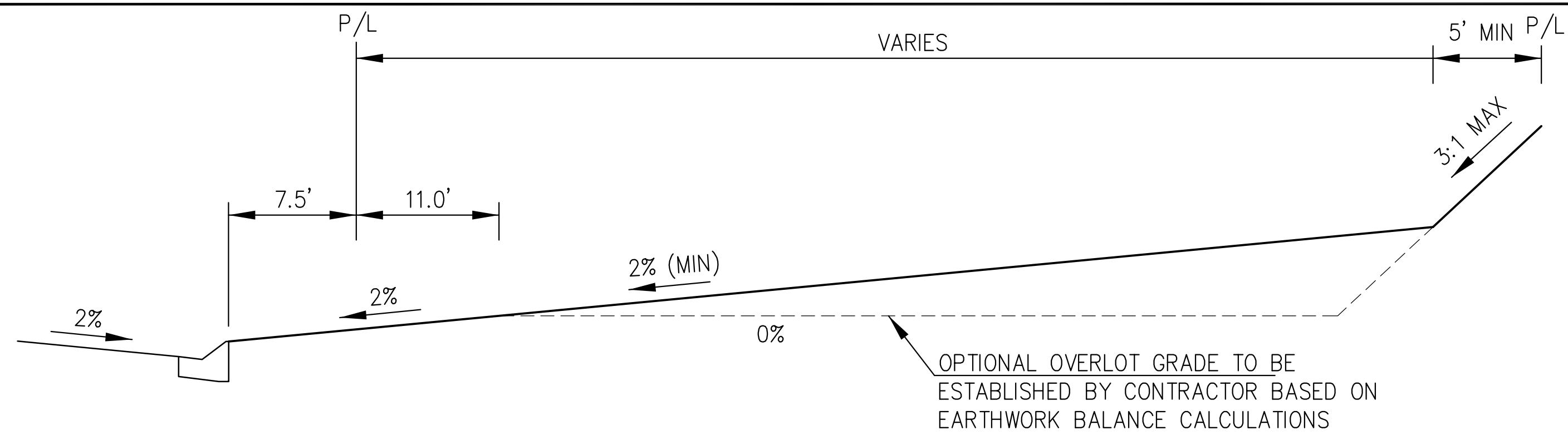

TYPICAL "A" LOT

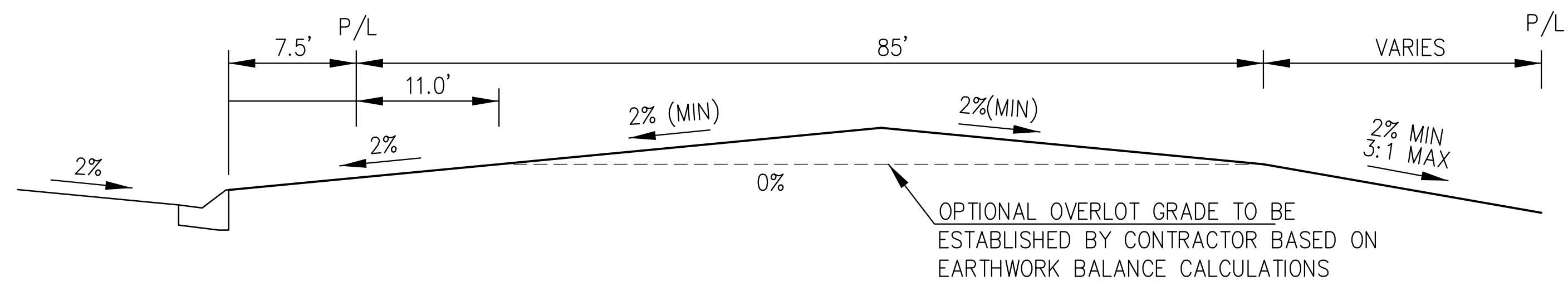

TYPICAL "B" LOT

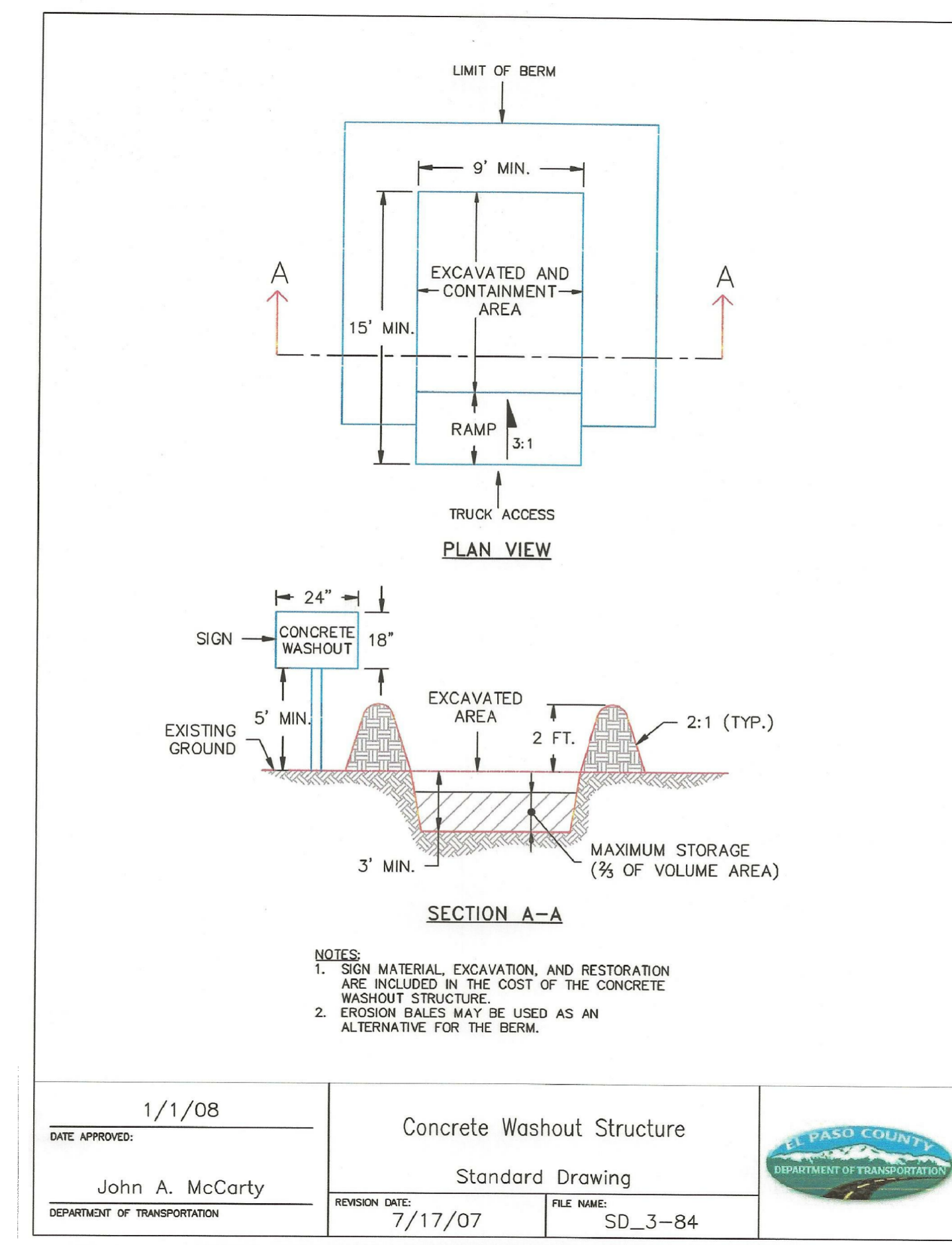
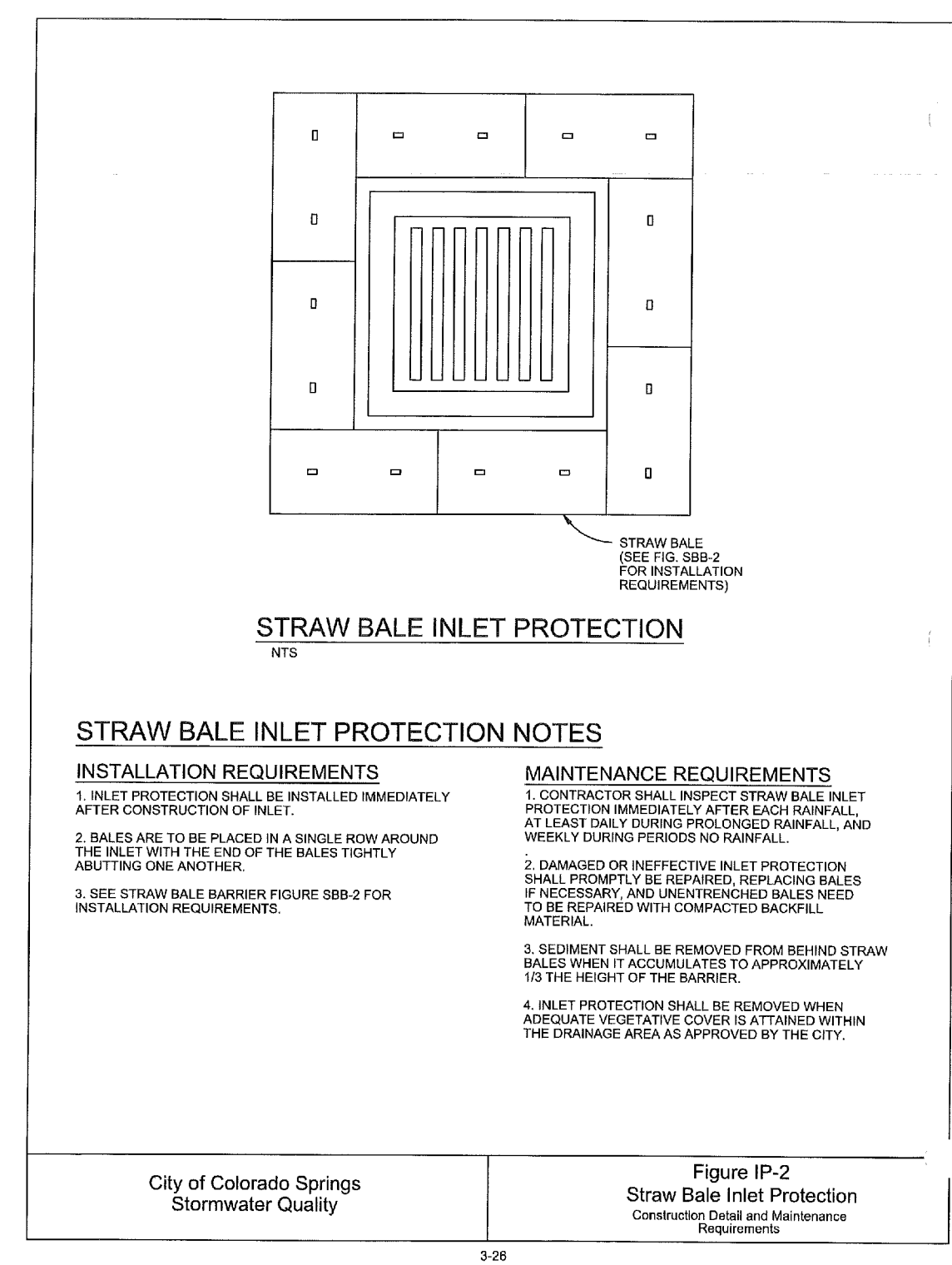
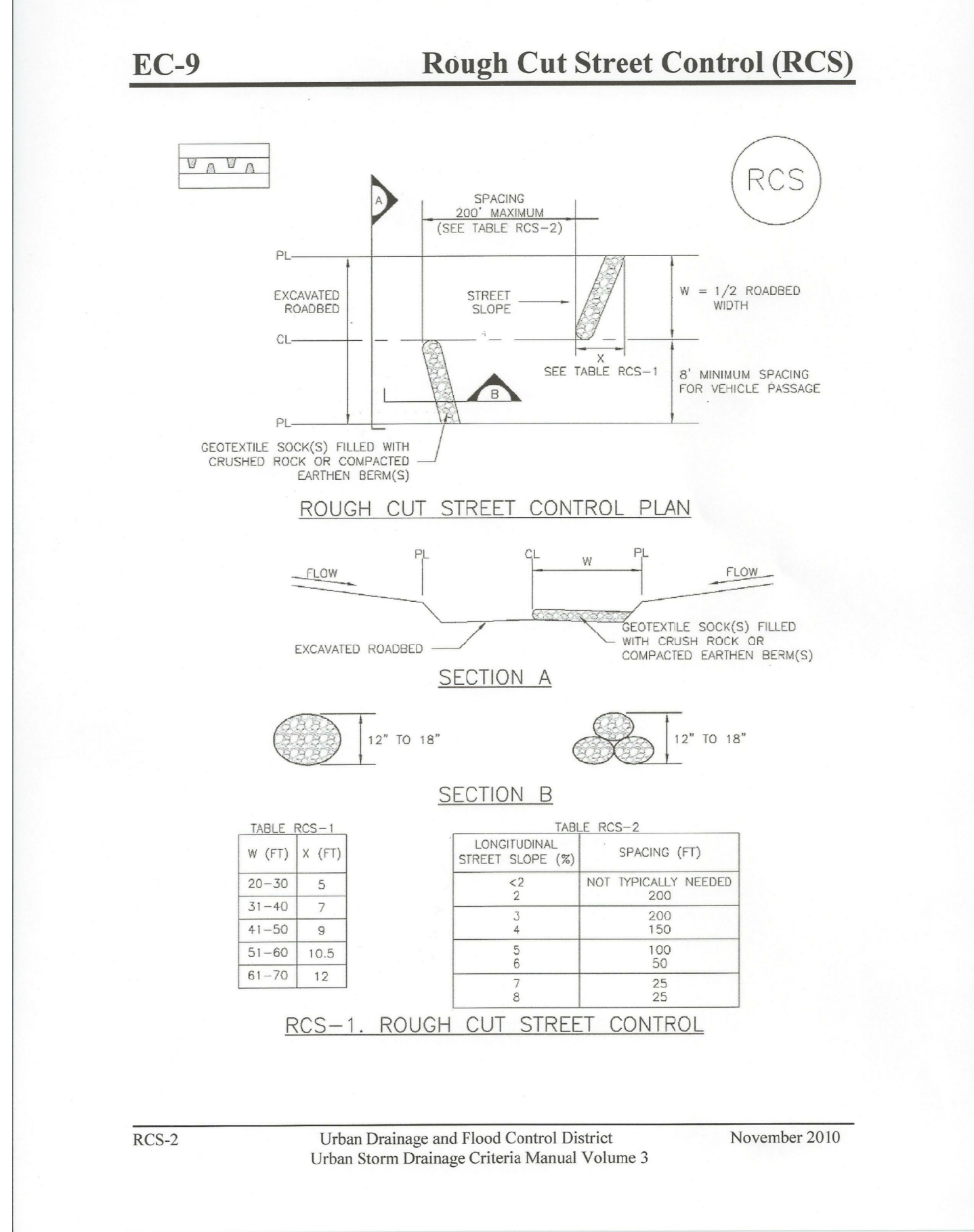
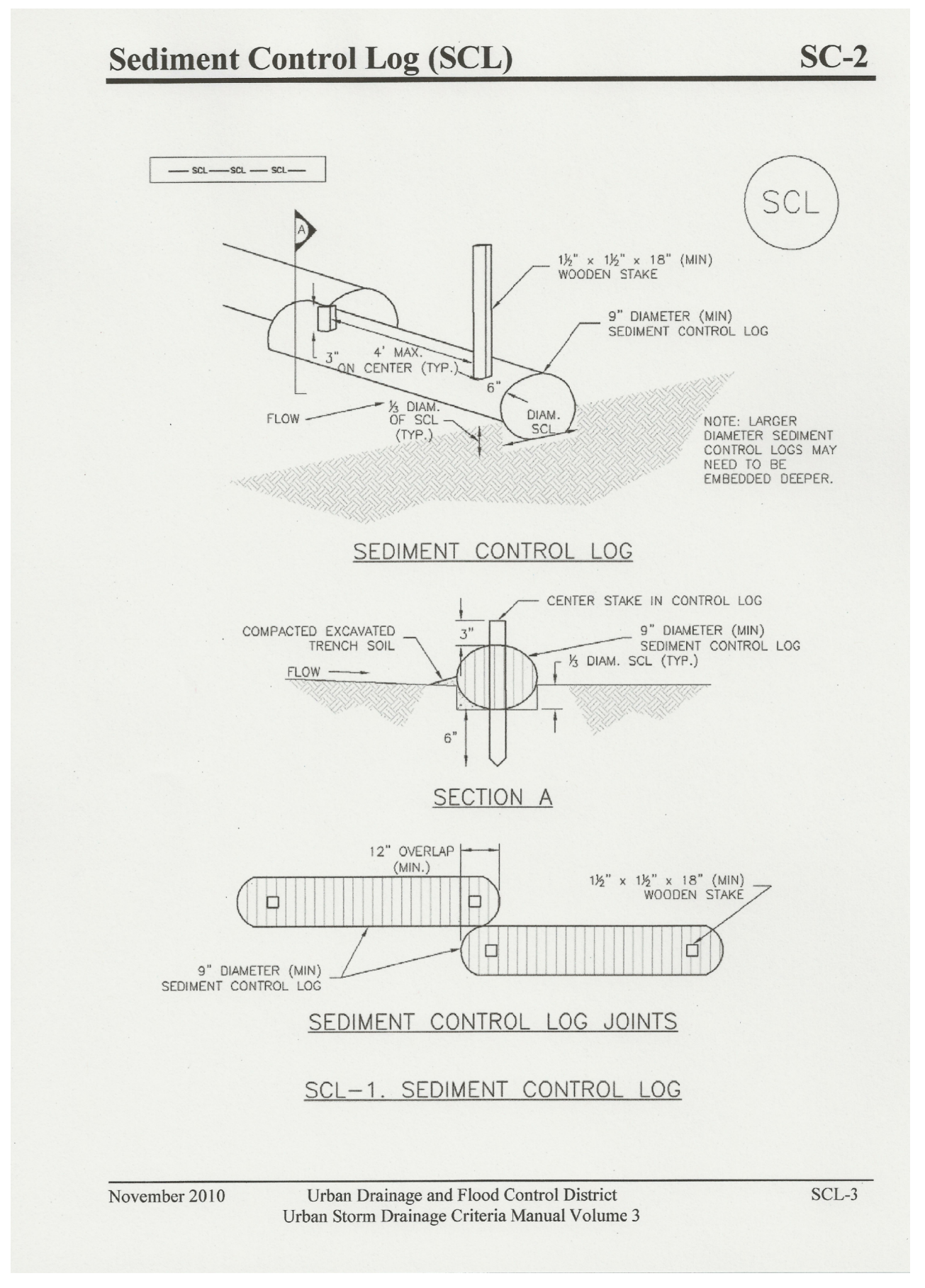

**CORE ENGINEERING GROUP**  
 1500 S. 1ST AVENUE, SUITE 35506  
 DENVER, CO 80202  
 PH: 719.570.1100 CONTACT: RICHARD L. SCHINDLER, P.E.  
 EMAIL: Rich@ceg.com

DATE: \_\_\_\_\_

DESCRIPTION: \_\_\_\_\_

NO. \_\_\_\_\_

PREPARED FOR: **LORSON, LLC**  
 212 N. WAHSATCH AVE, SUITE 301  
 COLORADO SPRINGS, COLORADO 80903  
 (719) 635-3200 CONTACT: JEFF MARK

PROJECT: **CREEKSIDE SOUTH AT LORSON RANCH 2**  
 LORSON BLVD. TRAPPE DR. COLORADO SPRINGS, COLORADO

DRAWN: RLS  
 DESIGNED: RLS  
 CHECKED: RLS

**GRADING AND EROSION CONTROL DETAILS**

DATE: AUG 24, 2022

PROJECT NO. 100.069

SHEET NUMBER C12.1

TOTAL SHEETS: 8



Vehicle Tracking Control (VTC) SM-4

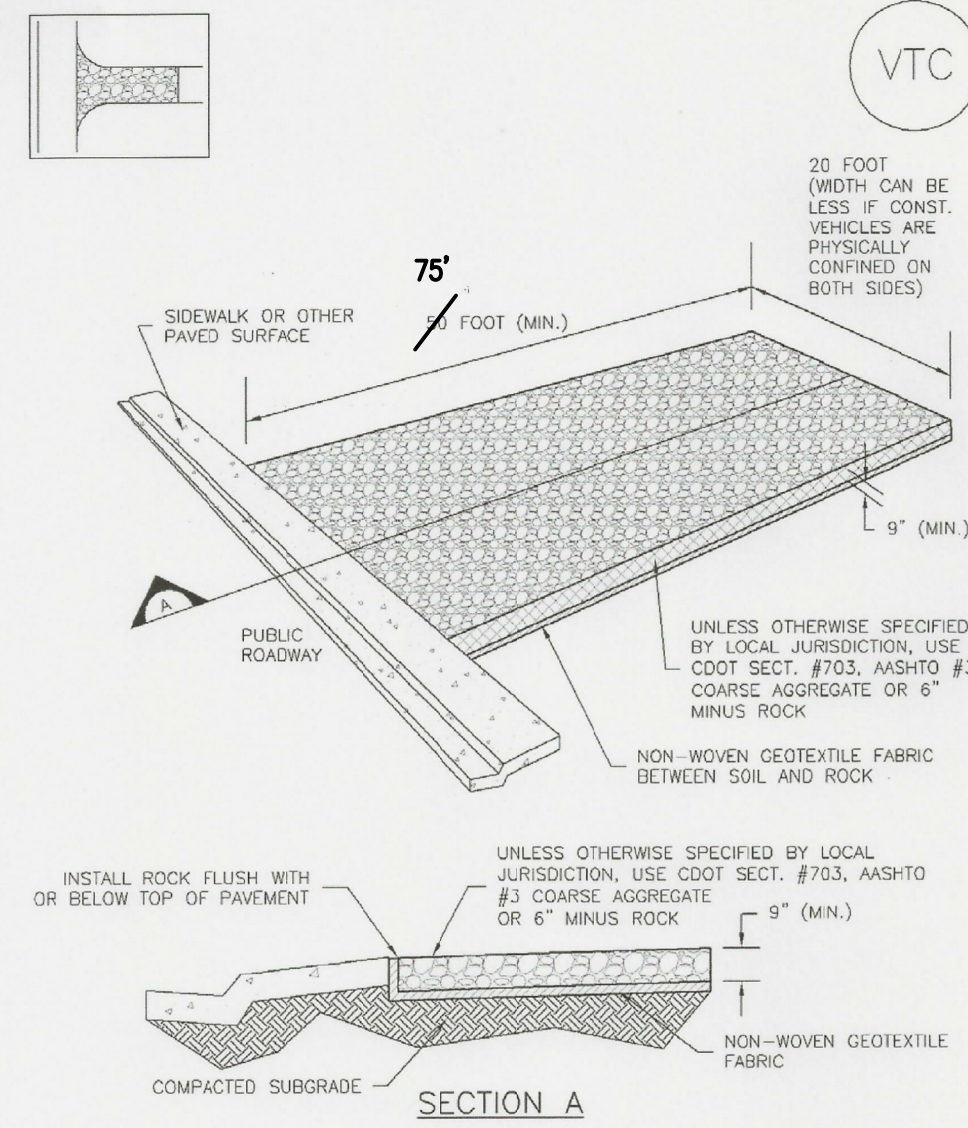

VTC-1. AGGREGATE VEHICLE TRACKING CONTROL

November 2010 Urban Drainage and Flood Control District Urban Storm Drainage Criteria Manual Volume 3 VTC-3

EC-6 Rolled Erosion Control Products (RECP)

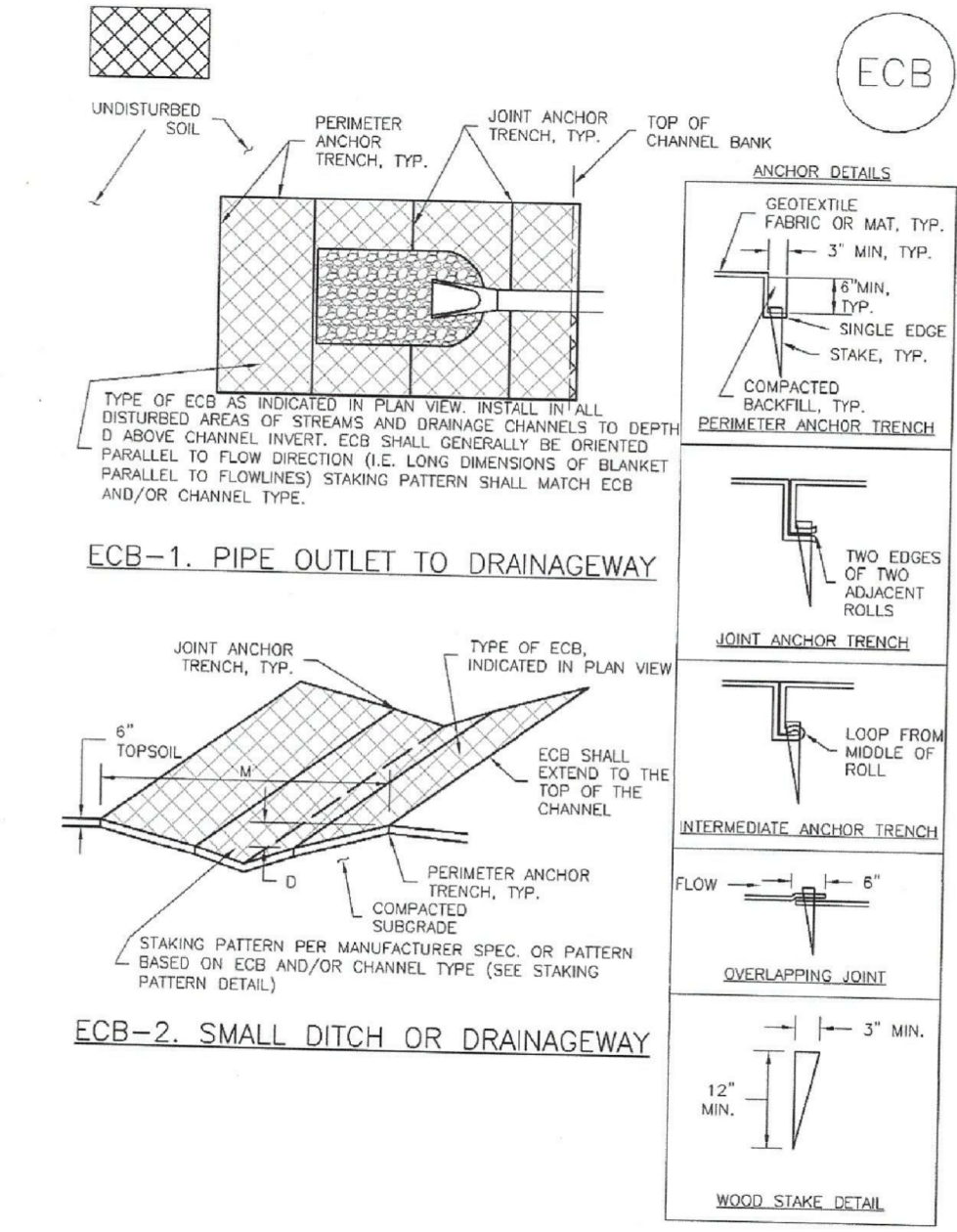

RECP-6 Urban Drainage and Flood Control District Urban Storm Drainage Criteria Manual Volume 3 November 2010

**CORE ENGINEERING GROUP**  
1500 S. AVENUE 35506  
PH: 719.570.1100  
CONTACT: RICHARD L. SCHINDLER, P.E.  
EMAIL: Rich@ceg.com

DATE: \_\_\_\_\_  
DESCRIPTION: \_\_\_\_\_  
NO: \_\_\_\_\_  
PROJECT: CREEKSIDE SOUTH AT LORSON RANCH 2  
LORSON, LLC  
212 N. WAHSATCH AVE, SUITE 301  
COLORADO SPRINGS, COLORADO 80903  
CONTACT: JEFF MARK

DRAWN: RLS  
DESIGNED: RLS  
CHECKED: RLS

GRADING AND EROSION CONTROL DETAILS

Roller Erosion Control Products (RECP) EC-6

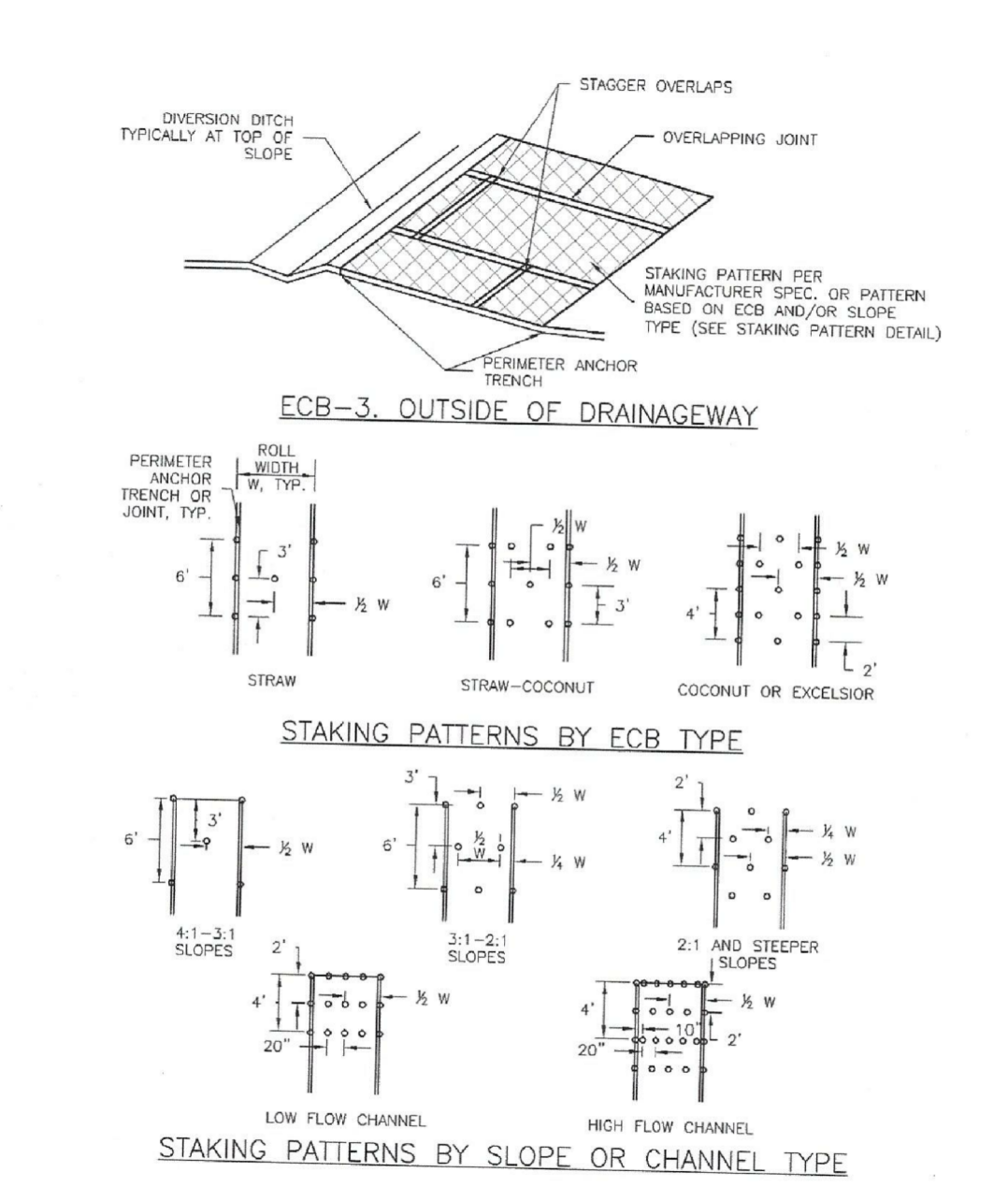

November 2010 Urban Drainage and Flood Control District Urban Storm Drainage Criteria Manual Volume 3 RECP-7



DATE: AUG 24, 2022  
PROJECT NO: 100.069  
SHEET NUMBER: C12.2  
TOTAL SHEETS: 8

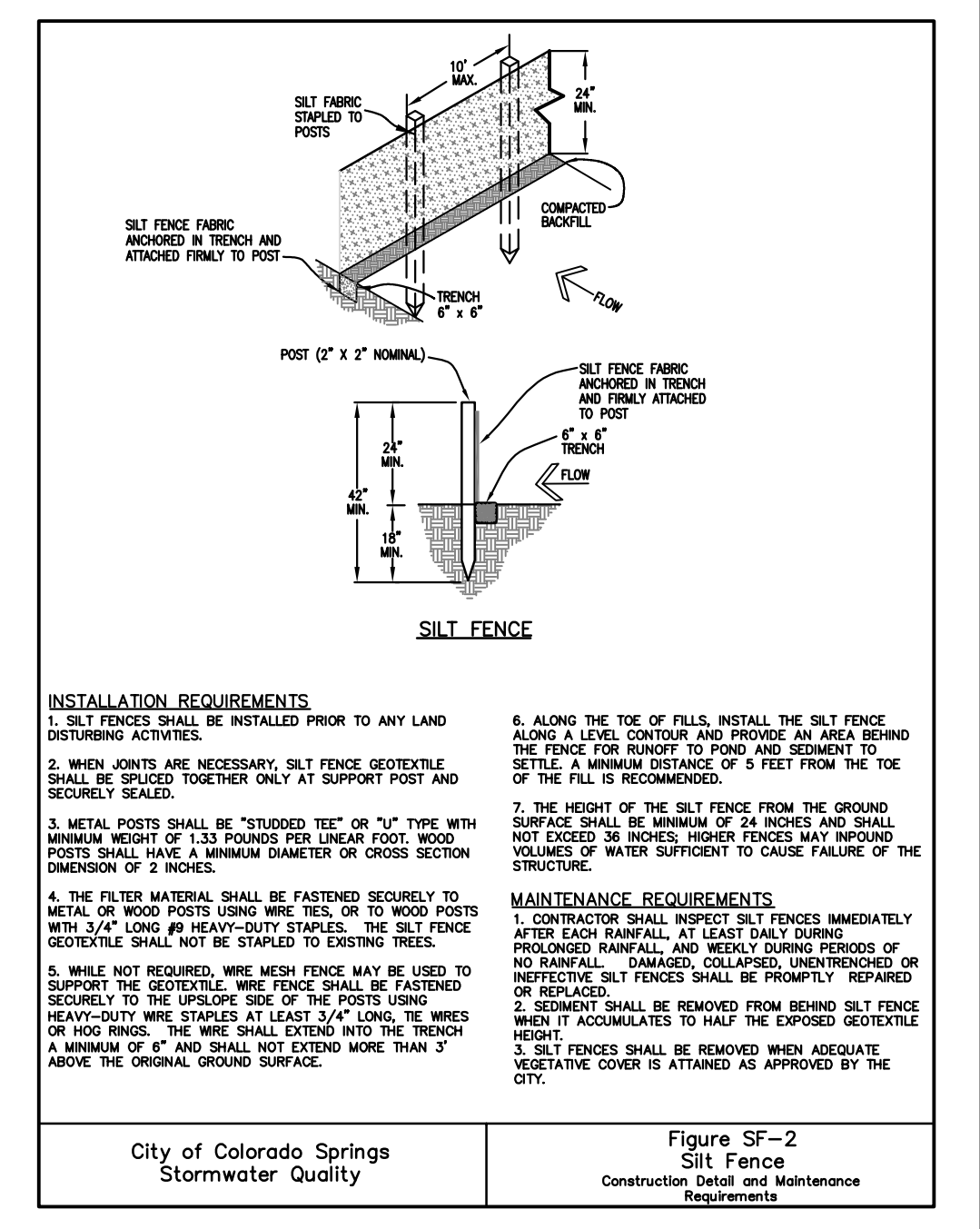

Figure SF-2 Silt Fence Construction Detail and Maintenance Requirements

City of Colorado Springs Stormwater Quality

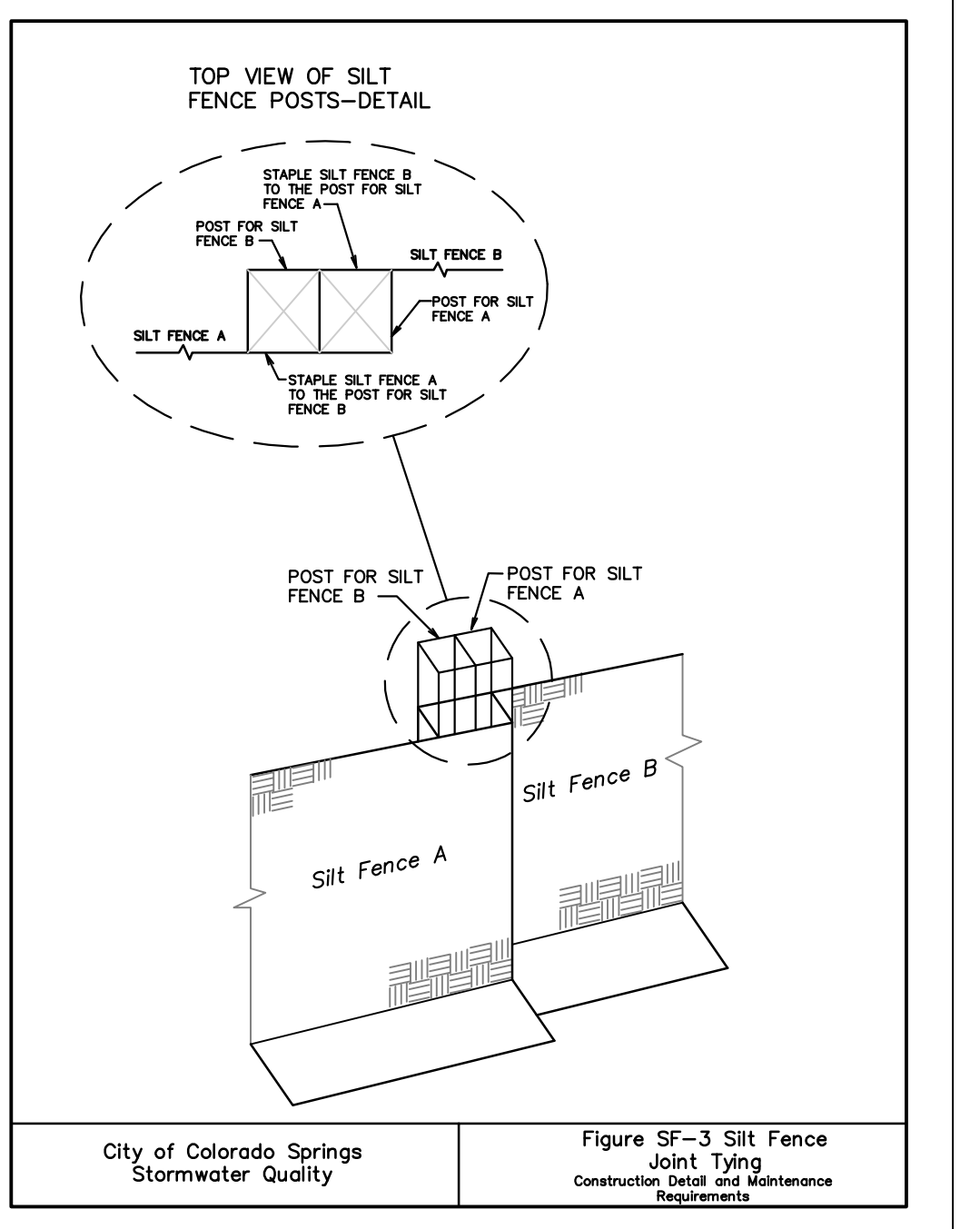

Figure SF-3 Silt Fence Joint Tying Construction Detail and Maintenance Requirements

City of Colorado Springs Stormwater Quality

Required Area per Row (ft<sup>2</sup>)

Depth at Outlet (ft)	Depth at Outlet (ft)									
	1.0	1.5	2.0	2.5	3.0	3.5	4.0	4.5	5.0	5.5
1	15.04	7.71	5.10	3.76	2.85	2.41	2.02	1.73	1.51	1.34
0.8	4.51	2.31	1.53	1.13	0.89	0.72	0.61	0.52	0.45	0.39
0.4	3.01	1.54	1.02	0.75	0.59	0.48	0.40	0.35	0.30	0.26
0.2	1.50	0.77	0.51	0.38	0.30	0.24	0.20	0.17	0.15	0.13
0.1	0.75	0.39	0.26	0.19	0.15	0.12	0.10	0.09	0.08	0.07
0.08	0.45	0.23	0.15	0.11	0.09	0.07	0.06	0.05	0.05	0.04
0.04	0.30	0.15	0.10	0.08	0.06	0.05	0.04	0.03	0.03	0.03
0.02	0.15	0.08	0.05	0.04	0.03	0.02	0.02	0.02	0.02	0.02
0.01	0.08	0.04	0.03	0.02	0.01	0.01	0.01	0.01	0.01	0.01

TABLE SB-1

Circular Perforation Staking

Hole Diameter (in)	Hole Diameter (ft)	Area per Row (ft <sup>2</sup> )		
		n = 1	n = 2	n = 3
1/4	0.250	0.05	0.10	0.15
3/8	0.375	0.08	0.15	0.23
1/2	0.500	0.11	0.22	0.33
5/8	0.625	0.15	0.30	0.45
3/4	0.750	0.20	0.39	0.59
7/8	0.875	0.25	0.50	0.75
1	1.000	0.31	0.61	0.92
1 1/8	1.125	0.37	0.74	1.11
1 1/4	1.250	0.44	0.88	1.33
1 3/8	1.375	0.60	1.20	1.80
1 1/2	1.500	0.79	1.57	2.36
1 5/8	1.625	0.99	1.99	2.98
1 3/4	1.750	1.23	2.45	3.68
1 7/8	1.875	1.48	2.97	4.45
2	2.000	1.77	3.53	5.30
		2.07	4.15	6.22
		2.41	4.81	7.22
		2.76	5.52	8.28
		3.14	6.28	9.42

TABLE SB-2

Minimum steel plate thickness 1/4" 5/16" 3/8"

City of Colorado Springs Stormwater Quality

Figure SB-2 Outlet Sizing Application Techniques and Maintenance Requirements



**EC-2 Temporary and Permanent Seeding (TS/PS)**

Table TS/PS-2. Minimum Drill Seeding Rates for Perennial Grasses

Common Name	Botanical Name	Growth Season	Growth Form	Seeds/Pound	Pounds of PLS/acre
<b>Alkali Soil Seed Mix</b>					
Alkali sacaton	<i>Sporobolus airoides</i>	Cool	Bunch	1,750,000	0.25
Basin wildrye	<i>Elymus cinereus</i>	Cool	Bunch	165,000	2.5
Sodar streambank wheatgrass	<i>Agropyron riparium 'Sodar'</i>	Cool	Sod	170,000	2.5
Jose tall wheatgrass	<i>Agropyron elongatum 'Jose'</i>	Cool	Bunch	79,000	7.0
Arriba western wheatgrass	<i>Agropyron smithii 'Arriba'</i>	Cool	Sod	110,000	5.5
<b>Total</b>					<b>17.75</b>
<b>Fertile Loamy Soil Seed Mix</b>					
Ephraim crested wheatgrass	<i>Agropyron cristatum 'Ephraim'</i>	Cool	Sod	175,000	2.0
Dural hard fescue	<i>Festuca ovina 'duriuscula'</i>	Cool	Bunch	565,000	1.0
Lincoln smooth brome	<i>Bromus inermis leysii 'Lincoln'</i>	Cool	Sod	130,000	3.0
Sodar streambank wheatgrass	<i>Agropyron riparium 'Sodar'</i>	Cool	Sod	170,000	2.5
Arriba western wheatgrass	<i>Agropyron smithii 'Arriba'</i>	Cool	Sod	110,000	7.0
<b>Total</b>					<b>18.5</b>
<b>High Water Table Soil Seed Mix</b>					
Meadow foxtail	<i>Alopecurus pratensis</i>	Cool	Sod	900,000	0.5
Redtop	<i>Agrostis alba</i>	Warm	Open sod	5,000,000	0.25
Reed canarygrass	<i>Phalaris arundinacea</i>	Cool	Sod	68,000	0.5
Lincoln smooth brome	<i>Bromus inermis leysii 'Lincoln'</i>	Cool	Sod	130,000	3.0
Pathfinder switchgrass	<i>Panicum virgatum 'Pathfinder'</i>	Warm	Sod	389,000	1.0
Alkar tall wheatgrass	<i>Agropyron elongatum 'Alkar'</i>	Cool	Bunch	79,000	5.5
<b>Total</b>					<b>10.75</b>
<b>Transition Turf Seed Mix<sup>1</sup></b>					
Ruchens Canadian bluegrass	<i>Poa compressa 'Ruchens'</i>	Cool	Sod	2,500,000	0.5
Dural hard fescue	<i>Festuca ovina 'duriuscula'</i>	Cool	Bunch	565,000	1.0
Citation perennial ryegrass	<i>Lolium perenne 'Citation'</i>	Cool	Sod	247,000	3.0
Lincoln smooth brome	<i>Bromus inermis leysii 'Lincoln'</i>	Cool	Sod	130,000	3.0
<b>Total</b>					<b>7.5</b>

**Temporary and Permanent Seeding (TS/PS) EC-2**

Table TS/PS-2. Minimum Drill Seeding Rates for Perennial Grasses (cont.)

Common Name	Botanical Name	Growth Season	Growth Form	Seeds/Pound	Pounds of PLS/acre
<b>Sandy Soil Seed Mix</b>					
Blue grama	<i>Bouteloua gracilis</i>	Warm	Sod-forming bunchgrass	825,000	0.5
Camper little bluestem	<i>Schizachyrium scoparium 'Camper'</i>	Warm	Bunch	240,000	1.0
Prairie sandreed	<i>Calamovilfa longifolia</i>	Warm	Open sod	274,000	1.0
Sand dropseed	<i>Sporobolus cryptandrus</i>	Cool	Bunch	5,298,000	0.25
Vaughn sidcoats grama	<i>Bouteloua curtipendula 'Vaughn'</i>	Warm	Sod	191,000	2.0
Arriba western wheatgrass	<i>Agropyron smithii 'Arriba'</i>	Cool	Sod	110,000	5.5
<b>Total</b>					<b>10.25</b>
<b>Heavy Clay, Rocky Foothill Seed Mix</b>					
Ephraim crested wheatgrass <sup>1</sup>	<i>Agropyron cristatum 'Ephraim'</i>	Cool	Sod	175,000	1.5
Oahu Intermediate wheatgrass	<i>Agropyron intermedium 'Oahu'</i>	Cool	Sod	115,000	5.5
Vaughn sidcoats grama <sup>2</sup>	<i>Bouteloua curtipendula 'Vaughn'</i>	Warm	Sod	191,000	2.0
Lincoln smooth brome	<i>Bromus inermis leysii 'Lincoln'</i>	Cool	Sod	130,000	3.0
Arriba western wheatgrass	<i>Agropyron smithii 'Arriba'</i>	Cool	Sod	110,000	5.5
<b>Total</b>					<b>17.5</b>

<sup>1</sup> All of the above seeding mixes and rates are based on drill seeding followed by crimped straw mulch. These rates should be doubled if seed is broadcast and should be increased by 50 percent if the seeding is done using a Brillion Drill or is applied through hydraulic seeding. Hydraulic seeding may be substituted for drilling only where slopes are steeper than 3:1. If hydraulic seeding is used, hydraulic mulching should be done as a separate operation.  
<sup>2</sup> See Table TS/PS-3 for seeding dates.  
<sup>3</sup> If site is to be irrigated, the transition turf seed rates should be doubled.  
<sup>4</sup> Crested wheatgrass should not be used on slopes steeper than 6H to 1V.  
<sup>5</sup> Can substitute 0.5 lbs PLS of blue grama for the 2.0 lbs PLS of Vaughn sidcoats grama.

**Temporary and Permanent Seeding (TS/PS) EC-2**

Seeding dates for the highest success probability of perennial species along the Front Range are generally in the spring from April through early May and in the fall after the first of September until the ground freezes. If the area is irrigated, seeding may occur in summer months, as well. See Table TS/PS-3 for appropriate seeding dates.

Table TS/PS-1. Minimum Drill Seeding Rates for Various Temporary Annual Grasses

Species* (Common name)	Growth Season	Pounds of Pure Live Seed (PLS)/acre	Planting Depth (inches)
1. Oats	Cool	35 - 50	1 - 2
2. Spring wheat	Cool	25 - 35	1 - 2
3. Spring barley	Cool	25 - 35	1 - 2
4. Annual ryegrass	Cool	10 - 15	½
5. Millet	Warm	3 - 15	½ - ¾
6. Sudangrass	Warm	5-10	½ - ¾
7. Sorghum	Warm	5-10	½ - ¾
8. Winter wheat	Cool	20-35	1 - 2
9. Winter barley	Cool	20-35	1 - 2
10. Winter rye	Cool	20-35	1 - 2
11. Triticale	Cool	25-40	1 - 2

<sup>1</sup> Successful seeding of annual grass resulting in adequate plant growth will usually produce enough dead-plant residue to provide protection from wind and water erosion for an additional year. This assumes that the cover is not disturbed or mowed closer than 8 inches.  
 Hydraulic seeding may be substituted for drilling only where slopes are steeper than 3:1 or where access limitations exist. When hydraulic seeding is used, hydraulic mulching should be applied as a separate operation, when practical, to prevent the seeds from being encapsulated in the mulch.  
<sup>2</sup> See Table TS/PS-3 for seeding dates. Irrigation, if consistently applied, may extend the use of cool season species during the summer months.  
<sup>3</sup> Seeding rates should be doubled if seed is broadcast, or increased by 50 percent if done using a Brillion Drill or by hydraulic seeding.

**EC-2 Temporary and Permanent Seeding (TS/PS)**

Table TS/PS-3. Seeding Dates for Annual and Perennial Grasses

Seeding Dates	Annual Grasses (Numbers in table reference species in Table TS/PS-4)		Perennial Grasses	
	Warm	Cool	Warm	Cool
January 1-March 15			✓	✓
March 16-April 30	4	1,2,3	✓	✓
May 1-May 15			✓	
May 16-June 30	4	4,5,6,7		
July 1-July 15		5,6,7		
July 16-August 31				
September 1-September 30		8,9,10,11		
October 1-December 31			✓	✓

**Mulch**  
 Cover seeded areas with mulch or an appropriate rolled erosion control product to promote establishment of vegetation. Anchor mulch by crimping, netting or use of a non-toxic tackifier. See the Mulching BMP Fact Sheet for additional guidance.

**Maintenance and Removal**  
 Monitor and observe seeded areas to identify areas of poor growth or areas that fail to germinate. Reseed and mulch these areas, as needed.

An area that has been permanently seeded should have a good stand of vegetation within one growing season if irrigated and within three growing seasons without irrigation in Colorado. Reseed portions of the site that fail to germinate or remain bare after the first growing season.

Seeded areas may require irrigation, particularly during extended dry periods. Targeted weed control may also be necessary.

Protect seeded areas from construction equipment and vehicle access.

**CORE ENGINEERING GROUP**  
 1500 S. AVENUE 103  
 BOULDER, CO 80506  
 PH: 719.576.1100  
 CONTACT: RICHARD L. SCHINDLER, P.E.  
 EMAIL: Rich@eg1.com

DATE: \_\_\_\_\_  
 DESCRIPTION: \_\_\_\_\_  
 NO. \_\_\_\_\_

PREPARED FOR: **LORSON, LLC**  
 212 N. WAHSATCH AVE, SUITE 301  
 COLORADO SPRINGS, COLORADO 80903  
 CONTACT: JEFF MARK

PROJECT: **CREEKSIDE SOUTH AT LORSON RANCH 2**  
 LORSON BLVD. - TRAPPE DR. COLORADO SPRINGS, COLORADO

DRAWN: RLS  
 DESIGNED: RLS  
 CHECKED: RLS

**Earth Dikes and Drainage Swales (ED/DS) EC-10**

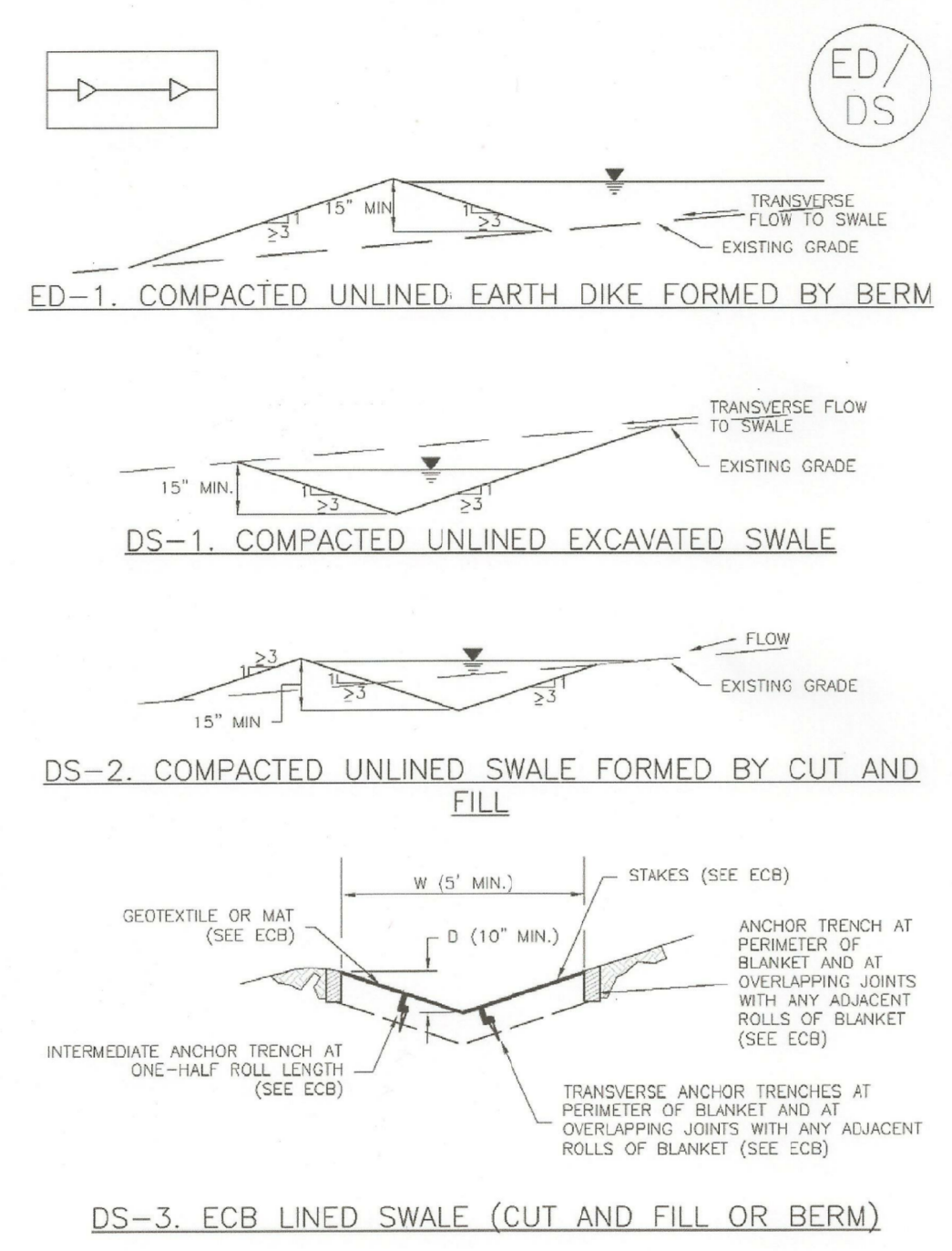

**ST-8 Sediment Trap (ST) November 2010**

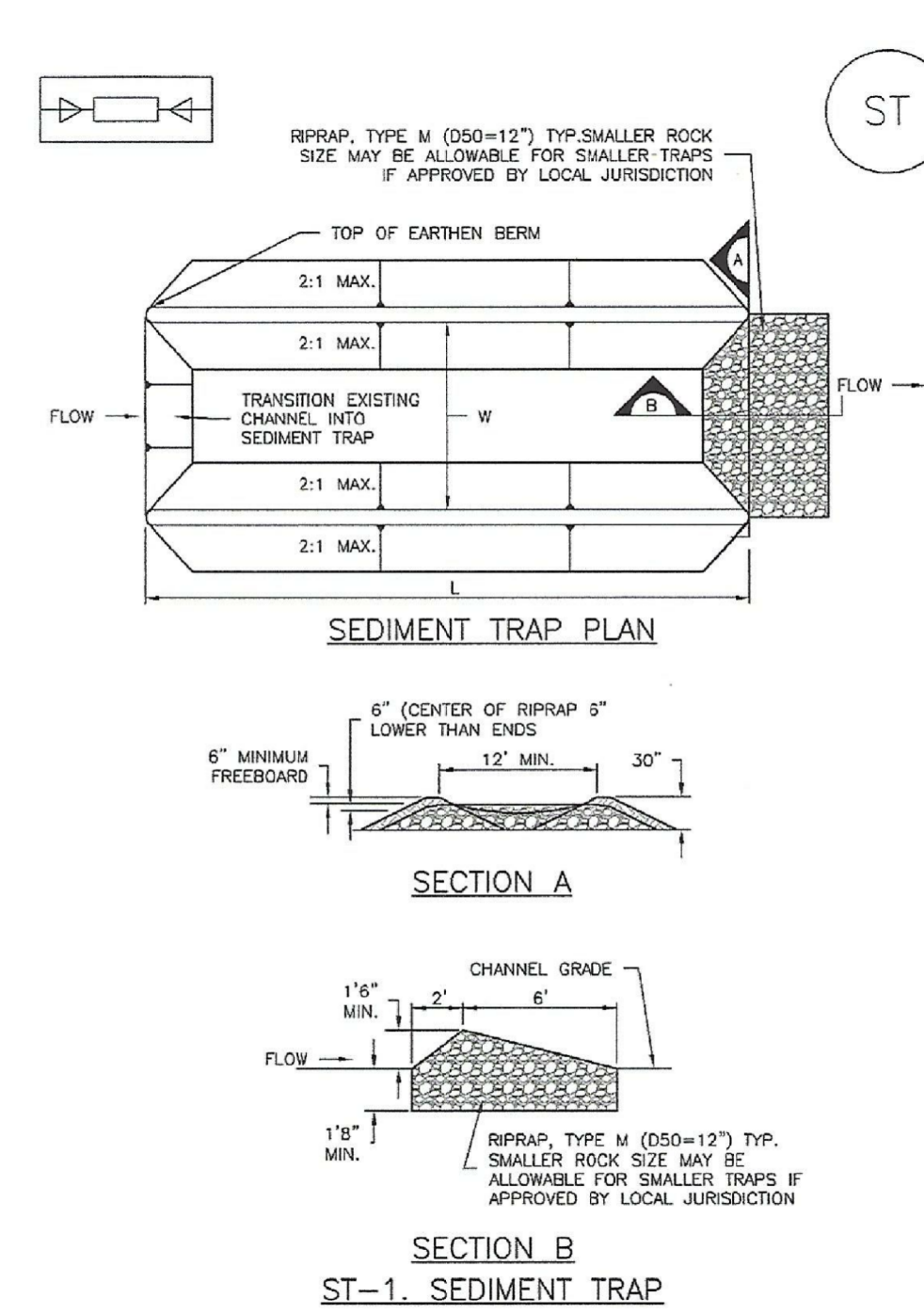

**Stockpile Management (SP) MM-2**

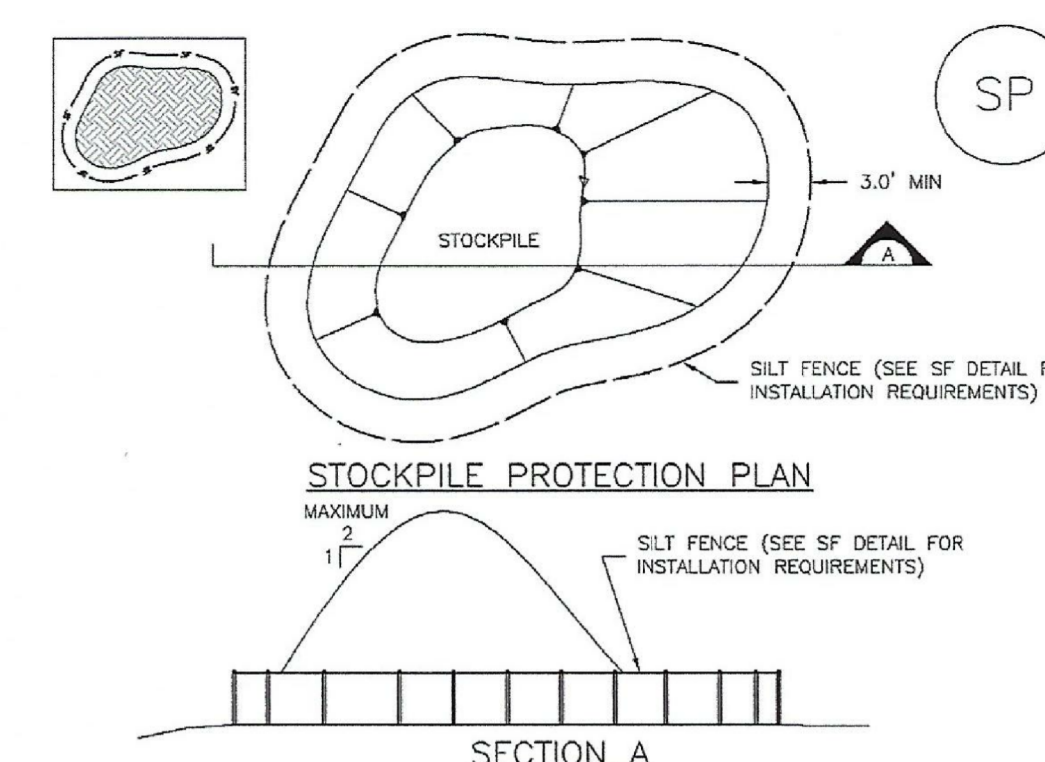

**STOCKPILE PROTECTION INSTALLATION NOTES**

- SEE PLAN VIEW FOR:
  - LOCATION OF STOCKPILES.
  - TYPE OF STOCKPILE PROTECTION.
- INSTALL PERIMETER CONTROLS IN ACCORDANCE WITH THEIR RESPECTIVE DESIGN DETAILS. SILT FENCE IS SHOWN IN THE STOCKPILE PROTECTION DETAILS; HOWEVER, OTHER TYPES OF PERIMETER CONTROLS INCLUDING SEGMENT CONTROL LOGS OR ROCK SOCKS MAY BE SUITABLE IN SOME CIRCUMSTANCES. CONSIDERATIONS FOR DETERMINING THE APPROPRIATE TYPE OF PERIMETER CONTROL FOR A STOCKPILE INCLUDE WHETHER THE STOCKPILE IS LOCATED ON A PERVIOUS OR IMPERVIOUS SURFACE, THE RELATIVE HEIGHTS OF THE PERIMETER CONTROL, AND STOCKPILE, THE ABILITY OF THE PERIMETER CONTROL TO CONTAIN THE STOCKPILE WITHOUT FAILING IN THE EVENT THAT MATERIAL FROM THE STOCKPILE SHIFTS OR SLUMPS AGAINST THE PERIMETER, AND OTHER FACTORS.
- STABILIZE THE STOCKPILE SURFACE WITH SURFACE ROUGHENING, TEMPORARY SEEDING AND MULCHING, EROSION CONTROL BLANKETS, OR SOIL BINDERS. SOILS STOCKPILED FOR AN EXTENDED PERIOD (TYPICALLY FOR MORE THAN 60 DAYS) SHOULD BE SEEDING AND MULCHED WITH A TEMPORARY GRASS COVER ONCE THE STOCKPILE IS PLACED (TYPICALLY WITHIN 14 DAYS). USE OF MULCH ONLY OR A SOIL BINDER IS ACCEPTABLE IF THE STOCKPILE WILL BE IN PLACE FOR A MORE LIMITED TIME PERIOD (TYPICALLY 30-60 DAYS).
- FOR TEMPORARY STOCKPILES ON THE INTERIOR PORTION OF A CONSTRUCTION SITE, WHERE OTHER DOWNGRADE CONTROLS, INCLUDING PERIMETER CONTROL, ARE IN PLACE, STOCKPILE PERIMETER CONTROLS MAY NOT BE REQUIRED.

**Stabilized Staging Area (SSA) SM-6**

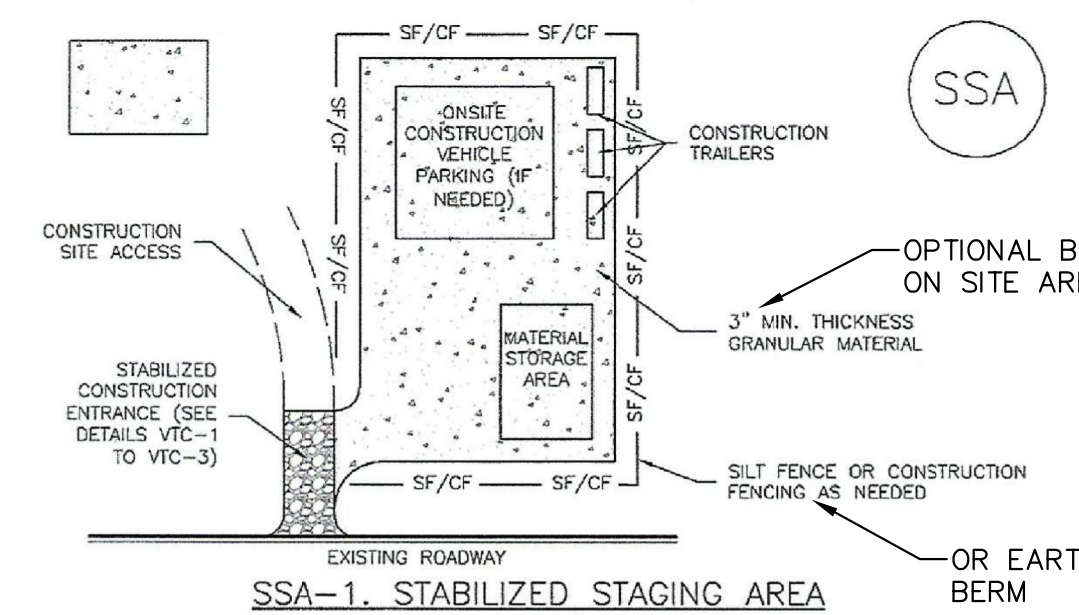

**STABILIZED STAGING AREA INSTALLATION NOTES**

- SEE PLAN VIEW FOR:
  - LOCATION OF STAGING AREA(S).
  - CONTRACTOR MAY ADJUST LOCATION AND SIZE OF STAGING AREA WITH APPROVAL FROM THE LOCAL JURISDICTION.
- STABILIZED STAGING AREA SHOULD BE APPROPRIATE FOR THE NEEDS OF THE SITE. OVERSIZING RESULTS IN A LARGER AREA TO STABILIZE FOLLOWING CONSTRUCTION.
- STAGING AREA SHALL BE STABILIZED PRIOR TO OTHER OPERATIONS ON THE SITE.
- THE STABILIZED STAGING AREA SHALL CONSIST OF A MINIMUM 3" THICK GRANULAR MATERIAL.
- UNLESS OTHERWISE SPECIFIED BY LOCAL JURISDICTION, ROCK SHALL CONSIST OF DOT SECT. #703, AASHTO #3 COARSE AGGREGATE OR 6" (MINUS) ROCK.
- ADDITIONAL PERIMETER BMPs MAY BE REQUIRED INCLUDING BUT NOT LIMITED TO SILT FENCE AND CONSTRUCTION FENCING.

**STABILIZED STAGING AREA MAINTENANCE NOTES**

- INSPECT BMPs EACH WORKDAY, AND MAINTAIN THEM IN EFFECTIVE OPERATING CONDITION. MAINTENANCE OF BMPs SHOULD BE PROACTIVE, NOT REACTIVE. INSPECT BMPs AS SOON AS POSSIBLE (AND ALWAYS WITHIN 24 HOURS) FOLLOWING A STORM THAT CAUSES SURFACE EROSION, AND PERFORM NECESSARY MAINTENANCE.
- FREQUENT OBSERVATIONS AND MAINTENANCE ARE NECESSARY TO MAINTAIN BMPs IN EFFECTIVE OPERATING CONDITION. INSPECTIONS AND CORRECTIVE MEASURES SHOULD BE DOCUMENTED THOROUGHLY.
- WHERE BMPs HAVE FAILED, REPAIR OR REPLACEMENT SHOULD BE INITIATED UPON DISCOVERY OF THE FAILURE.
- ROCK SHALL BE REAPPLIED OR REGRADED AS NECESSARY IF RUTTING OCCURS OR UNDERLYING SUBGRADE BECOMES EXPOSED.

**GRADING AND EROSION CONTROL DETAILS**



DATE: **AUG 24, 2022**

PROJECT NO. **100.069**

SHEET NUMBER **C12.3**

TOTAL SHEETS: **8**



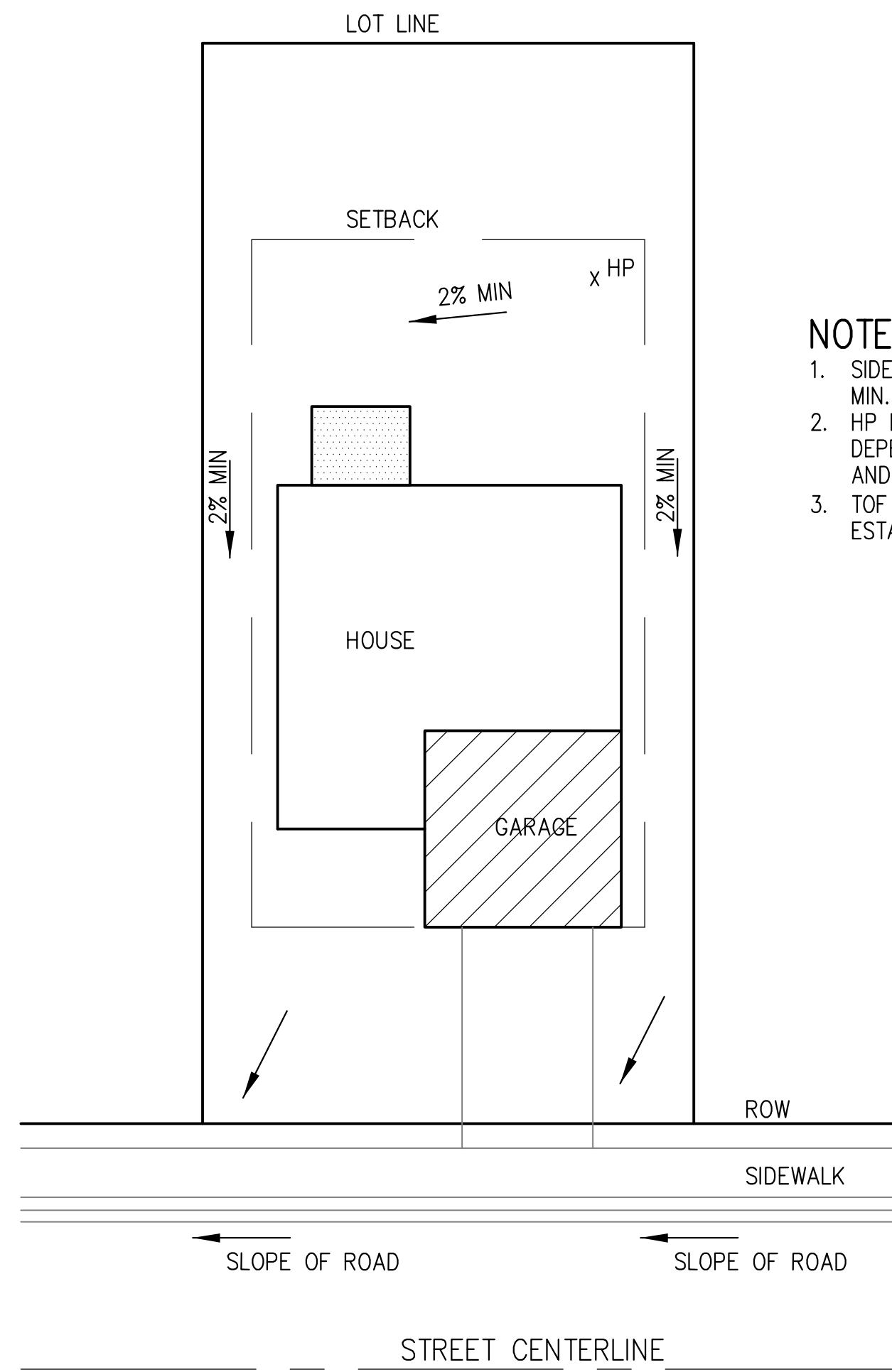

**TYPICAL "A" LOT DRAINAGE PATTERN**  
N.T.S.

**NOTES:**

1. SIDEYARD SWALE TO BE CONSTRUCTED AT 2% MIN. SLOPE.
2. HP LOCATION ON EACH LOT WILL VARY DEPENDING UPON EXACT HOUSE FOOTPRINT AND LOCATION
3. TOF ELEVATION MUST BE MIN. 18" HIGHER THAN ESTABLISHED HP.

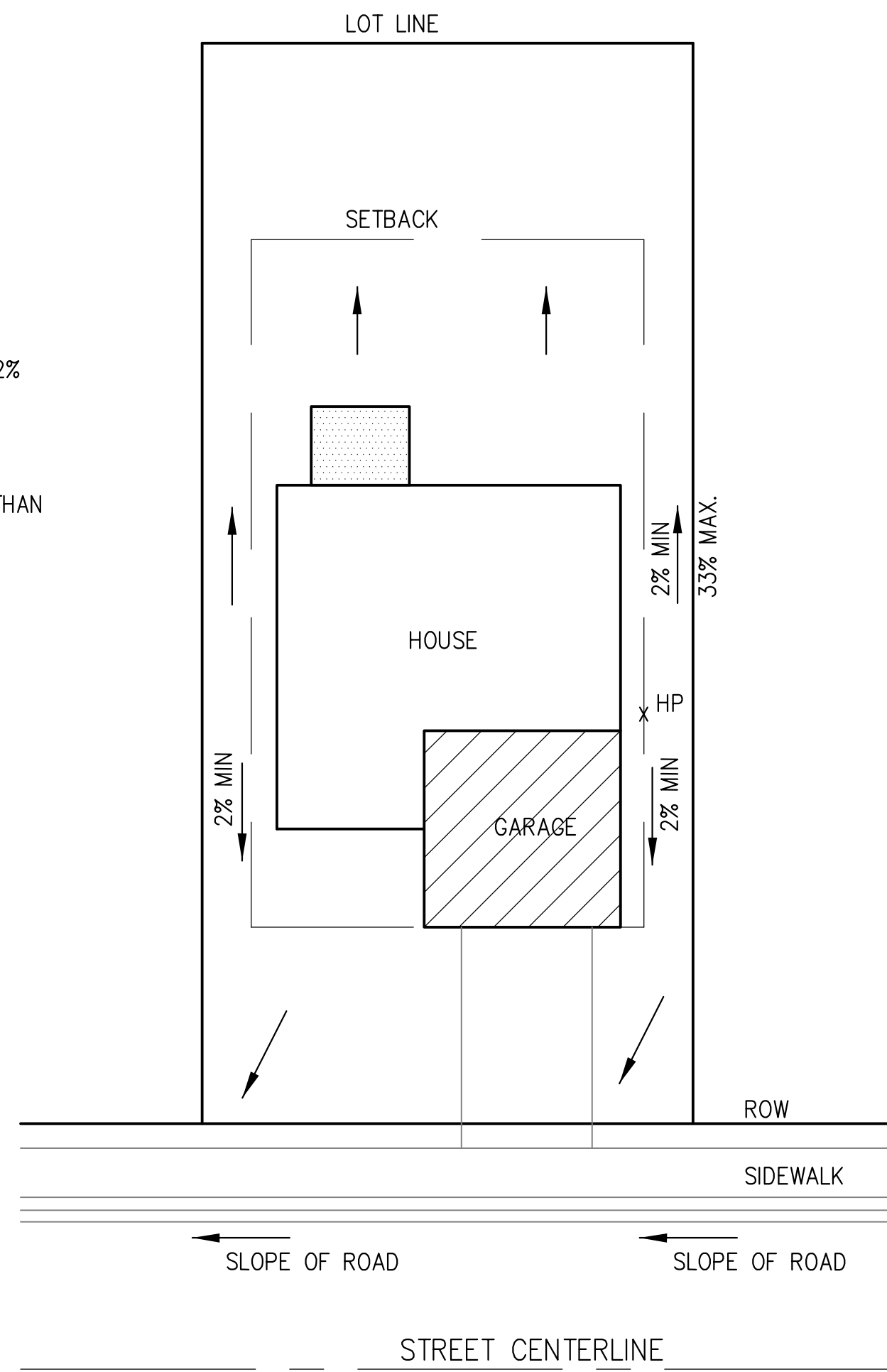

**TYPICAL "B", "G", "W/O" LOT DRAINAGE PATTERN**  
N.T.S.

**MULCHING NOTES**

**INSTALLATION REQUIREMENTS**

1. ALL DISTURBED AREAS MUST BE MULCHED WITHIN 21 DAYS AFTER FINAL GRADE AND SEEDING AREAS ARE TO BE MULCHED WITHIN 24 HOURS AFTER SEEDING.
2. MATERIAL USED FOR MULCH CAN BE CERTIFIED CLEAN, WEED- AND SEED-FREE LONG STEMMED FIELD OR MARSH HAY, OR STRAW OF OATS, BARLEY, WHEAT, RYE, OR TRITICALE CERTIFIED BY THE COLORADO DEPARTMENT OF AGRICULTURE WEED FREE FORAGE CERTIFICATION PROGRAM.
3. HYDRAULIC MULCHING MATERIAL SHALL CONSIST OF VIRGIN WOOD CHIPER MANUFACTURED FROM CLEAN WHOLE WOOD CHIPS. WOOD CHIPS CANNOT CONTAIN ANY GROWTH OR GERMINATION INHIBITORS OR BE PRODUCED FROM RECYCLED MATERIAL. GRAVEL CAN ALSO BE USED.
4. MULCH IS TO BE APPLIED EVENLY AT A RATE OF 2 TONS PER ACRE.
5. MULCH IS TO BE ANCHORED EITHER BY GRIPPING (TUCKING MULCH FIBERS 4 INCHES INTO THE SOIL) USING NETTING (USED ON SMALL AREAS WITH STEEP SLOPES), OR WITH A TACKIFIER.
6. HYDRAULIC MULCHING AND TACKIFIERS ARE NOT TO BE USED IN THE PRESENCE OF FREE SURFACE WATER.

**MAINTENANCE REQUIREMENTS**

1. REGULAR INSPECTIONS ARE TO BE MADE OF ALL MULCHED AREAS.
2. MULCH IS TO BE REPLACED IMMEDIATELY IN THOSE AREAS IT HAS BEEN REMOVED, AND IF NECESSARY THE AREA SHOULD BE RESEEDING.

City of Colorado Springs  
Stormwater Quality

Figure MU-1  
Mulching  
Construction Detail and Maintenance  
Requirements

**SC-3**

**Straw Bale Barrier (SBB)**

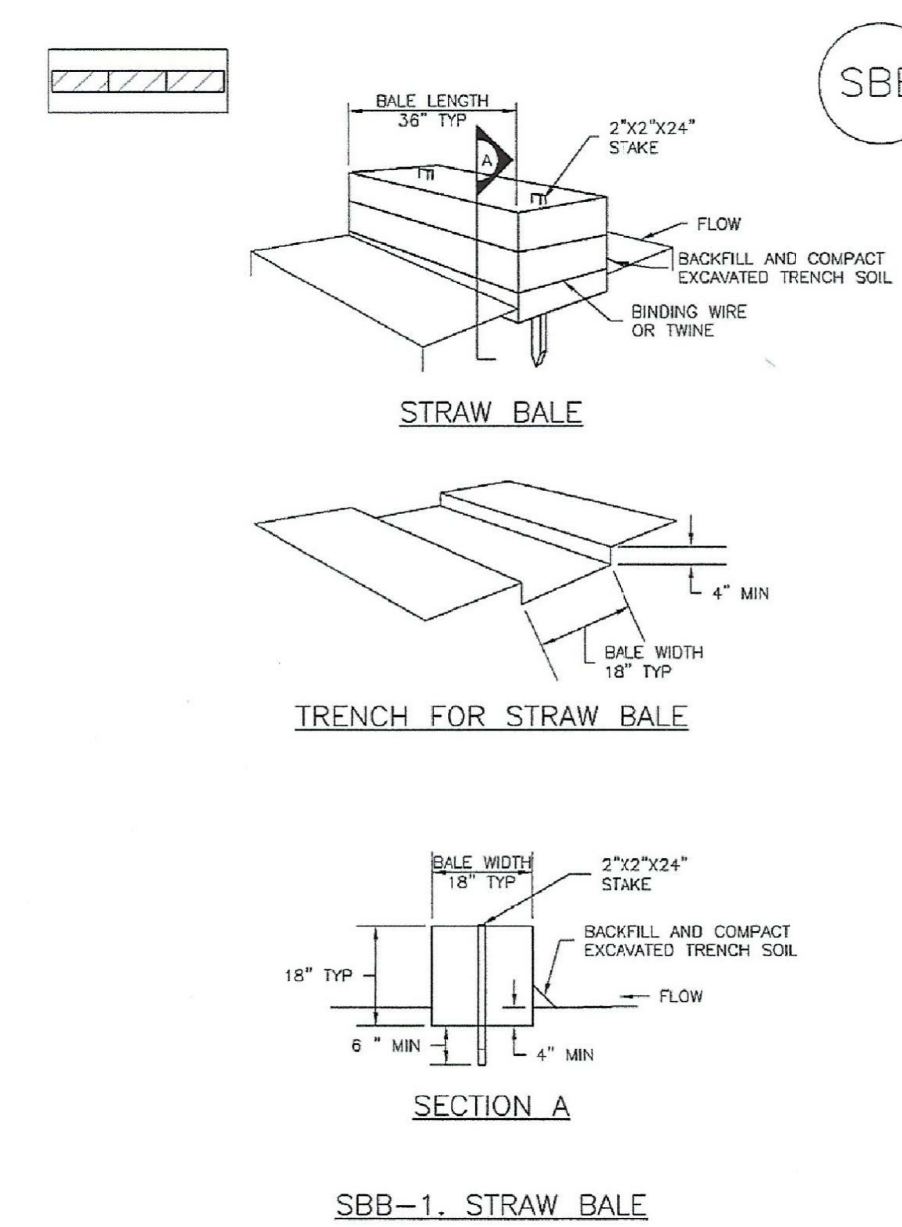

SBB-2

Urban Drainage and Flood Control District  
Urban Storm Drainage Criteria Manual Volume 3

November 2010

**CORE ENGINEERING GROUP**  
1500 S. 1ST AVENUE, SUITE 3506  
DENVER, CO 80202  
PH: 719.570.1100  
CONTACT: RICHARD L. SCHINDLER, P.E.  
EMAIL: Rich@ceg1.com

DATE: \_\_\_\_\_  
DESCRIPTION: \_\_\_\_\_  
NO: \_\_\_\_\_

PREPARED FOR:  
**LORSON, LLC**  
212 N. WAHSATCH AVE, SUITE 301  
COLORADO SPRINGS, COLORADO 80903  
(719) 635-3200  
CONTACT: JEFF MARK

DRAWN: RLS  
DESIGNED: RLS  
CHECKED: RLS

**GRADING AND EROSION CONTROL DETAILS**



DATE:  
AUG 24, 2022

PROJECT NO.  
100.069

SHEET NUMBER  
C12.4

TOTAL SHEETS: 8

**APPENDIX C**

**STORMWATER INSPECTION REPORT**

# Stormwater Inspection Report

Project Name and Location: \_\_\_\_\_

Inspector Name and Title: \_\_\_\_\_ Director: \_\_\_\_\_

Date/Time of Inspection: \_\_\_\_\_ Weather Conditions: \_\_\_\_\_

Schedule Completion Date: \_\_\_\_\_ Construction Stage (circle all that apply):

Clearing/Grubbing Paving Rough Grading Infrastructure Building Construction Final

Grading Final Stabilization Terminate Permit \_\_\_\_\_

Type of Control	Describe status, identify problems, maintenance needs, or non-conformance with details or temporary alteration	Problem addressed (date and description of corrective action)
<b>Structural:</b>		
Silt Fence <input type="checkbox"/> OK <input type="checkbox"/> N/A	<input type="checkbox"/> Tears/Holes <input type="checkbox"/> Burial <input type="checkbox"/> Sed. Accum. <input type="checkbox"/> Sediment bypass	
Const. Exit <input type="checkbox"/> OK <input type="checkbox"/> N/A	<input type="checkbox"/> Voids Filled <input type="checkbox"/> Trackout	
Check Dam <input type="checkbox"/> OK <input type="checkbox"/> N/A	<input type="checkbox"/> Sediment Accumulation	
Inlet Protection <input type="checkbox"/> OK <input type="checkbox"/> N/A	<input type="checkbox"/> Sed. Accum. <input type="checkbox"/> Sed. Bypass <input type="checkbox"/> Application not appropriate	
Diversion Ditch/Berm <input type="checkbox"/> OK <input type="checkbox"/> N/A	<input type="checkbox"/> Erosion <input type="checkbox"/> Stabilization	
Sediment Trap <input type="checkbox"/> OK <input type="checkbox"/> N/A	<input type="checkbox"/> Sediment Accumulation	
Sediment Basin <input type="checkbox"/> OK <input type="checkbox"/> N/A	<input type="checkbox"/> Sed. Accumulation <input type="checkbox"/> Bank erosion <input type="checkbox"/> Stabilization	
Discharge Point <input type="checkbox"/> OK <input type="checkbox"/> N/A	<input type="checkbox"/> Erosion <input type="checkbox"/> Sediment Discharge	
Material Storage/Secondary Contain. <input type="checkbox"/> OK <input type="checkbox"/> N/A	<input type="checkbox"/> Not shown on Site Map <input type="checkbox"/> Spills <input type="checkbox"/> Out of design. area <input type="checkbox"/> Improper storage: chemicals; solvents; paint; fuels, etc.	

Other Structural Controls <input type="checkbox"/> OK <input type="checkbox"/> N/A		
<b>Non-Structural:</b>		
Good Housekeeping <input type="checkbox"/> OK <input type="checkbox"/> N/A	<input type="checkbox"/> Solid Waste <input type="checkbox"/> Sanitary Waste <input type="checkbox"/> Dust Control	

Project Name and Location: \_\_\_\_\_ Date: \_\_\_\_\_ Page 2

Equip. Wash/Maint. <input type="checkbox"/> OK <input type="checkbox"/> N/A	<input type="checkbox"/> Spills <input type="checkbox"/> Outside designated area	
Concrete Washout <input type="checkbox"/> OK <input type="checkbox"/> N/A	<input type="checkbox"/> Spills out of designated area <input type="checkbox"/> Not shown on Site Map	
<b>Stabilization:</b>		
Seed/Sod Mulching, Geotextile, Blankets <input type="checkbox"/> OK <input type="checkbox"/> N/A	<input type="checkbox"/> Need Temp. stab. <input type="checkbox"/> Need final stab. <input type="checkbox"/> Health of veg.	
<b>Record Keeping:</b>		
Entrance Postings <input type="checkbox"/> OK <input type="checkbox"/> N/A	<input type="checkbox"/> NOI <input type="checkbox"/> Permits <input type="checkbox"/> Construction Site Notice	
SWPPP Notebook <input type="checkbox"/> OK <input type="checkbox"/> N/A	<input type="checkbox"/> Missing Sections <input type="checkbox"/> Missing Forms	
Site Map/Details <input type="checkbox"/> OK <input type="checkbox"/> N/A	<input type="checkbox"/> Activities not up-to-date <input type="checkbox"/> Deviate from details <input type="checkbox"/> BMP Additions <input type="checkbox"/> Modifications <input type="checkbox"/> Not up-to-date	
Other <input type="checkbox"/> OK <input type="checkbox"/> N/A		

I certify under penalty of law that this document and all attachments were prepared under my direction or supervision in accordance with a system designed to assure that qualified personnel properly gathered and evaluated the information submitted. Based on my inquiry of the person or persons who manage the system, or those persons directly responsible for gathering the information, the information is, to the best of my knowledge and belief, true, accurate, and complete. I am aware that there are significant penalties for submitting false information, including the possibility of fine and imprisonment for knowing violations.

\_\_\_\_\_  
Inspector's Signature

Date

**APPENDIX D**

**SPILL REPORT FORM**



## Spill Report Form

Project Type and Location: \_\_\_\_\_

Spill Reported by: \_\_\_\_\_

Date/Time Spill: \_\_\_\_\_

Describe spill location and events leading to spill: \_\_\_\_\_

\_\_\_\_\_

Material spilled: \_\_\_\_\_

Source of spill: \_\_\_\_\_

Amount spilled: \_\_\_\_\_ Amount spilled to waterway: \_\_\_\_\_

Containment or clean up action: \_\_\_\_\_

\_\_\_\_\_

Approximate depth of soil excavation: \_\_\_\_\_

List Injuries or Personal Contamination: \_\_\_\_\_

Action to be taken to prevent future spills: \_\_\_\_\_

\_\_\_\_\_

Modifications to the SWPPP necessary due to this spill: \_\_\_\_\_

\_\_\_\_\_

Agencies notified of the spill: \_\_\_\_\_

\_\_\_\_\_

I certify under penalty of law that this document and all attachments were prepared under my direction or supervision in accordance with a system designed to assure that qualified personnel properly gather and evaluate the information submitted. Based on my inquiry of the person or persons who manage the system, or those persons directly responsible for gathering the information, the information submitted is, to the best of my knowledge and belief, true, accurate, and complete. I am aware that there are significant penalties for submitting false information, including the possibility of fine and imprisonment for knowing violations.

\_\_\_\_\_  
Contractor Superintendent

\_\_\_\_\_  
Date

**APPENDIX E**

**RECORD OF STABILIZATION AND  
CONSTRUCTION ACTIVITY DATES**

# **SITE STABILIZATION and CONSTRUCTION ACTIVITY DATES**

A record of dates when BMPs are installed or removed, stabilization measures are initiated, major grading activities occur, and construction activities temporarily or permanently cease on a portion of the site shall be maintained until final site stabilization is achieved.

## **MAJOR STABILIZATION AND GRADING ACTIVITIES**

Description of Activity: \_\_\_\_\_

Site Contractor: \_\_\_\_\_ Begin (date): \_\_\_\_\_  
End(date): \_\_\_\_\_

Location: \_\_\_\_\_

\_\_\_\_\_

\_\_\_\_\_

\_\_\_\_\_

\_\_\_\_\_

Description of Activity: \_\_\_\_\_

Site Contractor: \_\_\_\_\_ Begin (date): \_\_\_\_\_  
End(date): \_\_\_\_\_

Location: \_\_\_\_\_

\_\_\_\_\_

\_\_\_\_\_

\_\_\_\_\_

\_\_\_\_\_

\_\_\_\_\_

Description of Activity: \_\_\_\_\_

Site Contractor: \_\_\_\_\_ Begin (date): \_\_\_\_\_  
End(date): \_\_\_\_\_

Location: \_\_\_\_\_

\_\_\_\_\_

\_\_\_\_\_

**APPENDIX F**

**FEDERAL, STATE, OR LOCAL STORM WATER OR OTHER  
ENVIRONMENTAL INSPECTOR SITE VISIT LOG**

# Federal, State, or Local Storm Water or other Environmental Inspector Site Visit Log

Inspectors Name: \_\_\_\_\_ Agency: \_\_\_\_\_

Contractors Representative Present: \_\_\_\_\_

Others Present: \_\_\_\_\_

Comments: \_\_\_\_\_

Time and Date: \_\_\_\_\_ Report Prepared:  
Yes No

Inspectors Name: \_\_\_\_\_ Agency: \_\_\_\_\_

Contractors Representative Present: \_\_\_\_\_

Others Present: \_\_\_\_\_

Comments: \_\_\_\_\_

Time and Date: \_\_\_\_\_ Report Prepared:  
Yes No

Inspectors Name: \_\_\_\_\_ Agency: \_\_\_\_\_

Contractors Representative Present: \_\_\_\_\_

Others Present: \_\_\_\_\_

Comments: \_\_\_\_\_

Time and Date: \_\_\_\_\_ Report Prepared:  
Yes No

**APPENDIX G**  
**GENERAL PERMIT**