

STORMWATER MANAGEMENT PLAN (SWMP)

FOR

Aura at Crossroads

November 1st, 2021

Prepared for:

Trinsic Acquisition Company, LLC

8235 Douglas Avenue, Suite 950
Dallas, TX 75225
Phone: 970-819-9968

Prepared by:



John O'Rourke, P.E.
1120 Lincoln Street, Suite 1000
Denver, CO 80203
Ph: 303-623-6300, Fax: 303-623-6311

Harris Kocher Smith Project No.: 200823
PCD Project Number: PPR-21-041

Qualified Stormwater Manager:

Name: John O'Rourke
Company: Harris Kocher Smith
Address: 1120 Lincoln Street, Denver, CO 80203

Contractor:

Name: Ryan Halla
Company: CSI Construction Company
Address: 540 Elkton Drive, Suite 202,
Colorado Springs, CO 80907

TABLE OF CONTENTS

I.	Stormwater Quality Statement.....	2
II.	Location.....	2
III.	Nature of Construction Activity	2
IV.	Sequence of Major Activities	2
V.	Estimates of Site Area	3
VI.	Summary of Existing Data	3
VII.	Existing Vegetation.....	4
VIII.	Potential Pollution Sources.....	4
IX.	Potential Non-Stormwater Discharges.....	4
X.	Soil Erosion Potential	4
XI.	Receiving Water(s)	5
XII.	Construction Schedule	5
XIII.	Stormwater Management Considerations	5
XIV.	Erosion and Sediment Control Measures (BMP's)	6
XV.	SWMP Administrator	8
XVI.	Potential Pollution Sources.....	8
XVII.	Final Stabilization and Long-Term Stormwater Management.....	12
XVIII.	Inspection and Maintenance.....	12
XIX.	Conclusion.....	13
XX.	References	13
	APPENDIX A – Vicinity Map, FIRM Map.....	15
	APPENDIX B – Geotechnical Report & Soils Information.....	16
	APPENDIX C – Standard Operating Procedures	17
	APPENDIX D – Erosion Control Plan.....	18

CONTACT INFORMATION

Applicant:

Company Name: Trinsic Acquisition Company, LLC
Email: ajones@trinsicres.com
Mailing Address: 8235 Douglas Avenue, Suite 950
Dallas, TX 75225
Telephone #: (970) 819-9968

Local Contact/Project Manager:

Name: Allison Jones
Email: ajones@trinsicres.com
Mailing Address: 1801 Wewatta Street, Floor 11
Denver, CO 80202
Telephone # O: (970) 819-9968
C: TBD

Plan Preparation Consultant:

Company Name: Harris Kocher Smith
Professional Engineer: John O'Rourke
Email: jorourke@hkseng.com
Mailing Address: 1120 Lincoln Street, Suite 1000
Denver, CO 80203
Telephone # (303) 623-6300
Fax # (303) 623-6311

I. Stormwater Quality Statement

Stormwater quality best management practices shall be implemented to minimize soil erosion, sedimentation, increased pollutant loads and changed water flow characteristics resulting from land disturbing activity, to the maximum extent practicable, so as to minimize pollution of receiving waters.

II. Location

The proposed Aura at Crossroads development (Site) is located within the County of El Paso. The Site is bound by the Seasons at Meadowbrook Crossing development to the north, undeveloped land to the east, Highway 24 to the south, and undeveloped land to the west. The Site is located approximately 38 degrees 50 minutes 32.9 seconds North latitude and 104 degrees 41 minutes 46.6 seconds West longitude. More specifically, the Site is situated in the southwest quarter of section 8, Township14 South, Range 65 West of the 6th Principal Meridian, County of El Paso, State of Colorado. The Site is comprised of 12.70 acres of undeveloped land. A Vicinity Map is attached in Appendix A.

III. Nature of Construction Activity

The Site is being developed into ten buildings, surface parking and associated drive lanes, open space, landscaping, and hardscape. The buildings will be one multi-story clubhouse with a pool, an amenity building, and eight buildings containing three-stories of residential apartments. The buildings on site are anticipated to contain 306 dwelling units, amenity space, and associated hardscape and landscaping. Private storm sewer will be constructed to convey nearly all on-site flows. The on-site flow collected by the private storm sewer will be released into the existing Water Quality/Detention Pond south of Building 6 and the dog park.

The currently undeveloped land located within the property line will be utilized to stage equipment and to temporarily stockpile soil. BMP placement and site layout are detailed on sheets 2-4 of the GEC in appendix D.

IV. Sequence of Major Activities

The proposed sequence for major activities is described in detail in the Stormwater Management Considerations section below.

V. Estimates of Site Area

The Site is approximately 12.70 acres, with additional construction area to the east of the Site in Tract C that will bring the total disturbed area to 13.67 acres. Tract C will be a roadway section for site access developed during Site construction. The entire Site will be disturbed by excavation, grading, utility installation and other construction activities. The exact limits of disturbance are shown on the GEC plans included in Appendix D.

VI. Summary of Existing Data

Currently, the Site is undeveloped except for minor dirt roads that will be removed in over lot grading prior to project commencement. The Site generally slopes toward the east and south of the site, with minor grade changes along the western edge at the property line. There are no streams that cross the project area.

According to the *Geotechnical Investigation* prepared by CTL Thompson, Inc., dated May 18, 2021, borings on the Site generally encountered negligible topsoil. Subsurface soils encountered at the boring locations generally consisted of 20-30 feet of sand and silty sand soils. The soils encountered were loose to very dense, based on the results of field penetration resistance levels. Sandstone bedrock was encountered in one boring at a depth of 29 feet, and groundwater was not encountered in any of the borings. Please refer to the geotechnical report in Appendix B for more information.

There are two soil types as identified by the Natural Resource Conservation Service (NRCS) web soil survey (see Table 1 below & Appendix B). The NRCS classifies the Site soil to be in hydrological soil group A and B. Type A soils are characterized as having a high infiltration rate when wetted and high erosion potential. Type B soils are characterized as moderately draining when wetted and having moderate erosion potential.

Map Unit Name	Acres in AOI	Hydrological Soil Group	Percent of AOI
Blakeland Loamy Sand, 1 to 9% slopes	16.7	A	96.6%
Blendon Sandy Loam, 9 to 15% slopes	0.6	B	3.4%
Totals for Area of Interest	17.2		100.0%

Table 1: Soil Map Data (Courtesy NRCS)

The Site is shown on the Federal Emergency Management Agency's (FEMA) Flood Insurance Rate Map (FIRM) Map Number 08041C0754G, effective as of December 07, 2018. A current FIRMette of the site is attached in Appendix A.

VII. Existing Vegetation

The Site is covered with a slight to moderate stand of mostly grasses and weeds and scattered trees. The parcel is crisscrossed by several narrow, dirt paths. Vegetation coverage is estimated at 90%. The existing vegetation should be inspected prior to construction and cataloged to compare with post construction vegetation. There are no known wetlands on site.

VIII. Potential Pollution Sources

The location and description of all potential pollution sources, including ground surface disturbing activities, vehicle fueling, storage of fertilizers or chemicals, etc. is detailed below in the Potential Pollution Sources Section.

IX. Potential Non-Stormwater Discharges

Non-stormwater components of discharge, such as underground springs and landscape irrigation return flow are not anticipated to occur with this development. However, the contractor shall be responsible to monitor for such discharges and notify the engineer in such an event. If construction dewatering is necessary, the contractor shall be responsible for ensuring a construction dewatering permit is obtained prior to discharging water to surface water or storm sewer systems.

X. Soil Erosion Potential

The proposed construction activities anticipate the potential for soil erosion, particularly with the presence of collapse-prone soils at the southern half of the site. BMP management practices are proposed to minimize in soil erosion.

XI. Receiving Water(s)

The ultimate receiving water for the Site is Sand Creek. The site will drain to the proposed stormwater system inlets shown on the GEC plan sheets 3 and 4 attached in Appendix D. The on-site stormwater system will convey collected runoff to the existing water quality/detention pond to the south of the site. The water quality/detention pond then discharges to the receiving water at a controlled historic rate. There are no major drainageways, irrigation facilities, or known wetlands on or adjacent to this Site.

XII. Construction Schedule

Construction on this Project is scheduled to commence in spring of 2022 and the anticipated completion and final stabilization will be in the winter of 2023. Construction BMP's for the entire Site shall be installed according to the GEC plans in Appendix D.

XIII. Stormwater Management Considerations

Stormwater management for the Site will be accomplished in the following Phases:

Phase 1 – Initial: Prior to earth disturbances

- Construction Fence (CF)
- Vehicle tracking control (VTC)
- Concrete washout (CWA) area installation
- Silt Fence (SF) installation
- Stabilized Staging Area installation
- Temporary Soil Stockpile (SP) area installation

Phase 2 - Interim: During and immediately after earth disturbances

- Maintenance of the previously installed measures
- Roadway inspection and any necessary cleanup each day
- Surface roughening where necessary
- Seeding and Mulching
- Inlet Protection (IP) at proposed inlets (Refer to GEC Plans)

BMP's will be installed on the Site as shown on sheet 2-4 of the GEC, found in Appendix D. Excess soil generated during construction activities on the Site will be hauled to and temporarily stockpiled at the soil stockpile area.

Following final haul off and disposal of excess soil generated on Site and temporarily stockpiled at the Stockpile Area, areas of the stockpile area disturbed by staging and stockpiling will be restored by seeding and mulching.

- Phase 3 – Final: After paving, foundation construction and underground utility construction
- Maintenance of the previously installed measures
- Removal of concrete washout area
- Installation of formal landscaping
- Request for final inspection
- Upon inspection approval, removal of temporary measures

XIV. Erosion and Sediment Control Measures (BMP's)

The following BMP's shall be implemented as indicated, prior to and during construction activities on the Site. This plan indicates the purpose of and estimated timing of implementation of such BMP's. The contractor's representative shall be vigilant in ensuring that additional BMP placement is implemented immediately in the event of deficiencies of any unforeseen erosion conditions. Contractor shall be responsible for ensuring BMPs are in place as warranted by field conditions to treat stormwater as required by El Paso County and Cherokee Metro District during utility construction within R.O.W.

Silt Fence

Silt fence is to be utilized along the entire perimeter of the Site and soil stockpiles. Silt fence shall be placed along the contour, at the base of any disturbed area, as shown on the Stormwater Management Plan. When silt fence is not installed along the contour, a "J-Hook" installation may be appropriate to ensure that the BMP does not create concentrated flow parallel to the silt fence. Rock socks may be substituted for silt fence as perimeter control on hard surface areas.

Inlet Protection

All storm sewer inlets that are made operable during construction or previously exist adjacent to, or located within the Site, must be protected to prevent sediment-laden runoff from entering the storm sewer system. Inlet protection locations are indicated on the GEC Plans sheets 2-4. Inlet protection measures may be removed after upstream areas are stabilized.

Vehicle Tracking Control

A vehicle tracking control area will be installed at the location shown on the SWMP. All construction traffic will be required to pass through this area in order to limit the amount of sediment transported to public roadways. Whenever sediment is transported onto a public road, the road shall be cleaned immediately. Sediment shall be removed by shoveling, sweeping, or other approved methods. Street washing is not allowed.

Dust Mitigation

The contractor shall have measures on site during grading to mitigate airborne dust pollutants. Water trucks shall be used to moisten soil access drives to reduce the amount of dust particles created by wind and on-site construction traffic.

Concrete Washout Area

A concrete washout area is identified on the SWMP. The concrete washout can be earth built or portable. The concrete washouts shall be maintained in effective operational condition and built to spec per the City of Colorado Springs.

Stabilized Staging Area

A Stabilized Staging Area (used for equipment storage, parking, and a loading/unloading zone) is identified on the SWMP. It is located on the north side of the site near the construction entrance.

Seeding and Mulching

All disturbed areas shall be seeded and mulched within 21 days of initial exposure, or 7 days after grading is substantially complete in each area. All disturbed areas shall be seeded and mulched per El Paso County's criteria.

Surface Roughening

Surface roughening provides temporary stabilization of disturbed areas from water and wind erosion. The soil surface is considered to be roughened if depressions are created two to six inches deep and are spaced approximately six inches apart. Surface roughening shall be performed on all disturbed and graded areas of the Site (except in areas where buildings, pavement, or sod are to be placed within 7 days). Surface Roughening should follow along the contours of the slope. Care should be taken not to allow vehicles on treated slopes, as tire tracks will smooth the roughened surface and encourage runoff to collect into channels.

XV. Qualified Stormwater Manager (QSM)

The QSM must be sufficiently qualified for the required duties per the ECM Appendix I.5.2.A.

- The QSM is responsible for implementing and maintaining the Stormwater Management Plan.
- The QSM shall contact the engineer of record for development and revisions of the SWMP.
- The QSM shall be responsible for reporting spills.
- The QSM shall conduct Site inspections and shall verify that repairs to the BMPs have been completed and certify corrections.
- The QSM shall conduct BMP training.

XVI. Potential Pollution Sources

Disturbed and Stored Soils

Disturbed and stored soils are a potential pollution source for the Site. Implementing dust mitigation, rock socks, silt fence, and sediment control logs will control the disturbed and stored soils.

Vehicle Tracking of Sediments

Vehicle tracking of sediments is a potential pollution source for the Site and will be controlled by vehicle tracking control pads located at the construction entrances.

Management of Contaminated Soil

The contractor shall be responsible to monitor for contaminated soils and notify the engineer, El Paso County Dispatch, and Colorado Department of Public Health and Environment (CDPHE) if discovered.

While no pre-existing contaminants were found in the soil, the aforementioned fill material underlying the surface paving is determined to be unstable and will need to be addressed during construction. There are soils that certify as collapsible-prone on the southern portion of the site and will require sub-excavation and remediation up to four feet. For more information, refer to the Geotechnical Engineering Study in Appendix B.

Stained areas should be further evaluated, and any impacted soils should be properly disposed of off-site. The contractor will be responsible for monitoring for contamination throughout construction and any required remediation will occur immediately. The contractor shall be responsible for monitoring excavation and notify the engineer, El Paso County Dispatch, and CDPHE if any contaminated soils or underground storage tanks are discovered.

Loading and Unloading Operations

Loading and unloading operations is a potential pollution source for the Site. Loading and unloading operations shall take place within the stabilized staging area.

Outdoor Storage Activities

Outdoor storage activities are a potential pollution source for the Site. Materials sometimes used at a construction site present a potential for contamination of stormwater runoff. These may include, but are not limited to: building materials, fuel, oil, lubricants, paints, solvents, concrete curing compounds, pesticides, fertilizers, chemicals, herbicides, etc. The contractor shall designate an area where these products should be stored in an enclosure, container, or lined earthen dike, constructed to prevent discharge of these materials in runoff from the Site. These barriers will also function to contain spilled

materials from contact with surface runoff. Standard Operating Procedures (SOP) for material spill containment and clean-up are provided in Appendix C.

Vehicle and Equipment Maintenance and Fueling

Vehicle and equipment maintenance and fueling is a potential pollution source for the Site. Measures shall also be taken to prevent spills or leaks of fuel, oils, lubricants, antifreeze, and other contaminant fluids from construction vehicles to protect groundwater and stormwater runoff. All equipment maintenance shall be performed in a designated area, and measures such as drip pans shall be used to contain petroleum products. Spills of construction materials should be cleaned up immediately and disposed of properly. The contractor shall routinely inspect equipment for leaks that could lead to discharge of petroleum products into surface runoff.

Dust or Particulate Generating Processes

Significant dust or particulate generating processes are not a potential pollution source for the Site; however minor dust or particulate may be generated during the grading process. Dust mitigation, surface roughening, and seeding and mulching shall be implemented to mitigate airborne dust pollutants.

Routine Maintenance Activities

Routine maintenance activities are a potential pollution source for the Site. The contractor shall designate an area where these practices occur and shall routinely inspect and maintain areas to eliminate the pollution source.

On-Site Waste Management Practices

On-site waste management practices (waste piles, liquid wastes, dumpsters, etc.) are a potential pollution source for the Site. The contractor shall designate an area where these practices occur and shall routinely inspect and maintain the areas to eliminate the pollution source.

Concrete Truck/Equipment Washing

Concrete truck and equipment washing is a potential pollution source for the Site and should only occur at the designated Concrete Washout Area shown on the SWMP.

Dedicated Asphalt and Concrete Batch Plants

Dedicated asphalt and concrete batch plants are not a potential pollution source for the Site. There will not be any dedicated concrete or asphalt batch plants on site.

Non-Industrial Waste Sources

Non-industrial waste sources such as worker trash and portable toilets are a potential pollution source for the Site. The contractor shall designate an area where these practices occur and shall routinely inspect and maintain the areas to eliminate the pollution source.

Waste disposal bins will be inspected daily for leaks and overflowing capacity. Empty as weight or volume capacity is reached, or if the container is leaking. Bins may not be filled above maximum fill line for transportation.

Portable toilets will be located a minimum of 10 feet from stormwater inlets and 50 ft from state waters. They will be secured at all four corners to prevent overturning and cleaned on a weekly basis. They will be inspected daily for spills.

Other Areas or Procedures Where Potential Spills Can Occur

Other areas or procedures where potential spills can occur are not a potential pollution source for the Site.

Training

All contractor's employees and subcontractor's employees shall receive orientation training in "Spill Prevention and Response Procedures". Training will cover responsibilities and procedures to be followed in the event of an on-site material spill. Periodic training shall be conducted during weekly or monthly safety meetings. All training records shall be maintained in the construction trailer. The QSM is responsible for preparing and training site personnel for procedures on potential spills.

XVII. Final Stabilization and Long-Term Stormwater Management

Upon the completion of construction, open space areas of the development will have permanent vegetation installed in conformance with the approved landscaped plan. Final stabilization is reached when all soil-disturbing activities at the Site have been completed, and uniform vegetative cover has been established with a density of at least seventy percent of pre-disturbance levels or equivalent permanent, physical erosion reduction methods have been employed.

XVIII. Inspection and Maintenance

Inspections will be conducted at least every 14 days. At a minimum, the contractor or his agent shall produce and retain weekly written inspection records for all BMP's and within 24 hours of a significant stormwater event or snowmelt event that causes surface erosion. When construction is complete but final stabilization is pending, inspections shall be conducted monthly. All necessary maintenance and repair shall be completed immediately. However, street sweeping is to be completed by the close of the business day or on an as needed basis. It is the responsibility of the contractor to have all erosion control devices in place and effective, prior to a storm event. The QSM must maintain a record of the inspection results for a period of three years following expiration or inactivation of permit coverage.

Record Keeping and Documenting Inspections

The following items (at a minimum) must be documented as part of the Site inspections:

- i. The inspection date;
- ii. Name(s) and title(s) of personnel making the inspection;
- iii. Location(s) of discharges of sediment or other pollutants from the Site;
- iv. Location(s) of BMPs that need to be maintained;
- v. Location(s) of BMPs that failed to operate as designed or proved inadequate for a particular location;
- vi. Location(s) where additional BMPs are needed that were not in place at the time of inspection;
- vii. Deviations from the minimum inspection schedule as provided in Section IX above;

- viii. Description of corrective action for items iii, iv, v, and vi, above, dates corrective action(s) taken, and measures taken to prevent future violations, including requisite changes to the SWMP, as necessary; and
- ix. After adequate corrective action(s) has been taken, or where a report does not identify and incidents requiring corrective action, the report shall contain a signed statement indicating the Site is in compliance with the permit to the best of the signer's knowledge and belief.
- x. Signed site inspection forms must be kept on-site.

XIX. Conclusion

This Stormwater Management Plan is in conformance with the El Paso County's Stormwater Standards Manual and the Colorado Discharge Permit System (CDPS) General Permit COR400000. Additional grading, erosion and sediment control measures may be required of the owner or his/her agents, due to unforeseen erosion problems or if the submitted plan does not function as intended. The requirements of this plan shall be the obligation of the land owner and/or his successors or heirs; until such time as the plan is properly completed, modified, or voided.

This SWMP should be viewed as a "living document" that is continuously reviewed and modified as necessary as part of the overall process of evaluating and managing stormwater quality issues at the site. The QSM shall amend the SWMP when there is a change in design, construction, operations and/or maintenance of the site which would require the implementation of new or revised BMPs, the SWMP provides to be ineffective in achieving the general objectives of controlling pollutants in stormwater discharge associated with construction activity, or when the BMPs are no longer necessary and are removed.

XX. References

1. El Paso County Drainage Criteria Manual; Public Works Department, Engineering Division, Environmental Services Division; December 2019.

2. Colorado Discharge Permit System (CDPS) General Permit COR400000; Colorado Department of Public Health and Environment; Revised January, 2021.
3. National Flood Hazard Layer FIRMette, El Paso County, Colorado, Map No. 08041C0754G, December 7, 2018, Federal Emergency Management Agency.
4. Custom Soil Resource Report, El Paso County Area, Colorado, April 5, 2021, Natural Resources Conservation Service.
5. Geotechnical Investigation, Crossroads Apartments. Colorado Springs, Colorado, CTL Thompson Inc., May, 18, 2021.

APPENDIX A – Vicinity Map, FIRM Map

Plotted: MON 04/05/21 3:02:34P. By: Adam Harkness Filepath: k:\200823\engineering\exhibit\vicinity map.dwg Layout: layout1

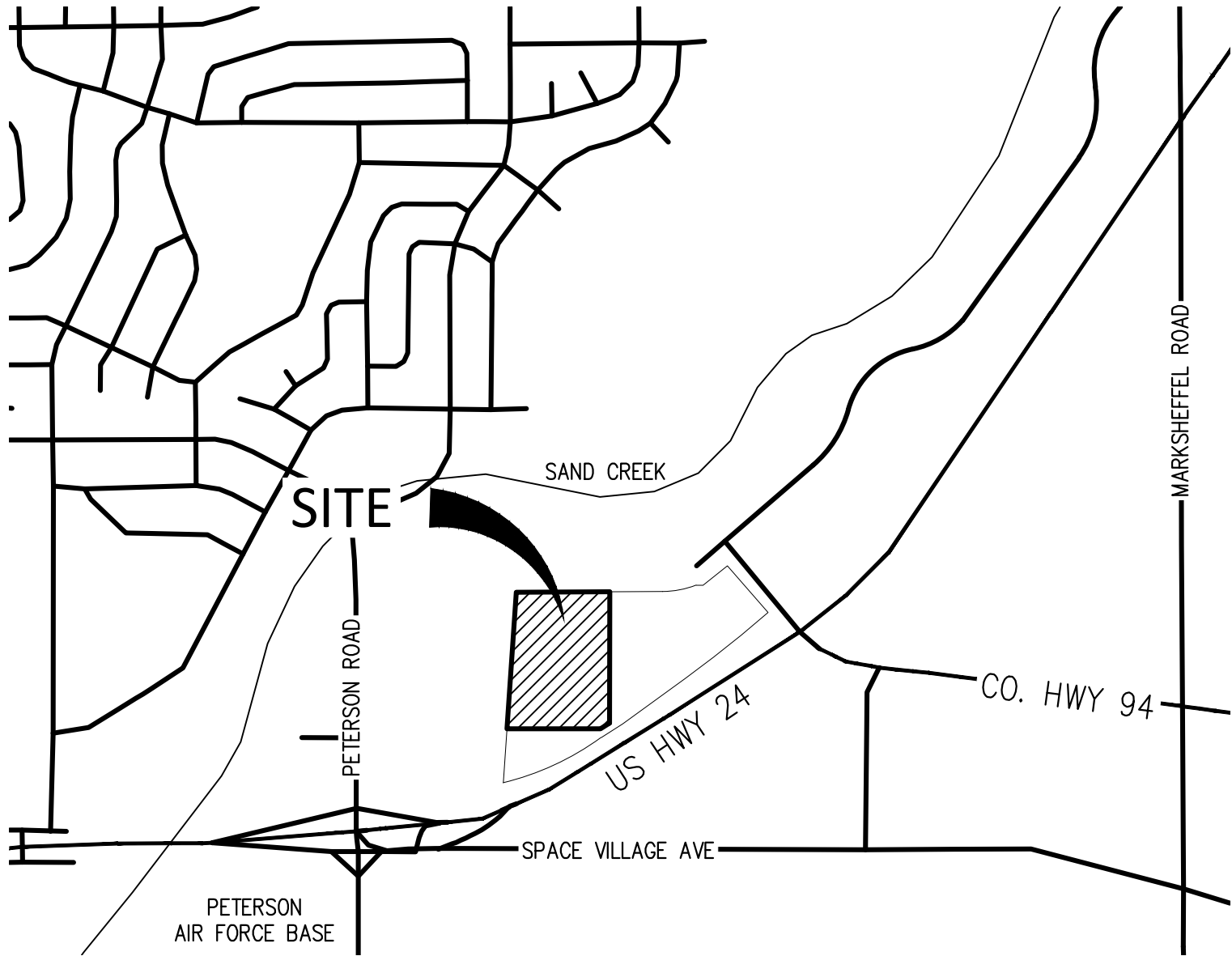

1120 Lincoln Street, Suite 1000
Denver, Colorado 80203
P: 303.623.6300 F: 303.623.6311
HarrisKocherSmith.com

VICINITY MAP

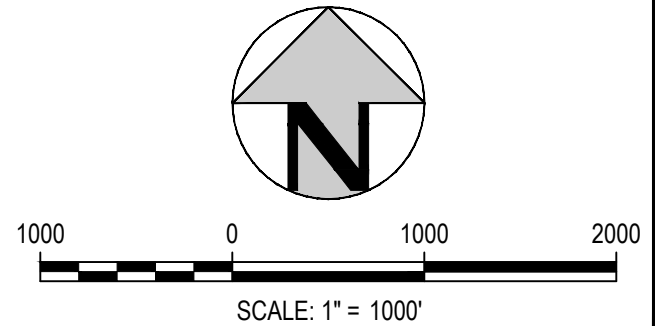

National Flood Hazard Layer FIRMMette



104°42'5"W 38°50'47"N



Legend

SEE FIS REPORT FOR DETAILED LEGEND AND INDEX MAP FOR FIRM PANEL LAYOUT

SPECIAL FLOOD HAZARD AREAS	Without Base Flood Elevation (BFE) Zone A, V, A99	With BFE or Depth Zone AE, AO, AH, VE, AR	Regulatory Floodway

OTHER AREAS OF FLOOD HAZARD	0.2% Annual Chance Flood Hazard, Areas of 1% annual chance flood with average depth less than one foot or with drainage areas of less than one square mile Zone X	Future Conditions 1% Annual Chance Flood Hazard Zone X	Area with Reduced Flood Risk due to Levee. See Notes. Zone X	Area with Flood Risk due to Levee Zone D

OTHER AREAS	NO SCREEN Area of Minimal Flood Hazard Zone X	Effective LOMRs	Area of Undetermined Flood Hazard Zone D

GENERAL STRUCTURES	Channel, Culvert, or Storm Sewer	Levee, Dike, or Floodwall

OTHER FEATURES	Cross Sections with 1% Annual Chance Water Surface Elevation	Coastal Transect	Base Flood Elevation Line (BFE)	Limit of Study	Jurisdiction Boundary	Coastal Transect Baseline	Profile Baseline	Hydrographic Feature

MAP PANELS	Digital Data Available	No Digital Data Available	Unmapped

The pin displayed on the map is an approximate point selected by the user and does not represent an authoritative property location.

This map complies with FEMA's standards for the use of digital flood maps if it is not void as described below. The basemap shown complies with FEMA's basemap accuracy standards

The flood hazard information is derived directly from the authoritative NFHL web services provided by FEMA. This map was exported on 4/6/2021 at 12:22 PM and does not reflect changes or amendments subsequent to this date and time. The NFHL and effective information may change or become superseded by new data over time.

This map image is void if the one or more of the following map elements do not appear: basemap imagery, flood zone labels, legend, scale bar, map creation date, community identifiers, FIRM panel number, and FIRM effective date. Map images for unmapped and unmodernized areas cannot be used for regulatory purposes.

APPENDIX B – Geotechnical Report & Soils Information

**GEOTECHNICAL INVESTIGATION
CROSSROADS APARTMENTS
MEADOWBROOK PARKWAY AND US HIGHWAY 24
COLORADO SPRINGS, COLORADO**

Prepared for:

TRINSIC RESIDENTIAL GROUP
1801 Wewatta Street, Floor 11
Denver, Colorado 80202

Attention: Allison Jones

CTL|T Project No. CS19308-125

May 18, 2021

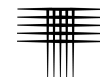
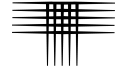

TABLE OF CONTENTS

SCOPE	1
SUMMARY	1
SITE CONDITIONS	2
PROPOSED DEVELOPMENT	3
PREVIOUS INVESTIGATION	3
SUBSURFACE INVESTIGATION	3
SUBSURFACE CONDITIONS	3
Sand Soils.....	4
Bedrock.....	4
Groundwater	4
Seismicity.....	4
SITE DEVELOPMENT	5
Collapse Prone Soils.....	5
Sub-Excavation.....	6
Excavation	7
Fill Placement	7
FOUNDATIONS.....	8
Post-Tensioned, Slabs-On-Grade (PTS).....	9
Spread Footing Foundations.....	10
FLOOR SYSTEMS AND SLABS-ON-GRADE.....	10
Exterior Flatwork	12
SWIMMING POOL AND POOL DECK.....	12
PAVEMENTS.....	14
CONCRETE.....	15
LIMITATIONS	15
REFERENCES	
FIG. 1 – LOCATION OF EXPLORATORY BORINGS	
FIG. 2 – RECOMMENDED SUB-EXCAVATION DEPTHS	
FIG. 3 – RECOMMENDED POOL DRAIN DETAIL	
APPENDIX A – SUMMARY LOGS OF EXPLORATORY BORINGS	
APPENDIX B – LABORATORY TEST RESULTS	
TABLE B-1: SUMMARY OF LABORATORY TESTING	



SCOPE

This report presents the results of our Geotechnical Investigation for the Crossroads Apartments to be located west of the intersection of Highway 24 and Highway 94 in Colorado Springs, Colorado. The investigated parcel is planned for development of multi-family, apartment buildings. The purpose of our investigation was to evaluate the subsurface conditions at the site and provide geotechnical recommendations and criteria for design and construction of foundations, floor systems, and pavement section alternatives, as well as surface drainage precautions. The scope of our services is described in our proposal (CS-20-0127) dated February 10, 2010.

The report was prepared based on conditions interpreted from field reconnaissance of the site, review of previous information, conditions found in our exploratory borings, results of laboratory tests, engineering analysis, and our experience. Observations made during grading or construction may indicate conditions that require revision or re-evaluation of some of the criteria presented in this report. The criteria presented are for the development as described. Revision in the scope of the project could influence our recommendations. If changes occur, we should review the development plans and the effect of the changes on our preliminary design criteria. Evaluation of the property for the possible presence of potentially hazardous materials (Environmental Site Assessment) was beyond the scope of this investigation.

The following section summarizes the report. A more complete description of the conditions found at the site, our interpretations, and our recommendations are included in the report.

SUMMARY

1. The near-surface soils encountered in the twenty-two (22) borings drilled during this investigation consisted of 20 to 30 feet of sand and silty sand soils.
2. At the time of drilling, groundwater was not encountered. Groundwater levels will vary with seasonal precipitation and landscaping irrigation.

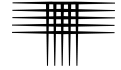

3. We understand both post-tensioned slabs-on-grade (PTS) and spread footing foundations are being considered. Foundation design and construction criteria are presented in the report.
4. If spread footings are used for the apartment buildings, the potential for differential movement between the spread footings and slabs-on-grade would need to be accommodated during design. Post-tensioned slab foundations are structurally integrated and should exhibit more reliable, long-term performance than conventional slabs-on-grade and isolated shallow foundations.
5. Full-depth asphalt concrete and composite asphalt and aggregate base course pavement section alternatives are presented in the report for the planned parking lots and access driveways.
6. Surface drainage should be designed, constructed, and maintained to provide rapid removal of runoff away from the proposed buildings. Conservative irrigation practices should be followed to avoid excessive wetting.
7. The design and construction criteria for foundations and slabs-on-grade included in this report were compiled with the expectation that all recommendations will be incorporated into the project and that the property manager will maintain the structures, use prudent irrigation practices, and maintain surface drainage. It is critical that all recommendations in this report are followed.

SITE CONDITIONS

The investigated parcel of land is situated west of the intersection of Highway 24 and Highway 94 in Colorado Springs, Colorado. The overall ground surface gently slopes downward to the south. Vegetation on the site consists of a slight to moderate stand of mostly grasses and weeds and scattered trees. The parcel is crisscrossed by several narrow, dirt paths. The surficial soils on the site were very loose in areas, generally on the southern side of the lot, and may cause issues with vehicles traversing the site. We had difficulties accessing these areas with the drill rig.

To the south of the site is Highway 24, to the north is a residential development. An abandoned sports complex that once had baseball diamonds is to the west. The parcel directly to the east is vacant.

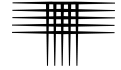

PROPOSED DEVELOPMENT

We understand the proposed development will include an apartment complex consisting of eight apartment buildings, a clubhouse, and a pool. The apartments are anticipated to be two to three-story, wood-frame structures. Foundation loads are expected to be light to moderate. No habitable, below-grade construction is expected. The complex will include paved access roads and automobile parking stalls.

PREVIOUS INVESTIGATION

We previously reviewed the Soils and Geology Study performed by RMG Engineers, CTL|T Project No. CS19308-115, report dated November 13, 2020. This report was reviewed as part of this investigation.

SUBSURFACE INVESTIGATION

Subsurface conditions at the site were investigated by drilling twenty-two borings at the locations shown in Fig. 1. Graphical logs of the conditions found in our exploratory borings, the results of field penetration resistance tests, and some laboratory data are presented in Appendix A. Swell-consolidation and gradation test results are presented in Appendix B. Laboratory test data are summarized in Table B-1. Summary logs from our previous investigation are shown in Appendix D.

Soil samples obtained during this study were returned to our laboratory and visually classified. Laboratory testing was then assigned to representative samples. Testing included moisture content and dry density, gradation analysis, Atterberg limits, and water-soluble sulfate content tests.

SUBSURFACE CONDITIONS

The soils encountered in the twenty-two borings drilled during this investigation consisted of 20 to 30-feet of sand and silty sand soils. Sandstone bedrock was encountered in one boring at a depth of 29-feet. Some of the pertinent engineering characteris-

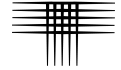

tics of the soils and bedrock encountered and groundwater conditions are discussed in the following paragraphs.

Sand Soils

The soils encountered consisted of clean to silty sand. The sand encountered in the borings extended to the maximum depth explored of 30-feet below the existing ground surface. The sand was loose to very dense based on the results of field penetration resistance tests. Samples of the sand tested in our laboratory contained 5 to 35 percent clay and silt-sized particles (passing the No. 200 sieve). Our experience indicates the clean to silty sands are non-expansive when wetted.

Sand fill was logged in one boring (TH-2) to a depth of 7-feet below the existing ground surface. The material was identified as fill based on the color variation of the sample, however the lab testing indicates that the material properties are consistent with the native sand soil.

Bedrock

Sandstone bedrock was encountered in one boring (TH-10) at a depth of 29 feet. The sandstone was very hard based on the results of field penetration resistance tests. Our experience indicates the bedrock is non-expansive when wetted.

Groundwater

At the time of drilling, groundwater was not encountered. Due to the nature of the onsite materials, we were not able to check water levels several days after the completion of drilling operations as the boring holes had collapsed. Groundwater levels will vary with seasonal precipitation and landscaping irrigation.

Seismicity

This area, like most of central Colorado, is subject to a degree of seismic activity. Geologic evidence has been interpreted to indicate that movement along some Front

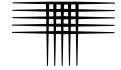

Range faults has occurred during the last two million years (Quaternary). This includes the Rampart Range Fault, which is located several miles west of the site. We believe the soils on the property classify as Site Class D (stiff soil profile) according to the 2015 International Building Code (2015 IBC).

SITE DEVELOPMENT

We do not expect significant issues due to geotechnical considerations to impact the development of the site. The most significant geotechnical constraint identified is the presence of collapse-prone soils. The following sections provide considerations and recommendations as they relate to site development

Grading plans prepared by Civil Consultants, Inc. dated February 16, 2021 were provided. The plans suggest cuts up to about 6-feet and fills up to about 8-feet will be necessary to achieve the desired building pad elevations. We believe site grading can be accomplished using conventional, heavy-duty earthmoving equipment. We recommend grading plans consider long-term cut and fill slopes no steeper than 3:1 (horizontal to vertical). This ratio considers that no seepage of groundwater occurs. If groundwater seepage does occur, a drain system and flatter slopes may be appropriate.

Collapse-Prone Soils

Collapse-prone soils are present at this site. Collapse-prone soils may be susceptible to hydro-collapse, a phenomenon where soils undergo a decrease in volume upon an increase in moisture content, with or without an increase in external loads. The presence of collapse-prone soils implies risk that slabs-on-grade and foundations will settle and be damaged. The risks associated with collapse-prone soils can be mitigated by careful design, construction, and maintenance procedures. We believe the recommendations in this report will help to control risk of foundation and/or slab damage; they will not eliminate that risk. The owner should understand that slabs-on-grade and, in some instances, foundations may be affected by these soils. Maintenance will be required to control risk. We believe the collapse-prone soils at this site present a moder-

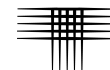

ate to low risk without mitigation, with the risk being lower on the northern side of the property and increasing to the south.

In general, the soils identified as collapse-prone are on the southern half of the site. The RMG report discussed in the Previous Investigation section, indicated that the northern half of this parcel has a circular, bulbous feature that they mapped as an area that has been “disturbed from past activity on the site and/or from historical overflow of sediment and water from EFSC from the north.” Our testing indicates the soils in this area more consolidated.

Sub-Excavation

Sub-excavation will reduce the risk of excessive differential movement and create a more uniform bearing layer for support of the proposed structures. The northern buildings and the swimming pool should be constructed on at least a 2-foot-thick layer of new or sub-excavation backfill and the southern buildings should be constructed on at least a 4-foot-thick layer of new or sub-excavation backfill. The thickness of fill should be measured from the lowest member of the foundation system, or the swimming pool subgrade. The recommended depth of sub-excavation for each building is shown in Fig. 2.

The sub-excavation zone should extend laterally at least 5 feet beyond the outer edges of the structures and should have a uniform bottom elevation throughout the structure footprint. After the existing material is removed, the on-site existing fill materials, or imported granular fill can be used as excavation backfill. The sub-excavation zone should be backfilled to the bottom of foundation elevations with densely compacted fill that has been properly moisture conditioned and compacted as described in the Fill Placement section.

Our representative should observe the completed excavation prior to any backfill placement to verify the conditions exposed in the excavation are as expected. The placement and compaction of fill below foundations and foundation subgrade preparation should be observed and tested by a representative of our firm during construction.

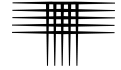

Excavation

We believe the soils encountered in our exploratory borings can be excavated with conventional, heavy-duty excavation equipment. We recommend the contractor become familiar with applicable local, state, and federal safety regulations, including the current Occupational Safety and Health Administration (OSHA) Excavation and Trench Safety Standards, to determine appropriate excavation slopes. We anticipate the grading fill (existing and new) and the near-surface, natural soils will classify as Type C materials. Temporary excavations in Type C soils require a maximum slope inclination of 1.5:1 (horizontal to vertical), unless the excavation is shored or braced. If groundwater seepage occurs, flatter slopes will likely be required. The contractor's "competent person" should review excavation conditions and refer to OSHA standards when worker exposure is anticipated. Stockpiles and equipment should not be placed within a horizontal distance equal to one-half the excavation depth, from the edge of the excavation. Excavations deeper than 20 feet should be designed by a registered professional engineer.

Fill Placement

The properties of the fill will affect the performance of foundations, slabs-on-grade, and pavements. The on-site soils, when free of debris, can be used as site grading fill. We anticipate most of the grading fill will consist of silty sand soils that are generated from cuts into the near surface. If import materials will be used, the import should preferably consist of granular soils, similar to the on-site soils. Import fill materials should exhibit liquid limits of less than 30 and plasticity indices of less than 10. A sample of the import fill should be submitted to our office for testing before transporting to the site.

Vegetation, topsoil, and organic materials should be removed from the ground surface where fill will be placed at the site. Soft or loose soils, if encountered, should be stabilized or removed to stable material prior to placement of grading fill. Organic soils should be wasted in landscaped areas. The ground surface in areas to receive fill



should be scarified, moisture conditioned to near optimum moisture contents, and compacted to a high density to provide a firm base.

We recommend the fill be placed at relatively uniform moisture contents within 2 percent of optimum moisture content and compacted in thin lifts to at least 95 percent of maximum modified Proctor dry density (ASTM D 1557) for granular materials. Placement and compaction of the grading fill should be observed and tested by our representative during construction.

Water and sewer lines are often constructed beneath slabs and pavements. Compaction of utility trench backfill can have a significant effect on the life and serviceability of floor slabs, pavements, and exterior flatwork. We recommend utility trench backfill be placed in compliance with City of Colorado Springs specifications. Personnel from our firm should periodically observe utility trench backfill placement and test the density of the backfill materials during construction.

FOUNDATIONS

Based on the conditions encountered in our exploratory borings and the planned site grading cuts and fills, we anticipate the near-surface soils found at or near shallow foundation levels for the proposed apartment buildings and clubhouse will consist predominantly of clean to silty sand and new, sand grading fill. These granular materials are non-expansive when wetted.

Based on the results of our borings, laboratory testing, and understanding of the planned construction, we believe the proposed apartment buildings can be constructed with shallow foundations consisting of post-tensioned, slab-on-grade (PTS) foundations or spread footing foundations. If spread footings are used for the apartment buildings, the potential for differential movement for this type of building, between the spread footings and slabs-on-grade would need to be accommodated during design. Post-tensioned slab foundations are structurally integrated and should exhibit more reliable, long-term performance than conventional slabs-on-grade and isolated shallow founda-

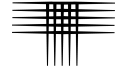

tions. Criteria for post-tensioned, slabs-on-grade are presented in the Post-Tensioned, Slabs-on-Grade section. Criteria for spread footings are presented in the Spread Footings section. We are available to discuss foundation alternatives, as desired.

Post-Tensioned, Slabs-On-Grade (PTS)

We understand post-tensioned, slab-on-ground (PTS) foundations are being considered for the proposed apartment buildings and the clubhouse. In our opinion, the on-site soils are suitable for construction of the planned PTS foundations. Conditions encountered in our borings suggest that the complex can be considered a “Non-Active Site” as defined in Section 3.2.3 of the “Design of Post-Tensioned Slabs-on-Ground” manual developed by the Post-Tensioning Institute (PTI, 3rd Edition, 2004). The design of a PTS foundation for a non-active site requires that the foundation need only be checked for bearing and lightly reinforced against shrinkage and temperature cracking.

1. PTS foundations should be constructed on newly placed fill, and/or reprocessed fill, as described previously.
2. The PTS foundations should be designed for a maximum allowable soil pressure of 2,000 psf.
3. Perimeter stiffening beams may be poured “neat” into trenches excavated in the building pads. The on-site sands may cave or slough during trench excavation for the stiffening beams. Disturbed soils should be removed from trench bottoms prior to placement of concrete. Formwork or other methods may be required for proper beam installation.
4. For slab tensioning design, a coefficient of friction value of 0.75 or 1.0 can be used for slab construction on polyethylene sheeting or a sand layer, respectively. A coefficient of friction of 2 should be used for slabs on fill or native soil.
5. Exterior stiffening beams must be protected from frost action. Normally, 30 inches of frost cover is provided in this area.
6. A representative of our firm should observe the completed excavations. We should also observe the placement of the reinforcing tendons and reinforcement prior to placing the slabs and beams, as well as observe the tensioning of the tendons.

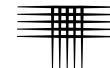

Spread Footing Foundations

1. We recommend the spread footing foundations be constructed on newly placed fill, and/or reprocessed fill, as described previously.
2. Spread footings can be designed for a maximum allowable soil pressure of 2,000 psf.
3. Spread footings beneath continuous foundation walls should be at least 16 inches wide. Footings beneath isolated column pads should be at least 24 inches square. Larger footing sizes could be required to accommodate the anticipated foundation loads.
4. We recommend designs consider total settlement of 1-inch and differential settlement of 1/2-inch.
5. Continuous foundation stem walls should be reinforced, top and bottom, to span local anomalies in the subsoils. We recommend the reinforcement required to simply span an unsupported distance of at least 10 feet.
6. Exterior spread footings within the garages must be protected from frost action. Typically, at least 30 inches of soil cover is provided in this area.
7. A representative of our firm should observe the completed foundation excavations to confirm the exposed conditions are similar to those encountered in our exploratory borings. The placement and compaction of below-foundation fill and foundation subgrade preparation should be observed and tested by a representative of our firm during construction.

FLOOR SYSTEMS AND SLABS-ON-GRADE

As previously discussed, soils below the foundations will consist of a layer of granular fill over the existing granular soils. Considering a 15-foot depth of wetting, our calculations indicate potential ground settlement within the building footprint of less than 1 inch to about 2 inches. Granular material settles more quickly than clay and clayey materials, and some of the internal settlement may occur during construction.

For the PTS system, the foundation is structurally integrated with the floor slab and should exhibit more reliable long-term performance, as compared to conventional slab-on-grade floors. Under-slab utilities such as water and sewer lines should be pressure tested prior to installing slabs. Utilities that penetrate slabs should be provided with sleeves and flexible connections that allow for independent movement of the slab and that reduce the likelihood of damaging buried pipes. We recommend these details allow at least 2 inches of differential movement between the slabs and pipes.

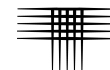

For the post-tensioned slabs-on-grade system, the foundation is structurally integrated with the floor slab and should exhibit more reliable long-term performance, as compared to conventional slab-on-grade floors. Where slab-on-grade construction is used, we recommend the following precautions.

Fill placed below the slabs should be constructed per the Fill Placement section of this report. Building foundations underlain by granular soils will settle relative to more lightly loaded slab-on-grade floors. The settlement can cause cosmetic cracking of drywall. We recommend slab-on-grade floors be separated from exterior walls and interior bearing members with joints that allow for independent vertical movements of the slab relative to the foundation. Provision of a 1-1/2 inch thick slip joint in slab-bearing partitions can reduce the risk of cracking of drywall resulting from movement of structural elements. If the “float” is provided at the tops of partitions, the connection between interior, slab-supported partitions and exterior, foundation-supported walls should be detailed to allow differential movement. These architectural connections are critical to help reduce cosmetic damage when foundations and floor slabs move relative to each other. We have seen instances where these architectural connections were not designed and constructed properly and resulted in moderate cosmetic damage, even though the movement experienced was well within the anticipated range. The architect should pay special attention to these issues and detail the connections accordingly.

From a geotechnical viewpoint, we believe the floor slabs can be placed directly on the subgrade soils. The 2015 International Building Code (IBC) requires a vapor retarder be placed between base course or subgrade soils and the concrete slab-on-grade floor, unless the designer of the floor (structural engineer) waives this requirement. The merits of installation of a vapor retarder below a floor slab depend on the sensitivity of floor coverings and building use to moisture. A properly installed vapor retarder (10 mil minimum) is more beneficial below concrete slab-on-grade floors where floor coverings, painted floor surfaces or products stored on the floor will be sensitive to moisture. The vapor retarder is most effective when concrete is placed directly on top of it, rather than placing a sand or gravel leveling course between the vapor retarder and the floor slab. The placement of concrete on the vapor retarder may increase the risk of

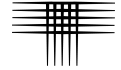

shrinkage cracking and curling. Use of concrete with reduced shrinkage characteristics including minimized water content, maximized coarse aggregate content, and reasonably low slump will reduce the risk of shrinkage cracking and curling. Considerations and recommendations for the installation of vapor retarders below concrete slabs are outlined in Section 3.2.3 of the 2006 report of the American Concrete Institute (ACI) Committee 302, “Guide for Concrete Floor and Slab Construction (ACI 302.R-96)”.

Underslab plumbing should be avoided as much as possible. If underslab plumbing is necessary, service lines should be pressure tested for leaks during construction. Any utility lines that penetrate the slabs should be isolated from the slabs with joints to allow for free vertical movement. Slab-supported mechanical systems should have flexible connections to allow for vertical movement without rupturing supply lines.

Frequent control joints should be provided in the slabs to reduce the effects of curling and help reduce shrinkage cracking. Our experience indicates joint spacing of not greater than 30 times the slab thickness is effective in this area.

Exterior Flatwork

Exterior flatwork is normally constructed as a slab-on-grade. Performance of conventional slabs-on-grade is erratic. Various properties of the soils and environmental conditions influence magnitude of settlement and other performance characteristics. Increases in the moisture content in the underlying soils can result in settlement and possible cracking of slabs-on-grade. Backfill below slabs should be moisture conditioned and compacted to reduce settlement, as discussed in the Fill Placement section. Driveways and exterior slabs founded on backfill may settle and crack if the backfill is not properly moisture treated and compacted.

SWIMMING POOL AND POOL DECK

We understand a swimming pool is planned in association with the proposed clubhouse. No plans were available at the time of this investigation. We anticipate the pool structure may consist of spray-applied gunite against natural soil, or possibly a

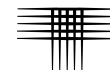

steel or a fiberglass shell. Because of the granular nature of the on-site soils, vertical excavation of the pool walls required for gunite pool construction may not be possible. A fiberglass or steel shell placed in an enlarged excavation may then be the more feasible option. If gunite methods are used, the cement slurry should be properly reinforced.

We recommend the pool be underlain by a drain system that collects water leakage and provides for discharge of the water to a sump or gravity outfall. The drain system should consist of free-draining gravel covering the bottom of the pool excavation. The excavation should slope to a 3 to 4-inch diameter, perforated or slotted pipe placed within the gravel layer. The drain should lead to a positive gravity outlet, such as a sub-drain located beneath the sewer, or to a sump where water can be removed by pumping. A conceptual pool drain system is presented in Fig. 3. Overall surface drainage patterns should be planned to provide for the rapid removal of storm runoff and water that splashes over the edges of the pool.

The swimming pool structure may settle more than the flatwork surrounding the pool. To avoid damage to the pool structure, a slip joint should be used around the perimeter of the pool structure and adjacent to any other structural elements. Utility lines that penetrate the pool structure should be separated and isolated with joints to allow for free vertical movement. All ducts with connections between the pool structure and surrounding soil should be flexible or “crushable,” to allow some relative movement.

Pool decking should be constructed directly on the newly moisture conditioned and densely compacted sub-excavation backfill and be isolated from the swimming pool. Movement of the deck should not be transmitted to the swimming pool. The deck slab should be reinforced to function as an independent unit. Frequent control joints should be provided to reduce problems associated with potential soil movements. Panels that are approximately square generally perform better than rectangular areas.

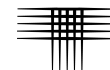

PAVEMENTS

Our exploratory borings and understanding of the proposed construction suggest the subgrade soils within the planned access driveways and parking lots will consist of silty sand and new grading fill. The anticipated subgrade soil sample tested in our laboratory classified as A-1-b to A-2-4 material, according to the American Association of State Highway Transportation Officials (AASHTO) classification system. These group classifications generally exhibit good pavement support characteristics. Based on our laboratory classification testing (Atterberg Limits and sieve analysis) and experience with similar soils in the area a Hveem Stabilometer (“R”) value of 50 was assigned to the subgrade materials for design purposes.

We anticipate the access driveways could be subjected to occasional heavy vehicle loads such as trash trucks and moving vans. We considered daily traffic numbers (DTN) of 2 for the parking stalls and 10 for the access driveways, which correspond to 18-kip Equivalent Single-Axle Loads (ESAL) of 14,600 and 73,000, respectively, for a 20-year pavement design life. We believe the parking stalls can be paved with 4 inches of asphalt concrete or 3 inches of asphalt concrete over 4 inches of aggregate base course. The access driveways and other portions of the proposed paved areas subjected to occasional truck traffic should be paved with 6 inches of asphalt concrete or 4 inches of asphalt underlain by 6 inches of aggregate base course.

We recommend a concrete pad be provided at the trash dumpster sites. The pads should be at least 6 inches thick and long enough to support the entire length of the trash truck and dumpster. The concrete pad should extend at least 5 feet outside of the anticipated truck dimensions. Joints between concrete and asphalt pavements should be sealed with a flexible compound.

Our design considers pavement construction will be completed in accordance with the City of Colorado Springs “Standard Specifications” and the Pikes Peak Region Asphalt Paving Specifications. The specifications contain requirements for the pavement materials (asphalt, base course, and concrete) as well as the construction practic-

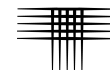

es used (compaction, materials sampling, and proof-rolling). Of particular importance are those recommendations directed toward subgrade and base course compaction and proof-rolling. During proof-rolling, particular attention should be directed toward the areas of confined backfill compaction. Soft or loose subgrade or areas that pump excessively should be stabilized prior to pavement construction. A representative of our office should be present at the site during placement of fill and construction of pavements to perform density testing.

CONCRETE

Concrete in contact with soils can be subject to sulfate attack. We measured the water-soluble sulfate concentration in three samples from the site at less than 0.1 percent. Sulfate concentrations of less than 0.1 percent indicate Class 0 exposure to sulfate attack for concrete in contact with the subsoils, according to ACI 201.2R-01, as published in the 2008 American Concrete Institute (ACI) Manual of Concrete Practice. For this level of sulfate concentration, the ACI indicates Type I cement can be used for concrete in contact with the subsoils. Superficial damage may occur to the exposed surfaces of highly permeable concrete, even though sulfate levels are relatively low. To control this risk and to resist freeze-thaw deterioration, the water-to-cementitious material ratio should not exceed 0.50 for concrete in contact with soils that are likely to stay moist due to surface drainage or high-water tables. Concrete subjected to freeze-thaw cycles should be air entrained.

LIMITATIONS

The recommendations and conclusions presented in this report were prepared based on conditions disclosed by our exploratory borings, geologic reconnaissance, engineering analyses, and our experience. Variations in the subsurface conditions not indicated by the borings are possible and should be expected.

We believe this report was prepared with that level of skill and care ordinarily used by geologists and geotechnical engineers practicing under similar conditions. No warranty, express or implied, is made.



Should you have any questions regarding the contents of this report or the project from a geotechnical engineering point-of-view, please call.

CTL | THOMPSON, INC.



Gwendolyn E. Eberhart, P.E.
Project Engineer

Reviewed by:

Jeffery M. Jones, P.E.
Associate Engineer

GE:JMJ:ge
(3 copies sent)
Via email: ajones@trinsicres.com

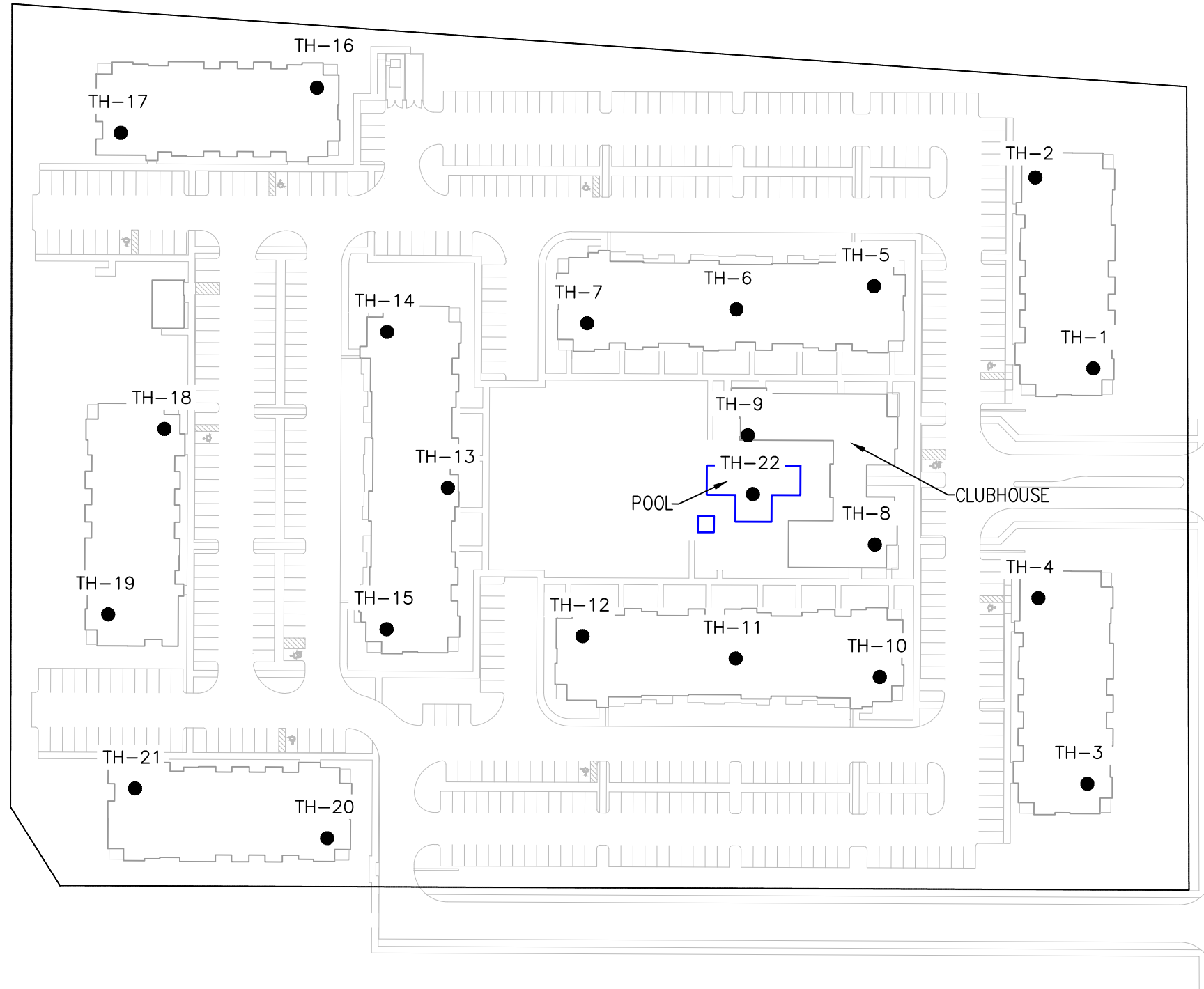
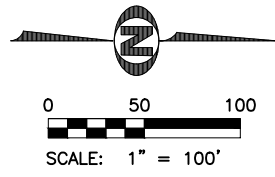

PROPOSED MEADOWBROOK PARKWAY

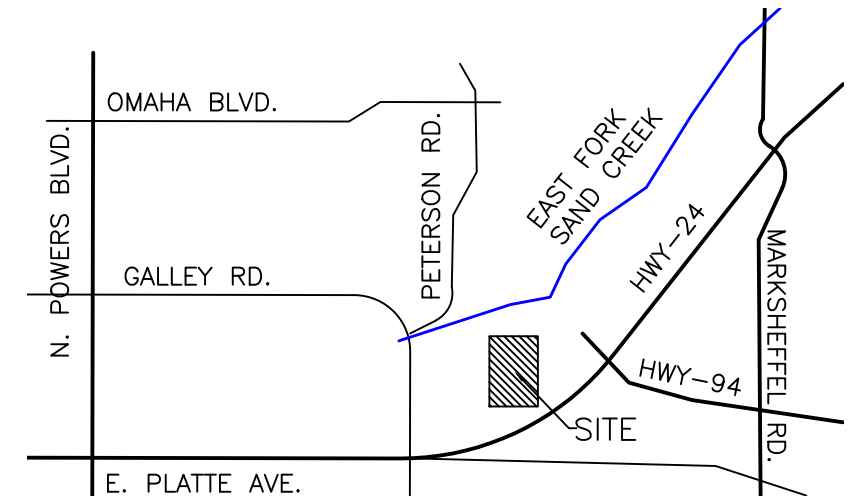

VICINITY MAP
NOT TO SCALE

LEGEND:

- TH-1 APPROXIMATE LOCATION OF EXPLORATORY BORING

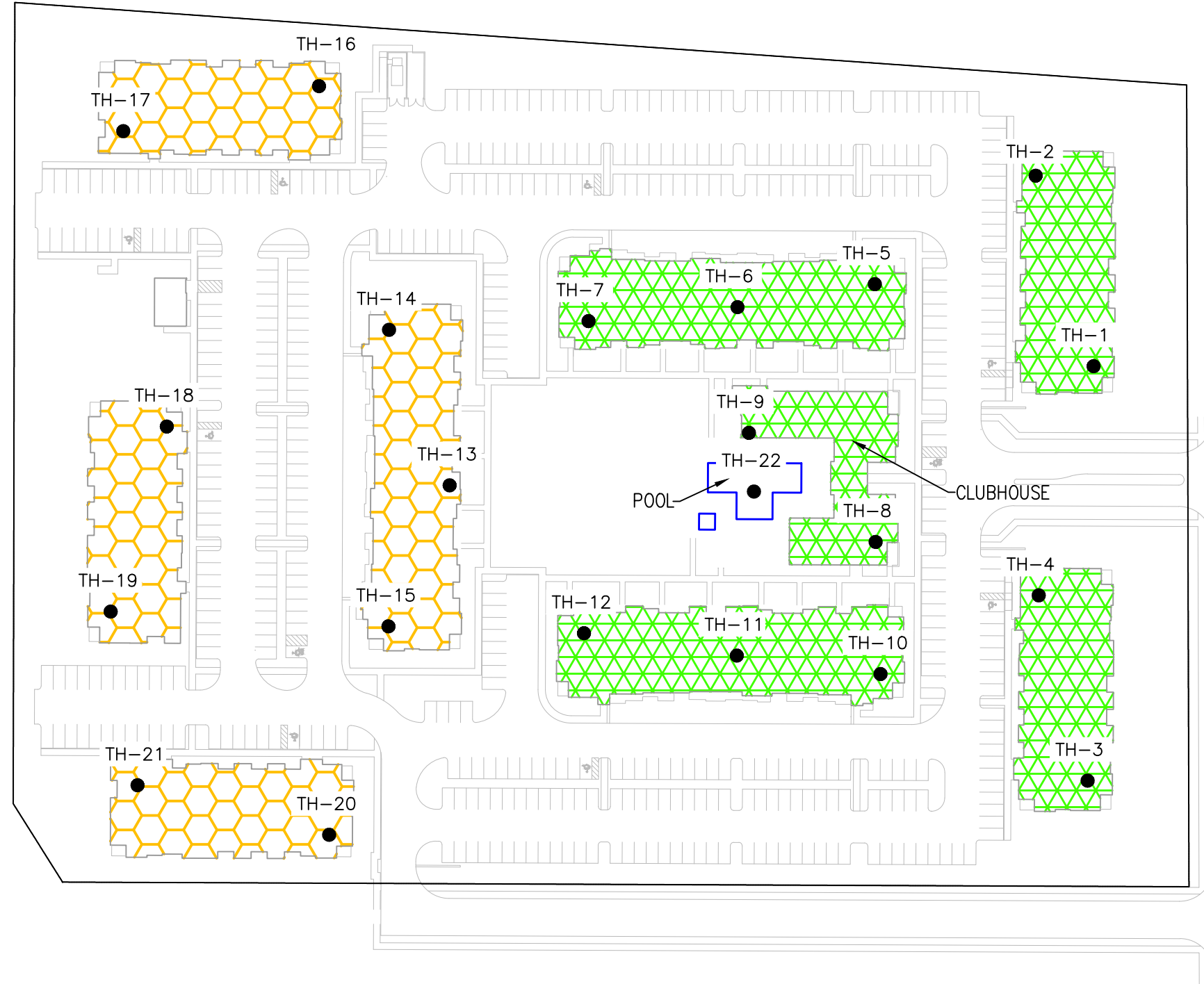
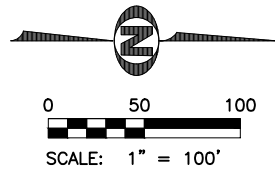

RECOMMENDED SUB-EXCAVATION DEPTHS:

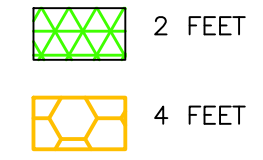

LEGEND:



NOT TO SCALE

POOL DECK

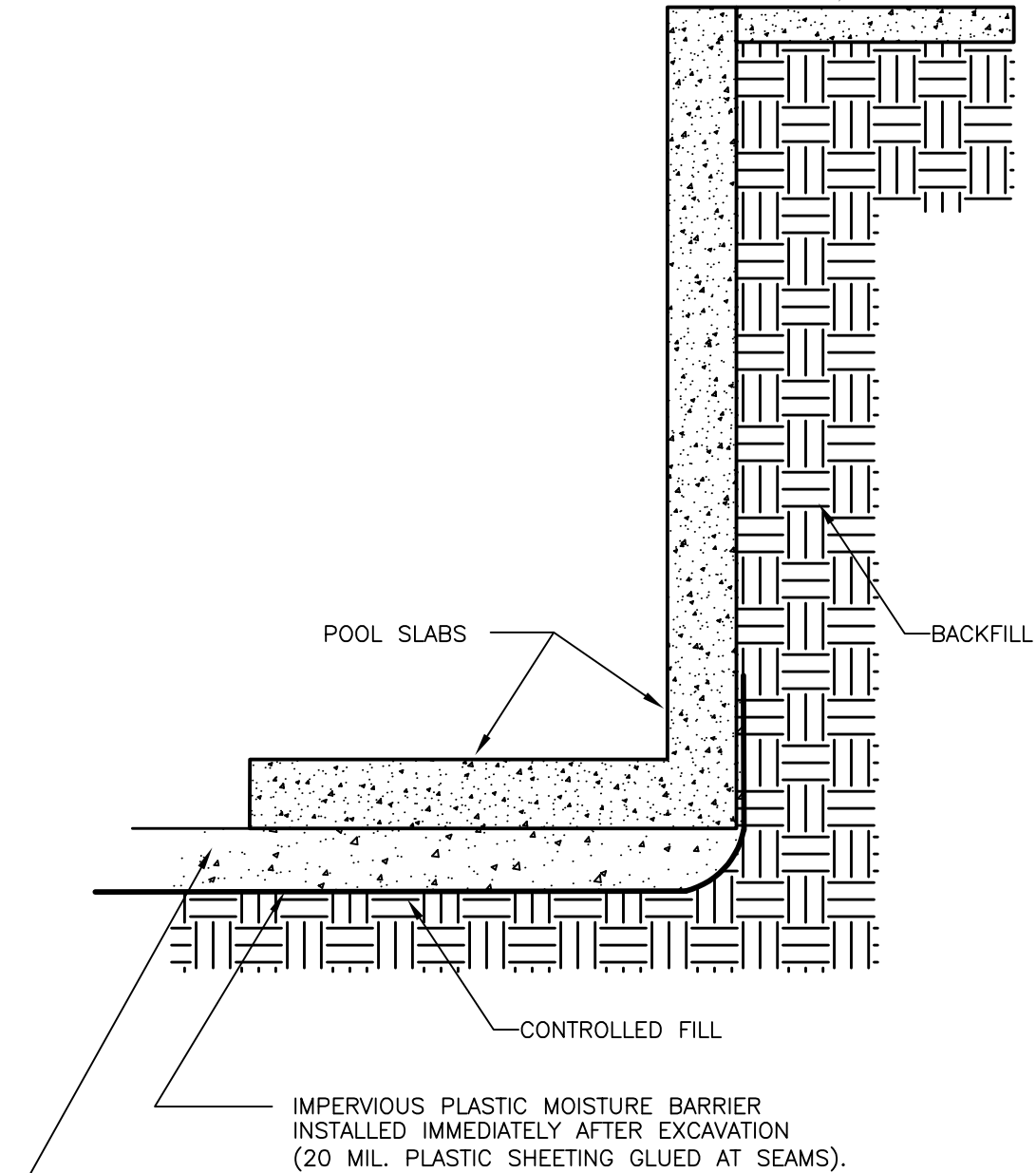

4 TO 6 INCHES OF WASHED 3/4-INCH TO NO. 4 CONCRETE AGGREGATE WITH A MAXIMUM OF 3 PERCENT PASSING NO. 200 SIEVE (SLOPE TO DRAIN)

NOTE:

DRAIN PIPE SHOULD CONSIST OF A 3 OR 4-INCH DRAIN PIPE WITH A MINIMUM SLOPE OF 1/8 INCH DROP PER FOOT, TO A POSITIVE GRAVITY OUTLET OR TO A SUMP WHERE WATER CAN BE REMOVED BY PUMPING.

Recommended Pool Drain Detail

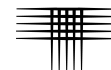

APPENDIX A

SUMMARY LOGS OF EXPLORATORY BORINGS

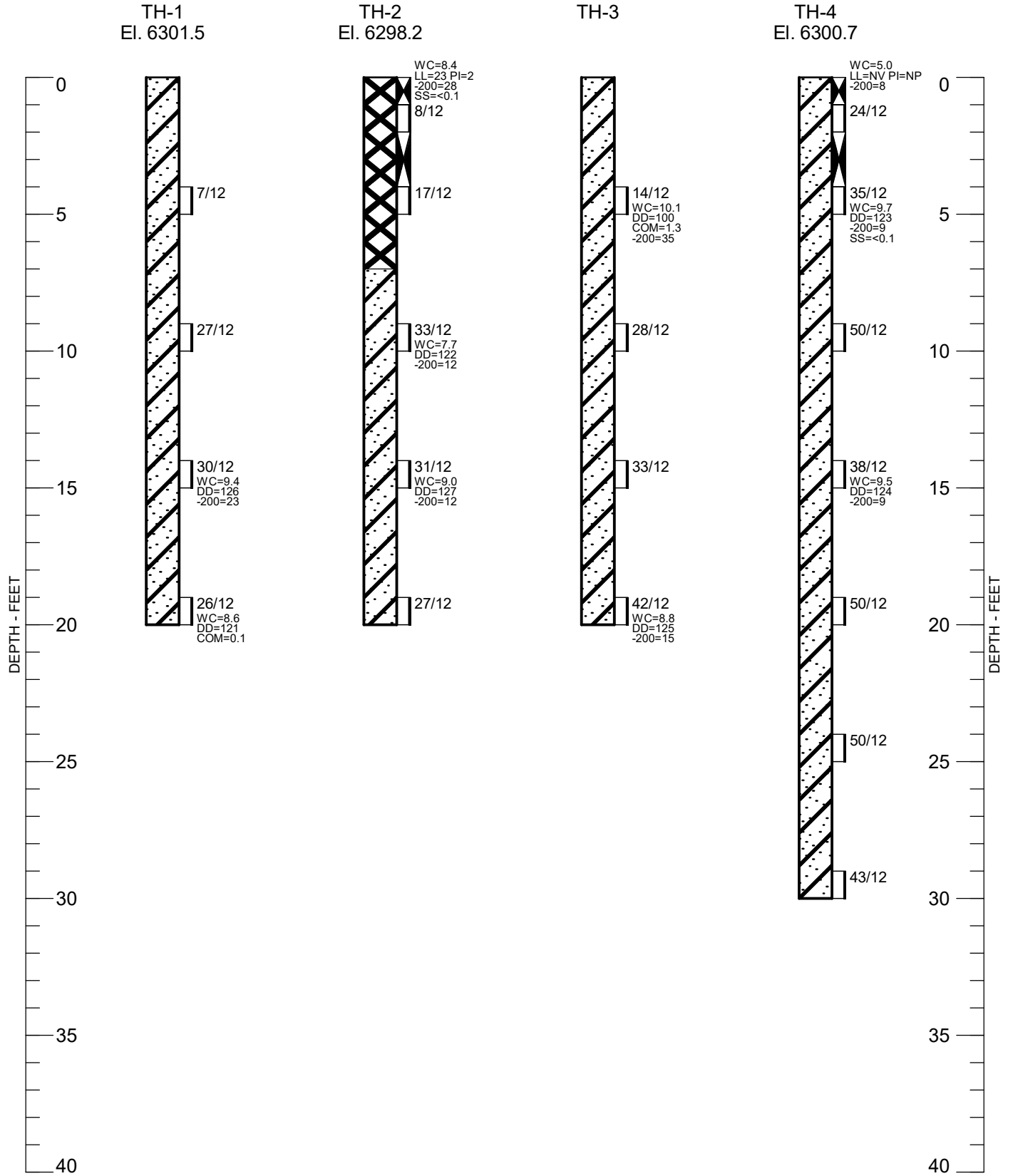

SUMMARY LOGS OF EXPLORATORY BORINGS

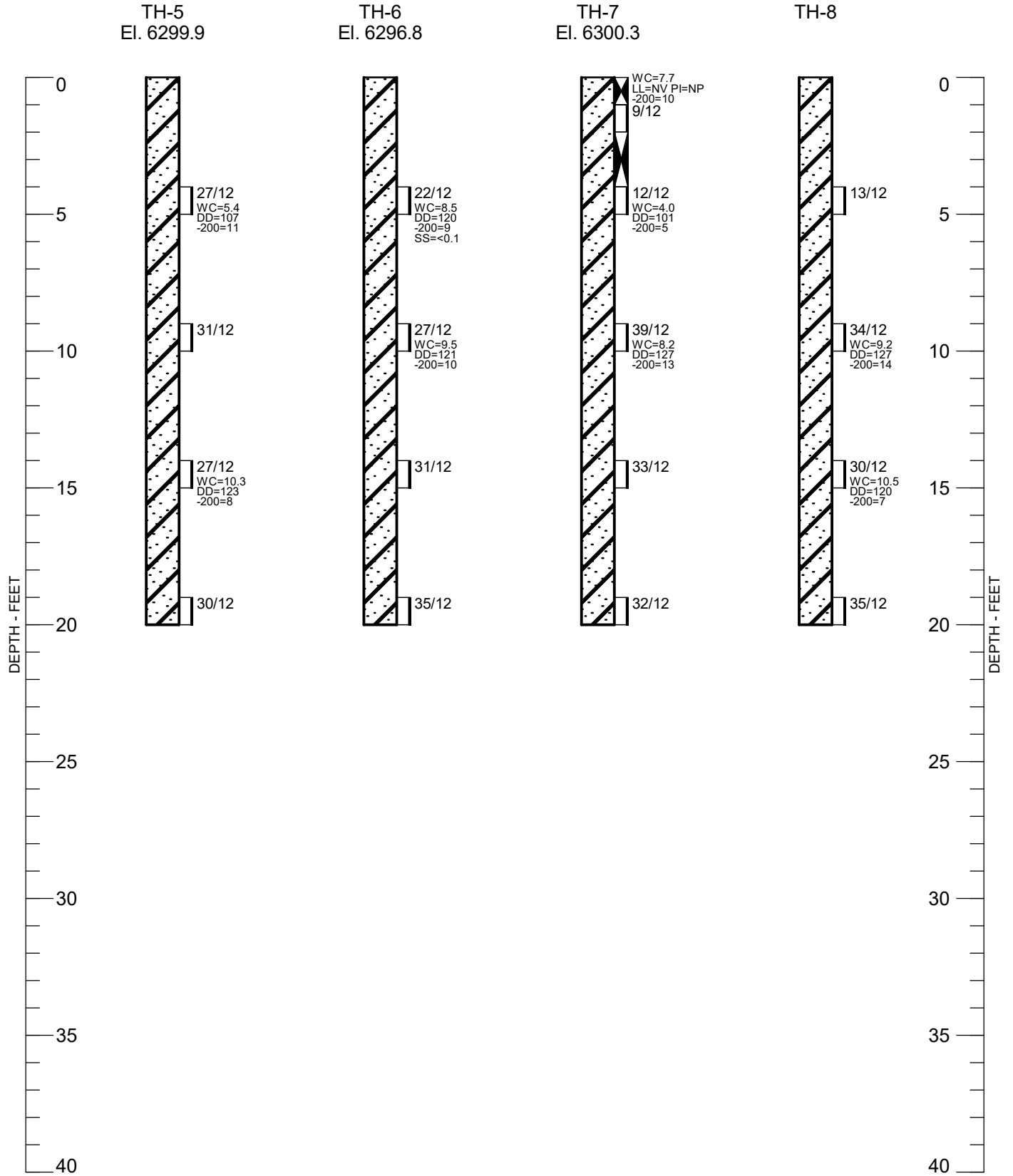

SUMMARY LOGS OF EXPLORATORY BORINGS

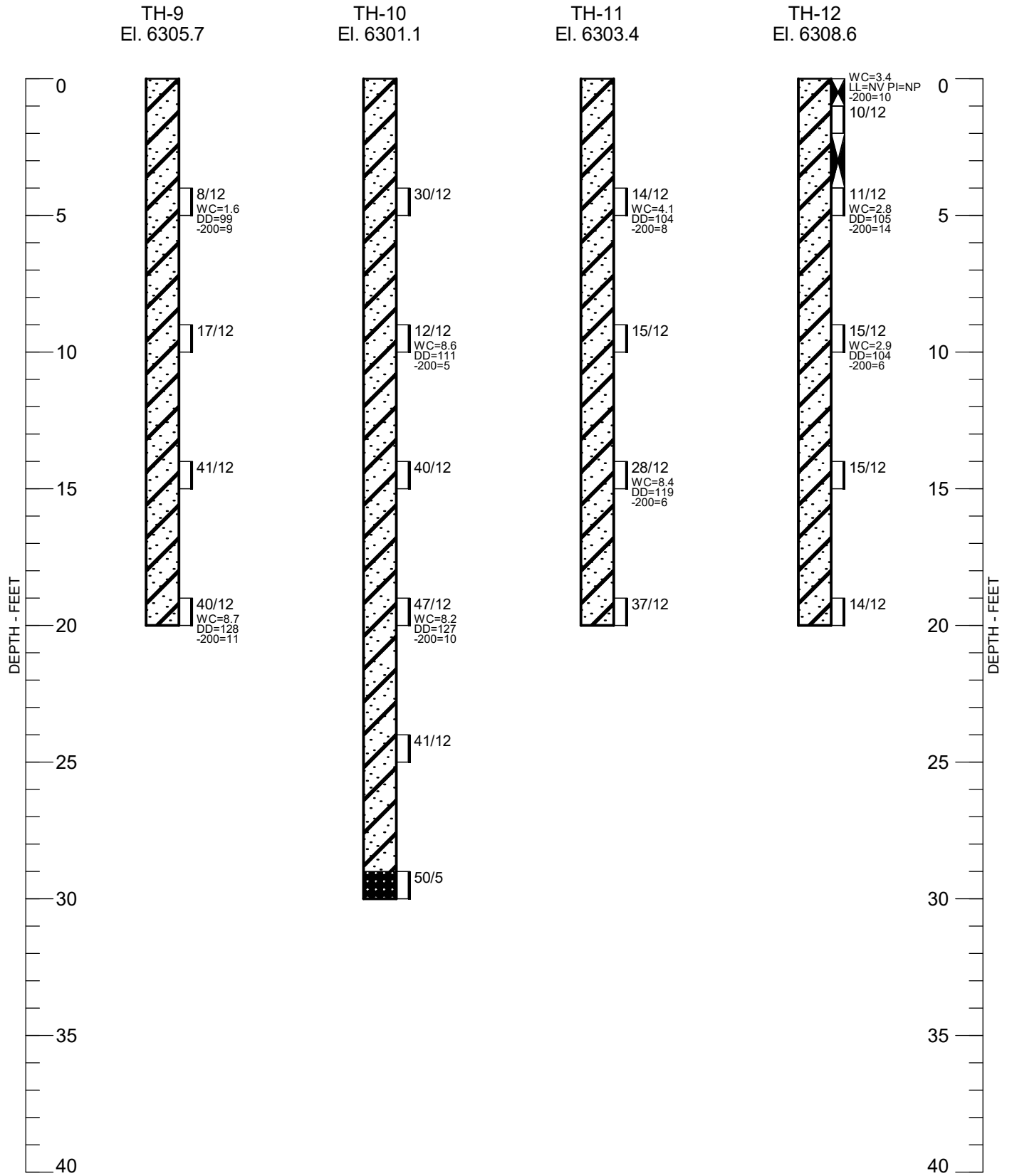

SUMMARY LOGS OF EXPLORATORY BORINGS

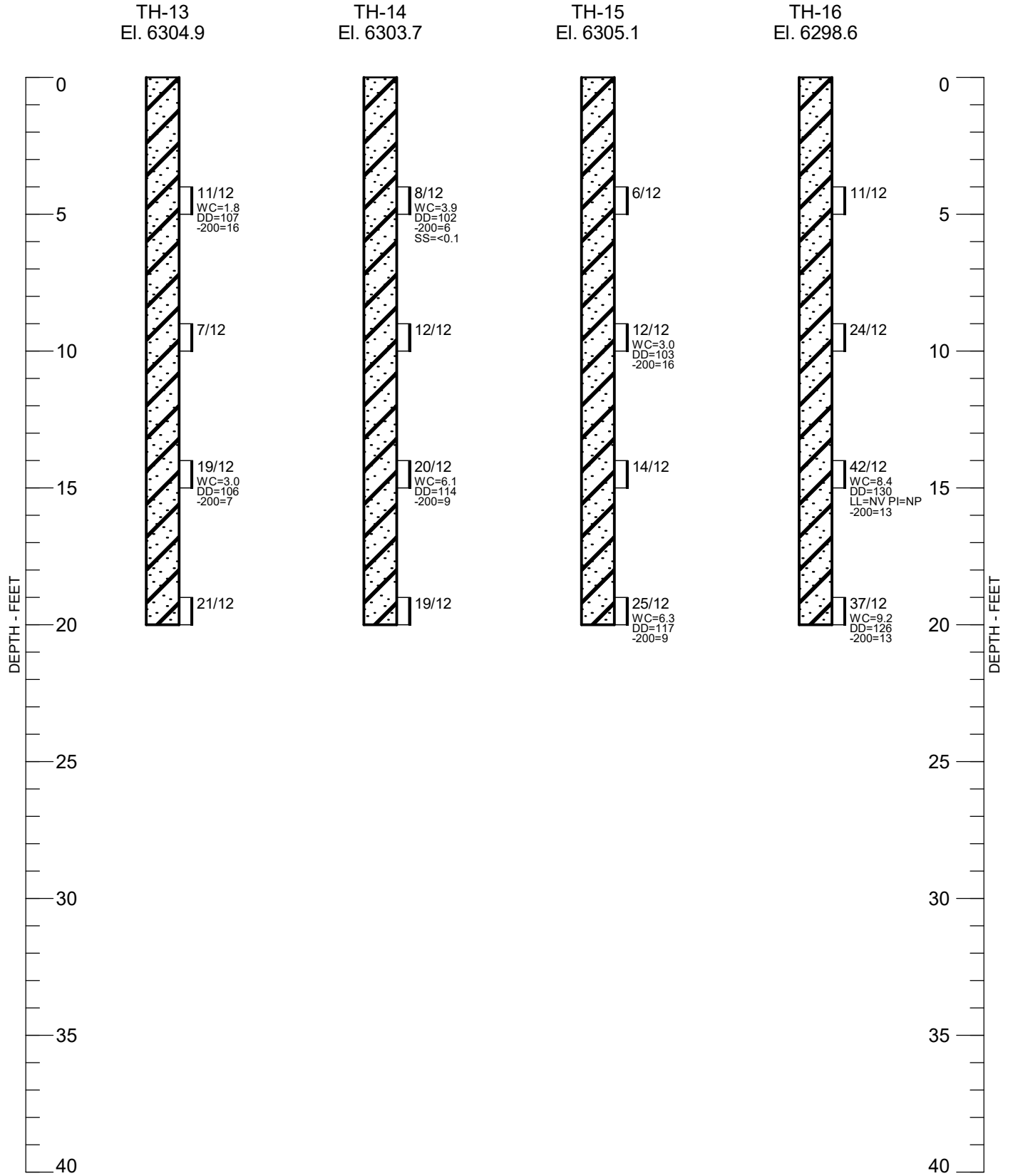

SUMMARY LOGS OF EXPLORATORY BORINGS

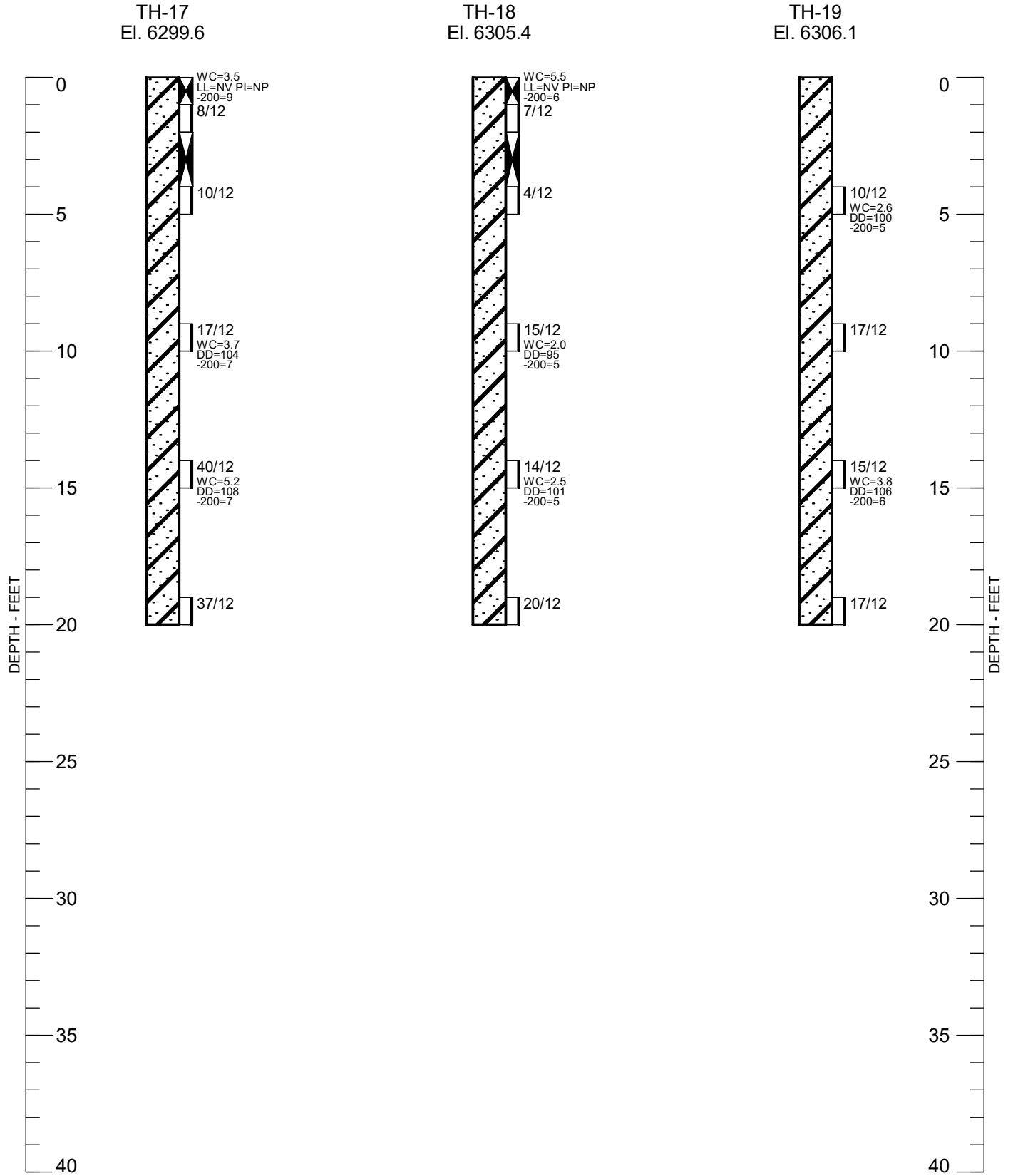

SUMMARY LOGS OF EXPLORATORY BORINGS

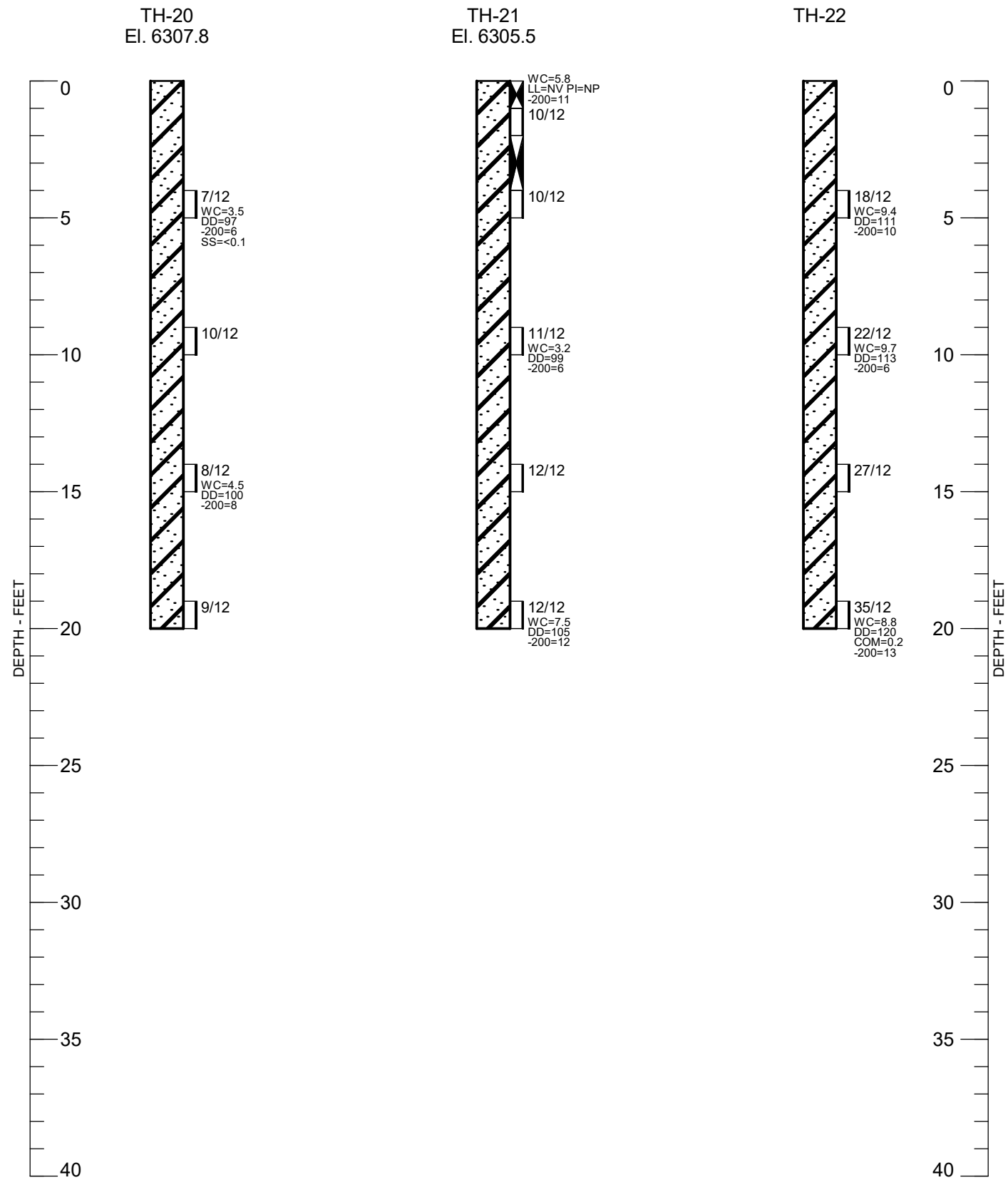

LEGEND:

- FILL, SAND, SILTY, LOOSE TO MEDIUM DENSE, SLIGHTLY MOIST, DARK BROWN.
- SAND, CLEAN TO SILTY, LOOSE TO DENSE, DRY TO SLIGHTLY MOIST, LIGHT TO MEDIUM BROWN (SP-SM, SM).
- BEDROCK, SANDSTONE, SLIGHTLY CLAYEY, VERY HARD, MOIST, MEDIUM BROWN, RUST.
- DRIVE SAMPLE. THE SYMBOL 7/12 INDICATES 7 BLOWS OF AN AUTOMATIC 140-POUND HAMMER FALLING 30 INCHES WERE REQUIRED TO DRIVE A 2.5-INCH O.D. SAMPLER 12 INCHES.
- BULK SAMPLE COLLECTED FROM AUGER CUTTINGS.

NOTES:

1. THE BORINGS WERE DRILLED ON MARCH 11, 12, 19, 25 AND 29, 2021 USING 4-INCH DIAMETER, CONTINUOUS-FLIGHT SOLID-STEM AUGER AND TRUCK-MOUNTED CME-45 DRILL RIG.
2. GROUNDWATER WAS NOT ENCOUNTERED DURING THIS INVESTIGATION.
3. WC - INDICATES MOISTURE CONTENT (%).
 DD - INDICATES DRY DENSITY (PCF).
 SW - INDICATES SWELL WHEN WETTED UNDER APPROXIMATE OVERBURDEN PRESSURE (%).
 COM - INDICATES COMPRESSION WHEN WETTED UNDER APPROXIMATE OVERBURDEN PRESSURE (%).
 LL - INDICATES LIQUID LIMIT.
 PI - INDICATES PLASTICITY INDEX.
 -200 - INDICATES PASSING NO. 200 SIEVE (%).
 SS - INDICATES WATER-SOLUBLE SULFATE CONTENT (%).
4. THESE LOGS ARE SUBJECT TO THE EXPLANATIONS, LIMITATIONS AND CONCLUSIONS CONTAINED IN THIS REPORT.

SUMMARY LOGS OF EXPLORATORY BORINGS

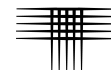

APPENDIX B

LABORATORY TEST RESULTS TABLE B-1: SUMMARY OF LABORATORY TESTING

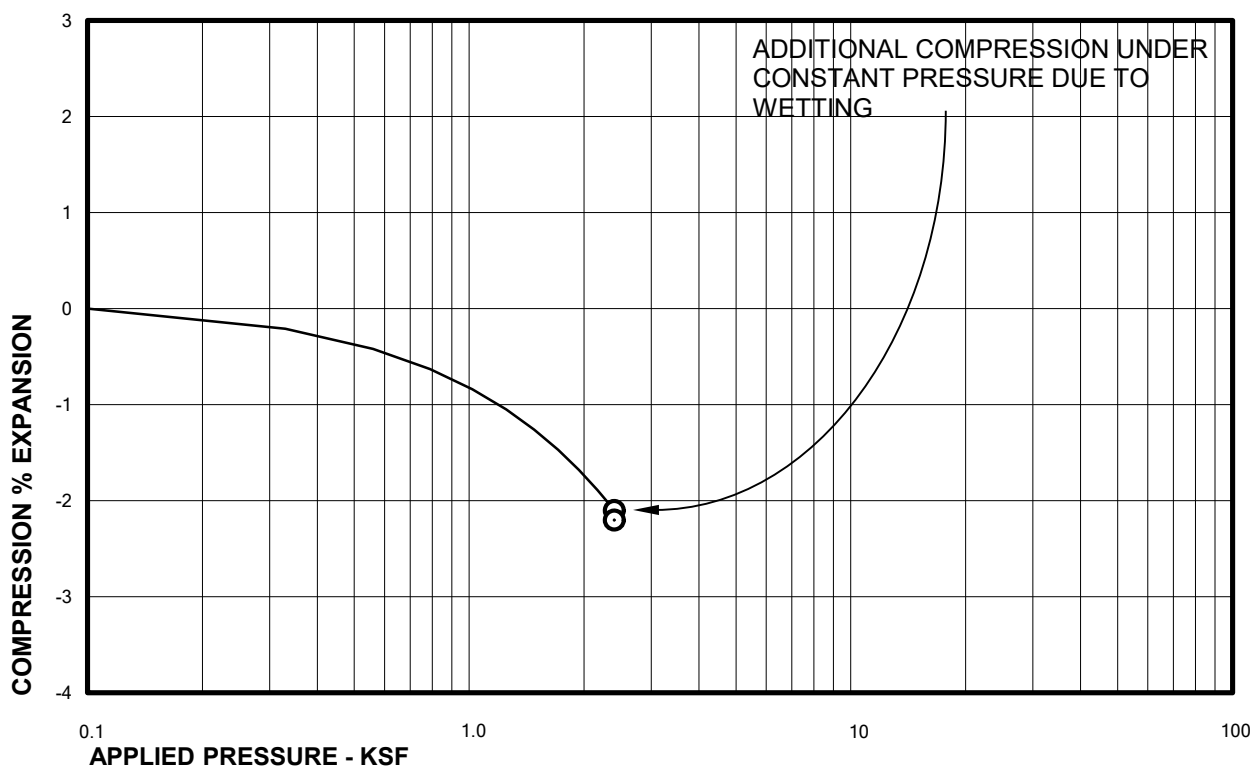
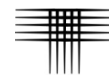

Sample of SAND, SILTY (SM)
From TH-1 AT 19 FEET

DRY UNIT WEIGHT= 121 PCF
MOISTURE CONTENT= 8.6 %

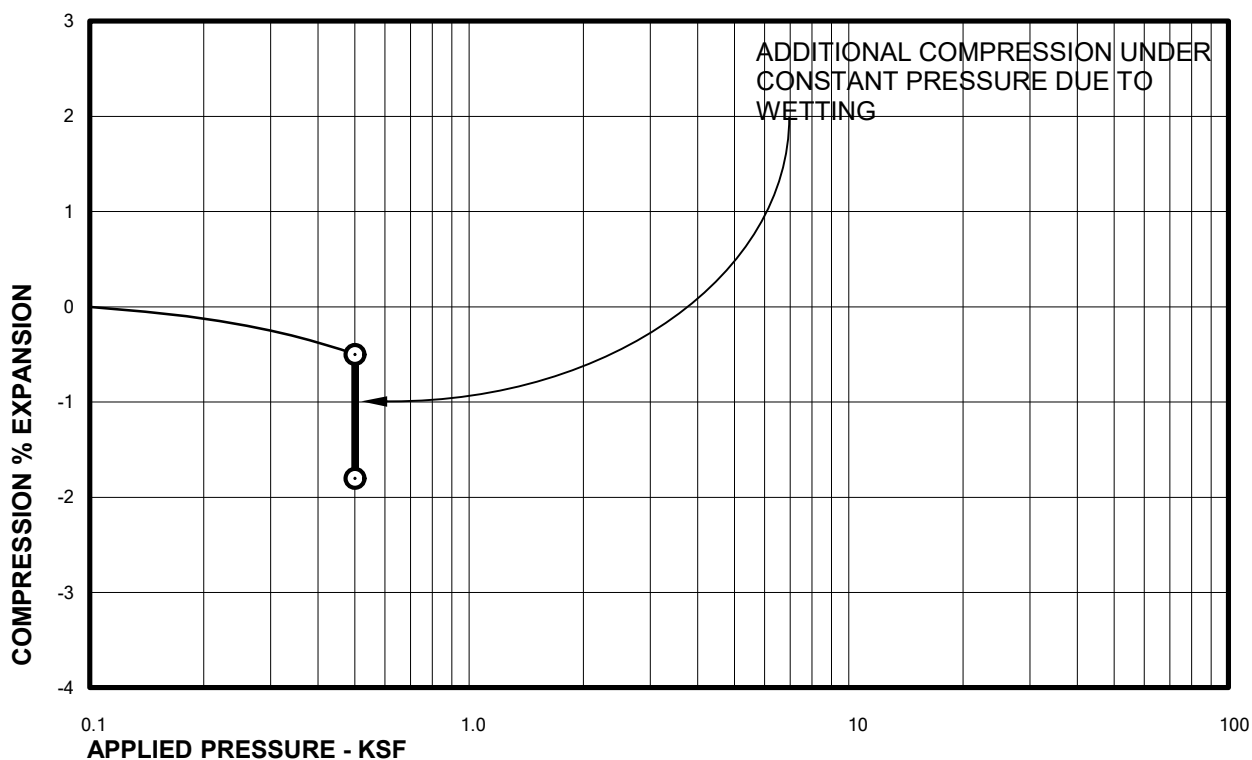

Sample of SAND, SILTY (SM)
From TH-3 AT 4 FEET

DRY UNIT WEIGHT= 100 PCF
MOISTURE CONTENT= 10.1 %

Swell Consolidation Test Results

FIG. B-1

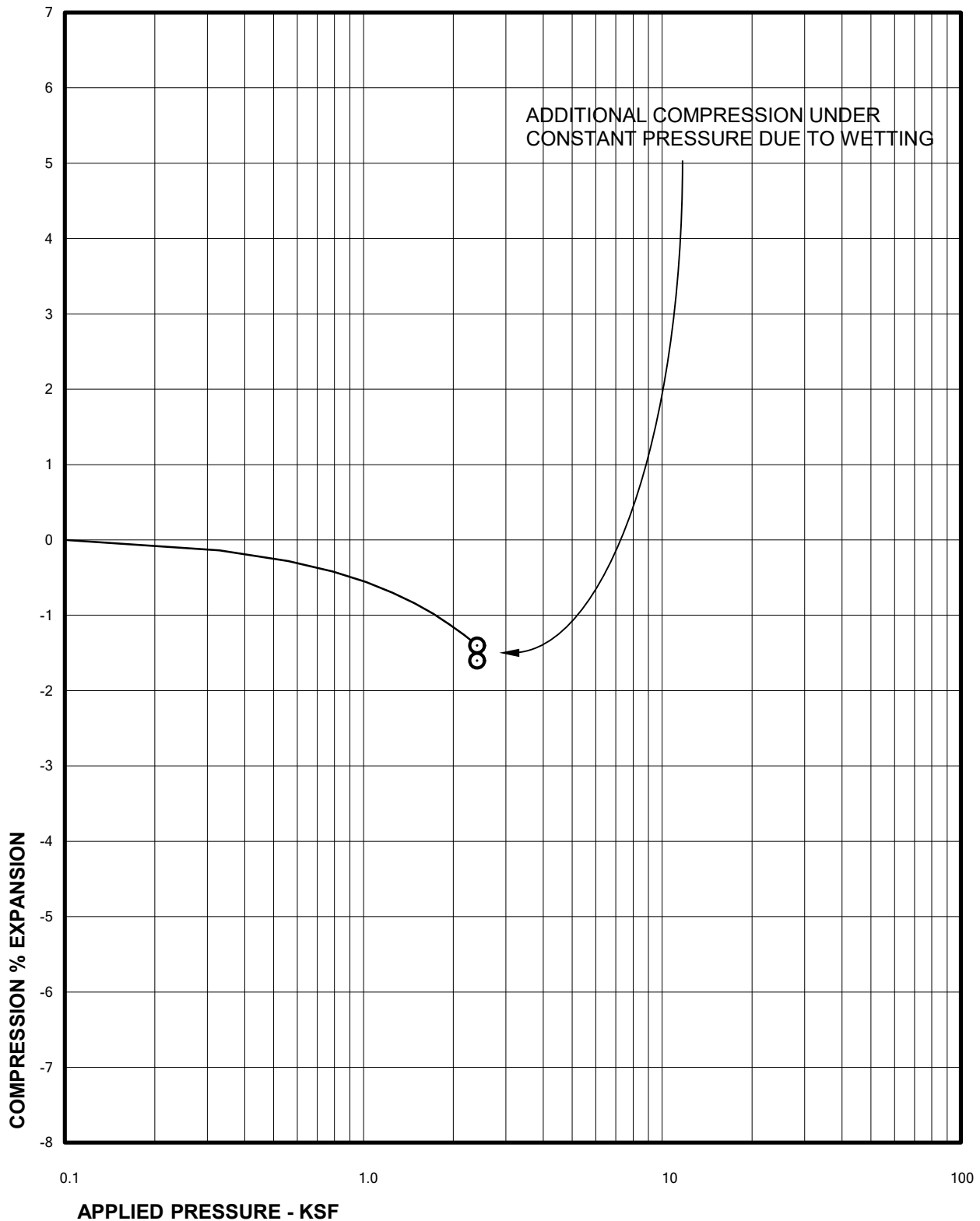
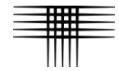

Sample of SAND, SILTY (SM)
From TH-22 AT 19 FEET

DRY UNIT WEIGHT= 120 PCF
MOISTURE CONTENT= 8.8 %

Swell Consolidation Test Results

FIG. B-2

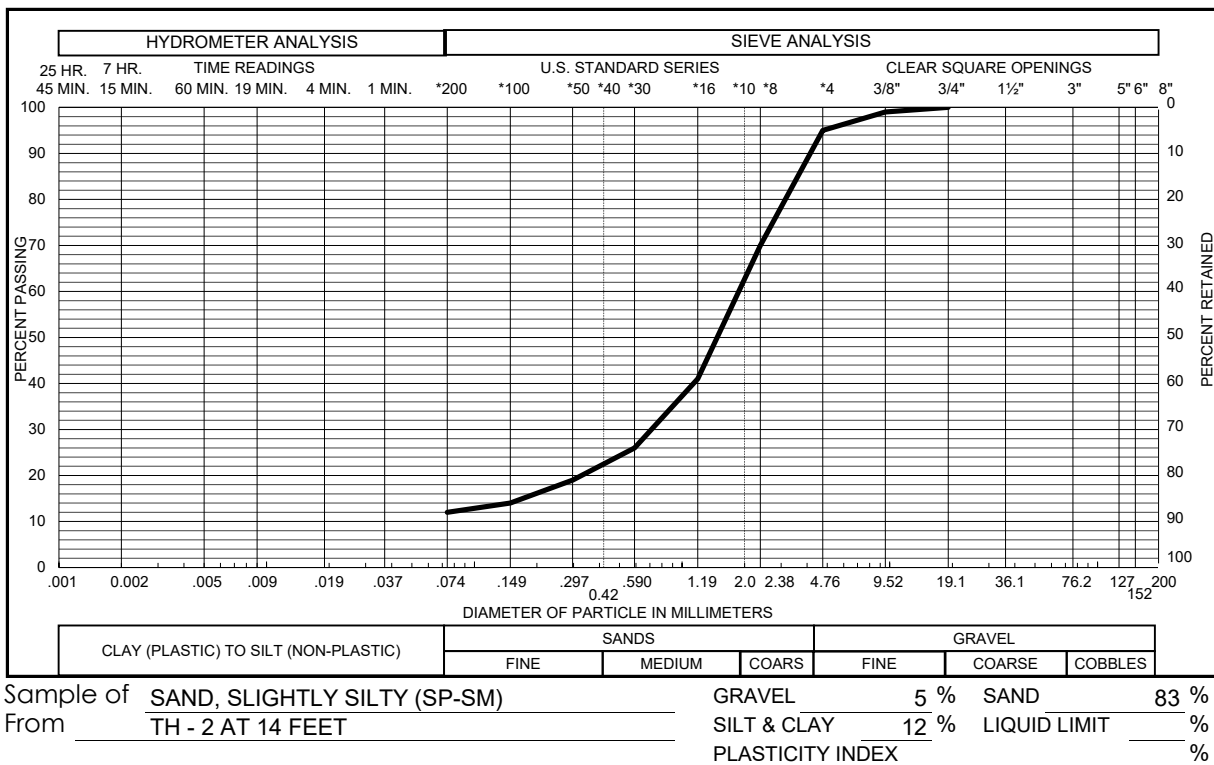
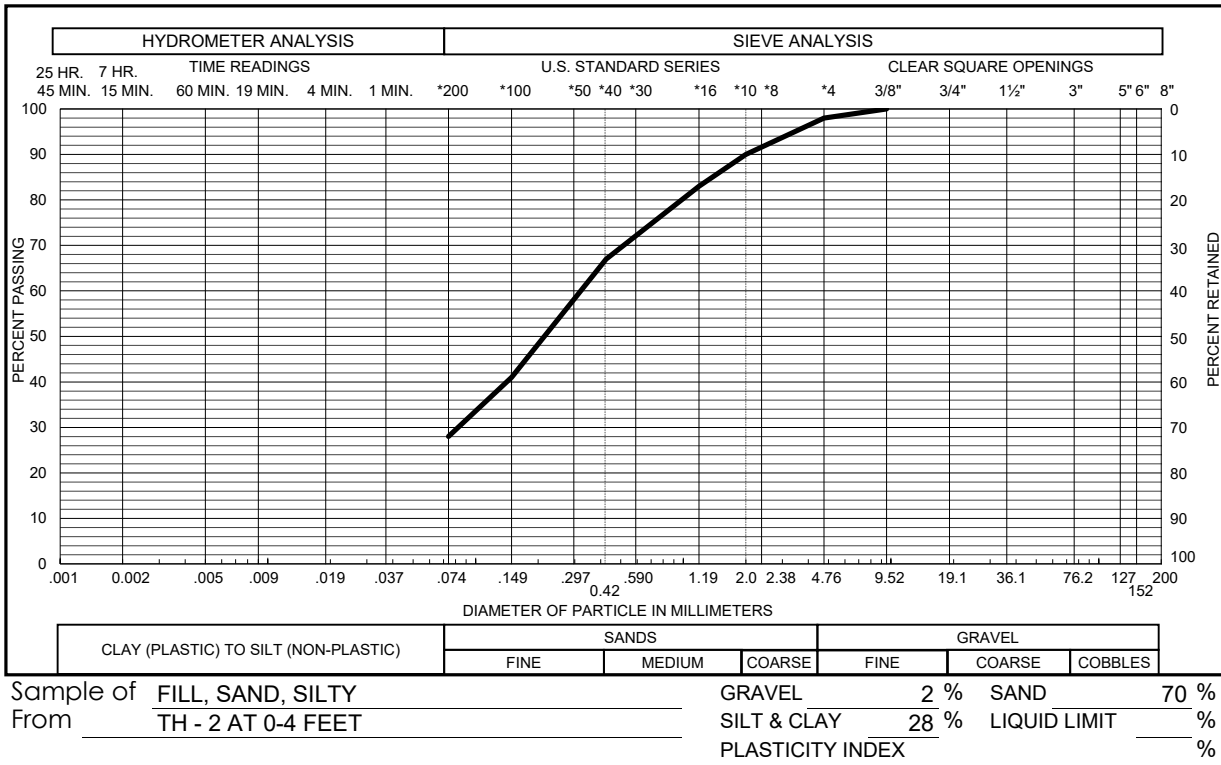
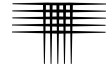

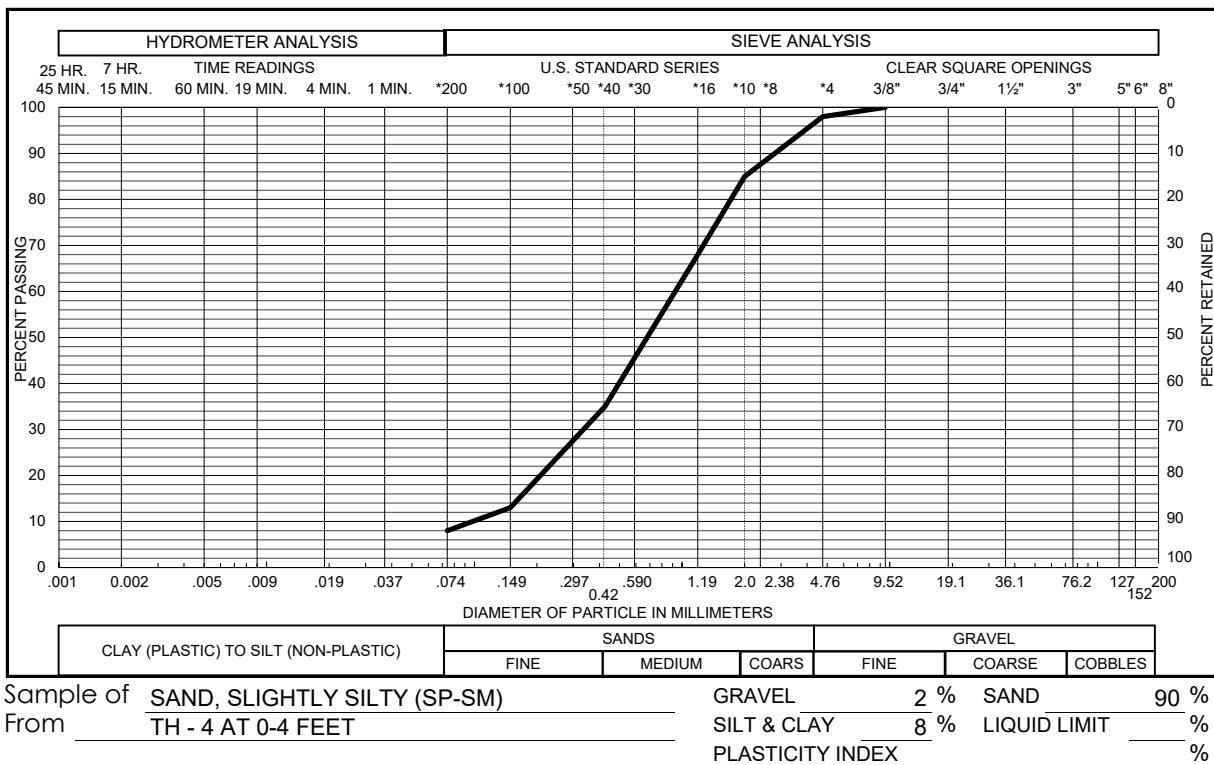
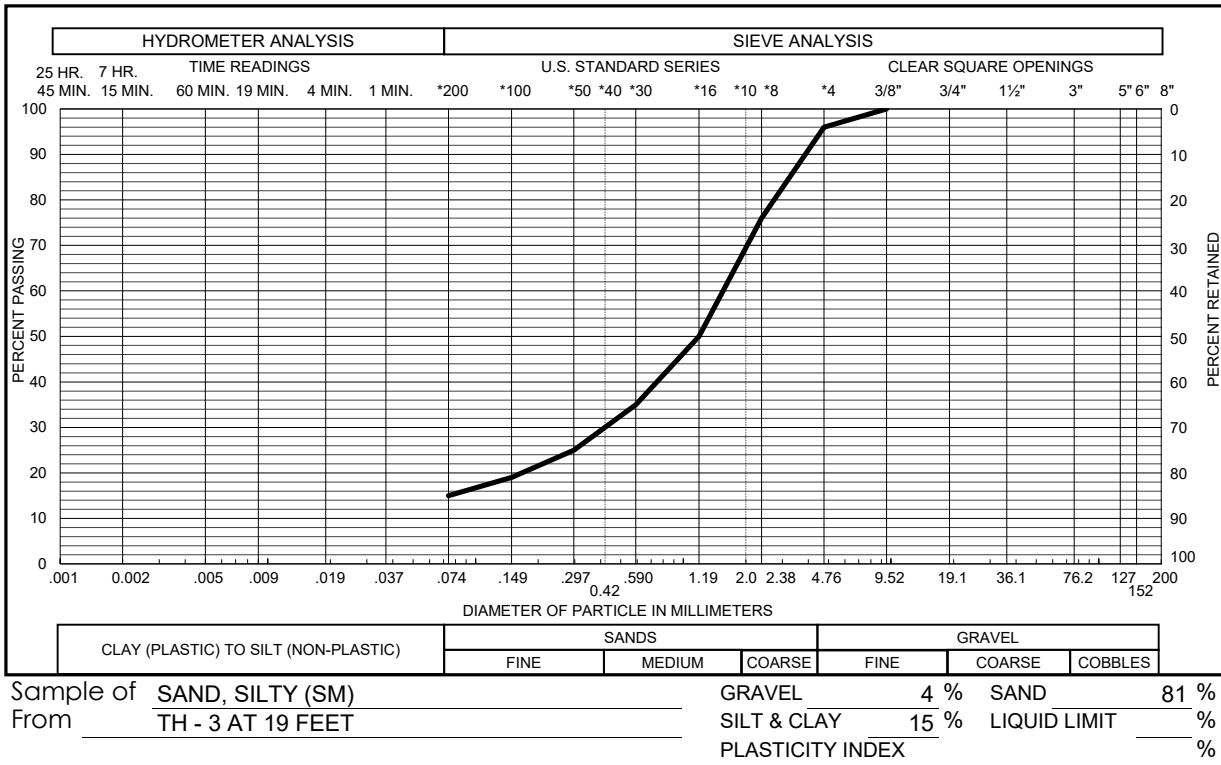
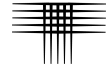

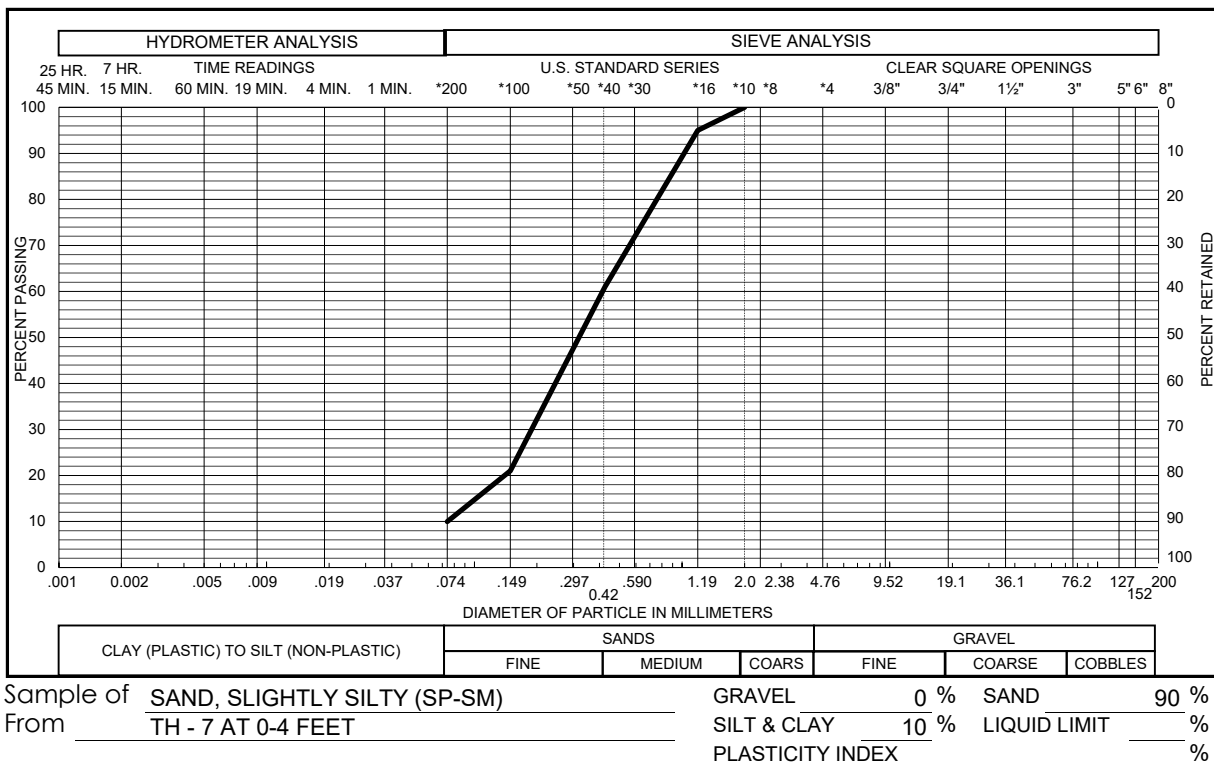
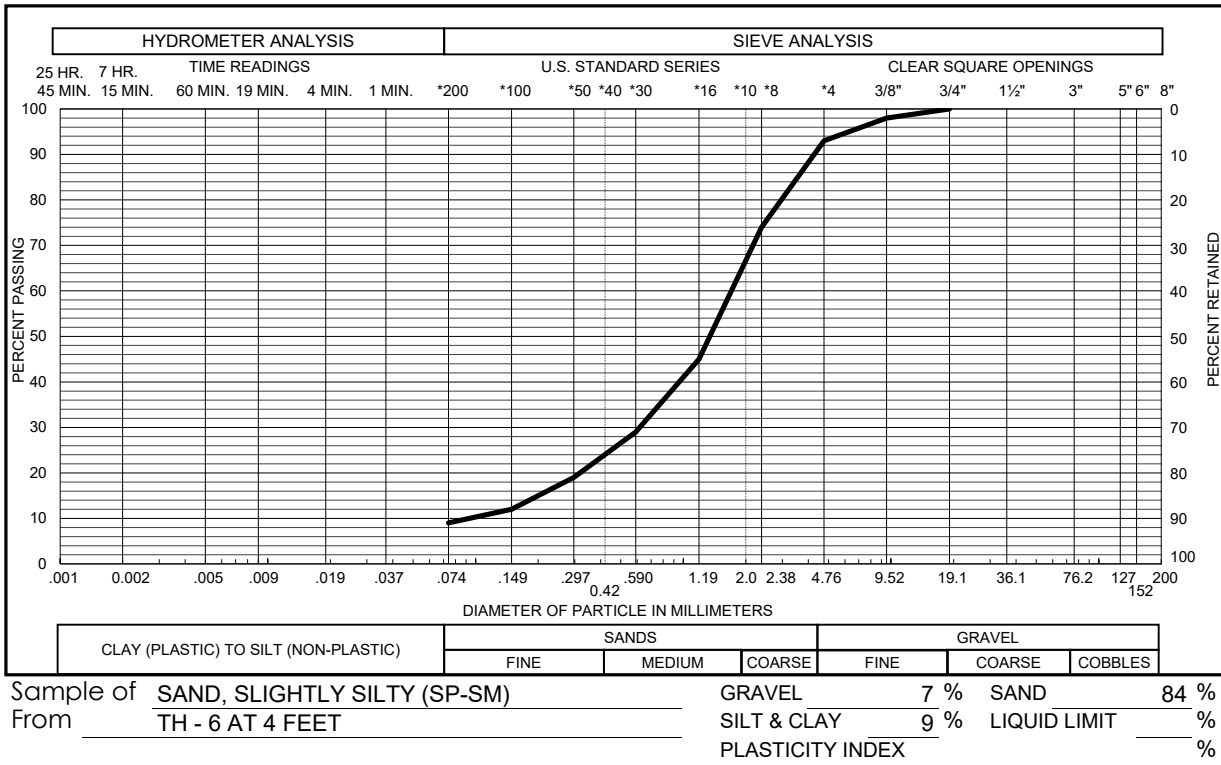
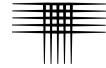

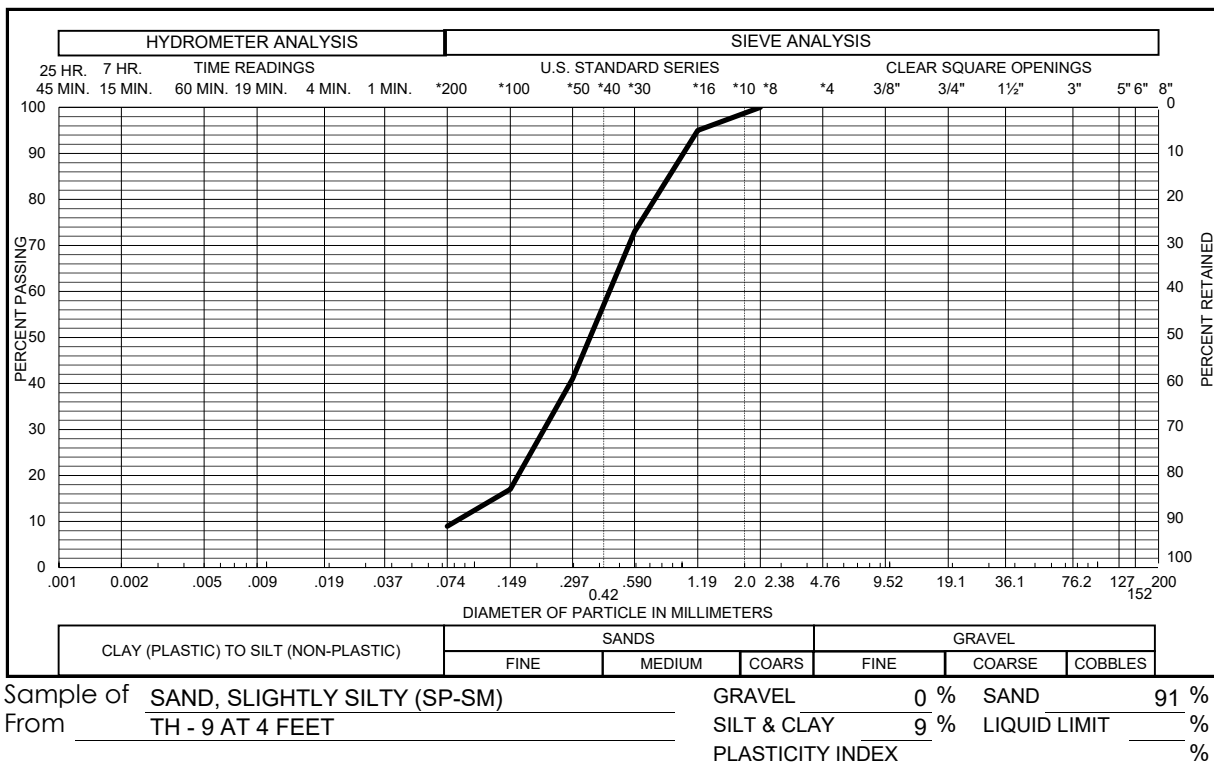
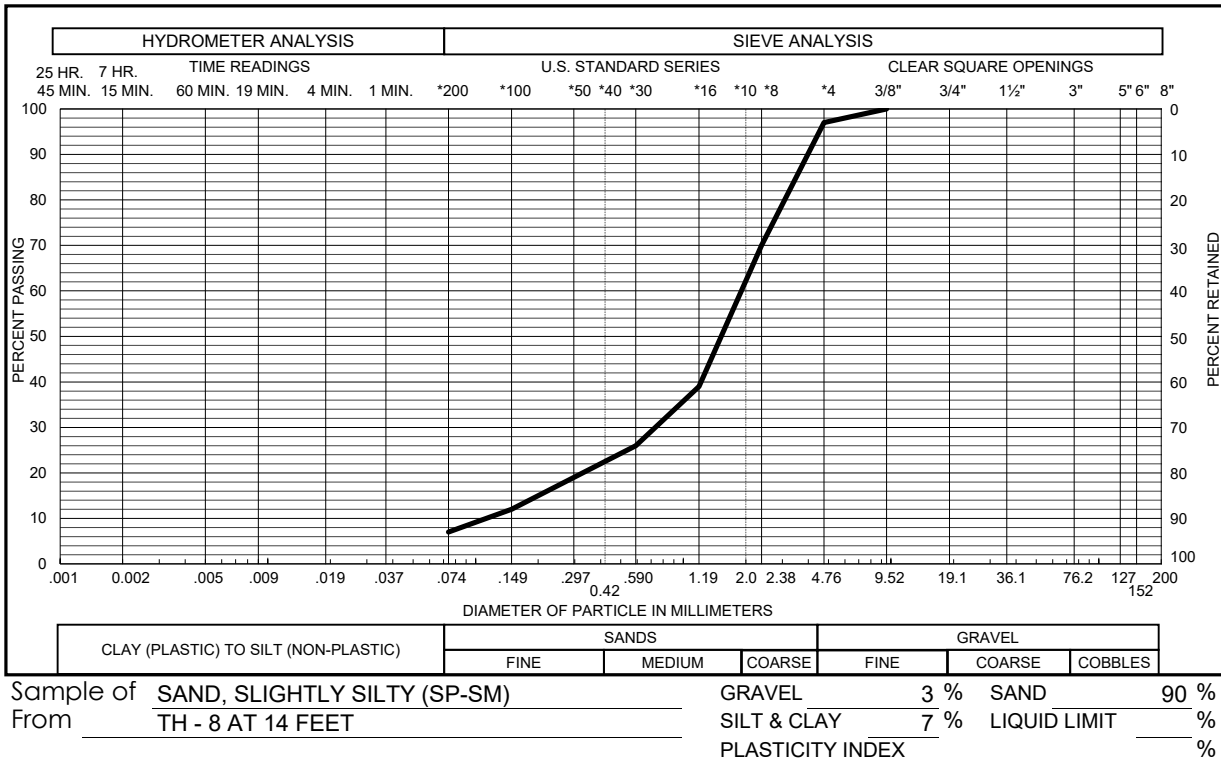
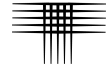

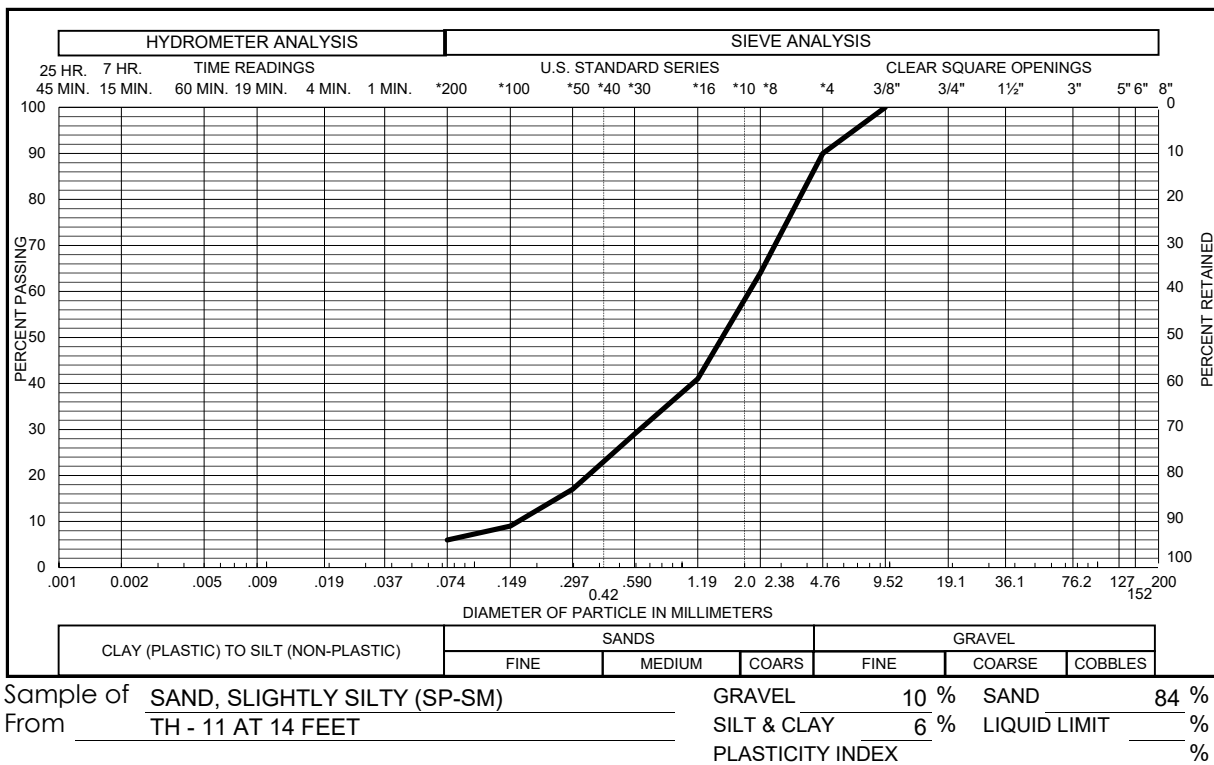
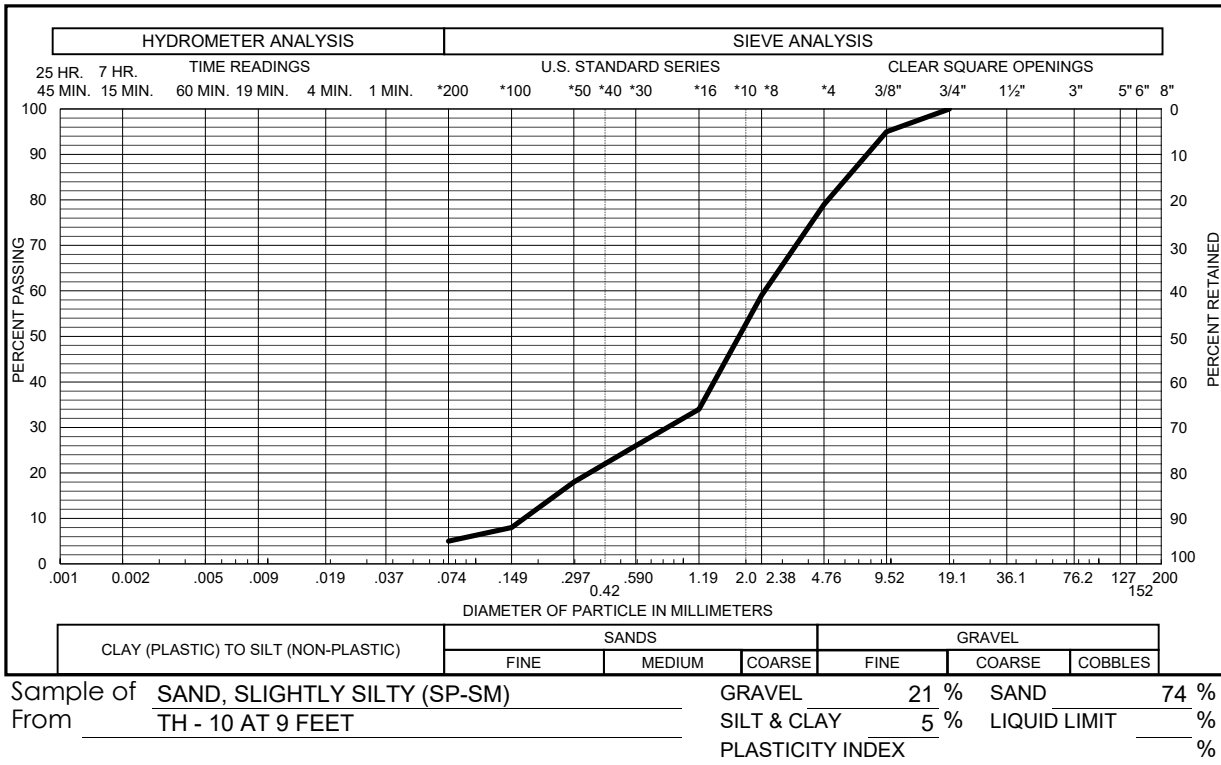
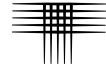

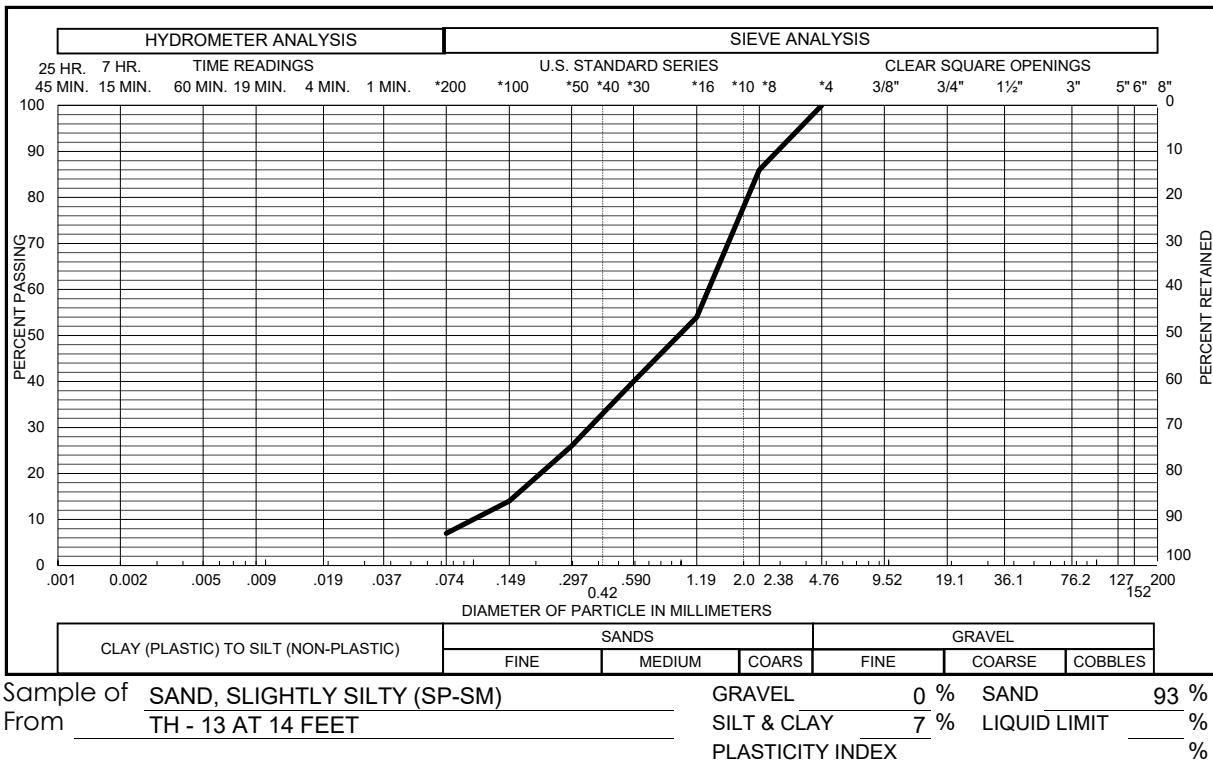
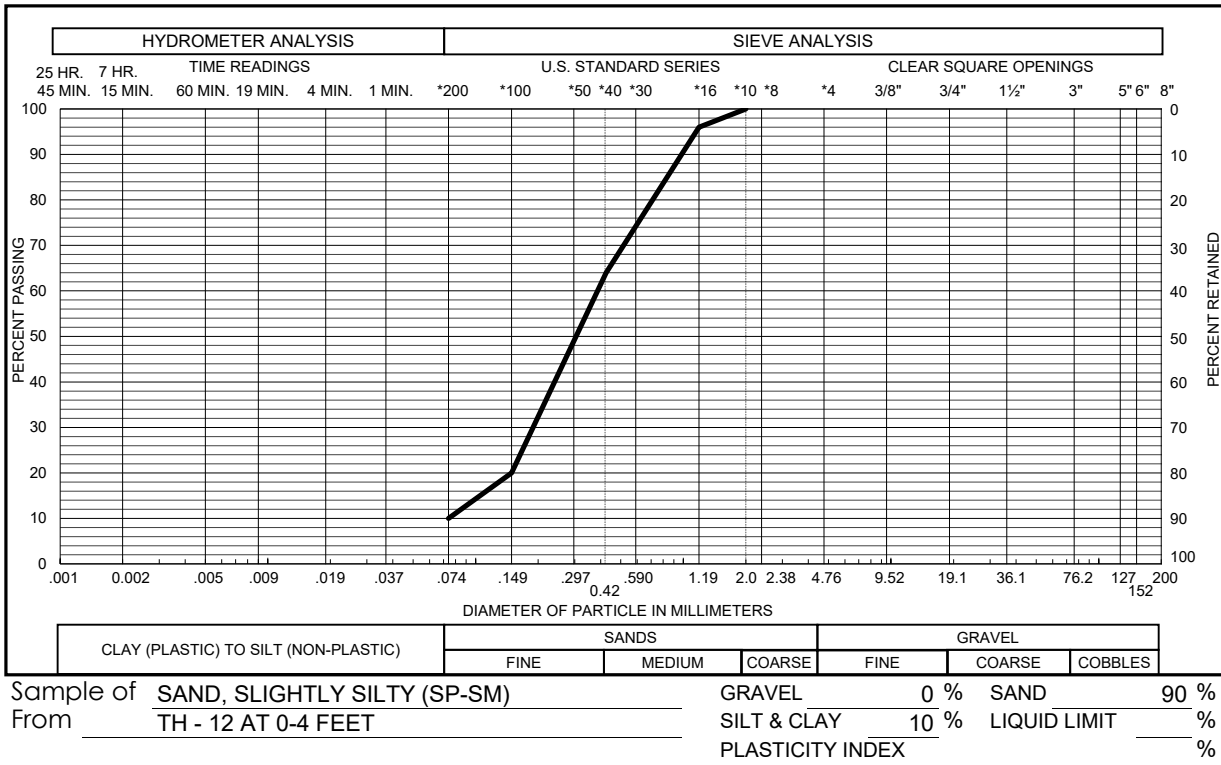
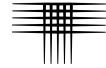

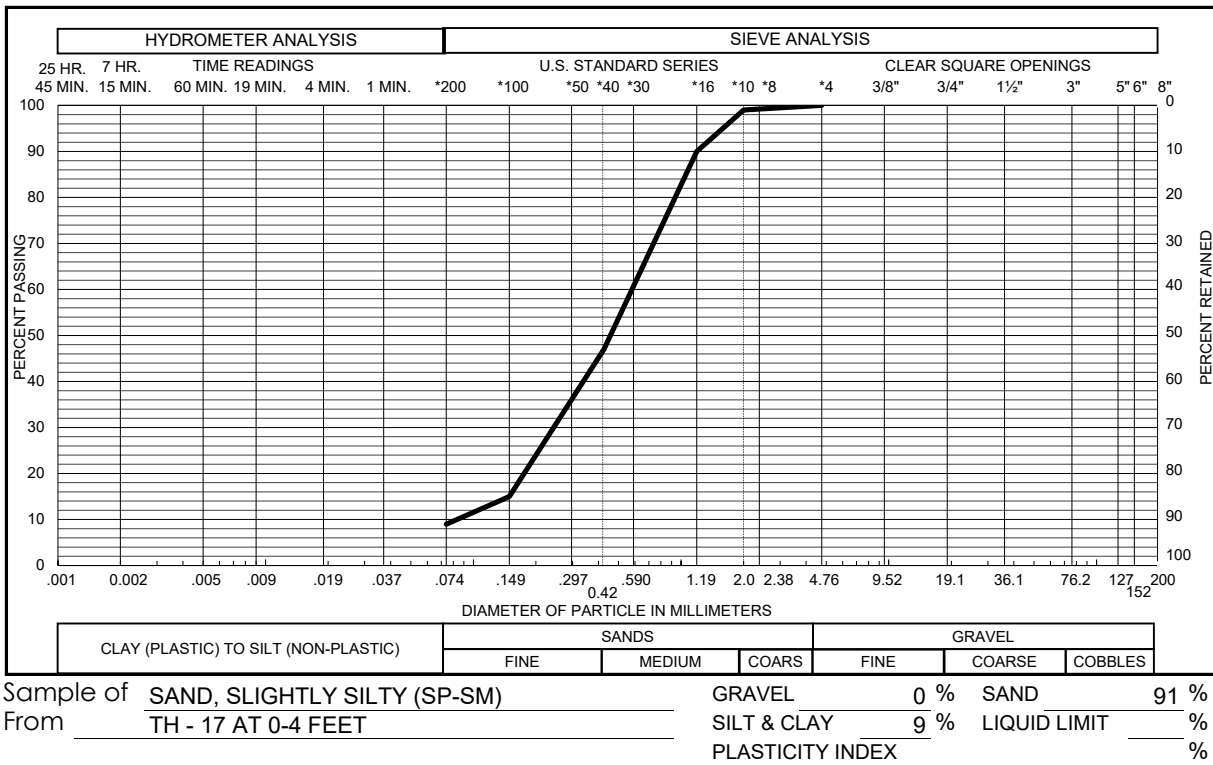
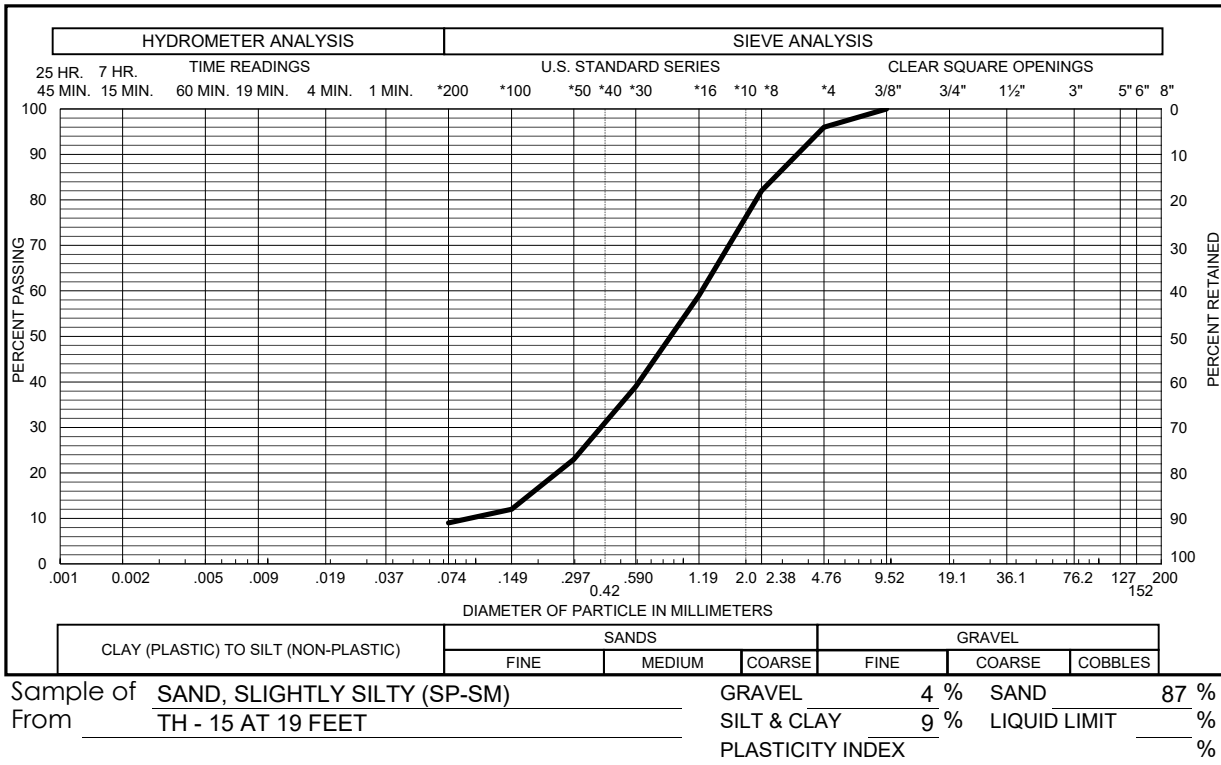
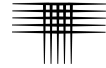

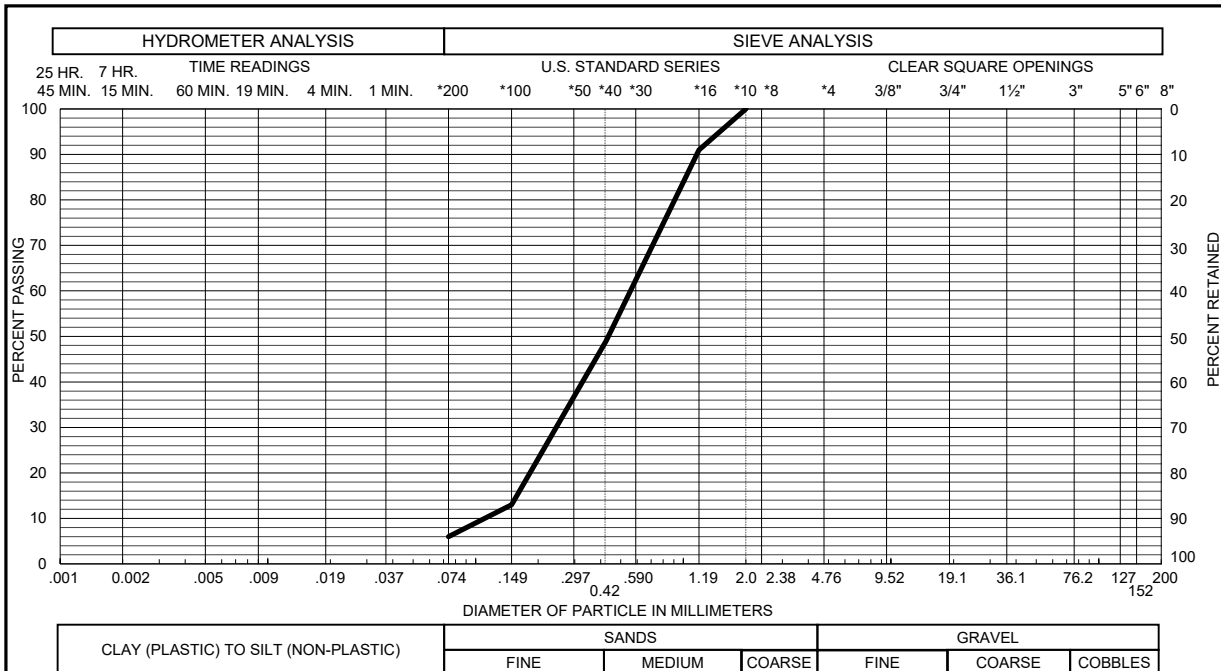
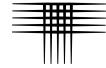

Sample of SAND, SLIGHTLY SILTY (SP-SM) GRAVEL 0 % SAND 94 %
 From TH - 18 AT 0-4 FEET SILT & CLAY 6 % LIQUID LIMIT %
 PLASTICITY INDEX %

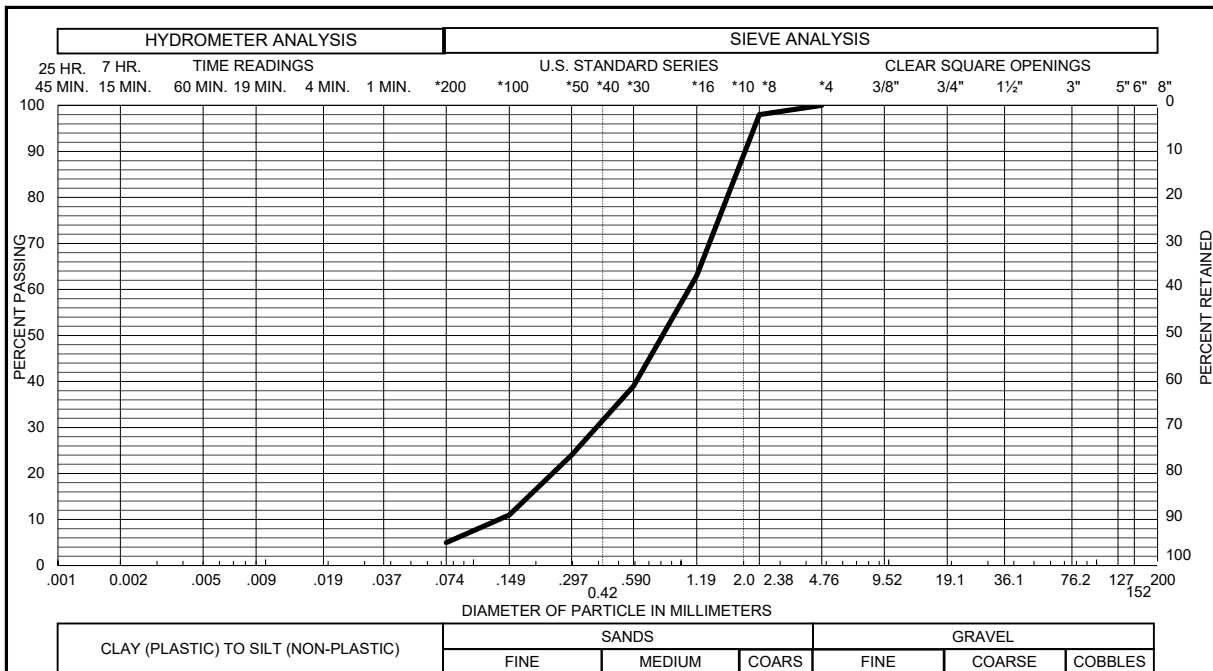

Sample of SAND, SLIGHTLY SILTY (SP-SM) GRAVEL 0 % SAND 95 %
 From TH - 19 AT 4 FEET SILT & CLAY 5 % LIQUID LIMIT %
 PLASTICITY INDEX %

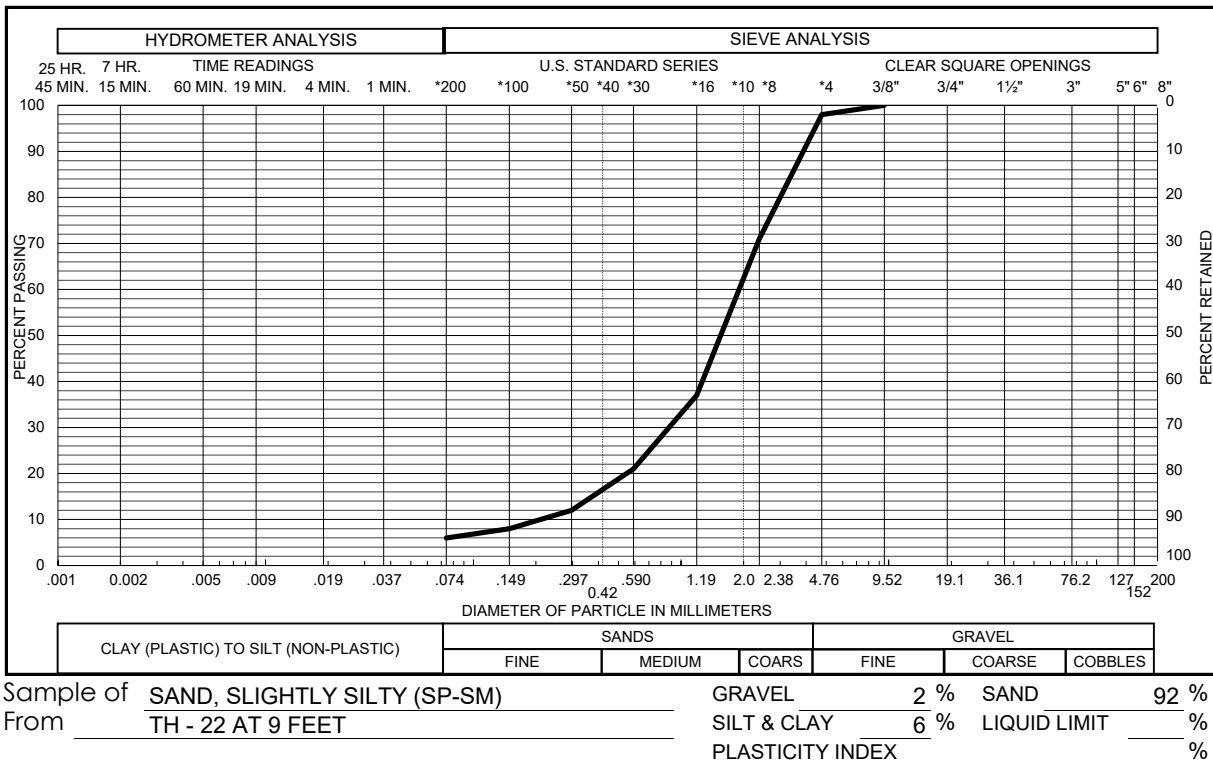
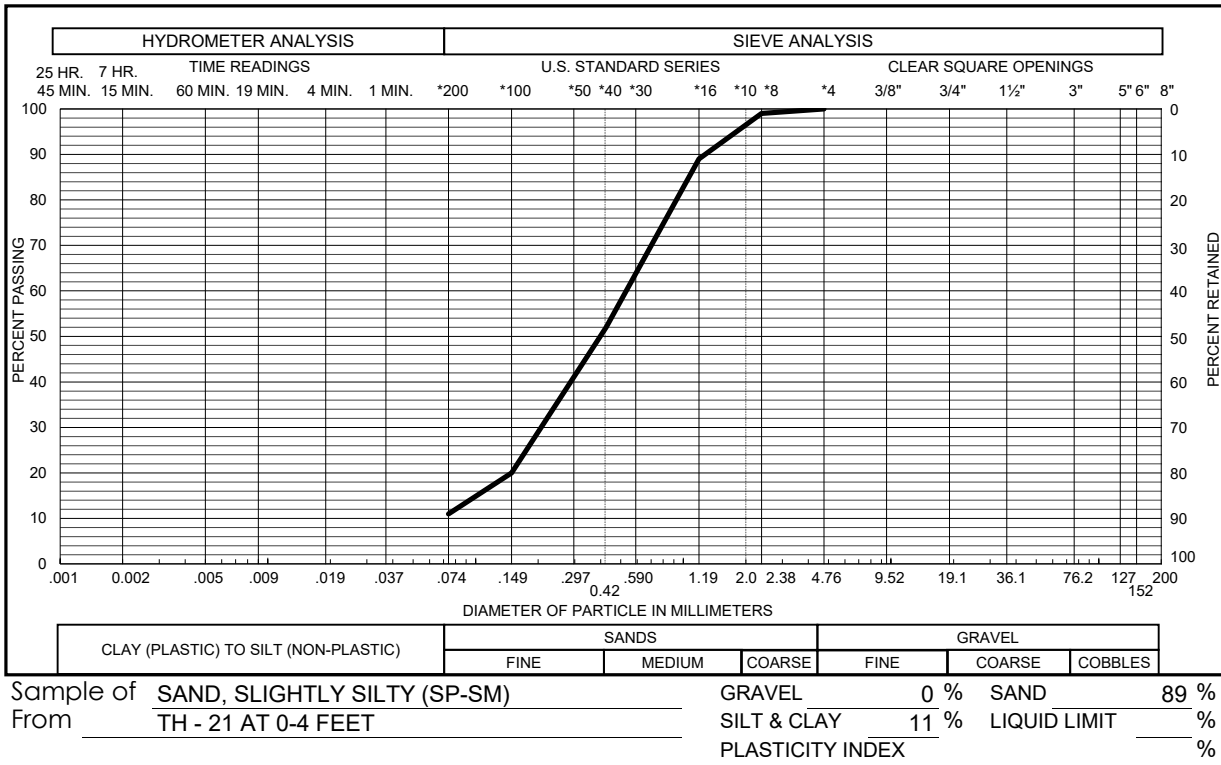
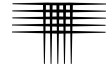

TABLE 1

**SUMMARY OF LABORATORY TESTING
CTLJT PROJECT NO. CS19308-125**



BORING	DEPTH (FEET)	MOISTURE CONTENT (%)	DRY DENSITY (PCF)	ATTERBERG LIMITS		SWELL TEST RESULTS*			PASSING NO. 200 SIEVE (%)	WATER SOLUBLE SULFATES (%)	DESCRIPTION
				LIQUID LIMIT (%)	PLASTICITY INDEX (%)	SWELL (%)	APPLIED PRESSURE (PSF)	SWELL PRESSURE (PSF)			
TH-1	14	9.4	126						23		SAND, SILTY (SM)
TH-1	19	8.6	121			-0.1	2400				SAND, SILTY (SM)
TH-2	0-4	8.4		23	2				28	<0.1	FILL, SAND, SILTY
TH-2	9	7.7	122						12		SAND, SLIGHTLY SILTY (SP-SM)
TH-2	14	9.0	127						12		SAND, SLIGHTLY SILTY (SP-SM)
TH-3	4	10.1	100			-1.3	500		35		SAND, SILTY (SM)
TH-3	19	8.8	125						15		SAND, SILTY (SM)
TH-4	0-4	5.0		NV	NP				8		SAND, SLIGHTLY SILTY (SP-SM)
TH-4	4	9.7	123						9	<0.1	SAND, SLIGHTLY SILTY (SP-SM)
TH-4	14	9.5	124						9		SAND, SLIGHTLY SILTY (SP-SM)
TH-5	4	5.4	107						11		SAND, SLIGHTLY SILTY (SP-SM)
TH-5	14	10.3	123						8		SAND, SLIGHTLY SILTY (SP-SM)
TH-6	4	8.5	120						9	<0.1	SAND, SLIGHTLY SILTY (SP-SM)
TH-6	9	9.5	121						10		SAND, SLIGHTLY SILTY (SP-SM)
TH-7	0-4	7.7		NV	NP				10		SAND, SLIGHTLY SILTY (SP-SM)
TH-7	4	4.0	101						5		SAND, SLIGHTLY SILTY (SP-SM)
TH-7	9	8.2	127						13		SAND, SILTY (SM)
TH-8	9	9.2	127						14		SAND, SILTY (SM)
TH-8	14	10.5	120						7		SAND, SLIGHTLY SILTY (SP-SM)
TH-9	4	1.6	99						9		SAND, SLIGHTLY SILTY (SP-SM)
TH-9	19	8.7	128						11		SAND, SLIGHTLY SILTY (SP-SM)
TH-10	9	8.6	111						5		SAND, SLIGHTLY SILTY (SP-SM)
TH-10	19	8.2	127						10		SAND, SLIGHTLY SILTY (SP-SM)
TH-11	4	4.1	104						8		SAND, SLIGHTLY SILTY (SP-SM)
TH-11	14	8.4	119						6		SAND, SLIGHTLY SILTY (SP-SM)
TH-12	0-4	3.4		NV	NP				10		SAND, SLIGHTLY SILTY (SP-SM)
TH-12	4	2.8	105						14		SAND, SILTY (SM)
TH-12	9	2.9	104						6		SAND, SLIGHTLY SILTY (SP-SM)
TH-13	4	1.8	107						16		SAND, SILTY (SM)
TH-13	14	3.0	106						7		SAND, SLIGHTLY SILTY (SP-SM)
TH-14	4	3.9	102						6	<0.1	SAND, SLIGHTLY SILTY (SP-SM)
TH-14	14	6.1	114						9		SAND, SLIGHTLY SILTY (SP-SM)
TH-15	9	3.0	103						16		SAND, SILTY (SM)

* SWELL MEASURED UNDER ESTIMATED IN-SITU OVERBURDEN PRESSURE.
NEGATIVE VALUE INDICATES COMPRESSION.

TABLE 1**SUMMARY OF LABORATORY TESTING
CTLJT PROJECT NO. CS19308-125**

BORING	DEPTH (FEET)	MOISTURE CONTENT (%)	DRY DENSITY (PCF)	ATTERBERG LIMITS		SWELL TEST RESULTS*			PASSING NO. 200 SIEVE (%)	WATER SOLUBLE SULFATES (%)	DESCRIPTION
				LIQUID LIMIT (%)	PLASTICITY INDEX (%)	SWELL (%)	APPLIED PRESSURE (PSF)	SWELL PRESSURE (PSF)			
TH-15	19	6.3	117						9		SAND, SLIGHTLY SILTY (SP-SM)
TH-16	14	8.4	130	NV	NP				13		SAND, SILTY (SM)
TH-16	19	9.2	126						13		SAND, SILTY (SM)

* SWELL MEASURED UNDER ESTIMATED IN-SITU OVERBURDEN PRESSURE.
NEGATIVE VALUE INDICATES COMPRESSION.



United States
Department of
Agriculture

NRCS

Natural
Resources
Conservation
Service

A product of the National
Cooperative Soil Survey,
a joint effort of the United
States Department of
Agriculture and other
Federal agencies, State
agencies including the
Agricultural Experiment
Stations, and local
participants

Custom Soil Resource Report for El Paso County Area, Colorado

Crossroads at Meadowbrook



Preface

Soil surveys contain information that affects land use planning in survey areas. They highlight soil limitations that affect various land uses and provide information about the properties of the soils in the survey areas. Soil surveys are designed for many different users, including farmers, ranchers, foresters, agronomists, urban planners, community officials, engineers, developers, builders, and home buyers. Also, conservationists, teachers, students, and specialists in recreation, waste disposal, and pollution control can use the surveys to help them understand, protect, or enhance the environment.

Various land use regulations of Federal, State, and local governments may impose special restrictions on land use or land treatment. Soil surveys identify soil properties that are used in making various land use or land treatment decisions. The information is intended to help the land users identify and reduce the effects of soil limitations on various land uses. The landowner or user is responsible for identifying and complying with existing laws and regulations.

Although soil survey information can be used for general farm, local, and wider area planning, onsite investigation is needed to supplement this information in some cases. Examples include soil quality assessments (<http://www.nrcs.usda.gov/wps/portal/nrcs/main/soils/health/>) and certain conservation and engineering applications. For more detailed information, contact your local USDA Service Center (<https://offices.sc.egov.usda.gov/locator/app?agency=nrcs>) or your NRCS State Soil Scientist (http://www.nrcs.usda.gov/wps/portal/nrcs/detail/soils/contactus/?cid=nrcs142p2_053951).

Great differences in soil properties can occur within short distances. Some soils are seasonally wet or subject to flooding. Some are too unstable to be used as a foundation for buildings or roads. Clayey or wet soils are poorly suited to use as septic tank absorption fields. A high water table makes a soil poorly suited to basements or underground installations.

The National Cooperative Soil Survey is a joint effort of the United States Department of Agriculture and other Federal agencies, State agencies including the Agricultural Experiment Stations, and local agencies. The Natural Resources Conservation Service (NRCS) has leadership for the Federal part of the National Cooperative Soil Survey.

Information about soils is updated periodically. Updated information is available through the NRCS Web Soil Survey, the site for official soil survey information.

The U.S. Department of Agriculture (USDA) prohibits discrimination in all its programs and activities on the basis of race, color, national origin, age, disability, and where applicable, sex, marital status, familial status, parental status, religion, sexual orientation, genetic information, political beliefs, reprisal, or because all or a part of an individual's income is derived from any public assistance program. (Not all prohibited bases apply to all programs.) Persons with disabilities who require

alternative means for communication of program information (Braille, large print, audiotape, etc.) should contact USDA's TARGET Center at (202) 720-2600 (voice and TDD). To file a complaint of discrimination, write to USDA, Director, Office of Civil Rights, 1400 Independence Avenue, S.W., Washington, D.C. 20250-9410 or call (800) 795-3272 (voice) or (202) 720-6382 (TDD). USDA is an equal opportunity provider and employer.

Contents

Preface	2
How Soil Surveys Are Made	5
Soil Map	8
Soil Map.....	9
Legend.....	10
Map Unit Legend.....	11
Map Unit Descriptions.....	11
El Paso County Area, Colorado.....	13
8—Blakeland loamy sand, 1 to 9 percent slopes.....	13
10—Blendon sandy loam, 0 to 3 percent slopes.....	14
References	16

How Soil Surveys Are Made

Soil surveys are made to provide information about the soils and miscellaneous areas in a specific area. They include a description of the soils and miscellaneous areas and their location on the landscape and tables that show soil properties and limitations affecting various uses. Soil scientists observed the steepness, length, and shape of the slopes; the general pattern of drainage; the kinds of crops and native plants; and the kinds of bedrock. They observed and described many soil profiles. A soil profile is the sequence of natural layers, or horizons, in a soil. The profile extends from the surface down into the unconsolidated material in which the soil formed or from the surface down to bedrock. The unconsolidated material is devoid of roots and other living organisms and has not been changed by other biological activity.

Currently, soils are mapped according to the boundaries of major land resource areas (MLRAs). MLRAs are geographically associated land resource units that share common characteristics related to physiography, geology, climate, water resources, soils, biological resources, and land uses (USDA, 2006). Soil survey areas typically consist of parts of one or more MLRA.

The soils and miscellaneous areas in a survey area occur in an orderly pattern that is related to the geology, landforms, relief, climate, and natural vegetation of the area. Each kind of soil and miscellaneous area is associated with a particular kind of landform or with a segment of the landform. By observing the soils and miscellaneous areas in the survey area and relating their position to specific segments of the landform, a soil scientist develops a concept, or model, of how they were formed. Thus, during mapping, this model enables the soil scientist to predict with a considerable degree of accuracy the kind of soil or miscellaneous area at a specific location on the landscape.

Commonly, individual soils on the landscape merge into one another as their characteristics gradually change. To construct an accurate soil map, however, soil scientists must determine the boundaries between the soils. They can observe only a limited number of soil profiles. Nevertheless, these observations, supplemented by an understanding of the soil-vegetation-landscape relationship, are sufficient to verify predictions of the kinds of soil in an area and to determine the boundaries.

Soil scientists recorded the characteristics of the soil profiles that they studied. They noted soil color, texture, size and shape of soil aggregates, kind and amount of rock fragments, distribution of plant roots, reaction, and other features that enable them to identify soils. After describing the soils in the survey area and determining their properties, the soil scientists assigned the soils to taxonomic classes (units). Taxonomic classes are concepts. Each taxonomic class has a set of soil characteristics with precisely defined limits. The classes are used as a basis for comparison to classify soils systematically. Soil taxonomy, the system of taxonomic classification used in the United States, is based mainly on the kind and character of soil properties and the arrangement of horizons within the profile. After the soil

Custom Soil Resource Report

scientists classified and named the soils in the survey area, they compared the individual soils with similar soils in the same taxonomic class in other areas so that they could confirm data and assemble additional data based on experience and research.

The objective of soil mapping is not to delineate pure map unit components; the objective is to separate the landscape into landforms or landform segments that have similar use and management requirements. Each map unit is defined by a unique combination of soil components and/or miscellaneous areas in predictable proportions. Some components may be highly contrasting to the other components of the map unit. The presence of minor components in a map unit in no way diminishes the usefulness or accuracy of the data. The delineation of such landforms and landform segments on the map provides sufficient information for the development of resource plans. If intensive use of small areas is planned, onsite investigation is needed to define and locate the soils and miscellaneous areas.

Soil scientists make many field observations in the process of producing a soil map. The frequency of observation is dependent upon several factors, including scale of mapping, intensity of mapping, design of map units, complexity of the landscape, and experience of the soil scientist. Observations are made to test and refine the soil-landscape model and predictions and to verify the classification of the soils at specific locations. Once the soil-landscape model is refined, a significantly smaller number of measurements of individual soil properties are made and recorded. These measurements may include field measurements, such as those for color, depth to bedrock, and texture, and laboratory measurements, such as those for content of sand, silt, clay, salt, and other components. Properties of each soil typically vary from one point to another across the landscape.

Observations for map unit components are aggregated to develop ranges of characteristics for the components. The aggregated values are presented. Direct measurements do not exist for every property presented for every map unit component. Values for some properties are estimated from combinations of other properties.

While a soil survey is in progress, samples of some of the soils in the area generally are collected for laboratory analyses and for engineering tests. Soil scientists interpret the data from these analyses and tests as well as the field-observed characteristics and the soil properties to determine the expected behavior of the soils under different uses. Interpretations for all of the soils are field tested through observation of the soils in different uses and under different levels of management. Some interpretations are modified to fit local conditions, and some new interpretations are developed to meet local needs. Data are assembled from other sources, such as research information, production records, and field experience of specialists. For example, data on crop yields under defined levels of management are assembled from farm records and from field or plot experiments on the same kinds of soil.

Predictions about soil behavior are based not only on soil properties but also on such variables as climate and biological activity. Soil conditions are predictable over long periods of time, but they are not predictable from year to year. For example, soil scientists can predict with a fairly high degree of accuracy that a given soil will have a high water table within certain depths in most years, but they cannot predict that a high water table will always be at a specific level in the soil on a specific date.

After soil scientists located and identified the significant natural bodies of soil in the survey area, they drew the boundaries of these bodies on aerial photographs and

Custom Soil Resource Report

identified each as a specific map unit. Aerial photographs show trees, buildings, fields, roads, and rivers, all of which help in locating boundaries accurately.

Soil Map

The soil map section includes the soil map for the defined area of interest, a list of soil map units on the map and extent of each map unit, and cartographic symbols displayed on the map. Also presented are various metadata about data used to produce the map, and a description of each soil map unit.

Custom Soil Resource Report Soil Map

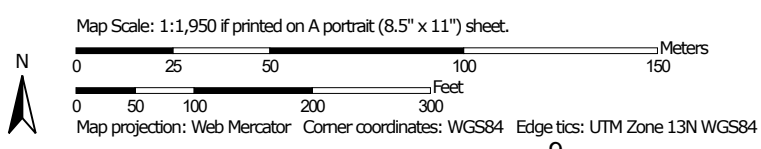
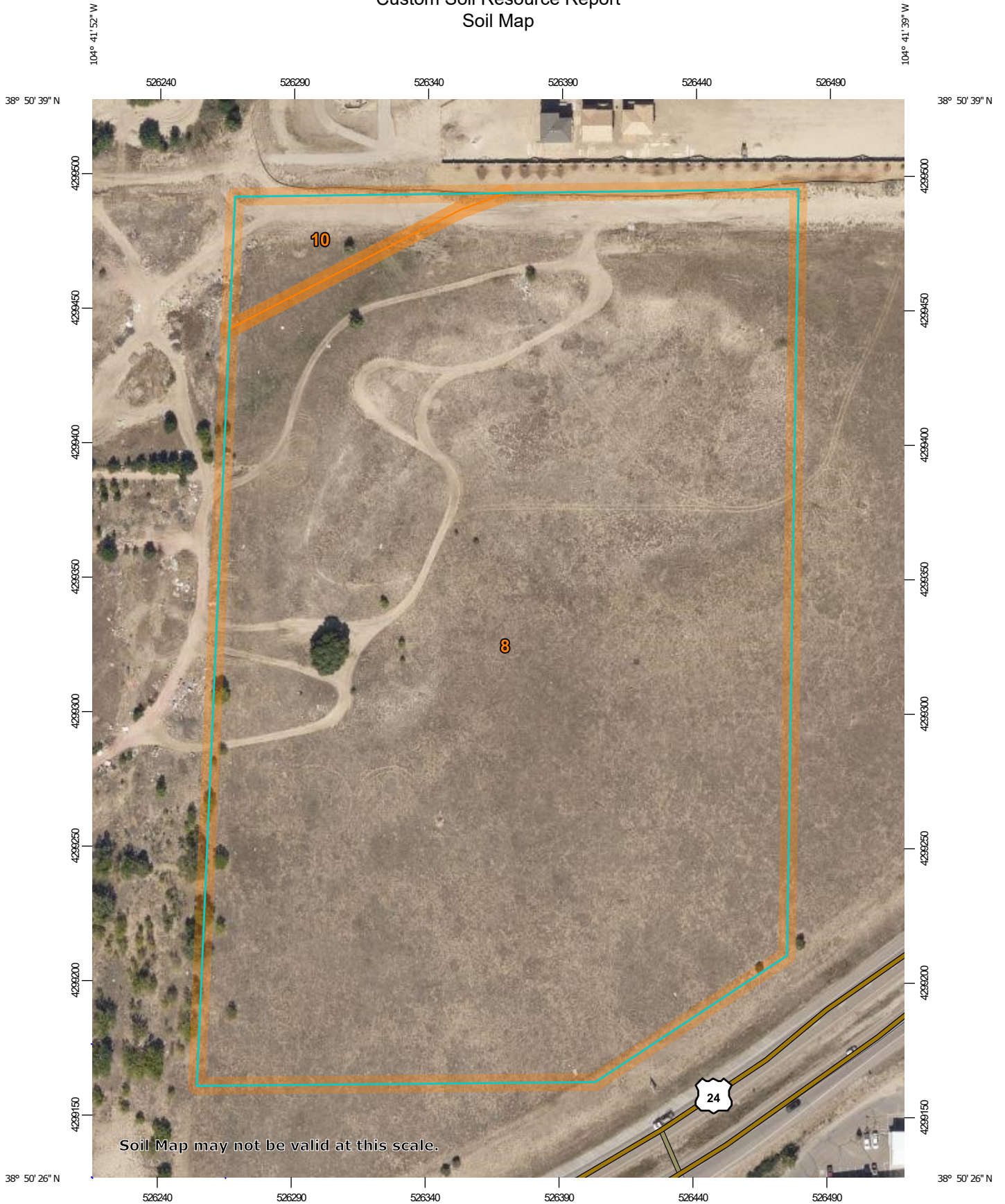

MAP LEGEND

Area of Interest (AOI)

 Area of Interest (AOI)



















Soils

 Soil Map Unit Polygons

 Soil Map Unit Lines

 Soil Map Unit Points

Special Point Features





-  Blowout
-  Borrow Pit
-  Clay Spot
-  Closed Depression
-  Gravel Pit
-  Gravelly Spot
-  Landfill
-  Lava Flow
-  Marsh or swamp
-  Mine or Quarry
-  Miscellaneous Water
-  Perennial Water
-  Rock Outcrop
-  Saline Spot
-  Sandy Spot
-  Severely Eroded Spot
-  Sinkhole
-  Slide or Slip
-  Sodic Spot

-  Spoil Area
-  Stony Spot
-  Very Stony Spot
-  Wet Spot
-  Other
-  Special Line Features

Water Features

 Streams and Canals

Transportation

-  Rails
-  Interstate Highways
-  US Routes
-  Major Roads
-  Local Roads

Background

 Aerial Photography

MAP INFORMATION

The soil surveys that comprise your AOI were mapped at 1:24,000.

Warning: Soil Map may not be valid at this scale.

Enlargement of maps beyond the scale of mapping can cause misunderstanding of the detail of mapping and accuracy of soil line placement. The maps do not show the small areas of contrasting soils that could have been shown at a more detailed scale.

Please rely on the bar scale on each map sheet for map measurements.

Source of Map: Natural Resources Conservation Service
 Web Soil Survey URL:
 Coordinate System: Web Mercator (EPSG:3857)

Maps from the Web Soil Survey are based on the Web Mercator projection, which preserves direction and shape but distorts distance and area. A projection that preserves area, such as the Albers equal-area conic projection, should be used if more accurate calculations of distance or area are required.

This product is generated from the USDA-NRCS certified data as of the version date(s) listed below.

Soil Survey Area: El Paso County Area, Colorado
 Survey Area Data: Version 18, Jun 5, 2020

Soil map units are labeled (as space allows) for map scales 1:50,000 or larger.

Date(s) aerial images were photographed: Aug 19, 2018—Sep 23, 2018

The orthophoto or other base map on which the soil lines were compiled and digitized probably differs from the background imagery displayed on these maps. As a result, some minor shifting of map unit boundaries may be evident.

Map Unit Legend

Map Unit Symbol	Map Unit Name	Acres in AOI	Percent of AOI
8	Blakeland loamy sand, 1 to 9 percent slopes	16.7	96.6%
10	Blendon sandy loam, 0 to 3 percent slopes	0.6	3.4%
Totals for Area of Interest		17.2	100.0%

Map Unit Descriptions

The map units delineated on the detailed soil maps in a soil survey represent the soils or miscellaneous areas in the survey area. The map unit descriptions, along with the maps, can be used to determine the composition and properties of a unit.

A map unit delineation on a soil map represents an area dominated by one or more major kinds of soil or miscellaneous areas. A map unit is identified and named according to the taxonomic classification of the dominant soils. Within a taxonomic class there are precisely defined limits for the properties of the soils. On the landscape, however, the soils are natural phenomena, and they have the characteristic variability of all natural phenomena. Thus, the range of some observed properties may extend beyond the limits defined for a taxonomic class. Areas of soils of a single taxonomic class rarely, if ever, can be mapped without including areas of other taxonomic classes. Consequently, every map unit is made up of the soils or miscellaneous areas for which it is named and some minor components that belong to taxonomic classes other than those of the major soils.

Most minor soils have properties similar to those of the dominant soil or soils in the map unit, and thus they do not affect use and management. These are called noncontrasting, or similar, components. They may or may not be mentioned in a particular map unit description. Other minor components, however, have properties and behavioral characteristics divergent enough to affect use or to require different management. These are called contrasting, or dissimilar, components. They generally are in small areas and could not be mapped separately because of the scale used. Some small areas of strongly contrasting soils or miscellaneous areas are identified by a special symbol on the maps. If included in the database for a given area, the contrasting minor components are identified in the map unit descriptions along with some characteristics of each. A few areas of minor components may not have been observed, and consequently they are not mentioned in the descriptions, especially where the pattern was so complex that it was impractical to make enough observations to identify all the soils and miscellaneous areas on the landscape.

The presence of minor components in a map unit in no way diminishes the usefulness or accuracy of the data. The objective of mapping is not to delineate pure taxonomic classes but rather to separate the landscape into landforms or landform segments that have similar use and management requirements. The delineation of such segments on the map provides sufficient information for the development of resource plans. If intensive use of small areas is planned, however,

Custom Soil Resource Report

onsite investigation is needed to define and locate the soils and miscellaneous areas.

An identifying symbol precedes the map unit name in the map unit descriptions. Each description includes general facts about the unit and gives important soil properties and qualities.

Soils that have profiles that are almost alike make up a *soil series*. Except for differences in texture of the surface layer, all the soils of a series have major horizons that are similar in composition, thickness, and arrangement.

Soils of one series can differ in texture of the surface layer, slope, stoniness, salinity, degree of erosion, and other characteristics that affect their use. On the basis of such differences, a soil series is divided into *soil phases*. Most of the areas shown on the detailed soil maps are phases of soil series. The name of a soil phase commonly indicates a feature that affects use or management. For example, Alpha silt loam, 0 to 2 percent slopes, is a phase of the Alpha series.

Some map units are made up of two or more major soils or miscellaneous areas. These map units are complexes, associations, or undifferentiated groups.

A *complex* consists of two or more soils or miscellaneous areas in such an intricate pattern or in such small areas that they cannot be shown separately on the maps. The pattern and proportion of the soils or miscellaneous areas are somewhat similar in all areas. Alpha-Beta complex, 0 to 6 percent slopes, is an example.

An *association* is made up of two or more geographically associated soils or miscellaneous areas that are shown as one unit on the maps. Because of present or anticipated uses of the map units in the survey area, it was not considered practical or necessary to map the soils or miscellaneous areas separately. The pattern and relative proportion of the soils or miscellaneous areas are somewhat similar. Alpha-Beta association, 0 to 2 percent slopes, is an example.

An *undifferentiated group* is made up of two or more soils or miscellaneous areas that could be mapped individually but are mapped as one unit because similar interpretations can be made for use and management. The pattern and proportion of the soils or miscellaneous areas in a mapped area are not uniform. An area can be made up of only one of the major soils or miscellaneous areas, or it can be made up of all of them. Alpha and Beta soils, 0 to 2 percent slopes, is an example.

Some surveys include *miscellaneous areas*. Such areas have little or no soil material and support little or no vegetation. Rock outcrop is an example.

El Paso County Area, Colorado

8—Blakeland loamy sand, 1 to 9 percent slopes

Map Unit Setting

National map unit symbol: 369v
Elevation: 4,600 to 5,800 feet
Mean annual precipitation: 14 to 16 inches
Mean annual air temperature: 46 to 48 degrees F
Frost-free period: 125 to 145 days
Farmland classification: Not prime farmland

Map Unit Composition

Blakeland and similar soils: 98 percent
Minor components: 2 percent
Estimates are based on observations, descriptions, and transects of the mapunit.

Description of Blakeland

Setting

Landform: Hills, flats
Landform position (three-dimensional): Side slope, talf
Down-slope shape: Linear
Across-slope shape: Linear
Parent material: Alluvium derived from sedimentary rock and/or eolian deposits derived from sedimentary rock

Typical profile

A - 0 to 11 inches: loamy sand
AC - 11 to 27 inches: loamy sand
C - 27 to 60 inches: sand

Properties and qualities

Slope: 1 to 9 percent
Depth to restrictive feature: More than 80 inches
Drainage class: Somewhat excessively drained
Runoff class: Low
Capacity of the most limiting layer to transmit water (Ksat): High to very high (5.95 to 19.98 in/hr)
Depth to water table: More than 80 inches
Frequency of flooding: None
Frequency of ponding: None
Calcium carbonate, maximum content: 5 percent
Available water capacity: Low (about 4.5 inches)

Interpretive groups

Land capability classification (irrigated): 3e
Land capability classification (nonirrigated): 6e
Hydrologic Soil Group: A
Ecological site: R049XB210CO - Sandy Foothill
Hydric soil rating: No

Minor Components

Pleasant

Percent of map unit: 1 percent

Custom Soil Resource Report

Landform: Depressions
Hydric soil rating: Yes

Other soils

Percent of map unit: 1 percent
Hydric soil rating: No

10—Blendon sandy loam, 0 to 3 percent slopes

Map Unit Setting

National map unit symbol: 3671
Elevation: 6,000 to 6,800 feet
Mean annual precipitation: 14 to 16 inches
Mean annual air temperature: 46 to 48 degrees F
Frost-free period: 125 to 145 days
Farmland classification: Not prime farmland

Map Unit Composition

Blendon and similar soils: 98 percent
Minor components: 2 percent
Estimates are based on observations, descriptions, and transects of the mapunit.

Description of Blendon

Setting

Landform: Terraces, alluvial fans
Down-slope shape: Linear
Across-slope shape: Linear
Parent material: Sandy alluvium derived from arkose

Typical profile

A - 0 to 10 inches: sandy loam
Bw - 10 to 36 inches: sandy loam
C - 36 to 60 inches: gravelly sandy loam

Properties and qualities

Slope: 0 to 3 percent
Depth to restrictive feature: More than 80 inches
Drainage class: Well drained
Runoff class: Low
Capacity of the most limiting layer to transmit water (Ksat): Moderately high to high
(0.60 to 2.00 in/hr)
Depth to water table: More than 80 inches
Frequency of flooding: None
Frequency of ponding: None
Calcium carbonate, maximum content: 2 percent
Available water capacity: Moderate (about 6.2 inches)

Interpretive groups

Land capability classification (irrigated): None specified
Land capability classification (nonirrigated): 3e

Custom Soil Resource Report

Hydrologic Soil Group: B

Ecological site: R049XB210CO - Sandy Foothill

Hydric soil rating: No

Minor Components

Pleasant

Percent of map unit: 1 percent

Landform: Depressions

Hydric soil rating: Yes

Other soils

Percent of map unit: 1 percent

Hydric soil rating: No

References

- American Association of State Highway and Transportation Officials (AASHTO). 2004. Standard specifications for transportation materials and methods of sampling and testing. 24th edition.
- American Society for Testing and Materials (ASTM). 2005. Standard classification of soils for engineering purposes. ASTM Standard D2487-00.
- Cowardin, L.M., V. Carter, F.C. Golet, and E.T. LaRoe. 1979. Classification of wetlands and deep-water habitats of the United States. U.S. Fish and Wildlife Service FWS/OBS-79/31.
- Federal Register. July 13, 1994. Changes in hydric soils of the United States.
- Federal Register. September 18, 2002. Hydric soils of the United States.
- Hurt, G.W., and L.M. Vasilas, editors. Version 6.0, 2006. Field indicators of hydric soils in the United States.
- National Research Council. 1995. Wetlands: Characteristics and boundaries.
- Soil Survey Division Staff. 1993. Soil survey manual. Soil Conservation Service. U.S. Department of Agriculture Handbook 18. http://www.nrcs.usda.gov/wps/portal/nrcs/detail/national/soils/?cid=nrcs142p2_054262
- Soil Survey Staff. 1999. Soil taxonomy: A basic system of soil classification for making and interpreting soil surveys. 2nd edition. Natural Resources Conservation Service, U.S. Department of Agriculture Handbook 436. http://www.nrcs.usda.gov/wps/portal/nrcs/detail/national/soils/?cid=nrcs142p2_053577
- Soil Survey Staff. 2010. Keys to soil taxonomy. 11th edition. U.S. Department of Agriculture, Natural Resources Conservation Service. http://www.nrcs.usda.gov/wps/portal/nrcs/detail/national/soils/?cid=nrcs142p2_053580
- Tiner, R.W., Jr. 1985. Wetlands of Delaware. U.S. Fish and Wildlife Service and Delaware Department of Natural Resources and Environmental Control, Wetlands Section.
- United States Army Corps of Engineers, Environmental Laboratory. 1987. Corps of Engineers wetlands delineation manual. Waterways Experiment Station Technical Report Y-87-1.
- United States Department of Agriculture, Natural Resources Conservation Service. National forestry manual. http://www.nrcs.usda.gov/wps/portal/nrcs/detail/soils/home/?cid=nrcs142p2_053374
- United States Department of Agriculture, Natural Resources Conservation Service. National range and pasture handbook. <http://www.nrcs.usda.gov/wps/portal/nrcs/detail/national/landuse/rangepasture/?cid=stelprdb1043084>

Custom Soil Resource Report

United States Department of Agriculture, Natural Resources Conservation Service. National soil survey handbook, title 430-VI. http://www.nrcs.usda.gov/wps/portal/nrcs/detail/soils/scientists/?cid=nrcs142p2_054242

United States Department of Agriculture, Natural Resources Conservation Service. 2006. Land resource regions and major land resource areas of the United States, the Caribbean, and the Pacific Basin. U.S. Department of Agriculture Handbook 296. http://www.nrcs.usda.gov/wps/portal/nrcs/detail/national/soils/?cid=nrcs142p2_053624

United States Department of Agriculture, Soil Conservation Service. 1961. Land capability classification. U.S. Department of Agriculture Handbook 210. http://www.nrcs.usda.gov/Internet/FSE_DOCUMENTS/nrcs142p2_052290.pdf

APPENDIX C – Standard Operating Procedures

Crossroads at Meadowbrook Standard Operating Procedure (SOP)

Minor Spill of Material (Paint, Stain, Solvent, Glue) (Less than Reportable Quantity)

A. Purpose

The purpose of this Standard Operating Procedure is to establish uniform procedures for clean up and disposal of material from a minor accidental spill of paint, stain, solvent, or glue. The procedures outlined in this SOP are applicable to all personnel working on the Aura at Crossroads construction site. Clean up and proper disposal of spilled material into the soil or onto the ground surface is required to ensure the material or contaminated soil does not enter or impact the waters of the state or the sanitary sewer system.

B. Summary of the Method

This procedure outlines the steps to be taken to prevent spilled material from impacting waters of the state and disposal of the resulting contaminated cleanup material.

C. Definitions

1. Material Safety Data Sheet (MSDS). The standard industry list for a product detailing the chemical make-up, safety hazards, first aid, fire fighting, and spill cleanup measures, handling, storage, and disposal methods

D. Health and Safety Warnings

Many construction materials may be flammable, cause skin and eye irritation, and may be harmful or fatal if swallowed. Caution should be used during clean up operations. The MSDS for the spilled material should be consulted to ensure personnel safety during cleanup operations.

E. Equipment and Supplies

1. Absorbent pads and booms
2. Hand equipment (shovels, brooms)
3. Waste containers (5 gallon buckets, drums)
4. Personal Protective Equipment

F. Procedural Steps

1. Shut down all equipment operating in the area to prevent ignition of the spill.
2. Quickly control the spill by stopping or securing the spill source. This could be as simple as up-righting a tipped container or shutting down a piece of equipment producing the spill.
3. Contact the Responsible Person on site to enact the emergency response contact procedure.

- a. Responsible Person shall consult the MSDS for proper spill procedures and determination of Reportable Quantity for a spill. In the event the spilled quantity exceeds the reportable quantity the Responsible Person shall contact:
 1. Call 911 for fire control if necessary.
 2. Colorado Environmental Release and Incident Reporting Hotline (1-877-518-5608)
 3. El Paso County Dispatch: (719) 520-6460
 - b. A release of any chemical, oil, petroleum product, sewage, etc., which may enter waters of the State of Colorado (which include surface water, ground water, and dry gullies or storm sewers leading to surface water) must be reported to CDPHE immediately (25-8-601 CRS).
4. Prevent migration of the spill by using an absorbent. This could include absorbent pads or booms, floor dry, cat litter, or dirt. The absorbent should be spread across the spill and along the downhill side to stop any flow.
 5. If necessary to prevent the material from entering a storm inlet or manhole a dam of absorbent material should be placed in the gutter upstream from the inlet.
 6. Begin cleanup of the spilled material and absorbents by placing the materials in 5 gallon, plastic buckets with lids or into a provided drum.
 7. Continue cleanup until all spilled material and contaminated absorbents are removed. On a hard surface this should include sweeping of the area. Material spilled on dirt should be removed down to a level where discoloration of the soil has been removed. Water shall never be used to flush material off a surface.
 8. All material shall be properly stored in a location designated by the Responsible Person on site.
 9. The Responsible Person shall contact the Site Contracted Emergency Response and Disposal Co. to collect and properly dispose of the material.
 10. Location of the spill will be documented on the Stormwater Maintenance Plan (SWMP) in the construction trailer.
 11. Inspection of materials and equipment shall occur daily.

G. Record Management

All documentation from the incident, including incident report and incident disposal manifests, shall be maintained at Trinsic Acquisition Company LLC, 8235 Douglas Avenue, Suite 950, Dallas, TX Ph: (970) 819-9968, for a period of 3 years from the date of the spill.

H. After Incident Briefing

All personnel involved in the incident shall attend a debriefing to determine the cause of the spill, procedures followed, and corrective actions to prevent future spills. All pertinent data shall be documented. All findings from the debriefing

should be discussed at the next Safety Meeting. County of El Paso shall be notified.

Standard Operating Procedure (SOP)

Minor Fuel or Oil Spill (Less than 5 Gallons)

A. Purpose

The purpose of this Standard Operating Procedure is to establish a uniform procedure for clean up and disposal of material from a minor accidental spill of fuel (gasoline or diesel) or oil (hydraulic or motor). The procedures outlined in this SOP are applicable to all personnel working on the Aura at Crossroads construction site. Clean up and proper disposal of spilled fuel or oil into the soil or onto the ground surface is required to ensure the material or contaminated soil does not enter or impact the waters of the state or the sanitary sewer system.

B. Summary of the Method

This procedure outlines the steps to be taken to prevent spilled fuel or oil from impacting waters of the state and disposal of the resulting contaminated cleanup material.

C. Definitions

1. Material Safety Data Sheet (MSDS). The standard industry list for a product detailing the chemical make-up, safety hazards, first aid, fire fighting, and spill cleanup measures, handling, storage, and disposal methods

D. Health and Safety Warnings

Fuels and fuel oils may be extremely flammable, cause skin and eye irritation, and may be harmful or fatal if swallowed. Caution should be used during clean up operations. The MSDS for the spilled material should be consulted to ensure personnel safety during cleanup operations.

E. Equipment and Supplies

1. Absorbent pads and booms
2. Hand equipment (shovels, brooms)
3. Waste containers (5 gallon buckets, drums)
4. Personal Protective Equipment

F. Procedural Steps

1. Shut down all equipment operating in the area to prevent ignition of the spill.
2. Quickly control the spill by stopping or securing the spill source. This could be as simple as up-righting a tipped container or shutting down a piece of equipment producing the spill.
3. Contact the Responsible Person on site to enact the emergency response contact procedure.
 - a. Responsible Person shall consult the MSDS for proper spill procedures and determination of Reportable Quantity for a spill.

In the event the spilled quantity exceeds the reportable quantity the Responsible Person shall contact:

1. Call 911 for fire control if necessary.
 2. Colorado Environmental Release and Incident Reporting Hotline (1-877-518-5608)
 3. El Paso County Dispatch: (719) 520-6460
- b. A release of any chemical, oil, petroleum product, sewage, etc., which may enter waters of the State of Colorado (which include surface water, ground water, and dry gullies or storm sewers leading to surface water) must be reported to CDPHE immediately (25-8-601 CRS).
4. Prevent migration of the spill by using an absorbent. This could include absorbent pads or booms, floor dry, cat litter, or dirt. The absorbent should be spread across the spill and along the downhill side to stop any flow.
 5. If necessary to prevent the material from entering a storm inlet or manhole a dam of absorbent material should be placed in the gutter upstream from the inlet.
 6. Begin cleanup of the spilled material and absorbents by placing the materials in 5 gallon, plastic buckets with lids or into a provided drum.
 7. Continue cleanup until all spilled material and contaminated absorbents are removed. On a hard surface this should include sweeping of the area. Material spilled on dirt should be removed down to a level where discoloration of the soil has been removed. Water shall never be used to flush material off a surface.
 8. All material shall be properly stored in a location designated by the Responsible Person on site.
 9. The Responsible Person shall contact the Site Contracted Emergency Response and Disposal Co to collect and properly dispose of the material.
 10. Location of the spill will be documented on the Stormwater Maintenance Plan (SWMP) in the construction trailer.
 11. Inspection of materials and equipment shall occur daily.

G. Record Management

All documentation from the incident, including incident report and incident disposal manifests, shall be maintained at Trinsic Acquisition Company LLC, 8235 Douglas Avenue, Suite 950, Dallas, TX Ph: (970) 819-9968, for a period of 3 years from the date of the spill.

H. After Incident Briefing

All personnel involved in the incident shall attend a debriefing to determine the cause of the spill, procedures followed, and corrective actions to prevent future spills. All pertinent data will be recorded. All findings from the debriefing should be discussed at the next Safety Meeting. County of El Paso shall be notified.

Standard Operating Procedure (SOP)

Small Fuel or Oil Spill (5 Gallons to Less than 25 Gallons)

A. Purpose

The purpose of this Standard Operating Procedure is to establish a uniform procedure for clean up and disposal of material from a small accidental spill of fuel (gasoline or diesel) or oil (hydraulic, or motor). The procedures outlined in this SOP are applicable to all personnel working on Aura at Crossroads. Clean up and proper disposal of spilled fuel or oil into the soil or onto the ground surface is required to ensure the material or contaminated soil do not enter or impact the waters of the state or the sanitary sewer system.

B. Summary of the Method

This procedure outlines the steps to be taken to prevent spilled fuel or oil from impacting waters of the state and disposal of the resulting contaminated cleanup material.

C. Definitions

1. Material Safety Data Sheet (MSDS). The standard industry list for a product detailing the chemical make-up, safety hazards, first aid, fire fighting, and spill cleanup measures, handling, storage, and disposal methods

D. Health and Safety Warnings

Fuels and fuel oils may be extremely flammable, cause skin and eye irritation, and may be harmful or fatal if swallowed. Caution should be used during clean up operations. The MSDS for the spilled material should be consulted to ensure personnel safety during cleanup operations.

E. Equipment and Supplies

1. Absorbent pads and booms
2. Hand equipment (shovels, brooms)
3. Waste containers (5 gallon buckets, drums)
4. Personal Protective Equipment

F. Procedural Steps

1. Shut down all equipment operating in the area to prevent ignition of the spill.
2. Contact the Responsible Person on site to enact the emergency response contact procedure.
 - a. The Responsible Person begins contacting Emergency Response Agencies.
 1. For gasoline or diesel spill call 911 for fire control
 - b. Responsible Person shall consult the MSDS for proper spill procedures and determination of Reportable Quantity for a spill.

In the event the spilled quantity exceeds the reportable quantity the Responsible Person shall contact:

1. Call 911 for fire control if necessary.
 2. Colorado Environmental Release and Incident Reporting Hotline (1-877-518-5608)
 3. El Paso County Dispatch: (719) 520-6460
- c. A release of any chemical, oil, petroleum product, sewage, etc., which may enter waters of the State of Colorado (which include surface water, ground water, and dry gullies or storm sewers leading to surface water) must be reported to CDPHE immediately (25-8-601 CRS).
3. Attempt to control the spill by stopping or securing the spill source. This could be as simple as up-righting a tipped container or shutting down a piece of equipment producing the spill.
 4. Prevent migration of the spill by using an absorbent. This could include absorbent pads or booms, floor dry, cat litter, or dirt. The absorbent should be spread across the spill and along the downhill side to stop any flow.
 5. If necessary to prevent the material from entering a storm inlet or manhole a dam of absorbent material should be placed in the gutter upstream from the inlet.
 6. Begin cleanup of the spilled material and absorbents by placing the materials in 5 gallon, plastic buckets with lids or into a provided drum.
 7. Continue cleanup until all spilled material and contaminated absorbents are removed. On a hard surface, this should include sweeping of the area. Material spilled on dirt should be removed down to a level where discoloration of the soil has been removed. Water shall never be used to flush material off a surface.
 8. All material shall be properly stored in a location designated by the Responsible Person on site.
 9. The Responsible Person shall contact the Site Contracted Emergency Response and Disposal Co. to collect and properly dispose of the material.
 10. Location of the spill will be documented on the Stormwater Maintenance Plan (SWMP) in the construction trailer.
 11. Inspection of materials and equipment shall occur daily.

G. Record Management

All documentation from the incident, including incident report and incident disposal manifests, shall be maintained at Trinsic Acquisition Company LLC, 8235 Douglas Avenue, Suite 950, Dallas, TX Ph: (970) 819-9968, for a period of 3 years from the date of the spill.

H. After Incident Briefing

All personnel involved in the incident shall attend a debriefing to determine the cause of the spill, procedures followed, and corrective actions to prevent future spills. All pertinent data will be recorded. The CDPHE shall be notified of a major

spill by a written follow up within five days of the incident. All findings from the debriefing should be discussed at the next Safety Meeting. County of El Paso shall be notified. County of El Paso will require one copy of any documents that are sent to the state.

Standard Operating Procedure (SOP)

Significant Fuel or Oil Spill (25 Gallons or More)

A. Purpose

The purpose of this Standard Operating Procedure is to establish a uniform procedure for clean up and disposal of material from a significant accidental spill of fuel (gasoline or diesel) or oil (hydraulic or motor). The procedures outlined in this SOP are applicable to all personnel working on Aura at Crossroads construction site. Clean up and proper disposal of spilled fuel or oil into the soil or onto the ground surface is required to ensure the material or contaminated soil does not enter or impact the waters of the state or the sanitary sewer system.

B. Summary of the Method

This procedure outlines the steps to be taken to prevent spilled fuel or oil from impacting waters of the state and disposal of the resulting contaminated cleanup material.

C. Definitions

1. Material Safety Data Sheet (MSDS). The standard industry list for a product detailing the chemical make-up, safety hazards, first aid, fire fighting, and spill cleanup measures, handling, storage, and disposal methods

D. Health and Safety Warnings

Fuels and fuel oils may be extremely flammable, cause skin and eye irritation, and may be harmful or fatal if swallowed. Caution should be used during clean up operations. The MSDS for the spilled material should be consulted to ensure personnel safety during cleanup operations.

E. Equipment and Supplies

1. Absorbent pads and booms
2. Hand equipment (shovels, brooms)
3. Waste containers (5 gallon buckets, drums)
4. Personal Protective Equipment

F. Procedural Steps

1. Shut down all equipment operating in the area to prevent ignition of the spill.
2. Ensure the safety of personnel in the area. If necessary, evacuate the area and wait for Emergency Response Personnel.
3. Contact the Chain of Command on site to enact the emergency response contact procedure.
 - a. Responsible Person begins contacting Emergency Response Agencies.
 1. Call 911 for fire control

2. Colorado Environmental Release and Incident Reporting Hotline (1-877-518-5608)
3. El Paso County Dispatch: (719) 520-6460
 - b. Responsible Person consults the MSDS for spill procedure
4. If it can be safely accomplished, attempt to control the spill by stopping or securing the spill source.
5. If it can be safely accomplished, attempt to prevent migration of the spill by using an absorbent. This could include absorbent pads or booms, floor dry, cat litter, or dirt. The absorbent should be spread along the downhill side to stop any flow.
6. If it can be safely accomplished, attempt to prevent the material from entering a storm inlet or manhole by constructing a dam of absorbent material in the gutter upstream from the inlet.
7. Emergency Response Personnel should handle stabilization of the spill and initial cleanup.
8. Final cleanup and disposal of contaminated material should be handled by the Site Contracted Emergency Response and Disposal Co.
9. Location of the spill will be documented on the Stormwater Maintenance Plan (SWMP) in the construction trailer.
10. Inspection of materials and equipment shall occur daily.

G. Record Management

All documentation from the incident, including incident report and incident disposal manifests, shall be maintained at Trinsic Acquisition Company LLC, 8235 Douglas Avenue, Suite 950, Dallas, TX Ph: (970) 819-9968, for a period of 3 years from the date of the spill.

H. After Incident Briefing

All personnel involved in the incident shall attend a debriefing to determine the cause of the spill, procedures followed, and corrective actions to prevent future spills. All pertinent data will be recorded. The CDPHE shall be notified of a major spill by a written follow up within five days of the incident. All findings from the debriefing should be discussed at the next Safety Meeting. El Paso County shall be notified. El Paso County will require one copy of any documents that are sent to the state.

APPENDIX D – Erosion Control Plan

NO CHANGES ARE TO BE MADE TO THIS DRAWING WITHOUT WRITTEN PERMISSION OF HARRIS KOCHER SMITH.

Filepath: K:\210829\ENGINEERING\EROSION\GCS - COVER.DWG, Layout: LAYOUT1
Plotted: TUE 11/02/21 12:34:09 PM By: Ethan Hicks

LEGAL DESCRIPTION:

A PARCEL OF LAND BEING A PORTION OF TRACT B, 2494 BUSINESS PARK FILING NO. 1 RECORDED AT RECEPTION NO. 217713939, AND AMENDED BY SURVEYOR'S AFFIDAVIT OF CORRECTION RECORDED AT RECEPTION NO. 219097386, BOTH OF THE RECORDS OF THE CLERK AND RECORDER OF EL PASO COUNTY, SITUATED IN THE SOUTHWEST QUARTER OF SECTION 8, TOWNSHIP 14 SOUTH, RANGE 65 WEST OF THE SIXTH PRINCIPAL MERIDIAN, COUNTY OF EL PASO, STATE OF COLORADO, MORE PARTICULARLY DESCRIBED AS FOLLOWS:

BEGINNING AT THE NORTHWEST CORNER OF SAID TRACT B;
THENCE NORTH 89°43'03" EAST ALONG THE NORTH LINE OF SAID TRACT B, A DISTANCE OF 600.90 FEET;
THENCE SOUTH 00°07'03" WEST, A DISTANCE OF 643.95 FEET;
THENCE SOUTH 57°41'24" WEST, A DISTANCE OF 69.42 FEET;
THENCE SOUTH 90°00'00" WEST, A DISTANCE OF 600.64 FEET TO THE WEST LINE OF SAID TRACT B;
THENCE NORTH 03°59'08" EAST ALONG SAID WEST LINE, A DISTANCE OF 880.15 FEET TO THE POINT OF BEGINNING;

SAID PARCEL CONTAINS 553,058 SQUARE FEET OR 12.70 ACRES, MORE OR LESS.

BASIS OF BEARINGS:

BEARINGS ARE BASED ON THE WEST LINE OF THE SOUTHWEST QUARTER OF SECTION 8, TOWNSHIP 14 SOUTH, RANGE 68 WEST OF THE 6TH PRINCIPAL MERIDIAN, MONUMENTED AT THE WEST QUARTER CORNER BY AN ILLEGIBLE 3-1/2" BRASS CAP 2.0" DOWN AND AT THE SOUTHWEST CORNER BY A 3-1/2" ALUMINUM CAP IN A RANGE BOX STAMPED "L.S. 22573" ASSUMED TO BEAR NORTH 00°04'51" EAST.

EL PASO COUNTY STANDARD GRADING AND EROSION CONTROL NOTES

- 1. STORMWATER DISCHARGES FROM CONSTRUCTION SITES SHALL NOT CAUSE OR THREATEN TO CAUSE POLLUTION, CONTAMINATION, OR DEGRADATION OF STATE WATERS. ALL WORK AND EARTH DISTURBANCE SHALL BE DONE IN A MANNER THAT MINIMIZES POLLUTION OF ANY ON-SITE OR OFF-SITE WATERS, INCLUDING WETLANDS.
- 2. NOTWITHSTANDING ANYTHING DEPICTED IN THESE PLANS IN WORDS OR GRAPHIC REPRESENTATION, ALL DESIGN AND CONSTRUCTION RELATED TO ROADS, STORM DRAINAGE AND EROSION CONTROL SHALL CONFORM TO THE STANDARDS AND REQUIREMENTS OF THE MOST RECENT VERSION OF THE RELEVANT ADOPTED EL PASO COUNTY STANDARDS, INCLUDING THE LAND DEVELOPMENT CODE, THE ENGINEERING CRITERIA MANUAL, THE DRAINAGE CRITERIA MANUAL, AND THE DRAINAGE CRITERIA MANUAL VOLUME 2. ANY DEVIATIONS FROM REGULATIONS AND STANDARDS MUST BE REQUESTED AND APPROVED, IN WRITING.
- 3. A SEPARATE STORMWATER MANAGEMENT PLAN (SWMP) FOR THIS PROJECT SHALL BE COMPLETED AND AN EROSION AND STORMWATER QUALITY CONTROL PERMIT (ESQCP) ISSUED PRIOR TO COMMENCING CONSTRUCTION. MANAGEMENT OF THE SWMP DURING CONSTRUCTION IS THE RESPONSIBILITY OF THE DESIGNATED QUALIFIED STORMWATER MANAGER OR CERTIFIED EROSION CONTROL INSPECTOR. THE SWMP SHALL BE LOCATED ON SITE AT ALL TIMES DURING CONSTRUCTION AND SHALL BE KEPT UP TO DATE WITH WORK PROGRESS AND CHANGES IN THE FIELD.
- 4. ONCE THE ESQCP IS APPROVED AND A "NOTICE TO PROCEED" HAS BEEN ISSUED, THE CONTRACTOR MAY INSTALL THE INITIAL STAGE EROSION AND SEDIMENT CONTROL MEASURES AS INDICATED ON THE APPROVED GEC. A PRECONSTRUCTION MEETING BETWEEN THE CONTRACTOR, ENGINEER, AND EL PASO COUNTY WILL BE HELD PRIOR TO ANY CONSTRUCTION. IT IS THE RESPONSIBILITY OF THE APPLICANT TO COORDINATE THE MEETING TIME AND PLACE WITH COUNTY STAFF.
- 5. CONTROL MEASURES MUST BE INSTALLED PRIOR TO COMMENCEMENT OF ACTIVITIES THAT COULD CONTRIBUTE POLLUTANTS TO STORMWATER. CONTROL MEASURES FOR ALL SLOPES, CHANNELS, DITCHES, AND DISTURBED LAND AREAS SHALL BE INSTALLED IMMEDIATELY UPON COMPLETION OF THE DISTURBANCE.
- 6. ALL TEMPORARY SEDIMENT AND EROSION CONTROL MEASURES SHALL BE MAINTAINED AND REMAIN IN EFFECTIVE OPERATING CONDITION UNTIL PERMANENT SOIL EROSION CONTROL MEASURES ARE IMPLEMENTED AND FINAL STABILIZATION IS ESTABLISHED. ALL PERSONS ENGAGED IN LAND DISTURBANCE ACTIVITIES SHALL ASSESS THE ADEQUACY OF CONTROL MEASURES AT THE SITE AND IDENTIFY IF CHANGES TO THOSE CONTROL MEASURES ARE NEEDED TO ENSURE THE CONTINUED EFFECTIVE PERFORMANCE OF THE CONTROL MEASURES. ALL CHANGES TO TEMPORARY SEDIMENT AND EROSION CONTROL MEASURES MUST BE INCORPORATED INTO THE STORMWATER MANAGEMENT PLAN.
- 7. TEMPORARY STABILIZATION SHALL BE IMPLEMENTED ON DISTURBED AREAS AND STOCKPILES WHERE GROUND DISTURBING CONSTRUCTION ACTIVITY HAS PERMANENTLY CEASED OR TEMPORARILY CEASED FOR LONGER THAN 14 DAYS.
- 8. FINAL STABILIZATION MUST BE IMPLEMENTED AT ALL APPLICABLE CONSTRUCTION SITES. FINAL STABILIZATION IS ACHIEVED WHEN ALL GROUND DISTURBING ACTIVITIES ARE COMPLETE AND ALL DISTURBED AREAS EITHER HAVE A UNIFORM VEGETATIVE COVER WITH INDIVIDUAL PLANT DENSITY OF 70 PERCENT OF PRE-DISTURBANCE LEVELS ESTABLISHED OR EQUIVALENT PERMANENT ALTERNATIVE STABILIZATION METHOD IS IMPLEMENTED. ALL TEMPORARY SEDIMENT AND EROSION CONTROL MEASURES SHALL BE REMOVED UPON FINAL STABILIZATION AND BEFORE PERMIT CLOSURE.
- 9. ALL PERMANENT STORMWATER MANAGEMENT FACILITIES SHALL BE INSTALLED AS DESIGNED IN THE APPROVED PLANS. ANY PROPOSED CHANGES THAT EFFECT THE DESIGN OR FUNCTION OF PERMANENT STORMWATER MANAGEMENT STRUCTURES MUST BE APPROVED BY THE EGM ADMINISTRATOR PRIOR TO IMPLEMENTATION.
- 10. EARTH DISTURBANCES SHALL BE CONDUCTED IN SUCH A MANNER SO AS TO EFFECTIVELY MINIMIZE ACCELERATED SOIL EROSION AND RESULTING SEDIMENTATION. ALL DISTURBANCES SHALL BE DESIGNED, CONSTRUCTED, AND COMPLETED SO THAT THE EXPOSED AREA OF ANY DISTURBED LAND SHALL BE LIMITED TO THE SHORTEST PRACTICAL PERIOD OF TIME. PRE-EXISTING VEGETATION SHALL BE PROTECTED AND MAINTAINED WITHIN 50 HORIZONTAL FEET OF A WATERS OF THE STATE UNLESS SHOWN TO BE INFEASIBLE AND SPECIFICALLY REQUESTED AND APPROVED.
- 11. COMPACTION OF SOIL MUST BE PREVENTED IN AREAS DESIGNATED FOR INFILTRATION CONTROL MEASURES OR WHERE FINAL STABILIZATION WILL BE ACHIEVED BY VEGETATIVE COVER. AREAS DESIGNATED FOR INFILTRATION CONTROL MEASURES SHALL ALSO BE PROTECTED FROM SEDIMENTATION DURING CONSTRUCTION UNTIL FINAL STABILIZATION IS ACHIEVED. IF COMPACTION PREVENTION IS NOT FEASIBLE DUE TO SITE CONSTRAINTS, ALL AREAS DESIGNATED FOR INFILTRATION AND VEGETATION CONTROL MEASURES MUST BE LOOSENEED PRIOR TO INSTALLATION OF THE CONTROL MEASURES(S).
- 12. ANY TEMPORARY OR PERMANENT FACILITY DESIGNED AND CONSTRUCTED FOR THE CONVEYANCE OF STORMWATER AROUND, THROUGH, OR FROM THE EARTH DISTURBANCE AREA SHALL BE A STABILIZED CONVEYANCE DESIGNED TO MINIMIZE EROSION AND THE DISCHARGE OF SEDIMENT OFF SITE.
- 13. CONCRETE WASH WATER SHALL BE CONTAINED AND DISPOSED OF IN ACCORDANCE WITH THE SWMP. NO WASH WATER SHALL BE DISCHARGED TO OR ALLOWED TO ENTER STATE WATERS, INCLUDING ANY SURFACE OR SUBSURFACE STORM DRAINAGE SYSTEM OR FACILITIES. CONCRETE WASHOUTS SHALL NOT BE LOCATED IN AN AREA WHERE SHALLOW GROUNDWATER MAY BE PRESENT, OR WITHIN 50 FEET OF A SURFACE WATER BODY, CREEK OR STREAM.
- 14. DURING DEWATERING OPERATIONS OF UNCONTAMINATED GROUND WATER MAY BE DISCHARGED ON SITE, BUT SHALL NOT LEAVE THE SITE IN THE FORM OF SURFACE RUNOFF UNLESS AN APPROVED STATE DEWATERING PERMIT IS IN PLACE.
- 15. EROSION CONTROL BLANKETING OR OTHER PROTECTIVE COVERING SHALL BE USED ON SLOPES STEEPER THAN 3:1.
- 16. CONTRACTOR SHALL BE RESPONSIBLE FOR THE REMOVAL OF ALL WASTES FROM THE CONSTRUCTION SITE FOR DISPOSAL IN ACCORDANCE WITH LOCAL AND STATE REGULATORY REQUIREMENTS. NO CONSTRUCTION DEBRIS, TREE SLASH, BUILDING MATERIAL WASTES OR UNUSED BUILDING MATERIALS SHALL BE BURIED, DUMPED, OR DISCHARGED AT THE SITE.
- 17. WASTE MATERIALS SHALL NOT BE TEMPORARILY PLACED OR STORED IN THE STREET, ALLEY, OR OTHER PUBLIC WAY, UNLESS IN ACCORDANCE WITH AN APPROVED TRAFFIC CONTROL PLAN. CONTROL MEASURES MAY BE REQUIRED BY EL PASO COUNTY ENGINEERING IF DEEMED NECESSARY, BASED ON SPECIFIC CONDITIONS AND CIRCUMSTANCES.
- 18. TRACKING OF SOILS AND CONSTRUCTION DEBRIS OFF-SITE SHALL BE MINIMIZED. MATERIALS TRACKED OFF-SITE SHALL BE CLEANED UP AND PROPERLY DISPOSED OF IMMEDIATELY.
- 19. THE OWNER/DEVELOPER SHALL BE RESPONSIBLE FOR THE REMOVAL OF ALL CONSTRUCTION DEBRIS, DIRT, TRASH, ROCK, SEDIMENT, SOIL, AND SAND THAT MAY ACCUMULATE IN ROADS, STORM DRAINS AND OTHER DRAINAGE CONVEYANCE SYSTEMS AND STORMWATER APPURTENANCES AS A RESULT OF SITE DEVELOPMENT.
- 20. THE QUANTITY OF MATERIALS STORED ON THE PROJECT SITE SHALL BE LIMITED, AS MUCH AS PRACTICAL, TO THAT QUANTITY REQUIRED TO PERFORM THE WORK IN AN ORDERLY SEQUENCE. ALL MATERIALS STORED ON-SITE SHALL BE STORED IN A NEAT, ORDERLY MANNER, IN THEIR ORIGINAL CONTAINERS, WITH ORIGINAL MANUFACTURER'S LABELS.
- 21. NO CHEMICAL(S) HAVING THE POTENTIAL TO BE RELEASED IN STORMWATER ARE TO BE STORED OR USED ON-SITE UNLESS PERMISSION FOR THE USE OF SUCH CHEMICAL(S) IS GRANTED IN WRITING BY THE EGM ADMINISTRATOR. IN GRANTING APPROVAL FOR THE USE OF SUCH CHEMICAL(S), SPECIAL CONDITIONS AND MONITORING MAY BE REQUIRED.
- 22. BULK STORAGE OF ALLOWED PETROLEUM PRODUCTS OR OTHER ALLOWED LIQUID CHEMICALS IN EXCESS OF 55 GALLONS SHALL REQUIRE ADEQUATE SECONDARY CONTAINMENT PROTECTION TO CONTAIN ALL SPILLS ON-SITE AND TO PREVENT ANY SPILLED MATERIALS FROM ENTERING STATE WATERS. ANY SURFACE OR SUBSURFACE STORM DRAINAGE SYSTEM OR OTHER FACILITIES.
- 23. NO PERSON SHALL CAUSE THE IMPEDIMENT OF STORMWATER FLOW IN THE CURB AND GUTTER OR DITCH EXCEPT WITH APPROVED SEDIMENT CONTROL MEASURES.
- 24. OWNER/DEVELOPER AND THEIR AGENTS SHALL COMPLY WITH THE "COLORADO WATER QUALITY CONTROL ACT" (TITLE 25, ARTICLE 8, CRS), AND THE "CLEAN WATER ACT" (33 USC 1344), IN ADDITION TO THE REQUIREMENTS OF THE LAND DEVELOPMENT CODE, DDM VOLUME II AND THE EGM APPENDIX I. ALL APPROPRIATE PERMITS MUST BE OBTAINED BY THE CONTRACTOR PRIOR TO CONSTRUCTION (1041, NPDES, FLOODPLAIN, 404, FUGITIVE DUST, ETC.), IN THE EVENT OF CONFLICTS BETWEEN THESE REQUIREMENTS AND OTHER LAWS, RULES, OR REGULATIONS OF OTHER FEDERAL, STATE, LOCAL, OR COUNTY AGENCIES, THE MOST RESTRICTIVE LAWS, RULES, OR REGULATIONS SHALL APPLY.
- 25. ALL CONSTRUCTION TRAFFIC MUST ENTER/EXIT THE SITE ONLY AT APPROVED CONSTRUCTION ACCESS POINTS.
- 26. PRIOR TO CONSTRUCTION THE PERMITTEE SHALL VERIFY THE LOCATION OF EXISTING UTILITIES.
- 27. A WATER SOURCE SHALL BE AVAILABLE ON SITE DURING EARTHWORK OPERATIONS AND SHALL BE UTILIZED AS REQUIRED TO MINIMIZE DUST FROM EARTHWORK EQUIPMENT AND WIND.
- 28. THE SOILS REPORT FOR THIS SITE HAS BEEN PREPARED BY CTL THOMPSON ON MAY 19, 2021 AND SHALL BE CONSIDERED A PART OF THESE PLANS.
- 29. AT LEAST TEN (10) DAYS PRIOR TO THE ANTICIPATED START OF CONSTRUCTION, FOR PROJECTS THAT WILL DISTURB ONE (1) ACRE OR MORE, THE OWNER OR OPERATOR OF CONSTRUCTION ACTIVITY SHALL SUBMIT A PERMIT APPLICATION FOR STORMWATER DISCHARGE TO THE COLORADO DEPARTMENT OF PUBLIC HEALTH AND ENVIRONMENT, WATER QUALITY DIVISION. THE APPLICATION CONTAINS CERTIFICATION OF COMPLETION OF A STORMWATER MANAGEMENT PLAN (SWMP), OF WHICH THIS GRADING AND EROSION CONTROL PLAN MAY BE A PART. FOR INFORMATION OR APPLICATION MATERIALS CONTACT:

COLORADO DEPARTMENT OF PUBLIC HEALTH AND ENVIRONMENT
WATER QUALITY CONTROL DIVISION
WQCD - PERMITS
4300 CHERRY CREEK DRIVE SOUTH
DENVER, CO 80246-1530
ATTN: PERMITS UNIT

AURA AT CROSSROADS

SITUATED IN THE SOUTHEAST 1/4 OF SECTION 8, TOWNSHIP 14 SOUTH, RANGE 65 WEST OF THE 6TH P.M., COUNTY OF EL PASO, STATE OF COLORADO

GRADING AND EROSION CONTROL PLANS

ABBREVIATIONS

BOP	BOTTOM OF PIPE
BS	BOTTOM OF STEP
BW	BOTTOM OF WALL (FG)
CONC	CONCRETE
DIA	DIAMETER
DIP	DUCTILE IRON PIPE
DR	DOOR
DS	DOWNSPROUT
E	EAST, EASTING
EGL	ENERGY GRADE LINE
EL	ELEVATION
EA	EDGE OF ASPHALT
EOC	EDGE OF CONCRETE
EOP	EDGE OF PAVEMENT
ESMT	EASEMENT
EX	EXISTING
FES	FLARED END SECTION
FF	FINISHED FLOOR
FG	FINISHED GRADE
FH	FIRE HYDRANT
FUTR	FUTURE
F	FLOW LINE
GB	GRADE BREAK
GV	GATE VALVE
HC	HANDICAP
HGL	HYDRAULIC GRADE LINE
HORZ	HORIZONTAL
HP	HIGH POINT
INV	INVERT
LF	LINEAR FEET
LSD	LANDSCAPE DRAIN
MAX	MAXIMUM
MH	MANHOLE
MIN	MINIMUM
MJ	MECHANICAL JOINT
N	NORTH, NORTHING
PHS	PHASE
PR	PROPOSED
PVC	POLYVINYL CHLORIDE
RCP	REINFORCED CONCRETE PIPE
ROW	RIGHT-OF-WAY
SAN	SANITARY
SF	SQUARE FEET
SS	SANITARY SEWER
STA	STATION
STM	STORM
TB	THRUST BLOCK
TBC	TOP/BACK OF CURB
TOP	TOP OF PIPE
TS	TOP OF STEP
TW	TOP OF WALL (FG)
TYP	TYPICAL
UG	UNDERGROUND
VERT	VERTICAL
WAT	WATER

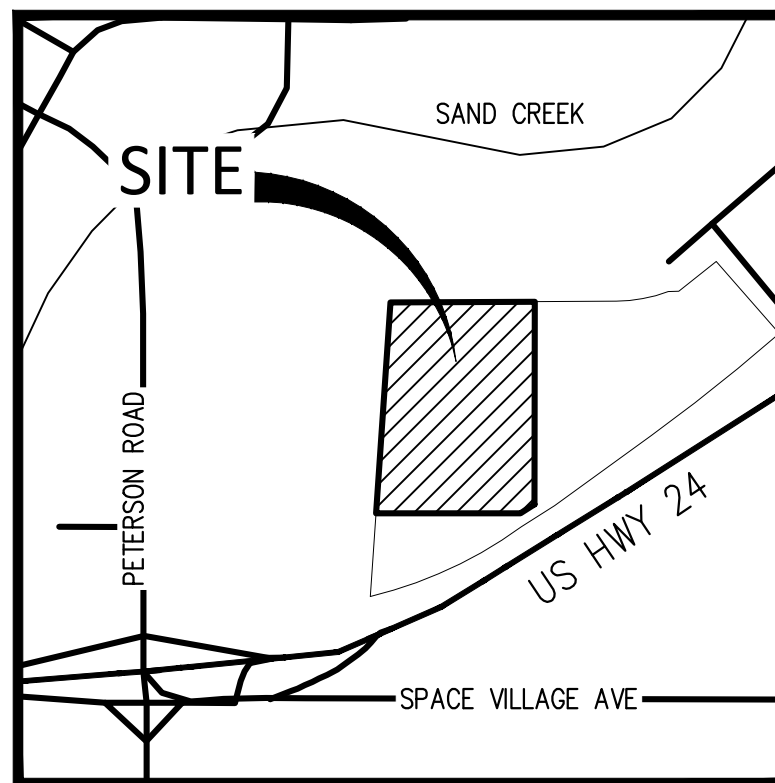

VICINITY MAP
SCALE: 1" = 800'

SHEET INDEX

EC1	GRADING AND EROSION CONTROL COVER
EC2	GRADING AND EROSION CONTROL - INITIAL
EC3	GRADING AND EROSION CONTROL - INTERIM
EC4	GRADING AND EROSION CONTROL - FINAL
EC5	GRADING AND EROSION CONTROL - DETAILS
EC6	GRADING AND EROSION CONTROL - DETAILS

GENERAL STORM NOTES:

- 1. THE CONTRACTOR SHALL NOTIFY COLORADO 811 PRIOR TO EXCAVATION, IN ACCORDANCE WITH COLORADO STATE STATUTES.
- 2. THE LOCATION OF EXISTING UNDERGROUND UTILITIES IS APPROXIMATE AND SHOWN ACCORDING TO THE BEST INFORMATION AVAILABLE, AS SUPPLIED BY THE UTILITY OWNERS. PRIOR TO EXCAVATION, THE CONTRACTOR SHALL VERIFY EXISTENCE, SIZE, AND LOCATION OF EXISTING UTILITIES AND IMMEDIATELY NOTIFY HARRIS KOCHER SMITH OF ANY DISCREPANCIES. THE CONTRACTOR IS RESPONSIBLE FOR ANY AND ALL DAMAGES TO EXISTING UNDERGROUND FACILITIES.
- 3. PIPE LENGTHS ARE MEASURED FROM CENTER OF STRUCTURE TO CENTER OF STRUCTURE FOR CYLINDRICAL MANHOLES AND TO THE INSIDE FACE OF INLETS AND OTHER BOX STRUCTURES. PIPE LENGTHS ARE MEASURED TO THE END OF THE STRUCTURE FOR ALL FLARED END SECTIONS.
- 4. STATIONING OF INLETS SHOWN IN STORM SEWER PROFILES IS AT CENTER OF STRUCTURE.
- 5. ALL COORDINATES ARE AT THE CENTER OF THE STRUCTURE UNLESS OTHERWISE INDICATED.
- 6. CONTRACTOR SHALL USE HDPE, PVC, OR RCP PIPES FOR THE MAIN LINES, BUT SHALL NOTIFY THE JURISDICTIONAL UTILITY PROVIDER AND THE ENGINEER, PRIOR TO INSTALLATION, FOR APPROVAL.
- 7. FOR ALL NON-CONCENTRIC MANHOLES, MANHOLE RINGS/COVERS AND STEPS LIDS SHALL BE ROTATED AS SHOWN IN PLAN VIEW.
- 8. ALL TYPE C & D INLETS SHALL HAVE CLOSE MESH GRATES.
- 9. ALL LATERAL PIPE-TO-PIPE CONNECTIONS SHALL BE MADE USING KOR-A-TEE CONNECTORS OR ENGINEER APPROVED EQUIVALENT.
- 10. CONTRACTOR SHALL ADJUST ALL EXISTING RIM ELEVATIONS TO MATCH THE PROPOSED GRADE.
- 11. CONTRACTOR SHALL MOOPY INLET BASES AS NEEDED IN ORDER TO ENSURE ALL STORM PIPES CONNECT PROPERLY TO THE INLET. CONTRACTOR SHALL PROVIDE SHOP DRAWINGS FOR REVIEW AND APPROVAL BY ENGINEER, OWNER, AND CITY/COUNTY PRIOR TO INSTALLATION.
- 12. CONTRACTOR SHALL PROVIDE ENGINEERED SHOP DRAWINGS, DESIGNED BY A LICENSED ENGINEER, DETAILING THE STRUCTURAL DESIGN OF ALL POND IMPROVEMENTS (FOREBAY, ENERGY DISSIPATING BAFFLES, OUTLET STRUCTURE, ETC.) FOR REVIEW AND APPROVAL BY ENGINEER, OWNER, AND CITY/COUNTY PRIOR TO INSTALLATION.

WATER QUALITY/NPDES EROSION AND SEDIMENT CONTROL NOTES

- 1. THIS CONSTRUCTION ACTIVITIES STORMWATER MANAGEMENT PLAN HAS BEEN SUBMITTED AS THE APPLICATION FOR A STORMWATER PERMIT FOR CONSTRUCTION ACTIVITIES FROM THE WATER QUALITY CONTROL DIVISION OF COLORADO DEPARTMENT OF PUBLIC HEALTH AND ENVIRONMENT. I UNDERSTAND THAT ADDITIONAL EROSION AND SEDIMENT CONTROL MEASURES MAY BE REQUIRED OF THE OWNER AND HIS OR HER AGENTS DUE TO UNFORESEEN EROSION PROBLEMS OR THE SUBMITTED PLAN DOES NOT FUNCTION AS INTENDED. THE REQUIREMENTS OF THIS PLAN SHALL BE THE OBLIGATION OF THE LAND OWNER AND/OR HIS SUCCESSORS OR HEIRS, UNTIL SUCH TIME AS THE PLAN IS PROPERLY COMPLETED, MODIFIED, OR VOIDED.
- 2. THE CONTRACTOR SHALL LOCATE, INSTALL, AND MAINTAIN ALL EROSION CONTROL AND WATER QUALITY "BEST MANAGEMENT PRACTICES" AS INDICATED IN THE APPROVED CONSTRUCTION ACTIVITIES STORMWATER MANAGEMENT PLAN AND GEC PLANS.
- 3. MODIFICATION OF AN ACTIVE STORMWATER PERMIT FOR CONSTRUCTION ACTIVITIES BY THE DEVELOPER, CONTRACTOR, OR THEIR AUTHORIZED AGENTS SHALL REQUIRE TIMELY NOTIFICATION OF AND APPROVAL BY THE WATER QUALITY CONTROL DIVISION. TERMINATION OF AN ACTIVE STORMWATER PERMIT FOR CONSTRUCTION ACTIVITIES UPON COMPLETION OF THE PROJECT REQUIRES NOTIFICATION OF AND APPROVAL BY EL PASO COUNTY ENGINEERING.

BMP MAINTENANCE NOTE

ALL EROSION AND SEDIMENT CONTROL PRACTICES AND OTHER PROTECTIVE MEASURES IDENTIFIED IN THE SWMP MUST BE MAINTAINED IN EFFECTIVE OPERATING CONDITION. PROPER SELECTION AND INSTALLATION OF BMPs AND IMPLEMENTATION OF COMPREHENSIVE INSPECTION AND MAINTENANCE PROCEDURES, IN ACCORDANCE WITH THE SWMP, SHOULD BE ADEQUATE TO MEET THIS CONDITION. BMPs THAT ARE NOT ADEQUATELY MAINTAINED IN ACCORDANCE WITH GOOD ENGINEERING, HYDROLOGIC AND POLLUTION CONTROL PRACTICES, INCLUDING REMOVAL OF COLLECTED SEDIMENT OUTSIDE THE ACCEPTABLE TOLERANCES OF THE BMPs, ARE CONSIDERED TO BE NO LONGER OPERATING EFFECTIVELY AND MUST BE ADDRESSED.

UTILITY NOTES

- 1. THE LOCATION OF EXISTING UNDERGROUND UTILITIES ARE SHOWN ACCORDING TO THE BEST INFORMATION AVAILABLE, AS SUPPLIED BY THE UTILITY OWNERS. PRIOR TO EXCAVATION, THE CONTRACTOR SHALL VERIFY EXISTENCE, SIZE AND LOCATION OF EXISTING UTILITIES AND IMMEDIATELY NOTIFY HARRIS KOCHER SMITH OF ANY DISCREPANCIES. THE CONTRACTOR IS RESPONSIBLE FOR ANY AND ALL DAMAGES TO EXISTING UNDERGROUND FACILITIES.
- 2. THE CONTRACTOR SHALL NOTIFY 811 PRIOR TO EXCAVATION, IN ACCORDANCE WITH COLORADO STATE STATUTES.
- 3. CONTRACTOR SHALL BE RESPONSIBLE FOR ALL CONSTRUCTION ACTIVITIES, DEWATERING DISCHARGE, PERMITTING FOR ALL UTILITY INSTALLATION. PUMP RATE TESTS ARE HIGHLY RECOMMENDED.

ENGINEER STATEMENT

THIS GRADING AND EROSION CONTROL PLAN WAS PREPARED UNDER MY DIRECTION AND SUPERVISION AND IS CORRECT TO THE BEST OF MY KNOWLEDGE AND BELIEF. SAID PLAN HAS BEEN PREPARED ACCORDING TO THE CRITERIA ESTABLISHED BY THE COUNTY FOR GRADING AND EROSION CONTROL PLANS. I ACCEPT RESPONSIBILITY FOR ANY LIABILITY CAUSED BY ANY NEGLIGENT ACTS, ERRORS OR OMISSIONS ON MY PART IN PREPARING THIS PLAN.

PRELIMINARY
NOT FOR
CONSTRUCTION

JOHN D. O'ROURKE, P.E. DATE
REGISTERED PROFESSIONAL ENGINEER
STATE OF COLORADO NO. 43327

OWNER CERTIFICATION

I, THE OWNER/DEVELOPER HAVE READ AND WILL COMPLY WITH THE REQUIREMENTS OF THE GRADING AND EROSION CONTROL PLAN.

ALLISON JONES DATE
TRINISC ACQUISITION COMPANY, LLC

EL PASO COUNTY

COUNTY PLAN REVIEW IS PROVIDED ONLY FOR GENERAL CONFORMANCE WITH COUNTY DESIGN CRITERIA. THE COUNTY IS NOT RESPONSIBLE FOR THE ACCURACY AND ADEQUACY OF THE DESIGN, DIMENSIONS, AND/OR ELEVATIONS WHICH SHALL BE CONFIRMED AT THE JOB SITE. THE COUNTY THROUGH THE APPROVAL OF THIS DOCUMENT ASSUMES NO RESPONSIBILITY FOR COMPLETENESS AND/OR ACCURACY OF THIS DOCUMENT. FILED IN ACCORDANCE WITH THE REQUIREMENTS OF THE EL PASO COUNTY LAND DEVELOPMENT CODE, DRAINAGE CRITERIA MANUAL VOLUMES 1 AND 2, AND ENGINEERING CRITERIA MANUAL, AS AMENDED.

IN ACCORDANCE WITH EGM SECTION 1.12, THESE CONSTRUCTION DOCUMENTS WILL BE VALID FOR CONSTRUCTION FOR A PERIOD OF 2 YEARS FROM THE DATE SIGNED BY THE EL PASO COUNTY ENGINEER. IF CONSTRUCTION HAS NOT STARTED WITHIN THOSE 2 YEARS, THE PLANS WILL NEED TO BE RESUBMITTED FOR APPROVAL, INCLUDING PAYMENT OF REVIEW FEES AT THE PLANNING AND COMMUNITY DEVELOPMENT DIRECTOR'S DISCRETION.

JENNIFER IRVINE, PE DATE
COUNTY ENGINEER



Know what's below.
Call before you dig.

DEVELOPER

TRINISC ACQUISITION COMPANY, LLC
8235 DOUGLAS AVENUE, SUITE 950
DALLAS, TX 75225
P: 970.819.9968

CIVIL ENGINEER

HKS HARRIS KOCHER SMITH
1120 Lincoln Street, Suite 1000
Denver, Colorado 80203
P: 303.623.6300 F: 303.623.6311
HarrisKocherSmith.com

ISSUE DATE: 08-06-2021	PROJECT #: 200823
DATE	REVISION COMMENTS
10-29-2021	PER COUNTY COMMENTS

NO CHANGES ARE TO BE MADE TO THIS DRAWING WITHOUT WRITTEN PERMISSION OF HARRIS KOCHER SMITH.

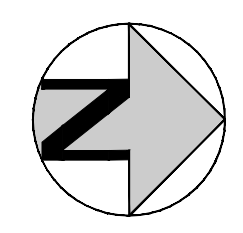
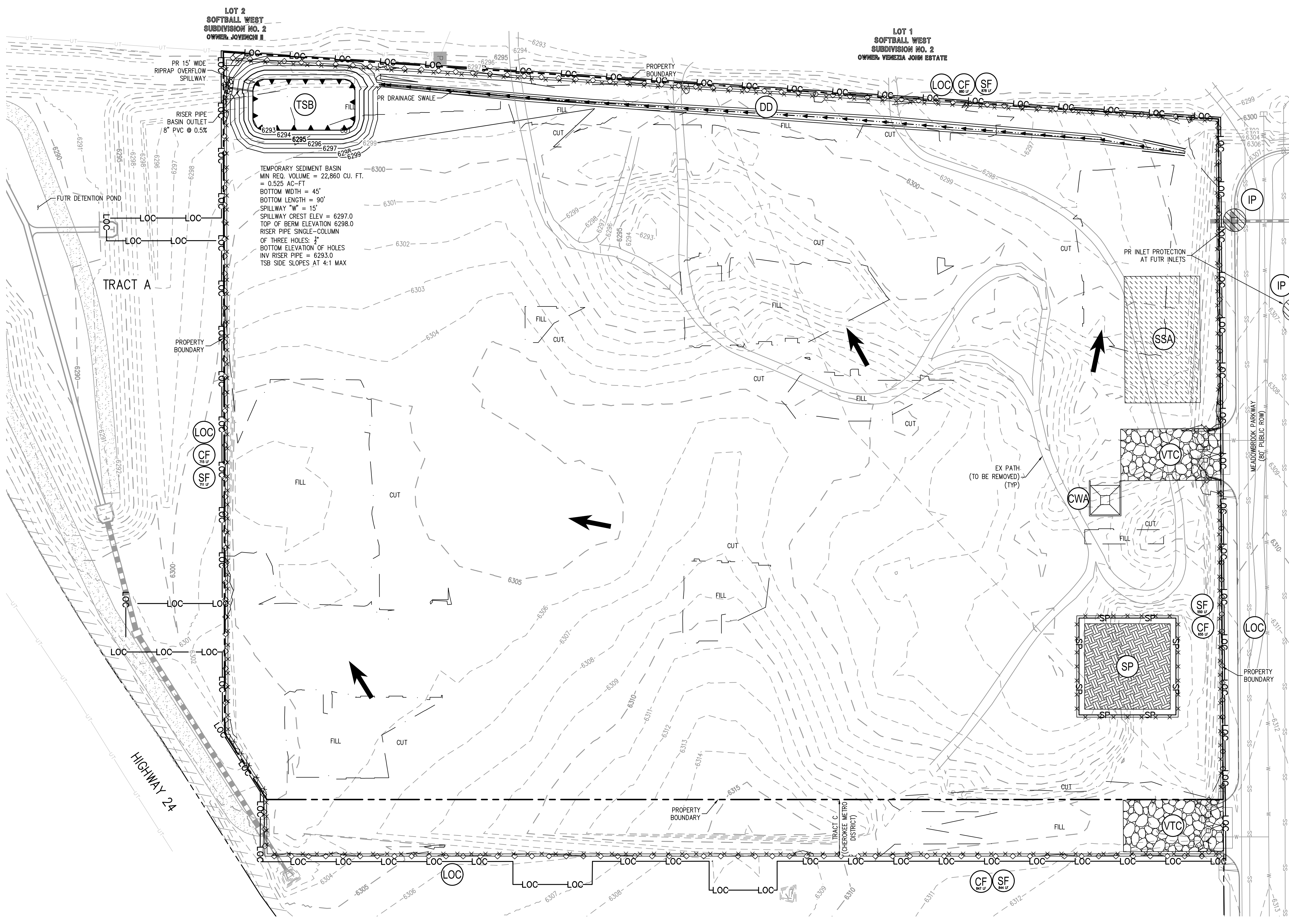

- LEGEND:**
- EXISTING CONTOURS
 - PROPOSED CONTOURS
 - LIMITS OF CONSTRUCTION / LIMITS OF DISTURBANCE
 - CONSTRUCTION FENCE
 - SILT FENCE
 - STABILIZED STAGING AREA
 - DIVERSION DITCH
 - VEHICLE TRACKING CONTROL
 - CONCRETE WASHOUT AREA
 - SOIL STOCKPILE
 - INLET PROTECTION
 - TEMPORARY SEDIMENT BASIN

- LEGEND:**
- PROPERTY BOUNDARY
 - RIGHT-OF-WAY
 - BUILDING EDGE
 - CUT / FILL BOUNDARY

- INITIAL NOTES:**
1. NO NOTABLE EXISTING VEGETATION. LOT WILL BE STRIPPED DURING OVERLOT GRADING COMPLETED PRIOR TO PROJECT COMMENCEMENT.
 2. APPROPRIATE CONTROL MEASURES MUST BE IMPLEMENTED PRIOR TO THE START OF LAND DISTURBANCE ACTIVITY. MUST CONTROL POTENTIAL POLLUTANTS DURING EACH PHASE OF CONSTRUCTION, AND MUST BE CONTINUED THROUGH FINAL STABILIZATION. APPROPRIATE STRUCTURAL AND NON-STRUCTURAL CONTROL MEASURES MUST BE MAINTAINED IN OPERATIONAL CONDITION.
 3. SEE STANDARD NOTES AND DETAILS (SHEET 5-6) FOR LEGEND OF CONTROL MEASURES NAMES AND SYMBOLS.
 4. ANY CONTROL MEASURES SHOWN THAT REQUIRE GRADING, (E.G. SEDIMENT BASINS, SEDIMENTS TRAPS, CONCRETE WASHOUT AREAS, ETC.), SHALL NOT BE PLACED UNTIL AFTER THE PRE-CONSTRUCTION MEETING AND ISSUANCE OF THE GESC PERMIT, BUT MUST BE FULLY FUNCTIONAL PRIOR TO ANY LARGE-SCALE GRADING. THE INITIAL PLAN ILLUSTRATES EXISTING CONDITIONS. NO PROPOSED INFRASTRUCTURE IS SHOWN.
 5. EXISTING VEGETATION CONSISTS OF MOSTLY GRASSES AND WEEDS AND SCATTERED TREES.

FILEPATH: K:\200823\ENGINEERING\GESC - INITIAL DING LAYOUT.LAYOUT
 DWGNO: 200823-01.dwg
 PLOTTED: TUE 11/02/21 12:33:56P BY: ETHAN MAROS

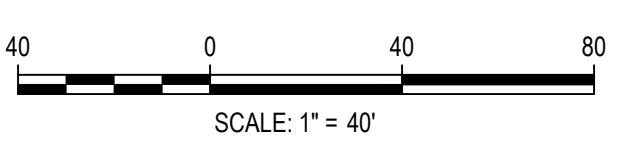

DESIGNED BY: AJH
 CHECKED BY: JDO
 DRAWN BY: AJH

ISSUE DATE: 08-06-2021	
DATE	REVISION COMMENTS
10-29-2021	PER COUNTY COMMENTS

HKS HARRIS KOCHER SMITH
 1120 Lincoln Street, Suite 1000
 Denver, Colorado 80203
 P: 303.623.6300 F: 303.623.6311
 HarrisKocherSmith.com

TRINISIC ACQUISITION COMPANY, LLC

AURA AT CROSSROADS
 GRADING AND EROSION CONTROL - INITIAL

PRELIMINARY
 NOT FOR
 CONSTRUCTION

PROJECT #: 200823
 SHEET NUMBER
EC2
 2 OF 24

NO CHANGES ARE TO BE MADE TO THIS DRAWING WITHOUT WRITTEN PERMISSION OF HARRIS KOCHER SMITH.

LOT 2
SOFTBALL WEST
SUBDIVISION NO. 2
OWNER: JOYEMCHI II

LOT 1
SOFTBALL WEST
SUBDIVISION NO. 2
OWNER: VEREZIA JOHN ESTATE

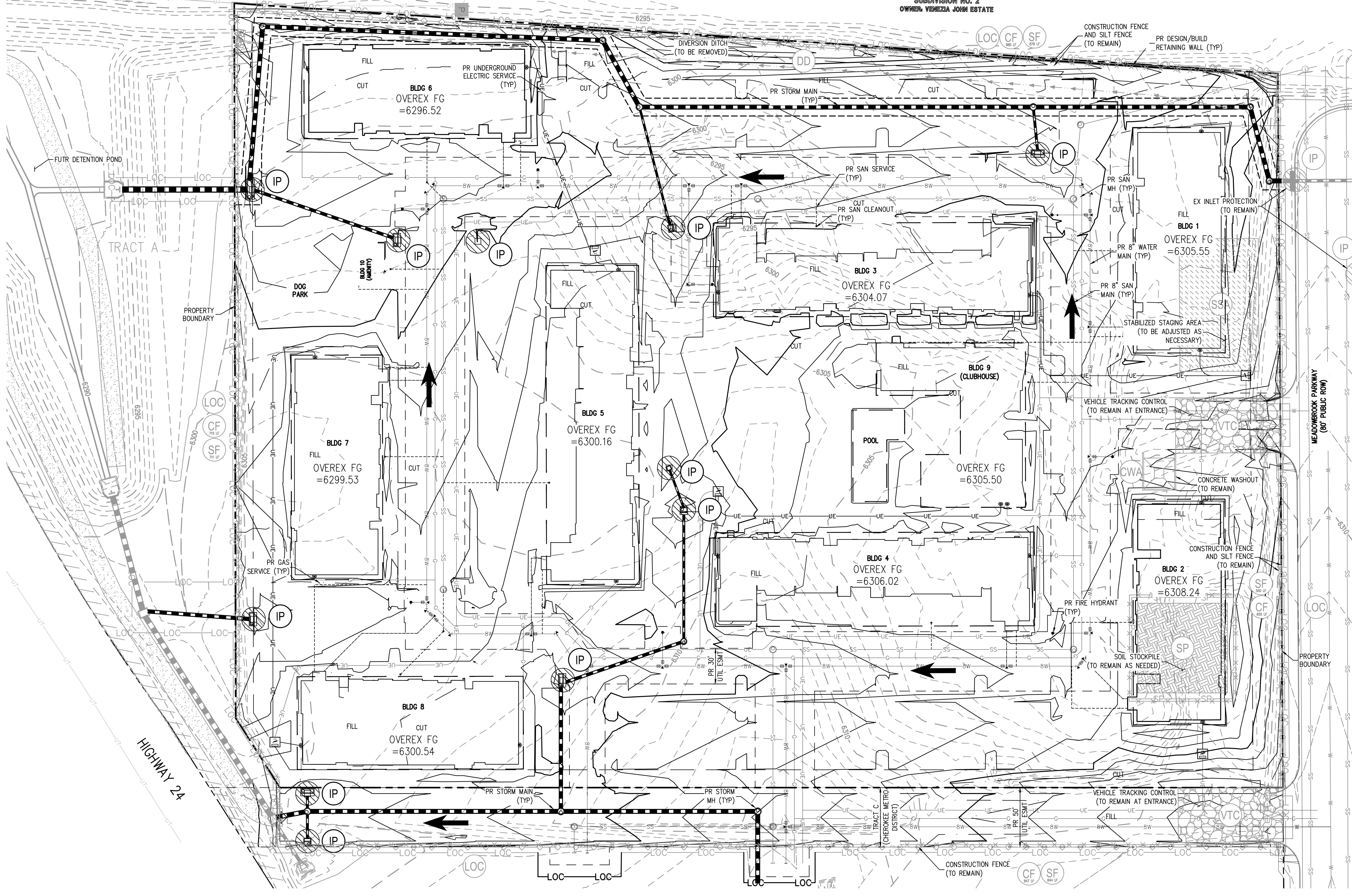
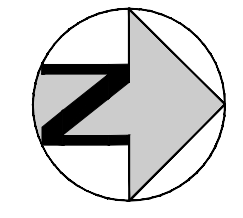

- LEGEND:**
- EXISTING CONTOURS
 - PROPOSED CONTOURS
 - LIMITS OF CONSTRUCTION / LIMITS OF DISTURBANCE
 - CONSTRUCTION FENCE
 - SILT FENCE
 - STABILIZED STAGING AREA
 - DIVERSION DITCH
 - VEHICLE TRACKING CONTROL
 - CONCRETE WASHOUT AREA
 - INLET PROTECTION
 - SOIL STOCKPILE
- LEGEND:**
- PROPERTY BOUNDARY
 - RIGHT-OF-WAY
 - BUILDING EDGE
 - PR STORM SEWER LINE
 - PR SANITARY SEWER W/MANHOLE
 - PR SANITARY SEWER W/CLEAN-OUT
 - PR SANITARY SEWER W/MANHOLE BYOT
 - PR WATER SERVICE RESIDENTIAL LINE
 - PR WATER SERVICE FIRE LINE
 - PR WATER METER
 - PR WATER LINE
 - PR HYDRANT
 - PR GAS MAIN
 - PR GAS SERVICE LINE
 - PR UNDERGROUND ELECTRIC
 - PR TRANSFORMER

- INTERIM NOTES:**
- APPROPRIATE CONTROL MEASURES MUST BE IMPLEMENTED PRIOR TO THE START OF LAND DISTURBANCE ACTIVITY. MUST CONTROL POTENTIAL POLLUTANTS DURING EACH PHASE OF CONSTRUCTION, AND MUST BE CONTINUED THROUGH FINAL STABILIZATION. APPROPRIATE STRUCTURAL AND NON-STRUCTURAL CONTROL MEASURES MUST BE MAINTAINED IN OPERATIONAL CONDITION.
 - SEE STANDARD NOTES AND DETAILS (SHEET 5-6) FOR LEGEND OF CONTROL MEASURES NAMES AND SYMBOLS.
 - SCREENED/SHADED CONTROL MEASURES WERE INSTALLED IN THE INITIAL STAGE AND SHALL BE LEFT IN PLACE IN THE INTERIM STAGE UNLESS OTHERWISE NOTED.
 - CONTROL MEASURES, INCLUDING SEEDING AND MULCHING OF DISTURBED AREAS, MUST BE COMPLETED WITHIN 14 DAYS. IF THE AREA WILL REMAIN UNDISTURBED FOR A PERIOD GREATER THAN 30 DAYS.
 - ALL PROPOSED SLOPES ON THIS PLAN HAVE A MAXIMUM SLOPE OF 3:1. ANY SLOPES BETWEEN 3:1 AND 4:1 WILL REQUIRE THE USE OF EROSION CONTROL BLANKETS OR FLEXIBLE GROWTH MEDIUM, AS APPROVED BY THE GESC INSPECTOR.
 - SEE CONSTRUCTION PLANS FOR DETAILS OF PERMANENT DRAINAGE FACILITIES SUCH AS DETENTION FACILITIES, WATER QUALITY FACILITIES, CULVERTS, STORM DRAINS, AND INLET & OUTLET PROTECTION.
 - IF SITE RUNOFF ENTERS THE POST-CONSTRUCTION PERMANENT CONTROL MEASURE(S), SEDIMENT CONTAMINATION OF THE MATERIALS MAY RESULT IN THE POST-CONSTRUCTION PERMANENT CONTROL MEASURE(S) HAVING TO BE RECONSTRUCTED IN ITS ENTIRETY. REMOVAL OF THE SEDIMENT BASIN ON SITE SHALL ONLY OCCUR AFTER ALL AREAS TRIBUTARY TO THE SEDIMENT BASIN HAVE BEEN STABILIZED, WHERE APPLICABLE. REMOVAL MUST BE APPROVED BY THE GESC INSPECTOR.
 - NO BATCH PLANTS WILL BE UTILIZED ONSITE.

DESIGNED BY: AJH
CHECKED BY: JDO
DRAWN BY: AJH

DATE	REVISION COMMENTS
10-29-2021	PER COUNTY COMMENTS

1120 Lincoln Street, Suite 1000
Denver, Colorado 80203
P: 303.623.6300 F: 303.623.6311
HarrisKocherSmith.com

TRINISIC ACQUISITION COMPANY, LLC

AURA AT CROSSROADS
GRADING AND EROSION CONTROL - INTERIM

PRELIMINARY
NOT FOR
CONSTRUCTION

PROJECT #: 200823
SHEET NUMBER
EC3
3 OF 24

NO CHANGES ARE TO BE MADE TO THIS DRAWING WITHOUT WRITTEN PERMISSION OF HARRIS KOCHER SMITH.

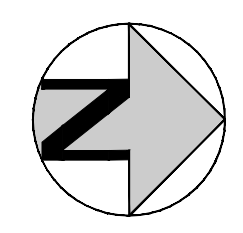
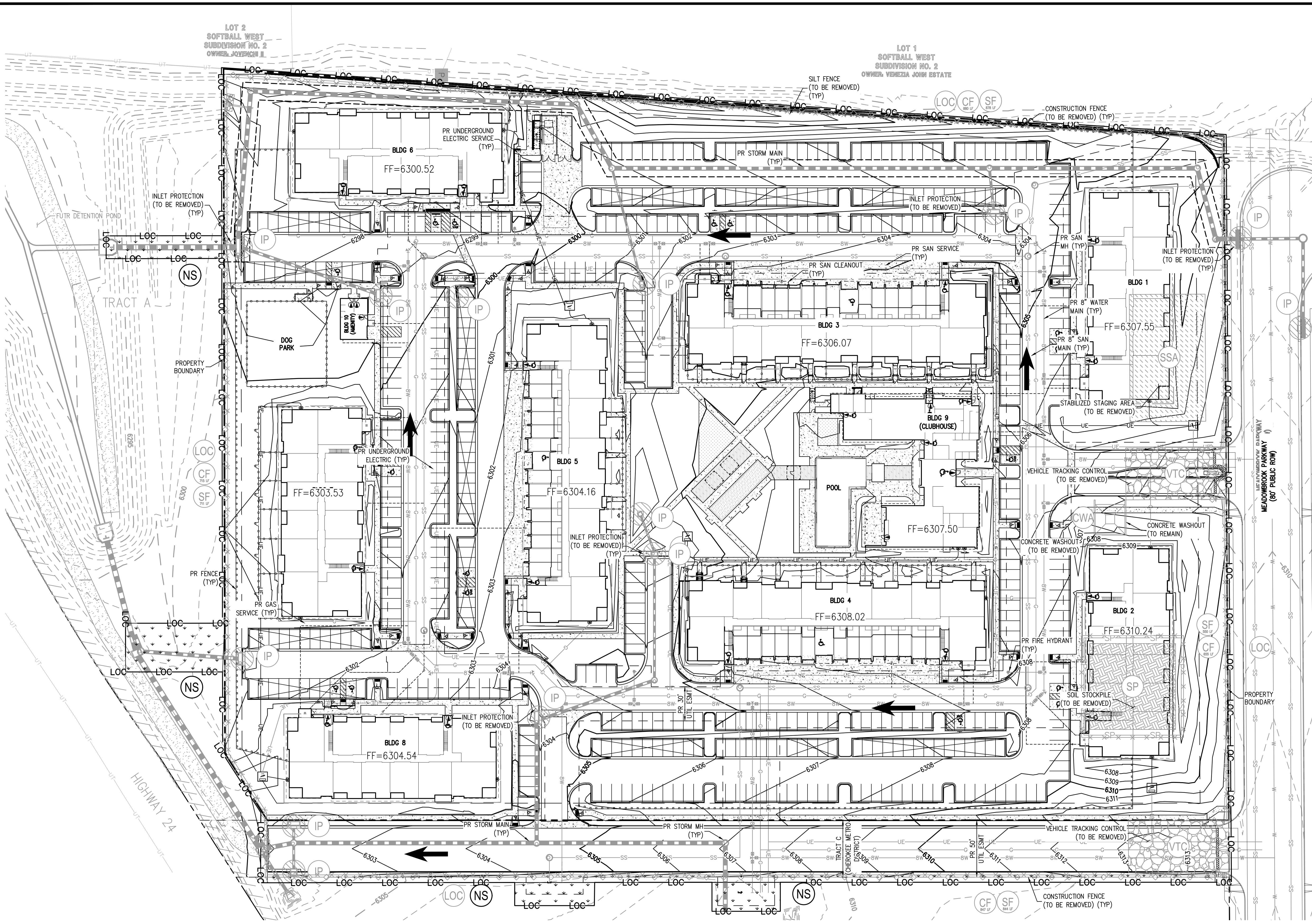

- LEGEND:**
- EXISTING CONTOURS 5321 5320
 - PROPOSED CONTOURS 5173 5170
 - LIMITS OF CONSTRUCTION / LIMITS OF DISTURBANCE LOC
 - CONSTRUCTION FENCE CF
 - SILT FENCE SF
 - STABILIZED STAGING AREA SSA
 - VEHICLE TRACKING CONTROL VTC
 - CONCRETE WASHOUT AREA CWA
 - INLET PROTECTION IP IP
 - NATIVE SEED STABILIZATION NS NS

- LEGEND:**
- PROPERTY BOUNDARY
 - RIGHT-OF-WAY
 - BUILDING EDGE
 - PR STORM SEWER LINE
 - PR SANITARY SEWER W/MANHOLE
 - PR SANITARY SERVICE W/CLEAN-OUT
 - PR SANITARY SEWER W/MANHOLE BYOT
 - PR WATER SERVICE RESIDENTIAL LINE
 - PR WATER SERVICE FIRE LINE
 - PR WATER METER M
 - PR WATER LINE BYOT
 - PR HYDRANT BYOT H
 - PR GAS MAIN
 - PR GAS SERVICE LINE
 - PR UNDERGROUND ELECTRIC
 - PR TRANSFORMER T

- FINAL NOTES:**
1. APPROPRIATE CONTROL MEASURES MUST BE IMPLEMENTED PRIOR TO THE START OF LAND DISTURBANCE ACTIVITY. MUST CONTROL POTENTIAL POLLUTANTS DURING EACH PHASE OF CONSTRUCTION, AND MUST BE CONTINUED THROUGH FINAL STABILIZATION. APPROPRIATE STRUCTURAL AND NON-STRUCTURAL CONTROL MEASURES MUST BE MAINTAINED IN OPERATIONAL CONDITION.
 2. SEE STANDARD NOTES AND DETAILS (SHEET 5 - 7) FOR LEGEND OF CONTROL MEASURES NAMES AND SYMBOLS.
 3. SCREENED/SHADED CONTROL MEASURES WERE INSTALLED IN THE LEFT OR INTERIM STAGE AND, UNLESS OTHERWISE INDICATED, SHALL BE IN PLACE UNTIL APPROVED BY THE GESC INSPECTOR.
 4. ALL INTERIM CONTROL MEASURES, INCLUDING SEEDING AND MULCHING OF DISTURBED AREAS, MUST BE COMPLETED WITHIN 14 DAYS, IF THE AREA WILL REMAIN UNDISTURBED FOR A PERIOD GREATER THAN 30 DAYS.
 5. ALL PROPOSED SLOPES ON THIS PLAN HAVE A MAXIMUM SLOPE OF 3:1. ANY SLOPES BETWEEN 3:1 AND 4:1 WILL REQUIRE THE USE OF EROSION CONTROL BLANKETS OR FLEXIBLE GROWTH MEDIUM, AS APPROVED BY THE GESC INSPECTOR.
 6. SEE CONSTRUCTION PLANS FOR DETAILS OF PERMANENT DRAINAGE FACILITIES SUCH AS DETENTION FACILITIES, WATER QUALITY FACILITIES, CULVERTS, STORM DRAINS, AND INLET AND OUTLET PROTECTION.
 7. ACCEPTANCE OF THE POST-CONSTRUCTION PERMANENT CONTROL MEASURES WILL NOT OCCUR UNTIL ALL TRIBUTARY AREAS TO THE PERMANENT CONTROL MEASURES ARE FULLY STABILIZED.

FILE PATH: K:\200823\ENGINEERING\GESC-FINAL DWG LAYOUT LAYOUT1.rvt
 FILE NAME: gesc-final.dwg
 PLOTTED: TUE 11/02/21 12:34:59P
 PLOTTED BY: ETHAN MARSH

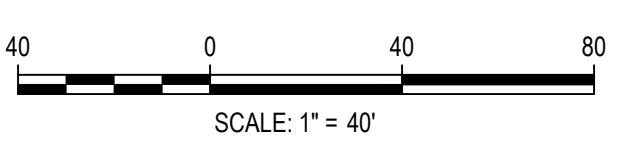

ISSUE DATE: 08-06-2021	
DATE	REVISION COMMENTS
10-29-2021	PER COUNTY COMMENTS

HKS HARRIS KOCHER SMITH
 1120 Lincoln Street, Suite 1000
 Denver, Colorado 80203
 P: 303.623.6300 F: 303.623.6311
 HarrisKocherSmith.com

TRINISIC ACQUISITION COMPANY, LLC

AURA AT CROSSROADS
 GRADING AND EROSION CONTROL - FINAL

PRELIMINARY
 NOT FOR
 CONSTRUCTION

PROJECT #: 200823
 SHEET NUMBER
EC4
 4 OF 24

NO CHANGES ARE TO BE MADE TO THIS DRAWING WITHOUT WRITTEN PERMISSION OF HARRIS KOCHER SMITH.

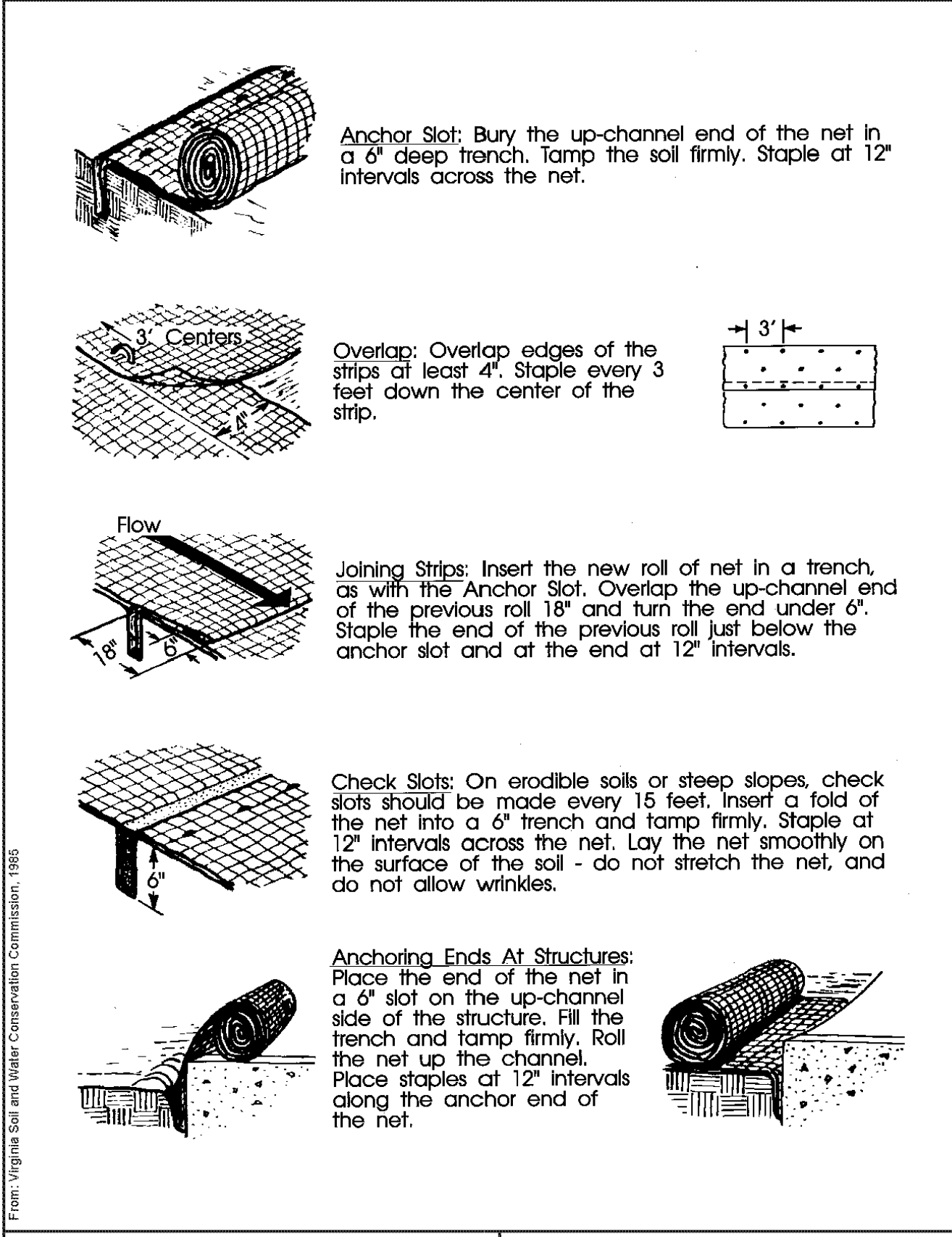

City of Colorado Springs Storm Water Quality
Figure ECB-2
Erosion Control Blanket Installation Requirements
DENM153722.CS.CDF/gcib-25-99

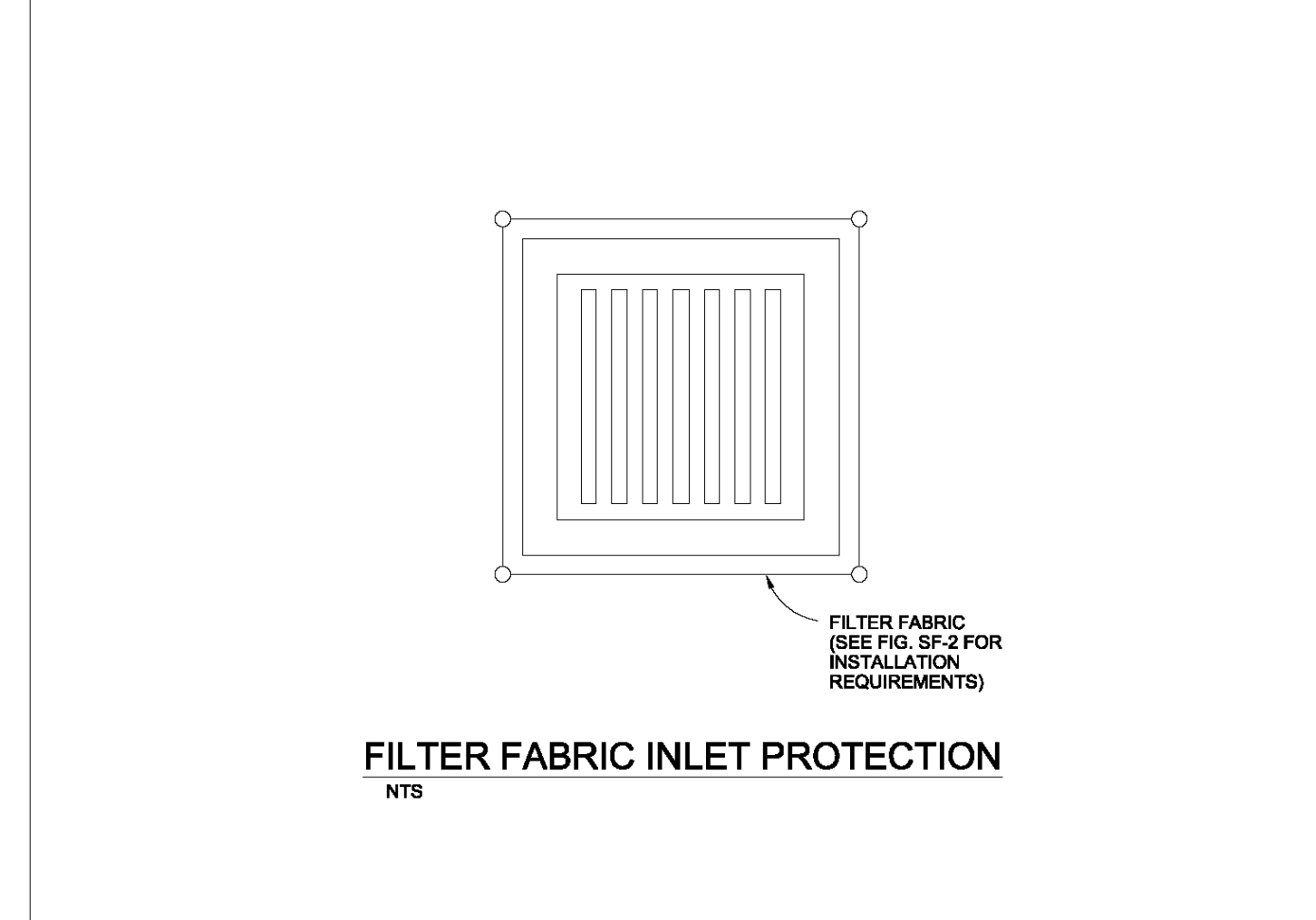

INSTALLATION REQUIREMENTS

- INLET PROTECTION SHALL BE INSTALLED IMMEDIATELY AFTER CONSTRUCTION OF INLET.
- SEE SILT FENCE FIGURE SF-2 FOR INSTALLATION REQUIREMENTS.
- POSTS ARE TO BE PLACED AT EACH CORNER OF THE INLET AND AROUND THE EDGES AT A MAXIMUM SPACING OF 3 FEET.

MAINTENANCE REQUIREMENTS

- CONTRACTOR SHALL INSPECT INLET PROTECTION IMMEDIATELY AFTER EACH RAINFALL, AT LEAST DAILY DURING PROLONGED RAINFALL, AND WEEKLY DURING PERIODS NO RAINFALL.
- DAMAGED, COLLAPSED, UNINTRENCHED OR INEFFECTIVE INLET PROTECTION SHALL BE PROMPTLY REPAIRED OR REPLACED.
- SEDIMENT SHALL BE REMOVED FROM BEHIND FILTER FABRIC WHEN IT ACCUMULATES TO HALF THE EXPOSED GEOTEXTILE HEIGHT.
- FILTER FABRIC PROTECTION SHALL BE REMOVED WHEN ADEQUATE VEGETATIVE COVER IS ATTAINED IN THE DRAINAGE AREA AS APPROVED BY THE CITY.

City of Colorado Springs Stormwater Quality
Figure IP-1
Filter Fabric Inlet Protection
Construction Detail and Maintenance Requirements

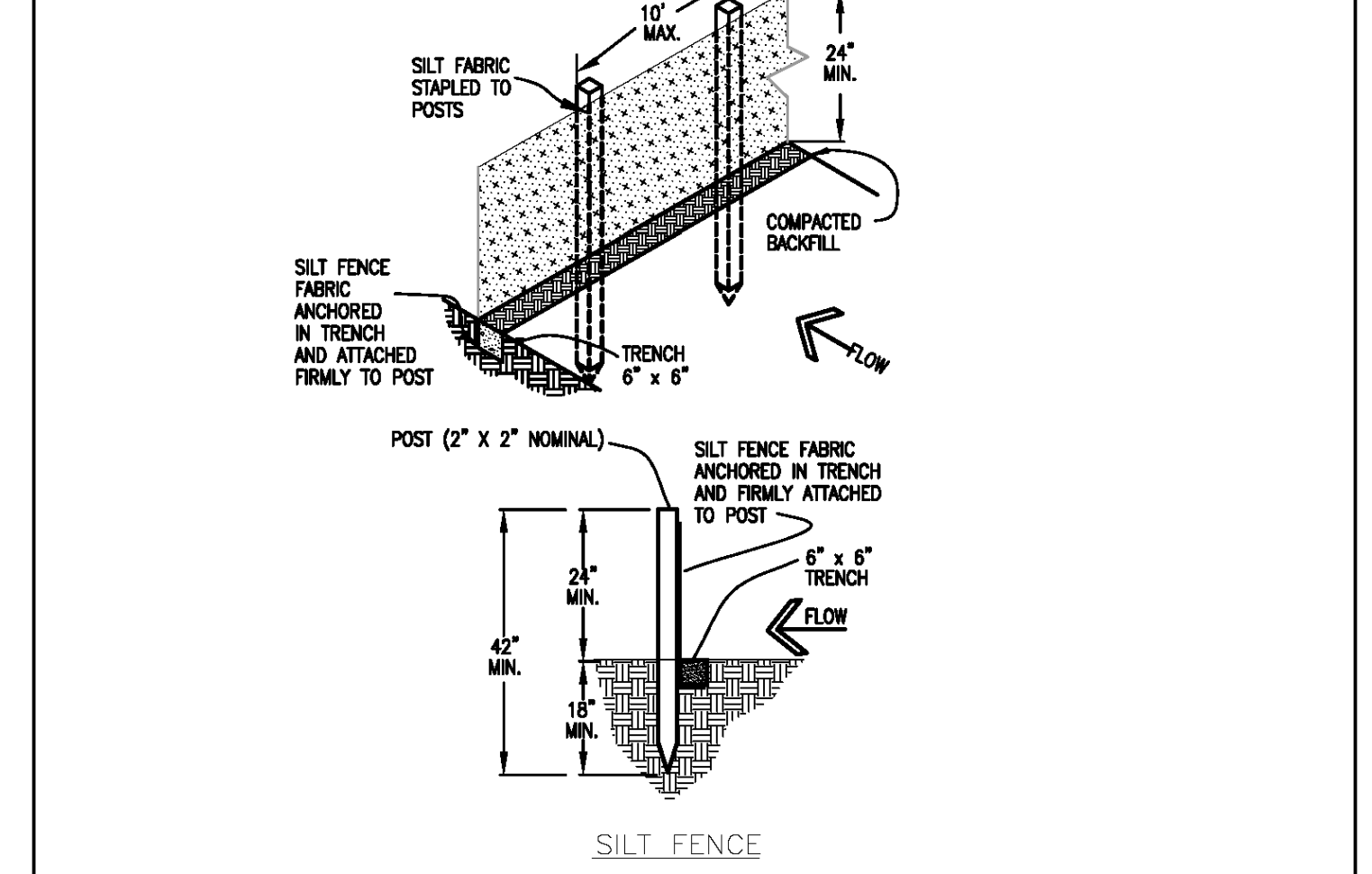
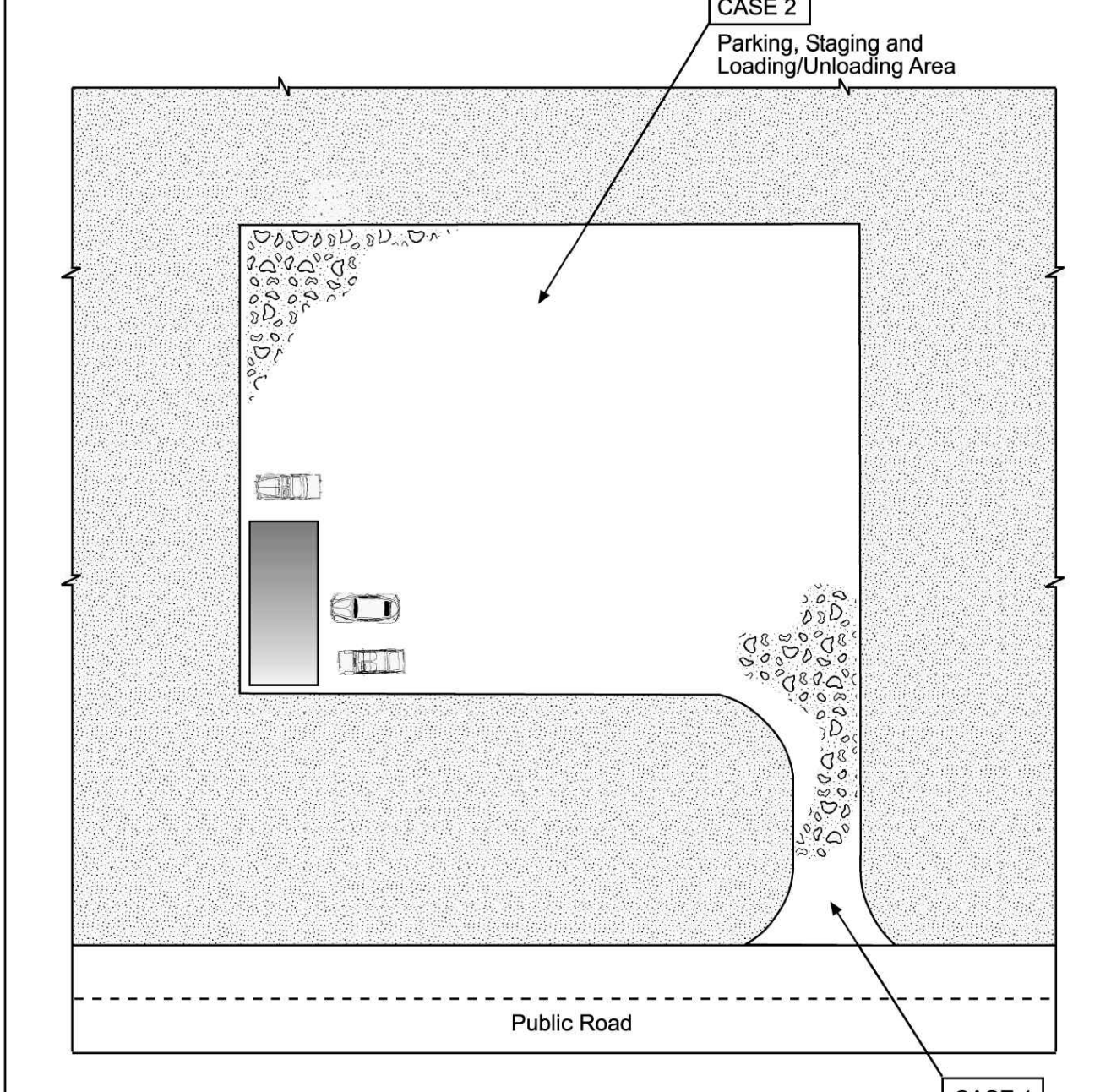

SILT FENCE NOTES

INSTALLATION REQUIREMENTS

- SILT FENCES SHALL BE INSTALLED PRIOR TO ANY LAND DISTURBING ACTIVITIES.
- WHEN JOINTS ARE NECESSARY, SILT FENCE GEOTEXTILE SHALL BE SPLICED TOGETHER ONLY AT SUPPORT POST AND SECURELY SEALED.
- METAL POSTS SHALL BE "STUDDED TEE" OR "U" TYPE WITH MINIMUM WEIGHT OF 1.33 POUNDS PER LINEAR FOOT. WOOD POSTS SHALL HAVE A MINIMUM DIAMETER OR CROSS SECTION DIMENSION OF 2 INCHES.
- THE FILTER MATERIAL SHALL BE FASTENED SECURELY TO METAL OR WOOD POSTS USING WIRE TIES, OR TO WOOD POSTS WITH 3/4" LONG #9 HEAVY-DUTY STAPLES. THE SILT FENCE GEOTEXTILE SHALL NOT BE STAPLED TO EXISTING TREES.
- WHILE NOT REQUIRED, WIRE MESH FENCE MAY BE USED TO SUPPORT THE GEOTEXTILE. WIRE FENCE SHALL BE FASTENED SECURELY TO THE UPSLOPE SIDE OF THE POSTS USING HEAVY-DUTY WIRE STAPLES AT LEAST 3/4" LONG, TIE WIRES OR HOG RINGS. THE WIRE SHALL EXTEND INTO THE TRENCH A MINIMUM OF 6" AND SHALL NOT EXTEND MORE THAN 3" ABOVE THE ORIGINAL GROUND SURFACE.

MAINTENANCE REQUIREMENTS

- CONTRACTOR SHALL INSPECT SILT FENCES IMMEDIATELY AFTER EACH RAINFALL, AND WEEKLY DURING PERIODS OF NO RAINFALL. DAMAGED, COLLAPSED, UNINTRENCHED OR INEFFECTIVE SILT FENCES SHALL BE PROMPTLY REPAIRED OR REPLACED.
- SEDIMENT SHALL BE REMOVED FROM BEHIND SILT FENCE WHEN IT ACCUMULATES TO HALF THE EXPOSED GEOTEXTILE HEIGHT.
- SILT FENCES SHALL BE REMOVED FROM BEHIND ADEQUATE VEGETATIVE COVER IS ATTAINED AS APPROVED BY THE CITY.

ALONG THE TOE OF FILLS, INSTALL THE SILT FENCE ALONG A LEVEL CONTOUR AND PROVIDE AN AREA BEHIND THE FENCE FOR RUNOFF TO POND AND SEDIMENT TO SETTLE. A MINIMUM DISTANCE OF 5 FEET FROM THE TOE OF THE FILL IS RECOMMENDED.

City of Colorado Springs Stormwater Quality
Figure SF-2
Silt Fence
Construction Detail and Maintenance Requirements

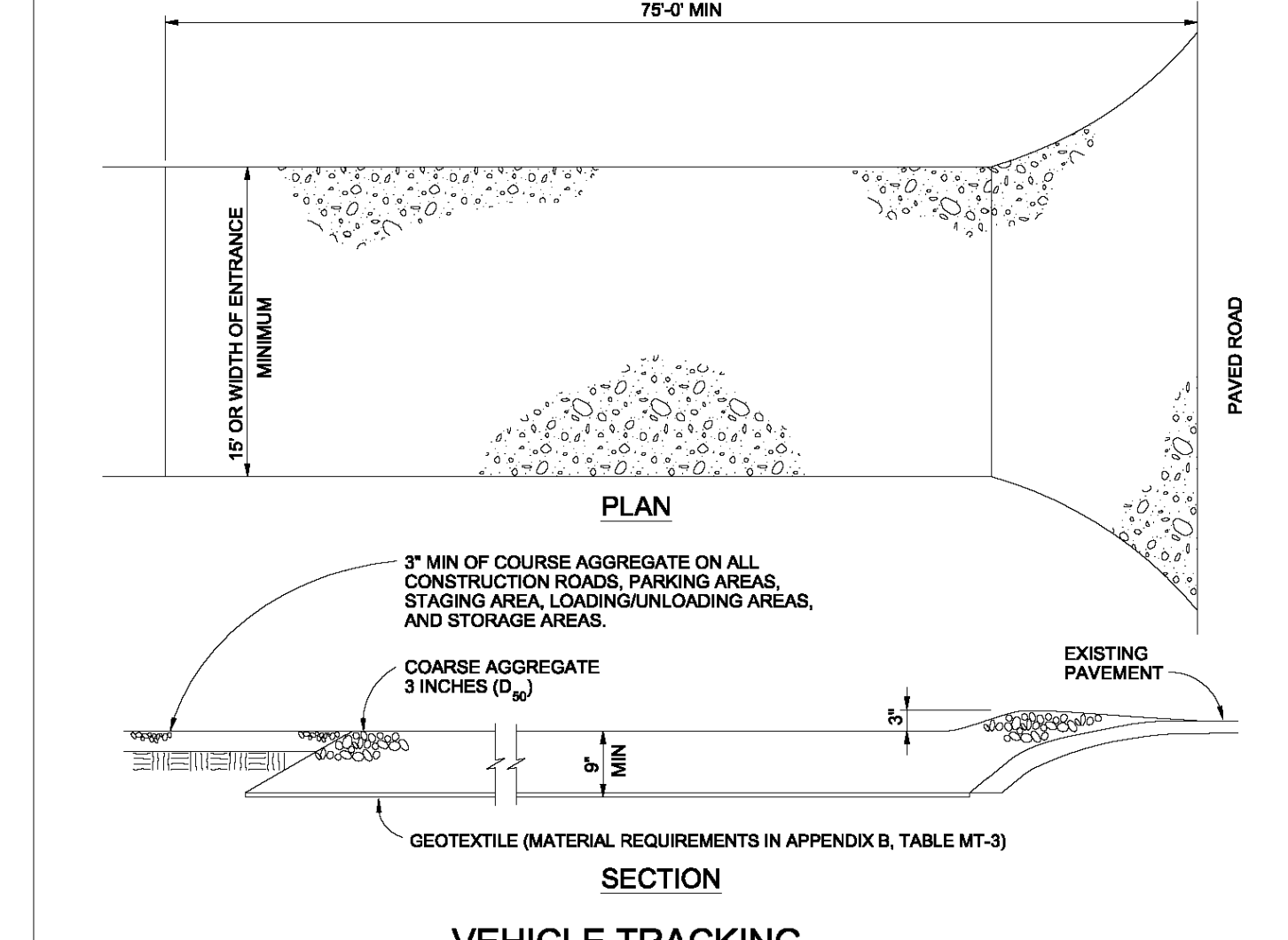
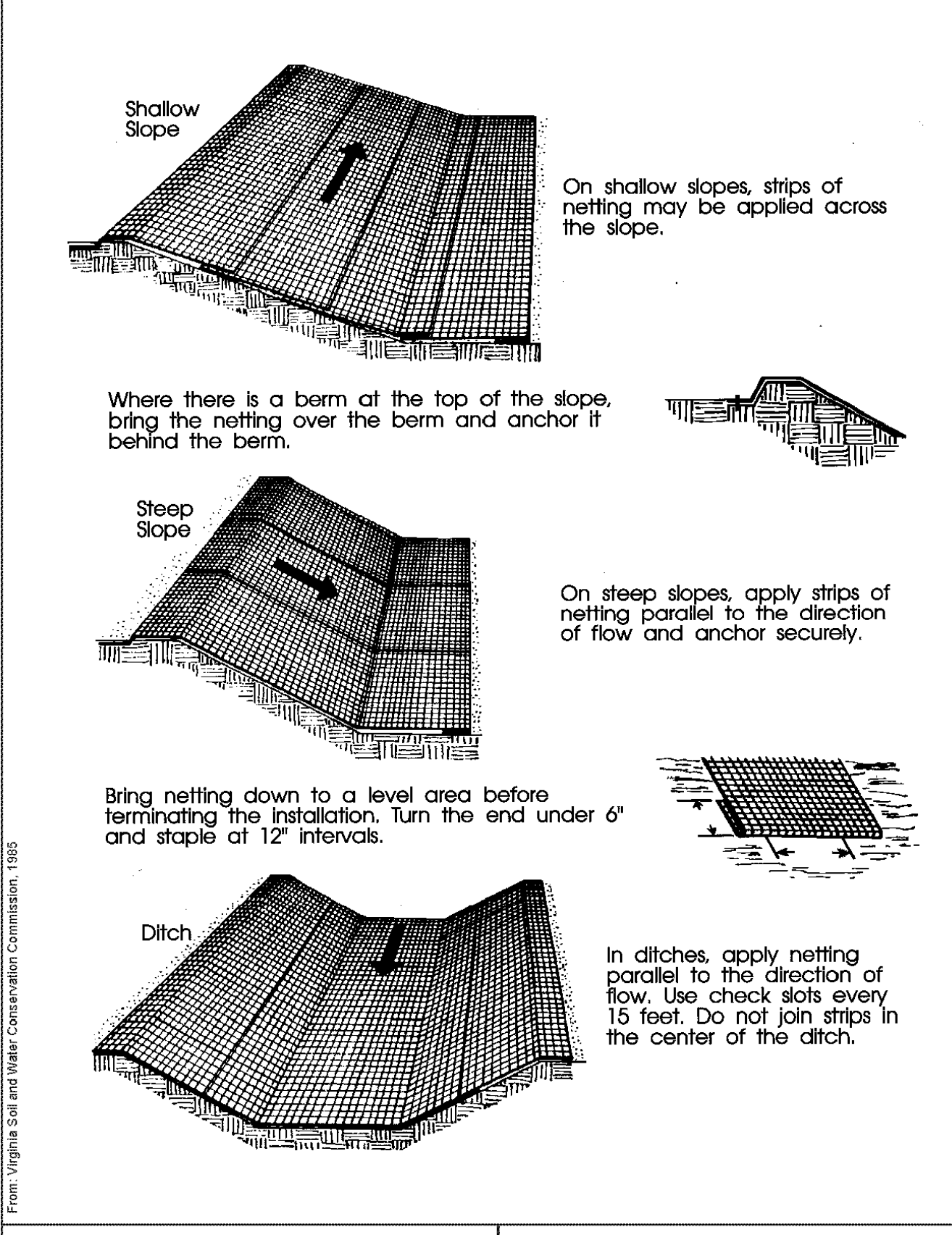

INSTALLATION REQUIREMENTS

- ALL ENTRANCES TO THE CONSTRUCTION SITE ARE TO BE STABILIZED PRIOR TO CONSTRUCTION BEGINNING.
- CONSTRUCTION ENTRANCES ARE TO BE BUILT WITH AN APRON TO ALLOW FOR TURNING TRAFFIC, BUT SHOULD NOT BE BUILT OVER EXISTING PAVEMENT EXCEPT FOR A SLIGHT OVERLAP.
- AREAS TO BE STABILIZED ARE TO BE PROPERLY GRADED AND COMPACTED PRIOR TO LAYING DOWN GEOTEXTILE AND STONE.
- CONSTRUCTION ROADS, PARKING AREAS, LOADING/UNLOADING ZONES, STORAGE AREAS, AND STAGING AREAS ARE TO BE STABILIZED.
- CONSTRUCTION ROADS ARE TO BE BUILT TO CONFORM TO SITE GRADES, BUT SHOULD NOT HAVE SIDE SLOPES OR ROAD GRADES THAT ARE EXCESSIVELY STEEP.

MAINTENANCE REQUIREMENTS

- REGULAR INSPECTIONS ARE TO BE MADE OF ALL STABILIZED AREAS, ESPECIALLY AFTER STORM EVENTS.
- STONES ARE TO BE REAPPLIED PERIODICALLY AND WHEN REPAIR IS NECESSARY.
- SEDIMENT TRACKED ONTO PAVED ROADS IS TO BE REMOVED DAILY BY SHOVELING OR SWEEPING. SEDIMENT IS NOT TO BE WASHED DOWN STORM SEWER DRAINS.
- STORM SEWER INLET PROTECTION IS TO BE IN PLACE, INSPECTED, AND CLEANED IF NECESSARY.
- OTHER ASSOCIATED SEDIMENT CONTROL MEASURES ARE TO BE INSPECTED TO ENSURE GOOD WORKING CONDITION.

City of Colorado Springs Stormwater Quality
Figure VT-2
Vehicle Tracking Application Examples

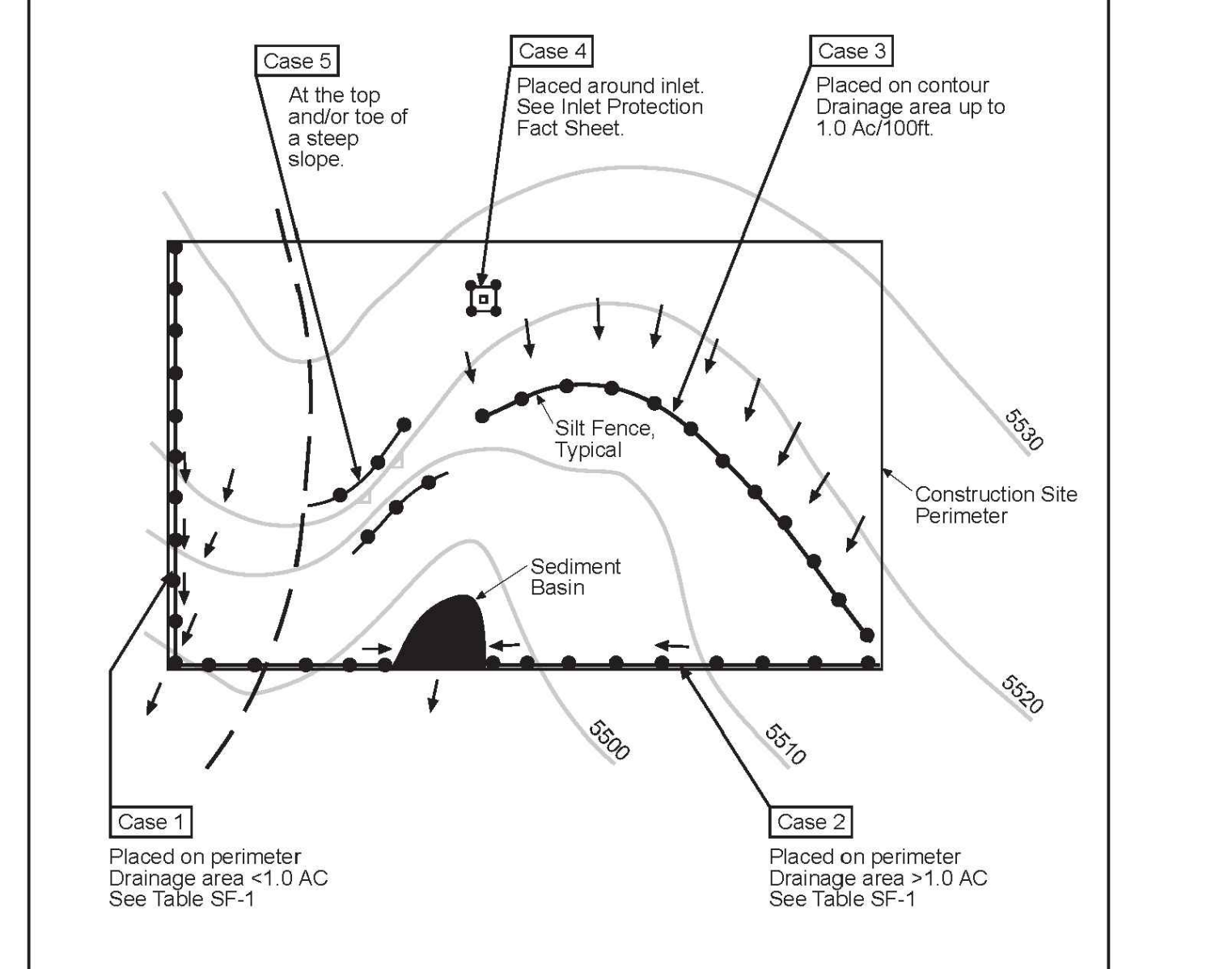
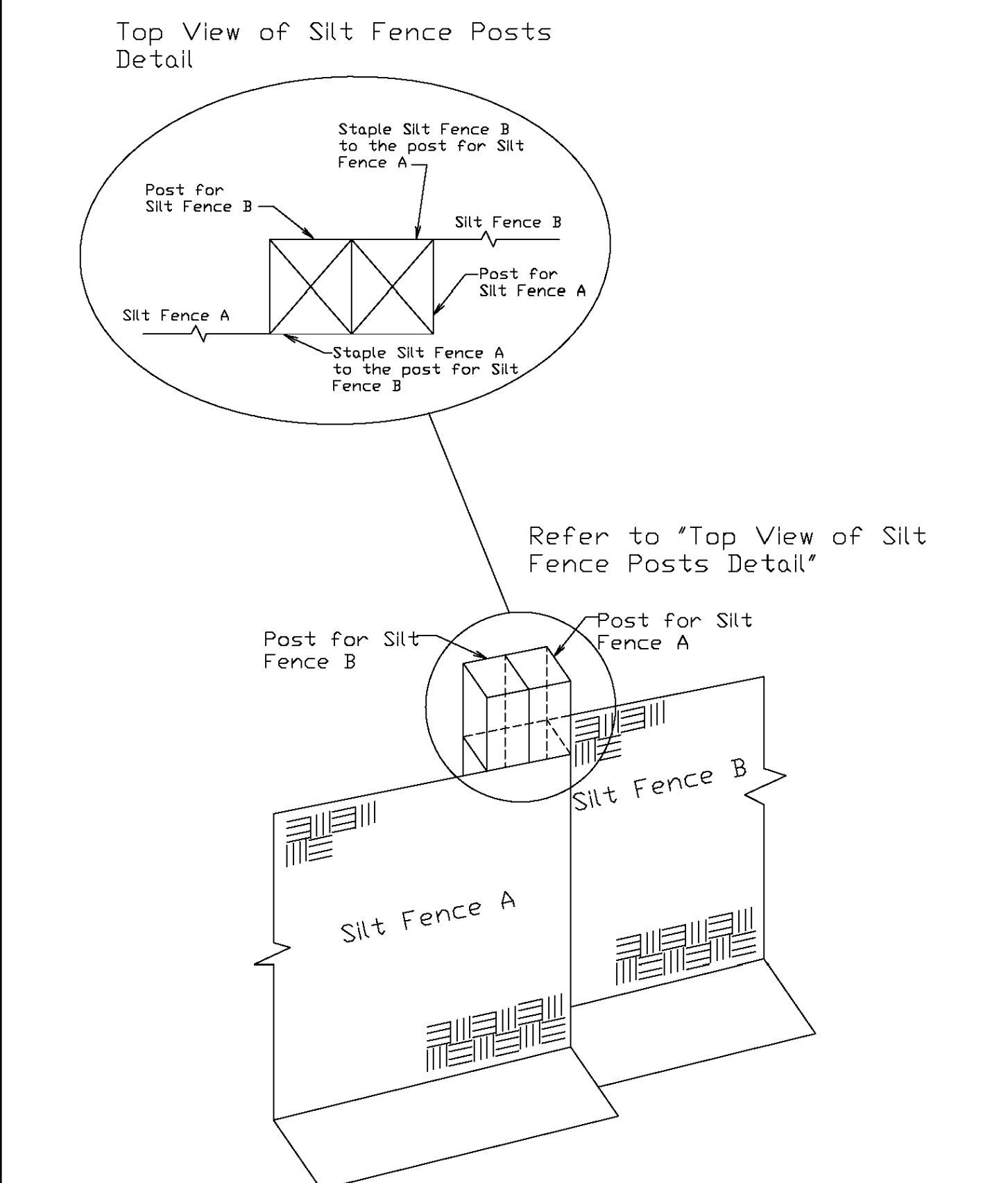

Table SF-1

Silt Fence Used as Perimeter Control	Case 1		
	DA < 0.25 AC	0.25 < DA < 1 AC	Case 2, DA > 1.0 AC
Continuous Grade	OK ⁽¹⁾	OK ⁽¹⁾	OK ⁽¹⁾
Area of Concentrated Flow	OK	NO ⁽²⁾	NO ⁽³⁾

(1) Temporary Shale or Straw Bale Barrier may be used as alternative to a Silt Fence.
(2) Check Dam may also be used as alternative to Silt Fence at low point.
(3) Sediment Basin is required for concentrated flow from drainage areas > 1.0 AC.

City of Colorado Springs Storm Water Quality
Figure SF-1
Silt Fence Application Examples
DENM153722.CS.CDF/gcib-25-99

FILE PATH: K:\2008\2008ENGINEERING\EROSION\GESC - DETAILS\DWG_LAYOUT\LAYOUT1.DWG
DESIGNED BY: AJH
CHECKED BY: JDO
DRAWN BY: AJH
PLOTTED: TUE 11/02/21 12:34:29P BY: ETHAN MARKS



DESIGNED BY: AJH
CHECKED BY: JDO
DRAWN BY: AJH

ISSUE DATE: 08-06-2021

DATE	REVISION COMMENTS
10-29-2021	PER COUNTY COMMENTS



TRINISIC ACQUISITION COMPANY, LLC

AURA AT CROSSROADS
GRADING AND EROSION CONTROL - DETAILS

PRELIMINARY
NOT FOR
CONSTRUCTION

PROJECT #: 200823
SHEET NUMBER
EC5
5 OF 24

NO CHANGES ARE TO BE MADE TO THIS DRAWING WITHOUT WRITTEN PERMISSION OF HARRIS KOCHER SMITH.

Inlet Protection (IP) SC-6

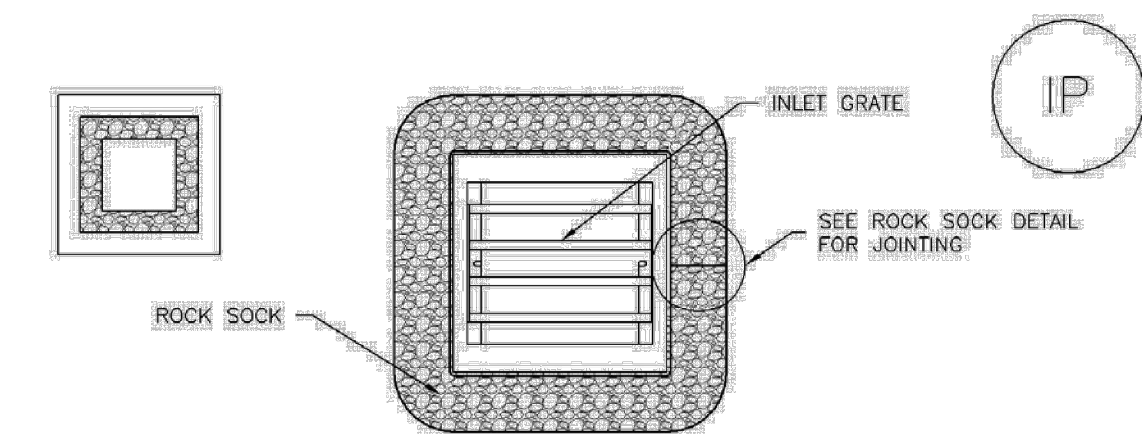

IP-3. ROCK SOCK SUMP/AREA INLET PROTECTION

ROCK SOCK SUMP/AREA INLET PROTECTION INSTALLATION NOTES
 1. SEE ROCK SOCK DESIGN DETAIL FOR INSTALLATION REQUIREMENTS.
 2. STRAW WATTLES/SEDIMENT CONTROL LOGS MAY BE USED IN PLACE OF ROCK SOCKS FOR INLETS IN PERVIOUS AREAS. INSTALL PER SEDIMENT CONTROL LOG DETAIL.

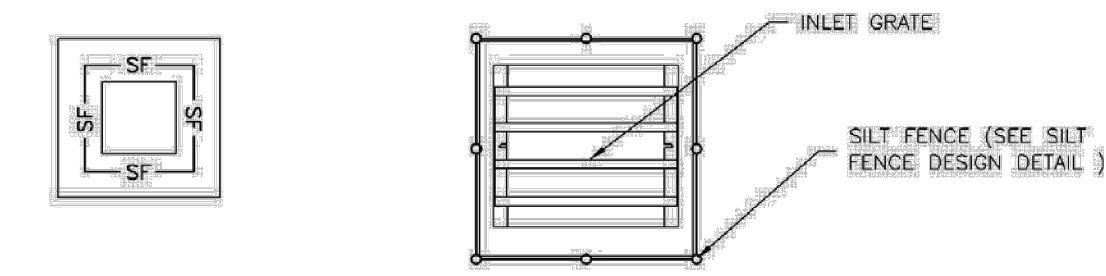

IP-4. SILT FENCE FOR SUMP INLET PROTECTION

SILT FENCE INLET PROTECTION INSTALLATION NOTES
 1. SEE SILT FENCE DESIGN DETAIL FOR INSTALLATION REQUIREMENTS.
 2. POSTS SHALL BE PLACED AT EACH CORNER OF THE INLET AND AROUND THE EDGES AT A MAXIMUM SPACING OF 3 FEET.
 3. STRAW WATTLES/SEDIMENT CONTROL LOGS MAY BE USED IN PLACE OF SILT FENCE FOR INLETS IN PERVIOUS AREAS. INSTALL PER SEDIMENT CONTROL LOG DETAIL.

August 2013 Urban Drainage and Flood Control District IP-5
 Urban Storm Drainage Criteria Manual Volume 3

SC-6 Inlet Protection (IP)

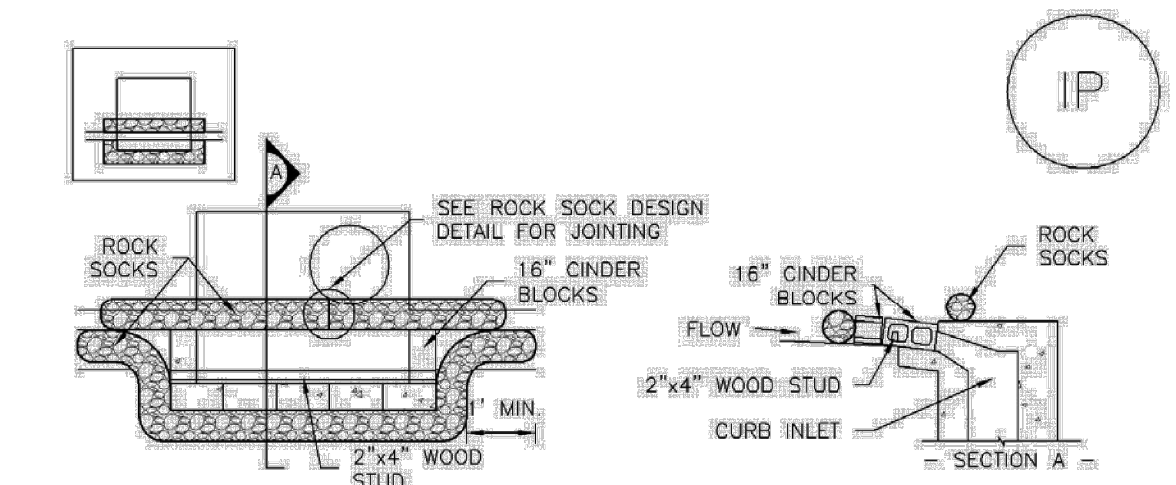

IP-1. BLOCK AND ROCK SOCK SUMP OR ON GRADE INLET PROTECTION

BLOCK AND CURB SOCK INLET PROTECTION INSTALLATION NOTES
 1. SEE ROCK SOCK DESIGN DETAIL FOR INSTALLATION REQUIREMENTS.
 2. CONCRETE "CINDER" BLOCKS SHALL BE LAID ON THEIR SIDES AROUND THE INLET IN A SINGLE ROW, ABUTTING ONE ANOTHER WITH THE OPEN END FACING AWAY FROM THE CURB.
 3. GRAVEL BAGS SHALL BE PLACED AROUND CONCRETE BLOCKS, CLOSELY ABUTTING ONE ANOTHER AND JOINTED TOGETHER IN ACCORDANCE WITH ROCK SOCK DESIGN DETAIL.

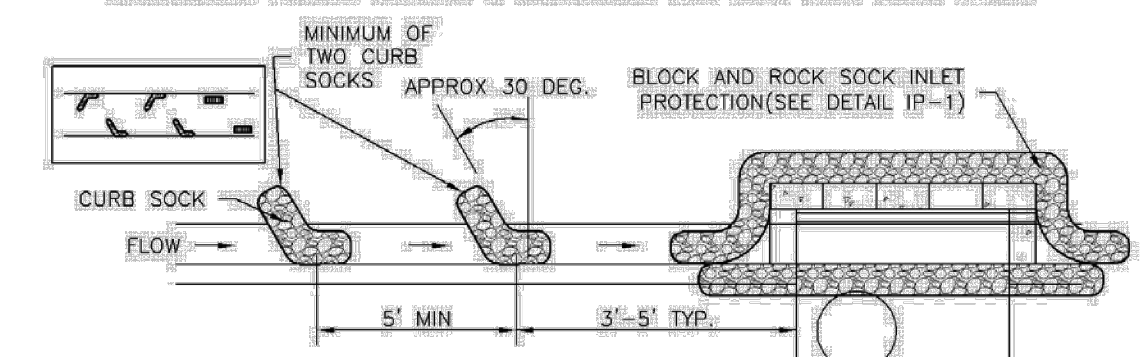

IP-2. CURB ROCK SOCKS UPSTREAM OF INLET PROTECTION

CURB ROCK SOCK INLET PROTECTION INSTALLATION NOTES
 1. SEE ROCK SOCK DESIGN DETAIL INSTALLATION REQUIREMENTS.
 2. PLACEMENT OF THE SOCK SHALL BE APPROXIMATELY 30 DEGREES FROM PERPENDICULAR IN THE OPPOSITE DIRECTION OF FLOW.
 3. SOCKS ARE TO BE FLUSH WITH THE CURB AND SPACED A MINIMUM OF 5 FEET APART.
 4. AT LEAST TWO CURB SOCKS IN SERIES ARE REQUIRED UPSTREAM OF ON-GRADE INLETS.

IP-4 Urban Drainage and Flood Control District August 2013
 Urban Storm Drainage Criteria Manual Volume 3

Design Volume (acres-ft)	Depth at Outlet (ft)								
	1.0	1.5	2.0	2.5	3.0	3.5	4.0	4.5	
2	15.04	7.71	5.10	3.76	2.95	2.41	2.02	1.73	
1	7.52	3.86	2.55	1.88	1.48	1.21	1.01	0.87	
0.6	4.51	2.31	1.53	1.13	0.89	0.72	0.61	0.52	
0.4	3.01	1.54	1.02	0.75	0.59	0.48	0.40	0.35	
0.2	1.50	0.77	0.51	0.38	0.30	0.24	0.20	0.17	
0.1	0.75	0.39	0.26	0.19	0.15	0.12	0.10	0.09	
0.06	0.45	0.23	0.15	0.11	0.09	0.07	0.06	0.05	
0.04	0.30	0.15	0.10	0.08	0.06	0.05	0.04	0.03	
0.02	0.15	0.08	0.05	0.04	0.03	0.02	0.02	0.02	
0.01	0.08	0.04	0.03	0.02	0.01	0.01	0.01	0.01	

TABLE SB-1

Hole Diameter (in)	Hole Diameter (ft)	Area per Row (in ²)		
		n = 1	n = 2	n = 3
1/4	0.250	0.05	0.10	0.15
5/16	0.313	0.08	0.15	0.23
3/8	0.375	0.11	0.22	0.33
7/16	0.438	0.15	0.30	0.45
1/2	0.500	0.20	0.39	0.59
9/16	0.563	0.26	0.50	0.75
5/8	0.625	0.31	0.61	0.92
11/16	0.688	0.37	0.74	1.11
3/4	0.750	0.44	0.88	1.33
7/8	0.875	0.60	1.20	1.80
1	1.000	0.79	1.57	2.36
1 1/8	1.125	0.99	1.99	2.98
1 1/4	1.250	1.23	2.45	3.68
1 3/8	1.375	1.48	2.97	4.45
1 1/2	1.500	1.77	3.53	5.30
1 5/8	1.625	2.07	4.15	6.22
1 3/4	1.750	2.41	4.81	7.22
1 7/8	1.875	2.76	5.52	8.28
2	2.000	3.14	6.28	9.42

n = Number of columns of perforations

Minimum steel plate thickness	1/4"	5/16"	3/8"
-------------------------------	------	-------	------

TABLE SB-2

City of Colorado Springs Stormwater Quality Figure SB-2 Outlet Sizing Application Techniques and Maintenance Requirements

3-33

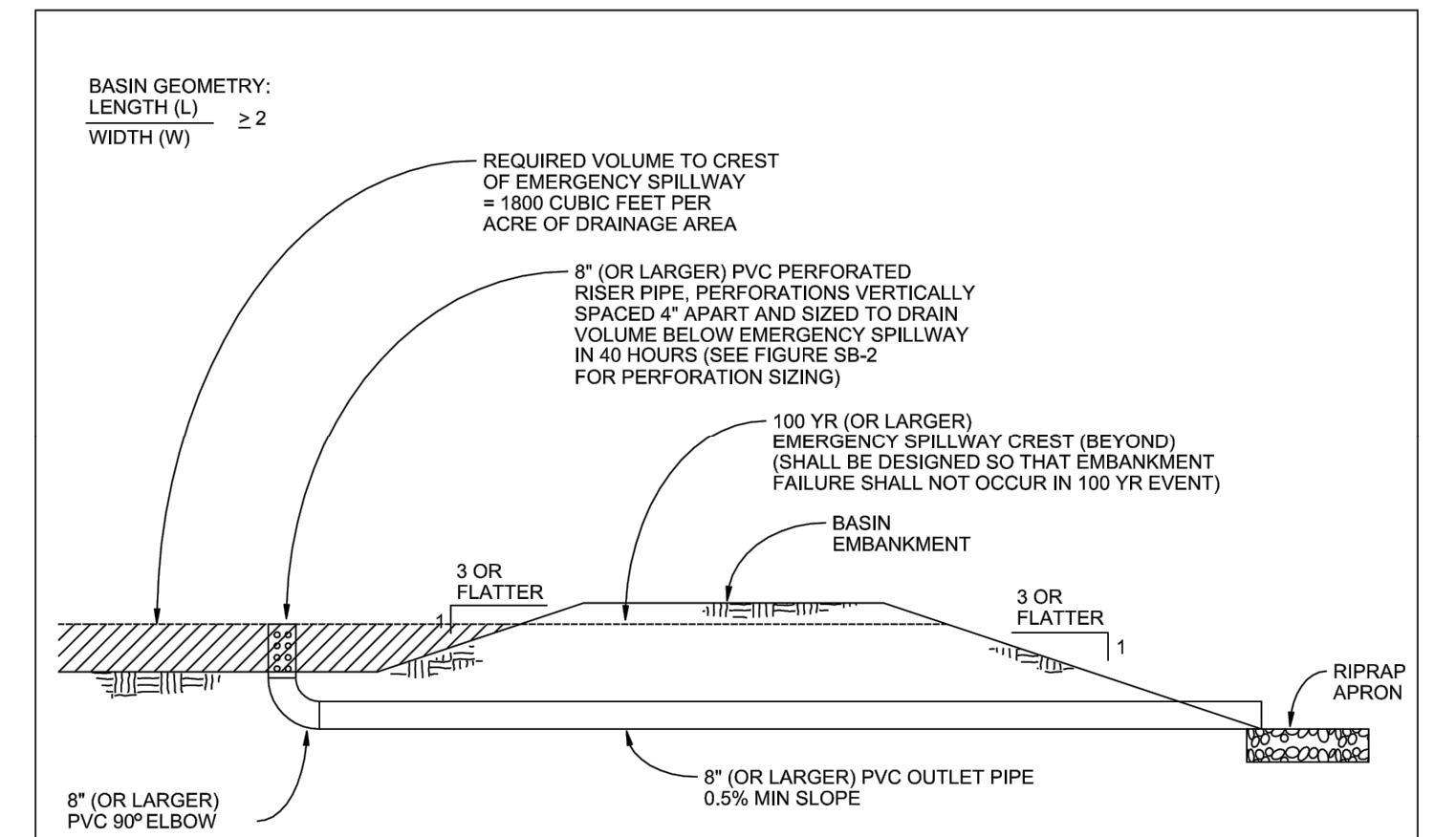

SEDIMENT BASIN NOTES

INSTALLATION REQUIREMENTS
 1. SEDIMENT BASINS SHALL BE INSTALLED BEFORE ANY CLEARING AND/OR GRADING IS UNDERTAKEN.
 2. THE AREA UNDER WHICH THE EMBANKMENT IS TO BE INSTALLED SHALL BE CLEARED, GRUBBED, AND STRIPPED OF ALL VEGETATION AND ROOT MAT.
 3. THE OUTLET OF THE BASIN SHALL BE DESIGNED TO DRAIN ITS VOLUME IN 40 HOURS.
 4. THE OUTLET IS TO BE LOCATED AT THE FURTHEST DISTANCE FROM THE INLET OF THE BASIN. BAFFLES MAY BE NEEDED TO INCREASE THE FLOW LENGTH AND SETTLING TIME.
 5. EMBANKMENT MATERIAL SHALL CONSIST OF SOIL WITH A MINIMUM OF 15% PASSING A #20 SIEVE. EXCAVATED SOIL CAN BE USED IF IT MEETS THIS REQUIREMENT.
 6. EMBANKMENT IS TO BE COMPACTED TO AT LEAST 90% OF MAXIMUM DENSITY AND WITHIN 2% OF OPTIMUM MOISTURE CONTENT ACCORDING TO ASTM D 698.
 7. WHEN A BASIN IS INSTALLED NEAR A RESIDENTIAL AREA, FOR SAFETY REASONS, A SIGN SHALL BE POSTED AND THE AREA SECURED WITH A FENCE.

MAINTENANCE REQUIREMENTS
 1. CONTRACTOR SHALL INSPECT SEDIMENT BASINS AFTER EACH RAINFALL AT LEAST DAILY DURING PROLONGED RAINFALL, AND WEEKLY DURING PERIODS OF NO RAINFALL.
 2. SEDIMENT BASINS SHALL BE CLEANED OUT BEFORE SEDIMENT HAS FILLED HALF THE VOLUME OF THE BASIN.
 3. SEDIMENT BASINS SHALL REMAIN OPERATIONAL AND PROPERLY MAINTAINED UNTIL THE SITE AREA IS PERMANENTLY STABILIZED WITH ADEQUATE VEGETATIVE COVER AND/OR OTHER PERMANENT STRUCTURE AS APPROVED BY THE CITY.

City of Colorado Springs Stormwater Quality Figure SB-1 Sediment Basin Construction Detail and Maintenance Requirements

3-32

FILE PATH: K:\200820\ENGINEERING\EROSION\SC-6 - DETAILS.DWG LAYOUT LAYOUT2
 1. DESIGNED BY: AJH
 2. CHECKED BY: JDO
 3. PLOTTED: TUE 11/02/21 12:34:29P BY: ETHAN MARKS



ISSUE DATE: 08-06-2021	
DATE	REVISION COMMENTS
10-29-2021	PER COUNTY COMMENTS

DESIGNED BY: AJH
 CHECKED BY: JDO
 DRAWN BY: AJH

HKS HARRIS KOCHER SMITH
 1120 Lincoln Street, Suite 1000
 Denver, Colorado 80203
 P: 303.623.6300 F: 303.623.6311
 HarrisKocherSmith.com

TRINISIC ACQUISITION COMPANY, LLC

AURA AT CROSSROADS
 GRADING AND EROSION CONTROL - DETAILS

PRELIMINARY NOT FOR CONSTRUCTION

PROJECT #: 200823
 SHEET NUMBER
EC6
 6 OF 24