



FINAL DRAINAGE LETTER

**7981 Fort Smith Road
Peyton, CO 80831**

LOT 593 WOODMEN HILLS FILING NO. 9
LOCATED IN SECTION 6, T 13 S, R 64 W OF THE 6TH PM
EL PASO COUNTY, STATE OF COLORADO

Prepared For:
Jerome Engel
7981 Fort Smith Road
Peyton, CO 80831

Prepared By:
Baseline Engineering Corporation
1046 Elkton Drive
Colorado Springs, Colorado 80907

Mark Sundstrom, PE
Steve Baggs, PE
JOB # 35079CS

Original Submittal: April 10, 2024

**BASELINE**

Engineering · Planning · Surveying



Table of Contents

Certification Statements	3
Engineer’s Statement.....	3
Developer’s Statement	3
El Paso County Certification.....	3
Introduction	4
Description of Project	4
Scope and Purpose of Report	4
Existing Drainage System	4
Proposed Drainage System	5
Conclusions	6
References	7
APPENDIX.....	8
Appendix A.....	9
Appendix B	10
Appendix C	11
Appendix D.....	12

Certification Statements

Engineer's Statement

The attached drainage plan and report were prepared under my direction and supervision and are correct to the best of my knowledge and belief. Said drainage report has been prepared according to the criteria established by the County for drainage reports and said report is in conformity with the applicable master plan of the drainage basin. I accept responsibility for any liability caused by any negligent acts, errors or omissions on my part in preparing this report.

Mark Sundstrom, P.E. Colorado 56102

Developer's Statement

I, the developer have read and will comply with all of the requirements specified in this drainage report and plan.

Name of Developer: _____

Authorized Signature/Date: _____

Printed Name: _____

Title: _____

Address: _____

El Paso County Certification

Filed in accordance with the requirements of the Drainage Criteria Manual, Volumes 1 and 2, El Paso County Engineering Criteria Manual and Land Development Code as amended.

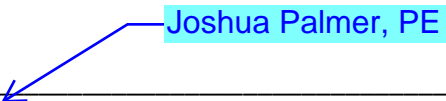

County Engineer / ECM Administrator

Date

Introduction

Description of Project

The subject property is located at 7981 Fort Smith Road in unincorporated El Paso County. It is legally known as Lot 593 of Woodmen Hills Filing No. 9. The proposed project includes construction of a RV garage on the north side of the existing single-family dwelling. The proposed garage adds approximately 1,800 sf of impervious area. The total disturbed area is approximately 4,000 sf.

Scope and Purpose of Report

The purpose of this letter is to demonstrate that the proposed improvements do not negatively impact the adjacent properties. It also supports a Plat Note Waiver action that will remove the no-build area from the lot. Calculations were performed in compliance with the requirements set forth in the Drainage Criteria Manual County of El Paso, Colorado (hereafter referred to as the "County Manual") and the Mile High Flood District Criteria Manuals (hereafter referred to as the "District Manual").

Existing Drainage System

At the time of this report, grading for the building pad is complete. For the purposes of this report and in order to evaluate the impacts that the grading for the building pad has on the system, the "existing drainage" system will be evaluated as if the building pad had not been graded. The "proposed drainage" system will be evaluated with the building pad graded as-is.

The Final Drainage & Erosion Control Report for Woodmen Hills Subdivision Filing 9, Falcon, El Paso County, Colorado by URS Greiner Woodward Clyde dated October 19, 1999 (hereafter referred to as the "Master Drainage Report") provides the drainage information for the subject property. However, the drainage basin delineated on the drainage plans and the upstream neighborhood does not accurately depict the existing conditions.

Due to the discrepancies found in the Master Drainage Report described above, a new drainage basin was delineated using Lidar contours and aerial mapping. This basin E1 was found to be 14.23 acres in size. The same runoff coefficients were

used as in the Master Drainage Report, with the 5-yr coefficient being 0.41 and the 100-yr coefficient being 0.50. The 5-yr and 100-yr flow rates were found to be 8.4 cfs and 21.1 cfs, respectively.

RUNOFF SUMMARY							
BASIN LABEL	DESIGN POINT	AREA	Imp.	C5	C100	LOCAL (CFS)	
						Q5	Q100
E1	E1	14.23	0.45	0.41	0.50	8.4	21.1

Table 1 – Runoff Summary

To evaluate the existing drainage channel, a cross section was cut at station 0+75 where no grading has been performed. The existing channel is approximately 100ft wide and 4ft deep. Refer to Table 2 provided below for the flow, depth, velocity, and Froude number associated with station 0+75 that represents the existing conditions.

Proposed Drainage System

The proposed improvements include a standalone RV garage located on the north side of the single-family dwelling. The proposed RV garage building pad extends into the existing drainage channel. The proposed drainage channel reduces the typical channel dimensions to approximately 30ft wide and 3.4ft deep. To evaluate the proposed improvements, a cross section at station 0+25 was created at the location of the grading that has already been performed. Table 2, presented below, compares the flow, depth, velocity, and Froude Number associated with station 0+25 (the proposed condition) and station 0+75 (the existing condition) for both the 5-yr and 100-yr storm events.

Storm Event	Station	Flow (cfs)	Depth (in)	Velocity (ft/s)	Froude Number
5-yr	0+25 (proposed)	8.4	12.0	1.09	0.238
5-yr	0+75 (existing)	8.4	7.7	0.70	0.216
100-yr	0+25 (proposed)	21.1	18.3	1.42	0.254
100-yr	0+75 (existing)	21.1	10.8	0.96	0.233

Table 2 – Results Summary

Please include a discussion of what type of channel lining was used as the basis for the Mannings value and maximum allowed velocities

In the 5-yr storm event, the flow depth increases by approximately 4.3 inches and the velocity in the channel increases by 0.39 ft/s. In the 100-yr storm event, the depth in the channel increases by 7.5 inches and the velocity increases by 0.46 ft/s. In both scenarios, the Froude Number remains below 0.3. The threshold for most swale stabilization techniques is a Froude Number equal to or greater than 0.8. Therefore, the swale is anticipated to be at a low risk for erosion and scour.

It is recommended that the owner/contractor implement several measures to protect the proposed structure. This includes providing positive drainage away from the structure and adding an erosion blanket, riprap protection or other stabilization techniques along the slope of the building pad to mitigate erosion of the building pad.

Please include a discussion of any impact to the neighboring properties that will need to be addressed such as deeper flows or changes in velocity up and down stream of the subject property

Conclusions

This letter summarizes the drainage improvements associated with the proposed RV garage. The proposed improvements increase the flow depth in the drainage swale by 4.3 inches and 7.5 inches for the 5-yr and 100-yr storm events, respectively. The erosion and scour potential in the drainage swale is considered low as the Froude Number remains less than 0.3 for both scenarios.

No floodplains are impacted by these improvements. No drainage requirements were found in the Master Drainage Report. The stormwater management system is designed to accommodate the 5-yr and 100-yr storm events in accordance with the District and County Manuals.

References

1. **Master Drainage Report:** Final Drainage & Erosion Control Report for Woodmen Hills Subdivision Filing 9, Falcon, El Paso County, Colorado; URS Greiner Woodward Clyde; October 19, 1999.
2. **District Manual:** Mile High Flood District Criteria Manual Volumes 1, 2, & 3; Mile High Flood District, Denver, Colorado. Updated January 2016.
3. **County Manual:** Drainage Criteria Manual County of El Paso, Colorado. Revised October 31, 2018.
4. Web Soil Survey; Natural Resources Conservation Service. Accessed March 2024.

APPENDIX

Appendix A

Vicinity Map

FEMA FIRM

VICINITY MAP

7981 FORT SMITH ROAD

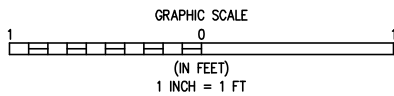
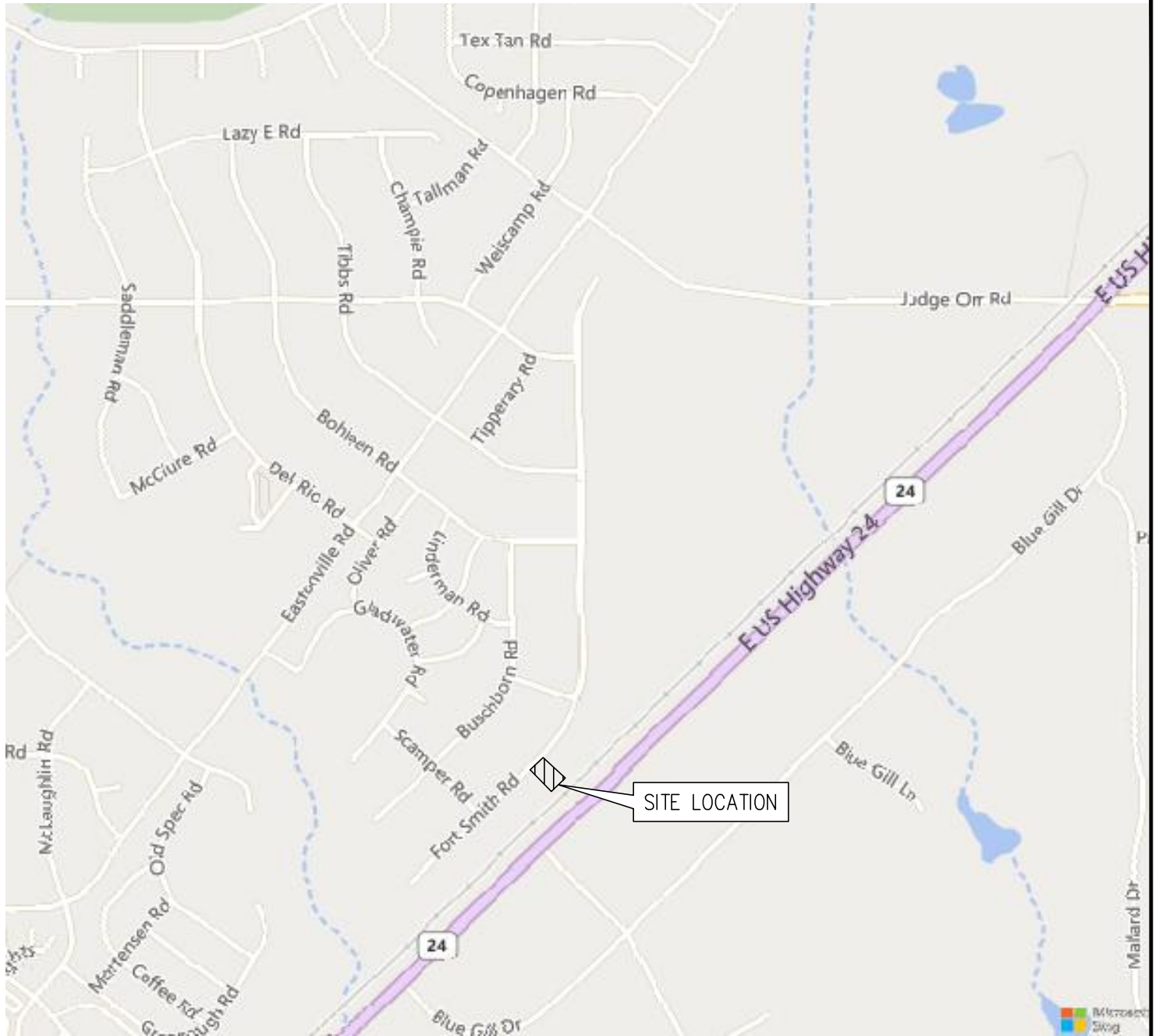

BASELINE

Engineering - Planning - Surveying

112 N RUBEY DRIVE, SUITE 210 - GOLDEN, COLORADO 80403
P. 303.940.9966 - F. 303.940.9969 - www.baselinecorp.com

National Flood Hazard Layer FIRMMette



104°35'48"W 38°57'2"N



Legend

SEE FIS REPORT FOR DETAILED LEGEND AND INDEX MAP FOR FIRM PANEL LAYOUT

- | | | |
|-----------------------------|--|--|
| SPECIAL FLOOD HAZARD AREAS | | Without Base Flood Elevation (BFE)
<i>Zone A, V, A99</i> |
| | | With BFE or Depth <i>Zone AE, AO, AH, VE, AR</i> |
| | | Regulatory Floodway |
| OTHER AREAS OF FLOOD HAZARD | | 0.2% Annual Chance Flood Hazard, Areas of 1% annual chance flood with average depth less than one foot or with drainage areas of less than one square mile <i>Zone X</i> |
| | | Future Conditions 1% Annual Chance Flood Hazard <i>Zone X</i> |
| | | Area with Reduced Flood Risk due to Levee. See Notes. <i>Zone X</i> |
| | | Area with Flood Risk due to Levee <i>Zone D</i> |
| OTHER AREAS | | NO SCREEN Area of Minimal Flood Hazard <i>Zone X</i> |
| | | Effective LOMRs |
| GENERAL STRUCTURES | | Area of Undetermined Flood Hazard <i>Zone D</i> |
| | | Channel, Culvert, or Storm Sewer |
| | | Levee, Dike, or Floodwall |
| OTHER FEATURES | | 20.2 Cross Sections with 1% Annual Chance |
| | | 17.5 Water Surface Elevation |
| | | Coastal Transect |
| | | Base Flood Elevation Line (BFE) |
| | | Limit of Study |
| MAP PANELS | | Jurisdiction Boundary |
| | | Coastal Transect Baseline |
| | | Profile Baseline |
| | | Hydrographic Feature |
| | | Digital Data Available |
| | | No Digital Data Available |
| | | Unmapped |
- The pin displayed on the map is an approximate point selected by the user and does not represent an authoritative property location.

This map complies with FEMA's standards for the use of digital flood maps if it is not void as described below. The basemap shown complies with FEMA's basemap accuracy standards

The flood hazard information is derived directly from the authoritative NFHL web services provided by FEMA. This map was exported on **4/10/2024 at 6:13 PM** and does not reflect changes or amendments subsequent to this date and time. The NFHL and effective information may change or become superseded by new data over time.

This map image is void if the one or more of the following map elements do not appear: basemap imagery, flood zone labels, legend, scale bar, map creation date, community identifiers, FIRM panel number, and FIRM effective date. Map images for unmapped and unmodernized areas cannot be used for regulatory purposes.

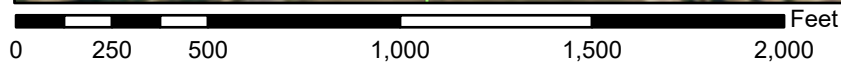

1:6,000

104°35'11"W 38°56'34"N

Basemap Imagery Source: USGS National Map 2023

Appendix B

NOAA Atlas Rainfall Data

Hydrologic Rational Calculations

Hydraulic Calculations



NOAA Atlas 14, Volume 8, Version 2
Location name: Peyton, Colorado, USA*
Latitude: 38.9466°, Longitude: -104.5915°
Elevation: 6885 ft**

* source: ESRI Maps
 ** source: USGS



POINT PRECIPITATION FREQUENCY ESTIMATES

Sanja Perica, Deborah Martin, Sandra Pavlovic, Ishani Roy, Michael St. Laurent, Carl Trypaluk, Dale Unruh, Michael Yekta, Geoffery Bonnin

NOAA, National Weather Service, Silver Spring, Maryland

[PF_tabular](#) | [PF_graphical](#) | [Maps & aerials](#)

PF tabular

PDS-based point precipitation frequency estimates with 90% confidence intervals (in inches)¹										
Duration	Average recurrence interval (years)									
	1	2	5	10	25	50	100	200	500	1000
5-min	0.238 (0.192-0.298)	0.290 (0.233-0.364)	0.380 (0.304-0.478)	0.459 (0.366-0.580)	0.576 (0.445-0.758)	0.671 (0.505-0.893)	0.770 (0.560-1.05)	0.876 (0.611-1.23)	1.02 (0.686-1.47)	1.14 (0.743-1.66)
10-min	0.349 (0.280-0.437)	0.425 (0.341-0.533)	0.557 (0.446-0.700)	0.673 (0.536-0.849)	0.843 (0.652-1.11)	0.982 (0.740-1.31)	1.13 (0.821-1.54)	1.28 (0.895-1.80)	1.50 (1.00-2.15)	1.67 (1.09-2.43)
15-min	0.425 (0.342-0.533)	0.518 (0.416-0.649)	0.679 (0.543-0.853)	0.820 (0.653-1.04)	1.03 (0.795-1.35)	1.20 (0.902-1.60)	1.38 (1.00-1.88)	1.56 (1.09-2.19)	1.83 (1.22-2.63)	2.04 (1.33-2.96)
30-min	0.611 (0.491-0.765)	0.744 (0.598-0.933)	0.973 (0.779-1.22)	1.18 (0.936-1.48)	1.47 (1.14-1.94)	1.71 (1.29-2.28)	1.96 (1.43-2.68)	2.23 (1.56-3.12)	2.61 (1.74-3.74)	2.90 (1.89-4.21)
60-min	0.785 (0.631-0.983)	0.941 (0.756-1.18)	1.22 (0.976-1.53)	1.47 (1.17-1.86)	1.86 (1.44-2.46)	2.18 (1.65-2.92)	2.52 (1.84-3.46)	2.90 (2.02-4.07)	3.43 (2.30-4.94)	3.86 (2.51-5.60)
2-hr	0.959 (0.777-1.19)	1.14 (0.921-1.42)	1.47 (1.18-1.83)	1.77 (1.42-2.22)	2.24 (1.76-2.96)	2.65 (2.02-3.52)	3.08 (2.27-4.20)	3.56 (2.52-4.98)	4.25 (2.88-6.10)	4.82 (3.16-6.94)
3-hr	1.05 (0.857-1.30)	1.23 (1.00-1.53)	1.58 (1.28-1.96)	1.91 (1.54-2.38)	2.43 (1.92-3.21)	2.89 (2.22-3.84)	3.39 (2.51-4.61)	3.95 (2.80-5.51)	4.76 (3.24-6.81)	5.42 (3.58-7.79)
6-hr	1.22 (1.00-1.50)	1.41 (1.16-1.73)	1.79 (1.46-2.21)	2.17 (1.76-2.68)	2.77 (2.22-3.65)	3.31 (2.57-4.39)	3.91 (2.93-5.30)	4.58 (3.29-6.37)	5.57 (3.83-7.93)	6.38 (4.24-9.11)
12-hr	1.40 (1.16-1.70)	1.63 (1.35-1.98)	2.07 (1.70-2.53)	2.50 (2.05-3.06)	3.18 (2.56-4.15)	3.78 (2.96-4.96)	4.45 (3.36-5.98)	5.19 (3.75-7.16)	6.28 (4.36-8.87)	7.17 (4.81-10.2)
24-hr	1.61 (1.34-1.94)	1.89 (1.58-2.28)	2.41 (2.00-2.91)	2.89 (2.39-3.52)	3.65 (2.95-4.68)	4.30 (3.38-5.57)	5.00 (3.80-6.64)	5.78 (4.20-7.88)	6.90 (4.82-9.66)	7.82 (5.29-11.0)
2-day	1.87 (1.57-2.23)	2.20 (1.85-2.63)	2.80 (2.34-3.36)	3.34 (2.78-4.03)	4.17 (3.38-5.28)	4.86 (3.84-6.22)	5.60 (4.27-7.35)	6.40 (4.68-8.64)	7.54 (5.30-10.5)	8.46 (5.77-11.8)
3-day	2.05 (1.73-2.44)	2.41 (2.04-2.87)	3.06 (2.57-3.65)	3.64 (3.04-4.37)	4.51 (3.68-5.68)	5.24 (4.16-6.67)	6.02 (4.62-7.86)	6.86 (5.04-9.20)	8.04 (5.68-11.1)	8.99 (6.17-12.5)
4-day	2.20 (1.87-2.61)	2.58 (2.19-3.07)	3.26 (2.75-3.88)	3.86 (3.24-4.62)	4.77 (3.90-5.98)	5.53 (4.40-7.01)	6.33 (4.87-8.24)	7.20 (5.31-9.63)	8.42 (5.98-11.6)	9.41 (6.48-13.1)
7-day	2.61 (2.22-3.07)	3.01 (2.57-3.55)	3.73 (3.17-4.41)	4.38 (3.69-5.20)	5.34 (4.40-6.64)	6.14 (4.93-7.74)	7.00 (5.43-9.05)	7.93 (5.89-10.5)	9.23 (6.60-12.6)	10.3 (7.13-14.2)
10-day	2.96 (2.54-3.47)	3.40 (2.91-3.99)	4.18 (3.56-4.91)	4.87 (4.13-5.75)	5.89 (4.87-7.28)	6.74 (5.43-8.44)	7.64 (5.94-9.82)	8.60 (6.42-11.4)	9.96 (7.14-13.6)	11.0 (7.69-15.2)
20-day	3.96 (3.42-4.60)	4.56 (3.93-5.30)	5.57 (4.79-6.50)	6.44 (5.51-7.55)	7.68 (6.37-9.35)	8.67 (7.02-10.7)	9.68 (7.58-12.3)	10.7 (8.06-14.0)	12.2 (8.80-16.4)	13.3 (9.35-18.2)
30-day	4.76 (4.13-5.50)	5.50 (4.77-6.36)	6.71 (5.80-7.79)	7.72 (6.64-9.01)	9.12 (7.58-11.0)	10.2 (8.29-12.5)	11.3 (8.87-14.2)	12.4 (9.35-16.1)	13.9 (10.1-18.6)	15.0 (10.6-20.5)
45-day	5.76 (5.03-6.62)	6.65 (5.80-7.66)	8.08 (7.02-9.33)	9.24 (7.98-10.7)	10.8 (9.00-12.9)	12.0 (9.77-14.6)	13.2 (10.4-16.4)	14.3 (10.8-18.4)	15.8 (11.5-21.0)	16.9 (12.0-22.9)
60-day	6.60 (5.78-7.57)	7.60 (6.64-8.72)	9.18 (8.00-10.6)	10.4 (9.06-12.1)	12.1 (10.1-14.4)	13.4 (10.9-16.2)	14.6 (11.5-18.1)	15.7 (11.9-20.2)	17.2 (12.6-22.8)	18.3 (13.0-24.7)

¹ Precipitation frequency (PF) estimates in this table are based on frequency analysis of partial duration series (PDS).

Numbers in parenthesis are PF estimates at lower and upper bounds of the 90% confidence interval. The probability that precipitation frequency estimates (for a given duration and average recurrence interval) will be greater than the upper bound (or less than the lower bound) is 5%. Estimates at upper bounds are not checked against probable maximum precipitation (PMP) estimates and may be higher than currently valid PMP values.

Please refer to NOAA Atlas 14 document for more information.

[Back to Top](#)

PF graphical

PDS-based depth-duration-frequency (DDF) curves
 Latitude: 38.9466°, Longitude: -104.5915°

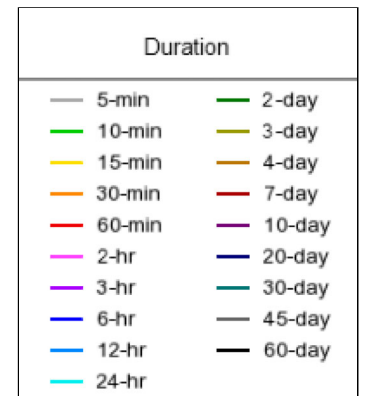
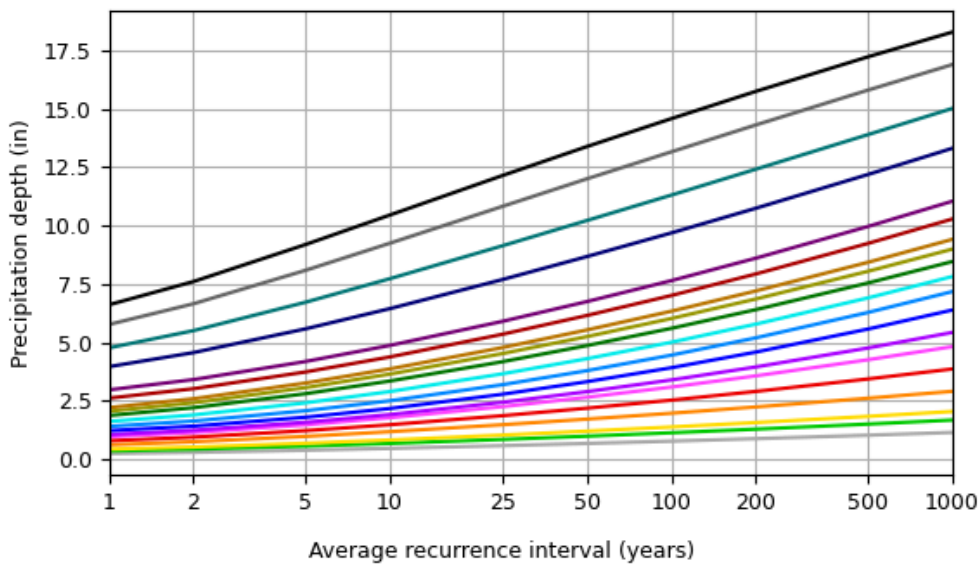
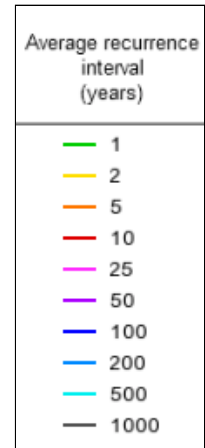
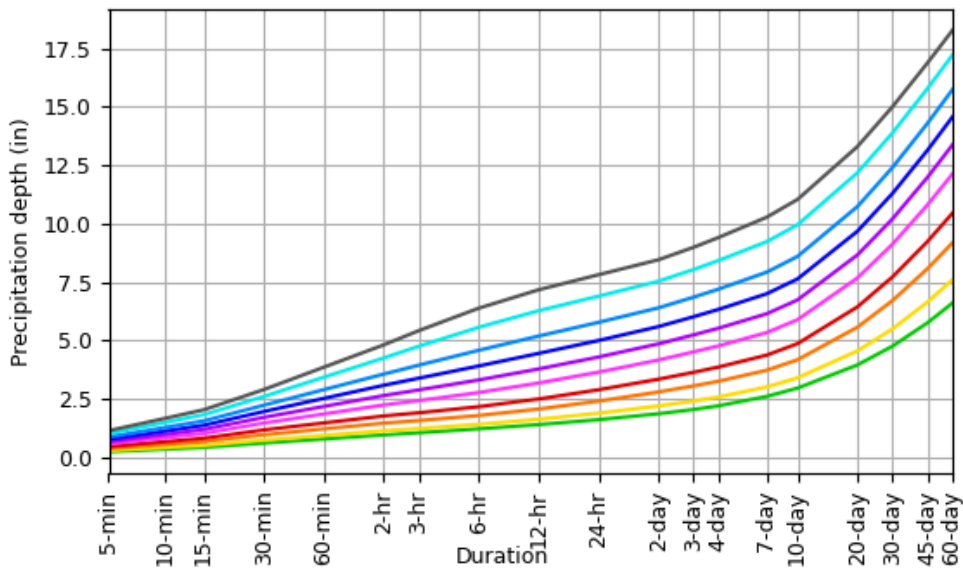

[Back to Top](#)

Maps & aerials

Small scale terrain



Large scale terrain



Large scale map



Large scale aerial

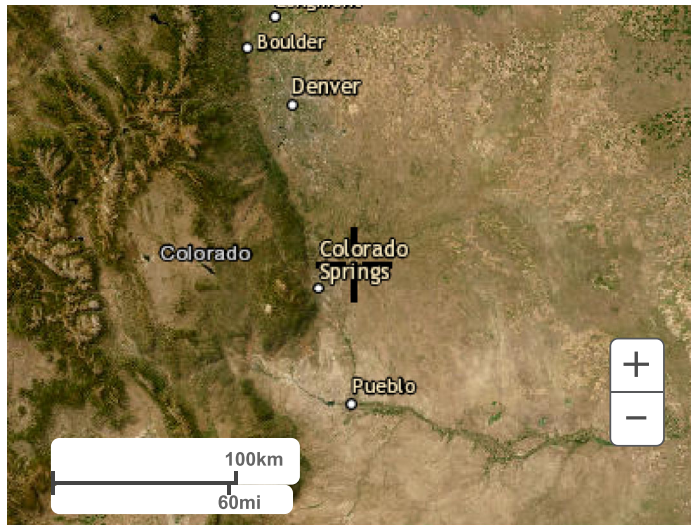

[Back to Top](#)

[US Department of Commerce](#)
[National Oceanic and Atmospheric Administration](#)
[National Weather Service](#)
[National Water Center](#)
1325 East West Highway
Silver Spring, MD 20910
Questions?: HDSC.Questions@noaa.gov

[Disclaimer](#)



Engineering · Planning · Surveying

PROJECT: Ft Smith Rd
 JOB NO.: 35079
 CALC. BY: M Sundstrom
 DATE: 4/9/2024

= FORMULA CELLS
 = USER INPUT CELLS

Project Location	
User Input	▼

IDF Rainfall Data

T _d Minutes	P ₁ : 1-hour Rainfall Depths (inches)	
	Minor Storm	Major Storm
	5-Year	100-Year
	▼	▼
	1.22	2.52
5	4.14	8.55
10	3.30	6.82
20	2.40	4.96
30	1.91	3.95
40	1.61	3.32
50	1.39	2.87
60	1.23	2.55
120	0.76	1.57

Equation 5-1 $I = (28.5 * P_1) / (10 + T_d)^{0.786}$
 I = rainfall intensity (inches per hour)
 P₁ = 1-hour point rainfall depth (inches)
 T_d = storm duration (minutes)

- Reference:
- 1) Urban Drainage and Flood Control District - Urban Storm Drainage Criteria Manual Volume 1, 2017
 - 2) NOAA Atlas 14, Volume 8, Version 2
http://hdsc.nws.noaa.gov/hdsc/pfds/pfds_map_cont.html?bkmrk=co

PROJECT: Ft Smith Rd
 JOB NO.: 35079
 CALC. BY: M Sundstrom
 DATE: 4/9/2024



Impervious Percentages - from Urban Drainage Table 6-3

User Defined	45%	Land Use	0
Residential - 0.25 AC or less	45%	Land Use	0
Land Use	0	Land Use	0
Land Use	0	Land Use	0

SOIL TYPE: (use equation from Table 6-4)

= FORMULA CELLS
 = USER INPUT CELLS

PROPOSED COMPOSITE IMPERVIOUSNESS

Basin	Area (ac)	Weighted Impervious and C Values					Areas (ac)								
		Imp.	C ₂	C ₅	C ₁₀	C ₁₀₀	User Defined	Residential - 0.25 AC or less	Land Use	Land Use	Land Use	Land Use	Land Use	Land Use	
E1	14.23	45%	-	0.41	-	0.50	14.23								

Runoff Coefficients
 obtained from Master
 Drainage Report

STANDARD FORM SF-2
TIME OF CONCENTRATION SUMMARY

Calculated By: M Sundstrom
 Date: 4/9/2024

Project: Ft Smith Rd
 Job No.: 35079
 Checked By: xxxxxxxxxx

SUB-BASIN DATA				INITIAL/OVERLAND TIME (t _i)			TRAVEL TIME (t _t)					t _c CHECK (URBANIZED BASINS)				FINAL t _c	REMARKS
Basin	i	C _s	AREA	LENGTH	SLOPE	t _i	LENGTH	Cv	SLOPE	VEL.	t _t	COMP.	TOT. LENGTH	S _o	tc (Equation 6-5)		
(1)	(2)	(3)	Ac	Ft	%	Min	Ft		%	FPS	Min	t _c	Ft	%	Min	Min	
(4)	(5)	(6)	(7)	(8)	(9)	(10)	(11)	(12)	(13)	(14)	(15)	(16)					
E1	0.45	0.41	14.23	300	2.0	17.17	3,500	7	2.0	0.99	58.93	76.1	3,800	2.00	47.6	47.62	

Equation 6-3 $t_t = ((0.395(1.1 - C_s) \sqrt{L}) / (S_o^{0.33}))$

Equation 6-5 $t_c = (26 - 17i) + (L / (60(14i + 9) \sqrt{S_o}))$

= FORMULA CELLS
 = USER INPUT CELLS

Heavy Meadow	2.5
Tillage/Field	5
Short Pasture and Lawns	7
Nearly Bare Ground	10
Grassed Waterway	15
Paved Areas and Shallow Paved Swales	20

Calculated By: M Sundstrom

Date: 4/9/2024

Checked By: xxxxxxxxxx

5-Year

1-hour rainfall= **1.22**

STANDARD FORM SF-3

STORM DRAINAGE SYSTEM DESIGN
(RATIONAL METHOD PROCEDURE)

Project: Ft Smith Rd

Job No.: 35079

Design Storm: 5-Year

= FORMULA CELLS

= USER INPUT CELLS

BASIN	DIRECT RUNOFF								TOTAL RUNOFF				STREET		PIPE			LENGTH (FT)	VELOCITY (FPS)	t (MIN)	REMARKS
	DESIGN POINT	AREA DESIGN	AREA (AC)	RUNOFF COEFF	t _c (MIN)	C*A (AC)	I (IN/HR)	Q (CFS)	t _c (MIN)	S (C*A) (CA)	I (IN/HR)	Q (CFS)	SLOPE (%)	STREET FLOW	DESIGN FLOW (CFS)	SLOPE (%)	PIPE DIAM. (IN.)				
	(2)	(3)	(4)	(5)	(6)	(7)	(8)	(9)	(10)	(11)	(12)	(13)	(14)	(15)	(16)	(17)	(18)	(19)	(20)	(21)	(22)
E1	E1		14.23	0.41	47.6	5.83	1.44	8.4													

Calculated By: M Sundstrom

Date: 4/9/2024

Checked By: xxxxxxxxxx

100-Year

1-hour rainfall=

2.52

STANDARD FORM SF-3

STORM DRAINAGE SYSTEM DESIGN
(RATIONAL METHOD PROCEDURE)

Project: Ft Smith Rd

Job No.: 35079

Design Storm: 100-Year

= FORMULA CELLS

= USER INPUT CELLS

BASIN	DIRECT RUNOFF								TOTAL RUNOFF				STREET		PIPE			LENGTH (FT)	VELOCITY (FPS)	t (MIN)	REMARKS
	DESIGN POINT	AREA DESIGN	AREA (AC)	RUNOFF COEFF	t _c (MIN)	C*A (AC)	I (IN/HR)	Q (CFS)	t _c (MIN)	S (C*A) (CA)	I (IN/HR)	Q (CFS)	SLOPE (%)	STREET FLOW	DESIGN FLOW (CFS)	SLOPE (%)	PIPE DIAM. (IN.)				
	(2)	(3)	(4)	(5)	(6)	(7)	(8)	(9)	(10)	(11)	(12)	(13)	(14)	(15)	(16)	(17)	(18)	(19)	(20)	(21)	(22)
E1	E1		14.23	0.50	47.6	7.12	2.97	21.1													

PROJECT: Ft Smith Rd
 JOB NO.: 35079
 CALC. BY: M Sundstrom
 DATE: 4/9/2024



RUNOFF SUMMARY								Notes
BASIN LABEL	DESIGN POINT	AREA	Imp.	C5	C100	LOCAL (CFS)		
						Q5	Q100	
E1	E1	14.23	0.45	0.41	0.50	8.4	21.1	

= FORMULA CELLS
 = USER INPUT CELLS

Worksheet for Section 0+25 - 5yr

Project Description	
Friction Method	Manning Formula
Solve For	Normal Depth
Input Data	
Channel Slope	0.002 ft/ft
Discharge	8.40 cfs

Section Definitions

Station (ft)	Elevation (ft)
0+00	6,881.80
0+19	6,877.92
0+25	6,878.25
0+30	6,881.33

Roughness Segment Definitions

Start Station	Ending Station	Roughness Coefficient
(0+00, 6,881.80)	(0+30, 6,881.33)	0.045

Options

Current Roughness Weighted Method	Pavlovskii's Method
Open Channel Weighting Method	Pavlovskii's Method
Closed Channel Weighting Method	Pavlovskii's Method

Results

Normal Depth	12.0 in
Roughness Coefficient	0.045
Elevation	6,878.92 ft
Elevation Range	6,877.9 to 6,881.8 ft
Flow Area	7.7 ft ²
Wetted Perimeter	12.2 ft
Hydraulic Radius	7.6 in
Top Width	11.89 ft
Normal Depth	12.0 in
Critical Depth	6.1 in
Critical Slope	0.044 ft/ft
Velocity	1.09 ft/s
Velocity Head	0.02 ft
Specific Energy	1.01 ft
Froude Number	0.238
Flow Type	Subcritical

Worksheet for Section 0+25 - 5yr

GVF Input Data

Downstream Depth	0.0 in
Length	0.0 ft
Number Of Steps	0

GVF Output Data

Upstream Depth	0.0 in
Profile Description	N/A
Profile Headloss	0.00 ft
Downstream Velocity	0.00 ft/s
Upstream Velocity	0.00 ft/s
Normal Depth	12.0 in
Critical Depth	6.1 in
Channel Slope	0.002 ft/ft
Critical Slope	0.044 ft/ft

Cross Section for Section 0+25 - 5yr

Project Description	
Friction Method	Manning Formula
Solve For	Normal Depth
Input Data	
Channel Slope	0.002 ft/ft
Normal Depth	12.0 in
Discharge	8.40 cfs

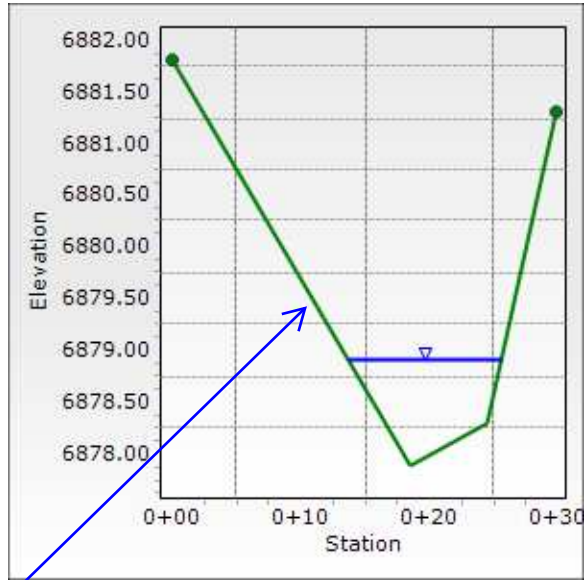

Please label all slopes
(typ throughout the report)
Side slopes for
grass-lined channels shall
be no steeper than 4H:1V

Worksheet for Section 0+75 - 5yr

Project Description	
Friction Method	Manning Formula
Solve For	Normal Depth
Input Data	
Channel Slope	0.002 ft/ft
Discharge	8.40 cfs

Section Definitions

Station (ft)	Elevation (ft)
0+00	6,881.73
0+21	6,878.37
0+46	6,877.75
0+83	6,879.87
1+02	6,881.84

Roughness Segment Definitions

Start Station	Ending Station	Roughness Coefficient
(0+00, 6,881.73)	(1+02, 6,881.84)	0.045

Options

Current Roughness Weighted Method	Pavlovskii's Method
Open Channel Weighting Method	Pavlovskii's Method
Closed Channel Weighting Method	Pavlovskii's Method

Results

Normal Depth	7.7 in
Roughness Coefficient	0.045
Elevation	6,878.39 ft
Elevation Range	6,877.8 to 6,881.8 ft
Flow Area	11.9 ft ²
Wetted Perimeter	36.3 ft
Hydraulic Radius	3.9 in
Top Width	36.26 ft
Normal Depth	7.7 in
Critical Depth	4.2 in
Critical Slope	0.053 ft/ft
Velocity	0.70 ft/s
Velocity Head	0.01 ft
Specific Energy	0.65 ft
Froude Number	0.216
Flow Type	Subcritical

Worksheet for Section 0+75 - 5yr

GVF Input Data

Downstream Depth	0.0 in
Length	0.0 ft
Number Of Steps	0

GVF Output Data

Upstream Depth	0.0 in
Profile Description	N/A
Profile Headloss	0.00 ft
Downstream Velocity	0.00 ft/s
Upstream Velocity	0.00 ft/s
Normal Depth	7.7 in
Critical Depth	4.2 in
Channel Slope	0.002 ft/ft
Critical Slope	0.053 ft/ft

Cross Section for Section 0+75 - 5yr

Project Description	
Friction Method	Manning Formula
Solve For	Normal Depth

Input Data	
Channel Slope	0.002 ft/ft
Normal Depth	7.7 in
Discharge	8.40 cfs

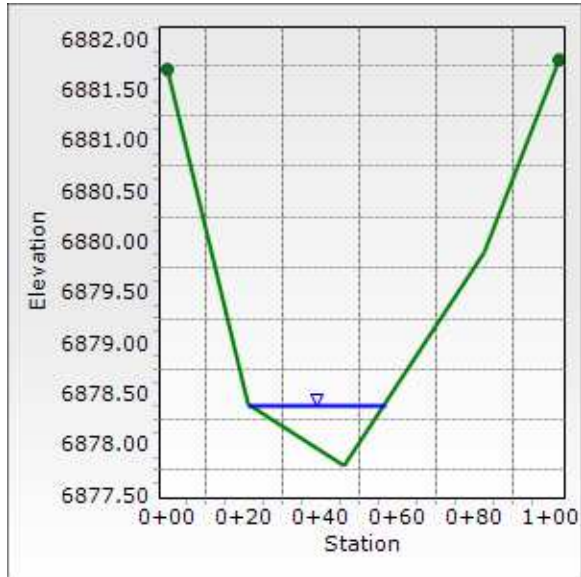

Worksheet for Section 0+25 - 100yr

Project Description	
Friction Method	Manning Formula
Solve For	Normal Depth
Input Data	
Channel Slope	0.002 ft/ft
Discharge	21.10 cfs

Section Definitions

Station (ft)	Elevation (ft)
0+00	6,881.80
0+19	6,877.92
0+25	6,878.25
0+30	6,881.33

Roughness Segment Definitions

Start Station	Ending Station	Roughness Coefficient
(0+00, 6,881.80)	(0+30, 6,881.33)	0.045

Options

Current Roughness Weighted Method	Pavlovskii's Method
Open Channel Weighting Method	Pavlovskii's Method
Closed Channel Weighting Method	Pavlovskii's Method

Results

Normal Depth	18.3 in
Roughness Coefficient	0.045
Elevation	6,879.44 ft
Elevation Range	6,877.9 to 6,881.8 ft
Flow Area	14.9 ft ²
Wetted Perimeter	15.8 ft
Hydraulic Radius	11.3 in
Top Width	15.33 ft
Normal Depth	18.3 in
Critical Depth	9.3 in
Critical Slope	0.038 ft/ft
Velocity	1.42 ft/s
Velocity Head	0.03 ft
Specific Energy	1.55 ft
Froude Number	0.254
Flow Type	Subcritical

Worksheet for Section 0+25 - 100yr

GVF Input Data

Downstream Depth	0.0 in
Length	0.0 ft
Number Of Steps	0

GVF Output Data

Upstream Depth	0.0 in
Profile Description	N/A
Profile Headloss	0.00 ft
Downstream Velocity	0.00 ft/s
Upstream Velocity	0.00 ft/s
Normal Depth	18.3 in
Critical Depth	9.3 in
Channel Slope	0.002 ft/ft
Critical Slope	0.038 ft/ft

Cross Section for Section 0+25 - 100yr

Project Description	
Friction Method	Manning Formula
Solve For	Normal Depth

Input Data	
Channel Slope	0.002 ft/ft
Normal Depth	18.3 in
Discharge	21.10 cfs

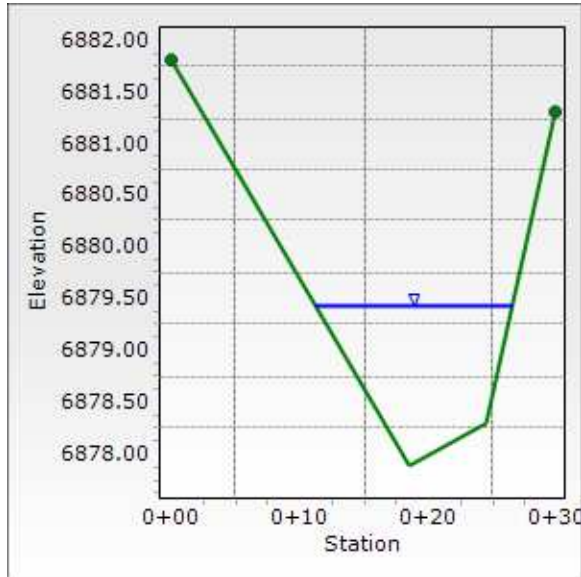

Worksheet for Section 0+75 - 100yr

Project Description	
Friction Method	Manning Formula
Solve For	Normal Depth
Input Data	
Channel Slope	0.002 ft/ft
Discharge	21.10 cfs

Section Definitions

Station (ft)	Elevation (ft)
0+00	6,881.73
0+21	6,878.37
0+46	6,877.75
0+83	6,879.87
1+02	6,881.84

Roughness Segment Definitions

Start Station	Ending Station	Roughness Coefficient
(0+00, 6,881.73)	(1+02, 6,881.84)	0.045

Options

Current Roughness Weighted Method	Pavlovskii's Method
Open Channel Weighting Method	Pavlovskii's Method
Closed Channel Weighting Method	Pavlovskii's Method

Results

Normal Depth	10.8 in
Roughness Coefficient	0.045
Elevation	6,878.65 ft
Elevation Range	6,877.8 to 6,881.8 ft
Flow Area	22.1 ft ²
Wetted Perimeter	42.4 ft
Hydraulic Radius	6.2 in
Top Width	42.37 ft
Normal Depth	10.8 in
Critical Depth	6.1 in
Critical Slope	0.047 ft/ft
Velocity	0.96 ft/s
Velocity Head	0.01 ft
Specific Energy	0.92 ft
Froude Number	0.233
Flow Type	Subcritical

Worksheet for Section 0+75 - 100yr

GVF Input Data

Downstream Depth	0.0 in
Length	0.0 ft
Number Of Steps	0

GVF Output Data

Upstream Depth	0.0 in
Profile Description	N/A
Profile Headloss	0.00 ft
Downstream Velocity	0.00 ft/s
Upstream Velocity	0.00 ft/s
Normal Depth	10.8 in
Critical Depth	6.1 in
Channel Slope	0.002 ft/ft
Critical Slope	0.047 ft/ft

Cross Section for Section 0+75 - 100yr

Project Description	
Friction Method	Manning Formula
Solve For	Normal Depth

Input Data	
Channel Slope	0.002 ft/ft
Normal Depth	10.8 in
Discharge	21.10 cfs

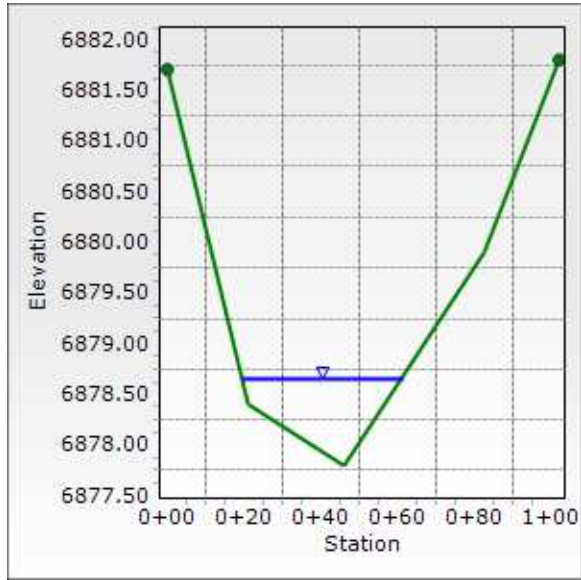

Appendix C

Excerpts from Master Drainage Report

**FINAL DRAINAGE &
EROSION CONTROL REPORT FOR
WOODMEN HILLS SUBDIVISION FILING 9,
FALCON, EL PASO COUNTY, COLORADO**

October 19, 1999

Prepared for:

**FALCON PROPERTIES AND INVESTMENTS, LLP
11720 Woodmen Hills Drive
Falcon, CO 80831**

Prepared by:

**URS GREINER WOODWARD CLYDE
8415 EXPLORER DR, SUITE 110
COLORADO SPRINGS, CO 80920**

URSGWC Project No. 67-00042363

CERTIFICATIONS

Engineer's Statement:

The attached drainage plan and report were prepared under my direction and supervision and are correct to the best of my knowledge and belief. Said drainage report has been prepared according to the criteria established by the City/County for drainage reports and said report is in conformity with the master plan of the drainage basin. I accept responsibility for any liability caused by any negligent acts, errors or omissions on my part in preparing this report.

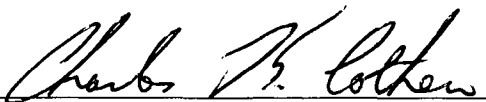

Charles K. Cothern, PE # 24997

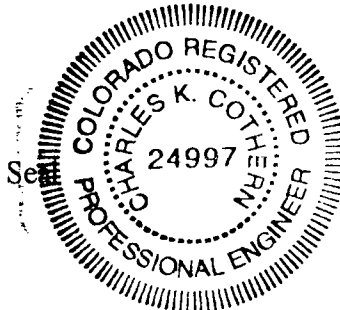

Developer's Statement:

I, the developer have read and will comply with all of the requirements specified in this drainage report and plan.

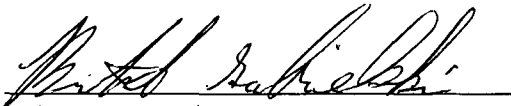

Falcon Properties & Investments, LLC.

By: Butch Gabrielski

Title: Land Development Mgr.

Address: 11720 Woodmen Hills Dr.
Falcon, CO 80831

El Paso County's Statement

Filed in accordance with Section 51.1 of the El Paso Land Development Code, as amended.

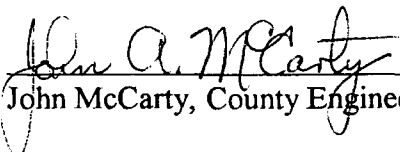
John McCarty, County Engineer/Director

12-14-99
Date

Conditions:

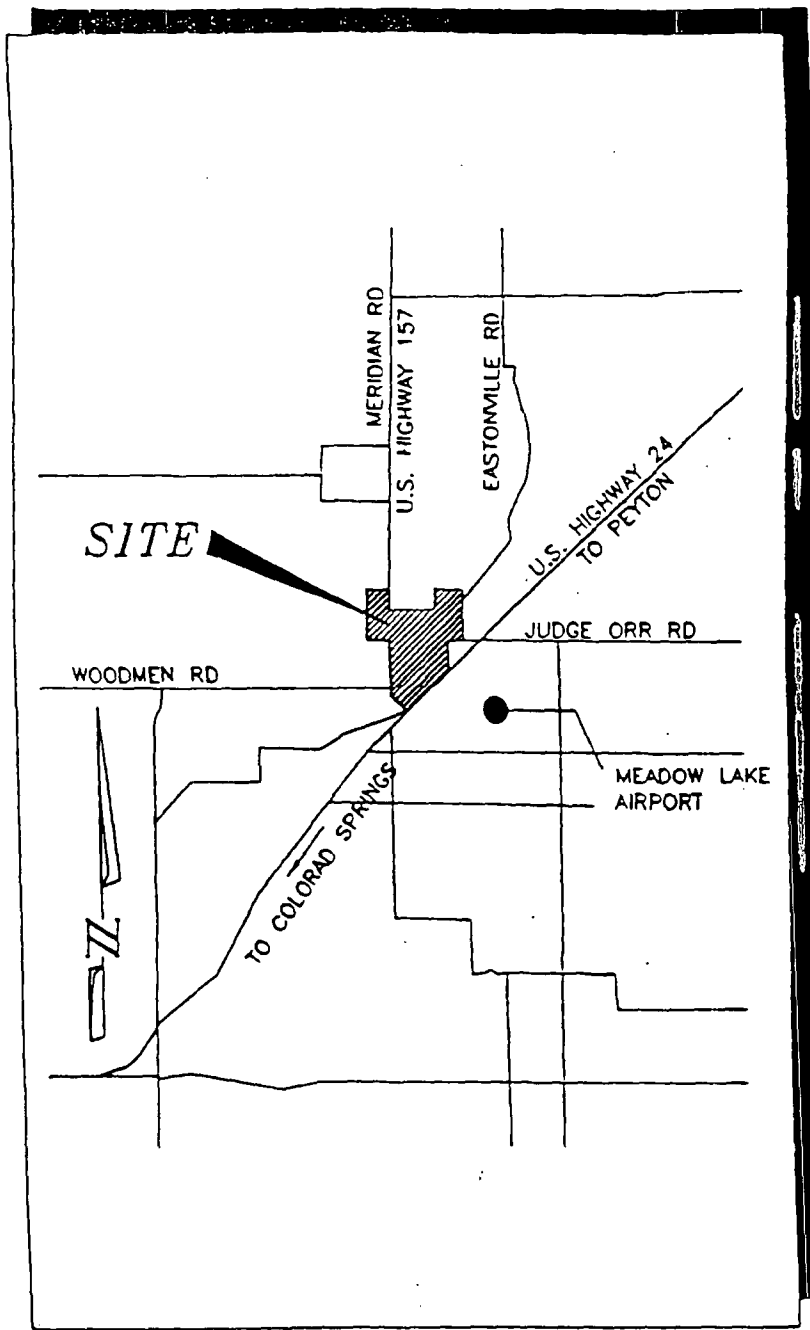

VICINITY MAP
N.T.S.

Fig 1 - dmap of 12/2/98

URS Greiner Woodward Clyde
8415 Explorer Dr, Suite 110
Colorado Springs, CO 80915
719.531.0001 fax: 719.531.0007

VICINITY MAP

FIGURE
1

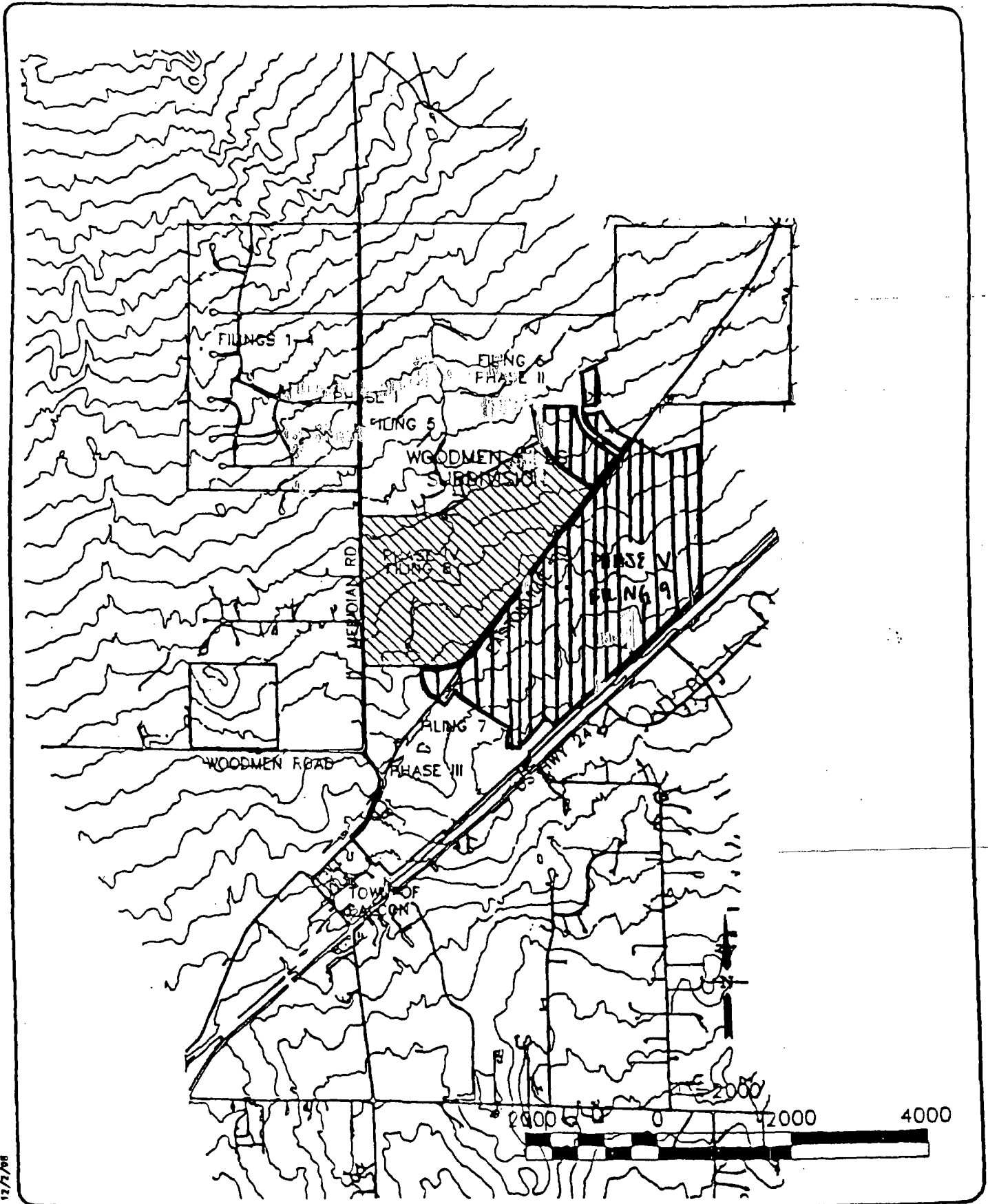

Fig 2 - SUBDIVISION.dwg 12/7/98

U'S Breiner Woodward Clyde

8415 Explorer Dr, Suite 110
 Colorado Springs, CO 80915
 719.531.0001 fax 719.531.0007

PROJ NO. 8742238.08

WOODMEN HILLS SUBDIVISION

FIGURE

2

JCHHS PAT

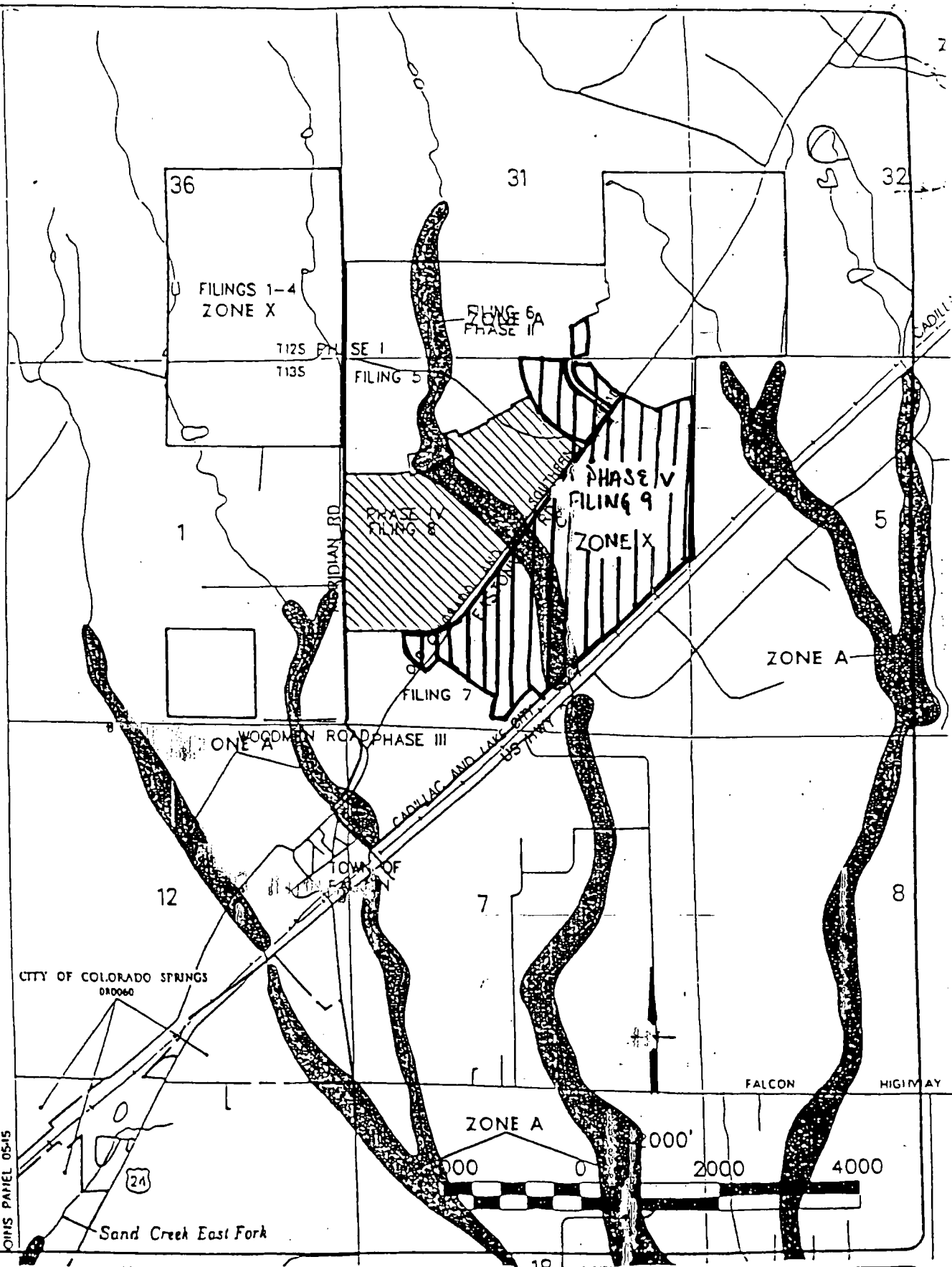

11/7/98

843-REUAmop.dwg dr

URS Greiner Woodward Clyde
 8415 Explorer Dr, Suite 110
 Colorado Springs, CO 80915
 719.531.0001 fax: 719.531.0007
 PROJ NO. 8742238.08

**WOODMEN HILLS SUBDIVISION
 FEMA FLOOD INSURANCE RATE MAP**

**FIGURE
 3**

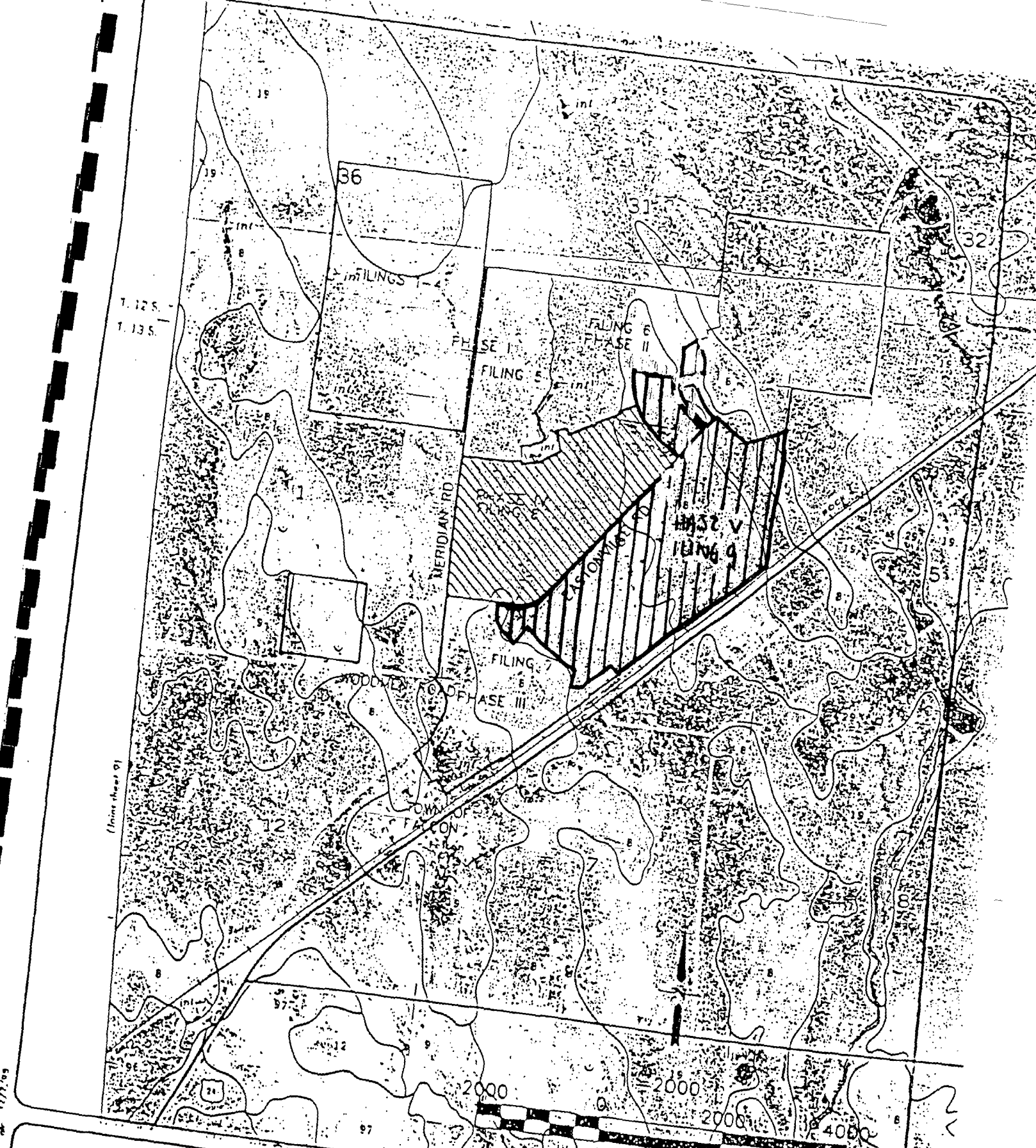

URS Bralner Woodward Clyde
 8415 Explorer Dr. Suite 110
 Colorado Springs, CO 80915
 719.531.0001 fax: 719.531.0007

WOODMEN HILLS SUBDIVISION SOILS MAP

FIGURE
 4

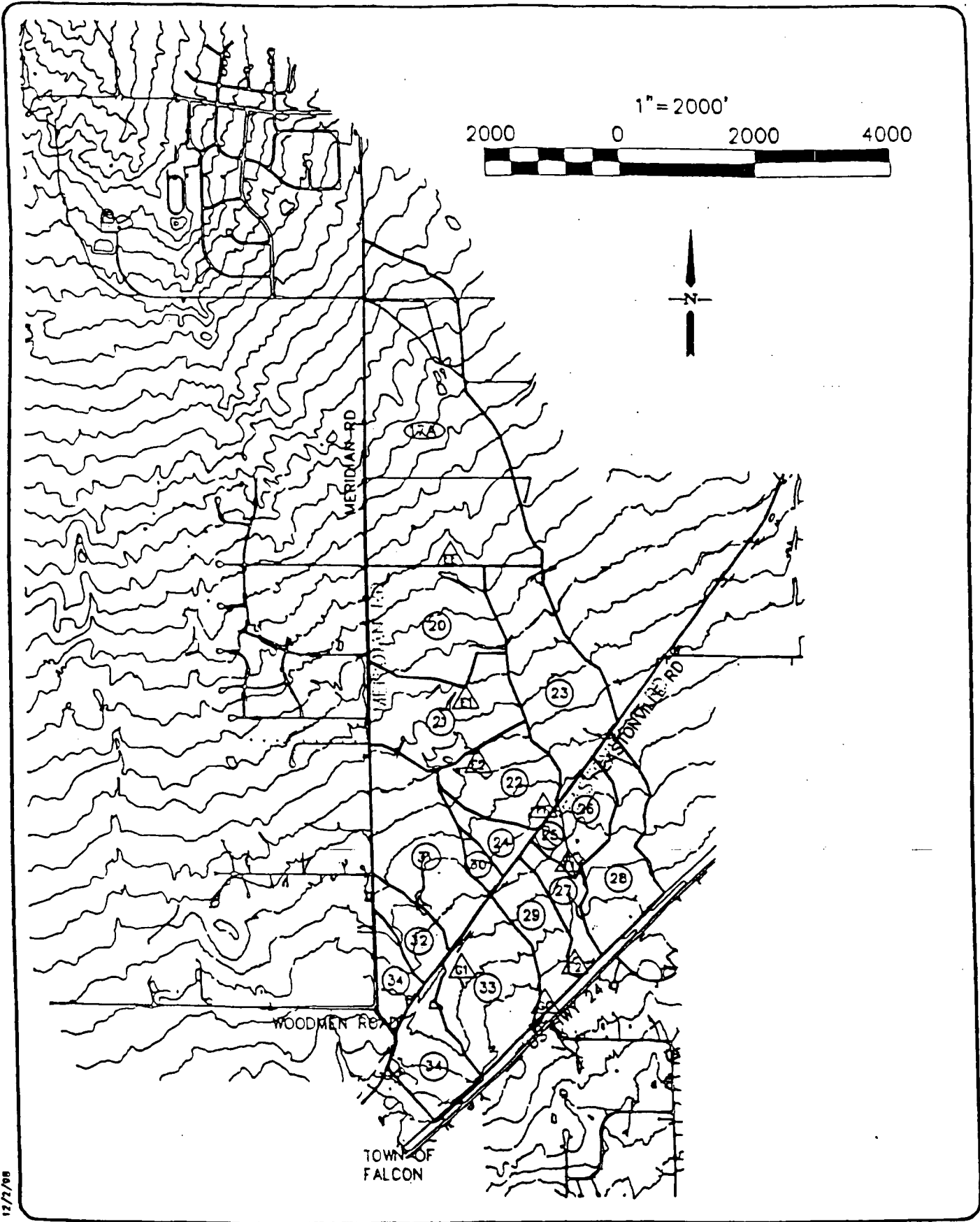

045-182838.dwg dr 12/7/98

URS Brener Woodward Clyde

8415 Explorer Dr, Suite 110
 Colorado Springs, CO 80915
 719.531.0001 fax 719.531.0007

WOODMEN HILLS SUBDIVISION HISTORIC BASINS

FIGURE

5

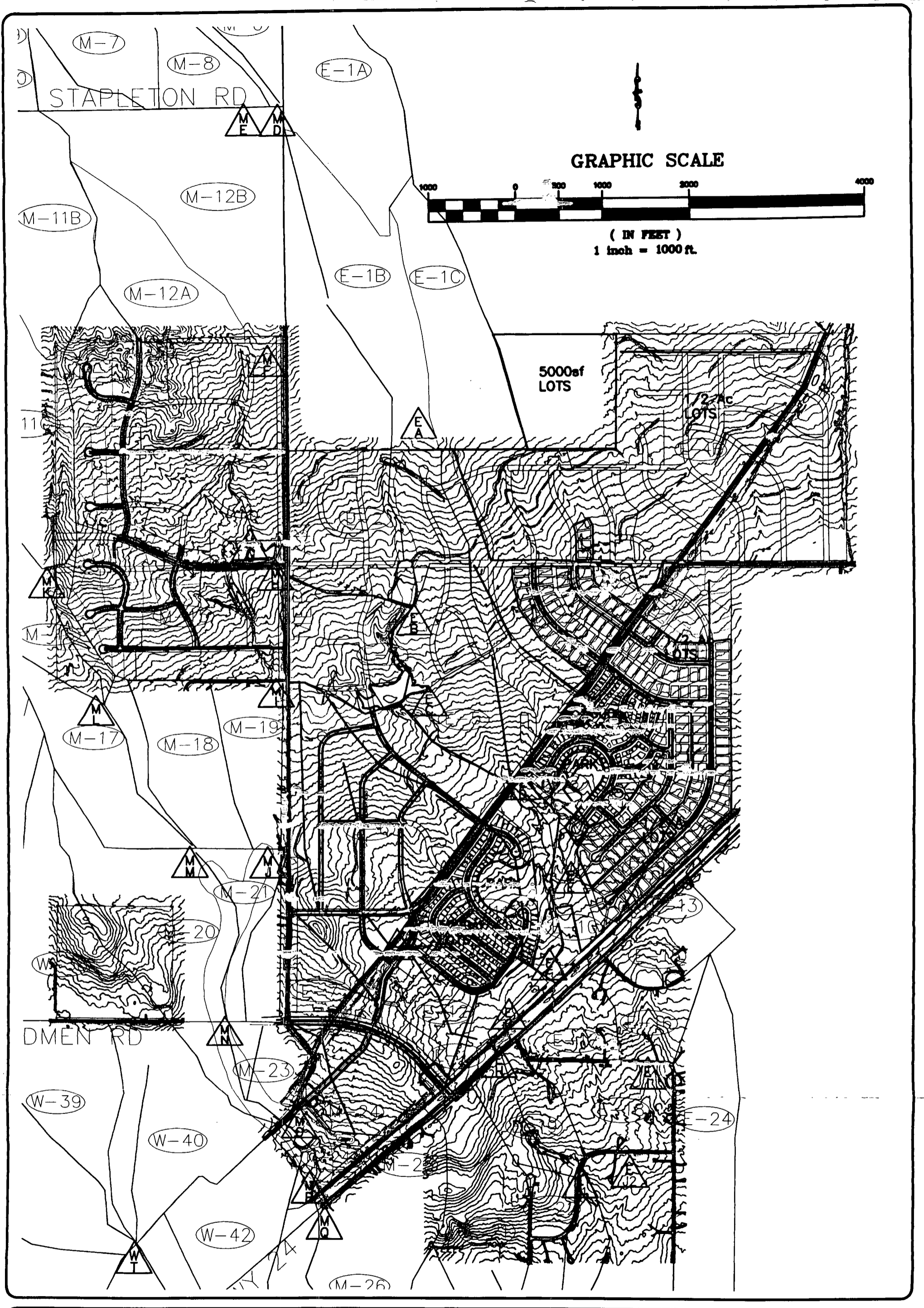

URS Greiner Woodward Clyde

8415 Explorer Dr, Suite 110
 Colorado Springs, CO 80915
 719.531.0001 fax: 719.531.0007

PROJ NO. 6742363.09

**WOODMEN HILLS SUBDIVISION
 DEVELOPED CONDITION BASINS**

FIGURE

6

FINAL DRAINAGE PLAN SHEET 1 OF 2

WOODMEN HILLS SUBDIVISION FILING No. 9

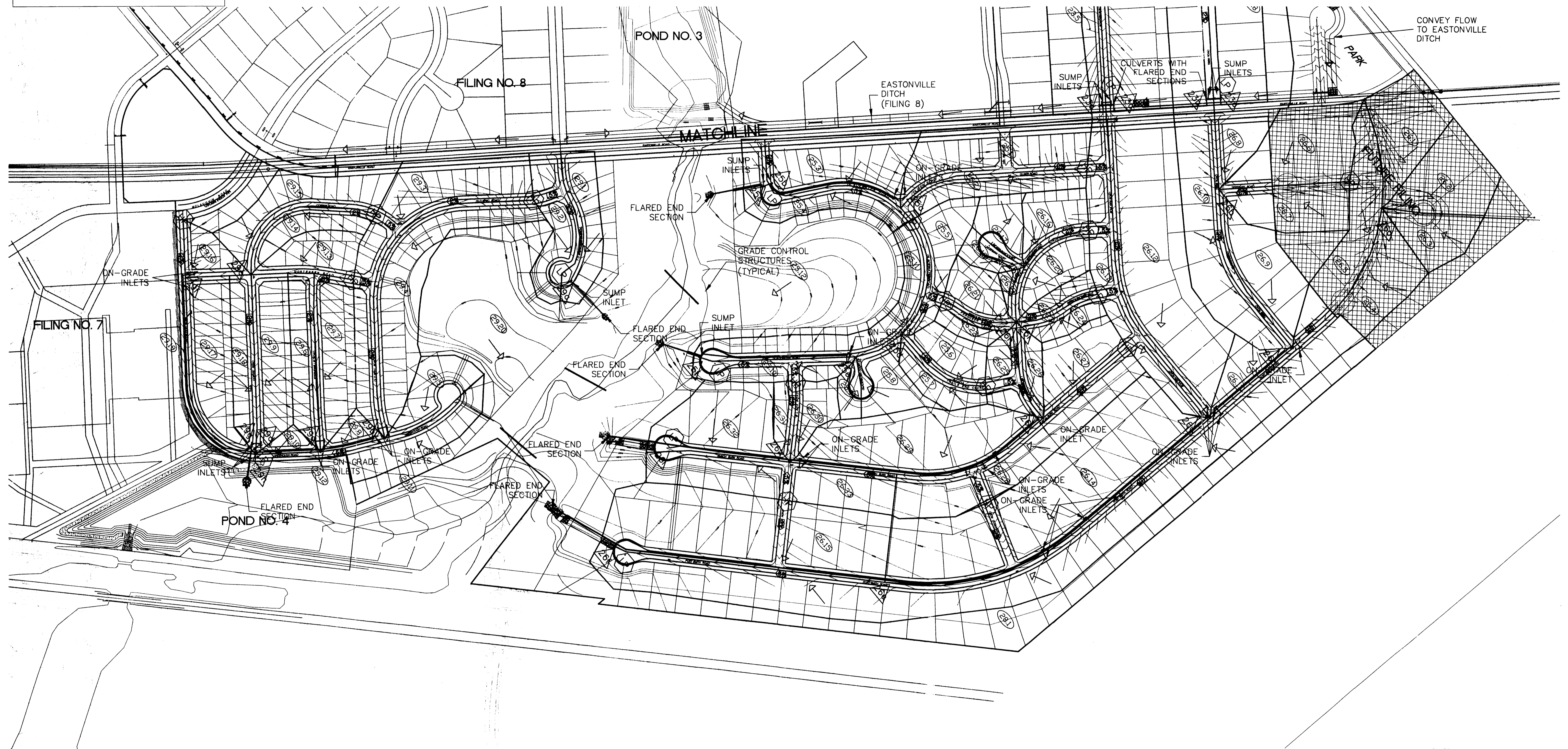
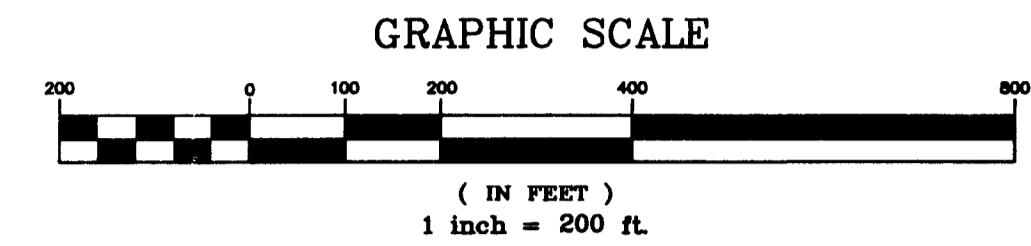
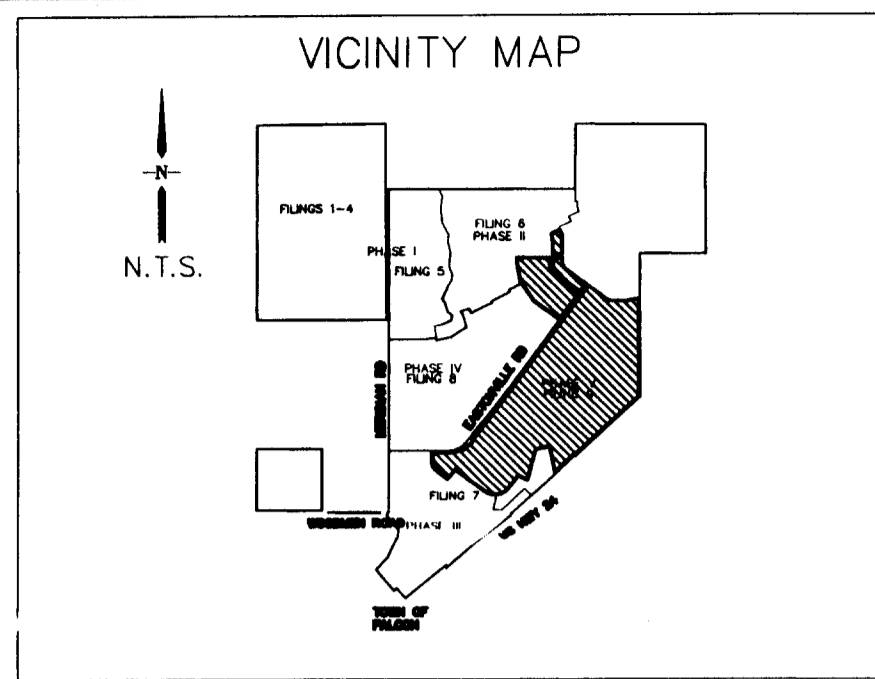

LEGEND

(25.12)

SUB-BASIN



FLOW DIRECTION

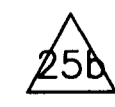

DESIGN POINTS



HIGH POINT / LOW POINT



ESTIMATED STREET SLOPE

WOODMEN HILLS
ROOM TO GROW

URS Greiner Woodward Clyde

8415 EXPLORER DRIVE, STE 110
COLORADO SPRINGS, CO 80920
(719) 531-0001

SHEET 1 OF 2

\\ur-ws16716742363\CD\Filing 9\drainage\FINAL.dwg Thu Oct 26 16:42:18 1999 Plotted by EDE

FINAL DRAINAGE PLAN SHEET 2 OF 2 WOODMEN HILLS SUBDIVISION FILING No. 9

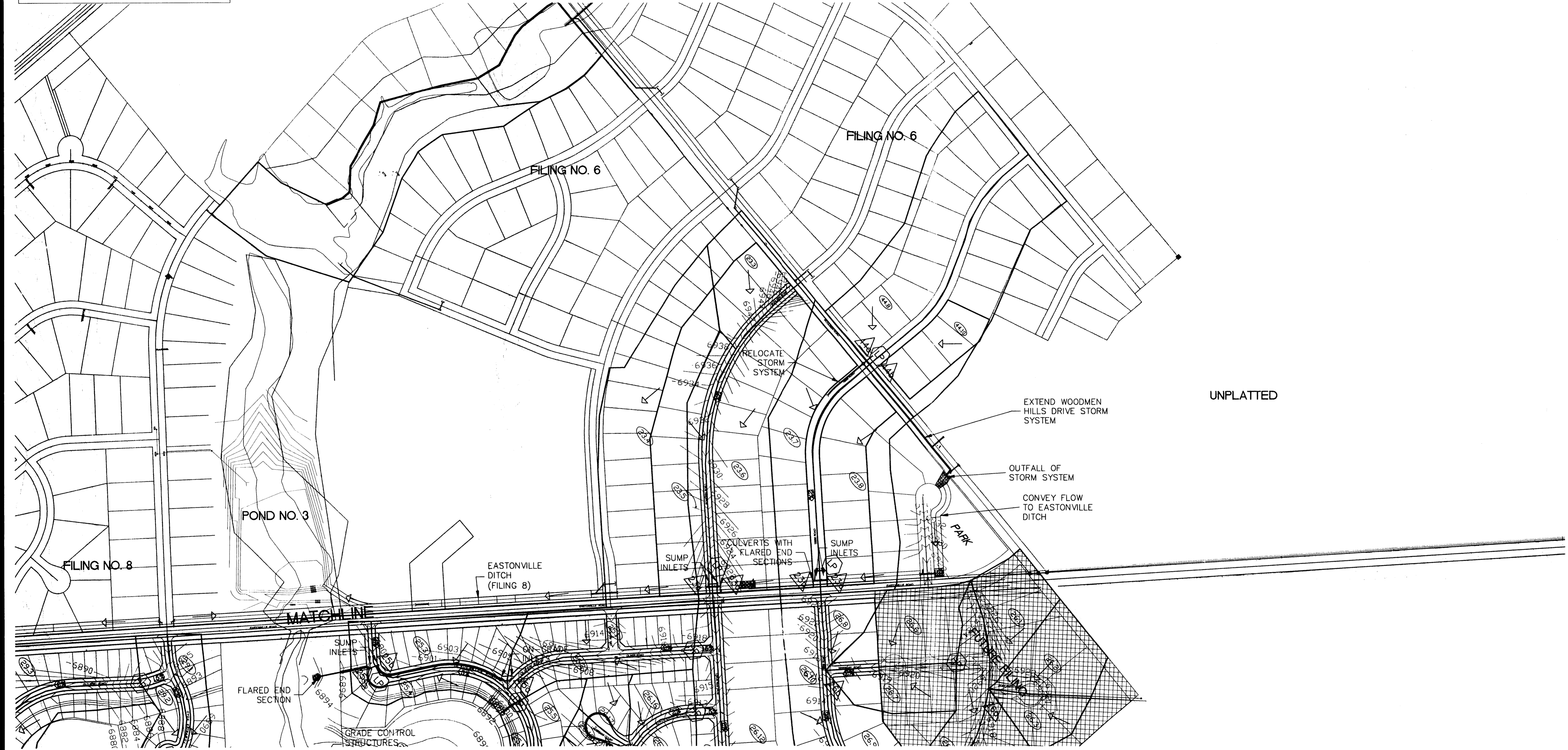
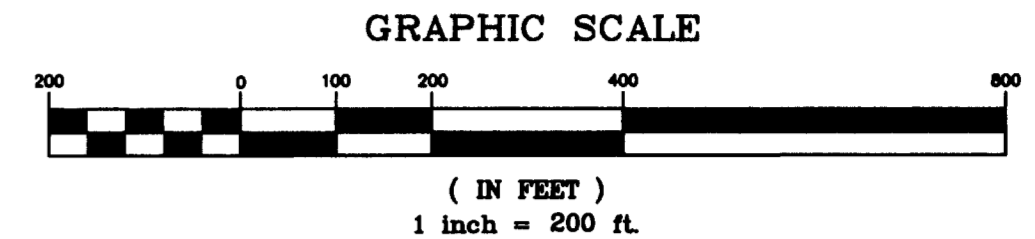
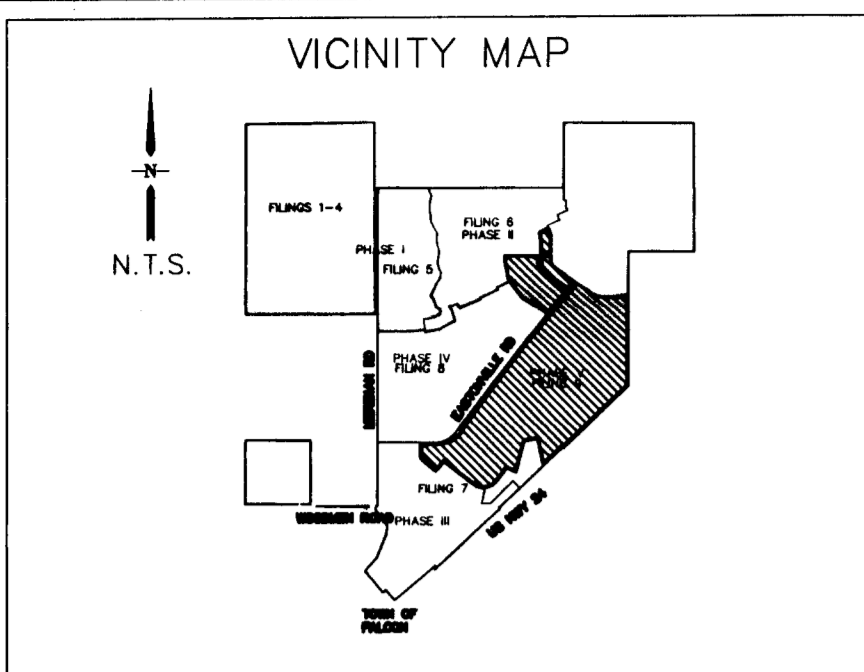

UNPLATTED

LEGEND

- | | | |
|----------------|------------------------|------------------------|
| SUB-BASIN | DESIGN POINTS | ESTIMATED STREET SLOPE |
| FLOW DIRECTION | HIGH POINT / LOW POINT | |

WOODMEN HILLS
ROOM TO GROW

URS Greiner Woodward Clyde
8415 EXPLORER DRIVE, STE 110
COLORADO SPRINGS, CO 80920
(719) 531-0001
SHEET 2 OF 2

Appendix D

Drainage Plans

R:\35079CS Ft. Smith Rd Drainage Letter\Drawings\Drawings\Drawings\35079CS_Overall Drainage Map.dwg, 4/11/2024 9:14:31 AM, Mark Sundstrom



LEGEND

EXISTING LINETYPES
 81
 -5280-

PROPOSED LINETYPES
 81
 -5280-

MINOR CONTOUR (1' INTERVAL)
 MAJOR CONTOUR (5' INTERVAL)
 DRAINAGE BOUNDARY

EXISTING SYMBOLS
 →

PROPOSED SYMBOLS
 →

FLOW DIRECTION

DESIGN POINT DESIGNATION
 A = BASIN DESIGNATION
 B = BASIN AREA (ac)
 C = 100-YR C-FACTOR
 D = 5-YR C-FACTOR

RUNOFF SUMMARY							
BASIN LABEL	DESIGN POINT	AREA	Imp.	C5	C100	LOCAL (CFS)	
						Q5	Q100
E1	E1	14.23	0.45	0.41	0.50	8.4	21.1

BASELINE
 Engineering - Planning - Surveying
 1046 ELKTON DRIVE • COLORADO SPRINGS, COLORADO 80907
 P. 719.531.6200 • F. 719.531.6266 • www.baselinecorp.com

DESIGNED BY: MAS
 DRAWN BY: LAR
 CHECKED BY: NJN

PREPARED BY: DATE:

REVISION DESCRIPTION:

TOWN OF PEYTON
 EL PASO COUNTY
JEROME ENGEL
 FT SMITH RD DRAINAGE LETTER
 7981 FORT SMITH RD
 OVERALL DRAINAGE PLAN

PREPARED UNDER THE DIRECT SUPERVISION OF

FOR AND ON BEHALF OF	BASELINE CORPORATION
INITIAL SUBMITTAL	XX/XX/XX
DRAWING SIZE	24" X 36"
SURVEY FIRM	SURVEY DATE
BEC	XX/XX/XX
JOB NO.	C35079CS
DRAWING NAME	35079CS_Overall Drainage Map.dwg
SHEET	OF XX

1
 D1

GRAPHIC SCALE
 0 10 20
 (IN FEET)
 1 INCH = 10 FT

OVERALL DRAINAGE PLAN

R:\35079CS FT Smith Rd Drainage Letter\Drawings\Drainage Maps.dwg, 4/11/2024 9:09:29 AM, Mark Sundstrom

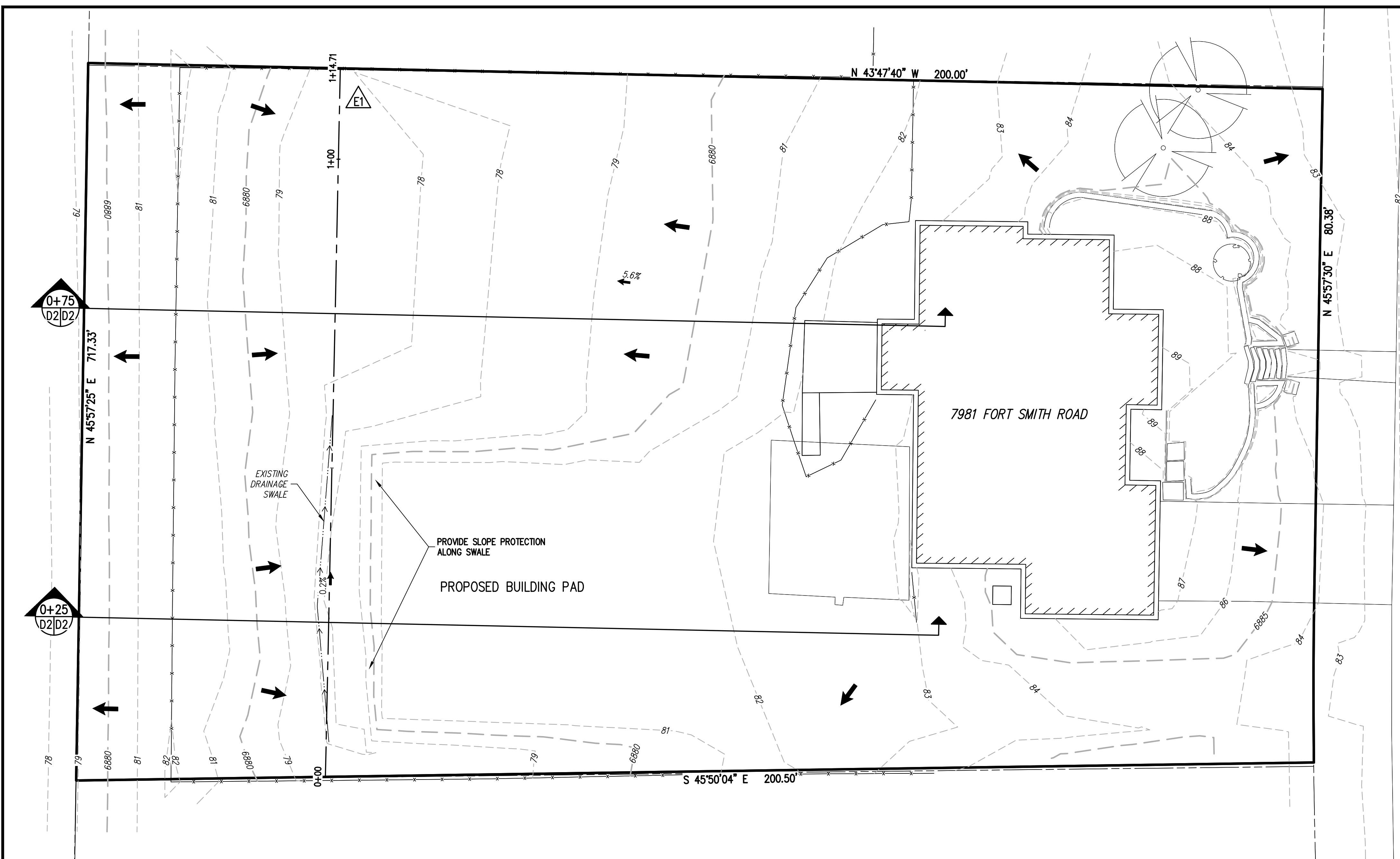

LEGEND

EXISTING LINETYPES	PROPOSED LINETYPES	
81	81	MINOR CONTOUR (1' INTERVAL)
5280	5280	MAJOR CONTOUR (5' INTERVAL)
(Solid line)	(Solid line)	PROPERTY BOUNDARY
(Dashed line)	(Dashed line)	LOT LINE
(Dashed line)	(Dashed line)	EDGE OF ASPHALT
(Dashed line)	(Dashed line)	EDGE OF GRAVEL
(Dashed line)	(Dashed line)	WIRE FENCE
(Dashed line)	(Dashed line)	EDGE OF BUILDING
(Dashed line)	(Dashed line)	DITCH FLOWLINE
(Dashed line)	(Dashed line)	DRAINAGE BOUNDARY

EXISTING SYMBOLS: PROPOSED SYMBOLS: FLOW DIRECTION, TYPICALLY ON PAVED SURFACES

DESIGN POINT DESIGNATION: A = BASIN DESIGNATION, B = BASIN AREA (ac), C = 100-YR C-FACTOR, D = 5-YR C-FACTOR

RUNOFF SUMMARY

BASIN LABEL	DESIGN POINT	AREA	Imp.	C5	C100	LOCAL (CFS)	
						Q5	Q100
E1	E1	14.23	0.45	0.41	0.50	8.4	21.1

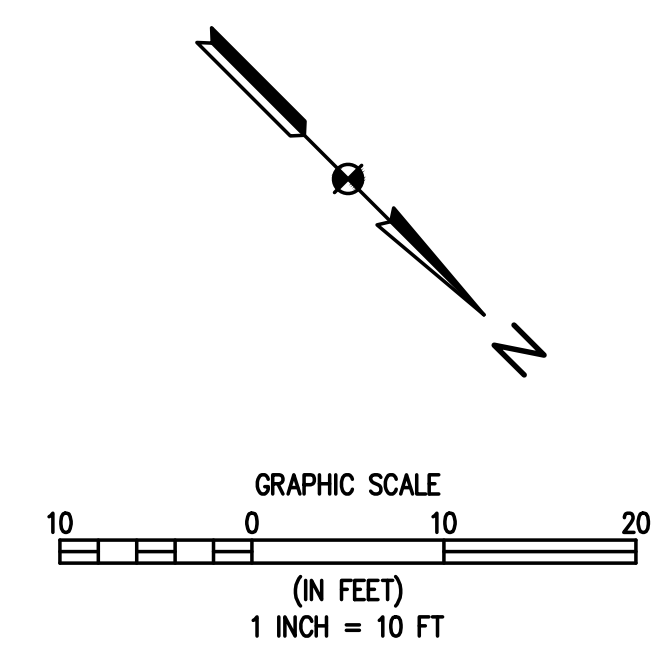
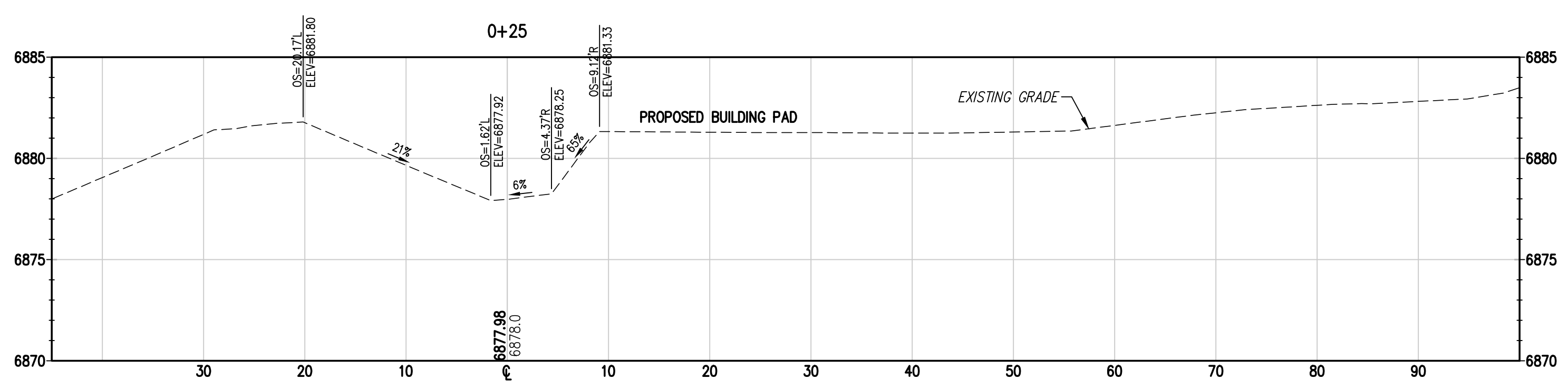
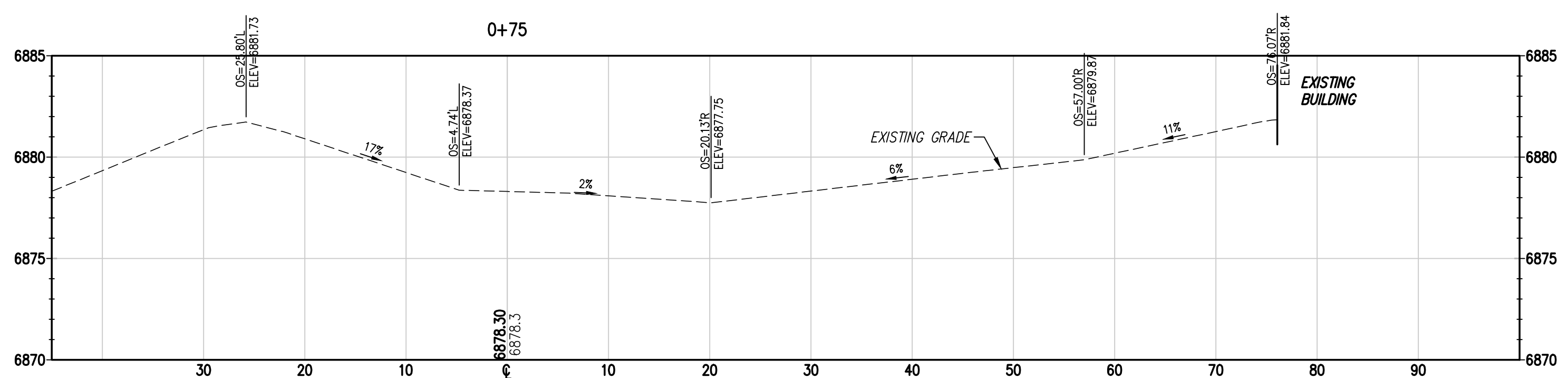

1
D2
PROPOSED DRAINAGE PLAN

BASELINE
Engineering - Planning - Surveying
1046 ELKTON DRIVE • COLORADO SPRINGS, COLORADO 80907
P. 719.531.6200 • F. 719.531.6266 • www.baselinecorp.com

DESIGNED BY	MAS	DATE	
DRAWN BY	LAR	REVISION DESCRIPTION	
CHECKED BY	NUN	PREPARED BY	

TOWN OF PEYTON
EL PASO COUNTY
JEROME ENGEL
FT SMITH RD DRAINAGE LETTER
7981 FORT SMITH RD
PROPOSED DRAINAGE PLAN

FOR AND ON BEHALF OF
BASELINE CORPORATION

INITIAL SUBMITTAL	XX/XX/XX
DRAWING SIZE	24" X 36"
SURVEY FIRM	XX/XX/XX
SURVEY DATE	XX/XX/XX
JOB NO.	C35079CS
DRAWING NAME	35079CS_Drainage Maps.dwg
SHEET	2 OF XX

D2