



# FINAL DRAINAGE LETTER

**7981 Fort Smith Road  
Peyton, CO 80831**

LOT 593 WOODMEN HILLS FILING NO. 9  
LOCATED IN SECTION 6, T 13 S, R 64 W OF THE 6TH PM  
EL PASO COUNTY, STATE OF COLORADO

Prepared For:  
Jerome Engel  
7981 Fort Smith Road  
Peyton, CO 80831

Prepared By:  
**Baseline Engineering Corporation**  
1046 Elkton Drive  
Colorado Springs, Colorado 80907

Mark Sundstrom, PE  
Steve Baggs, PE  
JOB # 35079CS

---

**Original Submittal: April 10, 2024**

 **BASELINE**

Engineering · Planning · Surveying



## Table of Contents

Certification Statements .....	3
Engineer’s Statement.....	3
Developer’s Statement .....	3
El Paso County Certification.....	3
Introduction .....	4
Description of Project .....	4
Scope and Purpose of Report .....	4
Existing Drainage System .....	4
Proposed Drainage System .....	5
Conclusions .....	6
References .....	7
APPENDIX.....	8
Appendix A.....	9
Appendix B .....	10
Appendix C .....	11
Appendix D.....	12

## Certification Statements

### Engineer's Statement

The attached drainage plan and report were prepared under my direction and supervision and are correct to the best of my knowledge and belief. Said drainage report has been prepared according to the criteria established by the County for drainage reports and said report is in conformity with the applicable master plan of the drainage basin. I accept responsibility for any liability caused by any negligent acts, errors or omissions on my part in preparing this report.

\_\_\_\_\_  
Mark Sundstrom, P.E. Colorado 56102

### Developer's Statement

I, the developer have read and will comply with all of the requirements specified in this drainage report and plan.

Name of Developer: \_\_\_\_\_

Authorized Signature/Date: \_\_\_\_\_

Printed Name: \_\_\_\_\_

Title: \_\_\_\_\_

Address: \_\_\_\_\_

### El Paso County Certification

Filed in accordance with the requirements of the Drainage Criteria Manual, Volumes 1 and 2, El Paso County Engineering Criteria Manual and Land Development Code as amended.

\_\_\_\_\_  
County Engineer / ECM Administrator

\_\_\_\_\_  
Date

# Introduction

## Description of Project

The subject property is located at 7981 Fort Smith Road in unincorporated El Paso County. It is legally known as Lot 593 of Woodmen Hills Filing No. 9. The proposed project includes construction of a RV garage on the north side of the existing single-family dwelling. The proposed garage adds approximately 1,800 sf of impervious area. The total disturbed area is approximately 4,000 sf.

## Scope and Purpose of Report

The purpose of this letter is to demonstrate that the proposed improvements do not negatively impact the adjacent properties. It also supports a Plat Note Waiver action that will remove the no-build area from the lot. Calculations were performed in compliance with the requirements set forth in the Drainage Criteria Manual County of El Paso, Colorado (hereafter referred to as the "County Manual") and the Mile High Flood District Criteria Manuals (hereafter referred to as the "District Manual").

## Existing Drainage System

At the time of this report, grading for the building pad is complete. For the purposes of this report and in order to evaluate the impacts that the grading for the building pad has on the system, the "existing drainage" system will be evaluated as if the building pad had not been graded. The "proposed drainage" system will be evaluated with the building pad graded as-is.

The Final Drainage & Erosion Control Report for Woodmen Hills Subdivision Filing 9, Falcon, El Paso County, Colorado by URS Greiner Woodward Clyde dated October 19, 1999 (hereafter referred to as the "Master Drainage Report") provides the drainage information for the subject property. However, the drainage basin delineated on the drainage plans and the upstream neighborhood does not accurately depict the existing conditions.

Due to the discrepancies found in the Master Drainage Report described above, a new drainage basin was delineated using Lidar contours and aerial mapping. This basin E1 was found to be 14.23 acres in size. The same runoff coefficients were

used as in the Master Drainage Report, with the 5-yr coefficient being 0.41 and the 100-yr coefficient being 0.50. The 5-yr and 100-yr flow rates were found to be 8.4 cfs and 21.1 cfs, respectively.

RUNOFF SUMMARY							
BASIN LABEL	DESIGN POINT	AREA	Imp.	C5	C100	LOCAL (CFS)	
						Q5	Q100
E1	E1	14.23	0.45	0.41	0.50	8.4	21.1

Table 1 – Runoff Summary

To evaluate the existing drainage channel, a cross section was cut at station 0+75 where no grading has been performed. The existing channel is approximately 100ft wide and 4ft deep. Refer to Table 2 provided below for the flow, depth, velocity, and Froude number associated with station 0+75 that represents the existing conditions.

### Proposed Drainage System

The proposed improvements include a standalone RV garage located on the north side of the single-family dwelling. The proposed RV garage building pad extends into the existing drainage channel. The proposed drainage channel reduces the typical channel dimensions to approximately 30ft wide and 3.4ft deep. To evaluate the proposed improvements, a cross section at station 0+25 was created at the location of the grading that has already been performed. Table 2, presented below, compares the flow, depth, velocity, and Froude Number associated with station 0+25 (the proposed condition) and station 0+75 (the existing condition) for both the 5-yr and 100-yr storm events.

Storm Event	Station	Flow (cfs)	Depth (in)	Velocity (ft/s)	Froude Number
5-yr	0+25 (proposed)	8.4	12.0	1.09	0.238
5-yr	0+75 (existing)	8.4	7.7	0.70	0.216
100-yr	0+25 (proposed)	21.1	18.3	1.42	0.254
100-yr	0+75 (existing)	21.1	10.8	0.96	0.233

Table 2 – Results Summary

In the 5-yr storm event, the flow depth increases by approximately 4.3 inches and the velocity in the channel increases by 0.39 ft/s. In the 100-yr storm event, the depth in the channel increases by 7.5 inches and the velocity increases by 0.46 ft/s. In both scenarios, the Froude Number remains below 0.3. The threshold for most swale stabilization techniques is a Froude Number equal to or greater than 0.8. Therefore, the swale is anticipated to be at a low risk for erosion and scour.

It is recommended that the owner/contractor implement several measures to protect the proposed structure. This includes providing positive drainage away from the structure and adding an erosion blanket, riprap protection or other stabilization techniques along the slope of the building pad to mitigate erosion of the building pad.

## Conclusions

This letter summarizes the drainage improvements associated with the proposed RV garage. The proposed improvements increase the flow depth in the drainage swale by 4.3 inches and 7.5 inches for the 5-yr and 100-yr storm events, respectively. The erosion and scour potential in the drainage swale is considered low as the Froude Number remains less than 0.3 for both scenarios.

No floodplains are impacted by these improvements. No drainage requirements were found in the Master Drainage Report. The stormwater management system is designed to accommodate the 5-yr and 100-yr storm events in accordance with the District and County Manuals.

## References

1. **Master Drainage Report:** Final Drainage & Erosion Control Report for Woodmen Hills Subdivision Filing 9, Falcon, El Paso County, Colorado; URS Greiner Woodward Clyde; October 19, 1999.
2. **District Manual:** Mile High Flood District Criteria Manual Volumes 1, 2, & 3; Mile High Flood District, Denver, Colorado. Updated January 2016.
3. **County Manual:** Drainage Criteria Manual County of El Paso, Colorado. Revised October 31, 2018.
4. Web Soil Survey; Natural Resources Conservation Service. Accessed March 2024.

## **APPENDIX**



## **Appendix A**

*Vicinity Map*

*FEMA FIRM*

# VICINITY MAP

## 7981 FORT SMITH ROAD

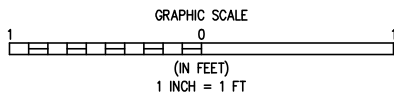
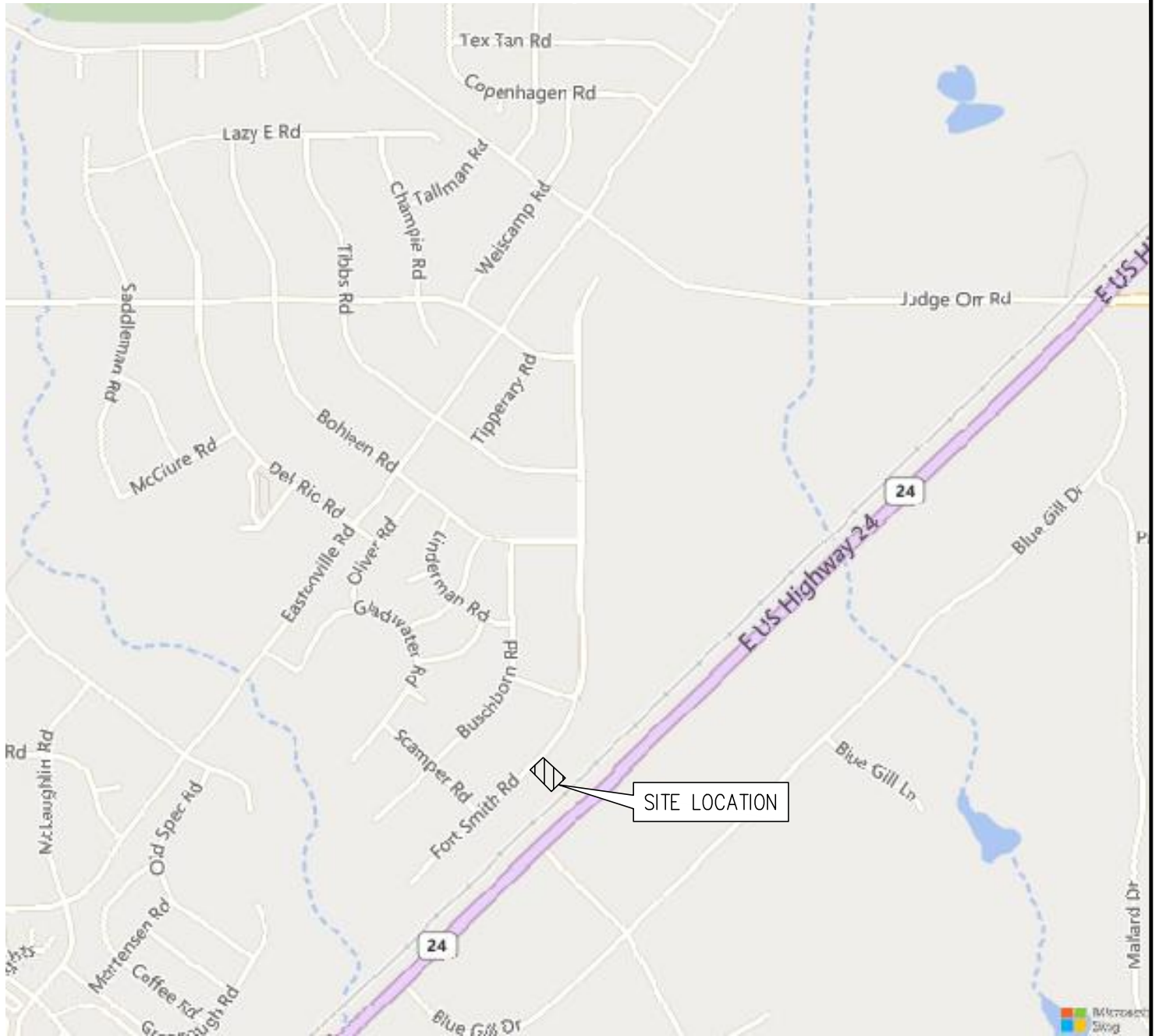

**BASELINE**

Engineering - Planning - Surveying

112 N RUBEY DRIVE, SUITE 210 - GOLDEN, COLORADO 80403  
P. 303.940.9966 - F. 303.940.9969 - www.baselinecorp.com

# National Flood Hazard Layer FIRMMette



104°35'48"W 38°57'2"N



## Legend

SEE FIS REPORT FOR DETAILED LEGEND AND INDEX MAP FOR FIRM PANEL LAYOUT

- |                             |  |  |
|-----------------------------|--|--|
| SPECIAL FLOOD HAZARD AREAS  |  | Without Base Flood Elevation (BFE)<br><i>Zone A, V, A99</i>  |
|                             |  | With BFE or Depth <i>Zone AE, AO, AH, VE, AR</i>   |
|                             |  | Regulatory Floodway  |
| OTHER AREAS OF FLOOD HAZARD |  | 0.2% Annual Chance Flood Hazard, Areas of 1% annual chance flood with average depth less than one foot or with drainage areas of less than one square mile <i>Zone X</i> |
|                             |  | Future Conditions 1% Annual Chance Flood Hazard <i>Zone X</i>  |
|                             |  | Area with Reduced Flood Risk due to Levee. See Notes. <i>Zone X</i>  |
|                             |  | Area with Flood Risk due to Levee <i>Zone D</i>  |
| OTHER AREAS                 |  | NO SCREEN Area of Minimal Flood Hazard <i>Zone X</i>   |
|                             |  | Effective LOMRs  |
| GENERAL STRUCTURES          |  | Area of Undetermined Flood Hazard <i>Zone D</i>  |
|                             |  | Channel, Culvert, or Storm Sewer   |
|                             |  | Levee, Dike, or Floodwall  |
| OTHER FEATURES              |  | 20.2 Cross Sections with 1% Annual Chance  |
|                             |  | 17.5 Water Surface Elevation   |
|                             |  | Coastal Transect   |
|                             |  | Base Flood Elevation Line (BFE)  |
|                             |  | Limit of Study   |
| MAP PANELS                  |  | Jurisdiction Boundary  |
|                             |  | Coastal Transect Baseline  |
|                             |  | Profile Baseline   |
|                             |  | Hydrographic Feature   |
|                             |  | Digital Data Available   |
|                             |  | No Digital Data Available  |
|                             |  | Unmapped   |
- The pin displayed on the map is an approximate point selected by the user and does not represent an authoritative property location.

This map complies with FEMA's standards for the use of digital flood maps if it is not void as described below. The basemap shown complies with FEMA's basemap accuracy standards

The flood hazard information is derived directly from the authoritative NFHL web services provided by FEMA. This map was exported on **4/10/2024 at 6:13 PM** and does not reflect changes or amendments subsequent to this date and time. The NFHL and effective information may change or become superseded by new data over time.

This map image is void if the one or more of the following map elements do not appear: basemap imagery, flood zone labels, legend, scale bar, map creation date, community identifiers, FIRM panel number, and FIRM effective date. Map images for unmapped and unmodernized areas cannot be used for regulatory purposes.

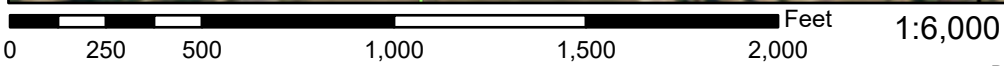

## **Appendix B**

*NOAA Atlas Rainfall Data*

*Hydrologic Rational Calculations*

*Hydraulic Calculations*



**POINT PRECIPITATION FREQUENCY ESTIMATES**

Sanja Perica, Deborah Martin, Sandra Pavlovic, Ishani Roy, Michael St. Laurent, Carl Trypaluk, Dale Unruh, Michael Yekta, Geoffery Bonnin

NOAA, National Weather Service, Silver Spring, Maryland

[PF\\_tabular](#) | [PF\\_graphical](#) | [Maps & aerials](#)

**PF tabular**

<b>PDS-based point precipitation frequency estimates with 90% confidence intervals (in inches)<sup>1</sup></b>										
Duration	Average recurrence interval (years)									
	1	2	5	10	25	50	100	200	500	1000
5-min	0.238 (0.192-0.298)	0.290 (0.233-0.364)	0.380 (0.304-0.478)	0.459 (0.366-0.580)	0.576 (0.445-0.758)	0.671 (0.505-0.893)	0.770 (0.560-1.05)	0.876 (0.611-1.23)	1.02 (0.686-1.47)	1.14 (0.743-1.66)
10-min	0.349 (0.280-0.437)	0.425 (0.341-0.533)	0.557 (0.446-0.700)	0.673 (0.536-0.849)	0.843 (0.652-1.11)	0.982 (0.740-1.31)	1.13 (0.821-1.54)	1.28 (0.895-1.80)	1.50 (1.00-2.15)	1.67 (1.09-2.43)
15-min	0.425 (0.342-0.533)	0.518 (0.416-0.649)	0.679 (0.543-0.853)	0.820 (0.653-1.04)	1.03 (0.795-1.35)	1.20 (0.902-1.60)	1.38 (1.00-1.88)	1.56 (1.09-2.19)	1.83 (1.22-2.63)	2.04 (1.33-2.96)
30-min	0.611 (0.491-0.765)	0.744 (0.598-0.933)	0.973 (0.779-1.22)	1.18 (0.936-1.48)	1.47 (1.14-1.94)	1.71 (1.29-2.28)	1.96 (1.43-2.68)	2.23 (1.56-3.12)	2.61 (1.74-3.74)	2.90 (1.89-4.21)
60-min	0.785 (0.631-0.983)	0.941 (0.756-1.18)	1.22 (0.976-1.53)	1.47 (1.17-1.86)	1.86 (1.44-2.46)	2.18 (1.65-2.92)	2.52 (1.84-3.46)	2.90 (2.02-4.07)	3.43 (2.30-4.94)	3.86 (2.51-5.60)
2-hr	0.959 (0.777-1.19)	1.14 (0.921-1.42)	1.47 (1.18-1.83)	1.77 (1.42-2.22)	2.24 (1.76-2.96)	2.65 (2.02-3.52)	3.08 (2.27-4.20)	3.56 (2.52-4.98)	4.25 (2.88-6.10)	4.82 (3.16-6.94)
3-hr	1.05 (0.857-1.30)	1.23 (1.00-1.53)	1.58 (1.28-1.96)	1.91 (1.54-2.38)	2.43 (1.92-3.21)	2.89 (2.22-3.84)	3.39 (2.51-4.61)	3.95 (2.80-5.51)	4.76 (3.24-6.81)	5.42 (3.58-7.79)
6-hr	1.22 (1.00-1.50)	1.41 (1.16-1.73)	1.79 (1.46-2.21)	2.17 (1.76-2.68)	2.77 (2.22-3.65)	3.31 (2.57-4.39)	3.91 (2.93-5.30)	4.58 (3.29-6.37)	5.57 (3.83-7.93)	6.38 (4.24-9.11)
12-hr	1.40 (1.16-1.70)	1.63 (1.35-1.98)	2.07 (1.70-2.53)	2.50 (2.05-3.06)	3.18 (2.56-4.15)	3.78 (2.96-4.96)	4.45 (3.36-5.98)	5.19 (3.75-7.16)	6.28 (4.36-8.87)	7.17 (4.81-10.2)
24-hr	1.61 (1.34-1.94)	1.89 (1.58-2.28)	2.41 (2.00-2.91)	2.89 (2.39-3.52)	3.65 (2.95-4.68)	4.30 (3.38-5.57)	5.00 (3.80-6.64)	5.78 (4.20-7.88)	6.90 (4.82-9.66)	7.82 (5.29-11.0)
2-day	1.87 (1.57-2.23)	2.20 (1.85-2.63)	2.80 (2.34-3.36)	3.34 (2.78-4.03)	4.17 (3.38-5.28)	4.86 (3.84-6.22)	5.60 (4.27-7.35)	6.40 (4.68-8.64)	7.54 (5.30-10.5)	8.46 (5.77-11.8)
3-day	2.05 (1.73-2.44)	2.41 (2.04-2.87)	3.06 (2.57-3.65)	3.64 (3.04-4.37)	4.51 (3.68-5.68)	5.24 (4.16-6.67)	6.02 (4.62-7.86)	6.86 (5.04-9.20)	8.04 (5.68-11.1)	8.99 (6.17-12.5)
4-day	2.20 (1.87-2.61)	2.58 (2.19-3.07)	3.26 (2.75-3.88)	3.86 (3.24-4.62)	4.77 (3.90-5.98)	5.53 (4.40-7.01)	6.33 (4.87-8.24)	7.20 (5.31-9.63)	8.42 (5.98-11.6)	9.41 (6.48-13.1)
7-day	2.61 (2.22-3.07)	3.01 (2.57-3.55)	3.73 (3.17-4.41)	4.38 (3.69-5.20)	5.34 (4.40-6.64)	6.14 (4.93-7.74)	7.00 (5.43-9.05)	7.93 (5.89-10.5)	9.23 (6.60-12.6)	10.3 (7.13-14.2)
10-day	2.96 (2.54-3.47)	3.40 (2.91-3.99)	4.18 (3.56-4.91)	4.87 (4.13-5.75)	5.89 (4.87-7.28)	6.74 (5.43-8.44)	7.64 (5.94-9.82)	8.60 (6.42-11.4)	9.96 (7.14-13.6)	11.0 (7.69-15.2)
20-day	3.96 (3.42-4.60)	4.56 (3.93-5.30)	5.57 (4.79-6.50)	6.44 (5.51-7.55)	7.68 (6.37-9.35)	8.67 (7.02-10.7)	9.68 (7.58-12.3)	10.7 (8.06-14.0)	12.2 (8.80-16.4)	13.3 (9.35-18.2)
30-day	4.76 (4.13-5.50)	5.50 (4.77-6.36)	6.71 (5.80-7.79)	7.72 (6.64-9.01)	9.12 (7.58-11.0)	10.2 (8.29-12.5)	11.3 (8.87-14.2)	12.4 (9.35-16.1)	13.9 (10.1-18.6)	15.0 (10.6-20.5)
45-day	5.76 (5.03-6.62)	6.65 (5.80-7.66)	8.08 (7.02-9.33)	9.24 (7.98-10.7)	10.8 (9.00-12.9)	12.0 (9.77-14.6)	13.2 (10.4-16.4)	14.3 (10.8-18.4)	15.8 (11.5-21.0)	16.9 (12.0-22.9)
60-day	6.60 (5.78-7.57)	7.60 (6.64-8.72)	9.18 (8.00-10.6)	10.4 (9.06-12.1)	12.1 (10.1-14.4)	13.4 (10.9-16.2)	14.6 (11.5-18.1)	15.7 (11.9-20.2)	17.2 (12.6-22.8)	18.3 (13.0-24.7)

<sup>1</sup> Precipitation frequency (PF) estimates in this table are based on frequency analysis of partial duration series (PDS).

Numbers in parenthesis are PF estimates at lower and upper bounds of the 90% confidence interval. The probability that precipitation frequency estimates (for a given duration and average recurrence interval) will be greater than the upper bound (or less than the lower bound) is 5%. Estimates at upper bounds are not checked against probable maximum precipitation (PMP) estimates and may be higher than currently valid PMP values.

Please refer to NOAA Atlas 14 document for more information.

[Back to Top](#)

**PF graphical**

PDS-based depth-duration-frequency (DDF) curves  
 Latitude: 38.9466°, Longitude: -104.5915°

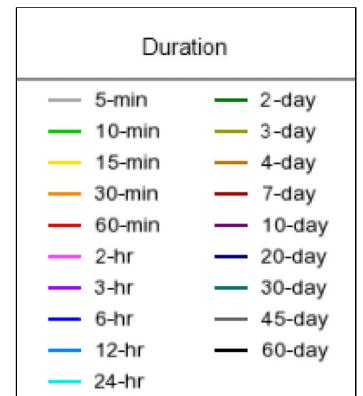
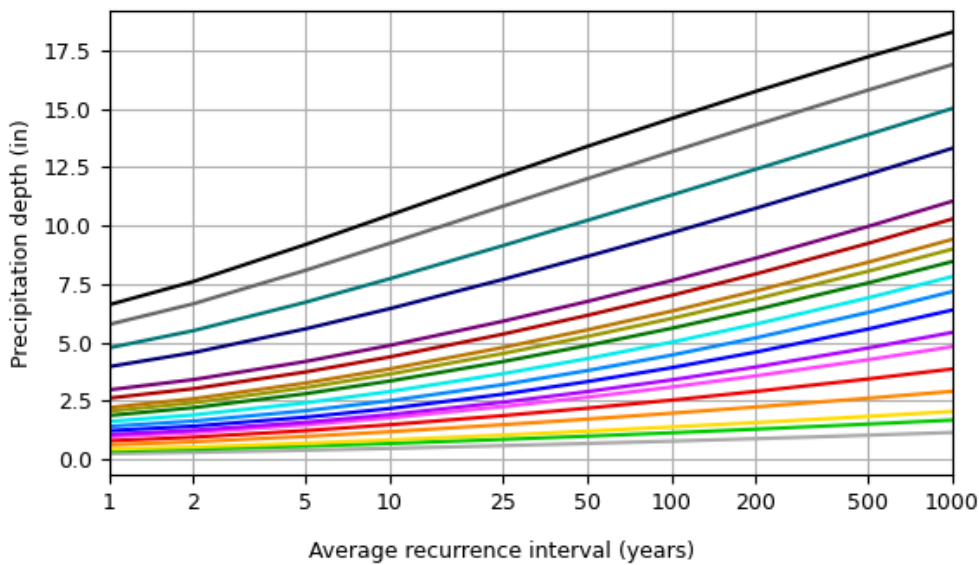
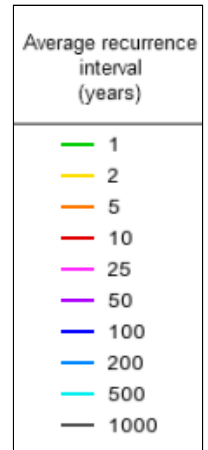
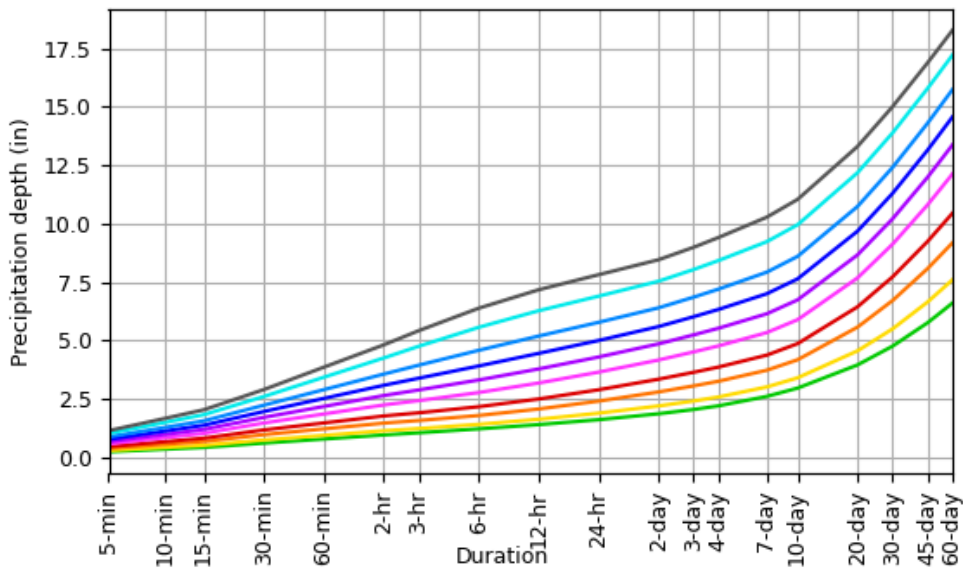

[Back to Top](#)

**Maps & aerials**

Small scale terrain



Large scale terrain



Large scale map



Large scale aerial

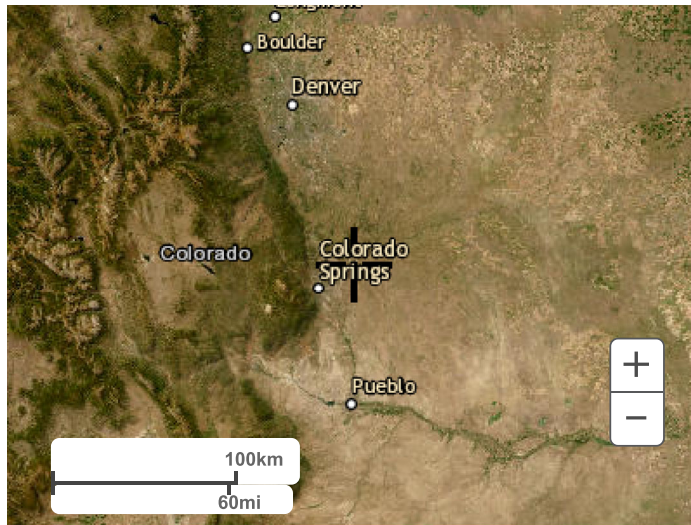

[Back to Top](#)

---

[US Department of Commerce](#)  
[National Oceanic and Atmospheric Administration](#)  
[National Weather Service](#)  
[National Water Center](#)  
1325 East West Highway  
Silver Spring, MD 20910  
Questions?: [HDSC.Questions@noaa.gov](mailto:HDSC.Questions@noaa.gov)

[Disclaimer](#)





Engineering · Planning · Surveying

PROJECT: Ft Smith Rd  
 JOB NO.: 35079  
 CALC. BY: M Sundstrom  
 DATE: 4/9/2024

= FORMULA CELLS  
 = USER INPUT CELLS

Project Location	
User Input	▼

**IDF Rainfall Data**

T <sub>d</sub> Minutes	P <sub>1</sub> : 1-hour Rainfall Depths (inches)	
	Minor Storm	Major Storm
	5-Year	100-Year
	▼	▼
	<b>1.22</b>	<b>2.52</b>
5	4.14	8.55
10	3.30	6.82
20	2.40	4.96
30	1.91	3.95
40	1.61	3.32
50	1.39	2.87
60	1.23	2.55
120	0.76	1.57

Equation 5-1  $I = (28.5 * P_1) / (10 + T_d)^{0.786}$   
 I = rainfall intensity (inches per hour)  
 P<sub>1</sub> = 1-hour point rainfall depth (inches)  
 T<sub>d</sub> = storm duration (minutes)

- Reference:
- 1) Urban Drainage and Flood Control District - Urban Storm Drainage Criteria Manual Volume 1, 2017
  - 2) NOAA Atlas 14, Volume 8, Version 2  
[http://hdsc.nws.noaa.gov/hdsc/pfds/pfds\\_map\\_cont.html?bkmrk=co](http://hdsc.nws.noaa.gov/hdsc/pfds/pfds_map_cont.html?bkmrk=co)

PROJECT: Ft Smith Rd  
 JOB NO.: 35079  
 CALC. BY: M Sundstrom  
 DATE: 4/9/2024



**Impervious Percentages - from Urban Drainage Table 6-3**

User Defined	45%	Land Use	0
Residential - 0.25 AC or less	45%	Land Use	0
Land Use	0	Land Use	0
Land Use	0	Land Use	0

SOIL TYPE:  (use equation from Table 6-4)

= FORMULA CELLS  
 = USER INPUT CELLS

**PROPOSED COMPOSITE IMPERVIOUSNESS**

Basin	Area (ac)	Weighted Impervious and C Values					Areas (ac)								
		Imp.	C <sub>2</sub>	C <sub>5</sub>	C <sub>10</sub>	C <sub>100</sub>	User Defined	Residential - 0.25 AC or less	Land Use	Land Use	Land Use	Land Use	Land Use	Land Use	
E1	14.23	45%	-	0.41	-	0.50	14.23								

Runoff Coefficients  
 obtained from Master  
 Drainage Report

**STANDARD FORM SF-2**  
**TIME OF CONCENTRATION SUMMARY**

Calculated By: M Sundstrom  
 Date: 4/9/2024

Project: Ft Smith Rd  
 Job No.: 35079  
 Checked By: xxxxxxxxxx

SUB-BASIN DATA				INITIAL/OVERLAND TIME (t <sub>i</sub> )			TRAVEL TIME (t <sub>t</sub> )					t <sub>c</sub> CHECK (URBANIZED BASINS)				FINAL t <sub>c</sub>	REMARKS
Basin	i	C <sub>s</sub>	AREA	LENGTH	SLOPE	t <sub>i</sub>	LENGTH	Cv	SLOPE	VEL.	t <sub>t</sub>	COMP.	TOT. LENGTH	S <sub>o</sub>	tc (Equation 6-5)		
(1)	(2)	(3)	Ac	Ft	%	Min	Ft		%	FPS	Min	t <sub>c</sub>	Ft	%	Min	Min	
(4)	(5)	(6)	(7)	(8)	(9)	(10)	(11)	(12)	(13)	(14)	(15)	(16)					
E1	0.45	0.41	14.23	300	2.0	17.17	3,500	7	2.0	0.99	58.93	76.1	3,800	2.00	47.6	47.62	

Equation 6-3  $t_t = ((0.395(1.1 - C_s) \sqrt{L}) / (S_o^{0.33}))$

Equation 6-5  $t_c = (26 - 17i) + (L / (60(14i + 9) \sqrt{S_o}))$

= FORMULA CELLS  
 = USER INPUT CELLS

Heavy Meadow	2.5
Tillage/Field	5
Short Pasture and Lawns	7
Nearly Bare Ground	10
Grassed Waterway	15
Paved Areas and Shallow Paved Swales	20

Calculated By: M Sundstrom

Date: 4/9/2024

Checked By: xxxxxxxxxx

5-Year

1-hour rainfall= **1.22**

### STANDARD FORM SF-3

STORM DRAINAGE SYSTEM DESIGN  
(RATIONAL METHOD PROCEDURE)

Project: Ft Smith Rd

Job No.: 35079

Design Storm: 5-Year

= FORMULA CELLS

= USER INPUT CELLS

BASIN	DIRECT RUNOFF								TOTAL RUNOFF				STREET		PIPE			LENGTH (FT)	VELOCITY (FPS)	t (MIN)	REMARKS
	DESIGN POINT	AREA DESIGN	AREA (AC)	RUNOFF COEFF	t <sub>c</sub> (MIN)	C*A (AC)	I (IN/HR)	Q (CFS)	t <sub>c</sub> (MIN)	S (C*A) (CA)	I (IN/HR)	Q (CFS)	SLOPE (%)	STREET FLOW	DESIGN FLOW (CFS)	SLOPE (%)	PIPE DIAM. (IN.)				
	(2)	(3)	(4)	(5)	(6)	(7)	(8)	(9)	(10)	(11)	(12)	(13)	(14)	(15)	(16)	(17)	(18)	(19)	(20)	(21)	(22)
E1	E1		14.23	0.41	47.6	5.83	1.44	<b>8.4</b>													

Calculated By: M Sundstrom

Date: 4/9/2024

Checked By: xxxxxxxxxx

100-Year

1-hour rainfall= **2.52**

### STANDARD FORM SF-3

STORM DRAINAGE SYSTEM DESIGN  
(RATIONAL METHOD PROCEDURE)

Project: Ft Smith Rd

Job No.: 35079

Design Storm: 100-Year

= FORMULA CELLS

= USER INPUT CELLS

BASIN	DIRECT RUNOFF								TOTAL RUNOFF				STREET		PIPE			LENGTH (FT)	VELOCITY (FPS)	t (MIN)	REMARKS
	DESIGN POINT	AREA DESIGN	AREA (AC)	RUNOFF COEFF	t <sub>c</sub> (MIN)	C*A (AC)	I (IN/HR)	Q (CFS)	t <sub>c</sub> (MIN)	S (C*A) (CA)	I (IN/HR)	Q (CFS)	SLOPE (%)	STREET FLOW	DESIGN FLOW (CFS)	SLOPE (%)	PIPE DIAM. (IN.)				
	(2)	(3)	(4)	(5)	(6)	(7)	(8)	(9)	(10)	(11)	(12)	(13)	(14)	(15)	(16)	(17)	(18)	(19)	(20)	(21)	(22)
E1	E1		14.23	0.50	47.6	7.12	2.97	<b>21.1</b>													

PROJECT: Ft Smith Rd  
 JOB NO.: 35079  
 CALC. BY: M Sundstrom  
 DATE: 4/9/2024



RUNOFF SUMMARY								Notes
BASIN LABEL	DESIGN POINT	AREA	Imp.	C5	C100	LOCAL (CFS)		
						Q5	Q100	
E1	E1	14.23	0.45	0.41	0.50	8.4	21.1	

= FORMULA CELLS  
 = USER INPUT CELLS

## Worksheet for Section 0+25 - 5yr

Project Description	
Friction Method	Manning Formula
Solve For	Normal Depth
Input Data	
Channel Slope	0.002 ft/ft
Discharge	8.40 cfs

### Section Definitions

Station (ft)	Elevation (ft)
0+00	6,881.80
0+19	6,877.92
0+25	6,878.25
0+30	6,881.33

### Roughness Segment Definitions

Start Station	Ending Station	Roughness Coefficient
(0+00, 6,881.80)	(0+30, 6,881.33)	0.045

#### Options

Current Roughness Weighted Method	Pavlovskii's Method
Open Channel Weighting Method	Pavlovskii's Method
Closed Channel Weighting Method	Pavlovskii's Method

#### Results

Normal Depth	12.0 in
Roughness Coefficient	0.045
Elevation	6,878.92 ft
Elevation Range	6,877.9 to 6,881.8 ft
Flow Area	7.7 ft <sup>2</sup>
Wetted Perimeter	12.2 ft
Hydraulic Radius	7.6 in
Top Width	11.89 ft
Normal Depth	12.0 in
Critical Depth	6.1 in
Critical Slope	0.044 ft/ft
Velocity	1.09 ft/s
Velocity Head	0.02 ft
Specific Energy	1.01 ft
Froude Number	0.238
Flow Type	Subcritical

## Worksheet for Section 0+25 - 5yr

---

### GVF Input Data

---

Downstream Depth	0.0 in
Length	0.0 ft
Number Of Steps	0

---

### GVF Output Data

---

Upstream Depth	0.0 in
Profile Description	N/A
Profile Headloss	0.00 ft
Downstream Velocity	0.00 ft/s
Upstream Velocity	0.00 ft/s
Normal Depth	12.0 in
Critical Depth	6.1 in
Channel Slope	0.002 ft/ft
Critical Slope	0.044 ft/ft

---



## Cross Section for Section 0+25 - 5yr

Project Description	
Friction Method	Manning Formula
Solve For	Normal Depth

Input Data	
Channel Slope	0.002 ft/ft
Normal Depth	12.0 in
Discharge	8.40 cfs

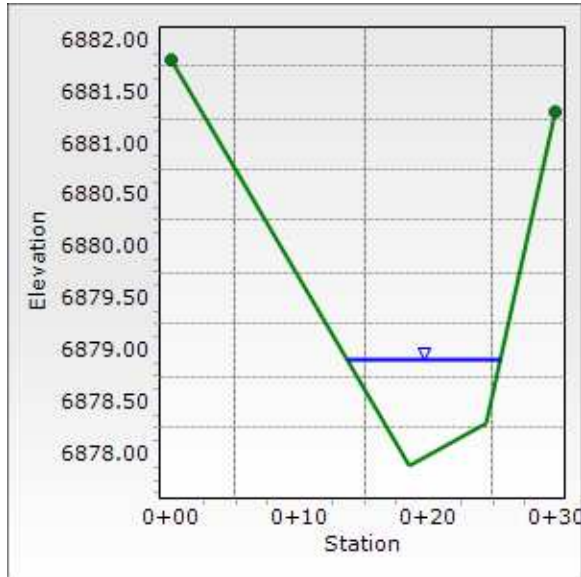

## Worksheet for Section 0+75 - 5yr

Project Description	
Friction Method	Manning Formula
Solve For	Normal Depth
Input Data	
Channel Slope	0.002 ft/ft
Discharge	8.40 cfs

### Section Definitions

Station (ft)	Elevation (ft)
0+00	6,881.73
0+21	6,878.37
0+46	6,877.75
0+83	6,879.87
1+02	6,881.84

### Roughness Segment Definitions

Start Station	Ending Station	Roughness Coefficient
(0+00, 6,881.73)	(1+02, 6,881.84)	0.045

#### Options

Current Roughness Weighted Method	Pavlovskii's Method
Open Channel Weighting Method	Pavlovskii's Method
Closed Channel Weighting Method	Pavlovskii's Method

#### Results

Normal Depth	7.7 in
Roughness Coefficient	0.045
Elevation	6,878.39 ft
Elevation Range	6,877.8 to 6,881.8 ft
Flow Area	11.9 ft <sup>2</sup>
Wetted Perimeter	36.3 ft
Hydraulic Radius	3.9 in
Top Width	36.26 ft
Normal Depth	7.7 in
Critical Depth	4.2 in
Critical Slope	0.053 ft/ft
Velocity	0.70 ft/s
Velocity Head	0.01 ft
Specific Energy	0.65 ft
Froude Number	0.216
Flow Type	Subcritical

## Worksheet for Section 0+75 - 5yr

---

### GVF Input Data

---

Downstream Depth	0.0 in
Length	0.0 ft
Number Of Steps	0

---

### GVF Output Data

---

Upstream Depth	0.0 in
Profile Description	N/A
Profile Headloss	0.00 ft
Downstream Velocity	0.00 ft/s
Upstream Velocity	0.00 ft/s
Normal Depth	7.7 in
Critical Depth	4.2 in
Channel Slope	0.002 ft/ft
Critical Slope	0.053 ft/ft

---

## Cross Section for Section 0+75 - 5yr

Project Description	
Friction Method	Manning Formula
Solve For	Normal Depth

Input Data	
Channel Slope	0.002 ft/ft
Normal Depth	7.7 in
Discharge	8.40 cfs

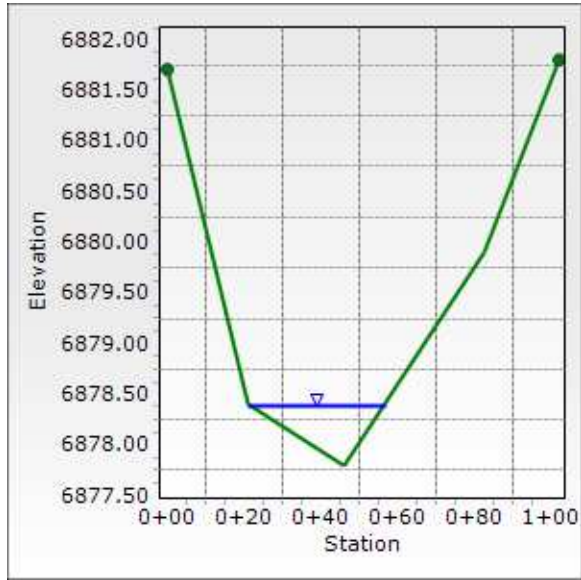

## Worksheet for Section 0+25 - 100yr

Project Description	
Friction Method	Manning Formula
Solve For	Normal Depth
Input Data	
Channel Slope	0.002 ft/ft
Discharge	21.10 cfs

### Section Definitions

Station (ft)	Elevation (ft)
0+00	6,881.80
0+19	6,877.92
0+25	6,878.25
0+30	6,881.33

### Roughness Segment Definitions

Start Station	Ending Station	Roughness Coefficient
(0+00, 6,881.80)	(0+30, 6,881.33)	0.045

#### Options

Current Roughness Weighted Method	Pavlovskii's Method
Open Channel Weighting Method	Pavlovskii's Method
Closed Channel Weighting Method	Pavlovskii's Method

#### Results

Normal Depth	18.3 in
Roughness Coefficient	0.045
Elevation	6,879.44 ft
Elevation Range	6,877.9 to 6,881.8 ft
Flow Area	14.9 ft <sup>2</sup>
Wetted Perimeter	15.8 ft
Hydraulic Radius	11.3 in
Top Width	15.33 ft
Normal Depth	18.3 in
Critical Depth	9.3 in
Critical Slope	0.038 ft/ft
Velocity	1.42 ft/s
Velocity Head	0.03 ft
Specific Energy	1.55 ft
Froude Number	0.254
Flow Type	Subcritical

## Worksheet for Section 0+25 - 100yr

---

### GVF Input Data

---

Downstream Depth	0.0 in
Length	0.0 ft
Number Of Steps	0

---

### GVF Output Data

---

Upstream Depth	0.0 in
Profile Description	N/A
Profile Headloss	0.00 ft
Downstream Velocity	0.00 ft/s
Upstream Velocity	0.00 ft/s
Normal Depth	18.3 in
Critical Depth	9.3 in
Channel Slope	0.002 ft/ft
Critical Slope	0.038 ft/ft

---

## Cross Section for Section 0+25 - 100yr

Project Description	
Friction Method	Manning Formula
Solve For	Normal Depth

Input Data	
Channel Slope	0.002 ft/ft
Normal Depth	18.3 in
Discharge	21.10 cfs

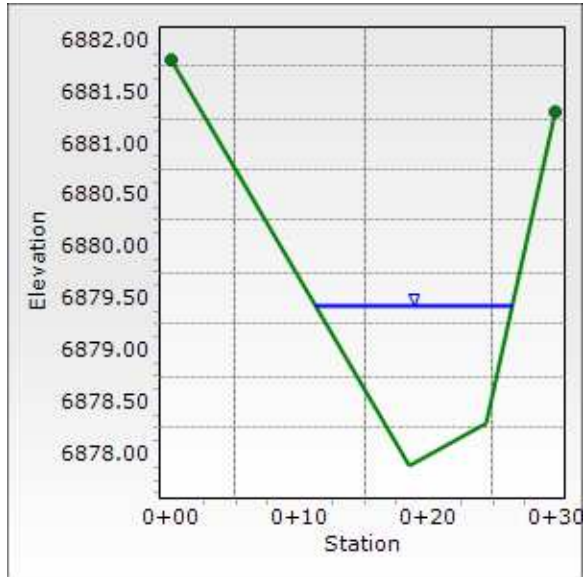

## Worksheet for Section 0+75 - 100yr

Project Description	
Friction Method	Manning Formula
Solve For	Normal Depth
Input Data	
Channel Slope	0.002 ft/ft
Discharge	21.10 cfs

### Section Definitions

Station (ft)	Elevation (ft)
0+00	6,881.73
0+21	6,878.37
0+46	6,877.75
0+83	6,879.87
1+02	6,881.84

### Roughness Segment Definitions

Start Station	Ending Station	Roughness Coefficient
(0+00, 6,881.73)	(1+02, 6,881.84)	0.045

#### Options

Current Roughness Weighted Method	Pavlovskii's Method
Open Channel Weighting Method	Pavlovskii's Method
Closed Channel Weighting Method	Pavlovskii's Method

#### Results

Normal Depth	10.8 in
Roughness Coefficient	0.045
Elevation	6,878.65 ft
Elevation Range	6,877.8 to 6,881.8 ft
Flow Area	22.1 ft <sup>2</sup>
Wetted Perimeter	42.4 ft
Hydraulic Radius	6.2 in
Top Width	42.37 ft
Normal Depth	10.8 in
Critical Depth	6.1 in
Critical Slope	0.047 ft/ft
Velocity	0.96 ft/s
Velocity Head	0.01 ft
Specific Energy	0.92 ft
Froude Number	0.233
Flow Type	Subcritical



## Worksheet for Section 0+75 - 100yr

---

### GVF Input Data

---

Downstream Depth	0.0 in
Length	0.0 ft
Number Of Steps	0

---

### GVF Output Data

---

Upstream Depth	0.0 in
Profile Description	N/A
Profile Headloss	0.00 ft
Downstream Velocity	0.00 ft/s
Upstream Velocity	0.00 ft/s
Normal Depth	10.8 in
Critical Depth	6.1 in
Channel Slope	0.002 ft/ft
Critical Slope	0.047 ft/ft

---

## Cross Section for Section 0+75 - 100yr

Project Description	
Friction Method	Manning Formula
Solve For	Normal Depth

Input Data	
Channel Slope	0.002 ft/ft
Normal Depth	10.8 in
Discharge	21.10 cfs

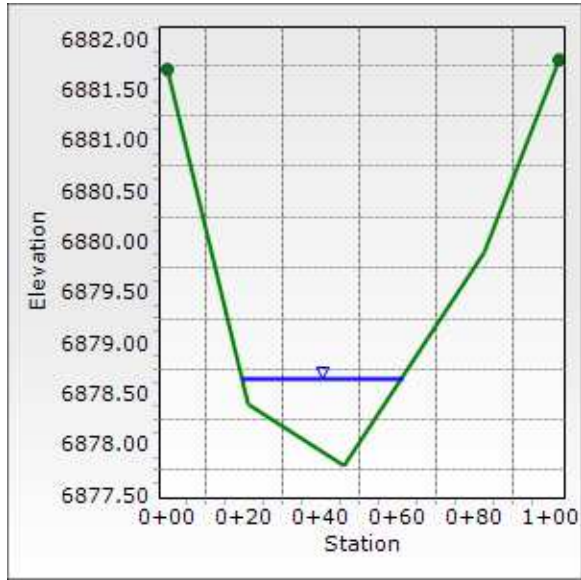

## **Appendix C**

*Excerpts from Master Drainage Report*

**FINAL DRAINAGE &  
EROSION CONTROL REPORT FOR  
WOODMEN HILLS SUBDIVISION FILING 9,  
FALCON, EL PASO COUNTY, COLORADO**

October 19, 1999

Prepared for:

**FALCON PROPERTIES AND INVESTMENTS, LLP  
11720 Woodmen Hills Drive  
Falcon, CO 80831**

Prepared by:

**URS GREINER WOODWARD CLYDE  
8415 EXPLORER DR, SUITE 110  
COLORADO SPRINGS, CO 80920**

**URSGWC Project No. 67-00042363**

CERTIFICATIONS

Engineer's Statement:

The attached drainage plan and report were prepared under my direction and supervision and are correct to the best of my knowledge and belief. Said drainage report has been prepared according to the criteria established by the City/County for drainage reports and said report is in conformity with the master plan of the drainage basin. I accept responsibility for any liability caused by any negligent acts, errors or omissions on my part in preparing this report.

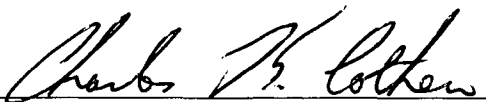

Charles K. Cothern, PE # 24997

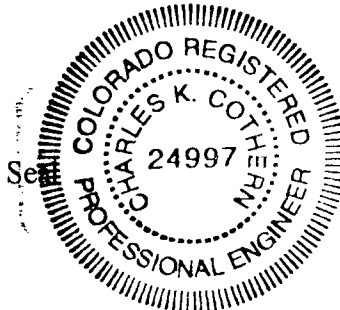

Developer's Statement:

I, the developer have read and will comply with all of the requirements specified in this drainage report and plan.

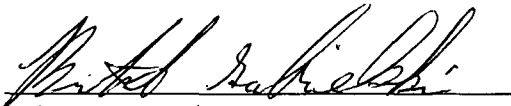

Falcon Properties & Investments, LLC.

By: Butch Gabrielski

Title: Land Development Mgr.

Address: 11720 Woodmen Hills Dr.  
Falcon, CO 80831

El Paso County's Statement

Filed in accordance with Section 51.1 of the El Paso Land Development Code, as amended.

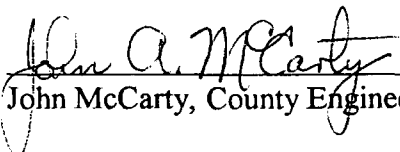
  
John McCarty, County Engineer/Director

12-14-99  
Date

Conditions:

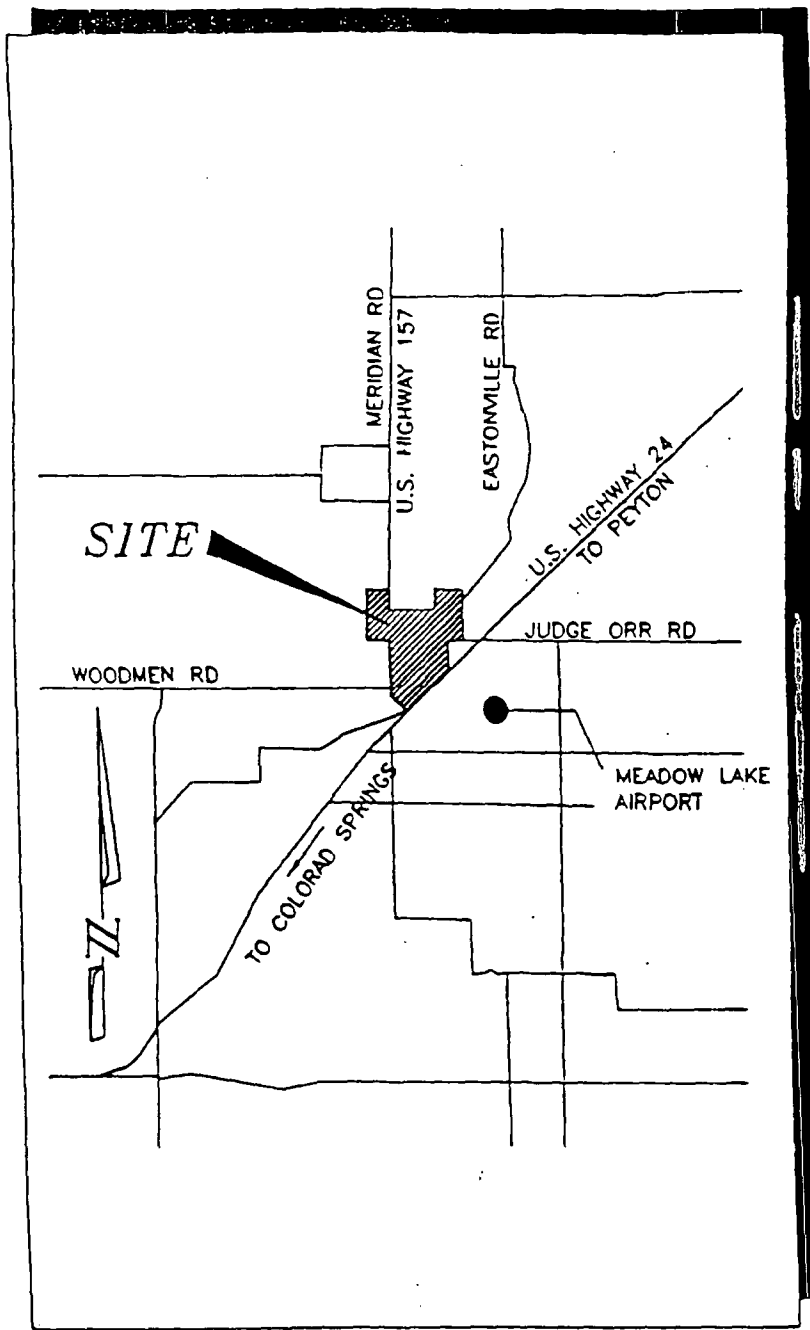

VICINITY MAP  
N.T.S.

Fig 1 - dmap of 12/2/98

**URS Greiner Woodward Clyde**  
8415 Explorer Dr, Suite 110  
Colorado Springs, CO 80915  
719.531.0001 fax: 719.531.0007

**VICINITY MAP**

**FIGURE**  
**1**

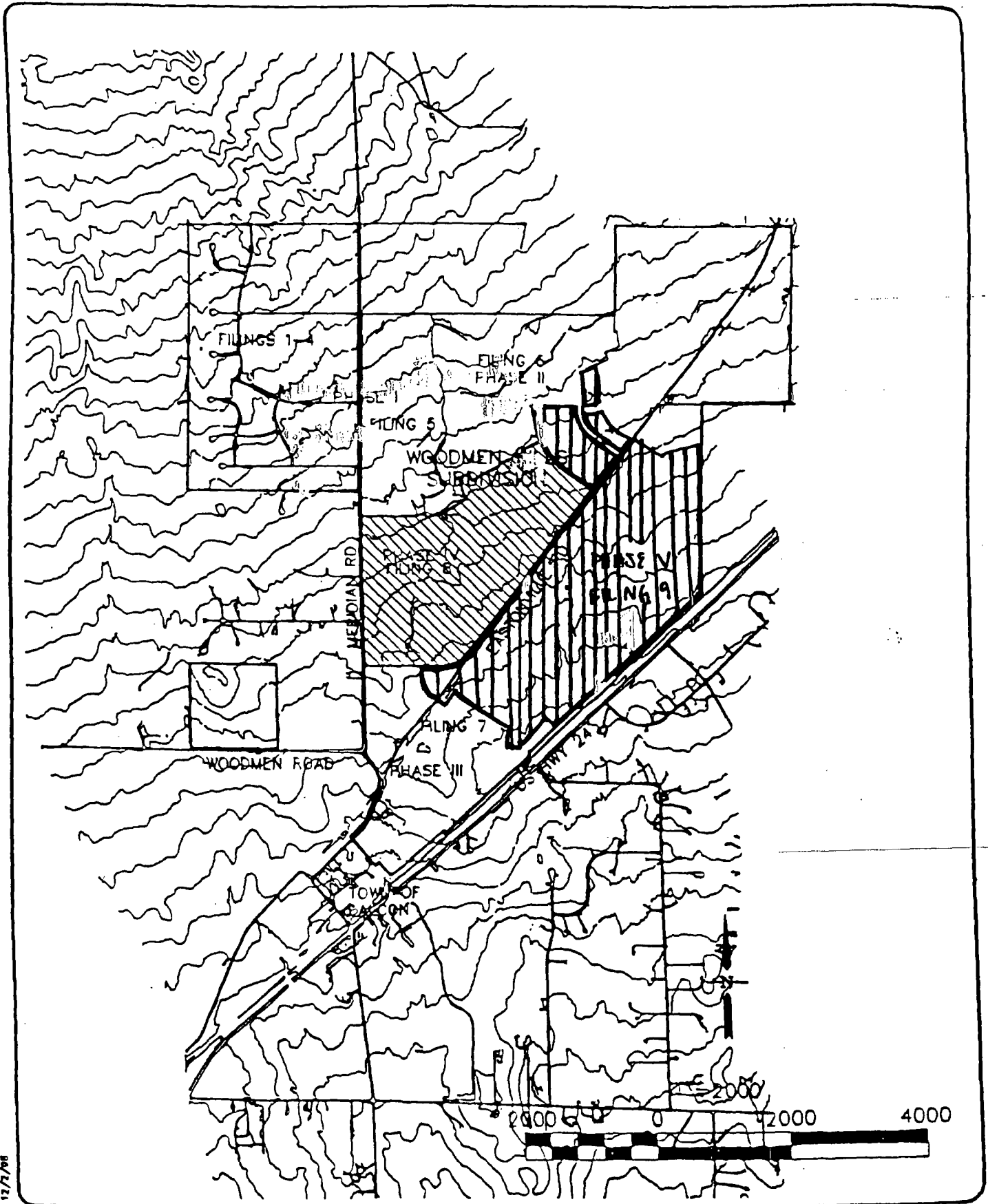

Fig 2 - SUBDIVISION.dwg 12/7/98

**U'S Breiner Woodward Clyde**  
 6415 Explorer Dr, Suite 110  
 Colorado Springs, CO 80915  
 719.531.0001 fax 719.531.0007  
 PROJ NO. 6742238.08

# WOODMEN HILLS SUBDIVISION

**FIGURE  
 2**

JCHHS PAT

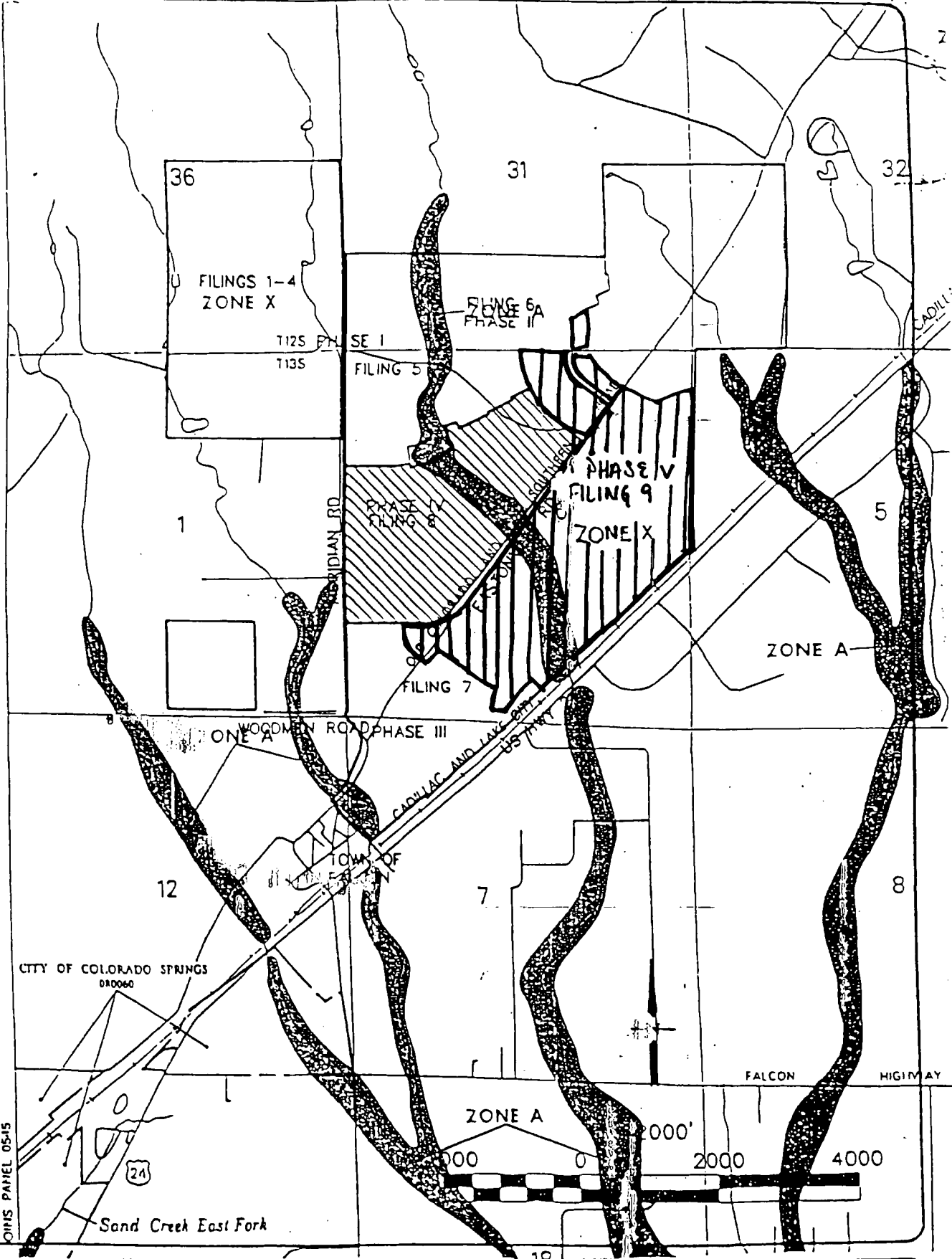

11/7/98

843-REUAmop.dwg dr

**URS Greiner Woodward Clyde**  
 8415 Explorer Dr, Suite 110  
 Colorado Springs, CO 80915  
 719.531.0001 fax: 719.531.0007  
 PROJ NO. 8742238.08

**WOODMEN HILLS SUBDIVISION  
 FEMA FLOOD INSURANCE RATE MAP**

**FIGURE  
 3**



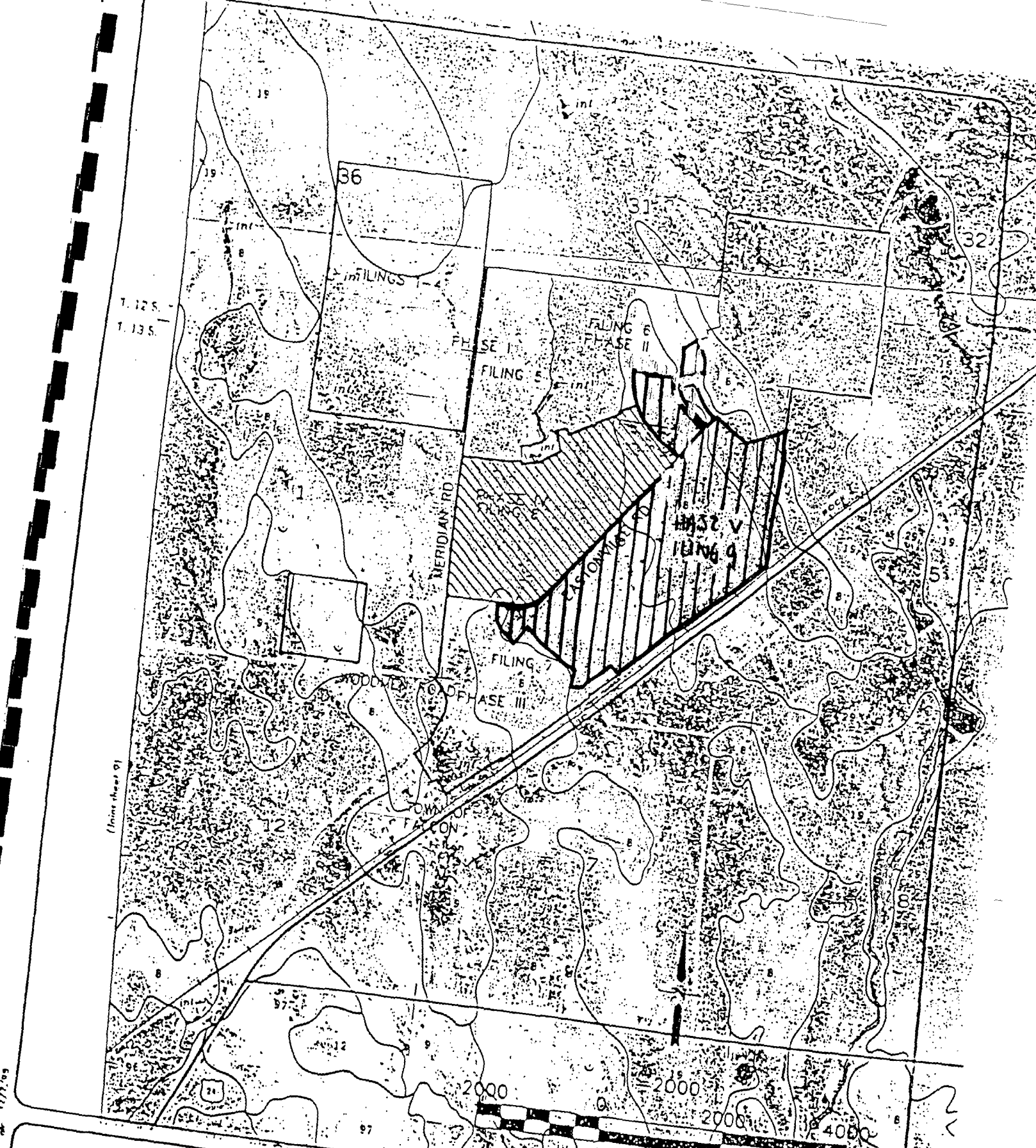

URS Bralner Woodward Clyde  
 8415 Explorer Dr. Suite 110  
 Colorado Springs, CO 80915  
 719.531.0001 fax: 719.531.0007

# WOODMEN HILLS SUBDIVISION SOILS MAP

FIGURE  
 4

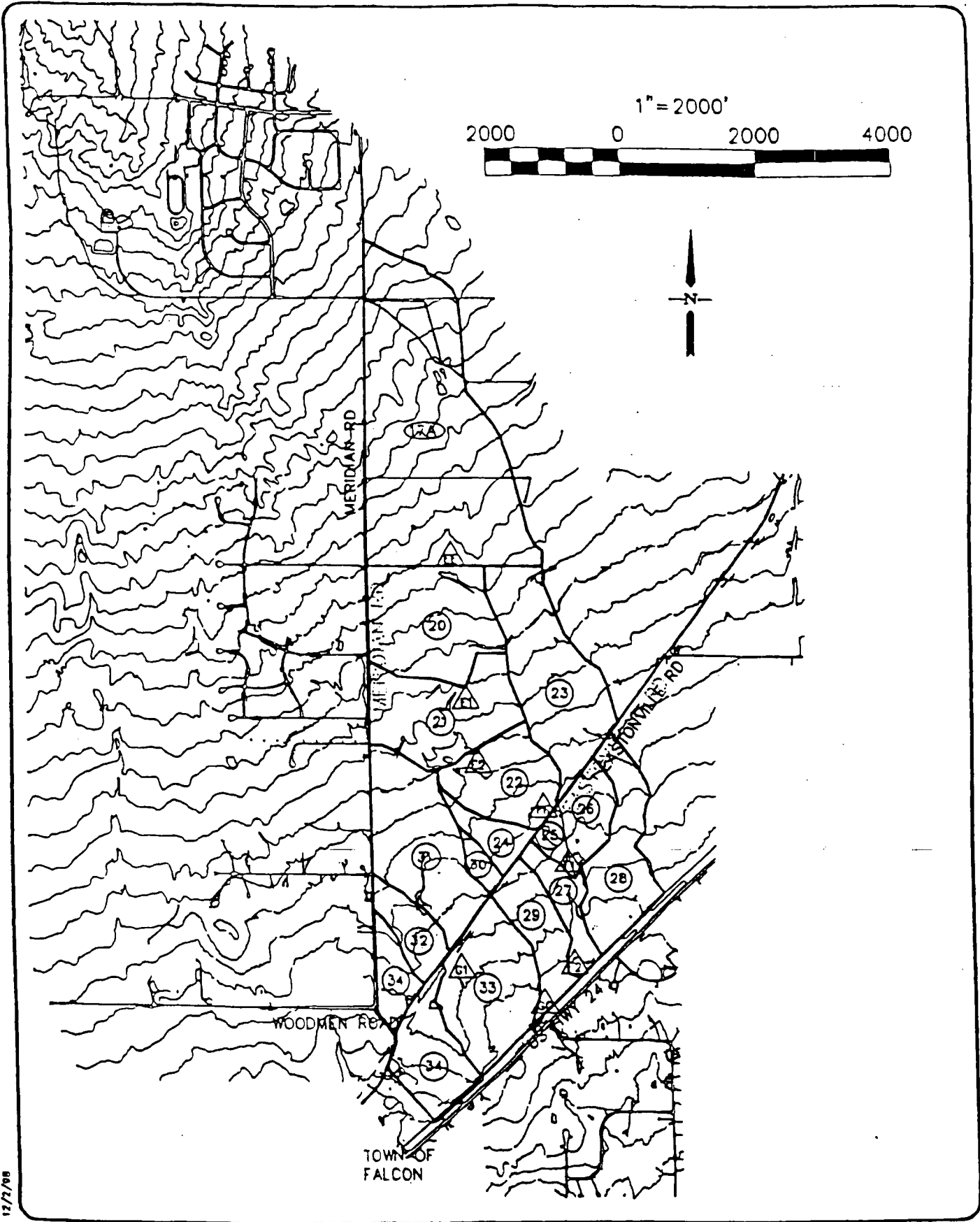

945-INSTASPLS.dwg dr 12/7/98

**URS Brener Woodward Clyde**

8415 Explorer Dr, Suite 110  
 Colorado Springs, CO 80915  
 719.531.0001 fax 719.531.0007

# WOODMEN HILLS SUBDIVISION HISTORIC BASINS

**FIGURE**

**5**

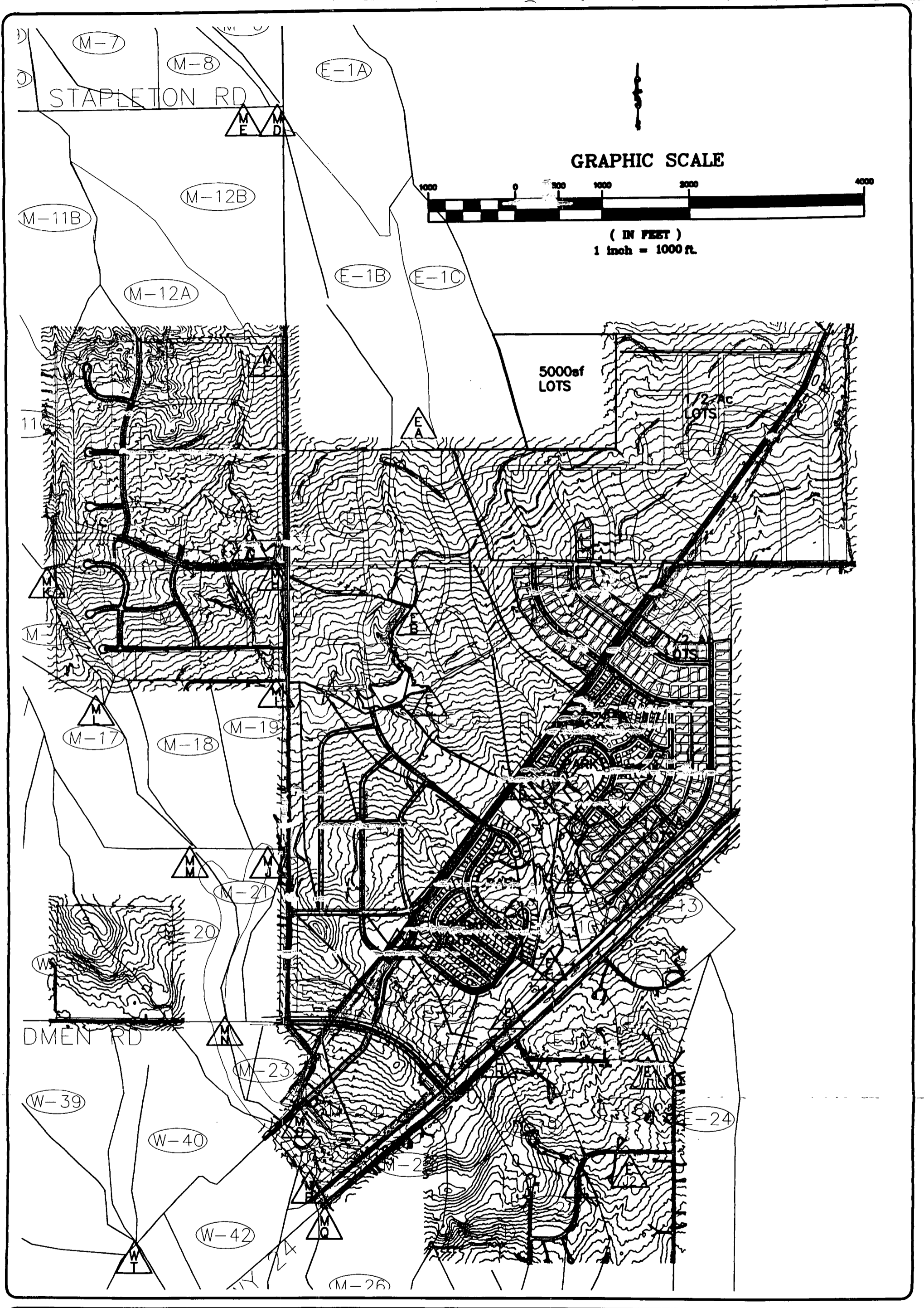

**URS Greiner Woodward Clyde**

8415 Explorer Dr, Suite 110  
 Colorado Springs, CO 80915  
 719.531.0001 fax: 719.531.0007

PROJ NO. 6742363.09

**WOODMEN HILLS SUBDIVISION  
 DEVELOPED CONDITION BASINS**

FIGURE

6

Woodman Hills Flng #0 Part 2

Preliminary Drainage Calculations

Average Channel Velocity

5 ft/s

Average Slope

0.02 ft/ft

(If Elevations are used, this will be ignored)

Basin	Total Area sf	Total Area acres	Surface Type 1		Surface Type 2		Surface Type 3		Surface Type 4		Average Slope	Average Length ft	Average Initial Length ft	Channel Flow Length ft	True Channel Length ft	High Point Elevation	Low Point Elevation	Average Slope	Initial To	Channel Total To	IS InVr	OS cfs	100 InVr	Q100 cfs			
			CS	C100	CS	C100	CS	C100	CS	C100																	
26.1	110104	2.53	0.00	0.05	11920	0.35	0.45	98184			0.41	0.50	540.00	300.00	0.00	240.00	8932.00	8921.00	0.020	17.84	0.00	17.84	3.25	3.38	5.80	7.14	
26.2	113127	2.60	0.00	0.05	4416	0.35	0.45	108711			0.37	0.47	305.00	300.00	210.00	215.00	8929.00	8921.00	0.018	20.37	0.70	21.07	2.90	2.79	5.04	6.15	
26.3	827718	1.44	0.00	0.05	4416	0.35	0.45	58303			0.39	0.49	190.00	190.00	210.00	210.00	8925.00	8921.00	0.010	18.33	0.70	19.03	3.05	1.71	5.30	3.76	
26.4	858803	15.12	0.00	0.05	85328	0.35	0.45	593475			0.40	0.50	270.00	270.00	3910.00	3810.00	8920.00	8984.00	0.014	19.23	12.70	31.93	2.35	14.38	4.08	30.87	
26.5	125540	2.88	0.00	0.05	22590	0.35	0.45	102990			0.45	0.54	155.00	155.00	970.00	970.00	8920.00	8910.00	0.018	12.51	3.23	15.75	3.45	4.48	5.90	9.18	
26.6	148158	3.22	0.00	0.05	8994	0.35	0.45	131260			0.38	0.48	815.00	300.00	165.00	380.00	8928.00	8918.00	0.018	19.17	0.55	19.72	3.05	3.78	5.30	8.22	
26.7	92339	2.12	0.00	0.05	8994	0.35	0.45	93443			0.40	0.50	240.00	240.00	335.00	335.00	8922.00	8918.00	0.010	19.91	1.12	21.02	2.89	2.47	5.04	5.32	
26.8	52131	1.20	0.00	0.05	8672	0.35	0.45	43459			0.44	0.53	273.00	275.00	55.00	55.00	8924.00	8918.00	0.024	15.20	0.18	15.38	3.45	1.72	5.00	3.78	
26.9	142381	3.27	0.00	0.05	12208	0.35	0.45	130193			0.40	0.49	445.00	300.00	150.00	295.00	8919.00	8909.00	0.017	19.15	0.50	19.65	3.05	3.96	5.30	8.54	
26.10	180219	4.14	0.00	0.05	21424	0.35	0.45	158794			0.42	0.51	195.00	195.00	985.00	985.00	8922.00	8909.00	0.011	17.31	3.28	20.59	2.95	5.07	5.15	10.85	
26.11	45088	0.96	0.00	0.05	8738	0.35	0.45	36352			0.44	0.53	330.00	300.00	0.00	30.00	8907.00	8900.00	0.021	16.74	0.00	16.74	3.35	1.44	5.75	3.00	
26.12	349547	8.02	0.00	0.05	24180	0.38	0.48	323387			0.39	0.49	835.00	300.00	795.00	1130.00	8922.00	8900.00	0.015	19.89	2.95	22.84	2.83	8.88	4.93	18.28	
26.13	125085	2.87	0.00	0.05	24180	0.40	0.70	38338	0.35	0.45	80587			100.00	100.00	1280.00	1280.00	8922.00	8900.00	0.018	8.94	4.27	13.20	3.71	5.77	8.38	11.53
26.14	440433	10.11	0.00	0.05	29528	0.35	0.45	413805			0.38	0.48	525.00	300.00	1185.00	1380.00	8901.00	8981.00	0.012	21.95	3.88	25.83	2.85	10.27	4.80	22.32	
26.15	354977	8.15	0.00	0.05	23200	0.35	0.45	331777			0.38	0.48	440.00	300.00	860.00	1000.00	8984.00	8985.00	0.015	20.38	2.87	23.25	2.77	8.71	4.82	18.88	
26.16	90341	1.36	0.00	0.05	5800	0.35	0.70	43377			0.63	0.72	280.00	280.00	125.00	125.00	8917.00	8905.00	0.031	9.74	0.42	10.15	4.10	3.51	5.00	5.02	
26.17	45897	1.05	0.00	0.05	4254	0.40	0.70	27777			0.63	0.72	205.00	205.00	185.00	185.00	8906.00	8905.00	0.011	12.32	0.53	12.87	3.84	2.54	6.59	2.78	
26.18	24581	0.56	0.00	0.05	4254	0.40	0.70	27777			0.65	0.74	105.00	105.00	180.00	180.00	8906.00	8905.00	0.004	11.88	0.53	12.41	3.84	1.41	6.59	2.78	
26.19	11808	0.27	0.00	0.05	3120	0.40	0.70	27777			0.68	0.77	85.00	85.00	115.00	115.00	8903.00	8900.00	0.015	8.34	0.38	8.72	5.02	4.92	8.81	1.79	
26.20	80792	1.40	0.00	0.05	6880	0.40	0.70	45080			0.64	0.74	210.00	210.00	280.00	280.00	8912.00	8900.00	0.024	9.17	0.93	10.10	4.10	3.88	7.05	7.25	
26.21	50180	1.15	0.00	0.05	5120	0.40	0.70	34070			0.63	0.73	200.00	200.00	185.00	195.00	8902.00	8900.00	0.005	15.57	0.95	16.22	3.35	2.43	5.75	4.81	
26.22	29190	0.67	0.00	0.05	5120	0.40	0.70	34070			0.65	0.74	100.00	100.00	240.00	240.00	8902.00	8900.00	0.008	9.88	0.80	10.78	4.10	1.79	7.05	3.51	
26.23	27420	0.83	0.00	0.05	6224	0.40	0.70	27481			0.67	0.76	130.00	130.00	250.00	250.00	8910.00	8900.00	0.028	6.87	0.83	7.50	4.79	2.01	8.22	3.82	
26.24	33716	0.77	0.00	0.05	6224	0.40	0.70	27481			0.66	0.75	125.00	125.00	270.00	270.00	8906.00	8900.00	0.015	6.08	0.80	6.89	4.58	2.31	7.83	4.52	
26.25	48581	1.12	0.00	0.05	7970	0.40	0.70	48611			0.65	0.74	145.00	145.00	245.00	245.00	8906.00	8907.00	0.003	15.98	0.92	16.79	3.35	2.43	5.75	4.75	
26.26	29488	0.68	0.00	0.05	7970	0.40	0.70	48611	0.35	0.45	17458			105.00	105.00	250.00	250.00	8904.00	8907.00	0.020	8.71	0.83	9.55	4.33	1.55	7.44	3.10
26.27	73870	1.82	0.00	0.05	8798	0.40	0.70	7988	0.35	0.45	88107			205.00	205.00	285.00	285.00	8906.00	8907.00	0.018	15.42	0.95	16.37	3.35	2.58	5.75	5.45
26.28	184407	4.26	0.00	0.05	20000	0.35	0.45	184407			0.41	0.50	205.00	205.00	1105.00	1105.00	8902.00	8986.00	0.012	17.31	3.88	20.98	2.95	5.18	5.15	11.10	
26.29	217840	5.00	0.00	0.05	14980	0.40	0.70	31380	0.35	0.45	171500			340.00	300.00	805.00	845.00	8924.00	8982.00	0.044	13.32	2.02	15.34	3.45	3.71	5.90	15.34
26.30	42538	0.98	0.00	0.05	8200	0.40	0.70	29118	0.35	0.45	8225			225.00	225.00	185.00	185.00	8988.00	8982.00	0.015	12.84	0.82	13.26	3.71	2.13	8.59	4.74
26.31	58888	1.31	0.00	0.05	9200	0.40	0.70	4800	0.35	0.45	48088			110.00	110.00	230.00	230.00	8987.00	8982.00	0.015	11.84	0.47	12.41	3.84	2.13	8.59	4.48
26.32	140708	3.23	0.00	0.05	8352	0.40	0.70	18807	0.35	0.45	116488			375.00	300.00	140.00	215.00	8987.00	8976.00	0.021	17.29	0.47	17.75	3.25	4.33	5.80	8.22
26.33	170128	3.91	0.00	0.05	18808	0.35	0.45	18411			0.40	0.50	270.00	270.00	815.00	815.00	8984.00	8978.00	0.007	22.77	2.72	26.49	2.80	4.07	4.51	8.74	
		0.00									0.00	0.00			0.00				0.020	0.00	0.00	5.00	5.25	8.00	9.00	8.00	
		0.00									0.00	0.00			0.00				0.020	0.00	0.00	5.00	5.25	8.00	9.00	8.00	
		0.00									0.00	0.00			0.00				0.020	0.00	0.00	5.00	5.25	8.00	9.00	8.00	
		0.00									0.00	0.00			0.00				0.020	0.00	0.00	5.00	5.25	8.00	9.00	8.00	
		0.00									0.00	0.00			0.00				0.020	0.00	0.00	5.00	5.25	8.00	9.00	8.00	
		0.00									0.00	0.00			0.00				0.020	0.00	0.00	5.00	5.25	8.00	9.00	8.00	
		0.00									0.00	0.00			0.00				0.020	0.00	0.00	5.00	5.25	8.00	9.00	8.00	

# FINAL DRAINAGE PLAN SHEET 1 OF 2

## WOODMEN HILLS SUBDIVISION FILING No. 9

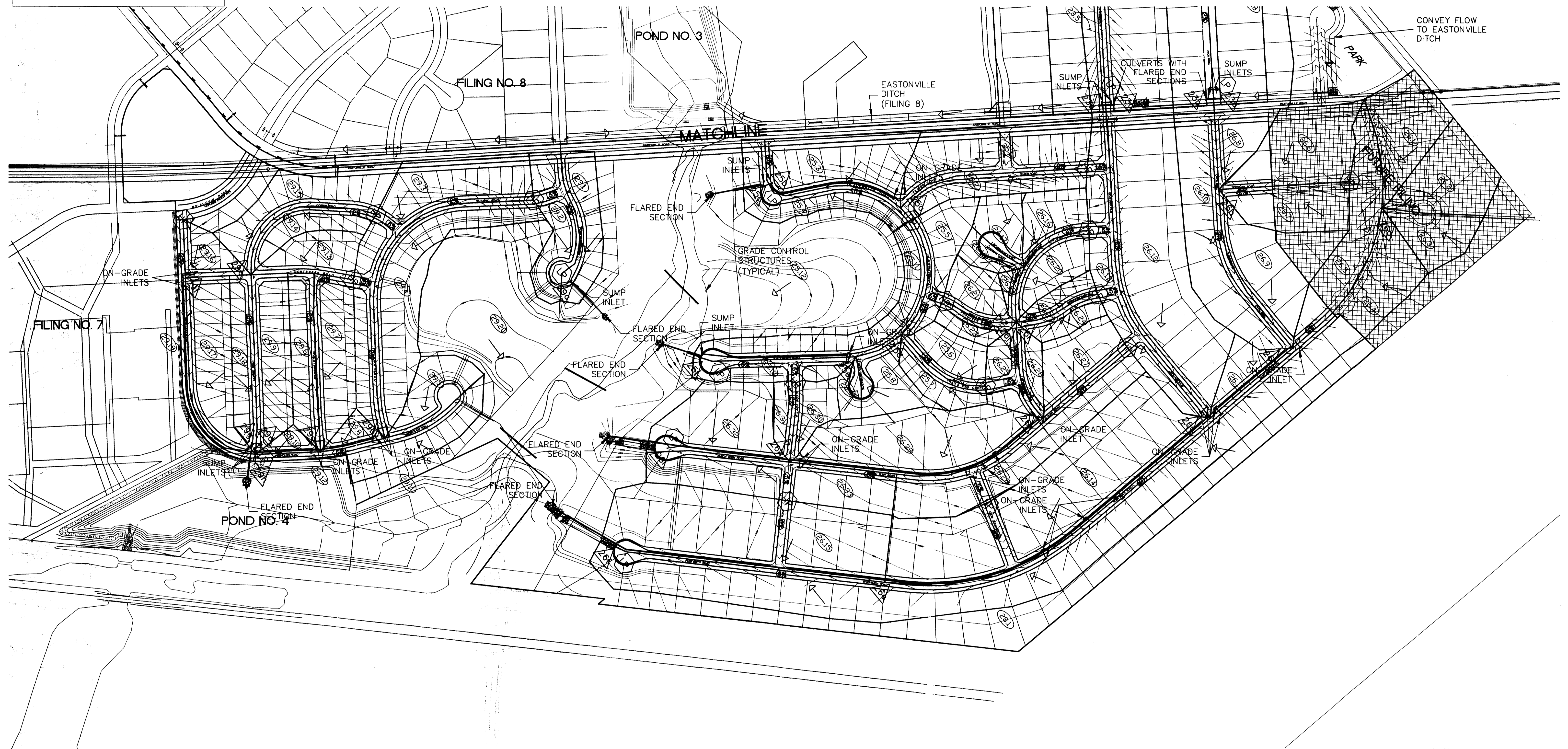
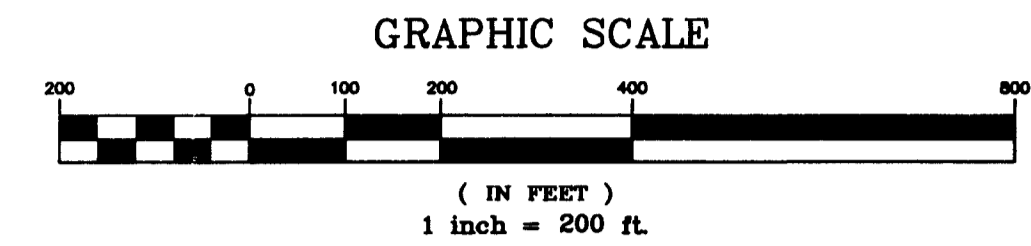
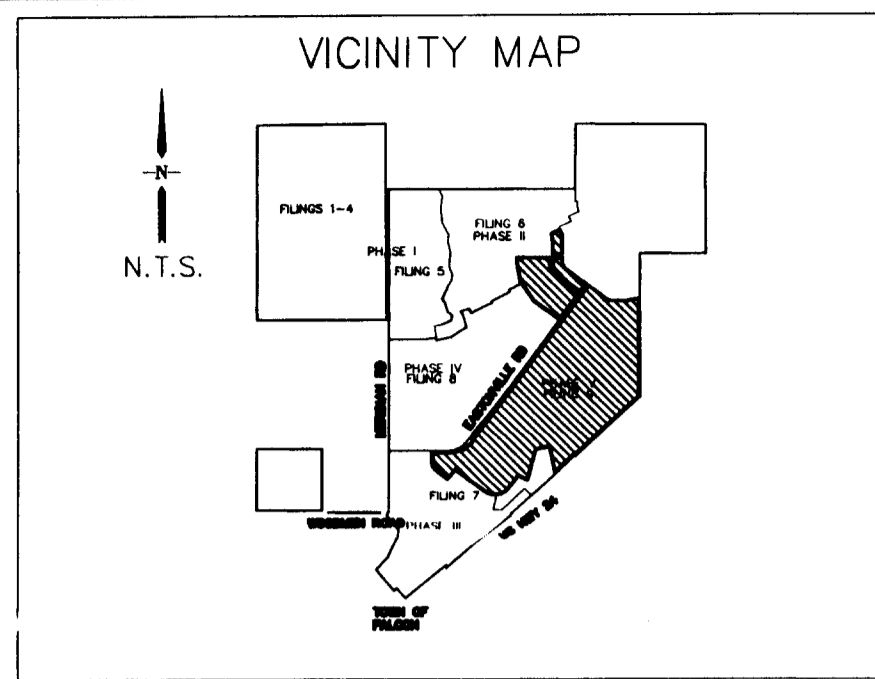

### LEGEND

(25.12)

SUB-BASIN



FLOW DIRECTION

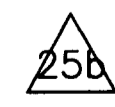

DESIGN POINTS



HIGH POINT / LOW POINT



ESTIMATED STREET SLOPE

**WOODMEN HILLS**  
ROOM TO GROW

**URS Greiner Woodward Clyde**

8415 EXPLORER DRIVE, STE 110  
COLORADO SPRINGS, CO 80920  
(719) 531-0001

SHEET 1 OF 2

\\ur-ws16716742363\CD\Filing 9\drainage\FINAL.dwg Thu Oct 26 16:42:18 1999 Plotted by EDE

# FINAL DRAINAGE PLAN SHEET 2 OF 2 WOODMEN HILLS SUBDIVISION FILING No. 9

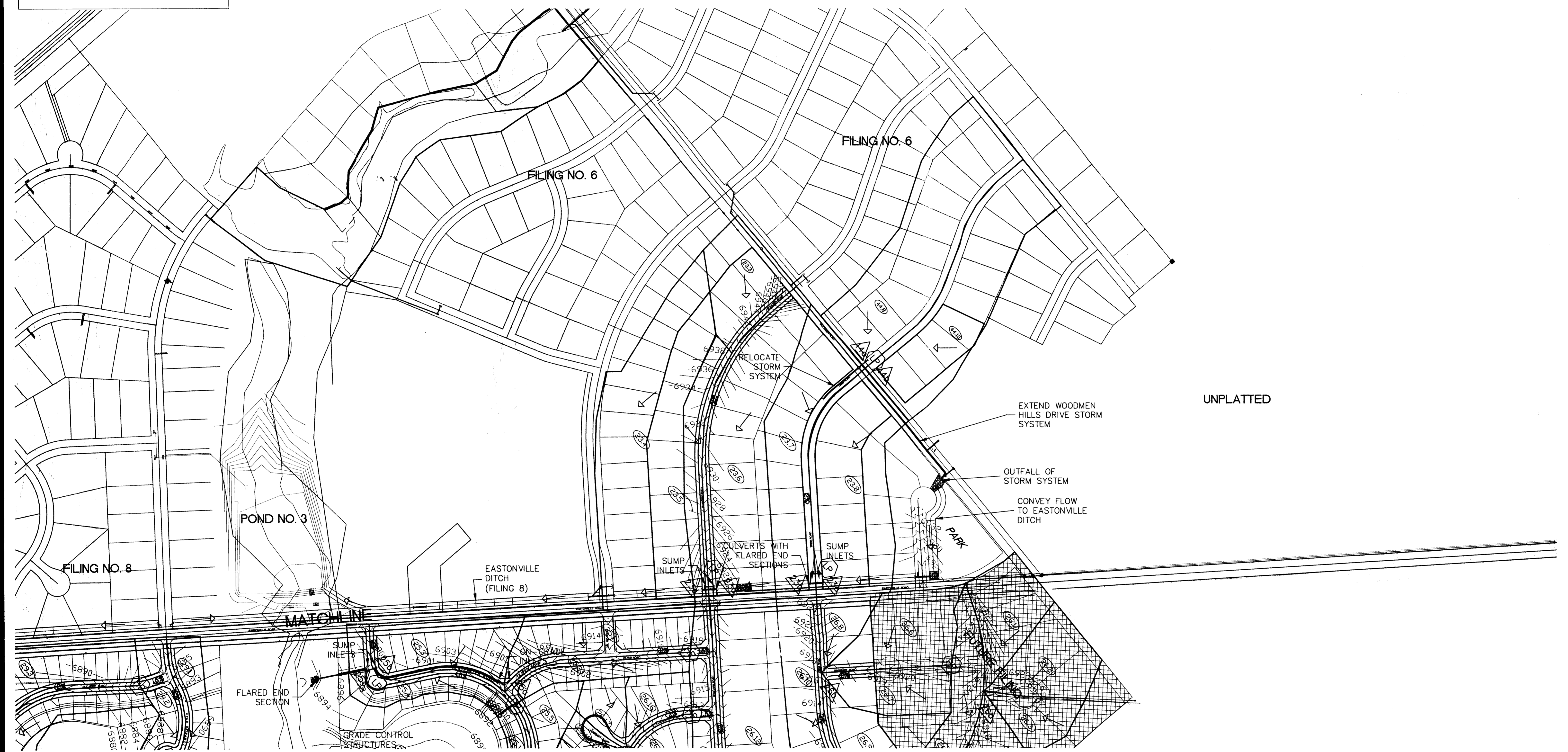
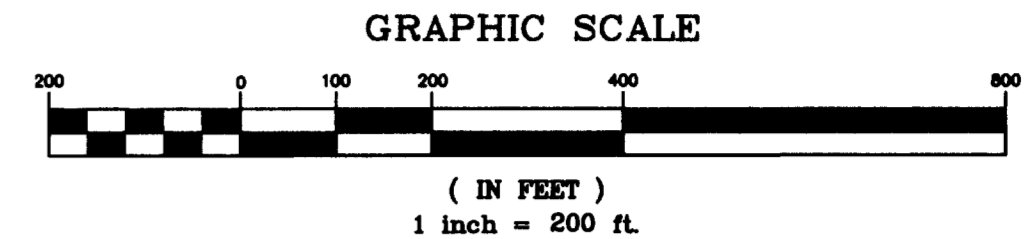
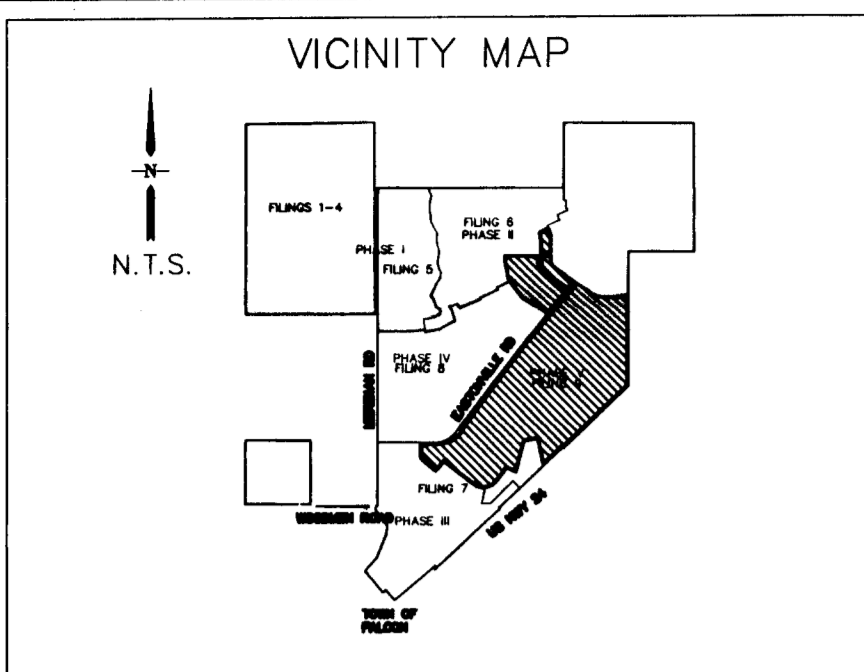

### LEGEND

- |                |                        |                        |
|----------------|------------------------|------------------------|
| SUB-BASIN      | DESIGN POINTS          | ESTIMATED STREET SLOPE |
| FLOW DIRECTION | HIGH POINT / LOW POINT |                        |

**WOODMEN HILLS**  
ROOM TO GROW

**URS Greiner Woodward Clyde**  
8415 EXPLORER DRIVE, STE 110  
COLORADO SPRINGS, CO 80920  
(719) 531-0001  
SHEET 2 OF 2

## **Appendix D**

### *Drainage Plans*





R:\35079CS FT Smith Rd Drainage Letter\Drawings\Drainage Maps.dwg, 4/11/2024 9:09:29 AM, Mark Sundstrom

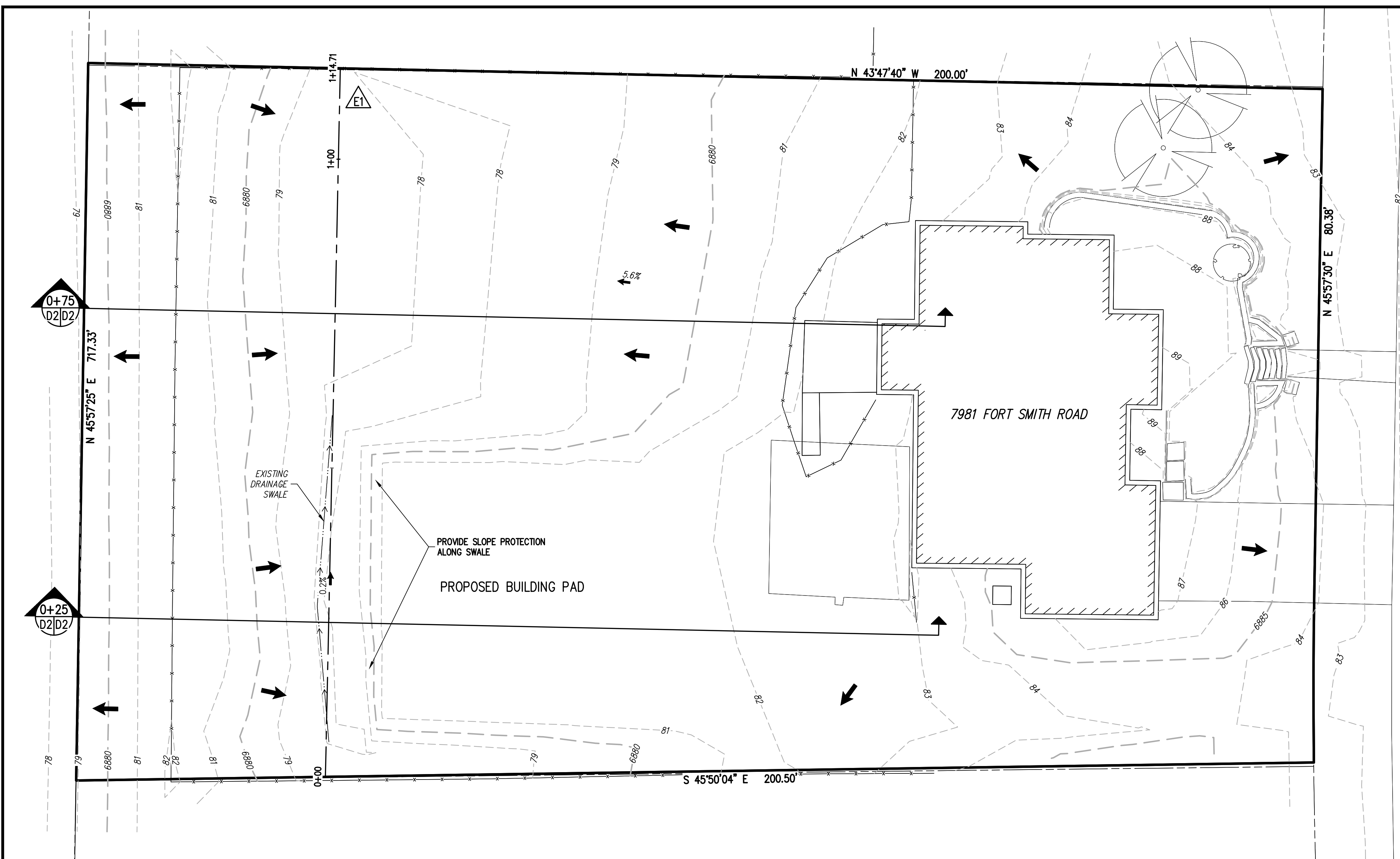

**LEGEND**

EXISTING LINETYPES	PROPOSED LINETYPES	
81	81	MINOR CONTOUR (1' INTERVAL)
5280	5280	MAJOR CONTOUR (5' INTERVAL)
---	---	PROPERTY BOUNDARY
---	---	LOT LINE
---	---	EDGE OF ASPHALT
---	---	EDGE OF GRAVEL
---	---	WIRE FENCE
---	---	EDGE OF BUILDING
---	---	DITCH FLOWLINE
---	---	DRAINAGE BOUNDARY

EXISTING SYMBOLS: PROPOSED SYMBOLS: FLOW DIRECTION, TYPICALLY ON PAVED SURFACES

DESIGN POINT DESIGNATION: A = BASIN DESIGNATION, B = BASIN AREA (ac), C = 100-YR C-FACTOR, D = 5-YR C-FACTOR

**RUNOFF SUMMARY**

BASIN LABEL	DESIGN POINT	AREA	Imp.	C5	C100	LOCAL (CFS)	
						Q5	Q100
E1	E1	14.23	0.45	0.41	0.50	8.4	21.1

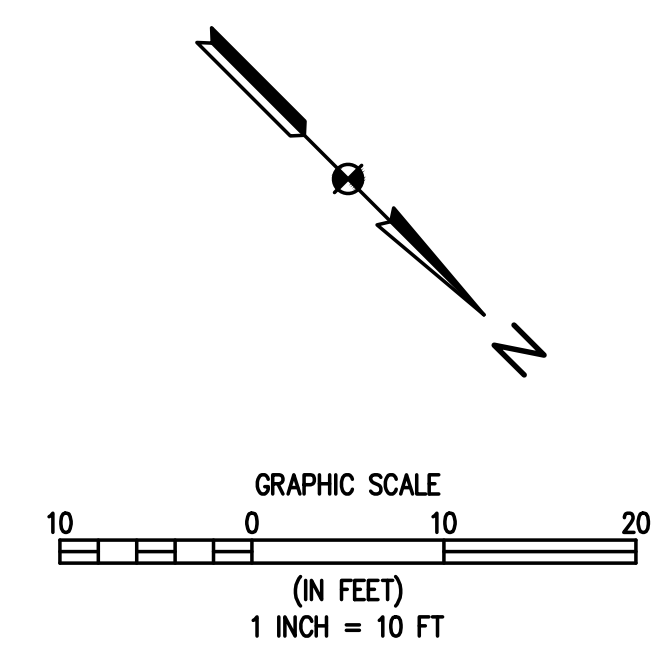
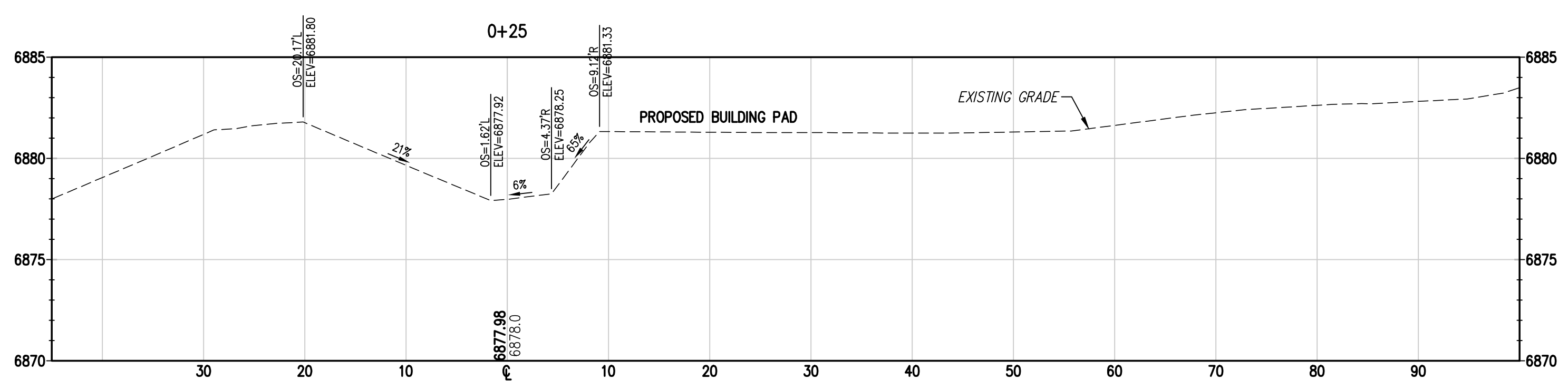
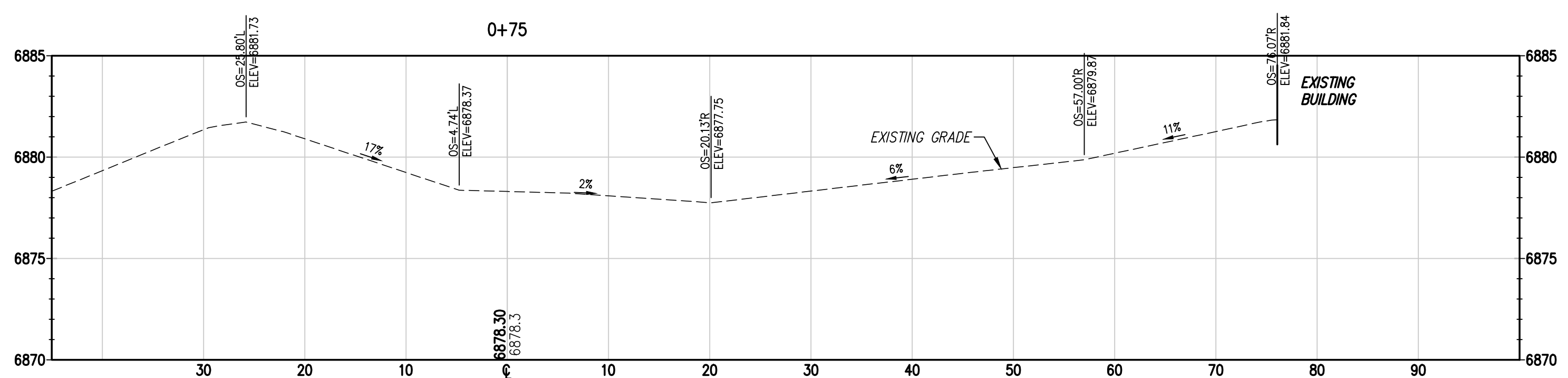

1  
D2  
PROPOSED DRAINAGE PLAN

**BASELINE**  
Engineering - Planning - Surveying  
1046 ELKTON DRIVE • COLORADO SPRINGS, COLORADO 80907  
P. 719.531.6200 • F. 719.531.6266 • www.baselinecorp.com

DESIGNED BY	MAS	DATE	
DRAWN BY	LAR	REVISION DESCRIPTION	
CHECKED BY	NUN	PREPARED BY	

TOWN OF PEYTON  
EL PASO COUNTY  
**JEROME ENGEL**  
FT SMITH RD DRAINAGE LETTER  
7981 FORT SMITH RD  
PROPOSED DRAINAGE PLAN

FOR AND ON BEHALF OF  
BASELINE CORPORATION

INITIAL SUBMITTAL	XX/XX/XX
DRAWING SIZE	24" X 36"
SURVEY FIRM	XX/XX/XX
SURVEY DATE	XX/XX/XX
JOB NO.	C35079CS
DRAWING NAME	35079CS_Drainage Maps.dwg
SHEET	2 OF XX

D2