



MVE, INC.
ENGINEERS SURVEYORS

1903 kelaray street, suite 200
colorado springs, co 80909
719.635.5736

Final Drainage Report

**RMCC Ellicott
Subdivision Filing
No. 1**

Project No. 61182

April 8, 2025

PCD File No. PPR2420

Final Drainage Report

for

RMCC Ellicott Subdivision Filing No. 1

Project No. 61182

April 8, 2025

prepared for

Rocky Mountain Calvary, Inc.

4285 N Academy Blvd
Colorado Springs, CO 80918
719.597.1133

prepared by

MVE, Inc.

1903 Lelaray Street, Suite 200
Colorado Springs, CO 80909
719.635.5736

Copyright © MVE, Inc., 2025
61182-RMCC Ellicott Drainage Report.odt

Statements and Acknowledgments

Engineer's Statement

The attached drainage plan and report were prepared under my direction and supervision and are correct to the best of my knowledge and belief. Said drainage report has been prepared according to the criteria established by the County for drainage reports and said report is in conformity with the applicable master plan of the drainage basin. I accept responsibility for any liability caused by any negligent acts, errors or omissions on my part in preparing this report.

David R. Gorman, P.E.
Colorado No. 31672
For and on Behalf of MVE, Inc.



Developer's Statement

I, the owner/developer have read and will comply with all of the requirements specified in this drainage report and plan.

A handwritten signature in black ink, appearing to read "Rocky Mountain Calvary, Inc.", written over a horizontal line.

Rocky Mountain Calvary, Inc.
4285 N Academy Blvd
Colorado Springs, CO 80918

4-24-25
Date

El Paso County

Filed in accordance with the requirements of the Drainage Criteria Manual, Volumes 1 and 2, El Paso County Engineering Criteria Manual and Land Development Code as amended.

Joshua Palmer, P.E.,
County Engineer / ECM Administrator

Date

Contents

Statements and Acknowledgments.....	iii
Contents.....	v
Final Drainage Report.....	1
1 General Location and Description.....	1
1.1 Location.....	1
1.2 Description of Property.....	1
1.3 Soils.....	1
1.4 Flood Insurance	2
2 Drainage Basins and Sub-Basins.....	2
2.1 Major Basin Descriptions.....	2
2.2 Other Drainage Reports.....	2
2.3 Sub-Basin Description.....	2
3 Drainage Design Criteria.....	2
3.1 Development Criteria Reference.....	2
3.2 Hydrologic Criteria.....	3
4 Drainage Facility Design.....	3
4.1 General Concept.....	3
4.2 Specific Details.....	3
4.3 Erosion Control.....	5
4.4 Water Quality Enhancement Best Management Practices.....	5
5 Opinion of Probable Cost for Drainage Facilities.....	5
6 Drainage and Bridge Fees.....	6

7 Conclusion	6
References.....	7
Appendices.....	9
8 General Maps and Supporting Data	9
9 Hydrologic Calculations	10
10 Hydraulic Calculations	11
11 Report Maps	41

Final Drainage Report

The purpose of this Final Drainage Report is to identify drainage patterns and quantities within and affecting the proposed RMCC Ellicott Subdivision Filing No. 1 site. The report will discuss the recommended drainage improvements to the site and identify drainage requirements relative to the existing conditions and proposed project. This report has been prepared and submitted in accordance with the requirements of the El Paso County development approval process. An Appendix is included with this report with pertinent calculations and graphs used in the drainage analyses and design.

1 General Location and Description

1.1 Location

The proposed RMCC Ellicott Subdivision Filing No. 1 site is a tract of land located in the southeast quarter of the northeast quarter of Section 1, Township 14 south, Range 63 west of the 6th Principal Meridian, El Paso county, Colorado. The property has El Paso County Tax Schedule No. 3400000207. The current address of the site is 2150 North Ellicott Highway.

The site is situated on the west side of existing North Ellicott Highway, approximately a mile and a half North of State Highway 94 in El Paso County. Existing North Ellicott Highway, a paved public roadway, is adjacent to the eastern edge of the site. Lot 1, Cordero Minor Subdivision, zoned A-35 and containing one agricultural residence, borders the site on the north side. Lot 2, Cordero Minor Subdivision, zoned A-35 and containing one agricultural residence borders the site on the west and south sides. An unplatted parcel, zone A-35 is located on the east side of existing North Ellicott Highway opposite the site and contains two (2) mobile homes and one (1) shed. Lot 2, Replat of Lot 1 MUHE Subdivision, zoned A-5 with no existing structures, is also located on the east side of North Ellicott Highway opposite the site. Lot 2, MUHE Subdivision, zoned A-5 and containing one single family residence, is also located on the east side of North Ellicott Highway opposite the site. A **Vicinity Map** is included in the **Appendix**.

1.2 Description of Property

The RMCC Ellicott Subdivision Filing No. 1 site is currently occupied by one (1) one-story building housing the Ellicott Campus of Rocky Mountain Calvary Chapel, a gravel parking lot and a children's playground. The remainder of the site contains natural grass and a few sparse trees. The area of the site is 2.639± acres and it is zoned A-5 (Agricultural 5 Acre).

Ground cover in most of the Lot is undisturbed pasture/meadow conditions with fair to good ground cover featuring native grasses and existing gravel drive and parking areas.

The site slopes from northwest to southeast with grades of approximately 2%. No significant drainageways flow through the site and no significant drainage improvements or drainage facilities currently exist on the site.

1.3 Soils

According to the National Resource Conservation Service, there are two (2) soil type identified in the RMCC Ellicott Subdivision Filing No. 1 site. The primary soil is Ellicott loamy coarse sand, 0 to 5 percent slopes (map unit 28) lying in the west 80% of the site.

Ellicott loamy coarse sand (map unit 28) is deep and somewhat excessively well drained, has rapid permeability, slow surface runoff and high hazard of erosion. Ellicott loamy sand is classified as being part of Hydrologic Soil Group A.

The east 20% of the site is made up of Sampson loam, 0 to 3 percent slopes (map unit 78).

Sampson loam is deep and well drained, has moderate permeability, slow surface runoff and slight hazard of erosion. Sampson loam is classified as being part of Hydrologic Soil Group B.

A portion of the Soil Map and data tables from the National Cooperative Soil Survey and relevant Official Soil Series Descriptions (OSD) are included in the **Appendix**.^{1 2}

1.4 Flood Insurance

The current Flood Insurance Study of the region includes Flood Insurance Rate Maps (FIRM), effective on December 7, 2018.³ The proposed subdivision is included in Community Panel Numbered 08041C0807 G of the Flood Insurance Rate Maps for the El Paso County. No part of the site is shown to be included in a 100-year flood hazard area as determined by FEMA. A portion of the current FEMA Flood Insurance Rate Maps with the site delineated is included in the **Appendix**.

2 Drainage Basins and Sub-Basins

2.1 Major Basin Descriptions

The RMCC Ellicott Subdivision Filing No. 1 site is located in the Hook and Line Ranch Drainage Basin (CHBS1800) of the Black Squirrel Creek Major Drainage Basin (BS). The Hook and Line Ranch Drainage Basin encompasses a portion of El Paso County south of Colorado Springs extending from northwest of Judge Orr Rd and Peyton Highway down to Highway 94 east of Ellicott, generally draining southeasterly into Black Squirrel Creek.

2.2 Other Drainage Reports

No other drainage reports are on file for the areas surrounding RMCC Ellicott Subdivision Filing No. 1.

2.3 Sub-Basin Description

The existing drainage patterns of the RMCC Ellicott Subdivision Filing No. 1 are described by one on-site drainage basin. No off-site flows enter the site from the surrounding properties. All of these basins are previously disturbed or developed to a degree as described below. All existing basin delineations and data are depicted on the attached **Existing Drainage Map**.

2.3.1 Existing Drainage Patterns (Off-Site)

There are no offsite sub-basins that drain into this site.

2.3.2 Existing Drainage Patterns (On-Site)

Existing Sub-Basin EX-A1 (2.64± acres) represents the entirety of the existing site. This sub-basin slopes approximately 1% from northwest to southeast. The flows are generally overland flows and continue southeast off of the south property line near the southeast corner of the site onto the adjacent lot.

3 Drainage Design Criteria

3.1 Development Criteria Reference

This Final Drainage Report for RMCC Ellicott Subdivision Filing No. 1 has been prepared according to the report guidelines presented in the latest edition of *El Paso County Drainage Criteria Manual* (DCM)⁴. The County has also adopted portions of the City of Colorado Springs Drainage Criteria

1 WSS
2 OSD
3 FIRM
4 DCM Section 4.3 and Section 4.4

Manual Volumes 1 and 2, especially concerning the calculation of rainfall runoff flow rates.^{5 6} The hydrologic analysis is based on a collection of data from the DCM, the NRCS Web Soil Survey⁷, and existing topographic data by Polaris Surveying.

3.2 Hydrologic Criteria

For this Final Drainage Report, the Rational Method as described in the *Drainage Criteria Manual* has been used for all Storm Runoff calculations, as the development and all sub-basins are less than 130 acres in area. "Colorado Springs Rainfall Intensity Duration Frequency" curves, Figure 6-5 in the DCM, was used to obtain the design rainfall values; a copy is included in the **Appendix**. The "Overland (Initial) Flow Equation" (Eq. 6-8) in the DCM, and Manning's equation with estimated depths were used in time of concentration calculations. "Runoff Coefficients for Rational Method", Table 6-6 in the DCM, was utilized as a guide in estimating runoff coefficient and Percent Impervious values; a copy is included in the **Appendix**. Peak runoff discharges were calculated for each drainage sub-basin for both the 5-year storm event and the 100-year storm event with the Rational Method formula, (Eq. 6-5) in the DCM.⁸

4 Drainage Facility Design

4.1 General Concept

The intent of the drainage concept presented in this Final Drainage Report is to maintain the existing drainage patterns on the site Major and minor storm flows will continue to be safely conveyed through the site and downstream.

The existing and proposed drainage hydrologic conditions are described in more detail below. Input data and results for all calculations are included in the **Appendix**. Drainage maps for the hydrology are also included in the **Appendix**.

4.2 Specific Details

4.2.1 Existing Hydrologic Conditions

Existing Off-Site Sub-Basin **OS-EXA** (0.39± acres) represents the existing gravel drive north of the site. This sub-basin slopes approximately 1% from southwest to northeast. The flows travel northerly off of the drive then east towards N Ellicott Highway **Design Point 1 (EX DP1)** represents the total flows arriving at the western edge of N. Ellicott Highway The runoff discharges for this design point are $Q_5 = 0.5$ cfs and $Q_{100} = 1.2$ cfs (existing flows) that travel south along the shallow depression west of the highway.

Existing Sub-Basin **EX-A1** (2.64± acres) represents the entirety of the existing site. This sub-basin slopes approximately 1% from northwest to southeast. The majority of the site is pasture / Meadow with a gravel parking area and drive along the north side of the site. There is an existing building of approximately 3,700 sf. in the east central portion of the site. The flows leaving the east side of the site towards N Ellicott Highway travel south and flows leaving the south of the site travel east along the adjacent property's driveway and both join at the southeast corner of the site and continue south off of the south property line onto the adjacent lot.

Design Point 3 (EX DP3) represents the total flows leaving the property and traveling south in the shallow roadside depression along the west edge of N. Ellicott Highway. The runoff discharges for this design point are $Q_5 = 1.6$ cfs and $Q_{100} = 5.8$ cfs (existing flows).

The **Existing Drainage Map** depicts the existing topographic mapping, drainage basin delineations, drainage patterns, existing drives, drainage facilities, and runoff quantities with a data table including drainage areas and flow rates.

5 CS DCM Vol 1

6 CS DCM Vol 2

7 WSS

8 DCM

4.2.2 Proposed Hydrologic Conditions

Off-Site Sub-Basin **OS-PPA** (0.39± acres) represents the existing gravel drive north of the site that will be paved with asphalt as part of this development. This sub-basin slopes approximately 1% from southwest to northeast. The runoff discharges for this sub-basin are $Q_5 = 0.8$ cfs and $Q_{100} = 1.7$ cfs (proposed flows) that travel south along the shallow depression west of the highway. This sub-basin contains the existing gravel drive to be paved and the necessary minor grading required. The paved portion can not feasibly be drained to a water quality facility and is therefore excluded from WQ Treatment per ECM I.7.1.C.1.

Proposed Sub-Basin **A1 (DP1)** (0.34± acres) represents the north portion of the site containing landscape, paved and parking. This sub-basin slopes approximately 1% from west to east. The flows exit the site to the east into N Ellicott Highway then continue south joining with the other on-site flows at **Design Point 3 (DP3)**. Proposed runoff discharges for this sub-basin are $Q_5 = 0.8$ cfs and $Q_{100} = 1.9$ cfs. This sub-basin can not be reasonably directed to the water quality facility or have treatment provided, therefore it is excluded from WQ Treatment per ECM I.7.1.C.1 for the paved areas and by Runoff Reduction for the regraded pervious areas.

Design Point 1 (PP DP1) represents the total flows arriving at the western edge of N. Ellicott Highway east of the site. The runoff discharges for this design point are $Q_5 = 0.8$ cfs and $Q_{100} = 1.7$ cfs (proposed flows) that travel south along the shallow depression west of the highway.

Proposed Sub-Basin **A2** (0.05± acres) represents the west portion of the site containing only pasture / meadow. Flows from the west edge of the site will leave the property and south along the property line in the natural drainage path before turning east and traveling along the adjacent property's driveway where it joins with the other on-site flows at **Design Point 3 (DP3)**. Proposed runoff discharges for this sub-basin are $Q_5 = 0.1$ cfs and $Q_{100} = 0.1$ cfs (proposed flows). This sub-basin consists of only regraded pervious areas and WQ Treatment is provided by Runoff Reduction.

Proposed Sub-Basin **A3** (1.29± acres) represents the majority of the proposed area of the site containing landscape, paved parking, the proposed building and the proposed Full Spectrum Extended Detention Basin (FS-EDB). This sub-basin slopes approximately 1% from northwest to southeast. All flows from this sub-basin are directed to the FS-EDB where it is treated and detained before being piped in a proposed private 8" HDPE storm drain to the southeast corner of the site where it joins with the other on-site flows at **Design Point 3 (DP3)**. Proposed runoff discharges for this sub-basin (**DP2 / Pond In**) are $Q_5 = 2.2$ cfs and $Q_{100} = 4.9$ cfs.

Full Spectrum Extended Detention Basin (Design Point 2/DP2) (1.29 ± acres) is the proposed private Full Spectrum Extended Detention Basin for sub-basin A3. Despite the impervious tributary area being less than 1 acre, an Extended Detention Basin was chosen as the type of facility to provide water quality and detention due to the site's flat nature and lack of a discharge point sufficient in elevation to provide for an understain. The runoff accepted by this pond enters via sheet flow from the parking area and a shallow swale from the northeast. The tributary area of the swale is less than 1 acre and no receiving forebay and associated trickle channel is necessary. Flows from the north half of the building enter the FS-EDB through a roof drain pipe to a riprap pad for concentrated inflow. Emergency overflow flows will be across a spillway along the east side of the pond. This pond accepts storm discharges of $Q_5 = 2.2$ cfs and $Q_{100} = 4.9$ cfs (developed flows) with a discharge rate of $Q_5 = 0.0$ cfs and $Q_{100} = 0.6$ cfs draining into the proposed private 8" HDPE. A deviation shall be requested for an outfall pipe less than 18" due to the shallow grade and lack of pipe cover downstream. This flow existing the pond join with the other on-site flows at **Design Point 3 (DP3)**.

Proposed Sub-Basin **A4** (0.95± acres) represents the majority of the existing developed area of the site containing landscape, gravel parking, the existing building and pasture/meadow. This sub-basin slopes approximately 1% from northwest to southeast. All flows from this sub-basin drain to the southeast corner of the site where it joins with the other on-site flows at **Design Point 3 (DP3)**. Proposed runoff discharges for this sub-basin are $Q_5 = 0.5$ cfs and $Q_{100} = 2.0$ cfs. The majority of this sub-basin is undisturbed by this project and only minimal regrading is proposed. The regraded pervious areas receive WQ Treatment by Runoff Reduction.

Design Point 3 (DP3) represents the total flows leaving the property in the developed conditions and the runoff discharges for this design point are $Q_5 = 1.7$ cfs and $Q_{100} = 5.2$ cfs (developed flows). These developed flows are a change from the existing condition by discharges of $Q_5 = 0.1$ cfs (6%) and a negative $Q_{100} = 0.6$ cfs (-10%).

4.3 Erosion Control

During future construction, control measures (CM's) for erosion control will be employed based on the previously referenced City of Colorado Springs Drainage Criteria Manual Volume 2 and the Erosion Control Plan for the site. During Construction, silt fencing, sediment control logs, vehicle tracking control, concrete washout area will be in place to minimize erosion from the site. Silt Fencing will be placed along the west, south and east portions of the disturbed areas. This will inhibit suspended sediment from leaving the site during construction. Silt fencing is to remain in place until the proposed berms are stabilized and vegetation is reestablished in the other disturbed areas which are to be reseeded. Vehicle tracking control will be placed at the construction access point in the existing driveway connecting to the N Ellicott Highway. CM's will be utilized as deemed necessary by the contractor, engineer, owner, or County inspector and are not limited to the measures described above.

4.4 Water Quality Enhancement Best Management Practices

The Full Spectrum Extended Detention Basin described above will provide storage for the Water Quality Capture Volume (WQCV) for the site. A Grading and Erosion Control Plan for the construction of the site has been prepared in accordance with the provisions of the DCM. Placement of construction stormwater CM's will as required by the plan will limit soil erosion and deposition by stormwater flowing over the site.

The El Paso County Engineering Criteria Manual (Appendix I, Section I.7.2) requires the consideration of a "Four Step Process for receiving water protection that focuses on reducing runoff volumes, treating the water quality capture volume (WQCV), stabilizing drainageways, and implementing long term source controls". The Four Step Process is incorporated in this project and the elements are discussed below.

- 1) Step 1: Employ Runoff Reduction Practices: Runoff Reduction Practices are employed in this project. Impervious surfaces have been reduced as much as practically possible. Minimized Directly Connected Impervious Areas (MDCIA) is employed on the project because runoff passes through the open space meadow areas east and south of the existing building before leaving the site.
- 2) Step 2: Stabilize Drainageways: All drainage paths on the site are stabilized with pavement or appropriate landscape treatment. The water quality ponds are intended to intercept flows from developed areas. Additionally, the pond outflow points will have rip rap protection.
- 3) Step 3: Provide Water Quality Capture Volume (WQCV): Water Quality is provided for the majority of this site via the proposed Full Spectrum Extended Detention Basin as described above. Areas unable to be drained to the pond that undergo disturbance are self treating or excluded from treatment as detailed in Section 4.2.2 above.
- 4) Step 4: Consider Need for Industrial and Commercial BMPs: The site contains no storage of potentially harmful substances or use of potentially harmful substances. No Site Specific or Other Source Control CM's are required.

5 Opinion of Probable Cost for Drainage Facilities

The following cost opinion is for the construction of the required private storm water appurtenances which are non reimbursable. There are no public storm water facilities required.

Opinion of Costs – On-Site Private Storm Water Facilities – Non Reimbursable

• Outlet Structure	= \$10,000
• 274 LF 8" HDPE Drain Pipe @ \$18/LF	= \$ 4,932
• 1 HDPE Flared End-section @ \$108/EA	= \$ 108
• 3.7 tons of VL Riprap @ \$104/Ton	= \$ <u>385</u>
Total =	\$15,425

6 Drainage and Bridge Fees

The RMCC Ellicott Subdivision Filing No. 1 site is located in the Hook and Line Ranch Drainage Basin (CHBS1800) of the Black Squirrel Creek Major Drainage Basin (BS). The Hook and Line Ranch Drainage Basin is an unstudied basin. Fees associated with this basin are Drainage Fees of \$0 per impervious acre and Bridge Fees of \$0 per impervious acre. No drainage or bridge fees are due.

7 Conclusion

This Final Drainage Report presents existing and proposed drainage conditions for the proposed RMCC Ellicott Subdivision Filing No. 1 project. The development will have negligible and inconsequential effects on the existing site drainage and drainage conditions downstream. The proposed project will not, with respect to stormwater runoff, negatively impact the adjacent properties and downstream properties.

References

NRCS Web Soil Survey. United States Department of Agriculture, Natural Resources Conservation Service ("<http://websoilsurvey.nrcs.usda.gov/app/WebSoilSurvey.aspx>", accessed March, 2018).

NRCS Official Soil Series Descriptions. United States Department of Agriculture, Natural Resources Conservation Service ("<http://soils.usda.gov/technical/classification/osd/index.html>", accessed March, 2018).

Flood Insurance Rate Map. Federal Emergency Management Agency, National Flood Insurance Program (Washington D.C.: FEMA, March 17, 1997).

NCSS Web Soil Survey. United States Department of Agriculture, Natural Resources Conservation Service ("<http://websoilsurvey.nrcs.usda.gov/app/WebSoilSurvey.aspx>", accessed May, 2017).

Drainage Criteria Manual Volume 2, Stormwater Quality Policies, Procedures and Best Management Practices (BMPs). City of Colorado Spring Engineering Division (Colorado Springs: , May 2014).

City of Colorado Springs Drainage Criteria Manual, Volume 1. City of Colorado Springs Engineering Division Staff, Matrix Design Group/Wright Water Engineers (Colorado Springs: , May 2014).

City of Colorado Springs/El Paso County Drainage Criteria Manual. City of Colorado Springs, Department of Public Works, Engineering Division; HDR Infrastructure, Inc.; El Paso County, Department of Public Works, Engineering Division (Colorado Springs: City of Colorado Springs, Revised November 1991).

City of Colorado Springs Drainage Criteria Manual Volume 1. City of Colorado Springs Engineering Division with Matrix Design Group and Wright Water Engineers (Colorado Springs, Colorado: , May 2014).

| Appendices

8 General Maps and Supporting Data

- Vicinity Map
- Portions of Flood Insurance Rate Map
- NRCS Soil Map and Tables
- SCS Soil Type Descriptions
- Hydrologic Soil Group Map and Tables

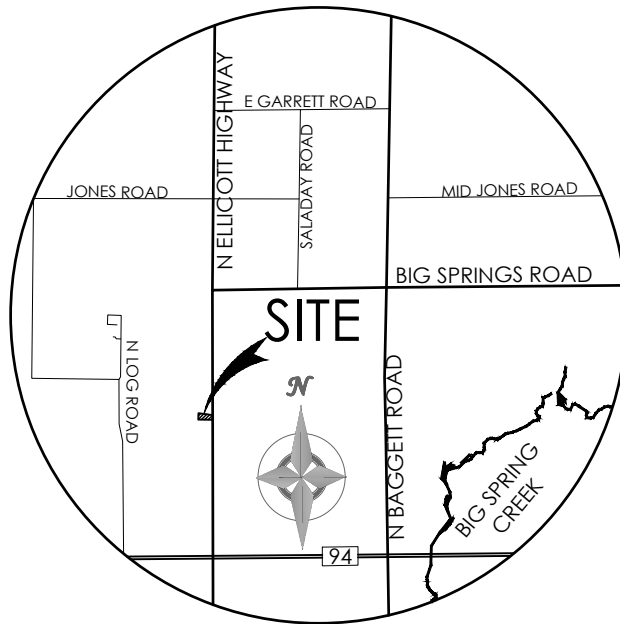

VICINITY MAP

NOT TO SCALE

National Flood Hazard Layer FIRMMette



104°23'35"W 38°51'54"N

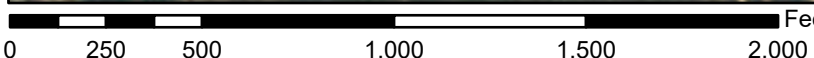
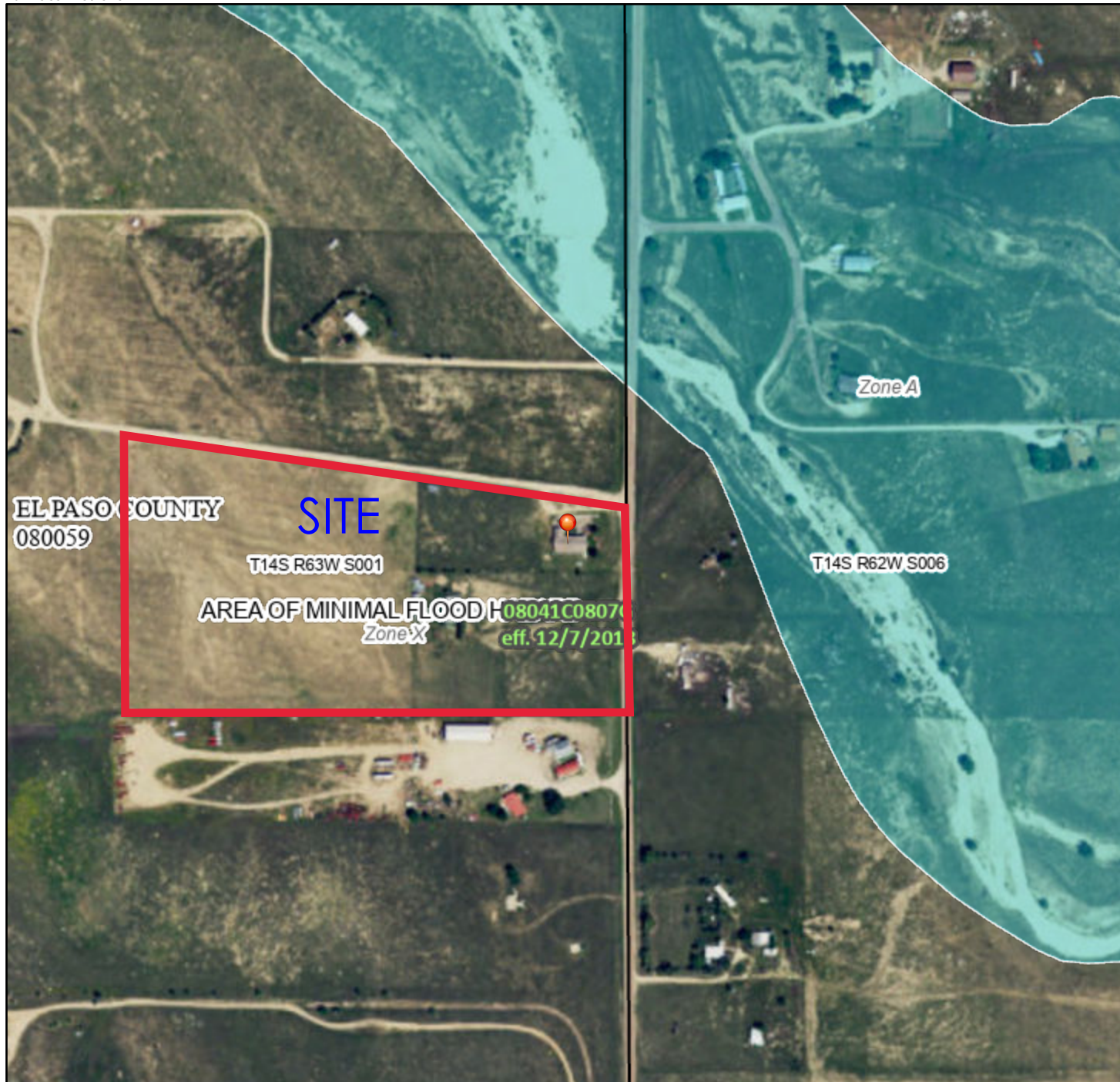

1:6,000

104°22'58"W 38°51'26"N

Basemap: USGS National Map: Orthoimagery: Data refreshed October, 2020

Legend

SEE FIS REPORT FOR DETAILED LEGEND AND INDEX MAP FOR FIRM PANEL LAYOUT

- | | | |
|------------------------------------|--|--|
| SPECIAL FLOOD HAZARD AREAS | | Without Base Flood Elevation (BFE)
<i>Zone A, V, A99</i> |
| | | With BFE or Depth <i>Zone AE, AO, AH, VE, AR</i> |
| | | Regulatory Floodway |
| OTHER AREAS OF FLOOD HAZARD | | 0.2% Annual Chance Flood Hazard, Areas of 1% annual chance flood with average depth less than one foot or with drainage areas of less than one square mile <i>Zone X</i> |
| | | Future Conditions 1% Annual Chance Flood Hazard <i>Zone X</i> |
| | | Area with Reduced Flood Risk due to Levee. See Notes. <i>Zone X</i> |
| | | Area with Flood Risk due to Levee <i>Zone D</i> |
| OTHER AREAS | | NO SCREEN Area of Minimal Flood Hazard <i>Zone X</i> |
| | | Effective LOMRs |
| GENERAL STRUCTURES | | Area of Undetermined Flood Hazard <i>Zone D</i> |
| | | Channel, Culvert, or Storm Sewer |
| | | Levee, Dike, or Floodwall |
| OTHER FEATURES | | 20.2 Cross Sections with 1% Annual Chance Water Surface Elevation
17.5 |
| | | Coastal Transect |
| | | Base Flood Elevation Line (BFE) |
| | | Limit of Study |
| | | Jurisdiction Boundary |
| MAP PANELS | | Digital Data Available |
| | | No Digital Data Available |
| | | Unmapped |
| | | The pin displayed on the map is an approximate point selected by the user and does not represent an authoritative property location. |



This map complies with FEMA's standards for the use of digital flood maps if it is not void as described below. The basemap shown complies with FEMA's basemap accuracy standards

The flood hazard information is derived directly from the authoritative NFHL web services provided by FEMA. This map was exported on 6/1/2023 at 7:30 PM and does not reflect changes or amendments subsequent to this date and time. The NFHL and effective information may change or become superseded by new data over time.

This map image is void if the one or more of the following map elements do not appear: basemap imagery, flood zone labels, legend, scale bar, map creation date, community identifiers, FIRM panel number, and FIRM effective date. Map images for unmapped and unmodernized areas cannot be used for regulatory purposes.

Custom Soil Resource Report for El Paso County Area, Colorado



Preface

Soil surveys contain information that affects land use planning in survey areas. They highlight soil limitations that affect various land uses and provide information about the properties of the soils in the survey areas. Soil surveys are designed for many different users, including farmers, ranchers, foresters, agronomists, urban planners, community officials, engineers, developers, builders, and home buyers. Also, conservationists, teachers, students, and specialists in recreation, waste disposal, and pollution control can use the surveys to help them understand, protect, or enhance the environment.

Various land use regulations of Federal, State, and local governments may impose special restrictions on land use or land treatment. Soil surveys identify soil properties that are used in making various land use or land treatment decisions. The information is intended to help the land users identify and reduce the effects of soil limitations on various land uses. The landowner or user is responsible for identifying and complying with existing laws and regulations.

Although soil survey information can be used for general farm, local, and wider area planning, onsite investigation is needed to supplement this information in some cases. Examples include soil quality assessments (<http://www.nrcs.usda.gov/wps/portal/nrcs/main/soils/health/>) and certain conservation and engineering applications. For more detailed information, contact your local USDA Service Center (<https://offices.sc.egov.usda.gov/locator/app?agency=nrcs>) or your NRCS State Soil Scientist (http://www.nrcs.usda.gov/wps/portal/nrcs/detail/soils/contactus/?cid=nrcs142p2_053951).

Great differences in soil properties can occur within short distances. Some soils are seasonally wet or subject to flooding. Some are too unstable to be used as a foundation for buildings or roads. Clayey or wet soils are poorly suited to use as septic tank absorption fields. A high water table makes a soil poorly suited to basements or underground installations.

The National Cooperative Soil Survey is a joint effort of the United States Department of Agriculture and other Federal agencies, State agencies including the Agricultural Experiment Stations, and local agencies. The Natural Resources Conservation Service (NRCS) has leadership for the Federal part of the National Cooperative Soil Survey.

Information about soils is updated periodically. Updated information is available through the NRCS Web Soil Survey, the site for official soil survey information.

The U.S. Department of Agriculture (USDA) prohibits discrimination in all its programs and activities on the basis of race, color, national origin, age, disability, and where applicable, sex, marital status, familial status, parental status, religion, sexual orientation, genetic information, political beliefs, reprisal, or because all or a part of an individual's income is derived from any public assistance program. (Not all prohibited bases apply to all programs.) Persons with disabilities who require

alternative means for communication of program information (Braille, large print, audiotape, etc.) should contact USDA's TARGET Center at (202) 720-2600 (voice and TDD). To file a complaint of discrimination, write to USDA, Director, Office of Civil Rights, 1400 Independence Avenue, S.W., Washington, D.C. 20250-9410 or call (800) 795-3272 (voice) or (202) 720-6382 (TDD). USDA is an equal opportunity provider and employer.

Contents

Preface	2
How Soil Surveys Are Made	5
Soil Map	8
Soil Map.....	9
Legend.....	10
Map Unit Legend.....	11
Map Unit Descriptions.....	11
El Paso County Area, Colorado.....	13
28—Ellicott loamy coarse sand, 0 to 5 percent slopes.....	13
78—Sampson loam, 0 to 3 percent slopes.....	14
References	16

How Soil Surveys Are Made

Soil surveys are made to provide information about the soils and miscellaneous areas in a specific area. They include a description of the soils and miscellaneous areas and their location on the landscape and tables that show soil properties and limitations affecting various uses. Soil scientists observed the steepness, length, and shape of the slopes; the general pattern of drainage; the kinds of crops and native plants; and the kinds of bedrock. They observed and described many soil profiles. A soil profile is the sequence of natural layers, or horizons, in a soil. The profile extends from the surface down into the unconsolidated material in which the soil formed or from the surface down to bedrock. The unconsolidated material is devoid of roots and other living organisms and has not been changed by other biological activity.

Currently, soils are mapped according to the boundaries of major land resource areas (MLRAs). MLRAs are geographically associated land resource units that share common characteristics related to physiography, geology, climate, water resources, soils, biological resources, and land uses (USDA, 2006). Soil survey areas typically consist of parts of one or more MLRA.

The soils and miscellaneous areas in a survey area occur in an orderly pattern that is related to the geology, landforms, relief, climate, and natural vegetation of the area. Each kind of soil and miscellaneous area is associated with a particular kind of landform or with a segment of the landform. By observing the soils and miscellaneous areas in the survey area and relating their position to specific segments of the landform, a soil scientist develops a concept, or model, of how they were formed. Thus, during mapping, this model enables the soil scientist to predict with a considerable degree of accuracy the kind of soil or miscellaneous area at a specific location on the landscape.

Commonly, individual soils on the landscape merge into one another as their characteristics gradually change. To construct an accurate soil map, however, soil scientists must determine the boundaries between the soils. They can observe only a limited number of soil profiles. Nevertheless, these observations, supplemented by an understanding of the soil-vegetation-landscape relationship, are sufficient to verify predictions of the kinds of soil in an area and to determine the boundaries.

Soil scientists recorded the characteristics of the soil profiles that they studied. They noted soil color, texture, size and shape of soil aggregates, kind and amount of rock fragments, distribution of plant roots, reaction, and other features that enable them to identify soils. After describing the soils in the survey area and determining their properties, the soil scientists assigned the soils to taxonomic classes (units). Taxonomic classes are concepts. Each taxonomic class has a set of soil characteristics with precisely defined limits. The classes are used as a basis for comparison to classify soils systematically. Soil taxonomy, the system of taxonomic classification used in the United States, is based mainly on the kind and character of soil properties and the arrangement of horizons within the profile. After the soil

Custom Soil Resource Report

scientists classified and named the soils in the survey area, they compared the individual soils with similar soils in the same taxonomic class in other areas so that they could confirm data and assemble additional data based on experience and research.

The objective of soil mapping is not to delineate pure map unit components; the objective is to separate the landscape into landforms or landform segments that have similar use and management requirements. Each map unit is defined by a unique combination of soil components and/or miscellaneous areas in predictable proportions. Some components may be highly contrasting to the other components of the map unit. The presence of minor components in a map unit in no way diminishes the usefulness or accuracy of the data. The delineation of such landforms and landform segments on the map provides sufficient information for the development of resource plans. If intensive use of small areas is planned, onsite investigation is needed to define and locate the soils and miscellaneous areas.

Soil scientists make many field observations in the process of producing a soil map. The frequency of observation is dependent upon several factors, including scale of mapping, intensity of mapping, design of map units, complexity of the landscape, and experience of the soil scientist. Observations are made to test and refine the soil-landscape model and predictions and to verify the classification of the soils at specific locations. Once the soil-landscape model is refined, a significantly smaller number of measurements of individual soil properties are made and recorded. These measurements may include field measurements, such as those for color, depth to bedrock, and texture, and laboratory measurements, such as those for content of sand, silt, clay, salt, and other components. Properties of each soil typically vary from one point to another across the landscape.

Observations for map unit components are aggregated to develop ranges of characteristics for the components. The aggregated values are presented. Direct measurements do not exist for every property presented for every map unit component. Values for some properties are estimated from combinations of other properties.

While a soil survey is in progress, samples of some of the soils in the area generally are collected for laboratory analyses and for engineering tests. Soil scientists interpret the data from these analyses and tests as well as the field-observed characteristics and the soil properties to determine the expected behavior of the soils under different uses. Interpretations for all of the soils are field tested through observation of the soils in different uses and under different levels of management. Some interpretations are modified to fit local conditions, and some new interpretations are developed to meet local needs. Data are assembled from other sources, such as research information, production records, and field experience of specialists. For example, data on crop yields under defined levels of management are assembled from farm records and from field or plot experiments on the same kinds of soil.

Predictions about soil behavior are based not only on soil properties but also on such variables as climate and biological activity. Soil conditions are predictable over long periods of time, but they are not predictable from year to year. For example, soil scientists can predict with a fairly high degree of accuracy that a given soil will have a high water table within certain depths in most years, but they cannot predict that a high water table will always be at a specific level in the soil on a specific date.

After soil scientists located and identified the significant natural bodies of soil in the survey area, they drew the boundaries of these bodies on aerial photographs and

Custom Soil Resource Report

identified each as a specific map unit. Aerial photographs show trees, buildings, fields, roads, and rivers, all of which help in locating boundaries accurately.

Soil Map

The soil map section includes the soil map for the defined area of interest, a list of soil map units on the map and extent of each map unit, and cartographic symbols displayed on the map. Also presented are various metadata about data used to produce the map, and a description of each soil map unit.

Custom Soil Resource Report Soil Map



Map Scale: 1:945 if printed on A landscape (11" x 8.5") sheet.

0 10 20 40 60 Meters

0 45 90 180 270 Feet

Map projection: Web Mercator Corner coordinates: WGS84 Edge tics: UTM Zone 13N WGS84



MAP LEGEND

Area of Interest (AOI)

 Area of Interest (AOI)



















Soils







 Soil Map Unit Polygons

 Soil Map Unit Lines

 Soil Map Unit Points

Special Point Features





-  Blowout
-  Borrow Pit
-  Clay Spot
-  Closed Depression
-  Gravel Pit
-  Gravelly Spot
-  Landfill
-  Lava Flow
-  Marsh or swamp
-  Mine or Quarry
-  Miscellaneous Water
-  Perennial Water
-  Rock Outcrop
-  Saline Spot
-  Sandy Spot
-  Severely Eroded Spot
-  Sinkhole
-  Slide or Slip
-  Sodic Spot

-  Spoil Area
-  Stony Spot
-  Very Stony Spot
-  Wet Spot
-  Other
-  Special Line Features

Water Features

 Streams and Canals

Transportation

-  Rails
-  Interstate Highways
-  US Routes
-  Major Roads
-  Local Roads

Background

 Aerial Photography

MAP INFORMATION

The soil surveys that comprise your AOI were mapped at 1:24,000.

Warning: Soil Map may not be valid at this scale.

Enlargement of maps beyond the scale of mapping can cause misunderstanding of the detail of mapping and accuracy of soil line placement. The maps do not show the small areas of contrasting soils that could have been shown at a more detailed scale.

Please rely on the bar scale on each map sheet for map measurements.

Source of Map: Natural Resources Conservation Service
 Web Soil Survey URL:
 Coordinate System: Web Mercator (EPSG:3857)

Maps from the Web Soil Survey are based on the Web Mercator projection, which preserves direction and shape but distorts distance and area. A projection that preserves area, such as the Albers equal-area conic projection, should be used if more accurate calculations of distance or area are required.

This product is generated from the USDA-NRCS certified data as of the version date(s) listed below.

Soil Survey Area: El Paso County Area, Colorado
 Survey Area Data: Version 19, Aug 31, 2021

Soil map units are labeled (as space allows) for map scales 1:50,000 or larger.

Date(s) aerial images were photographed: Sep 11, 2018—Oct 20, 2018

The orthophoto or other base map on which the soil lines were compiled and digitized probably differs from the background imagery displayed on these maps. As a result, some minor shifting of map unit boundaries may be evident.

Map Unit Legend

Map Unit Symbol	Map Unit Name	Acres in AOI	Percent of AOI
28	Ellicott loamy coarse sand, 0 to 5 percent slopes	2.2	80.4%
78	Sampson loam, 0 to 3 percent slopes	0.5	19.6%
Totals for Area of Interest		2.8	100.0%

Map Unit Descriptions

The map units delineated on the detailed soil maps in a soil survey represent the soils or miscellaneous areas in the survey area. The map unit descriptions, along with the maps, can be used to determine the composition and properties of a unit.

A map unit delineation on a soil map represents an area dominated by one or more major kinds of soil or miscellaneous areas. A map unit is identified and named according to the taxonomic classification of the dominant soils. Within a taxonomic class there are precisely defined limits for the properties of the soils. On the landscape, however, the soils are natural phenomena, and they have the characteristic variability of all natural phenomena. Thus, the range of some observed properties may extend beyond the limits defined for a taxonomic class. Areas of soils of a single taxonomic class rarely, if ever, can be mapped without including areas of other taxonomic classes. Consequently, every map unit is made up of the soils or miscellaneous areas for which it is named and some minor components that belong to taxonomic classes other than those of the major soils.

Most minor soils have properties similar to those of the dominant soil or soils in the map unit, and thus they do not affect use and management. These are called noncontrasting, or similar, components. They may or may not be mentioned in a particular map unit description. Other minor components, however, have properties and behavioral characteristics divergent enough to affect use or to require different management. These are called contrasting, or dissimilar, components. They generally are in small areas and could not be mapped separately because of the scale used. Some small areas of strongly contrasting soils or miscellaneous areas are identified by a special symbol on the maps. If included in the database for a given area, the contrasting minor components are identified in the map unit descriptions along with some characteristics of each. A few areas of minor components may not have been observed, and consequently they are not mentioned in the descriptions, especially where the pattern was so complex that it was impractical to make enough observations to identify all the soils and miscellaneous areas on the landscape.

The presence of minor components in a map unit in no way diminishes the usefulness or accuracy of the data. The objective of mapping is not to delineate pure taxonomic classes but rather to separate the landscape into landforms or landform segments that have similar use and management requirements. The delineation of such segments on the map provides sufficient information for the development of resource plans. If intensive use of small areas is planned, however,

Custom Soil Resource Report

onsite investigation is needed to define and locate the soils and miscellaneous areas.

An identifying symbol precedes the map unit name in the map unit descriptions. Each description includes general facts about the unit and gives important soil properties and qualities.

Soils that have profiles that are almost alike make up a *soil series*. Except for differences in texture of the surface layer, all the soils of a series have major horizons that are similar in composition, thickness, and arrangement.

Soils of one series can differ in texture of the surface layer, slope, stoniness, salinity, degree of erosion, and other characteristics that affect their use. On the basis of such differences, a soil series is divided into *soil phases*. Most of the areas shown on the detailed soil maps are phases of soil series. The name of a soil phase commonly indicates a feature that affects use or management. For example, Alpha silt loam, 0 to 2 percent slopes, is a phase of the Alpha series.

Some map units are made up of two or more major soils or miscellaneous areas. These map units are complexes, associations, or undifferentiated groups.

A *complex* consists of two or more soils or miscellaneous areas in such an intricate pattern or in such small areas that they cannot be shown separately on the maps. The pattern and proportion of the soils or miscellaneous areas are somewhat similar in all areas. Alpha-Beta complex, 0 to 6 percent slopes, is an example.

An *association* is made up of two or more geographically associated soils or miscellaneous areas that are shown as one unit on the maps. Because of present or anticipated uses of the map units in the survey area, it was not considered practical or necessary to map the soils or miscellaneous areas separately. The pattern and relative proportion of the soils or miscellaneous areas are somewhat similar. Alpha-Beta association, 0 to 2 percent slopes, is an example.

An *undifferentiated group* is made up of two or more soils or miscellaneous areas that could be mapped individually but are mapped as one unit because similar interpretations can be made for use and management. The pattern and proportion of the soils or miscellaneous areas in a mapped area are not uniform. An area can be made up of only one of the major soils or miscellaneous areas, or it can be made up of all of them. Alpha and Beta soils, 0 to 2 percent slopes, is an example.

Some surveys include *miscellaneous areas*. Such areas have little or no soil material and support little or no vegetation. Rock outcrop is an example.

El Paso County Area, Colorado

28—Ellicott loamy coarse sand, 0 to 5 percent slopes

Map Unit Setting

National map unit symbol: 3680
Elevation: 5,500 to 6,500 feet
Mean annual precipitation: 13 to 15 inches
Mean annual air temperature: 47 to 50 degrees F
Frost-free period: 125 to 145 days
Farmland classification: Not prime farmland

Map Unit Composition

Ellicott and similar soils: 97 percent
Minor components: 3 percent
Estimates are based on observations, descriptions, and transects of the mapunit.

Description of Ellicott

Setting

Landform: Flood plains, stream terraces
Landform position (three-dimensional): Tread
Down-slope shape: Linear
Across-slope shape: Linear
Parent material: Sandy alluvium

Typical profile

A - 0 to 4 inches: loamy coarse sand
C - 4 to 60 inches: stratified coarse sand to sandy loam

Properties and qualities

Slope: 0 to 5 percent
Depth to restrictive feature: More than 80 inches
Drainage class: Somewhat excessively drained
Runoff class: Very low
Capacity of the most limiting layer to transmit water (Ksat): High to very high (5.95 to 19.98 in/hr)
Depth to water table: More than 80 inches
Frequency of flooding: FrequentNone
Frequency of ponding: None
Available water supply, 0 to 60 inches: Low (about 4.1 inches)

Interpretive groups

Land capability classification (irrigated): None specified
Land capability classification (nonirrigated): 7w
Hydrologic Soil Group: A
Ecological site: R069XY031CO - Sandy Bottomland LRU's A and B
Other vegetative classification: SANDY BOTTOMLAND (069AY031CO)
Hydric soil rating: No

Minor Components

Fluvaquentic haplaquoll

Percent of map unit: 1 percent
Landform: Swales
Hydric soil rating: Yes

Other soils

Percent of map unit: 1 percent
Hydric soil rating: No

Pleasant

Percent of map unit: 1 percent
Landform: Depressions
Hydric soil rating: Yes

78—Sampson loam, 0 to 3 percent slopes

Map Unit Setting

National map unit symbol: 369s
Elevation: 5,500 to 6,500 feet
Mean annual precipitation: 13 to 15 inches
Mean annual air temperature: 47 to 50 degrees F
Frost-free period: 135 to 155 days
Farmland classification: Prime farmland if irrigated

Map Unit Composition

Sampson and similar soils: 95 percent
Minor components: 5 percent
Estimates are based on observations, descriptions, and transects of the mapunit.

Description of Sampson

Setting

Landform: Depressions, alluvial fans, terraces
Down-slope shape: Linear
Across-slope shape: Linear
Parent material: Alluvium

Typical profile

A - 0 to 15 inches: loam
Bt - 15 to 34 inches: clay loam
Bk - 34 to 60 inches: sandy clay loam

Properties and qualities

Slope: 0 to 3 percent
Depth to restrictive feature: More than 80 inches
Drainage class: Well drained
Runoff class: Low
Capacity of the most limiting layer to transmit water (Ksat): Moderately high to high
(0.60 to 2.00 in/hr)
Depth to water table: More than 80 inches
Frequency of flooding: None
Frequency of ponding: None
Calcium carbonate, maximum content: 15 percent
Maximum salinity: Nonsaline to very slightly saline (0.0 to 2.0 mmhos/cm)
Available water supply, 0 to 60 inches: High (about 9.2 inches)

Custom Soil Resource Report

Interpretive groups

Land capability classification (irrigated): 2e

Land capability classification (nonirrigated): 3c

Hydrologic Soil Group: B

Ecological site: R049XB202CO - Loamy Foothill

Hydric soil rating: No

Minor Components

Other soils

Percent of map unit: 4 percent

Hydric soil rating: No

Pleasant

Percent of map unit: 1 percent

Landform: Depressions

Hydric soil rating: Yes

References

- American Association of State Highway and Transportation Officials (AASHTO). 2004. Standard specifications for transportation materials and methods of sampling and testing. 24th edition.
- American Society for Testing and Materials (ASTM). 2005. Standard classification of soils for engineering purposes. ASTM Standard D2487-00.
- Cowardin, L.M., V. Carter, F.C. Golet, and E.T. LaRoe. 1979. Classification of wetlands and deep-water habitats of the United States. U.S. Fish and Wildlife Service FWS/OBS-79/31.
- Federal Register. July 13, 1994. Changes in hydric soils of the United States.
- Federal Register. September 18, 2002. Hydric soils of the United States.
- Hurt, G.W., and L.M. Vasilas, editors. Version 6.0, 2006. Field indicators of hydric soils in the United States.
- National Research Council. 1995. Wetlands: Characteristics and boundaries.
- Soil Survey Division Staff. 1993. Soil survey manual. Soil Conservation Service. U.S. Department of Agriculture Handbook 18. http://www.nrcs.usda.gov/wps/portal/nrcs/detail/national/soils/?cid=nrcs142p2_054262
- Soil Survey Staff. 1999. Soil taxonomy: A basic system of soil classification for making and interpreting soil surveys. 2nd edition. Natural Resources Conservation Service, U.S. Department of Agriculture Handbook 436. http://www.nrcs.usda.gov/wps/portal/nrcs/detail/national/soils/?cid=nrcs142p2_053577
- Soil Survey Staff. 2010. Keys to soil taxonomy. 11th edition. U.S. Department of Agriculture, Natural Resources Conservation Service. http://www.nrcs.usda.gov/wps/portal/nrcs/detail/national/soils/?cid=nrcs142p2_053580
- Tiner, R.W., Jr. 1985. Wetlands of Delaware. U.S. Fish and Wildlife Service and Delaware Department of Natural Resources and Environmental Control, Wetlands Section.
- United States Army Corps of Engineers, Environmental Laboratory. 1987. Corps of Engineers wetlands delineation manual. Waterways Experiment Station Technical Report Y-87-1.
- United States Department of Agriculture, Natural Resources Conservation Service. National forestry manual. http://www.nrcs.usda.gov/wps/portal/nrcs/detail/soils/home/?cid=nrcs142p2_053374
- United States Department of Agriculture, Natural Resources Conservation Service. National range and pasture handbook. <http://www.nrcs.usda.gov/wps/portal/nrcs/detail/national/landuse/rangepasture/?cid=stelprdb1043084>

Custom Soil Resource Report

United States Department of Agriculture, Natural Resources Conservation Service. National soil survey handbook, title 430-VI. http://www.nrcs.usda.gov/wps/portal/nrcs/detail/soils/scientists/?cid=nrcs142p2_054242

United States Department of Agriculture, Natural Resources Conservation Service. 2006. Land resource regions and major land resource areas of the United States, the Caribbean, and the Pacific Basin. U.S. Department of Agriculture Handbook 296. http://www.nrcs.usda.gov/wps/portal/nrcs/detail/national/soils/?cid=nrcs142p2_053624

United States Department of Agriculture, Soil Conservation Service. 1961. Land capability classification. U.S. Department of Agriculture Handbook 210. http://www.nrcs.usda.gov/Internet/FSE_DOCUMENTS/nrcs142p2_052290.pdf

Woodland wildlife, such as mule deer and wild turkey, is attracted to this soil because of its potential to produce ponderosa pine, Gambel oak, and various grasses and shrubs. Water developments, such as guzzlers, would enhance populations of wild turkey as well as other kinds of wildlife. Where wildlife and livestock share the same range, proper grazing management is needed to prevent overuse and to reduce competition. Livestock watering facilities would also benefit wildlife on this soil.

This soil has good potential for use as homesites. The main limitation is the moderate shrink-swell potential in the subsoil and frost action potential. Special road design is necessary on this soil to overcome these limitations. Slope is also a limitation. Special planning is needed on this soil to minimize site disturbance and tree and seedling damage. During seasons of low precipitation, fire may become a hazard to homesites on this soil. The hazard can be minimized by installing firebreaks and reducing the amount of potential fuel on the forest floor. Capability subclass VIe.

27—Elbeth-Pring complex, 5 to 30 percent slopes. These moderately sloping to steep soils are on upland side slopes and ridges. Elevation ranges from 7,200 to 7,400 feet. The average annual precipitation is about 18 inches, the average annual air temperature is about 43 degrees F, and the average frost-free period is about 120 days.

The Elbeth soil makes up about 60 percent of the complex, the Pring about 20 percent, and other soils about 20 percent. The Elbeth soil has slopes of 5 to 15 percent, and the Pring soil has slopes of 5 to 30 percent.

Included with these soils in mapping are areas of Peyton-Pring complex, 8 to 15 percent slopes, Kettle-Rock outcrop complex, and ridges that are covered with gravel and cobbles.

The Elbeth soil is deep and well drained. It formed in material transported from arkose deposits. Typically, the surface layer is very dark grayish brown sandy loam about 3 inches thick. The subsurface layer is light gray loamy sand about 20 inches thick. The subsoil is brown sandy clay loam about 45 inches thick. The substratum is light brown sandy clay loam.

Permeability of the Elbeth soil is moderate. Effective rooting depth is 60 inches or more. Available water capacity is high. Surface runoff is medium to rapid, and the hazard of erosion is moderate to high. Deep gullies occur throughout areas of this soil. Some soil slippage occurs on some of the steeper slopes.

The Pring soil is deep and well drained. It formed in arkosic sediment. Typically, the surface layer is dark grayish brown coarse sandy loam about 4 inches thick. The next layer is dark grayish brown coarse sandy loam about 10 inches thick. The underlying material is pale brown gravelly sandy loam to a depth of 60 inches.

Permeability of the Pring soil is rapid. Effective rooting depth is 60 inches or more. Available water capacity is moderate. Surface runoff is medium, and the hazard of erosion is moderate.

The soils in this complex are used for woodland, recreation, livestock grazing, and homesites.

The Elbeth soil is suited to the production of ponderosa pine. It is capable of producing about 2,240 cubic feet, or 4,900 board feet (International rule), of merchantable timber per acre from a fully stocked, even-aged stand of 80-year-old trees. Conventional methods can be used for harvesting, but operations may be restricted during wet periods. Reforestation, after harvesting, must be carefully managed to reduce competition of undesirable understory plants.

The Pring soil is suited to the production of native vegetation suitable for grazing by cattle and sheep. Rangeland vegetation is mainly mountain muhly, little bluestem, needleandthread, Parry oatgrass, and junegrass.

Deferment of grazing in spring promotes plant vigor and reproduction of the cool-season bunchgrasses. Fencing and proper location of livestock watering facilities may be needed to obtain proper distribution of grazing. Locating salt blocks in areas not generally grazed increases the use of the available forage.

Woodland wildlife such as mule deer and wild turkey is attracted to the Elbeth soil because of its potential to produce ponderosa pine, Gambel oak, and various grasses and shrubs. Water developments, such as guzzlers, would enhance populations of wild turkey as well as other kinds of wildlife. Where wildlife and livestock share the same range, proper grazing management is needed to prevent overuse and to reduce competition. Livestock watering facilities would also benefit wildlife on this soil.

The Pring soil is suited to wildlife habitat. It is best suited to habitat for openland and rangeland wildlife. Rangeland wildlife, such as pronghorn antelope, can be encouraged by developing livestock watering facilities, properly managing livestock grazing, and reseeding range where needed.

The main limitations of this complex for construction are the moderate shrink-swell potential in the subsoil of the Elbeth soil and the steep slopes of both soils. Special site or building designs for dwellings and roads are required to offset these limitations. Special practices must be used to minimize surface runoff and keep soil erosion to a minimum. Capability subclass VIe.

28—Ellicott loamy coarse sand, 0 to 5 percent slopes. This deep, somewhat excessively drained soil is on terraces and flood plains (fig. 1). The average annual precipitation is about 14 inches, the average annual air temperature is about 48 degrees F, and the average frost-free period is about 135 days.

Typically, the surface layer is grayish brown loamy coarse sand about 4 inches thick. The underlying material to a depth of 60 inches is light brownish gray coarse sand stratified with layers of loamy sand, loamy coarse sand, and coarse sandy loam.

Included with this soil in mapping are small areas of Ustic Torrifluvents, loamy; Fluvaquent Haploquolls, nearly level; Blakeland loamy sand, 1 to 9 percent slopes; Blendon sandy loam; and Truckton sandy loam, 0 to 3 percent slopes.

Permeability of this Ellicott soil is rapid. Effective rooting depth is 60 inches or more. Available water capacity is low. Surface runoff is slow, the hazard of erosion is high, and the hazard of soil blowing is moderate.

Almost all areas of this soil are used as rangeland.

The rangeland vegetation on this soil is mainly switchgrass, needleandthread, sand bluestem, and prairie sand reedgrass.

Seeding is a good practice if the range is in poor condition. Seeding of the native grasses is desirable. Yellow or white sweetclover may be added to the seeding mixture to provide a source of nitrogen for the grasses. Too much clover can create a danger of bloat by grazing animals. This soil is subject to flooding and should be managed to keep a heavy cover of grass to protect the soil. Fencing is a necessary practice in range management. Brush control and grazing management may help to improve deteriorated range.

Windbreaks and environmental plantings are fairly well suited to this soil. Blowing sand and low available water capacity are the principal limitations for the establishment of trees and shrubs. The soil is so loose that trees need to be planted in shallow furrows and plant cover needs to be maintained between the rows. Supplemental irrigation may be needed to insure survival of trees. Trees that are best suited and have good survival are Rocky Mountain juniper, eastern redcedar, ponderosa pine, and Siberian elm. Shrubs that are best suited to skunkbush sumac, lilac, and Siberian peashrub.

Rangeland wildlife, such as antelope, cottontail, coyote, and scaled quail, is best adapted to life on this droughty soil. Forage production is typically low, and proper livestock grazing management is needed if wildlife and livestock share the range. Livestock watering developments are also important and are used by various wildlife species.

The main limitation of this soil for construction is the hazard of flooding. All construction on this soil should be kept off the flood plain as much as possible. Capability subclass VIw.

29—Fluvaquentic Haplaquolls, nearly level. These deep, poorly drained soils are in marshes, in swales, and on creek bottoms. The average annual precipitation is about 14 inches, and the average annual air temperature is about 47 degrees F.

Included with these soils in mapping are small areas of Ustic Torrifluvents, loamy; Blakeland loamy sand, 1 to 9 percent slopes; Columbine gravelly sandy loam, 0 to 3 percent slopes; and Ellicott loamy coarse sand, 0 to 5 percent slopes.

These soils are stratified. Typically, the surface layer is light gray to very dark gray loamy fine sand to gravelly loam 2 to 6 inches thick. The underlying material, 48 to 58 inches thick, is very pale brown to gray, stratified heavy sandy clay loam to sand and gravel. The lower part of some of the soils, at depths ranging from 18 to 48 inches, ranges from light blueish gray to greenish gray. The water table is usually at a depth of less than 48 inches, and it is on the surface during part of the year.

Permeability of these soils is moderate. Effective rooting depth is limited by the water table. Available water capacity is moderate. Surface runoff is slow, and the hazard of erosion is slight. At times overflow deposits a damaging amount of silt and sand in the lower lying areas.

These soils are in meadow. They are used for native hay or for grazing.

These soils are well suited to the production of native vegetation suitable for grazing. The vegetation is mainly switchgrass, indiangrass, sedges, rushes, prairie cordgrass, western wheatgrass, and bluegrass. Cattails and bulrushes commonly grow in the swampy areas.

Management of distribution of livestock and stocking rates is necessary on these soils to avoid abuse of the range. In large areas, fences should be used to control grazing.

Wetland wildlife can be attracted to these soils and the wetland habitat enhanced by several means. Shallow water developments can be created by digging or by blasting potholes to create open-water areas. Fencing to control livestock use is beneficial, and it allows wetland plants such as cattails, reed canarygrass, and rushes to grow. Control of unplanned burning and prevention of drainage that would remove water from the wetlands are also good practices. These shallow marsh areas are often especially important for winter cover if natural vegetation is allowed to grow.

These soils are severely limited for use as homesites. The main limitations are a high water table and a hazard of periodic flooding. Community sewerage systems are needed because the high water table prevents septic tank absorption fields from functioning properly. Roads must also be designed to prevent frost-heave damage. Capability subclass Vw.

30—Fort Collins loam, 0 to 3 percent slopes. This deep, well drained soil formed in medium textured alluvium on uplands. Elevation ranges from 5,200 to 6,500 feet. The average annual precipitation ranges from about 13 inches at the lower elevations to about 15 inches at the higher elevations; the average annual temperature is about 49 degrees F; and the average frost-free period is about 145 days.

Typically, the surface layer is brown loam about 6 inches thick. The subsoil is brown clay loam about 15 inches thick. The substratum is pale brown loam.

Included with this soil in mapping are small areas of Stoneham sandy loam, 3 to 8 percent slopes; Keith silt loam, 0 to 3 percent slopes; Olney sandy loam, 0 to 3 percent slopes; Bresser sandy loam, 0 to 3 percent slopes; and Wiley silt loam, 1 to 3 percent slopes.

Permeability of this Fort Collins soil is moderate. Effective rooting depth is 60 inches or more. Available water capacity is high. Surface runoff is medium, and the hazard of erosion is moderate.

This soil is used as rangeland and for dryland farming. Wheat and feed grains such as millet are the crops commonly grown. Crop residue management, minimum tillage,

ble water capacity can influence seedling survival. Seedling mortality is severe on the Rizoza soil because of low available water capacity.

These soils are suited to habitat for wildlife such as antelope, mule deer, and wild turkey. The combination of juniper and pinyon on these soils makes them attractive to wild turkey, but a shortage of surface water may limit turkey populations. This limitation can be overcome by constructing watering facilities, such as guzzlers.

The main limitations of the Rizoza soil for construction are shallow depth to bedrock, a stony surface, and steep slopes. The main limitation of the Neville soil is its limited ability to support a load and shrink-swell potential. Buildings and roads must be designed to overcome these limitations. Access roads should have adequate cut-slope grade and be provided with drains to control surface runoff. Capability subclass VIIe.

77—Rock outcrop-Coldcreek-Tolman complex, 9 to 90 percent slopes. This strongly sloping to extremely steep complex is on mountains. The average annual precipitation is about 20 inches, and the average annual air temperature is about 42 degrees F.

Rock outcrop makes up about 30 percent of the complex, the Coldcreek soil about 30 percent, the Tolman soil about 20 percent, and other soils about 20 percent.

Included with this complex in mapping are areas of Kuttler-Broadmoor-Rock outcrop complex, 25 to 90 percent slopes; Fortwingate-Rock outcrop complex, 15 to 60 percent slopes; and Nederland cobbly sandy loam, 9 to 25 percent slopes. Areas of talus occur below some areas of Rock outcrop.

Rock outcrop occurs throughout the complex. It is most commonly on the upper part of the slopes. Runoff is rapid.

The Coldcreek soil is deep and well drained. It formed in mixed, acid igneous material. Typically, the surface layer is dark gray cobbly loam about 6 inches thick. The subsurface layer is light gray extremely cobbly sandy loam that is mixed with a lesser amount of brown clay loam and is about 25 inches thick. The subsoil is brown extremely cobbly clay loam that has coatings of light gray and is about 12 inches thick. Hard fractured bedrock is at a depth of about 43 inches.

Permeability of the Coldcreek soil is moderate. Effective rooting depth is 40 inches or more. Available water capacity is moderate. Surface runoff is medium, and the hazard of erosion is moderate.

The Tolman soil is shallow and well drained. It formed in medium textured residuum derived from acid igneous rock. Typically, the surface layer is dark grayish brown gravelly sandy loam about 4 inches thick. The subsoil is brown very cobbly sandy clay loam about 9 inches thick. Hard igneous bedrock is at a depth of 13 inches.

Permeability of the Tolman soil is moderate. Effective rooting depth is 10 to 20 inches. Available water capacity is low. Surface runoff is medium, and the hazard of erosion is moderate.

The Coldcreek soil is used mainly for woodland, recreation, and wildlife habitat and as a source of gravel. The Tolman soil is used mainly as rangeland and for wildlife habitat.

The Coldcreek soil is suited to the production of Douglas-fir. It is capable of producing about 690 cubic feet, or 1,000 board feet (International rule), of merchantable timber per acre from a fully stocked, even-aged stand of 80-year-old trees. The main limitations for its use for timber production are slope, hazard of erosion, and the presence of stones on the surface. The stones can hinder felling, yarding, and other operations involving the use of equipment. Practices must be used to minimize erosion when harvesting timber.

The Tolman soil is suited to vegetation suitable for grazing and to the production of some firewood. Rangeland vegetation is mainly mountain muhly, big bluestem, little bluestem, side-oats grama, and western wheatgrass. The common shrubs and trees are mountainmahogany, skunkbush sumac, and Rocky Mountain juniper. There are lesser amounts of ponderosa pine.

Proper range management is necessary on the Tolman soil. Properly locating livestock watering facilities helps to control grazing. Deferment of grazing helps to maintain vigor and production of plants.

The Coldcreek soil is suited to habitat suitable for woodland wildlife, especially mule deer, wild turkey, and blue grouse. To encourage wild turkey in areas where there is little or no water, wildlife watering facilities, such as guzzlers, can be developed. Because of the steep slopes, livestock grazing should be discouraged, which would benefit the wildlife that use these areas.

Rangeland wildlife, such as antelope, cottontail, coyote, and scaled quail, is best adapted for life on the Tolman soil. Forage production is typically low, and proper livestock grazing management is necessary if wildlife and livestock share the range. Livestock watering developments are needed, and they are used by various wildlife species.

The main limitations of the soils of this complex for urban use or homesite development are rock outcrops, stones, depth to bedrock, especially on the Tolman soil, and steep slope. Homesites should be located in places where these limitations are the least severe. Special designs for buildings and roads are required to overcome these limitations. Capability subclass VIIe.

78—Sampson loam, 0 to 3 percent slopes. This deep, well drained soil formed in alluvium derived from sedimentary rock on terraces and alluvial fans and in small closed basins. Elevation ranges from about 5,500 to 6,500 feet. The average annual precipitation is about 14 inches, the average annual air temperature is about 48 degrees F, and the average frost-free period is about 145 days.

Typically, the surface layer is dark grayish brown loam about 6 inches thick. The subsoil, about 44 inches thick, is dark brown to brown clay loam that grades to light brownish gray sandy clay loam in the lower part. The substratum is light brownish gray sandy clay loam to a

depth of 60 inches. The lower part of the subsoil and the substratum have visible soft masses of lime.

Included with this soil in mapping are small areas of Bresser sandy loam, 0 to 3 percent slopes; Nunn clay loam, 0 to 3 percent slopes; and Olney sandy loam, 0 to 3 percent slopes. Also included are areas of Vona sandy loam, 1 to 3 percent slopes, and Ustic Torrifluvents, loamy.

Permeability of this Sampson soil is moderate. Effective rooting depth is 60 inches or more. Available water capacity is high. Surface runoff is slow, and the hazard of erosion is slight.

About one-third of the acreage of this soil is used for irrigated corn and alfalfa and for dryfarmed wheat. The slow surface runoff and slight hazard of erosion reduce the need for use of intensive conservation practices. Most of the remaining acreage is used as rangeland.

This soil is well suited to the production of native vegetation suitable for grazing. Native vegetation is mainly blue grama, western wheatgrass, side-oats grama, sand dropseed, and galleta. Needleandthread, big bluestem, and native bluegrasses are also present where this soil occurs in the northern part of the survey area.

Fencing and properly locating livestock watering facilities help to control grazing. Deferment of grazing may be necessary to maintain a needed balance between livestock demands and forage production. In areas where the plant cover has been depleted, pitting can be used to help the native vegetation recover. Chemical control may be needed in disturbed areas where dense stands of pricklypear occur. Ample amounts of litter and forage should be left on the soil because of the high hazard of soil blowing.

Windbreaks and environmental plantings generally are well suited to this soil. Summer fallow a year prior to planting and continued cultivation for weed control are needed to insure the establishment and survival of plantings. Trees that are best suited and have good survival are Rocky Mountain juniper, eastern redcedar, ponderosa pine, Siberian elm, Russian-olive, and hackberry. Shrubs that are best suited are skunkbush sumac, lilac, Siberian peashrub, and American plum.

This soil is best suited to habitat for openland and rangeland wildlife. In cropland areas, habitat favorable for ring-necked pheasant, mourning dove, and many nongame species can be developed by establishing areas for nesting and escape cover. For pheasant, undisturbed nesting cover is vital and should be provided for in plans for habitat development. This is especially true in areas of intensive farming. Rangeland wildlife, such as pronghorn antelope, can be encouraged by developing livestock watering facilities, properly managing livestock grazing, and reseeding range where needed.

The main limitations of this soil for homesites or urban use are limited ability to support a load, the shrink-swell potential of the subsoil, and frost-action potential. Special designs for buildings and roads and streets are necessary to overcome these limitations. Capability subclasses IVe, nonirrigated, and IIe, irrigated.

79—Satanta loam, 0 to 3 percent slopes. This deep, well drained soil formed in loamy eolian material derived from mixed sources on uplands. Elevation ranges from 5,900 to 6,500 feet. The average annual precipitation is about 15 inches, the average annual air temperature is about 47 degrees F, and the average frost-free period is about 145 days.

Typically, the surface layer is brown loam about 4 inches thick. The lower part of the subsoil has visible soft masses of lime. The subsoil is brown clay loam about 35 inches thick. The substratum is pale brown silt loam to a depth of 60 inches or more.

Included with this soil in mapping are small areas of Ascalon sandy loam, 1 to 3 percent slopes; Bresser sandy loam, 0 to 3 percent slopes; and Wiley silt loam, 1 to 3 percent slopes.

Permeability of this Satanta soil is moderate. Effective rooting depth is 60 inches or more. Available water capacity is high. Surface runoff is slow, and the hazard of erosion is slight.

Most areas of this soil in the northeastern part of the survey area are cultivated. Most areas in the southwestern part are used as rangeland, for wildlife habitat, and for military maneuvers.

Wheat, fallow, and feed grains are used in a flexible cropping system because precipitation is insufficient for annual cropping. Minimum tillage and crop residue management usually are adequate to control erosion. This soil is one of the best in the survey area.

This soil is well suited to native vegetation suitable for grazing. The native vegetation is mainly western wheatgrass, needlegrasses, side-oats grama, and blue grama. If the range has deteriorated, blue grama, junegrass, and native bluegrasses increase. Sleepygrass and annuals replace these grasses if the range has seriously deteriorated.

Seeding is a good practice if the range is in poor condition. Seeding of the native vegetation is desirable, but the range can also be seeded with tame species of grass such as Nordan crested wheatgrass, Russian wildrye, pubescent wheatgrass, or intermediate wheatgrass. Use of deferred grazing and other good range management practices helps to maintain vigor and growth of plants. Fencing and properly locating livestock watering facilities help to control grazing.

Windbreaks and environmental plantings generally are well suited to this soil. Summer fallow a year prior to planting and continued cultivation for weed control are needed to insure the establishment and survival of plantings. Trees that are best suited and have good survival are Rocky Mountain juniper, eastern redcedar, ponderosa pine, Siberian elm, Russian-olive, and hackberry. Shrubs that are best suited are skunkbush sumac, lilac, Siberian peashrub, and American plum.

This soil is best suited to habitat for openland and rangeland wildlife. In cropland areas, habitat favorable for ring-necked pheasant, mourning dove, and many nongame species can be developed by establishing areas for nesting

9 Hydrologic Calculations

Runoff Coefficients and Percent Imperviousness Table 6-6

Colorado Springs Rainfall Intensity Duration Frequency Table 6-5

Hydrologic Calculations Summary Form SF-1 for Existing & Developed Conditions

Hydrologic Calculations Summary 5-yr Form SF-2 for Existing & Developed Conditions

Hydrologic Calculations Summary 100-yr Form SF-2 for Existing & Developed Conditions

Table 6-6. Runoff Coefficients for Rational Method
(Source: UDFCD 2001)

Land Use or Surface Characteristics	Percent Impervious	Runoff Coefficients											
		2-year		5-year		10-year		25-year		50-year		100-year	
		HSG A&B	HSG C&D	HSG A&B	HSG C&D	HSG A&B	HSG C&D	HSG A&B	HSG C&D	HSG A&B	HSG C&D	HSG A&B	HSG C&D
Business													
Commercial Areas	95	0.79	0.80	0.81	0.82	0.83	0.84	0.85	0.87	0.87	0.88	0.88	0.89
Neighborhood Areas	70	0.45	0.49	0.49	0.53	0.53	0.57	0.58	0.62	0.60	0.65	0.62	0.68
Residential													
1/8 Acre or less	65	0.41	0.45	0.45	0.49	0.49	0.54	0.54	0.59	0.57	0.62	0.59	0.65
1/4 Acre	40	0.23	0.28	0.30	0.35	0.36	0.42	0.42	0.50	0.46	0.54	0.50	0.58
1/3 Acre	30	0.18	0.22	0.25	0.30	0.32	0.38	0.39	0.47	0.43	0.52	0.47	0.57
1/2 Acre	25	0.15	0.20	0.22	0.28	0.30	0.36	0.37	0.46	0.41	0.51	0.46	0.56
1 Acre	20	0.12	0.17	0.20	0.26	0.27	0.34	0.35	0.44	0.40	0.50	0.44	0.55
Industrial													
Light Areas	80	0.57	0.60	0.59	0.63	0.63	0.66	0.66	0.70	0.68	0.72	0.70	0.74
Heavy Areas	90	0.71	0.73	0.73	0.75	0.75	0.77	0.78	0.80	0.80	0.82	0.81	0.83
Parks and Cemeteries													
Parks and Cemeteries	7	0.05	0.09	0.12	0.19	0.20	0.29	0.30	0.40	0.34	0.46	0.39	0.52
Playgrounds	13	0.07	0.13	0.16	0.23	0.24	0.31	0.32	0.42	0.37	0.48	0.41	0.54
Railroad Yard Areas	40	0.23	0.28	0.30	0.35	0.36	0.42	0.42	0.50	0.46	0.54	0.50	0.58
Undeveloped Areas													
Historic Flow Analysis-- Greenbelts, Agriculture	2	0.03	0.05	0.09	0.16	0.17	0.26	0.26	0.38	0.31	0.45	0.36	0.51
Pasture/Meadow	0	0.02	0.04	0.08	0.15	0.15	0.25	0.25	0.37	0.30	0.44	0.35	0.50
Forest	0	0.02	0.04	0.08	0.15	0.15	0.25	0.25	0.37	0.30	0.44	0.35	0.50
Exposed Rock	100	0.89	0.89	0.90	0.90	0.92	0.92	0.94	0.94	0.95	0.95	0.96	0.96
Offsite Flow Analysis (when landuse is undefined)	45	0.26	0.31	0.32	0.37	0.38	0.44	0.44	0.51	0.48	0.55	0.51	0.59
Streets													
Paved	100	0.89	0.89	0.90	0.90	0.92	0.92	0.94	0.94	0.95	0.95	0.96	0.96
Gravel	80	0.57	0.60	0.59	0.63	0.63	0.66	0.66	0.70	0.68	0.72	0.70	0.74
Drive and Walks													
Drive and Walks	100	0.89	0.89	0.90	0.90	0.92	0.92	0.94	0.94	0.95	0.95	0.96	0.96
Roofs													
Roofs	90	0.71	0.73	0.73	0.75	0.75	0.77	0.78	0.80	0.80	0.82	0.81	0.83
Lawns													
Lawns	0	0.02	0.04	0.08	0.15	0.15	0.25	0.25	0.37	0.30	0.44	0.35	0.50

Figure 6-5. Colorado Springs Rainfall Intensity Duration Frequency

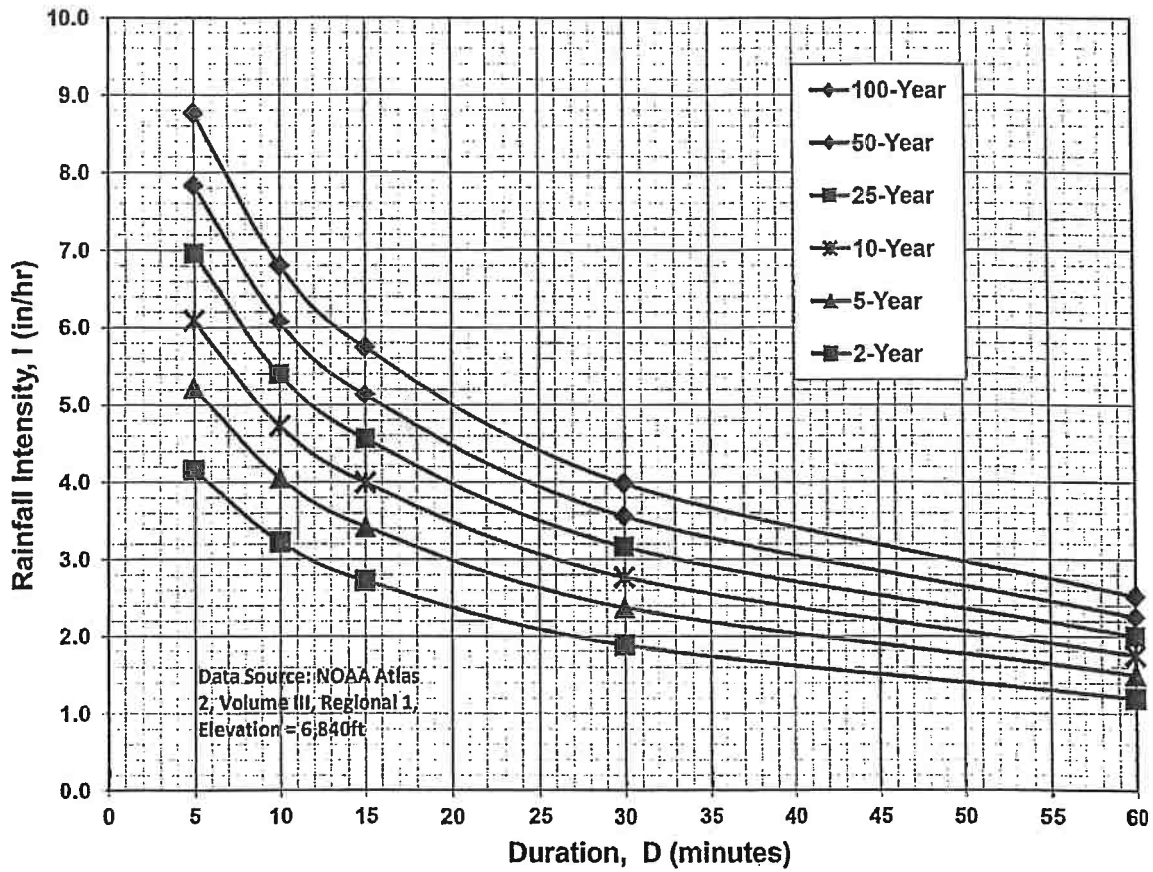

IDF Equations

$$I_{100} = -2.52 \ln(D) + 12.735$$

$$I_{50} = -2.25 \ln(D) + 11.375$$

$$I_{25} = -2.00 \ln(D) + 10.111$$

$$I_{10} = -1.75 \ln(D) + 8.847$$

$$I_5 = -1.50 \ln(D) + 7.583$$

$$I_2 = -1.19 \ln(D) + 6.035$$

Note: Values calculated by equations may not precisely duplicate values read from figure.

Job No.: 61182
 Project: RMCC

Date: 2/27/2024 11:21
 Calcs By: TJW
 Checked By: _____

Time of Concentration (Modified from Standard Form SF-1)

Sub-Basin	Sub-Basin Data				Overland			Shallow Channel				Channelized				t _c Check		t _c (min)
	Area (Acres)	C ₅	C ₁₀₀ /CN	% Imp.	L ₀ (ft)	S ₀ (%)	t _i (min)	L _{0t} (ft)	S _{0t} (ft/ft)	v _{0sc} (ft/s)	t _t (min)	L _{0c} (ft)	S _{0c} (ft/ft)	v _{0c} (ft/s)	t _c (min)	L (min)	t _{c,alt} (min)	
EX-A1	2.64	0.21	0.44	20%	300	1%	27.8	280	0.007	0.6	7.9	0	0.000	0.0	0.0	580	N/A	35.7
A1	0.34	0.49	0.65	50%	28	7%	3.1	0	0.000	0.0	0.0	309	0.010	2.0	2.6	337	N/A	5.7
A2	0.18	0.08	0.35	0%	64	2%	12.0	0	0.000	0.0	0.0	0	0.000	0.0	0.0	64	N/A	12.0
A3	1.17	0.55	0.69	59%	156	1%	12.7	92	0.016	0.9	1.7	0	0.000	0.0	0.0	248	N/A	14.4
A4	0.95	0.20	0.43	15%	270	1%	23.6	0	0.000	0.0	0.0	0	0.000	0.0	0.0	270	N/A	23.6

Job No.: **61182**
 Project: **RMCC**
 Design Storm: **100-Year Storm (1% Probability)**
 Jurisdiction: **DCM**

Date: **2/27/2024 11:21**
 Calcs By: **TJW**
 Checked By: _____

Sub-Basin and Combined Flows (Modified from Standard Form SF-2)

DP	Sub-Basin	Area (Acres)	C100	Direct Runoff				Combined Runoff				Streetflow			Pipe Flow				Travel Time			
				t _c (min)	CA (Acres)	I100 (in/hr)	Q100 (cfs)	t _c (min)	CA (Acres)	I100 (in/hr)	Q100 (cfs)	Slope (%)	Length (ft)	Q (cfs)	Q (cfs)	Slope (%)	Mnngs n	Length (ft)	D _{Pipe} (in)	Length (ft)	V _{Disc} (ft/s)	t _t (min)
EX-DP1	EX-A1	2.64	0.44	35.7	1.17	3.73	4.35															
DP1	A1	0.34	0.65	5.7	0.22	8.35	1.86															
	A2	0.18	0.35	12.0	0.06	6.48	0.40															
DP2	A3	1.17	0.69	14.4	0.81	6.02	4.86															
	A4	0.95	0.43	23.6	0.41	4.77	1.98															
DP3		1.47	0.47					23.6	0.70	4.77	3.3											

DCM: $I = C1 * \ln(tc) + C2$
 C1: 2.52
 C1: 12.735

Sub-Basin Ex-A1 Runoff Calculations (EX DP1)

Job No.: **61182**

Date: **2/27/2024 11:21**

Project: **RMCC**

Calcs by: **TJW**

Jurisdiction: **DCM**
Runoff Coefficient: **Surface Type**

Checked by: _____
Soil Type: **B**
Urbanization: **Non-Urban**

Basin Land Use Characteristics

Surface	Area		Runoff Coefficient						% Imperv.
	(SF)	(Acres)	C2	C5	C10	C25	C50	C100	
Pasture/Meadow	87,714	2.01	0.02	0.08	0.15	0.25	0.3	0.35	0%
Gravel	21,106	0.48	0.57	0.59	0.63	0.66	0.68	0.7	80%
Roofs	3,733	0.09	0.71	0.73	0.75	0.78	0.8	0.81	90%
Paved	2,437	0.06	0.89	0.9	0.92	0.94	0.95	0.96	100%
Combined	114,990	2.64	0.16	0.21	0.27	0.36	0.40	0.44	19.7%

114990

Basin Travel Time

	Shallow Channel Ground Cover		Short Pasture/Lawns			
	$L_{max,Overland}$				C_v	
	L (ft)	ΔZ_0 (ft)	S_0 (ft/ft)	v (ft/s)	t (min)	t_{Alt} (min)
Total	580	5	-	-	-	-
Initial Time	300	3	0.010	-	27.8	N/A DCM Eq. 6-8
Shallow Channel	280	2	0.007	0.6	7.9	- DCM Eq. 6-9
Channelized			0.000	0.0	0.0	- V-Ditch
				t_c	35.7 min.	

Rainfall Intensity & Runoff

	2-Yr	5-Yr	10-Yr	25-Yr	50-Yr	100-Yr
Intensity (in/hr)	1.78	2.22	2.59	2.96	3.33	3.73
Runoff (cfs)	0.8	1.2	1.9	2.8	3.5	4.4
Release Rates (cfs/ac)	-	-	-	-	-	-
Allowed Release (cfs)	0.8	1.2	1.9	2.8	3.5	4.4

DCM: $I = C1 * \ln(tc) + C2$

C1 1.19 1.5 1.75 2 2.25 2.52

C2 6.035 7.583 8.847 10.111 11.375 12.735

Notes

Sub-Basin A1 Runoff Calculations (DP1)

Job No.: **61182**

Date: **2/27/2024 11:21**

Project: **RMCC**

Calcs by: **TJW**

Jurisdiction: **DCM**
Runoff Coefficient: **Surface Type**

Checked by: _____
Soil Type: **B**
Urbanization: **Non-Urban**

Basin Land Use Characteristics

Surface	Area		Runoff Coefficient						% Imperv.
	(SF)	(Acres)	C2	C5	C10	C25	C50	C100	
Pasture/Meadow	7,480	0.17	0.02	0.08	0.15	0.25	0.3	0.35	0%
Gravel			0.57	0.59	0.63	0.66	0.68	0.7	80%
Roofs			0.71	0.73	0.75	0.78	0.8	0.81	90%
Paved	7,380	0.17	0.89	0.9	0.92	0.94	0.95	0.96	100%
Combined	14,860	0.34	0.45	0.49	0.53	0.59	0.62	0.65	49.7%

19860

Basin Travel Time

	Shallow Channel Ground Cover		Short Pasture/Lawns			
	$L_{max,Overland}$		S_0	v	t	t_{Alt}
	L (ft)	ΔZ_0 (ft)	(ft/ft)	(ft/s)	(min)	(min)
Total	337	5	-	-	-	-
Initial Time	28	2	0.071	-	3.1	N/A DCM Eq. 6-8
Shallow Channel			0.000	0.0	0.0	- DCM Eq. 6-9
Channelized	309	3	0.010	2.0	2.6	- V-Ditch
				t_c	5.7 min.	

Rainfall Intensity & Runoff

	2-Yr	5-Yr	10-Yr	25-Yr	50-Yr	100-Yr
Intensity (in/hr)	3.97	4.98	5.80	6.63	7.46	8.35
Runoff (cfs)	0.6	0.8	1.1	1.3	1.6	1.9
Release Rates (cfs/ac)	-	-	-	-	-	-
Allowed Release (cfs)	0.6	0.8	1.1	1.3	1.6	1.9

DCM: $I = C1 * \ln(tc) + C2$

C1 1.19 1.5 1.75 2 2.25 2.52
C2 6.035 7.583 8.847 10.111 11.375 12.735

Notes

Sub-Basin A2 Runoff Calculations

Job No.: **61182**
 Project: **RMCC**
 Jurisdiction: **DCM**
 Runoff Coefficient: **Surface Type**

Date: **2/27/2024 11:21**
 Calcs by: **TJW**
 Checked by: _____
 Soil Type: **B**
 Urbanization: **Non-Urban**

Basin Land Use Characteristics

Surface	Area		Runoff Coefficient						% Imperv.
	(SF)	(Acres)	C2	C5	C10	C25	C50	C100	
Pasture/Meadow	7,672	0.18	0.02	0.08	0.15	0.25	0.3	0.35	0%
Gravel			0.57	0.59	0.63	0.66	0.68	0.7	80%
Roofs			0.71	0.73	0.75	0.78	0.8	0.81	90%
Paved			0.89	0.9	0.92	0.94	0.95	0.96	100%
Combined	7,672	0.18	0.02	0.08	0.15	0.25	0.30	0.35	0.0%

Basin Travel Time

	L (ft)	ΔZ_0 (ft)	S_0 (ft/ft)	v (ft/s)	t (min)	t_{Alt} (min)
Shallow Channel	64	1	-	-	-	-
Ground Cover						
Short Pasture/Lawns						
$L_{max,Overland}$	300 ft					
C_v					7	
Total	64	1	-	-	-	-
Initial Time	64	1	0.019	-	12.0	N/A DCM Eq. 6-8
Shallow Channel			0.000	0.0	0.0	- DCM Eq. 6-9
Channelized			0.000	0.0	0.0	- V-Ditch
				t_c	12.0 min.	

Rainfall Intensity & Runoff

	2-Yr	5-Yr	10-Yr	25-Yr	50-Yr	100-Yr
Intensity (in/hr)	3.08	3.86	4.50	5.15	5.79	6.48
Runoff (cfs)	0.0	0.1	0.1	0.2	0.3	0.4
Release Rates (cfs/ac)	-	-	-	-	-	-
Allowed Release (cfs)	0.0	0.1	0.1	0.2	0.3	0.4

DCM: $I = C1 * \ln(tc) + C2$

C1	1.19	1.5	1.75	2	2.25	2.52
C2	6.035	7.583	8.847	10.111	11.375	12.735

Notes

Sub-Basin A3 Runoff Calculations (DP2)

Job No.: 61182
 Project: RMCC
 Jurisdiction: DCM
 Runoff Coefficient: Surface Type

Date: 2/27/2024 11:21
 Calcs by: TJW
 Checked by: _____
 Soil Type: B
 Urbanization: Non-Urban

Basin Land Use Characteristics

Surface	Area		Runoff Coefficient						% Imperv.
	(SF)	(Acres)	C2	C5	C10	C25	C50	C100	
Pasture/Meadow	19,908	0.46	0.02	0.08	0.15	0.25	0.3	0.35	0%
Gravel			0.57	0.59	0.63	0.66	0.68	0.7	80%
Roofs	10,000	0.23	0.71	0.73	0.75	0.78	0.8	0.81	90%
Paved	20,962	0.48	0.89	0.9	0.92	0.94	0.95	0.96	100%
Combined	50,870	1.17	0.51	0.55	0.59	0.64	0.67	0.69	58.9%

45870

Basin Travel Time

	Shallow Channel Ground Cover		Short Pasture/Lawns			
	$L_{max,Overland}$	ΔZ_0 (ft)	S_0 (ft/ft)	v (ft/s)	t (min)	t_{Alt} (min)
	300 ft	3	-	-	-	-
Total	248	3	-	-	-	-
Initial Time	156	2	0.010	-	12.7	N/A DCM Eq. 6-8
Shallow Channel	92	2	0.016	0.9	1.7	- DCM Eq. 6-9
Channelized			0.000	0.0	0.0	- V-Ditch
				t_c	14.4 min.	

Rainfall Intensity & Runoff

	2-Yr	5-Yr	10-Yr	25-Yr	50-Yr	100-Yr
Intensity (in/hr)	2.86	3.58	4.18	4.78	5.38	6.02
Runoff (cfs)	1.7	2.3	2.9	3.6	4.2	4.9
Release Rates (cfs/ac)	-	-	-	-	-	-
Allowed Release (cfs)	1.7	2.3	2.9	3.6	4.2	4.9

DCM: $I = C1 * \ln(tc) + C2$

C1 1.19 1.5 1.75 2 2.25 2.52
 C2 6.035 7.583 8.847 10.111 11.375 12.735

Notes

Sub-Basin A3 Runoff Calculations

Job No.: **61182**

Date: **2/27/2024 11:21**

Project: **RMCC**

Calcs by: **TJW**

Jurisdiction: **DCM**
Runoff Coefficient: **Surface Type**

Checked by: _____
Soil Type: **B**
Urbanization: **Non-Urban**

Basin Land Use Characteristics

Surface	Area		Runoff Coefficient						% Imperv.
	(SF)	(Acres)	C2	C5	C10	C25	C50	C100	
Pasture/Meadow	34,906	0.80	0.02	0.08	0.15	0.25	0.3	0.35	0%
Gravel			0.57	0.59	0.63	0.66	0.68	0.7	80%
Roofs	3,733	0.09	0.71	0.73	0.75	0.78	0.8	0.81	90%
Paved	2,928	0.07	0.89	0.9	0.92	0.94	0.95	0.96	100%
Combined	41,567	0.95	0.14	0.20	0.26	0.35	0.39	0.43	15.1%

41587

Basin Travel Time

	Shallow Channel	Ground Cover	Short Pasture/Lawns
	$L_{max,Overland}$	300 ft	C_v 7
	L (ft)	ΔZ_0 (ft)	S_0 (ft/ft) v (ft/s) t (min) t_{Alt} (min)
Total	270	4	- - - -
Initial Time	270	4	0.015 - 23.6 N/A DCM Eq. 6-8
Shallow Channel			0.000 0.0 0.0 - DCM Eq. 6-9
Channelized			0.000 0.0 0.0 - V-Ditch
			t_c 23.6 min.

Rainfall Intensity & Runoff

	2-Yr	5-Yr	10-Yr	25-Yr	50-Yr	100-Yr
Intensity (in/hr)	2.28	2.84	3.32	3.79	4.27	4.77
Runoff (cfs)	0.3	0.5	0.8	1.3	1.6	2.0
Release Rates (cfs/ac)	-	-	-	-	-	-
Allowed Release (cfs)	0.3	0.5	0.8	1.3	1.6	2.0

DCM: $I = C1 * \ln(tc) + C2$

C1 1.19 1.5 1.75 2 2.25 2.52

C2 6.035 7.583 8.847 10.111 11.375 12.735

Notes

Combined Sub-Basin Runoff Calculations

Includes Basins A1 A2 A4

Job No.: **61182**

Date: **2/27/2024 11:21**

Project: **RMCC**

Calcs by: **TJW**

Jurisdiction: **DCM**
Runoff Coefficient: **Surface Type**

Checked by: _____
Soil Type: **B**
Urbanization: **Non-Urban**

Basin Land Use Characteristics

Surface	Area		Runoff Coefficient						% Imperv.
	(SF)	(Acres)	C2	C5	C10	C25	C50	C100	
Pasture/Meadow	50,058	1.15	0.02	0.08	0.15	0.25	0.3	0.35	0%
Gravel	-	0.00	0.57	0.59	0.63	0.66	0.68	0.7	80%
Roofs	3,733	0.09	0.71	0.73	0.75	0.78	0.8	0.81	90%
Paved	10,308	0.24	0.89	0.9	0.92	0.94	0.95	0.96	100%
Combined	64,099	1.47	0.20	0.25	0.31	0.39	0.43	0.47	21.3%

Basin Travel Time

	Sub-basin or Channel Type	Material Type	L (ft)	Elev. ΔZ_0 (ft)	Q_i (cfs)	Base or Dia (ft)	Sides z:1 (ft/ft)	v (ft/s)	t (min)
Furthest Reach	A4	-	270	4	-	-	-	-	23.6
Channelized-1					2		10		
Channelized-2									
Channelized-3									
Total			270	4					
								t_c (min)	23.6

Contributing Offsite Flows (Added to Runoff and Allowed Release, below.)

Contributing Basins/Areas	Pond Outflow (DP2 Out)
Q_{Minor}	0 (cfs) - 5-year Storm
Q_{Major}	0.6 (cfs) - 100-year Storm

Rainfall Intensity & Runoff

	2-Yr	5-Yr	10-Yr	25-Yr	50-Yr	100-Yr
Intensity (in/hr)	2.28	2.84	3.32	3.79	4.27	4.77
Site Runoff (cfs)	0.67	1.05	1.51	2.19	2.72	3.34
OffSite Runoff (cfs)	-	0.00	-	-	-	0.60
Release Rates (cfs/ac)	-	-	-	-	-	-
Allowed Release (cfs)	-	1.0	-	-	-	3.9

DCM: $I = C1 * \ln(tc) + C2$

C1	1.19	1.5	1.75	2	2.25	2.52
C2	6.035	7.583	8.847	10.111	11.375	12.735

Notes

Runoff from Offsite basins have been assumed constant, despite additional times of concentration.

10 Hydraulic Calculations

Extended Detention Basin Design Worksheet – UD-BMP Version 3.07

Extended Detention Basin Design Calculations – MHFD-Detention Version 4.02

Emergency Spillway Protection Design Calculations

Pond Outfall Pipe Rip Rap Calculations

Design Procedure Form: Extended Detention Basin (EDB)

UD-BMP (Version 3.07, March 2018)

Sheet 1 of 3

Designer: TJW
Company: MVE, Inc.
Date: April 8, 2025
Project: RMCC
Location: Pond A3

<p>1. Basin Storage Volume</p> <p>A) Effective Imperviousness of Tributary Area, I_a</p> <p>B) Tributary Area's Imperviousness Ratio ($i = I_a / 100$)</p> <p>C) Contributing Watershed Area</p> <p>D) For Watersheds Outside of the Denver Region, Depth of Average Runoff Producing Storm</p> <p>E) Design Concept (Select EURV when also designing for flood control)</p> <p>F) Design Volume (WQCV) Based on 40-hour Drain Time ($V_{DESIGN} = (1.0 * (0.91 * i^3 - 1.19 * i^2 + 0.78 * i) / 12 * Area)$)</p> <p>G) For Watersheds Outside of the Denver Region, Water Quality Capture Volume (WQCV) Design Volume ($V_{WQCV\ OTHER} = (d_6 * (V_{DESIGN} / 0.43))$)</p> <p>H) User Input of Water Quality Capture Volume (WQCV) Design Volume (Only if a different WQCV Design Volume is desired)</p> <p>I) NRCS Hydrologic Soil Groups of Tributary Watershed i) Percentage of Watershed consisting of Type A Soils ii) Percentage of Watershed consisting of Type B Soils iii) Percentage of Watershed consisting of Type C/D Soils</p> <p>J) Excess Urban Runoff Volume (EURV) Design Volume For HSG A: $EURV_A = 1.68 * i^{1.28}$ For HSG B: $EURV_B = 1.36 * i^{1.08}$ For HSG C/D: $EURV_{C/D} = 1.20 * i^{1.08}$</p> <p>K) User Input of Excess Urban Runoff Volume (EURV) Design Volume (Only if a different EURV Design Volume is desired)</p>	<p>$I_a =$ <input type="text" value="58.9"/> %</p> <p>$i =$ <input type="text" value="0.589"/></p> <p>Area = <input type="text" value="1.170"/> ac</p> <p>$d_6 =$ <input type="text" value="0.42"/> in</p> <div style="border: 1px solid black; padding: 5px; margin: 5px 0;"> <p>Choose One</p> <p><input type="radio"/> Water Quality Capture Volume (WQCV)</p> <p><input checked="" type="radio"/> Excess Urban Runoff Volume (EURV)</p> </div> <p>$V_{DESIGN} =$ <input type="text"/> ac-ft</p> <p>$V_{DESIGN\ OTHER} =$ <input type="text" value="0.022"/> ac-ft</p> <p>$V_{DESIGN\ USER} =$ <input type="text"/> ac-ft</p> <p>$HSG_A =$ <input type="text" value="100"/> % $HSG_B =$ <input type="text" value="0"/> % $HSG_{C/D} =$ <input type="text" value="0"/> %</p> <p>$EURV_{DESIGN} =$ <input type="text" value="0.083"/> ac-ft</p> <p>$EURV_{DESIGN\ USER} =$ <input type="text"/> ac-ft</p>
<p>2. Basin Shape: Length to Width Ratio (A basin length to width ratio of at least 2:1 will improve TSS reduction.)</p>	<p>L : W = <input type="text" value="2.0"/> : 1</p>
<p>3. Basin Side Slopes</p> <p>A) Basin Maximum Side Slopes (Horizontal distance per unit vertical, 4:1 or flatter preferred)</p>	<p>Z = <input type="text" value="3.00"/> ft / ft</p> <p align="center">DIFFICULT TO MAINTAIN, INCREASE WHERE POSSIBLE</p>
<p>4. Inlet</p> <p>A) Describe means of providing energy dissipation at concentrated inflow locations:</p>	<p>Flows enter the pond via sheet flow or a shallow swale. No concentrated inflows.</p> <hr/> <hr/> <hr/>
<p>5. Forebay</p> <p>A) Minimum Forebay Volume ($V_{MIN} =$ <input type="text" value="0"/> % of the WQCV)</p> <p>B) Actual Forebay Volume</p> <p>C) Forebay Depth ($D_F =$ <input type="text" value="12"/> inch maximum)</p> <p>D) Forebay Discharge i) Undetained 100-year Peak Discharge ii) Forebay Discharge Design Flow ($Q_F = 0.02 * Q_{100}$)</p> <p>E) Forebay Discharge Design</p> <p>F) Discharge Pipe Size (minimum 8-inches)</p> <p>G) Rectangular Notch Width</p>	<p>$V_{FMIN} =$ <input type="text" value="0.000"/> ac-ft A FOREBAY MAY NOT BE NECESSARY FOR THIS SIZE SITE</p> <p>$V_F =$ <input type="text" value="0.000"/> ac-ft</p> <p>$D_F =$ <input type="text" value="0.0"/> in</p> <p>$Q_{100} =$ <input type="text" value="1.10"/> cfs</p> <p>$Q_F =$ <input type="text" value="0.02"/> cfs</p> <div style="border: 1px solid black; padding: 5px; margin: 5px 0;"> <p>Choose One</p> <p><input type="radio"/> Berm With Pipe</p> <p><input type="radio"/> Wall with Rect. Notch</p> <p><input type="radio"/> Wall with V-Notch Weir</p> </div> <p align="right">Flow too small for berm w/ pipe</p> <p>Calculated $D_P =$ <input type="text"/> in</p> <p>Calculated $W_N =$ <input type="text"/> in</p>

Design Procedure Form: Extended Detention Basin (EDB)

Designer: TJW
Company: MVE, Inc.
Date: April 8, 2025
Project: RMCC
Location: Pond A3

<p>6. Trickle Channel</p> <p>A) Type of Trickle Channel</p> <p>F) Slope of Trickle Channel</p>	<div style="border: 1px solid black; padding: 5px; margin-bottom: 10px;"> Choose One <input type="radio"/> Concrete <input type="radio"/> Soft Bottom </div> <p>S = <input style="width: 50px;" type="text" value=""/> ft / ft</p>
<p>7. Micropool and Outlet Structure</p> <p>A) Depth of Micropool (2.5-feet minimum)</p> <p>B) Surface Area of Micropool (10 ft² minimum)</p> <p>C) Outlet Type</p> <p>D) Smallest Dimension of Orifice Opening Based on Hydrograph Routing (Use UD-Detention)</p> <p>E) Total Outlet Area</p>	<p>D_M = <input style="width: 50px;" type="text" value="2.5"/> ft</p> <p>A_M = <input style="width: 50px;" type="text" value="10"/> sq ft</p> <div style="border: 1px solid black; padding: 5px; margin-bottom: 10px;"> Choose One <input checked="" type="radio"/> Orifice Plate <input type="radio"/> Other (Describe): <hr/><hr/> </div> <p>D_{orifice} = <input style="width: 50px;" type="text" value="0.15"/> inches</p> <p>A_{ot} = <input style="width: 50px;" type="text" value="2.75"/> square inches</p>
<p>8. Initial Surcharge Volume</p> <p>A) Depth of Initial Surcharge Volume (Minimum recommended depth is 4 inches)</p> <p>B) Minimum Initial Surcharge Volume (Minimum volume of 0.3% of the WQCV)</p> <p>C) Initial Surcharge Provided Above Micropool</p>	<p>D_{IS} = <input style="width: 50px;" type="text" value="4"/> in</p> <p>V_{IS} = <input style="width: 50px;" type="text" value=""/> cu ft</p> <p>V_s = <input style="width: 50px;" type="text" value="3.3"/> cu ft</p>
<p>9. Trash Rack</p> <p>A) Water Quality Screen Open Area: $A_t = A_{ot} * 38.5 * (e^{-0.095D})$</p> <p>B) Type of Screen (If specifying an alternative to the materials recommended in the USDCM, indicate "other" and enter the ratio of the total open area to the total screen area for the material specified.)</p> <p style="margin-left: 40px;">Other (Y/N): <input style="width: 50px;" type="text" value="N"/></p> <p>C) Ratio of Total Open Area to Total Area (only for type 'Other')</p> <p>D) Total Water Quality Screen Area (based on screen type)</p> <p>E) Depth of Design Volume (EURV or WQCV) (Based on design concept chosen under 1E)</p> <p>F) Height of Water Quality Screen (H_{TR})</p> <p>G) Width of Water Quality Screen Opening (W_{opening}) (Minimum of 12 inches is recommended)</p>	<p>A_t = <input style="width: 50px;" type="text" value="104"/> square inches</p> <div style="border: 1px solid black; padding: 2px; margin-bottom: 10px; width: fit-content;"> S.S. Well Screen with 60% Open Area </div> <hr/> <hr/> <p>User Ratio = <input style="width: 50px;" type="text" value=""/></p> <p>A_{total} = <input style="width: 50px;" type="text" value="174"/> sq. in.</p> <p>H = <input style="width: 50px;" type="text" value="1.67"/> feet</p> <p>H_{TR} = <input style="width: 50px;" type="text" value="48.04"/> inches</p> <p>W_{opening} = <input style="width: 50px;" type="text" value="12.0"/> inches VALUE LESS THAN RECOMMENDED MIN. WIDTH. WIDTH HAS BEEN SET TO 12 INCHES.</p>

Design Procedure Form: Extended Detention Basin (EDB)

Designer: TJW
Company: MVE, Inc.
Date: April 8, 2025
Project: RMCC
Location: Pond A3

<p>10. Overflow Embankment</p> <p>A) Describe embankment protection for 100-year and greater overtopping:</p> <p>B) Slope of Overflow Embankment (Horizontal distance per unit vertical, 4:1 or flatter preferred)</p>	<div style="border: 1px solid orange; padding: 2px; display: inline-block; margin-bottom: 10px;"> no concrete weir shown on plans, sorry I missed this with the last review. </div> <p>Concrete weir with riprap protection.</p> <hr/> <hr/> <p>Ze = 3.00 ft / ft DIFFICULT TO MAINTAIN, INCREASE WHERE POSSIBLE</p>
<p>11. Vegetation</p>	<div style="border: 1px solid black; padding: 5px; width: fit-content;"> Choose One <input type="radio"/> Irrigated <input checked="" type="radio"/> Not Irrigated </div>
<p>12. Access</p> <p>A) Describe Sediment Removal Procedures</p>	<p>Pond has access from the parking lot with no steep side slope. Gravel maintenance access path provided from parking lot to outlet structure.</p> <hr/> <hr/> <hr/> <hr/>
<p>Notes: _____</p> <hr/> <hr/> <hr/>	

DETENTION BASIN OUTLET STRUCTURE DESIGN

MHFD-Detention, Version 4.02 (February 2020)

Project: RMCC
Basin ID: Pond A3

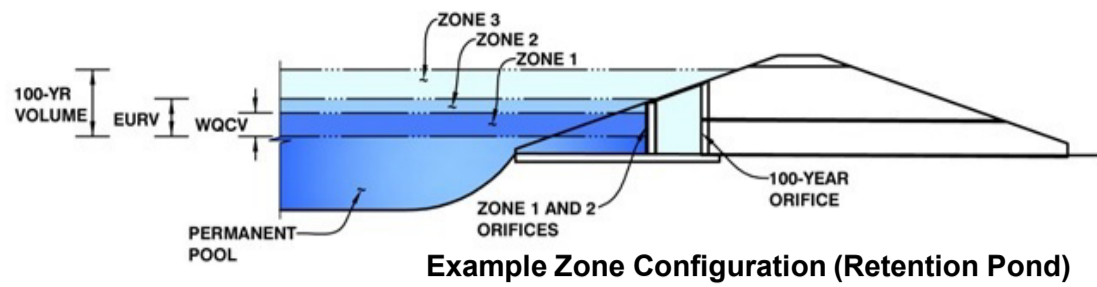

Example Zone Configuration (Retention Pond)

	Estimated Stage (ft)	Estimated Volume (ac-ft)	Outlet Type
Zone 1 (WQCV)	1.12	0.023	Orifice Plate
Zone 2 (EURV)	1.67	0.061	Orifice Plate
Zone 3 (100-year)	1.92	0.044	Weir&Pipe (Restrict)
Total (all zones)		0.127	

User Input: Orifice at Underdrain Outlet (typically used to drain WQCV in a Filtration BMP)

Underdrain Orifice Invert Depth = ft (distance below the filtration media surface)
Underdrain Orifice Diameter = inches

Calculated Parameters for Underdrain

Underdrain Orifice Area = ft²
Underdrain Orifice Centroid = feet

User Input: Orifice Plate with one or more orifices or Elliptical Slot Weir (typically used to drain WQCV and/or EURV in a sedimentation BMP)

Invert of Lowest Orifice = ft (relative to basin bottom at Stage = 0 ft)
Depth at top of Zone using Orifice Plate = ft (relative to basin bottom at Stage = 0 ft)
Orifice Plate: Orifice Vertical Spacing = inches
Orifice Plate: Orifice Area per Row = inches

Calculated Parameters for Plate

WQ Orifice Area per Row = ft²
Elliptical Half-Width = feet
Elliptical Slot Centroid = feet
Elliptical Slot Area = ft²

User Input: Stage and Total Area of Each Orifice Row (numbered from lowest to highest)

	Row 1 (required)	Row 2 (optional)	Row 3 (optional)	Row 4 (optional)	Row 5 (optional)	Row 6 (optional)	Row 7 (optional)	Row 8 (optional)
Stage of Orifice Centroid (ft)	0.00	0.66	1.33	0.00	0.00	0.00	0.00	0.00
Orifice Area (sq. inches)	0.15	0.20	2.40					

	Row 9 (optional)	Row 10 (optional)	Row 11 (optional)	Row 12 (optional)	Row 13 (optional)	Row 14 (optional)	Row 15 (optional)	Row 16 (optional)
Stage of Orifice Centroid (ft)	0.00	0.00	0.00	0.00	0.00	0.00	0.00	0.00
Orifice Area (sq. inches)								

User Input: Vertical Orifice (Circular or Rectangular)

Invert of Vertical Orifice = ft (relative to basin bottom at Stage = 0 ft)
Depth at top of Zone using Vertical Orifice = ft (relative to basin bottom at Stage = 0 ft)
Vertical Orifice Diameter = inches

Calculated Parameters for Vertical Orifice

Vertical Orifice Area = ft²
Vertical Orifice Centroid = feet

User Input: Overflow Weir (Dropbox with Flat or Sloped Grate and Outlet Pipe OR Rectangular/Trapezoidal Weir (and No Outlet Pipe))

	Zone 3 Weir	Not Selected
Overflow Weir Front Edge Height, H _o =	1.75	N/A
Overflow Weir Front Edge Length =	2.92	N/A
Overflow Weir Grate Slope =	0.00	N/A
Horiz. Length of Weir Sides =	3.50	N/A
Overflow Grate Open Area % =	82%	N/A
Debris Clogging % =	50%	N/A

Calculated Parameters for Overflow Weir

	Zone 3 Weir	Not Selected
Height of Grate Upper Edge, H _t =	1.75	N/A
Overflow Weir Slope Length =	3.50	N/A
Grate Open Area / 100-yr Orifice Area =	89.92	N/A
Overflow Grate Open Area w/o Debris =	8.38	N/A
Overflow Grate Open Area w/ Debris =	4.19	N/A

User Input: Outlet Pipe w/ Flow Restriction Plate (Circular Orifice, Restrictor Plate, or Rectangular Orifice)

	Zone 3 Restrictor	Not Selected
Depth to Invert of Outlet Pipe =	0.26	N/A
Outlet Pipe Diameter =	8.00	N/A
Restrictor Plate Height Above Pipe Invert =	2.50	

Calculated Parameters for Outlet Pipe w/ Flow Restriction Plate

	Zone 3 Restrictor	Not Selected
Outlet Orifice Area =	0.09	N/A
Outlet Orifice Centroid =	0.12	N/A
Half-Central Angle of Restrictor Plate on Pipe =	1.19	N/A

User Input: Emergency Spillway (Rectangular or Trapezoidal)

Spillway Invert Stage = ft (relative to basin bottom at Stage = 0 ft)
Spillway Crest Length = feet
Spillway End Slopes = H:V
Freeboard above Max Water Surface = feet

Calculated Parameters for Spillway

Spillway Design Flow Depth = feet
Stage at Top of Freeboard = feet
Basin Area at Top of Freeboard = acres
Basin Volume at Top of Freeboard = acre-ft

Routed Hydrograph Results

The user can override the default CUHP hydrographs and runoff volumes by entering new values in the Inflow Hydrographs table (Columns W through AF).

	WQCV	EURV	2 Year	5 Year	10 Year	25 Year	50 Year	100 Year	500 Year
Design Storm Return Period =									
One-Hour Rainfall Depth (in) =	N/A	N/A	1.19	1.50	1.75	2.00	2.25	2.52	3.25
CUHP Runoff Volume (acre-ft) =	0.023	0.083	0.058	0.077	0.092	0.113	0.133	0.158	0.223
Inflow Hydrograph Volume (acre-ft) =	N/A	N/A	0.058	0.077	0.092	0.113	0.133	0.158	0.223
CUHP Predevelopment Peak Q (cfs) =	N/A	N/A	0.0	0.0	0.0	0.2	0.4	0.7	1.4
OPTIONAL Override Predevelopment Peak Q (cfs) =	N/A	N/A							
Predevelopment Unit Peak Flow, q (cfs/acre) =	N/A	N/A	0.01	0.02	0.02	0.19	0.38	0.62	1.20
Peak Inflow Q (cfs) =	N/A	N/A	0.9	1.2	1.5	1.9	2.3	2.8	4.0
Peak Outflow Q (cfs) =	0.0	0.1	0.0	0.1	0.1	0.2	0.4	0.6	0.9
Ratio Peak Outflow to Predevelopment Q =	N/A	N/A	N/A	3.0	2.4	0.8	1.0	0.9	0.7
Structure Controlling Flow =	Plate	Plate	Plate	Plate	Plate	Overflow Weir 1	Overflow Weir 1	Outlet Plate 1	Spillway
Max Velocity through Grate 1 (fps) =	N/A	N/A	N/A	N/A	N/A	0.0	0.0	0.1	0.1
Max Velocity through Grate 2 (fps) =	N/A	N/A	N/A	N/A	N/A	N/A	N/A	N/A	N/A
Time to Drain 97% of Inflow Volume (hours) =	40	66	64	67	68	69	67	65	62
Time to Drain 99% of Inflow Volume (hours) =	42	72	69	72	74	76	76	75	73
Maximum Ponding Depth (ft) =	1.12	1.67	1.45	1.58	1.67	1.77	1.80	1.86	2.07
Area at Maximum Ponding Depth (acres) =	0.07	0.15	0.12	0.14	0.15	0.17	0.18	0.19	0.24
Maximum Volume Stored (acre-ft) =	0.023	0.083	0.054	0.070	0.083	0.100	0.103	0.116	0.159

Figure 13-12c. Emergency Spillway Protection

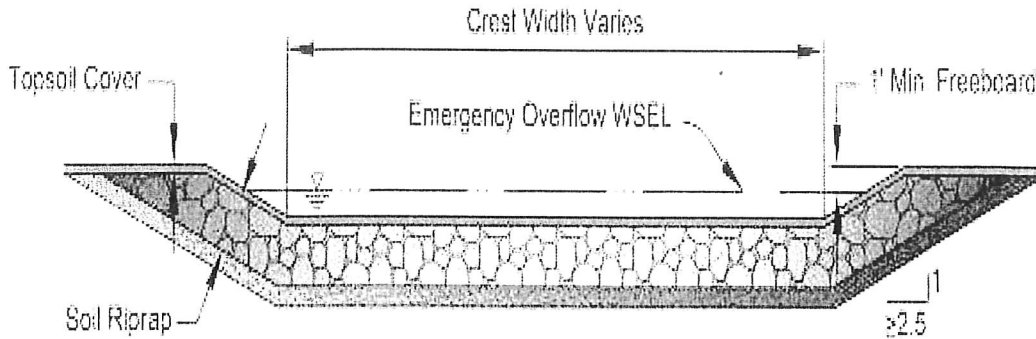
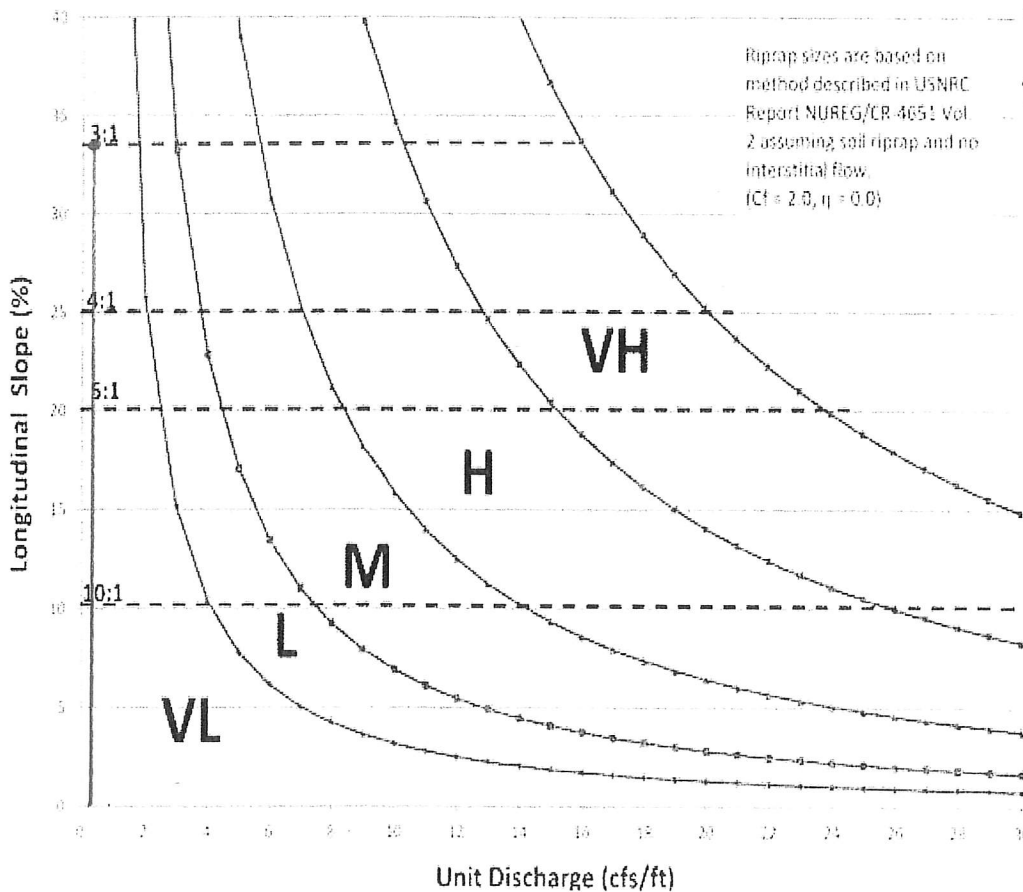

Figure 13-12d. Riprap Types for Emergency Spillway Protection



100 yr CFS @
 DP2 = 4.9 cfs
 SPILLWAY WIDTH
 = 20'
 UNIT DISCHARGE
 = 4.9 cfs / 20'
 = 0.25 cfs/ft
 SLOPE = 3:1
USE TYPE VL

Determination of Culvert Headwater and Outlet Protection

Project: **RMCC**
 Basin ID: **Pond Outfall Pipe Riprap**

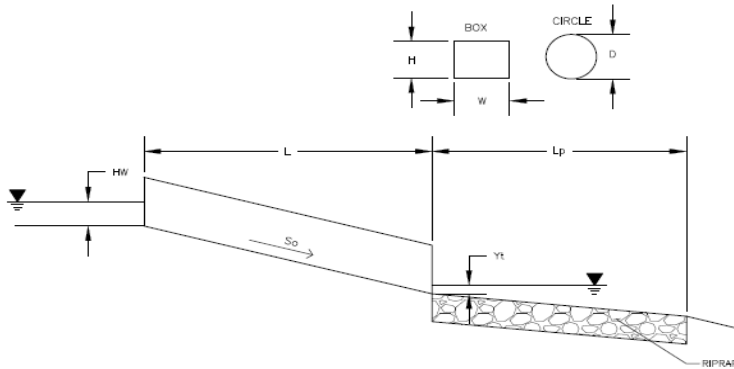

Soil Type:

Choose One:

- Sandy
 Non-Sandy

Design Information (Input):

Design Discharge	Q =	<input type="text" value="0.6"/>	cfs
Circular Culvert:			
Barrel Diameter in Inches	D =	<input type="text" value="8"/>	inches
Inlet Edge Type (Choose from pull-down list)		<input type="text" value="1.5 : 1 Beveled Edge"/>	
Box Culvert:			
Barrel Height (Rise) in Feet	Height (Rise) =	<input type="text"/>	ft
Barrel Width (Span) in Feet	Width (Span) =	<input type="text"/>	ft
Inlet Edge Type (Choose from pull-down list)		<input type="text"/>	
Number of Barrels	No =	<input type="text" value="1"/>	
Inlet Elevation	Elev IN =	<input type="text" value="92.4"/>	ft
Outlet Elevation OR Slope	Elev OUT =	<input type="text" value="91"/>	ft
Culvert Length	L =	<input type="text" value="273.6"/>	ft
Manning's Roughness	n =	<input type="text" value="0.012"/>	
Bend Loss Coefficient	k _b =	<input type="text" value="0"/>	
Exit Loss Coefficient	k _x =	<input type="text" value="1"/>	
Tailwater Surface Elevation	Elev Y _t =	<input type="text"/>	ft
Max Allowable Channel Velocity	V =	<input type="text" value="5"/>	ft/s

Required Protection (Output):

Tailwater Surface Height	Y _t =	<input type="text" value="0.27"/>	ft
Flow Area at Max Channel Velocity	A _t =	<input type="text" value="0.12"/>	ft ²
Culvert Cross Sectional Area Available	A =	<input type="text" value="0.35"/>	ft ²
Entrance Loss Coefficient	k _e =	<input type="text" value="0.20"/>	
Friction Loss Coefficient	k _f =	<input type="text" value="12.45"/>	
Sum of All Losses Coefficients	k _s =	<input type="text" value="13.65"/>	ft
Culvert Normal Depth	Y _n =	<input type="text" value="0.39"/>	ft
Culvert Critical Depth	Y _c =	<input type="text" value="0.36"/>	ft
Tailwater Depth for Design	d =	<input type="text" value="0.52"/>	ft
Adjusted Diameter OR Adjusted Rise	D _a =	<input type="text" value="-"/>	ft
Expansion Factor	1/(2*tan(θ)) =	<input type="text" value="6.09"/>	
Flow/Diameter ^{2.5} OR Flow/(Span * Rise ^{1.5})	Q/D ^{2.5} =	<input type="text" value="1.65"/>	ft ^{0.5} /s
Froude Number	Fr =	<input type="text" value="0.89"/>	
Tailwater/Adjusted Diameter OR Tailwater/Adjusted Rise	Y _t /D =	<input type="text" value="0.40"/>	
Inlet Control Headwater	HW _i =	<input type="text" value="0.52"/>	ft
Outlet Control Headwater	HW _o =	<input type="text" value="-0.26"/>	ft
Design Headwater Elevation	HW =	<input type="text" value="92.92"/>	ft
Headwater/Diameter OR Headwater/Rise Ratio	HW/D =	<input type="text" value="0.78"/>	
Minimum Theoretical Riprap Size	d ₅₀ =	<input type="text" value="1"/>	in
Nominal Riprap Size	d ₅₀ =	<input type="text" value="6"/>	in
UDFCD Riprap Type	Type =	<input type="text" value="VL"/>	
Length of Protection	L_p =	<input type="text" value="3"/>	ft
Width of Protection	T =	<input type="text" value="2"/>	ft

Design Procedure Form: Runoff Reduction

UD-BMP (Version 3.07, March 2018)

Sheet 1 of 1

Designer: TJW
Company: MVE, Inc.
Date: April 8, 2025
Project: RMCC
Location: Separate Pervious Area (SPA)

SITE INFORMATION (User Input in Blue Cells)

WQCV Rainfall Depth = 0.60 inches
 Depth of Average Runoff Producing Storm, d_6 = 0.43 inches (for Watersheds Outside of the Denver Region, Figure 3-1 in USDCM Vol. 3)

Area Type	SPA																			
Area ID	SPA																			
Downstream Design Point ID	Self																			
Downstream BMP Type	None																			
DCIA (ft ²)	--																			
UIA (ft ²)	--																			
RPA (ft ²)	--																			
SPA (ft ²)	20,888																			
HSG A (%)	100%																			
HSG B (%)	0%																			
HSG C/D (%)	0%																			
Average Slope of RPA (ft/ft)	--																			
UIA:RPA Interface Width (ft)	--																			

CALCULATED RUNOFF RESULTS

Area ID	SPA																			
UIA:RPA Area (ft ²)	--																			
L / W Ratio	--																			
UIA / Area	--																			
Runoff (in)	0.00																			
Runoff (ft ³)	0																			
Runoff Reduction (ft ³)	1044																			

CALCULATED WQCV RESULTS

Area ID	SPA																			
WQCV (ft ³)	0																			
WQCV Reduction (ft ³)	0																			
WQCV Reduction (%)	0%																			
Untreated WQCV (ft ³)	0																			

CALCULATED DESIGN POINT RESULTS (sums results from all columns with the same Downstream Design Point ID)

Downstream Design Point ID	Self																			
DCIA (ft ²)	0																			
UIA (ft ²)	0																			
RPA (ft ²)	0																			
SPA (ft ²)	20,888																			
Total Area (ft ²)	20,888																			
Total Impervious Area (ft ²)	0																			
WQCV (ft ³)	0																			
WQCV Reduction (ft ³)	0																			
WQCV Reduction (%)	0%																			
Untreated WQCV (ft ³)	0																			

CALCULATED SITE RESULTS (sums results from all columns in worksheet)

Total Area (ft ²)	20,888
Total Impervious Area (ft ²)	0
WQCV (ft ³)	0
WQCV Reduction (ft ³)	0
WQCV Reduction (%)	0%
Untreated WQCV (ft ³)	0

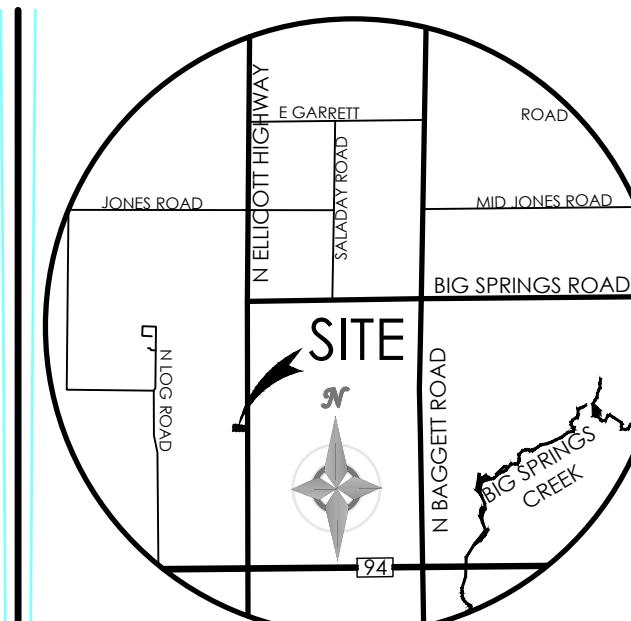

VICINITY MAP
NOT TO SCALE

BENCHMARK

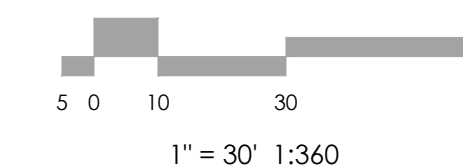
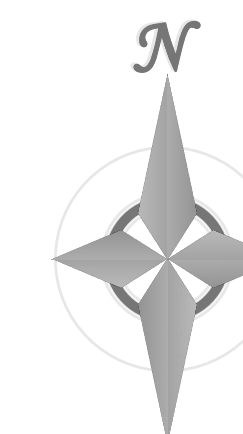

MVE, INC.
ENGINEERS, SURVEYORS

1903 Leary Street, Suite 200 Colorado Springs, CO 80909 719.635.5736

REVISIONS

DESIGNED BY
DRAWN BY
CHECKED BY
AS-BUILTS BY
CHECKED BY

ROCKY MOUNTAIN CALVARY
CHAPEL - ELLICOTT

**FINAL DRAINAGE
REPORT**
WQ TREATMENT TABLE

MVE PROJECT 61182
MVE DRAWING WQ-PP

APRIL 8, 2025
SHEET 1 OF 1

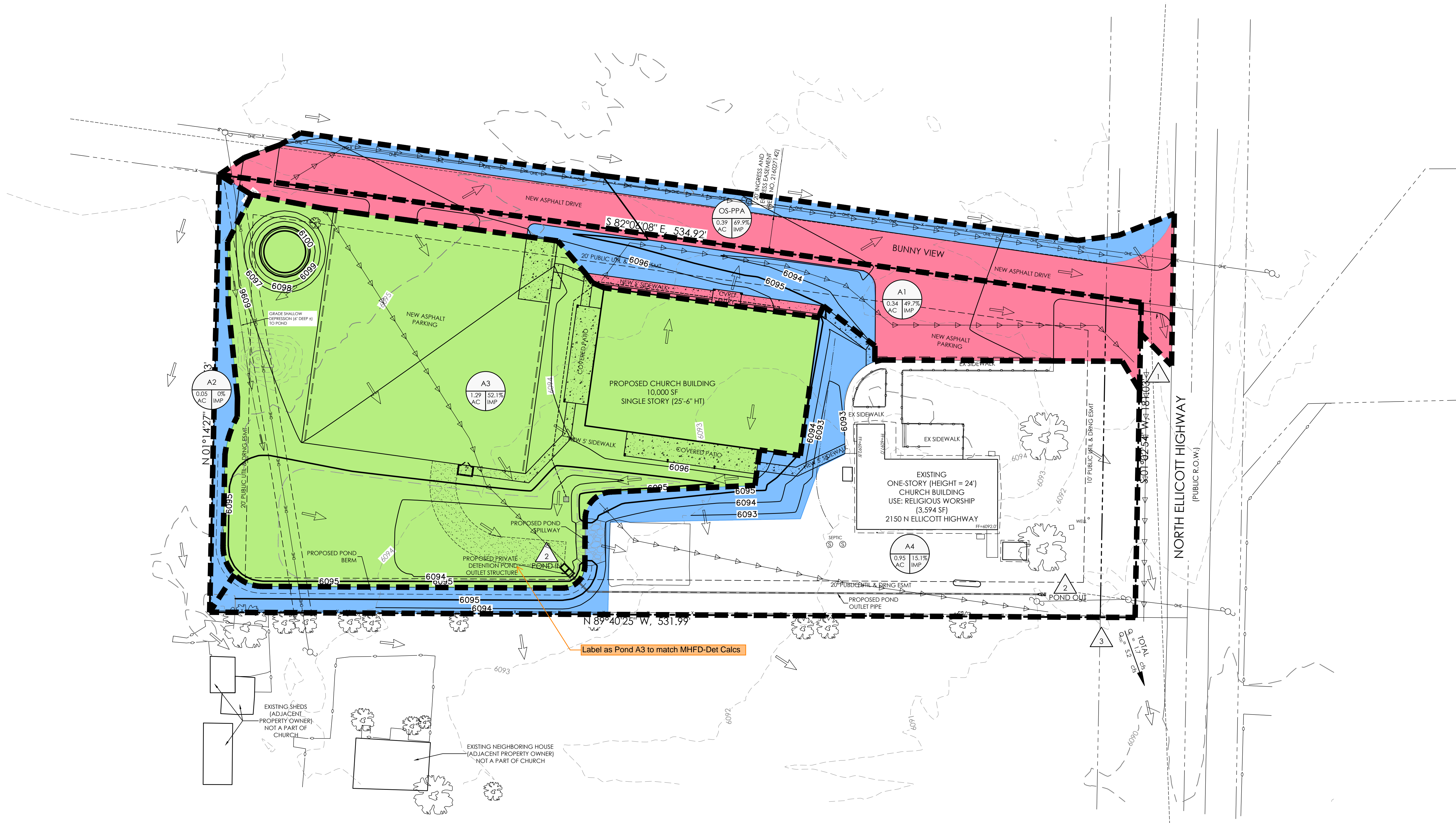

FLOODPLAIN STATEMENT

THIS PROPERTY IS LOCATED WITHIN FEMA DESIGNATED ZONE "X" (AREA OF MINIMAL FLOOD HAZARD) AS INDICATED ON THE FLOOD INSURANCE RATE MAP (FIRM) FOR EL PASO COUNTY, COLORADO AND INCORPORATED AREAS - MAP NUMBER 08041C0807G, EFFECTIVE DECEMBER 7, 2018.

LEGEND

- PROPERTY LINE
- - - EASEMENT LINE
- - - LOT LINE
- EXISTING**
- - -5985- INDEX CONTOUR
- 84- INTERMEDIATE CONTOUR
- PROPOSED**
- 5985 INDEX CONTOUR
- 84 INTERMEDIATE CONTOUR
- BASIN BOUNDARY
- Q = 19.0 cfs GENERAL FLOW/DIRECTION
- Q_{max} = 60.0 cfs
- SLOPE DIRECTION AND GRADE
- A1 BASIN LABEL
1.0 AC AREA IN ACRES
50% IMP PERCENT IMPERVIOUS
- △ DESIGN POINT
- 42.7% - AREA TRIBUTARY TO POND 1 RECEIVING WQ TREATMENT
- 15.9% - SPA 100% SELF TREATING
- 16.9% - AREA EXCLUDED FROM TREATMENT PER ECM App I.7.1.C.1
- 24.5% - UNDISTURBED

WATER QUALITY TREATMENT SUMMARY TABLE		
BASIN ID	AREA(AC.)	TREATMENT/EXCLUSION
OS-PPA	0.27	(8.9%) EXCLUDED PER ECM APP I.7.1.C.1
OS-PPA	0.12	(4.0%) SPA 100% SELF TREATING
A1	0.10	(3.3%) SPA 100% SELF TREATING
A1	0.24	(7.9%) EXCLUDED PER ECM APP I.7.1.C.1
A2	0.05	(1.7%) SPA 100% SELF TREATING
A3	1.29	(42.7%) TRIBUTARY TO POND 1
A4	0.21	(7.0%) SPA 100% SELF TREATING
A4	0.74	(24.5) UNDISTURBED AREA
TOTAL SITE AREA		3.02 ACRES

Pond A3

11 Report Maps

Existing Condition Hydraulic Analysis Map (Map Pocket)
Proposed Conditions Water Quality Area Map (Map Pocket)
Proposed Condition Hydraulic Analysis Map (Map Pocket)

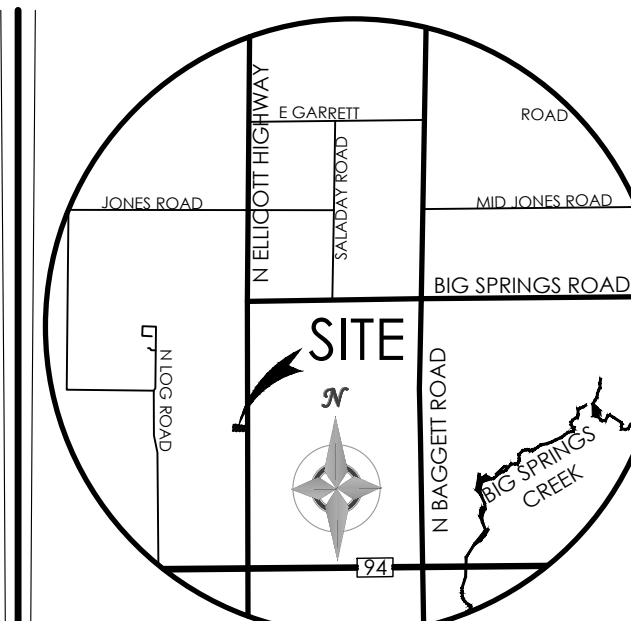

VICINITY MAP
NOT TO SCALE

BENCHMARK

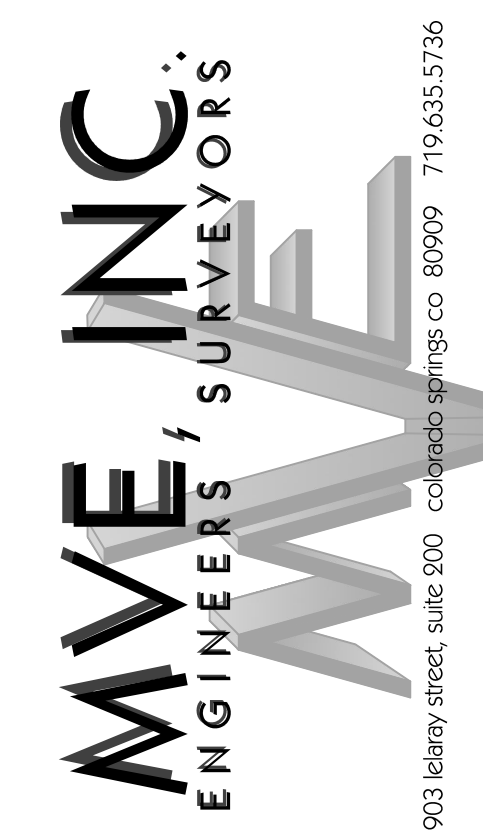
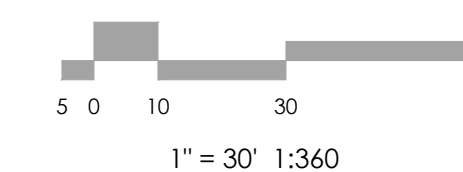
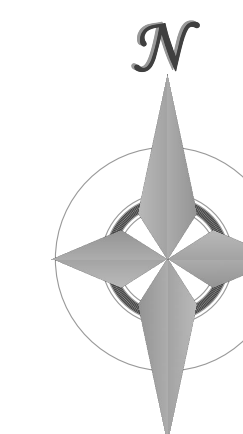

REVISIONS

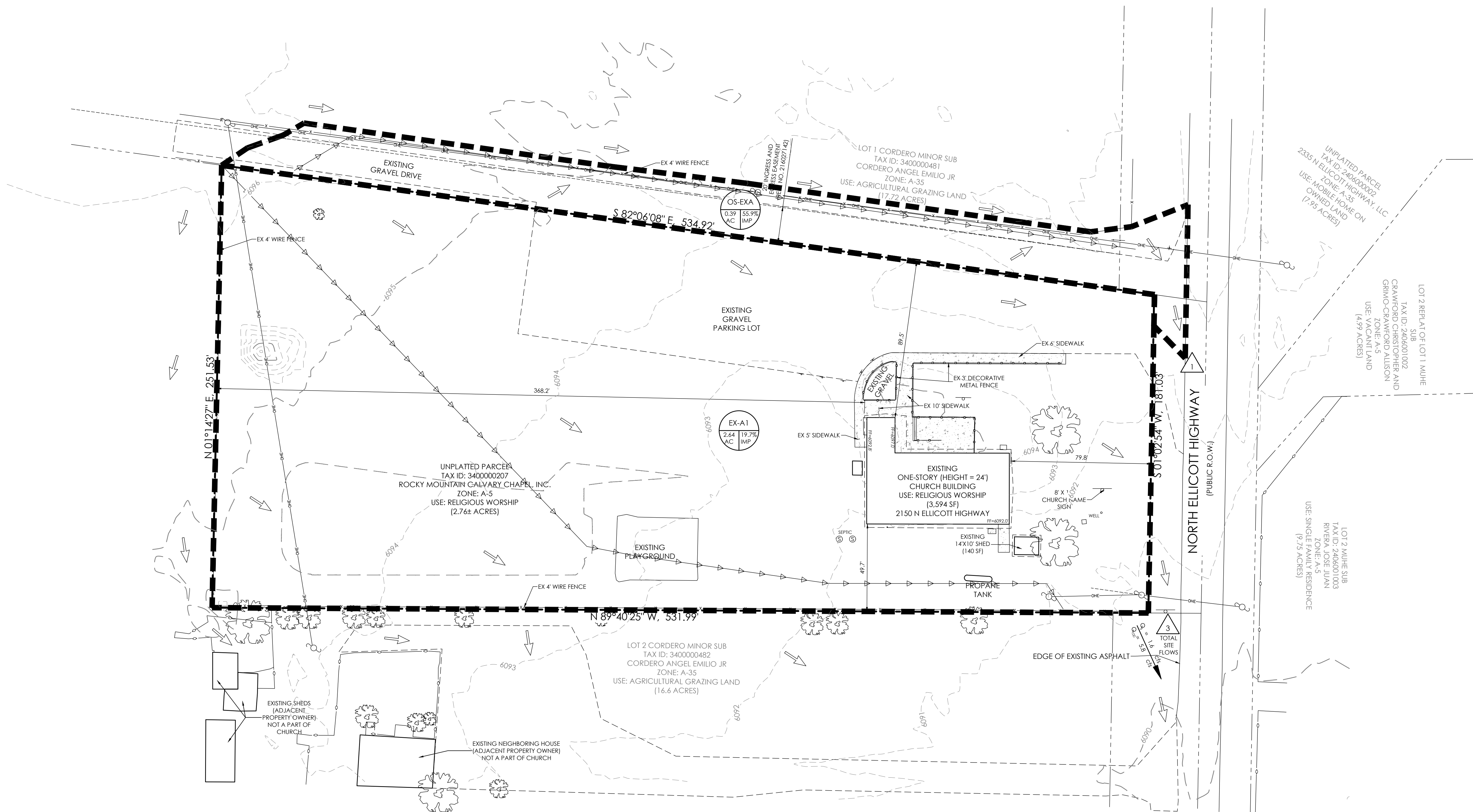

FLOODPLAIN STATEMENT

THIS PROPERTY IS LOCATED WITHIN FEMA DESIGNATED ZONE "X" (AREA OF MINIMAL FLOOD HAZARD) AS INDICATED ON THE FLOOD INSURANCE RATE MAP (FIRM) FOR EL PASO COUNTY, COLORADO AND INCORPORATED AREAS - MAP NUMBER 08041C0807, EFFECTIVE DECEMBER 7, 2018.

LEGEND

- PROPERTY LINE
- - - EASEMENT LINE
- LOT LINE
- EXISTING**
- - - INDEX CONTOUR
- - - INTERMEDIATE CONTOUR
- PROPOSED**
- - - INDEX CONTOUR
- - - INTERMEDIATE CONTOUR
- ▬ BASIN BOUNDARY
- ▬ FLOW AMOUNTS
- ▬ SLOPE DIRECTION AND GRADE
- ⊙ A1
1.0 AC
50% IMP. PERCENT IMPERVIOUS
- △ DESIGN POINT
- ← TIME OF CONCENTRATION
- FLOW DIRECTION

EXISTING DRAINAGE SUMMARY TABLE

DESIGN POINTS	INCLUDED BASINS	AREA (AC)	Tc (MIN.)	RUNOFF		METHOD
				Q5 (CFS)	QT00 (CFS)	
EX DP1	OS-EXA	0.39	19.9	0.5	1.2	RATIONAL
	EX-A1	2.64	35.7	1.2	4.4	RATIONAL
EX DP3	OS-EXA, EX-A1	3.03	35.7	1.6	5.8	RATIONAL

DESIGNED BY _____
DRAWN BY _____
CHECKED BY _____
AS-BUILT BY _____
CHECKED BY _____

ROCKY MOUNTAIN CALVARY
CHAPEL - ELLICOTT

DRAINAGE REPORT

EXISTING DRAINAGE

MVE PROJECT 61182
MVE DRAWING DRAIN-EX

DECEMBER 30, 2024
SHEET 1 OF 1

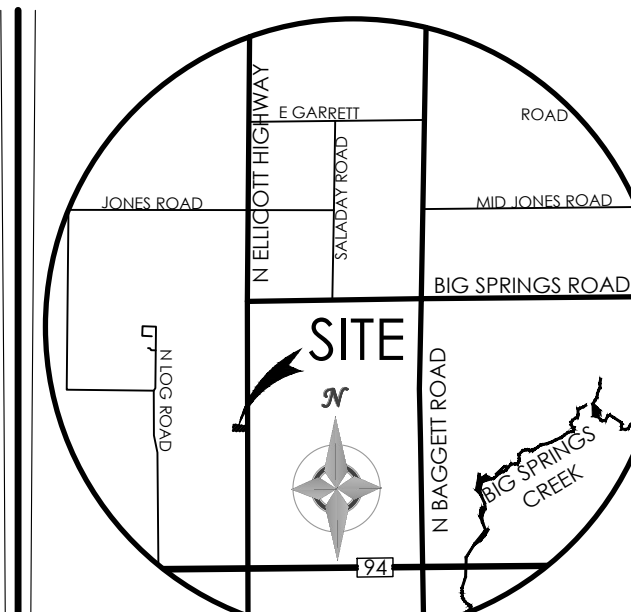

VICINITY MAP
NOT TO SCALE

BENCHMARK

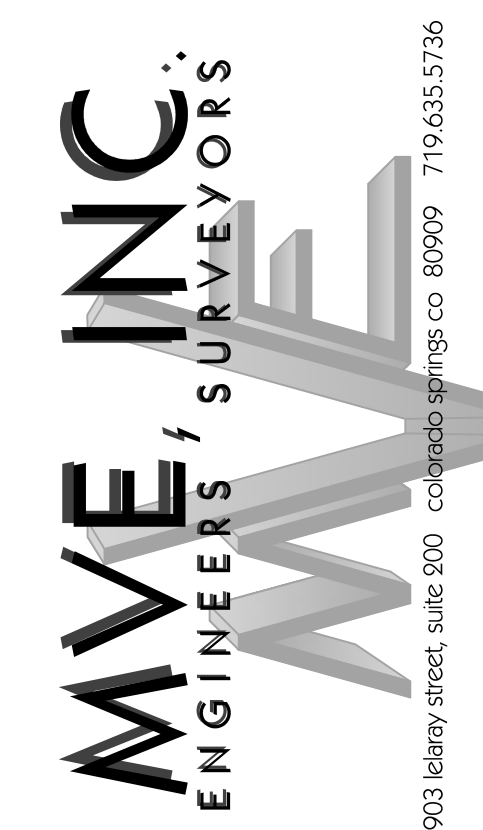
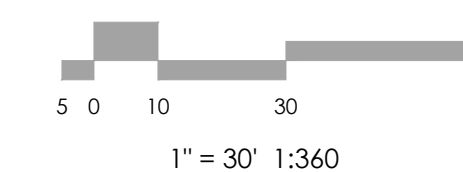
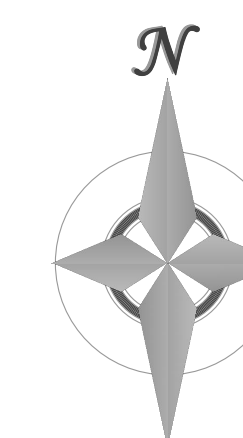

REVISIONS

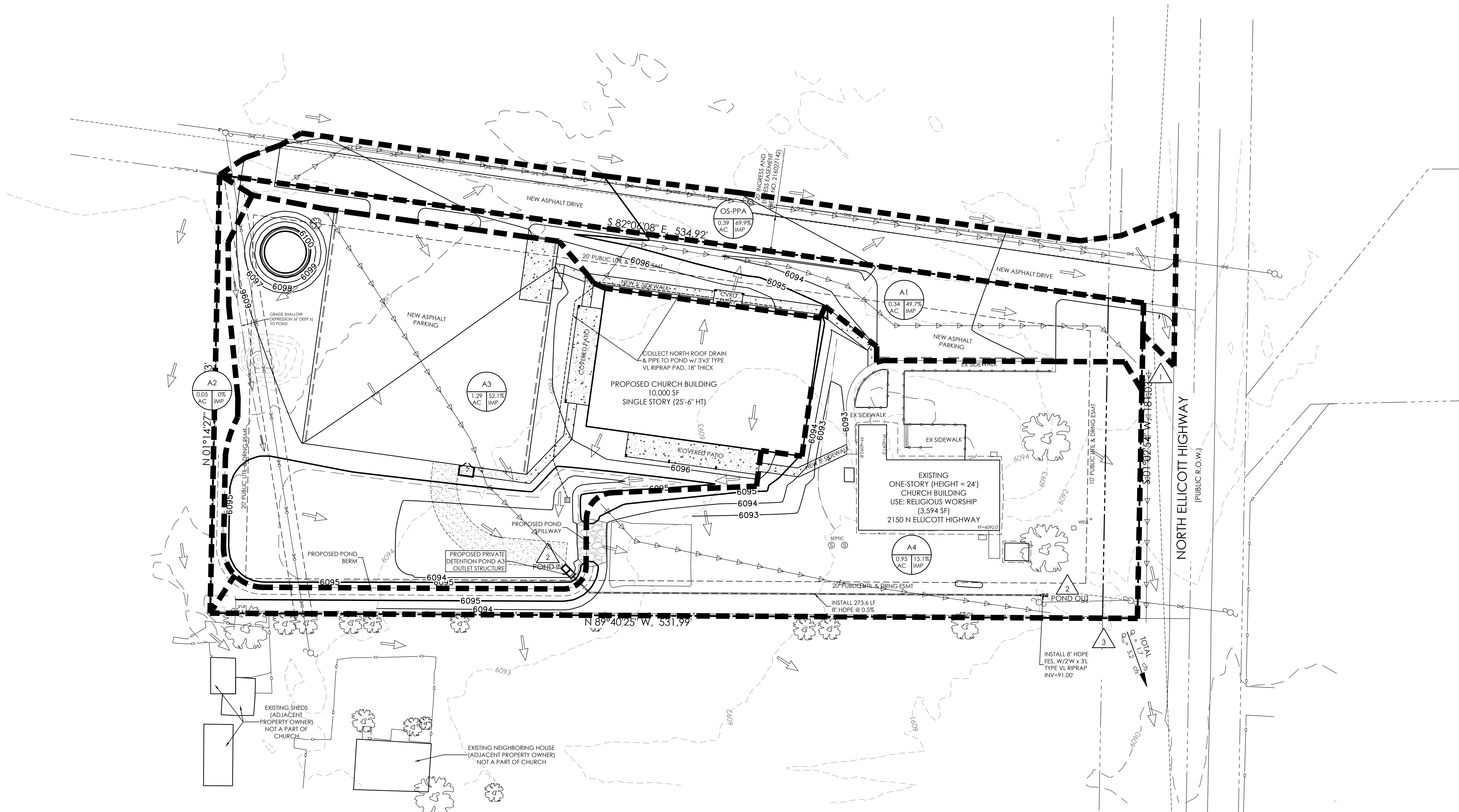

FLOODPLAIN STATEMENT

THIS PROPERTY IS LOCATED WITHIN FEMA DESIGNATED ZONE "X" (AREA OF MINIMAL FLOOD HAZARD) AS INDICATED ON THE FLOOD INSURANCE RATE MAP (FIRM) FOR EL PASO COUNTY, COLORADO AND INCORPORATED AREAS - MAP NUMBER 08041C0807, EFFECTIVE DECEMBER 7, 2018.

LEGEND

- PROPERTY LINE
- - - EASEMENT LINE
- LOT LINE
- EXISTING**
- - - INDEX CONTOUR
- - - INTERMEDIATE CONTOUR
- PROPOSED**
- - - INDEX CONTOUR
- - - INTERMEDIATE CONTOUR
- ▬ BASIN BOUNDARY
- ▬ FLOW AMOUNTS
- ▬ FLOW DIRECTION AND GRADE
- A1
1.0 AC
50% IMP
- △ DESIGN POINT
- ← TIME OF CONCENTRATION
- ← FLOW DIRECTION

PROPOSED DRAINAGE SUMMARY TABLE

DESIGN POINTS	INCLUDED BASINS	AREA (AC)	Tc (MIN.)	RUNOFF		METHOD
				Q5 (CFS)	QT00 (CFS)	
	OS-PPA	0.39	17.7	0.8	1.7	RATIONAL
	A1	0.34	5.7	0.8	1.9	RATIONAL
1	OS-PPA, A1	0.73	23.6	1.2	3.1	RATIONAL
	A2	0.05	12.0	0.1	0.1	RATIONAL
2	A3	1.29	15.7	2.2	4.9	RATIONAL
	POND OUT			0.0	0.6	
	A4	0.95	23.6	0.5	2.0	RATIONAL
3	OS-PPA, A1, A2, A4, POND OUT					
		3.03	23.6	1.7	5.2	RATIONAL

DESIGNED BY _____
 DRAWN BY _____
 CHECKED BY _____
 AS-BUILTS BY _____
 CHECKED BY _____

ROCKY MOUNTAIN CALVARY
 CHAPEL - ELLICOTT

DRAINAGE REPORT
PROPOSED DRAINAGE

MVE PROJECT 61182
 MVE DRAWING DRAIN-PP

V3 - Drainage Report - Final - RLR.pdf Markup Summary

Glenn Reese - EPC Stormwater (3)

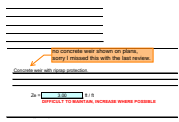

Subject: SW - Textbox with Arrow
Page Label: 52
Author: Glenn Reese - EPC Stormwater
Date: 4/8/2026 11:51:36 AM
Status:
Color: ■
Layer:
Space:

no concrete weir shown on plans, sorry I missed this with the last review.



Subject: SW - Textbox with Arrow
Page Label: 58
Author: Glenn Reese - EPC Stormwater
Date: 4/8/2026 11:55:05 AM
Status:
Color: ■
Layer:
Space:

Pond A3

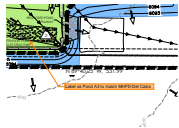

Subject: SW - Textbox with Arrow
Page Label: 58
Author: Glenn Reese - EPC Stormwater
Date: 4/8/2026 11:54:24 AM
Status:
Color: ■
Layer:
Space:

Label as Pond A3 to match MHFD-Det Calcs