

Licensee: Pike Solar, LLC
Investigation #: 2021-099
Line No.: 5129, 7015, 7017, 7051
Plat No.: 2224
License No.: 108342

File With Document #: 70163
Agent: T. Swanson
Engineer: B. Braasch
Section 26 Twp 16S Rge 65W
LandWorks No.: _____

LICENSE AGREEMENT

This LICENSE AGREEMENT is made this 17th day of September, 2021 by and between PUBLIC SERVICE COMPANY OF COLORADO, a Colorado corporation hereinafter called "PSCo" and PIKE SOLAR, LLC hereinafter called the "Licensee."

RECITALS

A. PSCo is the owner of an easement or right-of-way for utility facilities (the "Property"), and desires to protect the facilities located thereon and preserve the future use of said easement or right-of-way, which is described as a parcel of land in the SENE of Section 26, Township 16 South, Range 65 West, more particularly described in an Easement dated June 15th, 1964 in Book 2023 at Page 398 in the offices of the El Paso County, Colorado Clerk and Recorder.

B. Licensee desires to make certain improvements or installations, specifically installation of a 16-foot-wide gravel access road, in, on, under or along the Property as more particularly shown on Exhibit A attached hereto and made a part hereof ("Licensed Facility"), and desires to obtain PSCo's permission therefor.

C. PSCo is willing to consent to the Licensed Facility subject to the terms and conditions stated in this License Agreement.

AGREEMENT

NOW, THEREFORE, in consideration of the foregoing, and for other good and valuable consideration, the receipt and sufficiency of which is hereby acknowledged, the parties agree as follows:

1. PSCo hereby grants to Licensee, with respect to such title and interest as PSCo may have in the Property, and upon the terms and conditions hereinafter stated, the non-exclusive permission and right to construct, maintain, operate, repair, inspect, and remove the Licensed Facility in, on, under, or along the Property. The Licensed Facility shall be located and constructed as shown on Exhibit A and in accordance with the Plans and Specifications defined below. Road grades under the lines are not permitted. Licensee will not conduct or permit anyone to conduct any activities or install any improvements on the Property which deviate in any manner from Exhibit A without the prior written consent of PSCo. Licensee shall prepare and submit to PSCo as-built exhibit(s) depicting the Licensed Facility, and calling out all deviations from Exhibit A no later than thirty (30) days after completion of construction. The rights granted by PSCo under this

License Agreement are limited to the use by Licensee of the portion of the Property referenced on Exhibit A in connection with the Licensed Facility and for no other purpose.

2. This License Agreement does not convey an interest in real property. The parties do not by this License Agreement intend to create a lease, easement or other real property interest. Nothing contained in this License Agreement shall be deemed or construed to create a partnership or joint venture of or between PSCo and Licensee, or to create any other relationship between the parties other than that of licensor and licensee.

3. PSCo intends to use the Property for all purposes in connection with electric power generation, transmission, or distribution and/or natural gas gathering, storage, transmission, or distribution, and the rights herein granted to Licensee are subject to the rights of PSCo to use the Property for such purposes, which rights PSCo hereby expressly reserves.

4. PSCo is the owner of a limited interest in the Property. Licensee shall bear the sole obligation of obtaining from the fee owner of the Property or others owning any interest in the Property, such authority or rights as Licensee may need in addition to this license for Licensee's use of the Property. Licensee agrees that any authorization granted herein is conditioned upon Licensee obtaining such additional authorization.

5. Licensee shall not interfere with PSCo's activities or facilities on the Property, and Licensee shall construct, maintain and operate the Licensed Facility and conduct its activities in a safe and prudent manner considering overhead transmission lines located above and any other PSCo facilities located on or below the surface of the Property.

6. If PSCo determines, in its sole and absolute discretion, that the Licensed Facility may interfere with the operation and maintenance of PSCo's facilities, as now or hereafter constructed, PSCo may require relocation of the Licensed Facility, in whole or in part, by giving 90-days' notice to Licensee. Following such notice, at its sole expense, Licensee will remove and relocate the Licensed Facility from the Property or any part thereof identified by PSCo within such 90-day period. In the event that Licensee's use of the Property should, in the reasonable judgment of PSCo, constitute a hazard to PSCo's facilities or the general public, PSCo may require immediate removal, relocation, or modification of Licensee's facilities to eliminate such interference or hazard, and may suspend Licensee's right to use the Property under this License Agreement until such removal, relocation, or modification is completed. PSCo may, but is not obligated to, permit the relocation of the Licensed Facility to a different location on the Property in its sole and absolute discretion. PSCo agrees to work in good faith with Licensee to find a mutually agreeable location and configuration of Licensees facilities.

7. The license granted by this License Agreement is issued subject to any prior licenses, easements, leases or other rights affecting the Property. PSCo reserves the right to grant leases or easements and to license others to install improvements in, on, under, or along the Property provided that same shall not interfere unreasonably with the Licensed Facility. The license herein granted may also be subject and subordinate to the lien of PSCo's Indenture.

8. Licensee shall not do or permit to be done any blasting above, under, or on the Property without first having received prior written permission from PSCo, which may be withheld in PSCo's sole and absolute discretion. Any blasting shall be done in the presence of a representative of PSCo and in accordance with directions such representative may give for the protection or safety of persons and facilities located on the Property. Notwithstanding the foregoing, PSCo will have no duty to monitor any blasting activities conducted by Licensee. Any monitoring by PSCo of blasting conducted by Licensee is for the sole benefit of PSCo and shall not create any duty, obligation or liability to Licensee or any other person.

9. Licensee agrees that it shall not begin construction on the Property until Licensee first provides PSCo with detailed plans and specifications for the Licensed Facility ("Plans and Specifications"), and until such Plans and Specifications have been approved by PSCo. After PSCo's approval, no material changes, modifications or alterations may be made to the Plans and Specifications without PSCo's prior written consent. In addition, Licensee shall contact the Utility Notification Center of Colorado (1-800-922-1987) at least two working days prior to the commencement of construction on the Property to arrange for field locating of utility facilities. Further, if PSCo has constructed electric transmission facilities on the Property, Licensee shall contact PSCo's Electric Transmission Lines department at 303-273-4662 or 303-273-4665 at least four working days prior to the commencement of construction on the Property, and unless waived by said department, no construction shall be performed unless a representative of PSCo is present at the time and place of construction.

10. Licensee shall obey all PSCo written rules and regulations made known to it prior to its entry as well as reasonable oral instructions related to safety as such are made known to Licensee during its presence on the Property. Any damage to facilities on the Property as a result of the above construction shall, at PSCo's option, be paid for or repaired at the expense of Licensee. These provisions shall also apply to any other work involving construction, maintenance, operation, repair, inspection, removal, replacement, or relocation of the Licensed Facility on the Property. Notwithstanding the foregoing, PSCo will have no duty to monitor any activities conducted by Licensee. Any monitoring by PSCo of construction or other activities conducted by Licensee on or near the Property is for the sole benefit of PSCo and shall not create any duty, obligation or liability to Licensee or any other person.

11. Licensee agrees and understands that if PSCo has constructed natural gas gathering, storage, transmission, distribution, or related facilities on the Property, Licensee has been fully advised by PSCo that such natural gas facilities may now transport and may continue to transport natural gas at significant pressures. Licensee shall advise all of its employees, agents, contractors, and other persons who enter upon the Property, pursuant to the provisions of this License Agreement, of the existence and nature of such natural gas facilities and the danger and risk involved.

12. Licensee has been fully advised by PSCo that the natural gas facilities of PSCo, if located on the Property, may be subject to cathodic protection by rectifier and related anode beds. PSCo shall not be liable for stray current or interfering signals induced in the Licensed Facility as a result of the operating of PSCo's cathodic protection system.

13. Licensee agrees and understands that if PSCo has constructed electric power generation, transmission, distribution, or related facilities on the Property, Licensee has been fully advised by PSCo that such electric facilities may now transmit and may continue to transmit electric current at significant voltages, and that the conductors on electric lines may not be insulated. Licensee shall advise all of its employees, agents, contractors, and other persons who enter upon the Property pursuant to the provisions of this License Agreement, of the existence and nature of such electric facilities and the potential danger and risk involved.

14. **Release and Indemnification.**

(a) As used in this License Agreement, the term “Claims” means (1) claims, demands, liens, suits, actions, causes of action, proceedings, orders, decrees and judgments of any kind or nature whatsoever by or in favor of anyone whomsoever including claims asserted against PSCo by a federal, state or local government entity; (2) losses, liabilities, costs, damages and expenses, including attorneys’ fees, expert witness fees, consultant fees, and court and arbitration costs, at all levels, whether or not litigation or arbitration is commenced; (3) fines and penalties; (4) environmental costs, including, but not limited to, investigation, removal, remediation, and restoration costs, natural resource damages, and consultant and other fees and expenses; (5) damages of any kind, including lost profits and consequential damages; and (6) any and all other costs or expenses.

(b) As used in this License Agreement, the term “Injury” means (1) death, personal injury, or property, environmental, or natural resources damages, and any other losses, obligations or damages incurred by PSCo for which PSCo would reasonably expect to have obligations under Environmental Law as defined below; (2) loss of profits or other economic injury; and (3) disease or actual or threatened health effect.

(c) Licensee shall protect, defend, indemnify, release, save and hold harmless PSCo, its partners, directors, officers, agents, employees, successors, assigns, parents, subsidiaries, and affiliates from and against any and all Claims and threatened Claims arising from, alleged to arise from, resulting from or alleged to result from, in whole or in part, (1) this License Agreement; (2) any act or omission of Licensee, or any of Licensee’s employees, agents, contractors, consultants or any of their invitees; or (3) the presence of Licensee, or any of Licensee’s employees, agents, contractors or consultants, or any of their invitees, in upon, at or about the Property.

(d) Licensee’s duty to protect, indemnify, hold harmless, release, and defend hereunder shall apply to any and all Claims and threatened Claims, and Injury, including, but not limited to:

(i) Claims asserted by any person or entity, including, but not limited to, employees of Licensee or its contractors, subcontractors, or their employees, and federal, state, or local government;

(ii) Claims arising from, or alleged to be arising in any way from, the existence at or near the Property of (1) electric power generation, transmission, distribution, or related facilities; (2) electricity or electromagnetic fields; (3) natural gas gathering, storage, transmission, distribution, or related facilities; (4) asbestos or asbestos-containing materials.

(iii) Claims arising from the presence, release, disturbance, and/or exacerbation of any Hazardous Materials as defined below, regardless of origin, in, on, over, or around the Licensed Facility, or the off-site transportation and/or disposal of any Hazardous Materials. This indemnification and release does not apply, however, to any Claims arising out of or related to Hazardous Materials first generated, and brought onto and introduced to the Property by PSCo;

(iv) Claims arising from, or alleged to be arising in any way from, the acts or omissions of Licensee, its sublicensees, invitees, agents, or employees; and

(v) Claims occasioned by or related to an actual or alleged Injury.

(e) The term “Hazardous Materials” means any substance, pollutant, contaminant, chemical, material or waste that is regulated, listed, or identified under any Environmental Law, or which is deemed or may be deemed hazardous, dangerous, damaging or toxic to living things or the environment, and shall include, without limitation, any flammable, explosive, or radioactive materials; hazardous materials; radioactive wastes; hazardous wastes; hazardous or toxic substances or related materials; polychlorinated biphenyls; petroleum products, fractions and by-products thereof; asbestos and asbestos-containing materials; medical waste, solid waste, and any excavated soil, debris, or groundwater that is contaminated with such materials, and any other waste, material, substance, pollutant or contaminant that might subject PSCo or Licensee to any claims, demands, damages, costs, expenses or other liabilities under any Environmental Law.

(f) “Environmental Law” means any and all applicable environmental laws, whether imposed by statute or derived from common law including, but not limited to, the Toxic Substances Control Act (15 U.S.C. § 2601, et seq.), the Comprehensive Environmental Response, Compensation, and Liability Act of 1980, (42 U.S.C. § 9601, et seq.), the Solid Waste Disposal Act, as amended by the Resource Conservation and Recovery Act (42 U.S.C. § 6901, et seq.), the Hazardous Material Transportation Act, (49 U.S.C. § 5101, et seq.), the Federal Water Pollution Control Act, (33 U.S.C. § 1251, et seq.), the Clean Air Act, (42 U.S.C. § 7401, et seq.), the Low-Level Radioactive Waste Policy Act (42 U.S.C. 2021b et seq.), the Endangered Species Act (16 U.S.C. § 1531, et seq.), the Migratory Bird Treaty Act (16 U.S.C. § 703 et seq.), and applicable state counterparts, and their implementing regulations, all as amended from time-to-time, and all other comparable federal, state or local environmental, conservation or environmental protection laws, rules or regulations.

(g) Notwithstanding any provision of the foregoing that may be interpreted to the contrary, this indemnity will not apply to any Claims if and to the extent directly caused by the gross negligence or willful misconduct of PSCo. Licensee’s obligations under this Section shall survive the expiration or termination of the license and this License Agreement until satisfied.

15. Licensee shall purchase, maintain and require such insurance as shall protect Licensee and PSCo from claims, damage or liability which may in any way arise out of or be in any manner connected with the performance of this License Agreement, whether arising out of the act or failure to act of Licensee, PSCo, the direct or indirect delegee, appointee, or employee of either.

(a) This insurance shall be as specified below, and, except for worker's compensation, automobile, and professional liability insurance policies, all insurance policies shall name PSCo as an additional insured:

(i) Worker's Compensation as required by statute, and Employer's Liability Limit, in the amount of one million dollars (\$1,000,000);

(ii) Commercial General Liability Insurance, occurrence form, providing bodily injury, personal injury, and property damage liability coverage with combined single limits of not less than five million dollars (\$5,000,000);

(iii) Comprehensive Automobile Liability with combined single limits of not less than one million dollars (\$1,000,000);

(iv) Licensee shall require its contractors to carry builder's risk insurance in an amount customarily carried by prudent contractors, and workers' compensation insurance for its employees in statutory limits;

(v) The policies described herein shall be endorsed to show that the insurers waive subrogation against PSCo, its directors, officers, employees, and agents.

(b) Certificates of Insurance acceptable to PSCo shall be submitted to PSCo prior to commencement of the construction of the Licensed Facility or any sooner entry on the Property by Licensee, its agents or contractors and use of the Property by Licensee. These certificates shall contain a provision that coverage afforded under the policies shall not be canceled or modified unless and until thirty (30) days prior written notice has been given PSCo. Notwithstanding the foregoing, Licensee has a continuing obligation to provide the insurance coverage described herein and none of the insurance required herein shall be canceled, changed, or allowed to lapse.

(c) Insurance specified herein shall be minimum requirements and Licensee is responsible for providing any additional insurance deemed necessary to protect Licensee's interests from other hazards or claims in excess of the minimum coverage. The liability of Licensee is not limited to available insurance coverage.

16. Licensee shall at PSCo's option, pay for or repair any damage done to the Property as a result of the construction or operation of the Licensed Facility. In addition, after any activity by Licensee on the Property, Licensee shall restore the surface of the Property by grading and

compacting any irregularities, reseeding, and/or revegetation as required to restore the Property to its condition as existed immediately prior to the entry by Licensee, including settling. Licensee shall be responsible for properly closing or abandoning any wells installed by Licensee. Performance of restoration obligations shall be subject to the terms and conditions of Section 9 regarding Plans and Specifications.

17. Upon demand from PSCo, Licensee shall reimburse PSCo for all costs incurred for replacing and resetting any section corners, quarter corners, ownership monuments, right-of-way markers, and reference points disturbed or destroyed during the construction, maintenance, operation, repair, inspection, removal, replacement, or relocation of said facilities.

18. A copy of this License Agreement shall be on the Property at all times during construction of the Licensed Facility.

19. Upon the abandonment of the use of the Property by Licensee, the license granted in this License Agreement shall terminate. Upon expiration or termination of this License Agreement for any reason, Licensee shall remove the Licensed Facility from the Property, and shall restore the Property to the Property's condition prior to this License Agreement taking effect. Removal of the Licensed Facility and restoration shall occur prior to the expiration of this License Agreement and no later than thirty (30) days following termination of this License Agreement other than by expiration. Removal of the Licensed Facility and restoration of the Property shall be performed under the same terms and conditions as the construction of the Licensed Facility. If Licensee should fail to remove the Licensed Facility and restore the Property, PSCo may remove the same and restore the Property at the expense of Licensee. The provisions of this Section shall survive expiration or termination of this License Agreement.

20. Licensee shall pay any and all sales, use, personal property and other taxes, fees and charges imposed by any governmental authority and attributable to this License Agreement, the Licensed Facility, or the license granted hereby (collectively "Taxes"). Licensee shall pay all such Taxes directly to the taxing authority when due or, if required by PSCo, to PSCo upon demand, and shall indemnify and hold PSCo and its interest in the Property harmless from any liability or lien for any Taxes.

21. Licensee will complete installation of the Licensed Facility and shall conduct its activities on the Property in a good and workmanlike manner and in compliance with all applicable federal, state, and local laws, regulations, rules, ordinances, and other requirements of governmental authorities ("Laws") and in compliance with all of PSCo's policies and procedures that are provided to Licensee. Licensee shall maintain and operate the Licensed Facility at its sole cost and expense and in compliance with all Laws.

22. Licensee may not assign, transfer, mortgage or encumber this License Agreement or sublicense or permit occupancy or use of the Property, or any part thereof by any third party; nor shall any assignment or transfer of this License Agreement be effectuated by operation of law or otherwise (any of the foregoing being hereinafter referred to as an "Assignment"), without in each such case obtaining the prior written consent of PSCo, which consent may be withheld in

PSCo's sole and absolute discretion. The consent by PSCo to any Assignment shall not be construed as a waiver or release of Licensee from the terms of any covenant or obligation under this License Agreement. Any Assignment or attempted Assignment by Licensee without PSCo's consent will terminate the license and this License Agreement. This License Agreement shall be binding upon and inure to the benefit of the parties hereto and, subject to the restrictions and limitations herein contained, their respective heirs, successors and assigns.

23. Licensee is solely responsible for determining whether the Property is suitable for the Licensed Facility and accepts the Property "AS IS" without any express or implied warranties of any kind, including any warranty or representation of fitness for a particular purpose or any use.

24. **No Environmental Warranties.** PSCo makes no specific or implied disclosure or warranty as to the presence or location of Hazardous Materials on the Property. Licensee is aware that it is possible that Hazardous Materials could exist anywhere on or near the Property, accepts the Property "AS IS", and enters the Property at its own risk.

25. All materials, equipment, work, and installations of any nature brought upon or installed in the Property by or on behalf of Licensee shall be at the risk of Licensee. Neither PSCo nor any party acting on PSCo's behalf shall be responsible for any damage or loss or destruction of such items brought to or installed on the Property and Licensee hereby releases PSCo from all Claims arising out of loss, damage or destruction of such items.

26. Licensee shall bear the sole obligation of obtaining such other authority or rights as Licensee may need in addition to the rights provided in this License Agreement for the construction of the Licensed Facility and use of the Property.

27. **No Introduction of Hazardous Materials.** Except with the express written permission of PSCo, Licensee shall not bring onto the Property, or permit to be brought onto the Property, any Hazardous Materials, or other regulated waste or material (including but not limited to petroleum, asbestos, PCBs, coal, coal ash or coal combustion residuals) regulated by the State of Colorado, the United States government, or any other government authority with applicable jurisdiction, which has the potential to spill or be released onto the Property or adjacent areas. In the event Licensee brings Hazardous Materials onto the Property (with or without permission of PSCo), Licensee shall comply with all applicable laws, ordinances, and regulations of federal, state, and local governmental agencies related to such Hazardous Materials. Licensee shall remove such Hazardous Materials from the Property immediately upon request of PSCo. Licensee shall bear all costs related to environmental investigation, cleanup, removal, or restoration (including but not limited to any cleanup or restoration of any impacted wildlife, water, air, groundwater, natural resources, soil, or land, including, but not limited to, the Property,) incurred as a result of the presence of such Hazardous Materials on the Property, or arising out of the acts or omissions of Licensee, its agents, sublessees, invitees, or employees.

28. **Managing Hazardous Materials.** Licensee shall be responsible for properly managing, transporting, treating, storing and/or disposing of any Hazardous Materials Licensee generates at the Property in connection with the Licensed Facility and/or its activities, including the

disturbance or exacerbation of any pre-existing Hazardous Materials encountered by Licensee on the Property.

29. **Notification of Hazardous Materials.** Licensee shall notify PSCo of any Hazardous Materials that Licensee encounters on the Property immediately upon encountering the Hazardous Materials.

30. **Licensee to Operate in Accordance with Environmental Laws.** Licensee shall construct and operate the Licensed Facility and conduct all activities in accordance with applicable Environmental Law, including obtaining all required permits for its activities at the Property and signing all waste manifests. PSCo shall not be listed as a generator for any wastes generated in connection with the Licensed Facility and/or Licensee's activities.

31. The failure of PSCo at any time or times to require performance of any provision hereof, shall in no manner affect its right at a later time to enforce the same. No waiver by PSCo of the breach of any terms or covenant contained in this License Agreement, whether by conduct or otherwise, in any one or more instances shall be deemed to be construed as further or continuing waiver of any such breach or a breach of any other term or covenant of this License Agreement.

32. Nothing contained herein shall authorize a party or person or entity acting through, with or on behalf of Licensee to subject the license, the Property, or any portion thereof to mechanic's liens. If any liens are filed against the Property resulting or arising in connection with actions or agreements of Licensee, within fifteen (15) days after such filing, Licensee will release the same of record, either by payment or by providing a bond or other security satisfactory to PSCo. If Licensee fails to timely remove such lien, PSCo may, without waiving its rights and remedies based upon such breach by Licensee and without releasing Licensee from any obligation under this License Agreement, cause such liens to be released by any means PSCo deems proper, including, but not limited to, paying the claim giving rise to the lien or posting security to cause the discharge of the lien. In such event, Licensee will reimburse PSCo, on demand, for all amounts PSCo incurs (including, without limitation, the cost of a bond and reasonable attorneys' fees and costs).

33. All notices, demands, requests and other communications required or permitted under this License Agreement must be in writing and will be deemed received: (a) when personally delivered; (b) three (3) business days after deposit in the United States mail, first class, postage prepaid, registered or certified; or (c) the first business day following deposit with a recognized overnight delivery service, such as United Parcel Service or Federal Express, in each case addressed as follows:

If to PSCo: Public Service Company of Colorado
1800 Larimer Street, Suite 400
Denver, CO 80202
Attention: Siting and Land Rights
PSCo Doc No.: 108342

With a required copy to the principal address of Public Service Company of Colorado as listed with the Colorado Secretary of State.

If to Licensee: Pike Solar LLC
1710 29th Street, Suite 1068
Boulder, CO 80301
Attention: Jay Sonnenberg

With a copy to: _____

PSCo or Licensee may change its address by giving notice to the other as provided for above.

34. In addition to other rights granted to PSCo to terminate this License Agreement and/or to require the relocation or removal of the Licensed Facility, this license will automatically terminate, without compensation or liability due to Licensee, in the event of the expiration or termination of the easement or right of way held by PSCo with respect to the Property. In addition, PSCo may terminate this License Agreement and the license hereby granted, without compensation or liability to Licensee, by giving thirty (30) days prior notice of termination to Licensee upon or at any time after the occurrence of any of the following events:

(a) Any condemnation or taking, or any conveyance, transfer or other disposition in lieu or in anticipation thereof, of any material part of the Property.

(b) Any other sale, dedication to any governmental authority, or any other transfer by PSCo of any material part of the Property.

(c) The failure of Licensee to comply with any provision of this License Agreement which failure continues for ten (10) days after notice from PSCo (or such longer period of time as may be reasonably required to cure such non-compliance, not to exceed 90 days). Termination under this subsection (c) will not release Licensee from any of its obligations or liability under this License Agreement. In addition to any other right or remedy, PSCo may have under this License Agreement or at law, without waiving any Claim against Licensee, PSCo may, but is not obligated to, pay or perform any obligation of Licensee not fully or timely paid or

performed and all costs incurred by PSCo in connection therewith shall be paid by Licensee to PSCo upon demand.

35. (a) This License Agreement may be executed in two original counterparts, each of which shall be deemed an original of this instrument.

(b) This License Agreement incorporates all agreements and stipulations between PSCo and Licensee as to the Property and the Licensed Facility and no prior representations or statements, verbal or written, shall modify, supplement or change the terms of this License Agreement. The title of this document is inserted for convenience only and does not define or limit the rights granted pursuant to this License Agreement. This License Agreement consists of the document entitled "License Agreement" and Exhibits containing (i) the legal description of the Property; and (ii) a description of the Licensed Facility. No other exhibit, addendum, schedule or other attachment (collectively "**Addendum**") is authorized by PSCo, and no Addendum shall be effective and binding upon PSCo unless separately executed by an authorized representative of PSCo. This License Agreement may only be modified by a writing executed and delivered by Licensee and an authorized representative of PSCo.

(c) This License Agreement shall be governed by and construed in accordance with the laws of the state in which the Property is located, without giving effect to principles of conflict of laws.

(d) "Licensee" shall include the singular, plural, feminine, masculine and neuter. If more than one person or entity shall sign this License Agreement as Licensee, the obligations set forth herein shall be deemed joint and several obligations of each such party or entity.

(e) This License Agreement may not be recorded or filed for record in the real estate records of the County in which the Property is located, nor in any other public office or records. In the event Licensee records or files this License Agreement, this License Agreement shall automatically terminate.

36. Licensee shall reimburse PSCo for all reasonable costs incurred by PSCo in connection with this License Agreement and/or the Licensed Facility, including without limitation, (a) in-house or third party costs incurred in connection with the review of Exhibit A and the Plans and Specifications (including revisions or modifications thereof); and (b) attorney fees and costs incurred in the administration and enforcement of this License Agreement, irrespective of whether Licensee is in default.

37. Licensee's covenants, agreements, and indemnity obligations shall survive the expiration or termination of this License Agreement.

IN WITNESS WHEREOF, this instrument has been executed the day and year first above written.

PUBLIC SERVICE COMPANY OF COLORADO,
a Colorado corporation

By: Nichole Miller
Nichole Miller, PMP
Manager, Siting & Land Rights

Xcel Energy Services, Inc.
As authorized Agent for Public Service Company of Colorado

Agreed to and accepted by Licensee this 17th day of September 2021.

Pike Solar, LLC

Michael J. Martin, President

NAME AND TITLE OF SIGNEE (Type or Print)



SIGNATURE

1710 29th Street, Suite 1068

Street Address

Boulder, CO 80305

City, State Zip

(720) 838-2338

Area Code and Telephone Number

EXHIBIT A

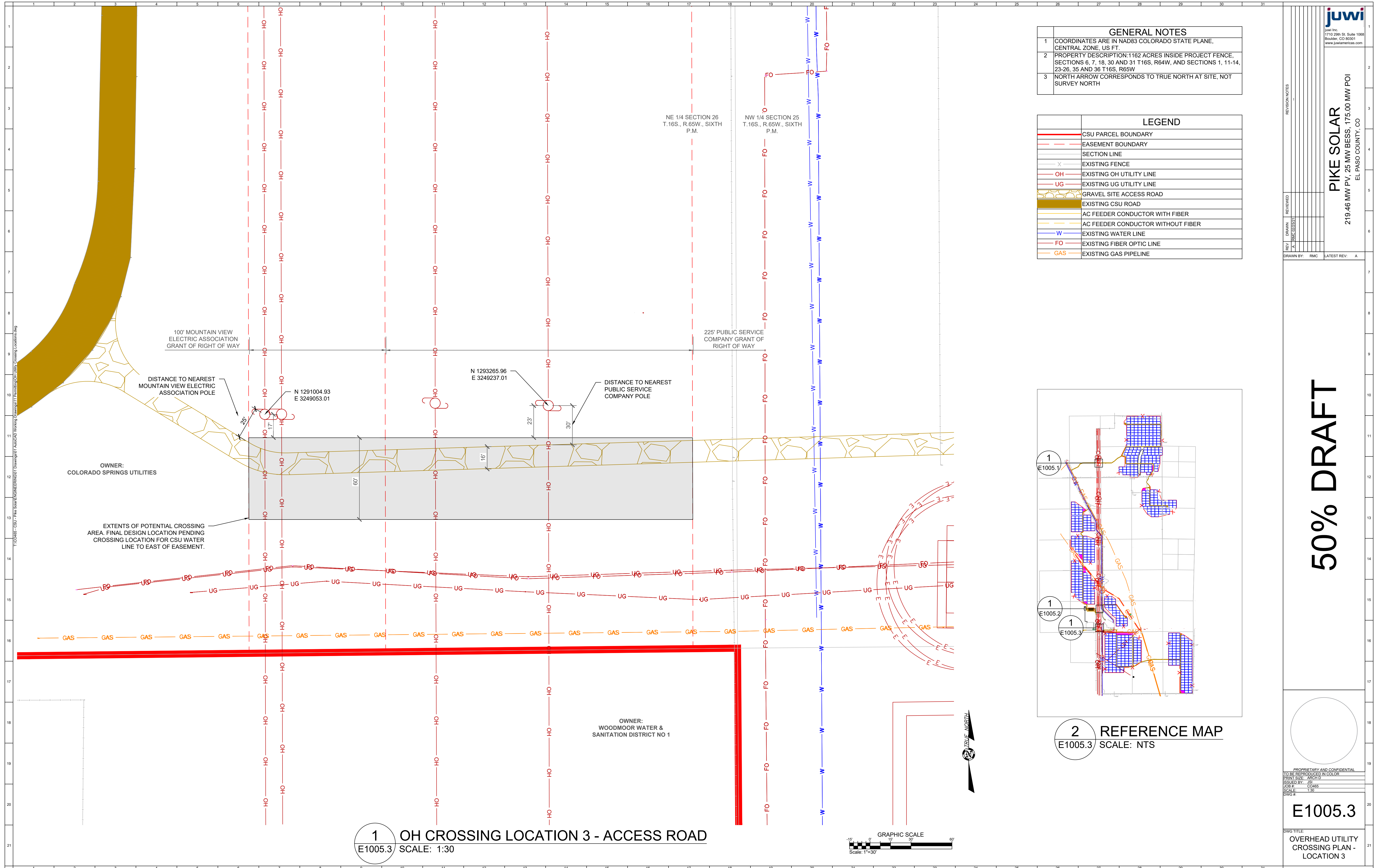

GENERAL NOTES	
1	COORDINATES ARE IN NAD83 COLORADO STATE PLANE, CENTRAL ZONE, US FT.
2	PROPERTY DESCRIPTION: 1162 ACRES INSIDE PROJECT FENCE, SECTIONS 6, 7, 18, 30 AND 31 T.16S., R.64W., AND SECTIONS 1, 11-14, 23-26, 35 AND 36 T.16S., R.65W.
3	NORTH ARROW CORRESPONDS TO TRUE NORTH AT SITE, NOT SURVEY NORTH

LEGEND	
	CSU PARCEL BOUNDARY
	EASEMENT BOUNDARY
	SECTION LINE
	EXISTING FENCE
	EXISTING OH UTILITY LINE
	EXISTING UG UTILITY LINE
	GRAVEL SITE ACCESS ROAD
	EXISTING CSU ROAD
	AC FEEDER CONDUCTOR WITH FIBER
	AC FEEDER CONDUCTOR WITHOUT FIBER
	EXISTING WATER LINE
	EXISTING FIBER OPTIC LINE
	EXISTING GAS PIPELINE

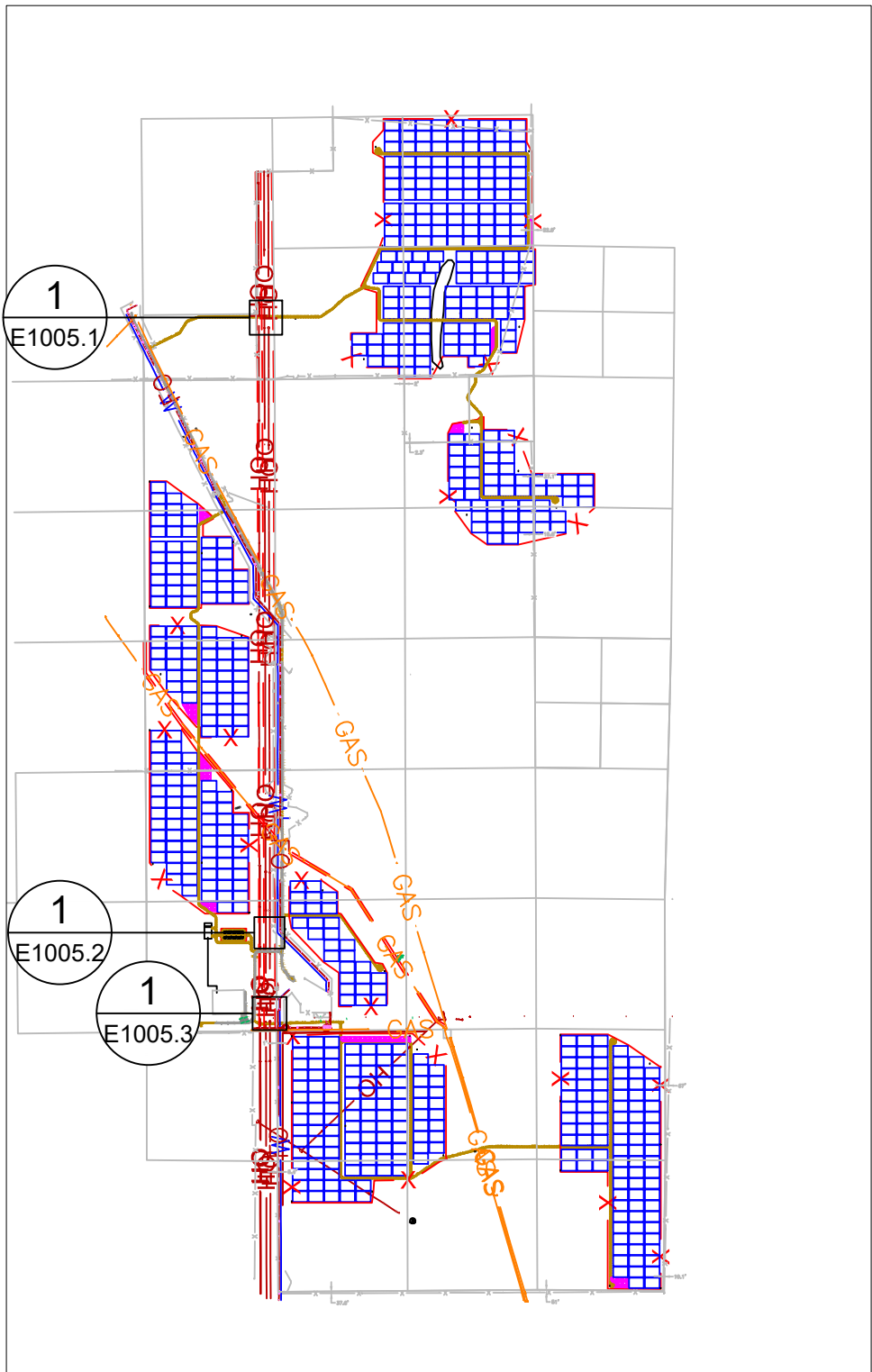

2 REFERENCE MAP
E1005.3 SCALE: NTS

1 OH CROSSING LOCATION 3 - ACCESS ROAD
E1005.3 SCALE: 1:30

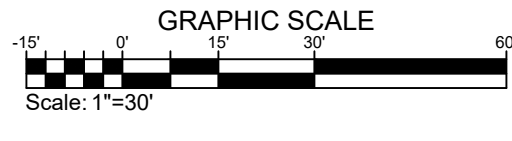

juwi
juwi inc.
1710 29th St. Suite 1068
Boulder, CO 80301
www.juwiinc.com

PIKE SOLAR
219.46 MW PV, 25 MW BESS, 175.00 MW POI
EL PASO COUNTY, CO

50% DRAFT

PROPRIETARY AND CONFIDENTIAL
DO NOT REPRODUCE OR RERENDER
PRINT SIZE: ARCH-D
ISSUED BY: JWC
SCALE: 1:30
DWG #

E1005.3

DWG TITLE:
OVERHEAD UTILITY CROSSING PLAN - LOCATION 3

REV.	DATE	BY	APP.	DESCRIPTION
A		SAM		INITIAL RELEASE

DRAWN BY: SAM LATEST REV: A

50% DRAFT

PROPRIETARY AND CONFIDENTIAL
 TO BE REPRODUCED IN COLOR
 PRINT SIZE: ARCH D
 DESIGNED BY: JSC
 DATE: 04/26/23
 SCALE: 1"=1'-0"
 DWG #

E301

DWG TITLE:
 SITE PLOWING SECTIONS

GENERAL NOTES

- NUMBER OF CABLES MAY VARY THROUGHOUT THE LENGTHS OF TRENCHES. THE SECTIONS HERE ARE ONLY REPRESENTATIVE OF THE TYPES OF CABLES, BACKFILL MATERIAL, AND MINIMUM BURIAL DEPTHS. REFER TO CABLE SCHEDULE FOR QUANTITIES.
- MAXIMUM DEPTH TOLERANCE FOR EACH EXCAVATED TRENCH SHALL BE -0", +3".
- MAXIMUM DEPTH TOLERANCE FOR EACH PLOWED CABLE SHALL BE -0", +24".
- WHERE PLOWED CABLES ARE NOT FEASIBLE DUE TO SOIL CONDITIONS, TRENCHES SHALL BE EXCAVATED

KEY NOTES

- TRENCH WIDTH MAY VARY BASED ON NUMBER OF CONDUCTORS AND OPERATION OF CONDUIT PLOWING. OVERALL WIDTH SHALL BE ADJUSTED BASED ON NUMBER OF CONDUCTORS.
- ONE STRIP OF DETECTABLE WARNING TAPE PER EVERY 2' OF INSTALLED CABLE WIDTH.
- WHEN EXCAVATING, LOCATIONS WHERE THE NATIVE SOIL IS ROCKY OR CONTAINS MATERIAL THAT MAY DAMAGE THE CABLE, THE MINIMUM DISTANCE FROM ALL EDGES OF CABLES (EXCLUDING GROUND CABLES) TO THE EDGE OF SAND / NATIVE SOIL IS 4".
- MV AC CABLES TO BE INSTALLED IN TREFOIL CONFIGURATION. WHEN INSTALLED IN OPEN TRENCH, ZIP TIES TO BE ADDED EVERY 5 FT TO MAINTAIN TREFOIL SHAPE.
- MV AC CIRCUITS WITH MORE THAN ONE CONDUCTOR PER PHASE SHALL BE INSTALLED SUCH THAT EACH TREFOIL BUNDLE OF THREE CABLES CONTAINS EACH PHASE (A, B, AND C).
- CABLE TYPES AND QUANTITIES INSTALLED IN EACH PLOW PATH OR TRENCH SHALL BE ACCORDING TO THE CABLE SCHEDULE FOUND ON DWG EXXX.

LEGEND

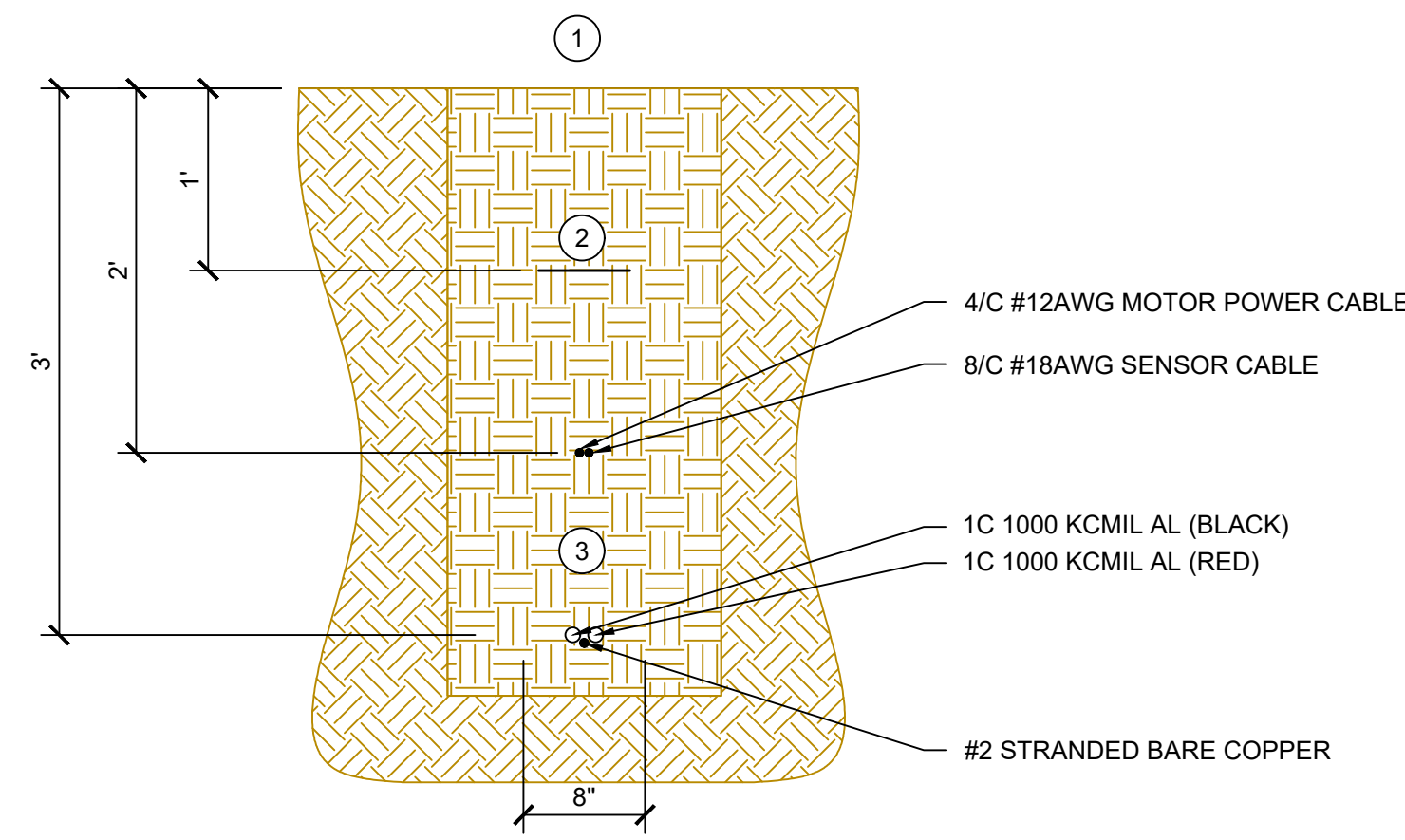
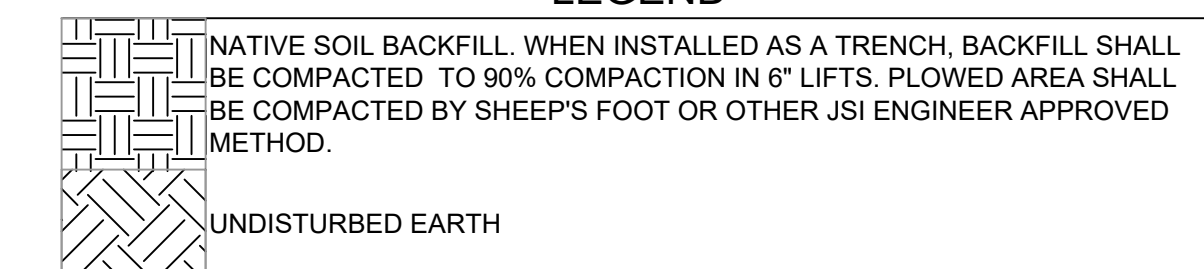

1 1000 KCMIL DC FEEDER & MOTOR CABLE PLOW SECTION
 E301 SCALE: 1" = 1'-0"

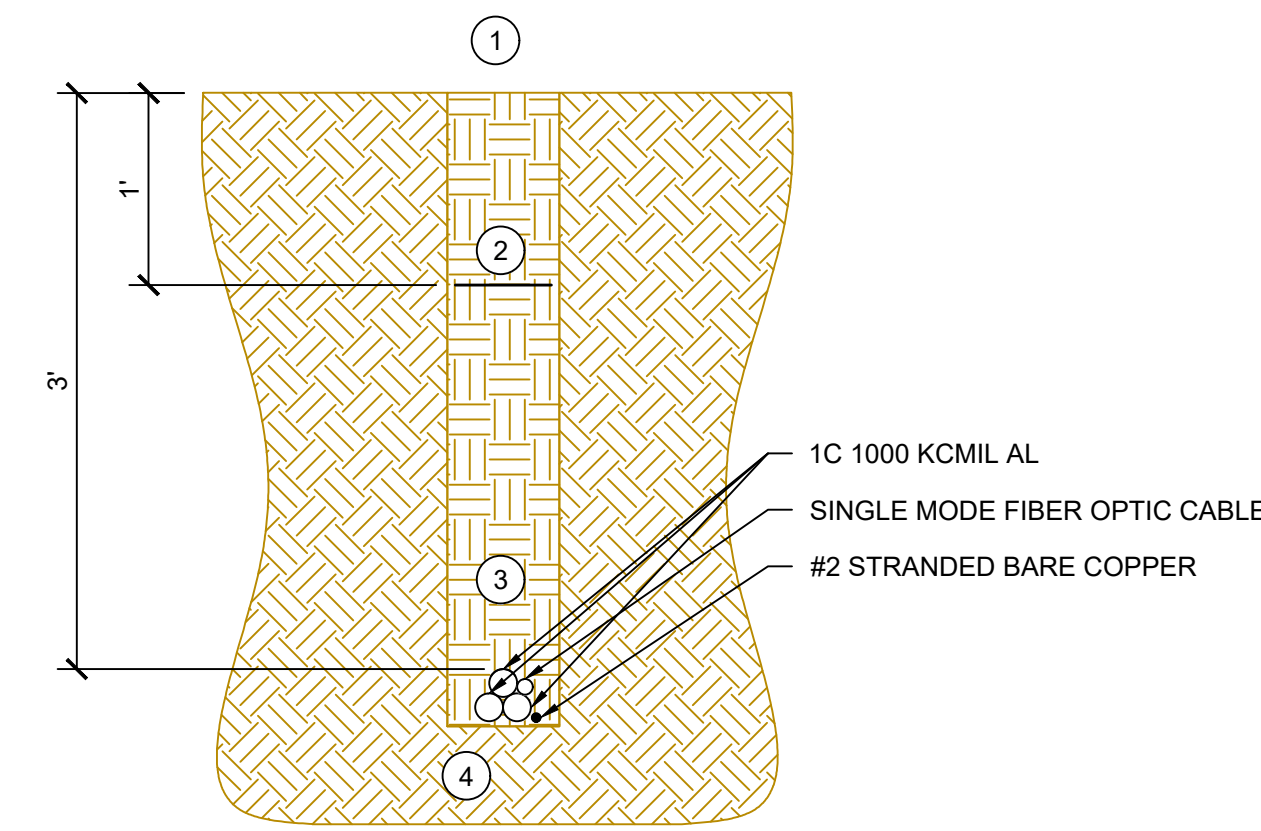

2 500 KCMIL MV AC & FIBER CABLE PLOW SECTION
 E301 SCALE: 1" = 1'-0"

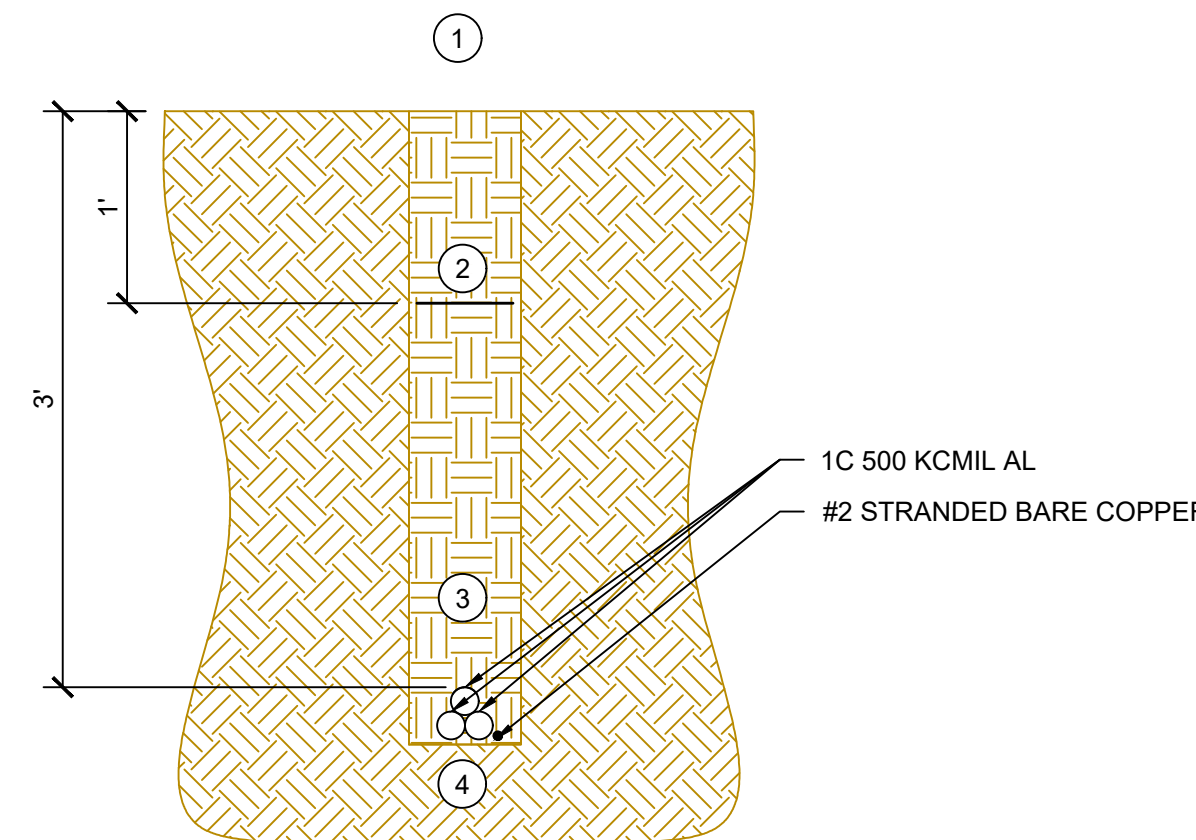

3 4/0 AWG AC FEEDER CABLE PLOW SECTION
 E301 SCALE: 1" = 1'-0"

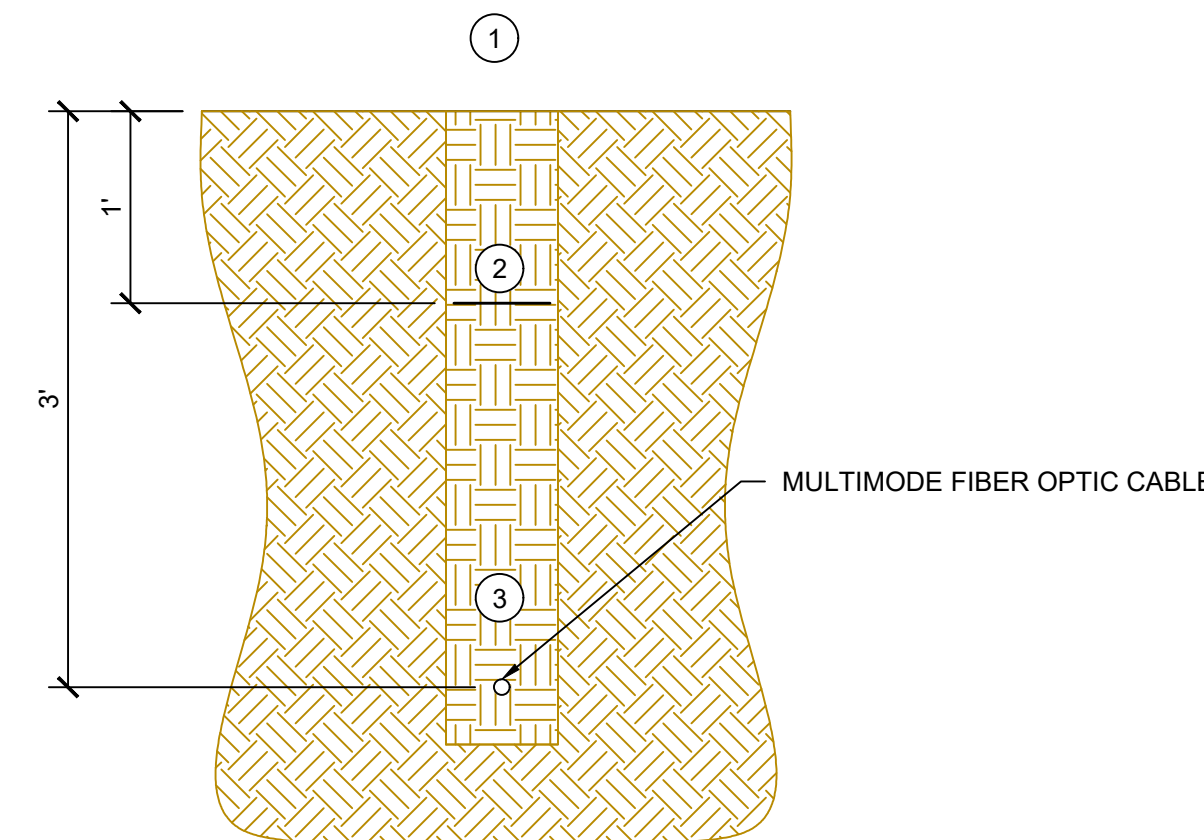

4 FIBER OPTIC CABLE PLOW SECTION
 E301 SCALE: 1" = 1'-0"

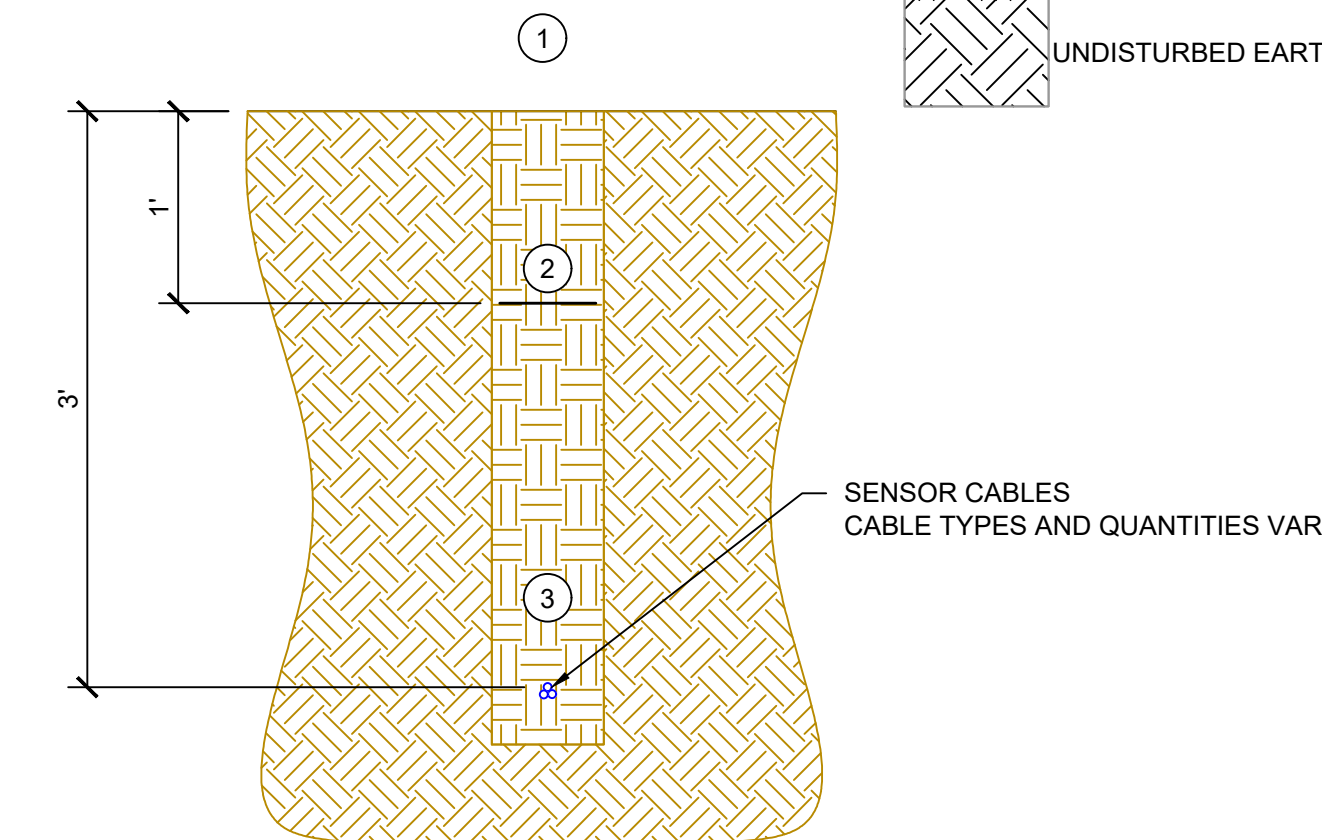

5 SENSOR CABLE PLOW SECTION
 E301 SCALE: 1" = 1'-0"

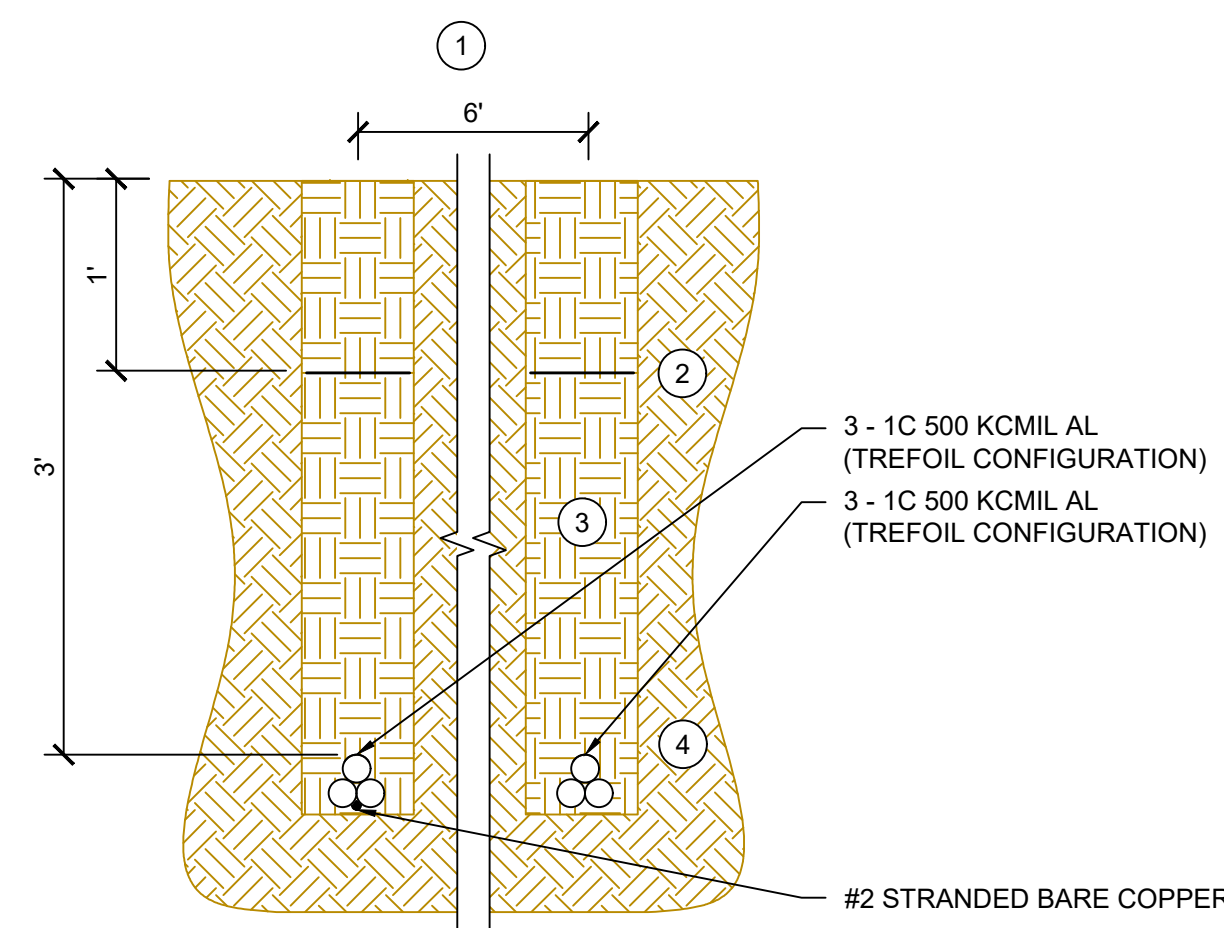

6 2/C PER PHASE 500KCMIL AC FEEDER CABLE PLOW SECTION
 E301 SCALE: 1" = 1'-0"

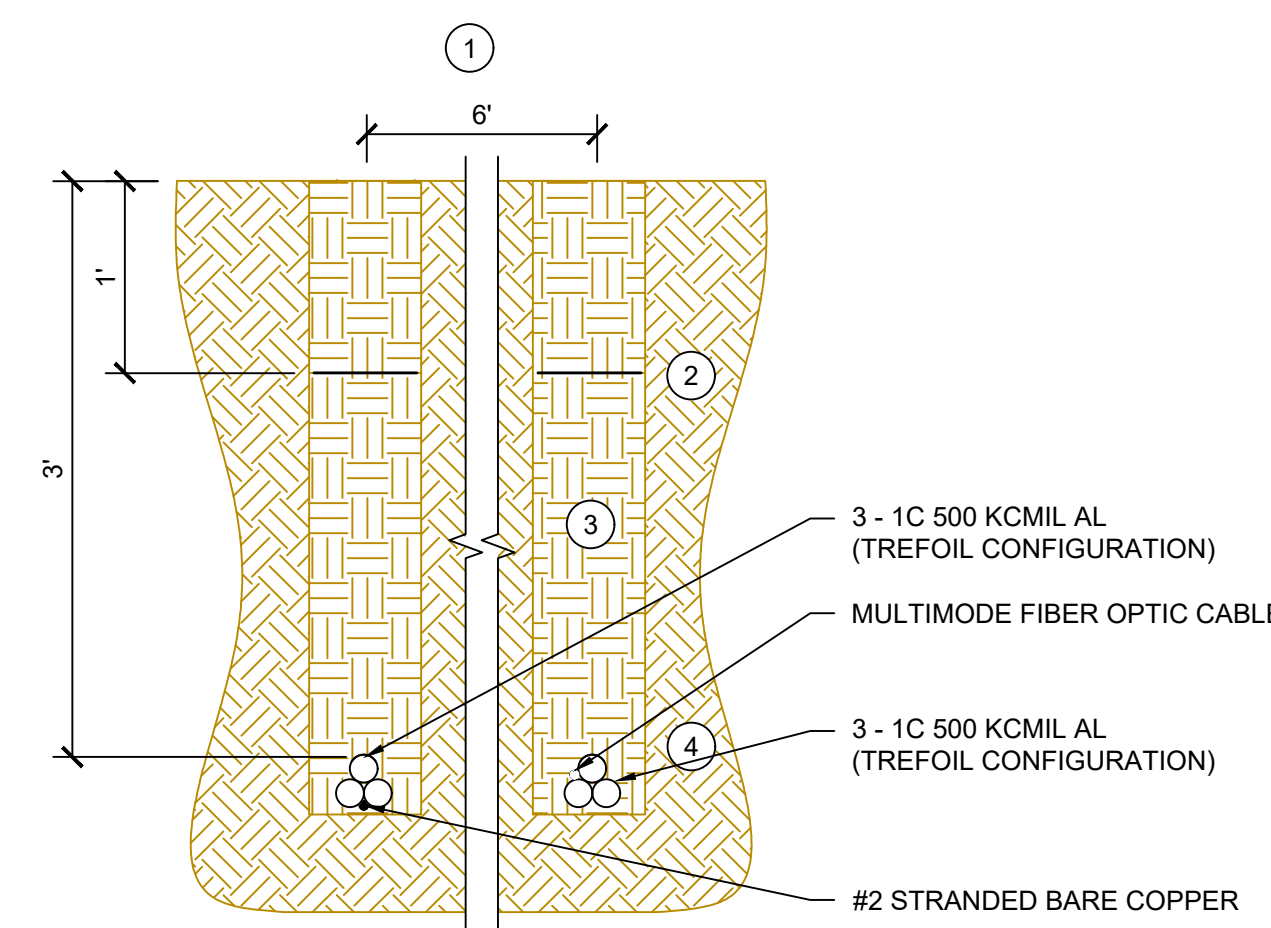

7 2/C PER PHASE 500KCMIL AC FEEDER WITH FIBER CABLE PLOW SECTION
 E301 SCALE: 1" = 1'-0"

- LEGEND**
- FOUND MONUMENT (ALIOQU)
 - 1 30" #6 REBAR W/ 3-1/2" ALUMINUM CAP, PLS. 38160, FLUSH
 - △ SET GRAVING CONTROL POINT
 - FOUND MONUMENT (NO NOTICES)
 - 1 #4 REBAR W/ 1-1/2" HD; PLASTIC CAP, PLS. 38160, FLUSH
 - STORM MARKER
 - WATER VALVE
 - WATER MANHOLE
 - WATER MARKER
 - WATER WELL
 - ELECTRIC MANHOLE
 - GUYWIRE
 - UTILITY POLE
 - FIBEROPTIC MARKER
 - FIBEROPTIC VAULT
 - GAS MARKER
 - GAS TEST STATION

- CULVERT
- WATER LINE (UNDERGROUND)
- GAS LINE (UNDERGROUND)
- E-ELECTRIC LINE (UNDERGROUND)
- E-ELECTRIC LINE (OVERHEAD)
- F-FIBEROPTIC LINE (UNDERGROUND)
- CHAIN LINK FENCE
- BARB WIRE FENCE
- CONCRETE AREA

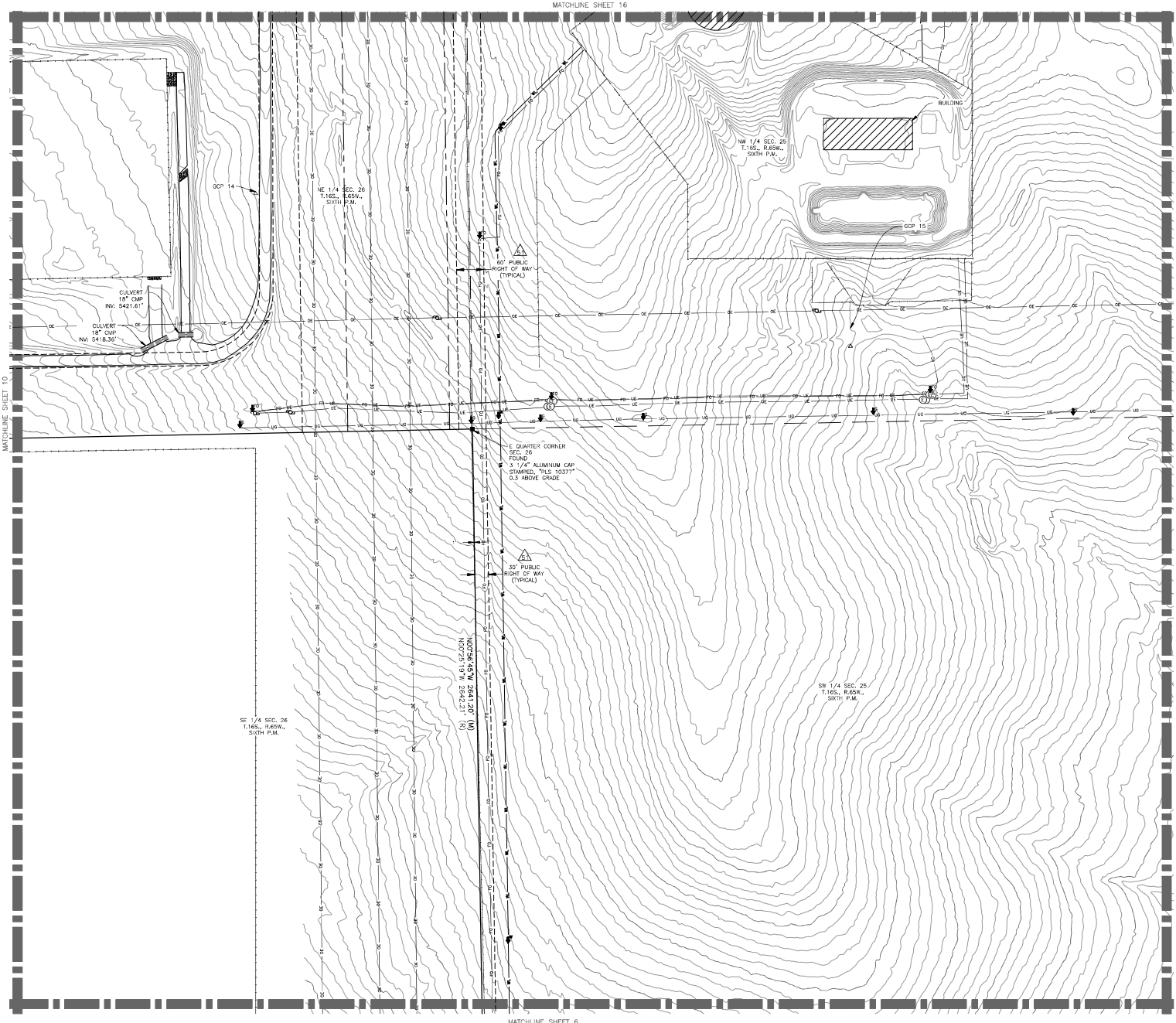
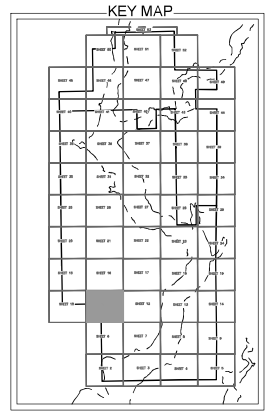
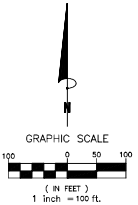

No.	Description	By	Date
3	Addressed client comments-added access road	NJM	02/02/2021
2	Add title commitment	NJM	01/19/2021
1	Addressed client comments	SOG	11/27/20

Notice: According to Colorado law you must certify that the work shown on this drawing was prepared by you or under your direct supervision and that you are a duly licensed professional engineer in the State of Colorado. If you first discover such defects in no event may you be commenced more than ten years from the date of the certification shown herein.

ALTAMPS LAND TITLE SURVEY
 A POR. OF SEC. 7, 18, 19, 30, 31 T.16S., R.64W., AND A POR. OF SEC. 11, 12, 13, 14, 23, 24, 25, 26, 35, & 36 T.16S., R. 65W., 6TH P.M. EL PASO COUNTY, COLORADO.
 Project No. 190517
 Drawn By: SOG
 Checked By: NJM
 Date: 10/9/2020
 Sheet 11 of 56

XCEL ENERGY/PUBLIC SERVICE COMPANY OF COLORADO

HIGH VOLTAGE ELECTRIC TRANSMISSION LINE

CLEARANCE REQUIREMENTS

FOR YOUR SAFETY

When working near or under a high voltage electric transmission line, it must be assumed the transmission line is energized, and any workers may not be closer than twenty feet (20') in any direction to the energized transmission lines or conductors. The Xcel Energy/Public Service Company of Colorado Electric Transmission Line Operations Department must be contacted at 303-273-4662 or 303-273-4665 a minimum of 31 days in advance to arrange for a Patrolman to be on site during any construction work within an electric transmission line right-of-way. Safety provisions will allow for operations in accordance with Occupational Safety and Health Act requirements.

When determined to be necessary, the Electric Transmission Line Patrolman will arrange for an outage of the electric lines. Any outage is a day-to-day situation, with the Patrolman on the job site at all times. When the Patrolman has arranged for an outage, any workers must be no closer than three feet (3') in any direction from the de-energized lines or conductors. There is a fee charged when an electrical clearance is required or the patrolman is on site for more than four hours.

Under **NO** circumstances may work be started within twenty feet (20') in any direction of the transmission lines or conductors without clearance from the Patrolman. It is the responsibility of the party in charge of the work or contractor to notify the Patrolman whenever starting and ending the work.

When an encroachment of any electric transmission line right-of-way is proposed, it is necessary to request a review of all details to ensure compliance with the National Electric Safety Code. Approved encroachments shall be documented with a fully executed License Agreement. For encroachment review and approval, please call (303) 571-7799.

**PLAN AHEAD AND
FOLLOW THESE INSTRUCTIONS – IT COULD SAVE A LIFE**