

**STORMWATER MANAGEMENT PLAN (SWMP)  
STORMWATER BEST MANAGEMENT PRACTICES**

**For:**

**HOMESTEAD AT STERLING RANCH FIL. 2**

**Located at:**

**~Vollmer Road North of Woodmen Road**

**Prepared For:**

**Developer: SR Land, LLC, 20 Boulder Crescent, Ste 200, Colorado Springs, CO  
80903, Contact: Jim Morley, 719-491-3024**

**Contractor: SR Land, LLC, 20 Boulder Crescent, Ste 200, Colorado Springs, CO  
80903, Contact: Chaz Collins, 719-491-8717**

**Stormwater Manger: SR Land, LLC, 20 Boulder Crescent, Ste 200, Colorado  
Springs, CO 80903, Contact: Chaz Collins, 719-491-8717**

**Prepared For:**

**SR Land, LLC**

**20 Boulder Crescent, Ste 200  
Colorado Springs, CO 80903**

**Contact: Chaz Collins  
719-491-8717**

**Prepared by:**



**CIVIL CONSULTANTS, INC.**

**M&S Civil Consultants, Inc.  
102 E. Pikes Peak, Suite 500  
Colorado Springs, CO 80903**

**Job. No. 90-007  
Project #SF-19-004**

**Engineering Review**

**04/09/2020 8:46:04 PM**

**dsdrice**

**JeffRice@elpasoco.com**

**(719) 520-7877**

**EPC Planning & Community  
Development Department**

# TABLE OF CONTENTS ✓

Table of Contents	1
<b>Stormwater Management Plan</b>	
General Site Description	2
Existing Site Conditions	2
Soils	2
Soil Erosion Potential	3
Phasing Plan	3
Water Quality	3
Narrative Description of BMP Control Measures	4
Timing Schedule	4
Areas of Disturbance	5
Permanent Stabilization	5
Owners Inspections and Maintenance of BMP's	5
Soils Borings / Test and Groundwater	6
Site Run-off Characteristics	6
<b>Stormwater Management Plan</b>	
Introduction	7
Floodplain Statement	7
Receiving Waters Descriptions	7
Existing Vegetation Description	8
Potential Pollution Sources	8
Anticipated Non-Stormwater Discharges	8
<b>Erosion Sediment Controls</b>	
Proposed Sequence of Construction Activities	8
Structural Practices	8
Non-Structural Practices	9
Materials Handling and Spill Practices	9
Potential Pollution Sources	9
Selecting Post-Construction BMPs	10
Inspections	10
Record Keeping	10

## APPENDICES

Copy of CDPHE Application	
Vicinity Map	
Grading, Erosion, Stormwater Inspection Checklist	
Spill Cleanup Instructions and Report Form	
BMP Construction Details ✓	
SWMP Grading and Erosion Control Plans ✓	



# **STORMWATER MANAGEMENT PLAN (SWMP)**

## ***General Site Description***

Homestead at Sterling Ranch Filing No. 2 is located in the SE ¼ of the NW ¼, the SW ¼ of the NE ¼, and the NW ¼ of the NE ¼ of Section 33, Township 12 South, Range 65 West of the 6<sup>th</sup> Principal Meridian, and the NE ¼ of the SW ¼ of Section 33, Township 12 South, Range 65 West of the 6<sup>th</sup> Principal Meridian within unincorporated El Paso County, Colorado. The site is bound on the south by an existing detention pond, to the north by Briargate Parkway and to the east by Sand Creek. Existing Dines Boulevard runs along the western site boundary. An existing residential development, Homestead at Sterling Ranch Filing No. 1, bounds the site to the west and a future commercial parcel bounds the site to the northwest. Sterling Ranch lies within the Sand Creek Drainage Basin. Flows from this site are tributary to Sand Creek.

Homestead at Sterling Ranch Filing No. 2 consists of 29.658 acres and is presently undeveloped. Vegetation is sparse, consisting of native grasses. Existing site terrain generally slopes from north to southwest at grade rates that vary between 2% and 6%.

Land use for Homestead at Sterling Ranch Filing No. 2 is currently listed as AG (Grazing Land). Improvements proposed for the site include paved streets, trails, a full spectrum detention pond, and utilities as normally constructed for a residential development.

## ***Existing Site Conditions***

The Homestead at Sterling Ranch Filing No. 2 site consists of 29.658 acres and is situated west of the Sand Creek Watershed. This area was previously studied in the "Sand Creek Drainage Basin Planning Study" (DBPS) prepared by Kiowa Corporation, revised March 1996. More recently the area was studied in the "Master Development Drainage Report for Sterling Ranch Filing Nos. 1&2, and Final Drainage Report for Sterling Ranch Filing No.1" prepared by MS Civil Consultants, dated April 2017 (henceforth referred to as "Sterling Ranch Filing Nos. 1&2 MDDP"). Homestead at Sterling Ranch Filing No. 2 and the surrounding areas, with the exception of the existing Barbarick Subdivision, have already been graded during the overlot of the subdivision. Please refer to the Sterling Ranch Filing Nos. 1&2 MDDP by MS Civil Consultants for information on historic conditions and overlot drainage patterns.

## ***Soils***

Soils for this project are delineated by the map in the appendix as Pring Coarse Sandy Loam (71) and is characterized as Hydrologic Soil Types "B". Soils in the study area are shown as mapped by S.C.S. in the "Soils Survey of El Paso County Area". Vegetation is sparse, consisting of native grasses and weeds.

## Soil Erosion Potential

The proposed onsite construction activities anticipate the potential for soil erosion. Onsite stormwater BMP management facilities are proposed to minimize and aid in soil erosion. Group B soils have a moderate infiltration rate when thoroughly wet. These consist chiefly of moderate deep or deep, moderately well drained or well drained soils that have moderately fine texture to moderately coarse texture. These soils have a moderate rate of water transmission. These soils thus have a moderate potential for erosion. The existing vegetation is sparse, consisting of prairie grasses and shrubs. The percent of ground cover for this project is 100% prairie grasses and shrubs. A post construction comparison can be made from the adjacent undeveloped property.



based on... (visual observation?)

## Phasing Plan

*Homestead at Sterling Ranch Filing No. 2 is not a phased project. The entire development will be constructed in the normal sequence of a single family development.*



## Water Quality

The proposed temporary Full Spectrum Detention Facility, Interim Pond 1 functions as a water quality facility for runoff produced onsite from tributary Basins T, U, V1, V2 and W3. This water quality facility is designed to treat 0.245 ac-ft of water quality storage (WQCV), 0.741 ac-feet of excess urban runoff volume (EURV) and 1.331 ac-ft of 100-year storage. An emergency spillway, riprap stilling basin and trickle channel, outlet structure, and maintenance access road has been designed for Interim Pond 1.

Runoff produced within the residential backyard lots, of Basins X1, X2, W1 and Y1 will be conveyed in backyard swales and as sheet flow to a Sand Filter Basin within each lot. The treated flows will be collected by private storm sewer systems and discharged into the Sand Creek Channel. This water quality facility, for each Sand Filter Basin, is designed to treat 0.001 ac-ft of water quality storage (WQCV), 0.005 ac-feet of excess urban runoff volume (EURV) and 0.014 ac-ft of 100-year storage. A 20' wide typical drainage easement is provided within the lots to accommodate the BMP's. The facilities constructed are to be privately maintained by the Sterling Ranch metro district.

The pond 1 is temporary in nature and designed to provide water quality during the interim period before ultimate channel improvements to Sand Creek have been completed. Upon ultimate channel improvements to Sand Creek, the pond shall be removed and runoff shall be routed south, via the proposed 36" RCP pipe extending from the proposed modified 5'x4.5' CDOT Type R sump inlet. A drainage easement will be provided to route the 36" RCP to a permanent FSD facility for treatment.

Delete. Revisions can be made with a future SWMP.

### ***Narrative Description of BMP Control Measures***

Installations of BMPs are staged in order to minimize the potential for pollutants in the stormwater discharge. The following stages will be used: establishment of perimeter controls, installation of temporary BMPs during soil disturbance and then finally installation of permanent controls. Descriptions of some of the available BMPs are listed in below stages:

Only clearing necessary for the installation of perimeter controls should be employed in the first stage of temporary BMPs installation. Silt fence and vehicle tracking should be installed as shown on the Grading & Erosion Control Plan. At this time, the El Paso County inspector should be notified to schedule an initial inspection. Rough grading of the site will precede construction of proposed underground utilities.

Once utilities and storm drain infrastructure have been constructed, installation of temporary BMPs will commence. Temporary BMPs for this site consist of Inlet Protection. Locations for a concrete washout area and temporary stockpile location will also be established. These locations are likely to be different than what is shown on the Grading and Erosion Control Plan that accompanies this report. Once these locations have been established, they should be added and denoted on the copy of the plan that will be kept with the site administrator.

The final stage is the installation of permanent BMPs where no further disturbance is anticipated. Upon completion of the permanent BMPs and all grading activities are completed, all disturbed areas not sodded or developed will be mulched and reseeded with native seed mix and may be watered until vegetative cover has been fully re-instated. At this point, the person responsible for inspection and maintenance can begin to address requirements for final stabilization. See construction details for installation and maintenance.

**Specifically, the proposed project will use silt fence, a vehicle tracking control pad, concrete washout area, inlet protection, mulching and reseeded to mitigate the potential for erosion across the site.**

No ground water, springs, or irrigation of non-stormwater discharge covered by CDPHE low risk guidance are known for this project. ✓

No additional areas for storage of building materials, soil stockpiles or wastes are proposed for this project. The existing equipment storage yard for Sterling Ranch contractors will be utilized. Access for the project for construction equipment will be along the construction corridor. Construction vehicles (trucks) will access the site from adjacent public roadways.

There are no dedicated asphalt or concrete batch plants associated with this project.

This project does not rely on control measures owned or operated by another entity. There are no offsite stormwater control measures proposed for use by the project that are not under the direct control of the owner or contractor.

### ***Timing Schedule***

Anticipated Starting and Completion Time Period of Grading Activities:

**April 2019 - October 2022**

Expected Date on Which The Final Stabilization Will Be Completed:

**December 2022**

**Areas of Disturbance**

Total subject property site acreage: **29.658 AC**

Total disturbed area of subject property: **29.658 AC**



**Permanent Stabilization**

Final stabilization is reached when all soil-disturbing activities at the site have been completed, and uniform vegetative cover has been established by drill seeding and crimping with a density of at least 70% of pre-disturbance levels or equivalent permanent physical erosion reduction methods have been employed. The CDPHE Water Quality Division may, after consultation with the permittee and upon good cause, amend the final stabilization criteria for specific operations. At this time, the El Paso County inspector should be notified to schedule a final inspection. The conditions of the SWMP and General Permit for Stormwater Discharges associated with Construction Activity will remain in effect until Final Stabilization is achieved and a notice of inactivation is sent by the applicant to CDPHE Stormwater Quality Division. All pertinent records must be kept on file for at least 3 years from the date the site is finally stabilized.



**Owner Inspections and Maintenance of BMP's**



1. Make thorough inspection of the stormwater management system at least every 14 days.
2. Make thorough inspection of the stormwater management system after each precipitation event that causes runoff.
3. If any deficiencies are noted, they must be corrected immediately after being noted.
4. Records of the site inspections or modifications must be kept at the site unless alternate place is approved by the El Paso County inspector and must be made available upon request.
5. Inspections must take place where construction activity is complete, but lot is not sold.
6. Monthly inspections must take place on site where construction activity is complete, but vegetative cover is still being established.

**Soil Borings I Test and Groundwater**

A Geotechnical Investigation has been completed for the overall Sterling Ranch development which is inclusive of Homestead at Sterling Ranch Filing No.2 site, titled Geologic Hazard Evaluation Sterling Ranch Residential, EL Paso County Colorado, by CTL Thompson Inc. dated January 20, 2009.

**Site Run-Off Characteristics**

The site runoff coefficients are:	Minor Storm	Major Storm
-Historic existing Conditions	0.09	0.36
-Roofs, sidewalks, paved areas	0.90	0.96
-Landscaped and undeveloped areas	0.25	0.35

# STORMWATER MANAGEMENT PLAN

## ***Introduction***

**To: Site Inspector responsible for all Colorado Department of Public Health and Environment and El Paso County**

### **Requirements:**

The following stormwater management plan (SWMP) is a required item under the Construction Stormwater Discharge Permit. The primary goal for a SWMP is to improve water quality by reducing pollutants in stormwater discharges. Construction dewatering is a separate issue, and must be covered by the CDPHE Stormwater Quality Division's general permit for construction dewatering (regardless of the size of the construction project). Stormwater that mixes with ground water in an excavation is subject to the controls of a Construction Dewatering Permit. It is assumed that the SWMP will be completed and implemented at the time the project breaks ground, and will be revised if necessary as construction proceeds. This document must be kept at the construction site at all times and be made available to the public and any representative of any Water Quality Control Divisions if requested. Inspection guidance can be found at [www.cdphe.state.co.us](http://www.cdphe.state.co.us) and El Paso County and City of Colorado Springs Storm Drainage Design Criteria. The inspections should be made at least every 14 days and after any precipitation or snowmelt event that causes surface erosion. El Paso County requires that the inspector must be contacted 48 hours prior to initial and final inspections. An inspection log entry should be completed with each inspection performed. The inspection log should be kept with the SWMP. The conditions of the SWMP and General Permit for Stormwater Discharges associated with the construction activity will remain in effect until final stabilization is achieved, and a notice of inactivation is sent to CDPHE Stormwater Quality Division. All pertinent records must be kept for at least 3 years from date the site is stabilized or sold.

## ***Floodplain Statement***

No portion of this site lies within a designated F.E.M.A. floodplain as determined by the Federal Emergency Management Agency (FEMA) Flood Insurance Rate Map (FIRM) Panel No. 08041C0535 G, effective date December 7, 2018 and revised to reflect LOMR, 08-08-O541P, dated July 23, 2009. An annotated FIRM Panel is included in the Appendix.

## ***Receiving Water Description***

The site is located with the greater Sand Creek Drainage Basin. No stream crossings are proposed for this project. Bank Stabilization will occur adjacent to the site along Sand Creek. The channel improvement plans for Sand Creek will be provided under a separate project by Kiowa Engineering.

If the same SWMP is being used for channel bank stabilization this should be corrected.

### ***Existing Vegetation Description***

Homestead at Sterling Ranch Filing No. 2 consists of 29.658 acres and is presently undeveloped. Vegetation is sparse, consisting of native grasses. Existing site terrain generally slopes from north to southwest at grade rates that vary between 2% and 6%. Land use for Homestead at Sterling Ranch Filing No. 2 is currently listed as AG (Grazing Land).

### ***Potential Pollution Sources***

Construction activities that will take place at this site may have an impact on the stormwater quality. These include, but are not limited to, portable toilets, materials storage, vehicle fueling, maintenance and vehicle tracking, dust, waste piles and dumpsters. The location of any of these activities not included on the initial site map should be added along with a description of the measures used to prevent the discharge of these materials from the site. See construction details for installation and maintenance. All trash and debris should be removed from the site on a regular basis and disposed of properly.

### ***Anticipated Non-Stormwater Discharges***

Non-stormwater discharges are caused by activities other than direct runoff from precipitation events. These include, but are not limited to natural springs, irrigation. Any non-stormwater discharges that are not included in the initial map should be added along with a description of measures used to handle it. There are no known natural springs, temporary or permanent irrigation that would cause erosion on this project site. ✓

## **EROSION SEDIMENT CONTROLS**

### ***Proposed Sequence of Construction Activities***

1. Notify the inspector for initial inspection.
2. Clearing for necessary for perimeter controls.
3. Construct vehicle traffic control pad at entrance/exit of construction site.
4. Install lot perimeter controls, including silt fence, delineating project site as indicated on Site Map.
5. Complete remaining clearing and grubbing for project area. Install additional BMPs, as indicated on Site Map.
6. Final grade site as indicated on Site Map.
7. Achieve Final Stabilization, as outlined in SWMP. Send inactivation notice to CDPHE.
8. See Construction Details for BMP Installation and Maintenance.

Any stockpile areas are to be contained with silt fence, or other acceptable measures to prevent erosion and sediment from leaving the area. All BMP's that may be in place need to be inspected and cleaned if sediment should leave the site and enter the streets. Erosion control measures shall be implemented in a manner that will protect properties and public facilities from the adverse effect of erosion and

sedimentation as a result of construction and earthwork activities. The following practices are to be implemented for this site:

### ***Structural Practices***

In areas of sheet flow running off-site and at the top and bottom of steep slopes, silt fence will be used to trap sediment. Silt fence should be placed on the contour and in areas where the tributary area is less than one-quarter acre per 100' of silt fence. A vehicle traffic control pad will be installed at the entrance/exit of the site to reduce sediment tracking off-site.

Practices may include, but are not limited to straw bales, wattles/sediment control logs, silt fences, earth dikes, drainage swales, sediment traps, subsurface drains, pipe slope drains, inlet protection, outlet protection, gabions, and temporary or permanent sediment basins. All roads will be inspected to ensure that sediment from on-site construction activity is not being discharged with the stormwater. Sediment and debris that have been tracked off-site should be removed daily by shoveling or sweeping. See construction details for installation and maintenance.

### ***Non-Structural Practices***

Surface roughening may be used to reduce the amount of runoff and wind erosion from any given areas. Once the existing vegetation is cleared, watering should occur to help control fugitive dust. Disturbed areas where work is temporarily halted shall be temporarily stabilized within 21 calendar days after activity has ceased unless work is to be resumed within 30 calendar days after the activity has ceased. Other Non-Structural Practices may include soils erosion control measures for all slopes, channels, ditches, or any disturbed land area shall be completed within 21 calendar days after final grade, or final earth disturbance, has been completed. Disturbed areas and stockpiles, which are not at final grade but will remain dormant for longer than 30 days, shall also be mulched within 21 days after interim grading. An area that is going to remain in an interim state for more than 60 days shall also be seeded. All temporary soil erosion control measures and BMPs shall be maintained until permanent soil erosion control measures are implemented. See construction details for installation and maintenance.

### ***Materials Handling and Spill Practices***

Any substances with potential to contaminate either the ground or ground surface water shall be cleaned up immediately after discovery or contained until appropriate cleanup methods can be employed. Manufacturer's recommended methods for clean up shall be followed, along with proper disposal methods. Any discharge of hazardous materials must be handled in accordance with the Divisions Notification Requirement. All waste and debris created by construction activities at the site or removed from the site shall be disposed of in compliance with all laws, regulations and ordinances of the federal, state and local agencies. See construction details for Materials Handling and Spills. ✓

### ***Potential Pollution Sources***

Construction activities that will take place at this site may have an impact on the stormwater quality. These include, but are not limited to, portable toilets, materials storage, vehicle fueling, maintenance and vehicle tracking, dust, waste piles and dumpsters. The



location of any of these activities not included on the initial site map should be added along with a description of the measures used to prevent the discharge of these materials from the site. See construction details for installation and maintenance.

### ***Selecting Post-Construction BMPs***

Post Construction BMPs; Rock and revegetation including seeding, mulching and erosion control blanket will be the final BMP's. Permanent stabilization will be achieved with 70% vegetative establishment.

### **Inspections**

Inspections should occur at least every 14 days and within 24 hours of a rainfall event producing runoff, usually this occurs with precipitation of 1/4 inch of rain or more. The local news weather report gives general rainfall amounts each day.

The inspection schedule should be routinely accomplished every 14 days and within 24 hours of the end of a storm event for the entire site with all BMP's evaluated for performance and need. Any BMP found to be ineffective should be re-accomplished or replaced with a new BMP to provide the level of protection needed. BMP's found to be no longer needed can be removed. Inspections should also be accomplished as soon as practical, at the end of a rain event causing surface erosion. The general procedure for correcting problems when identified should be documented in a log and a solution to correct the problem as soon as possible.

### **Record Keeping**

Records should be retained for a minimum period of at least 3 years after the permit is terminated. Use log sheet provided in the Appendix of this report. The inspection logs and location of SWMP records should be kept onsite.

## APPENDICES

COPY OF CDPHE APPLICATION



# COLORADO

Department of Public Health & Environment

Dedicated to protecting and improving the health and environment of the people of Colorado

ASSIGNED PERMIT NUMBER

Date Received \_\_\_\_/\_\_\_\_/\_\_\_\_  
MM DD YYYY  
Revised: 10-2017

## STORMWATER DISCHARGE ASSOCIATED WITH CONSTRUCTION ACTIVITIES APPLICATION COLORADO DISCHARGE PERMIT SYSTEM (CDPS)

**PHOTO COPIES, FAXED COPIES, PDF COPIES OR EMAILS WILL NOT BE ACCEPTED.**

**For Applications submitted on paper - Please print or type. Original signatures are required.**

All items must be completed accurately and in their entirety for the application to be deemed complete. Incomplete applications will not be processed until all information is received which will ultimately delay the issuance of a permit. If more space is required to answer any question, please attach additional sheets to the application form. Applications or signature pages for the application may be submitted by mail or hand delivered to:

Colorado Department of Public Health and Environment, 4300 Cherry Creek Drive South, WQCD-P-B2, Denver, CO 80246-1530

**For Applications submitted electronically**

Please note that you can ONLY complete the feedback form by downloading it to a PC or Mac/Apple computer and opening the Application with Adobe Reader or a similar PDF reader. The form will NOT work with web browsers, Google preview, Mac preview software or on mobile devices using iOS or Android operating systems.

If application is submitted electronically, processing of the application will begin at that time and not be delayed for receipt of the signed document.

Any additional information that you would like the Division to consider in developing the permit should be provided with the application. Examples include effluent data and/or modeling and planned pollutant removal strategies.

**Beginning July 1, 2016, invoices will be based on acres disturbed.**

**DO NOT PAY THE FEES NOW - Invoices will be sent after the receipt of the application.**

Disturbed Acreage for this application (see page 4)

- Less than 1 acre (\$83 initial fee, \$165 annual fee)
- 1-30 acres (\$175 initial fee, \$350 annual fee)
- Greater than 30 acres (\$270 initial fee, \$540 annual fee)

### PERMIT INFORMATION

Reason for Application:  NEW CERT  RENEW CERT EXISTING CERT# \_\_\_\_\_

Applicant is:  Property Owner  Contractor/Operator

### A. CONTACT INFORMATION - \*indicates required

\* PERMITTED ORGANIZATION FORMAL NAME: SR Land, LLC

1) \* PERMIT OPERATOR - the party that has operational control over day to day activities - may be the same as owner.

Responsible Person (Title): Project Manager

Currently Held By (Person): FirstName: Chaz LastName: Collins

Telephone: 719-491-8717 Email Address: candclandllc@aol.com

Organization: SR Land, LLC

Mailing Address: 20 Boulder Crescent

City: Colorado Springs State: CO Zip Code: 80903

**Per Regulation 61** : All reports required by permits, and other information requested by the Division shall be signed by the permittee or by a duly authorized representative of that person. A person is a duly authorized representative only if:

- (i) The authorization is made in writing by the permittee
- (ii) The authorization specifies either an individual or a position having responsibility for the overall operation of the regulated facility or activity such as the position of plant manager, operator of a well or a well field, superintendent, position of equivalent responsibility, or an individual or position having overall responsibility for environmental matters for the company. (A duly authorized representative may thus be either a named individual or any individual occupying a named position); and
- (iii) The written authorization is submitted to the Division

2) **OWNER - party has ownership or long term lease of property - may be the same as the operator.**

Same as 1) Permit Operator

Responsible Person (Title): Project Manager  
Currently Held By (Person): First Name: Chaz Last Name: Collins  
Telephone: 719-491-8717 Email Address: candclandllc@aol.com  
Organization: SR Land, LLC  
Mailing Address: 20 Boulder Crescent  
City: Colorado Springs State: CO Zip Code: 80903

**Per Regulation 61** : All reports required by permits, and other information requested by the Division shall be signed by the permittee or by a duly authorized representative of that person. A person is a duly authorized representative only if:

- i. The authorization is made in writing by the permittee.
- ii. The authorization specifies either an individual or a position having responsibility for the overall operation of the regulated facility or activity such as the position of plant manager, operator of a well or a well field, superintendent, position of equivalent responsibility, or an individual or position having overall responsibility for environmental matters for the company. (A duly authorized representative may thus be either a **named individual** or any individual occupying a **named position**); and
- iii. The written authorization is submitted to the Division.

3) **\*SITE CONTACT** local contact for questions relating to the facility & discharge authorized by this permit for the facility

Same as 1) Permit Operator

Responsible Person (Title): Project Manager  
Currently Held By (Person): First Name: Chaz Last Name: Collins  
Telephone: 719-491-8717 Email Address: candclandllc@aol.com  
Organization: SR Land, LLC  
Mailing Address: 20 Boulder Crescent  
City: Colorado Springs State: CO Zip Code: 80903

4) **\*BILLING CONTACT** if different than the permittee.

Same as 1) Permit Operator

Responsible Person (Title): Project Manager  
Currently Held By (Person): First Name: Chaz Last Name: Collins  
Telephone: 719-491-8717 Email Address: candclandllc@aol.com  
Organization: SR Land, LLC  
Mailing Address: 20 Boulder Crescent  
City: Colorado Springs State: CO Zip Code: 80903

5) **OTHER CONTACT TYPES (check below) Add pages if necessary:**

Responsible Person (Title): \_\_\_\_\_  
Currently Held By (Person): First Name: \_\_\_\_\_ Last Name: \_\_\_\_\_  
Telephone: \_\_\_\_\_ Email Address: \_\_\_\_\_  
Organization: \_\_\_\_\_  
Mailing Address: \_\_\_\_\_  
City: \_\_\_\_\_ State: \_\_\_\_\_ Zip Code: \_\_\_\_\_

- |  |   |   |
|--|---|---|
| <input type="checkbox"/> Environmental Contact       | <input type="checkbox"/> Consultant         | <input type="checkbox"/> Stormwater MS4 Responsible Person    |
| <input type="checkbox"/> Inspection Facility Contact | <input type="checkbox"/> Compliance Contact | <input type="checkbox"/> Stormwater Authorized Representative |

**B) PERMITTED PROJECT/FACILITY INFORMATION**

Project/Facility Name Homestead at Sterling Ranch Fil. No. 2  
Street Address or Cross Streets S and E of the INtersection of Vollmer Rd and Dines Blvd  
(e.g., Park St and 5 Ave; CR 21 and Hwy 10; 44 Ave and Clear Creek) ; A street name without an address, intersection, mile marker, or other identifying information describing the location of the project is not adequate. For **linear projects**, the route of the project should be described as best as possible using the starting point for the address and latitude and longitude - more clearly defined in the required map )

City: Colorado Springs County: El Paso Zip Code: 80908

**Facility Latitude/Longitude** - List the latitude and longitude of the excavation(s) resulting in the discharge(s). If the exact soil disturbing location(s) are not known, list the latitude and longitude of the center point of the construction project. If using the center point, be sure to specify that it is the center point of construction activity. The preferred method is GPS and Decimal Degrees.

Latitude 38 . 96614 Longitude 104 . 67043 (e.g., 39.70312°, 104.93348°)  
Decimal Degrees (to 5 decimal places) Decimal Degrees (to 5 decimal places)

This information may be obtained from a variety of sources, including:

- **Surveyors or engineers** for the project should have, or be able to calculate, this information.
- **U.S. Geological Survey topographical map(s)**, available at area map stores.
- Using a **Global Positioning System (GPS) unit** to obtain a direct reading.
- **Google** - enter address in search engine, select the map, right click on location, and select "what's here".

*Note: the latitude/longitude required above is not the directional degrees, minutes, and seconds provided on a site legal description to define property boundaries.*

**C) MAP (Attachment) If no map is submitted, the application cannot be submitted.**

**Map:** Attach a map that indicates the site location and that CLEARLY shows the boundaries of the area that will be disturbed. A vicinity map is not adequate for this purpose.

**D) LEGAL DESCRIPTION - only for Subdivisions**

**Legal description:** If subdivided, provide the legal description below, or indicate that it is not applicable (**do not** supply Township/Range/Section or metes and bounds description of site)

Subdivision(s): TR E of SR Fil. No. 1 Lot(s): \_\_\_\_\_ Block(s) \_\_\_\_\_

OR  Not applicable (site has not been subdivided)

**E) AREA OF CONSTRUCTION SITE - SEE PAGE 1 - WILL DETERMINE FEE**

Provide both the total area of the construction site, and the area that will undergo disturbance, in acres.

Total area of project disturbance site (acres): 29.658 AC

**Note:** aside from clearing, grading and excavation activities, disturbed areas also include areas receiving overburden (e.g., stockpiles), demolition areas, and areas with heavy equipment/vehicle traffic and storage that disturb existing vegetative cover.

Part of Larger Common Plan of Development or Sale, (i.e., total, including all phases, filings, lots, and infrastructure not covered by this application)

**F) NATURE OF CONSTRUCTION ACTIVITY**

Check the appropriate box(es) or provide a brief description that indicates the general nature of the construction activities. (The full description of activities must be included in the Stormwater Management Plan.)

- Commercial Development
- Residential Development
- Highway and Transportation Development
- Pipeline and Utilities (including natural gas, electricity, water, and communications)
- Oil and Gas Exploration and Well Pad Development
- Non-structural and other development (i.e. parks, trails, stream realignment, bank stabilization, demolition, etc.)

**G) ANTICIPATED CONSTRUCTION SCHEDULE**

Construction Start Date: APR 2019 Final Stabilization Date: Dec 2022

- *Construction Start Date* - This is the day you expect to begin ground disturbing activities, including grubbing, stockpiling, excavating, demolition, and grading activities.
- *Final Stabilization Date* - in terms of permit coverage, this is when the site is finally stabilized. This means that all ground surface disturbing activities at the site have been completed, and all disturbed areas have been either built on, paved, or a uniform vegetative cover has been established with an individual plant density of at least 70 percent of pre-disturbance levels. **Permit coverage must be maintained until the site is finally stabilized. Even if you are only doing one part of the project, the estimated final stabilization date must be for the overall project.** If permit coverage is still required once your part is completed, the permit certification may be transferred or reassigned to a new responsible entity(s).

**H) RECEIVING WATERS (If discharge is to a ditch or storm sewer, include the name of the ultimate receiving waters)**

Immediate Receiving Water(s): Sand Creek

Ultimate Receiving Water(s): Sand Creek

Identify the receiving water of the stormwater from your site. Receiving waters are any waters of the State of Colorado. This includes all water courses, even if they are usually dry. If stormwater from the construction site enters a ditch or storm sewer system, identify that system and indicate the ultimate receiving water for the ditch or storm sewer. **Note:** a stormwater discharge permit does not allow a discharge into a ditch or storm sewer system without the approval of the owner/operator of that system.

**I) SIGNATURE PAGE**

1. You may print and sign this document and mail the hard copy to the State along with required documents (address on page one).

**2. Electronic Submission Signature**

You may choose to submit your application electronically, along with required attachments. To do so, click the SUBMIT button below which will direct you, via e-mail, to sign the document electronically using the DocuSign Electronic Signature process. Once complete, you will receive via e-mail, an electronically stamped Adobe pdf of this application. Print the signature page from the electronically stamped pdf, sign it and mail it to the WQCD Permits Section to complete the application process (address is on page one of the application).

- The Division encourages use of the electronic submission of the application and electronic signature. This method meets signature requirements as required by the State of Colorado.
- The ink signed copy of the electronically stamped pdf signature page is also required to meet Federal EPA Requirements.
- Processing of the application will begin with the receipt of the valid electronic signature.

**STORMWATER MANAGEMENT PLAN CERTIFICATION**

By checking this box "I certify under penalty of law that a complete Stormwater Management Plan, as described in the stormwater management plan guidance, has been pre-pared for my activity. Based on my inquiry of the person or persons who manage the system, or those persons directly responsible for gathering the information, the Stormwater Management Plan is, to the best of my knowledge and belief, true, accurate, and complete. I am aware that there are significant penalties for falsely certifying the completion of said SWMP, including the possibility of fine and imprisonment for knowing violations."

"I certify under penalty of law that this document and all attachments were prepared under my direction or supervision in accordance with a system designed to assure that qualified personnel properly gather and evaluate the information submitted. Based on my inquiry of the person or persons who manage the system, or those persons directly responsible for gathering the information, the information submitted is to the best of my knowledge and belief, true, accurate and complete. I am aware that there are significant penalties for submitting false information, including the possibility of fine and imprisonment for knowing violations."

"I understand that submittal of this application is for coverage under the State of Colorado General Permit for Stormwater Discharges Associated with Construction Activity for the entirety of the construction site/project described and applied for, until such time as the application is amended or the certification is transferred, inactivated, or expired." [Reg 61.4(1)(h)]

For DocuSign  
Electronic Signature \_\_\_\_\_ Ink Signature \_\_\_\_\_ Date: \_\_\_\_\_

Signature of Legally Responsible Person or Authorized Agent (submission must include original signature)

Chaz Collins

Project Manager

Name (printed)

Title

**Signature:** The applicant must be either the owner and operator of the construction site. Refer to Part B of the instructions for additional information.

The application must be signed by the applicant to be considered complete. In all cases, it shall be signed as follows:  
(Regulation 61.4 (1e))

- In the case of corporations, by the responsible corporate officer is responsible for the overall operation of the facility from which the discharge described in the form originates
- In the case of a partnership, by a general partner.
- In the case of a sole proprietorship, by the proprietor.
- In the case of a municipal, state, or other public facility, by either a principal executive officer, ranking elected official, (a principal executive officer has responsibility for the overall operation of the facility from which the discharge originates).

**3rd Party Preparer:** If this form was prepared by an authorized agent on behalf of the Permittee, please complete the field below.

Preparer Name (printed) \_\_\_\_\_ Email Address \_\_\_\_\_

**DO NOT INCLUDE A COPY OF THE STORMWATER MANAGEMENT PLAN  
DO NOT INCLUDE PAYMENT—AN INVOICE WILL BE SENT AFTER THE CERTIFICATION IS ISSUED.**

<input type="text"/>	<b>Attach Map</b>
<input type="text"/>	<b>Attach File</b>
<input type="text"/>	<b>Attach File</b>
<input type="text"/>	<b>Attach File</b>
<input type="text"/>	<b>Attach File</b>



VICINITY MAP

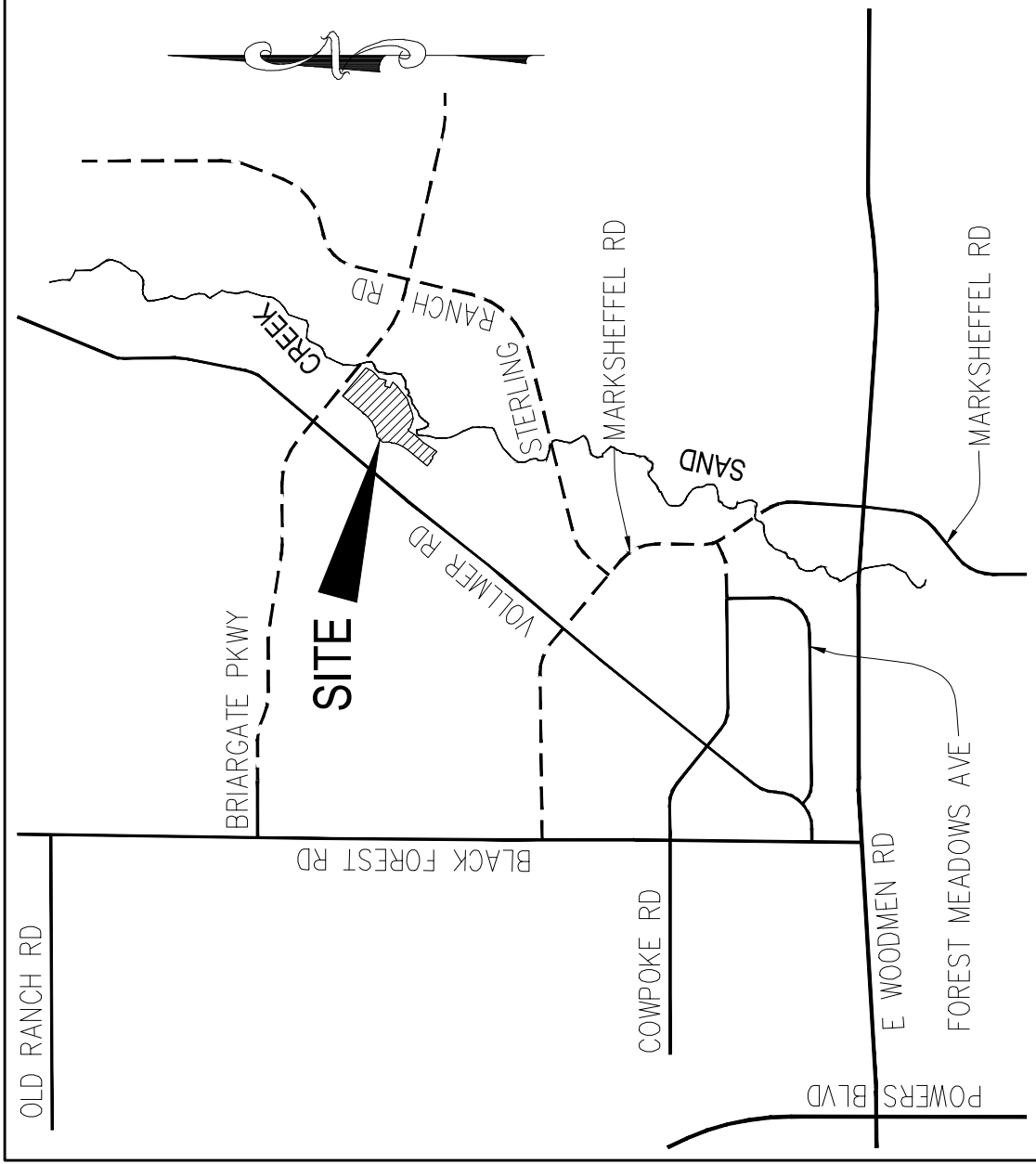

# VICINITY MAP ✓

N.T.S.

GRADING, EROSION, STORMWATER  
INSPECTION CHECKLIST

# Appendix C Inspection Checklist – Grading Erosion, and Stormwater Quality Controls



DATE/TIME:
INSPECTOR:
TYPE OF INSPECTION: Self-Monitoring____ Initial ____ Compliance____ Follow-Up____ Reconnaissance____ Complaint____ Final____

SITE:	DATE OF PERMIT:
ADDRESS:	
CONTRACTOR: CONTACT: PHONE:	OWNER/OWNER'S REPRESENTATIVE: CONTACT: PHONE:
STAGE OF CONSTRUCTION: Initial BMP Installation/Prior to Construction____ Clearing & Grubbing____ Rough Grading____ Finish Grading____ Utility Construction____ Building Construction____ Final Stabilization____	

OVERALL SITE INSPECTION	YES/NO/N.A.	REMARKS/ACTIONS
Is there any evidence of sediment leaving the construction site? If so, note areas.		
Have any adverse impacts such as flooding, structural damage, erosion, spillage, or accumulation of sediment, debris or litter occurred on or within public or private property, wetlands or surface waters –to include intermittent drainageways and the City's stormwater system (storm sewers, gutters, ditches, etc.)?		
Are the BMPs properly installed and maintained?		
Have the BMPs been placed as shown on approved plans?		
Are the BMPs functioning as intended?		
Is work being done according to approved plans and any phased construction schedule?		
Is the construction schedule on track?		
Are drainage channels and outlets adequately stabilized?		
Is there any evidence of discharges or spills of fuels, lubricants, chemicals, etc.?		

<b>BMP MAINTENANCE CHECKLIST</b>	<b>YES/NO/N.A.</b>	<b>REMARKS/ACTIONS NECESSARY</b>
<p><b>SURFACE ROUGHENING</b></p> <p>Is the roughening consistent/uniform on slopes??</p> <p>Any evidence of erosion?</p>		
<p><b>TEMPORARY SEEDING</b></p> <p>Are the seedbeds protected by mulch?</p> <p>Has any erosion occurred in the seeded area?</p> <p>Any evidence of vehicle tracking on seeded areas?</p>		
<p><b>TEMPORARY SWALES</b></p> <p>Has any sediment or debris been deposited within the swales?</p> <p>Have the slopes of the swale eroded or has damage occurred to the lining?</p> <p>Are the swales properly located?</p>		
<p><b>VEHICLE TRACKING</b></p> <p>Is gravel surface clogged with mud or sediment?</p> <p>Is the gravel surface sinking into the ground?</p> <p>Has sediment been tracked onto any roads and has it been cleaned up?</p> <p>Is inlet protection placed around curb inlets near construction entrance?</p>		
<p><b>OTHER</b></p>		

FINAL INSPECTION CHECKLIST	YES/NO/N.A.	REMARKS/ACTIONS NECESSARY
Has all grading been completed in compliance with the approved Plan, and all stabilization completed, including vegetation, retaining walls or other approved measures?		
Has final stabilization been achieved – uniform vegetative cover with a density of at least 70 percent of pre-disturbance levels, and cover capable of adequately controlling soil erosion; or permanent, physical erosion methods?		
Have all temporary measures been removed?		
Have all stockpiles, construction materials and construction equipment been removed?		
Are all paved surfaces clean (on-site and off-site)?		
Has sediment and debris been removed from drainage facilities (on-site and off-site) and other off-site property, including proper restoration of any damaged property?		
Have all permanent stormwater quality BMPs been installed and completed?		

ADDITIONAL COMMENTS:

The items noted as needing action must be remedied no later than \_\_\_\_\_.  
The contractor shall notify the inspector when all the items noted above have been addressed.

By signing this inspection form, the owner/owner’s representative and the contractor acknowledge that they have received a copy of the inspection report and are aware it is their responsibility to take corrective actions by the date noted above. Failure to sign does not relieve the contractor and owner/owner’s representative of their responsibility to take the necessary corrective action and of their liability for any damages that have occurred or may occur.

INSPECTOR’S SIGNATURE:	DATE:
OWNER/OWNER’S REPRESENTATIVE SIGNATURE:	DATE:
CONTRACTOR’S SIGNATURE:	DATE:

**SPILL CLEANUP INSTRUCTIONS AND REPORT FORM**

involving a radioactive or infectious material, or there is a release of a marine pollutant.

Spills and incidents that have or may result in a spill along a highway must be reported to the nearest law enforcement agency immediately. The Colorado State Patrol and CDPHE must also be notified as soon as possible. In the event of a spill of hazardous waste at a transfer facility, the transporter must notify CDPHE within 24 hours if the spill exceeds 55 gallons or if there is a fire or explosion.

The National Response Center should be notified as soon as possible after discovery of a release of a hazardous liquid or carbon dioxide from a pipeline system if a person is killed or injured, there is a fire or explosion, there is property damage of \$50,000 or more, or any nearby water body is contaminated.

The National Response Center and the Colorado Public Utilities Commission Gas Pipeline Safety Section must be notified as soon as possible, but not more than two hours after discovery of a release of gas from a natural gas pipeline or liquefied natural gas facility if a person is killed or injured, there is an emergency shutdown of the facility, or there is property damage of \$50,000 or more. The Colorado Public Utilities Commission should also be notified if there is a gas leak from a pipeline, liquefied natural gas system, master meter system or a propane system that results in the evacuation of 50 or more people from an occupied building or the closure of a roadway.

### **Oil and Gas Exploration**

All Class I major events on federal lands, including releases of hazardous substances in excess of the CERCLA reportable quantity and spills of more than 100 barrels of fluid and/or 500 MCF of gas released, must be reported to the Bureau of Land Management (BLM) immediately. Spills of oil, gas, salt water, toxic liquids and waste materials must also be reported to the BLM and the surface management agency.

Spills of exploration and production (E&P) waste on state or private lands in excess of 20 barrels, and spills of any size that impact or threaten to impact waters of the state, an occupied structure, or public byway must be reported to the Colorado Oil and Gas Conservation Commission as soon as practicable, but not more than 24 hours after discovery. Spills of any

size that impact or threaten to impact waters of the state must be reported to CDPHE immediately. Spills that impact or threaten to impact a surface water intake must be reported to the emergency contact for that facility immediately after discovery. Spills of more than five (5) barrels of E&P waste must be reported in writing to the Oil and Gas Conservation Commission within 10 days of discovery.

### **REPORTING NUMBERS**

National Response Center (24-hour)  
**1-800-424-8802**

CDPHE Colorado Environmental Release and Incident Reporting Line (24-hour)  
**1-877-518-5608**

Radiation Incident Reporting Line (24-hour)  
**303-877-9757**

Colorado State Patrol (24-hour)  
**303-239-4501**

Division of Oil and Public Safety  
(business hours)  
**303-318-8547**

Oil and Gas Conservation Commission  
(business hours)  
**303-894-2100**

Colorado Public Utilities Commission Gas Pipeline Safety Section (business hours)  
**303-894-2851**

Local Emergency Planning Committees  
(to obtain list, business hours)  
**720-852-6603**



Colorado Department  
of Public Health  
and Environment

# **Environmental Spill Reporting**

Colorado Department of Public  
Health and Environment  
4300 Cherry Creek Drive South  
Denver, CO 80246-1530

<http://www.cdph.state.co.us>

January 2009

When a release of a hazardous material or other substance occurs to the environment, there are a number of reporting and notification requirements that must be followed by the company or individual responsible for the release. Most spills are covered by more than one reporting requirement, and **all** requirements must be met. In addition to verbal notification, written reports are generally required. This brochure briefly explains the major requirements. A more detailed description is provided in the "Reporting Environmental Releases in Colorado" Guidance Document, available on the web.

Releases that must be reported to the Colorado Department of Public Health and Environment (CDPHE) may be reported to the Colorado Environmental Release and Incident Reporting Line.



## ENVIRONMENTAL SPILL REPORTING

### CERCLA, EPCRA and RCRA

The Comprehensive Environmental Response, Compensation and Liability Act (CERCLA) and the Emergency Planning and Community Right-to-Know Act (EPCRA) require that a release of a reportable quantity or more of a hazardous substance to the environment be reported immediately to the appropriate authorities when the release is discovered.

Under CERCLA, reportable quantities were established for hazardous substances listed or designated under other environmental statutes. These include:

- all hazardous air pollutants (HAPs) listed under Section 112(b) of the Clean Air Act.
- all toxic pollutants designated under Section 307(a) or Section 311(b)(2)(A) of the Clean Water Act.
- all Resource Conservation and Recovery Act (RCRA) characteristic and listed hazardous wastes.
- any element, compound, or substance designated under Section 102 of CERCLA.

EPCRA established a list of extremely hazardous substances (EHS) that could cause serious irreversible health effects from accidental releases. Many substances appear on both the CERCLA and EPCRA lists. EPCRA extremely hazardous substances that are also CERCLA hazardous substances have the same reportable quantity (RQ) as under CERCLA. EPCRA extremely hazardous substances that are not listed under CERCLA have a reportable quantity that is equal to their threshold planning quantity (TPQ). A list of CERCLA reportable quantities is included in 40 CFR Section 302.4. A list of EPCRA threshold planning quantities is included in 40 CFR Part 355 Appendices A & B.

CERCLA-reportable releases must be reported immediately to the National Response Center (NRC), while EPCRA-reportable releases must be reported immediately to the National Response Center, the State Emergency Response Commission (SERC) and the affected Local Emergency Planning Committee (LEPC). If the release is an EPCRA extremely

hazardous substance, but not a CERCLA hazardous substance, and there is absolutely no potential to affect off-site persons, then only the State Emergency Planning Commission (represented by CDPHE for reporting purposes) and the Local Emergency Planning Committee need to be notified.

In the case of a release of hazardous waste stored in tanks, RCRA-permitted facilities and large quantity generators must also notify CDPHE within 24 hours of any release to the environment that is greater than one (1) pound.

### Radiation Control

Each licensee or registrant must report to the Radiation Incident Reporting Line in the event of lost, stolen or missing licensed or registered radioactive materials or radiation machines, releases of radioactive materials, contamination events, and fires or explosions involving radioactive materials. Releases of radionuclides are reportable under CERCLA.

### Clean Water Act

The Clean Water Act requires the person in charge of a facility or vessel to immediately report to the National Response Center all discharges of oil or designated hazardous substances to water. Oil means oil of any kind or form. Designated hazardous substances are included in the CERCLA list.

The Clean Water Act also requires that facilities with a National Pollutant Discharge Elimination System (NPDES) permit report to the National Response Center within 24 hours of becoming aware of any unanticipated bypasses or upsets that cause an exceedance of the effluent limits in their permit and any violations of their maximum daily discharge limits for pollutants listed in their permit.

A release of any chemical, oil, petroleum product, sewage, etc., which may enter waters of the state of Colorado (which include surface water, ground water and dry gullies and storm sewers leading to surface water) must be reported immediately to CDPHE. Any accidental discharge to the sanitary sewer system must be reported immediately to the local sewer authority and the affected wastewater treatment plant. For additional regarding releases to water, please see "Guidance for Reporting Spills under the Colorado

Water Quality Control Act and Colorado Discharge Permits" at <http://www.cdph.state.co.us/op/wqcc/Resources/Guidance/spillguidance.pdf>.

### Clean Air Act

Hazardous air pollutants (HAPs) are designated as hazardous substances under CERCLA. If a facility has an air permit but the permit does not allow for or does not specify the release of a substance, or if the facility does not have an air permit, then all releases in excess of the CERCLA / EPCRA reportable quantity for that substance must be reported to the National Response Center and CDPHE. If the facility releases more of a substance than is allowed under its air permit, the facility must also report the release. Discharges of a substance that are within the allowable limits specified in the facility's permit do not need to be reported.

### Regulated Storage Tanks

Owners and operators of regulated storage tank systems must report a release or suspected release of regulated substances to the Division of Oil and Public Safety at the Colorado Department of Labor and Employment within 24 hours. Under this program, the reportable quantity for petroleum releases is 25 gallons or more, or any amount that causes a sheen on nearby surface water. Spills of less than 25 gallons of petroleum must be immediately contained and cleaned up. If cleanup cannot be accomplished within 24 hours, the Division of Oil and Public Safety must be notified immediately.

Spills of hazardous substances from tanks in excess of the CERCLA or EPCRA reportable quantity must be reported immediately to the National Response Center, CDPHE and the local fire authority, and to the Division of Oil and Public Safety within 24 hours.

### Transportation and Pipelines

The person in physical possession of a hazardous material must notify the National Response Center as soon as practical, but not to exceed 12 hours after the incident. If as a direct result of the hazardous material, a person is killed or injured, there is an evacuation of the general public lasting more than an hour, a major transportation artery is shut down for an hour or more, the flight pattern of an aircraft is altered, there is fire, spillage or suspected contamination

WATER QUALITY  
CONTROL  
DIVISION

Policy No: WQE-10

Initiated By: Dave Akers

Approved By: 

Effective Date: 3/1/08

Revision No.:

Revision Date:

Guidance for Reporting Spills under the Colorado Water Quality  
Control Act and Colorado Discharge Permits

**I. Purpose**

To provide guidance on applicable Colorado reporting requirements pursuant to § 25-8-601(2), C.R.S., that pertains to spills or discharges that may cause pollution of State waters. This guidance does not relieve an entity of any other statutory or regulatory requirements applicable to a spill. Facilities possessing a Colorado Discharge Permit System (CDPS) permit should follow applicable permit terms and conditions regarding spill reporting and response. This guidance is not intended to supersede or modify such permit terms and conditions or the applicable statute and regulations. This guidance does not limit the existing rights or responsibilities of persons with respect to spill reporting. For example, persons retain the right and responsibility to determine in the first instance whether a particular spill is covered by an existing permit or may cause pollution to State waters (i.e., surface or ground waters).

**II. Statutory Requirement Addressed**

Colorado Water Quality Control Act - Spill Reporting Requirements - § 25-8-601(2), C.R.S.

“Any person engaged in any operation or activity which results in a spill or discharge of oil or other substance which may cause pollution of the waters of the state contrary to the provisions of this article as soon as he has knowledge thereof, shall notify the division of such discharge.”

State waters means any and all surface and subsurface waters which are contained in or flow in or through this state, but does not include waters in sewage systems, waters in treatment works of disposal systems, waters in potable water distribution systems, and all water withdrawn for use until use and treatment have been completed (§ 25-8-103 (19), C.R.S.).

Examples of State waters include, but are not limited to, perennial streams, intermittent or ephemeral gulches and arroyos, ponds, lakes, reservoirs, irrigation canals or ditches, wetlands, stormwater conveyances (when they discharge to a surface water), and groundwater.

**III. Policy/Applicability**

The Division distinguishes between reporting requirements for spills that occur with respect to activities that result in a discharge that is authorized under a CDPS permit and those that are not. For non-permitted activities, or in the case of an activity where a permit does not address reporting of or response to a given spill, the Division recommends that the responsible person(s) take the following actions:

1. Immediately report spills that may result in a non-permitted discharge of pollutants to State waters to the Environmental Release and Incident Reporting Line at 1-877-518-5608;
2. Include the following information, if available, when notifying the Division of a spill:
  - a. The name of the responsible person and, if not reported by that person, the name of the person reporting the spill and the name of the responsible person if known;
  - b. An estimate of the date and time that the spill began or the actual date and time, if known;

- c. The location of the spill, its source (e.g., manhole, tanker truck), and identification of the type of material spilled (e.g., untreated wastewater, biosolids, specific chemical);
- d. The estimated volume of the spill and, if known, the actual date and time the spill was fully controlled/stopped.
- e. Whether the spill is ongoing and, if it is, the rate of flow and an estimate of the time that the spill will be fully controlled, if known;
- f. Measures that are being or have been taken to contain, reduce, and/or clean up the spill;
- g. A list of any potentially affected area and any known downstream water uses (e.g., public water supplies, irrigation diversions, public use areas such as parks or swim beaches) that will be or have been notified; and
- h. A phone number and e-mail to contact a representative of the responsible person that is in charge of the response. Where a non-responsible person is reporting the spill, they are encouraged, but not required, to provide contact information.

Reporting and management of spills that occur with respect to activities resulting in a discharge authorized under a permit should be performed in accordance with the specific requirements of that permit. If the permit does not provide specific reporting or management response requirements for a given spill that may pollute State waters, the Division recommends that the responsible person report the spill in accordance with the procedures listed above.

This guidance only addresses reporting requirements under the Division's authority. The person or entity engaged in any operation or activity that results in a spill is responsible for any other applicable reporting requirements associated with the spill to other regulatory agencies.

Section 25-8-601(2), C.R.S. only addresses spill reporting to the Division. Section 25-8-202(7), C.R.S. provides certain water quality responsibilities to other state "implementing agencies." The Division's position is that, where a spill to the ground that may impact ground water only is fully and timely reported to an implementing agency having jurisdiction over that spill, the intent of section 601(2) has been fulfilled, and the spill need not also be reported to the Division. The Division suggests that the responsible person confirm with the implementing agency that a spill falls under the jurisdiction of the implementing agency at the time it is reported in order to avoid possible legal liability should it fall under the Division's jurisdiction.

#### **IV. Division Examples of Non-Reportable Spills**

The Division has identified the following examples of types of spills that are considered "non-reportable" under § 25-8-601(2), C.R.S. Documentation of such spills, including the information listed in section III.2.a – III.2.f above, should be maintained by the responsible person for Division review for a period of three years.

1. A spill to a generally impervious surface or structure (e.g., paved street/parking lot, storm sewer, warehouse floor, manhole, vault, concrete basement), or onto soils, that is fully contained in/on the impervious surface/structure or soils, or that is managed in a manner so that it will not reach State waters at the time of the spill or in the future. Such spills that are cleaned up within 24 hours will be considered by the Division to have no potential to reach State waters. However, even if such spills are not cleaned up within 24 hours, the responsible person may be able to "fully contain" or otherwise manage a spill such that it will not reach State waters. Where there is a sump pump present in a basement to which a spill occurred, the responsible person must establish that the pump did not discharge to State waters during the time between the start of the spill and the completion of clean-up in accordance with best management practices.
2. A spill or discharge that is managed consistent with best management practices that are established in accordance with a CDPS discharge permit or any Water Quality Control Commission-adopted control regulation related to spill management or reporting.
3. A spill of potable water from a public water system that does not reach surface waters.

<input checked="" type="checkbox"/> Field Services - Grand Junction 222 South 6th Street, Room 232 Grand Junction, CO 81501 Telephone: 970-248-7150 Fax: 970-248-7198 Contact email: <a href="mailto:michelle.thiebaud@state.co.us">michelle.thiebaud@state.co.us</a>	<input type="checkbox"/> Field Services - Pueblo 140 Central Main, Suite 300 Pueblo, CO 81003 Telephone: 719-295-5060 Fax: 719-543-8441 Contact email: <a href="mailto:carol.keever@state.co.us">carol.keever@state.co.us</a>	<input type="checkbox"/> Field Services - Denver 4300 Cherry Creek Dr. South, B2 Denver, Colorado 80246-1530 Phone: 303-692-3650 Fax: 303-782-0390 Contact email: <a href="mailto:annemarie.goolsby@state.co.us">annemarie.goolsby@state.co.us</a>
---	---	--

**Reporting Form: Incident / Spill / Sanitary Sewer Overflow (SSO)**

The Water Quality Control Division distinguishes between reporting requirements for spills that occur with respect to activities that result in a discharge that is authorized under a CDPS permit and those that are not. Reporting and management of spills that occur with respect to activities resulting in a discharge authorized under a permit should be performed in accordance with the specific requirements of that permit. If the permit does not require a 5-day report, please provide the information below in writing. For non-permitted activities, or in the case of an activity where a permit does not address reporting of or response to a given spill, please submit this written response to the Water Quality Control Division within five (5) working days of the date of the event. If sufficient space is not provided, please attach other sheets. Please send the completed form with signature via fax or email to the Division's Field Services office indicated above. If you have any questions please contact the Division's Field Services Engineer at your earliest convenience. The Field Services County list is available at: <http://www.colorado.gov/cdphe/wqcd> (Contacts, Inspection services contacts, then Field services contacts).

Prior to the five (5) working day deadline, you may request an extension to submit the report if sample analyses justifiably are going to require more time to analyze than the reporting time allows. To request an extension please send an email to the Division's Field Services Engineer for the County that the incident / spill / SSO took place or to the email listed above.

Incident Background Information			
County			
Incident / Spill Number (Division provided) and Spill Date			
Type of Incident / Spill / SSO (check one)	<input type="checkbox"/> Sanitary Sewer Overflow/Reuse	<input type="checkbox"/> Petroleum Product	<input type="checkbox"/> Chemical
	<input type="checkbox"/> WW Treatment Plant Bypass or Upset (through an authorized outfall point)	<input type="checkbox"/> WW Treatment Plant Spill or Overflow (other than outfall)	<input type="checkbox"/> Biosolids
	<input type="checkbox"/> Unplanned potable water release (e.g., water line break)		<input type="checkbox"/> Other
Contact Information			
Potentially Responsible Party (PRP): Contact Name		Potentially Responsible Party (PRP): Company / Agency	
PRP Phone / Fax	Phone: Fax:	PRP email address	
CDPS Permit Number:		CDPS Permittee Name:	
Reported by (if not PRP): Contact Name		Reported by (if not PRP): Company / Agency	
Reported by (if not PRP): Phone / Fax	Phone: Fax:	Reported by (if not PRP): email address	
Incident Information: Please provide the following information.			
A	Incident / spill / SSO source, cause, and event description.		
	Response:		
B	Material released (e.g., untreated wastewater, biosolids, specific chemicals or products) and estimated total quantity (e.g., gallons). Please attach MSDS for any and all chemicals or products involved in spill or release.		
	Response:		
C	Actual or estimated dates and times of the event, including duration and actual date and time spill was fully controlled/stopped. If release is still occurring, the date and time the release is expected to be stopped.		
	Response:		

D	Location of release (e.g., address, lat/long, road name and mile marker).
	Response:
E	Describe measures taken or planned to contain, reduce, and clean up spill or release.
	Response:
F	Steps taken or planned to prevent reoccurrence of the event.
	Response:
<b>Incident Impact to State Waters (As defined in § 25-8-103(19), C.R.S.).</b> <i>Examples of State waters include: perennial streams, intermittent or ephemeral gulches, ditches, ponds, lakes, reservoirs, irrigation canals, wetlands, stormwater conveyances (when they discharge to surface water), and groundwater.</i>	
G	Did flow or materials reach surface waters of the State? If so, please describe the path of flow to State waters and which State water body was impacted (e.g., spill impacted a storm drain which was directly connected to Cherry Creek, Colorado River, etc.). If yes, what quantity of material (e.g., gallons) reached the surface water and what was the resulting impact?
	Response:
H	Were any water quality samples or other samples taken? If so, please describe sampling process and attached results.
	Response:
I	Did flow or materials reach groundwater of the State? If so, please describe the path of flow to State waters and which State water body impacted (e.g., spill soaked into ground and wet soil was not excavated). If yes, what quantity of material (e.g., gallons) reached the ground or groundwater and what was the resulting impact?
	Response:
J	Did the incident include any of the following (check if yes)? If so, please include additional details below.
	<input type="checkbox"/> Toxic Chemical Release <input type="checkbox"/> Fish Kill
	Response:
<b>Incident Impact to Areas or Water Users</b>	
K	Did the incident / spill / SSO impact any areas (e.g., public use areas including parks or swim beaches) or downstream water users (e.g., public water suppliers, irrigation diversions)? Please list impacted areas and/or users, their location, and potential impacts.
	Response:
L	How were the impacted area users (e.g., park patrons) and downstream water users notified (e.g., signs posted, list downstream users contact via phone).
	Response:

I hereby certify that the information presented above is accurate and complete.			
Date	Company	Typed Name and Title	Signature

## BMP CONSTRUCTION DETAILS



## Description

Vehicle tracking controls provide stabilized construction site access where vehicles exit the site onto paved public roads. An effective vehicle tracking control helps remove sediment (mud or dirt) from vehicles, reducing tracking onto the paved surface.



**Photograph VTC-1.** A vehicle tracking control pad constructed with properly sized rock reduces off-site sediment tracking.

## Appropriate Uses

Implement a stabilized construction entrance or vehicle tracking control where frequent heavy vehicle traffic exits the construction site onto a paved roadway. An effective vehicle tracking control is particularly important during the following conditions:

- Wet weather periods when mud is easily tracked off site.
- During dry weather periods where dust is a concern.
- When poorly drained, clayey soils are present on site.

Although wheel washes are not required in designs of vehicle tracking controls, they may be needed at particularly muddy sites.

## Design and Installation

Construct the vehicle tracking control on a level surface. Where feasible, grade the tracking control towards the construction site to reduce off-site runoff. Place signage, as needed, to direct construction vehicles to the designated exit through the vehicle tracking control. There are several different types of stabilized construction entrances including:

**VTC-1. Aggregate Vehicle Tracking Control.** This is a coarse-aggregate surfaced pad underlain by a geotextile. This is the most common vehicle tracking control, and when properly maintained can be effective at removing sediment from vehicle tires.

**VTC-2. Vehicle Tracking Control with Construction Mat or Turf Reinforcement Mat.** This type of control may be appropriate for site access at very small construction sites with low traffic volume over vegetated areas. Although this application does not typically remove sediment from vehicles, it helps protect existing vegetation and provides a stabilized entrance.

Vehicle Tracking Control	
<b>Functions</b>	
Erosion Control	Moderate
Sediment Control	Yes
Site/Material Management	Yes

**VTC-3. Stabilized Construction Entrance/Exit with Wheel Wash.** This is an aggregate pad, similar to VTC-1, but includes equipment for tire washing. The wheel wash equipment may be as simple as hand-held power washing equipment to more advanced proprietary systems. When a wheel wash is provided, it is important to direct wash water to a sediment trap prior to discharge from the site.

Vehicle tracking controls are sometimes installed in combination with a sediment trap to treat runoff.

## Maintenance and Removal

Inspect the area for degradation and replace aggregate or material used for a stabilized entrance/exit as needed. If the area becomes clogged and ponds water, remove and dispose of excess sediment or replace material with a fresh layer of aggregate as necessary.

With aggregate vehicle tracking controls, ensure rock and debris from this area do not enter the public right-of-way.

Remove sediment that is tracked onto the public right of way daily or more frequently as needed. Excess sediment in the roadway indicates that the stabilized construction entrance needs maintenance.

Ensure that drainage ditches at the entrance/exit area remain clear.

A stabilized entrance should be removed only when there is no longer the potential for vehicle tracking to occur. This is typically after the site has been stabilized.

When wheel wash equipment is used, be sure that the wash water is discharged to a sediment trap prior to discharge. Also inspect channels conveying the water from the wash area to the sediment trap and stabilize areas that may be eroding.

When a construction entrance/exit is removed, excess sediment from the aggregate should be removed and disposed of appropriately. The entrance should be promptly stabilized with a permanent surface following removal, typically by paving.



**Photograph VTC-2.** A vehicle tracking control pad with wheel wash facility. Photo courtesy of Tom Gore.



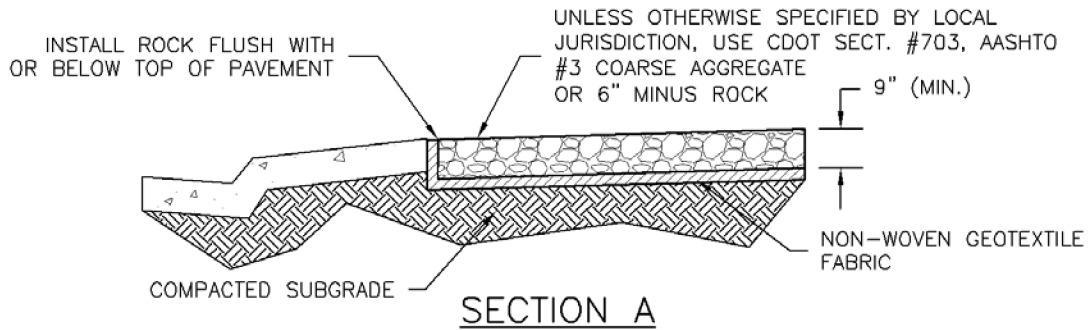
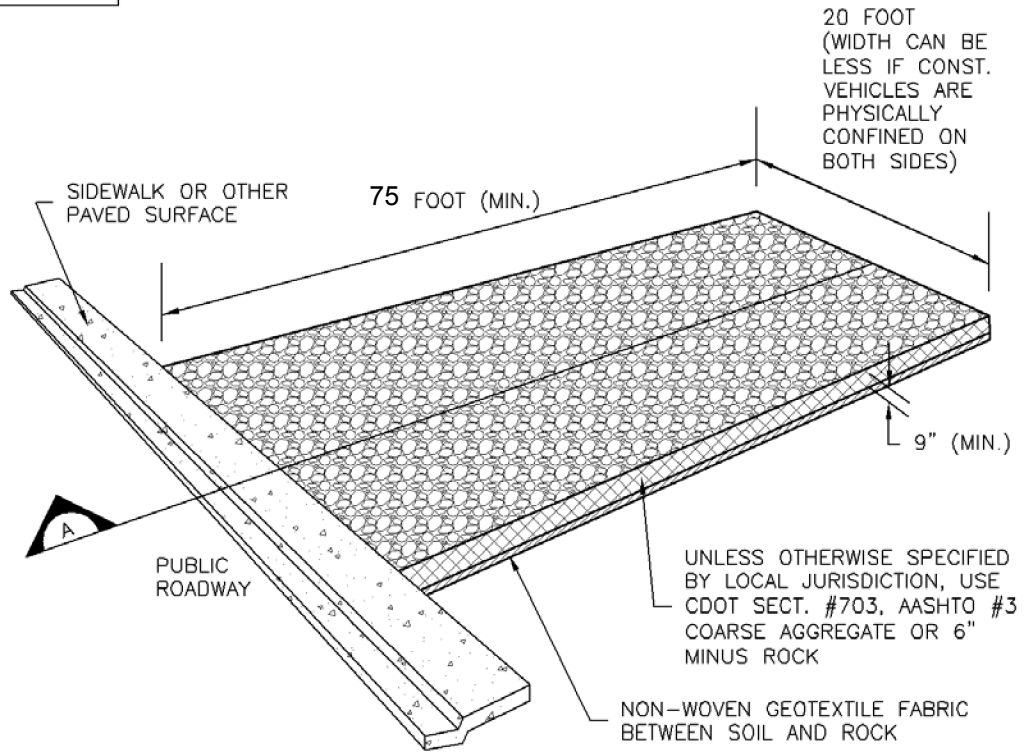
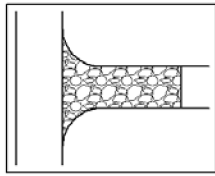

## VTC-1. AGGREGATE VEHICLE TRACKING CONTROL

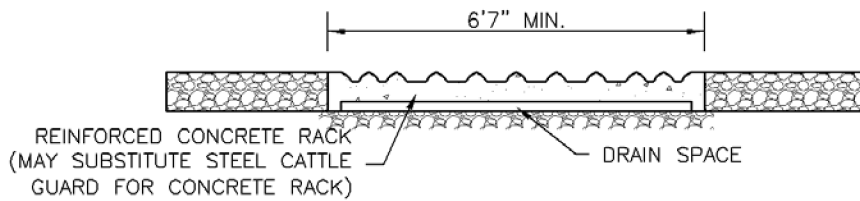
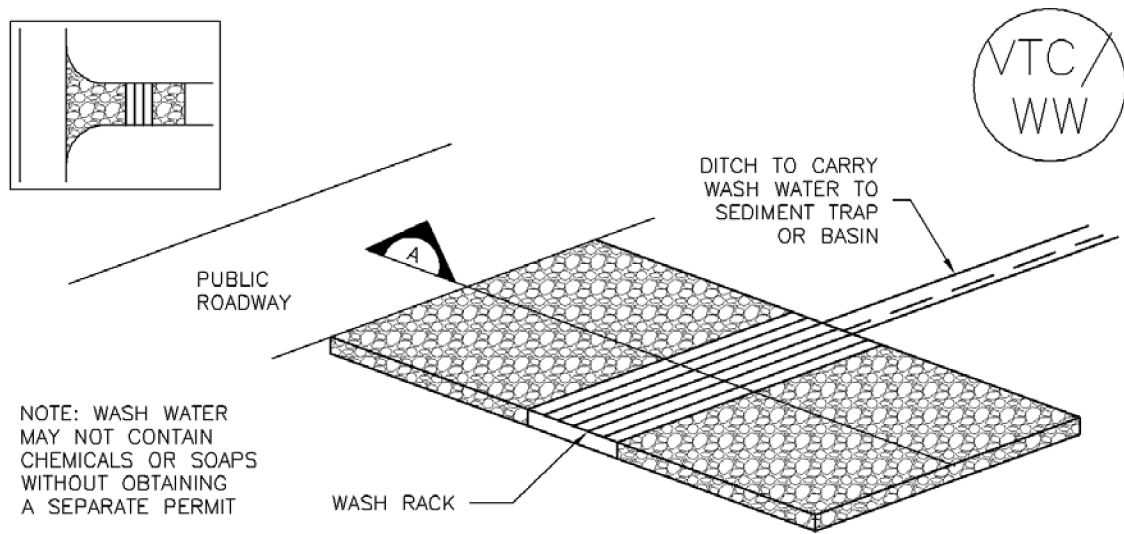

SECTION A

VTC-2. AGGREGATE VEHICLE TRACKING CONTROL WITH WASH RACK

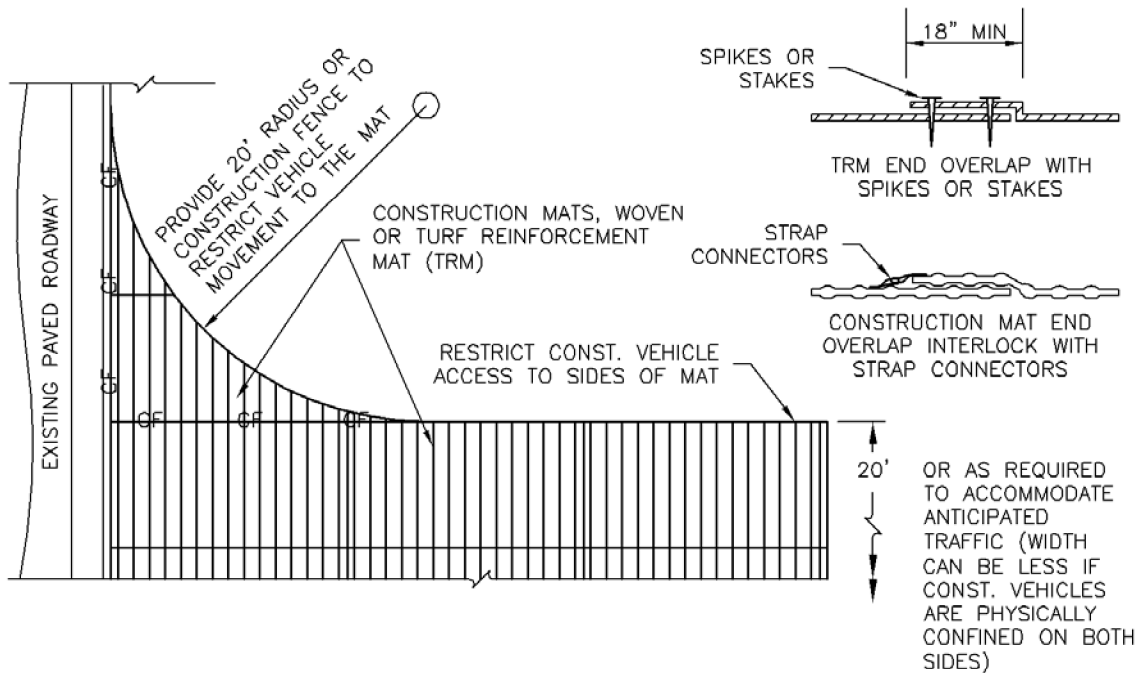
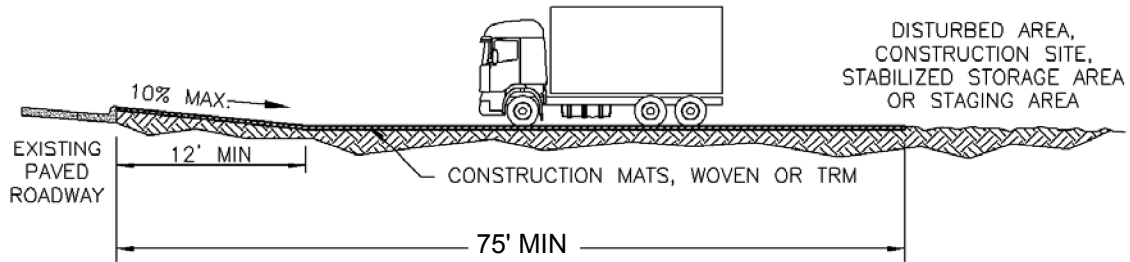
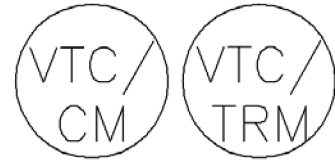
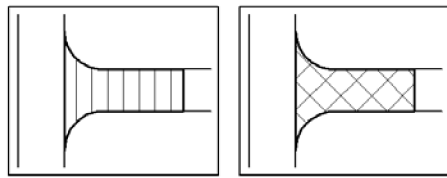

### VTC-3. VEHICLE TRACKING CONTROL W/ CONSTRUCTION MAT OR TURF REINFORCEMENT MAT (TRM)

STABILIZED CONSTRUCTION ENTRANCE/EXIT INSTALLATION NOTES

1. SEE PLAN VIEW FOR
  - LOCATION OF CONSTRUCTION ENTRANCE(S)/EXIT(S).
  - TYPE OF CONSTRUCTION ENTRANCE(S)/EXITS(S) (WITH/WITHOUT WHEEL WASH, CONSTRUCTION MAT OR TRM).
2. CONSTRUCTION MAT OR TRM STABILIZED CONSTRUCTION ENTRANCES ARE ONLY TO BE USED ON SHORT DURATION PROJECTS (TYPICALLY RANGING FROM A WEEK TO A MONTH) WHERE THERE WILL BE LIMITED VEHICULAR ACCESS.
3. A STABILIZED CONSTRUCTION ENTRANCE/EXIT SHALL BE LOCATED AT ALL ACCESS POINTS WHERE VEHICLES ACCESS THE CONSTRUCTION SITE FROM PAVED RIGHT-OF-WAYS.
4. STABILIZED CONSTRUCTION ENTRANCE/EXIT SHALL BE INSTALLED PRIOR TO ANY LAND DISTURBING ACTIVITIES.
5. A NON-WOVEN GEOTEXTILE FABRIC SHALL BE PLACED UNDER THE STABILIZED CONSTRUCTION ENTRANCE/EXIT PRIOR TO THE PLACEMENT OF ROCK.
6. UNLESS OTHERWISE SPECIFIED BY LOCAL JURISDICTION, ROCK SHALL CONSIST OF DOT SECT. #703, AASHTO #3 COARSE AGGREGATE OR 6" (MINUS) ROCK.

STABILIZED CONSTRUCTION ENTRANCE/EXIT MAINTENANCE NOTES

1. INSPECT BMPs EACH WORKDAY, AND MAINTAIN THEM IN EFFECTIVE OPERATING CONDITION. MAINTENANCE OF BMPs SHOULD BE PROACTIVE, NOT REACTIVE. INSPECT BMPs AS SOON AS POSSIBLE (AND ALWAYS WITHIN 24 HOURS) FOLLOWING A STORM THAT CAUSES SURFACE EROSION, AND PERFORM NECESSARY MAINTENANCE.
2. FREQUENT OBSERVATIONS AND MAINTENANCE ARE NECESSARY TO MAINTAIN BMPs IN EFFECTIVE OPERATING CONDITION. INSPECTIONS AND CORRECTIVE MEASURES SHOULD BE DOCUMENTED THOROUGHLY.
3. WHERE BMPs HAVE FAILED, REPAIR OR REPLACEMENT SHOULD BE INITIATED UPON DISCOVERY OF THE FAILURE.
4. ROCK SHALL BE REAPPLIED OR REGRADED AS NECESSARY TO THE STABILIZED ENTRANCE/EXIT TO MAINTAIN A CONSISTENT DEPTH.
5. SEDIMENT TRACKED ONTO PAVED ROADS IS TO BE REMOVED THROUGHOUT THE DAY AND AT THE END OF THE DAY BY SHOVELING OR SWEEPING. SEDIMENT MAY NOT BE WASHED DOWN STORM SEWER DRAINS.

NOTE: MANY JURISDICTIONS HAVE BMP DETAILS THAT VARY FROM UDFCD STANDARD DETAILS. CONSULT WITH LOCAL JURISDICTIONS AS TO WHICH DETAIL SHOULD BE USED WHEN DIFFERENCES ARE NOTED.

(DETAILS ADAPTED FROM CITY OF BROOMFIELD, COLORADO, NOT AVAILABLE IN AUTOCAD)

## Description

A silt fence is a woven geotextile fabric attached to wooden posts and trenched into the ground. It is designed as a sediment barrier to intercept sheet flow runoff from disturbed areas.

## Appropriate Uses

A silt fence can be used where runoff is conveyed from a disturbed area as sheet flow. Silt fence is not designed to receive concentrated flow or to be used as a filter fabric. Typical uses include:

- Down slope of a disturbed area to accept sheet flow.
- Along the perimeter of a receiving water such as a stream, pond or wetland.
- At the perimeter of a construction site.



**Photograph SF-1.** Silt fence creates a sediment barrier, forcing sheet flow runoff to evaporate or infiltrate.

## Design and Installation

Silt fence should be installed along the contour of slopes so that it intercepts sheet flow. The maximum recommended tributary drainage area per 100 lineal feet of silt fence, installed along the contour, is approximately 0.25 acres with a disturbed slope length of up to 150 feet and a tributary slope gradient no steeper than 3:1. Longer and steeper slopes require additional measures. This recommendation only applies to silt fence installed along the contour. Silt fence installed for other uses, such as perimeter control, should be installed in a way that will not produce concentrated flows. For example, a "J-hook" installation may be appropriate to force runoff to pond and evaporate or infiltrate in multiple areas rather than concentrate and cause erosive conditions parallel to the silt fence.

See Detail SF-1 for proper silt fence installation, which involves proper trenching, staking, securing the fabric to the stakes, and backfilling the silt fence. Properly installed silt fence should not be easily pulled out by hand and there should be no gaps between the ground and the fabric.

Silt fence must meet the minimum allowable strength requirements, depth of installation requirement, and other specifications in the design details. Improper installation of silt fence is a common reason for silt fence failure; however, when properly installed and used for the appropriate purposes, it can be highly effective.

<b>Silt Fence</b>	
<b>Functions</b>	
Erosion Control	No
Sediment Control	Yes
Site/Material Management	No

## Maintenance and Removal

Inspection of silt fence includes observing the material for tears or holes and checking for slumping fence and undercut areas bypassing flows. Repair of silt fence typically involves replacing the damaged section with a new section. Sediment accumulated behind silt fence should be removed, as needed to maintain BMP effectiveness, typically before it reaches a depth of 6 inches.

Silt fence may be removed when the upstream area has reached final stabilization.



**Photograph SF-2.** When silt fence is not installed along the contour, a "J-hook" installation may be appropriate to ensure that the BMP does not create concentrated flow parallel to the silt fence. Photo courtesy of Tom Gore.

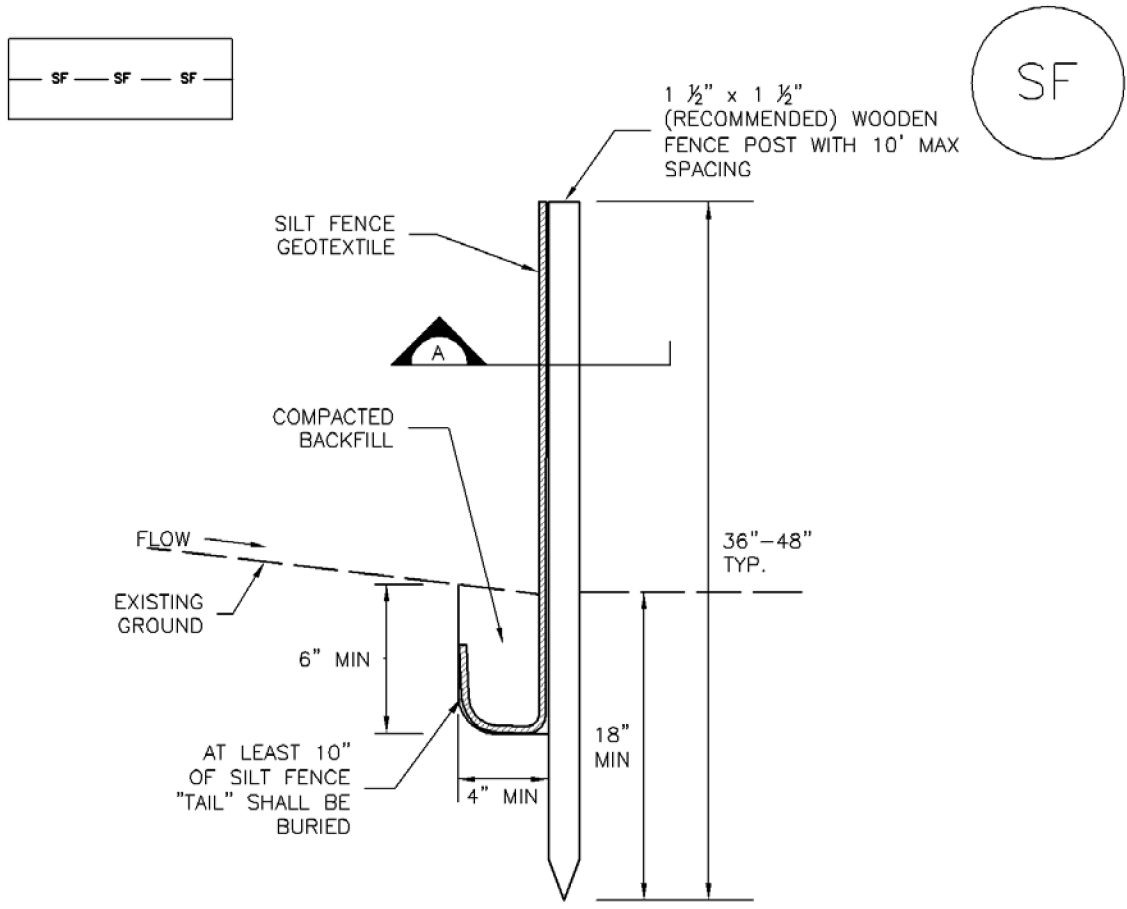

## SILT FENCE

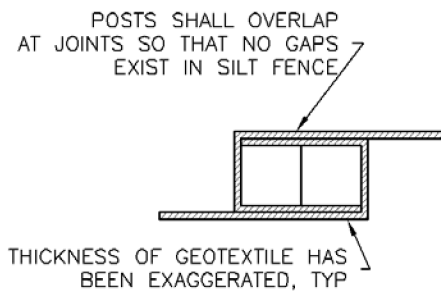
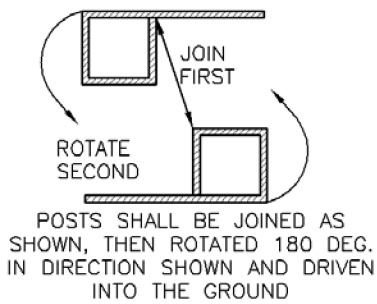

## SECTION A

## SF-1. SILT FENCE

SILT FENCE INSTALLATION NOTES

1. SILT FENCE MUST BE PLACED AWAY FROM THE TOE OF THE SLOPE TO ALLOW FOR WATER PONDING. SILT FENCE AT THE TOE OF A SLOPE SHOULD BE INSTALLED IN A FLAT LOCATION AT LEAST SEVERAL FEET (2-5 FT) FROM THE TOE OF THE SLOPE TO ALLOW ROOM FOR PONDING AND DEPOSITION.
2. A UNIFORM 6" X 4" ANCHOR TRENCH SHALL BE EXCAVATED USING TRENCHER OR SILT FENCE INSTALLATION DEVICE. NO ROAD GRADERS, BACKHOES, OR SIMILAR EQUIPMENT SHALL BE USED.
3. COMPACT ANCHOR TRENCH BY HAND WITH A "JUMPING JACK" OR BY WHEEL ROLLING. COMPACTION SHALL BE SUCH THAT SILT FENCE RESISTS BEING PULLED OUT OF ANCHOR TRENCH BY HAND.
4. SILT FENCE SHALL BE PULLED TIGHT AS IT IS ANCHORED TO THE STAKES. THERE SHOULD BE NO NOTICEABLE SAG BETWEEN STAKES AFTER IT HAS BEEN ANCHORED TO THE STAKES.
5. SILT FENCE FABRIC SHALL BE ANCHORED TO THE STAKES USING 1" HEAVY DUTY STAPLES OR NAILS WITH 1" HEADS. STAPLES AND NAILS SHOULD BE PLACED 3" ALONG THE FABRIC DOWN THE STAKE.
6. AT THE END OF A RUN OF SILT FENCE ALONG A CONTOUR, THE SILT FENCE SHOULD BE TURNED PERPENDICULAR TO THE CONTOUR TO CREATE A "J-HOOK." THE "J-HOOK" EXTENDING PERPENDICULAR TO THE CONTOUR SHOULD BE OF SUFFICIENT LENGTH TO KEEP RUNOFF FROM FLOWING AROUND THE END OF THE SILT FENCE (TYPICALLY 10' - 20').
7. SILT FENCE SHALL BE INSTALLED PRIOR TO ANY LAND DISTURBING ACTIVITIES.

SILT FENCE MAINTENANCE NOTES

1. INSPECT BMPs EACH WORKDAY, AND MAINTAIN THEM IN EFFECTIVE OPERATING CONDITION. MAINTENANCE OF BMPs SHOULD BE PROACTIVE, NOT REACTIVE. INSPECT BMPs AS SOON AS POSSIBLE (AND ALWAYS WITHIN 24 HOURS) FOLLOWING A STORM THAT CAUSES SURFACE EROSION, AND PERFORM NECESSARY MAINTENANCE.
2. FREQUENT OBSERVATIONS AND MAINTENANCE ARE NECESSARY TO MAINTAIN BMPs IN EFFECTIVE OPERATING CONDITION. INSPECTIONS AND CORRECTIVE MEASURES SHOULD BE DOCUMENTED THOROUGHLY.
3. WHERE BMPs HAVE FAILED, REPAIR OR REPLACEMENT SHOULD BE INITIATED UPON DISCOVERY OF THE FAILURE.
4. SEDIMENT ACCUMULATED UPSTREAM OF THE SILT FENCE SHALL BE REMOVED AS NEEDED TO MAINTAIN THE FUNCTIONALITY OF THE BMP, TYPICALLY WHEN DEPTH OF ACCUMULATED SEDIMENTS IS APPROXIMATELY 6".
5. REPAIR OR REPLACE SILT FENCE WHEN THERE ARE SIGNS OF WEAR, SUCH AS SAGGING, TEARING, OR COLLAPSE.
6. SILT FENCE IS TO REMAIN IN PLACE UNTIL THE UPSTREAM DISTURBED AREA IS STABILIZED AND APPROVED BY THE LOCAL JURISDICTION, OR IS REPLACED BY AN EQUIVALENT PERIMETER SEDIMENT CONTROL BMP.
7. WHEN SILT FENCE IS REMOVED, ALL DISTURBED AREAS SHALL BE COVERED WITH TOPSOIL, SEEDED AND MULCHED OR OTHERWISE STABILIZED AS APPROVED BY LOCAL JURISDICTION.

(DETAIL ADAPTED FROM TOWN OF PARKER, COLORADO AND CITY OF AURORA, NOT AVAILABLE IN AUTOCAD)

NOTE: MANY JURISDICTIONS HAVE BMP DETAILS THAT VARY FROM UDFCD STANDARD DETAILS. CONSULT WITH LOCAL JURISDICTIONS AS TO WHICH DETAIL SHOULD BE USED WHEN DIFFERENCES ARE NOTED.



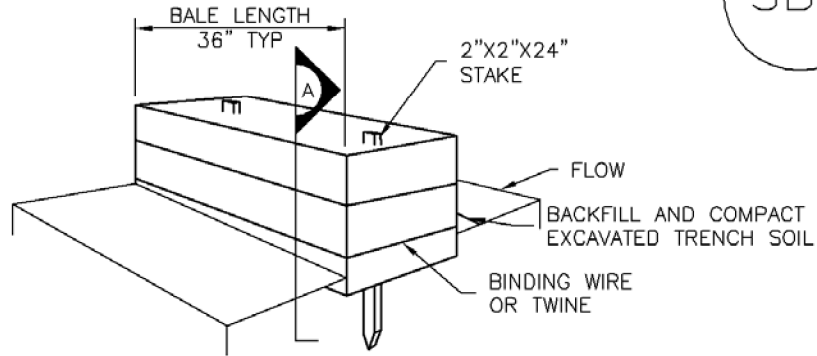

STRAW BALE

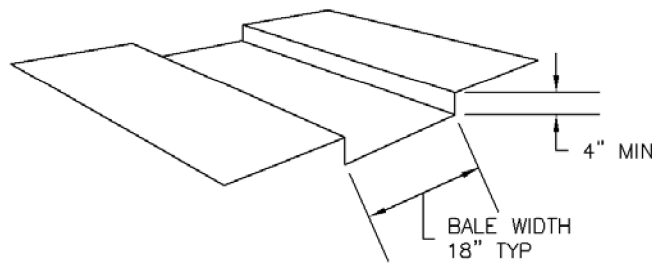

TRENCH FOR STRAW BALE

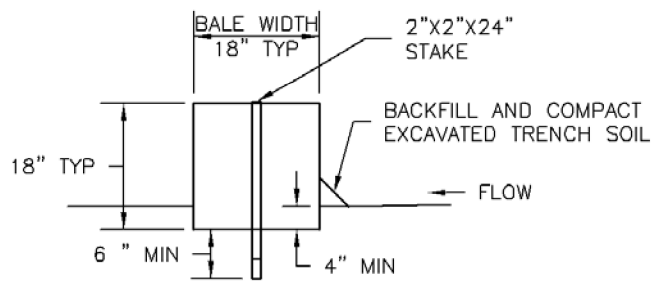

SECTION A

SBB-1. STRAW BALE

## STRAW BALE INSTALLATION NOTES

1. SEE PLAN VIEW FOR:  
-LOCATION(S) OF STRAW BALES.
2. STRAW BALES SHALL CONSIST OF CERTIFIED WEED FREE STRAW OR HAY. LOCAL JURISDICTIONS MAY REQUIRE PROOF THAT BALES ARE WEED FREE.
3. STRAW BALES SHALL CONSIST OF APPROXIMATELY 5 CUBIC FEET OF STRAW OR HAY AND WEIGH NOT LESS THAN 35 POUNDS.
4. WHEN STRAW BALES ARE USED IN SERIES AS A BARRIER, THE END OF EACH BALE SHALL BE TIGHTLY ABUTTING ONE ANOTHER.
5. STRAW BALE DIMENSIONS SHALL BE APPROXIMATELY 36"X18"X18".
6. A UNIFORM ANCHOR TRENCH SHALL BE EXCAVATED TO A DEPTH OF 4". STRAW BALES SHALL BE PLACED SO THAT BINDING TWINE IS ENCOMPASSING THE VERTICAL SIDES OF THE BALE(S). ALL EXCAVATED SOIL SHALL BE PLACED ON THE UPHILL SIDE OF THE STRAW BALE(S) AND COMPACTED.
7. TWO (2) WOODEN STAKES SHALL BE USED TO HOLD EACH BALE IN PLACE. WOODEN STAKES SHALL BE 2"X2"X24". WOODEN STAKES SHALL BE DRIVEN 6" INTO THE GROUND.

## STRAW BALE MAINTENANCE NOTES

1. INSPECT BMPs EACH WORKDAY, AND MAINTAIN THEM IN EFFECTIVE OPERATING CONDITION. MAINTENANCE OF BMPs SHOULD BE PROACTIVE, NOT REACTIVE. INSPECT BMPs AS SOON AS POSSIBLE (AND ALWAYS WITHIN 24 HOURS) FOLLOWING A STORM THAT CAUSES SURFACE EROSION, AND PERFORM NECESSARY MAINTENANCE.
2. FREQUENT OBSERVATIONS AND MAINTENANCE ARE NECESSARY TO MAINTAIN BMPs IN EFFECTIVE OPERATING CONDITION. INSPECTIONS AND CORRECTIVE MEASURES SHOULD BE DOCUMENTED THOROUGHLY.
3. WHERE BMPs HAVE FAILED, REPAIR OR REPLACEMENT SHOULD BE INITIATED UPON DISCOVERY OF THE FAILURE.
4. STRAW BALES SHALL BE REPLACED IF THEY BECOME HEAVILY SOILED, ROTTEN, OR DAMAGED BEYOND REPAIR.
5. SEDIMENT ACCUMULATED UPSTREAM OF STRAW BALE BARRIER SHALL BE REMOVED AS NEEDED TO MAINTAIN FUNCTIONALITY OF THE BMP, TYPICALLY WHEN DEPTH OF ACCUMULATED SEDIMENTS IS APPROXIMATELY  $\frac{1}{4}$  OF THE HEIGHT OF THE STRAW BALE BARRIER.
6. STRAW BALES ARE TO REMAIN IN PLACE UNTIL THE UPSTREAM DISTURBED AREA IS STABILIZED AND APPROVED BY THE LOCAL JURISDICTION.
7. WHEN STRAW BALES ARE REMOVED, ALL DISTURBED AREAS SHALL BE COVERED WITH TOPSOIL, SEEDED AND MULCHED OR OTHERWISE STABILIZED AS APPROVED BY LOCAL JURISDICTION.

(DETAILS ADAPTED FROM TOWN OF PARKER, COLORADO, NOT AVAILABLE IN AUTOCAD)

NOTE: MANY JURISDICTIONS HAVE BMP DETAILS THAT VARY FROM UDFCD STANDARD DETAILS. CONSULT WITH LOCAL JURISDICTIONS AS TO WHICH DETAIL SHOULD BE USED WHEN DIFFERENCES ARE NOTED.

## Description

Inlet protection consists of permeable barriers installed around an inlet to filter runoff and remove sediment prior to entering a storm drain inlet. Inlet protection can be constructed from rock socks, sediment control logs, silt fence, block and rock socks, or other materials approved by the local jurisdiction. Area inlets can also be protected by over-excavating around the inlet to form a sediment trap.



Photograph IP-1. Inlet protection for a curb opening inlet.

## Appropriate Uses

Install protection at storm sewer inlets that are operable during construction. Consider the potential for tracked-out sediment or temporary stockpile areas to contribute sediment to inlets when determining which inlets must be protected. This may include inlets in the general proximity of the construction area, not limited to downgradient inlets. Inlet protection is not a stand-alone BMP and should be used in conjunction with other upgradient BMPs.

## Design and Installation

To function effectively, inlet protection measures must be installed to ensure that flows do not bypass the inlet protection and enter the storm drain without treatment. However, designs must also enable the inlet to function without completely blocking flows into the inlet in a manner that causes localized flooding. When selecting the type of inlet protection, consider factors such as type of inlet (e.g., curb or area, sump or on-grade conditions), traffic, anticipated flows, ability to secure the BMP properly, safety and other site-specific conditions. For example, block and rock socks will be better suited to a curb and gutter along a roadway, as opposed to silt fence or sediment control logs, which cannot be properly secured in a curb and gutter setting, but are effective area inlet protection measures.

Several inlet protection designs are provided in the Design Details. Additionally, a variety of proprietary products are available for inlet protection that may be approved for use by local governments. If proprietary products are used, design details and installation procedures from the manufacturer must be followed. Regardless of the type of inlet protection selected, inlet protection is most effective when combined with other BMPs such as curb socks and check dams. Inlet protection is often the last barrier before runoff enters the storm sewer or receiving water.

Design details with notes are provided for these forms of inlet protection:

- IP-1. Block and Rock Sock Inlet Protection for Sump or On-grade Inlets
- IP-2. Curb (Rock) Socks Upstream of Inlet Protection, On-grade Inlets

Inlet Protection (various forms)	
<b>Functions</b>	
Erosion Control	No
Sediment Control	Yes
Site/Material Management	No

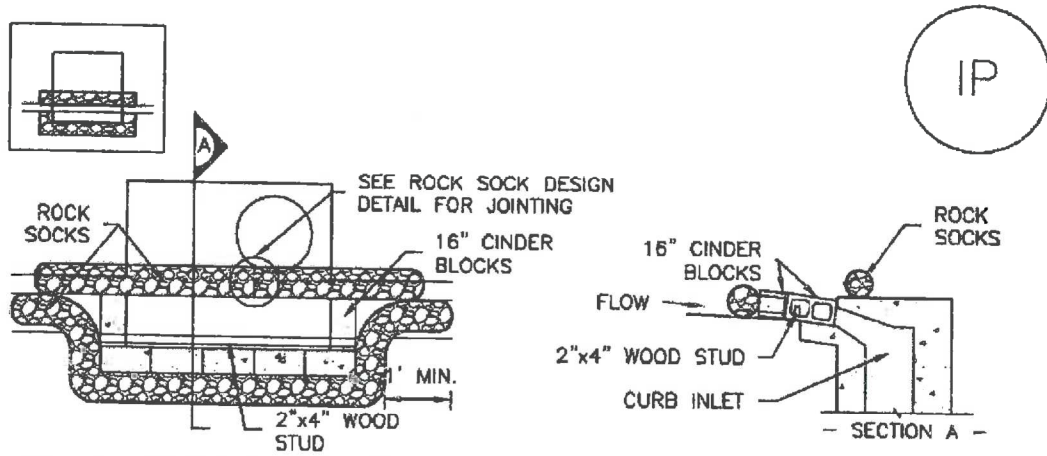

IP-1. BLOCK AND ROCK SOCK SUMP OR ON GRADE INLET PROTECTION

BLOCK AND CURB SOCK INLET PROTECTION INSTALLATION NOTES

1. SEE ROCK SOCK DESIGN DETAIL FOR INSTALLATION REQUIREMENTS.
2. CONCRETE "CINDER" BLOCKS SHALL BE LAID ON THEIR SIDES AROUND THE INLET IN A SINGLE ROW, ABUTTING ONE ANOTHER WITH THE OPEN END FACING AWAY FROM THE CURB.
3. GRAVEL BAGS SHALL BE PLACED AROUND CONCRETE BLOCKS, CLOSELY ABUTTING ONE ANOTHER AND JOINTED TOGETHER IN ACCORDANCE WITH ROCK SOCK DESIGN DETAIL.

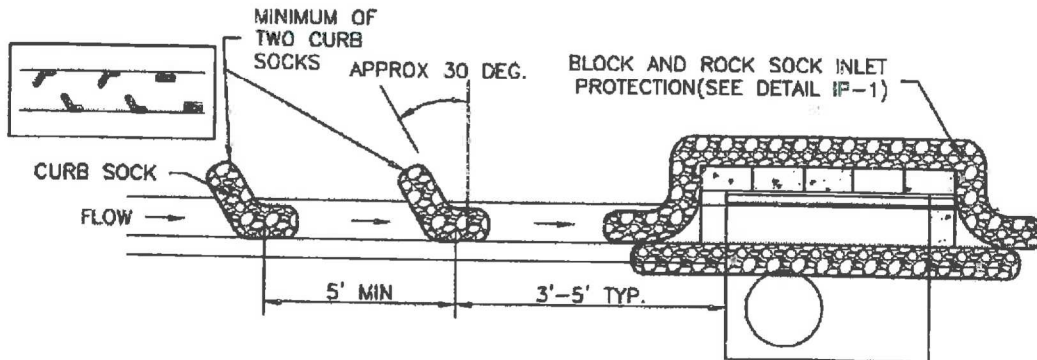

IP-2. CURB ROCK SOCKS UPSTREAM OF INLET PROTECTION

CURB ROCK SOCK INLET PROTECTION INSTALLATION NOTES

1. SEE ROCK SOCK DESIGN DETAIL INSTALLATION REQUIREMENTS.
2. PLACEMENT OF THE SOCK SHALL BE APPROXIMATELY 30 DEGREES FROM PERPENDICULAR IN THE OPPOSITE DIRECTION OF FLOW.
3. SOCKS ARE TO BE FLUSH WITH THE CURB AND SPACED A MINIMUM OF 5 FEET APART.
4. AT LEAST TWO CURB SOCKS IN SERIES ARE REQUIRED UPSTREAM OF ON-GRADE INLETS.



GENERAL INLET PROTECTION INSTALLATION NOTES

1. SEE PLAN VIEW FOR:
  - LOCATION OF INLET PROTECTION.
  - TYPE OF INLET PROTECTION (IP.1, IP.2, IP.3, IP.4, IP.5, IP.6)
2. INLET PROTECTION SHALL BE INSTALLED PROMPTLY AFTER INLET CONSTRUCTION OR PAVING IS COMPLETE (TYPICALLY WITHIN 48 HOURS). IF A RAINFALL/RUNOFF EVENT IS FORECAST, INSTALL INLET PROTECTION PRIOR TO ONSET OF EVENT.
3. MANY JURISDICTIONS HAVE BMP DETAILS THAT VARY FROM UDFCD STANDARD DETAILS. CONSULT WITH LOCAL JURISDICTIONS AS TO WHICH DETAIL SHOULD BE USED WHEN DIFFERENCES ARE NOTED.

INLET PROTECTION MAINTENANCE NOTES

1. INSPECT BMPs EACH WORKDAY, AND MAINTAIN THEM IN EFFECTIVE OPERATING CONDITION. MAINTENANCE OF BMPs SHOULD BE PROACTIVE, NOT REACTIVE. INSPECT BMPs AS SOON AS POSSIBLE (AND ALWAYS WITHIN 24 HOURS) FOLLOWING A STORM THAT CAUSES SURFACE EROSION, AND PERFORM NECESSARY MAINTENANCE.
2. FREQUENT OBSERVATIONS AND MAINTENANCE ARE NECESSARY TO MAINTAIN BMPs IN EFFECTIVE OPERATING CONDITION. INSPECTIONS AND CORRECTIVE MEASURES SHOULD BE DOCUMENTED THOROUGHLY.
3. WHERE BMPs HAVE FAILED, REPAIR OR REPLACEMENT SHOULD BE INITIATED UPON DISCOVERY OF THE FAILURE.
4. SEDIMENT ACCUMULATED UPSTREAM OF INLET PROTECTION SHALL BE REMOVED AS NECESSARY TO MAINTAIN BMP EFFECTIVENESS, TYPICALLY WHEN STORAGE VOLUME REACHES 50% OF CAPACITY, A DEPTH OF 6" WHEN SILT FENCE IS USED, OR ¼ OF THE HEIGHT FOR STRAW BALES.
5. INLET PROTECTION IS TO REMAIN IN PLACE UNTIL THE UPSTREAM DISTURBED AREA IS PERMANENTLY STABILIZED, UNLESS THE LOCAL JURISDICTION APPROVES EARLIER REMOVAL OF INLET PROTECTION IN STREETS.
6. WHEN INLET PROTECTION AT AREA INLETS IS REMOVED, THE DISTURBED AREA SHALL BE COVERED WITH TOP SOIL, SEEDED AND MULCHED, OR OTHERWISE STABILIZED IN A MANNER APPROVED BY THE LOCAL JURISDICTION.

(DETAIL ADAPTED FROM TOWN OF PARKER, COLORADO AND CITY OF AURORA, COLORADO, NOT AVAILABLE IN AUTOCAD)

**NOTE:** MANY JURISDICTIONS HAVE BMP DETAILS THAT VARY FROM UDFCD STANDARD DETAILS. CONSULT WITH LOCAL JURISDICTIONS AS TO WHICH DETAIL SHOULD BE USED WHEN DIFFERENCES ARE NOTED.

**NOTE:** THE DETAILS INCLUDED WITH THIS FACT SHEET SHOW COMMONLY USED, CONVENTIONAL METHODS OF INLET PROTECTION IN THE DENVER METROPOLITAN AREA. THERE ARE MANY PROPRIETARY INLET PROTECTION METHODS ON THE MARKET. UDFCD NEITHER ENDORSES NOR DISCOURAGES USE OF PROPRIETARY INLET PROTECTION; HOWEVER, IN THE EVENT PROPRIETARY METHODS ARE USED, THE APPROPRIATE DETAIL FROM THE MANUFACTURER MUST BE INCLUDED IN THE SWMP AND THE BMP MUST BE INSTALLED AND MAINTAINED AS SHOWN IN THE MANUFACTURER'S DETAILS.

**NOTE:** SOME MUNICIPALITIES DISCOURAGE OR PROHIBIT THE USE OF STRAW BALES FOR INLET PROTECTION. CHECK WITH LOCAL JURISDICTION TO DETERMINE IF STRAW BALE INLET PROTECTION IS ACCEPTABLE.

IP-3. Rock Sock Inlet Protection for Sump/Area Inlet

IP-4. Silt Fence Inlet Protection for Sump/Area Inlet

IP-5. Over-excavation Inlet Protection

IP-6. Straw Bale Inlet Protection for Sump/Area Inlet

CIP-1. Culvert Inlet Protection

Proprietary inlet protection devices should be installed in accordance with manufacturer specifications.

More information is provided below on selecting inlet protection for sump and on-grade locations.

### **Inlets Located in a Sump**

When applying inlet protection in sump conditions, it is important that the inlet continue to function during larger runoff events. For curb inlets, the maximum height of the protective barrier should be lower than the top of the curb opening to allow overflow into the inlet during larger storms without excessive localized flooding. If the inlet protection height is greater than the curb elevation, particularly if the filter becomes clogged with sediment, runoff will not enter the inlet and may bypass it, possibly causing localized flooding, public safety issues, and downstream erosion and damage from bypassed flows.

Area inlets located in a sump setting can be protected through the use of silt fence, concrete block and rock socks (on paved surfaces), sediment control logs/straw wattles embedded in the adjacent soil and stacked around the area inlet (on pervious surfaces), over-excavation around the inlet, and proprietary products providing equivalent functions.

### **Inlets Located on a Slope**

For curb and gutter inlets on paved sloping streets, block and rock sock inlet protection is recommended in conjunction with curb socks in the gutter leading to the inlet. For inlets located along unpaved roads, also see the Check Dam Fact Sheet.

## **Maintenance and Removal**

Inspect inlet protection frequently. Inspection and maintenance guidance includes:

- Inspect for tears that can result in sediment directly entering the inlet, as well as result in the contents of the BMP (e.g., gravel) washing into the inlet.
- Check for improper installation resulting in untreated flows bypassing the BMP and directly entering the inlet or bypassing to an unprotected downstream inlet. For example, silt fence that has not been properly trenched around the inlet can result in flows under the silt fence and directly into the inlet.
- Look for displaced BMPs that are no longer protecting the inlet. Displacement may occur following larger storm events that wash away or reposition the inlet protection. Traffic or equipment may also crush or displace the BMP.
- Monitor sediment accumulation upgradient of the inlet protection.

- Remove sediment accumulation from the area upstream of the inlet protection, as needed to maintain BMP effectiveness, typically when it reaches no more than half the storage capacity of the inlet protection. For silt fence, remove sediment when it accumulates to a depth of no more than 6 inches. Remove sediment accumulation from the area upstream of the inlet protection as needed to maintain the functionality of the BMP.
- Proprietary inlet protection devices should be inspected and maintained in accordance with manufacturer specifications. If proprietary inlet insert devices are used, sediment should be removed in a timely manner to prevent devices from breaking and spilling sediment into the storm drain.

Inlet protection must be removed and properly disposed of when the drainage area for the inlet has reached final stabilization.



## Description

Concrete waste management involves designating and properly managing a specific area of the construction site as a concrete washout area. A concrete washout area can be created using one of several approaches designed to receive wash water from washing of tools and concrete mixer chutes, liquid concrete waste from dump trucks, mobile batch mixers, or pump trucks. Three basic approaches are available: excavation of a pit in the ground, use of an above ground storage area, or use of prefabricated haul-away concrete washout containers. Surface discharges of concrete washout water from construction sites are prohibited.



**Photograph CWA-1.** Example of concrete washout area. Note gravel tracking pad for access and sign.

## Appropriate Uses

Concrete washout areas must be designated on all sites that will generate concrete wash water or liquid concrete waste from onsite concrete mixing or concrete delivery.

Because pH is a pollutant of concern for washout activities, when unlined pits are used for concrete washout, the soil must have adequate buffering capacity to result in protection of state groundwater standards; otherwise, a liner/containment must be used. The following management practices are recommended to prevent an impact from unlined pits to groundwater:

- The use of the washout site should be temporary (less than 1 year), and
- The washout site should be not be located in an area where shallow groundwater may be present, such as near natural drainages, springs, or wetlands.

## Design and Installation

Concrete washout activities must be conducted in a manner that does not contribute pollutants to surface waters or stormwater runoff. Concrete washout areas may be lined or unlined excavated pits in the ground, commercially manufactured prefabricated washout containers, or aboveground holding areas constructed of berms, sandbags or straw bales with a plastic liner.

Although unlined washout areas may be used, lined pits may be required to protect groundwater under certain conditions.

**Do not locate an unlined washout area within 400 feet of any natural drainage pathway or waterbody or within 1,000 feet of any wells or drinking water sources.** Even for lined concrete washouts, it is advisable to locate the facility away from waterbodies and drainage paths. If site constraints make these

Concrete Washout Area	
<b>Functions</b>	
Erosion Control	No
Sediment Control	No
Site/Material Management	Yes



setbacks infeasible or if highly permeable soils exist in the area, then the pit must be installed with an impermeable liner (16 mil minimum thickness) or surface storage alternatives using prefabricated concrete washout devices or a lined aboveground storage area should be used.

Design details with notes are provided in Detail CWA-1 for pits and CWA-2 for aboveground storage areas. Pre-fabricated concrete washout container information can be obtained from vendors.

## Maintenance and Removal

A key consideration for concrete washout areas is to ensure that adequate signage is in place identifying the location of the washout area. Part of inspecting and maintaining washout areas is ensuring that adequate signage is provided and in good repair and that the washout area is being used, as opposed to washout in non-designated areas of the site.

Remove concrete waste in the washout area, as needed to maintain BMP function (typically when filled to about two-thirds of its capacity). Collect concrete waste and deliver offsite to a designated disposal location.

Upon termination of use of the washout site, accumulated solid waste, including concrete waste and any contaminated soils, must be removed from the site to prevent on-site disposal of solid waste. If the wash water is allowed to evaporate and the concrete hardens, it may be recycled.



**Photograph CWA-2.** Prefabricated concrete washout. Photo courtesy of CDOT.



**Photograph CWA-3.** Earthen concrete washout. Photo courtesy of CDOT.

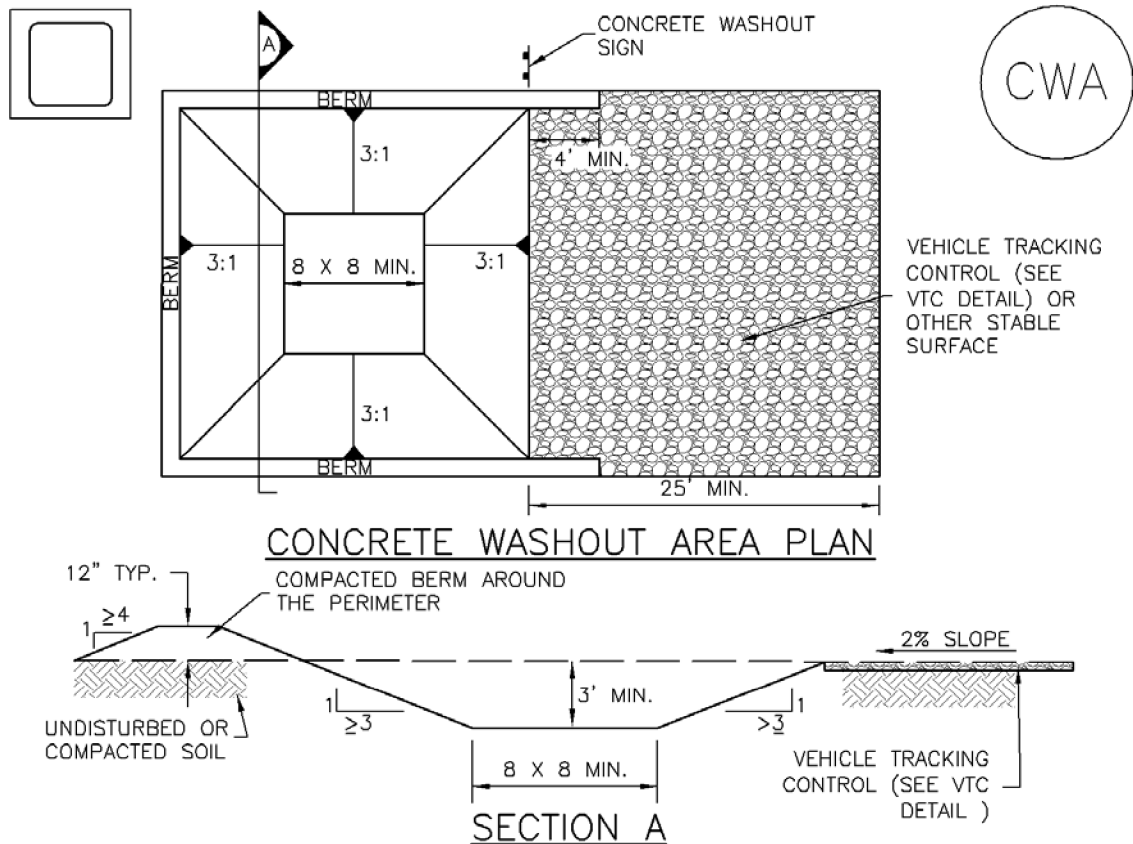

## CWA-1. CONCRETE WASHOUT AREA

### CWA INSTALLATION NOTES

1. SEE PLAN VIEW FOR:  
-CWA INSTALLATION LOCATION.
2. DO NOT LOCATE AN UNLINED CWA WITHIN 400' OF ANY NATURAL DRAINAGE PATHWAY OR WATERBODY. DO NOT LOCATE WITHIN 1,000' OF ANY WELLS OR DRINKING WATER SOURCES. IF SITE CONSTRAINTS MAKE THIS INFEASIBLE, OR IF HIGHLY PERMEABLE SOILS EXIST ON SITE, THE CWA MUST BE INSTALLED WITH AN IMPERMEABLE LINER (16 MIL MIN. THICKNESS) OR SURFACE STORAGE ALTERNATIVES USING PREFABRICATED CONCRETE WASHOUT DEVICES OR A LINED ABOVE GROUND STORAGE ARE SHOULD BE USED.
3. THE CWA SHALL BE INSTALLED PRIOR TO CONCRETE PLACEMENT ON SITE.
4. CWA SHALL INCLUDE A FLAT SUBSURFACE PIT THAT IS AT LEAST 8' BY 8' SLOPES LEADING OUT OF THE SUBSURFACE PIT SHALL BE 3:1 OR FLATTER. THE PIT SHALL BE AT LEAST 3' DEEP.
5. BERM SURROUNDING SIDES AND BACK OF THE CWA SHALL HAVE MINIMUM HEIGHT OF 1'.
6. VEHICLE TRACKING PAD SHALL BE SLOPED 2% TOWARDS THE CWA.
7. SIGNS SHALL BE PLACED AT THE CONSTRUCTION ENTRANCE, AT THE CWA, AND ELSEWHERE AS NECESSARY TO CLEARLY INDICATE THE LOCATION OF THE CWA TO OPERATORS OF CONCRETE TRUCKS AND PUMP RIGS.
8. USE EXCAVATED MATERIAL FOR PERIMETER BERM CONSTRUCTION.

CWA MAINTENANCE NOTES

1. INSPECT BMPs EACH WORKDAY, AND MAINTAIN THEM IN EFFECTIVE OPERATING CONDITION. MAINTENANCE OF BMPs SHOULD BE PROACTIVE, NOT REACTIVE. INSPECT BMPs AS SOON AS POSSIBLE (AND ALWAYS WITHIN 24 HOURS) FOLLOWING A STORM THAT CAUSES SURFACE EROSION, AND PERFORM NECESSARY MAINTENANCE.

2. FREQUENT OBSERVATIONS AND MAINTENANCE ARE NECESSARY TO MAINTAIN BMPs IN EFFECTIVE OPERATING CONDITION. INSPECTIONS AND CORRECTIVE MEASURES SHOULD BE DOCUMENTED THOROUGHLY.

3. WHERE BMPs HAVE FAILED, REPAIR OR REPLACEMENT SHOULD BE INITIATED UPON DISCOVERY OF THE FAILURE.

4. THE CWA SHALL BE REPAIRED, CLEANED, OR ENLARGED AS NECESSARY TO MAINTAIN CAPACITY FOR CONCRETE WASTE. CONCRETE MATERIALS, ACCUMULATED IN PIT, SHALL BE REMOVED ONCE THE MATERIALS HAVE REACHED A DEPTH OF 2'.

5. CONCRETE WASHOUT WATER, WASTED PIECES OF CONCRETE AND ALL OTHER DEBRIS IN THE SUBSURFACE PIT SHALL BE TRANSPORTED FROM THE JOB SITE IN A WATER-TIGHT CONTAINER AND DISPOSED OF PROPERLY.

6. THE CWA SHALL REMAIN IN PLACE UNTIL ALL CONCRETE FOR THE PROJECT IS PLACED.

7. WHEN THE CWA IS REMOVED, COVER THE DISTURBED AREA WITH TOP SOIL, SEED AND MULCH OR OTHERWISE STABILIZED IN A MANNER APPROVED BY THE LOCAL JURISDICTION.

(DETAIL ADAPTED FROM DOUGLAS COUNTY, COLORADO AND THE CITY OF PARKER, COLORADO, NOT AVAILABLE IN AUTOCAD).

NOTE: MANY JURISDICTIONS HAVE BMP DETAILS THAT VARY FROM UDFCD STANDARD DETAILS. CONSULT WITH LOCAL JURISDICTIONS AS TO WHICH DETAIL SHOULD BE USED WHEN DIFFERENCES ARE NOTED.

## Description

A sediment basin is a temporary pond built on a construction site to capture eroded or disturbed soil transported in storm runoff prior to discharge from the site. Sediment basins are designed to capture site runoff and slowly release it to allow time for settling of sediment prior to discharge. Sediment basins are often constructed in locations that will later be modified to serve as post-construction stormwater basins.



**Photograph SB-1.** Sediment basin at the toe of a slope. Photo courtesy of WWE.

## Appropriate Uses

Most large construction sites (typically greater than 2 acres) will require one or more sediment basins for effective management of construction site runoff. On linear construction projects, sediment basins may be impractical; instead, sediment traps or other combinations of BMPs may be more appropriate.

Sediment basins should not be used as stand-alone sediment controls. Erosion and other sediment controls should also be implemented upstream.

When feasible, the sediment basin should be installed in the same location where a permanent post-construction detention pond will be located.

## Design and Installation

The design procedure for a sediment basin includes these steps:

- **Basin Storage Volume:** Provide a storage volume of at least 3,600 cubic feet per acre of drainage area. To the extent practical, undisturbed and/or off-site areas should be diverted around sediment basins to prevent “clean” runoff from mixing with runoff from disturbed areas. For undisturbed areas (both on-site and off-site) that cannot be diverted around the sediment basin, provide a minimum of 500 ft<sup>3</sup>/acre of storage for undeveloped (but stable) off-site areas in addition to the 3,600 ft<sup>3</sup>/acre for disturbed areas. For stable, developed areas that cannot be diverted around the sediment basin, storage volume requirements are summarized in Table SB-1.
- **Basin Geometry:** Design basin with a minimum length-to-width ratio of 2:1 (L:W). If this cannot be achieved because of site space constraints, baffling may be required to extend the effective distance between the inflow point(s) and the outlet to minimize short-circuiting.
- **Dam Embankment:** It is recommended that embankment slopes be 4:1 (H:V) or flatter and no steeper than 3:1 (H:V) in any location.

Sediment Basins	
Functions	
Erosion Control	No
Sediment Control	Yes
Site/Material Management	No

- **Inflow Structure:** For concentrated flow entering the basin, provide energy dissipation at the point of inflow.

**Table SB-1. Additional Volume Requirements for Undisturbed and Developed Tributary Areas Draining through Sediment Basins**

Imperviousness (%)	Additional Storage Volume (ft <sup>3</sup> ) Per Acre of Tributary Area
Undeveloped	500
10	800
20	1230
30	1600
40	2030
50	2470
60	2980
70	3560
80	4360
90	5300
100	6460

- **Outlet Works:** The outlet pipe shall extend through the embankment at a minimum slope of 0.5 percent. Outlet works can be designed using one of the following approaches:
  - **Riser Pipe (Simplified Detail):** Detail SB-1 provides a simplified design for basins treating no more than 15 acres.
  - **Orifice Plate or Riser Pipe:** Follow the design criteria for Full Spectrum Detention outlets in the EDB Fact Sheet provided in Chapter 4 of this manual for sizing of outlet perforations with an emptying time of approximately 72 hours. In lieu of the trash rack, pack uniformly sized 1½ - to 2-inch gravel in front of the plate or surrounding the riser pipe. This gravel will need to be cleaned out frequently during the construction period as sediment accumulates within it. The gravel pack will need to be removed and disposed of following construction to reclaim the basin for use as a permanent detention facility. If the basin will be used as a permanent extended detention basin for the site, a trash rack will need to be installed once contributing drainage areas have been stabilized and the gravel pack and accumulated sediment have been removed.
  - **Floating Skimmer:** If a floating skimmer is used, install it using manufacturer’s recommendations. Illustration SB-1 provides an illustration of a Faircloth Skimmer Floating Outlet™, one of the more commonly used floating skimmer outlets. A skimmer should be designed to release the design volume in no less than 48 hours. The use of a floating skimmer outlet can increase the sediment capture efficiency of a basin significantly. A floating outlet continually decants cleanest water off the surface of the pond and releases cleaner water than would discharge from a perforated riser pipe or plate.

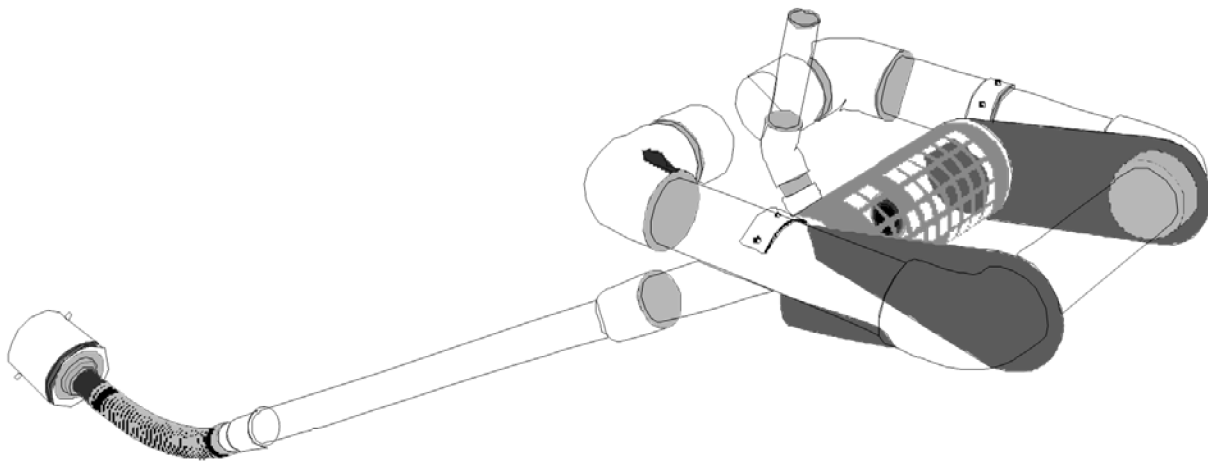

**Illustration SB-1.** Outlet structure for a temporary sediment basin - Faircloth Skimmer Floating Outlet. Illustration courtesy of J. W. Faircloth & Sons, Inc., FairclothSkimmer.com.

- **Outlet Protection and Spillway:** Consider all flow paths for runoff leaving the basin, including protection at the typical point of discharge as well as overtopping.
  - **Outlet Protection:** Outlet protection should be provided where the velocity of flow will exceed the maximum permissible velocity of the material of the waterway into which discharge occurs. This may require the use of a riprap apron at the outlet location and/or other measures to keep the waterway from eroding.
  - **Emergency Spillway:** Provide a stabilized emergency overflow spillway for rainstorms that exceed the capacity of the sediment basin volume and its outlet. Protect basin embankments from erosion and overtopping. If the sediment basin will be converted to a permanent detention basin, design and construct the emergency spillway(s) as required for the permanent facility. If the sediment basin will not become a permanent detention basin, it may be possible to substitute a heavy polyvinyl membrane or properly bedded rock cover to line the spillway and downstream embankment, depending on the height, slope, and width of the embankments.

## Maintenance and Removal

Maintenance activities include the following:

- Dredge sediment from the basin, as needed to maintain BMP effectiveness, typically when the design storage volume is no more than one-third filled with sediment.
- Inspect the sediment basin embankments for stability and seepage.
- Inspect the inlet and outlet of the basin, repair damage, and remove debris. Remove, clean and replace the gravel around the outlet on a regular basis to remove the accumulated sediment within it and keep the outlet functioning.
- Be aware that removal of a sediment basin may require dewatering and associated permit requirements.
- Do not remove a sediment basin until the upstream area has been stabilized with vegetation.

Final disposition of the sediment basin depends on whether the basin will be converted to a permanent post-construction stormwater basin or whether the basin area will be returned to grade. For basins being converted to permanent detention basins, remove accumulated sediment and reconfigure the basin and outlet to meet the requirements of the final design for the detention facility. If the sediment basin is not to be used as a permanent detention facility, fill the excavated area with soil and stabilize with vegetation.

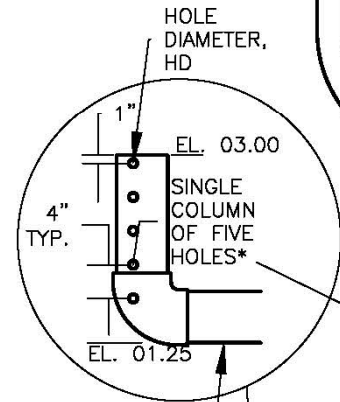
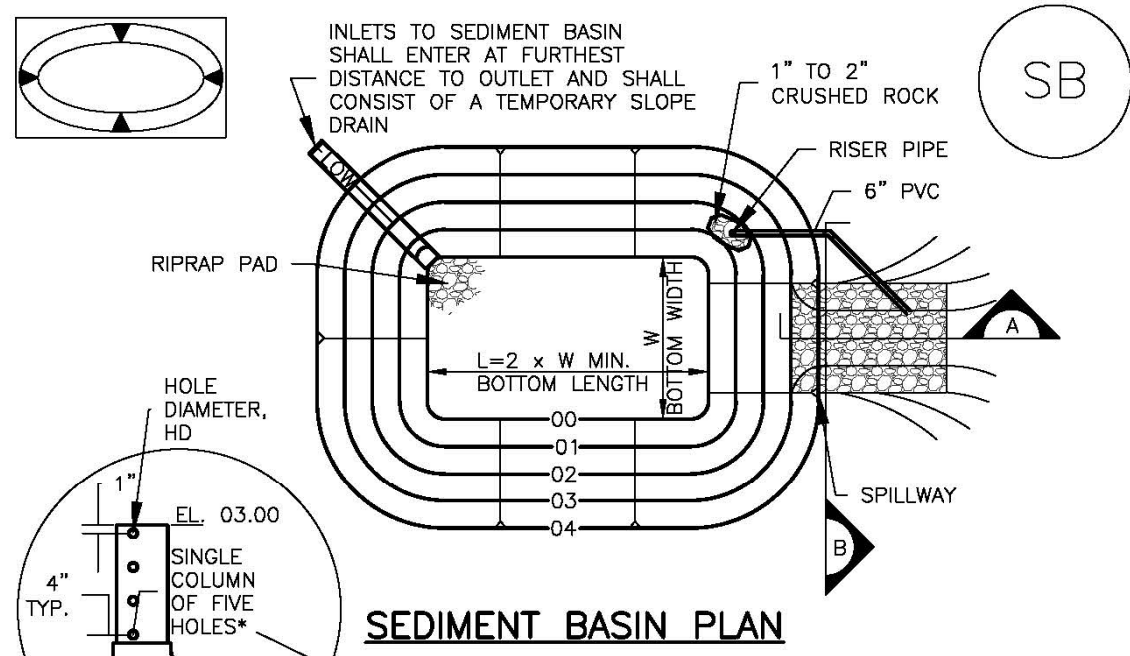

\*EXCEPT WHERE THE HOLES EXCEED 1" DIAMETER, THEN UP TO TWO COLUMNS OF SAME SIZED HOLES MAY BE USED

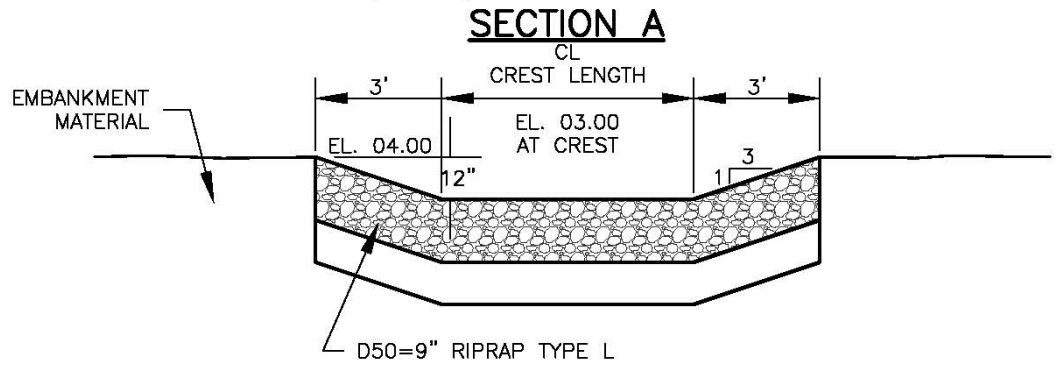
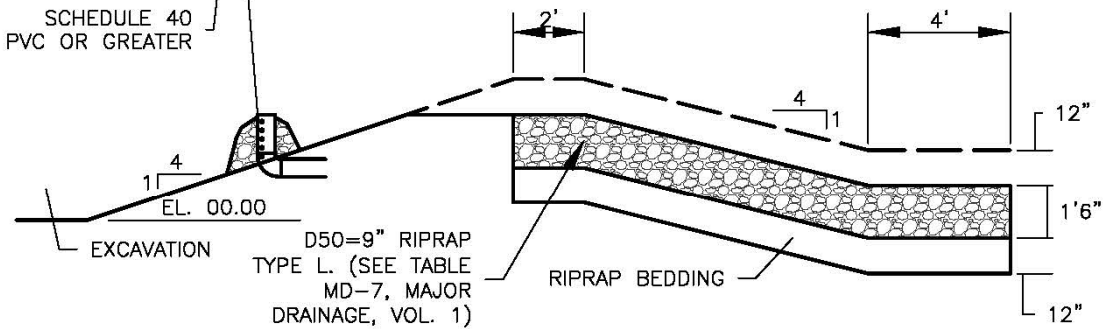



TABLE SB-1. SIZING INFORMATION FOR STANDARD SEDIMENT BASIN			
Upstream Drainage Area (rounded to nearest acre), (ac)	Basin Bottom Width (W), (ft)	Spillway Crest Length (CL), (ft)	Hole Diameter (HD), (in)
1	12 1/2	2	9/32
2	21	3	13/16
3	28	5	1/2
4	33 1/2	6	9/16
5	38 1/2	8	2 1/32
6	43	9	2 1/32
7	47 1/4	11	25/32
8	51	12	27/32
9	55	13	7/8
10	58 1/4	15	15/16
11	61	16	31/32
12	64	18	1
13	67 1/2	19	1 1/16
14	70 1/2	21	1 1/8
15	73 1/4	22	1 3/16

SEDIMENT BASIN INSTALLATION NOTES

1. SEE PLAN VIEW FOR:
  - LOCATION OF SEDIMENT BASIN.
  - TYPE OF BASIN (STANDARD BASIN OR NONSTANDARD BASIN).
  - FOR STANDARD BASIN, BOTTOM WIDTH W, CREST LENGTH CL, AND HOLE DIAMETER, HD.
  - FOR NONSTANDARD BASIN, SEE CONSTRUCTION DRAWINGS FOR DESIGN OF BASIN INCLUDING RISER HEIGHT H, NUMBER OF COLUMNS N, HOLE DIAMETER HD AND PIPE DIAMETER D.
2. FOR STANDARD BASIN, BOTTOM DIMENSION MAY BE MODIFIED AS LONG AS BOTTOM AREA IS NOT REDUCED.
3. SEDIMENT BASINS SHALL BE INSTALLED PRIOR TO ANY OTHER LAND-DISTURBING ACTIVITY THAT RELIES ON ON BASINS AS AS A STORMWATER CONTROL.
4. EMBANKMENT MATERIAL SHALL CONSIST OF SOIL FREE OF DEBRIS, ORGANIC MATERIAL, AND ROCKS OR CONCRETE GREATER THAN 3 INCHES AND SHALL HAVE A MINIMUM OF 15 PERCENT BY WEIGHT PASSING THE NO. 200 SIEVE.
5. EMBANKMENT MATERIAL SHALL BE COMPACTED TO AT LEAST 95 PERCENT OF MAXIMUM DENSITY IN ACCORDANCE WITH ASTM D698.
6. PIPE SCH 40 OR GREATER SHALL BE USED.
7. THE DETAILS SHOWN ON THESE SHEETS PERTAIN TO STANDARD SEDIMENT BASIN(S) FOR DRAINAGE AREAS LESS THAN 15 ACRES. SEE CONSTRUCTION DRAWINGS FOR EMBANKMENT, STORAGE VOLUME, SPILLWAY, OUTLET, AND OUTLET PROTECTION DETAILS FOR ANY SEDIMENT BASIN(S) THAT HAVE BEEN INDIVIDUALLY DESIGNED FOR DRAINAGE AREAS LARGER THAN 15 ACRES.

## SEDIMENT BASIN MAINTENANCE NOTES

1. INSPECT BMPs EACH WORKDAY, AND MAINTAIN THEM IN EFFECTIVE OPERATING CONDITION. MAINTENANCE OF BMPs SHOULD BE PROACTIVE, NOT REACTIVE. INSPECT BMPs AS SOON AS POSSIBLE (AND ALWAYS WITHIN 24 HOURS) FOLLOWING A STORM THAT CAUSES SURFACE EROSION, AND PERFORM NECESSARY MAINTENANCE.
2. FREQUENT OBSERVATIONS AND MAINTENANCE ARE NECESSARY TO MAINTAIN BMPs IN EFFECTIVE OPERATING CONDITION. INSPECTIONS AND CORRECTIVE MEASURES SHOULD BE DOCUMENTED THOROUGHLY.
3. WHERE BMPs HAVE FAILED, REPAIR OR REPLACEMENT SHOULD BE INITIATED UPON DISCOVERY OF THE FAILURE.
4. SEDIMENT ACCUMULATED IN BASIN SHALL BE REMOVED AS NEEDED TO MAINTAIN BMP EFFECTIVENESS, TYPICALLY WHEN SEDIMENT DEPTH REACHES ONE FOOT (I.E., TWO FEET BELOW THE SPILLWAY CREST).
5. SEDIMENT BASINS ARE TO REMAIN IN PLACE UNTIL THE UPSTREAM DISTURBED AREA IS STABILIZED AND GRASS COVER IS ACCEPTED BY THE LOCAL JURISDICTION.
6. WHEN SEDIMENT BASINS ARE REMOVED, ALL DISTURBED AREAS SHALL BE COVERED WITH TOPSOIL, SEEDED AND MULCHED OR OTHERWISE STABILIZED AS APPROVED BY LOCAL JURISDICTION.

(DETAILS ADAPTED FROM DOUGLAS COUNTY, COLORADO)

NOTE: MANY JURISDICTIONS HAVE BMP DETAILS THAT VARY FROM UDFCD STANDARD DETAILS. CONSULT WITH LOCAL JURISDICTIONS AS TO WHICH DETAIL SHOULD BE USED WHEN DIFFERENCES ARE NOTED.

## Description

Temporary seeding can be used to stabilize disturbed areas that will be inactive for an extended period. Permanent seeding should be used to stabilize areas at final grade that will not be otherwise stabilized. Effective seeding includes preparation of a seedbed, selection of an appropriate seed mixture, proper planting techniques, and protection of the seeded area with mulch, geotextiles, or other appropriate measures.



**Photograph TS/PS -1.** Equipment used to drill seed. Photo courtesy of Douglas County.

## Appropriate Uses

When the soil surface is disturbed and will remain inactive for an extended period (typically 30 days or longer), proactive stabilization measures should be implemented. If the inactive period is short-lived (on the order of two weeks), techniques such as surface roughening may be appropriate. For longer periods of inactivity, temporary seeding and mulching can provide effective erosion control. Permanent seeding should be used on finished areas that have not been otherwise stabilized.

Typically, local governments have their own seed mixes and timelines for seeding. Check jurisdictional requirements for seeding and temporary stabilization.

## Design and Installation

Effective seeding requires proper seedbed preparation, selection of an appropriate seed mixture, use of appropriate seeding equipment to ensure proper coverage and density, and protection with mulch or fabric until plants are established.

The USDCM Volume 2 *Revegetation* Chapter contains detailed seed mix, soil preparations, and seeding and mulching recommendations that may be referenced to supplement this Fact Sheet.

Drill seeding is the preferred seeding method. Hydroseeding is not recommended except in areas where steep slopes prevent use of drill seeding equipment, and even in these instances it is preferable to hand seed and mulch. Some jurisdictions do not allow hydroseeding or hydromulching.

## Seedbed Preparation

Prior to seeding, ensure that areas to be revegetated have soil conditions capable of supporting vegetation. Overlot grading can result in loss of topsoil, resulting in poor quality subsoils at the ground surface that have low nutrient value, little organic matter content, few soil microorganisms, rooting restrictions, and conditions less conducive to infiltration of precipitation. As a result, it is typically necessary to provide stockpiled topsoil, compost, or other

Temporary and Permanent Seeding	
Functions	
Erosion Control	Yes
Sediment Control	No
Site/Material Management	No

## **EC-2      Temporary and Permanent Seeding (TS/PS)**

---

soil amendments and rototill them into the soil to a depth of 6 inches or more.

Topsoil should be salvaged during grading operations for use and spread on areas to be revegetated later. Topsoil should be viewed as an important resource to be utilized for vegetation establishment, due to its water-holding capacity, structure, texture, organic matter content, biological activity, and nutrient content. The rooting depth of most native grasses in the semi-arid Denver metropolitan area is 6 to 18 inches. At a minimum, the upper 6 inches of topsoil should be stripped, stockpiled, and ultimately respread across areas that will be revegetated.

Where topsoil is not available, subsoils should be amended to provide an appropriate plant-growth medium. Organic matter, such as well digested compost, can be added to improve soil characteristics conducive to plant growth. Other treatments can be used to adjust soil pH conditions when needed. Soil testing, which is typically inexpensive, should be completed to determine and optimize the types and amounts of amendments that are required.

If the disturbed ground surface is compacted, rip or rototill the surface prior to placing topsoil. If adding compost to the existing soil surface, rototilling is necessary. Surface roughening will assist in placement of a stable topsoil layer on steeper slopes, and allow infiltration and root penetration to greater depth.

Prior to seeding, the soil surface should be rough and the seedbed should be firm, but neither too loose nor compacted. The upper layer of soil should be in a condition suitable for seeding at the proper depth and conducive to plant growth. Seed-to-soil contact is the key to good germination.

### **Seed Mix for Temporary Vegetation**

To provide temporary vegetative cover on disturbed areas which will not be paved, built upon, or fully landscaped or worked for an extended period (typically 30 days or more), plant an annual grass appropriate for the time of planting and mulch the planted areas. Annual grasses suitable for the Denver metropolitan area are listed in Table TS/PS-1. These are to be considered only as general recommendations when specific design guidance for a particular site is not available. Local governments typically specify seed mixes appropriate for their jurisdiction.

### **Seed Mix for Permanent Revegetation**

To provide vegetative cover on disturbed areas that have reached final grade, a perennial grass mix should be established. Permanent seeding should be performed promptly (typically within 14 days) after reaching final grade. Each site will have different characteristics and a landscape professional or the local jurisdiction should be contacted to determine the most suitable seed mix for a specific site. In lieu of a specific recommendation, one of the perennial grass mixes appropriate for site conditions and growth season listed in Table TS/PS-2 can be used. The pure live seed (PLS) rates of application recommended in these tables are considered to be absolute minimum rates for seed applied using proper drill-seeding equipment.

If desired for wildlife habitat or landscape diversity, shrubs such as rubber rabbitbrush (*Chrysothamnus nauseosus*), fourwing saltbush (*Atriplex canescens*) and skunkbrush sumac (*Rhus trilobata*) could be added to the upland seedmixes at 0.25, 0.5 and 1 pound PLS/acre, respectively. In riparian zones, planting root stock of such species as American plum (*Prunus americana*), woods rose (*Rosa woodsii*), plains cottonwood (*Populus sargentii*), and willow (*Populus spp.*) may be considered. On non-topsoiled upland sites, a legume such as Ladak alfalfa at 1 pound PLS/acre can be included as a source of nitrogen for perennial grasses.

Seeding dates for the highest success probability of perennial species along the Front Range are generally in the spring from April through early May and in the fall after the first of September until the ground freezes. If the area is irrigated, seeding may occur in summer months, as well. See Table TS/PS-3 for appropriate seeding dates.

**Table TS/PS-1. Minimum Drill Seeding Rates for Various Temporary Annual Grasses**

Species <sup>a</sup> (Common name)	Growth Season <sup>b</sup>	Pounds of Pure Live Seed (PLS)/acre <sup>c</sup>	Planting Depth (inches)
1. Oats	Cool	35 - 50	1 - 2
2. Spring wheat	Cool	25 - 35	1 - 2
3. Spring barley	Cool	25 - 35	1 - 2
4. Annual ryegrass	Cool	10 - 15	½
5. Millet	Warm	3 - 15	½ - ¾
6. Sudangrass	Warm	5-10	½ - ¾
7. Sorghum	Warm	5-10	½ - ¾
8. Winter wheat	Cool	20-35	1 - 2
9. Winter barley	Cool	20-35	1 - 2
10. Winter rye	Cool	20-35	1 - 2
11. Triticale	Cool	25-40	1 - 2

<sup>a</sup> Successful seeding of annual grass resulting in adequate plant growth will usually produce enough dead-plant residue to provide protection from wind and water erosion for an additional year. This assumes that the cover is not disturbed or mowed closer than 8 inches.

Hydraulic seeding may be substituted for drilling only where slopes are steeper than 3:1 or where access limitations exist. When hydraulic seeding is used, hydraulic mulching should be applied as a separate operation, when practical, to prevent the seeds from being encapsulated in the mulch.

<sup>b</sup> See Table TS/PS-3 for seeding dates. Irrigation, if consistently applied, may extend the use of cool season species during the summer months.

<sup>c</sup> Seeding rates should be doubled if seed is broadcast, or increased by 50 percent if done using a Brillion Drill or by hydraulic seeding.

# EC-2 Temporary and Permanent Seeding (TS/PS)

Table TS/PS-2. Minimum Drill Seeding Rates for Perennial Grasses

Common <sup>a</sup> Name	Botanical Name	Growth Season <sup>b</sup>	Growth Form	Seeds/ Pound	Pounds of PLS/acre
<b>Alkali Soil Seed Mix</b>					
Alkali sacaton	<i>Sporobolus airoides</i>	Cool	Bunch	1,750,000	0.25
Basin wildrye	<i>Elymus cinereus</i>	Cool	Bunch	165,000	2.5
Sodar streambank wheatgrass	<i>Agropyron riparium 'Sodar'</i>	Cool	Sod	170,000	2.5
Jose tall wheatgrass	<i>Agropyron elongatum 'Jose'</i>	Cool	Bunch	79,000	7.0
Arriba western wheatgrass	<i>Agropyron smithii 'Arriba'</i>	Cool	Sod	110,000	5.5
<b>Total</b>					<b>17.75</b>
<b>Fertile Loamy Soil Seed Mix</b>					
Ephriam crested wheatgrass	<i>Agropyron cristatum 'Ephriam'</i>	Cool	Sod	175,000	2.0
Dural hard fescue	<i>Festuca ovina 'duriuscula'</i>	Cool	Bunch	565,000	1.0
Lincoln smooth brome	<i>Bromus inermis leys 'Lincoln'</i>	Cool	Sod	130,000	3.0
Sodar streambank wheatgrass	<i>Agropyron riparium 'Sodar'</i>	Cool	Sod	170,000	2.5
Arriba western wheatgrass	<i>Agropyron smithii 'Arriba'</i>	Cool	Sod	110,000	7.0
<b>Total</b>					<b>15.5</b>
<b>High Water Table Soil Seed Mix</b>					
Meadow foxtail	<i>Alopecurus pratensis</i>	Cool	Sod	900,000	0.5
Redtop	<i>Agrostis alba</i>	Warm	Open sod	5,000,000	0.25
Reed canarygrass	<i>Phalaris arundinacea</i>	Cool	Sod	68,000	0.5
Lincoln smooth brome	<i>Bromus inermis leys 'Lincoln'</i>	Cool	Sod	130,000	3.0
Pathfinder switchgrass	<i>Panicum virgatum 'Pathfinder'</i>	Warm	Sod	389,000	1.0
Alkar tall wheatgrass	<i>Agropyron elongatum 'Alkar'</i>	Cool	Bunch	79,000	5.5
<b>Total</b>					<b>10.75</b>
<b>Transition Turf Seed Mix<sup>c</sup></b>					
Ruebens Canadian bluegrass	<i>Poa compressa 'Ruebens'</i>	Cool	Sod	2,500,000	0.5
Dural hard fescue	<i>Festuca ovina 'duriuscula'</i>	Cool	Bunch	565,000	1.0
Citation perennial ryegrass	<i>Lolium perenne 'Citation'</i>	Cool	Sod	247,000	3.0
Lincoln smooth brome	<i>Bromus inermis leys 'Lincoln'</i>	Cool	Sod	130,000	3.0
<b>Total</b>					<b>7.5</b>

**Table TS/PS-2. Minimum Drill Seeding Rates for Perennial Grasses (cont.)**

Common Name	Botanical Name	Growth Season <sup>b</sup>	Growth Form	Seeds/Pound	Pounds of PLS/acre
<b>Sandy Soil Seed Mix</b>					
Blue grama	<i>Bouteloua gracilis</i>	Warm	Sod-forming bunchgrass	825,000	0.5
Camper little bluestem	<i>Schizachyrium scoparium</i> 'Camper'	Warm	Bunch	240,000	1.0
Prairie sandreed	<i>Calamovilfa longifolia</i>	Warm	Open sod	274,000	1.0
Sand dropseed	<i>Sporobolus cryptandrus</i>	Cool	Bunch	5,298,000	0.25
Vaughn sideoats grama	<i>Bouteloua curtipendula</i> 'Vaughn'	Warm	Sod	191,000	2.0
Arriba western wheatgrass	<i>Agropyron smithii</i> 'Arriba'	Cool	Sod	110,000	5.5
<b>Total</b>					<b>10.25</b>
<b>Heavy Clay, Rocky Foothill Seed Mix</b>					
Ephriam crested wheatgrass <sup>d</sup>	<i>Agropyron cristatum</i> 'Ephriam'	Cool	Sod	175,000	1.5
Oahe Intermediate wheatgrass	<i>Agropyron intermedium</i> 'Oahe'	Cool	Sod	115,000	5.5
Vaughn sideoats grama <sup>e</sup>	<i>Bouteloua curtipendula</i> 'Vaughn'	Warm	Sod	191,000	2.0
Lincoln smooth brome	<i>Bromus inermis</i> leys 'Lincoln'	Cool	Sod	130,000	3.0
Arriba western wheatgrass	<i>Agropyron smithii</i> 'Arriba'	Cool	Sod	110,000	5.5
<b>Total</b>					<b>17.5</b>
<p><sup>a</sup> All of the above seeding mixes and rates are based on drill seeding followed by crimped straw mulch. These rates should be doubled if seed is broadcast and should be increased by 50 percent if the seeding is done using a Brillion Drill or is applied through hydraulic seeding. Hydraulic seeding may be substituted for drilling only where slopes are steeper than 3:1. If hydraulic seeding is used, hydraulic mulching should be done as a separate operation.</p> <p><sup>b</sup> See Table TS/PS-3 for seeding dates.</p> <p><sup>c</sup> If site is to be irrigated, the transition turf seed rates should be doubled.</p> <p><sup>d</sup> Crested wheatgrass should not be used on slopes steeper than 6H to 1V.</p> <p><sup>e</sup> Can substitute 0.5 lbs PLS of blue grama for the 2.0 lbs PLS of Vaughn sideoats grama.</p>					

# EC-2 Temporary and Permanent Seeding (TS/PS)

Table TS/PS-3. Seeding Dates for Annual and Perennial Grasses

Seeding Dates	Annual Grasses (Numbers in table reference species in Table TS/PS-1)		Perennial Grasses	
	Warm	Cool	Warm	Cool
January 1–March 15			✓	✓
March 16–April 30	4	1,2,3	✓	✓
May 1–May 15	4		✓	
May 16–June 30	4,5,6,7			
July 1–July 15	5,6,7			
July 16–August 31				
September 1–September 30		8,9,10,11		
October 1–December 31			✓	✓

## Mulch

Cover seeded areas with mulch or an appropriate rolled erosion control product to promote establishment of vegetation. Anchor mulch by crimping, netting or use of a non-toxic tackifier. See the Mulching BMP Fact Sheet for additional guidance.

provide 

## Maintenance and Removal

Monitor and observe seeded areas to identify areas of poor growth or areas that fail to germinate. Reseed and mulch these areas, as needed.

An area that has been permanently seeded should have a good stand of vegetation within one growing season if irrigated and within three growing seasons without irrigation in Colorado. Reseed portions of the site that fail to germinate or remain bare after the first growing season.

Seeded areas may require irrigation, particularly during extended dry periods. Targeted weed control may also be necessary.

Protect seeded areas from construction equipment and vehicle access.



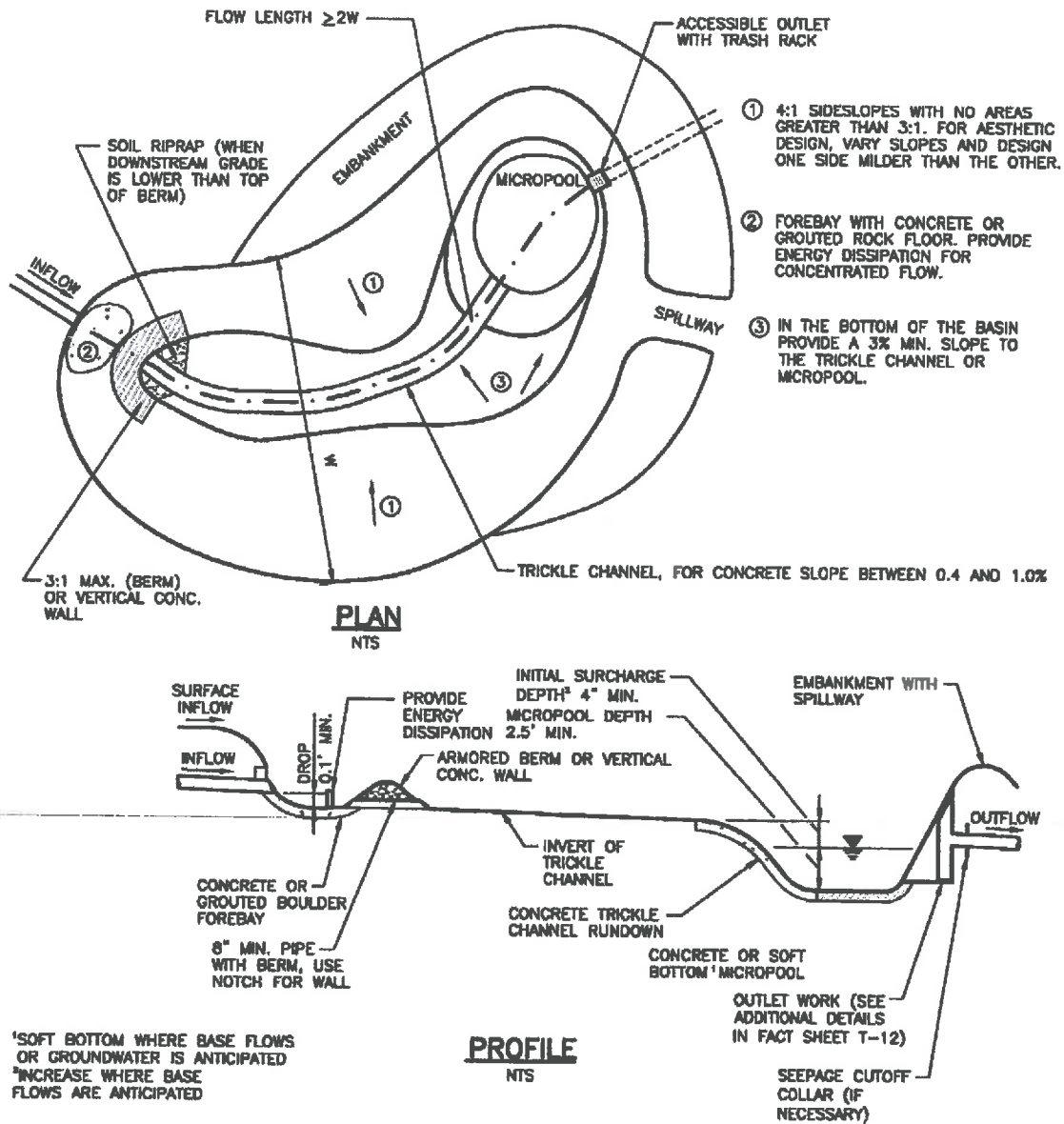

**FIGURE EDB-3**  
**EXTENDED DETENTION BASIN**

**Figure EDB-3. Extended Detention Basin (EDB) Plan and Profile**

Additional Details are provided in BMP Fact Sheet T-12. This includes outlet structure details including orifice plates and trash racks.

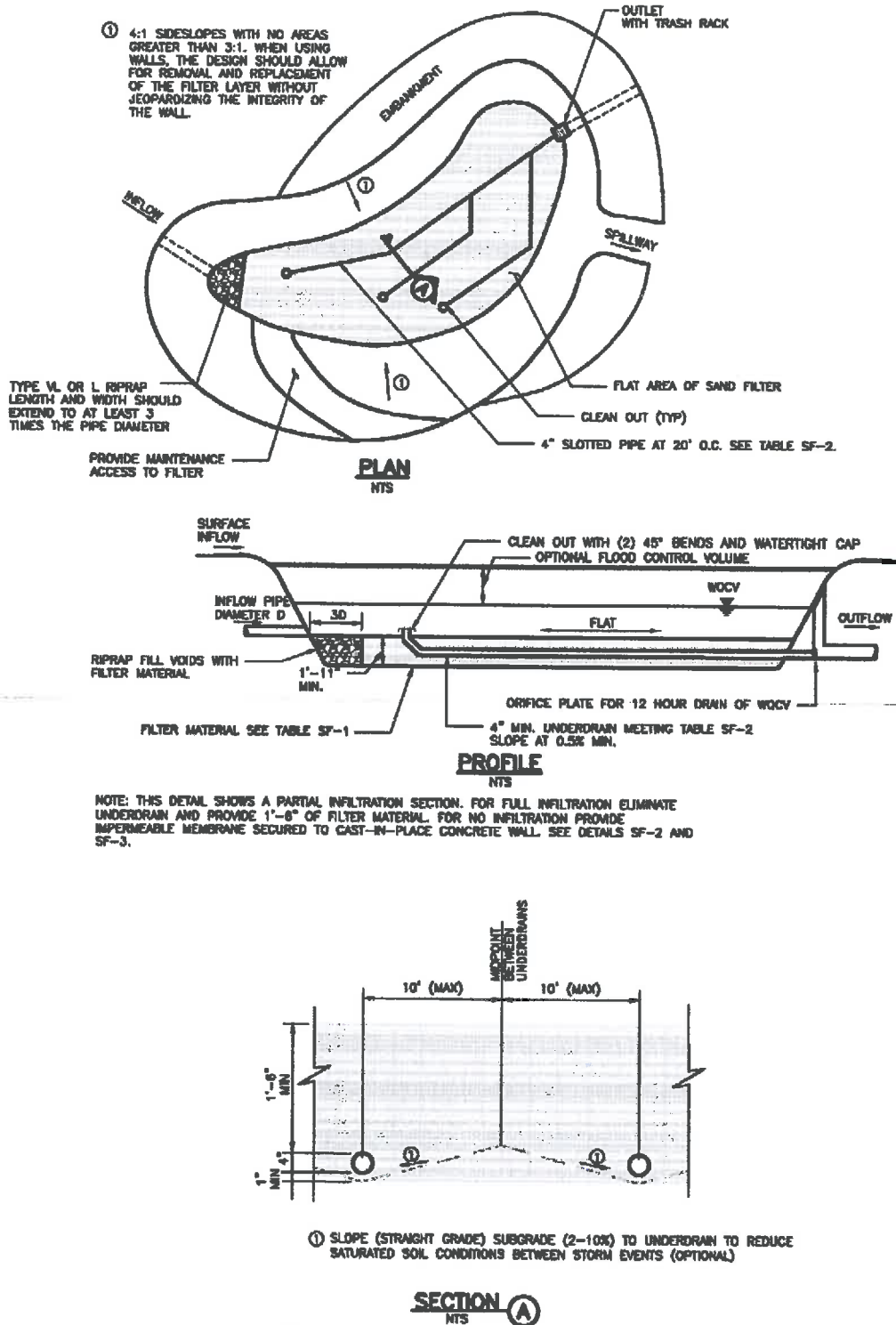

Figure SF-1. Sand Filter Plan and Sections

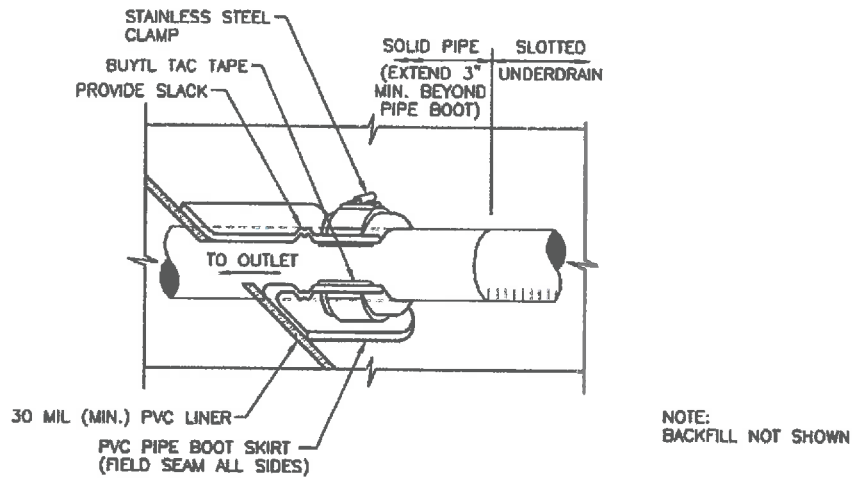

Figure SF-2. Geomembrane Liner/Underdrain Penetration Detail

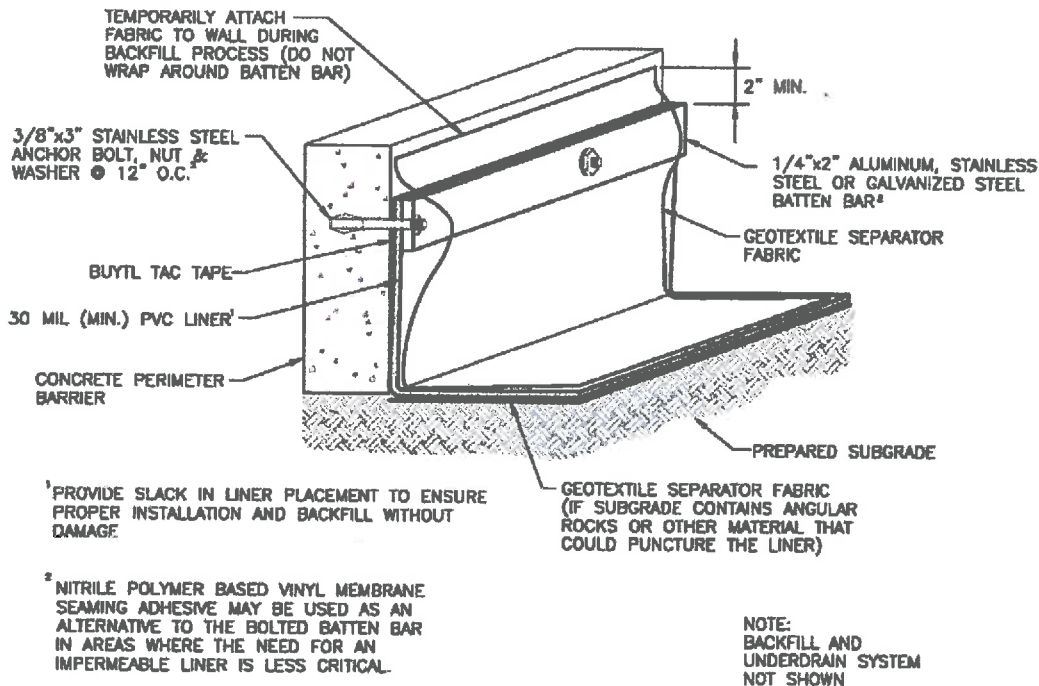

Figure SF-3. Geomembrane Liner/Concrete Connection Detail

SWMP GRADING AND EROSION CONTROL PLANS



**STANDARD CONSTRUCTION NOTES:**

- ALL DRAINAGE AND ROADWAY CONSTRUCTION SHALL MEET THE STANDARDS AND SPECIFICATIONS OF THE CITY OF COLORADO SPRINGS/EL PASO COUNTY DRAINAGE CRITERIA MANUAL VOLUMES 1 AND 2, AND THE EL PASO COUNTY ENGINEERING CRITERIA MANUAL.
- CONTRACTOR SHALL BE RESPONSIBLE FOR THE NOTIFICATION AND FIELD LOCATION OF ALL EXISTING UTILITIES, WHETHER SHOWN ON THE PLANS OR NOT, BEFORE BEGINNING CONSTRUCTION. LOCATION OF EXISTING UTILITIES SHALL BE VERIFIED BY THE CONTRACTOR PRIOR TO CONSTRUCTION. CALL 811 TO CONTACT THE UTILITY NOTIFICATION CENTER OF COLORADO SPRINGS.
- CONTRACTOR SHALL KEEP A COPY OF THESE APPROVED PLANS, THE GRADING AND EROSION CONTROL PLAN, THE STORMWATER MANAGEMENT PLAN (SWMP), THE SOILS AND GEOTECHNICAL REPORT AND THE APPROPRIATE DESIGN AND CONSTRUCTION STANDARDS AND SPECIFICATIONS AT THE JOB SITE AT ALL TIME INCLUDING THE FOLLOWING:
  - EL PASO COUNTY ENGINEERING CRITERIA MANUAL (ECM)
  - CITY OF COLORADO SPRINGS/EL PASO COUNTY ENGINEERING CRITERIA MANUAL VOLUMES 1 AND 2.
  - COLORADO DEPARTMENT OF TRANSPORTATION (CDOT) STANDARDS SPECIFICATION FOR ROAD AND BRIDGE CONSTRUCTION.
  - CDOT M&S STANDARDS.
- IT IS THE DESIGN ENGINEERS RESPONSIBILITY TO ACCURACY SHOW EXISTING CONDITION BOTH ONSITE AND OFFSITE ON THE CONSTRUCTION PLANS. ANY MODIFICATION NECESSARY DUE TO CONFLICT OMISSIONS OR CHANGED CONDITIONS WILL BE ENTIRELY THE DEVELOPERS RESPONSIBILITY TO RECTIFY.
- ONCE THE ESQCP HAS BEEN ISSUED, THE CONTRACTOR MAY INSTALL THE INITIAL STAGE EROSION AND SEDIMENT CONTROL BMPs AS INDICATED ON THE GEC. A PRECONSTRUCTION MEETING BETWEEN THE CONTRACTOR, ENGINEER, AND EL PASO COUNTY WILL BE HELD PRIOR TO ANY CONSTRUCTION. IT IS THE RESPONSIBILITY OF THE APPLICANT TO COORDINATE THE MEETING TIME AND PLACE WITH COUNTY PCD INSPECTIONS STAFF.
- IT IS THE CONTRACTORS RESPONSIBILITY TO UNDERSTAND THE REQUIREMENTS OF ALL JURISDICTIONAL AGENCIES AND TO OBTAIN ALL REQUIRED PERMITS, INCLUDING BUT NOT LIMITED TO EL PASO COUNTY EROSION AND STORM WATER QUALITY CONTROL PERMIT (ESQCP), US ARMY CORPS OF ENGINEER ISSUED 401 AND/OR 404 PERMITS AND COUNTY AND STATE FUGITIVE DUST PERMITS.
- ALL CONSTRUCTION TRAFFIC MUST ENTER/EXIT THE CONSTRUCTION SITE AT APPROVED CONSTRUCTION ACCESS POINTS.
- ANY TEMPORARY SIGNAGE AND STRIPING SHALL COMPLY WITH EL PASO COUNTY DOW AND MUTCD CRITERIA.
- CONTRACTOR SHALL OBTAIN ANY PERMITS REQUIRE BY EL PASO COUNTY DOT INCLUDING WORK WITHIN THE RIGHT-OF-WAY AND SPECIAL TRANSPORT PERMITS.
- THE LIMITS OF CONSTRUCTION SHALL REMAIN WITHIN THE PROPERTY LINE UNLESS OTHERWISE NOTED. THE OWNER/DEVELOPER SHALL OBTAIN WRITTEN PERMISSION AND EASEMENTS, WHERE REQUIRED, FROM ADJOINING PROPERTY OWNER(S) PRIOR TO ANY OFFSITE DISTURBANCE GRADING, OR CONSTRUCTION.

**GRADING AND EROSION CONTROL NOTES:**

- STORMWATER DISCHARGES FROM CONSTRUCTION SITES SHALL NOT CAUSE OR THREATEN TO CAUSE POLLUTION, CONTAMINATION, OR DEGRADATION OF STATE WATERS. ALL WORK AND EARTH DISTURBANCE SHALL BE DONE IN A MANNER THAT MINIMIZES POLLUTION OF ANY ON-SITE OR OFF-SITE WATERS, INCLUDING WETLANDS.
- NOTWITHSTANDING ANYTHING DEPICTED IN THESE PLANS IN WORDS OR GRAPHIC REPRESENTATION, ALL DESIGN AND CONSTRUCTION RELATED TO ROADS, STORM DRAINAGE AND EROSION CONTROL SHALL CONFORM TO THE STANDARDS AND REQUIREMENTS OF THE MOST RECENT VERSION OF THE RELEVANT ADOPTED EL PASO COUNTY STANDARDS, INCLUDING THE LAND DEVELOPMENT CODE, THE ENGINEERING CRITERIA MANUAL, THE DRAINAGE CRITERIA MANUAL, AND THE DRAINAGE CRITERIA MANUAL VOLUME 2. ANY DEVIATIONS FROM REGULATIONS AND STANDARDS MUST BE REQUESTED, AND APPROVED, IN WRITING.
- A SEPARATE STORMWATER MANAGEMENT PLAN (SWMP) FOR THIS PROJECT SHALL BE COMPLETED AND AN EROSION AND STORMWATER QUALITY CONTROL PERMIT (ESQCP) ISSUED PRIOR TO COMMENCING CONSTRUCTION. MANAGEMENT OF THE SWMP DURING CONSTRUCTION IS THE RESPONSIBILITY OF THE DESIGNATED QUALIFIED STORMWATER MANAGER OR CERTIFIED EROSION CONTROL INSPECTOR. THE SWMP SHALL BE LOCATED ON SITE AT ALL TIMES DURING CONSTRUCTION AND SHALL BE KEPT UP TO DATE WITH WORK PROGRESS AND CHANGES IN THE FIELD.
- ONCE THE ESQCP IS APPROVED AND A NOTICE TO PROCEED HAS BEEN ISSUED, THE CONTRACTOR MAY INSTALL THE INITIAL STAGE EROSION AND SEDIMENT CONTROL MEASURES AS INDICATED ON THE APPROVED GEC. A PRECONSTRUCTION MEETING BETWEEN THE CONTRACTOR, ENGINEER, AND EL PASO COUNTY WILL BE HELD PRIOR TO ANY CONSTRUCTION. IT IS THE RESPONSIBILITY OF THE APPLICANT TO COORDINATE THE MEETING TIME AND PLACE WITH COUNTY STAFF.
- CONTROL MEASURES MUST BE INSTALLED PRIOR TO COMMENCEMENT OF ACTIVITIES THAT COULD CONTRIBUTE POLLUTANTS TO STORMWATER. CONTROL MEASURES FOR ALL SLOPES, CHANNELS, DITCHES, AND DISTURBED LAND AREAS SHALL BE INSTALLED IMMEDIATELY UPON COMPLETION OF THE DISTURBANCE.
- ALL TEMPORARY SEDIMENT AND EROSION CONTROL MEASURES SHALL BE MAINTAINED AND REMAIN IN EFFECTIVE OPERATING CONDITION UNTIL PERMANENT SOIL EROSION CONTROL MEASURES ARE IMPLEMENTED AND FINAL STABILIZATION IS ESTABLISHED. ALL PERSONS ENGAGED IN LAND DISTURBANCE ACTIVITIES SHALL ASSESS THE ADEQUACY OF CONTROL MEASURES AT THE SITE AND IDENTIFY IF CHANGES TO THOSE CONTROL MEASURES ARE NEEDED TO ENSURE THE CONTINUED EFFECTIVE PERFORMANCE OF THE CONTROL MEASURES. ALL CHANGES TO TEMPORARY SEDIMENT AND EROSION CONTROL MEASURES MUST BE INCORPORATED INTO THE STORMWATER MANAGEMENT PLAN.
- TEMPORARY STABILIZATION SHALL BE IMPLEMENTED ON DISTURBED AREAS AND STOCKPILES WHERE GROUND DISTURBING CONSTRUCTION ACTIVITY HAS PERMANENTLY CEASED OR TEMPORARILY CEASED FOR LONGER THAN 14 DAYS.
- FINAL STABILIZATION MUST BE IMPLEMENTED AT ALL APPLICABLE CONSTRUCTION SITES. FINAL STABILIZATION IS ACHIEVED WHEN ALL GROUND DISTURBING ACTIVITIES ARE COMPLETE AND ALL DISTURBED AREAS EITHER HAVE A UNIFORM VEGETATIVE COVER WITH INDIVIDUAL PLANT DENSITY OF 70 PERCENT OF PRE-DISTURBANCE LEVELS ESTABLISHED OR EQUIVALENT PERMANENT ALTERNATIVE STABILIZATION METHOD IS IMPLEMENTED. ALL TEMPORARY SEDIMENT AND EROSION CONTROL MEASURES SHALL BE REMOVED UPON FINAL STABILIZATION AND BEFORE PERMIT CLOSURE.
- ALL PERMANENT STORMWATER MANAGEMENT FACILITIES SHALL BE INSTALLED AS DESIGNED IN THE APPROVED PLANS. ANY PROPOSED CHANGES THAT EFFECT THE DESIGN OR FUNCTION OF PERMANENT STORMWATER MANAGEMENT STRUCTURES MUST BE APPROVED BY THE ECM ADMINISTRATOR PRIOR TO IMPLEMENTATION.
- EARTH DISTURBANCES SHALL BE CONDUCTED IN SUCH A MANNER SO AS TO EFFECTIVELY MINIMIZE ACCELERATED SOIL EROSION AND RESULTING SEDIMENTATION. ALL DISTURBANCES SHALL BE DESIGNED, CONSTRUCTED, AND COMPLETED SO THAT THE EXPOSED AREA OF ANY DISTURBED LAND SHALL BE LIMITED TO THE SHORTEST PRACTICAL PERIOD OF TIME. PRE-EXISTING VEGETATION SHALL BE PROTECTED AND MAINTAINED WITHIN 50 HORIZONTAL FEET OF A WATERS OF THE STATE, UNLESS SHOWN TO BE INFEASIBLE AND SPECIFICALLY REJECTED AND APPROVED.
- COMPACTION OF SOIL MUST BE PREVENTED IN AREAS DESIGNATED FOR INFILTRATION CONTROL MEASURES OR WHERE FINAL STABILIZATION WILL BE ACHIEVED BY VEGETATION DESIGNATED FOR INFILTRATION CONTROL MEASURES SHALL ALSO BE PROTECTED FROM SEDIMENTATION DURING CONSTRUCTION UNTIL FINAL STABILIZATION IS ACHIEVED. IF COMPACTION PREVENTION IS NOT FEASIBLE DUE TO SITE CONSTRAINTS, ALL AREAS DESIGNATED FOR INFILTRATION AND VEGETATION CONTROL MEASURES MUST BE LOOSENEED PRIOR TO INSTALLATION OF THE CONTROL MEASURE(S).
- ANY TEMPORARY OR PERMANENT FACILITY DESIGNED AND CONSTRUCTED FOR THE CONVEYANCE OF STORMWATER AROUND, THROUGH, OR FROM THE EARTH DISTURBANCE AREA SHALL BE A STABILIZED CONVEYANCE DESIGNED TO MINIMIZE EROSION AND THE DISCHARGE OF SEDIMENT OFF SITE.
- CONCRETE WASH WATER SHALL BE CONTAINED AND DISPOSED OF IN ACCORDANCE WITH THE SWMP. NO WASH WATER SHALL BE DISCHARGED TO OR ALLOWED TO ENTER STATE WATERS, INCLUDING ANY SURFACE OR SUBSURFACE STORM DRAINAGE SYSTEM OR FACILITIES. CONCRETE WASHOUTS SHALL NOT BE LOCATED IN AN AREA WHERE SHALLOW GROUNDWATER MAY BE PRESENT, OR WITHIN 50 FEET OF A SURFACE WATER BODY, CREEK OR STREAM.
- DURING DEWATERING OPERATIONS OF UNCONTAMINATED GROUND WATER MAY BE DISCHARGED ON SITE, BUT SHALL NOT LEAVE THE SITE IN THE FORM OF SURFACE RUNOFF UNLESS AN APPROVED STATE DEWATERING PERMIT IS IN PLACE.
- EROSION CONTROL BLANKETING OR OTHER PROTECTIVE COVERING SHALL BE USED ON SLOPES STEEPER THAN 3:1.
- CONTRACTOR SHALL BE RESPONSIBLE FOR THE REMOVAL OF ALL WASTES FROM THE CONSTRUCTION SITE FOR DISPOSAL IN ACCORDANCE WITH LOCAL AND STATE REGULATORY REQUIREMENTS. NO CONSTRUCTION DEBRIS, TREE SLASH, BUILDING MATERIAL WASTES OR UNUSED BUILDING MATERIALS SHALL BE BURIED, DUMPED, OR DISCHARGED AT THE SITE.
- WASTE MATERIALS SHALL NOT BE TEMPORARILY PLACED OR STORED IN THE STREET, ALLEY, OR OTHER PUBLIC WAY, UNLESS IN ACCORDANCE WITH AN APPROVED TRAFFIC CONTROL PLAN. CONTROL MEASURES MAY BE REQUIRED BY EL PASO COUNTY ENGINEERING IF DEEMED NECESSARY, BASED ON SPECIFIC CONDITIONS AND CIRCUMSTANCES.
- TRACKING OF SOILS AND CONSTRUCTION DEBRIS OFF-SITE SHALL BE MINIMIZED. MATERIALS TRACKED OFF-SITE SHALL BE CLEANED UP AND PROPERLY DISPOSED OF IMMEDIATELY.
- THE OWNER/DEVELOPER SHALL BE RESPONSIBLE FOR THE REMOVAL OF ALL CONSTRUCTION DEBRIS, DIRT, TRASH, ROCK, SEDIMENT, SOIL, AND SAND THAT MAY ACCUMULATE IN ROADS, STORM DRAINS AND OTHER DRAINAGE CONVEYANCE SYSTEMS AND STORMWATER APPURTENANCES AS A RESULT OF SITE DEVELOPMENT.
- THE QUANTITY OF MATERIALS STORED ON THE PROJECT SITE SHALL BE LIMITED, AS MUCH AS PRACTICAL, TO THAT QUANTITY REQUIRED TO PERFORM THE WORK IN AN ORDERLY SEQUENCE. ALL MATERIALS STORED ON-SITE SHALL BE STORED IN A NEAT, ORDERLY MANNER, IN THEIR ORIGINAL CONTAINERS, WITH ORIGINAL MANUFACTURER'S LABELS.
- NO CHEMICAL(S) HAVING THE POTENTIAL TO BE RELEASED IN STORMWATER ARE TO BE STORED OR USED ONSITE UNLESS PERMISSION FOR THE USE OF SUCH CHEMICAL(S) IS GRANTED IN WRITING BY THE ECM ADMINISTRATOR. IN GRANTING APPROVAL FOR THE USE OF SUCH CHEMICAL(S), SPECIAL CONDITIONS AND MONITORING MAY BE REQUIRED.
- BULK STORAGE OF ALLOWED PETROLEUM PRODUCTS OR OTHER ALLOWED LIQUID CHEMICALS IN EXCESS OF 55 GALLONS SHALL REQUIRE ADEQUATE SECONDARY CONTAINMENT PROTECTION TO CONTAIN ALL SPILLS ONSITE AND TO PREVENT ANY SPILLED MATERIALS FROM ENTERING STATE WATERS, ANY SURFACE OR SUBSURFACE STORM DRAINAGE SYSTEM OR OTHER FACILITIES.
- NO PERSON SHALL CAUSE THE IMPEDIMENT OF STORMWATER FLOW IN THE CURB AND GUTTER OR DITCH EXCEPT WITH APPROVED SEDIMENT CONTROL MEASURES.
- OWNER/DEVELOPER AND THEIR AGENTS SHALL COMPLY WITH THE "COLORADO WATER QUALITY CONTROL ACT" (TITLE 25, ARTICLE 8, CRS), AND THE "CLEAN WATER ACT" (33 USC 1344), IN ADDITION TO THE REQUIREMENTS OF THE LAND DEVELOPMENT CODE, DCM VOLUME II AND THE ECM APPENDIX I. ALL APPROPRIATE PERMITS MUST BE OBTAINED BY THE CONTRACTOR PRIOR TO CONSTRUCTION (1041, NPDES, FLOODPLAIN, 404, FUGITIVE DUST, ETC.). IN THE EVENT OF CONFLICTS BETWEEN THESE REQUIREMENTS AND OTHER LAWS, RULES, OR REGULATIONS OF OTHER FEDERAL, STATE, LOCAL, OR COUNTY AGENCIES, THE MOST RESTRICTIVE LAWS, RULES, OR REGULATIONS SHALL APPLY.
- ALL CONSTRUCTION TRAFFIC MUST ENTER/EXIT THE SITE ONLY AT APPROVED CONSTRUCTION ACCESS POINTS.
- PRIOR TO CONSTRUCTION THE PERMITTEE SHALL VERIFY THE LOCATION OF EXISTING UTILITIES.
- A WATER SOURCE SHALL BE AVAILABLE ON SITE DURING EARTHWORK OPERATIONS AND SHALL BE UTILIZED AS REQUIRED TO MINIMIZE DUST FROM EARTHWORK EQUIPMENT AND WIND.
- THE SOILS REPORT FOR THIS SITE HAS BEEN PREPARED BY CTL THOMPSON, INC., AND SHALL BE CONSIDERED A PART OF THESE PLANS.
- AT LEAST TEN (10) DAYS PRIOR TO THE ANTICIPATED START OF CONSTRUCTION, FOR PROJECTS THAT WILL DISTURB ONE (1) ACRE OR MORE, THE OWNER OR OPERATOR OF CONSTRUCTION ACTIVITY SHALL SUBMIT A PERMIT APPLICATION FOR STORMWATER DISCHARGE TO THE COLORADO DEPARTMENT OF PUBLIC HEALTH AND ENVIRONMENT, WATER QUALITY DIVISION. THE APPLICATION CONTAINS CERTIFICATION OF COMPLETION OF A STORMWATER MANAGEMENT PLAN (SWMP), OF WHICH THIS GRADING AND EROSION CONTROL PLAN MAY BE A PART. FOR INFORMATION OR APPLICATION MATERIALS CONTACT:

COLORADO DEPARTMENT OF PUBLIC HEALTH AND ENVIRONMENT  
 WATER QUALITY CONTROL DIVISION  
 WOOD - PERMITS  
 4300 CHERRY CREEK DRIVE SOUTH  
 DENVER, CO 80248-1530  
 ATTN: PERMITS UNIT

# HOMESTEAD AT STERLING RANCH FILING NO. 2

## COUNTY OF EL PASO, STATE OF COLORADO

# FINAL GRADING/EROSION CONTROL PLANS

MARCH 2020  
 SF-19-004

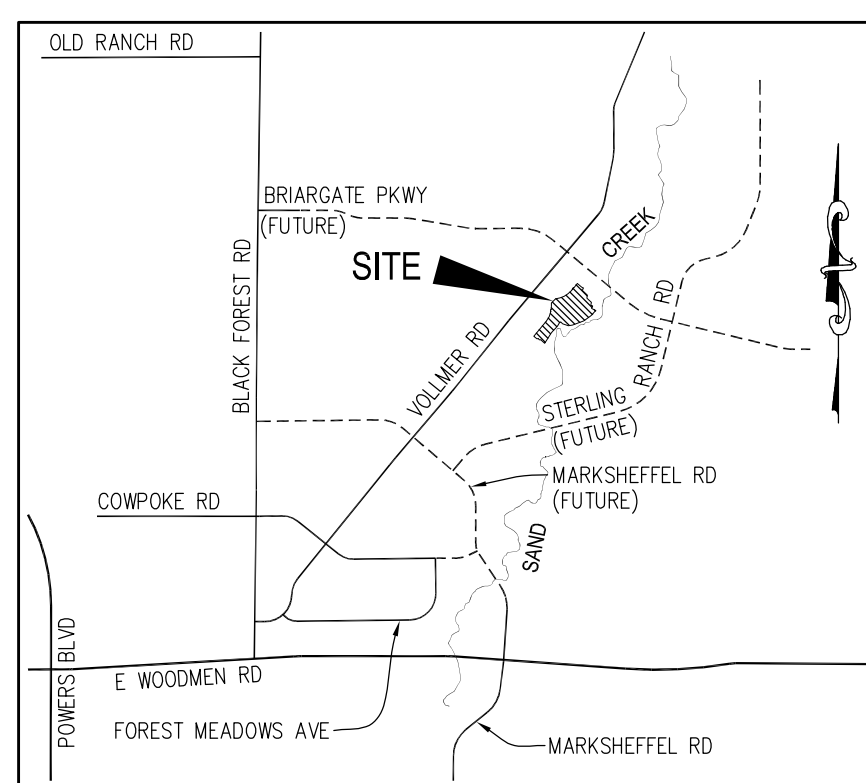

VICINITY MAP  
 N.T.S.

FOR CONSTRUCTION DRAWINGS AND DETAILS; SEE SAND CREEK BANK STABILIZATION PLAN, & STORM SEWERS PLANS FOR HOMESTEAD AT STERLING RANCH FILING NO. 2. BY M&S CIVIL CONSULTANTS, INC.

SAND CREEK CHANNEL IMPROVEMENTS PLANS ARE FORTHCOMING PROVIDED BY KIOWA ENGINEERING. THESE PLANS WILL DEPICT THE IMPROVEMENTS TO SAND CREEK CHANNEL, THE FINAL TRAIL LOCATION AND MAINTENANCE ACCESS LOCATIONS FOR THE SAND CREEK DRAINAGE STRUCTURES.

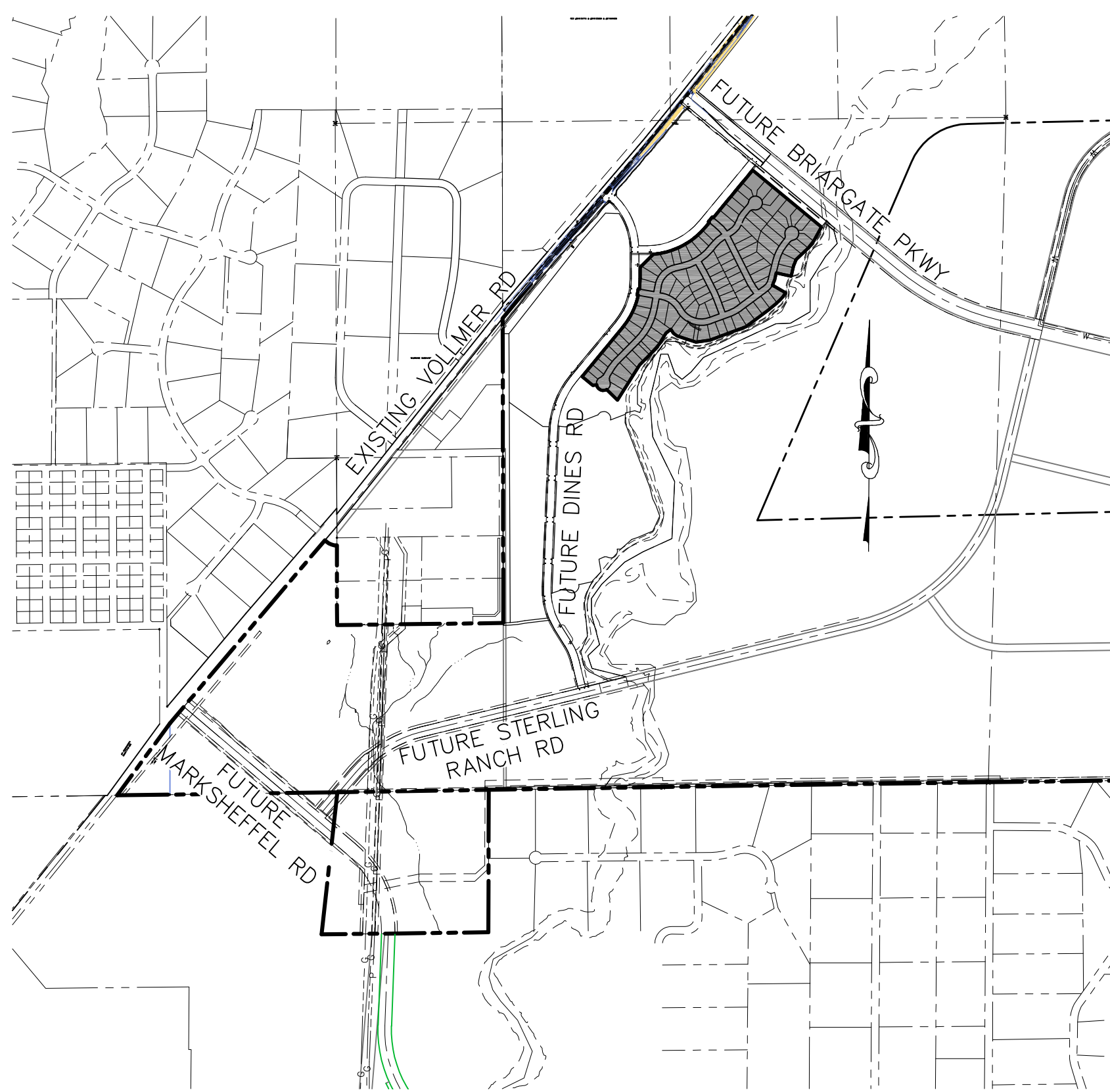

SITE MAP  
 N.T.S.

**ADDITIONAL NOTES:**

- STAGING AREA TO BE DETERMINED BY CONTRACTOR IN THE FIELD. THE LOCATIONS SHALL BE DELINEATED ON THIS PLAN BY THE CONTRACTOR.
- THE EROSION CONTROL DELINEATED ON THIS PLAN SHALL BE REGULARLY UPDATED BY THE CONTRACTOR.
- TEMPORARY SEDIMENT TRAP LOCATIONS WILL BE DETERMINED BY THE CONTRACTOR IN THE FIELD.
- EXISTING SITE TERRAIN GENERALLY SLOPES FROM NORTH TO SOUTHWEST AT GRADE RATES THAT VARY BETWEEN 2% TO 6%.
- THERE ARE NO BATCH PLANTS ON SITE.
- AREAS LEFT OPEN FOR 30 DAYS OR MORE, OTHER THAN FOR UTILITY AND DRAINAGE CONSTRUCTION SHALL BE SEEDED AND/OR MULCHED.
- NO PORTION OF THE PLATTED SINGLE FAMILY LOTS ARE LOCATED WITHIN A DESIGNATED FEMA FLOODPLAIN IN ACCORDANCE WITH FLOOD INSURANCE RATE MAPS (FIRM) 08041C0535G, EFFECTIVE DATE JULY 23, 2009.

**BENCHMARKS**

- THE TOP OF AN ALUMINUM SURVEYORS CAP, STAMPED "9853", AT THE SOUTHEAST BOUNDARY CORNER OF BARBARICK SUBDIVISION  
 NORTHING = 411416.273  
 EASTING = 235167.071  
 ELEVATION = 7023.42
- THE TOP OF A RED PLASTIC SURVEYORS CAP, ILLEGIBLE, AT THE NORTHWEST BOUNDARY CORNER OF PAWNEE RANCHEROS SUBDIVISION  
 NORTHING = 410095.404  
 EASTING = 235052.131  
 ELEVATION = 7000.40
- THE TOP OF A RED PLASTIC SURVEYORS CAP, STAMPED "38141", AT THE SOUTHWEST BOUNDARY CORNER OF BARBARICK SUBDIVISION  
 NORTHING = 411399.962  
 EASTING = 233849.817  
 ELEVATION = 7030.82

**AGENCIES**

- OWNER/DEVELOPER: SR LAND, LLC  
 20 BOULDER CRESCENT, SUITE 201  
 COLORADO SPRINGS, CO 80901  
 JIM MORLEY (719) 471-1742
- CIVIL ENGINEER: M & S CIVIL CONSULTANTS, INC.  
 102 E. PIKES PEAK, 5TH FLOOR  
 COLORADO SPRINGS, CO 80903  
 VIRGIL A. SANCHEZ P.E. (719) 955-5485
- COUNTY ENGINEERING: EL PASO COUNTY PLANNING AND COMMUNITY DEVELOPMENT  
 2880 INTERNATIONAL CIRCLE, SUITE 110  
 COLORADO SPRINGS, CO 80910  
 JEFF RICE, P.E. (719) 520-6300
- TRAFFIC ENGINEERING: EL PASO COUNTY DEPARTMENT OF PUBLIC WORKS  
 3275 AKERS DRIVE  
 COLORADO SPRINGS, CO 80922  
 JENNIFER IRVINE, P.E. (719) 520-6460
- WATER RESOURCES: STERLING RANCH METRO DISTRICT ENGINEERS  
 JDS-HYDRO CONSULTANTS  
 545 E. PIKES PEAK AVE., SUITE 300  
 COLORADO SPRINGS, CO 80903  
 JOHN MCGINN (719) 668-8769
- FIRE DISTRICT: BLACK FOREST FIRE PROTECTION DISTRICT  
 11445 TEACOUT ROAD  
 COLORADO SPRINGS, CO 80908  
 CHIEF BRYAN JACK (719) 495-4300
- GAS DEPARTMENT: COLORADO SPRINGS UTILITIES  
 7710 DURANT DR.  
 COLORADO SPRINGS, CO 80947  
 TIM WENDT (719) 668-3556
- ELECTRIC DEPARTMENT: MOUNTAIN VIEW ELECTRIC  
 11140 E. WOODMEN ROAD  
 FALCON, CO 80831  
 (719) 495-2283
- COMMUNICATIONS: QWEST COMMUNICATIONS  
 (U.N.C.C. LOCATORS) (800) 922-1987  
 AT&T (LOCATORS) (719) 635-3674

**ENGINEER'S STATEMENT:**

THIS GRADING AND EROSION CONTROL PLAN WAS PREPARED UNDER MY DIRECTION AND SUPERVISION AND IS CORRECT TO THE BEST OF MY KNOWLEDGE AND BELIEF. SAID PLAN HAS BEEN PREPARED ACCORDING TO THE CRITERIA ESTABLISHED BY THE COUNTY FOR GRADING AND EROSION CONTROL PLANS. I ACCEPT RESPONSIBILITY FOR ANY LIABILITY CAUSED BY NEGLIGENT ACTS, ERRORS OR OMISSIONS ON MY PART IN PREPARING THIS PLAN.



VIRGIL A. SANCHEZ, COLORADO P.E. NO. 37160  
 FOR AND ON BEHALF OF M&S CIVIL CONSULTANTS, INC. DATE

**OWNER'S STATEMENT:**

I, THE OWNER/DEVELOPER HAVE READ AND WILL COMPLY WITH THE REQUIREMENTS OF THE GRADING AND EROSION CONTROL PLAN.

JAMES F. MORLEY DATE  
 SR LAND, LLC  
 20 BOULDER, SUITE 201  
 COLORADO SPRINGS, CO 80903

**EL PASO COUNTY:**

COUNTY PLAN REVIEW IS PROVIDED ONLY FOR GENERAL CONFORMANCE WITH COUNTY DESIGN CRITERIA. THE COUNTY IS NOT RESPONSIBLE FOR THE ACCURACY AND ADEQUACY OF THE DESIGN, DIMENSIONS, AND/OR ELEVATIONS WHICH SHALL BE CONFIRMED AT THE JOB SITE. THE COUNTY THROUGH THE APPROVAL OF THIS DOCUMENT ASSUMES NO RESPONSIBILITY FOR COMPLETENESS AND/OR ACCURACY OF THIS DOCUMENT.

FILED IN ACCORDANCE WITH THE REQUIREMENTS OF THE EL PASO COUNTY LAND DEVELOPMENT CODE, DRAINAGE CRITERIA MANUAL VOLUMES 1 AND 2, AND ENGINEERING CRITERIA MANUAL AS AMENDED.

IN ACCORDANCE WITH ECM SECTION 1.12, THESE CONSTRUCTION DOCUMENTS WILL BE VALID FOR CONSTRUCTION FOR A PERIOD OF 2 YEARS FROM THE DATE SIGNED BY THE EL PASO COUNTY ENGINEER. IF CONSTRUCTION HAS NOT STARTED WITHIN THESE 2 YEARS, THE PLANS WILL NEED TO BE RESUBMITTED FOR APPROVAL, INCLUDING PAYMENT OF REVIEW FEES AT THE PLANNING AND COMMUNITY DEVELOPMENT DIRECTOR'S DISCRETION.

JENNIFER IRVINE, P.E. DATE  
 COUNTY ENGINEER/ECM ADMINISTRATOR

**SHEET INDEX**

SHEET 1	TITLE SHEET
SHEET 2	GRADING & EROSION CONTROL PLAN
SHEET 3	GRADING & EROSION CONTROL DETAILS
SHEET 4	GRADING & EROSION CONTROL DETAILS
SHEET 5	GRADING & EROSION CONTROL DETAILS
SHEET 6	GRADING & EROSION CONTROL DETAILS
SHEET 7	GRADING & EROSION CONTROL DETAILS
SHEET 8	GRADING & EROSION CONTROL DETAILS

**STATEMENT:**  
 THE CITY OF COLORADO SPRINGS RECOGNIZES THE DESIGN ENGINEER AS HAVING RESPONSIBILITY FOR THE DESIGN; THE CITY HAS LIMITED ITS SCOPE OF REVIEW ACCORDINGLY. RESUBMITTAL REQUIRED IF CONSTRUCTION HAS NOT COMMENCED WITHIN 180 DAYS AFTER APPROVAL DATE.



**HOMESTEAD AT STERLING RANCH FILING NO. 2**  
**FINAL GRADING / EROSION CONTROL PLAN**  
 PROJECT NO. 09-007 FILE: \Lang\Const\Eng\Grading & Erosion Control Plans\FGR01.dwg  
 DATE: 03-23-2020  
 SCALE: N/A  
 HORIZ: N/A  
 DLM: JWP  
 VAS: VAS  
 SHEET 1 OF 8  
**FGR01**

102 E. PIKES PEAK AVE., 5TH FLOOR  
 COLORADO SPRINGS, CO 80903  
 PHONE: 719.955.5485

**CIVIL CONSULTANTS, INC.**

FOR AND ON BEHALF OF  
 M&S CIVIL CONSULTANTS, INC.

VIRGIL A. SANCHEZ, COLORADO P.E. NO. 37160

NO.	DATE	BY:	DESCRIPTION:

THE ENGINEER PREPARING THESE PLANS WILL NOT BE RESPONSIBLE FOR UNAUTHORIZED CHANGES TO OR USES OF THESE PLANS. ALL CHANGES TO THE PLANS MUST BE IN WRITING AND MUST BE APPROVED BY THE PREPARER OF THESE PLANS.

**CAUTION**



**LEGEND**

- (6920) --- EXISTING MAJOR CONTOUR
- (6918) --- EXISTING MINOR CONTOUR
- 6920 --- PROPOSED MAJOR CONTOUR
- 6918 --- PROPOSED MINOR CONTOUR
- FILING BOUNDARY LINE
- RIGHT-OF-WAY LINE
- PROPOSED PROPERTY LINE
- FUTURE PROPERTY LINE
- EXISTING PROPERTY LINE
- LIMITS OF DISTURBANCE/ CONSTRUCTION BOUNDARY
- CURB & GUTTER FLOW LINE
- PROPOSED STORM DRAIN
- EXISTING STORM DRAIN
- SWALE
- 100YR --- 100-YR FLOOD PLAIN
- A --- TYPE A LOT
- B --- TYPE B LOT
- G --- TYPE G LOT
- W/O --- TYPE W/O LOT
- T --- TRANSITION LOT
- [Pattern] --- EX. WETLANDS
- [Pattern] --- WETLAND DISTURBANCE
- [Symbol] --- INLET
- [Symbol] --- L.P./H.P.
- [Symbol] --- FLOW DIRECTION & SLOPE (2.0%)
- [Symbol] --- FLOW DIRECTION ARROW
- [Symbol] --- EXISTING FLOW DIRECTION ARROW
- [Symbol] --- EMERGENCY OVERFLOW DIRECTION
- [Symbol] --- RIPRAP TYP. - PERM
- [Symbol] --- CWA --- CONCRETE WASHOUT AREA - INTERIM
- [Symbol] --- IP --- INLET PROTECTION - INTERIM
- [Symbol] --- SBB --- STRAW BALE DITCH CHECK - INTERIM
- [Symbol] --- SF --- SILT FENCE - INTERIM
- [Symbol] --- VTC --- VEHICLE TRACKING CONTROL - INTERIM
- [Symbol] --- TRM --- NORTH AMERICAN GREEN SC250 PERMANENT EROSION CONTROL BLANKET (OR APPROVED EQUAL) - PERM
- [Symbol] --- TRM --- NORTH AMERICAN GREEN SC150 TEMPORARY EROSION CONTROL BLANKET (OR APPROVED EQUAL) - PERM

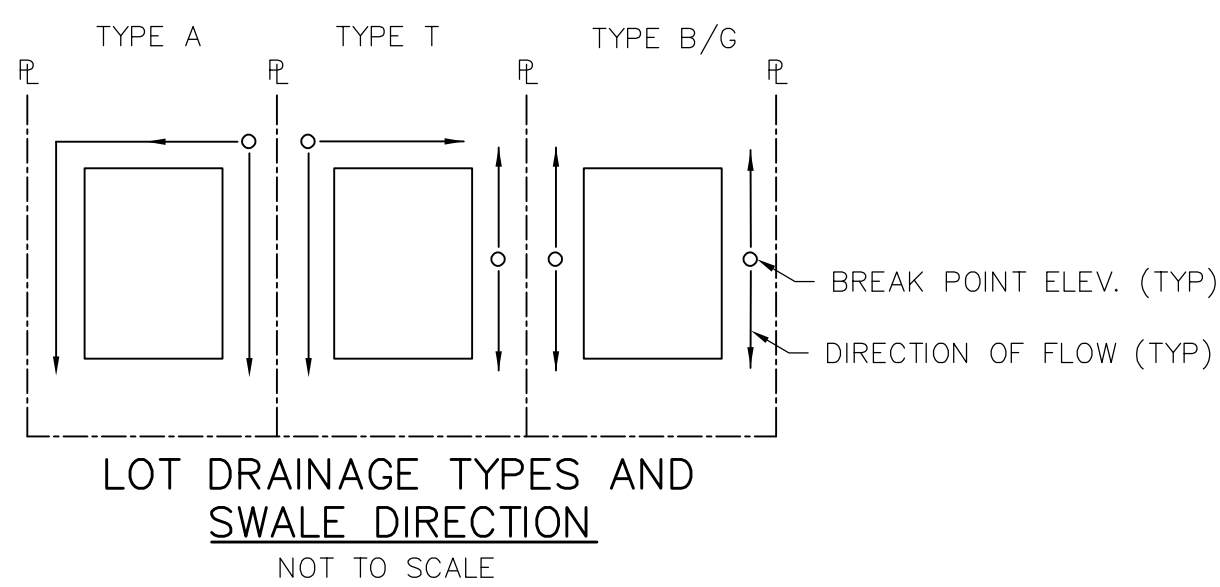

**ADDITIONAL NOTES:**  
STAGING, STORAGE AND STOCKPILE AREAS TO BE DETERMINED BY CONTRACTOR IN THE FIELD. THE LOCATIONS SHALL BE DELINEATED ON THIS PLAN BY THE CONTRACTOR.

THE EROSION CONTROL DELINEATED ON THIS PLAN SHALL BE REGULARLY UPDATED BY THE CONTRACTOR.

ALL TEMPORARY OR PERMANENT GRADING DISTURBANCES SHALL BE RE-SEEDED AND MULCHED PER EL PASO COUNTY CRITERIA AND SPECIFICATIONS.

**CONSTRUCTION NOTES:**

NO WETLANDS ARE TO BE PERMANENTLY DISTURBED PER THIS GRADING PLAN.

NO GRADING IS TO OCCUR WITHIN THE 100 YEAR FLOODPLAIN.

ALL TEMPORARY RIPRAP SHOWN ON THE PLANS SHALL BE TYPE 'M'. RIPRAP SHALL BE PLACED IN THE LOCATIONS INDICATED BY THE PLAN OR IN AREAS AS THE CONTRACTOR SEES FIT TO CONTROL EROSION. ALL RIPRAP SHALL BE PLACED AT A MINIMUM THICKNESS OF 1.5' DEEP.

ALL TEMPORARY STORM SEWER SHOWN ON PLANS SHALL BE 24" DIA. HD POLYPROPYLENE BY ADS OR APPROVED EQUAL. ALL PIPE SHALL BE LAID TO ACHIEVE A MIN. SLOPE OF 0.5%.

AREAS OUTSIDE OF THE CONSTRUCTION SITE BOUNDARY PROTECTED BY SILT FENCE AND/OR LIMITS OF DISTURBANCE.

FOR CONSTRUCTION DRAWINGS AND DETAILS; SEE SAND CREEK BANK STABILIZATION PLAN, & STORM SEWERS PLANS FOR HOMESTEAD AT STERLING RANCH FILING NO. 2. BY M&S CIVIL CONSULTANTS, INC.

SAND CREEK CHANNEL IMPROVEMENTS PLANS ARE FORTHCOMING PROVIDED BY KIOWA ENGINEERING. THESE PLANS WILL DEPICT THE IMPROVEMENTS TO SAND CREEK CHANNEL, THE FINAL TRAIL LOCATION AND MAINTENANCE ACCESS LOCATIONS FOR THE SAND CREEK DRAINAGE STRUCTURES.

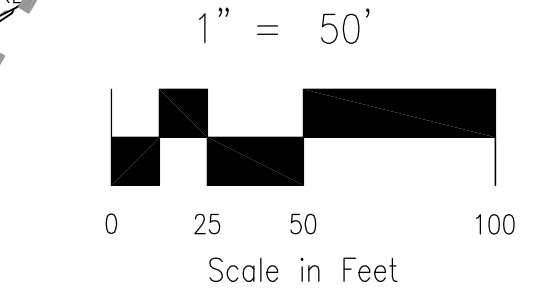
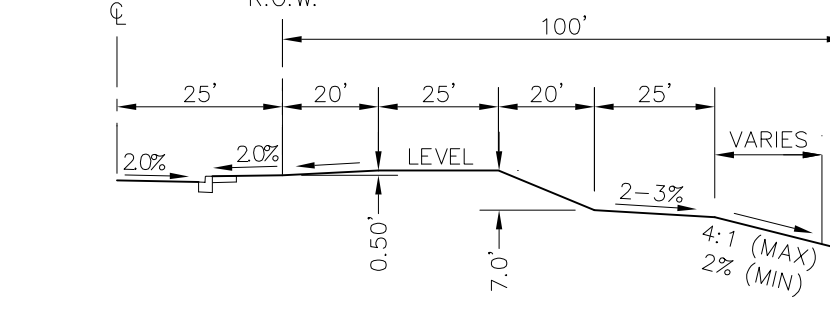
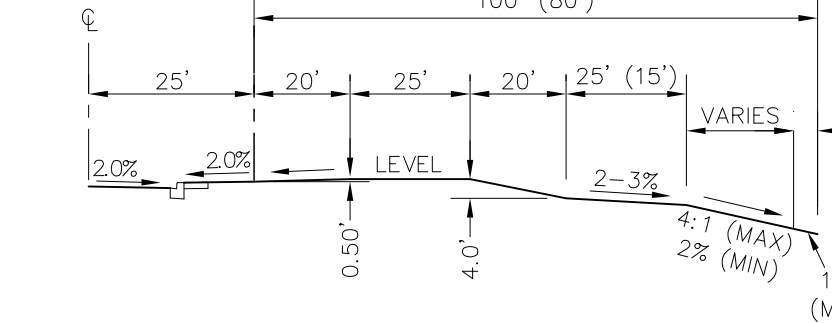
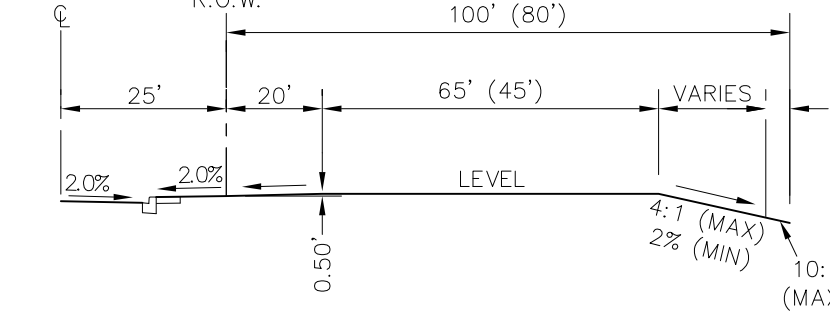
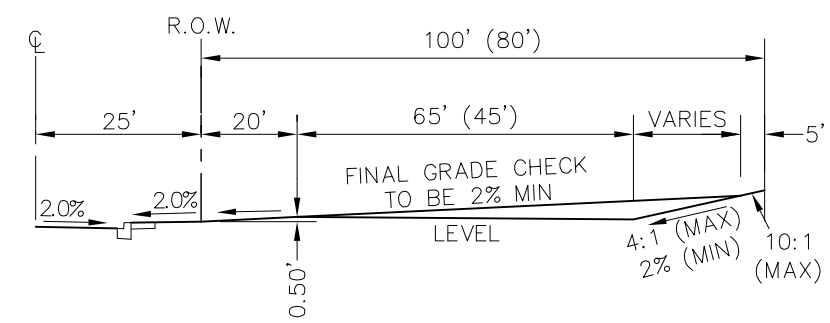
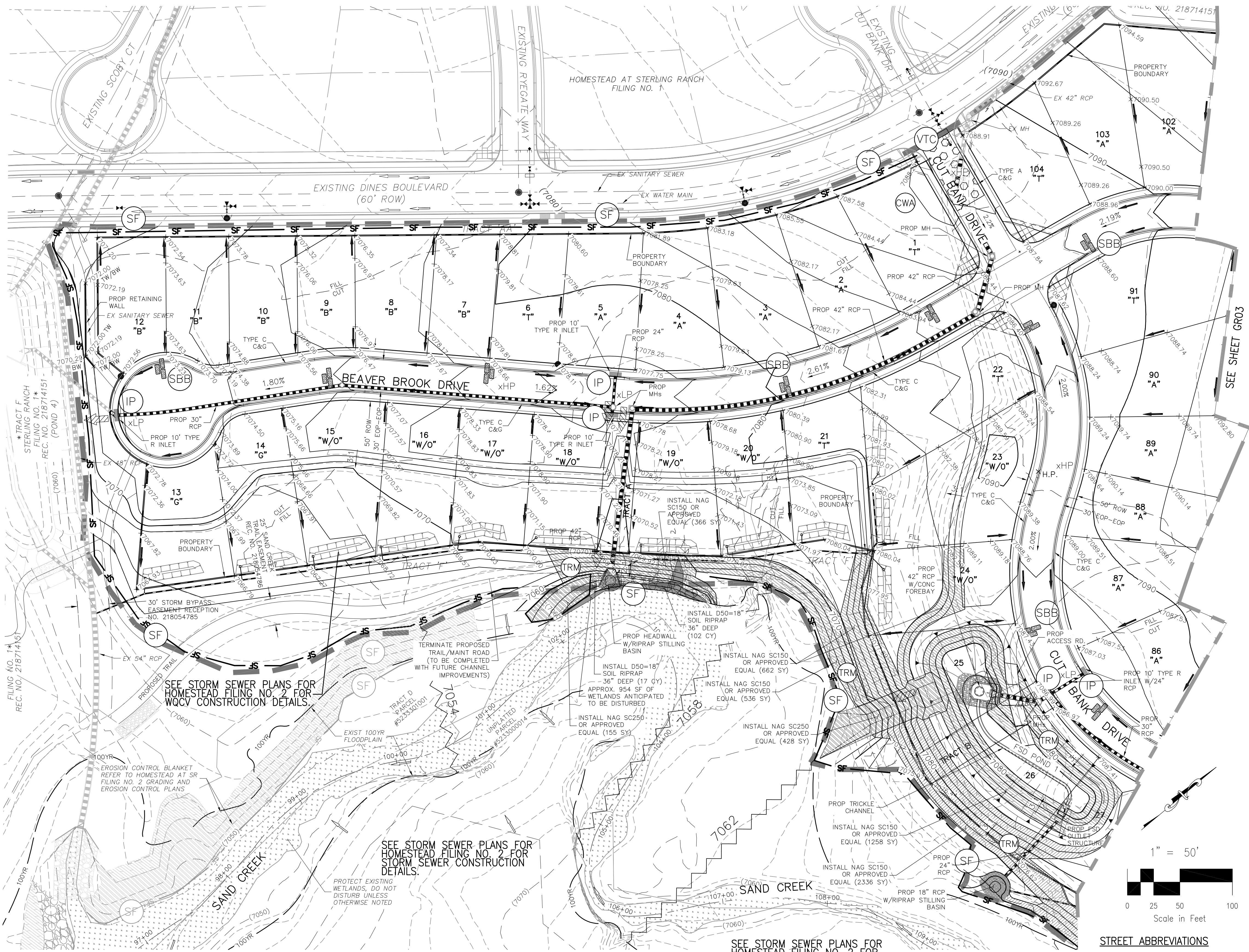

- STREET ABBREVIATIONS**
- CBD CUT BANK DRIVE
  - BBD BEAVER BROOK DRIVE
  - GDW GLENVIEW WAY
  - ND NIARADA DRIVE

FOR LOCATING & MARKING GAS, ELECTRIC, WATER & TELEPHONE LINES  
**FOR BURIED UTILITY INFORMATION 48 HRS BEFORE YOU DIG CALL 1-800-922-1987**

**HOMESTEAD AT STERLING RANCH FILING NO. 2**  
**FINAL GRADING / EROSION CONTROL PLAN**  
PROJECT NO. 09-007 DATE: 03-03-2020  
SCALE: HORIZONTAL: 1"=50' VERTICAL: N/A  
DESIGNED BY: DLM DRAWN BY: JVP CHECKED BY: N/A  
SHEET 2 OF 8 **FGR02**

102 E. PINE PEAK AVE., 5TH FLOOR  
COLORADO SPRINGS, CO 80903  
PHONE: 719.555.4485

**CIVIL CONSULTANTS, INC.**

FOR AND ON BEHALF OF M&S CIVIL CONSULTANTS, INC.

MIRCEL A. SANCHEZ, COLORADO P.E. NO. 371160

REVISIONS: NO. DATE: BY: DESCRIPTION:

THE ENGINEER PREPARING THESE PLANS WILL NOT BE RESPONSIBLE FOR UNAUTHORIZED CHANGES TO OR USES OF THESE PLANS. ALL CHANGES TO THE PLANS MUST BE IN WRITING AND MUST BE APPROVED BY THE PREPARER OF THESE PLANS.

**CAUTION**



**LEGEND**

- (6920) --- EXISTING MAJOR CONTOUR
- (6918) --- EXISTING MINOR CONTOUR
- 6920 --- PROPOSED MAJOR CONTOUR
- 6918 --- PROPOSED MINOR CONTOUR
- FILING BOUNDARY LINE
- RIGHT-OF-WAY LINE
- PROPOSED PROPERTY LINE
- FUTURE PROPERTY LINE
- EXISTING PROPERTY LINE
- LIMITS OF DISTURBANCE/CONSTRUCTION BOUNDARY
- CURB & GUTTER FLOW LINE
- PROPOSED STORM DRAIN
- EXISTING STORM DRAIN
- SWALE
- 100YR --- 100-YR FLOOD PLAIN
- A --- TYPE A LOT
- B --- TYPE B LOT
- G --- TYPE G LOT
- W/O --- TYPE W LOT
- T --- TRANSITION LOT
- EX. WETLANDS
- WETLAND DISTURBANCE
- INLET
- L.P./H.P. (2.0%)
- FLOW DIRECTION & SLOPE
- FLOW DIRECTION ARROW
- EXISTING FLOW DIRECTION ARROW
- EMERGENCY OVERFLOW DIRECTION
- RIPRAP TYP. - PERM
- CONCRETE WASHOUT AREA - INTERIM
- INLET PROTECTION - INTERIM
- STRAW BALE DITCH CHECK - INTERIM
- SF --- TEMPORARY SEDIMENT BASIN
- VTC --- VEHICLE TRACKING CONTROL - INTERIM
- TRM --- NORTH AMERICAN GREEN SC250 PERMANENT EROSION CONTROL BLANKET (OR APPROVED EQUAL) - PERM
- TRM --- NORTH AMERICAN GREEN SC150 TEMPORARY EROSION CONTROL BLANKET (OR APPROVED EQUAL) - PERM
- TYPE A --- TYPE B/G ---
- BREAK POINT ELEV. (TYP)
- DIRECTION OF FLOW (TYP)

**LOT DRAINAGE TYPES AND SWALE DIRECTION**  
NOT TO SCALE

**ADDITIONAL NOTES:**  
STAGING, STORAGE AND STOCKPILE AREAS TO BE DETERMINED BY CONTRACTOR IN THE FIELD. THE LOCATIONS SHALL BE DELINEATED ON THIS PLAN BY THE CONTRACTOR.

THE EROSION CONTROL DELINEATED ON THIS PLAN SHALL BE REGULARLY UPDATED BY THE CONTRACTOR.

ALL TEMPORARY OR PERMANENT GRADING DISTURBANCES SHALL BE RE-SEEDING AND MULCHED PER EL PASO COUNTY CRITERIA AND SPECIFICATIONS.

**CONSTRUCTION NOTES:**

NO WETLANDS ARE TO BE PERMANENTLY DISTURBED PER THIS GRADING PLAN.

NO GRADING IS TO OCCUR WITHIN THE 100 YEAR FLOODPLAIN.

ALL TEMPORARY RIPRAP SHOWN ON THE PLANS SHALL BE TYPE 'W'. RIPRAP SHALL BE PLACED IN THE LOCATIONS INDICATED BY THE PLAN OR IN AREAS AS THE CONTRACTOR SEES FIT TO CONTROL EROSION. ALL RIPRAP SHALL BE PLACED AT A MINIMUM THICKNESS OF 1.5' DEEP.

ALL TEMPORARY STORM SEWER SHOWN ON PLANS SHALL BE 24" DIA HP POLYPROPYLENE BY ADS OR APPROVED EQUAL. ALL PIPE SHALL BE LAID TO ACHIEVE A MIN. SLOPE OF 0.5%.

AREAS OUTSIDE OF THE CONSTRUCTION SITE BOUNDARY PROTECTED BY SILT FENCE AND/OR LIMITS OF DISTURBANCE.

FOR CONSTRUCTION DRAWINGS AND DETAILS; SEE SAND CREEK BANK STABILIZATION PLAN, & STORM SEWERS PLANS FOR HOMESTEAD AT STERLING RANCH FILING NO. 2. BY M&S CIVIL CONSULTANTS, INC.

SAND CREEK CHANNEL IMPROVEMENTS PLANS ARE FORTHCOMING PROVIDED BY KIOWA ENGINEERING. THESE PLANS WILL DEPICT THE IMPROVEMENTS TO SAND CREEK CHANNEL, THE FINAL TRAIL LOCATION AND MAINTENANCE ACCESS LOCATIONS FOR THE SAND CREEK DRAINAGE STRUCTURES.

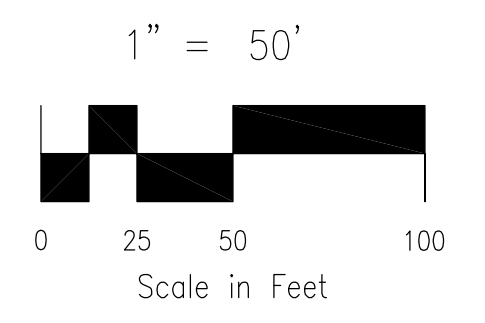
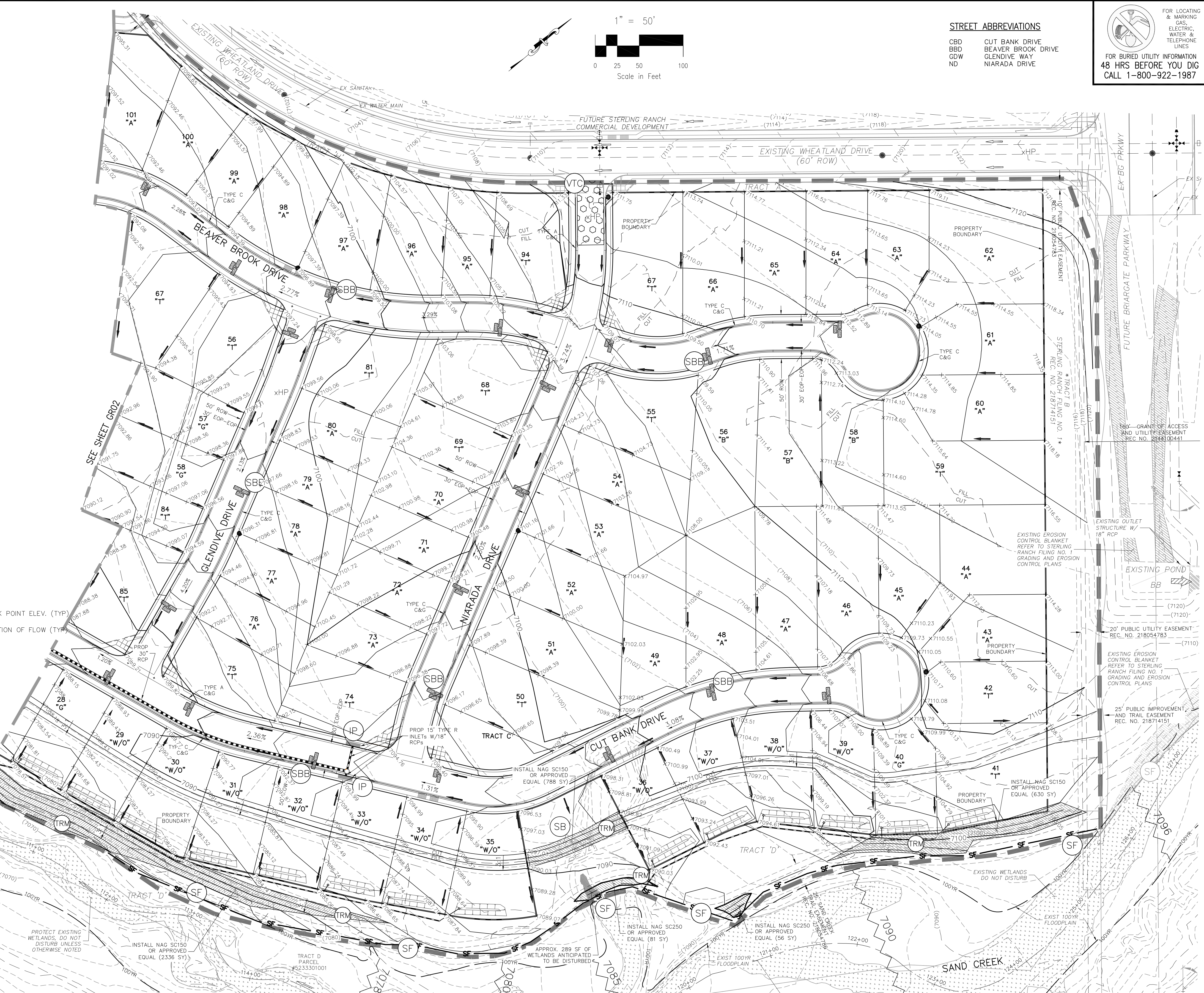

**STREET ABBREVIATIONS**

CBD	CUT BANK DRIVE
BBD	BEAVER BROOK DRIVE
GDW	GLENDIVE WAY
ND	NIARADA DRIVE

FOR LOCATING & MARKING GAS, ELECTRIC, WATER & TELEPHONE LINES  
FOR BURIED UTILITY INFORMATION  
48 HRS BEFORE YOU DIG  
CALL 1-800-922-1987

**HOMESTEAD AT STERLING RANCH FILING NO. 2**

**GRADING PLAN**

PROJECT NO. 09-007 DATE: 03-03-2020

SCALE: HORIZONTAL: 1"=50' VERTICAL: N/A

DESIGNED BY: DLM DRAWN BY: JWP CHECKED BY: VAS

FOR AND ON BEHALF OF M&S CIVIL CONSULTANTS, INC.

MIRCEL A. SANCHEZ, COLORADO P.E. NO. 37160

102 E. PINE PEAK AVE., 5TH FLOOR  
COLORADO SPRINGS, CO 80903  
PHONE: 719.555.5485

CIVIL CONSULTANTS, INC.

FOR AND ON BEHALF OF M&S CIVIL CONSULTANTS, INC.

MIRCEL A. SANCHEZ, COLORADO P.E. NO. 37160

NO. DATE: REVISIONS: BY: DESCRIPTION:

THE ENGINEER PREPARING THESE PLANS WILL NOT BE RESPONSIBLE OR LIABLE FOR UNAUTHORIZED CHANGES TO OR USES OF THESE PLANS. ALL CHANGES TO THE PLANS MUST BE IN WRITING AND MUST BE APPROVED BY THE PREPARER OF THESE PLANS.

CAUTION

File: 0\_100071A\Sterling Ranch No 6\Eng\Const\Draw\Grading Plans\FGR02-03.dwg PlotStamp: 3/27/2020 11:56 AM







SC-6 Inlet Protection (IP)

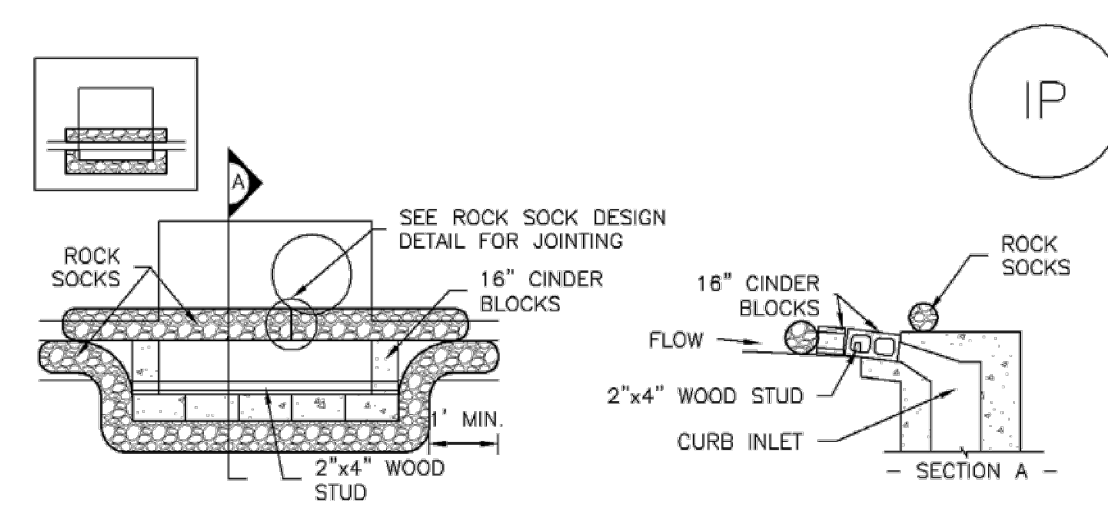

IP-1. BLOCK AND ROCK SOCK SUMP OR ON GRADE INLET PROTECTION

**BLOCK AND CURB SOCK INLET PROTECTION INSTALLATION NOTES**

- SEE ROCK SOCK DESIGN DETAIL FOR INSTALLATION REQUIREMENTS.
- CONCRETE "CINDER" BLOCKS SHALL BE LAD ON THEIR SIDES AROUND THE INLET IN A SINGLE ROW, ABUTTING ONE ANOTHER WITH THE OPEN END FACING AWAY FROM THE CURB.
- GRAVEL BAGS SHALL BE PLACED AROUND CONCRETE BLOCKS, CLOSELY ABUTTING ONE ANOTHER AND JOINED TOGETHER IN ACCORDANCE WITH ROCK SOCK DESIGN DETAIL.

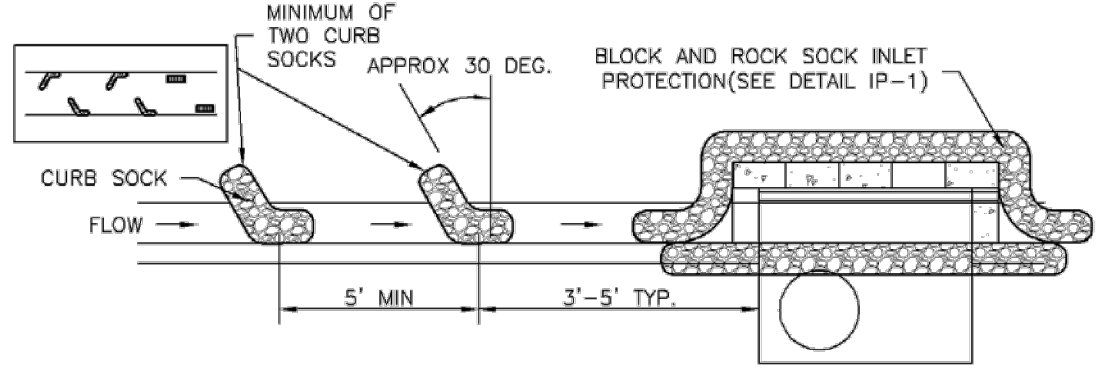

IP-2. CURB ROCK SOCKS UPSTREAM OF INLET PROTECTION

**CURB ROCK SOCK INLET PROTECTION INSTALLATION NOTES**

- SEE ROCK SOCK DESIGN DETAIL INSTALLATION REQUIREMENTS.
- PLACEMENT OF THE SOCK SHALL BE APPROXIMATELY 30 DEGREES FROM PERPENDICULAR IN THE OPPOSITE DIRECTION OF FLOW.
- SOCKS ARE TO BE FLUSH WITH THE CURB AND SPACED A MINIMUM OF 5 FEET APART.
- AT LEAST TWO CURB SOCKS IN SERIES ARE REQUIRED UPSTREAM OF ON-GRADE INLETS.

IP-4 Urban Drainage and Flood Control District August 2013  
Urban Storm Drainage Criteria Manual Volume 3

SC-6 Inlet Protection (IP)

**GENERAL INLET PROTECTION INSTALLATION NOTES**

- SEE PLAN VIEW FOR:
  - LOCATION OF INLET PROTECTION.
  - TYPE OF INLET PROTECTION (IP-1, IP-2, IP-3, IP-4, IP-5, IP-6)
- INLET PROTECTION SHALL BE INSTALLED PROMPTLY AFTER INLET CONSTRUCTION OR PAVING IS COMPLETE (TYPICALLY WITHIN 48 HOURS). IF A RAINFALL/RUNOFF EVENT IS FORECAST, INSTALL INLET PROTECTION PRIOR TO ONSET OF EVENT.
- MANY JURISDICTIONS HAVE BMP DETAILS THAT VARY FROM UDFCD STANDARD DETAILS. CONSULT WITH LOCAL JURISDICTIONS AS TO WHICH DETAIL SHOULD BE USED WHEN DIFFERENCES ARE NOTED.

**INLET PROTECTION MAINTENANCE NOTES**

- INSPECT BMPs EACH WORKDAY, AND MAINTAIN THEM IN EFFECTIVE OPERATING CONDITION. MAINTENANCE OF BMPs SHOULD BE PROACTIVE, NOT REACTIVE. INSPECT BMPs AS SOON AS POSSIBLE (AND ALWAYS WITHIN 24 HOURS) FOLLOWING A STORM THAT CAUSES SURFACE EROSION, AND PERFORM NECESSARY MAINTENANCE.
- FREQUENT OBSERVATIONS AND MAINTENANCE ARE NECESSARY TO MAINTAIN BMPs IN EFFECTIVE OPERATING CONDITION. INSPECTIONS AND CORRECTIVE MEASURES SHOULD BE DOCUMENTED THOROUGHLY.
- WHERE BMPs HAVE FAILED, REPAIR OR REPLACEMENT SHOULD BE INITIATED UPON DISCOVERY OF THE FAILURE.
- SEDIMENT ACCUMULATED UPSTREAM OF INLET PROTECTION SHALL BE REMOVED AS NECESSARY TO MAINTAIN BMP EFFECTIVENESS, TYPICALLY WHEN STORAGE VOLUME REACHES SOLE OF CAPACITY, A DEPTH OF 6" WHEN SILT FENCE IS USED, OR 1/4 OF THE HEIGHT FOR STRAW BALES.
- INLET PROTECTION IS TO REMAIN IN PLACE UNTIL THE UPSTREAM DISTURBED AREA IS PERMANENTLY STABILIZED, UNLESS THE LOCAL JURISDICTION APPROVES EARLIER REMOVAL OF INLET PROTECTION IN STREETS.
- WHEN INLET PROTECTION AT AREA INLETS IS REMOVED, THE DISTURBED AREA SHALL BE COVERED WITH TOP SOIL, SEEDED AND MULCHED, OR OTHERWISE STABILIZED IN A MANNER APPROVED BY THE LOCAL JURISDICTION.

(DETAIL ADAPTED FROM TOWN OF PARKER, COLORADO AND CITY OF AURORA, COLORADO, NOT AVAILABLE IN AUTOCAD)

NOTE: MANY JURISDICTIONS HAVE BMP DETAILS THAT VARY FROM UDFCD STANDARD DETAILS. CONSULT WITH LOCAL JURISDICTIONS AS TO WHICH DETAIL SHOULD BE USED WHEN DIFFERENCES ARE NOTED.

NOTE: THE DETAILS INCLUDED WITH THIS FACT SHEET SHOW COMMONLY USED, CONVENTIONAL METHODS OF INLET PROTECTION IN THE DENVER METROPOLITAN AREA. THERE ARE MANY PROPRIETARY INLET PROTECTION METHODS ON THE MARKET. UDFCD NEITHER ENDORSES NOR DISCOURAGES USE OF PROPRIETARY INLET PROTECTION; HOWEVER, IN THE EVENT PROPRIETARY METHODS ARE USED, THE APPROPRIATE DETAIL FROM THE MANUFACTURER MUST BE INCLUDED IN THE SWMP AND THE BMP MUST BE INSTALLED AND MAINTAINED AS SHOWN IN THE MANUFACTURER'S DETAILS.

NOTE: SOME MUNICIPALITIES DISCOURAGE OR PROHIBIT THE USE OF STRAW BALES FOR INLET PROTECTION. CHECK WITH LOCAL JURISDICTION TO DETERMINE IF STRAW BALE INLET PROTECTION IS ACCEPTABLE.

IP-8 Urban Drainage and Flood Control District August 2013  
Urban Storm Drainage Criteria Manual Volume 3

SC-6 Inlet Protection (IP)

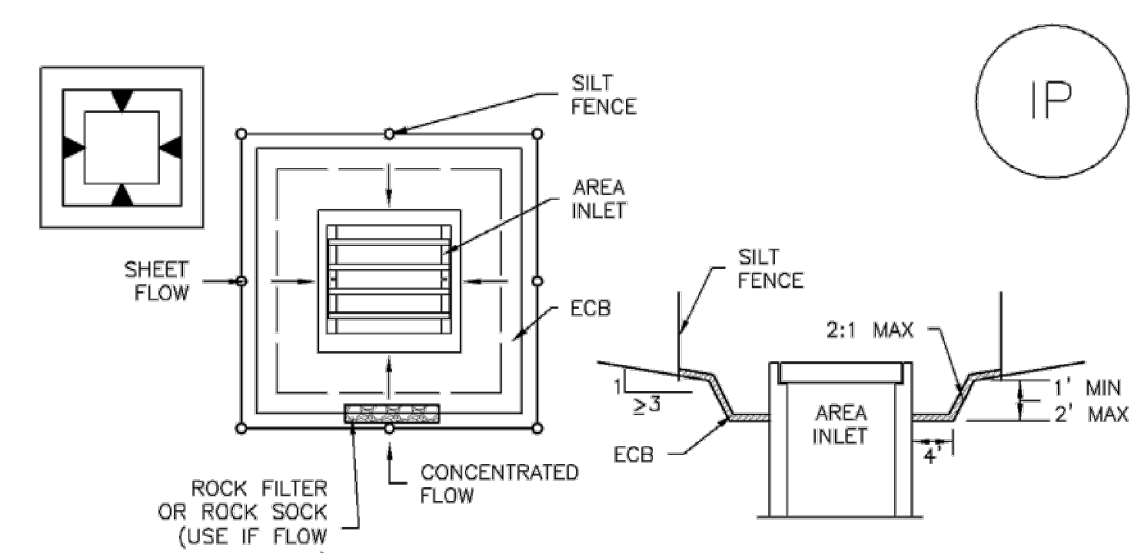

IP-5. OVEREXCAVATION INLET PROTECTION

**OVEREXCAVATION INLET PROTECTION INSTALLATION NOTES**

- THIS FORM OF INLET PROTECTION IS PRIMARILY APPLICABLE FOR SITES THAT HAVE NOT YET REACHED FINAL GRADE AND SHOULD BE USED ONLY FOR INLETS WITH A RELATIVELY SMALL CONTRIBUTING DRAINAGE AREA.
- WHEN USING FOR CONCENTRATED FLOWS, SHAPE BASIN IN 2:1 RATIO WITH LENGTH ORIENTED TOWARDS DIRECTION OF FLOW.
- SEDIMENT MUST BE PERIODICALLY REMOVED FROM THE OVEREXCAVATED AREA.

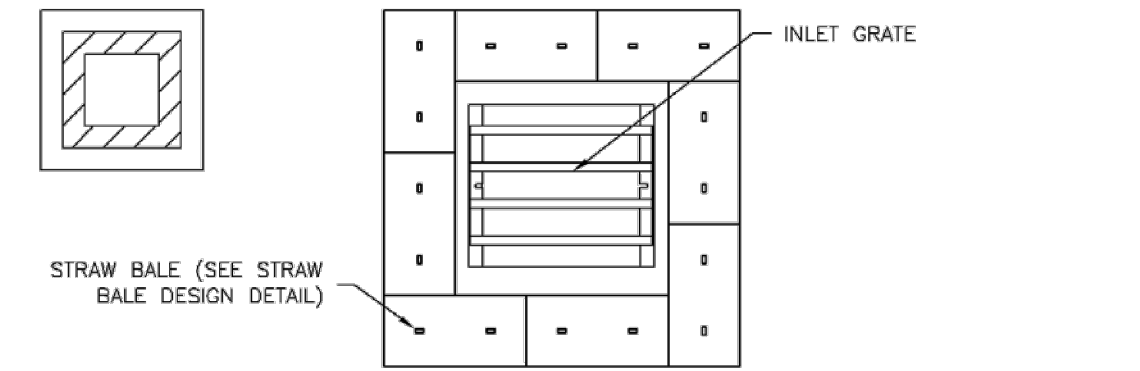

IP-6. STRAW BALE FOR SUMP INLET PROTECTION

**STRAW BALE BARRIER INLET PROTECTION INSTALLATION NOTES**

- SEE STRAW BALE DESIGN DETAIL FOR INSTALLATION REQUIREMENTS.
- BALES SHALL BE PLACED IN A SINGLE ROW AROUND THE INLET WITH ENDS OF BALES TIGHTLY ABUTTING ONE ANOTHER.

IP-6 Urban Drainage and Flood Control District August 2013  
Urban Storm Drainage Criteria Manual Volume 3

SC-6 Inlet Protection (IP)

- IP-3. Rock Sock Inlet Protection for Sump/Area Inlet
- IP-4. Silt Fence Inlet Protection for Sump/Area Inlet
- IP-5. Over-excavation Inlet Protection
- IP-6. Straw Bale Inlet Protection for Sump/Area Inlet
- CIP-1. Culvert Inlet Protection

Propriety inlet protection devices should be installed in accordance with manufacturer specifications. More information is provided below on selecting inlet protection for sump and on-grade locations.

**Inlets Located in a Sump**

When applying inlet protection in sump conditions, it is important that the inlet continue to function during larger runoff events. For curb inlets, the maximum height of the protective barrier should be lower than the top of the curb opening to allow overflow into the inlet during larger storms without excessive localized flooding. If the inlet protection height is greater than the curb elevation, particularly if the filter becomes clogged with sediment, runoff will not enter the inlet and may bypass it, possibly causing localized flooding, public safety issues, and downstream erosion and damage from bypassed flows.

Area inlets located in a sump setting can be protected through the use of silt fence, concrete block and rock socks (on paved surfaces), sediment control logs/straw wattles embedded in the adjacent soil and stacked around the area inlet (on pervious surfaces), over-excavation around the inlet, and proprietary products providing equivalent functions.

**Inlets Located on a Slope**

For curb and gutter inlets on paved sloping streets, block and rock sock inlet protection is recommended in conjunction with curb socks in the gutter leading to the inlet. For inlets located along unpaved roads, also see the Check Dam Fact Sheet.

**Maintenance and Removal**

Inspect inlet protection frequently. Inspection and maintenance guidance includes:

- Inspect for tears that can result in sediment directly entering the inlet, as well as result in the contents of the BMP (e.g., gravel) washing into the inlet.
- Check for improper installation resulting in untreated flows bypassing the BMP and directly entering the inlet or bypassing to an unprotected downstream inlet. For example, silt fence that has not been properly trenched around the inlet can result in flows under the silt fence and directly into the inlet.
- Look for displaced BMPs that are no longer protecting the inlet. Displacement may occur following larger storm events that wash away or reposition the inlet protection. Traffic or equipment may also crush or displace the BMP.
- Monitor sediment accumulation upgradient of the inlet protection.

IP-2 Urban Drainage and Flood Control District August 2013  
Urban Storm Drainage Criteria Manual Volume 3

Inlet Protection (IP) SC-6

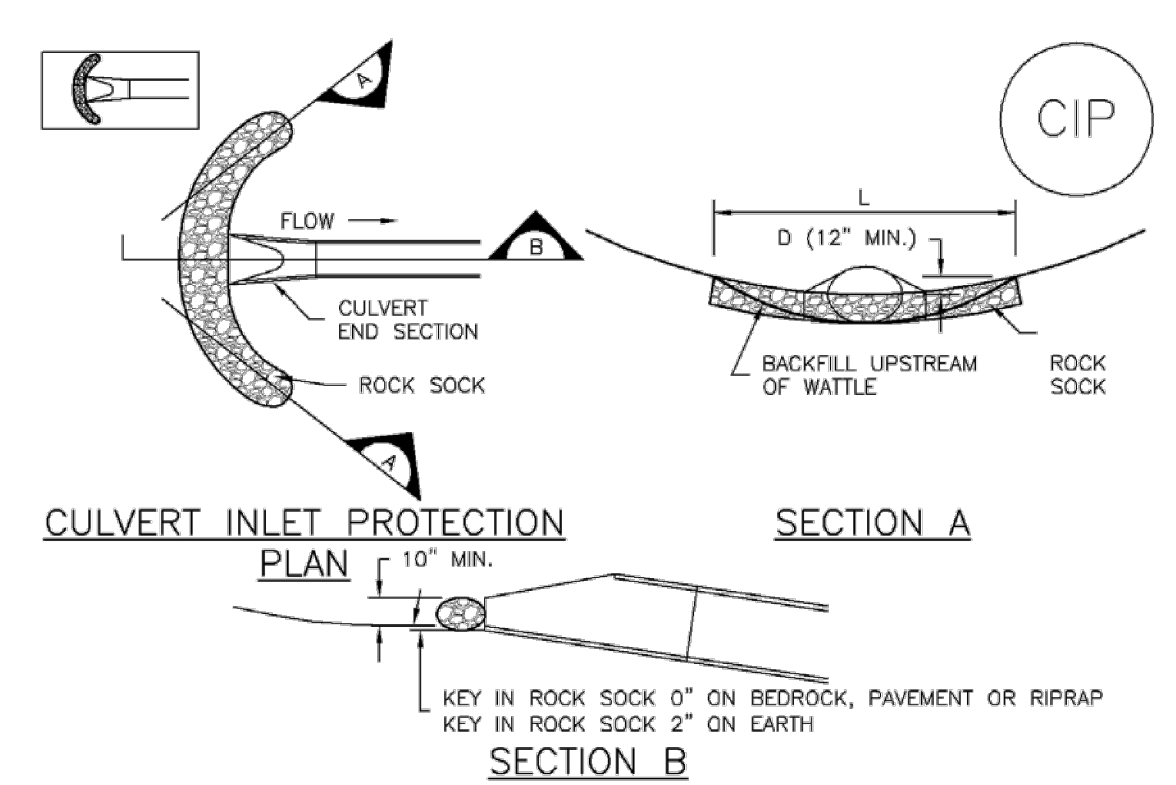

CIP-1. CULVERT INLET PROTECTION

**CULVERT INLET PROTECTION INSTALLATION NOTES**

- SEE PLAN VIEW FOR:
  - LOCATION OF CULVERT INLET PROTECTION.
- SEE ROCK SOCK DESIGN DETAIL FOR ROCK GRADATION REQUIREMENTS AND JOINING DETAIL.

**CULVERT INLET PROTECTION MAINTENANCE NOTES**

- INSPECT BMPs EACH WORKDAY, AND MAINTAIN THEM IN EFFECTIVE OPERATING CONDITION. MAINTENANCE OF BMPs SHOULD BE PROACTIVE, NOT REACTIVE. INSPECT BMPs AS SOON AS POSSIBLE (AND ALWAYS WITHIN 24 HOURS) FOLLOWING A STORM THAT CAUSES SURFACE EROSION, AND PERFORM NECESSARY MAINTENANCE.
- FREQUENT OBSERVATIONS AND MAINTENANCE ARE NECESSARY TO MAINTAIN BMPs IN EFFECTIVE OPERATING CONDITION. INSPECTIONS AND CORRECTIVE MEASURES SHOULD BE DOCUMENTED THOROUGHLY.
- WHERE BMPs HAVE FAILED, REPAIR OR REPLACEMENT SHOULD BE INITIATED UPON DISCOVERY OF THE FAILURE.
- SEDIMENT ACCUMULATED UPSTREAM OF THE CULVERT SHALL BE REMOVED WHEN THE SEDIMENT DEPTH IS 1/2 THE HEIGHT OF THE ROCK SOCK.
- CULVERT INLET PROTECTION SHALL REMAIN IN PLACE UNTIL THE UPSTREAM DISTURBED AREA IS PERMANENTLY STABILIZED AND APPROVED BY THE LOCAL JURISDICTION.

(DETAILS ADAPTED FROM AURORA, COLORADO, NOT AVAILABLE IN AUTOCAD)

NOTE: MANY JURISDICTIONS HAVE BMP DETAILS THAT VARY FROM UDFCD STANDARD DETAILS. CONSULT WITH LOCAL JURISDICTIONS AS TO WHICH DETAIL SHOULD BE USED WHEN DIFFERENCES ARE NOTED.

August 2013 Urban Drainage and Flood Control District August 2013  
Urban Storm Drainage Criteria Manual Volume 3 IP-7

Inlet Protection (IP) SC-6

- Remove sediment accumulation from the area upstream of the inlet protection, as needed to maintain BMP effectiveness, typically when it reaches no more than half the storage capacity of the inlet protection. For silt fence, remove sediment when it accumulates to a depth of no more than 6 inches. Remove sediment accumulation from the area upstream of the inlet protection as needed to maintain the functionality of the BMP.
  - Propriety inlet protection devices should be inspected and maintained in accordance with manufacturer specifications. If proprietary inlet insert devices are used, sediment should be removed in a timely manner to prevent devices from breaking and spilling sediment into the storm drain.
- Inlet protection must be removed and properly disposed of when the drainage area for the inlet has reached final stabilization.

August 2013 Urban Drainage and Flood Control District August 2013  
Urban Storm Drainage Criteria Manual Volume 3 IP-3

HOMESTEAD AT STERLING RANCH FILING NO. 2

**GRADING & EROSION CONTROL PLAN**

PROJECT NO. 09-007      DATE: 03-23-2020  
 DESIGNED BY: DLM      SCALE: N/A  
 DRAWN BY: JWP      HORIZONTAL: N/A  
 CHECKED BY: VAS      VERTICAL: N/A

SHEET 5 OF 8  
FGRO5

---

102 E. Pikes Peak Ave., 5th Floor  
 Colorado Springs, CO 80903  
 PHONE: 719.555.4485

**CIVIL CONSULTANTS, INC.**

---

FOR AND ON BEHALF OF  
 M&S CIVIL CONSULTANTS, INC.

Virgil A. Sanchez, Colorado P.E. No. 37760

---

NO.	DATE	BY	DESCRIPTION	APPROVED BY	DATE

THE ENGINEER PREPARING THESE PLANS WILL NOT BE RESPONSIBLE OR LIABLE FOR UNAUTHORIZED CHANGES TO OR USES OF THESE PLANS. ALL CHANGES TO THE PLANS MUST BE IN WRITING AND MUST BE APPROVED BY THE PREPARER OF THESE PLANS.

**CAUTION**







**SM-4 Vehicle Tracking Control (VTC)**

**STABILIZED CONSTRUCTION ENTRANCE/EXIT INSTALLATION NOTES**

- SEE PLAN VIEW FOR:
  - LOCATION OF CONSTRUCTION ENTRANCE(S)/EXIT(S).
  - TYPE OF CONSTRUCTION ENTRANCE(S)/EXIT(S) (WITH/WITHOUT WHEEL WASH, CONSTRUCTION MAT OR TRM).
- CONSTRUCTION MAT OR TRM STABILIZED CONSTRUCTION ENTRANCES ARE ONLY TO BE USED ON SHORT DURATION PROJECTS (TYPICALLY RANGING FROM A WEEK TO A MONTH) WHERE THERE WILL BE LIMITED VEHICULAR ACCESS.
- A STABILIZED CONSTRUCTION ENTRANCE/EXIT SHALL BE LOCATED AT ALL ACCESS POINTS WHERE VEHICLES ACCESS THE CONSTRUCTION SITE FROM PAVED RIGHT-OF-WAYS.
- STABILIZED CONSTRUCTION ENTRANCE/EXIT SHALL BE INSTALLED PRIOR TO ANY LAND DISTURBING ACTIVITIES.
- A NON-WOVEN GEOTEXTILE FABRIC SHALL BE PLACED UNDER THE STABILIZED CONSTRUCTION ENTRANCE/EXIT PRIOR TO THE PLACEMENT OF ROCK.
- UNLESS OTHERWISE SPECIFIED BY LOCAL JURISDICTION, ROCK SHALL CONSIST OF DOT SECT. #703, AASHTO #3 COARSE AGGREGATE OR 6" (MINUS) ROCK.

**STABILIZED CONSTRUCTION ENTRANCE/EXIT MAINTENANCE NOTES**

- INSPECT BMPs EACH WORKDAY, AND MAINTAIN THEM IN EFFECTIVE OPERATING CONDITION. MAINTENANCE OF BMPs SHOULD BE PROACTIVE, NOT REACTIVE. INSPECT BMPs AS SOON AS POSSIBLE (AND ALWAYS WITHIN 24 HOURS) FOLLOWING A STORM THAT CAUSES SURFACE EROSION, AND PERFORM NECESSARY MAINTENANCE.
  - FREQUENT OBSERVATIONS AND MAINTENANCE ARE NECESSARY TO MAINTAIN BMPs IN EFFECTIVE OPERATING CONDITION. INSPECTIONS AND CORRECTIVE MEASURES SHOULD BE DOCUMENTED THOROUGHLY.
  - WHERE BMPs HAVE FAILED, REPAIR OR REPLACEMENT SHOULD BE INITIATED UPON DISCOVERY OF THE FAILURE.
  - ROCK SHALL BE REAPPLIED OR REGRADED AS NECESSARY TO THE STABILIZED ENTRANCE/EXIT TO MAINTAIN A CONSISTENT DEPTH.
  - SEDIMENT TRACKED ONTO PAVED ROADS IS TO BE REMOVED THROUGHOUT THE DAY AND AT THE END OF THE DAY BY SHOVELING OR SWEEPING. SEDIMENT MAY NOT BE WASHED DOWN STORM SEWER DRAINS.
- NOTE: MANY JURISDICTIONS HAVE BMP DETAILS THAT VARY FROM UDFCD STANDARD DETAILS. CONSULT WITH LOCAL JURISDICTIONS AS TO WHICH DETAIL SHOULD BE USED WHEN DIFFERENCES ARE NOTED.
- (DETAILS ADAPTED FROM CITY OF BROOMFIELD, COLORADO, NOT AVAILABLE IN AUTOCAD)

VTC-6 Urban Drainage and Flood Control District  
Urban Storm Drainage Criteria Manual Volume 3 November 2010

**Stabilized Staging Area (SSA) SM-6**

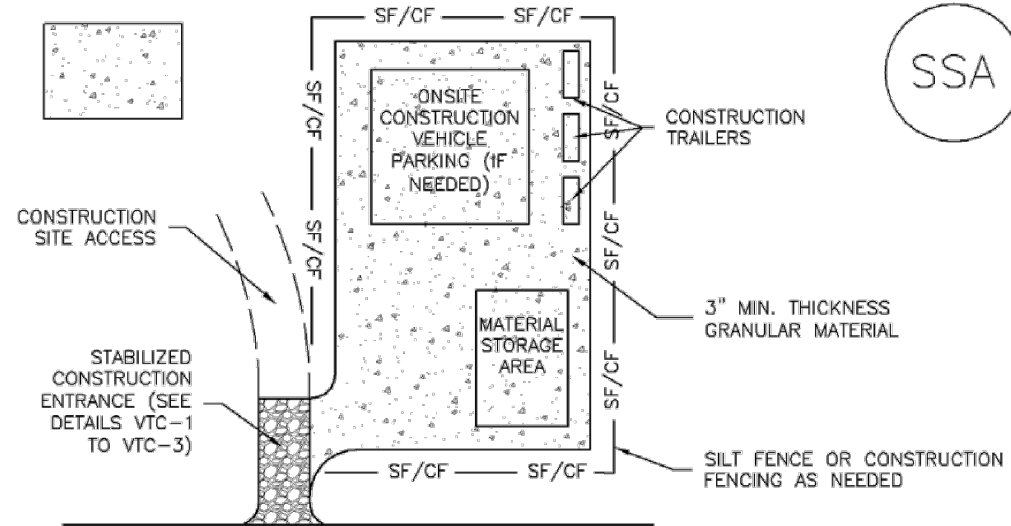

**SSA-1. STABILIZED STAGING AREA**

**STABILIZED STAGING AREA INSTALLATION NOTES**

- SEE PLAN VIEW FOR:
  - LOCATION OF STAGING AREA(S).
  - CONTRACTOR MAY ADJUST LOCATION AND SIZE OF STAGING AREA WITH APPROVAL FROM THE LOCAL JURISDICTION.
- STABILIZED STAGING AREA SHOULD BE APPROPRIATE FOR THE NEEDS OF THE SITE. OVERSIZING RESULTS IN A LARGER AREA TO STABILIZE FOLLOWING CONSTRUCTION.
- STAGING AREA SHALL BE STABILIZED PRIOR TO OTHER OPERATIONS ON THE SITE.
- THE STABILIZED STAGING AREA SHALL CONSIST OF A MINIMUM 3" THICK GRANULAR MATERIAL.
- UNLESS OTHERWISE SPECIFIED BY LOCAL JURISDICTION, ROCK SHALL CONSIST OF DOT SECT. #703, AASHTO #3 COARSE AGGREGATE OR 6" (MINUS) ROCK.
- ADDITIONAL PERIMETER BMPs MAY BE REQUIRED INCLUDING BUT NOT LIMITED TO SILT FENCE AND CONSTRUCTION FENCING.

**STABILIZED STAGING AREA MAINTENANCE NOTES**

- INSPECT BMPs EACH WORKDAY, AND MAINTAIN THEM IN EFFECTIVE OPERATING CONDITION. MAINTENANCE OF BMPs SHOULD BE PROACTIVE, NOT REACTIVE. INSPECT BMPs AS SOON AS POSSIBLE (AND ALWAYS WITHIN 24 HOURS) FOLLOWING A STORM THAT CAUSES SURFACE EROSION, AND PERFORM NECESSARY MAINTENANCE.
- FREQUENT OBSERVATIONS AND MAINTENANCE ARE NECESSARY TO MAINTAIN BMPs IN EFFECTIVE OPERATING CONDITION. INSPECTIONS AND CORRECTIVE MEASURES SHOULD BE DOCUMENTED THOROUGHLY.
- WHERE BMPs HAVE FAILED, REPAIR OR REPLACEMENT SHOULD BE INITIATED UPON DISCOVERY OF THE FAILURE.
- ROCK SHALL BE REAPPLIED OR REGRADED AS NECESSARY IF RUTTING OCCURS OR UNDERLYING SUBGRADE BECOMES EXPOSED.

November 2010 Urban Drainage and Flood Control District  
Urban Storm Drainage Criteria Manual Volume 3 SSA-3

**SM-6 Stabilized Staging Area (SSA)**

**Minimizing Long-Term Stabilization Requirements**

- Utilize off-site parking and restrict vehicle access to the site.
- Use construction mats in lieu of rock when staging is provided in an area that will not be disturbed otherwise.
- Consider use of a bermed contained area for materials and equipment that do not require a stabilized surface.
- Consider phasing of staging areas to avoid disturbance in an area that will not be otherwise disturbed.

See Detail SSA-1 for a typical stabilized staging area and SSA-2 for a stabilized staging area when materials staging in roadways is required.

**Maintenance and Removal**

Maintenance of stabilized staging areas includes maintaining a stable surface cover of gravel, repairing perimeter controls, and following good housekeeping practices.

When construction is complete, debris, unused stockpiles and materials should be recycled or properly disposed. In some cases, this will require disposal of contaminated soil from equipment leaks in an appropriate landfill. Staging areas should then be permanently stabilized with vegetation or other surface cover planned for the development.

SSA-2 Urban Drainage and Flood Control District  
Urban Storm Drainage Criteria Manual Volume 3 November 2010

**SM-6 Stabilized Staging Area (SSA)**

**STABILIZED STAGING AREA MAINTENANCE NOTES**

- STABILIZED STAGING AREA SHALL BE ENLARGED IF NECESSARY TO CONTAIN PARKING, STORAGE, AND UNLOADING/LOADING OPERATIONS.
  - THE STABILIZED STAGING AREA SHALL BE REMOVED AT THE END OF CONSTRUCTION. THE GRANULAR MATERIAL SHALL BE REMOVED OR, IF APPROVED BY THE LOCAL JURISDICTION, USED ON SITE, AND THE AREA COVERED WITH TOPSOIL, SEEDING AND MULCHED OR OTHERWISE STABILIZED IN A MANNER APPROVED BY LOCAL JURISDICTION.
- NOTE: MANY MUNICIPALITIES PROHIBIT THE USE OF RECYCLED CONCRETE AS GRANULAR MATERIAL FOR STABILIZED STAGING AREAS DUE TO DIFFICULTIES WITH RE-ESTABLISHMENT OF VEGETATION IN AREAS WHERE RECYCLED CONCRETE WAS PLACED.
- NOTE: MANY JURISDICTIONS HAVE BMP DETAILS THAT VARY FROM UDFCD STANDARD DETAILS. CONSULT WITH LOCAL JURISDICTIONS AS TO WHICH DETAIL SHOULD BE USED WHEN DIFFERENCES ARE NOTED.
- (DETAILS ADAPTED FROM DOUGLAS COUNTY, COLORADO, NOT AVAILABLE IN AUTOCAD)

SSA-4 Urban Drainage and Flood Control District  
Urban Storm Drainage Criteria Manual Volume 3 November 2010

**Rolled Erosion Control Products (RECP) EC-6**

Staking patterns are also provided in the design details according to these factors:

- ECB type
- Slope or channel type

For other types of RECPs including TRMs, these design details are intended to serve as general guidelines for design and installation; however, engineers should adhere to manufacturer's installation recommendations.

**Maintenance and Removal**

Inspection of erosion control blankets and other RECPs includes:

- Check for general signs of erosion, including voids beneath the mat. If voids are apparent, fill the void with suitable soil and replace the erosion control blanket, following the appropriate staking pattern.
- Check for damaged or loose stakes and secure loose portions of the blanket.

Erosion control blankets and other RECPs that are biodegradable typically do not need to be removed after construction. If they must be removed, then an alternate soil stabilization method should be installed promptly following removal.

Turf reinforcement mats, although generally resistant to biodegradation, are typically left in place as a dense vegetated cover grows in through the mat matrix. The turf reinforcement mat provides long-term stability and helps the established vegetation resist erosive forces.

November 2010 Urban Drainage and Flood Control District  
Urban Storm Drainage Criteria Manual Volume 3 RECP-5

**Rolled Erosion Control Products (RECP) EC-6**

**EROSION CONTROL BLANKET MAINTENANCE NOTES**

- INSPECT BMPs EACH WORKDAY, AND MAINTAIN THEM IN EFFECTIVE OPERATING CONDITION. MAINTENANCE OF BMPs SHOULD BE PROACTIVE, NOT REACTIVE. INSPECT BMPs AS SOON AS POSSIBLE (AND ALWAYS WITHIN 24 HOURS) FOLLOWING A STORM THAT CAUSES SURFACE EROSION, AND PERFORM NECESSARY MAINTENANCE.
  - FREQUENT OBSERVATIONS AND MAINTENANCE ARE NECESSARY TO MAINTAIN BMPs IN EFFECTIVE OPERATING CONDITION. INSPECTIONS AND CORRECTIVE MEASURES SHOULD BE DOCUMENTED THOROUGHLY.
  - WHERE BMPs HAVE FAILED, REPAIR OR REPLACEMENT SHOULD BE INITIATED UPON DISCOVERY OF THE FAILURE.
  - ECBs SHALL BE LEFT IN PLACE TO EVENTUALLY BIODEGRADE, UNLESS REQUESTED TO BE REMOVED BY THE LOCAL JURISDICTION.
  - ANY ECB PULLED OUT, TORN, OR OTHERWISE DAMAGED SHALL BE REPAIRED OR REINSTALLED. ANY SUBGRADE AREAS BELOW THE GEOTEXTILE THAT HAVE ERODED TO CREATED A VOID UNDER THE BLANKET, OR THAT REMAIN DEVOID OF GRASS SHALL BE REPAIRED, RESEEDED AND MULCHED AND THE ECB REINSTALLED.
- NOTE: MANY JURISDICTIONS HAVE BMP DETAILS THAT VARY FROM UDFCD STANDARD DETAILS. CONSULT WITH LOCAL JURISDICTIONS AS TO WHICH DETAIL SHOULD BE USED WHEN DIFFERENCES ARE NOTED.
- (DETAILS ADAPTED FROM DOUGLAS COUNTY, COLORADO AND TOWN OF PARKER, COLORADO, NOT AVAILABLE IN AUTOCAD)

November 2010 Urban Drainage and Flood Control District  
Urban Storm Drainage Criteria Manual Volume 3 RECP-9

**T-6 Sand Filter**

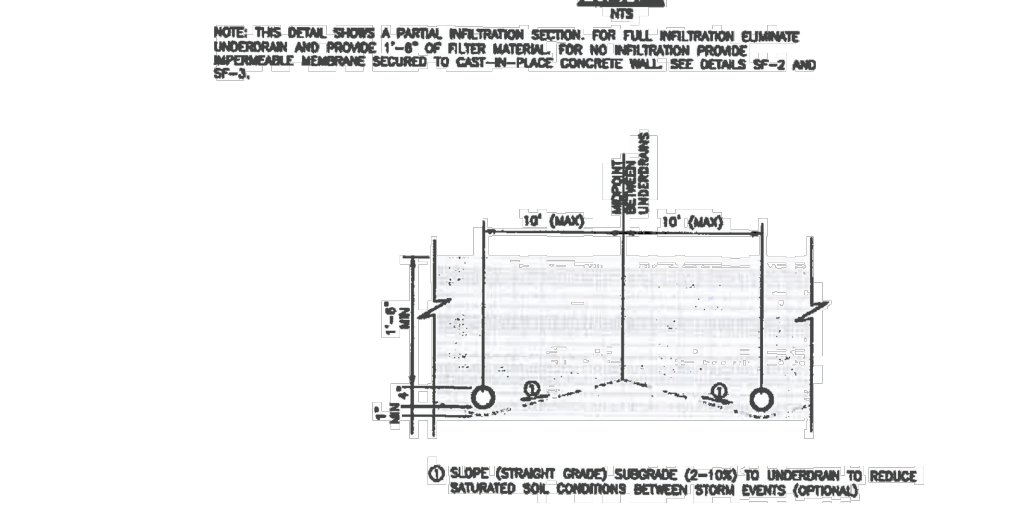
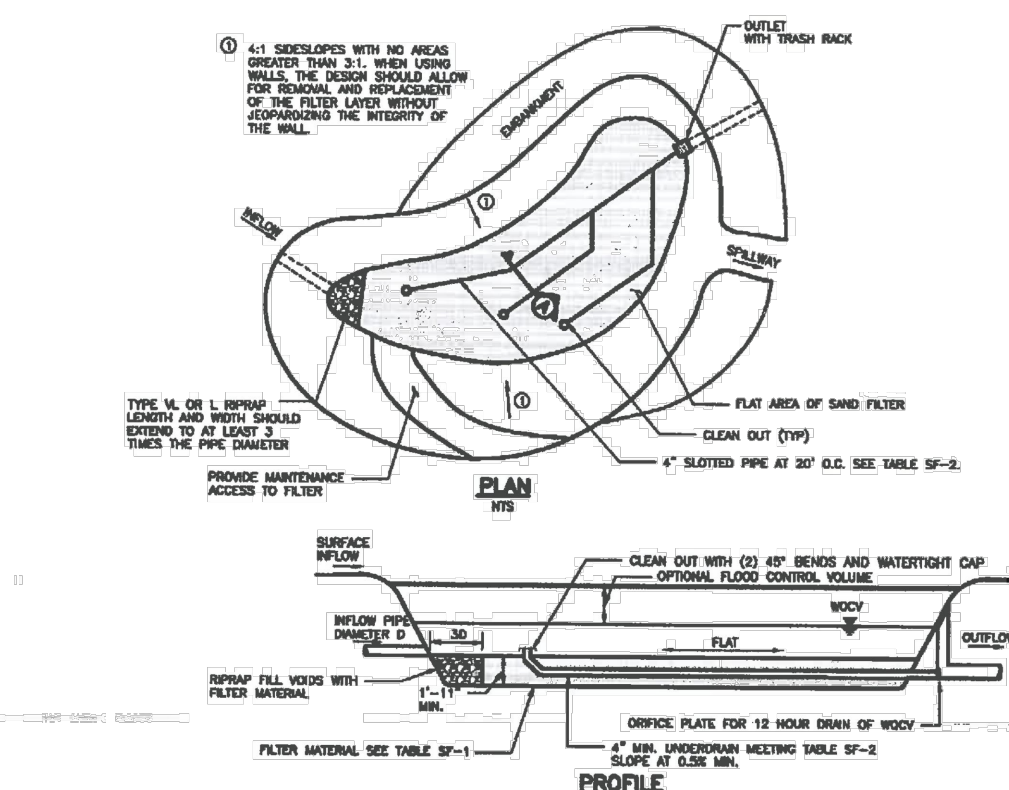

**Figure SF-1. Sand Filter Plan and Sections**

SF-8 Urban Drainage and Flood Control District  
Urban Storm Drainage Criteria Manual Volume 3 November 2015

**SM-6 Stabilized Staging Area (SSA)**

**STABILIZED STAGING AREA MAINTENANCE NOTES**

- STABILIZED STAGING AREA SHALL BE ENLARGED IF NECESSARY TO CONTAIN PARKING, STORAGE, AND UNLOADING/LOADING OPERATIONS.
  - THE STABILIZED STAGING AREA SHALL BE REMOVED AT THE END OF CONSTRUCTION. THE GRANULAR MATERIAL SHALL BE REMOVED OR, IF APPROVED BY THE LOCAL JURISDICTION, USED ON SITE, AND THE AREA COVERED WITH TOPSOIL, SEEDING AND MULCHED OR OTHERWISE STABILIZED IN A MANNER APPROVED BY LOCAL JURISDICTION.
- NOTE: MANY MUNICIPALITIES PROHIBIT THE USE OF RECYCLED CONCRETE AS GRANULAR MATERIAL FOR STABILIZED STAGING AREAS DUE TO DIFFICULTIES WITH RE-ESTABLISHMENT OF VEGETATION IN AREAS WHERE RECYCLED CONCRETE WAS PLACED.
- NOTE: MANY JURISDICTIONS HAVE BMP DETAILS THAT VARY FROM UDFCD STANDARD DETAILS. CONSULT WITH LOCAL JURISDICTIONS AS TO WHICH DETAIL SHOULD BE USED WHEN DIFFERENCES ARE NOTED.
- (DETAILS ADAPTED FROM DOUGLAS COUNTY, COLORADO, NOT AVAILABLE IN AUTOCAD)

SSA-4 Urban Drainage and Flood Control District  
Urban Storm Drainage Criteria Manual Volume 3 November 2010

**Rolled Erosion Control Products (RECP) EC-6**

Staking patterns are also provided in the design details according to these factors:

- ECB type
- Slope or channel type

For other types of RECPs including TRMs, these design details are intended to serve as general guidelines for design and installation; however, engineers should adhere to manufacturer's installation recommendations.

**Maintenance and Removal**

Inspection of erosion control blankets and other RECPs includes:

- Check for general signs of erosion, including voids beneath the mat. If voids are apparent, fill the void with suitable soil and replace the erosion control blanket, following the appropriate staking pattern.
- Check for damaged or loose stakes and secure loose portions of the blanket.

Erosion control blankets and other RECPs that are biodegradable typically do not need to be removed after construction. If they must be removed, then an alternate soil stabilization method should be installed promptly following removal.

Turf reinforcement mats, although generally resistant to biodegradation, are typically left in place as a dense vegetated cover grows in through the mat matrix. The turf reinforcement mat provides long-term stability and helps the established vegetation resist erosive forces.

November 2010 Urban Drainage and Flood Control District  
Urban Storm Drainage Criteria Manual Volume 3 RECP-5

**Rolled Erosion Control Products (RECP) EC-6**

**EROSION CONTROL BLANKET MAINTENANCE NOTES**

- INSPECT BMPs EACH WORKDAY, AND MAINTAIN THEM IN EFFECTIVE OPERATING CONDITION. MAINTENANCE OF BMPs SHOULD BE PROACTIVE, NOT REACTIVE. INSPECT BMPs AS SOON AS POSSIBLE (AND ALWAYS WITHIN 24 HOURS) FOLLOWING A STORM THAT CAUSES SURFACE EROSION, AND PERFORM NECESSARY MAINTENANCE.
  - FREQUENT OBSERVATIONS AND MAINTENANCE ARE NECESSARY TO MAINTAIN BMPs IN EFFECTIVE OPERATING CONDITION. INSPECTIONS AND CORRECTIVE MEASURES SHOULD BE DOCUMENTED THOROUGHLY.
  - WHERE BMPs HAVE FAILED, REPAIR OR REPLACEMENT SHOULD BE INITIATED UPON DISCOVERY OF THE FAILURE.
  - ECBs SHALL BE LEFT IN PLACE TO EVENTUALLY BIODEGRADE, UNLESS REQUESTED TO BE REMOVED BY THE LOCAL JURISDICTION.
  - ANY ECB PULLED OUT, TORN, OR OTHERWISE DAMAGED SHALL BE REPAIRED OR REINSTALLED. ANY SUBGRADE AREAS BELOW THE GEOTEXTILE THAT HAVE ERODED TO CREATED A VOID UNDER THE BLANKET, OR THAT REMAIN DEVOID OF GRASS SHALL BE REPAIRED, RESEEDED AND MULCHED AND THE ECB REINSTALLED.
- NOTE: MANY JURISDICTIONS HAVE BMP DETAILS THAT VARY FROM UDFCD STANDARD DETAILS. CONSULT WITH LOCAL JURISDICTIONS AS TO WHICH DETAIL SHOULD BE USED WHEN DIFFERENCES ARE NOTED.
- (DETAILS ADAPTED FROM DOUGLAS COUNTY, COLORADO AND TOWN OF PARKER, COLORADO, NOT AVAILABLE IN AUTOCAD)

November 2010 Urban Drainage and Flood Control District  
Urban Storm Drainage Criteria Manual Volume 3 RECP-9

**Sand Filter T-6**

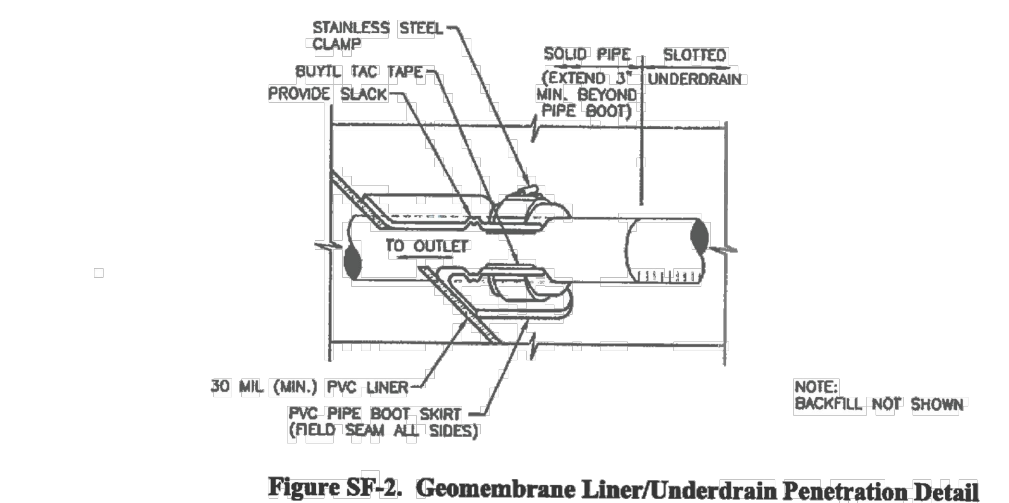

**Figure SF-2. Geomembrane Liner/Underdrain Penetration Detail**

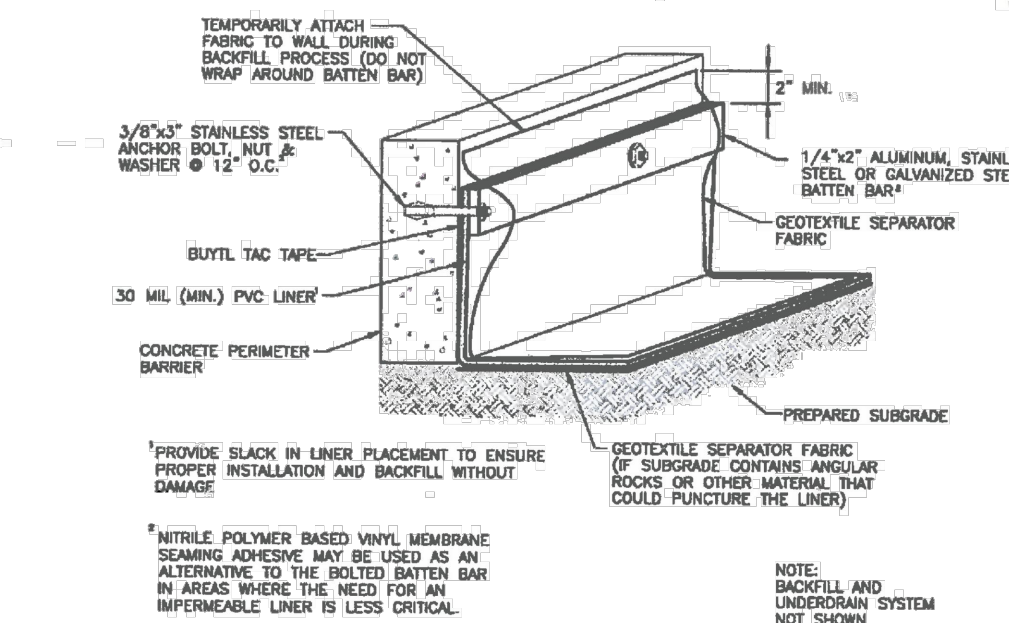

**Figure SF-3. Geomembrane Liner/Concrete Connection Detail**

November 2015 Urban Drainage and Flood Control District  
Urban Storm Drainage Criteria Manual Volume 3 SF-9

**HOMESTEAD AT STERLING RANCH FILING NO. 2**

**GRADING & EROSION CONTROL DETAILS**

PROJECT NO. 09-007 DATE: 03-23-2020

SCALE: HORIZONTAL: N/A VERTICAL: N/A

DESIGNED BY: DLM DRAWN BY: JWP CHECKED BY: VAS

SHEET 7 OF 8 FGR07

102 E. Pikes Peak Ave., 5th Floor  
Colorado Springs, CO 80903  
PHONE: 719.555.5485

**CIVIL CONSULTANTS, INC.**

FOR AND ON BEHALF OF M&S CIVIL CONSULTANTS, INC.

MIRCEL A. SANCHEZ, COLORADO P.E. NO. 37160

PROFESSIONAL ENGINEER

NO. DATE: BY: DESCRIPTION:

THE ENGINEER PREPARING THESE PLANS WILL NOT BE RESPONSIBLE FOR UNAUTHORIZED CHANGES TO OR USES OF THESE PLANS. ALL CHANGES TO THE PLANS MUST BE IN WRITING AND MUST BE APPROVED BY THE PREPARER OF THESE PLANS.

CAUTION



**EC-6 Rolled Erosion Control Products (RECP)**

**Turf Reinforcement Mat (TRM):** A rolled erosion control product composed of non-degradable synthetic fibers, filaments, nets, wire mesh, and/or other elements, processed into a permanent, three-dimensional matrix of sufficient thickness. TRMs, which may be supplemented with degradable components, are designed to impart immediate erosion protection, enhance vegetation establishment and provide long-term functionality by permanently reinforcing vegetation during and after maturation. Note: TRMs are typically used in hydraulic applications, such as high flow ditches and channels, steep slopes, stream banks, and shorelines, where erosive forces may exceed the limits of natural, unreinforced vegetation or in areas where limited vegetation establishment is anticipated.

Tables RECP-1 and RECP-2 provide guidelines for selecting rolled erosion control products appropriate to site conditions and desired longevity. Table RECP-1 is for conditions where natural vegetation alone will provide permanent erosion control, whereas Table RECP-2 is for conditions where vegetation alone will not be adequately stable to provide long-term erosion protection due to flow or other conditions.

RECP-2 Urban Drainage and Flood Control District  
Urban Storm Drainage Criteria Manual Volume 3 November 2010

**Roller Erosion Control Products (RECP) EC-6**

**Table RECP-1. ECTC Standard Specification for Temporary Rolled Erosion Control Products**  
(Adapted from Erosion Control Technology Council 2005)

Product Description	Slope Applications*		Channel Applications*	Minimum Tensile Strength <sup>1</sup>	Expected Longevity
	Maximum Gradient	C Factor <sup>2,5</sup>			
Mulch Control Nets	5:1 (H:V)	≤0.10 @ 5:1	0.25 lbs/ft <sup>2</sup> (12 Pa)	5 lbs/ft (0.073 kN/m)	Up to 12 months
Netless Rolled Erosion Control Blankets	4:1 (H:V)	≤0.10 @ 4:1	0.5 lbs/ft <sup>2</sup> (24 Pa)	5 lbs/ft (0.073 kN/m)	
Single-net Erosion Control Blankets & Open Weave Textiles	3:1 (H:V)	≤0.15 @ 3:1	1.5 lbs/ft <sup>2</sup> (72 Pa)	50 lbs/ft (0.73 kN/m)	
Double-net Erosion Control Blankets	2:1 (H:V)	≤0.20 @ 2:1	1.75 lbs/ft <sup>2</sup> (84 Pa)	75 lbs/ft (1.09 kN/m)	
Mulch Control Nets	5:1 (H:V)	≤0.10 @ 5:1	0.25 lbs/ft <sup>2</sup> (12 Pa)	25 lbs/ft (0.36 kN/m)	24 months
Erosion Control Blankets & Open Weave Textiles (slowly degrading)	1.5:1 (H:V)	≤0.25 @ 1.5:1	2.00 lbs/ft <sup>2</sup> (96 Pa)	100 lbs/ft (1.45 kN/m)	24 months
Erosion Control Blankets & Open Weave Textiles	1:1 (H:V)	≤0.25 @ 1:1	2.25 lbs/ft <sup>2</sup> (108 Pa)	125 lbs/ft (1.82 kN/m)	36 months

\* C Factor and shear stress for mulch control nettings must be obtained with netting used in conjunction with pre-applied mulch material. (See Section 5.3 of Chapter 7 Construction BMPs for more information on the C Factor.)

<sup>1</sup> Minimum Average Roll Values, Machine direction using ECTC Mod. ASTM D 5035.

<sup>2</sup> C Factor calculated as ratio of soil loss from RECP protected slope (tested at specified or greater gradient, H:V) to ratio of soil loss from unprotected (control) plot in large-scale testing.

<sup>3</sup> Required minimum shear stress RECP (unvegetated) can sustain without physical damage or excess erosion (> 12.7 mm (0.5 in) soil loss) during a 30-minute flow event in large-scale testing.

<sup>4</sup> The permissible shear stress levels established for each performance category are based on historical experience with products characterized by Manning's roughness coefficients in the range of 0.01 - 0.05.

<sup>5</sup> Acceptable large-scale test methods may include ASTM D 6459, or other independent testing deemed acceptable by the engineer.

<sup>6</sup> Per the engineer's discretion. Recommended acceptable large-scale testing protocol may include ASTM D 6460, or other independent testing deemed acceptable by the engineer.

RECP-3 Urban Drainage and Flood Control District  
Urban Storm Drainage Criteria Manual Volume 3 November 2010

**EC-6 Rolled Erosion Control Products (RECP)**

**Table RECP-2. ECTC Standard Specification for Permanent Rolled Erosion Control Products**  
(Adapted from Erosion Control Technology Council 2005)

Product Type	Slope Applications		Channel Applications	
	Maximum Gradient	Minimum Tensile Strength <sup>1,2,3</sup>	Maximum Shear Stress <sup>5</sup>	Minimum Tensile Strength <sup>1,2,3</sup>
TRMs with a minimum thickness of 0.25 inches (6.35 mm) per ASTM D 6525 and UV stability of 80% per ASTM D 4355 (500 hours exposure).	0.5:1 (H:V)	125 lbs/ft (1.82 kN/m)	6.0 lbs/ft <sup>2</sup> (288 Pa)	125 lbs/ft (1.82 kN/m)
	0.5:1 (H:V)	150 lbs/ft (2.19 kN/m)	8.0 lbs/ft <sup>2</sup> (384 Pa)	150 lbs/ft (2.19 kN/m)
	0.5:1 (H:V)	175 lbs/ft (2.55 kN/m)	10.0 lbs/ft <sup>2</sup> (480 Pa)	175 lbs/ft (2.55 kN/m)

<sup>1</sup> For TRMs containing degradable components, all property values must be obtained on the non-degradable portion of the matting alone.

<sup>2</sup> Minimum Average Roll Values, machine direction only for tensile strength determination using ASTM D 6818 (Supersedes Mod. ASTM D 5035 for RECPs).

<sup>3</sup> Field conditions with high loading and/or high survivability requirements may warrant the use of a TRM with a tensile strength of 44 kN/m (3,000 lb/ft) or greater.

<sup>4</sup> Required minimum shear stress TRM (fully vegetated) can sustain without physical damage or excess erosion (> 12.7 mm (0.5 in) soil loss) during a 30-minute flow event in large scale testing.

<sup>5</sup> Acceptable large-scale test methods may include ASTM D 6460, or other independent testing deemed acceptable by the engineer.

**Design and Installation**

RECPs should be installed according to manufacturer's specifications and guidelines. Regardless of the type of product used, it is important to ensure no gaps or voids exist under the material and that all corners of the material are secured using stakes and trenching. Continuous contact between the product and the soil is necessary to avoid failure. Never use metal stakes to secure temporary erosion control products. Often wooden stakes are used to anchor RECPs; however, wood stakes may present installation and maintenance challenges and generally take a long time to biodegrade. Some local jurisdictions have had favorable experiences using biodegradable stakes.

This BMP Fact Sheet provides design details for several commonly used ECB applications, including:

ECB-1 Pipe Outlet to Drainageway  
ECB-2 Small Ditch or Drainageway  
ECB-3 Outside of Drainageway

RECP-4 Urban Drainage and Flood Control District  
Urban Storm Drainage Criteria Manual Volume 3 November 2010

**EC-6 Rolled Erosion Control Products (RECP)**

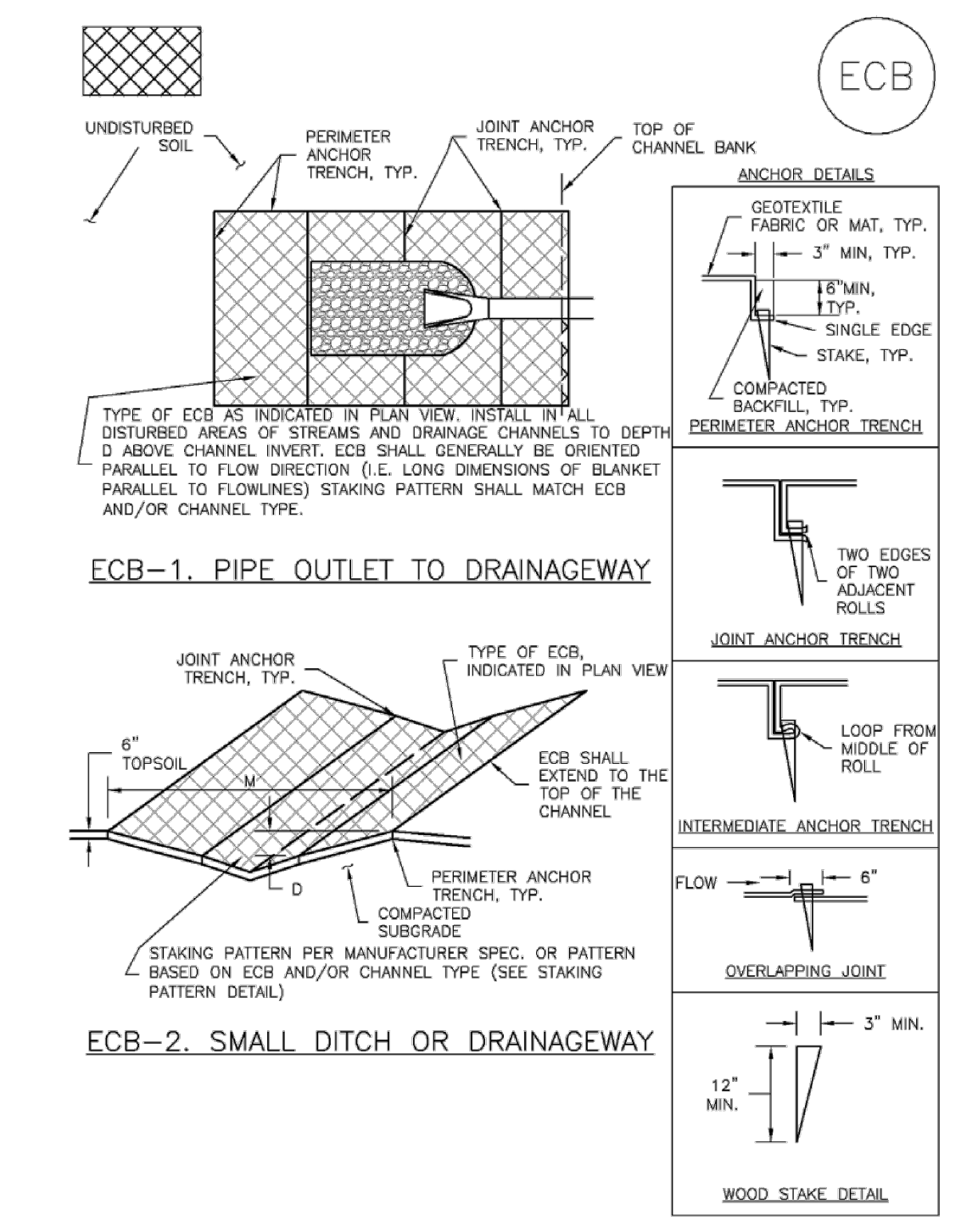

RECP-6 Urban Drainage and Flood Control District  
Urban Storm Drainage Criteria Manual Volume 3 November 2010

**Roller Erosion Control Products (RECP) EC-6**

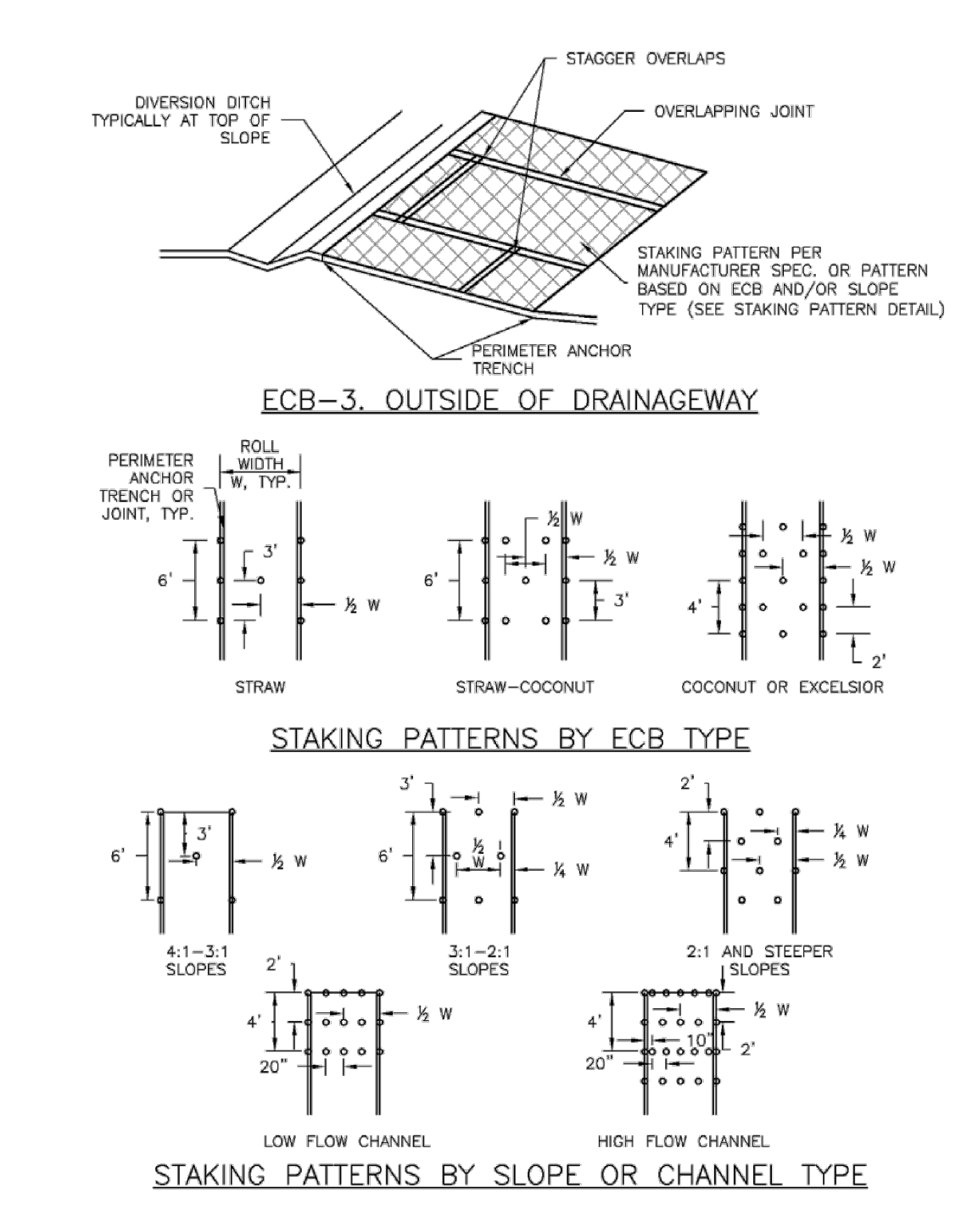

RECP-7 Urban Drainage and Flood Control District  
Urban Storm Drainage Criteria Manual Volume 3 November 2010

**EC-6 Rolled Erosion Control Products (RECP)**

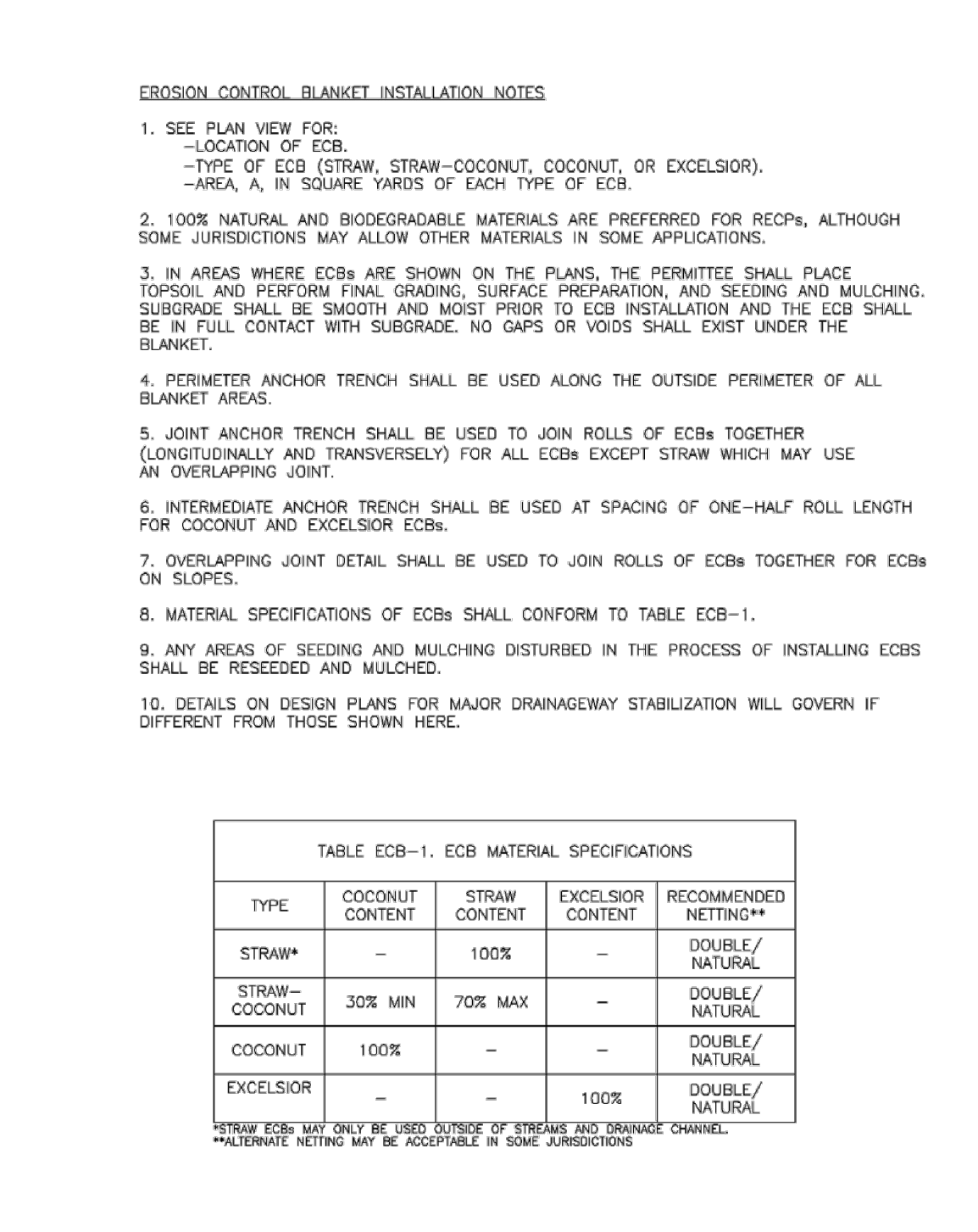

RECP-8 Urban Drainage and Flood Control District  
Urban Storm Drainage Criteria Manual Volume 3 November 2010

**Extended Detention Basin (EDB) T-5**

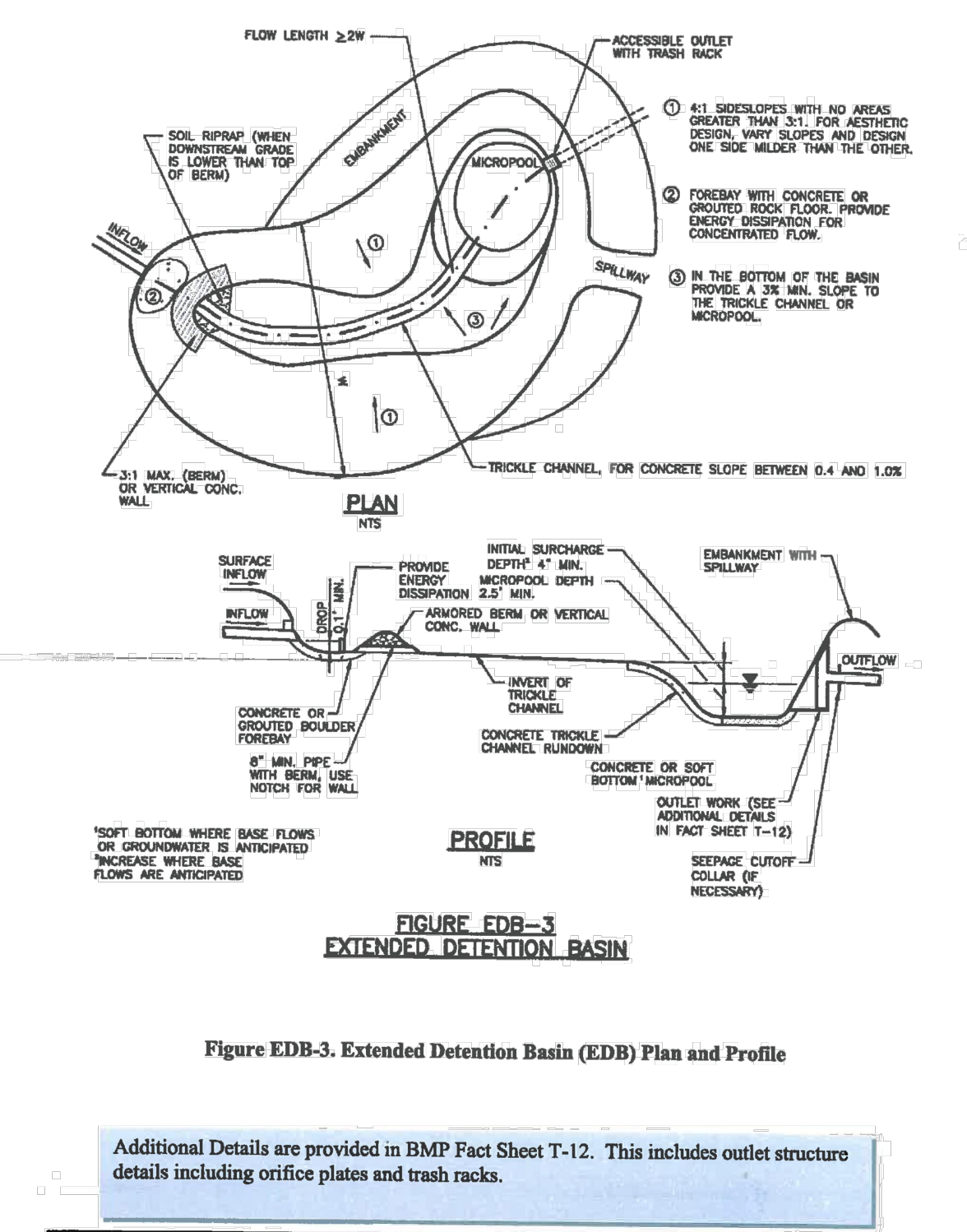

RECP-11 Urban Drainage and Flood Control District  
Urban Storm Drainage Criteria Manual Volume 3 November 2015

**HOMESTEAD AT STERLING RANCH FILING NO. 2**

**GRADING & EROSION CONTROL DETAILS**

PROJECT NO. 09-007  
DATE: 03-23-2020  
SCALE: N/A  
DESIGNED BY: DLM  
DRAWN BY: JWP  
CHECKED BY: VAS

102 E. Pikes Peak Ave., 5th Floor  
Colorado Springs, CO 80903  
PHONE: 719.555.4485

**CIVIL CONSULTANTS, INC.**

FOR AND ON BEHALF OF M&S CIVIL CONSULTANTS, INC.

PROFESSIONAL SEAL: MARGIE A. SANCHEZ, COLORADO P.E. NO. 37160

NO. DATE: BY: DESCRIPTION:

FOR LOCATING & MARKING GAS, ELECTRIC, WATER & TELEPHONE LINES  
FOR BURIED UTILITY INFORMATION  
CALL 1-800-922-1987

THE ENGINEER PREPARING THESE PLANS WILL NOT BE RESPONSIBLE OR LIABLE FOR UNAUTHORIZED CHANGES TO OR USES OF THESE PLANS. ALL CHANGES TO THE PLANS MUST BE IN WRITING AND MUST BE APPROVED BY THE PREPARER OF THESE PLANS.

CAUTION