



STORMWATER MANAGEMENT PLAN

FALCON MEADOWS AT BENT GRASS DRAINAGE CHANNEL IMPROVEMENTS

PCD FILING NO.:  **CDR2114**

STORMWATER PERMIT # COR _____
CERTIFICATION # _____

Owner/Developer:

Challenger Communities, LLC
8605 Explorer Drive, Suite 250
Colorado Springs, CO 80920

SWMP Preparer:

Galloway & Company, Inc.
1155 Kelly Johnson Blvd., Suite 305
Colorado Springs, CO 80918

Contractor:

To be Determined

**SWMP Administrator / Qualified
Stormwater Manager:**

To be Determined

Date:

Prepared: September 20, 2021

SWMP Location:

On-Site (Copy) and Challenger Homes
(Original)



TABLE OF CONTENTS

SWMP REPORT REVISION LOG

I. PROJECT DESCRIPTION.....	4
II. PHASING AND PROPOSED CONSTRUCTION SEQUENCE.....	4
III. FINAL STABILIZATION	5
IV. PRE-DEVELOPMENT CONDITIONS & SOILS	5
V. DESCRIPTION OF POTENTIAL POLLUTANTS	7
VI. AREAS AND VOLUMES.....	10
VII. APPROPRIATE CONTROLS AND MEASURES	11
VIII. MATERIALS HANDLING AND SPILL PREVENTION	14
X. RECEIVING WATERS.....	17
IX. INSPECTION AND RECORD KEEPING	17

Appendices:

- A. Vicinity Map
- B. Soils Map
- C. FEMA Map
- D. GESCP Plan
- E. BMP Details
- F. ESQCP

SWMP REPORT REVISION LOG

REVISION #	DATE	BY	COMMENTS
1.			
2.			
3.			
4.			
5.			
6.			
7.			
8.			
9.			
10.			
11.			
12.			
13.			

I. PROJECT DESCRIPTION

LOCATION

Falcon Meadows at Bent Grass Channel Improvements is located in the West half of Section 1, Township 13 South, Range 65 West of the 6th Principle Meridian, County of El Paso, State of Colorado. The project site is bounded East by Bent Grass Residential Filing No. 2, North by The Meadows Filing No. 2, West, by The Meadows Filing No. 3, and South by Latigo Business Center Filing No. 1.

LEGAL DESCRIPTION

The legal description of Falcon Meadows at Bent Grass Drainage Channel is:

DESCRIPTION OF PROPERTY

The project site contains approximately 16.4 acres and is comprised of an unnamed tributary of the Back Squirrel Creek and is also referred to as the northern portion of the West Tributary of the Falcon Basin.

CONSTRUCTION ACTIVITY

Construction activities include but are not limited to channel realignment, channel grading, relocation of any existing utilities which may conflict with any of the channel improvements.

Temporary stabilization measures (silt fence) will be installed prior to beginning construction. During construction, temporary stabilization measures, including inlet protection, will be utilized to control stormwater runoff. Once final stabilization is achieved, temporary erosion control measures will be removed.

II. PHASING AND PROPOSED CONSTRUCTION SEQUENCE

PHASING

Construction activities will be completed in three phases, Initial, interim and final. Initial phase includes the installation of silt fence around the entire project's Limit of Disturbance area, and inlet protection around existing inlets. Interim phase includes the installation of temporary sediment controls as construction progresses. The final phase will be completed once the site is stabilized and all temporary measures are removed.

CONSTRUCTION DOCUMENTATION

Construction drawings are provided with this document showing each of these phases and are intended to be a "living" document used by the SWMP Manager to document construction activities. See section IX "Inspection and Record Keeping" for additional information.

PROPOSED SEQUENCE FOR MAJOR CONSTRUCTION ACTIVITIES

Construction for the development of this project is currently projected to begin in May of 2022. It is estimated that construction activities will be completed by December 2022. Final stabilization is expected in the spring of 2023. The anticipated sequence of construction is as follows:

Initial:

1. Installation of perimeter silt fence as shown on the grading and erosion control plans.
2. Placement of inlet protection erosion control measures along existing roadways.
3. Placement of curb socks along existing roadways.

Interim:

4. Site Clearing/Grubbing and topsoil stockpiling.
5. Construct Stabilized Staging Area as shown on the grading and erosion control plans.
6. Install Vehicle Tracking Control at entrances as shown on the grading and erosion control plans.
7. Rough grading of the site.

Final:

8. Construct grade control structures.
9. Final stabilize ROW.
10. Final erosion control measures as areas are completed. (Final BMP's)
11. Remove construction BMP's

See Section VI "Areas and Volumes" for information on anticipated disturbed area and grading volumes.

III. FINAL STABILIZATION

Final site stabilization will be achieved when all final landscaping and paving is complete and when vegetation density is greater than 70 percent of pre-disturbance density over the entire area. All final stabilization on the site will be of a permanent nature. All temporary BMPs will be removed upon completion of construction. It is the responsibility of the contractor to remove all dirt and garbage from the site.

Permanent BMP's will be owned and maintained by Bent Grass Metropolitan District.

IV. PRE-DEVELOPMENT CONDITIONS & SOILS

FLOODWAY

According to the current FEMA Flood Insurance Rate Map (FIRM) Panel No. 08041C0553 G, dated December 7, 2018 (See Appendix for the FEMA FIRM Exhibit) this site is designated as Zone AE (regulatory floodway). Falcon Meadows at Bent Grass proposes channel improvements to the Unnamed Tributary to Black Squirrel Creek No. 2, a permit is required and will be obtained from the El Paso County Floodplain Administrator prior to commencing work inside the "regulatory floodway". Per the El Paso County Floodplain Administrator, the floodway is classified as follows:

Riverine floodplain with base flood elevations, but no floodway: When the flood hazard map designates base flood elevations (100-year flood heights) but no floodway is

delineated, the applicant must demonstrate that the cumulative effect of the proposed development, when combined with all other existing and anticipated floodplain development, would not increase the water surface elevation of the 100-year flood more than one foot at any location.

EXISTING VEGETATION

Existing vegetation and soils were determined from in-person field site visits and existing aerial inspection from Google Earth and the United States Department of Agriculture Natural Resources Conservation Service (NRCS) Web Soil Survey. The site is currently undeveloped and has been used as a pasture for many years. Vegetation consists of native grasses/weeds that have been heavily grazed for years. There is no brush or trees within the area to be graded. Ground cover is estimated at 70% density.

EXISTING DRAINAGE PATTERNS

The site is fully contained within the West Falcon Tributary drainage basin. Drainage through the site is generally north to south. Drainage is collected in a wet weather conveyance known as “Unnamed Tributary to Black Squirrel Creek No. 2”. This wet weather conveyance flows north to south along the western border of Bent Grass Residential Filing No. 2.

EXISTING SLOPES

Existing slopes are around 1-10% that direct runoff to the Unnamed Tributary to Black Squirrel Creek No. 2. Construction of this development includes grading improvements and stabilization in the tributary south of Bent Grass Meadows Drive.

EXISTING SOIL TYPES

Soil data for Bent Grass Residential was obtained from the United States Department of Agriculture Natural Resources Conservation Service (NRCS) Web Soil Survey. The following table summarizes the characteristics of the soil type:

Soil	Hydro Group	Shrink/Swell Potential	Permeability		Surface Runoff Potential	Erosion Hazard
19-Columbine gravelly sandy loam, 0 to 3 percent slopes	A	Low	High		Very Low	Slight

The existing soil types have a slight potential for erosion which can be mitigated by employing appropriate downstream construction BMP's before/during/after construction to limit potential impacts to stormwater discharges. The potential impacts are sediment discharge into the existing wet weather conveyance and proposed storm sewer system. Sediment should not be allowed to enter these existing and proposed facilities and can be mitigated by constructing small temporary sediment basins at low points prior to discharge into the systems. Potential impacts from runoff flowing to the existing wet weather conveyance will be mitigated by constructing a temporary

sediment basin in the new pond location and by grading the site to reduce drainage area. Based upon the location of the different soil types and type of construction, the contractor shall employ the most appropriate method of erosion control measures based on the El Paso County/City of Colorado Springs Drainage Criteria Manual, Vol. 2 or as directed by the SWMP administrator or his representative.

More detailed soils information can be found in the SCS soils survey for El Paso County.

V. DESCRIPTION OF POTENTIAL POLLUTANTS

Potential sources of sediment to stormwater runoff include earth moving and concrete activities associated with grading and landscaping.

Potential pollutants and sources, other than sediment, to stormwater runoff include Trash, debris, line transfer, Dewatering, fueling and equipment failure.

A dewatering permit is not required

Construction activities produce many different kinds of pollutants which may cause storm water contamination problems. Grading activities remove rocks, vegetation and other erosion controlling surfaces, resulting in the exposure of underlying soil to the elements. Because the soil surface is unprotected, soil and sand particles are easily picked up by wind and/or washed away by rain or other water sources.

The following sections highlight the potential sources of pollution at the Project Site and list the “Best Management” strategies that will be used to prevent migration of pollution offsite. This Project Site does not rely on control measures owned or operated by another entity. Chemical materials stored indoors or that have no reasonable chance of impacting storm water quality will not be discussed in this plan.

Materials of significance stored on the project site include:

- Sediment
- Concrete Washout
- Cement
- Trash & Debris
- Sanitary Wastes
- Fuels & Oils

WIND EROSION & DUST CONTROL

Pollutant: Sediment Best Management Strategies:

- Daily inspections will occur for areas experiencing excessive winds, vehicle traffic, or precipitation events.

- Water trucks will spray down dust on the project Site as needed to not impact adjacent properties.
- Attention will be given to prevent the over-use of water in dust control operations to minimize any muddying of the surface and possible sediment transportation.

VEHICULAR TRANSPORT

Pollutant: Sediment Tracking Best Management Strategies:

- Construct a stabilized construction entrance to provide ingress and egress of the site.
- Restrict access to the stabilized construction entrance.
- Fencing will be erected if problems with access control are evident.
- Maintain track out pads by fluffing up the rock material or by adding additional rock as needed.
- Inspect, sweep and clean adjacent streets where track out is evident.

STOCKPILES

Pollutant: Sediment Best Management Strategies:

- Locate stockpiles clear of any water flow paths.
- Locate stockpiles within the property boundary.
- Stockpiles will have erosion control devices as needed installed around the base to prevent the migration of soil.
- Topsoil stock-piles and disturbed portions of the site where construction activity temporarily ceases for at least 14 days will be stabilized with temporary seed and mulch no later than 14 days from the last construction activity in the area.

GRADING, TRENCHING, EXPORT/IMPORT

Pollutant: Sediment Best management Strategies:

- Earth moving will be minimized by the engineering balancing of the site.
- Disturbed portions of the site where construction activity temporarily ceases for at least 14 days will be stabilized with temporary seed and mulch no later than 14 days from the last construction activity in the area.
- Seed bed preparation is not required if soil is in loose condition.
- Prior to seeding, fertilizer shall be applied to each acre to be stabilized in accordance with the manufacturer's specifications.
- If required seeding areas shall be mulched with straw to a uniformed cover. The straw mulch is to be tacked into place by a disk with blades set nearly straight.
- A site specific erosion control drawing has been developed showing the location of Best Management practices to be used during site construction.
- Where indicated on the erosion control plan, Best Management Practices will be installed.
- Material shall be in accordance with the plans and specifications and all construction shall be provided in accordance with the manufacturer's specifications.
- All BMP's will be inspected bi-weekly and cleaned/maintained as required.

WASTE, RESIDUAL CONCRETE

Pollutant: Concrete, paint, and Phosphoric Acid Best Management Strategies:

- A cleanup and washout area will be designated and posted.
- Subcontractors will be instructed on the locations and importance of the washout and cleanup areas. No on-site disposal is allowed.
- Instruct subcontractors to remove waste for which proper onsite disposal facilities are not provided back to their own facilities for ultimate transport, storage & disposal.
- Subcontractors and subcontractor employees are held responsible for improper washout.

SANITARY FACILITIES, TRASH CONTAINERS & LITTERING

Pollutant: Bacteria, Ammonia, Trash Best Management Strategies:

- Portable facilities will be regularly serviced to prevent excessive waste containment and overflow.
- Portable facilities will be located a minimum of 50 feet from state waters. They shall be adequately staked and cleaned on a weekly basis. They will be inspected daily for spills.
- All waste materials will be collected and stored in a container which will meet all local and any state solid waste management regulations.
- Trash dumpsters will be emptied prior to becoming 90% full or when debris control becomes an issue.
- Employees will be instructed on the importance of recycling and waste management and will be held responsible for improper waste management.

FUELING, HAZARDOUS MATERIALS, EQUIPMENT LEAKAGE, FERTILIZER

Pollutant: Petroleum Hydrocarbons, Ethylene Glycol, Sediment Best Management Strategies:

- MSDS sheets will be maintained in the project trailer for all onsite materials
- All dry materials such as cement will be covered and protected from rain.
- Secondary containment will be provided for stored fuel, oil, paint and any material classified as hazardous.
- Subcontractors are responsible for hazardous waste removal back to their own facilities for ultimate transportation, storage and disposal.
- Supplies will be kept onsite as necessary to control any potential spill.
- Employees will be held responsible for any illegal dumping.
- Seals will be checked by a qualified professional on all equipment and containers containing significant materials that could contribute potential pollutants and will be replaced as necessary.
- Equipment will be inspected by a qualified professional.
- Drip pans will be available for minor leaks and during fueling operations.
- Fueling nozzles, gauges, hoses, seals, and emergency shutoff valves will be inspected for leaks prior to use.
- Under no circumstances during fueling will the fueling hose/nozzle be left unattended.
- Fertilizers used will be applied only in the minimum amounts recommended by soil tests.

- Once applied, fertilizers will be worked into the soil to limit exposure to storm water.
- Stored fertilizer will be protected from exposure to precipitation and storm water runoff.

DEWATERING – not needed.

This shown for information only Pollutant: Sediment, Oil and/or Grease and Phosphoric Acid Best Management Strategies:

All dewatering will be filtered through rock and/or woven geo mesh fabric.

All dewatering will be tested for Pollutants per state guidelines weekly.

CONCRETE AND ASPHALT BATCH PLANT – not needed.

This shown for information only There are no existing batch plants located on this project site and there are no proposed batch plants in the future.

DRILLING SLURRY FOR DRILLING PIERS. – not needed.

This is shown for information only. No drilling slurry is allowed to be deposited onto the job site. All drilling slurry shall be collected and pumped into an on-site frac tank and shall be disposed of off-site.

There are no major potential pollutants anticipated to be used on the site.

ADDITIONAL (NONSTRUCTURAL) BEST MANAGEMENT PRACTICES FOR SEDIMENT:

1. Earth moving will be minimized by the engineering balancing of the site.
2. Disturbed portions of the site where construction activity temporarily ceases for at least 14 days will be stabilized with temporary seed and mulch no later than 14 days from the last construction activity in the area.
3. Seed bed preparation is not required if soil is in loose condition.
4. Prior to seeding, fertilizer shall be applied to each acre to be stabilized in accordance with the manufacturer's specifications.
5. If required seeding areas shall be mulched with straw to a uniformed cover. The straw mulch is to be tacked into place by a disk with blades set nearly straight.
6. A site-specific erosion control drawing has been developed showing the location of Best Management practices to be used during site construction.
7. Where indicated on the erosion control plan, Best Management Practices will be installed.
8. Material shall be in accordance with the plans and specifications and all construction shall be provided in accordance with the manufacturer's specifications.
9. All BMP's will be inspected bi-weekly and cleaned/maintained as required.

VI. AREAS AND VOLUMES

The site consists of 16.4 acres. 16.4 acres is expected to be disturbed for the proposed improvements

The unadjusted cut and fill quantities as of the writing of this report are listed below:

Cut Volume = xx Cubic Yards

please provide current best estimates

Fill Volume = xx Cubic Yards

Net Volume = xx Cubic Yards (Fill)

Note: The Total disturbed area shall be updated on the SWMP as changes occur.

VII. APPROPRIATE CONTROLS AND MEASURES

Also refer to attached Erosion and Sediment Control notes and plans included in the site plans.

MINIMIZE DISTURBED AREA AND PROTECT NATURAL FEATURES AND SOIL

All work will occur inside the limits of construction per the erosion Control Site Plan.

PHASE CONSTRUCTION ACTIVITY The sequence for the installation and removal of erosion and sediment control measures is as follows: Perimeter control measures (silt barriers and fencing) installed at designated areas as noted on the site plans (Exhibit 1), cleaning of street surfaces during construction if applicable, site grading, installation of utilities, paving final and grading, installation of sod or other vegetation, removal of temporary practices and perimeter controls, and site cleanup.

CONTROL STORMWATER FLOWING ONTO AND THROUGH THE PROJECT

Offsite stormwater flows on to this project site from two Unnamed Tributaries of the Falcon Basin West Tributary. The western reach was “relocated” under a separate permit. The two channel reaches combine on-site. On-site stormwater will be directed to water quality ponds that will function as sedimentation basins, so that no sediment enters the downstream receiving waters into the Falcon Basin West Tributary.

STABILIZE SOILS

No disturbed area, which are not actively being worked, shall remain denuded for more than 14 calendar days, unless otherwise authorized by the director. Temporary cover by seeding or mulching should be provided on areas which will be exposed for a period greater than 14 days before permanent stabilization can be achieved. Permanent cover should be provided on all areas as soon as possible, by means of seeding and mulching, straw or hay mulch is required. All soil stockpiles and borrow areas must protected with silt fence within 14 days after grading. All slopes within the project limits that are found to be eroding excessively within two years of permanent stabilization shall be provided additional slope stabilization methods such as seeding and mulching. Water is to be used for dust control. The Contractor will prevent the escape of this water and any sediment it may carry from the construction site.

PROTECT SLOPES

Temporary stabilization will include the installation of silt fences on level contours spaces at 10-20 foot intervals. Slopes will be seeded and covered with hay, straw or erosion control blankets on slopes greater than 3:1, as needed to provide for temporary stabilization until vegetation is permanently established. All slopes within the project limits that are found to be eroding excessively within two years of permanent stabilization shall be provided additional slope

stabilization methods such as seeding and mulching. Where slopes are steeper than 3:1 erosion control blankets (per specification requirements) will be utilized for final stabilization.

PROTECT STORM DRAIN INLETS

Inlet protection will be installed as soon as storm drain inlets are installed and before land disturbance activities begin in areas with existing storm drain systems. At the Contractor's discretion, additional temporary erosion control practices to include rock bags and sandbag barriers may be installed to prevent sediment movement. Inlet protection will include rock bags, erosion logs, and curb inlet sediment filters where an overflow capacity is necessary to prevent excessive ponding in front of the curb inlet. Concrete block and wire screen inlet protection detail, if used, will be added to Appendix prior to installation. This measure would be used where heavy flows are expected and where an overflow capacity is necessary to prevent excessive ponding around the inlet. Inlet protection devices will be inspected and accumulated sediment will be removed as needed.

ESTABLISH PERIMETER CONTROLS AND SEDIMENT BARRIERS

Temporary stabilization will include the installation of silt fences on the downslope perimeter of project area. The silt fence will be trenched in on the uphill side 6 inches deep and 6 inches wide, as detailed in the silt fence exhibit. Sediment will be removed when it reaches 1/3 the height of the fence. Silt fence will be inspected and replaced or repaired as needed.

RETAIN SEDIMENT ON-SITE

Temporary sediment traps shall be installed to detain sediment laden runoff from small watersheds for a period long enough to allow sediment to settle before discharge into receiving waters. For small drainage locations, smaller sediment traps should be used. At a minimum, silt fences, vegetative buffer strips or equivalent sediment controls are required for all down-slope boundaries (and for those side slope boundaries deemed appropriate as dictated by individual site conditions) of the construction. The use of a combination of sediment and erosion control measures in order to achieve maximum pollutant removal will be utilized. Sediment traps will be checked regularly for sediment cleanout. Sediments shall be removed and the trap restored to its original dimensions when the sediment has accumulated to one half the design volume of the wet storage. Sediment shall be disposed in suitable areas and in such a manner that will not erode or cause sedimentation problems. The gravel outlets will be checked regularly for sediment buildup which will prevent damage. If the gravel is clogged by sediment, it shall be removed and cleaned or replaced.

An alternate to sediment traps are temporary sediment basins.

ESTABLISH STABILIZED CONSTRUCTION EXITS

The construction entrance will be established in the entry points of roads. The construction entrance will be at least 50 feet in length and approximately 12 feet wide and graded so runoff does not leave the site. The aggregate will be established at 8 inches thick on top of 4 inch

minimum thick free draining material on top of geotextile and will consist of Type G dense graded material. A stabilized stone pad with a filter fabric under liner will be placed at points of vehicular ingress and egress.

ADDITIONAL BMP'S BMP SCHEDULE:

All Sediment and Erosion control BMP's (detailed below and only on BMP site map and details if utilized onsite) will be installed prior to any excavation or demolition and will be coordinated with the construction schedule. As construction changes and new temporary BMP's are needed to control sediment and erosion temporary BMP's will be installed within 24 hours of inspection report.

RECOMMENDED BMP'S: ALL RECOMMENDED BMP'S WILL BE INSTALLED PRIOR TO EXCAVATION NEAR ANY SENSITIVE AREAS.

Culvert Inlet Protection will be used to protect existing and new culvert inlets. Inlet Protection Detail will be included in Appendix before using onsite. Removal of this BMP will occur only after vegetation is established to a minimum of 70% pre construction coverage and after removal of BMP all sediment builds up will be removed and the area exposed shall be seeded.

Silt Fence is to be installed in sensitive areas to protect stream channels, pond, and overland runoff. On this site it will be used to protect runoff from the slip pits. See Silt Fence Detail. Removal of this BMP will occur only after vegetation is established to a minimum of 70% pre construction coverage and after removal of BMP all sediment builds up will be removed and the area exposed shall be seeded.

Vehicle Tracking Control is needed at the main construction entrance location. Vehicle tracking control shall be installed at the edge of the construction staging area where construction vehicles regularly exit onto existing asphalt road. If sediment tracking occurs it will be cleaned within 24 hours.

See Vehicle Tracking Control Detail in Construction Drawings. Removal of this BMP will occur only after project is substantially complete and is ready for seeding operations; the area will then be seeded per specification with the rest of the project.

Check Dams (rip rap) will be used to reduce storm water velocities in drainage channels during construction as a temporary measure until permanent stabilization can be created and vegetation has been established. Check Dam Detail will be included in the Appendix before using onsite. Removal of this BMP will occur only after vegetation is established to a minimum of 70% pre-construction coverage and after removal of BMP all sediment build-up will be removed and the area exposed shall be seeded.

Portable Toilets: Portable toilets are brought in from a service contractor and will be maintained in accordance with standard waste disposal practices using vacuum trucks and place on stable ground to minimize risk of spillage. All portable toilets will be kept a minimum of 500' from any waterway.

Waste Disposal: If needed Roll offs will be utilized for standard construction waste. A qualified contractor will remove waste weekly and take to an appropriate dump site off this project.

Portable toilets will be located a minimum of 10ft from stormwater inlets and 50ft from state waters. They will be secured at all four corners to prevent overturning and cleaned on a weekly basis. They will be inspected daily for spills.

PERMANENT BMP'S:

Re-vegetation: During construction any disturbed area not being currently worked left dormant longer than 14 days will be re-vegetated per specification with native seed and mulched and crimped with weed free straw.

All BMPs shall be installed and maintained in accordance with the most recent Urban Drainage and Flood Control District Urban Storm Drainage Criteria Manual.

VIII. MATERIALS HANDLING AND SPILL PREVENTION

MATERIAL HANDLING AND WASTE MANAGEMENT

The site will use a private refuse collector that will remove litter twice weekly. No less than one litter receptacle will be present at the construction site. In the event that unusual items such as tanks, cylinders, unidentified containers, etc. which could contain potentially hazardous materials are discovered or disturbed, the Fire and Rescue services will be notified. Litter and debris will be picked up and disposed of properly daily. Temporary toilet facilities will be located 500 feet away from any storm drain inlets and all waters of the state.

ESTABLISH PROPER BUILDING MATERIAL STAGING AREAS

A designated staging area will be used, location to be determined based on available space in the field and plans will be redline. The staging area will be contained per SWMP guidelines. All Equipment and Materials will be brought into the site as needed.

DESIGNATE WASHOUT AREAS

A concrete washout will be installed to detail as shown on the Construction Drawings and will be placed more than 500 feet away from any waters of the state.

ESTABLISH PROPER EQUIPMENT/VEHICLE FUELING AND MAINTENANCE PRACTICES

During construction the site will be exposed to operation and maintenance of construction equipment. The contractor shall be responsible for all activities such as fueling, oil changing, lubrication and repair which require use of petroleum products. Such products shall be transported to and from the site in special trucks equipped for that purpose. No waste petroleum products, rags, residue, or equipment parts shall be left on site. In the event of a spill or leak, causing soil to be contaminated, that soil shall be excavated placed in sealed barrels and removed from the site for transport to an approved location for disposal.

CONTROL EQUIPMENT/VEHICLE WASHING

This activity will not be allowed onsite.

ANY ADDITIONAL BMPs

Additional BMP's will be added to this SWMP as needed.

ALLOWABLE NON-STORMWATER DISCHARGE MANAGEMENT

There are no visible natural springs or irrigation, or other non-stormwater discharges anticipated to be encountered.

SELECTING POST-CONSTRUCTION BMPs

Post Construction BMPs. Re-vegetation including seeding, mulching and erosion control blanket will be final BMP's. Permanent stabilization will be achieved with 70% preconstruction vegetative establishment.

SPILL PREVENTION AND CONTROL PLAN

The SITE SUPERINTENDENT will act as the point of contact for any spill that occurs at this jobsite. The project manager will be responsible for implementation of prevention practices, spill containment / cleanup, worker training, reporting and complete documentation in the event of a spill. The ECO shall immediately notify the Owner, /Construction Manager, STATE and the Local Fire Department in addition to the legally required Federal, State, and Local reporting channels (including the National Response Center, 800.424.8802) if a reportable quantity is released to the environment.

SPILL PREVENTION BEST MANAGEMENT PRACTICES This section describes spill prevention methods Best Management Practices (BMP) that will be practiced to eliminate spills before they happen.

- **Equipment Staging and Maintenance:** Store and maintain equipment in a designated area Reduce the amount of hazardous materials and waste by substituting non-hazardous or less hazardous materials. Use secondary containment (drain pan) to catch spills when removing or changing fluids. Use proper equipment (pumps, funnels) to transfer fluids Keep spill kits readily accessible Check incoming vehicles for leaking oil and fluids. Transfer used fluids and oil filters to waste or recycling drums immediately following generation. Inspect equipment routinely for leaks and spills Repair equipment immediately, if necessary, implement a preventative maintenance schedule for equipment and vehicles.
- **Fueling Area:** Perform fueling in designated fueling area minimum 50' away from federal waters Use secondary containment (drain pan) to catch spills Use proper equipment (pumps, funnels) to transfer fluids Keep spill kits readily accessible Inspect fueling areas routinely for leaks and spills Hazardous Material Storage Areas Reduce the amount of hazardous materials by substituting non-hazardous or Less hazardous materials.
- **Hazardous Material Storage Areas:** Minimize the quantity of hazardous materials brought onsite Store hazardous materials in a designated area away from drainage points.
- **Unexpected Contaminated Soil and Water:** Perform all excavation activities carefully and only after the Owner/Construction Manager directed any activities.

SPILL CONTAINMENT METHODS

The following discussion identifies the types of secondary containment that will be used in the event of a spill. The Table below summarizes the containment methods for each potential source.

- **Equipment Staging and Maintenance Area:** An equipment leak from a fuel tank, equipment seal, or hydraulic line will be contained within a spill containment cell placed beneath all stationary potential leak sources. An undetected leak from parked equipment will be cleaned up using hand shovels and containerized in a 55-gallon steel drum for offsite disposal.
- **Fueling Area:** A small spill during fueling operations will be contained using fuel absorbent pads at the nozzle. The transfer of fuel into portable equipment will be performed using a funnel and/or hand pump and a spill pad used to absorb any incidental spills/drips. Any leaking tanks or drums will have fluids removed and transferred to another tank, drum, or container for the fluids. A spill response kit will be located near the fueling area or on the fuel truck for easy access. The spill response kit will include plastic sheeting, tarps, over pack drums, absorbent litter, and shovels.
- **Hazardous Material Storage Area:** A spill from containers or cans in a hazardous material storage area will be contained within the storage cabinet these materials are kept in.
- **Unexpected Contaminated Soil:** If contaminated soil is encountered during the project, the Owner/Construction Manager will be notified immediately. Small quantities of suspected contaminated soil will be placed on a 6-mil plastic liner and covered with 6-mil plastic. A soil berm or silt fence will be used to contain the stockpile and prevent migration of contaminated liquids in the soil.

Spill Prevention and Containment Methods Table

Potential Spill Source	Response Method
Equipment Staging and Maintenance Area	Spill containment pad, spill kit, pumps, funnels
Fueling Area (site equipment only)	Spill containment pad, spill kit, pumps, funnels
Hazardous Material Staging Area	Spill containment pad, spill kit, pumps, funnels
Unexpected Contaminated Soil	Plastic liner, plastic cover, soil berm, hay bales, lined super sacks

SPILL COUNTERMEASURES

Every preventative measure shall be taken to keep contaminated or hazardous materials contained. If a release occurs, the following actions shall be taken:

1. **Stop the Spill:** The severity of a spill at the site is anticipated to be minimal as large containers/quantities of Hazardous Materials (HM) are not anticipated. The type of spill would occur while dispensing material at the HM storage facility and would likely be contained in secondary containment. Thus, the use spill kits or other available absorbent materials should stop the spill.

2. Warn Others: Notify co-workers and supervisory personnel of the release. Notify emergency responders if appropriate. For site personnel, an alarm system will consist of three one second blasts on an air horn sounded by the person discovering a spill or fire. In the event of any spill, the Superintendent and Project Manager shall be notified if the spill is 5 gallons or more the STATE will be contacted along with the Fire Department.
3. Isolate the Area: Prevent public access to the area and continue to minimize the spread of the material. Minimize personal exposure throughout emergency response actions.
4. Containment: A spill shall only be contained by trained personnel and if it is safe to do so. DO NOT PLACE YOURSELF IN DANGER. Attempt to extinguish a fire only if it is in the incipient stage; trash can size or smaller. For larger spills, wait for the arrival of emergency response personnel and provide directions to the location of the emergency.
5. Complete a Spill and Incident Report: For each spill of a Hazardous Material a spill and incident report shall be completed and submitted to the Owner/Construction Manager and if applicable to the Engineer and the State of Colorado Department of Public Health and Environment

X. RECEIVING WATERS

The project site is located within the West Falcon Tributary. Stormwater from this site drains to an existing unnamed tributary to Black Squirrel Creek No. 2 that routes to a regional detention pond designated as Detention Pond WU South. Pond WU is a regional detention pond that approximately holds 50 ac-ft of volume. Pond WU outfalls back into the unnamed tributary to Black Squirrel Creek No. 2 that then continues to flow into Black Squirrel Creek.

Stream Crossing – No stream crossing is required for this development.

IX. INSPECTION AND RECORD KEEPING

The project is subject to inspections by the Colorado Division of Public Health and Environment (CDPHE), the Environmental Protection Agency (EPA), and El Paso County at any time.

Inspection of the stormwater management system shall be performed, by the SWMP Administrator, at least every 14 calendar days and after the occurrence of precipitation or snow melt event that may cause noticeable erosion or run-off. Time span greater than 14 calendar days is a violation of the CDPS permit.

SWMP ADMINISTRATOR

The individual(s), position, or title responsible for developing, implementing, maintaining, and revising the SWMP is to be determined upon award of the project. The individual(s) will be sufficiently qualified for the required duties per the *El Paso County ECM Appendix I.5*. The individual listed as the Erosion Control Supervisor shall fill out the information below and place in the on-site copy before beginning installation of the BMPs for this site and notify the County of the appropriate contact information.

SWMP Administrator Name:
Cell Phone:
Office Phone:
Email:

INSPECTION SCHEDULES

Inspections of the stormwater management system are required at least every 14 calendar days and within 24 hours after any precipitation or snowmelt event that causes surface runoff. A more frequent inspection schedule may be necessary to ensure that BMPs continue to operate as designed.

Differences or modifications in the field from the approved SWMP are required to be made within 72 hours site changes are observed. The SWMP shall be onsite at all times when onsite construction activity is occurring.

INSPECTION SCOPE

The construction site perimeter, all disturbed areas, material and/or waste storage areas that are exposed to precipitation, discharge locations, and locations where vehicles access the site shall be inspected for evidence of, or the potential for pollutants leaving the construction site boundaries or discharging to State Waters. All erosion and sediment control practices identified in the SWMP shall be evaluated to ensure that they are maintained and operating correctly.

INSPECTION REPORT

A thorough record of inspection shall be maintained and identify any incidents of non-compliance with the SWMP. Inspection records shall be retained for three years from expiration or inactivation of permit coverage. Federal, State, local authority reserves the right to request that a copy of the inspection reports be submitted. At a minimum, the inspection report shall include the following:

1. Inspection date
2. Name(s) and title(s) and signature(s) of personnel making the inspection
3. Location(s) of discharges of sediment or other pollutants from the site
4. Location(s) of BMPs that need to be maintained
5. Location(s) of BMPs that failed to operate as designed or proved inadequate for a particular location
6. Location(s) where additional BMPs are needed or were not in place at the time of inspection
7. Deviations from the minimum inspection schedule
8. Description of corrective action for items c, d, e and f above, dates corrective action(s) taken, and measures taken to prevent future violations, including requisite changes to the SWMP, as necessary
9. After adequate corrective action(s) have been taken, or where a report does not identify any incidents requiring corrective action, the report shall contain a signed statement

indicating the site is in compliance with the permit to the best of the signer's knowledge and belief

10. The date and amount of storm or snowmelt events that cause erosion.

BMP MAINTENANCE/REPLACEMENT AND FAILED BMPs

Adequate site assessment shall be performed as part of comprehensive Inspection and Maintenance procedures to assess the adequacy of BMPs at the site and to evaluate the necessity of changes to those BMPs to ensure continued effective performance. Where site assessment results in the determination that new or replacement BMPs are necessary, the BMPs shall be installed to ensure ongoing implementation. Failed BMPs must be addressed as soon as possible, in most cases immediately, to ensure continued performance and minimize the likelihood of pollutant discharge. The SWMP shall be updated once new BMPs are installed or failed BMPs replaced. A specific timeline for implementing maintenance procedures is not included in the State Permit because BMP maintenance is expected to be proactive, not responsive. Observations resulting in BMP maintenance activities can be made during a site inspection, or during general observations of site conditions. BMPs shall be maintained per DCM2 criteria and ECM criteria. Please refer to the Appendix for specific maintenance required for each BMP.

PLAN REVIEW AND REVISIONS

1. The plan must be signed in accordance with the general permit.
2. The plan must be made available, upon request, to CDPHE, United States Environmental Protection Agency, or operator of the local municipal storm sewer system, if applicable.
3. The plan must be amended whenever there is a change in design, construction, operation or maintenance that could have a significant effect on the potential for the discharge of pollutants to State Waters. It also must be amended if it is found to be ineffective in controlling pollutants present in stormwater.

RECORD KEEPING AND DOCUMENTING OF INSPECTION

The permittee shall retain a copy of the SWMP required by this permit (including a copy of the permit language) at the construction site (or other local location accessible to the Director; a State or local agency approving sediment and erosion plans, grading plans, or stormwater management plans; local government officials; or the operator of a municipal separate storm sewer receiving discharges from the site) from the date of project initiation to the date of final stabilization. Permittees with day-to-day operational control over SWMP implementation shall have a copy of the SWMP available at a central location on-site for the use of all operators and those identified as having responsibilities under the SWMP whenever they are on the construction site. If minor modifications to the SWMP are required, they shall be recorded on the owner's copy of the SWMP and be available during inspections. Whenever a significant change is made to the SWMP (including changes to design, construction, operation or maintenance), an

amended SWMP shall be submitted for review and approval. The following documents must be kept in a field office, trailer, shed or vehicle that is onsite during normal working hours:

1. A completed and signed copy of the Notice of Intent
2. The permit coverage letter from the Colorado Department of Public Health and Environment (CDPHE)
3. The Stormwater Management Plan
4. Site Inspection Records
5. A copy of the Colorado General Permit for Stormwater Discharges from Construction Activities

If a reasonable onsite location is not available, then the documents may be retained at a readily available alternative location, preferably with the SWMP plan contact. If the site is inactive, then the documents may be stored at a local office.

All records and information must be kept for at least three years or longer if requested by the Colorado Department of Public Health and Environment or United States Environmental Protection Agency.

RECORD KEEPING

The SWMP is a "living document" that is continuously reviewed and modified. The ECS shall make changes to the SWMP, including but not limited to: additions, deletions, changing locations of BMP's shall be marked in the plans, dated and initialed at time of occurrence.

All inspection and maintenance activities or other repairs will be documented by the ECS and the records kept on the project site.

Records of spill, leaks or overflows that result in the discharge of pollutants will be documented and maintained. The following Information will be recorded for all occurrences:

1. Time and date
2. Weather conditions
3. Reasons for spill
4. A release of any chemical, oil, petroleum product, sewage, etc., which may enter state waters must be reported.

At 14-day inspections incidents of noncompliance, such as uncontrolled releases of pollutants including mud, muddy water or measurable quantities of sediment found off-site shall be noted, along with a brief explanation as to measures taken to prevent future violations and measures taken to clean up sediment that has left the site.

After measures have been taken to correct any problems and recorded, or where a report does not identify incidents of noncompliance, the report shall contain a signed certification indicating the site is in compliance.

fix page #'s and adjust TOC accordingly.



Signature Page:

Engineer's Statement:

The Erosion and Stormwater Quality Control/Grading Plan was prepared under my direction and supervision and is correct to the best of my knowledge and belief. If such work is performed in accordance with the grading and erosion control plan, the work will not become a hazard to life and limb, endanger property, or adversely affect the safety, use, or stability of public way, drainage channel, or other property.

Grant Dennis Date
Registered Professional Engineer
State of Colorado No. 51622

Developer's Statement:

The owner will comply with the requirements of the Erosion and Stormwater Quality Control Plan including temporary BMP inspection requirements and final stabilization requirements. I acknowledge the responsibility to determine whether the construction activities on these plans require Colorado Discharge Permit System (CDPS) permitting for Stormwater discharges associated with Construction Activity.

Developer/ Owner Signature: _____

Name of Developer/ Owner: _____

DBA: _____ Phone: _____

Title: _____ Email: _____

Address: _____ Fax: _____

Developer/ Owner Signature: _____

Name of Developer/ Owner: _____

DBA: _____ Phone: _____

Title: _____ Email: _____

Address: _____ Fax: _____

APPENDIX A

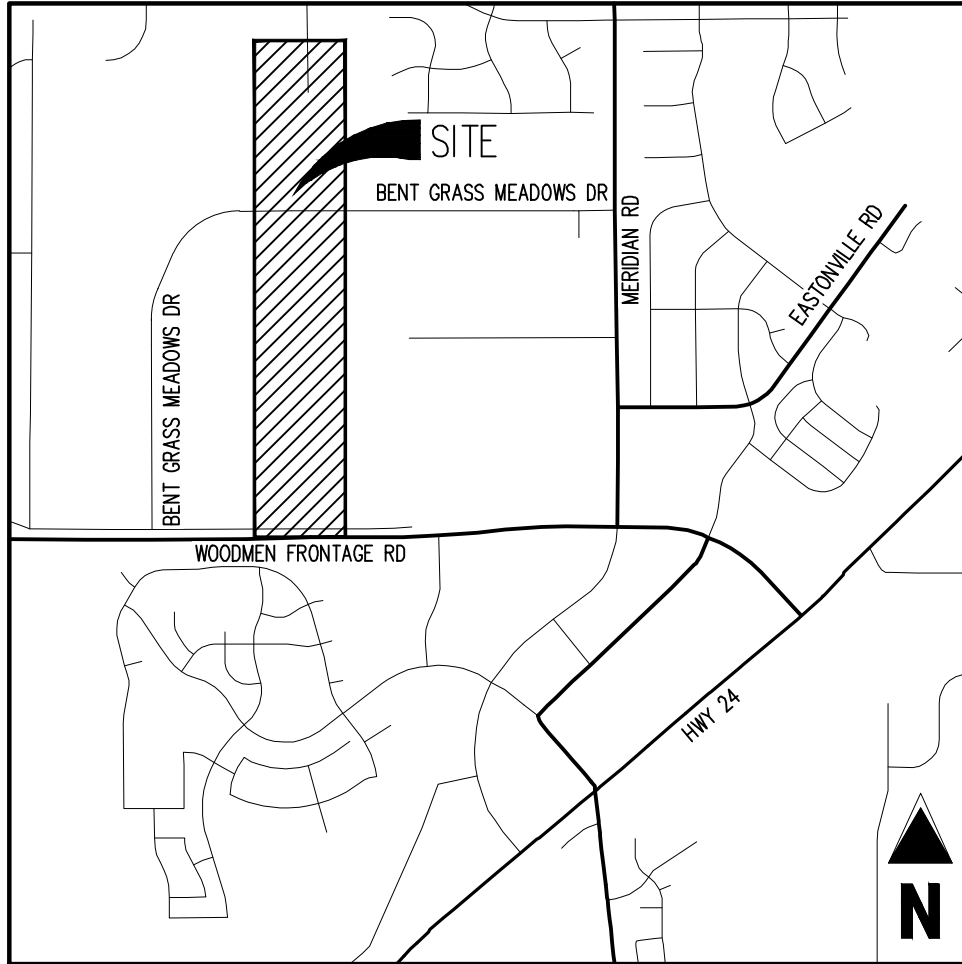

VICINITY MAP

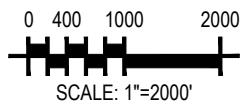

FALCON MEADOWS AT BENT GRASS
DRAINAGE CHANNEL IMPROVEMENTS

SCALE: 1"=1,000'
VICINITY MAP

Project No: CLH000023.20

Drawn By: TJE

Checked By: CMD

Date: 06/10/2021

Galloway

1155 Kelly Johnson Blvd., Suite 305
Colorado Springs, CO 80920
719.900.7220 • GallowayUS.com

APPENDIX B

Hydrologic Soil Group—El Paso County Area, Colorado

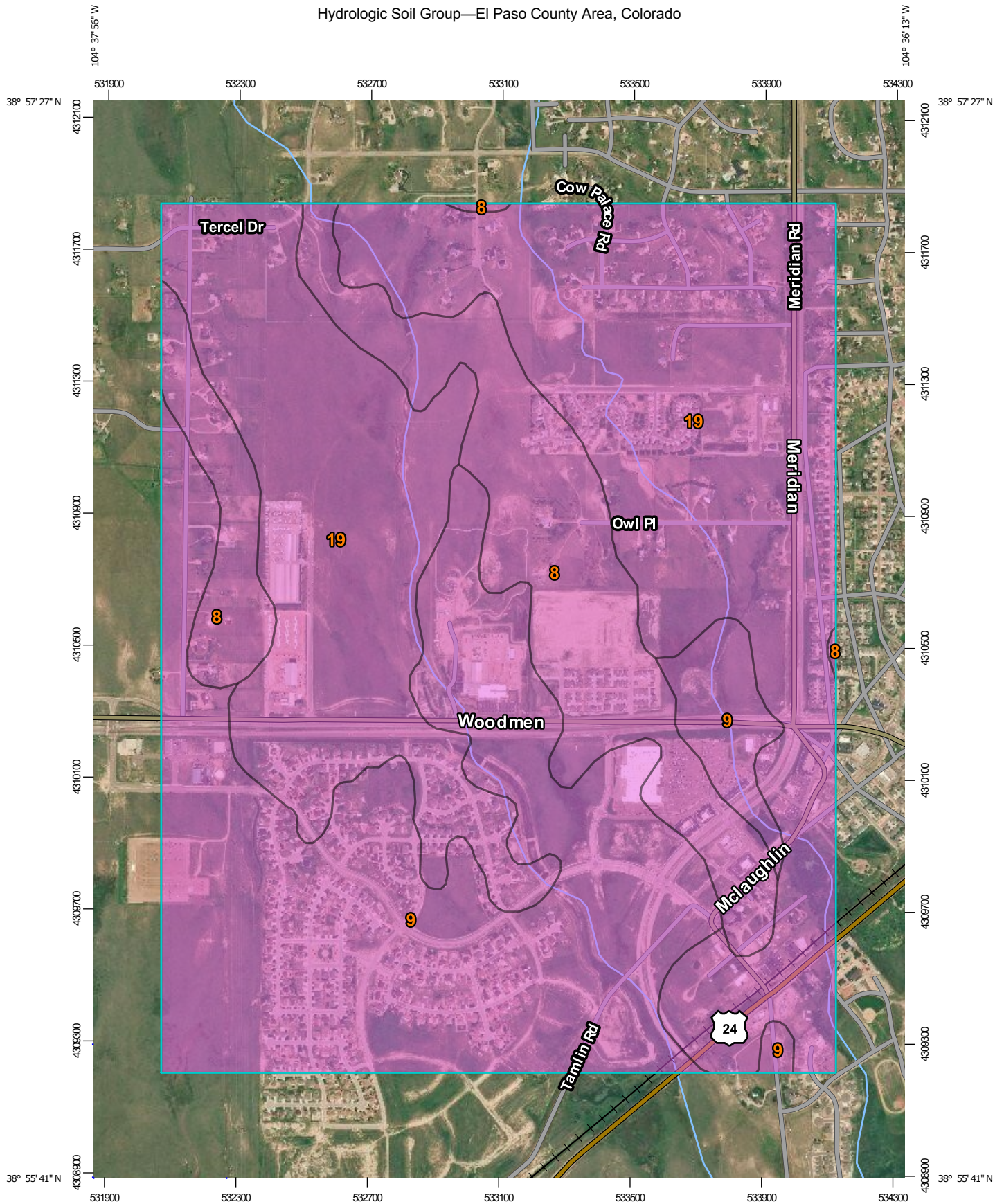

Map Scale: 1:15,900 if printed on A portrait (8.5" x 11") sheet.

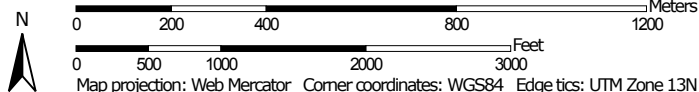

Map projection: Web Mercator Corner coordinates: WGS84 Edge tics: UTM Zone 13N WGS84



Natural Resources
Conservation Service

Web Soil Survey
National Cooperative Soil Survey

4/2/2019
Page 1 of 4

MAP LEGEND

Area of Interest (AOI)









 Area of Interest (AOI)

Soils

Soil Rating Polygons





-  A
-  A/D
-  B
-  B/D
-  C
-  C/D
-  D
-  Not rated or not available

Soil Rating Lines

-  A
-  A/D
-  B
-  B/D
-  C
-  C/D
-  D
-  Not rated or not available

Soil Rating Points





-  A
-  A/D
-  B
-  B/D

-  C
-  C/D
-  D
-  Not rated or not available

Water Features

 Streams and Canals

Transportation

-  Rails
-  Interstate Highways
-  US Routes
-  Major Roads
-  Local Roads

Background

 Aerial Photography

MAP INFORMATION

The soil surveys that comprise your AOI were mapped at 1:24,000.

Please rely on the bar scale on each map sheet for map measurements.

Source of Map: Natural Resources Conservation Service
 Web Soil Survey URL:
 Coordinate System: Web Mercator (EPSG:3857)

Maps from the Web Soil Survey are based on the Web Mercator projection, which preserves direction and shape but distorts distance and area. A projection that preserves area, such as the Albers equal-area conic projection, should be used if more accurate calculations of distance or area are required.

This product is generated from the USDA-NRCS certified data as of the version date(s) listed below.

Soil Survey Area: El Paso County Area, Colorado
 Survey Area Data: Version 16, Sep 10, 2018

Soil map units are labeled (as space allows) for map scales 1:50,000 or larger.

Date(s) aerial images were photographed: Jun 7, 2016—Aug 17, 2017

The orthophoto or other base map on which the soil lines were compiled and digitized probably differs from the background imagery displayed on these maps. As a result, some minor shifting of map unit boundaries may be evident.

Hydrologic Soil Group

Map unit symbol	Map unit name	Rating	Acres in AOI	Percent of AOI
8	Blakeland loamy sand, 1 to 9 percent slopes	A	214.3	16.0%
9	Blakeland-Fluvaquentic Haplaquolls	A	465.8	34.7%
19	Columbine gravelly sandy loam, 0 to 3 percent slopes	A	662.6	49.3%
Totals for Area of Interest			1,342.6	100.0%

Description

Hydrologic soil groups are based on estimates of runoff potential. Soils are assigned to one of four groups according to the rate of water infiltration when the soils are not protected by vegetation, are thoroughly wet, and receive precipitation from long-duration storms.

The soils in the United States are assigned to four groups (A, B, C, and D) and three dual classes (A/D, B/D, and C/D). The groups are defined as follows:

Group A. Soils having a high infiltration rate (low runoff potential) when thoroughly wet. These consist mainly of deep, well drained to excessively drained sands or gravelly sands. These soils have a high rate of water transmission.

Group B. Soils having a moderate infiltration rate when thoroughly wet. These consist chiefly of moderately deep or deep, moderately well drained or well drained soils that have moderately fine texture to moderately coarse texture. These soils have a moderate rate of water transmission.

Group C. Soils having a slow infiltration rate when thoroughly wet. These consist chiefly of soils having a layer that impedes the downward movement of water or soils of moderately fine texture or fine texture. These soils have a slow rate of water transmission.

Group D. Soils having a very slow infiltration rate (high runoff potential) when thoroughly wet. These consist chiefly of clays that have a high shrink-swell potential, soils that have a high water table, soils that have a claypan or clay layer at or near the surface, and soils that are shallow over nearly impervious material. These soils have a very slow rate of water transmission.

If a soil is assigned to a dual hydrologic group (A/D, B/D, or C/D), the first letter is for drained areas and the second is for undrained areas. Only the soils that in their natural condition are in group D are assigned to dual classes.

Rating Options

Aggregation Method: Dominant Condition

Component Percent Cutoff: None Specified

Tie-break Rule: Higher

APPENDIX C

NOTES TO USERS

This map is for use in administering the National Flood Insurance Program. It does not necessarily identify all areas subject to flooding, particularly from local drainage sources of small size. The community map repository should be consulted for possible updated or additional flood hazard information.

To obtain more detailed information in areas where **Base Flood Elevations (BFEs)** and/or **floodways** have been determined, users are encouraged to consult the Flood Profiles and Floodway Data and/or Summary of Stillwater Elevations tables contained within the Flood Insurance Study (FIS) report that accompanies this FIRM. Users should be aware that BFEs shown on the FIRM represent rounded whole-foot elevations. These BFEs are intended for flood insurance rating purposes only and should not be used as the sole source of flood elevation information. Accordingly, flood elevation data presented in the FIS report should be utilized in conjunction with the FIRM for purposes of construction and/or floodplain management.

Coastal Base Flood Elevations shown on this map apply only landward of 0.0' North American Vertical Datum of 1988 (NAVD88). Users of this FIRM should be aware that coastal flood elevations are also provided in the Summary of Stillwater Elevations table in the Flood Insurance Study report for this jurisdiction. Elevations shown in the Summary of Stillwater Elevations table should be used for construction and/or floodplain management purposes when they are higher than the elevations shown on this FIRM.

Boundaries of the **floodways** were computed at cross sections and interpolated between cross sections. The floodways were based on hydraulic considerations with regard to requirements of the National Flood Insurance Program. Floodway widths and other pertinent floodway data are provided in the Flood Insurance Study report for this jurisdiction.

Certain areas not in Special Flood Hazard Areas may be protected by **flood control structures**. Refer to section 2.4 "Flood Protection Measures" of the Flood Insurance Study report for information on flood control structures for this jurisdiction.

The **projection** used in the preparation of this map was Universal Transverse Mercator (UTM) zone 13. The **horizontal datum** was NAD83, GRS80 spheroid. Differences in datum, spheroid, projection or UTM zones used in the production of FIRMs for adjacent jurisdictions may result in slight positional differences in map features across jurisdiction boundaries. These differences do not affect the accuracy of this FIRM.

Flood elevations on this map are referenced to the **North American Vertical Datum of 1988 (NAVD88)**. These flood elevations must be compared to structure and ground elevations referenced to the same vertical datum. For information regarding conversion between the National Geodetic Vertical Datum of 1929 and the North American Vertical Datum of 1988, visit the National Geodetic Survey website at <http://www.ngs.noaa.gov/> or contact the National Geodetic Survey at the following address:

NGS Information Services
NOAA, NINGS12
National Geodetic Survey
SSMC-3, #9202
1315 East-West Highway
Silver Spring, MD 20910-3282

To obtain current elevation, description, and/or location information for **bench marks** shown on this map, please contact the Information Services Branch of the National Geodetic Survey at (301) 713-3242 or visit its website at <http://www.ngs.noaa.gov/>.

Base Map information shown on this FIRM was provided in digital format by El Paso County, Colorado Springs Utilities, City of Fountain, Bureau of Land Management, National Oceanic and Atmospheric Administration, United States Geological Survey, and Anderson Consulting Engineers, Inc. These data are current as of 2006.

This map reflects more detailed and up-to-date **stream channel configurations and floodplain delineations** than those shown on the previous FIRM for this jurisdiction. The floodplains and floodways that were transferred from the previous FIRM may have been adjusted to conform to these new stream channel configurations. As a result, the Flood Profiles and Floodway Data tables in the Flood Insurance Study Report (which contains authoritative hydraulic data) may reflect stream channel distances that differ from what is shown on this map. The profile baselines depicted on this map represent the hydraulic modeling baselines that match the flood profiles and Floodway Data Tables if applicable, in the FIS report. As a result, the profile baselines may deviate significantly from the new base map channel representation and may appear outside of the floodplain.

Corporate limits shown on this map are based on the best data available at the time of publication. Because changes due to annexations or de-annexations may have occurred after this map was published, map users should contact appropriate community officials to verify current corporate limit locations.

Please refer to the separately printed **Map Index** for an overview map of the county showing the layout of map panels; community map repository addresses; and a Listing of Communities table containing National Flood Insurance Program dates for each community as well as a listing of the panels on which each community is located.

Contact **FEMA Map Service Center (MSC)** via the FEMA Map Information eXchange (FMIX) 1-877-336-2627 for information on available products associated with this FIRM. Available products may include previously issued Letters of Map Change, a Flood Insurance Study Report, and/or digital versions of this map. The MSC may also be reached by Fax at 1-800-358-9820 and its website at <http://www.msc.fema.gov/>.

If you have **questions about this map** or **questions concerning the National Flood Insurance Program** in general, please call **1-877-FEMA MAP (1-877-336-2627)** or visit the FEMA website at <http://www.fema.gov/business/nfp>.

El Paso County Vertical Datum Offset Table	
Flooding Source	Vertical Datum Offset (ft)
REFER TO SECTION 3.3 OF THE EL PASO COUNTY FLOOD INSURANCE STUDY FOR STREAM BY STREAM VERTICAL DATUM CONVERSION INFORMATION	

Panel Location Map

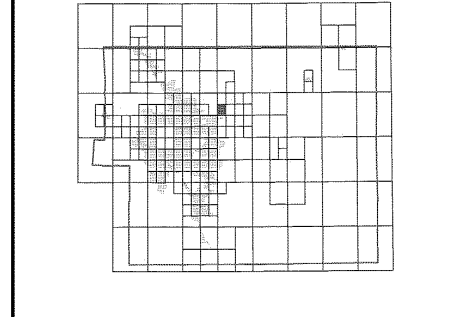

This Digital Flood Insurance Rate Map (DFIRM) was produced through a Cooperating Technical Partner (CTP) agreement between the State of Colorado Water Conservation Board (CWCB) and the Federal Emergency Management Agency (FEMA).

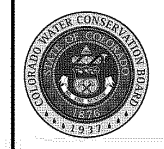

Additional Flood Hazard information and resources are available from local communities and the Colorado Water Conservation Board.

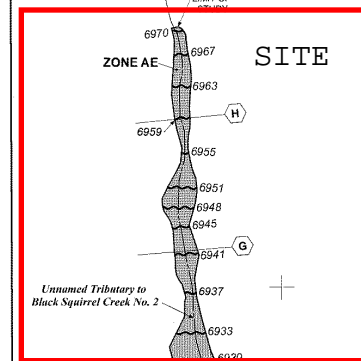
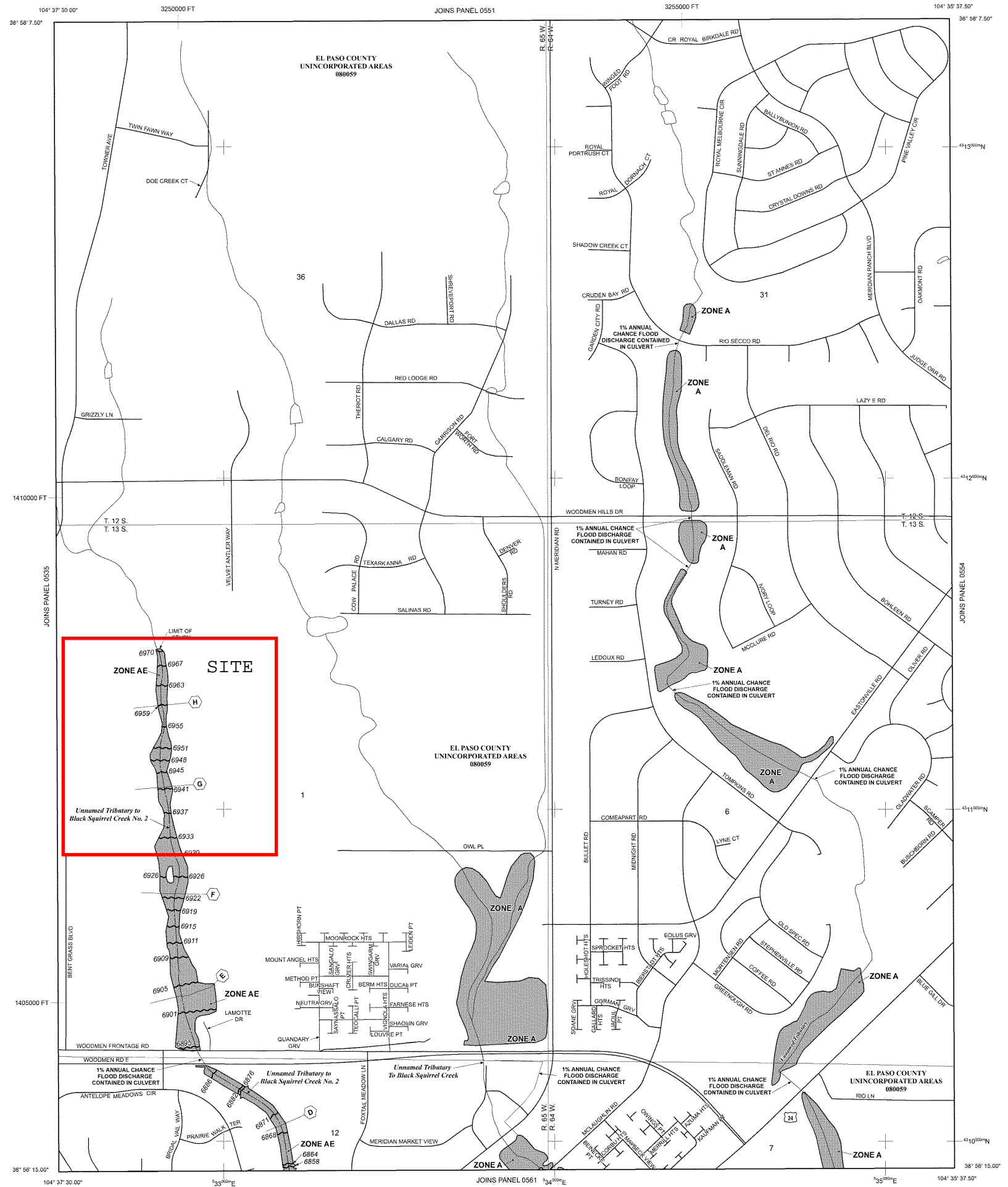

LEGEND

- SPECIAL FLOOD HAZARD AREAS (SFHAS) SUBJECT TO INUNDATION BY THE 1% ANNUAL CHANCE FLOOD**
 - ZONE A** No Base Flood Elevations determined.
 - ZONE AE** Base Flood Elevations determined.
 - ZONE AH** Flood depths of 1 to 3 feet (usually areas of ponding); Base Flood Elevations determined.
 - ZONE AO** Flood depths of 1 to 3 feet (usually sheet flow on sloping terrain); average depths determined. For areas of alluvial fan flooding, velocities also determined.
 - ZONE AR** Special Flood Hazard Area Formerly protected from the 1% annual chance flood by a flood control system that was subsequently decertified. Zone AR indicates that the former flood control system is being restored to provide protection from the 1% annual chance or greater flood.
 - ZONE A99** Area to be protected from 1% annual chance flood by a Federal flood protection system under construction; no Base Flood Elevations determined.
 - ZONE V** Coastal flood zone with velocity hazard (wave action); no Base Flood Elevations determined.
 - ZONE VE** Coastal flood zone with velocity hazard (wave action); Base Flood Elevations determined.
- FLOODWAY AREAS IN ZONE AE**
 - The floodway is the channel of a stream plus any adjacent floodplain areas that must be kept free of encroachment so that the 1% annual chance flood can be carried without substantial increases in flood heights.
- OTHER FLOOD AREAS**
 - ZONE X** Areas of 0.2% annual chance flood; areas of 1% annual chance flood with average depths of less than 1 foot or with drainage areas less than 1 square mile; and areas protected by levees from 1% annual chance flood.
- OTHER AREAS**
 - ZONE X** Areas determined to be outside the 0.2% annual chance floodplain.
 - ZONE D** Areas in which flood hazards are undetermined, but possible.
- COASTAL BARRIER RESOURCES SYSTEM (CBRS) AREAS**
- OTHERWISE PROTECTED AREAS (OPAs)**
 - CBRS areas and OPAs are normally located within or adjacent to Special Flood Hazard Areas.
- Boundaries**
 - Floodplain boundary
 - Floodway boundary
 - Zone D Boundary
 - CBRS and OPA boundary
- Boundary dividing Special Flood Hazard Areas of different Base Flood Elevations, flood depths or flood velocities**
- Base Flood Elevation line and value; elevation in feet* (EL 987)**
- Base Flood Elevation value where uniform within zone; elevation in feet***
- * Referenced to the North American Vertical Datum of 1988 (NAVD 88)**
- Cross section line**
- Transect line**
- Geographic coordinates referenced to the North American Datum of 1983 (NAD 83)**
- 1000-meter Universal Transverse Mercator grid ticks, zone 13**
- 5000-foot grid ticks: Colorado State Plane coordinate system, central zone (FIPSZONE 0502), Lambert Conformal Conic Projection**
- Bench mark (see explanation in Notes to Users section of this FIRM panel)**
- River Mile**
- MAP REPOSITORIES**
 - Refer to Map Repositories list on Map Index
- EFFECTIVE DATE OF COUNTYWIDE FLOOD INSURANCE RATE MAP**
MARCH 17, 1997
- EFFECTIVE DATE(S) OF REVISION(S) TO THIS PANEL**
DECEMBER 7, 2018 - to update corporate limits, to change Base Flood Elevations and Special Flood Hazard Areas, to update map format, to add roads and road names, and to incorporate previously issued Letters of Map Revision.
- For community map revision history prior to countywide mapping, refer to the Community Map History Table located in the Flood Insurance Study report for this jurisdiction.
- To determine if flood insurance is available in this community, contact your insurance agent or call the National Flood Insurance Program at 1-800-638-6620.

MAP SCALE 1" = 500'

NFP

PANEL 0553G

FIRM

FLOOD INSURANCE RATE MAP

EL PASO COUNTY, COLORADO AND INCORPORATED AREAS

PANEL 553 OF 1300

(SEE MAP INDEX FOR FIRM PANEL LAYOUT)

CONTAINS:

COMMUNITY	NUMBER	PANEL	SUFFIX
EL PASO COUNTY	08059	553	G

Noted to User: The Map Number shown below should be used when placing map orders. The Community Number shown above should be used on insurance applications for the subject community.

MAP NUMBER 08041C0553G

MAP REVISED DECEMBER 7, 2018

Federal Emergency Management Agency

APPENDIX D

#	Date	Issue / Description	Init.

Project No:	CLH000021
Drawn By:	CMWJ
Checked By:	RGD
Date:	05/XX/2021

OVERALL GRADING PLAN

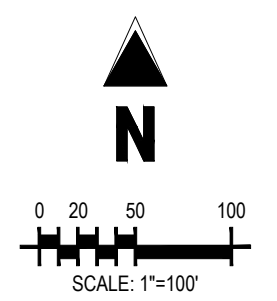
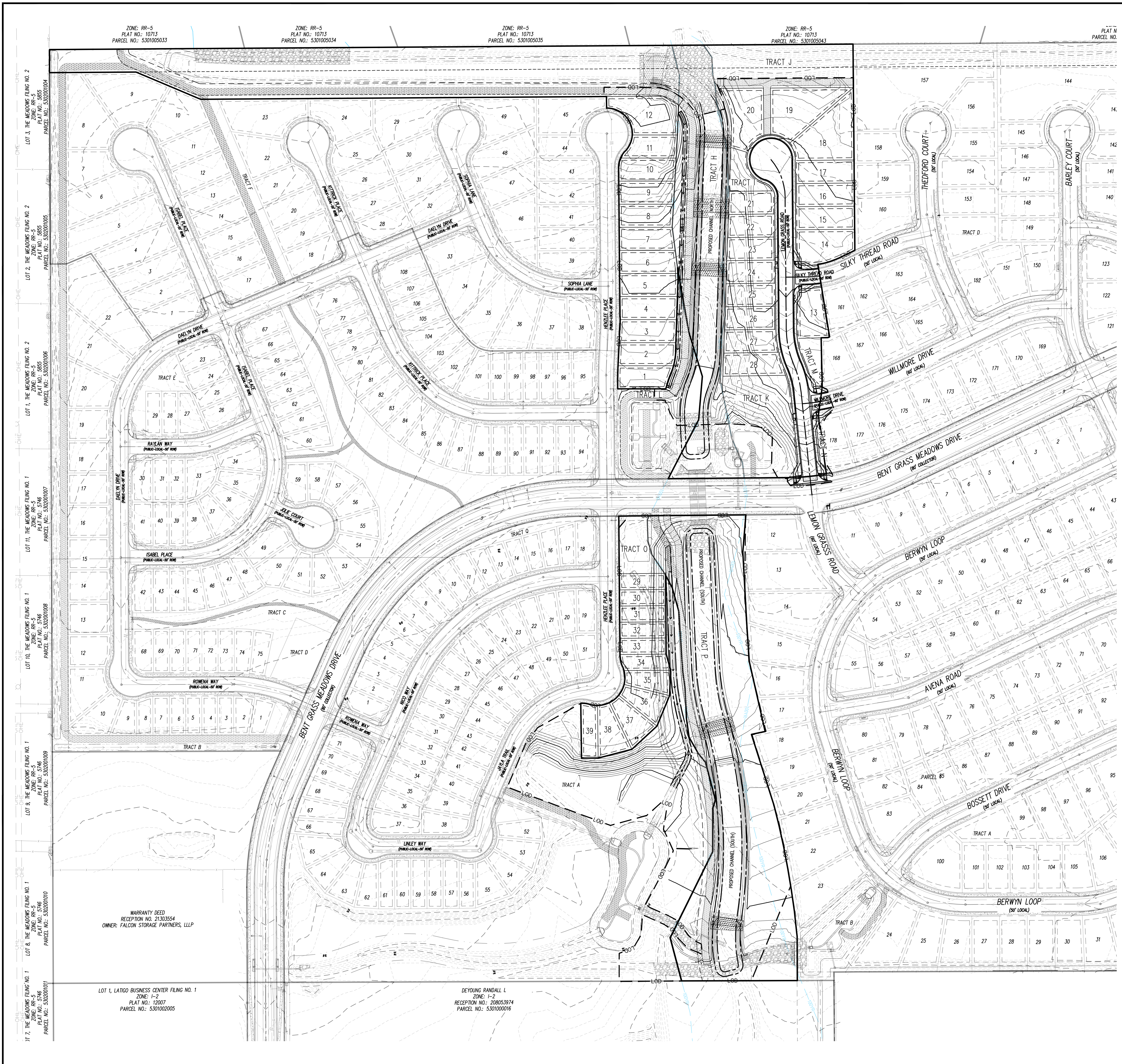

- ### LEGEND
- EXISTING PROPERTY LINE
 - PROPOSED PROJECT BOUNDARY
 - PROPOSED RIGHT OF WAY LINE
 - - - EXISTING LOT LINE
 - - - PROPOSED LOT LINE
 - - - EXISTING EASEMENT
 - - - PROPOSED EASEMENT
 - - - EXISTING SUBDIVISION BUFFER
 - - - EXISTING MAJOR CONTOUR (e.g., 6940)
 - - - EXISTING MINOR CONTOUR (e.g., 6940)
 - - - PROPOSED MAJOR CONTOUR (e.g., 6939)
 - - - PROPOSED MINOR CONTOUR (e.g., 6939)
 - - - EXISTING STORM DRAIN PIPE
 - - - PROPOSED STORM DRAIN PIPE
 - - - EXISTING WATER LINE
 - - - PROPOSED WATER LINE
 - - - EXISTING SANITARY SEWER LINE
 - - - PROPOSED SANITARY SEWER LINE
 - - - EXISTING DRAINAGE FEATURE OUTLINE
 - - - PROPOSED DRAINAGE FEATURE OUTLINE
 - - - EXISTING SWALE WITH FLOW DIRECTION
 - - - PROPOSED SWALE WITH FLOW DIRECTION
 - - - 100-YEAR FEMA FLOODPLAIN
 - - - CUT / FILL
 - - - 100-YEAR FLOODPLAIN 50-FT BUFFER
 - - - PROPOSED 1" TO 2" CRUSHED ROCK
 - - - PROPOSED RIP RAP
 - - - EXISTING CONCRETE PAVING
 - - - EXISTING CDOT CLASS 6 GRAVEL
 - - - EXISTING 1" TO 2" CRUSHED ROCK
 - - - EXISTING RIP RAP
 - - - EXISTING GROUTED BOULDERS
 - - - PROPOSED LOT #
 - - - EXISTING LOT # (BENT GRASS FILING NO. 2)
 - - - PROPOSED ADA RAMP
 - 55.00 HP SPOT ELEVATION - HIGH POINT
 - 55.00 LP SPOT ELEVATION - LOW POINT
 - 55.00 FG SPOT ELEVATION - FINISH GRADE
 - 2.00% EXISTING SLOPE (PERCENT)
 - 4:1 EXISTING SLOPE (RISE:RUN)
 - 2.00% PROPOSED SLOPE (PERCENT)
 - 4:1 PROPOSED SLOPE (RISE:RUN)
 - FLOW ARROW

- ### NOTES
- ADD 6900 TO ALL SPOT ELEVATIONS
 - THE PLAN SHALL NOT SUBSTANTIALLY CHANGE THE DEPTH OF COVER, OR ACCESS TO UTILITY FACILITIES. ADDITIONALLY, THE PLAN SHALL NOT INCREASE OR DIVERT WATER TOWARDS UTILITY FACILITIES. ANY CHANGES TO UTILITY FACILITIES TO ACCOMMODATE THE PLAN, MUST BE DISCUSSED AND AGREED TO BY THE AFFECTED UTILITY PRIOR TO IMPLEMENTING THE PLAN. THE RESULTING COST TO RELOCATE OR PROJECT UTILITIES, OR PROVIDE INTERIM ACCESS IS AT THE EXPENSE OF THE PLAN APPLICANT.

EROSION CONTROL PHASING SCHEDULE	
PHASE	DESCRIPTION
INITIAL	INSTALL SILT FENCE, ALL INLET PROTECTION MEASURES ON EXISTING INLETS, AND CURB SOCKS ALONG BENT GRASS MEADOWS DRIVE
INTERIM	CONVERT EXISTING SEDIMENT BASIN FROM "EARLY GRADING & EROSION CONTROL PLANS" TO THE PROPOSED WATER QUALITY CAPTURE VOLUME DETENTION BASIN W/ ALL PERMANENT CONTROL MEASURES. THEN, INSTALL STABILIZED STAGING AREA, VEHICLE TRACKING CONTROL, AT ENTRANCES, AND CONCRETE WASHOUT AREA, THEN OVERLOT GRADE THE ENTIRE PROJECT SITE AS SHOWN ON PLAN VIEW, INSTALL STRIP BALE BARRIERS ALONG INTERNAL ROADWAYS, AND INSTALL CHECK DAMS ALONG PROPOSED SWALES. FINALLY, INSTALL PROPOSED STORM SEWER. CONTRACTOR TO USE EXTREME CAUTION TO NOT DAMAGE THE WATER AND WASTEWATER IMPROVEMENTS COMPLETED IN THE EARLY METRO DISTRICT IMPROVEMENTS PLAN SET.
FINAL	CONSTRUCT CURB/GUTTER AND PAVEMENT. CONSTRUCT GAS/ELECTRIC/CABLE/PHONE IN ROW AREAS. REMOVE CONSTRUCTION BMP'S ONCE VERTICAL CONSTRUCTION OF HOUSES AND APPLICABLE LANDSCAPING IS COMPLETE.

BASIS OF BEARINGS
ALL BEARINGS ARE GRID BEARINGS OF THE COLORADO STATE PLANE COORDINATE SYSTEM, CENTRAL ZONE, NORTH AMERICAN DATUM 1983. THE BEARING OF THE LINE BETWEEN THE SOUTHWEST CORNER OF SECTION 1, T13S, R65W AND THE WEST QUARTER CORNER SECTION 1, T13S, R65W IS N007.3487W AND MONUMENTED AS SHOWN.

BENCHMARK
THE SOUTHWEST CORNER OF LOT 1 WOODMEN HILLS FILING NO. 4, MONUMENTED BY A YELLOW PLASTIC SURVEYORS CAP ON A NO. 4 REBAR 1.5" X 2.0" ELEVATION = 6947.67

CAUTION - NOTICE TO CONTRACTOR

- ALL UTILITY LOCATIONS SHOWN ARE BASED ON MAPS PROVIDED BY THE APPROPRIATE UTILITY COMPANY AND FIELD SURFACE EVIDENCE AT THE TIME OF SURVEY AND IS TO BE CONSIDERED AN APPROXIMATE LOCATION ONLY. IT IS THE CONTRACTOR'S RESPONSIBILITY TO FIELD VERIFY THE FIELD LOCATION OF ALL UTILITIES, PUBLIC OR PRIVATE, WHETHER SHOWN ON THE PLANS OR NOT, PRIOR TO CONSTRUCTION. REPORT ANY DISCREPANCIES TO THE ENGINEER PRIOR TO CONSTRUCTION.
- WHERE A PROPOSED UTILITY CROSSES AN EXISTING UTILITY, IT IS THE CONTRACTOR'S RESPONSIBILITY TO FIELD VERIFY THE HORIZONTAL AND VERTICAL LOCATION OF SUCH EXISTING UTILITY, EITHER THROUGH POT-HOLING OR ALTERNATIVE METHOD. REPORT INFORMATION TO THE ENGINEER PRIOR TO CONSTRUCTION.



ZONE: RR-5 PLAT NO.: 10713 PARCEL NO.: 5301005033

ZONE: RR-5 PLAT NO.: 10713 PARCEL NO.: 5301005034

ZONE: RR-5 PLAT NO.: 10713 PARCEL NO.: 5301005035

ZONE: RR-5 PLAT NO.: 10713 PARCEL NO.: 5301005043

PLAT # PARCEL NO.

WARRANTY DEED
RECEPTION NO. 21303554
OWNER: FALCON STORAGE PARTNERS, LLLP

LOT 1, LATIGO BUSINESS CENTER FILING NO. 1
ZONE: I-2
PLAT NO.: 12007
PARCEL NO.: 5301002005

DEYOING RANDALL L
ZONE: I-2
RECEPTION NO.: 208053974
PARCEL NO.: 5301000016

LOT 1, THE MEADOWS FILING NO. 2
ZONE: RR-5
PARCEL NO.: 5302001004

LOT 2, THE MEADOWS FILING NO. 2
ZONE: RR-5
PARCEL NO.: 5302001005

LOT 3, THE MEADOWS FILING NO. 2
ZONE: RR-5
PARCEL NO.: 5302001006

LOT 4, THE MEADOWS FILING NO. 2
ZONE: RR-5
PARCEL NO.: 5302001007

LOT 5, THE MEADOWS FILING NO. 2
ZONE: RR-5
PARCEL NO.: 5302001008

LOT 6, THE MEADOWS FILING NO. 2
ZONE: RR-5
PARCEL NO.: 5302001009

LOT 7, THE MEADOWS FILING NO. 2
ZONE: RR-5
PARCEL NO.: 5302001010

LOT 8, THE MEADOWS FILING NO. 1
ZONE: RR-5
PARCEL NO.: 5302001011

LOT 9, THE MEADOWS FILING NO. 1
ZONE: RR-5
PARCEL NO.: 5302001012

LOT 10, THE MEADOWS FILING NO. 1
ZONE: RR-5
PARCEL NO.: 5302001013

LOT 11, THE MEADOWS FILING NO. 1
ZONE: RR-5
PARCEL NO.: 5302001014

LOT 12, THE MEADOWS FILING NO. 1
ZONE: RR-5
PARCEL NO.: 5302001015

LOT 13, THE MEADOWS FILING NO. 1
ZONE: RR-5
PARCEL NO.: 5302001016

LOT 14, THE MEADOWS FILING NO. 1
ZONE: RR-5
PARCEL NO.: 5302001017

LOT 15, THE MEADOWS FILING NO. 1
ZONE: RR-5
PARCEL NO.: 5302001018

LOT 16, THE MEADOWS FILING NO. 1
ZONE: RR-5
PARCEL NO.: 5302001019

LOT 17, THE MEADOWS FILING NO. 1
ZONE: RR-5
PARCEL NO.: 5302001020

LOT 18, THE MEADOWS FILING NO. 1
ZONE: RR-5
PARCEL NO.: 5302001021

LOT 19, THE MEADOWS FILING NO. 1
ZONE: RR-5
PARCEL NO.: 5302001022

LOT 20, THE MEADOWS FILING NO. 1
ZONE: RR-5
PARCEL NO.: 5302001023

LOT 21, THE MEADOWS FILING NO. 1
ZONE: RR-5
PARCEL NO.: 5302001024

LOT 22, THE MEADOWS FILING NO. 1
ZONE: RR-5
PARCEL NO.: 5302001025

LOT 23, THE MEADOWS FILING NO. 1
ZONE: RR-5
PARCEL NO.: 5302001026

LOT 24, THE MEADOWS FILING NO. 1
ZONE: RR-5
PARCEL NO.: 5302001027

LOT 25, THE MEADOWS FILING NO. 1
ZONE: RR-5
PARCEL NO.: 5302001028

LOT 26, THE MEADOWS FILING NO. 1
ZONE: RR-5
PARCEL NO.: 5302001029

LOT 27, THE MEADOWS FILING NO. 1
ZONE: RR-5
PARCEL NO.: 5302001030

LOT 28, THE MEADOWS FILING NO. 1
ZONE: RR-5
PARCEL NO.: 5302001031

LOT 29, THE MEADOWS FILING NO. 1
ZONE: RR-5
PARCEL NO.: 5302001032

LOT 30, THE MEADOWS FILING NO. 1
ZONE: RR-5
PARCEL NO.: 5302001033

LOT 31, THE MEADOWS FILING NO. 1
ZONE: RR-5
PARCEL NO.: 5302001034

LOT 32, THE MEADOWS FILING NO. 1
ZONE: RR-5
PARCEL NO.: 5302001035

LOT 33, THE MEADOWS FILING NO. 1
ZONE: RR-5
PARCEL NO.: 5302001036

LOT 34, THE MEADOWS FILING NO. 1
ZONE: RR-5
PARCEL NO.: 5302001037

LOT 35, THE MEADOWS FILING NO. 1
ZONE: RR-5
PARCEL NO.: 5302001038

LOT 36, THE MEADOWS FILING NO. 1
ZONE: RR-5
PARCEL NO.: 5302001039

LOT 37, THE MEADOWS FILING NO. 1
ZONE: RR-5
PARCEL NO.: 5302001040

LOT 38, THE MEADOWS FILING NO. 1
ZONE: RR-5
PARCEL NO.: 5302001041

LOT 39, THE MEADOWS FILING NO. 1
ZONE: RR-5
PARCEL NO.: 5302001042

LOT 40, THE MEADOWS FILING NO. 1
ZONE: RR-5
PARCEL NO.: 5302001043

LOT 41, THE MEADOWS FILING NO. 1
ZONE: RR-5
PARCEL NO.: 5302001044

LOT 42, THE MEADOWS FILING NO. 1
ZONE: RR-5
PARCEL NO.: 5302001045

LOT 43, THE MEADOWS FILING NO. 1
ZONE: RR-5
PARCEL NO.: 5302001046

LOT 44, THE MEADOWS FILING NO. 1
ZONE: RR-5
PARCEL NO.: 5302001047

LOT 45, THE MEADOWS FILING NO. 1
ZONE: RR-5
PARCEL NO.: 5302001048

LOT 46, THE MEADOWS FILING NO. 1
ZONE: RR-5
PARCEL NO.: 5302001049

LOT 47, THE MEADOWS FILING NO. 1
ZONE: RR-5
PARCEL NO.: 5302001050

LOT 48, THE MEADOWS FILING NO. 1
ZONE: RR-5
PARCEL NO.: 5302001051

LOT 49, THE MEADOWS FILING NO. 1
ZONE: RR-5
PARCEL NO.: 5302001052

LOT 50, THE MEADOWS FILING NO. 1
ZONE: RR-5
PARCEL NO.: 5302001053

LOT 51, THE MEADOWS FILING NO. 1
ZONE: RR-5
PARCEL NO.: 5302001054

LOT 52, THE MEADOWS FILING NO. 1
ZONE: RR-5
PARCEL NO.: 5302001055

LOT 53, THE MEADOWS FILING NO. 1
ZONE: RR-5
PARCEL NO.: 5302001056

LOT 54, THE MEADOWS FILING NO. 1
ZONE: RR-5
PARCEL NO.: 5302001057

LOT 55, THE MEADOWS FILING NO. 1
ZONE: RR-5
PARCEL NO.: 5302001058

LOT 56, THE MEADOWS FILING NO. 1
ZONE: RR-5
PARCEL NO.: 5302001059

LOT 57, THE MEADOWS FILING NO. 1
ZONE: RR-5
PARCEL NO.: 5302001060

LOT 58, THE MEADOWS FILING NO. 1
ZONE: RR-5
PARCEL NO.: 5302001061

LOT 59, THE MEADOWS FILING NO. 1
ZONE: RR-5
PARCEL NO.: 5302001062

LOT 60, THE MEADOWS FILING NO. 1
ZONE: RR-5
PARCEL NO.: 5302001063

LOT 61, THE MEADOWS FILING NO. 1
ZONE: RR-5
PARCEL NO.: 5302001064

LOT 62, THE MEADOWS FILING NO. 1
ZONE: RR-5
PARCEL NO.: 5302001065

LOT 63, THE MEADOWS FILING NO. 1
ZONE: RR-5
PARCEL NO.: 5302001066

LOT 64, THE MEADOWS FILING NO. 1
ZONE: RR-5
PARCEL NO.: 5302001067

LOT 65, THE MEADOWS FILING NO. 1
ZONE: RR-5
PARCEL NO.: 5302001068

LOT 66, THE MEADOWS FILING NO. 1
ZONE: RR-5
PARCEL NO.: 5302001069

LOT 67, THE MEADOWS FILING NO. 1
ZONE: RR-5
PARCEL NO.: 5302001070

LOT 68, THE MEADOWS FILING NO. 1
ZONE: RR-5
PARCEL NO.: 5302001071

LOT 69, THE MEADOWS FILING NO. 1
ZONE: RR-5
PARCEL NO.: 5302001072

LOT 70, THE MEADOWS FILING NO. 1
ZONE: RR-5
PARCEL NO.: 5302001073

LOT 71, THE MEADOWS FILING NO. 1
ZONE: RR-5
PARCEL NO.: 5302001074

LOT 72, THE MEADOWS FILING NO. 1
ZONE: RR-5
PARCEL NO.: 5302001075

LOT 73, THE MEADOWS FILING NO. 1
ZONE: RR-5
PARCEL NO.: 5302001076

LOT 74, THE MEADOWS FILING NO. 1
ZONE: RR-5
PARCEL NO.: 5302001077

LOT 75, THE MEADOWS FILING NO. 1
ZONE: RR-5
PARCEL NO.: 5302001078

LOT 76, THE MEADOWS FILING NO. 1
ZONE: RR-5
PARCEL NO.: 5302001079

LOT 77, THE MEADOWS FILING NO. 1
ZONE: RR-5
PARCEL NO.: 5302001080

LOT 78, THE MEADOWS FILING NO. 1
ZONE: RR-5
PARCEL NO.: 5302001081

LOT 79, THE MEADOWS FILING NO. 1
ZONE: RR-5
PARCEL NO.: 5302001082

LOT 80, THE MEADOWS FILING NO. 1
ZONE: RR-5
PARCEL NO.: 5302001083

LOT 81, THE MEADOWS FILING NO. 1
ZONE: RR-5
PARCEL NO.: 5302001084

LOT 82, THE MEADOWS FILING NO. 1
ZONE: RR-5
PARCEL NO.: 5302001085

LOT 83, THE MEADOWS FILING NO. 1
ZONE: RR-5
PARCEL NO.: 5302001086

LOT 84, THE MEADOWS FILING NO. 1
ZONE: RR-5
PARCEL NO.: 5302001087

LOT 85, THE MEADOWS FILING NO. 1
ZONE: RR-5
PARCEL NO.: 5302001088

LOT 86, THE MEADOWS FILING NO. 1
ZONE: RR-5
PARCEL NO.: 5302001089

LOT 87, THE MEADOWS FILING NO. 1
ZONE: RR-5
PARCEL NO.: 5302001090

LOT 88, THE MEADOWS FILING NO. 1
ZONE: RR-5
PARCEL NO.: 5302001091

LOT 89, THE MEADOWS FILING NO. 1
ZONE: RR-5
PARCEL NO.: 5302001092

LOT 90, THE MEADOWS FILING NO. 1
ZONE: RR-5
PARCEL NO.: 5302001093

LOT 91, THE MEADOWS FILING NO. 1
ZONE: RR-5
PARCEL NO.: 5302001094

LOT 92, THE MEADOWS FILING NO. 1
ZONE: RR-5
PARCEL NO.: 5302001095

LOT 93, THE MEADOWS FILING NO. 1
ZONE: RR-5
PARCEL NO.: 5302001096

LOT 94, THE MEADOWS FILING NO. 1
ZONE: RR-5
PARCEL NO.: 5302001097

LOT 95, THE MEADOWS FILING NO. 1
ZONE: RR-5
PARCEL NO.: 5302001098

LOT 96, THE MEADOWS FILING NO. 1
ZONE: RR-5
PARCEL NO.: 5302001099

LOT 97, THE MEADOWS FILING NO. 1
ZONE: RR-5
PARCEL NO.: 5302001100

LOT 98, THE MEADOWS FILING NO. 1
ZONE: RR-5
PARCEL NO.: 5302001101

LOT 99, THE MEADOWS FILING NO. 1
ZONE: RR-5
PARCEL NO.: 5302001102

LOT 100, THE MEADOWS FILING NO. 1
ZONE: RR-5
PARCEL NO.: 5302001103

LOT 101, THE MEADOWS FILING NO. 1
ZONE: RR-5
PARCEL NO.: 5302001104

LOT 102, THE MEADOWS FILING NO. 1
ZONE: RR-5
PARCEL NO.: 5302001105

LOT 103, THE MEADOWS FILING NO. 1
ZONE: RR-5
PARCEL NO.: 5302001106

LOT 104, THE MEADOWS FILING NO. 1
ZONE: RR-5
PARCEL NO.: 5302001107

LOT 105, THE MEADOWS FILING NO. 1
ZONE: RR-5
PARCEL NO.: 5302001108

LOT 106, THE MEADOWS FILING NO. 1
ZONE: RR-5
PARCEL NO.: 5302001109

LOT 107, THE MEADOWS FILING NO. 1
ZONE: RR-5
PARCEL NO.: 5302001110

LOT 108, THE MEADOWS FILING NO. 1
ZONE: RR-5
PARCEL NO.: 5302001111

LOT 109, THE MEADOWS FILING NO. 1
ZONE: RR-5
PARCEL NO.: 5302001112

LOT 110, THE MEADOWS FILING NO. 1
ZONE: RR-5
PARCEL NO.: 5302001113

LOT 111, THE MEADOWS FILING NO. 1
ZONE: RR-5
PARCEL NO.: 5302001114

LOT 112, THE MEADOWS FILING NO. 1
ZONE: RR-5
PARCEL NO.: 5302001115

LOT 113, THE MEADOWS FILING NO. 1
ZONE: RR-5
PARCEL NO.: 5302001116

LOT 114, THE MEADOWS FILING NO. 1
ZONE: RR-5
PARCEL NO.: 5302001117

LOT 115, THE MEADOWS FILING NO. 1
ZONE: RR-5
PARCEL NO.: 5302001118

LOT 116, THE MEADOWS FILING NO. 1
ZONE: RR-5
PARCEL NO.: 5302001119

LOT 117, THE MEADOWS FILING NO. 1
ZONE: RR-5
PARCEL NO.: 5302001120

LOT 118, THE MEADOWS FILING NO. 1
ZONE: RR-5
PARCEL NO.: 5302001121

LOT 119, THE MEADOWS FILING NO. 1
ZONE: RR-5
PARCEL NO.: 5302001122

LOT 120, THE MEADOWS FILING NO. 1
ZONE: RR-5
PARCEL NO.: 5302001123

LOT 121, THE MEADOWS FILING NO. 1
ZONE: RR-5
PARCEL NO.: 5302001124

LOT 122, THE MEADOWS FILING NO. 1
ZONE: RR-5
PARCEL NO.: 5302001125

LOT 123, THE MEADOWS FILING NO. 1
ZONE: RR-5
PARCEL NO.: 5302001126

LOT 124, THE MEADOWS FILING NO. 1
ZONE: RR-5
PARCEL NO.: 5302001127

LOT 125, THE MEADOWS FILING NO. 1
ZONE: RR-5
PARCEL NO.: 5302001128

LOT 126, THE MEADOWS FILING NO. 1
ZONE: RR-5
PARCEL NO.: 5302001129

LOT 127, THE MEADOWS FILING NO. 1
ZONE: RR-5
PARCEL NO.: 5302001130

LOT 128, THE MEADOWS FILING NO. 1
ZONE: RR-5
PARCEL NO.: 5302001131

LOT 129, THE MEADOWS FILING NO. 1
ZONE: RR-5
PARCEL NO.: 5302001132

LOT 130, THE MEADOWS FILING NO. 1
ZONE: RR-5
PARCEL NO.: 5302001133

LOT 131, THE MEADOWS FILING NO. 1
ZONE: RR-5
PARCEL NO.: 5302001134

LOT 132, THE MEADOWS FILING NO. 1
ZONE: RR-5
PARCEL NO.: 5302001135

LOT 133, THE MEADOWS FILING NO. 1
ZONE: RR-5
PARCEL NO.: 5302001136

LOT 134, THE MEADOWS FILING NO. 1
ZONE: RR-5
PARCEL NO.: 5302001137

LOT 135, THE MEADOWS FILING NO. 1
ZONE: RR-5
PARCEL NO.: 5302001138

LOT 136, THE MEADOWS FILING NO. 1
ZONE: RR-5
PARCEL NO.: 5302001139

LOT 137, THE MEADOWS FILING NO. 1
ZONE: RR-5
PARCEL NO.: 5302001140

LOT 138, THE MEADOWS FILING NO. 1
ZONE: RR-5
PARCEL NO.: 5302001141

LOT 139, THE MEADOWS FILING NO. 1
ZONE: RR-5
PARCEL NO.: 5302001142

LOT 140, THE MEADOWS FILING NO. 1
ZONE: RR-5
PARCEL NO.: 5302001143

LOT 141, THE MEADOWS FILING NO. 1
ZONE: RR-5
PARCEL NO.: 5302001144

LOT 142, THE MEADOWS FILING NO. 1
ZONE: RR-5
PARCEL NO.: 5302001145

LOT 143, THE MEADOWS FILING NO. 1
ZONE: RR-5
PARCEL NO.: 5302001146

LOT 144, THE MEADOWS FILING NO. 1
ZONE: RR-5
PARCEL NO.: 5302001147

LOT 145, THE MEADOWS FILING NO. 1
ZONE: RR-5
PARCEL NO.: 5302001148

LOT 146, THE MEADOWS FILING NO. 1
ZONE: RR-5
PARCEL NO.: 5302001149

LOT 147, THE MEADOWS FILING NO. 1
ZONE: RR-5
PARCEL NO.: 5302001150

LOT 148, THE MEADOWS FILING NO. 1
ZONE: RR-5
PARCEL NO.: 5302001151

LOT 149, THE MEADOWS FILING NO. 1
ZONE: RR-5
PARCEL NO.: 5302001152

LOT 150, THE MEADOWS FILING NO. 1
ZONE: RR-5
PARCEL NO.: 5302001153

LOT 151, THE MEADOWS FILING NO. 1
ZONE: RR-5
PARCEL NO.: 5302001154

LOT 152, THE MEADOWS FILING NO. 1
ZONE: RR-5
PARCEL NO.: 5302001155

LOT 153, THE MEADOWS FILING NO. 1
ZONE: RR-5
PARCEL NO.: 5302001156

LOT 154, THE MEADOWS FILING NO. 1
ZONE: RR-5
PARCEL NO.: 5302001157

LOT 155, THE MEADOWS FILING NO. 1
ZONE: RR-5
PARCEL NO.: 5302001158

LOT 156, THE MEADOWS FILING NO. 1
ZONE: RR-5
PARCEL NO.: 5302001159

LOT 157, THE MEADOWS FILING NO. 1
ZONE: RR-5
PARCEL NO.: 5302001160

LOT 158, THE MEADOWS FILING NO. 1
ZONE: RR-5
PARCEL NO.: 5302001161

LOT 159, THE MEADOWS FILING NO. 1
ZONE: RR-5
PARCEL NO.: 5302001162

LOT 160, THE MEADOWS FILING NO. 1
ZONE: RR-5
PARCEL NO.: 5302001163

LOT 161, THE MEADOWS FILING NO. 1
ZONE: RR-5
PARCEL NO.: 5302001164

LOT 162, THE MEADOWS FILING NO. 1
ZONE: RR-5
PARCEL NO.: 5302001165

LOT 163, THE MEADOWS FILING NO. 1
ZONE: RR-5
PARCEL NO.: 5302001166

LOT 164, THE MEADOWS FILING NO. 1
ZONE: RR-5
PARCEL NO.: 5302001167

LOT 165, THE MEADOWS FILING NO. 1
ZONE: RR-5
PARCEL NO.: 5302001168

LOT 166, THE MEADOWS FILING NO. 1
ZONE: RR-5
PARCEL NO.: 5302001169

LOT 167, THE MEADOWS FILING NO. 1
ZONE: RR-5
PARCEL NO.: 5302001170

LOT 168, THE MEADOWS FILING NO. 1
ZONE: RR-5
PARCEL NO.: 5302001171

LOT 169, THE MEADOWS FILING NO. 1
ZONE: RR-5
PARCEL NO.: 5302001172

LOT 170, THE MEADOWS FILING NO. 1
ZONE: RR-5
PARCEL NO.: 5302001173

LOT 171, THE MEADOWS FILING NO. 1
ZONE: RR-5
PARCEL NO.: 5302001174

LOT 172, THE MEADOWS FILING NO. 1
ZONE: RR-5
PARCEL NO.: 5302001175

LOT 173, THE MEADOWS FILING NO. 1
ZONE: RR-5
PARCEL NO.: 5302001176

LOT 174, THE MEADOWS FILING NO. 1
ZONE: RR-5
PARCEL NO.: 5302001177

LOT 175, THE MEADOWS FILING NO. 1
ZONE: RR-5
PARCEL NO.: 5302001178

LOT 176, THE MEADOWS FILING NO. 1
ZONE: RR-5
PARCEL NO.: 5302001179

LOT 177, THE MEADOWS FILING NO. 1
ZONE: RR-5
PARCEL NO.: 5302001180

LOT 178, THE MEADOWS FILING NO. 1
ZONE: RR-5
PARCEL NO.: 5302001181

LOT 179, THE MEADOWS FILING NO. 1
ZONE: RR-5
PARCEL NO.: 5302001182

LOT 180, THE MEADOWS FILING NO. 1
ZONE: RR-5
PARCEL NO.: 5302001183

LOT 181, THE MEADOWS FILING NO. 1
ZONE: RR-5
PARCEL NO.: 5302001184

LOT 182, THE MEADOWS FILING NO. 1
ZONE: RR-5
PARCEL NO.: 5302001185

LOT 183, THE MEADOWS FILING NO. 1
ZONE: RR-5
PARCEL NO.: 5302001186

LOT 184, THE MEADOWS FILING NO. 1
ZONE: RR-5
PARCEL NO.: 5302001187

LOT 185, THE MEADOWS FILING NO. 1
ZONE: RR-5
PARCEL NO.: 5302001188

LOT 186, THE MEADOWS FILING NO. 1
ZONE: RR-5
PARCEL NO.: 5302001189

LOT 187, THE MEADOWS FILING NO. 1
ZONE: RR-5
PARCEL NO.: 5302001190

LOT 188, THE MEADOWS FILING NO. 1
ZONE: RR-5
PARCEL NO.: 5302001191

LOT 189, THE MEADOWS FILING NO. 1
ZONE: RR-5
PARCEL NO.: 5302001192

LOT 190, THE MEADOWS FILING NO. 1
ZONE: RR-5
PARCEL NO.: 5302001193

LOT 191, THE MEADOWS FILING NO. 1
ZONE: RR-5
PARCEL NO.: 5302001194

LOT 192, THE MEADOWS FILING NO. 1
ZONE: RR-5
PARCEL NO.: 5302

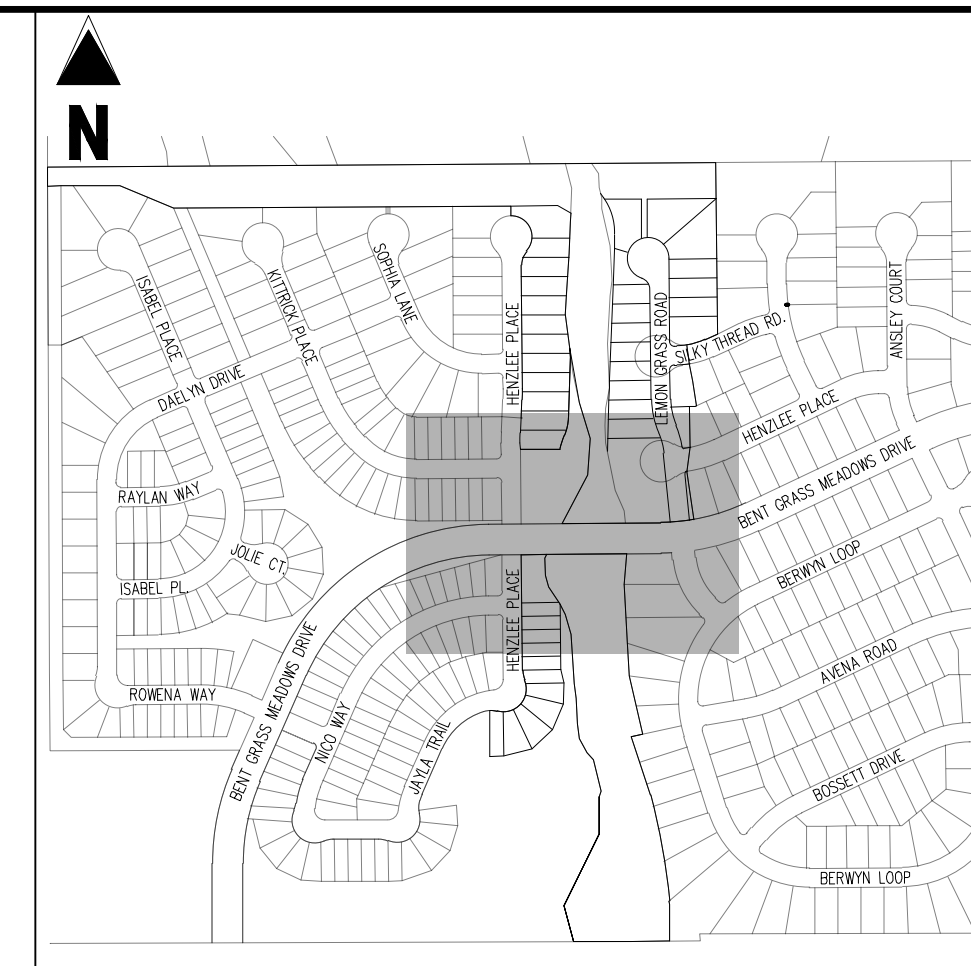

KEY MAP
 SCALE: 1"=500'

COPYRIGHT
 THESE PLANS ARE AN INSTRUMENT OF SERVICE AND ARE THE PROPERTY OF GALLOWAY, AND MAY NOT BE DUPLICATED, DISCLOSED, OR REPRODUCED WITHOUT THE WRITTEN CONSENT OF GALLOWAY. COPYRIGHTS AND INFRINGEMENTS WILL BE ENFORCED AND PROSECUTED.

CHALLENGER HOMES

CONSTRUCTION DOCUMENTS
 FALCON MEADOWS AT BENT GRASS FILING NO. 4
 FOR
 CHALLENGER COMMUNITIES, LLC

BENT GRASS MEADOWS DRIVE & MERIDIAN ROAD
 FALCON, CO 80831 - EL PASO COUNTY

#	Date	Issue / Description	Init.

Project No: CLH000021
 Drawn By: CMWJ
 Checked By: RGD
 Date: 05/01/2021

GRADING & EROSION CONTROL INITIAL PLAN

G1.2
 Sheet 6 of 25

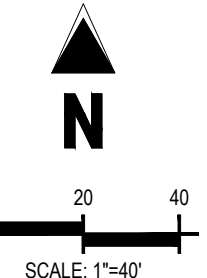
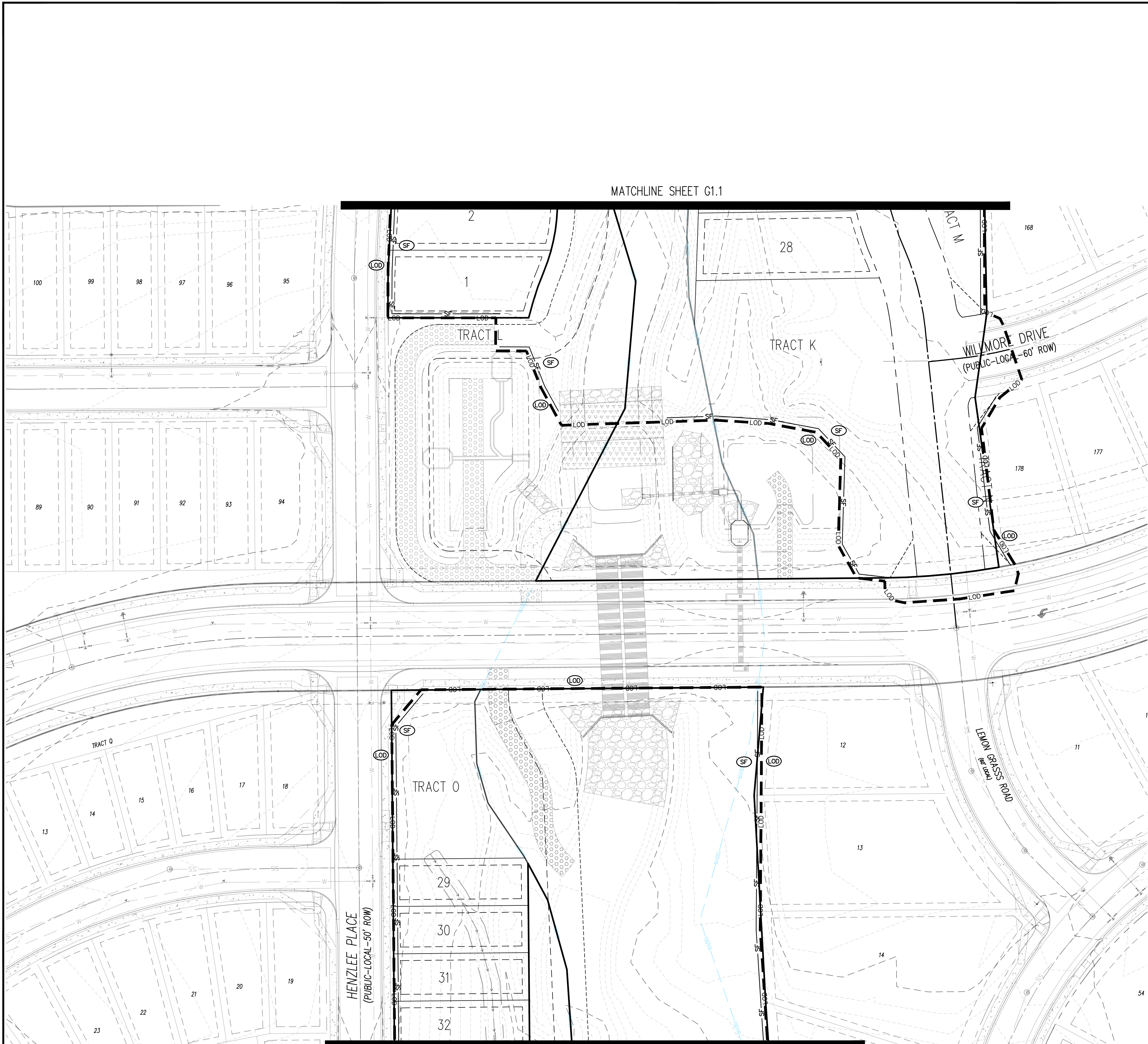

EROSION CONTROL LEGEND

- LOD (LOD) LIMITS OF DISTURBANCE / CONSTRUCTION
- SF (SF) SILT FENCE
- CF (CF) CONSTRUCTION FENCE
- (IPS) SUMP INLET PROTECTION
- (IPO) ON-GRADE INLET PROTECTION
- (RS) ROCK SOCKS
- (VTC) VEHICLE TRACKING CONTROL
- (CWA) CONCRETE WASHOUT AREA
- (SSA) STABILIZED STAGING AREA
- (SC) PROPOSED SAWCUT LINE
- (PT) PORTABLE TOILET
- (SP) STOCKPILE
- (CD) CHECK DAM
- (RR) RIPRAP OUTFALL PADS
- (SITE) SITE (CONTACTS AND PERMITS)
- (WP) WASHOUT POSTING
- (SBB) STRAW BALE BARRIER
- (SB) SEDIMENT BASIN

NOTES

- ADD 8900 TO ALL SPOT ELEVATIONS
- THE PLAN SHALL NOT SUBSTANTIALLY CHANGE THE DEPTH OF COVER, OR ACCESS TO UTILITY FACILITIES. ADDITIONALLY, THE PLAN SHALL NOT INCREASE OR DIVERT WATER TOWARDS UTILITY FACILITIES. ANY CHANGES TO UTILITY FACILITIES TO ACCOMMODATE THE PLAN, MUST BE DISCUSSED AND AGREED TO BY THE AFFECTED UTILITY PRIOR TO IMPLEMENTING THE PLAN. THE RESULTING COST TO RELOCATE PROTECT UTILITIES, OR PROVIDE INTERIM ACCESS IS AT THE EXPENSE OF THE PLAN APPLICANT.
- NO UTILITIES ARE TO BE PERMANENTLY DISTURBED FOR THIS PLAN.
- NO GRADING IS TO OCCUR WITHIN THE 100-YEAR FLOODPLAIN.
- THE EROSION CONTROL DELINEATED ON THIS PLAN SHALL BE REGULARLY UPDATED BY THE CONTRACTORS.
- CONTRACTOR SHALL PROTECT ALL AREAS OUTSIDE OF THE CONSTRUCTION LIMITS WITH SILT FENCE OR OTHER METHOD TO PROTECT UNDISTURBED AREAS FROM EROSION.
- ALL TEMPORARY OR PERMANENT GRADING DISTURBANCES SHALL BE RE-SEEDDED AND MULCHED PER EL PASO COUNTY CRITERIA AND SPECIFICATIONS.
- ALL TEMPORARY RIPRAP SHOWN ON THE PLANS SHALL BE TYPE "M". RIPRAP SHALL BE PLACED IN THE LOCATIONS INDICATED BY THE PLAN OR IN AREAS AS THE CONTRACTOR SEES FIT TO CONTROL EROSION. ALL RIPRAP SHALL BE PLACED AT A MINIMUM THICKNESS OF 1.5' DEEP.
- ALL TEMPORARY STORM DRAIN SHOWN ON THE PLANS SHALL BE 24" DIA. HP POLYPROPYLENE. ALL PIPE SHALL BE LAD TO ACHIEVE A MIN. SLOPE OF 0.5%.

EROSION CONTROL PHASING SCHEDULE

PHASE	DESCRIPTION
INITIAL	INSTALL SILT FENCE, ALL INLET PROTECTION MEASURES ON EXISTING INLETS, AND CURB SOCKS ALONG BENT GRASS MEADOWS DRIVE
INTERM	CONVERT EXISTING SEDIMENT BASIN FROM "EARLY GRADING & EROSION CONTROL PLANS" TO THE PROPOSED WATER QUALITY CAPTURE VOLUME DETENTION BASIN W/ ALL PERMANENT CONTROL MEASURES. THEN, INSTALL STABILIZED STAGING AREA, VEHICLE TRACKING CONTROL AT ENTRANCES, AND CONCRETE WASHOUT AREA. THEN OVERLOT GRADE THE ENTIRE PROJECT SITE AS SHOWN ON PLAN VIEW. INSTALL STRAW BALE BARRIERS ALONG INTERNAL ROADWAYS, AND INSTALL CHECK DAMS ALONG PROPOSED SWALES. FINALLY, INSTALL PROPOSED STORM SEWER. CONTRACTOR TO USE EXTREME CAUTION TO NOT DAMAGE THE WATER AND WASTEWATER IMPROVEMENTS COMPLETED IN THE EARLY METRO DISTRICT IMPROVEMENTS PLAN SET.
FINAL	CONSTRUCT CURB/GUTTER AND PAVEMENT. CONSTRUCT GAS/ELECTRIC/CABLE/PHONE IN ROW AREAS. REMOVE CONSTRUCTION BMP'S ONCE VERTICAL CONSTRUCTION OF HOUSES AND APPLICABLE LANDSCAPING IS COMPLETE.

LEGEND

- EXISTING PROPERTY LINE
- PROPOSED PROJECT BOUNDARY
- PROPOSED RIGHT OF WAY LINE
- EXISTING LOT LINE
- PROPOSED LOT LINE
- EXISTING EASEMENT
- PROPOSED EASEMENT
- EXISTING SUBDIVISION BUFFER
- EXISTING MAJOR CONTOUR
- EXISTING MINOR CONTOUR
- PROPOSED MAJOR CONTOUR
- PROPOSED MINOR CONTOUR
- EXISTING STORM DRAIN PIPE
- PROPOSED STORM DRAIN PIPE
- EXISTING WATER LINE
- PROPOSED WATER LINE
- EXISTING SANITARY SEWER LINE
- PROPOSED SANITARY SEWER LINE
- EXISTING DRAINAGE FEATURE OUTLINE
- PROPOSED DRAINAGE FEATURE OUTLINE
- EXISTING SWALE WITH FLOW DIRECTION
- PROPOSED SWALE WITH FLOW DIRECTION
- 100-YEAR FEMA FLOODPLAIN
- CUT / FILL
- 100-YEAR FLOODPLAIN 50-FT BUFFER
- PROPOSED 1" TO 2" CRUSHED ROCK
- PROPOSED RIP RAP
- EXISTING CONCRETE PAVING
- EXISTING CDOT CLASS 6 GRAVEL
- EXISTING 1" TO 2" CRUSHED ROCK
- EXISTING RIP RAP
- EXISTING GROUDED BOULDERS
- PROPOSED LOT #
- EXISTING LOT # (BENT GRASS FILING NO. 2)
- PROPOSED ADA RAMP
- SPOT ELEVATION - HIGH POINT
- SPOT ELEVATION - LOW POINT
- SPOT ELEVATION - FINISH GRADE
- EXISTING SLOPE (PERCENT)
- EXISTING SLOPE (RISE:RUN)
- PROPOSED SLOPE (PERCENT)
- PROPOSED SLOPE (RISE:RUN)
- FLOW ARROW

BASIS OF BEARINGS

ALL BEARINGS ARE GRID BEARINGS OF THE COLORADO STATE PLANE COORDINATE SYSTEM, CENTRAL ZONE, NORTH AMERICAN DATUM 1983. THE BEARING OF THE LINE BETWEEN THE SOUTHWEST CORNER OF SECTION 1, T13S, R65W AND THE WEST QUARTER CORNER SECTION 1, T13S, R65W IS N001°3'46"W AND MONUMENTED AS SHOWN.

BENCHMARK

THE SOUTHWESTERLY CORNER OF LOT 1 WOODMEN HILLS FILING NO. 4, MONUMENTED BY A YELLOW PLASTIC SURVEYORS CAP ON A NO. 4 REBAR L# 24954 ELEVATION = 6947.67

CAUTION - NOTICE TO CONTRACTOR

- ALL UTILITY LOCATIONS SHOWN ARE BASED ON MAPS PROVIDED BY THE APPROPRIATE UTILITY COMPANY AND FIELD SURFACE EVIDENCE AT THE TIME OF SURVEY AND IS TO BE CONSIDERED AN APPROXIMATE LOCATION ONLY. IT IS THE CONTRACTOR'S RESPONSIBILITY TO FIELD VERIFY THE FIELD LOCATION OF ALL UTILITIES, PUBLIC OR PRIVATE, WHETHER SHOWN ON THE PLANS OR NOT, PRIOR TO CONSTRUCTION. REPORT ANY DISCREPANCIES TO THE ENGINEER PRIOR TO CONSTRUCTION.
- WHERE A PROPOSED UTILITY CROSSES AN EXISTING UTILITY, IT IS THE CONTRACTOR'S RESPONSIBILITY TO FIELD VERIFY THE HORIZONTAL AND VERTICAL LOCATION OF SUCH EXISTING UTILITY, EITHER THROUGH POT-HOLING OR ALTERNATIVE METHOD. REPORT INFORMATION TO THE ENGINEER PRIOR TO CONSTRUCTION.



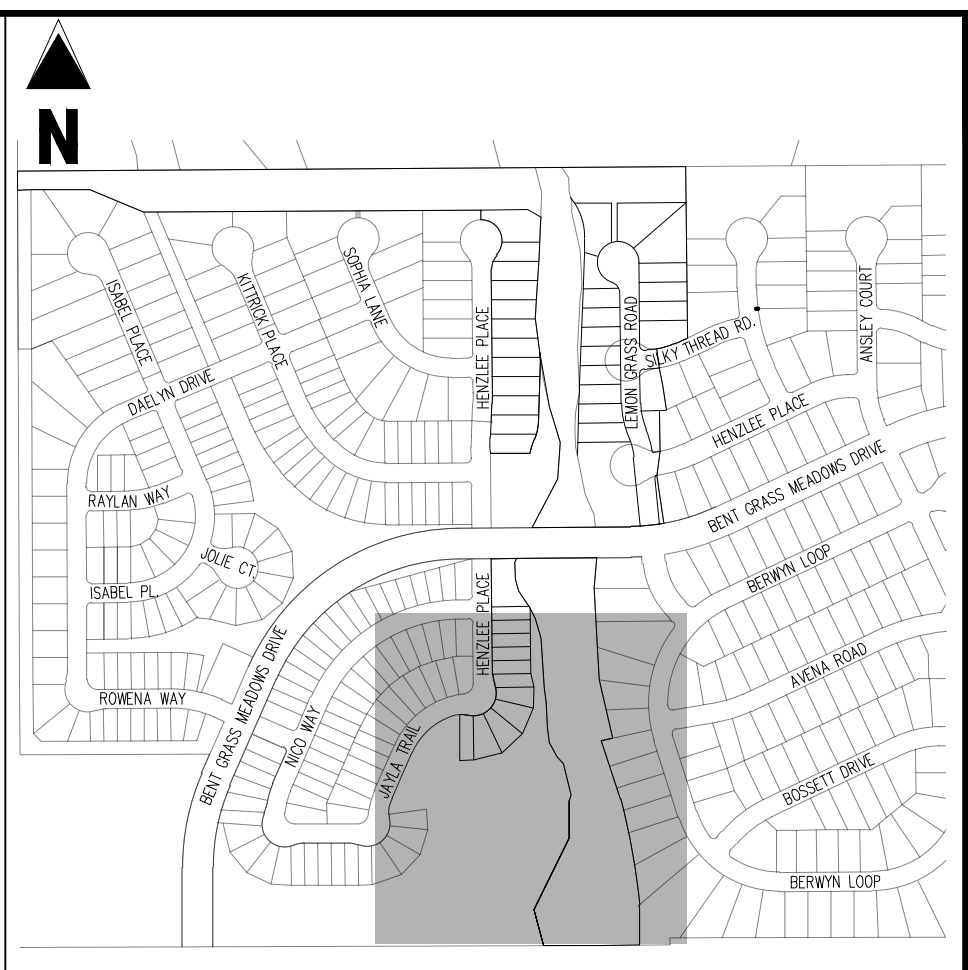
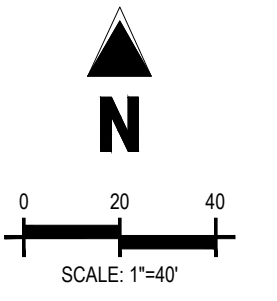

KEY MAP
SCALE: 1"=500'

EROSION CONTROL LEGEND

- LOD (LOD) LIMITS OF DISTURBANCE / CONSTRUCTION
SF (SF) SILT FENCE
CF (CF) CONSTRUCTION FENCE
IPS (IPS) SUMP INLET PROTECTION
IPO (IPO) ON-GRADE INLET PROTECTION
RS (RS) ROCK SOCKS
VTC (VTC) VEHICLE TRACKING CONTROL
CWA (CWA) CONCRETE WASHOUT AREA
SSA (SSA) STABILIZED STAGING AREA
SC (SC) PROPOSED SAWCUT LINE
PT (PT) PORTABLE TOILET
SP (SP) STOCKPILE
CD (CD) CHECK DAM
RR (RR) RIPRAP OUTFALL PADS
SITE (SITE) SITE (CONTACTS AND PERMITS)
WP (WP) WASHOUT POSTING
SBB (SBB) STRAW BALE BARRIER
SB (SB) SEDIMENT BASIN

NOTES

- 1. ADD 6900 TO ALL SPOT ELEVATIONS.
2. THE PLAN SHALL NOT SUBSTANTIALLY CHANGE THE DEPTH OF COVER, OR ACCESS TO UTILITY FACILITIES.
3. NO METLANDS ARE TO BE PERMANENTLY DISTURBED FOR THIS PLAN.
4. NO GRADING IS TO OCCUR WITHIN THE 100-YEAR FLOODPLAIN.
5. THE EROSION CONTROL DELINEATED ON THIS PLAN SHALL BE REGULARLY UPDATED BY THE CONTRACTORS.
6. CONTRACTOR SHALL PROTECT ALL AREAS OUTSIDE OF THE CONSTRUCTION LIMITS WITH SILT FENCE OR OTHER METHOD TO PROTECT UNDISTURBED AREAS FROM EROSION.
7. ALL TEMPORARY OR PERMANENT GRADING DISTURBANCES SHALL BE RE-SEEDING AND MULCHED PER EL PASO COUNTY CRITERIA AND SPECIFICATIONS.
8. ALL TEMPORARY RIPRAP SHOWN ON THE PLANS SHALL BE TYPE 'M'. RIPRAP SHALL BE PLACED IN THE LOCATIONS INDICATED BY THE PLAN OR IN AREAS AS THE CONTRACTOR SEES FIT TO CONTROL EROSION.
9. ALL TEMPORARY STORM DRAIN SHOWN ON THE PLANS SHALL BE 24" DIA. HP POLYPROPYLENE. ALL PIPE SHALL BE LAID TO ACHIEVE A MIN. SLOPE OF 0.5%.

EROSION CONTROL PHASING SCHEDULE

Table with 2 columns: PHASE (INITIAL, INTERM, FINAL) and DESCRIPTION of erosion control measures to be implemented at each stage.

LEGEND

- EXISTING PROPERTY LINE
PROPOSED PROJECT BOUNDARY
PROPOSED RIGHT OF WAY LINE
EXISTING LOT LINE
PROPOSED LOT LINE
EXISTING EASEMENT
PROPOSED EASEMENT
EXISTING SUBDIVISION BUFFER
EXISTING MAJOR CONTOUR
EXISTING MINOR CONTOUR
PROPOSED MAJOR CONTOUR
PROPOSED MINOR CONTOUR
EXISTING STORM DRAIN PIPE
PROPOSED STORM DRAIN PIPE
EXISTING WATER LINE
PROPOSED WATER LINE
EXISTING SANITARY SEWER LINE
PROPOSED SANITARY SEWER LINE
EXISTING DRAINAGE FEATURE OUTLINE
PROPOSED DRAINAGE FEATURE OUTLINE
EXISTING SWALE WITH FLOW DIRECTION
PROPOSED SWALE WITH FLOW DIRECTION
100-YEAR FEMA FLOODPLAIN
100-YEAR FLOODPLAIN 50-FT BUFFER
PROPOSED 1" TO 2" CRUSHED ROCK
PROPOSED RIP RAP
EXISTING CONCRETE PAVING
EXISTING CDOT CLASS 6 GRAVEL
EXISTING 1" TO 2" CRUSHED ROCK
EXISTING RIP RAP
EXISTING GROUDED BOULDERS
PROPOSED LOT #
EXISTING LOT # (BENT GRASS FILING NO. 2)
PROPOSED ADA RAMP
SPOT ELEVATION - HIGH POINT
SPOT ELEVATION - LOW POINT
SPOT ELEVATION - FINISH GRADE
EXISTING SLOPE (PERCENT)
EXISTING SLOPE (RISE:RUN)
PROPOSED SLOPE (PERCENT)
PROPOSED SLOPE (RISE:RUN)
FLOW ARROW

BASIS OF BEARINGS

ALL BEARINGS ARE GRID BEARINGS OF THE COLORADO STATE PLANE COORDINATE SYSTEM, CENTRAL ZONE, NORTH AMERICAN DATUM 1983.

BENCHMARK

THE SOUTHWESTERLY CORNER OF LOT 1 WOODMEN HILLS FILING NO. 4, MONUMENTED BY A YELLOW PLASTIC SURVEYORS CAP ON A NO. 4 REBAR L# 24954 ELEVATION = 6947.67

CAUTION - NOTICE TO CONTRACTOR

- 1. ALL UTILITY LOCATIONS SHOWN ARE BASED ON MAPS PROVIDED BY THE APPROPRIATE UTILITY COMPANY AND FIELD SURFACE EVIDENCE AT THE TIME OF SURVEY AND IS TO BE CONSIDERED AN APPROXIMATE LOCATION ONLY.
2. WHERE A PROPOSED UTILITY CROSSES AN EXISTING UTILITY, IT IS THE CONTRACTOR'S RESPONSIBILITY TO FIELD VERIFY THE HORIZONTAL AND VERTICAL LOCATION OF SUCH EXISTING UTILITY, EITHER THROUGH POTHOLES OR ALTERNATIVE METHOD. REPORT INFORMATION TO THE ENGINEER PRIOR TO CONSTRUCTION.



DEYOUNG RANDALL L
ZONE: 1-2
RECEPTION NO.: 208062874
PARCEL NO.: 530100016

1155 Kelly Johnson Blvd., Suite 305
Colorado Springs, CO 80920
719.900.7220
GallowayUS.com

COPYRIGHT
THESE PLANS ARE AN INSTRUMENT OF SERVICE AND ARE THE PROPERTY OF GALLOWAY, AND MAY NOT BE DUPLICATED, DISCLOSED, OR REPRODUCED WITHOUT THE WRITTEN CONSENT OF GALLOWAY. COPYRIGHTS AND INFRINGEMENTS WILL BE ENFORCED AND PROSECUTED.



CONSTRUCTION DOCUMENTS
FALCON MEADOWS AT BENT GRASS FILING NO. 4
FOR
CHALLENGER COMMUNITIES, LLC

BENT GRASS MEADOWS DRIVE & MERIDIAN ROAD
FALCON, CO 80831 - EL PASO COUNTY

Table with 4 columns: #, Date, Issue / Description, Init.

Project No: CLH000021
Drawn By: CMWJ
Checked By: RGD
Date: 05/XX/2021

GRADING & EROSION CONTROL INITIAL PLAN

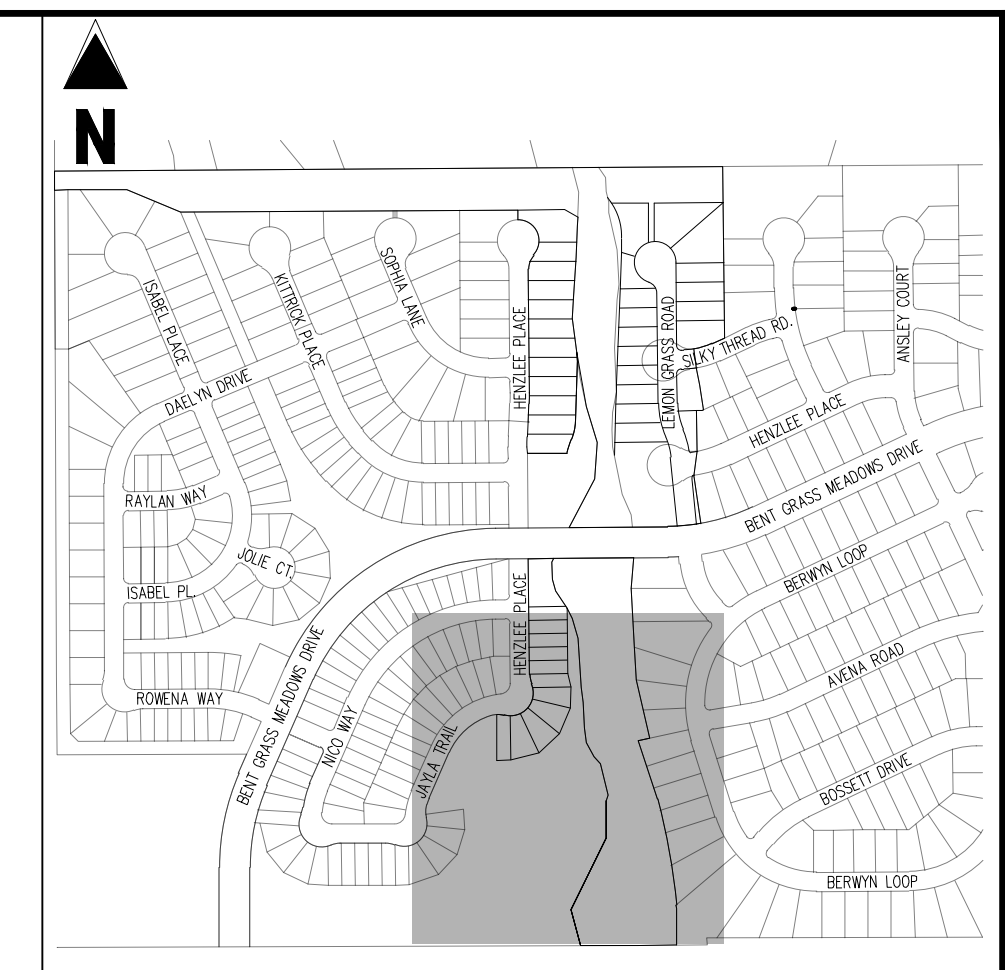
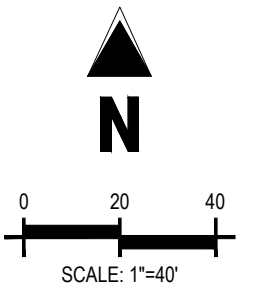
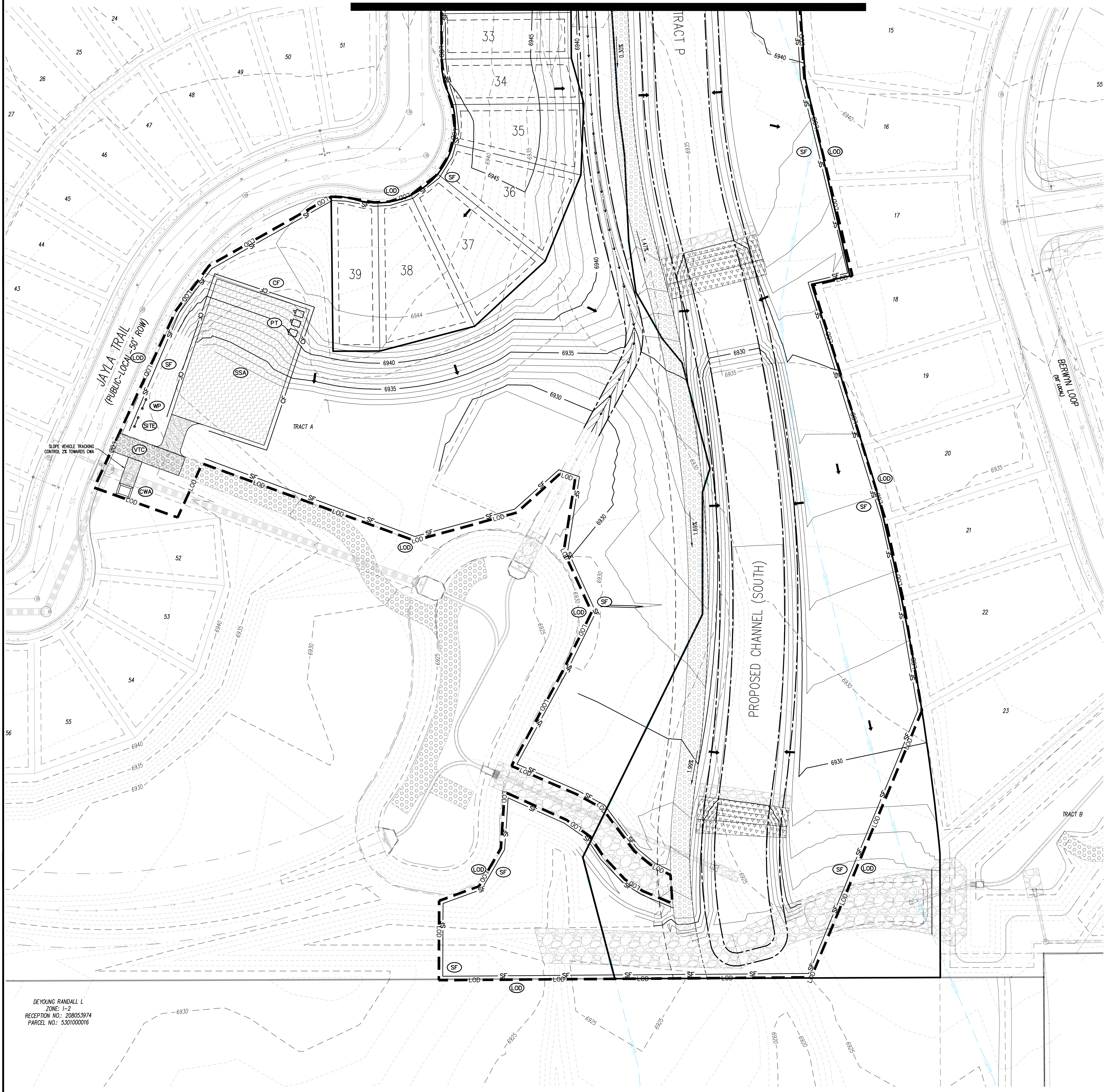

EROSION CONTROL LEGEND

- LOD (LOD) LIMITS OF DISTURBANCE / CONSTRUCTION
- SF (SF) SILT FENCE
- CF (CF) CONSTRUCTION FENCE
- (IPS) SUMP INLET PROTECTION
- (IPO) ON-GRADE INLET PROTECTION
- (RS) ROCK SOCKS
- (VTC) VEHICLE TRACKING CONTROL
- (CWA) CONCRETE WASHOUT AREA
- (SSA) STABILIZED STAGING AREA
- (SC) PROPOSED SAWCUT LINE
- (PT) PORTABLE TOILET
- (SP) STOCKPILE
- (CD) CHECK DAM
- (RR) RIPRAP OUTFALL PADS
- (SITE) SITE (CONTACTS AND PERMITS)
- (WP) WASHOUT POSTING
- (SBB) STRAW BALE BARRIER
- (SB) SEDIMENT BASIN

- NOTES**
- ADD 6900 TO ALL SPOT ELEVATIONS.
 - THE PLAN SHALL NOT SUBSTANTIALLY CHANGE THE DEPTH OF COVER, OR ACCESS TO UTILITY FACILITIES. ADDITIONALLY, THE PLAN SHALL NOT INCREASE OR DIVERT WATER TOWARDS UTILITY FACILITIES. ANY CHANGES TO UTILITY FACILITIES TO ACCOMMODATE THE PLAN, MUST BE DISCUSSED AND AGREED TO BY THE AFFECTED UTILITY PRIOR TO IMPLEMENTING THE PLAN. THE RESULTING COST TO RELOCATE PROTECT UTILITIES, OR PROVIDE INTERIM ACCESS IS AT THE EXPENSE OF THE PLAN APPLICANT.
 - NO METALS ARE TO BE PERMANENTLY DISTURBED FOR THIS PLAN.
 - NO GRADING IS TO OCCUR WITHIN THE 100-YEAR FLOODPLAIN.
 - THE EROSION CONTROL DELINEATED ON THIS PLAN SHALL BE REGULARLY UPDATED BY THE CONTRACTORS.
 - CONTRACTOR SHALL PROTECT ALL AREAS OUTSIDE OF THE CONSTRUCTION LIMITS WITH SILT FENCE OR OTHER METHOD TO PROTECT UNDISTURBED AREAS FROM EROSION.
 - ALL TEMPORARY OR PERMANENT GRADING DISTURBANCES SHALL BE RE-SEEDED AND MULCHED PER EL PASO COUNTY CRITERIA AND SPECIFICATIONS.
 - ALL TEMPORARY RIPRAP SHOWN ON THE PLANS SHALL BE TYPE "M". RIPRAP SHALL BE PLACED IN THE LOCATIONS INDICATED BY THE PLAN OR IN AREAS AS THE CONTRACTOR SEES FIT TO CONTROL EROSION. ALL RIPRAP SHALL BE PLACED AT A MINIMUM THICKNESS OF 1.5' DEEP.
 - ALL TEMPORARY STORM DRAIN SHOWN ON THE PLANS SHALL BE 24" DIA. HP POLYPROPYLENE. ALL PIPE SHALL BE LAID TO ACHIEVE A MIN. SLOPE OF 0.5%.

EROSION CONTROL PHASING SCHEDULE

PHASE	DESCRIPTION
INITIAL	INSTALL SILT FENCE, ALL INLET PROTECTION MEASURES ON EXISTING INLETS, AND CURB SOCKS ALONG BENT GRASS MEADOWS DRIVE
INTERIM	CONVERT EXISTING SEDIMENT BASIN FROM "EARLY GRADING & EROSION CONTROL PLANS" TO THE PROPOSED WATER QUALITY CAPTURE VOLUME DETENTION BASIN W/ ALL PERMANENT CONTROL MEASURES. THEN, INSTALL STABILIZED STAGING AREA, VEHICLE TRACKING CONTROL AT ENTRANCES, AND CONCRETE WASHOUT AREA. THEN OVERLOT GRADE THE ENTIRE PROJECT SITE AS SHOWN ON PLAN VIEW. INSTALL STRAW BALE BARRIERS ALONG INTERNAL ROADWAYS, AND INSTALL CHECK DAMS ALONG PROPOSED SWALES. FINALLY, INSTALL PROPOSED STORM SEWER. CONTRACTOR TO USE EXTREME CAUTION TO NOT DAMAGE THE WATER AND WASTEWATER IMPROVEMENTS COMPLETED IN THE EARLY METRO DISTRICT IMPROVEMENTS PLAN SET.
FINAL	CONSTRUCT CURB/GUTTER AND PAVEMENT. CONSTRUCT GAS/ELECTRIC/CABLE/PHONE IN ROW AREAS. REMOVE CONSTRUCTION BMP'S ONCE VERTICAL CONSTRUCTION OF HOUSES AND APPLICABLE LANDSCAPING IS COMPLETE.

LEGEND

- EXISTING PROPERTY LINE
- PROPOSED PROJECT BOUNDARY
- PROPOSED RIGHT OF WAY LINE
- EXISTING LOT LINE
- PROPOSED LOT LINE
- EXISTING EASEMENT
- PROPOSED EASEMENT
- EXISTING SUBDIVISION BUFFER
- EXISTING MAJOR CONTOUR
- EXISTING MINOR CONTOUR
- PROPOSED MAJOR CONTOUR
- PROPOSED MINOR CONTOUR
- EXISTING STORM DRAIN PIPE
- PROPOSED STORM DRAIN PIPE
- EXISTING WATER LINE
- PROPOSED WATER LINE
- EXISTING SANITARY SEWER LINE
- PROPOSED SANITARY SEWER LINE
- EXISTING DRAINAGE FEATURE OUTLINE
- PROPOSED DRAINAGE FEATURE OUTLINE
- EXISTING SWALE WITH FLOW DIRECTION
- PROPOSED SWALE WITH FLOW DIRECTION
- 100-YEAR FEMA FLOODPLAIN
- CUT / FILL
- 100-YEAR FLOODPLAIN 50-FT BUFFER
- PROPOSED 1" TO 2" CRUSHED ROCK
- PROPOSED RIP RAP
- EXISTING CONCRETE PAVING
- EXISTING CDOT CLASS 6 GRAVEL
- EXISTING 1" TO 2" CRUSHED ROCK
- EXISTING RIP RAP
- EXISTING GROUDED BOULDERS
- PROPOSED LOT #
- EXISTING LOT # (BENT GRASS FILING NO. 2)
- PROPOSED ADA RAMP
- 55.00 HP (HP) SPOT ELEVATION - HIGH POINT
- 55.00 LP (LP) SPOT ELEVATION - LOW POINT
- 55.00 FG (FG) SPOT ELEVATION - FINISH GRADE
- 2.00% (2.00%) EXISTING SLOPE (PERCENT)
- 4:1 (4:1) EXISTING SLOPE (RISE:RUN)
- 2.00% (2.00%) PROPOSED SLOPE (PERCENT)
- 4:1 (4:1) PROPOSED SLOPE (RISE:RUN)
- FLOW ARROW

BASIS OF BEARINGS

ALL BEARINGS ARE GRID BEARINGS OF THE COLORADO STATE PLANE COORDINATE SYSTEM, CENTRAL ZONE, NORTH AMERICAN DATUM 1983. THE BEARING OF THE LINE BETWEEN THE SOUTHWEST CORNER OF SECTION 1, T13S, R65W AND THE WEST QUARTER CORNER SECTION 1, T13S, R65W IS N007°14'41"W AND MONUMENTED AS SHOWN.

BENCHMARK

THE SOUTHWESTERLY CORNER OF LOT 1 WOODMEN HILLS FILING NO. 4, MONUMENTED BY A YELLOW PLASTIC SURVEYORS CAP ON A NO. 4 REBAR L# 24954 ELEVATION = 6947.67

CAUTION - NOTICE TO CONTRACTOR

- ALL UTILITY LOCATIONS SHOWN ARE BASED ON MAPS PROVIDED BY THE APPROPRIATE UTILITY COMPANY AND FIELD SURFACE EVIDENCE AT THE TIME OF SURVEY AND IS TO BE CONSIDERED AN APPROXIMATE LOCATION ONLY. IT IS THE CONTRACTOR'S RESPONSIBILITY TO FIELD VERIFY THE LOCATION OF ALL UTILITIES, PUBLIC OR PRIVATE, WHETHER SHOWN ON THE PLANS OR NOT, PRIOR TO CONSTRUCTION. REPORT ANY DISCREPANCIES TO THE ENGINEER PRIOR TO CONSTRUCTION.
- WHERE A PROPOSED UTILITY CROSSES AN EXISTING UTILITY, IT IS THE CONTRACTOR'S RESPONSIBILITY TO FIELD VERIFY THE HORIZONTAL AND VERTICAL LOCATION OF SUCH EXISTING UTILITY, EITHER THROUGH POT-HOLING OR ALTERNATIVE METHOD. REPORT INFORMATION TO THE ENGINEER PRIOR TO CONSTRUCTION.



Galloway
 1155 Kelly Johnson Blvd., Suite 305
 Colorado Springs, CO 80920
 719.900.7220
 GallowayUS.com

COPYRIGHT
 THESE PLANS ARE AN INSTRUMENT OF SERVICE AND ARE THE PROPERTY OF GALLOWAY. AND MAY NOT BE DUPLICATED, DISCLOSED, OR REPRODUCED WITHOUT THE WRITTEN CONSENT OF GALLOWAY. COPYRIGHTS AND INFRINGEMENTS WILL BE ENFORCED AND PROSECUTED.

CHALLENGER HOMES

CONSTRUCTION DOCUMENTS
 FALCON MEADOWS AT BENT GRASS FILING NO. 4
 FOR
 CHALLENGER COMMUNITIES, LLC
 BENT GRASS MEADOWS DRIVE & MERIDIAN ROAD
 FALCON, CO 80831 - EL PASO COUNTY

#	Date	Issue / Description	Init.

Project No: CLH000021
 Drawn By: CMWJ
 Checked By: RGD
 Date: 05/XX/2021

GRADING & EROSION CONTROL INTERIM PLAN

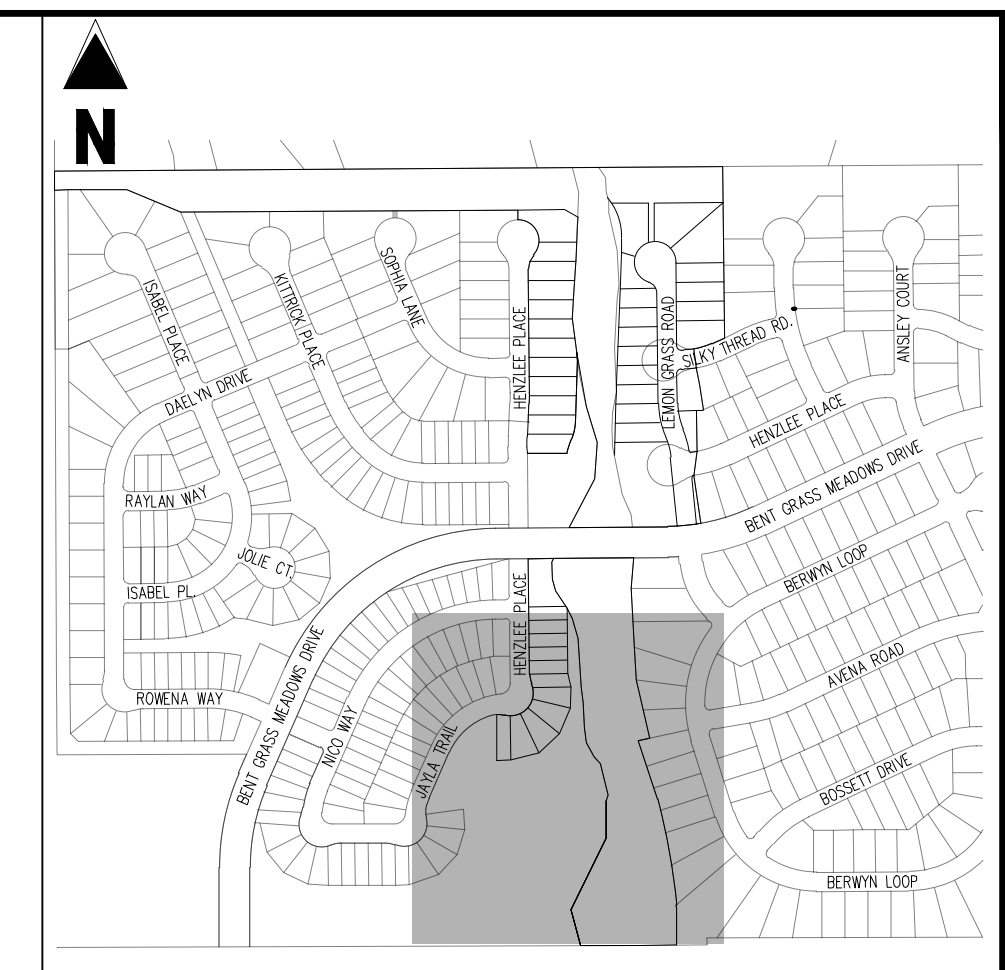
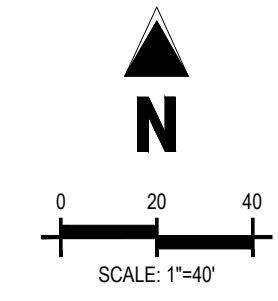

KEY MAP
SCALE: 1"=500'

EROSION CONTROL LEGEND

- LOD LIMITS OF DISTURBANCE / CONSTRUCTION
- SF SILT FENCE
- CF CONSTRUCTION FENCE
- IPS SUMP INLET PROTECTION
- IPO ON-GRADE INLET PROTECTION
- RS ROCK SOCKS
- VTC VEHICLE TRACKING CONTROL
- CWA CONCRETE WASHOUT AREA
- SSA STABILIZED STAGING AREA
- SC PROPOSED SAWCUT LINE
- PT PORTABLE TOILET
- SP STOCKPILE
- CD CHECK DAM
- RR RIPRAP OUTFALL PADS
- SITE SITE (CONTACTS AND PERMITS)
- WP WASHOUT POSTING
- SBB STRAW BALE BARRIER
- SB SEDIMENT BASIN

- NOTES**
1. ADD 6900 TO ALL SPOT ELEVATIONS.
 2. THE PLAN SHALL NOT SUBSTANTIALLY CHANGE THE DEPTH OF COVER, OR ACCESS TO UTILITY FACILITIES. ADDITIONALLY, THE PLAN SHALL NOT INCREASE OR DIVERT WATER TOWARDS UTILITY FACILITIES. ANY CHANGES TO UTILITY FACILITIES TO ACCOMMODATE THE PLAN, MUST BE DISCUSSED AND AGREED TO BY THE AFFECTED UTILITY PRIOR TO IMPLEMENTING THE PLAN. THE RESULTING COST TO RELOCATE PROTECT UTILITIES, OR PROVIDE INTERIM ACCESS IS AT THE EXPENSE OF THE PLAN APPLICANT.
 3. NO METALS ARE TO BE PERMANENTLY DISTURBED FOR THIS PLAN.
 4. NO GRADING IS TO OCCUR WITHIN THE 100-YEAR FLOODPLAIN.
 5. THE EROSION CONTROL DELINEATED ON THIS PLAN SHALL BE REGULARLY UPDATED BY THE CONTRACTOR.
 6. CONTRACTOR SHALL PROTECT ALL AREAS OUTSIDE OF THE CONSTRUCTION LIMITS WITH SILT FENCE OR OTHER METHOD TO PROTECT UNDISTURBED AREAS FROM EROSION.
 7. ALL TEMPORARY OR PERMANENT GRADING DISTURBANCES SHALL BE RE-SEEDED AND MULCHED PER EL PASO COUNTY CRITERIA AND SPECIFICATIONS.
 8. ALL TEMPORARY RIPRAP SHOWN ON THE PLANS SHALL BE TYPE "M" RIPRAP SHALL BE PLACED IN THE LOCATIONS INDICATED BY THE PLAN OR IN AREAS AS THE CONTRACTOR SEES FIT TO CONTROL EROSION. ALL RIPRAP SHALL BE PLACED AT A MINIMUM THICKNESS OF 1.5' DEEP.
 9. ALL TEMPORARY STORM DRAIN SHOWN ON THE PLANS SHALL BE 24" DIA. HP POLYPROPYLENE. ALL PIPE SHALL BE LAID TO ACHIEVE A MIN. SLOPE OF 0.5%.
 10. ALL TEMPORARY STORM DRAIN SHOWN ON THE PLANS SHALL BE 24" DIA. HP POLYPROPYLENE. ALL PIPE SHALL BE LAID TO ACHIEVE A MIN. SLOPE OF 0.5%.

EROSION CONTROL PHASING SCHEDULE

PHASE	DESCRIPTION
INITIAL	INSTALL SILT FENCE, ALL INLET PROTECTION MEASURES ON EXISTING INLETS, AND CURB SOCKS ALONG BENT GRASS MEADOWS DRIVE
INTERM	CONVERT EXISTING SEDIMENT BASIN FROM "EARLY GRADING & EROSION CONTROL PLANS" TO THE PROPOSED WATER QUALITY CAPTURE VOLUME DETENTION BASIN W/ ALL PERMANENT CONTROL MEASURES. THEN, INSTALL STABILIZED STAGING AREA, VEHICLE TRACKING CONTROL AT ENTRANCES, AND CONCRETE WASHOUT AREA. THEN OVERLOT GRADE THE ENTIRE PROJECT SITE AS SHOWN ON PLAN VIEW, INSTALL STRAW BALE BARRIERS ALONG INTERNAL ROADWAYS, AND INSTALL CHECK DAMS ALONG PROPOSED SWALES. FINALLY, INSTALL PROPOSED STORM SEWER. CONTRACTOR TO USE EXTREME CAUTION TO NOT DAMAGE THE WATER AND WASTEWATER IMPROVEMENTS COMPLETED IN THE EARLY METRO DISTRICT IMPROVEMENTS PLAN SET.
FINAL	CONSTRUCT CURB/GUTTER AND PAVEMENT. CONSTRUCT GAS/ELECTRIC/CABLE/PHONE IN ROW AREAS. REMOVE CONSTRUCTION BMP'S ONCE VERTICAL CONSTRUCTION OF HOUSES AND APPLICABLE LANDSCAPING IS COMPLETE.

LEGEND

- EXISTING PROPERTY LINE
- PROPOSED PROJECT BOUNDARY
- PROPOSED RIGHT OF WAY LINE
- EXISTING LOT LINE
- PROPOSED LOT LINE
- EXISTING EASEMENT
- PROPOSED EASEMENT
- EXISTING SUBDIVISION BUFFER
- EXISTING MAJOR CONTOUR
- EXISTING MINOR CONTOUR
- PROPOSED MAJOR CONTOUR
- PROPOSED MINOR CONTOUR
- EXISTING STORM DRAIN PIPE
- PROPOSED STORM DRAIN PIPE
- EXISTING WATER LINE
- PROPOSED WATER LINE
- EXISTING SANITARY SEWER LINE
- PROPOSED SANITARY SEWER LINE
- EXISTING DRAINAGE FEATURE OUTLINE
- PROPOSED DRAINAGE FEATURE OUTLINE
- EXISTING SWALE WITH FLOW DIRECTION
- PROPOSED SWALE WITH FLOW DIRECTION
- 100-YEAR FEMA FLOODPLAIN
- 100-YEAR FLOODPLAIN 50-FT BUFFER
- PROPOSED 1" TO 2" CRUSHED ROCK
- PROPOSED RIP RAP
- EXISTING CONCRETE PAVING
- EXISTING CDOT CLASS 6 GRAVEL
- EXISTING 1" TO 2" CRUSHED ROCK
- EXISTING RIP RAP
- EXISTING GROOVED BOULDERS
- PROPOSED LOT # (BENT GRASS FILING NO. 2)
- EXISTING LOT # (BENT GRASS FILING NO. 2)
- PROPOSED ADA RAMP
- SPOT ELEVATION - HIGH POINT
- SPOT ELEVATION - LOW POINT
- SPOT ELEVATION - FINISH GRADE
- EXISTING SLOPE (PERCENT)
- EXISTING SLOPE (RISE:RUN)
- PROPOSED SLOPE (PERCENT)
- PROPOSED SLOPE (RISE:RUN)
- FLOW ARROW

BASIS OF BEARINGS
ALL BEARINGS ARE GRID BEARINGS OF THE COLORADO STATE PLANE COORDINATE SYSTEM, CENTRAL ZONE, NORTH AMERICAN DATUM 1983. THE BEARING OF THE LINE BETWEEN THE SOUTHWEST CORNER OF SECTION 1, T13S, R65W AND THE WEST QUARTER CORNER SECTION 1, T13S, R65W IS N001°34'46" W AND MONUMENTED AS SHOWN.

BENCHMARK
THE SOUTHWESTERLY CORNER OF LOT 1 WOODMEN HILLS FILING NO. 4, MONUMENTED BY A YELLOW PLASTIC SURVEYORS CAP ON A NO. 4 REBAR L# 24954 ELEVATION = 6947.67

CAUTION - NOTICE TO CONTRACTOR
1. ALL UTILITY LOCATIONS SHOWN ARE BASED ON MAPS PROVIDED BY THE APPROPRIATE UTILITY COMPANY AND FIELD SURFACE EVIDENCE AT THE TIME OF SURVEY AND IS TO BE CONSIDERED AN APPROXIMATE LOCATION ONLY. IT IS THE CONTRACTOR'S RESPONSIBILITY TO FIELD VERIFY THE LOCATION OF ALL UTILITIES, PUBLIC OR PRIVATE, WHETHER SHOWN ON THE PLANS OR NOT, PRIOR TO CONSTRUCTION. REPORT ANY DISCREPANCIES TO THE ENGINEER PRIOR TO CONSTRUCTION.
2. WHERE A PROPOSED UTILITY CROSSES AN EXISTING UTILITY, IT IS THE CONTRACTOR'S RESPONSIBILITY TO FIELD VERIFY THE HORIZONTAL AND VERTICAL LOCATION OF SUCH EXISTING UTILITY, EITHER THROUGH POT-HOLING OR ALTERNATIVE METHOD. REPORT INFORMATION TO THE ENGINEER PRIOR TO CONSTRUCTION.



DEYOUNG RANDALL L
ZONE: 1-2
RECEPTION NO.: 208062874
PARCEL NO.: 530100016

Galloway
1155 Kelly Johnson Blvd., Suite 305
Colorado Springs, CO 80920
719.900.7220
GallowayUS.com

COPYRIGHT
THESE PLANS ARE AN INSTRUMENT OF SERVICE AND ARE THE PROPERTY OF GALLOWAY, AND MAY NOT BE DUPLICATED, DISCLOSED, OR REPRODUCED WITHOUT THE WRITTEN CONSENT OF GALLOWAY. COPYRIGHTS AND INFRINGEMENTS WILL BE ENFORCED AND PROSECUTED.

CHALLENGER HOMES

CONSTRUCTION DOCUMENTS
FALCON MEADOWS AT BENT GRASS FILING NO. 4
FOR
CHALLENGER COMMUNITIES, LLC
BENT GRASS MEADOWS DRIVE & MERIDIAN ROAD
FALCON, CO 80831 - EL PASO COUNTY

#	Date	Issue / Description	Init.

Project No: CLH000021
Drawn By: CMWJ
Checked By: RGD
Date: 05/09/2021

GRADING & EROSION CONTROL FINAL PLAN

G3.3
Sheet 13 of 25

COPYRIGHT
 THESE PLANS ARE AN INSTRUMENT OF SERVICE AND ARE THE PROPERTY OF GALLOWAY, AND MAY NOT BE DUPLICATED, DISCLOSED, OR REPRODUCED WITHOUT THE WRITTEN CONSENT OF GALLOWAY. COPYRIGHTS AND INFRINGEMENTS WILL BE ENFORCED AND PROSECUTED.



CONSTRUCTION DOCUMENTS
 FALCON MEADOWS AT BENT GRASS FILING NO. 4
 FOR
 CHALLENGER COMMUNITIES, LLC

BENT GRASS MEADOWS DRIVE & MERIDIAN ROAD
 FALCON, CO 80831 - EL PASO COUNTY

#	Date	Issue / Description	Init.

Project No: CLH000021
 Drawn By: CMWJ
 Checked By: RGJ
 Date: 05/XX/2021

KEY MAP

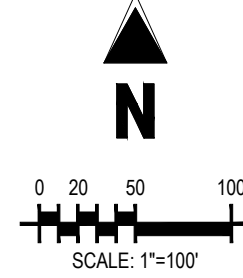

LEGEND

- EXISTING PROPERTY LINE
- PROPOSED RIGHT OF WAY LINE
- - - EXISTING LOT LINE
- - - PROPOSED LOT LINE
- - - EXISTING EASEMENT
- - - PROPOSED EASEMENT
- - - EXISTING SUBDIVISION BUFFER
- - - EXISTING MAJOR CONTOUR
- - - EXISTING MINOR CONTOUR
- - - PROPOSED MAJOR CONTOUR
- - - PROPOSED MINOR CONTOUR
- EXISTING STORM DRAIN PIPE
- PROPOSED STORM DRAIN PIPE
- EXISTING WATER LINE
- PROPOSED WATER LINE
- SS EXISTING SANITARY SEWER LINE
- SS PROPOSED SANITARY SEWER LINE
- - - EXISTING DRAINAGE FEATURE OUTLINE
- - - PROPOSED DRAINAGE FEATURE OUTLINE
- EXISTING SWALE WITH FLOW DIRECTION
- PROPOSED SWALE WITH FLOW DIRECTION
- 100-YEAR FEMA FLOODPLAIN
- - - CUT / FILL
- - - 100-YEAR FLOODPLAIN 50-FT BUFFER
- - - PROPOSED 1" TO 2" CRUSHED ROCK
- - - PROPOSED RIP RAP
- - - EXISTING CONCRETE PAVING
- - - EXISTING CDOT CLASS 6 GRAVEL
- - - EXISTING 1" TO 2" CRUSHED ROCK
- - - EXISTING RIP RAP
- - - EXISTING GROUTED BOULDERS
- 113 PROPOSED LOT #
- 101 EXISTING LOT # (BENT GRASS FILING NO. 2)
- 55.00 HP PROPOSED ADA RAMP
- 55.00 HP SPOT ELEVATION - HIGH POINT
- 55.00 LP SPOT ELEVATION - LOW POINT
- 55.00 FT SPOT ELEVATION - FINISH GRADE
- 2.00% EXISTING SLOPE (PERCENT)
- 4:1 EXISTING SLOPE (RISE:RUN)
- 2.00% PROPOSED SLOPE (PERCENT)
- 4:1 PROPOSED SLOPE (RISE:RUN)
- FLOW ARROW

NOTES

1. ADD 6900 TO ALL SPOT ELEVATIONS
2. THE PLAN SHALL NOT SUBSTANTIALLY CHANGE THE DEPTH OF COVER, OR ACCESS TO UTILITY FACILITIES. ADDITIONALLY, THE PLAN SHALL NOT INCREASE OR DIVERT WATER TOWARDS UTILITY FACILITIES. ANY CHANGES TO UTILITY FACILITIES TO ACCOMMODATE THE PLAN, MUST BE DISCUSSED AND AGREED TO BY THE AFFECTED UTILITY PRIOR TO IMPLEMENTING THE PLAN. THE RESULTING COST TO RELOCATE OR PROTECT UTILITIES, OR PROVIDE INTERIM ACCESS IS AT THE EXPENSE OF THE PLAN APPLICANT.

EROSION CONTROL PHASING SCHEDULE

PHASE	DESCRIPTION
INITIAL	INSTALL SILT FENCE, ALL INLET PROTECTION MEASURES ON EXISTING INLETS, AND CURB SOCKS ALONG BENT GRASS MEADOWS DRIVE
INTERIM	CONVERT EXISTING SEDIMENT BASIN FROM "EARLY GRADING & EROSION CONTROL PLANS" TO THE PROPOSED WATER QUALITY CAPTURE VOLUME DETENTION BASIN W/ ALL PERMANENT CONTROL MEASURES. THEN, INSTALL STABILIZED STAGING AREA, VEHICLE TRACKING CONTROL AT ENTRANCES, AND CONCRETE WASHOUT AREA. THEN OVERLOT GRADE THE ENTIRE PROJECT SITE AS SHOWN ON PLAN VIEW. INSTALL STRAW BALE BARRIERS ALONG INTERNAL ROADWAYS, AND INSTALL CHECK DAMS ALONG PROPOSED SWALES. FINALLY, INSTALL PROPOSED STORM SEWER. CONTRACTOR TO USE EXTREME CAUTION TO NOT DAMAGE THE WATER AND WASTEWATER IMPROVEMENTS COMPLETED IN THE EARLY METRO DISTRICT IMPROVEMENTS PLAN SET.
FINAL	CONSTRUCT CURB/GUTTER AND PAVEMENT. CONSTRUCT GAS/ELECTRIC/CABLE/PHONE IN ROW AREAS. REMOVE CONSTRUCTION BMP'S ONCE VERTICAL CONSTRUCTION OF HOUSES AND APPLICABLE LANDSCAPING IS COMPLETE.

BASIS OF BEARINGS

ALL BEARINGS ARE GRID BEARINGS OF THE COLORADO STATE PLANE COORDINATE SYSTEM, CENTRAL ZONE, NORTH AMERICAN DATUM 1983. THE BEARING OF THE LINE BETWEEN THE SOUTHWEST CORNER OF SECTION 1, T13S, R65W AND THE WEST QUARTER CORNER SECTION 1, T13S, R65W IS N001°34'48"W AND MONUMENTED AS SHOWN.

BENCHMARK

THE SOUTHWESTERLY CORNER OF LOT 1 WOODMEN HILLS FILING NO. 4, MONUMENTED BY A YELLOW PLASTIC SURVEYORS CAP ON A NO. 4 REBAR L5/4 24954 ELEVATION = 6947.67

CAUTION - NOTICE TO CONTRACTOR

1. ALL UTILITY LOCATIONS SHOWN ARE BASED ON MAPS PROVIDED BY THE APPROPRIATE UTILITY COMPANY AND FIELD SURFACE EVIDENCE AT THE TIME OF SURVEY AND IS TO BE CONSIDERED AN APPROXIMATE LOCATION ONLY. IT IS THE CONTRACTOR'S RESPONSIBILITY TO FIELD VERIFY THE FIELD LOCATION OF ALL UTILITIES, PUBLIC OR PRIVATE, WHETHER SHOWN ON THE PLANS OR NOT, PRIOR TO CONSTRUCTION. REPORT ANY DISCREPANCIES TO THE ENGINEER PRIOR TO CONSTRUCTION.
2. WHERE A PROPOSED UTILITY CROSSES AN EXISTING UTILITY, IT IS THE CONTRACTOR'S RESPONSIBILITY TO FIELD VERIFY THE HORIZONTAL AND VERTICAL LOCATION OF SUCH EXISTING UTILITY, EITHER THROUGH POT-HOLING OR ALTERNATIVE METHOD. REPORT INFORMATION TO THE ENGINEER PRIOR TO CONSTRUCTION.



ZONE: RR-5 PLAT NO.: 10713 PARCEL NO.: 5301005033
 ZONE: RR-5 PLAT NO.: 10713 PARCEL NO.: 5301005034
 ZONE: RR-5 PLAT NO.: 10713 PARCEL NO.: 5301005035
 ZONE: RR-5 PLAT NO.: 10713 PARCEL NO.: 5301005043
 PLAT # PARCEL NO.

LOT 1, THE MEADOWS FILING NO. 2
 ZONE: RR-5 PLAT NO.: 10713 PARCEL NO.: 5302001004
 LOT 2, THE MEADOWS FILING NO. 2
 ZONE: RR-5 PLAT NO.: 10713 PARCEL NO.: 5302001005
 LOT 3, THE MEADOWS FILING NO. 2
 ZONE: RR-5 PLAT NO.: 10713 PARCEL NO.: 5302001006
 LOT 4, THE MEADOWS FILING NO. 2
 ZONE: RR-5 PLAT NO.: 10713 PARCEL NO.: 5302001007
 LOT 5, THE MEADOWS FILING NO. 2
 ZONE: RR-5 PLAT NO.: 10713 PARCEL NO.: 5302001008
 LOT 6, THE MEADOWS FILING NO. 2
 ZONE: RR-5 PLAT NO.: 10713 PARCEL NO.: 5302001009
 LOT 7, THE MEADOWS FILING NO. 2
 ZONE: RR-5 PLAT NO.: 10713 PARCEL NO.: 5302001010
 LOT 8, THE MEADOWS FILING NO. 2
 ZONE: RR-5 PLAT NO.: 10713 PARCEL NO.: 5302001011
 LOT 9, THE MEADOWS FILING NO. 2
 ZONE: RR-5 PLAT NO.: 10713 PARCEL NO.: 5302001012
 LOT 10, THE MEADOWS FILING NO. 2
 ZONE: RR-5 PLAT NO.: 10713 PARCEL NO.: 5302001013
 LOT 11, THE MEADOWS FILING NO. 2
 ZONE: RR-5 PLAT NO.: 10713 PARCEL NO.: 5302001014
 LOT 12, THE MEADOWS FILING NO. 2
 ZONE: RR-5 PLAT NO.: 10713 PARCEL NO.: 5302001015
 LOT 13, THE MEADOWS FILING NO. 2
 ZONE: RR-5 PLAT NO.: 10713 PARCEL NO.: 5302001016
 LOT 14, THE MEADOWS FILING NO. 2
 ZONE: RR-5 PLAT NO.: 10713 PARCEL NO.: 5302001017
 LOT 15, THE MEADOWS FILING NO. 2
 ZONE: RR-5 PLAT NO.: 10713 PARCEL NO.: 5302001018
 LOT 16, THE MEADOWS FILING NO. 2
 ZONE: RR-5 PLAT NO.: 10713 PARCEL NO.: 5302001019
 LOT 17, THE MEADOWS FILING NO. 2
 ZONE: RR-5 PLAT NO.: 10713 PARCEL NO.: 5302001020
 LOT 18, THE MEADOWS FILING NO. 2
 ZONE: RR-5 PLAT NO.: 10713 PARCEL NO.: 5302001021
 LOT 19, THE MEADOWS FILING NO. 2
 ZONE: RR-5 PLAT NO.: 10713 PARCEL NO.: 5302001022
 LOT 20, THE MEADOWS FILING NO. 2
 ZONE: RR-5 PLAT NO.: 10713 PARCEL NO.: 5302001023
 LOT 21, THE MEADOWS FILING NO. 2
 ZONE: RR-5 PLAT NO.: 10713 PARCEL NO.: 5302001024
 LOT 22, THE MEADOWS FILING NO. 2
 ZONE: RR-5 PLAT NO.: 10713 PARCEL NO.: 5302001025
 LOT 23, THE MEADOWS FILING NO. 2
 ZONE: RR-5 PLAT NO.: 10713 PARCEL NO.: 5302001026
 LOT 24, THE MEADOWS FILING NO. 2
 ZONE: RR-5 PLAT NO.: 10713 PARCEL NO.: 5302001027
 LOT 25, THE MEADOWS FILING NO. 2
 ZONE: RR-5 PLAT NO.: 10713 PARCEL NO.: 5302001028
 LOT 26, THE MEADOWS FILING NO. 2
 ZONE: RR-5 PLAT NO.: 10713 PARCEL NO.: 5302001029
 LOT 27, THE MEADOWS FILING NO. 2
 ZONE: RR-5 PLAT NO.: 10713 PARCEL NO.: 5302001030
 LOT 28, THE MEADOWS FILING NO. 2
 ZONE: RR-5 PLAT NO.: 10713 PARCEL NO.: 5302001031
 LOT 29, THE MEADOWS FILING NO. 2
 ZONE: RR-5 PLAT NO.: 10713 PARCEL NO.: 5302001032
 LOT 30, THE MEADOWS FILING NO. 2
 ZONE: RR-5 PLAT NO.: 10713 PARCEL NO.: 5302001033
 LOT 31, THE MEADOWS FILING NO. 2
 ZONE: RR-5 PLAT NO.: 10713 PARCEL NO.: 5302001034
 LOT 32, THE MEADOWS FILING NO. 2
 ZONE: RR-5 PLAT NO.: 10713 PARCEL NO.: 5302001035
 LOT 33, THE MEADOWS FILING NO. 2
 ZONE: RR-5 PLAT NO.: 10713 PARCEL NO.: 5302001036
 LOT 34, THE MEADOWS FILING NO. 2
 ZONE: RR-5 PLAT NO.: 10713 PARCEL NO.: 5302001037
 LOT 35, THE MEADOWS FILING NO. 2
 ZONE: RR-5 PLAT NO.: 10713 PARCEL NO.: 5302001038
 LOT 36, THE MEADOWS FILING NO. 2
 ZONE: RR-5 PLAT NO.: 10713 PARCEL NO.: 5302001039
 LOT 37, THE MEADOWS FILING NO. 2
 ZONE: RR-5 PLAT NO.: 10713 PARCEL NO.: 5302001040
 LOT 38, THE MEADOWS FILING NO. 2
 ZONE: RR-5 PLAT NO.: 10713 PARCEL NO.: 5302001041
 LOT 39, THE MEADOWS FILING NO. 2
 ZONE: RR-5 PLAT NO.: 10713 PARCEL NO.: 5302001042
 LOT 40, THE MEADOWS FILING NO. 2
 ZONE: RR-5 PLAT NO.: 10713 PARCEL NO.: 5302001043
 LOT 41, THE MEADOWS FILING NO. 2
 ZONE: RR-5 PLAT NO.: 10713 PARCEL NO.: 5302001044
 LOT 42, THE MEADOWS FILING NO. 2
 ZONE: RR-5 PLAT NO.: 10713 PARCEL NO.: 5302001045
 LOT 43, THE MEADOWS FILING NO. 2
 ZONE: RR-5 PLAT NO.: 10713 PARCEL NO.: 5302001046
 LOT 44, THE MEADOWS FILING NO. 2
 ZONE: RR-5 PLAT NO.: 10713 PARCEL NO.: 5302001047
 LOT 45, THE MEADOWS FILING NO. 2
 ZONE: RR-5 PLAT NO.: 10713 PARCEL NO.: 5302001048
 LOT 46, THE MEADOWS FILING NO. 2
 ZONE: RR-5 PLAT NO.: 10713 PARCEL NO.: 5302001049
 LOT 47, THE MEADOWS FILING NO. 2
 ZONE: RR-5 PLAT NO.: 10713 PARCEL NO.: 5302001050
 LOT 48, THE MEADOWS FILING NO. 2
 ZONE: RR-5 PLAT NO.: 10713 PARCEL NO.: 5302001051
 LOT 49, THE MEADOWS FILING NO. 2
 ZONE: RR-5 PLAT NO.: 10713 PARCEL NO.: 5302001052
 LOT 50, THE MEADOWS FILING NO. 2
 ZONE: RR-5 PLAT NO.: 10713 PARCEL NO.: 5302001053
 LOT 51, THE MEADOWS FILING NO. 2
 ZONE: RR-5 PLAT NO.: 10713 PARCEL NO.: 5302001054
 LOT 52, THE MEADOWS FILING NO. 2
 ZONE: RR-5 PLAT NO.: 10713 PARCEL NO.: 5302001055
 LOT 53, THE MEADOWS FILING NO. 2
 ZONE: RR-5 PLAT NO.: 10713 PARCEL NO.: 5302001056
 LOT 54, THE MEADOWS FILING NO. 2
 ZONE: RR-5 PLAT NO.: 10713 PARCEL NO.: 5302001057
 LOT 55, THE MEADOWS FILING NO. 2
 ZONE: RR-5 PLAT NO.: 10713 PARCEL NO.: 5302001058
 LOT 56, THE MEADOWS FILING NO. 2
 ZONE: RR-5 PLAT NO.: 10713 PARCEL NO.: 5302001059
 LOT 57, THE MEADOWS FILING NO. 2
 ZONE: RR-5 PLAT NO.: 10713 PARCEL NO.: 5302001060
 LOT 58, THE MEADOWS FILING NO. 2
 ZONE: RR-5 PLAT NO.: 10713 PARCEL NO.: 5302001061
 LOT 59, THE MEADOWS FILING NO. 2
 ZONE: RR-5 PLAT NO.: 10713 PARCEL NO.: 5302001062
 LOT 60, THE MEADOWS FILING NO. 2
 ZONE: RR-5 PLAT NO.: 10713 PARCEL NO.: 5302001063
 LOT 61, THE MEADOWS FILING NO. 2
 ZONE: RR-5 PLAT NO.: 10713 PARCEL NO.: 5302001064
 LOT 62, THE MEADOWS FILING NO. 2
 ZONE: RR-5 PLAT NO.: 10713 PARCEL NO.: 5302001065
 LOT 63, THE MEADOWS FILING NO. 2
 ZONE: RR-5 PLAT NO.: 10713 PARCEL NO.: 5302001066
 LOT 64, THE MEADOWS FILING NO. 2
 ZONE: RR-5 PLAT NO.: 10713 PARCEL NO.: 5302001067
 LOT 65, THE MEADOWS FILING NO. 2
 ZONE: RR-5 PLAT NO.: 10713 PARCEL NO.: 5302001068
 LOT 66, THE MEADOWS FILING NO. 2
 ZONE: RR-5 PLAT NO.: 10713 PARCEL NO.: 5302001069
 LOT 67, THE MEADOWS FILING NO. 2
 ZONE: RR-5 PLAT NO.: 10713 PARCEL NO.: 5302001070
 LOT 68, THE MEADOWS FILING NO. 2
 ZONE: RR-5 PLAT NO.: 10713 PARCEL NO.: 5302001071
 LOT 69, THE MEADOWS FILING NO. 2
 ZONE: RR-5 PLAT NO.: 10713 PARCEL NO.: 5302001072
 LOT 70, THE MEADOWS FILING NO. 2
 ZONE: RR-5 PLAT NO.: 10713 PARCEL NO.: 5302001073
 LOT 71, THE MEADOWS FILING NO. 2
 ZONE: RR-5 PLAT NO.: 10713 PARCEL NO.: 5302001074
 LOT 72, THE MEADOWS FILING NO. 2
 ZONE: RR-5 PLAT NO.: 10713 PARCEL NO.: 5302001075
 LOT 73, THE MEADOWS FILING NO. 2
 ZONE: RR-5 PLAT NO.: 10713 PARCEL NO.: 5302001076
 LOT 74, THE MEADOWS FILING NO. 2
 ZONE: RR-5 PLAT NO.: 10713 PARCEL NO.: 5302001077
 LOT 75, THE MEADOWS FILING NO. 2
 ZONE: RR-5 PLAT NO.: 10713 PARCEL NO.: 5302001078
 LOT 76, THE MEADOWS FILING NO. 2
 ZONE: RR-5 PLAT NO.: 10713 PARCEL NO.: 5302001079
 LOT 77, THE MEADOWS FILING NO. 2
 ZONE: RR-5 PLAT NO.: 10713 PARCEL NO.: 5302001080
 LOT 78, THE MEADOWS FILING NO. 2
 ZONE: RR-5 PLAT NO.: 10713 PARCEL NO.: 5302001081
 LOT 79, THE MEADOWS FILING NO. 2
 ZONE: RR-5 PLAT NO.: 10713 PARCEL NO.: 5302001082
 LOT 80, THE MEADOWS FILING NO. 2
 ZONE: RR-5 PLAT NO.: 10713 PARCEL NO.: 5302001083
 LOT 81, THE MEADOWS FILING NO. 2
 ZONE: RR-5 PLAT NO.: 10713 PARCEL NO.: 5302001084
 LOT 82, THE MEADOWS FILING NO. 2
 ZONE: RR-5 PLAT NO.: 10713 PARCEL NO.: 5302001085
 LOT 83, THE MEADOWS FILING NO. 2
 ZONE: RR-5 PLAT NO.: 10713 PARCEL NO.: 5302001086
 LOT 84, THE MEADOWS FILING NO. 2
 ZONE: RR-5 PLAT NO.: 10713 PARCEL NO.: 5302001087
 LOT 85, THE MEADOWS FILING NO. 2
 ZONE: RR-5 PLAT NO.: 10713 PARCEL NO.: 5302001088
 LOT 86, THE MEADOWS FILING NO. 2
 ZONE: RR-5 PLAT NO.: 10713 PARCEL NO.: 5302001089
 LOT 87, THE MEADOWS FILING NO. 2
 ZONE: RR-5 PLAT NO.: 10713 PARCEL NO.: 5302001090
 LOT 88, THE MEADOWS FILING NO. 2
 ZONE: RR-5 PLAT NO.: 10713 PARCEL NO.: 5302001091
 LOT 89, THE MEADOWS FILING NO. 2
 ZONE: RR-5 PLAT NO.: 10713 PARCEL NO.: 5302001092
 LOT 90, THE MEADOWS FILING NO. 2
 ZONE: RR-5 PLAT NO.: 10713 PARCEL NO.: 5302001093
 LOT 91, THE MEADOWS FILING NO. 2
 ZONE: RR-5 PLAT NO.: 10713 PARCEL NO.: 5302001094
 LOT 92, THE MEADOWS FILING NO. 2
 ZONE: RR-5 PLAT NO.: 10713 PARCEL NO.: 5302001095
 LOT 93, THE MEADOWS FILING NO. 2
 ZONE: RR-5 PLAT NO.: 10713 PARCEL NO.: 5302001096
 LOT 94, THE MEADOWS FILING NO. 2
 ZONE: RR-5 PLAT NO.: 10713 PARCEL NO.: 5302001097
 LOT 95, THE MEADOWS FILING NO. 2
 ZONE: RR-5 PLAT NO.: 10713 PARCEL NO.: 5302001098
 LOT 96, THE MEADOWS FILING NO. 2
 ZONE: RR-5 PLAT NO.: 10713 PARCEL NO.: 5302001099
 LOT 97, THE MEADOWS FILING NO. 2
 ZONE: RR-5 PLAT NO.: 10713 PARCEL NO.: 5302001100
 LOT 98, THE MEADOWS FILING NO. 2
 ZONE: RR-5 PLAT NO.: 10713 PARCEL NO.: 5302001101
 LOT 99, THE MEADOWS FILING NO. 2
 ZONE: RR-5 PLAT NO.: 10713 PARCEL NO.: 5302001102
 LOT 100, THE MEADOWS FILING NO. 2
 ZONE: RR-5 PLAT NO.: 10713 PARCEL NO.: 5302001103
 LOT 101, THE MEADOWS FILING NO. 2
 ZONE: RR-5 PLAT NO.: 10713 PARCEL NO.: 5302001104
 LOT 102, THE MEADOWS FILING NO. 2
 ZONE: RR-5 PLAT NO.: 10713 PARCEL NO.: 5302001105
 LOT 103, THE MEADOWS FILING NO. 2
 ZONE: RR-5 PLAT NO.: 10713 PARCEL NO.: 5302001106
 LOT 104, THE MEADOWS FILING NO. 2
 ZONE: RR-5 PLAT NO.: 10713 PARCEL NO.: 5302001107
 LOT 105, THE MEADOWS FILING NO. 2
 ZONE: RR-5 PLAT NO.: 10713 PARCEL NO.: 5302001108
 LOT 106, THE MEADOWS FILING NO. 2
 ZONE: RR-5 PLAT NO.: 10713 PARCEL NO.: 5302001109
 LOT 107, THE MEADOWS FILING NO. 2
 ZONE: RR-5 PLAT NO.: 10713 PARCEL NO.: 5302001110
 LOT 108, THE MEADOWS FILING NO. 2
 ZONE: RR-5 PLAT NO.: 10713 PARCEL NO.: 5302001111
 LOT 109, THE MEADOWS FILING NO. 2
 ZONE: RR-5 PLAT NO.: 10713 PARCEL NO.: 5302001112
 LOT 110, THE MEADOWS FILING NO. 2
 ZONE: RR-5 PLAT NO.: 10713 PARCEL NO.: 5302001113
 LOT 111, THE MEADOWS FILING NO. 2
 ZONE: RR-5 PLAT NO.: 10713 PARCEL NO.: 5302001114
 LOT 112, THE MEADOWS FILING NO. 2
 ZONE: RR-5 PLAT NO.: 10713 PARCEL NO.: 5302001115
 LOT 113, THE MEADOWS FILING NO. 2
 ZONE: RR-5 PLAT NO.: 10713 PARCEL NO.: 5302001116

WARRANTY DEED RECEPTION NO. 21303554 OWNER: FALCON STORAGE PARTNERS, LLLP
 DEYOYUNG RANDALL L ZONE: I-2 PLAT NO.: 208053974 PARCEL NO.: 5301000016
 LOT 1, LATIGO BUSINESS CENTER FILING NO. 1 ZONE: I-2 PLAT NO.: 12007 PARCEL NO.: 5301000005

SC-6

Inlet Protection (IP)

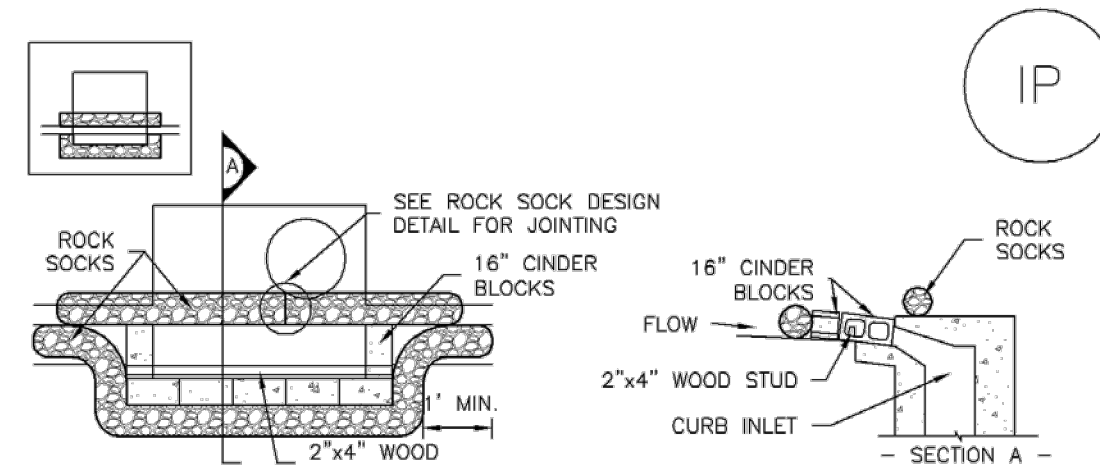

IP-1. BLOCK AND ROCK SOCK SUMP OR ON GRADE INLET PROTECTION

BLOCK AND CURB SOCK INLET PROTECTION INSTALLATION NOTES

- 1. SEE ROCK SOCK DESIGN DETAIL FOR INSTALLATION REQUIREMENTS.
2. CONCRETE "CINDER" BLOCKS SHALL BE LAID ON THEIR SIDES AROUND THE INLET IN A SINGLE ROW, ABUTTING ONE ANOTHER WITH THE OPEN END FACING AWAY FROM THE CURB.
3. GRAVEL BAGS SHALL BE PLACED AROUND CONCRETE BLOCKS, CLOSELY ABUTTING ONE ANOTHER AND JOINTED TOGETHER IN ACCORDANCE WITH ROCK SOCK DESIGN DETAIL.

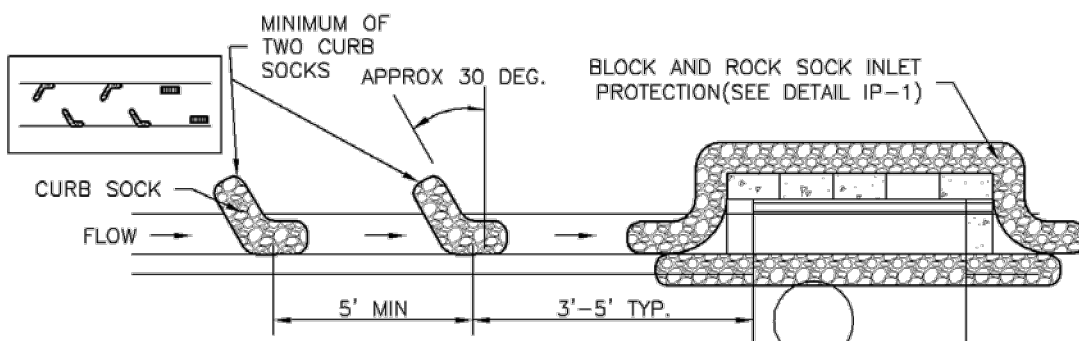

IP-2. CURB ROCK SOCKS UPSTREAM OF INLET PROTECTION

CURB ROCK SOCK INLET PROTECTION INSTALLATION NOTES

- 1. SEE ROCK SOCK DESIGN DETAIL INSTALLATION REQUIREMENTS.
2. PLACEMENT OF THE SOCK SHALL BE APPROXIMATELY 30 DEGREES FROM PERPENDICULAR IN THE OPPOSITE DIRECTION OF FLOW.
3. SOCKS ARE TO BE FLUSH WITH THE CURB AND SPACED A MINIMUM OF 5 FEET APART.
4. AT LEAST TWO CURB SOCKS IN SERIES ARE REQUIRED UPSTREAM OF ON-GRADE INLETS.

IP-4 Urban Drainage and Flood Control District August 2013
Urban Storm Drainage Criteria Manual Volume 3

Inlet Protection (IP)

SC-6

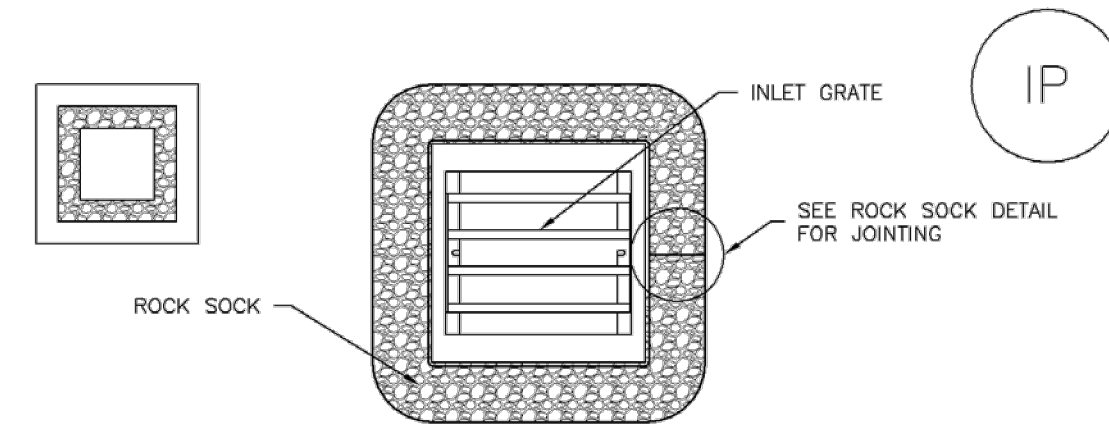

IP-3. ROCK SOCK SUMP/AREA INLET PROTECTION

ROCK SOCK SUMP/AREA INLET PROTECTION INSTALLATION NOTES

- 1. SEE ROCK SOCK DESIGN DETAIL FOR INSTALLATION REQUIREMENTS.
2. STRAW WATTLES/SEDIMENT CONTROL LOGS MAY BE USED IN PLACE OF ROCK SOCKS FOR INLETS IN PERVIOUS AREAS. INSTALL PER SEDIMENT CONTROL LOG DETAIL.

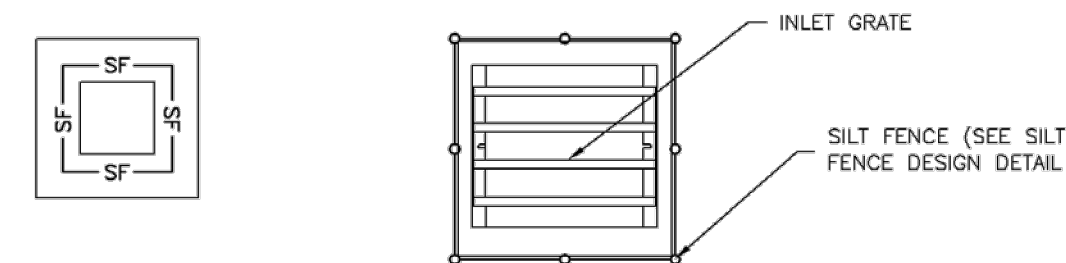

IP-4. SILT FENCE FOR SUMP INLET PROTECTION

SILT FENCE INLET PROTECTION INSTALLATION NOTES

- 1. SEE SILT FENCE DESIGN DETAIL FOR INSTALLATION REQUIREMENTS.
2. POSTS SHALL BE PLACED AT EACH CORNER OF THE INLET AND AROUND THE EDGES AT A MAXIMUM SPACING OF 3 FEET.
3. STRAW WATTLES/SEDIMENT CONTROL LOGS MAY BE USED IN PLACE OF SILT FENCE FOR INLETS IN PERVIOUS AREAS. INSTALL PER SEDIMENT CONTROL LOG DETAIL.

August 2013 Urban Drainage and Flood Control District August 2013
Urban Storm Drainage Criteria Manual Volume 3

SC-6

Inlet Protection (IP)

GENERAL INLET PROTECTION INSTALLATION NOTES

- 1. SEE PLAN VIEW FOR:
- LOCATION OF INLET PROTECTION.
- TYPE OF INLET PROTECTION (IP.1, IP.2, IP.3, IP.4, IP.5, IP.6)
2. INLET PROTECTION SHALL BE INSTALLED PROMPTLY AFTER INLET CONSTRUCTION OR PAVING IS COMPLETE, (TYPICALLY WITHIN 48 HOURS). IF A RAINFALL/RUNOFF EVENT IS FORECAST, INSTALL INLET PROTECTION PRIOR TO ONSET OF EVENT.

INLET PROTECTION MAINTENANCE NOTES

- 1. INSPECT BMPs EACH WORKDAY, AND MAINTAIN THEM IN EFFECTIVE OPERATING CONDITION. MAINTENANCE OF BMPs SHOULD BE PROACTIVE, NOT REACTIVE. INSPECT BMPs AS SOON AS POSSIBLE (AND ALWAYS WITHIN 24 HOURS) FOLLOWING A STORM THAT CAUSES SURFACE EROSION, AND PERFORM NECESSARY MAINTENANCE.
2. FREQUENT OBSERVATIONS AND MAINTENANCE ARE NECESSARY TO MAINTAIN BMPs IN EFFECTIVE OPERATING CONDITION. INSPECTIONS AND CORRECTIVE MEASURES SHOULD BE DOCUMENTED THOROUGHLY.
3. WHERE BMPs HAVE FAILED, REPAIR OR REPLACEMENT SHOULD BE INITIATED UPON DISCOVERY OF THE FAILURE.
4. SEDIMENT ACCUMULATED UPSTREAM OF INLET PROTECTION SHALL BE REMOVED AS NECESSARY TO MAINTAIN BMP EFFECTIVENESS, TYPICALLY WHEN STORAGE VOLUME REACHES 50% OF CAPACITY, A DEPTH OF 6" WHEN SILT FENCE IS USED, OR 1/4 OF THE HEIGHT FOR STRAW BALES.
5. INLET PROTECTION IS TO REMAIN IN PLACE UNTIL THE UPSTREAM DISTURBED AREA IS PERMANENTLY STABILIZED, UNLESS THE LOCAL JURISDICTION APPROVES EARLIER REMOVAL OF INLET PROTECTION IN STREETS.
6. WHEN INLET PROTECTION AT AREA INLETS IS REMOVED, THE DISTURBED AREA SHALL BE COVERED WITH TOP SOIL, SEEDED AND MULCHED, OR OTHERWISE STABILIZED IN A MANNER APPROVED BY THE LOCAL JURISDICTION.

(DETAIL ADAPTED FROM TOWN OF PARKER, COLORADO AND CITY OF AURORA, COLORADO, NOT AVAILABLE IN AUTOCAD)

NOTE: MANY JURISDICTIONS HAVE BMP DETAILS THAT VARY FROM UDFCD STANDARD DETAILS. CONSULT WITH LOCAL JURISDICTIONS AS TO WHICH DETAIL SHOULD BE USED WHEN DIFFERENCES ARE NOTED.

NOTE: THE DETAILS INCLUDED WITH THIS FACT SHEET SHOW COMMONLY USED, CONVENTIONAL METHODS OF INLET PROTECTION IN THE DENVER METROPOLITAN AREA. THERE ARE MANY PROPRIETARY INLET PROTECTION METHODS ON THE MARKET. UDFCD NEITHER ENDORSES NOR DISCOURAGES USE OF PROPRIETARY INLET PROTECTION; HOWEVER, IN THE EVENT PROPRIETARY METHODS ARE USED, THE APPROPRIATE DETAIL FROM THE MANUFACTURER MUST BE INCLUDED IN THE SWMP AND THE BMP MUST BE INSTALLED AND MAINTAINED AS SHOWN IN THE MANUFACTURER'S DETAILS.

NOTE: SOME MUNICIPALITIES DISCOURAGE OR PROHIBIT THE USE OF STRAW BALES FOR INLET PROTECTION. CHECK WITH LOCAL JURISDICTION TO DETERMINE IF STRAW BALE INLET PROTECTION IS ACCEPTABLE.

IP-8 Urban Drainage and Flood Control District August 2013
Urban Storm Drainage Criteria Manual Volume 3

Sediment Basin (SB)

SC-7

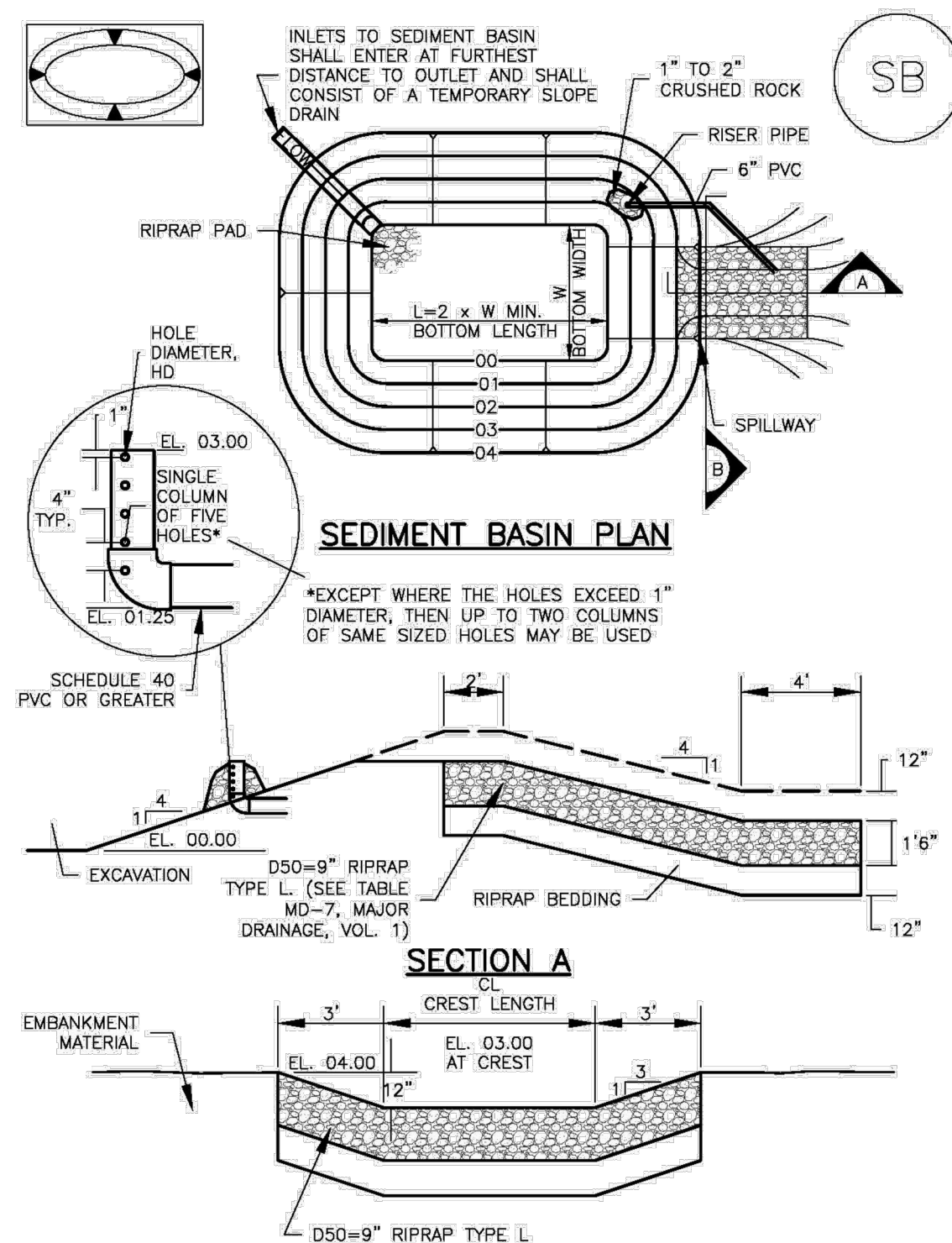

August 2013 Urban Drainage and Flood Control District August 2013
Urban Storm Drainage Criteria Manual Volume 3

SC-7

Sediment Basin (SB)

Table SB-1. SIZING INFORMATION FOR STANDARD SEDIMENT BASIN. Columns: Upstream Drainage Area (ac), Basin Bottom Width (ft), Spillway Crest Length (ft), Hole Diameter (in).

SEDIMENT BASIN INSTALLATION NOTES

- 1. SEE PLAN VIEW FOR:
- LOCATION OF SEDIMENT BASIN.
- TYPE OF BASIN (STANDARD BASIN OR NONSTANDARD BASIN).
- FOR STANDARD BASIN, BOTTOM WIDTH W, CREST LENGTH CL, AND HOLE DIAMETER, HD.
- FOR NONSTANDARD BASIN, SEE CONSTRUCTION DRAWINGS FOR DESIGN OF BASIN INCLUDING RISER HEIGHT H, NUMBER OF COLUMNS N, HOLE DIAMETER HD AND PIPE DIAMETER D.
2. FOR STANDARD BASIN, BOTTOM DIMENSION MAY BE MODIFIED AS LONG AS BOTTOM AREA IS NOT REDUCED.
3. SEDIMENT BASINS SHALL BE INSTALLED PRIOR TO ANY OTHER LAND-DISTURBING ACTIVITY THAT RELIES ON ON BASINS AS A STORMWATER CONTROL.
4. EMBANKMENT MATERIAL SHALL CONSIST OF SOIL FREE OF DEBRIS, ORGANIC MATERIAL, AND ROCKS OR CONCRETE GREATER THAN 3 INCHES AND SHALL HAVE A MINIMUM OF 15 PERCENT BY WEIGHT PASSING THE NO. 200 SIEVE.
5. EMBANKMENT MATERIAL SHALL BE COMPACTED TO AT LEAST 95 PERCENT OF MAXIMUM DENSITY IN ACCORDANCE WITH ASTM D698.
6. PIPE SCH 40 OR GREATER SHALL BE USED.
7. THE DETAILS SHOWN ON THESE SHEETS PERTAIN TO STANDARD SEDIMENT BASIN(S) FOR DRAINAGE AREAS LESS THAN 15 ACRES. SEE CONSTRUCTION DRAWINGS FOR EMBANKMENT, STORAGE VOLUME, SPILLWAY, OUTLET, AND OUTLET PROTECTION DETAILS FOR ANY SEDIMENT BASIN(S) THAT HAVE BEEN INDIVIDUALLY DESIGNED FOR DRAINAGE AREAS LARGER THAN 15 ACRES.

August 2013 Urban Drainage and Flood Control District August 2013
Urban Storm Drainage Criteria Manual Volume 3

Sediment Basin (SB)

SC-7

SEDIMENT BASIN MAINTENANCE NOTES

- 1. INSPECT BMPs EACH WORKDAY, AND MAINTAIN THEM IN EFFECTIVE OPERATING CONDITION. MAINTENANCE OF BMPs SHOULD BE PROACTIVE, NOT REACTIVE. INSPECT BMPs AS SOON AS POSSIBLE (AND ALWAYS WITHIN 24 HOURS) FOLLOWING A STORM THAT CAUSES SURFACE EROSION, AND PERFORM NECESSARY MAINTENANCE.
2. FREQUENT OBSERVATIONS AND MAINTENANCE ARE NECESSARY TO MAINTAIN BMPs IN EFFECTIVE OPERATING CONDITION. INSPECTIONS AND CORRECTIVE MEASURES SHOULD BE DOCUMENTED THOROUGHLY.
3. WHERE BMPs HAVE FAILED, REPAIR OR REPLACEMENT SHOULD BE INITIATED UPON DISCOVERY OF THE FAILURE.
4. SEDIMENT ACCUMULATED IN BASIN SHALL BE REMOVED AS NEEDED TO MAINTAIN BMP EFFECTIVENESS, TYPICALLY WHEN SEDIMENT DEPTH REACHES ONE FOOT (I.E., TWO FEET BELOW THE SPILLWAY CREST).
5. SEDIMENT BASINS ARE TO REMAIN IN PLACE UNTIL THE UPSTREAM DISTURBED AREA IS STABILIZED AND GRASS COVER IS ACCEPTED BY THE LOCAL JURISDICTION.
6. WHEN SEDIMENT BASINS ARE REMOVED, ALL DISTURBED AREAS SHALL BE COVERED WITH TOPSOIL, SEEDED AND MULCHED OR OTHERWISE STABILIZED AS APPROVED BY LOCAL JURISDICTION.

(DETAILS ADAPTED FROM DOUGLAS COUNTY, COLORADO)

NOTE: MANY JURISDICTIONS HAVE BMP DETAILS THAT VARY FROM UDFCD STANDARD DETAILS. CONSULT WITH LOCAL JURISDICTIONS AS TO WHICH DETAIL SHOULD BE USED WHEN DIFFERENCES ARE NOTED.

August 2013 Urban Drainage and Flood Control District August 2013
Urban Storm Drainage Criteria Manual Volume 3

Table with 4 columns: #, Date, Issue / Description, Init. It contains a list of revision entries.

Project No: CLH000021
Drawn By: CMWJ
Checked By: RGD
Date: 05/XX/2021

GEC DETAILS

COPYRIGHT
 THESE PLANS ARE AN INSTRUMENT OF SERVICE AND ARE THE PROPERTY OF GALLOWAY, AND MAY NOT BE DUPLICATED, DISCLOSED, OR REPRODUCED WITHOUT THE WRITTEN CONSENT OF GALLOWAY. COPYRIGHTS AND INFRINGEMENTS WILL BE ENFORCED AND PROSECUTED.

**CHALLENGER
 HOMES**

CONSTRUCTION DOCUMENTS
 FALCON MEADOWS AT BENT GRASS FILING NO. 4
 FOR
 CHALLENGER COMMUNITIES, LLC

BENT GRASS MEADOWS DRIVE & MERIDIAN ROAD
 FALCON, CO 80831 - EL PASO COUNTY

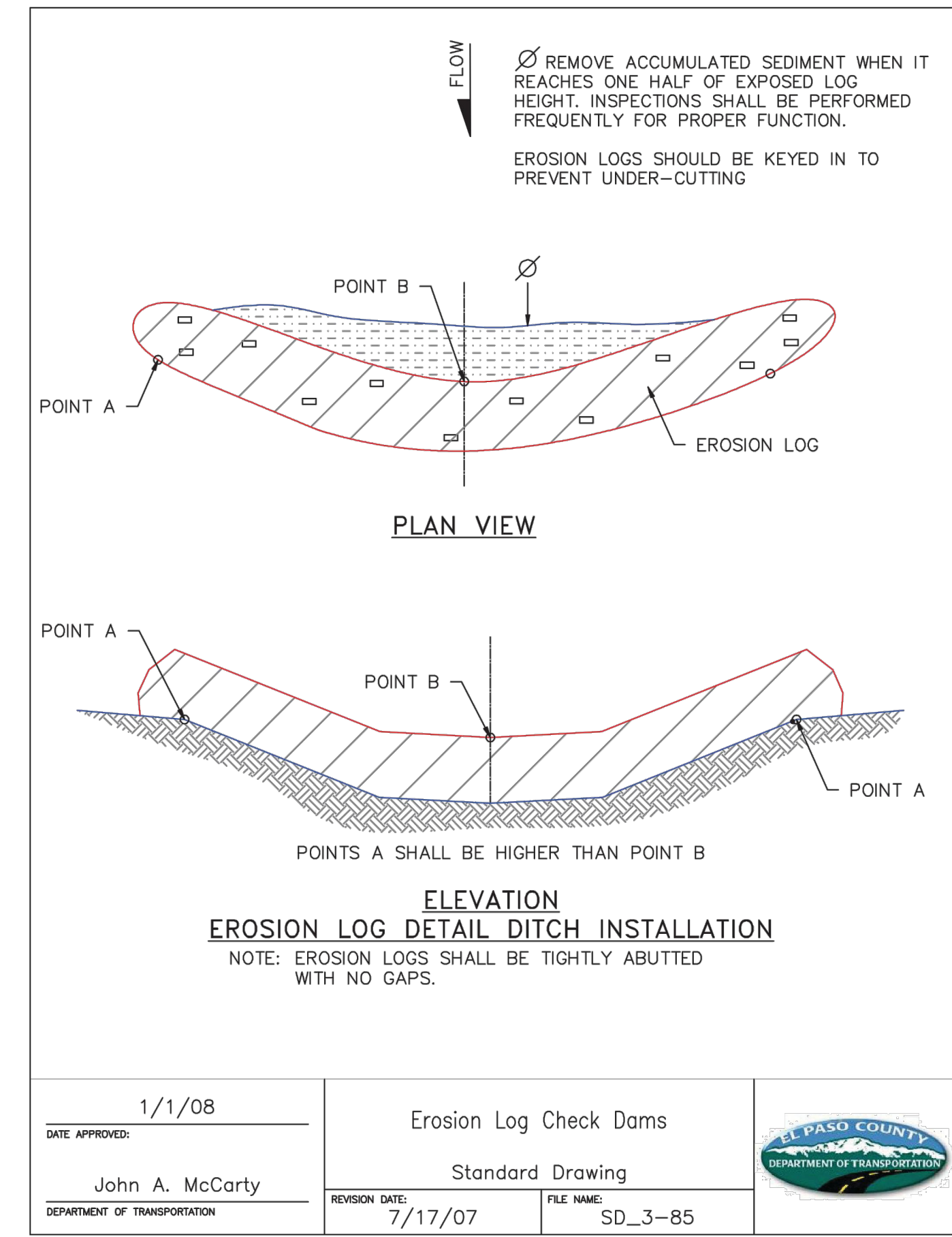
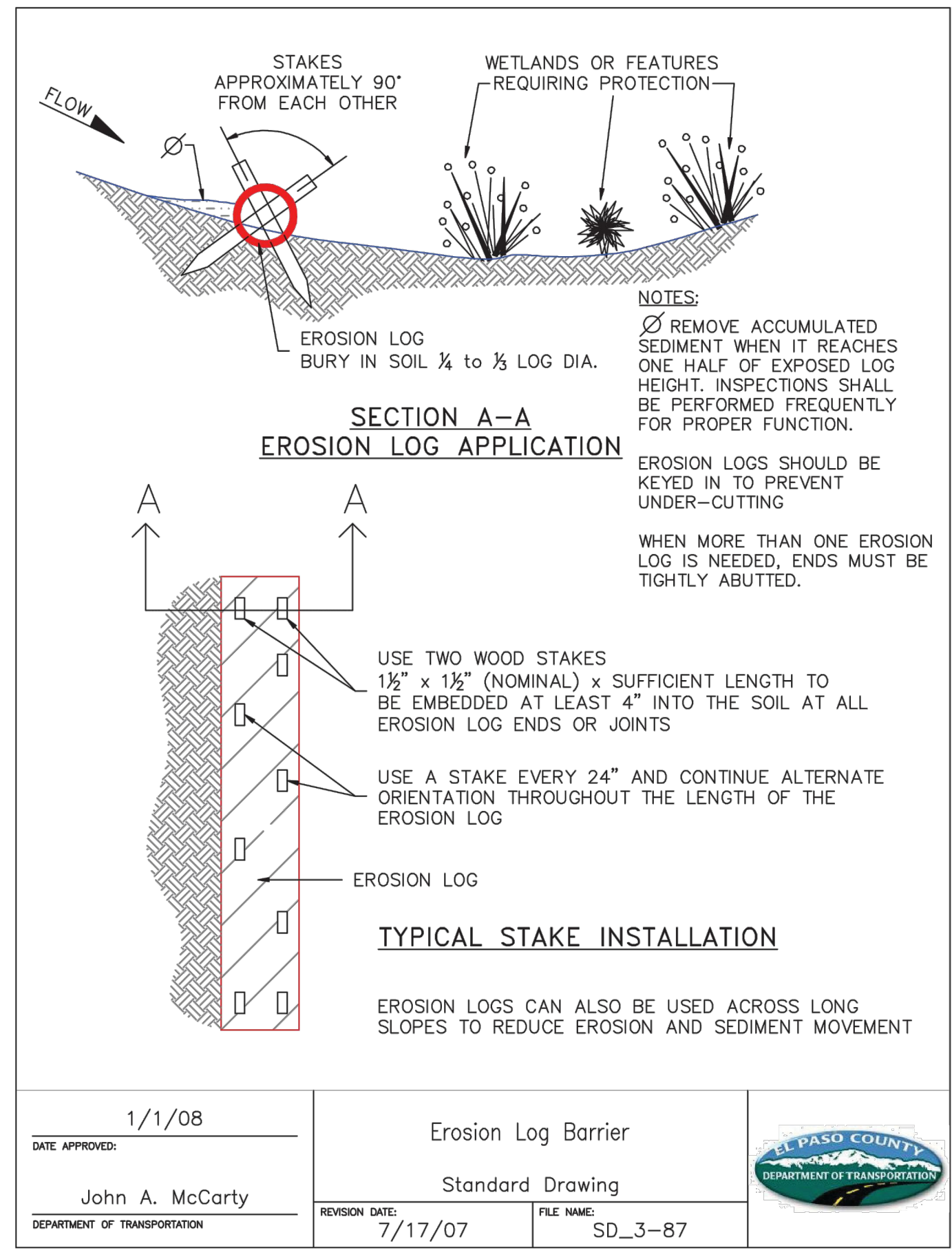
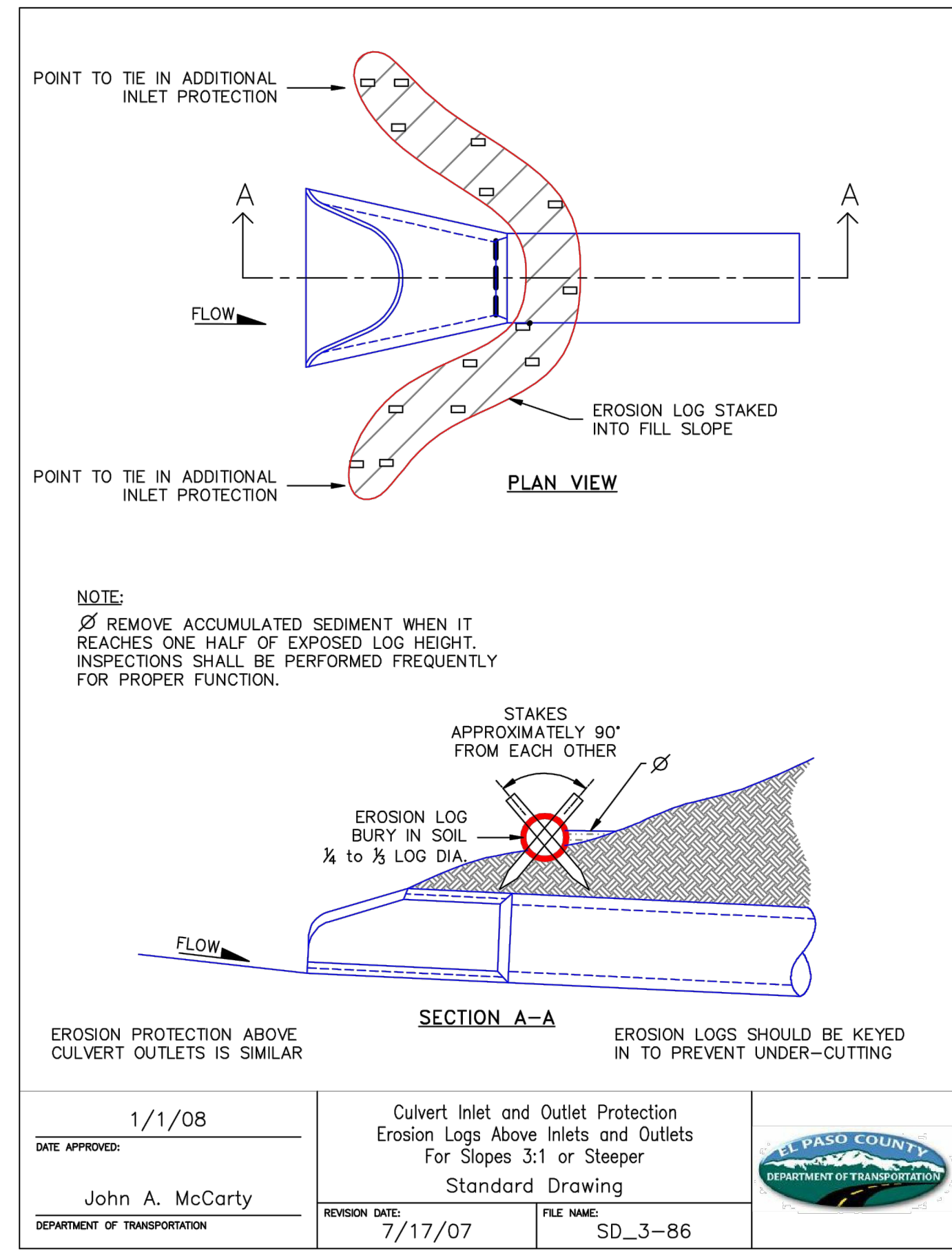

#	Date	Issue / Description	Init.

Project No: CLH000021
 Drawn By: CMWJ
 Checked By: RGD
 Date: 05/XX/2021

GEC DETAILS

C:\CHANGE\HOME\HCS2\Plan: 03/08/07: P:\Bent Grass Meadows\03/08/07\02_25_GEC_Details.dwg: 25: GEC_Details: 10/20/07: 10/20/07

APPENDIX E

Seeding dates for the highest success probability of perennial species along the Front Range are generally in the spring from April through early May and in the fall after the first of September until the ground freezes. If the area is irrigated, seeding may occur in summer months, as well. See Table TS/PS-3 for appropriate seeding dates.

Table TS/PS-1. Minimum Drill Seeding Rates for Various Temporary Annual Grasses

Species ^a (Common name)	Growth Season ^b	Pounds of Pure Live Seed (PLS)/acre ^c	Planting Depth (inches)
1. Oats	Cool	35 - 50	1 - 2
2. Spring wheat	Cool	25 - 35	1 - 2
3. Spring barley	Cool	25 - 35	1 - 2
4. Annual ryegrass	Cool	10 - 15	½
5. Millet	Warm	3 - 15	½ - ¾
6. Sudangrass	Warm	5-10	½ - ¾
7. Sorghum	Warm	5-10	½ - ¾
8. Winter wheat	Cool	20-35	1 - 2
9. Winter barley	Cool	20-35	1 - 2
10. Winter rye	Cool	20-35	1 - 2
11. Triticale	Cool	25-40	1 - 2

^a Successful seeding of annual grass resulting in adequate plant growth will usually produce enough dead-plant residue to provide protection from wind and water erosion for an additional year. This assumes that the cover is not disturbed or mowed closer than 8 inches.

Hydraulic seeding may be substituted for drilling only where slopes are steeper than 3:1 or where access limitations exist. When hydraulic seeding is used, hydraulic mulching should be applied as a separate operation, when practical, to prevent the seeds from being encapsulated in the mulch.

^b See Table TS/PS-3 for seeding dates. Irrigation, if consistently applied, may extend the use of cool season species during the summer months.

^c Seeding rates should be doubled if seed is broadcast, or increased by 50 percent if done using a Brillion Drill or by hydraulic seeding.

EC-2 Temporary and Permanent Seeding (TS/PS)

Table TS/PS-2. Minimum Drill Seeding Rates for Perennial Grasses

Common ^a Name	Botanical Name	Growth Season ^b	Growth Form	Seeds/ Pound	Pounds of PLS/acre
Alakali Soil Seed Mix					
Alkali sacaton	<i>Sporobolus airoides</i>	Cool	Bunch	1,750,000	0.25
Basin wildrye	<i>Elymus cinereus</i>	Cool	Bunch	165,000	2.5
Sodar streambank wheatgrass	<i>Agropyron riparium 'Sodar'</i>	Cool	Sod	170,000	2.5
Jose tall wheatgrass	<i>Agropyron elongatum 'Jose'</i>	Cool	Bunch	79,000	7.0
Arriba western wheatgrass	<i>Agropyron smithii 'Arriba'</i>	Cool	Sod	110,000	5.5
Total					17.75
Fertile Loamy Soil Seed Mix					
Ephriam crested wheatgrass	<i>Agropyron cristatum 'Ephriam'</i>	Cool	Sod	175,000	2.0
Dural hard fescue	<i>Festuca ovina 'duriuscula'</i>	Cool	Bunch	565,000	1.0
Lincoln smooth brome	<i>Bromus inermis leys 'Lincoln'</i>	Cool	Sod	130,000	3.0
Sodar streambank wheatgrass	<i>Agropyron riparium 'Sodar'</i>	Cool	Sod	170,000	2.5
Arriba western wheatgrass	<i>Agropyron smithii 'Arriba'</i>	Cool	Sod	110,000	7.0
Total					15.5
High Water Table Soil Seed Mix					
Meadow foxtail	<i>Alopecurus pratensis</i>	Cool	Sod	900,000	0.5
Redtop	<i>Agrostis alba</i>	Warm	Open sod	5,000,000	0.25
Reed canarygrass	<i>Phalaris arundinacea</i>	Cool	Sod	68,000	0.5
Lincoln smooth brome	<i>Bromus inermis leys 'Lincoln'</i>	Cool	Sod	130,000	3.0
Pathfinder switchgrass	<i>Panicum virgatum 'Pathfinder'</i>	Warm	Sod	389,000	1.0
Alkar tall wheatgrass	<i>Agropyron elongatum 'Alkar'</i>	Cool	Bunch	79,000	5.5
Total					10.75
Transition Turf Seed Mix^c					
Ruebens Canadian bluegrass	<i>Poa compressa 'Ruebens'</i>	Cool	Sod	2,500,000	0.5
Dural hard fescue	<i>Festuca ovina 'duriuscula'</i>	Cool	Bunch	565,000	1.0
Citation perennial ryegrass	<i>Lolium perenne 'Citation'</i>	Cool	Sod	247,000	3.0
Lincoln smooth brome	<i>Bromus inermis leys 'Lincoln'</i>	Cool	Sod	130,000	3.0
Total					7.5

Table TS/PS-2. Minimum Drill Seeding Rates for Perennial Grasses (cont.)

Common Name	Botanical Name	Growth Season ^b	Growth Form	Seeds/Pound	Pounds of PLS/acre
Sandy Soil Seed Mix					
Blue grama	<i>Bouteloua gracilis</i>	Warm	Sod-forming bunchgrass	825,000	0.5
Camper little bluestem	<i>Schizachyrium scoparium</i> 'Camper'	Warm	Bunch	240,000	1.0
Prairie sandreed	<i>Calamovilfa longifolia</i>	Warm	Open sod	274,000	1.0
Sand dropseed	<i>Sporobolus cryptandrus</i>	Cool	Bunch	5,298,000	0.25
Vaughn sideoats grama	<i>Bouteloua curtipendula</i> 'Vaughn'	Warm	Sod	191,000	2.0
Arriba western wheatgrass	<i>Agropyron smithii</i> 'Arriba'	Cool	Sod	110,000	5.5
Total					10.25
Heavy Clay, Rocky Foothill Seed Mix					
Ephriam crested wheatgrass ^d	<i>Agropyron cristatum</i> 'Ephriam'	Cool	Sod	175,000	1.5
Oahe Intermediate wheatgrass	<i>Agropyron intermedium</i> 'Oahe'	Cool	Sod	115,000	5.5
Vaughn sideoats grama ^e	<i>Bouteloua curtipendula</i> 'Vaughn'	Warm	Sod	191,000	2.0
Lincoln smooth brome	<i>Bromus inermis</i> leys 'Lincoln'	Cool	Sod	130,000	3.0
Arriba western wheatgrass	<i>Agropyron smithii</i> 'Arriba'	Cool	Sod	110,000	5.5
Total					17.5
<p>^a All of the above seeding mixes and rates are based on drill seeding followed by crimped straw mulch. These rates should be doubled if seed is broadcast and should be increased by 50 percent if the seeding is done using a Brillion Drill or is applied through hydraulic seeding. Hydraulic seeding may be substituted for drilling only where slopes are steeper than 3:1. If hydraulic seeding is used, hydraulic mulching should be done as a separate operation.</p> <p>^b See Table TS/PS-3 for seeding dates.</p> <p>^c If site is to be irrigated, the transition turf seed rates should be doubled.</p> <p>^d Crested wheatgrass should not be used on slopes steeper than 6H to 1V.</p> <p>^e Can substitute 0.5 lbs PLS of blue grama for the 2.0 lbs PLS of Vaughn sideoats grama.</p>					

EC-2 Temporary and Permanent Seeding (TS/PS)

Table TS/PS-3. Seeding Dates for Annual and Perennial Grasses

Seeding Dates	Annual Grasses (Numbers in table reference species in Table TS/PS-1)		Perennial Grasses	
	Warm	Cool	Warm	Cool
January 1–March 15			✓	✓
March 16–April 30	4	1,2,3	✓	✓
May 1–May 15	4		✓	
May 16–June 30	4,5,6,7			
July 1–July 15	5,6,7			
July 16–August 31				
September 1–September 30		8,9,10,11		
October 1–December 31			✓	✓

Mulch

Cover seeded areas with mulch or an appropriate rolled erosion control product to promote establishment of vegetation. Anchor mulch by crimping, netting or use of a non-toxic tackifier. See the Mulching BMP Fact Sheet for additional guidance.

Maintenance and Removal

Monitor and observe seeded areas to identify areas of poor growth or areas that fail to germinate. Reseed and mulch these areas, as needed.

An area that has been permanently seeded should have a good stand of vegetation within one growing season if irrigated and within three growing seasons without irrigation in Colorado. Reseed portions of the site that fail to germinate or remain bare after the first growing season.

Seeded areas may require irrigation, particularly during extended dry periods. Targeted weed control may also be necessary.

Protect seeded areas from construction equipment and vehicle access.

- Clean, weed-free and seed-free cereal grain straw should be applied evenly at a rate of 2 tons per acre and must be tacked or fastened by a method suitable for the condition of the site. Straw mulch must be anchored (and not merely placed) on the surface. This can be accomplished mechanically by crimping or with the aid of tackifiers or nets. Anchoring with a crimping implement is preferred, and is the recommended method for areas flatter than 3:1. Mechanical crimpers must be capable of tucking the long mulch fibers into the soil to a depth of 3 inches without cutting them. An agricultural disk, while not an ideal substitute, may work if the disk blades are dull or blunted and set vertically; however, the frame may have to be weighted to afford proper soil penetration.
- Grass hay may be used in place of straw; however, because hay is comprised of the entire plant including seed, mulching with hay may seed the site with non-native grass species which might in turn out-compete the native seed. Alternatively, native species of grass hay may be purchased, but can be difficult to find and are more expensive than straw. Purchasing and utilizing a certified weed-free straw is an easier and less costly mulching method. When using grass hay, follow the same guidelines as for straw (provided above).
- On small areas sheltered from the wind and heavy runoff, spraying a tackifier on the mulch is satisfactory for holding it in place. For steep slopes and special situations where greater control is needed, erosion control blankets anchored with stakes should be used instead of mulch.
- Hydraulic mulching consists of wood cellulose fibers mixed with water and a tackifying agent and should be applied at a rate of no less than 1,500 pounds per acre (1,425 lbs of fibers mixed with at least 75 lbs of tackifier) with a hydraulic mulcher. For steeper slopes, up to 2000 pounds per acre may be required for effective hydroseeding. Hydromulch typically requires up to 24 hours to dry; therefore, it should not be applied immediately prior to inclement weather. Application to roads, waterways and existing vegetation should be avoided.
- Erosion control mats, blankets, or nets are recommended to help stabilize steep slopes (generally 3:1 and steeper) and waterways. Depending on the product, these may be used alone or in conjunction with grass or straw mulch. Normally, use of these products will be restricted to relatively small areas. Biodegradable mats made of straw and jute, straw-coconut, coconut fiber, or excelsior can be used instead of mulch. (See the ECM/TRM BMP for more information.)
- Some tackifiers or binders may be used to anchor mulch. Check with the local jurisdiction for allowed tackifiers. Manufacturer's recommendations should be followed at all times. (See the Soil Binder BMP for more information on general types of tackifiers.)
- Rock can also be used as mulch. It provides protection of exposed soils to wind and water erosion and allows infiltration of precipitation. An aggregate base course can be spread on disturbed areas for temporary or permanent stabilization. The rock mulch layer should be thick enough to provide full coverage of exposed soil on the area it is applied.

Maintenance and Removal

After mulching, the bare ground surface should not be more than 10 percent exposed. Reapply mulch, as needed, to cover bare areas.

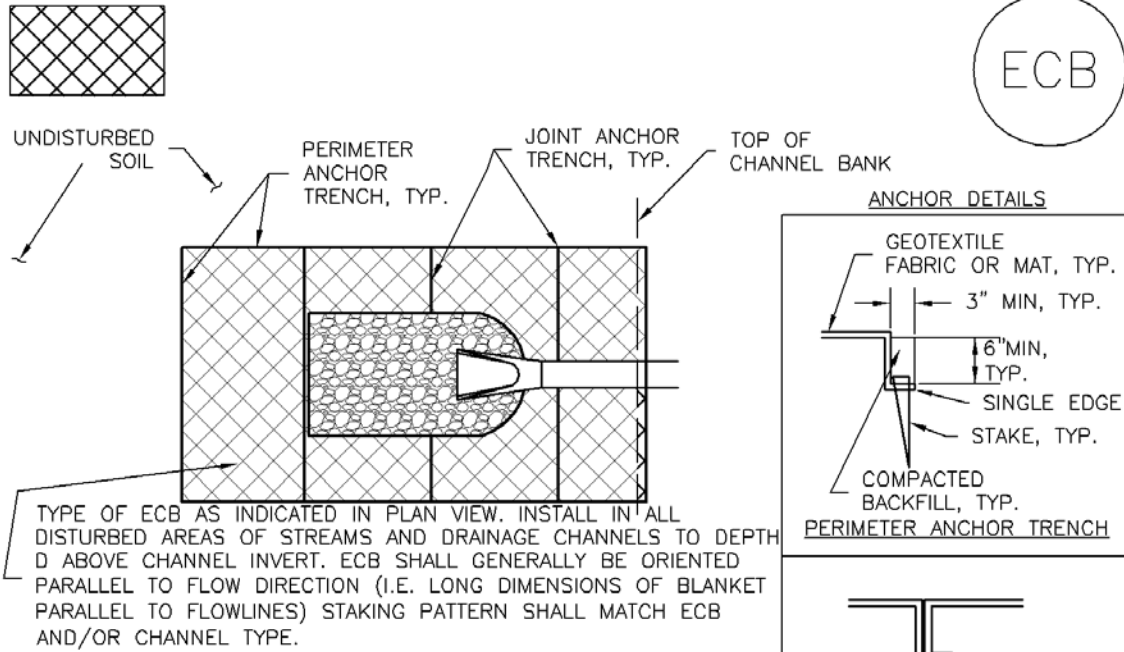

ECB-1. PIPE OUTLET TO DRAINAGEWAY

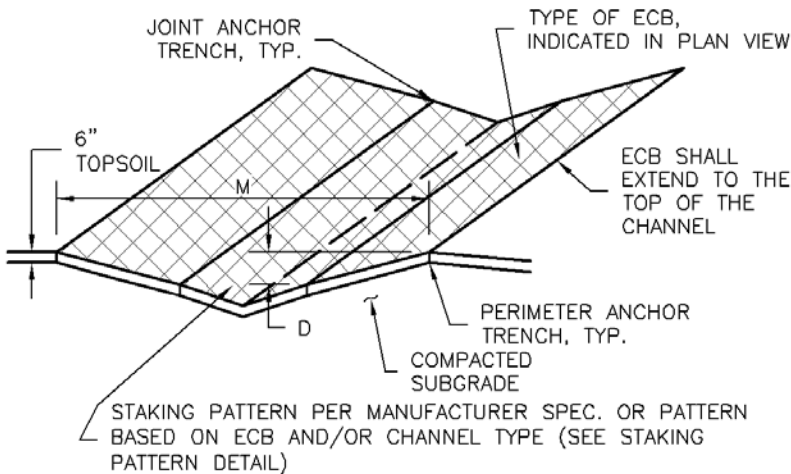

ECB-2. SMALL DITCH OR DRAINAGEWAY

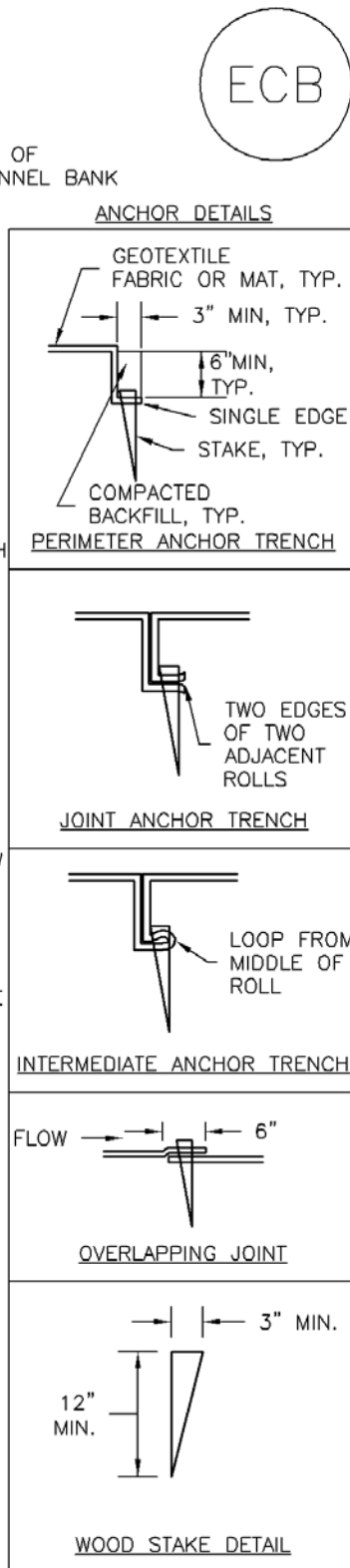

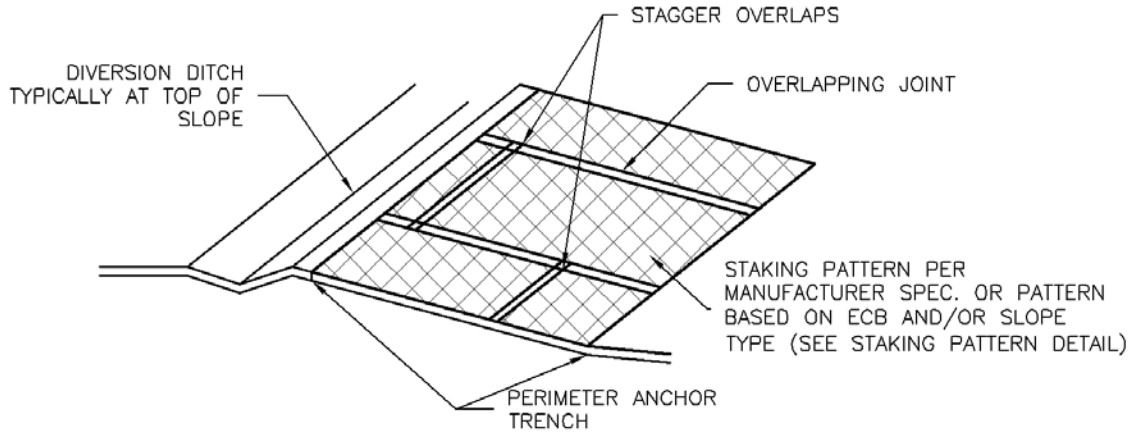

ECB-3. OUTSIDE OF DRAINAGEWAY

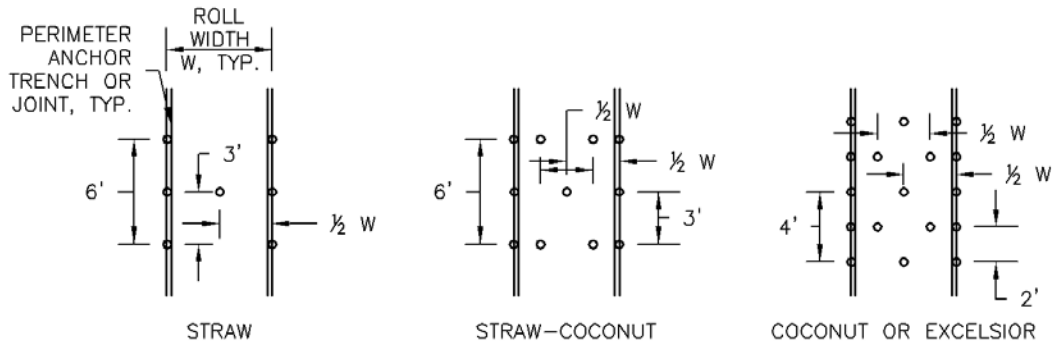

STAKING PATTERNS BY ECB TYPE

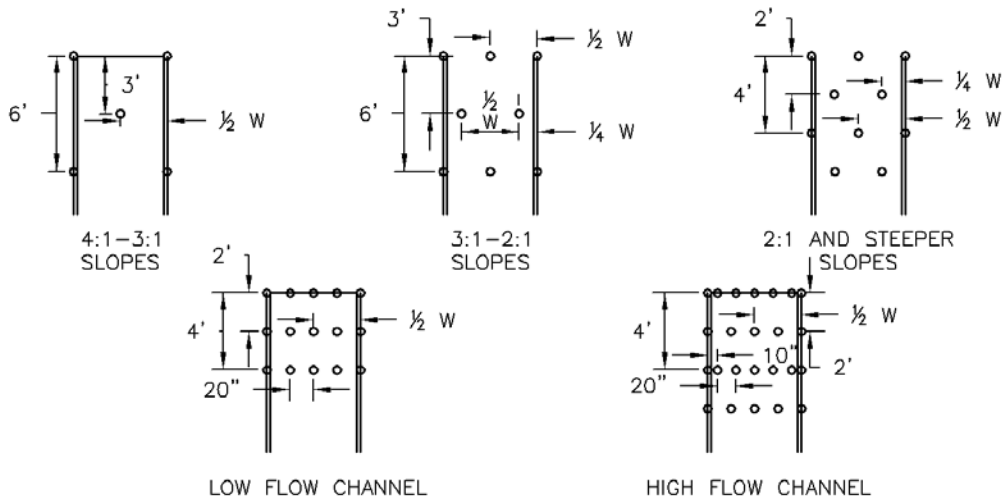

STAKING PATTERNS BY SLOPE OR CHANNEL TYPE

EROSION CONTROL BLANKET INSTALLATION NOTES

1. SEE PLAN VIEW FOR:
 - LOCATION OF ECB.
 - TYPE OF ECB (STRAW, STRAW-COCONUT, COCONUT, OR EXCELSIOR).
 - AREA, A, IN SQUARE YARDS OF EACH TYPE OF ECB.
2. 100% NATURAL AND BIODEGRADABLE MATERIALS ARE PREFERRED FOR RECPs, ALTHOUGH SOME JURISDICTIONS MAY ALLOW OTHER MATERIALS IN SOME APPLICATIONS.
3. IN AREAS WHERE ECBs ARE SHOWN ON THE PLANS, THE PERMITTEE SHALL PLACE TOPSOIL AND PERFORM FINAL GRADING, SURFACE PREPARATION, AND SEEDING AND MULCHING. SUBGRADE SHALL BE SMOOTH AND MOIST PRIOR TO ECB INSTALLATION AND THE ECB SHALL BE IN FULL CONTACT WITH SUBGRADE. NO GAPS OR VOIDS SHALL EXIST UNDER THE BLANKET.
4. PERIMETER ANCHOR TRENCH SHALL BE USED ALONG THE OUTSIDE PERIMETER OF ALL BLANKET AREAS.
5. JOINT ANCHOR TRENCH SHALL BE USED TO JOIN ROLLS OF ECBs TOGETHER (LONGITUDINALLY AND TRANSVERSELY) FOR ALL ECBs EXCEPT STRAW WHICH MAY USE AN OVERLAPPING JOINT.
6. INTERMEDIATE ANCHOR TRENCH SHALL BE USED AT SPACING OF ONE-HALF ROLL LENGTH FOR COCONUT AND EXCELSIOR ECBs.
7. OVERLAPPING JOINT DETAIL SHALL BE USED TO JOIN ROLLS OF ECBs TOGETHER FOR ECBs ON SLOPES.
8. MATERIAL SPECIFICATIONS OF ECBs SHALL CONFORM TO TABLE ECB-1.
9. ANY AREAS OF SEEDING AND MULCHING DISTURBED IN THE PROCESS OF INSTALLING ECBs SHALL BE RESEEDED AND MULCHED.
10. DETAILS ON DESIGN PLANS FOR MAJOR DRAINAGEWAY STABILIZATION WILL GOVERN IF DIFFERENT FROM THOSE SHOWN HERE.

TABLE ECB-1. ECB MATERIAL SPECIFICATIONS				
TYPE	COCONUT CONTENT	STRAW CONTENT	EXCELSIOR CONTENT	RECOMMENDED NETTING**
STRAW*	-	100%	-	DOUBLE/NATURAL
STRAW-COCONUT	30% MIN	70% MAX	-	DOUBLE/NATURAL
COCONUT	100%	-	-	DOUBLE/NATURAL
EXCELSIOR	-	-	100%	DOUBLE/NATURAL

*STRAW ECBs MAY ONLY BE USED OUTSIDE OF STREAMS AND DRAINAGE CHANNEL.
 **ALTERNATE NETTING MAY BE ACCEPTABLE IN SOME JURISDICTIONS

EROSION CONTROL BLANKET MAINTENANCE NOTES

1. INSPECT BMPs EACH WORKDAY, AND MAINTAIN THEM IN EFFECTIVE OPERATING CONDITION. MAINTENANCE OF BMPs SHOULD BE PROACTIVE, NOT REACTIVE. INSPECT BMPs AS SOON AS POSSIBLE (AND ALWAYS WITHIN 24 HOURS) FOLLOWING A STORM THAT CAUSES SURFACE EROSION, AND PERFORM NECESSARY MAINTENANCE.
2. FREQUENT OBSERVATIONS AND MAINTENANCE ARE NECESSARY TO MAINTAIN BMPs IN EFFECTIVE OPERATING CONDITION. INSPECTIONS AND CORRECTIVE MEASURES SHOULD BE DOCUMENTED THOROUGHLY.
3. WHERE BMPs HAVE FAILED, REPAIR OR REPLACEMENT SHOULD BE INITIATED UPON DISCOVERY OF THE FAILURE.
4. ECBs SHALL BE LEFT IN PLACE TO EVENTUALLY BIODEGRADE, UNLESS REQUESTED TO BE REMOVED BY THE LOCAL JURISDICTION.
5. ANY ECB PULLED OUT, TORN, OR OTHERWISE DAMAGED SHALL BE REPAIRED OR REINSTALLED. ANY SUBGRADE AREAS BELOW THE GEOTEXTILE THAT HAVE ERODED TO CREATED A VOID UNDER THE BLANKET, OR THAT REMAIN DEVOID OF GRASS SHALL BE REPAIRED, RESEDED AND MULCHED AND THE ECB REINSTALLED.

NOTE: MANY JURISDICTIONS HAVE BMP DETAILS THAT VARY FROM UDFCD STANDARD DETAILS. CONSULT WITH LOCAL JURISDICTIONS AS TO WHICH DETAIL SHOULD BE USED WHEN DIFFERENCES ARE NOTED.

(DETAILS ADAPTED FROM DOUGLAS COUNTY, COLORADO AND TOWN OF PARKER COLORADO, NOT AVAILABLE IN AUTOCAD)

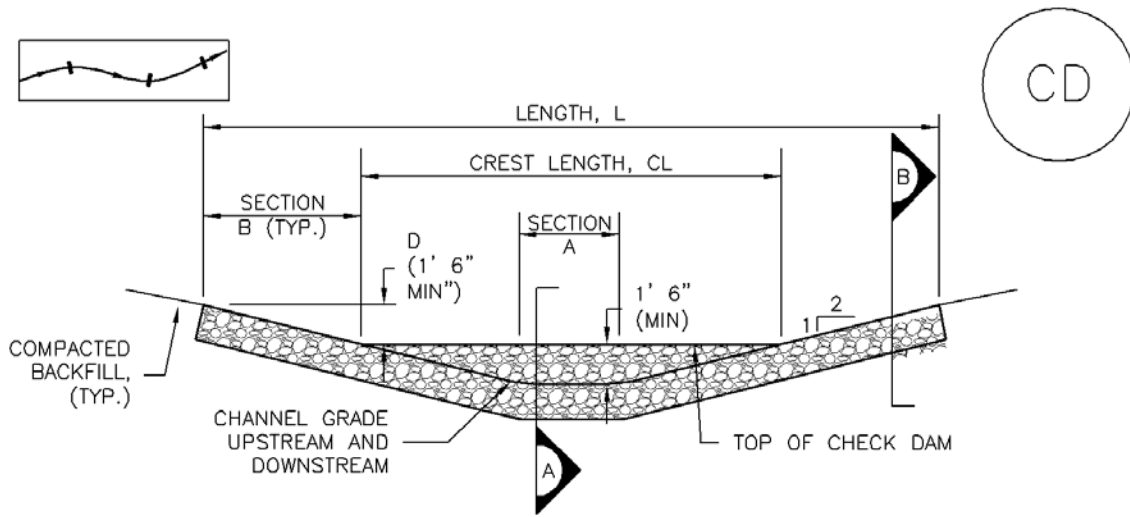

CHECK DAM ELEVATION VIEW

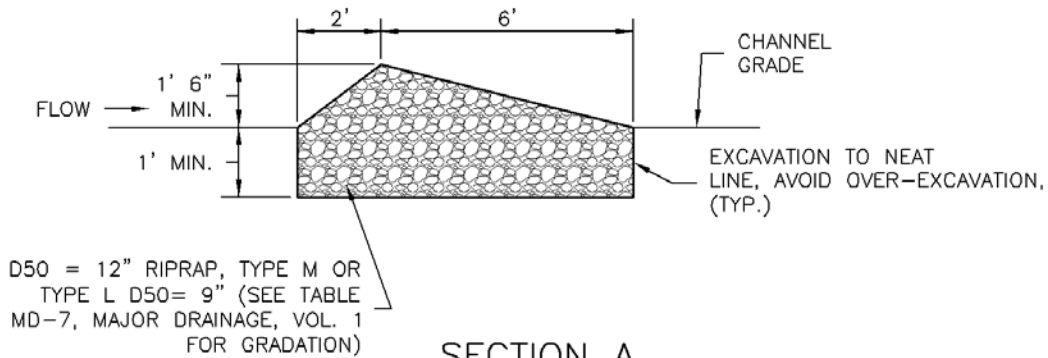

SECTION A

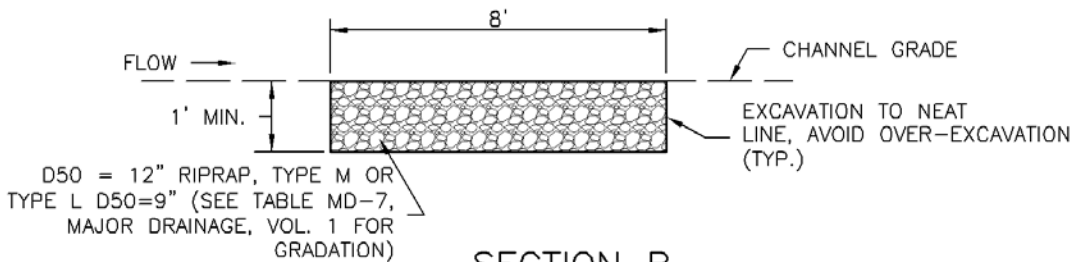

SECTION B

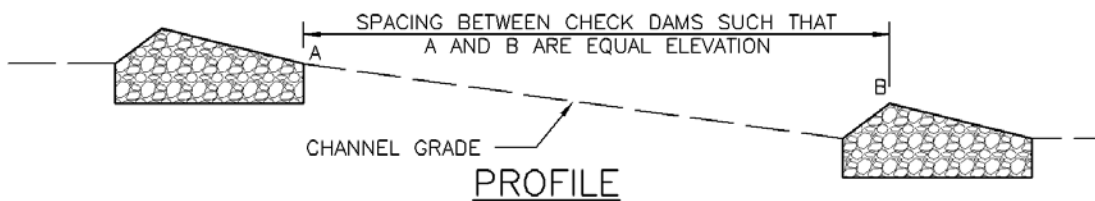

PROFILE

CD-1. CHECK DAM

CHECK DAM INSTALLATION NOTES

1. SEE PLAN VIEW FOR:
 - LOCATION OF CHECK DAMS.
 - CHECK DAM TYPE (CHECK DAM OR REINFORCED CHECK DAM).
 - LENGTH (L), CREST LENGTH (CL), AND DEPTH (D).
2. CHECK DAMS INDICATED ON INITIAL SWMP SHALL BE INSTALLED AFTER CONSTRUCTION FENCE, BUT PRIOR TO ANY UPSTREAM LAND DISTURBING ACTIVITIES.
3. RIPRAP UTILIZED FOR CHECK DAMS SHOULD BE OF APPROPRIATE SIZE FOR THE APPLICATION. TYPICAL TYPES OF RIPRAP USED FOR CHECK DAMS ARE TYPE M (D50 12") OR TYPE L (D50 9").
4. RIPRAP PAD SHALL BE TRENCHED INTO THE GROUND A MINIMUM OF 1'.
5. THE ENDS OF THE CHECK DAM SHALL BE A MINIMUM OF 1' 6" HIGHER THAN THE CENTER OF THE CHECK DAM.

CHECK DAM MAINTENANCE NOTES

1. INSPECT BMPs EACH WORKDAY, AND MAINTAIN THEM IN EFFECTIVE OPERATING CONDITION. MAINTENANCE OF BMPs SHOULD BE PROACTIVE, NOT REACTIVE. INSPECT BMPs AS SOON AS POSSIBLE (AND ALWAYS WITHIN 24 HOURS) FOLLOWING A STORM THAT CAUSES SURFACE EROSION, AND PERFORM NECESSARY MAINTENANCE.
2. FREQUENT OBSERVATIONS AND MAINTENANCE ARE NECESSARY TO MAINTAIN BMPs IN EFFECTIVE OPERATING CONDITION. INSPECTIONS AND CORRECTIVE MEASURES SHOULD BE DOCUMENTED THOROUGHLY.
3. WHERE BMPs HAVE FAILED, REPAIR OR REPLACEMENT SHOULD BE INITIATED UPON DISCOVERY OF THE FAILURE.
4. SEDIMENT ACCUMULATED UPSTREAM OF THE CHECK DAMS SHALL BE REMOVED WHEN THE SEDIMENT DEPTH IS WITHIN $\frac{1}{2}$ OF THE HEIGHT OF THE CREST.
5. CHECK DAMS ARE TO REMAIN IN PLACE UNTIL THE UPSTREAM DISTURBED AREA IS STABILIZED AND APPROVED BY THE LOCAL JURISDICTION.
6. WHEN CHECK DAMS ARE REMOVED, EXCAVATIONS SHALL BE FILLED WITH SUITABLE COMPACTED BACKFILL. DISTURBED AREA SHALL BE SEEDED AND MULCHED AND COVERED WITH GEOTEXTILE OR OTHERWISE STABILIZED IN A MANNER APPROVED BY THE LOCAL JURISDICTION.

(DETAILS ADAPTED FROM DOUGLAS COUNTY, COLORADO, NOT AVAILABLE IN AUTOCAD)

NOTE: MANY JURISDICTIONS HAVE BMP DETAILS THAT VARY FROM UDFCD STANDARD DETAILS. CONSULT WITH LOCAL JURISDICTIONS AS TO WHICH DETAIL SHOULD BE USED WHEN DIFFERENCES ARE NOTED.

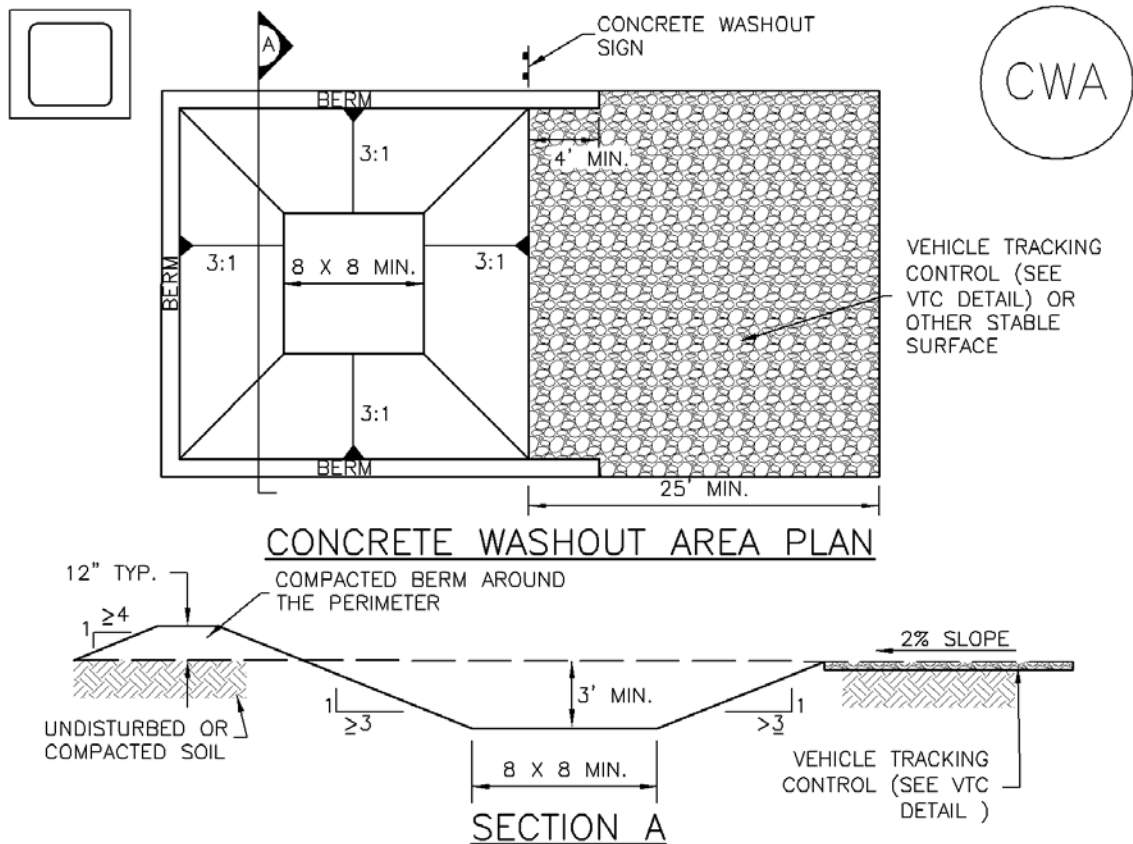

CWA-1. CONCRETE WASHOUT AREA

CWA INSTALLATION NOTES

1. SEE PLAN VIEW FOR:
-CWA INSTALLATION LOCATION.
2. DO NOT LOCATE AN UNLINED CWA WITHIN 400' OF ANY NATURAL DRAINAGE PATHWAY OR WATERBODY. DO NOT LOCATE WITHIN 1,000' OF ANY WELLS OR DRINKING WATER SOURCES. IF SITE CONSTRAINTS MAKE THIS INFEASIBLE, OR IF HIGHLY PERMEABLE SOILS EXIST ON SITE, THE CWA MUST BE INSTALLED WITH AN IMPERMEABLE LINER (16 MIL MIN. THICKNESS) OR SURFACE STORAGE ALTERNATIVES USING PREFABRICATED CONCRETE WASHOUT DEVICES OR A LINED ABOVE GROUND STORAGE ARE SHOULD BE USED.
3. THE CWA SHALL BE INSTALLED PRIOR TO CONCRETE PLACEMENT ON SITE.
4. CWA SHALL INCLUDE A FLAT SUBSURFACE PIT THAT IS AT LEAST 8' BY 8' SLOPES LEADING OUT OF THE SUBSURFACE PIT SHALL BE 3:1 OR FLATTER. THE PIT SHALL BE AT LEAST 3' DEEP.
5. BERM SURROUNDING SIDES AND BACK OF THE CWA SHALL HAVE MINIMUM HEIGHT OF 1'.
6. VEHICLE TRACKING PAD SHALL BE SLOPED 2% TOWARDS THE CWA.
7. SIGNS SHALL BE PLACED AT THE CONSTRUCTION ENTRANCE, AT THE CWA, AND ELSEWHERE AS NECESSARY TO CLEARLY INDICATE THE LOCATION OF THE CWA TO OPERATORS OF CONCRETE TRUCKS AND PUMP RIGS.
8. USE EXCAVATED MATERIAL FOR PERIMETER BERM CONSTRUCTION.

CWA MAINTENANCE NOTES

1. INSPECT BMPs EACH WORKDAY, AND MAINTAIN THEM IN EFFECTIVE OPERATING CONDITION. MAINTENANCE OF BMPs SHOULD BE PROACTIVE, NOT REACTIVE. INSPECT BMPs AS SOON AS POSSIBLE (AND ALWAYS WITHIN 24 HOURS) FOLLOWING A STORM THAT CAUSES SURFACE EROSION, AND PERFORM NECESSARY MAINTENANCE.

2. FREQUENT OBSERVATIONS AND MAINTENANCE ARE NECESSARY TO MAINTAIN BMPs IN EFFECTIVE OPERATING CONDITION. INSPECTIONS AND CORRECTIVE MEASURES SHOULD BE DOCUMENTED THOROUGHLY.

3. WHERE BMPs HAVE FAILED, REPAIR OR REPLACEMENT SHOULD BE INITIATED UPON DISCOVERY OF THE FAILURE.

4. THE CWA SHALL BE REPAIRED, CLEANED, OR ENLARGED AS NECESSARY TO MAINTAIN CAPACITY FOR CONCRETE WASTE. CONCRETE MATERIALS, ACCUMULATED IN PIT, SHALL BE REMOVED ONCE THE MATERIALS HAVE REACHED A DEPTH OF 2'.

5. CONCRETE WASHOUT WATER, WASTED PIECES OF CONCRETE AND ALL OTHER DEBRIS IN THE SUBSURFACE PIT SHALL BE TRANSPORTED FROM THE JOB SITE IN A WATER-TIGHT CONTAINER AND DISPOSED OF PROPERLY.

6. THE CWA SHALL REMAIN IN PLACE UNTIL ALL CONCRETE FOR THE PROJECT IS PLACED.

7. WHEN THE CWA IS REMOVED, COVER THE DISTURBED AREA WITH TOP SOIL, SEED AND MULCH OR OTHERWISE STABILIZED IN A MANNER APPROVED BY THE LOCAL JURISDICTION.

(DETAIL ADAPTED FROM DOUGLAS COUNTY, COLORADO AND THE CITY OF PARKER, COLORADO, NOT AVAILABLE IN AUTOCAD).

NOTE: MANY JURISDICTIONS HAVE BMP DETAILS THAT VARY FROM UDFCD STANDARD DETAILS. CONSULT WITH LOCAL JURISDICTIONS AS TO WHICH DETAIL SHOULD BE USED WHEN DIFFERENCES ARE NOTED.

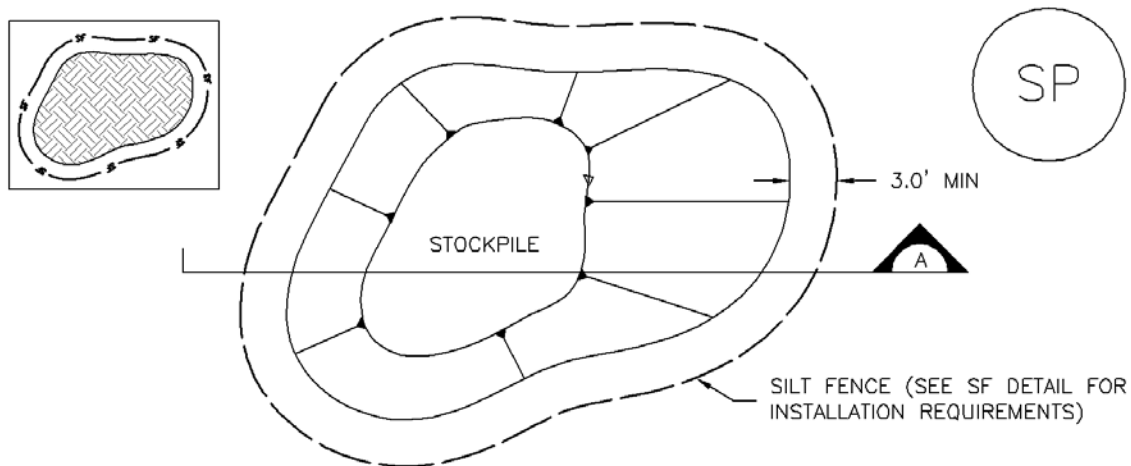

STOCKPILE PROTECTION PLAN

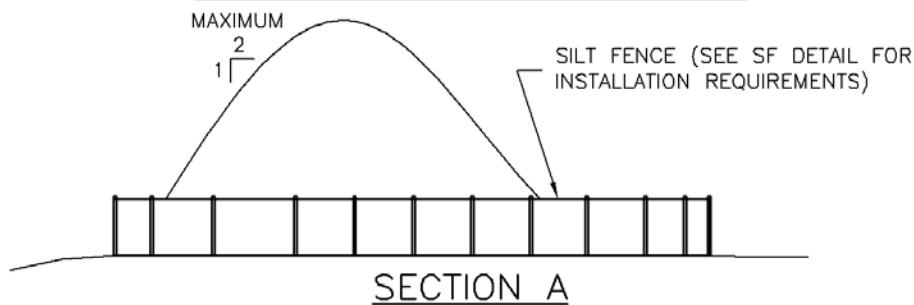

SP-1. STOCKPILE PROTECTION

STOCKPILE PROTECTION INSTALLATION NOTES

1. SEE PLAN VIEW FOR:
 - LOCATION OF STOCKPILES.
 - TYPE OF STOCKPILE PROTECTION.

2. INSTALL PERIMETER CONTROLS IN ACCORDANCE WITH THEIR RESPECTIVE DESIGN DETAILS. SILT FENCE IS SHOWN IN THE STOCKPILE PROTECTION DETAILS; HOWEVER, OTHER TYPES OF PERIMETER CONTROLS INCLUDING SEDIMENT CONTROL LOGS OR ROCK SOCKS MAY BE SUITABLE IN SOME CIRCUMSTANCES. CONSIDERATIONS FOR DETERMINING THE APPROPRIATE TYPE OF PERIMETER CONTROL FOR A STOCKPILE INCLUDE WHETHER THE STOCKPILE IS LOCATED ON A PERVIOUS OR IMPERVIOUS SURFACE, THE RELATIVE HEIGHTS OF THE PERIMETER CONTROL AND STOCKPILE, THE ABILITY OF THE PERIMETER CONTROL TO CONTAIN THE STOCKPILE WITHOUT FAILING IN THE EVENT THAT MATERIAL FROM THE STOCKPILE SHIFTS OR SLUMPS AGAINST THE PERIMETER, AND OTHER FACTORS.

3. STABILIZE THE STOCKPILE SURFACE WITH SURFACE ROUGHENING, TEMPORARY SEEDING AND MULCHING, EROSION CONTROL BLANKETS, OR SOIL BINDERS. SOILS STOCKPILED FOR AN EXTENDED PERIOD (TYPICALLY FOR MORE THAN 60 DAYS) SHOULD BE SEEDING AND MULCHED WITH A TEMPORARY GRASS COVER ONCE THE STOCKPILE IS PLACED (TYPICALLY WITHIN 14 DAYS). USE OF MULCH ONLY OR A SOIL BINDER IS ACCEPTABLE IF THE STOCKPILE WILL BE IN PLACE FOR A MORE LIMITED TIME PERIOD (TYPICALLY 30-60 DAYS).

4. FOR TEMPORARY STOCKPILES ON THE INTERIOR PORTION OF A CONSTRUCTION SITE, WHERE OTHER DOWNGRADIENT CONTROLS, INCLUDING PERIMETER CONTROL, ARE IN PLACE, STOCKPILE PERIMETER CONTROLS MAY NOT BE REQUIRED.

STOCKPILE PROTECTION MAINTENANCE NOTES

1. INSPECT BMPs EACH WORKDAY, AND MAINTAIN THEM IN EFFECTIVE OPERATING CONDITION. MAINTENANCE OF BMPs SHOULD BE PROACTIVE, NOT REACTIVE. INSPECT BMPs AS SOON AS POSSIBLE (AND ALWAYS WITHIN 24 HOURS) FOLLOWING A STORM THAT CAUSES SURFACE EROSION, AND PERFORM NECESSARY MAINTENANCE.

2. FREQUENT OBSERVATIONS AND MAINTENANCE ARE NECESSARY TO MAINTAIN BMPs IN EFFECTIVE OPERATING CONDITION. INSPECTIONS AND CORRECTIVE MEASURES SHOULD BE DOCUMENTED THOROUGHLY.

3. WHERE BMPs HAVE FAILED, REPAIR OR REPLACEMENT SHOULD BE INITIATED UPON DISCOVERY OF THE FAILURE.

STOCKPILE PROTECTION MAINTENANCE NOTES

4. IF PERIMETER PROTECTION MUST BE MOVED TO ACCESS SOIL STOCKPILE, REPLACE PERIMETER CONTROLS BY THE END OF THE WORKDAY.

5. STOCKPILE PERIMETER CONTROLS CAN BE REMOVED ONCE ALL THE MATERIAL FROM THE STOCKPILE HAS BEEN USED.

(DETAILS ADAPTED FROM PARKER, COLORADO, NOT AVAILABLE IN AUTOCAD)

NOTE: MANY JURISDICTIONS HAVE BMP DETAILS THAT VARY FROM UDFCD STANDARD DETAILS. CONSULT WITH LOCAL JURISDICTIONS AS TO WHICH DETAIL SHOULD BE USED WHEN DIFFERENCES ARE NOTED.

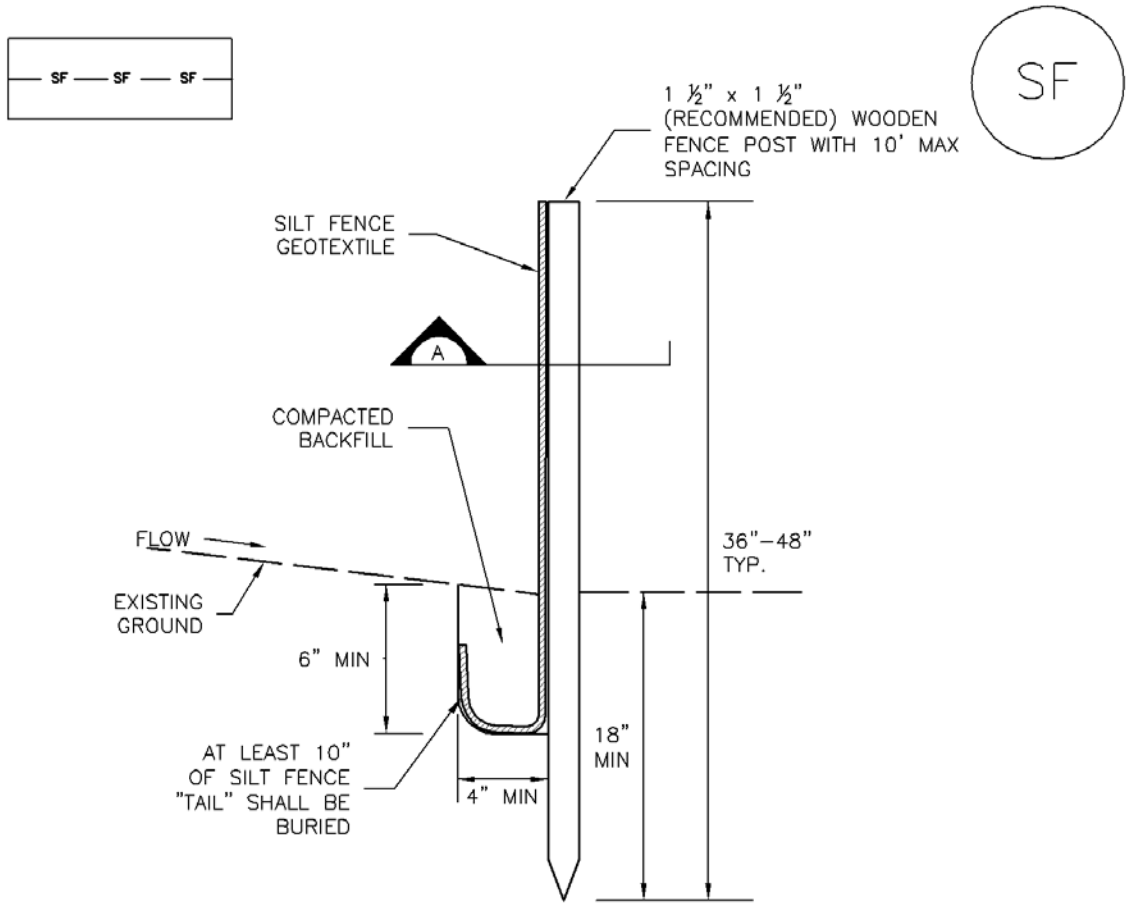

SILT FENCE

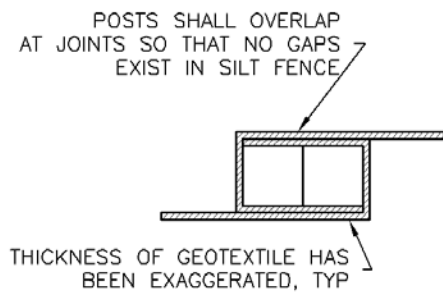
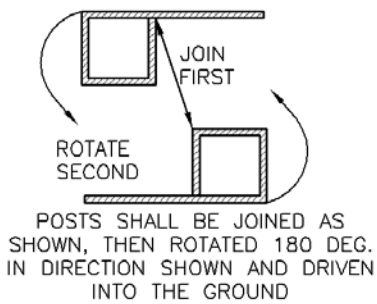

SECTION A

SF-1. SILT FENCE

SILT FENCE INSTALLATION NOTES

1. SILT FENCE MUST BE PLACED AWAY FROM THE TOE OF THE SLOPE TO ALLOW FOR WATER PONDING. SILT FENCE AT THE TOE OF A SLOPE SHOULD BE INSTALLED IN A FLAT LOCATION AT LEAST SEVERAL FEET (2-5 FT) FROM THE TOE OF THE SLOPE TO ALLOW ROOM FOR PONDING AND DEPOSITION.
2. A UNIFORM 6" X 4" ANCHOR TRENCH SHALL BE EXCAVATED USING TRENCHER OR SILT FENCE INSTALLATION DEVICE. NO ROAD GRADERS, BACKHOES, OR SIMILAR EQUIPMENT SHALL BE USED.
3. COMPACT ANCHOR TRENCH BY HAND WITH A "JUMPING JACK" OR BY WHEEL ROLLING. COMPACTION SHALL BE SUCH THAT SILT FENCE RESISTS BEING PULLED OUT OF ANCHOR TRENCH BY HAND.
4. SILT FENCE SHALL BE PULLED TIGHT AS IT IS ANCHORED TO THE STAKES. THERE SHOULD BE NO NOTICEABLE SAG BETWEEN STAKES AFTER IT HAS BEEN ANCHORED TO THE STAKES.
5. SILT FENCE FABRIC SHALL BE ANCHORED TO THE STAKES USING 1" HEAVY DUTY STAPLES OR NAILS WITH 1" HEADS. STAPLES AND NAILS SHOULD BE PLACED 3" ALONG THE FABRIC DOWN THE STAKE.
6. AT THE END OF A RUN OF SILT FENCE ALONG A CONTOUR, THE SILT FENCE SHOULD BE TURNED PERPENDICULAR TO THE CONTOUR TO CREATE A "J-HOOK." THE "J-HOOK" EXTENDING PERPENDICULAR TO THE CONTOUR SHOULD BE OF SUFFICIENT LENGTH TO KEEP RUNOFF FROM FLOWING AROUND THE END OF THE SILT FENCE (TYPICALLY 10' - 20').
7. SILT FENCE SHALL BE INSTALLED PRIOR TO ANY LAND DISTURBING ACTIVITIES.

SILT FENCE MAINTENANCE NOTES

1. INSPECT BMPs EACH WORKDAY, AND MAINTAIN THEM IN EFFECTIVE OPERATING CONDITION. MAINTENANCE OF BMPs SHOULD BE PROACTIVE, NOT REACTIVE. INSPECT BMPs AS SOON AS POSSIBLE (AND ALWAYS WITHIN 24 HOURS) FOLLOWING A STORM THAT CAUSES SURFACE EROSION, AND PERFORM NECESSARY MAINTENANCE.
2. FREQUENT OBSERVATIONS AND MAINTENANCE ARE NECESSARY TO MAINTAIN BMPs IN EFFECTIVE OPERATING CONDITION. INSPECTIONS AND CORRECTIVE MEASURES SHOULD BE DOCUMENTED THOROUGHLY.
3. WHERE BMPs HAVE FAILED, REPAIR OR REPLACEMENT SHOULD BE INITIATED UPON DISCOVERY OF THE FAILURE.
4. SEDIMENT ACCUMULATED UPSTREAM OF THE SILT FENCE SHALL BE REMOVED AS NEEDED TO MAINTAIN THE FUNCTIONALITY OF THE BMP, TYPICALLY WHEN DEPTH OF ACCUMULATED SEDIMENTS IS APPROXIMATELY 6".
5. REPAIR OR REPLACE SILT FENCE WHEN THERE ARE SIGNS OF WEAR, SUCH AS SAGGING, TEARING, OR COLLAPSE.
6. SILT FENCE IS TO REMAIN IN PLACE UNTIL THE UPSTREAM DISTURBED AREA IS STABILIZED AND APPROVED BY THE LOCAL JURISDICTION, OR IS REPLACED BY AN EQUIVALENT PERIMETER SEDIMENT CONTROL BMP.
7. WHEN SILT FENCE IS REMOVED, ALL DISTURBED AREAS SHALL BE COVERED WITH TOPSOIL, SEEDED AND MULCHED OR OTHERWISE STABILIZED AS APPROVED BY LOCAL JURISDICTION.

(DETAIL ADAPTED FROM TOWN OF PARKER, COLORADO AND CITY OF AURORA, NOT AVAILABLE IN AUTOCAD)

NOTE: MANY JURISDICTIONS HAVE BMP DETAILS THAT VARY FROM UDFCD STANDARD DETAILS. CONSULT WITH LOCAL JURISDICTIONS AS TO WHICH DETAIL SHOULD BE USED WHEN DIFFERENCES ARE NOTED.

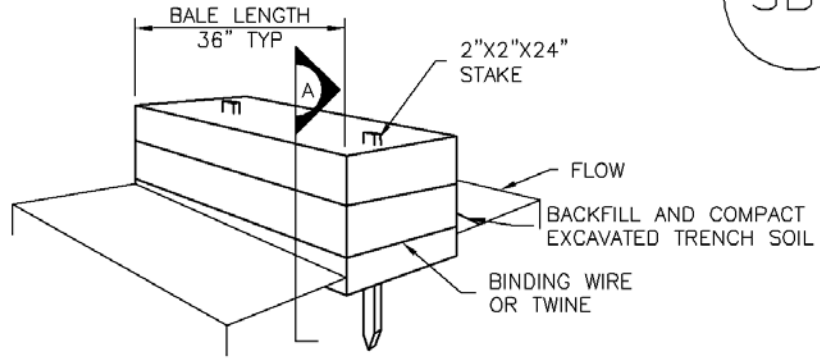

STRAW BALE

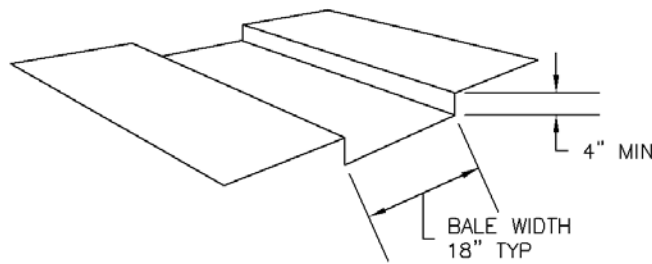

TRENCH FOR STRAW BALE

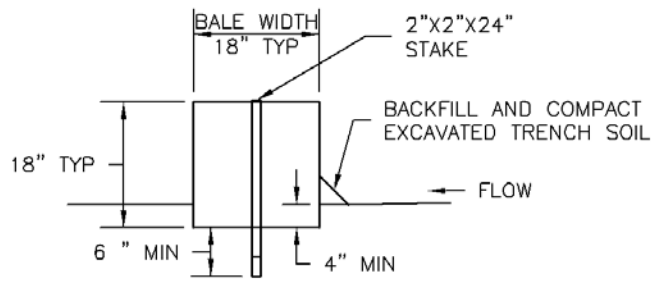

SECTION A

SBB-1. STRAW BALE

STRAW BALE INSTALLATION NOTES

1. SEE PLAN VIEW FOR:
-LOCATION(S) OF STRAW BALES.
2. STRAW BALES SHALL CONSIST OF CERTIFIED WEED FREE STRAW OR HAY. LOCAL JURISDICTIONS MAY REQUIRE PROOF THAT BALES ARE WEED FREE.
3. STRAW BALES SHALL CONSIST OF APPROXIMATELY 5 CUBIC FEET OF STRAW OR HAY AND WEIGH NOT LESS THAN 35 POUNDS.
4. WHEN STRAW BALES ARE USED IN SERIES AS A BARRIER, THE END OF EACH BALE SHALL BE TIGHTLY ABUTTING ONE ANOTHER.
5. STRAW BALE DIMENSIONS SHALL BE APPROXIMATELY 36"X18"X18".
6. A UNIFORM ANCHOR TRENCH SHALL BE EXCAVATED TO A DEPTH OF 4". STRAW BALES SHALL BE PLACED SO THAT BINDING TWINE IS ENCOMPASSING THE VERTICAL SIDES OF THE BALE(S). ALL EXCAVATED SOIL SHALL BE PLACED ON THE UPHILL SIDE OF THE STRAW BALE(S) AND COMPACTED.
7. TWO (2) WOODEN STAKES SHALL BE USED TO HOLD EACH BALE IN PLACE. WOODEN STAKES SHALL BE 2"X2"X24". WOODEN STAKES SHALL BE DRIVEN 6" INTO THE GROUND.

STRAW BALE MAINTENANCE NOTES

1. INSPECT BMPs EACH WORKDAY, AND MAINTAIN THEM IN EFFECTIVE OPERATING CONDITION. MAINTENANCE OF BMPs SHOULD BE PROACTIVE, NOT REACTIVE. INSPECT BMPs AS SOON AS POSSIBLE (AND ALWAYS WITHIN 24 HOURS) FOLLOWING A STORM THAT CAUSES SURFACE EROSION, AND PERFORM NECESSARY MAINTENANCE.
2. FREQUENT OBSERVATIONS AND MAINTENANCE ARE NECESSARY TO MAINTAIN BMPs IN EFFECTIVE OPERATING CONDITION. INSPECTIONS AND CORRECTIVE MEASURES SHOULD BE DOCUMENTED THOROUGHLY.
3. WHERE BMPs HAVE FAILED, REPAIR OR REPLACEMENT SHOULD BE INITIATED UPON DISCOVERY OF THE FAILURE.
4. STRAW BALES SHALL BE REPLACED IF THEY BECOME HEAVILY SOILED, ROTTEN, OR DAMAGED BEYOND REPAIR.
5. SEDIMENT ACCUMULATED UPSTREAM OF STRAW BALE BARRIER SHALL BE REMOVED AS NEEDED TO MAINTAIN FUNCTIONALITY OF THE BMP, TYPICALLY WHEN DEPTH OF ACCUMULATED SEDIMENTS IS APPROXIMATELY $\frac{1}{4}$ OF THE HEIGHT OF THE STRAW BALE BARRIER.
6. STRAW BALES ARE TO REMAIN IN PLACE UNTIL THE UPSTREAM DISTURBED AREA IS STABILIZED AND APPROVED BY THE LOCAL JURISDICTION.
7. WHEN STRAW BALES ARE REMOVED, ALL DISTURBED AREAS SHALL BE COVERED WITH TOPSOIL, SEEDED AND MULCHED OR OTHERWISE STABILIZED AS APPROVED BY LOCAL JURISDICTION.

(DETAILS ADAPTED FROM TOWN OF PARKER, COLORADO, NOT AVAILABLE IN AUTOCAD)

NOTE: MANY JURISDICTIONS HAVE BMP DETAILS THAT VARY FROM UDFCD STANDARD DETAILS. CONSULT WITH LOCAL JURISDICTIONS AS TO WHICH DETAIL SHOULD BE USED WHEN DIFFERENCES ARE NOTED.

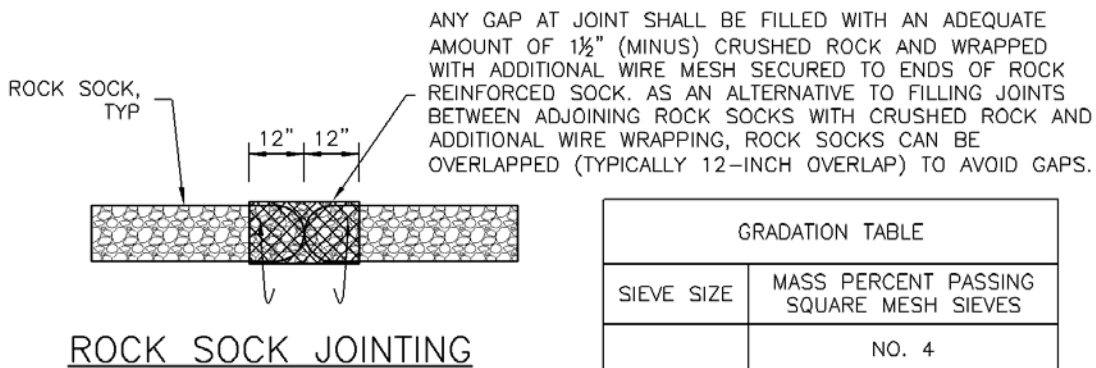
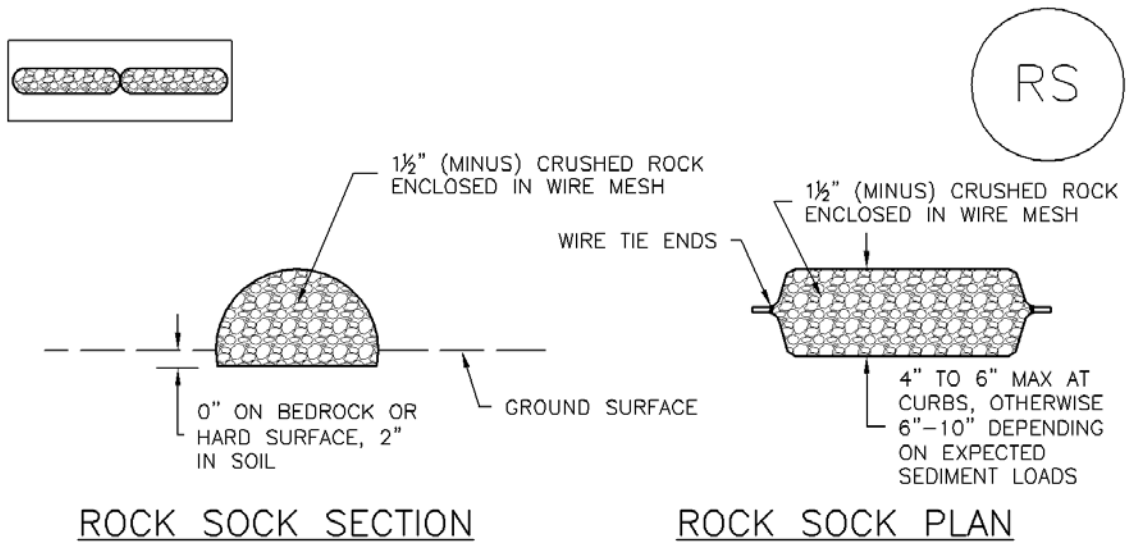

GRADATION TABLE	
SIEVE SIZE	MASS PERCENT PASSING SQUARE MESH SIEVES
	NO. 4
2"	100
1 1/2"	90 - 100
1"	20 - 55
3/4"	0 - 15
3/8"	0 - 5
MATCHES SPECIFICATIONS FOR NO. 4 COARSE AGGREGATE FOR CONCRETE PER AASHTO M43. ALL ROCK SHALL BE FRACTURED FACE, ALL SIDES.	

ROCK SOCK INSTALLATION NOTES

1. SEE PLAN VIEW FOR:
-LOCATION(S) OF ROCK SOCKS.
2. CRUSHED ROCK SHALL BE 1 1/2" (MINUS) IN SIZE WITH A FRACTURED FACE (ALL SIDES) AND SHALL COMPLY WITH GRADATION SHOWN ON THIS SHEET (1 1/2" MINUS).
3. WIRE MESH SHALL BE FABRICATED OF 10 GAGE POULTRY MESH, OR EQUIVALENT, WITH A MAXIMUM OPENING OF 1/2", RECOMMENDED MINIMUM ROLL WIDTH OF 48"
4. WIRE MESH SHALL BE SECURED USING "HOG RINGS" OR WIRE TIES AT 6" CENTERS ALONG ALL JOINTS AND AT 2" CENTERS ON ENDS OF SOCKS.
5. SOME MUNICIPALITIES MAY ALLOW THE USE OF FILTER FABRIC AS AN ALTERNATIVE TO WIRE MESH FOR THE ROCK ENCLOSURE.

RS-1. ROCK SOCK PERIMETER CONTROL

ROCK SOCK MAINTENANCE NOTES

1. INSPECT BMPs EACH WORKDAY, AND MAINTAIN THEM IN EFFECTIVE OPERATING CONDITION. MAINTENANCE OF BMPs SHOULD BE PROACTIVE, NOT REACTIVE. INSPECT BMPs AS SOON AS POSSIBLE (AND ALWAYS WITHIN 24 HOURS) FOLLOWING A STORM THAT CAUSES SURFACE EROSION, AND PERFORM NECESSARY MAINTENANCE.
2. FREQUENT OBSERVATIONS AND MAINTENANCE ARE NECESSARY TO MAINTAIN BMPs IN EFFECTIVE OPERATING CONDITION. INSPECTIONS AND CORRECTIVE MEASURES SHOULD BE DOCUMENTED THOROUGHLY.
3. WHERE BMPs HAVE FAILED, REPAIR OR REPLACEMENT SHOULD BE INITIATED UPON DISCOVERY OF THE FAILURE.
4. ROCK SOCKS SHALL BE REPLACED IF THEY BECOME HEAVILY SOILED, OR DAMAGED BEYOND REPAIR.
5. SEDIMENT ACCUMULATED UPSTREAM OF ROCK SOCKS SHALL BE REMOVED AS NEEDED TO MAINTAIN FUNCTIONALITY OF THE BMP, TYPICALLY WHEN DEPTH OF ACCUMULATED SEDIMENTS IS APPROXIMATELY $\frac{1}{2}$ OF THE HEIGHT OF THE ROCK SOCK.
6. ROCK SOCKS ARE TO REMAIN IN PLACE UNTIL THE UPSTREAM DISTURBED AREA IS STABILIZED AND APPROVED BY THE LOCAL JURISDICTION.
7. WHEN ROCK SOCKS ARE REMOVED, ALL DISTURBED AREAS SHALL BE COVERED WITH TOPSOIL, SEEDED AND MULCHED OR OTHERWISE STABILIZED AS APPROVED BY LOCAL JURISDICTION.

(DETAIL ADAPTED FROM TOWN OF PARKER, COLORADO AND CITY OF AURORA, COLORADO, NOT AVAILABLE IN AUTOCAD)

NOTE: MANY JURISDICTIONS HAVE BMP DETAILS THAT VARY FROM UDFCD STANDARD DETAILS. CONSULT WITH LOCAL JURISDICTIONS AS TO WHICH DETAIL SHOULD BE USED WHEN DIFFERENCES ARE NOTED.

NOTE: THE DETAILS INCLUDED WITH THIS FACT SHEET SHOW COMMONLY USED, CONVENTIONAL METHODS OF ROCK SOCK INSTALLATION IN THE DENVER METROPOLITAN AREA. THERE ARE MANY OTHER SIMILAR PROPRIETARY PRODUCTS ON THE MARKET. UDFCD NEITHER NDORSES NOR DISCOURAGES USE OF PROPRIETARY PROTECTION PRODUCTS; HOWEVER, IN THE EVENT PROPRIETARY METHODS ARE USED, THE APPROPRIATE DETAIL FROM THE MANUFACTURER MUST BE INCLUDED IN THE SWMP AND THE BMP MUST BE INSTALLED AND MAINTAINED AS SHOWN IN THE MANUFACTURER'S DETAILS.

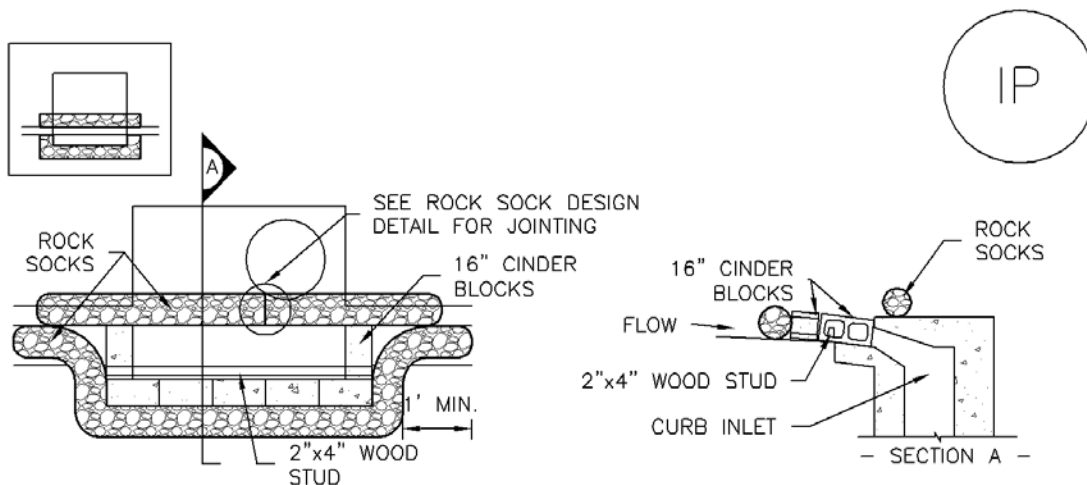

IP-1. BLOCK AND ROCK SOCK SUMP OR ON GRADE INLET PROTECTION

BLOCK AND CURB SOCK INLET PROTECTION INSTALLATION NOTES

1. SEE ROCK SOCK DESIGN DETAIL FOR INSTALLATION REQUIREMENTS.
2. CONCRETE "CINDER" BLOCKS SHALL BE LAID ON THEIR SIDES AROUND THE INLET IN A SINGLE ROW, ABUTTING ONE ANOTHER WITH THE OPEN END FACING AWAY FROM THE CURB.
3. GRAVEL BAGS SHALL BE PLACED AROUND CONCRETE BLOCKS, CLOSELY ABUTTING ONE ANOTHER AND JOINTED TOGETHER IN ACCORDANCE WITH ROCK SOCK DESIGN DETAIL.

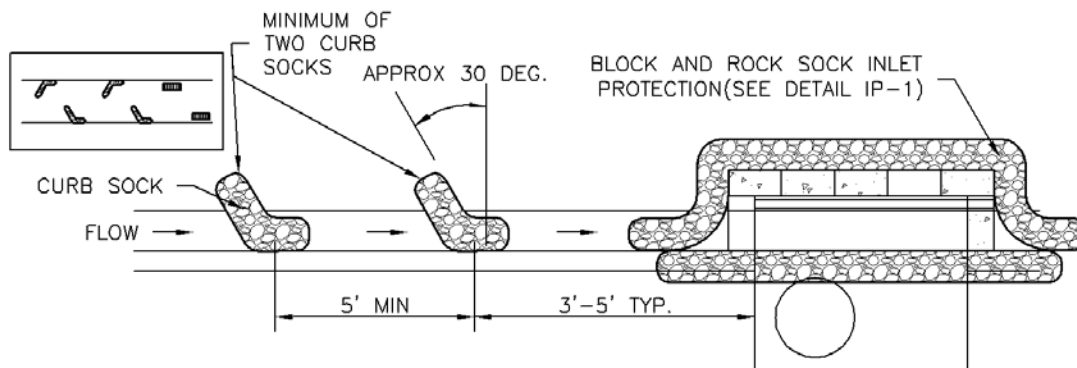

IP-2. CURB ROCK SOCKS UPSTREAM OF INLET PROTECTION

CURB ROCK SOCK INLET PROTECTION INSTALLATION NOTES

1. SEE ROCK SOCK DESIGN DETAIL INSTALLATION REQUIREMENTS.
2. PLACEMENT OF THE SOCK SHALL BE APPROXIMATELY 30 DEGREES FROM PERPENDICULAR IN THE OPPOSITE DIRECTION OF FLOW.
3. SOCKS ARE TO BE FLUSH WITH THE CURB AND SPACED A MINIMUM OF 5 FEET APART.
4. AT LEAST TWO CURB SOCKS IN SERIES ARE REQUIRED UPSTREAM OF ON-GRADE INLETS.

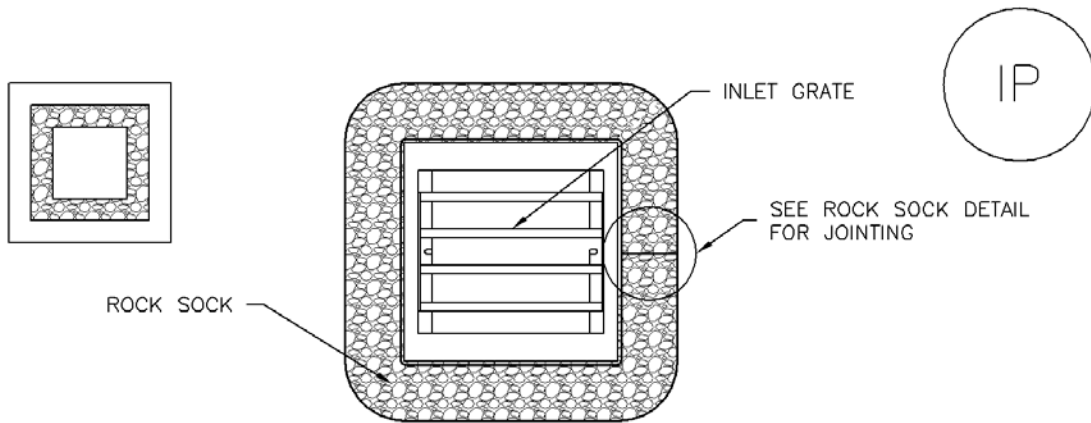

IP-3. ROCK SOCK SUMP/AREA INLET PROTECTION

ROCK SOCK SUMP/AREA INLET PROTECTION INSTALLATION NOTES

1. SEE ROCK SOCK DESIGN DETAIL FOR INSTALLATION REQUIREMENTS.
2. STRAW WATTLES/SEDIMENT CONTROL LOGS MAY BE USED IN PLACE OF ROCK SOCKS FOR INLETS IN PERVIOUS AREAS. INSTALL PER SEDIMENT CONTROL LOG DETAIL.

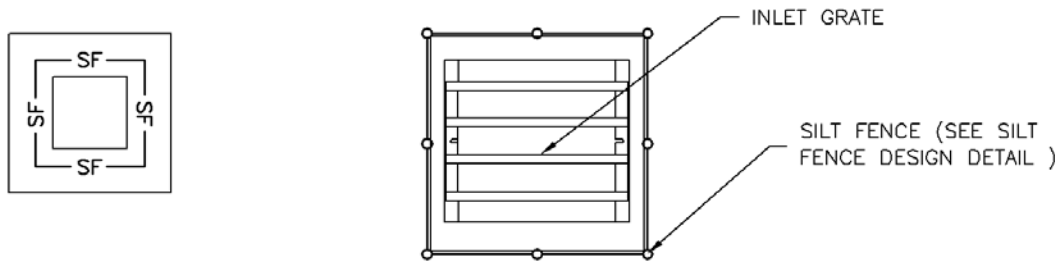

IP-4. SILT FENCE FOR SUMP INLET PROTECTION

SILT FENCE INLET PROTECTION INSTALLATION NOTES

1. SEE SILT FENCE DESIGN DETAIL FOR INSTALLATION REQUIREMENTS.
2. POSTS SHALL BE PLACED AT EACH CORNER OF THE INLET AND AROUND THE EDGES AT A MAXIMUM SPACING OF 3 FEET.
3. STRAW WATTLES/SEDIMENT CONTROL LOGS MAY BE USED IN PLACE OF SILT FENCE FOR INLETS IN PERVIOUS AREAS. INSTALL PER SEDIMENT CONTROL LOG DETAIL.

GENERAL INLET PROTECTION INSTALLATION NOTES

1. SEE PLAN VIEW FOR:
 - LOCATION OF INLET PROTECTION.
 - TYPE OF INLET PROTECTION (IP.1, IP.2, IP.3, IP.4, IP.5, IP.6)
2. INLET PROTECTION SHALL BE INSTALLED PROMPTLY AFTER INLET CONSTRUCTION OR PAVING IS COMPLETE (TYPICALLY WITHIN 48 HOURS). IF A RAINFALL/RUNOFF EVENT IS FORECAST, INSTALL INLET PROTECTION PRIOR TO ONSET OF EVENT.
3. MANY JURISDICTIONS HAVE BMP DETAILS THAT VARY FROM UDFCD STANDARD DETAILS. CONSULT WITH LOCAL JURISDICTIONS AS TO WHICH DETAIL SHOULD BE USED WHEN DIFFERENCES ARE NOTED.

INLET PROTECTION MAINTENANCE NOTES

1. INSPECT BMPs EACH WORKDAY, AND MAINTAIN THEM IN EFFECTIVE OPERATING CONDITION. MAINTENANCE OF BMPs SHOULD BE PROACTIVE, NOT REACTIVE. INSPECT BMPs AS SOON AS POSSIBLE (AND ALWAYS WITHIN 24 HOURS) FOLLOWING A STORM THAT CAUSES SURFACE EROSION, AND PERFORM NECESSARY MAINTENANCE.
2. FREQUENT OBSERVATIONS AND MAINTENANCE ARE NECESSARY TO MAINTAIN BMPs IN EFFECTIVE OPERATING CONDITION. INSPECTIONS AND CORRECTIVE MEASURES SHOULD BE DOCUMENTED THOROUGHLY.
3. WHERE BMPs HAVE FAILED, REPAIR OR REPLACEMENT SHOULD BE INITIATED UPON DISCOVERY OF THE FAILURE.
4. SEDIMENT ACCUMULATED UPSTREAM OF INLET PROTECTION SHALL BE REMOVED AS NECESSARY TO MAINTAIN BMP EFFECTIVENESS, TYPICALLY WHEN STORAGE VOLUME REACHES 50% OF CAPACITY, A DEPTH OF 6" WHEN SILT FENCE IS USED, OR ¼ OF THE HEIGHT FOR STRAW BALES.
5. INLET PROTECTION IS TO REMAIN IN PLACE UNTIL THE UPSTREAM DISTURBED AREA IS PERMANENTLY STABILIZED, UNLESS THE LOCAL JURISDICTION APPROVES EARLIER REMOVAL OF INLET PROTECTION IN STREETS.
6. WHEN INLET PROTECTION AT AREA INLETS IS REMOVED, THE DISTURBED AREA SHALL BE COVERED WITH TOP SOIL, SEEDED AND MULCHED, OR OTHERWISE STABILIZED IN A MANNER APPROVED BY THE LOCAL JURISDICTION.

(DETAIL ADAPTED FROM TOWN OF PARKER, COLORADO AND CITY OF AURORA, COLORADO, NOT AVAILABLE IN AUTOCAD)

NOTE: MANY JURISDICTIONS HAVE BMP DETAILS THAT VARY FROM UDFCD STANDARD DETAILS. CONSULT WITH LOCAL JURISDICTIONS AS TO WHICH DETAIL SHOULD BE USED WHEN DIFFERENCES ARE NOTED.

NOTE: THE DETAILS INCLUDED WITH THIS FACT SHEET SHOW COMMONLY USED, CONVENTIONAL METHODS OF INLET PROTECTION IN THE DENVER METROPOLITAN AREA. THERE ARE MANY PROPRIETARY INLET PROTECTION METHODS ON THE MARKET. UDFCD NEITHER ENDORSES NOR DISCOURAGES USE OF PROPRIETARY INLET PROTECTION; HOWEVER, IN THE EVENT PROPRIETARY METHODS ARE USED, THE APPROPRIATE DETAIL FROM THE MANUFACTURER MUST BE INCLUDED IN THE SWMP AND THE BMP MUST BE INSTALLED AND MAINTAINED AS SHOWN IN THE MANUFACTURER'S DETAILS.

NOTE: SOME MUNICIPALITIES DISCOURAGE OR PROHIBIT THE USE OF STRAW BALES FOR INLET PROTECTION. CHECK WITH LOCAL JURISDICTION TO DETERMINE IF STRAW BALE INLET PROTECTION IS ACCEPTABLE.

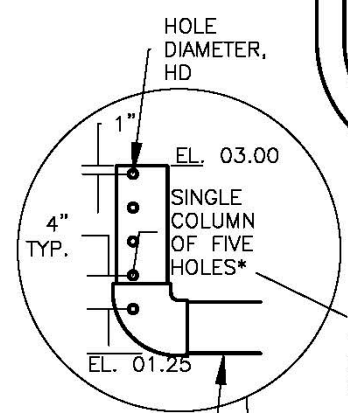
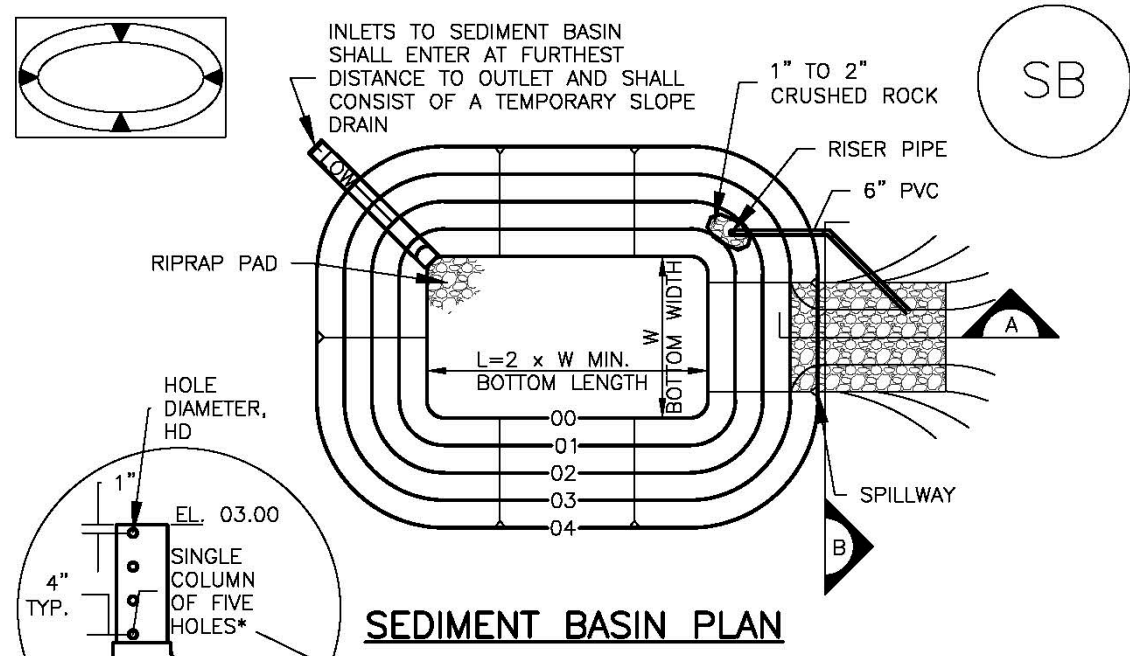

*EXCEPT WHERE THE HOLES EXCEED 1" DIAMETER, THEN UP TO TWO COLUMNS OF SAME SIZED HOLES MAY BE USED

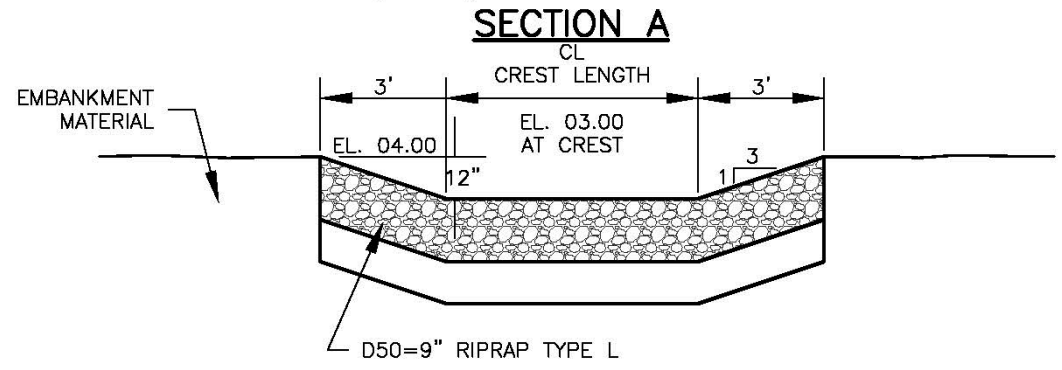
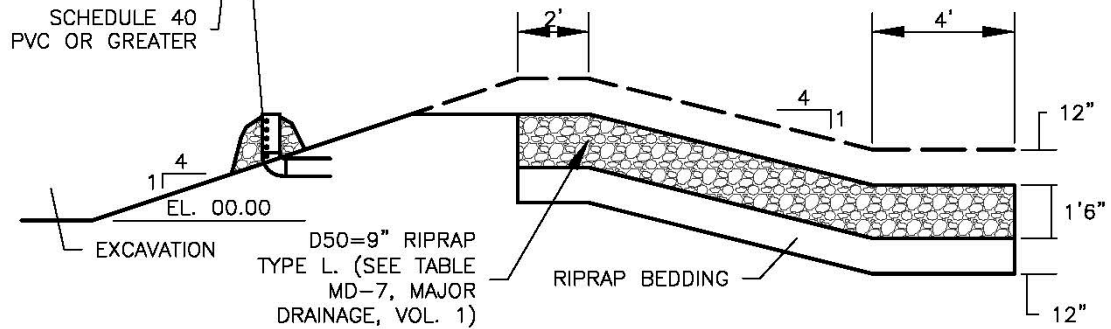

TABLE SB-1. SIZING INFORMATION FOR STANDARD SEDIMENT BASIN			
Upstream Drainage Area (rounded to nearest acre), (ac)	Basin Bottom Width (W), (ft)	Spillway Crest Length (CL), (ft)	Hole Diameter (HD), (in)
1	12 1/2	2	9/32
2	21	3	13/16
3	28	5	1/2
4	33 1/2	6	9/16
5	38 1/2	8	2 1/32
6	43	9	2 1/32
7	47 1/4	11	2 5/32
8	51	12	2 7/32
9	55	13	7/8
10	58 1/4	15	1 5/16
11	61	16	3 1/32
12	64	18	1
13	67 1/2	19	1 1/16
14	70 1/2	21	1 1/8
15	73 1/4	22	1 3/16

SEDIMENT BASIN INSTALLATION NOTES

1. SEE PLAN VIEW FOR:
 - LOCATION OF SEDIMENT BASIN.
 - TYPE OF BASIN (STANDARD BASIN OR NONSTANDARD BASIN).
 - FOR STANDARD BASIN, BOTTOM WIDTH W, CREST LENGTH CL, AND HOLE DIAMETER, HD.
 - FOR NONSTANDARD BASIN, SEE CONSTRUCTION DRAWINGS FOR DESIGN OF BASIN INCLUDING RISER HEIGHT H, NUMBER OF COLUMNS N, HOLE DIAMETER HD AND PIPE DIAMETER D.
2. FOR STANDARD BASIN, BOTTOM DIMENSION MAY BE MODIFIED AS LONG AS BOTTOM AREA IS NOT REDUCED.
3. SEDIMENT BASINS SHALL BE INSTALLED PRIOR TO ANY OTHER LAND-DISTURBING ACTIVITY THAT RELIES ON ON BASINS AS AS A STORMWATER CONTROL.
4. EMBANKMENT MATERIAL SHALL CONSIST OF SOIL FREE OF DEBRIS, ORGANIC MATERIAL, AND ROCKS OR CONCRETE GREATER THAN 3 INCHES AND SHALL HAVE A MINIMUM OF 15 PERCENT BY WEIGHT PASSING THE NO. 200 SIEVE.
5. EMBANKMENT MATERIAL SHALL BE COMPACTED TO AT LEAST 95 PERCENT OF MAXIMUM DENSITY IN ACCORDANCE WITH ASTM D698.
6. PIPE SCH 40 OR GREATER SHALL BE USED.
7. THE DETAILS SHOWN ON THESE SHEETS PERTAIN TO STANDARD SEDIMENT BASIN(S) FOR DRAINAGE AREAS LESS THAN 15 ACRES. SEE CONSTRUCTION DRAWINGS FOR EMBANKMENT, STORAGE VOLUME, SPILLWAY, OUTLET, AND OUTLET PROTECTION DETAILS FOR ANY SEDIMENT BASIN(S) THAT HAVE BEEN INDIVIDUALLY DESIGNED FOR DRAINAGE AREAS LARGER THAN 15 ACRES.

SEDIMENT BASIN MAINTENANCE NOTES

1. INSPECT BMPs EACH WORKDAY, AND MAINTAIN THEM IN EFFECTIVE OPERATING CONDITION. MAINTENANCE OF BMPs SHOULD BE PROACTIVE, NOT REACTIVE. INSPECT BMPs AS SOON AS POSSIBLE (AND ALWAYS WITHIN 24 HOURS) FOLLOWING A STORM THAT CAUSES SURFACE EROSION, AND PERFORM NECESSARY MAINTENANCE.
2. FREQUENT OBSERVATIONS AND MAINTENANCE ARE NECESSARY TO MAINTAIN BMPs IN EFFECTIVE OPERATING CONDITION. INSPECTIONS AND CORRECTIVE MEASURES SHOULD BE DOCUMENTED THOROUGHLY.
3. WHERE BMPs HAVE FAILED, REPAIR OR REPLACEMENT SHOULD BE INITIATED UPON DISCOVERY OF THE FAILURE.
4. SEDIMENT ACCUMULATED IN BASIN SHALL BE REMOVED AS NEEDED TO MAINTAIN BMP EFFECTIVENESS, TYPICALLY WHEN SEDIMENT DEPTH REACHES ONE FOOT (I.E., TWO FEET BELOW THE SPILLWAY CREST).
5. SEDIMENT BASINS ARE TO REMAIN IN PLACE UNTIL THE UPSTREAM DISTURBED AREA IS STABILIZED AND GRASS COVER IS ACCEPTED BY THE LOCAL JURISDICTION.
6. WHEN SEDIMENT BASINS ARE REMOVED, ALL DISTURBED AREAS SHALL BE COVERED WITH TOPSOIL, SEEDED AND MULCHED OR OTHERWISE STABILIZED AS APPROVED BY LOCAL JURISDICTION.

(DETAILS ADAPTED FROM DOUGLAS COUNTY, COLORADO)

NOTE: MANY JURISDICTIONS HAVE BMP DETAILS THAT VARY FROM UDFCD STANDARD DETAILS. CONSULT WITH LOCAL JURISDICTIONS AS TO WHICH DETAIL SHOULD BE USED WHEN DIFFERENCES ARE NOTED.

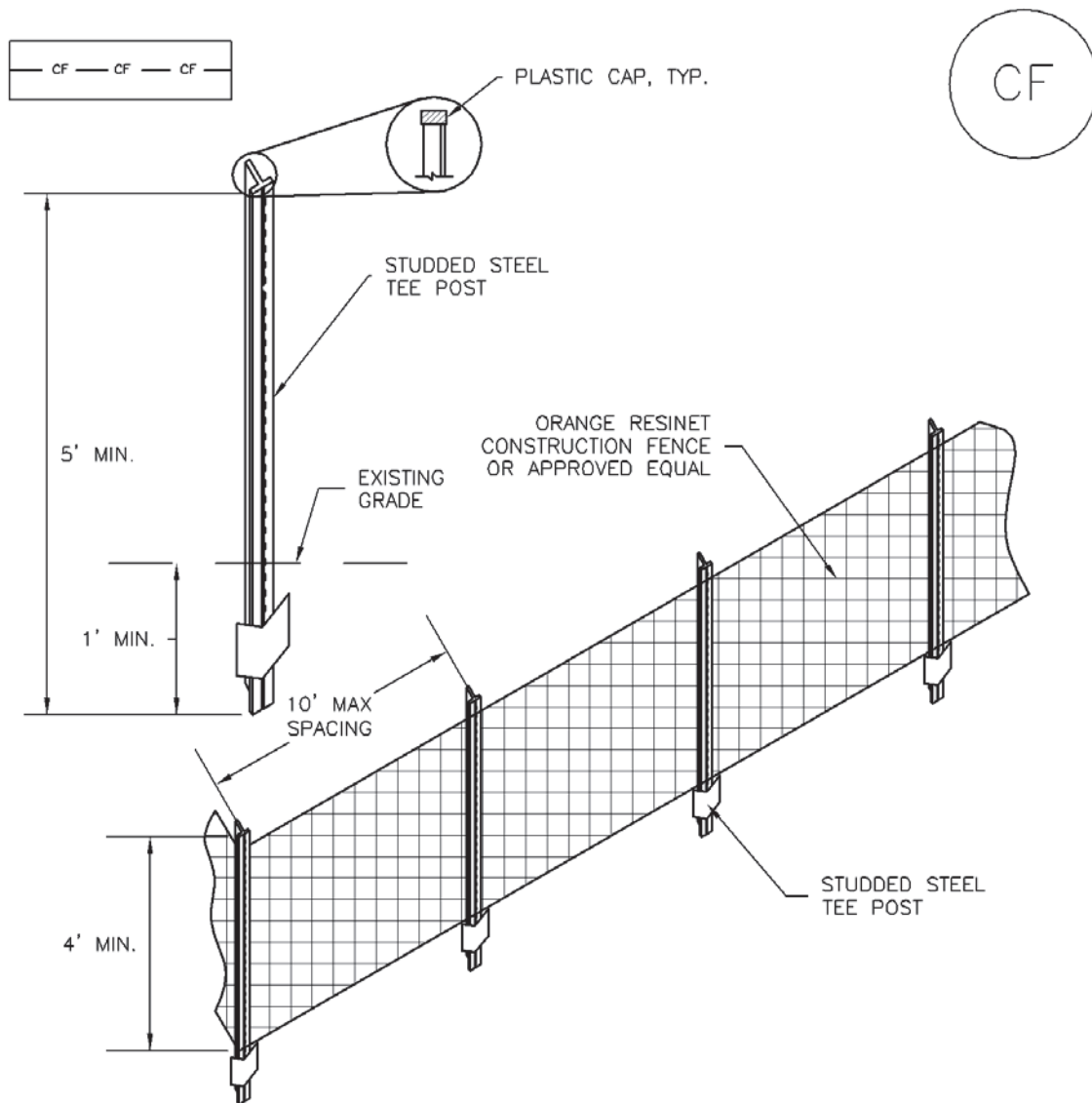

CF-1. PLASTIC MESH CONSTRUCTION FENCE

CONSTRUCTION FENCE INSTALLATION NOTES

1. SEE PLAN VIEW FOR:
-LOCATION OF CONSTRUCTION FENCE.
2. CONSTRUCTION FENCE SHOWN SHALL BE INSTALLED PRIOR TO ANY LAND DISTURBING ACTIVITIES.
3. CONSTRUCTION FENCE SHALL BE COMPOSED OF ORANGE, CONTRACTOR-GRADE MATERIAL THAT IS AT LEAST 4' HIGH. METAL POSTS SHOULD HAVE A PLASTIC CAP FOR SAFETY.
4. STUDED STEEL TEE POSTS SHALL BE UTILIZED TO SUPPORT THE CONSTRUCTION FENCE. MAXIMUM SPACING FOR STEEL TEE POSTS SHALL BE 10'.
5. CONSTRUCTION FENCE SHALL BE SECURELY FASTENED TO THE TOP, MIDDLE, AND BOTTOM OF EACH POST.

CONSTRUCTION FENCE MAINTENANCE NOTES

1. INSPECT BMPs EACH WORKDAY, AND MAINTAIN THEM IN EFFECTIVE OPERATING CONDITION. MAINTENANCE OF BMPs SHOULD BE PROACTIVE, NOT REACTIVE. INSPECT BMPs AS SOON AS POSSIBLE (AND ALWAYS WITHIN 24 HOURS) FOLLOWING A STORM THAT CAUSES SURFACE EROSION, AND PERFORM NECESSARY MAINTENANCE.
2. FREQUENT OBSERVATIONS AND MAINTENANCE ARE NECESSARY TO MAINTAIN BMPs IN EFFECTIVE OPERATING CONDITION. INSPECTIONS AND CORRECTIVE MEASURES SHOULD BE DOCUMENTED THOROUGHLY.
3. WHERE BMPs HAVE FAILED, REPAIR OR REPLACEMENT SHOULD BE INITIATED UPON DISCOVERY OF THE FAILURE.
4. CONSTRUCTION FENCE SHALL BE REPAIRED OR REPLACED WHEN THERE ARE SIGNS OF DAMAGE SUCH AS RIPS OR SAGS. CONSTRUCTION FENCE IS TO REMAIN IN PLACE UNTIL THE UPSTREAM DISTURBED AREA IS STABILIZED AND APPROVED BY THE LOCAL JURISDICTION.
5. WHEN CONSTRUCTION FENCES ARE REMOVED, ALL DISTURBED AREAS ASSOCIATED WITH THE INSTALLATION, MAINTENANCE, AND/OR REMOVAL OF THE FENCE SHALL BE COVERED WITH TOPSOIL, SEEDED AND MULCHED, OR OTHERWISE STABILIZED AS APPROVED BY LOCAL JURISDICTION.

NOTE: MANY JURISDICTIONS HAVE BMP DETAILS THAT VARY FROM UDFCD STANDARD DETAILS. CONSULT WITH LOCAL JURISDICTIONS AS TO WHICH DETAIL SHOULD BE USED WHEN DIFFERENCES ARE NOTED.

(DETAIL ADAPTED FROM TOWN OF PARKER, COLORADO, NOT AVAILABLE IN AUTOCAD)

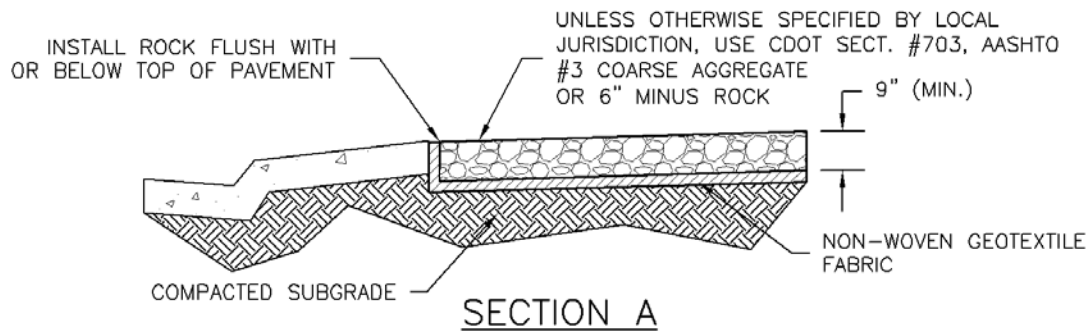
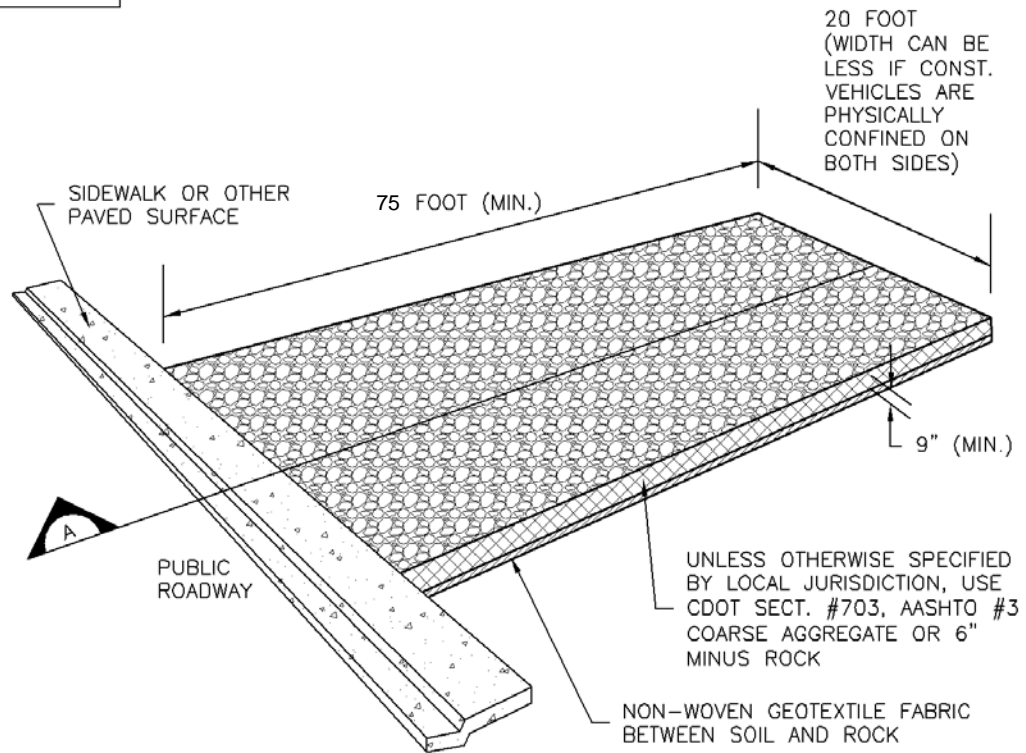
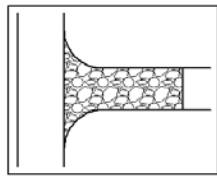

VTC-1. AGGREGATE VEHICLE TRACKING CONTROL

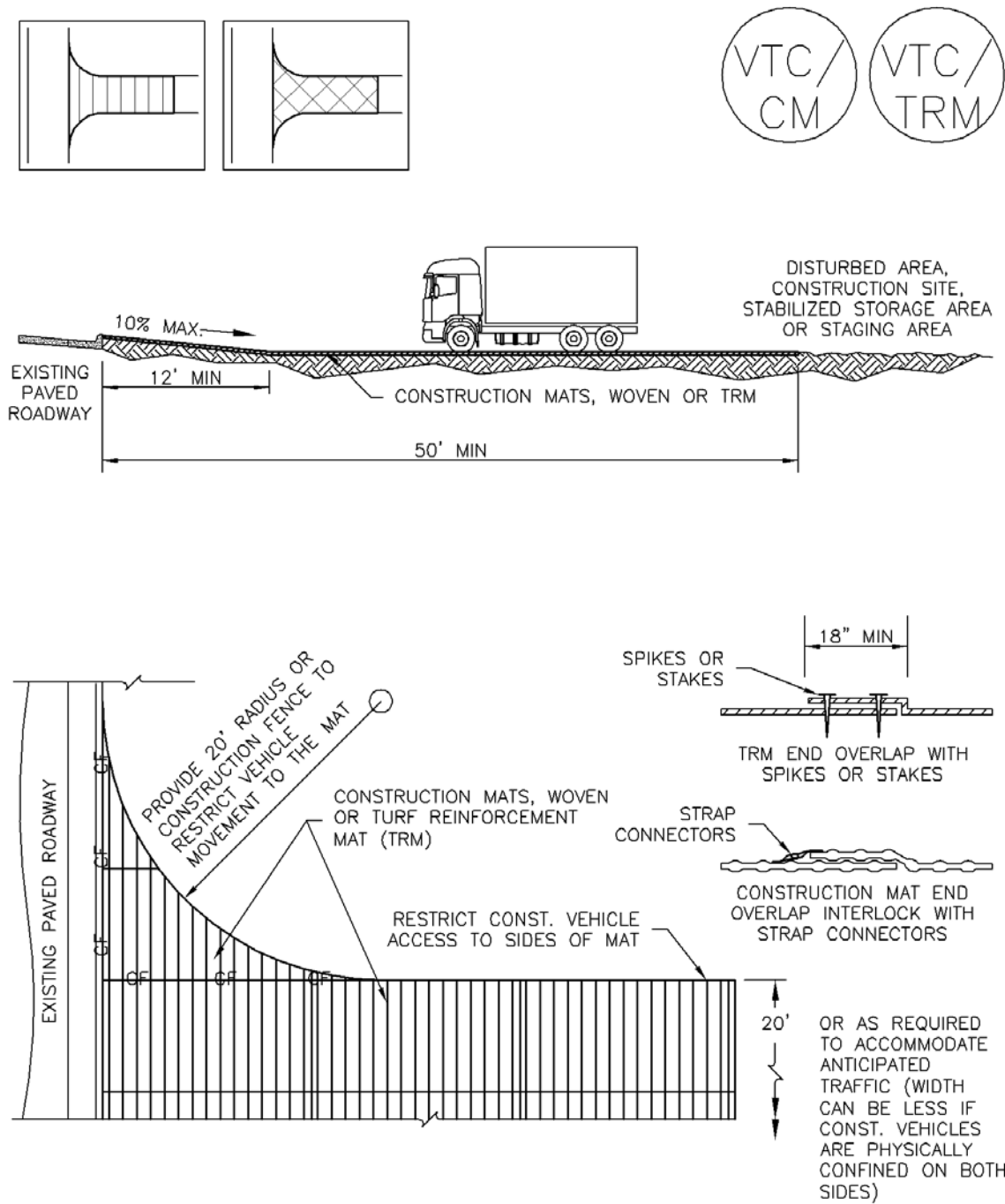

VTC-3. VEHICLE TRACKING CONTROL W/ CONSTRUCTION MAT OR TURF REINFORCEMENT MAT (TRM)

STABILIZED CONSTRUCTION ENTRANCE/EXIT INSTALLATION NOTES

1. SEE PLAN VIEW FOR
 - LOCATION OF CONSTRUCTION ENTRANCE(S)/EXIT(S).
 - TYPE OF CONSTRUCTION ENTRANCE(S)/EXITS(S) (WITH/WITHOUT WHEEL WASH, CONSTRUCTION MAT OR TRM).
2. CONSTRUCTION MAT OR TRM STABILIZED CONSTRUCTION ENTRANCES ARE ONLY TO BE USED ON SHORT DURATION PROJECTS (TYPICALLY RANGING FROM A WEEK TO A MONTH) WHERE THERE WILL BE LIMITED VEHICULAR ACCESS.
3. A STABILIZED CONSTRUCTION ENTRANCE/EXIT SHALL BE LOCATED AT ALL ACCESS POINTS WHERE VEHICLES ACCESS THE CONSTRUCTION SITE FROM PAVED RIGHT-OF-WAYS.
4. STABILIZED CONSTRUCTION ENTRANCE/EXIT SHALL BE INSTALLED PRIOR TO ANY LAND DISTURBING ACTIVITIES.
5. A NON-WOVEN GEOTEXTILE FABRIC SHALL BE PLACED UNDER THE STABILIZED CONSTRUCTION ENTRANCE/EXIT PRIOR TO THE PLACEMENT OF ROCK.
6. UNLESS OTHERWISE SPECIFIED BY LOCAL JURISDICTION, ROCK SHALL CONSIST OF DOT SECT. #703, AASHTO #3 COARSE AGGREGATE OR 6" (MINUS) ROCK.

STABILIZED CONSTRUCTION ENTRANCE/EXIT MAINTENANCE NOTES

1. INSPECT BMPs EACH WORKDAY, AND MAINTAIN THEM IN EFFECTIVE OPERATING CONDITION. MAINTENANCE OF BMPs SHOULD BE PROACTIVE, NOT REACTIVE. INSPECT BMPs AS SOON AS POSSIBLE (AND ALWAYS WITHIN 24 HOURS) FOLLOWING A STORM THAT CAUSES SURFACE EROSION, AND PERFORM NECESSARY MAINTENANCE.
2. FREQUENT OBSERVATIONS AND MAINTENANCE ARE NECESSARY TO MAINTAIN BMPs IN EFFECTIVE OPERATING CONDITION. INSPECTIONS AND CORRECTIVE MEASURES SHOULD BE DOCUMENTED THOROUGHLY.
3. WHERE BMPs HAVE FAILED, REPAIR OR REPLACEMENT SHOULD BE INITIATED UPON DISCOVERY OF THE FAILURE.
4. ROCK SHALL BE REAPPLIED OR REGRADED AS NECESSARY TO THE STABILIZED ENTRANCE/EXIT TO MAINTAIN A CONSISTENT DEPTH.
5. SEDIMENT TRACKED ONTO PAVED ROADS IS TO BE REMOVED THROUGHOUT THE DAY AND AT THE END OF THE DAY BY SHOVELING OR SWEEPING. SEDIMENT MAY NOT BE WASHED DOWN STORM SEWER DRAINS.

NOTE: MANY JURISDICTIONS HAVE BMP DETAILS THAT VARY FROM UDFCD STANDARD DETAILS. CONSULT WITH LOCAL JURISDICTIONS AS TO WHICH DETAIL SHOULD BE USED WHEN DIFFERENCES ARE NOTED.

(DETAILS ADAPTED FROM CITY OF BROOMFIELD, COLORADO, NOT AVAILABLE IN AUTOCAD)

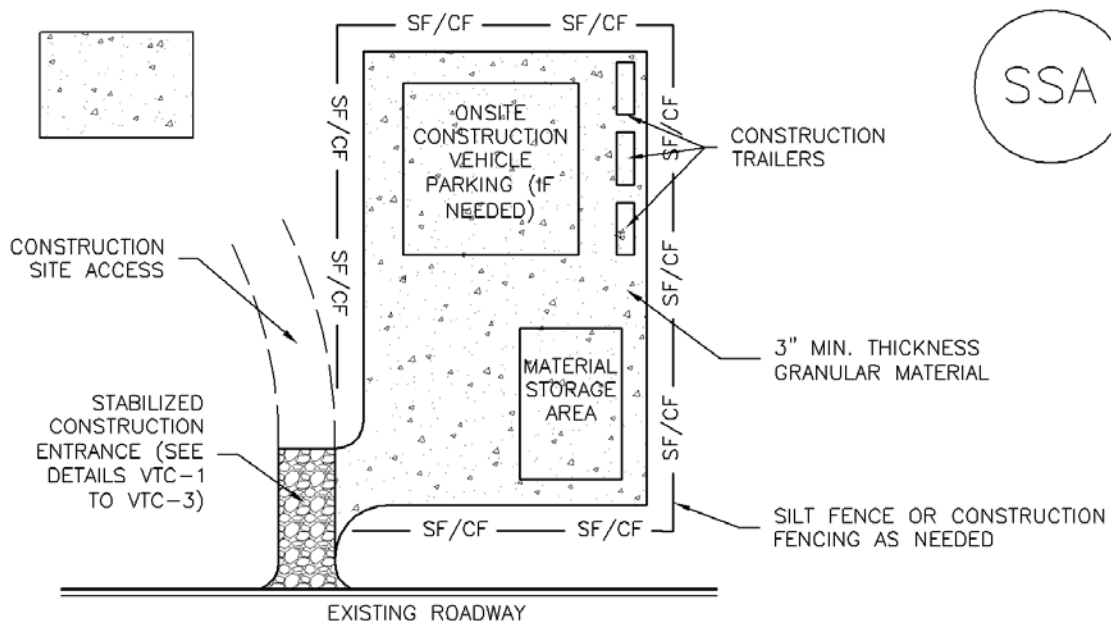

SSA-1. STABILIZED STAGING AREA

STABILIZED STAGING AREA INSTALLATION NOTES

1. SEE PLAN VIEW FOR
 - LOCATION OF STAGING AREA(S).
 - CONTRACTOR MAY ADJUST LOCATION AND SIZE OF STAGING AREA WITH APPROVAL FROM THE LOCAL JURISDICTION.
2. STABILIZED STAGING AREA SHOULD BE APPROPRIATE FOR THE NEEDS OF THE SITE. OVERSIZING RESULTS IN A LARGER AREA TO STABILIZE FOLLOWING CONSTRUCTION.
3. STAGING AREA SHALL BE STABILIZED PRIOR TO OTHER OPERATIONS ON THE SITE.
4. THE STABILIZED STAGING AREA SHALL CONSIST OF A MINIMUM 3" THICK GRANULAR MATERIAL.
5. UNLESS OTHERWISE SPECIFIED BY LOCAL JURISDICTION, ROCK SHALL CONSIST OF DOT SECT. #703, AASHTO #3 COARSE AGGREGATE OR 6" (MINUS) ROCK.
6. ADDITIONAL PERIMETER BMPs MAY BE REQUIRED INCLUDING BUT NOT LIMITED TO SILT FENCE AND CONSTRUCTION FENCING.

STABILIZED STAGING AREA MAINTENANCE NOTES

1. INSPECT BMPs EACH WORKDAY, AND MAINTAIN THEM IN EFFECTIVE OPERATING CONDITION. MAINTENANCE OF BMPs SHOULD BE PROACTIVE, NOT REACTIVE. INSPECT BMPs AS SOON AS POSSIBLE (AND ALWAYS WITHIN 24 HOURS) FOLLOWING A STORM THAT CAUSES SURFACE EROSION, AND PERFORM NECESSARY MAINTENANCE.
2. FREQUENT OBSERVATIONS AND MAINTENANCE ARE NECESSARY TO MAINTAIN BMPs IN EFFECTIVE OPERATING CONDITION. INSPECTIONS AND CORRECTIVE MEASURES SHOULD BE DOCUMENTED THOROUGHLY.
3. WHERE BMPs HAVE FAILED, REPAIR OR REPLACEMENT SHOULD BE INITIATED UPON DISCOVERY OF THE FAILURE.
4. ROCK SHALL BE REAPPLIED OR REGRADED AS NECESSARY IF RUTTING OCCURS OR UNDERLYING SUBGRADE BECOMES EXPOSED.

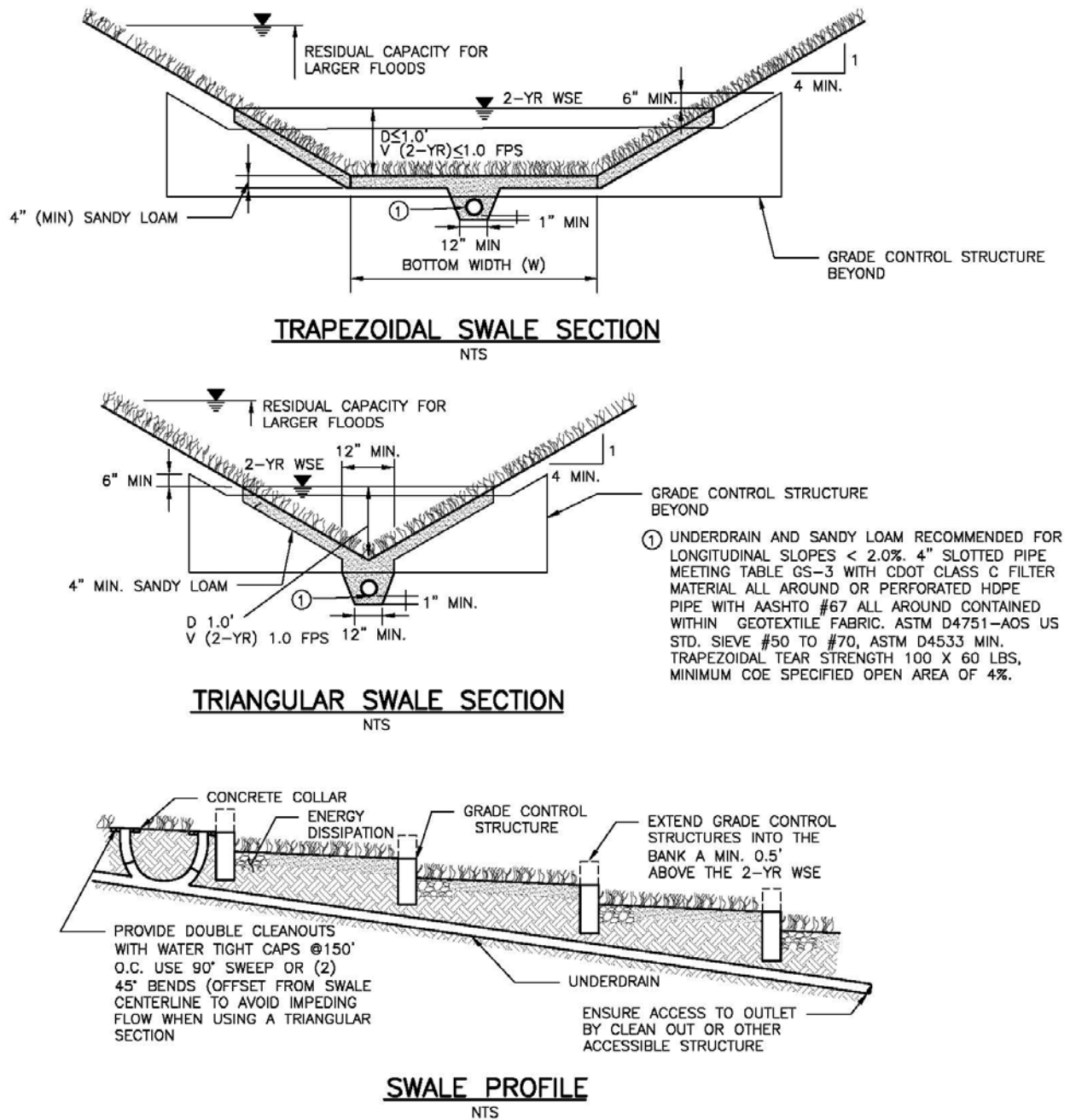

Figure GS-1. Grass Swale Profile and Sections

Design Example

The *UD-BMP* workbook, designed as a tool for both designer and reviewing agency is available at www.udfcd.org. This section provides a completed design form from this workbook as an example.

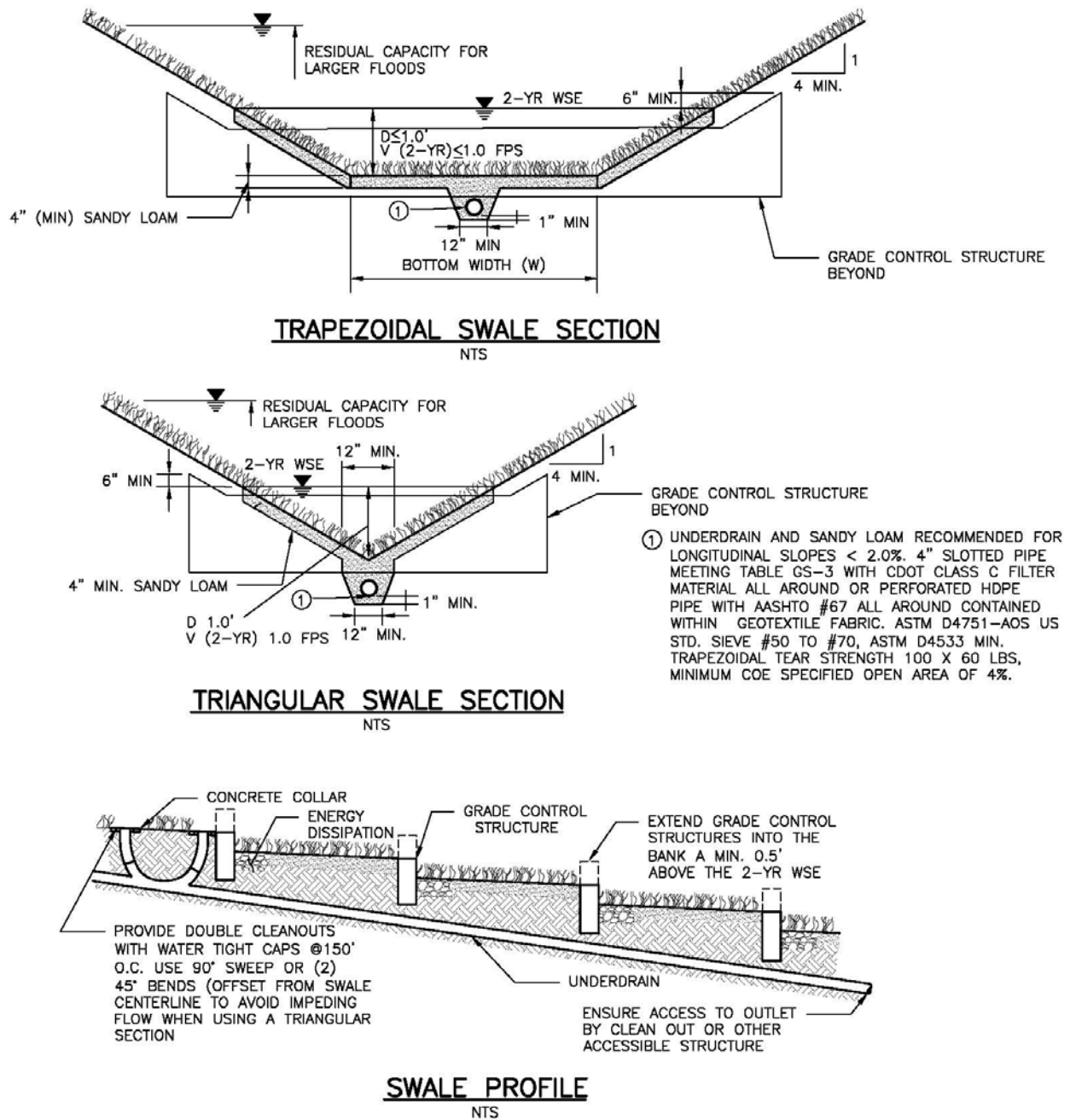

Figure GS-1. Grass Swale Profile and Sections

Design Example

The *UD-BMP* workbook, designed as a tool for both designer and reviewing agency is available at www.udfcd.org. This section provides a completed design form from this workbook as an example.

FLOW
↓

Ø REMOVE ACCUMULATED SEDIMENT WHEN IT REACHES ONE HALF OF EXPOSED LOG HEIGHT. INSPECTIONS SHALL BE PERFORMED FREQUENTLY FOR PROPER FUNCTION.

EROSION LOGS SHOULD BE KEYED IN TO PREVENT UNDER-CUTTING

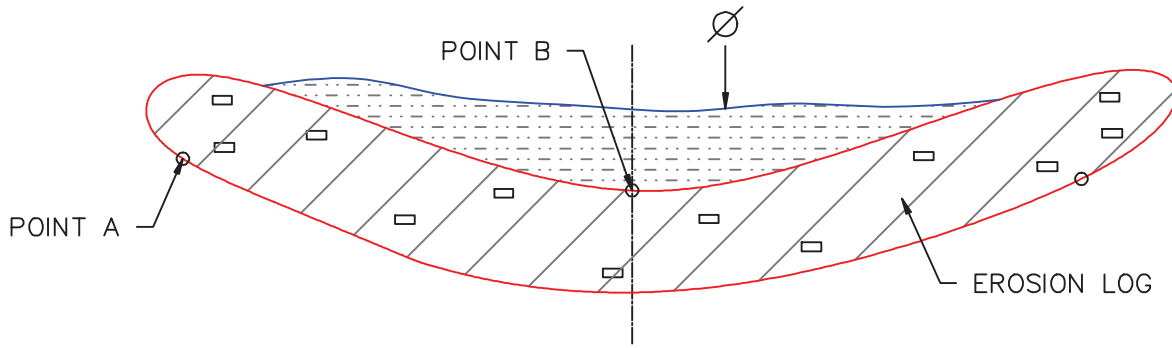

PLAN VIEW

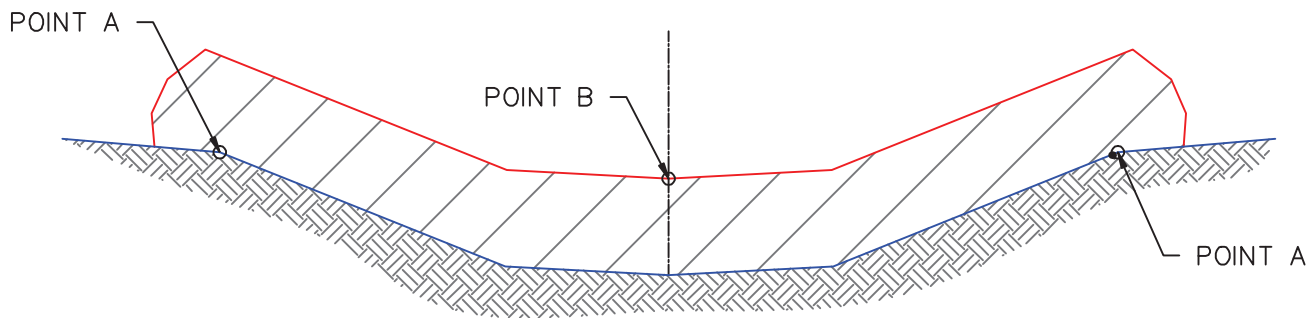

POINTS A SHALL BE HIGHER THAN POINT B

ELEVATION

EROSION LOG DETAIL DITCH INSTALLATION

NOTE: EROSION LOGS SHALL BE TIGHTLY ABUTTED WITH NO GAPS.

1/1/08

DATE APPROVED:

John A. McCarty

DEPARTMENT OF TRANSPORTATION

Erosion Log Check Dams

Standard Drawing

REVISION DATE:

7/17/07

FILE NAME:

SD_3-85



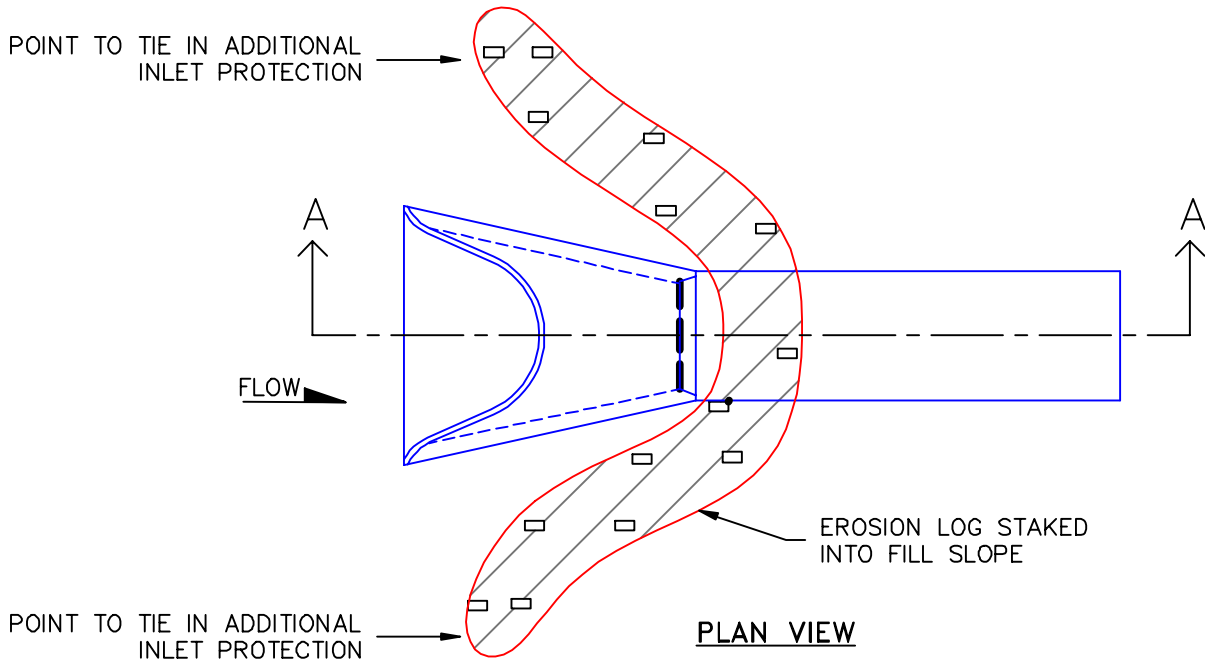

NOTE:

Ø REMOVE ACCUMULATED SEDIMENT WHEN IT REACHES ONE HALF OF EXPOSED LOG HEIGHT. INSPECTIONS SHALL BE PERFORMED FREQUENTLY FOR PROPER FUNCTION.

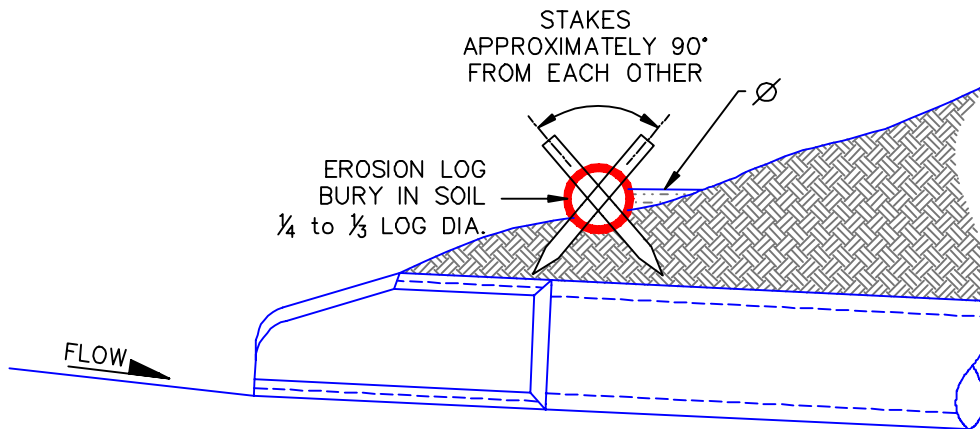

SECTION A-A

EROSION PROTECTION ABOVE CULVERT OUTLETS IS SIMILAR

EROSION LOGS SHOULD BE KEYED IN TO PREVENT UNDER-CUTTING

<p>1/1/08</p> <p>DATE APPROVED:</p> <p>John A. McCarty</p> <p>DEPARTMENT OF TRANSPORTATION</p>	<p>Culvert Inlet and Outlet Protection Erosion Logs Above Inlets and Outlets For Slopes 3:1 or Steeper</p> <p>Standard Drawing</p> <p>REVISION DATE: 7/17/07</p> <p>FILE NAME: SD_3-86</p>	
--	--	---

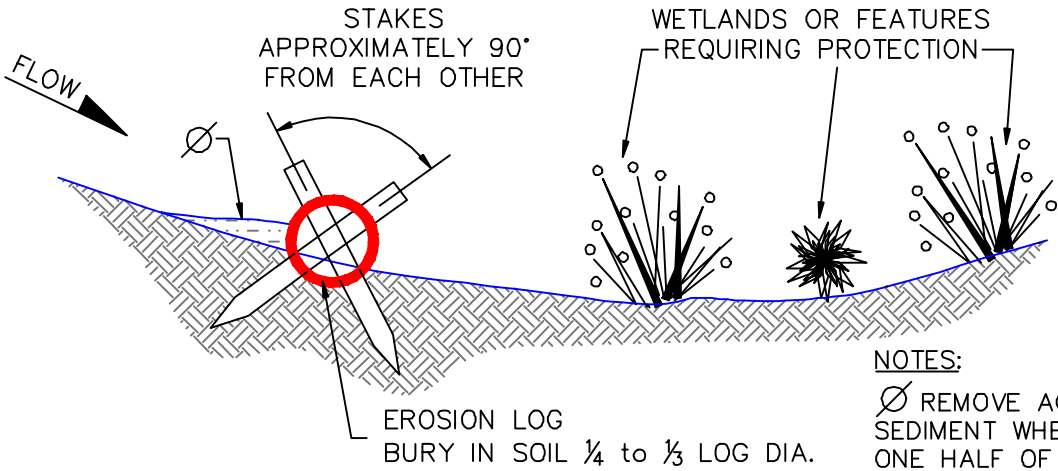

SECTION A-A
EROSION LOG APPLICATION

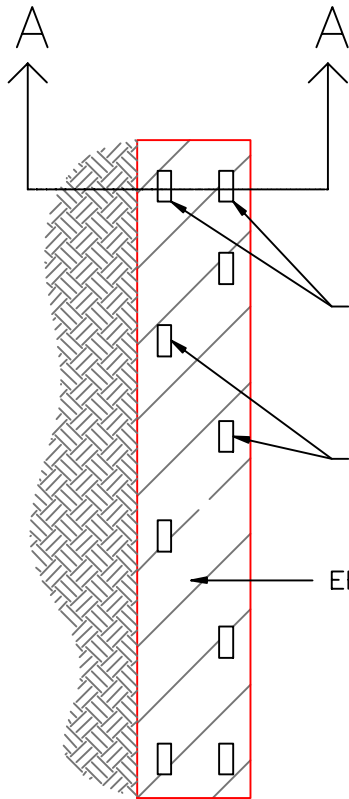

TYPICAL STAKE INSTALLATION

EROSION LOGS CAN ALSO BE USED ACROSS LONG SLOPES TO REDUCE EROSION AND SEDIMENT MOVEMENT

<p>1/1/08</p> <p>DATE APPROVED:</p> <p>John A. McCarty</p> <p>DEPARTMENT OF TRANSPORTATION</p>	<p>Erosion Log Barrier</p> <p>Standard Drawing</p> <p>REVISION DATE: 7/17/07</p> <p>FILE NAME: SD_3-87</p>	
--	--	---

APPENDIX F

EROSION AND STORMWATER QUALITY CONTROL PERMIT (ESQCP) EL PASO COUNTY APPLICATION AND PERMIT

APPLICANT INFORMATION

PERMIT NUMBER

Owner Information	
Owner	Challenger Communities, LLC – <i>Additional Owners attached</i>
Name (person of responsibility)	Jim Byers
Company/Agency	Challenger Communities, Inc.
Position of Applicant	VP of Community Development
Address (physical address, not PO Box)	8605 Explorer Dr, Suite 250
City	Colorado Springs
State	CO
Zip Code	80920
Mailing address, if different from above	Same as above
Telephone	719-598-5192 ext 248
FAX number	
Email Address	Jim@Challengerhomes.com
Cellular Phone number	719-440-0592
Contractor/Operator Information	
Name (person of responsibility)	
Company	
Address (physical address, not PO Box)	
City	
State	
Zip Code	
Mailing address, if different from above	
Telephone	
FAX number	
Email Address	
Cellular Phone number	
Erosion Control Supervisor (ECS)*	
ECS Phone number*	
ECS Cellular Phone number*	

*Required for all applicants. May be provided at later date pending securing a contract when applicable.

PROJECT INFORMATION

Project Information	
Project Name	Falcon Meadows at Bent Grass Channel Improvements
Legal Description	Falcon Meadows at Bent Grass
Address (or nearest major cross streets)	Bent Grass Meadows Drive and Meridian Road
Acreage (total and disturbed)	Total: 16.4 acres Disturbed: 16.4 acres
Schedule	Start of Construction: May 2022 Completion of Construction: December 2022 Final Stabilization: Spring 2023
Project Purpose	Installation of supporting infrastructure for channel improvements in the Falcon Basin West Tributary, north of Woodmen Road.
Description of Project	Falcon Meadows at Bent Grass channel improvements for Falcon Basin West Tributary, north of Woodmen Road
Tax Schedule Number	53012-01-062, 53012-04-006, 53010-00-016, and 53010-00-017

FOR OFFICE USE ONLY

The following signature from the ECM Administrator signifies the approval of this ESQCP. All work shall be performed in accordance with the permit, the El Paso County Engineering Criteria Manual (ECM) Standards, City of Colorado Springs Drainage Criteria Manual, Volume 2 (DCM2) as adopted by El Paso County Addendum, approved plans, and any attached conditions. The approved plans are an enforceable part of the ESQCP. Construction activity, except for the installation of initial construction BMPs is not permitted until issuance of a Construction permit and Notice to Proceed.

Signature of ECM Administrator: _____

Date _____

1.1 REQUIRED SUBMISSIONS

In addition to this completed and signed application, the following items must be submitted to obtain an ESQCP:

- Permit fees
- Stormwater Management Plan (SWMP) meeting the requirements of DCM2 and ECM either as part of the plan set or as a separate document;
- Cost estimates of construction and maintenance of construction and permanent stormwater control measures (Cost estimates shall be provided on a unit cost basis for all stormwater BMPs);
- Financial surety in an amount agreeable to the ECM Administrator based on the cost estimates of the stormwater quality protection measures provided. The financial surety shall be provided in the form of a Letter of Credit, Surety with a Bonding Company, or other forms acceptable to El Paso County;
- Operation and Maintenance Plan for any proposed permanent stormwater control measures; and
- Signed Private Detention Basin/Stormwater Quality Best Management Practice Maintenance Agreement and Easement, if any permanent stormwater control measures are to be located on site.

1.2 RESPONSIBILITY FOR DAMAGE

The County and its officers and employees, including but not limited to the ECM Administrator, shall not be answerable or accountable in any manner, for injury to or death of any person, including but not limited to a permit holder, persons employed by the permit holder, persons acting in behalf of the permit holder, or for damage to property resulting from any activities undertaken by a permit holder or under the direction of a permit holder. The permit holder shall be responsible for any liability imposed by law and for injuries to or death of any person, including but not limited to the permit holder, persons employed by the permit holder, persons acting in behalf of the permit holder, or damage to property arising out of work or other activity permitted and done by the permit holder under a permit, or arising out of the failure on the permit holder's part to perform the obligations under any permit in respect to maintenance or any other obligations, or resulting from defects or obstructions, or from any cause whatsoever during the progress of the work, or other activity, or at any subsequent time work or other activity is being performed under the obligations provided by and contemplated by the permit.

To the extent allowed by law, the permit holder shall indemnify, save, and hold harmless the County and its officers and employees, including but not limited to the BOCC and ECM Administrator, from all claims, suits or actions of every name, kind and description brought for or on account of injuries to or death of any person, including but not limited to the permit holder, persons employed by the permit holder, persons acting in behalf of the permit holder and the public, or damage to property resulting from the performance of work or other activity under the permit, or arising out of the failure on the permit holder's part to perform his obligations under any permit in respect to maintenance or any other obligations, or resulting from defects or obstructions, or from any cause whatsoever during the progress of the work, or other activity or at any subsequent time work or other activity is being performed under the obligations provided by and contemplated by the permit, except as otherwise provided by state law. The permit holder waives any and all rights to any type of expressed or implied indemnity against the County, its officers or employees.

1.3 APPLICATION CERTIFICATION

We, as the Applicants or the representative of the Applicants, hereby certify that this application is correct and complete as per the requirements presented in this application and the El Paso County Engineering Criteria Manual and Drainage Criteria Manual, Volume 2 and El Paso County Addendum.

We, as the Applicants or the representatives of the Applicants, have read and will comply with all of the requirements of the specified Stormwater Management Plan and any other documents specifying stormwater best management practices to be used on the site including permit conditions that may be required by the ECM Administrator. We understand that the stormwater control measures are to be maintained on the site and revised as necessary to protect stormwater quality as the project progresses. We further understand that a Construction Permit must be obtained and all necessary stormwater quality control measures are to be installed in accordance with the SWMP, the El Paso County Engineering Criteria Manual, Drainage Criteria Manual, Volume 2 and El Paso County Addendum before land disturbance begins and that failure to comply will result in a Stop Work Order and may result in other penalties as allowed by law. We further understand and agree to indemnify, save, and hold harmless the County and its officers and employees, including but not limited to the BOCC and ECM Administrator, from all claims, suits or actions of every name, kind and description as outlined in Section 1.2 Responsibility for Damage.

Signature of Owner or Representative

Date: _____

Print Name of Owner or Representative

Signature of Owner or Representative

Date: _____

Print Name of Owner or Representative

Signature of Operator or Representative

Date: _____

Print Name of Operator or Representative

Permit Fee \$ _____

Surcharge \$ _____

Financial Surety \$ _____

Type of Surety _____

Total \$ _____

Additional Owner Information

Property #2

Owner	Lena Gail Case
Name (Person of responsibility)	Lena Gail Case
Company/Agency	
Position of Applicant	
Address (physical address, not PO Box)	53010-00-017 (Tax Schedule #)
City	Colorado Springs
State	CO
Zip Code	80920
Mailing Address, if different from above	119 N. Wahsatch Ave
Telephone	
FAX Number	
Email Address	
Cellular Phone Number	

Property #3

Owner	Randy DeYoung
Name (Person of responsibility)	Randy DeYoung
Company/Agency	
Position of Applicant	
Address (physical address, not PO Box)	53010-00-016 (Tax Schedule #)
City	Colorado Springs
State	CO
Zip Code	80920
Mailing Address, if different from above	10925 E. Highway 24, Peyton CO, 80831
Telephone	
FAX Number	
Email Address	
Cellular Phone Number	