



**ENTECH**  
ENGINEERING, INC.

505 ELKTON DRIVE  
COLORADO SPRINGS, CO 80907  
PHONE (719) 531-5599  
FAX (719) 531-5238

**SOIL, GEOLOGY, GEOLOGIC HAZARD,  
AND WASTEWATER STUDY,  
SETTLERS VIEW SUBDIVISION  
STEPPLER ROAD AND HODGEN ROAD  
EL PASO COUNTY, COLORADO**

Prepared for

**Jerome Hannigan and Associates, INC.**  
19360 Spring Valley Road  
Monument, Colorado 80132

Attn: Jerry Hannigan

February 2, 2017

Respectfully Submitted,

ENTECH ENGINEERING, INC.

Logan L. Langford  
Geologist

LLL/rm

Encl.

Entech Job No. 162442  
AAprojects/2016/162442countysoil/geo/ww

Reviewed by:

Joseph C. Goode, P.E.  
President

JOSEPH COLLIN GOODE  
23725  
2-2-17  
PROFESSIONAL ENGINEER  
COLORADO LICENSED

**TABLE OF CONTENTS**

1.0 SUMMARY ..... 1  
2.0 GENERAL SITE CONDITIONS AND PROJECT DESCRIPTION ..... 2  
3.0 SCOPE OF THE REPORT ..... 2  
4.0 FIELD INVESTIGATION ..... 3  
5.0 SOIL, GEOLOGY AND ENGINEERING GEOLOGY ..... 4  
    5.1 General Geology ..... 4  
    5.2 Soil Conservation Survey ..... 4  
    5.3 Site Stratigraphy ..... 5  
    5.4 Soil Conditions ..... 5  
    5.5 Groundwater ..... 6  
6.0 ENGINEERING GEOLOGY – IDENTIFICATION AND MITIGATION OF GEOLOGIC HAZARDS ..... 7  
    6.1 Relevance of Geologic Conditions to Land Use Planning ..... 9  
7.0 ON-SITE DISPOSAL OF WASTEWATER ..... 10  
8.0 ECONOMIC MINERAL RESOURCES ..... 12  
9.0 EROSION CONTROL ..... 13  
10.0 CLOSURE ..... 14  
BIBLIOGRAPHY ..... 15

**TABLES**

- Table 1: Summary of Laboratory Test Results
- Table 2: Summary of Percolation Test Results

**FIGURES**

- Figure 1: Vicinity Map
- Figure 2: USGS Map
- Figure 3: Development Plan/Test Boring Location Map
- Figure 4: Soil Survey Map
- Figure 5: Black Forest Quadrangle Geology Map
- Figure 6: Geology Map/Engineering Geology
- Figure 7: Typical Perimeter Drain Details
- Figure 8: Floodplain Map
- Figure 9: Septic Suitability Map

- APPENDIX A: Site Photographs
- APPENDIX B: Test Boring Logs and Profile Hole Logs
- APPENDIX C: Laboratory Test Results
- APPENDIX D: Soil Survey Descriptions
- APPENDIX E: Percolation Test Results

## **1.0 SUMMARY**

### ***Project Location***

The project lies in a portion of the NE ¼ of Section 23, Township 11 South, Range 66 West of the 6<sup>th</sup> Principal Meridian in El Paso County, Colorado. The site is located approximately 5½ miles east of Monument, Colorado.

### ***Project Description***

Total acreage involved in the project is approximately 40 acres. The proposed site development consists of fourteen single-family rural residential lots. The development will utilize individual wells and on-site wastewater treatment systems.

### ***Scope of Report***

This report presents the results of our geologic evaluation, treatment of engineering geologic hazard study and wastewater study for individual on-site wastewater treatment systems.

### ***Land Use and Engineering Geology***

This site was found to be suitable for the proposed development. Areas were encountered where the geologic conditions will impose some minor constraints on development and land use. These include areas of shallow groundwater areas, seasonal shallow groundwater areas, drainage areas and erosion areas. Based on the proposed development plan, it appears that these areas will have some impact on the development. These conditions will be discussed in greater detail in the report.

In general, it is our opinion that the development can be achieved if the observed geologic conditions on site are either avoided or properly mitigated. All recommendations are subject to the limitations discussed in the report.

## **2.0 GENERAL SITE CONDITIONS AND PROJECT DESCRIPTION**

The site is located in a portion of the NE ¼ of Section 23, Township 11 South, Range 66 West of the 6<sup>th</sup> Principal Meridian in El Paso County, Colorado. The site is located approximately 5½ miles east of Monument, Colorado, on Stepler Road, north of Hodgen Road. The location of the site is as shown on the Vicinity Map, Figure 1.

The topography of the site varies from gently to moderately sloping generally to the west, and to gently sloping to the northeast in the northeastern portion of site. A small ridge is located in the eastern portion of the site. The drainages on site flow in westerly direction through the southwest portion of the site. Water was not observed flowing in drainage at the time of this investigation. The site boundaries are indicated on the USGS Map, Figure 2. An existing house is present on Lot 2, and an existing driveway located Lot 14. Previous land uses have included grazing and pasture land. The site contains primarily field grasses and weeds with areas of ponderosa pines in the northwestern portion of the site. Site photographs, taken December 15, 2016, are included in Appendix A.

Total acreage involved in the proposed development is approximately 40 acres. Fourteen single-family rural residential lots are proposed. Existing structures exist on two of the lots. The proposed lots are approximately 2½ to 3 acres each. The area will be serviced by individual wells and on-site wastewater treatment systems. The proposed Development Plan is presented in Figure 3.

## **3.0 SCOPE OF THE REPORT**

The scope of the report will include the following:

- A general geologic analysis utilizing published geologic data. Detailed site-specific mapping will be conducted to obtain general information in respect to major geographic and geologic features, geologic descriptions and their effects on the development of the property.
- The site will be evaluated for individual on-site wastewater treatment systems in accordance with El Paso Land Development Code.

## **4.0 FIELD INVESTIGATION**

Our field investigation consisted of the preparation of a geologic map of any bedrock features and significant surficial deposits. The Natural Resource Conservation Service (NRCS), previously the Soil Conservation Service (SCS) survey was also reviewed to evaluate the site. The position of mappable units within the subject property are shown on the Geologic Map. Our mapping procedures involved both field reconnaissance and measurements and air photo reconnaissance and interpretation. The same mapping procedures have also been utilized to produce the Engineering Geology Map which identified pertinent geologic conditions affecting development. The field mapping was performed by personnel of Entech Engineering, Inc. on Decemeber 15, 2016.

Three (3) percolation tests, and three (3) tactile test pits were performed on the site to determine general suitability of the site for the use of on-site wastewater treatment systems. The locations of the percolation tests profile borings, and test pits are indicated on the Development Plan/Test Boring Location Map, Figure 3. The Profile Hole and Test Pit Logs are presented in Appendix B. Results of this testing will be discussed later in this report.

Laboratory testing was also performed on some of the soils to classify and determine the soils engineering characteristics. Laboratory tests included grain-size analysis, ASTM D-422, and Atterberg Limits, ASTM D-4318. Volume change testing was performed on selected samples using Swell/Consolidation Tests in order to evaluate potential expansion/compression characteristics of the soil. Soils sampled from the tactile test pits were classified using the USDA Textural Soil Classification. Results of the laboratory testing are included in Appendix C. A Summary of Laboratory Test Results is presented in Table 1.

## 5.0 SOIL, GEOLOGY AND ENGINEERING GEOLOGY

### 5.1 General Geology

Physiographically, the site lies in the western portion of the Great Plains Physiographic Province. Approximately 9 miles to the west is a major structural feature known as the Rampart Range Fault. This fault marks the boundary between the Great Plains Physiographic Province and the Southern Rocky Mountain Province. The site exists within the southeastern edge of a large structural feature known as the Denver Basin. Bedrock in the area tends to be very gently dipping in a northeasterly direction (Reference 1). The rocks in the area of the site are sedimentary in nature and typically Tertiary to Upper Cretaceous in age. The bedrock underlying the site consists of the Dawson Arkose Formation. Overlying this formation are unconsolidated deposits of residual, man-made, and alluvial soils of the Quaternary to Tertiary Age. The residual soils are produced by the in-situ action of weathering of the bedrock on site. The alluvial soils were deposited by water in the major drainages on site and as stream terraces on some of the ridge lines. Man-made soils exist as earthen dams. The site's stratigraphy will be discussed in more detail in Section 5.3.

### 5.2 Soil Conservation Survey

The Natural Resource Conservation Service (Reference 2), previously the Soil Conservation Service (Reference 3) has mapped three soil types on the site (Figure 4). In general, they vary from sandy loam to loamy sand. The soils are described as follows:

<u>Type</u>	<u>Description</u>
25	Elbeth Sandy Loam, 3-8% slopes
67	Peyton Sandy Loam, 5-9% slopes
92	Tomah-Crowfoot Loamy Sand, 3-8% slopes

Complete descriptions of the soil type are presented in Appendix D. The soils have generally been described to have moderate to moderately rapid permeabilities. Limitations on development include the drainages where frost action potential exist. Roads may need to be designed to minimize frost-heave potential. Possible hazards with soil erosion are present on

the site. The erosion potential can be controlled with vegetation. The soils have been described to have slight to moderate erosion hazards.

### 5.3 Site Stratigraphy

The Black Forest Quadrangle Geology Map showing the site is presented in Figure 5 (Reference 4). The Geology Map prepared for the site is presented in Figure 6. Two mappable units were identified on this site which are described as follows:

**Qal Recent Alluvium of Holocene Age:** These are recent deposits that have been deposited along the drainages that exist on-site. These materials typically consist of silty to clayey sands and sandy clays. Some of these alluviums contain highly organic soils.

**Tkd Dawson Formation of Tertiary to Cretaceous Age:** The Dawson formation typically consists of arkosic sandstone with interbedded fine-grained sandstone, siltstone and claystone. Overlying this formation is a variable layer of residual soil. The residual soils were derived from the in-situ weathering of the bedrock materials on-site. These soils consisted of silty to clayey sands and sandy clays.

The soils listed above were mapped from site-specific mapping, the *Geologic Map of the Black Forest Quadrangle* distributed by the Colorado Geological Survey in 2003 (Reference 4), the *Geologic Map of the Colorado Springs-Castle Rock Area*, distributed by the US Geological Survey in 1979 (Reference 5), and the *Geologic Map of the Denver 1<sup>0</sup> x 2<sup>0</sup> Quadrangle*, distributed by the US Geological Survey in 1981 (Reference 6). The Percolation Test Profile Holes and Tactile Test Pits were also used in evaluating the site and are included in Appendix B. The Geology Map prepared for the site is presented in Figure 6.

### 5.4 Soil Conditions

The soils encountered in the Profile Holes can be grouped into three general soil and rock types. The profile hole soils were classified using the Unified Soil Classification System (USCS). The soils encountered in the Test Pits can be grouped into two general soil and rock types. The test pit soils were classified using the USDA Textural Soil Classification.

Soil Type 1 is a slightly silty to silty sand and clayey to very clayey sand (SM-SW, SM, SC), encountered in the upper soil profile in profile holes and the test pits. These soils were encountered at loose to medium dense states and at moist conditions. Samples tested had 6 to 49 percent passing the No. 200 Sieve.

Soil Type 2 is a very sandy clay (CL). This material was encountered in Profile Hole No. 1 at 9 feet and extending to approximately 11 feet. The clay was encountered at firm consistencies and moist conditions. The sample tested had 60 percent passing the No. 200 sieve. Swell/Consolidation Tests resulted in a swell of 0.0%. These results indicate the clay soils exhibit a low expansion and consolidation potential.

Soil Type 3 is a silty sandstone (SM). This material was encountered in Profile Hole No. 1 and Test Pit No. 3 at depths ranging from 4 to 11 feet and extended to the termination of the test pit and test boring (8 to 15 feet). The sandstone was encountered at dense to very dense states and moist conditions. The sample tested had 15 percent passing the No. 200 sieve. The silty sandstones are typically non-expansive; however, expansive clayey sandstone and claystone are common in the area.

The Test Boring Logs and the Profile Hole Logs are presented in Appendix B. Laboratory Test Results are presented in Appendix C. A Summary of Laboratory Test Results is presented in Table 1.

### **5.5 Groundwater**

Groundwater was encountered in the Profile Hole No. 1 at a depth of 15 feet, groundwater was not encountered in the other profile holes which were drilled to 15 feet. Signs of seasonally occurring groundwater were not observed in the tactile test pits, which were excavated to depths of 8 feet. Areas of seasonal shallow groundwater and potentially seasonal shallow groundwater have been mapped in low-lying areas and in the drainage on-site. These areas are discussed in the following section. Fluctuation in groundwater conditions may occur due to variations in rainfall and other factors not readily apparent at this time.

It should be noted that in the sandy materials on site, some groundwater conditions might be encountered due to the variability in the soil profile. Isolated sand and gravel layers within the soils, sometimes only a few feet in thickness and width, can carry water in the subsurface.



Groundwater may also flow on top of the underlying bedrock. Builders and planners should be cognizant of the potential for the occurrence of such subsurface water features during construction on-site and deal with each individual problem as necessary at the time of construction.

## **6.0 ENGINEERING GEOLOGY – IDENTIFICATION AND MITIGATION OF GEOLOGIC HAZARDS**

As mentioned previously, detailed mapping has been performed on this site to produce an Engineering Geology Map (Figure 6). This map shows the location of various geologic conditions of which the developers should be cognizant during the planning, design and construction stages of the project. These hazards and the recommended mitigation techniques are as follows:

### Expansive/Collapsible Soils

Expansive and collapsible soils were encountered in the profile hole borings and test pits excavated on-site, expansive clayey sandstone and claystone is commonly encountered within the Dawson Arkose Formation. These occurrences are typically sporadic; therefore, none have been indicated on the maps. These clayey soils, if encountered beneath foundations, can cause differential movement in the structure foundation. These occurrences should be identified and dealt with on an individual basis.

Mitigation: Should expansive soils be encountered beneath the foundation, mitigation will be necessary. Mitigation of expansive soils will require special foundation design. Overexcavation and replacement with non-expansive soils at a minimum of 95% of its maximum Modified Proctor Dry Density, ASTM D-1557 is a suitable mitigation, which is common in the area. Another alternative in areas of highly expansive soils is the use of drilled pier foundation systems. Typical minimum pier depths are on the order of 20 feet or more and require penetration into the bedrock material a minimum of 4 to 6 feet, depending upon building loads. Floor slabs on expansive soils should be expected to experience movement. Overexcavation and replacement has been successful in minimizing slab movements. The use of structural floors should be considered for basement construction on highly expansive clays. Final recommendations should be determined after additional investigation of each building site.

Seasonal Shallow Groundwater Area

In these areas, we would anticipate the potential for periodically high subsurface moisture conditions and frost heave potential. These lie within the drainages and low-lying areas, and can likely be avoided by development or properly mitigated. The potential exists for high groundwater during high moisture periods and should structures encroach on these areas the following precautions should be followed:

Mitigation: Foundations must have a minimum 30-inch depth for frost protection. In areas where high subsurface moisture conditions are anticipated periodically, subsurface perimeter drains are recommended to help prevent the intrusion of water into areas below grade. Typical drain details are presented in Figure 7. Any grading in these areas should be done to direct surface flow around construction to avoid areas of ponded water. All organic material would be completely removed prior to any fill placement. The site does not lie within any mapped floodplain zones according to the FEMA Map No. 08041CO325F, dated March 17, 1997 (Figure 8, Reference 7). Exact locations of floodplain and specific drainage studies are beyond the scope of this report. Finished floor levels must be located a minimum of one foot above floodplain levels.

Areas of Erosion and Gullying

These are areas that are undergoing erosion by water and sheetwash producing gullies and rill erosion.

Mitigation: Due to the nature of the soils on this site, virtually all the soils are subject to erosion by wind and water. Other minor areas of erosion were observed on site other than those mapped, particularly where some rill erosion has occurred. Areas of erosion can occur across the entire site, particularly if the soils are disturbed during construction. Vegetation reduces the potential for erosion. The areas identified where erosion is actually taking place may require check dams, regrading and revegetation using channel lining mats to anchor vegetation. Further recommendations for erosion control are discussed under Section 9.0 "Erosion Control" of this report. Recommendations pertaining to revegetation may require input from a qualified landscape architect and/or the Natural Resource Conservation Service (previously Soil Conservation Service).

### ***6.1 Relevance of Geologic Conditions to Land Use Planning***

As mentioned earlier in this report, we understand that the development will be rural residential. It is our opinion that the existing geologic and engineering geologic conditions will impose some minor constraints on the proposed development and construction. The most significant problems affecting development will be those associated with the drainages on-site that can be avoided or properly mitigated. Other hazards on site may be satisfactorily mitigated through proper engineering design and construction practices.

The upper materials are typically at medium dense states. The granular soils encountered in the upper soil profiles of the profile holes and test pits should provide good support for foundations. Expansive soils were encountered profile holes, and expansive clayey sandstone and claystone is common in the Dawson Formation, and may require mitigation. Foundations anticipated for the site are standard spread footings possibly in conjunction with overexcavation in areas of expansive soils or loose soils. Areas containing arkosic sandstone will have high allowable bearing conditions. Difficult excavation should be anticipated in areas of shallow bedrock. Expansive layers may also be encountered in the soil and bedrock on this site. Areas of expansive soils encountered on site are sporadic; therefore, none have been indicated on the maps. Expansive soils, if encountered, will require special foundation design and/or overexcavation. These soils will not prohibit development.

Areas of seasonal shallow groundwater and areas of ponded water were encountered on site. Due to the size of the lots and the proposed development, these areas can be avoided by construction. Structures should not block drainages. Septic fields should not be located in these areas due to the potential for periodic high groundwater conditions.

In summary, development of the site can be achieved if the items mentioned above are mitigated. These items can be mitigated through proper design and construction or through avoidance. Investigation on each lot is recommended prior to construction.

## 7.0 ON-SITE WASTEWATER TREATMENT

The site was evaluated for individual on-site wastewater treatment systems in accordance with El Paso Land Development Code. Three (3) percolation tests and three (3) tactile test pits were performed on the property. Percolation tests and tactile test pits were located in anticipated locations of proposed systems. The approximate locations of the percolation tests and tactile test pits are indicated on Figure 3, the Geology Map, Figure 6, and on the Septic Suitability Map, Figure 9. Table 2 shows the results of the percolation tests and the limiting soil layers encountered in the tactile test pits. The specific percolation test results are presented in Appendix E of this report.

The Natural Resource Conservation Service (Reference 2), previously the Soil Conservation Service (Reference 3) has been mapped with one soil descriptions. The Soil Survey Map (Reference 2) is presented in Figure 4, and the Soil Survey Descriptions are presented in Appendix D. The soils are described as having moderate to moderately rapid percolation rates.

The percolation rates ranged from 49 to 80 minutes per inch. Two of the percolation rates (Profile Hole Nos. 2 and 3) are suitable for conventional on-site wastewater treatment systems. The percolation rates for Profile Hole No. 1 are slower than 60 minutes per inch which will require designed systems. Limiting soil layers encountered in the test pits ranged from USDA Soil Type 2A to 3A. Soil Types 1 through 3 are suitable for conventional systems, and Soil Types 3A through 5 require designed systems. Shallow bedrock was also encountered in the profile holes and test pits, and will also required a designed system. Additional drilling and/or test pits may identify areas that are suitable for conventional systems.

Soils encountered in the test pits consisted of sandy loam, sandy clay loam, and gravelly sand, with underlying silty sandstone. The limiting layers encountered in the test pits are sandy loam and the silty sandstone, which corresponds to an LTAR values of 0.50 and 0.30 gallons per day per square foot. The bedrock was encountered at 4 feet in the Test Pit No. 3. The conditions encountered in Test Pit No. 3 would require a designed system. Soils encountered in Test Pit Nos. 2 and 3 are suitable for conventional systems.

Standard penetration testing, ASTM D-1586, was performed in each profile hole to evaluate the density of the soil and the presence of bedrock. Bedrock was encountered in Profile Hole No. 1 at 11 feet and Test Pit No. 1 at 4 feet. Designed systems are required in areas of shallow bedrock.

Absorption fields must be maintained a minimum of 4 feet above groundwater or bedrock. Groundwater was encountered in Profile Hole No. 1 at 15 feet, groundwater was not encountered in the other profile holes which were drilled to depths of 15 feet. Shallow bedrock was encountered in the profile holes and test pits at depths ranging from 4 to 11 feet. Should groundwater or bedrock be encountered within 6 feet of the surface, designed systems will be required.

The percolation rates in the locations of Profile Hole Nos. 2 and 3 are suitable for conventional systems, percolation rates for Profile Hole No. 1 will require a designed system. Profile Hole Nos. 2 and 3 had rates of faster than 60 minutes per inch, and Profile Hole No. 1 had rates slower than 60 minutes per inch. El Paso County guidelines require designed systems for percolation rates exceed 60 minutes per inch. Additional drilling may identify areas where conventional systems can be used. Bedrock was encountered in Test Pit No. 1 at a depth that would affect conventional systems. Where bedrock is encountered above 6 feet, designed systems may be required. In areas where suitable percolation rates cannot be found, shallow groundwater exists or shallow bedrock exists, designed systems will be required.

In summary, it is our opinion the site is suitable for individual on-site wastewater treatment systems (OWTS) and that contamination of surface and subsurface water resources should not occur provided the OWTS sites are evaluated and installed according to El Paso County and State Guidelines and properly maintained. Based on the testing performed as part of this investigation designed systems will be required. A Septic Suitability Map is presented in Figure 9. Individual site evaluation is required on each lot prior to construction. Absorption fields must be located a minimum of 100 feet from any well, including those on adjacent properties. Absorption fields must also be located a minimum of 50 feet from any drainages, floodplains or ponded areas and 25 feet from dry gulches.

## 8.0 ECONOMIC MINERAL RESOURCES

Some of the sandy materials on-site could be considered a low grade sand resource. According to the *El Paso County Aggregate Resource Evaluation Map* (Reference 8), the area is not mapped with any aggregate deposits. According to the *Atlas of Sand, Gravel and Quarry Aggregate Resources, Colorado Front Range Counties* distributed by the Colorado Geological Survey (Reference 9), areas of the site are not mapped with any resources. According to the *Evaluation of Mineral and Mineral Fuel Potential* (Reference 10), the area of the site has been mapped as “poor” for industrial minerals. However, considering the silty nature of much of these materials and abundance of similar materials through the region and the close proximity to developed land, they would be considered to have little significance as an economic resource.

According to *the Evaluation of Mineral and Mineral Fuel Potential of El Paso County State Mineral Lands* (Reference 10), the site is mapped within the Denver Basin Coal Region. However, the area of the site has been mapped as “Poor” for coal resources. No active or inactive mines have been mapped in the area of the site. No metallic mineral resources have been mapped on the site (Reference 10).

The site has been mapped as “Fair” for oil and gas resources (Reference 10). No oil or gas fields have been discovered in the area of the site. The sedimentary rocks in the area may lack the geologic structure for trapping oil or gas; therefore, it may not be considered a significant resource. Hydraulic fracturing is a new method that is being used to extract oil and gas from rocks. It utilizes pressurized fluid to extract oil and gas from rocks that would not normally be productive. The area of the site has not been explored to determine if the rocks underlying the site would be commercially viable utilizing hydraulic fracturing. The practice of hydraulic fracturing has come under review due to concerns about environmental impacts, health and safety.

## 9.0 EROSION CONTROL

The soil types observed on the site are mildly to highly susceptible to wind erosion, and moderately to highly susceptible to water erosion. A minor wind erosion and dust problem may be created for a short time during and immediately after construction. Should the problem be considered severe enough during this time, watering of the cut areas or the use of chemical palliative may be required to control dust. However, once construction has been completed and vegetation re-established, the potential for wind erosion should be considerably reduced.

With regard to water erosion, loosely compacted soils will be the most susceptible to water erosion, residually weathered soils and weathered bedrock materials become increasingly less susceptible to water erosion. For the typical soils observed on site, allowable velocities or unvegetated and unlined earth channels would be on the order of 3 to 4 feet/second, depending upon the sediment load carried by the water. Permissible velocities may be increased through the use of vegetation to something on the order of 4 to 7 feet/second, depending upon the type of vegetation established. Should the anticipated velocities exceed these values, some form of channel lining material may be required to reduce erosion potential. These might consist of some of the synthetic channel lining materials on the market or conventional riprap. In cases where ditch-lining materials are still insufficient to control erosion, small check dams or sediment traps may be required. The check dams will serve to reduce flow velocities, as well as provide small traps for containing sediment. The determination of the amount, location and placement of ditch linings, check dams and of the special erosion control features should be performed by or in conjunction with the drainage engineer who is more familiar with the flow quantities and velocities.

Cut and fill slope areas will be subjected primarily to sheetwash and rill erosion. Unchecked rill erosion can eventually lead to concentrated flows of water and gully erosion. The best means to combat this type of erosion is, where possible, the adequate re-vegetation of cut and fill slopes. Cut and fill slopes having gradients more than three (3) horizontal to one (1) vertical become increasingly more difficult to revegetate successfully. Therefore, recommendations pertaining to the vegetation of the cut and fill slopes may require input from a qualified landscape architect and/or the Soil Conservation Service.

## **10.0 CLOSURE**

It is our opinion that the existing geologic engineering and geologic conditions will impose some minor constraints on development and construction of the site. The majority of these conditions can be avoided by construction. Others can be mitigated through proper engineering design and construction practices. The proposed development and use is consistent with anticipated geologic and engineering geologic conditions.

It should be pointed out that because of the nature of data obtained by random sampling of such variable and non-homogeneous materials as soil and rock, it is important that we be informed of any differences observed between surface and subsurface conditions encountered in construction and those assumed in the body of this report. Individual investigations for building sites and septic systems will be required prior to construction. Construction and design personnel should be made familiar with the contents of this report. Reporting such discrepancies to Entech Engineering, Inc. soon after they are discovered would be greatly appreciated and could possibly help avoid construction and development problems.

This report has been prepared for Jerome Hannigan and Associates, Inc. for application to the proposed project in accordance with generally accepted geologic soil and engineering practices. No other warranty expressed or implied is made.

We trust that this report has provided you with all the information that you required. Should you require additional information, please do not hesitate to contact Entech Engineering, Inc.



## BIBLIOGRAPHY

1. Bryant, Bruce; McGrew, Laura W, and Wabus, Reinhard A. 1981. *Geologic Structure Map of the Denver 1° x 2° Quadrangle, North-Central Colorado*. Sheet 2. U.S. Geologic Survey. Map I-1163.
2. Natural Resource Conservation Service, September 23, 2016. *Web Soil Survey*. United States Department Agriculture, <http://websoilsurvey.sc.egov.usda.gov/App/HomePage.htm>.
3. United States Department of Agriculture Soil Conservation Service. June 1981. *Soil Survey of El Paso County Area, Colorado*.
4. Thorson, Jon P. 2003. *Geologic Map of the Black Forest Quadrangle, El Paso County, Colorado*. Colorado Geological Survey. Open-File Report 03-06.
5. Trimble, Donald E. and Machette, Michael N. 1979. *Geologic Map of the Colorado Springs-Castle Rock Area, Front Range Urban Corridor, Colorado*. USGS, Map I-857-F.
6. Bryant, Bruce; McGrew, Laura W. and Wobus, Reinhard A. 1981. *Geologic Map of the Denver 1° x 2° Quadrangle, North-Central Colorado*. U.S. Geologic Survey. Map 1-1163.
7. Federal Emergency Management Agency. March 17, 1997. *Flood Insurance Rate Maps for the City of Colorado Springs, Colorado*. Map Number 08041CO325F
8. El Paso County Planning Development. December 1995. *El Paso County Aggregate Resource Evaluation Maps*.
9. Schwochow, S.D.; Shroba, R.R. and Wicklein, P.C. 1974. *Atlas of Sand, Gravel, and Quarry Aggregate Resources, Colorado Front Range Counties*. Colorado Geological Survey. Special Publication 5-B.
10. Keller, John W.; TerBest, Harry and Garrison, Rachel E. 2003. *Evaluation of Mineral and Mineral Fuel Potential of El Paso County State Mineral Lands Administered by the Colorado State Land Board*. Colorado Geological Survey. Open-File Report 03-07.

## TABLES

**TABLE 1**  
**SUMMARY OF LABORATORY TEST RESULTS**

CLIENT JEROME HANNIGAN & ASSOC.  
PROJECT SILVER NELL & SETTLERS VIEW  
JOB NO. 162442

SOIL TYPE	TEST BORING NO.	DEPTH (FT)	WATER (%)	DRY DENSITY (PCF)	PASSING NO. 200 SIEVE (%)	LIQUID LIMIT (%)	PLASTIC INDEX (%)	USDA SOIL TYPE	FHA SWELL (PSF)	SWELL/CONSOL (%)	UNIFIED CLASSIFICATION	SOIL DESCRIPTION
1	PH-3	2-3			13.7						SM	SAND, SILTY
1	PH-2	5			19.5						SM	SAND, SILTY
1	TP-1	7-8			5.5			1			SM-SW	SAND, SLIGHTLY SILTY
1	TP-2	2-3			21.2			2A			SC	SAND, CLAYEY
1	TP-3	2-3			49.4			3A			SC	SAND, VERY CLAYEY
2	PH-1	10	15.2	122.4	60.1					0.0	CL	CLAY, VERY SANDY
3	PH-1	15			15.4						SM	SANDSTONE, SILTY

**Table 2: Summary of Percolation Test and Tactile Test Pit Results**

<b>Percolation Test No.</b>	<b>Percolation Rate (min/in)</b>	<b>Depth to Bedrock (ft.)</b>	<b>Depth to Groundwater (ft.)</b>
1	80*	11	15
2	58	N/A	N/A
3	49	N/A	N/A

<b>Test Pit No.</b>	<b>USDA Soil Type</b>	<b>LTAR Value</b>	<b>Depth to Bedrock (ft.)</b>	<b>Depth to Groundwater (ft.)</b>
1	2A	0.50	N/A	N/A
2	2A	0.50	N/A	N/A
3	3A*	0.30*	4	N/A

\*- These sites require engineered design OWTS

## FIGURES

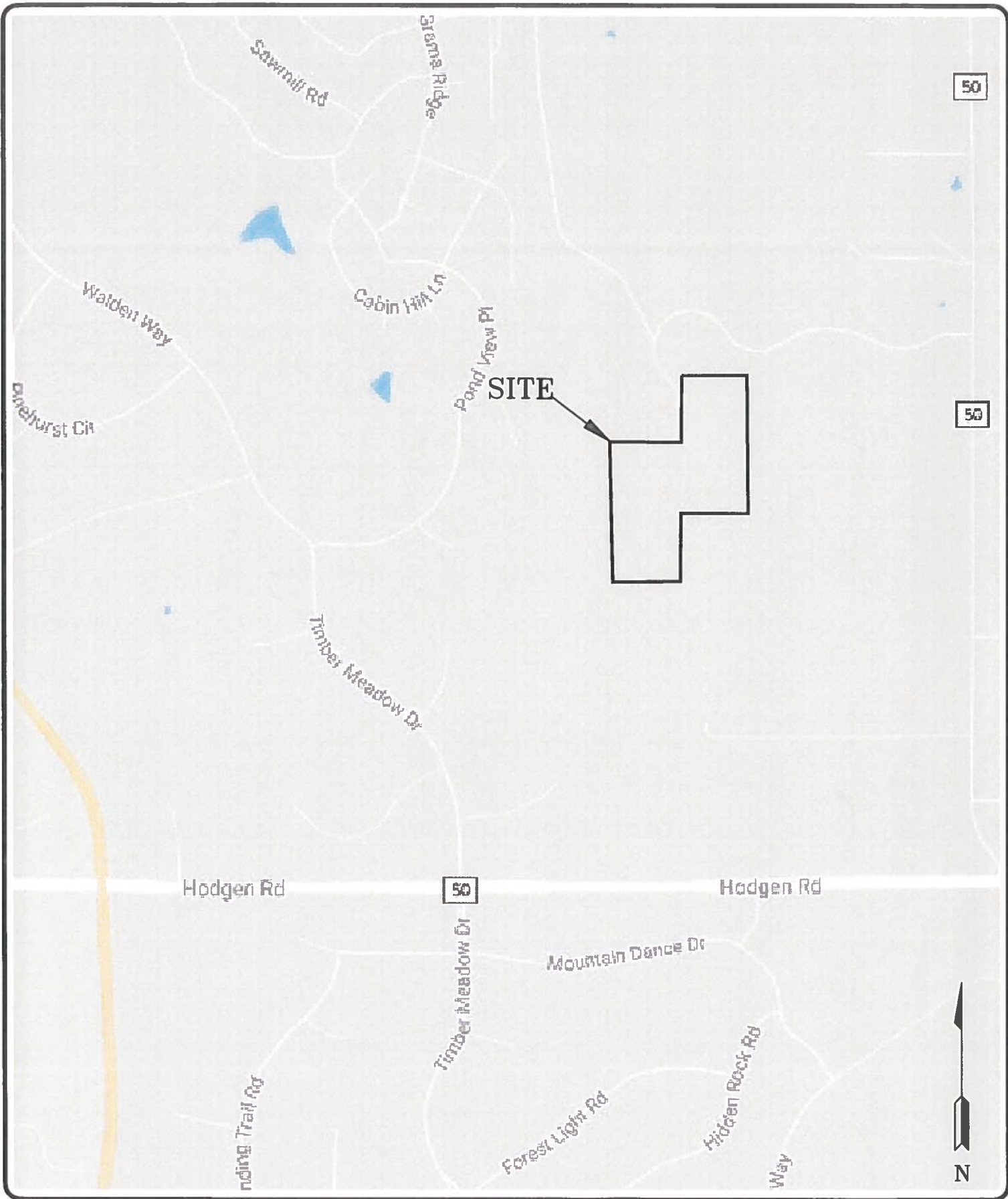

**ENTECH**  
**ENGINEERING, INC.**  
 565 ELKTON DRIVE  
 COLORADO SPRINGS, CO. 80907 (719) 531-5599

VICINITY MAP  
 SETTLERS VIEW SUBDIVISION  
 EL PASO COUNTY, CO.  
 FOR: JEROME HANNIGAN & ASSOCIATES, INC.

DRAWN: LLL	DATE: 1/31/17	CHECKED:	DATE:
---------------	------------------	----------	-------

JOB NO.:  
 162442  
 FIG NO.:  
 1

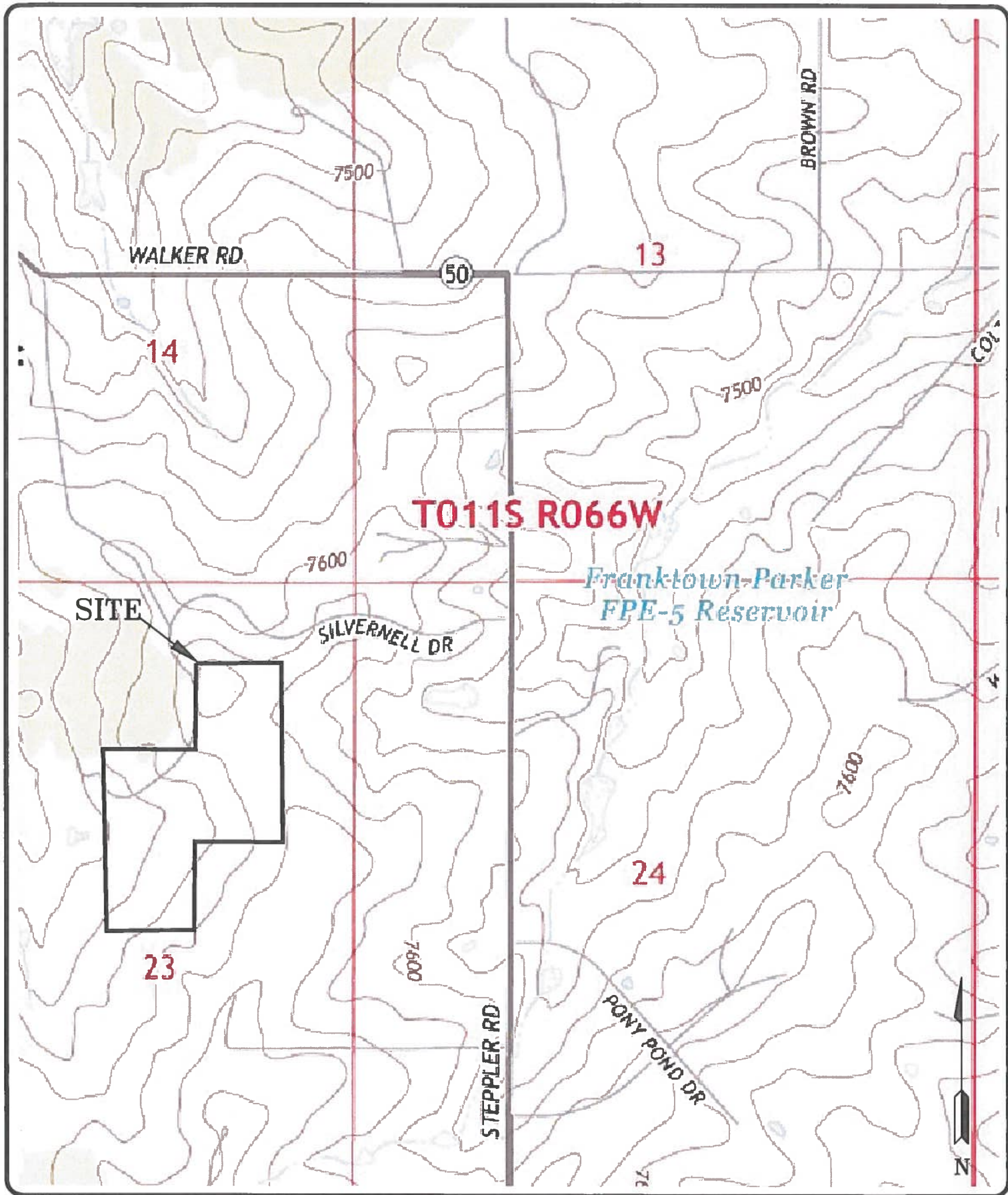

**ENTECH**  
**ENGINEERING, INC.**  
 505 ELKTON DRIVE  
 COLORADO SPRINGS, CO. 80907 (719) 531-5599

USGS MAP  
 SETTLERS VIEW SUBDIVISION  
 EL PASO COUNTY, CO.  
 FOR: JEROME HANNIGAN & ASSOCIATES, INC.

DRAWN:  
 LLL

DATE:  
 1/31/17

CHECKED:

DATE:

JOB NO.:  
 162442

FIG NO.:  
 2



DATE 1/31/17	3
SCALE	
AS SHOWN	
JOB NO. 102442	

**SITE PLAN/TEST BORING LOCATION MAP**  
**SETTLERS VIEW SUBDIVISION**  
**EL PASO COUNTY, CO.**  
**FOR: JEROME HANNIGAN & ASSOCIATES, INC.**

**ENTECH ENGINEERING, INC.**  
 505 ELKTON DRIVE  
 COLORADO SPRINGS, CO. 80907 (719) 531-5599

REVISION	BY





**ENTECH**  
**ENGINEERING, INC.**  
505 ELKTON DRIVE  
COLORADO SPRINGS, CO. 80907 (719) 531-5599

SCS MAP  
SETTLERS VIEW SUBDIVISION  
EL PASO COUNTY, CO.  
FOR: JEROME HANNIGAN & ASSOCIATES, INC.

DRAWN:  
LLL

DATE:  
1/31/17

CHECKED:

DATE:

JOB NO.:  
162442

FIG NO.:  
4

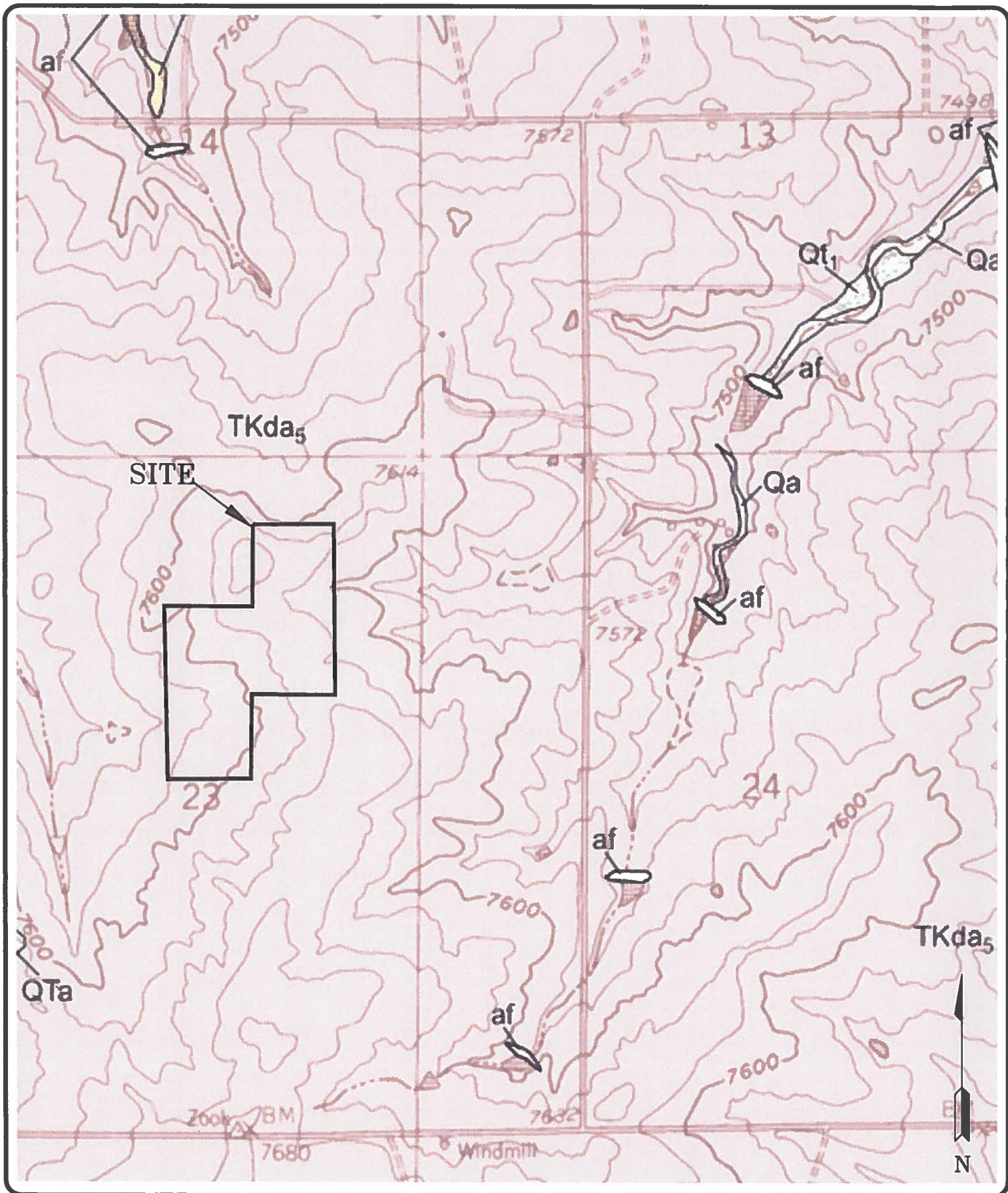

**ENTECH**  
**ENGINEERING, INC.**  
 505 ELKTON DRIVE  
 COLORADO SPRINGS, CO. 80907 (719) 531-5599

BLACK FOREST QUADRANGLE GEOLOGY MAP  
 SETTLERS VIEW SUBDIVISION  
 EL PASO COUNTY, CO.  
 FOR: JEROME HANNIGAN & ASSOCIATES, INC.

DRAWN:  
 LLL

DATE:  
 1/31/17

CHECKED:

DATE:

JOB NO.:  
 162442

FIG NO.:  
 5

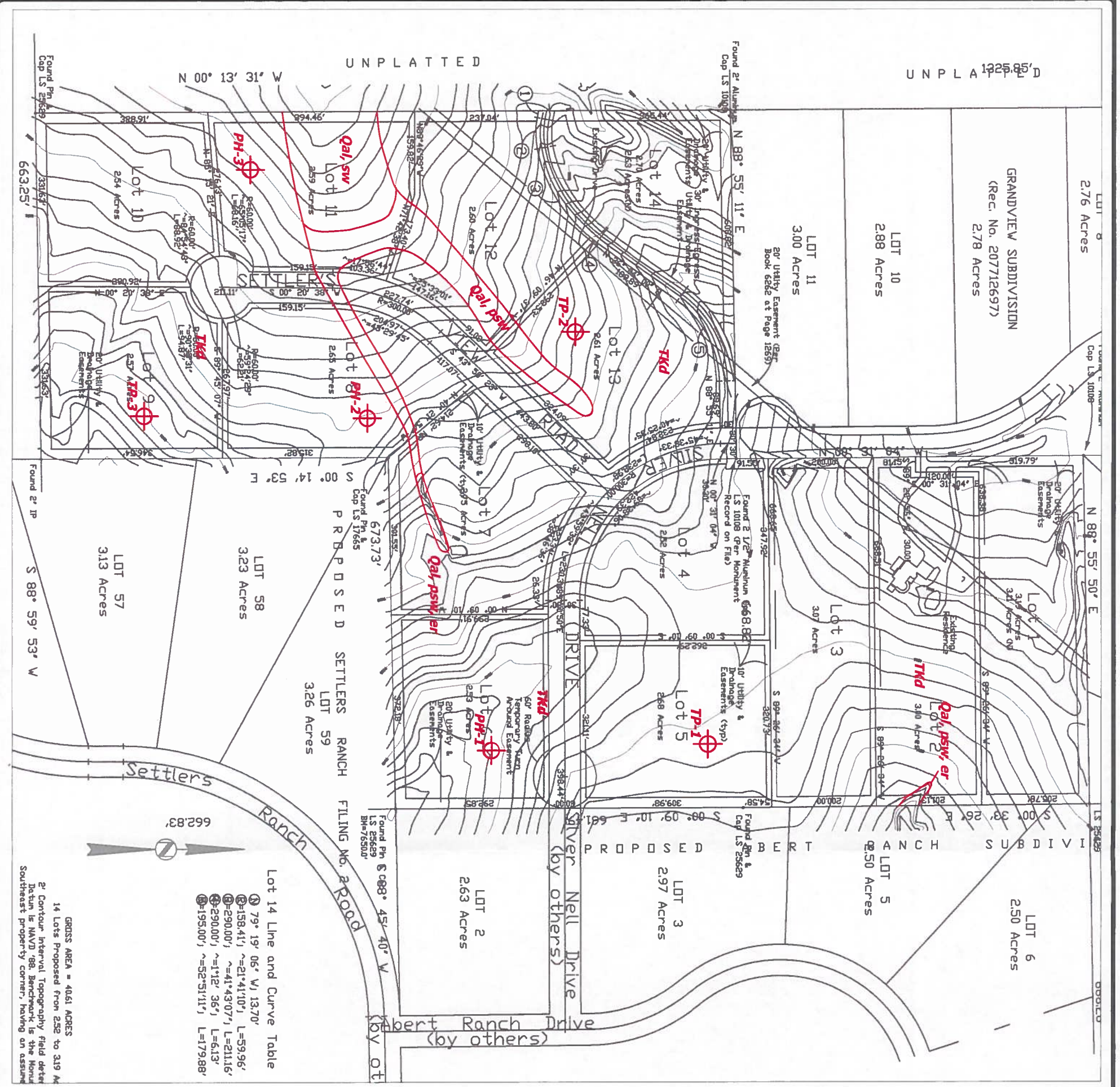

- Legend:**
- Qal - Recent Alluvium of Holocene Age:  
water deposited stream terrace deposits
  - Tkd - Dawson Formation of Tertiary to Cretaceous Age:  
arkosic sandstone with siltstone and claystone lenses
  - psw - potentially seasonal shallow groundwater
  - sw - seasonal shallow groundwater
  - er - areas of erosion
  - TP - APPROXIMATE TEST PIT LOCATION AND NUMBER
  - PH - APPROXIMATE PROFILE HOLE LOCATION AND NUMBER

Lot 14 Line and Curve Table

N	79° 19' 06" W	13.70'
②	158.41'	~21° 41' 10"
③	290.00'	~41° 43' 07"
④	290.00'	~1° 12' 36"
⑤	195.00'	~92° 51' 11"

GRASS AREA = 40.61 ACRES  
 14 Lots Proposed from 2.52 to 3.19 A  
 2' Contour Interval Topography field dete  
 Datum is NAVD '88. Benchmark is the Horiz  
 Southeast property corner, having an assum

ENGINEERING GEOLOGY MAP  
 SETTLERS VIEW SUBDIVISION  
 EL PASO COUNTY, CO.  
 FOR: JEROME HANNIGAN &  
 ASSOCIATES, INC.

**ENTECH**  
 ENGINEERING, INC.  
 505 ELKTON DRIVE  
 COLORADO SPRINGS, CO. 80907 (719) 531-5599

REVISION BY	DATE	DESCRIPTION

DRAWN	
CHECKED	
DATE	2/2/17
SCALE	AS SHOWN
DWG NO.	102442
REVISION	6

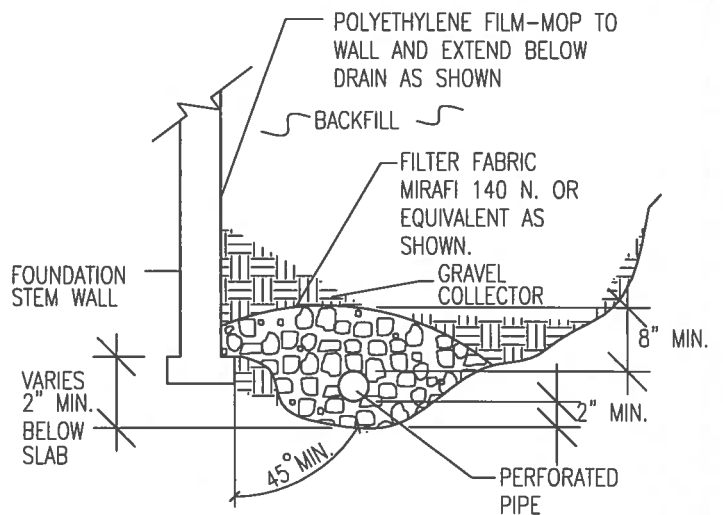
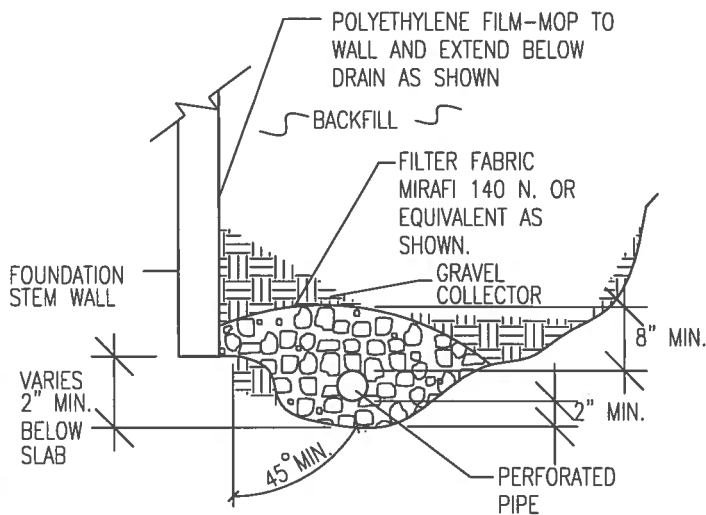

NOTES:

-GRAVEL SIZE IS RELATED TO DIAMETER OF PIPE PERFORATIONS-85% GRAVEL GREATER THAN 2x PERFORATION DIAMETER.

-PIPE DIAMETER DEPENDS UPON EXPECTED SEEPAGE. 4-INCH DIAMETER IS MOST OFTEN USED.

-ALL PIPE SHALL BE PERFORATED PLASTIC. THE DISCHARGE PORTION OF THE PIPE SHOULD BE NON-PERFORATED PIPE.

-FLEXIBLE PIPE MAY BE USED UP TO 8 FEET IN DEPTH, IF SUCH PIPE IS DESIGNED TO WITHSTAND THE PRESSURES. RIGID PLASTIC PIPE WOULD OTHERWISE BE REQUIRED.

-MINIMUM GRADE FOR DRAIN PIPE TO BE 1% OR 3 INCHES OF FALL IN 25 FEET.

-DRAIN TO BE PROVIDED WITH A FREE GRAVITY OUTFALL, IF POSSIBLE. A SUMP AND PUMP MAY BE USED IF GRAVITY OUT FALL IS NOT AVAILABLE.



**ENTECH**  
ENGINEERING, INC.  
565 ELKTON DRIVE  
COLORADO SPRINGS, CO. 80907 (719) 531-5599

*PERIMETER DRAIN DETAIL*

DRAWN:

DATE:

DESIGNED:

DS

CHECKED:

LLL

JOB NO.:

162442

FIG NO.:

7

**LEGEND**

**SPECIAL FLOOD HAZARD AREAS SUBJECT TO INUNDATION BY THE 1% ANNUAL CHANCE FLOOD**

The 1% annual chance flood (100-year flood) also known as the base flood is the flood that has a 1% chance of being equaled or exceeded in any given year. The Special Flood Hazard Area is the area subject to flooding by the 1% annual chance flood. Areas of Special Flood Hazard include Zones A, AE, AH, AO, AR, A99, V, and VE. The Base Flood Elevation is the water-surface elevation of the 1% annual chance flood.

**ZONE A** No Base Flood Elevations determined.

**ZONE AE** Base Flood Elevations determined.

**ZONE AH** Flood depths of 1 to 3 feet (usually areas of ponding); Base Flood Elevation determined.

**ZONE AO** Flood depths of 1 to 3 feet (usually sheet flow on sloping terrain); average depths determined. For areas of alluvial fan flooding, velocities also determined.

**ZONE AR** Special Flood Hazard Area formerly protected from the 1% annual chance flood by a Federal Flood Control System that has been identified. Zone AR indicates that the former flood control system is being retained to provide protection from the 1% annual chance or greater flood.

**ZONE AP9** Area to be protected from 1% annual chance flood by a Federal flood protection system under construction; no Base Flood Elevations determined.

**ZONE V** Coastal flood zone with velocity hazard (wave action); no Base Flood Elevations determined.

**ZONE VE** Coastal flood zone with velocity hazard (wave action); Base Flood Elevations determined.

**FLOODWAY AREAS IN ZONE AE**

The floodway is the channel of a stream plus any adjacent floodplain areas that must be kept free of encroachment so that the 1% annual chance flood can be carried without substantial increases in flood heights.

**OTHER FLOOD AREAS**

Areas of 0.2% annual chance flood; areas of 1% annual chance flood with average depths of less than 1 foot or with drainage areas less than 1 square mile; and areas protected by levees from 1% annual chance flood.

**OTHER AREAS**

Areas determined to be outside the 0.2% annual chance floodplain. Areas in which flood hazards are undetermined, but possible.

**COASTAL BARRIER RESOURCES SYSTEM (CBRS) AREAS**

CBRS areas and OPAs are normally located within or adjacent to Special Flood Hazard Areas.

**OTHERWISE PROTECTED AREAS (OPAs)**

1% annual chance floodplain boundary  
0.2% annual chance floodplain boundary  
Floodway boundary  
Zone D boundary  
CBRS and OPA boundary

Boundary dividing Special Flood Hazard Areas of different Base Flood Elevations, flood depths or flood velocities.  
Base Flood Elevation line and value: elevation in feet\* (ILL. 807)

Base Flood Elevation value where written within area; elevation in feet\*  
Referenced to the National Geodetic Vertical Datum of 1989

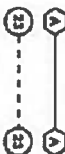

Cross section line  
Transect line  
Geographic coordinates referenced to the North American Datum of 1983 (NAD 83), Western Hemisphere

427600m  
800000 FT  
5000-foot grid tick values: Hawaii State Plane coordinate system, zone 3 (NAD 83) (SPSZONE 5103), Transverse Mercator projection  
Bench mark (see explanation in Notes to Users section of the FRM panel)  
Coastal mile marker

MAP REPOSITORY  
Refer to listing of Map Repositories on Map Index  
EFFECTIVE DATE OF COUNTYWIDE FLOOD INSURANCE RATE MAP  
November 20, 2000

EFFECTIVE DATES (OR REVISIONS) TO THIS PANEL  
September 30, 2004 - to change Special Flood Hazard Areas, to update map format, to reflect revised shoreline and to incorporate previously issued Letters of Map Revision.

For community map revision history, prior to countywide mapping, refer to the Community Map History table located in the Flood Insurance Study report for this jurisdiction.  
To determine if flood insurance is available in this community, contact your insurance agent or call the National Flood Insurance Program at 1-800-438-6520.

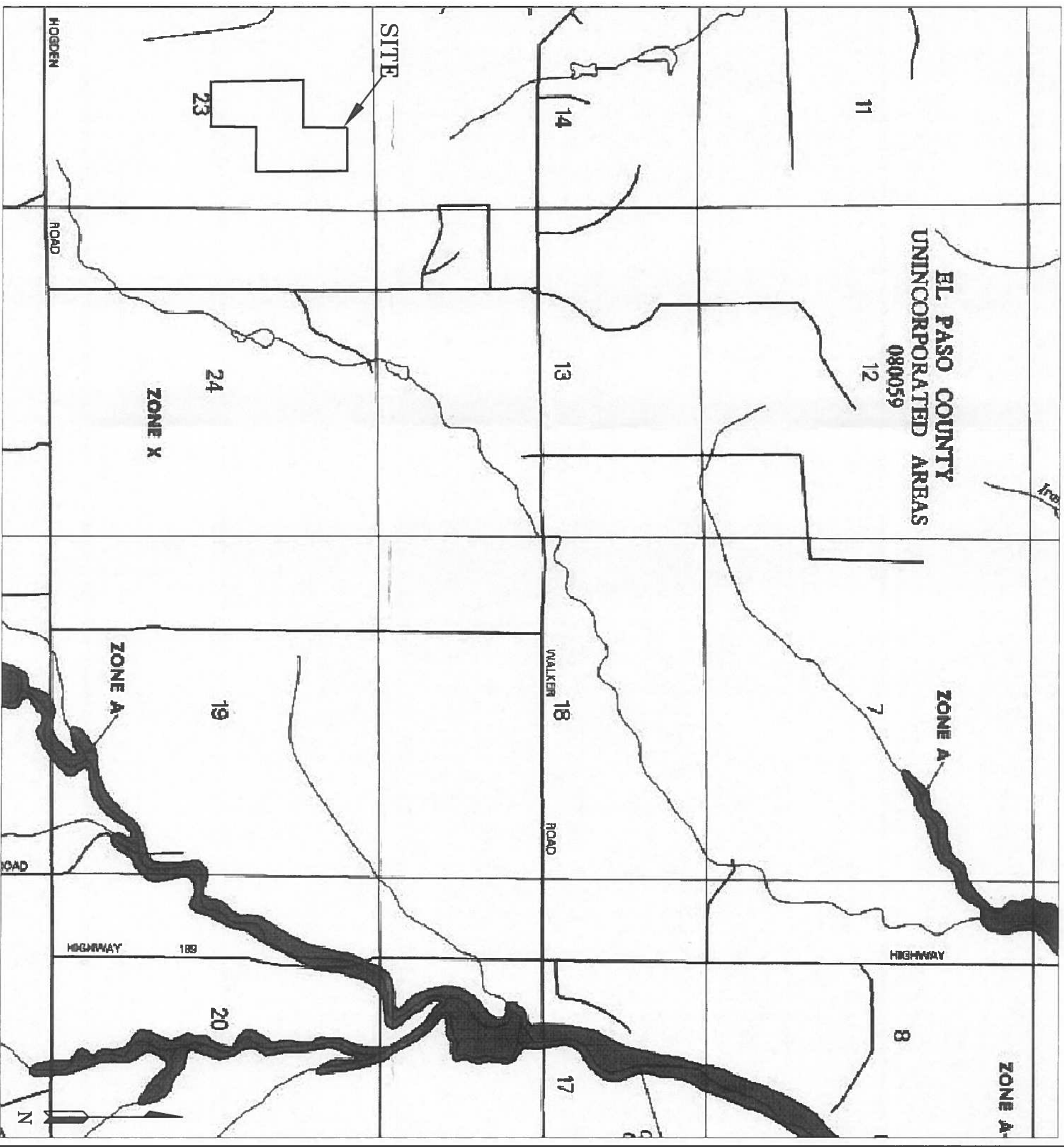

**EL PASO COUNTY  
UNINCORPORATED AREAS  
080059**

**ZONE A**

**ZONE A**

**ZONE X**

**ZONE A**

HOGDEN ROAD

ROAD

HIGHWAY 181

WALKER ROAD

HIGHWAY 181

N

**FLOODPLAIN MAP  
SETTLERS VIEW SUBDIVISION  
EL PASO COUNTY, CO.  
FOR: JEROME HANNIGAN &  
ASSOCIATES, INC.**



**ENTECH  
ENGINEERING, INC.**  
505 ELKTON DRIVE  
COLORADO SPRINGS, CO. 80907 (719) 531-5599

REVISION BY

DRAWN  
TAL  
CHECKED

DATE  
1/31/17

SCALE  
AS SHOWN

JOB NO.  
102442

DATE  
8



## **APPENDIX A: Site Photographs**

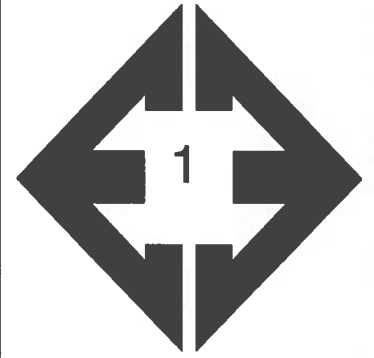

**Looking north from the northeastern portion of the site.**

December 15, 2016

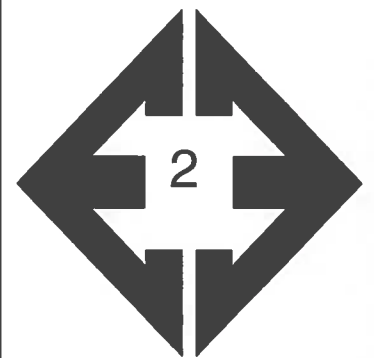

**Looking east from the northeastern portion of the site.**

December 15, 2016



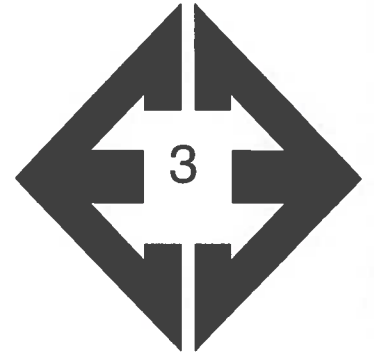

**Looking southwest  
from the south central  
portion of the site.**

December 15, 2016

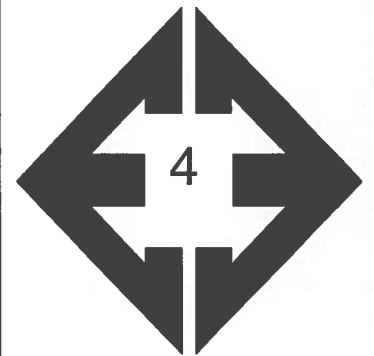

**Looking west from the  
central portion of the  
site.**

December 15, 2016

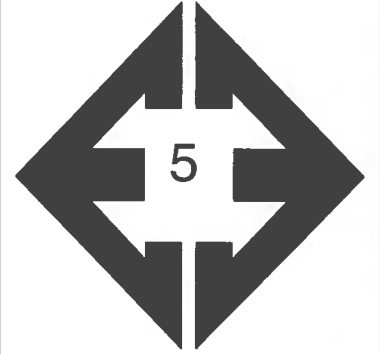

**Looking north from the southeastern corner of the site.**

December 15, 2016

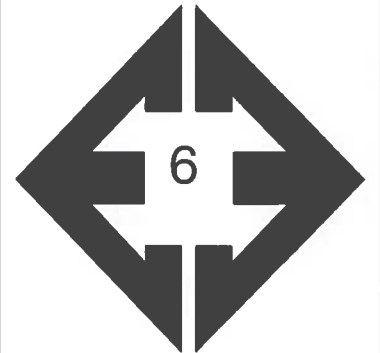

**Looking north from the western portion of the site.**

December 15, 2016

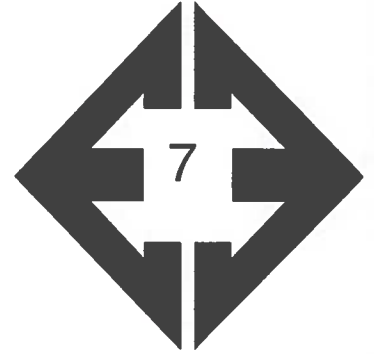

**Looking east at erosion feature southeastern portion of the site.**

December 15, 2016

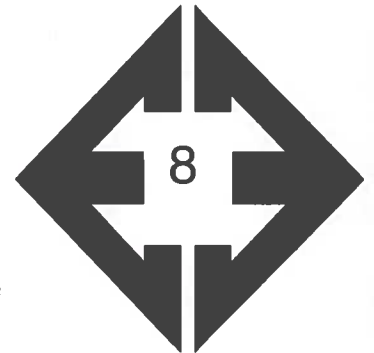

**Looking west from the southeastern portion of the site.**

December 15, 2016

**APPENDIX B: Test Boring Logs from the Profile Holes  
and Test Pit Logs**

PROFILE HOLE NO. 1  
 DATE DRILLED 1/11/2017  
 Job # 162442

PROFILE HOLE NO. 2  
 DATE DRILLED 1/11/2017  
 CLIENT JEROME HANNIGAN & ASSOC.  
 LOCATION SILVER NELL & SETTLERS VIEW

REMARKS	Depth (ft)	Symbol	Samples	Blows per foot	Watercontent %	Soil Type	REMARKS	Depth (ft)	Symbol	Samples	Blows per foot	Watercontent %	Soil Type
WATER @ 15', 1/12/17							DRY TO 15', 1/12/17						
SAND, SILTY TO CLAYEY, FINE TO COARSE GRAINED, GRAY BROWN, MEDIUM DENSE, MOIST	5	[Symbol]		25	6.7		SAND, SILTY TO CLAYEY, FINE TO COARSE GRAINED, GRAY BROWN, MEDIUM DENSE TO LOOSE, MOIST	5	[Symbol]		11	6.2	
	5	[Symbol]		16	7.6			5	[Symbol]		9	9.4	
CLAY, VERY SANDY, BROWN, FIRM, MOIST	10	[Symbol]		10	15.5			10	[Symbol]		18	9.8	
SANDSTONE, SILTY, FINE TO COARSE GRAINED, TAN, VERY DENSE, MOIST	15	[Symbol]		50	5.9			15	[Symbol]		11	9.0	
				11"									
	20							20					



**ENTECH**  
 ENGINEERING, INC.

505 ELKTON DRIVE  
 COLORADO SPRINGS, COLORADO 80907

**PROFILE HOLE LOG**

DRAWN:

DATE:

CHECKED:

DATE:

*[Signature]* 1/17/17

JOB NO.:

162442

FIG NO.:

B-1

PROFILE HOLE NO. 3  
 DATE DRILLED 1/11/2017  
 Job # 162442

PROFILE HOLE NO.  
 DATE DRILLED  
 CLIENT JEROME HANNIGAN & ASSOC.  
 LOCATION SILVER NELL & SETTLERS VIEW

REMARKS

REMARKS

DRY TO 15', 1/12/17  
 SAND, SILTY TO CLAYEY, FINE  
 TO COARSE GRAINED, GRAY  
 BROWN, MEDIUM DENSE, MOIST

Depth (ft)	Symbol	Samples	Blows per foot	Watercontent %	Soil Type
5			16	4.0	
5			10	6.8	
10			12	14.5	
15			28	8.6	
20					

Depth (ft)	Symbol	Samples	Blows per foot	Watercontent %	Soil Type
5					
10					
15					
20					



**ENTECH**  
 ENGINEERING, INC.

505 ELKTON DRIVE  
 COLORADO SPRINGS, COLORADO 80907

**PROFILE HOLE LOG**

DRAWN:

DATE:

CHECKED:

DATE:

*A* 1/17/17

JOB NO.:

162442

FIG NO.:

B-2

TEST PIT NO. 1  
 DATE EXCAVATED 12/15/2016  
 Job # 162442

TEST PIT NO. 2  
 DATE EXCAVATED 12/15/2016  
 CLIENT JEROME HANIGAN & ASSOCIATES  
 LOCATION SETTLERS VIEW SUBDIVISION

REMARKS	Depth (ft)	Symbol	Samples	Soil Structure Shape	Soil Structure Grade	USDA Soil Type	REMARKS	Depth (ft)	Symbol	Samples	Soil Structure Shape	Soil Structure Grade	USDA Soil Type
topsoil, sandy loam, dark brown	1			gr	w	2A	topsoil, sandy loam, dark brown	1			gr	w	2A
sandy loam, fine to coarse grained, reddish brown	2			gr	w	2A	sandy loam, fine to coarse grained, reddish brown	2			gr	w	2A
	3							3					
	4							4					
	5							5					
	6							6					
gravelly sand, medium to coarse grained, tan	7			sg		1	gravelly sand, medium to coarse grained, tan	7			sg		1
	8							8					
	9							9					
	10							10					

Soil Structure Shape

- granular - gr
- platy - pl
- blocky - bl
- prismatic - pr
- single grain - sg
- massive - ma

Soil Structure Grade

- weak - w
- moderate - m
- strong - s
- loose - l



**ENTECH**  
**ENGINEERING, INC.**

505 ELKTON DRIVE  
 COLORADO SPRINGS, COLORADO 80907

**TEST PIT LOG**

DRAWN:

DATE:

CHECKED:  
 LLL

DATE:  
 1/17/17

JOB NO.:

162442

FIG NO.:

B-3

TEST PIT NO. 3  
 DATE EXCAVATED 12/15/2016  
 Job # 162442

CLIENT LOCATION JEROME HANIGAN & ASSOCIATES  
 SETTLERS VIEW SUBDIVISION

REMARKS	Depth (ft)	Symbol	Samples	Soil Structure Shape	Soil Structure Grade	USDA Soil Type	REMARKS	Depth (ft)	Symbol	Samples	Soil Structure Shape	Soil Structure Grade	USDA Soil Type
topsoil, sandy loam, dark brown	1	⊛		gr	w	2A		1					
gravelly sandy clay loam, fine to coarse grained, reddish tan	2	⊛		gr	w	3A		2					
	3	⊛						3					
	4	⊛						4					
silty sandstone, fine to coarse grained, tan	5	⊛		ma		3A		5					
	6	⊛						6					
	7	⊛						7					
	8	⊛						8					
	9	⊛						9					
	10	⊛						10					

Soil Structure Shape

- granular - gr
- platy - pl
- blocky - bl
- prismatic - pr
- single grain - sg
- massive - ma

Soil Structure Grade

- weak - w
- moderate - m
- strong - s
- loose - l



**ENTECH  
ENGINEERING, INC.**

505 ELKTON DRIVE  
 COLORADO SPRINGS, COLORADO 80907

**TEST PIT LOG**

DRAWN:

DATE:

CHECKED:  
 LLL

DATE:  
 1/17/17

JOB NO.:

162442

FIG NO.:

B-4



## **APPENDIX C: Laboratory Test Results**

<b>UNIFIED CLASSIFICATION</b>	SM	<b>CLIENT</b>	JEROME HANNIGAN & ASSOC.
<b>SOIL TYPE #</b>	1	<b>PROJECT</b>	SILVER NELL & SETTLERS VIEW
<b>TEST BORING #</b>	PH-3	<b>JOB NO.</b>	162442
<b>DEPTH (FT)</b>	2-3	<b>TEST BY</b>	BL

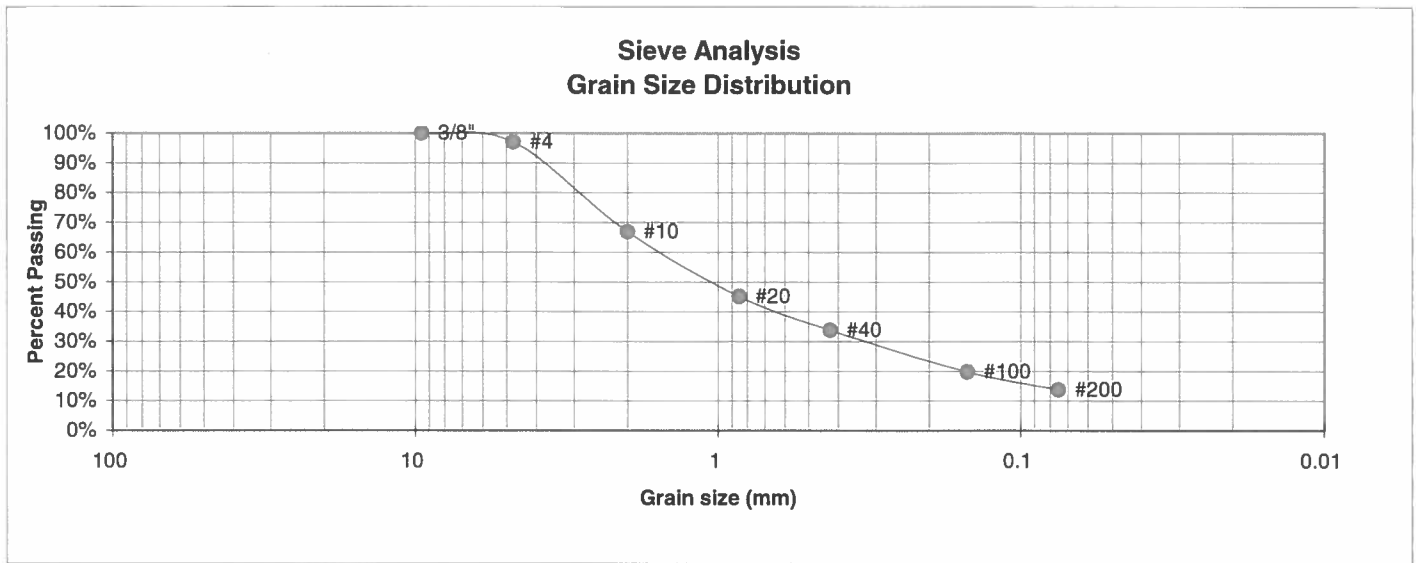

U.S. Sieve #	Percent Finer
3"	
1 1/2"	
3/4"	
1/2"	
3/8"	100.0%
4	97.0%
10	66.9%
20	45.1%
40	33.8%
100	19.7%
200	13.7%

**Atterberg Limits**  
 Plastic Limit  
 Liquid Limit  
 Plastic Index

**Swell**  
 Moisture at start  
 Moisture at finish  
 Moisture increase  
 Initial dry density (pcf)  
 Swell (psf)



**ENTECH  
ENGINEERING, INC.**

505 ELKTON DRIVE  
COLORADO SPRINGS, COLORADO 80907

**LABORATORY TEST  
RESULTS**

DRAWN:	DATE:	CHECKED: <i>[Signature]</i>	DATE: 4/17/17
--------	-------	-----------------------------	---------------

JOB NO.:

162442  
FIG NO.:

C-1

<u>UNIFIED CLASSIFICATION</u>	SM	<u>CLIENT</u>	JEROME HANNIGAN & ASSOC.
<u>SOIL TYPE #</u>	1	<u>PROJECT</u>	SILVER NELL & SETTLERS VIEW
<u>TEST BORING #</u>	PH-2	<u>JOB NO.</u>	162442
<u>DEPTH (FT)</u>	5	<u>TEST BY</u>	BL

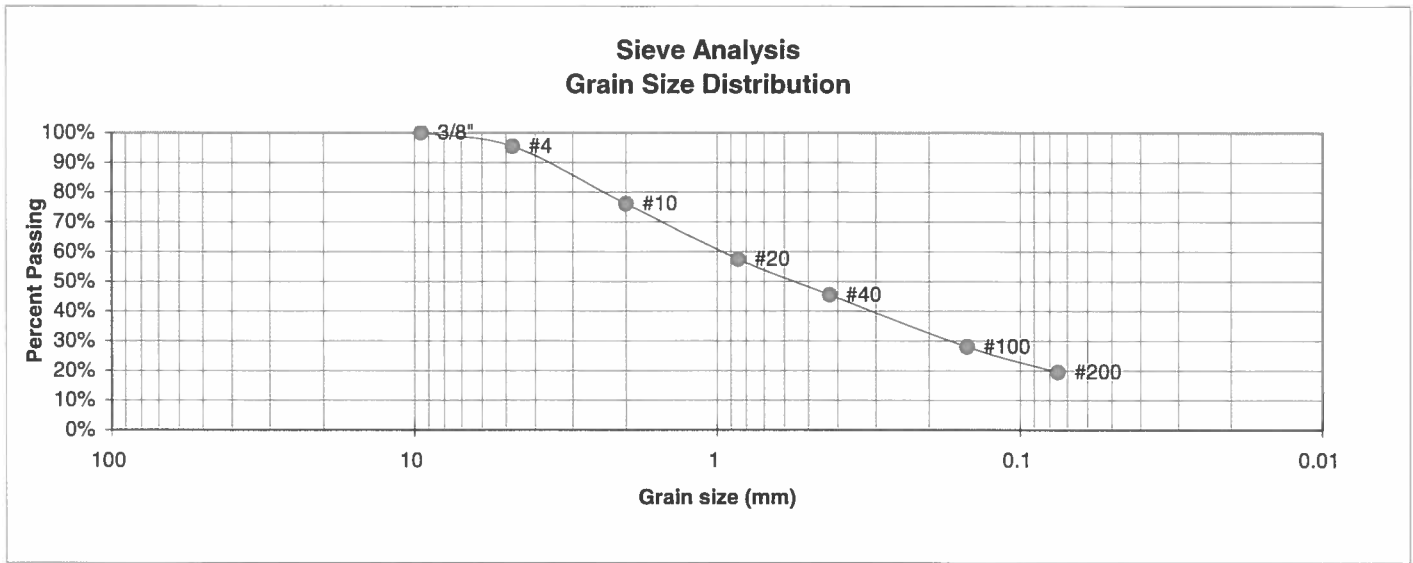

<u>U.S. Sieve #</u>	<u>Percent Finer</u>
3"	
1 1/2"	
3/4"	
1/2"	
3/8"	100.0%
4	95.3%
10	76.1%
20	57.4%
40	45.4%
100	28.0%
200	19.5%

Atterberg Limits  
 Plastic Limit  
 Liquid Limit  
 Plastic Index

Swell  
 Moisture at start  
 Moisture at finish  
 Moisture increase  
 Initial dry density (pcf)  
 Swell (psf)



**ENTECH  
ENGINEERING, INC.**

505 ELKTON DRIVE  
COLORADO SPRINGS, COLORADO 80907

**LABORATORY TEST  
RESULTS**

<u>DRAWN:</u>	<u>DATE:</u>	<u>CHECKED:</u>	<u>DATE:</u>
		<i>[Signature]</i>	4/17/17

JOB NO.:

162442  
FIG NO.:

C-2

BORING NO.	TP-1	UNIFIED CLASSIFICATION	SM-SW	TEST BY	BL
DEPTH(ft)	7-8'	AASHTO CLASSIFICATION		JOB NO.	162442
CLIENT	JEROME HANIGAN				
PROJECT	SILVER NELL				

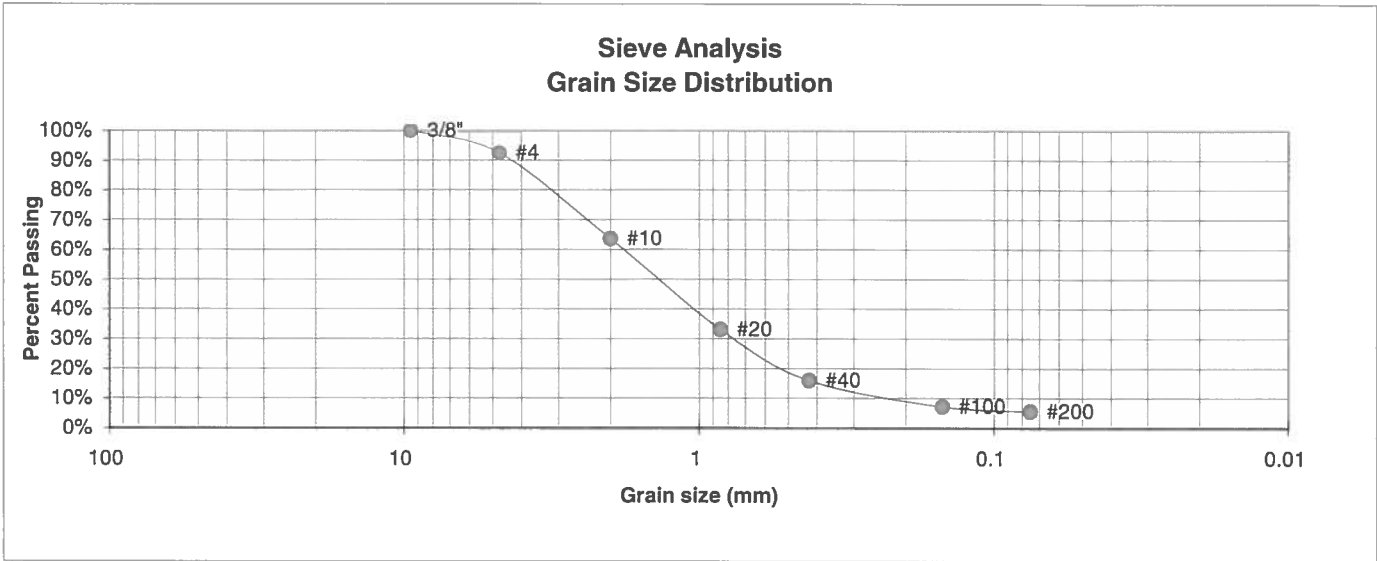

U.S. Sieve #	Percent Finer	Atterberg Limits
3"		Plastic Limit
1 1/2"		Liquid Limit
3/4"		Plastic Index
1/2"		
3/8"	100.0%	
4	92.5%	<u>Swell</u>
10	63.5%	Moisture at start
20	33.0%	Moisture at finish
40	15.8%	Moisture increase
100	7.1%	Initial dry density (pcf)
200	5.5%	Swell (psf)



**ENTECH**  
**ENGINEERING, INC.**

505 ELKTON DRIVE  
COLORADO SPRINGS, COLORADO 80907

### LABORATORY TEST RESULTS

DRAWN:

DATE:

CHECKED:  
LLL

DATE:  
1/27/17

JOB NO.:

162442

FIG NO.:

C-3

BORING NO.	TP-2	<u>UNIFIED CLASSIFICATION</u>	SC	<u>TEST BY</u>	BL
DEPTH(ft)	2-3'	<u>AASHTO CLASSIFICATION</u>		<u>JOB NO.</u>	162442
<u>CLIENT</u>	JEROME HANIGAN				
<u>PROJECT</u>	SILVER NELL				

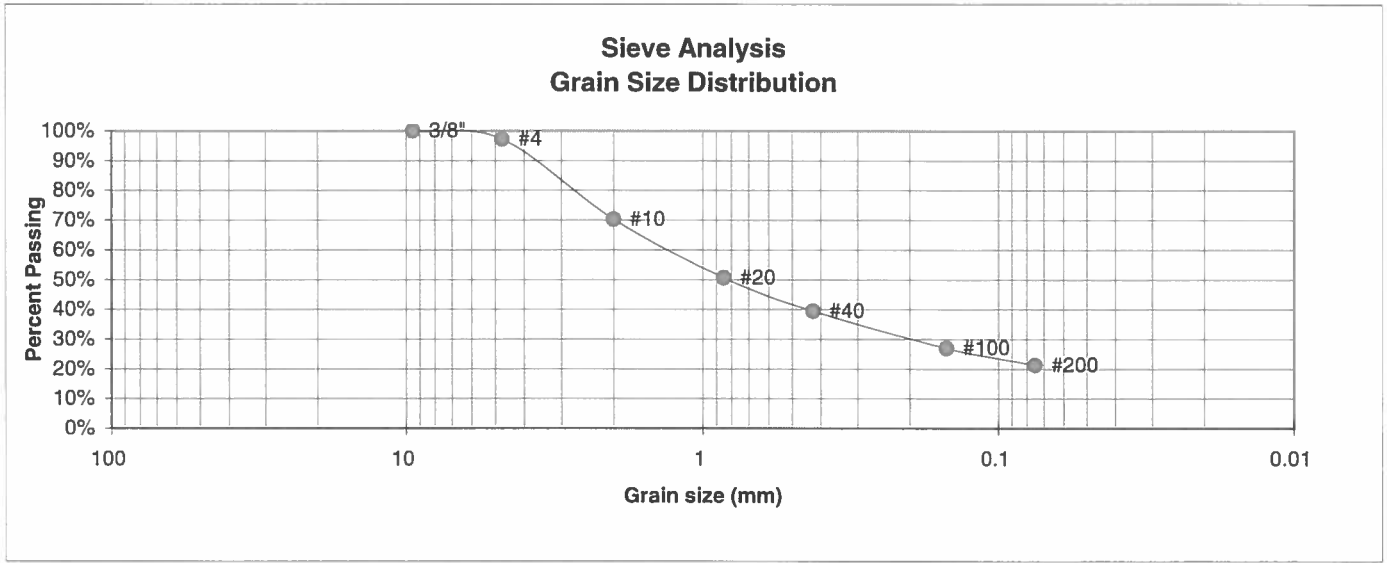

U.S. Sieve #	Percent Finer
3"	
1 1/2"	
3/4"	
1/2"	
3/8"	100.0%
4	97.1%
10	70.2%
20	50.6%
40	39.3%
100	27.0%
200	21.2%

Atterberg Limits  
 Plastic Limit  
 Liquid Limit  
 Plastic Index

Swell  
 Moisture at start  
 Moisture at finish  
 Moisture increase  
 Initial dry density (pcf)  
 Swell (psf)



**ENTECH  
ENGINEERING, INC.**

505 ELKTON DRIVE  
COLORADO SPRINGS, COLORADO 80907

**LABORATORY TEST  
RESULTS**

DRAWN:

DATE:

CHECKED:  
LLL

DATE:  
1/27/17

JOB NO.:

162442

FIG NO.:

C-4

BORING NO.	TP-3	<u>UNIFIED CLASSIFICATION</u>	SC	<u>TEST BY</u>	BL
DEPTH(ft)	2-3'	<u>AASHTO CLASSIFICATION</u>		<u>JOB NO.</u>	162442
CLIENT	JEROME HANIGAN				
PROJECT	SILVER NELL				

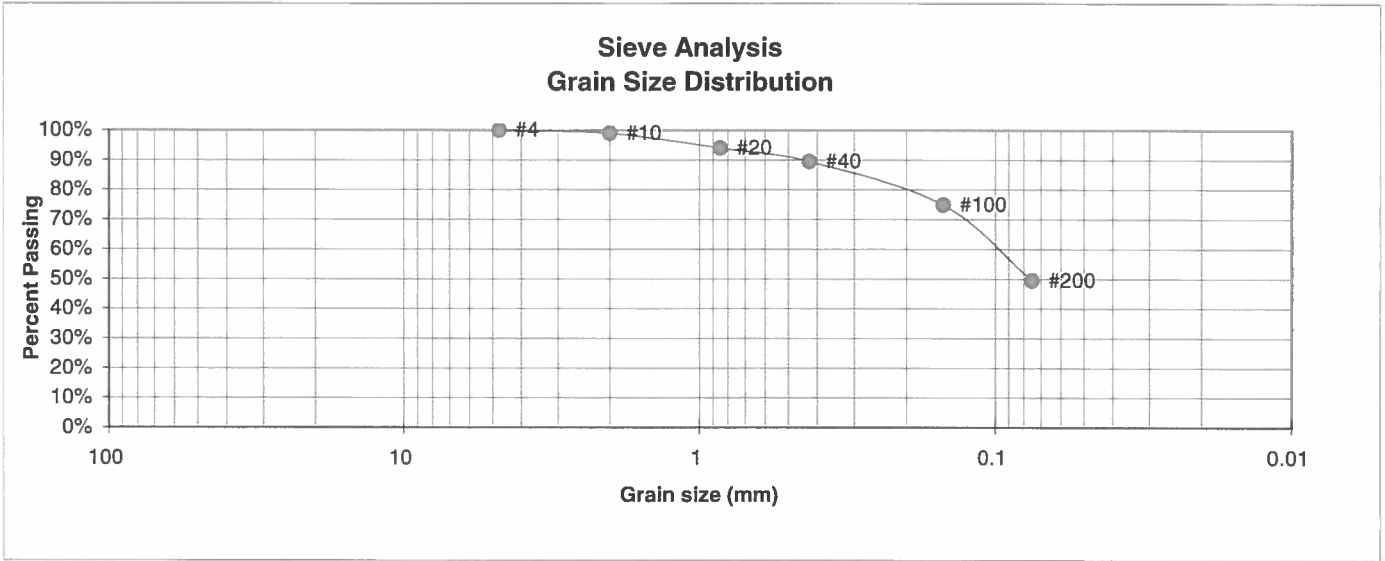

U.S. Sieve #	Percent Finer
3"	
1 1/2"	
3/4"	
1/2"	
3/8"	
4	100.0%
10	99.0%
20	94.0%
40	89.4%
100	74.8%
200	49.4%

Atterberg Limits  
 Plastic Limit  
 Liquid Limit  
 Plastic Index

Swell  
 Moisture at start  
 Moisture at finish  
 Moisture increase  
 Initial dry density (pcf)  
 Swell (psf)



**ENTECH  
ENGINEERING, INC.**

505 ELKTON DRIVE  
COLORADO SPRINGS, COLORADO 80907

**LABORATORY TEST  
RESULTS**

DRAWN:	DATE:	CHECKED: LLL	DATE: 1/27/17
--------	-------	-----------------	------------------

JOB NO.:  
162442  
FIG NO.:  
C-5

<u>UNIFIED CLASSIFICATION</u>	CL	<u>CLIENT</u>	JEROME HANNIGAN & ASSOC.
<u>SOIL TYPE #</u>	2	<u>PROJECT</u>	SILVER NELL & SETTLERS VIEW
<u>TEST BORING #</u>	PH-1	<u>JOB NO.</u>	162442
<u>DEPTH (FT)</u>	10	<u>TEST BY</u>	BL

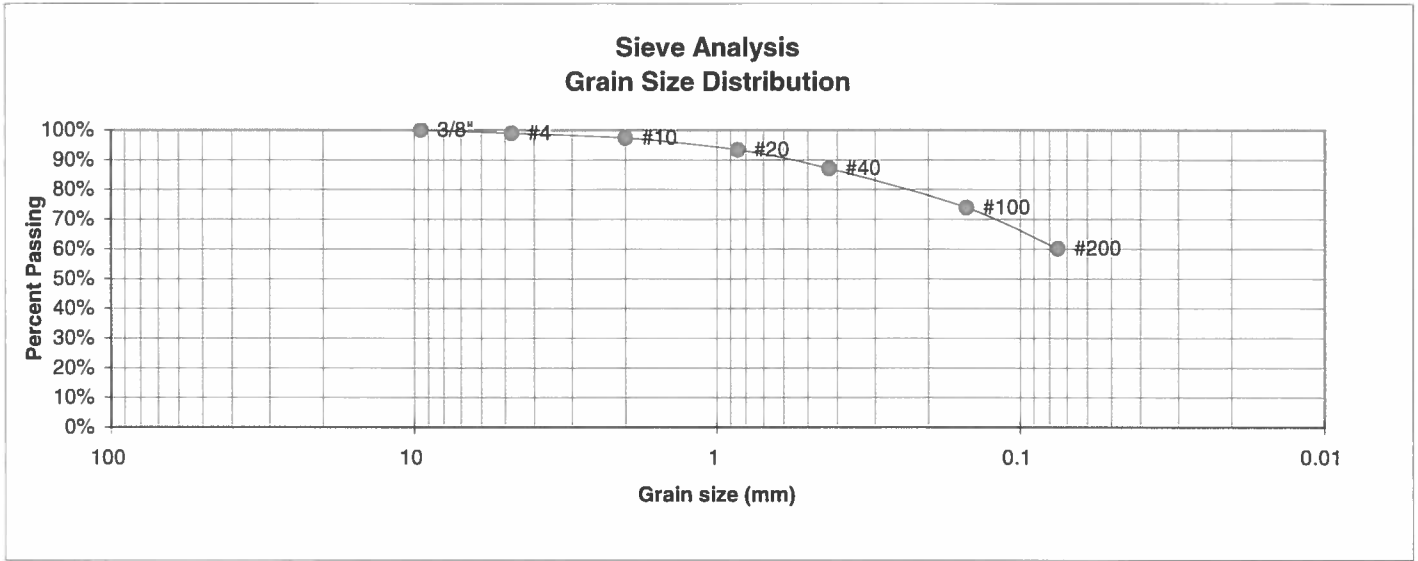

U.S. Sieve #	Percent Finer
3"	
1 1/2"	
3/4"	
1/2"	
3/8"	100.0%
4	99.0%
10	97.3%
20	93.3%
40	87.0%
100	73.9%
200	60.1%

Atterberg Limits  
 Plastic Limit  
 Liquid Limit  
 Plastic Index

Swell  
 Moisture at start  
 Moisture at finish  
 Moisture increase  
 Initial dry density (pcf)  
 Swell (psf)



**ENTECH  
ENGINEERING, INC.**

505 ELKTON DRIVE  
COLORADO SPRINGS, COLORADO 80907

**LABORATORY TEST  
RESULTS**

DRAWN:	DATE:	CHECKED:	DATE:
		<i>[Signature]</i>	1/17/17

JOB NO.:

162442  
FIG NO.:

C-6

<b>UNIFIED CLASSIFICATION</b>	SM	<b>CLIENT</b>	JEROME HANNIGAN & ASSOC.
<b>SOIL TYPE #</b>	3	<b>PROJECT</b>	SILVER NELL & SETTLERS VIEW
<b>TEST BORING #</b>	PH-1	<b>JOB NO.</b>	162442
<b>DEPTH (FT)</b>	15	<b>TEST BY</b>	BL

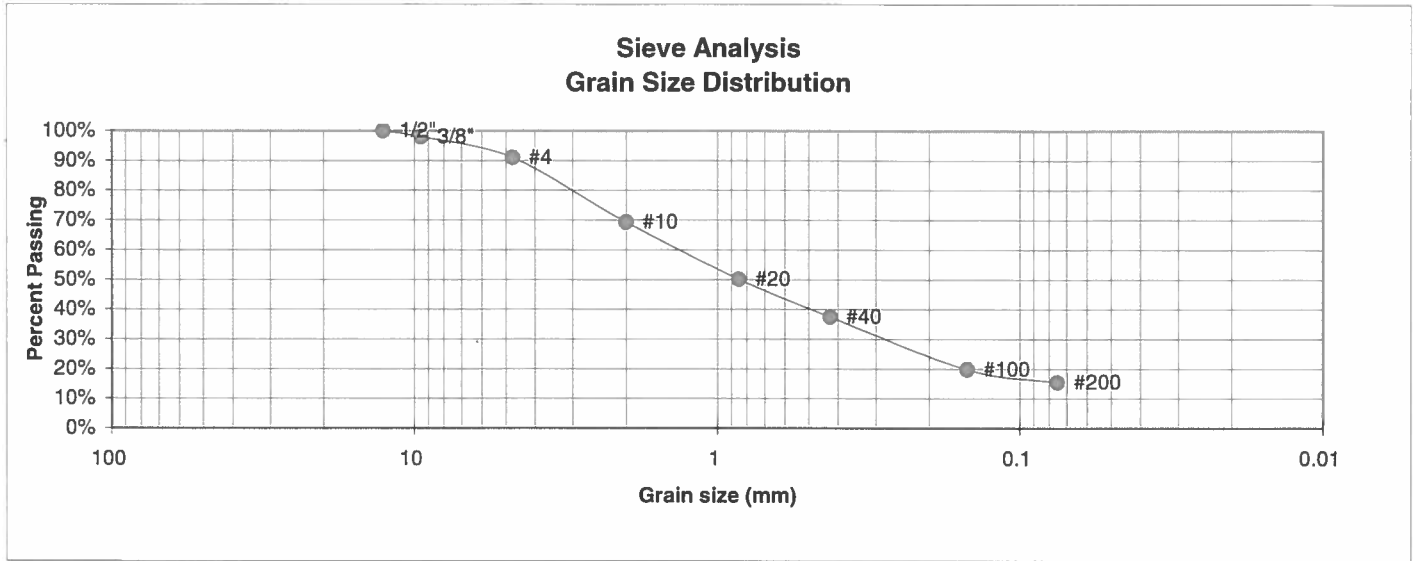

U.S. Sieve #	Percent Finer
3"	
1 1/2"	
3/4"	
1/2"	100.0%
3/8"	98.0%
4	91.0%
10	69.2%
20	50.1%
40	37.5%
100	19.7%
200	15.4%

**Atterberg Limits**  
 Plastic Limit  
 Liquid Limit  
 Plastic Index

**Swell**  
 Moisture at start  
 Moisture at finish  
 Moisture increase  
 Initial dry density (pcf)  
 Swell (psf)



**ENTECH  
ENGINEERING, INC.**

505 ELKTON DRIVE  
COLORADO SPRINGS, COLORADO 80907

**LABORATORY TEST  
RESULTS**

DRAWN:	DATE:	CHECKED:	DATE:
		<i>[Signature]</i>	4/17/17

JOB NO.:

162442  
FIG NO.:

C-7



**CONSOLIDATION TEST RESULTS**

TEST BORING #	1	DEPTH(ft)	10
DESCRIPTION	CL	SOIL TYPE	0
NATURAL UNIT DRY WEIGHT (PCF)			122
NATURAL MOISTURE CONTENT			15.2%
SWELL/CONSOLIDATION (%)			0.0%

JOB NO. 162442  
 CLIENT JEROME HANNIGAN & ASSOC.  
 PROJECT SILVER NELL & SETTLERS VIEW

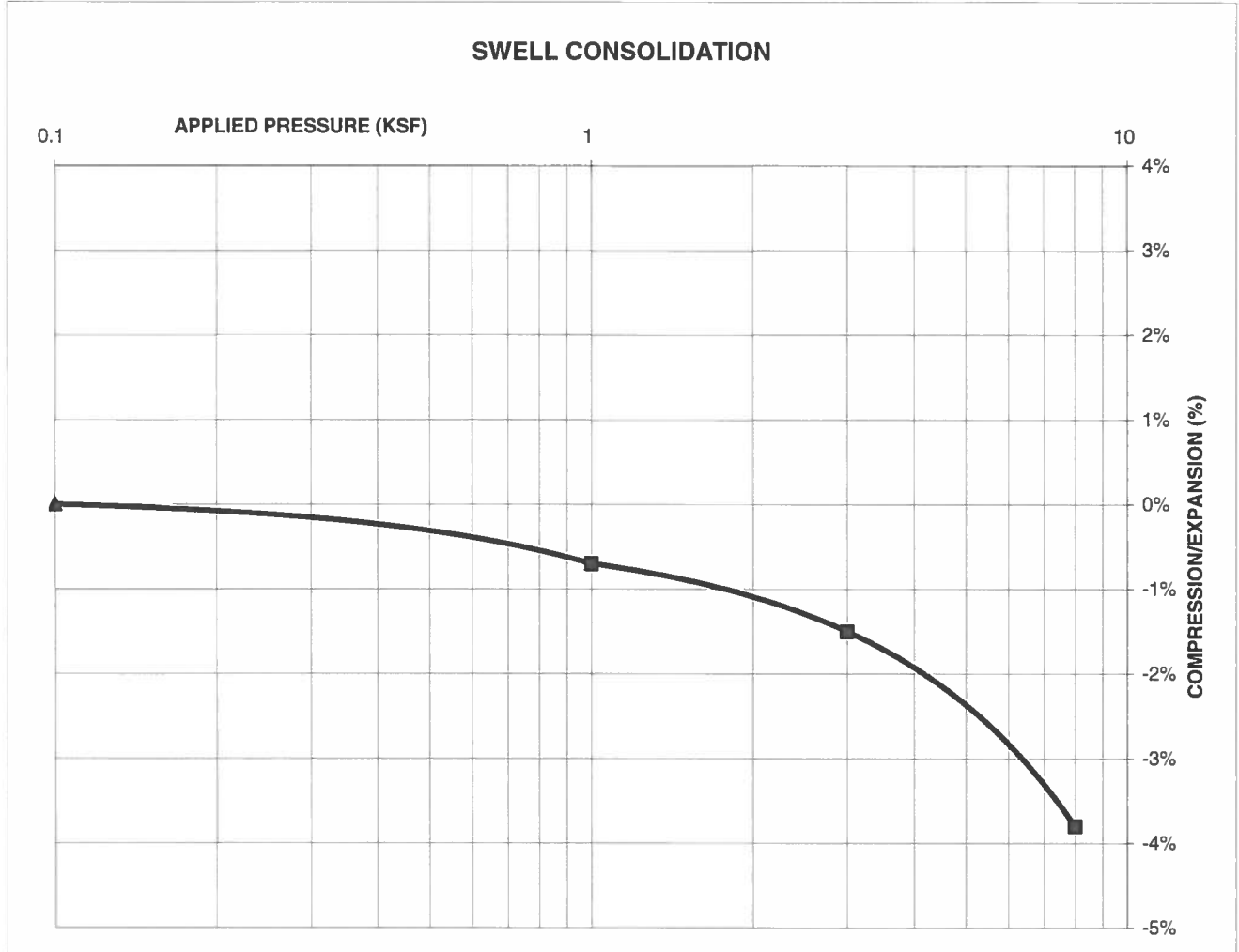

**ENTECH  
 ENGINEERING, INC.**

505 ELKTON DRIVE  
 COLORADO SPRINGS, COLORADO 80907

**SWELL CONSOLIDATION  
 TEST RESULTS**

DRAWN:

DATE:

CHECKED:

DATE:

*[Signature]* 1/17/17

JOB NO.:

162442

FIG NO.:

C-8

## **APPENDIX D: Soil Survey Descriptions**

## El Paso County Area, Colorado

### 25—Elbeth sandy loam, 3 to 8 percent slopes

#### Map Unit Setting

*National map unit symbol:* 367x

*Elevation:* 7,300 to 7,600 feet

*Farmland classification:* Not prime farmland

#### Map Unit Composition

*Elbeth and similar soils:* 85 percent

*Estimates are based on observations, descriptions, and transects of the mapunit.*

#### Description of Elbeth

##### Setting

*Landform:* Hills

*Landform position (three-dimensional):* Side slope

*Down-slope shape:* Linear

*Across-slope shape:* Linear

*Parent material:* Alluvium derived from arkose

##### Typical profile

*A - 0 to 3 inches:* sandy loam

*E - 3 to 23 inches:* loamy sand

*Bt - 23 to 68 inches:* sandy clay loam

*C - 68 to 74 inches:* sandy clay loam

##### Properties and qualities

*Slope:* 3 to 8 percent

*Depth to restrictive feature:* More than 80 inches

*Natural drainage class:* Well drained

*Runoff class:* Medium

*Capacity of the most limiting layer to transmit water (Ksat):*

Moderately high (0.20 to 0.60 in/hr)

*Depth to water table:* More than 80 inches

*Frequency of flooding:* None

*Frequency of ponding:* None

*Available water storage in profile:* Moderate (about 7.1 inches)

##### Interpretive groups

*Land capability classification (irrigated):* None specified

*Land capability classification (nonirrigated):* 4e

*Hydrologic Soil Group:* B

*Hydric soil rating:* No

#### Minor Components

##### Other soils

*Percent of map unit:*

*Hydric soil rating:* No

## **Data Source Information**

Soil Survey Area: El Paso County Area, Colorado

Survey Area Data: Version 14, Sep 23, 2016

## El Paso County Area, Colorado

### 67—Peyton sandy loam, 5 to 9 percent slopes

#### Map Unit Setting

*National map unit symbol:* 369d  
*Elevation:* 6,800 to 7,600 feet  
*Mean annual air temperature:* 43 to 45 degrees F  
*Frost-free period:* 115 to 125 days  
*Farmland classification:* Not prime farmland

#### Map Unit Composition

*Peyton and similar soils:* 85 percent  
*Estimates are based on observations, descriptions, and transects of the mapunit.*

#### Description of Peyton

##### Setting

*Landform:* Hills  
*Landform position (three-dimensional):* Side slope  
*Down-slope shape:* Linear  
*Across-slope shape:* Linear  
*Parent material:* Arkosic alluvium derived from sedimentary rock and/or arkosic residuum weathered from sedimentary rock

##### Typical profile

*A - 0 to 12 inches:* sandy loam  
*Bt - 12 to 25 inches:* sandy clay loam  
*BC - 25 to 35 inches:* sandy loam  
*C - 35 to 60 inches:* sandy loam

##### Properties and qualities

*Slope:* 5 to 9 percent  
*Depth to restrictive feature:* More than 80 inches  
*Natural drainage class:* Well drained  
*Runoff class:* Medium  
*Capacity of the most limiting layer to transmit water (Ksat):*  
Moderately high (0.20 to 0.60 in/hr)  
*Depth to water table:* More than 80 inches  
*Frequency of flooding:* None  
*Frequency of ponding:* None  
*Available water storage in profile:* Moderate (about 7.3 inches)

##### Interpretive groups

*Land capability classification (irrigated):* None specified  
*Land capability classification (nonirrigated):* 4e  
*Hydrologic Soil Group:* B  
*Ecological site:* Sandy Divide (R049BY216CO)  
*Hydric soil rating:* No

### **Minor Components**

#### **Other soils**

*Percent of map unit:*

*Hydric soil rating:* No

#### **Pleasant**

*Percent of map unit:*

*Landform:* Depressions

*Hydric soil rating:* Yes

### **Data Source Information**

Soil Survey Area: El Paso County Area, Colorado

Survey Area Data: Version 14, Sep 23, 2016

## El Paso County Area, Colorado

### 92—Tomah-Crowfoot loamy sands, 3 to 8 percent slopes

#### Map Unit Setting

*National map unit symbol:* 36b9  
*Elevation:* 7,300 to 7,600 feet  
*Farmland classification:* Not prime farmland

#### Map Unit Composition

*Tomah and similar soils:* 50 percent  
*Crowfoot and similar soils:* 30 percent  
*Estimates are based on observations, descriptions, and transects of the mapunit.*

#### Description of Tomah

##### Setting

*Landform:* Alluvial fans, hills  
*Landform position (three-dimensional):* Side slope, crest  
*Down-slope shape:* Linear  
*Across-slope shape:* Linear  
*Parent material:* Alluvium derived from arkose and/or residuum weathered from arkose

##### Typical profile

*A - 0 to 10 inches:* loamy sand  
*E - 10 to 22 inches:* coarse sand  
*C - 48 to 60 inches:* coarse sand

##### Properties and qualities

*Slope:* 3 to 8 percent  
*Depth to restrictive feature:* More than 80 inches  
*Natural drainage class:* Well drained  
*Runoff class:* Medium  
*Capacity of the most limiting layer to transmit water (Ksat):*  
Moderately high to high (0.60 to 2.00 in/hr)  
*Depth to water table:* More than 80 inches  
*Frequency of flooding:* None  
*Frequency of ponding:* None  
*Available water storage in profile:* Very low (about 2.0 inches)

##### Interpretive groups

*Land capability classification (irrigated):* None specified  
*Land capability classification (nonirrigated):* 4e  
*Hydrologic Soil Group:* B  
*Ecological site:* Sandy Divide (R049BY216CO)  
*Hydric soil rating:* No

#### Description of Crowfoot

##### Setting

*Landform:* Alluvial fans, hills

*Landform position (three-dimensional):* Side slope, crest  
*Down-slope shape:* Linear  
*Across-slope shape:* Linear  
*Parent material:* Alluvium

**Typical profile**

*A - 0 to 12 inches:* loamy sand  
*E - 12 to 23 inches:* sand  
*Bt - 23 to 36 inches:* sandy clay loam  
*C - 36 to 60 inches:* coarse sand

**Properties and qualities**

*Slope:* 3 to 8 percent  
*Depth to restrictive feature:* More than 80 inches  
*Natural drainage class:* Well drained  
*Runoff class:* Medium  
*Capacity of the most limiting layer to transmit water (Ksat):*  
Moderately high to high (0.60 to 2.00 in/hr)  
*Depth to water table:* More than 80 inches  
*Frequency of flooding:* None  
*Frequency of ponding:* None  
*Available water storage in profile:* Low (about 4.7 inches)

**Interpretive groups**

*Land capability classification (irrigated):* None specified  
*Land capability classification (nonirrigated):* 4e  
*Hydrologic Soil Group:* B  
*Ecological site:* Sandy Divide (R049BY216CO)  
*Hydric soil rating:* No

**Minor Components**

**Other soils**

*Percent of map unit:*  
*Hydric soil rating:* No

**Pleasant**

*Percent of map unit:*  
*Landform:* Depressions  
*Hydric soil rating:* Yes

**Data Source Information**

Soil Survey Area: El Paso County Area, Colorado  
Survey Area Data: Version 14, Sep 23, 2016



## **APPENDIX E: Percolation Test Results**

Client: Jerom Hannigan and Associates  
 Test Location: Silver Nell and Settlers View

Job Number: 162442

**PERCOLATION HOLES #1**

Date Holes Prepared: 1/11/2017

Date Hole Completed: 1/12/2017

Hole No. 1

Depth: 34"

Hole No. 2

Depth: 34"

Hole No. 3

Depth: 35"

Hole No. 1			Hole No. 2			Hole No. 3		
Trial	Time (min.)	Water Level Change (in.)	Trial	Time (min.)	Water Level Change (in.)	Trial	Time (min.)	Water Level Change (in.)
1	10	1/8	1	10	1/8	1	10	1/8
2	10	1/8	2	10	1/8	2	10	1/8
3	10	1/8	3	10	1/8	3	10	1/8

Perc Rate (min./in.): 80

Perc Rate (min./in.): 80

Perc Rate (min./in.): 80

Average Perc Rate (min./in.) 80\*

**PROFILE HOLE**

Date Profile Hole Completed: 1/11/2017

Depth	Visual Classification	Remarks
0-9'	Sand, silty to clayey, fine to coarse grained, tan	
9-11'	Clay, very sandy, brown	Sandstone Bedrock at 11'
11-15'	Sandstone, silty, fine to coarse grained, tan	Groundwater at 15'
	25 Blows / ft. @ 2'	
	16 Blows / ft. @ 4'	
	10 Blows / ft. @ 9'	

LTAR = 0.20 gallons per square foot per day.

Remarks:

\* - Due to slow percolation rate, additional drilling or a designed system is recommended

GPS Coordinates: 39° 04' 48.8" N, 104° 44' 27.7" W

Observer: Dan Crea

By:

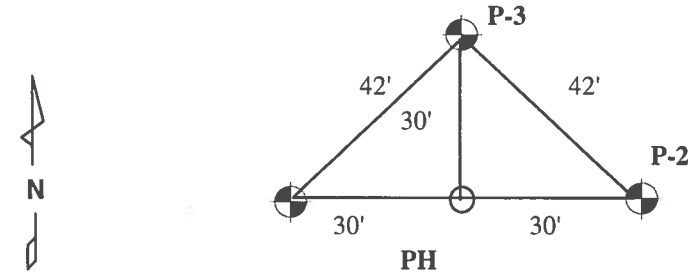

N.T.S.



**ENTECH ENGINEERING, INC.**

505 ELKTON DRIVE  
 COLORADO SPRINGS, COLORADO 80907

**PERCOLATION TEST RESULTS**

DRAWN: DATE: CHECKED: DATE: *[Signature]* 1/17/17

JOB NO.:

162442

FIG NO.:

E-1

Client: Jerom Hannigan and Associates  
 Test Location: Silver Nell and Settlers View

Job Number: 162442

**PERCOLATION HOLES #2**

Date Holes Prepared: 1/11/2017

Date Hole Completed: 1/12/2017

Hole No. 1  
 Depth: 35"

Hole No. 2  
 Depth: 38"

Hole No. 3  
 Depth: 40"

Hole No. 1			Hole No. 2			Hole No. 3		
Trial	Time (min.)	Water Level Change (in.)	Trial	Time (min.)	Water Level Change (in.)	Trial	Time (min.)	Water Level Change (in.)
1	10	3/8	1	10	1/8	1	10	1/8
2	10	3/8	2	10	1/8	2	10	1/8
3	10	3/4	3	10	1/8	3	10	1/8

Perc Rate (min./in.): 13

Perc Rate (min./in.): 80

Perc Rate (min./in.): 80

Average Perc Rate (min./in.) 58

**PROFILE HOLE**

Date Profile Hole Completed: 1/11/2017

Depth 0-15'      Visual Classification Sand, silty to clayey, fine to coarse grained, tan

Remarks  
 No Bedrock  
 No Groundwater

11 Blows / ft. @ 2'  
 9 Blows / ft. @ 4'  
 18 Blows / ft. @ 9'

LTAR = 0.35 gallons per square foot per day.

Remarks:

GPS Coordinates: 39° 04' 47.2" N, 104° 44' 37.0" W

Observer: Graham Espenlaub      By:

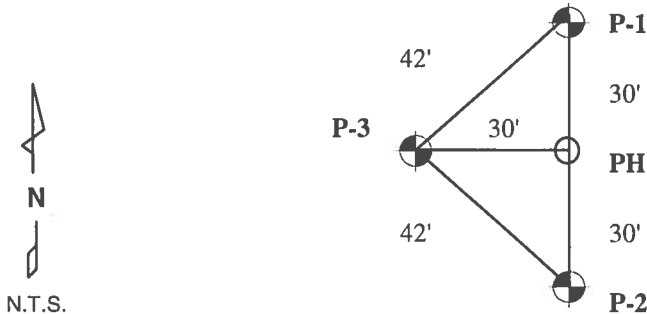

**ENTECH ENGINEERING, INC.**

505 ELKTON DRIVE  
 COLORADO SPRINGS, COLORADO 80907

**PERCOLATION TEST RESULTS**

DRAWN:      DATE:      CHECKED: *W*      DATE: *1/17/17*

JOB NO.: 162442  
 FIG NO.: E-2

Client: Jerom Hannigan and Associates  
 Test Location: Silver Nell and Settlers View

Job Number: 162442

**PERCOLATION HOLES #3**

Date Holes Prepared: 1/11/2017

Date Hole Completed: 1/12/2017

Hole No. 1

Depth: 35"

Hole No. 2

Depth: 38"

Hole No. 3

Depth: 40"

Hole No. 1			Hole No. 2			Hole No. 3		
Trial	Time (min.)	Water Level Change (in.)	Trial	Time (min.)	Water Level Change (in.)	Trial	Time (min.)	Water Level Change (in.)
1	10	3/4	1	10	1/2	1	10	1/4
2	10	3/8	2	10	3/8	2	10	3/8
3	10	1/8	3	10	1/4	3	10	3/8

Perc Rate (min./in.): 80

Perc Rate (min./in.): 40

Perc Rate (min./in.): 27

Average Perc Rate (min./in.) 49

**PROFILE HOLE**

Date Profile Hole Completed: 1/11/2017

Depth

0-15'

Visual Classification

Sand, silty to clayey, fine to coarse grained, tan

Remarks

No Bedrock  
 No Groundwater

16 Blows / ft. @ 2'  
 10 Blows / ft. @ 4'  
 12 Blows / ft. @ 9'

LTAR = 0.35 gallons per square foot per day.

Remarks:

GPS Coordinates: 39° 04' 45.0" N, 104° 44' 41.8" W

Observer: Graham Espenlaub

By:

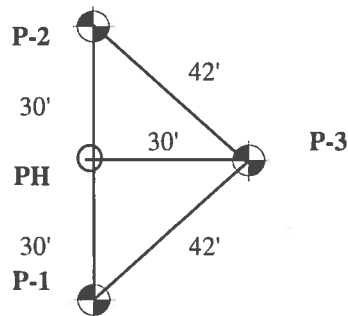
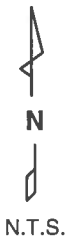

**ENTECH  
 ENGINEERING, INC.**

505 ELKTON DRIVE  
 COLORADO SPRINGS, COLORADO 80907

**PERCOLATION TEST RESULTS**

DRAWN:	DATE:	CHECKED:	DATE:
		<i>[Signature]</i>	1/27/17

JOB NO.:

162442

FIG NO.:

E-3