



ENTECH
ENGINEERING, INC.

505 ELKTON DRIVE
COLORADO SPRINGS, CO 80907
PHONE (719) 531-5599

**WASTEWATER STUDY
RETREAT AT TIMBERRIDGE FILING NO. 4
PARCEL NO. 52220-00-023
EL PASO COUNTY, COLORADO**

Prepared for:
**TimberRidge Development Group, LLC
2138 Flying Horse Club Drive
Colorado Springs, CO 80921**

Attn: Loren Moreland

December 21, 2023

Respectfully Submitted,

ENTECH ENGINEERING, INC.

Reviewed by:

Logan L. Langford, P.G.
Geologist

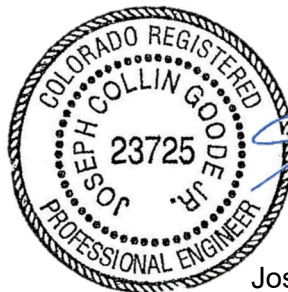

Joseph C. Goode Jr., P.E.
President

LLL

Table of Contents

1 SUMMARY..... 1

2 GENERAL SITE CONDITIONS AND PROJECT DESCRIPTION 2

3 SCOPE OF THE REPORT 2

4 FIELD INVESTIGATION 2

5 SOIL, GEOLOGY, AND ENGINEERING GEOLOGY..... 3

 5.1 General Geology 3

 5.2 Soil Conservation Survey 4

 5.3 Site Stratigraphy 4

 5.4 Soil Conditions 5

 5.5 Groundwater 6

6 ON-SITE WASTEWATER TREATMENT 6

7 CLOSURE..... 7

8 REFERENCES..... 9

FIGURES

- Figure 1: Vicinity Map
- Figure 2: USGS Map
- Figure 3: Exploration and Site Plan
- Figure 4: Soil Survey Map
- Figure 5: Geologic Map of the Falcon NW Quadrangle
- Figure 6: Geology Map/Engineering Geology
- Figure 7: Floodplain Map
- Figure 8: Typical Perimeter Drain Details
- Figure 9: Underslab Drainage Layer (Capillary Break)
- Figure 10: Interceptor Drain Detail
- Figure 11: Overexcavation Drain Detail

- APPENDIX A: Site Photographs
- APPENDIX B: Test Boring and Test Pit Logs
- APPENDIX C: Laboratory Test Results
- APPENDIX D: Soil Survey Descriptions

1 SUMMARY

Project Location

The project lies in portions of the SW $\frac{1}{4}$ of Section 22 and the NE $\frac{1}{4}$ of Section 28, Township 12 South, Range 65 West of the 6th Principal Meridian in El Paso County, Colorado. The site is located approximately 3 miles northeast of Colorado Springs, Colorado.

Project Description

Ten rural residential 2.5+ acre lots are proposed on the 34.92-acre site. The proposed rural residential lots will be serviced by individual on-site wastewater treatment systems and individual water wells.

Scope of Report

This report presents the results of our geologic evaluation and treatment of engineering geologic hazard study.

Land Use and Engineering Geology

This site was found to be suitable for the proposed development. Areas were encountered where the geologic conditions will impose some constraints on development and land use. These include areas of expansive soils, shallow bedrock, and seasonal shallow groundwater and potentially seasonally shallow groundwater areas. Based on the proposed development plan, it appears that these areas will have some impact on the development. These conditions will be discussed in greater detail in the report.

In general, it is our opinion that the development can be achieved if the observed geologic conditions on site are either avoided or properly mitigated. All recommendations are subject to the limitations discussed in the report.

2 GENERAL SITE CONDITIONS AND PROJECT DESCRIPTION

The site is located in portions of the SW¼ of Section 22 and the NE¼ of Section 28, Township 15 South, Range 65 West of the 6th Principal Meridian in El Paso County, Colorado. The site is located approximately 3 miles northeast of Colorado Springs, Colorado, at Vollmer Road and Arroya Lane. The location of the site is as shown on the Vicinity Map, Figure 1.

Generally, the topography of the site is gradually to moderately sloping to the southwest towards Sand Creek. Minor drainage swales are located across the site that flow in a westerly direction. Water was not observed in the drainages on-site at the time of this investigation. The site boundaries are indicated on the USGS Map, Figure 2. Previous land uses have included equipment storage, a fill borrow area, and grazing and pasture land. The site contains primarily field grasses, weeds, cacti, and yuccas, mountain mahogany, and ponderosa pine. Site photographs, taken September 13, 2023, are included in Appendix A.

Ten rural residential 2.5+ acre lots are proposed on the 34.92-acre site. Preliminary grading plans indicate the site grading will be limited to the proposed roadway and detention pond in the southwestern corner of the site. The proposed grading is shown on Exploration and Site Plan presented in Figure 3.

3 SCOPE OF THE REPORT

The scope of the report includes a general geologic analysis utilizing published geologic data. Detailed site-specific mapping will be conducted to obtain general information in respect to major geographic and geologic features, geologic descriptions and their effects on the development of the property.

4 FIELD INVESTIGATION

Our field investigation consisted of the preparation of a geologic map of any bedrock features and significant surficial deposits. The Natural Resource Conservation Service (NRCS), previously the Soil Conservation Service (SCS) survey was also reviewed to evaluate the site. The position of mappable units within the subject property are shown on the Geologic Map. Our mapping procedures involved both field reconnaissance and measurements and air photo reconnaissance and interpretation. The same mapping procedures have also been utilized to produce the

Engineering Geology Map which identified pertinent geologic conditions affecting development. The field mapping was performed by personnel of Entech Engineering, Inc. on August 9, 2023.

A Geologic Hazard Study was previously performed by Entech Engineering, Inc. for the Retreat at TimberRidge, April 17, 2017 (Reference 1). Test borings and test pits from the previous investigation were utilized for this report. The location of the test borings and test pits are indicated on Figures 3 and 6. Information from the report was used in evaluating the site. The Test Boring and Test Pit Logs are presented in Appendix B, and Summarized on Table B-1. Results of this testing will be discussed later in this report.

Laboratory testing was also performed on some of the soils to classify and determine the soils engineering characteristics. Laboratory tests included grain-size analysis ASTM D-422, Atterberg Limits ASTM D-4318, volume change testing using Swell/Consolidation test. Sulfate testing was performed on select samples to evaluate potential for below grade concrete degradation due to sulfate attack. Results of the laboratory testing are included in Appendix C. A Summary of Laboratory Test Results is presented in Table C-1.

5 SOIL, GEOLOGY, AND ENGINEERING GEOLOGY

5.1 General Geology

Physiographically, the site lies in the western portion of the Great Plains Physiographic Province. Approximately 12 miles to the west is a major structural feature known as the Rampart Range Fault. This fault marks the boundary between the Great Plains Physiographic Province and the Southern Rocky Mountain Province. The site exists within the southeastern edge of a large structural feature known as the Denver Basin. Bedrock in the area tends to be very gently dipping in a northeasterly direction (Reference 1). The rocks in the area of the site are sedimentary in nature and typically Upper Cretaceous in age. The bedrock underlying the site consists of the Dawson Formation. Overlying this formation are unconsolidated deposits of man-made, and alluvial soils of Quaternary Age. The alluvial soils were deposited by water on site and as stream deposits along the drainages on-site. The site's stratigraphy will be discussed in more detail in Section 5.3.

5.2 Soil Conservation Survey

The Natural Resource Conservation Service (Reference 2), previously the Soil Conservation Service (Reference 3) has mapped three soil types on the site (Figure 4). In general, the soils classify as gravelly loamy sand and coarse sandy loam. The soils are described as follows:

<u>Type</u>	<u>Description</u>
40	Kettle gravelly loamy sand, 3 – 8% slopes
41	Kettle gravelly loamy sand, 8 – 40% slopes
71	Pring coarse sandy loam, 3 – 8% slopes

Complete descriptions of each soil type are presented in Appendix D. The soils have generally been described to have moderate to moderately rapid permeabilities. Possible hazards with soil erosion are present on the site. The erosion potential can be controlled with vegetation. The majority of the soils have been described to have slight to moderate erosion hazards.

5.3 Site Stratigraphy

The Geologic Map of the Falcon NW Quadrangle showing the site is presented in Figure 5 (Reference 5). The Geology Map prepared for the site is presented in Figure 6. Two mappable units were identified on this site which are described as follows:

Qal Recent alluvium of Holocene Age: These are recent deposits that have been deposited along the drainages on-site.

Tkd Dawson Formation of Tertiary to Cretaceous Age: The Dawson formation typically consists of arkosic sandstone with interbedded fine-grained sandstone, siltstone and claystone. Overlying this formation is a variable layer of residual and/or colluvial soils. The residual soils were derived from the in-situ weathering of the bedrock materials on-site. The colluvial soils have been transported by the action of sheetwash and gravity. These soils consisted of silty to clayey sands and sandy clays

The bedrock underlying the site consists of the Dawson Formation of Tertiary to Cretaceous Age. The Dawson Formation typically consists of arkosic sandstone with interbedded fine-grained sandstone, siltstone and claystone. Overlying this formation are variable layers of alluvial deposits, and residual soil. The residual soils were derived from the in-situ weathering of the bedrock materials on-site. These soils consisted of silty to clayey sands and sandy clays.

The soils listed above were mapped from site-specific mapping, the *Geologic Map of the Falcon NW Quadrangle* distributed by the Colorado Geological Survey in 2003 (Reference 5), the *Geologic Map of the Colorado Springs-Castle Rock Area*, distributed by the US Geological Survey in 1979 (Reference 6), and the *Geologic Map of the Pueblo 1^o x 2^o Quadrangle*, distributed by the US Geological Survey in 1978 (Reference 7). The test borings and test pits were also used in evaluating the site and are included in Appendix B. The Geology Map prepared for the site is presented in Figure 6.

5.4 Soil Conditions

The soils encountered in the Test Borings can be grouped into three general soil types. The soils were classified using the Unified Soil Classification System (USCS).

Soil Type 1 clayey to very clayey sand and silty to slightly silty sand (SC, SM, SM-SW), encountered in both of Test Borings and all of the test pits at the existing ground surface and extending to depths ranging from 1 foot to 14 feet bgs. These soils were encountered at loose to dense states and at moist conditions. The majority of the soils were encountered and medium dense states. Samples tested had 11 to 34 percent passing the No. 200 Sieve.

Soil Type 2 silty sandstone and clayey to very clayey sandstone (SM, SC), encountered in both of Test Borings and all of the Test Pits at depths ranging from 1 foot to 14 feet bgs and extending to the termination of the test borings (15 to 20 feet). The sandstone was encountered at dense to very dense states and at moist conditions. Samples tested had 48 percent passing the No. 200 Sieve. Swell/Consolidation Testing on a sample of the very clayey sandstone resulted in a swell of 0.2 percent, which is in the low expansion range.

Soil Type 3 sandy claystone and siltstone (CL, MH), encountered in Test Pit No. 2 at depths ranging from 5 feet and extended to the termination test pit (8 feet). The claystone and siltstone were encountered at hard consistencies and at moist conditions. Samples tested had 60 to 77 percent passing the No. 200 Sieve. FHA Swell Testing resulted in an expansion pressure of 1280 psf, which is in the moderate expansion range.

The Test Boring Logs are presented in Appendix B. Laboratory Test Results are presented in Appendix C, and a Summary of Laboratory Test Results is presented in Table C-1.

5.5 Groundwater

Groundwater was encountered in test borings which were drilled to depths of 15 to 20 feet. Signs of seasonally occurring groundwater were observed in TP-2 at a depth of 5 feet. These areas are discussed in the following section. Fluctuation in groundwater conditions may occur due to variations in rainfall and other factors not readily apparent at this time. It should be noted that in the sandy materials on-site, some groundwater conditions might be encountered due to the variability in the soil profile. Isolated sand and gravel layers within the soils, sometimes only a few feet in thickness and width, can carry water in the subsurface. Groundwater may also flow on top of the underlying bedrock. Builders and planners should be cognizant of the potential for the occurrence of such subsurface water features during construction on-site and deal with each individual problem as necessary at the time of construction.

6 ON-SITE WASTEWATER TREATMENT

The site was evaluated for individual on-site wastewater treatment systems in accordance with the El Paso Land Development Code. Four (4) tactile test pits were previously excavated on the site. The test pits were placed in potential locations of future systems. The approximate locations of the Test Pits are indicated in Figure 3, and on the Septic Suitability Map, Figure 8. Test Pit Logs and Laboratory Test Results in Appendices B and C.

The Natural Resource Conservation Service (Reference 5), previously the Soil Conservation Service (Reference 6) has been mapped with three soil descriptions. The Soil Survey Map (Reference 5) is presented in Figure 4, and the Soil Survey Descriptions are presented in Appendix D. The soils are described as having slow to rapid percolation rates. The majority of the soils have been described to have moderate permeabilities.

Drainage areas mapped with potential seasonally and seasonally shallow groundwater are located on the proposed lots. In these areas a 25-foot setback for the soil treatment area will be required. This will limit the potential buildable areas on the lots depending on the final size of the anticipated OWTS. Signs of seasonally occurring groundwater were observed in the Test Pit No. 2 at 5 feet. Weathered bedrock was encountered at approximately 1 to 3.5 feet in the test pits.

Soils encountered in the tactile test pits consisted of sandy loam, gravelly sandy loam, and sandy clay loam overlying highly weathered to weathered clayey to silty sandstone and claystone. The limiting layers encountered in the test pits are gravelly sandy loam (2A – R-1), sandy clay loam (Soil Type 3A), sandstone (gravelly sandy clay when classified as a soil, Soil Type 4A), and claystone (sandy clay when classified as a soil, Soil Type 4A and 5). The soil types correspond to LTAR values ranging from 0.80 to 0.10 gallons per day per square foot. **Additional investigation may identify areas where suitable conventional systems could be used on the lots.**

In summary, it is our opinion the site is suitable for individual on-site wastewater treatment systems (OWTS) and that contamination of surface and subsurface water resources should not occur provided the OWTS sites are evaluated and installed according to El Paso County and State Guidelines and properly maintained. Based on the testing performed as part of this investigation designed systems should be anticipated for new the lots. A Septic Suitability Map is presented in Figure 8. OWTS sites should not be located within defined drainages. Individual soil testing is required on the lots prior to construction. Absorption fields must be located a minimum of 100 feet from any well, including those on adjacent properties. Absorption fields must also be located a minimum of 50 feet from any drainages, floodplains or ponded areas and 25 feet from dry gulches.

7 CLOSURE

It is our opinion that the existing geologic engineering and geologic conditions will impose some constraints on development and construction of the site. Most of these conditions can be mitigated through proper engineering design and construction practices. The proposed development and use are consistent with anticipated geologic and engineering geologic conditions.

It should be pointed out that because of the nature of data obtained by random sampling of such variable and non-homogeneous materials as soil and rock, it is important that we be informed of any differences observed between surface and subsurface conditions encountered in construction and those assumed in the body of this report. Individual investigations for building sites will be required prior to construction. Construction and design personnel should be made familiar with the contents of this report. Reporting such discrepancies to Entech Engineering, Inc.

soon after they are discovered would be greatly appreciated and could possibly help avoid construction and development problems.

This report has been prepared for TimberRidge Development Group, LLC for application to the proposed project in accordance with generally accepted geologic soil and engineering practices. No other warranty expressed or implied is made.

We trust that this report has provided you with all the information that you required. Should you require additional information, please do not hesitate to contact Entech Engineering, Inc.

8 REFERENCES

1. Entech Engineering, Inc. April 12, 202017. *Soil, Geology, and Geologic Hazard Study, The Retreat at TimberRidge 2.5+ Acre Lots, Vollmer Road and Arroya Lane, El Paso County, Colorado*. Entech Job No. 170209.
2. Scott, Glen R., Taylor, Richard B., Epis, Rudy C., and Wobus, Reinhard A. 1978. *Geologic Structure Map of the Pueblo 1° x 2° Quadrangle, North-Central Colorado*. Sheet 2. U.S. Geologic Survey. Map I-1022.
3. Natural Resource Conservation Service, September 22, 2015. *Web Soil Survey*. United States Department Agriculture, <http://websoilsurvey.sc.egov.usda.gov/App/HomePage.htm>.
4. United States Department of Agriculture Soil Conservation Service. June 1981. *Soil Survey of El Paso County Area, Colorado*.
5. Madole, Richard F., 2003. *Geologic Map of the Falcon NW Quadrangle, El Paso County, Colorado*. Colorado Geological Survey. Open-File Report 03-8.
6. Trimble, Donald E. and Machette, Michael N. 1979. *Geologic Map of the Colorado Springs-Castle Rock Area, Front Range Urban Corridor, Colorado*. USGS, Map I-857-F.
7. Scott, Glen R., Taylor, Richard B., Epis, Rudy C., and Wobus, Reinhard A. 1978. *Geologic Map of the Denver 1° x 2° Quadrangle, North-Central Colorado*. U.S. Geologic Survey. Map 1-1022.
8. Federal Emergency Management Agency. December 7, 2018. *Flood Insurance Rate Maps for El Paso County, Colorado and Incorporated Areas*. Map Number 08041CO535G.
9. Kirkman, Robert M. and Rogers, William P. 1981. *Earthquake Potential in Colorado*. Colorado Geological Survey. Bulletin 43.
10. Colorado Geological Survey. 1991. *Results of the 1987-88 EPA Supported Radon Study in Colorado*. Open-file Report 91-4.
11. El Paso County Planning Development. December 1995. *El Paso County Aggregate Resource Evaluation Maps*.
12. Schwochow, S.D.; Shroba, R.R. and Wicklein, P.C. 1974. *Atlas of Sand, Gravel, and Quarry Aggregate Resources, Colorado Front Range Counties*. Colorado Geological Survey. Special Publication 5-B.
13. Keller, John W.; TerBest, Harry and Garrison, Rachel E. 2003. *Evaluation of Mineral and Mineral Fuel Potential of El Paso County State Mineral Lands Administered by the Colorado State Land Board*. Colorado Geological Survey. Open-File Report 03-07.

FIGURES



VICINITY MAP

RETREAT AT TIMBERRIDGE FIL. NO. 4
EL PASO COUNTY, CO
TIMBERRIDGE DEVELOPMENT GROUP, LLC

JOB NO.
231468

FIG. 1

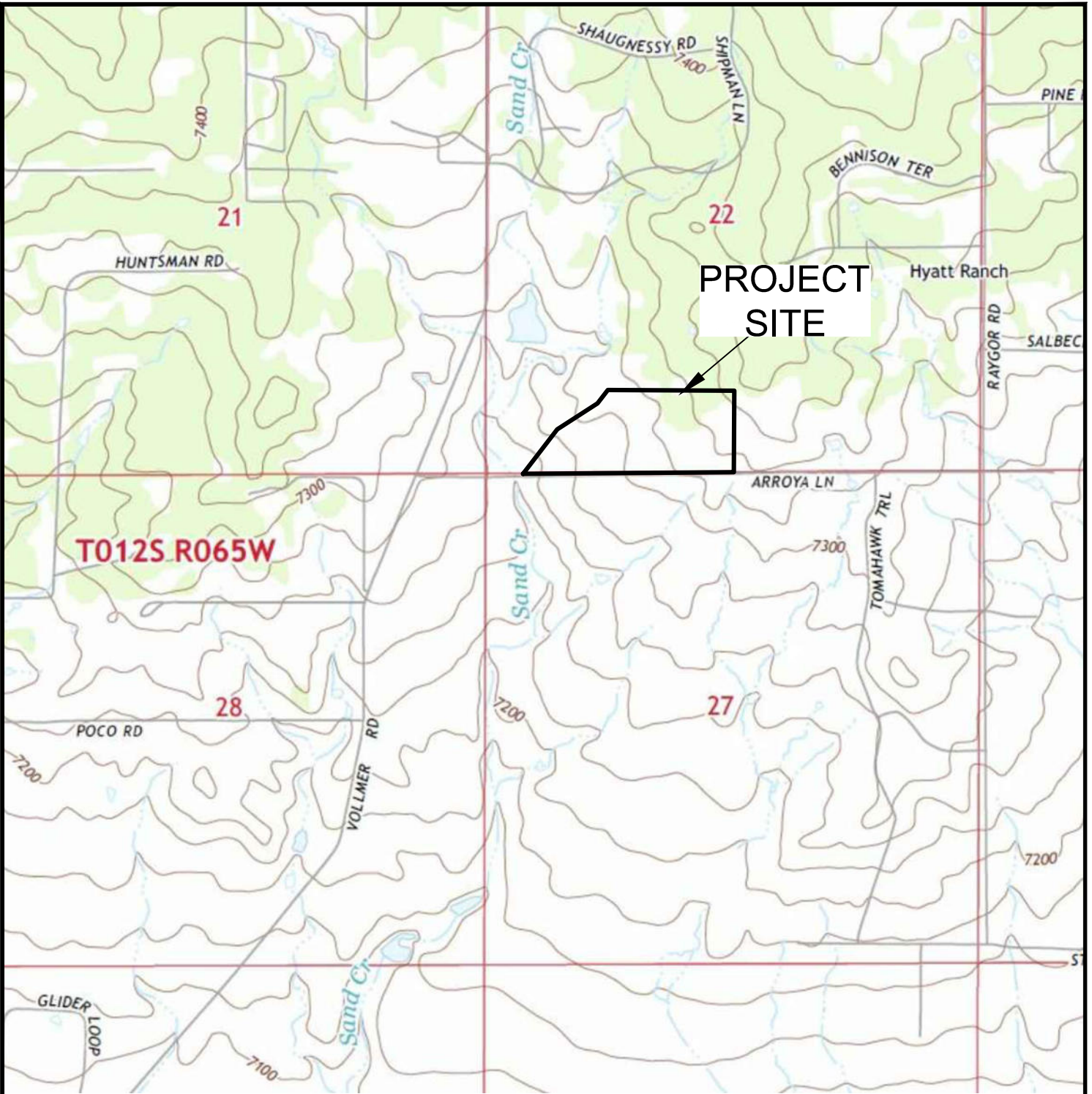

**PROJECT
SITE**

T012S R065W







USGS TOPOGRAPHY MAP

RETREAT AT TIMBERRIDGE FIL. NO. 4
EL PASO COUNTY, CO
TIMBERRIDGE DEVELOPMENT GROUP, LLC

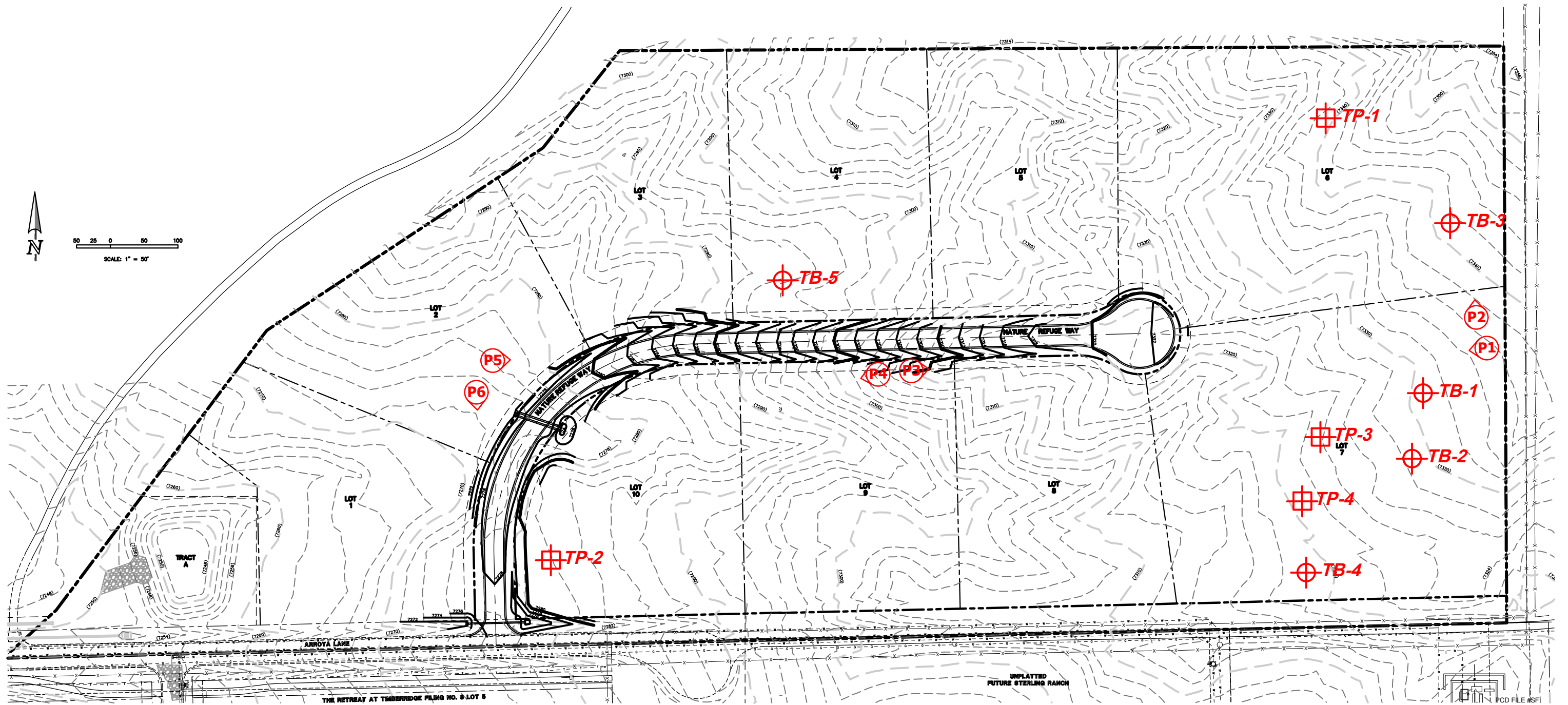
JOB NO.
231468

FIG. 2



-  TB- APPROXIMATE TEST BORING LOCATION AND NUMBER
-  TP- APPROXIMATE TEST PIT LOCATION AND NUMBER
-  - APPROXIMATE PHOTOGRAPH LOCATION AND NUMBER



EXPLORATION AND SITE PLAN

RETREAT AT TIMBERRIDGE FIL. NO. 4
 EL PASO COUNTY, CO
 TIMBERRIDGE DEVELOPMENT GROUP, LLC

JOB NO.
231468

FIG. 3

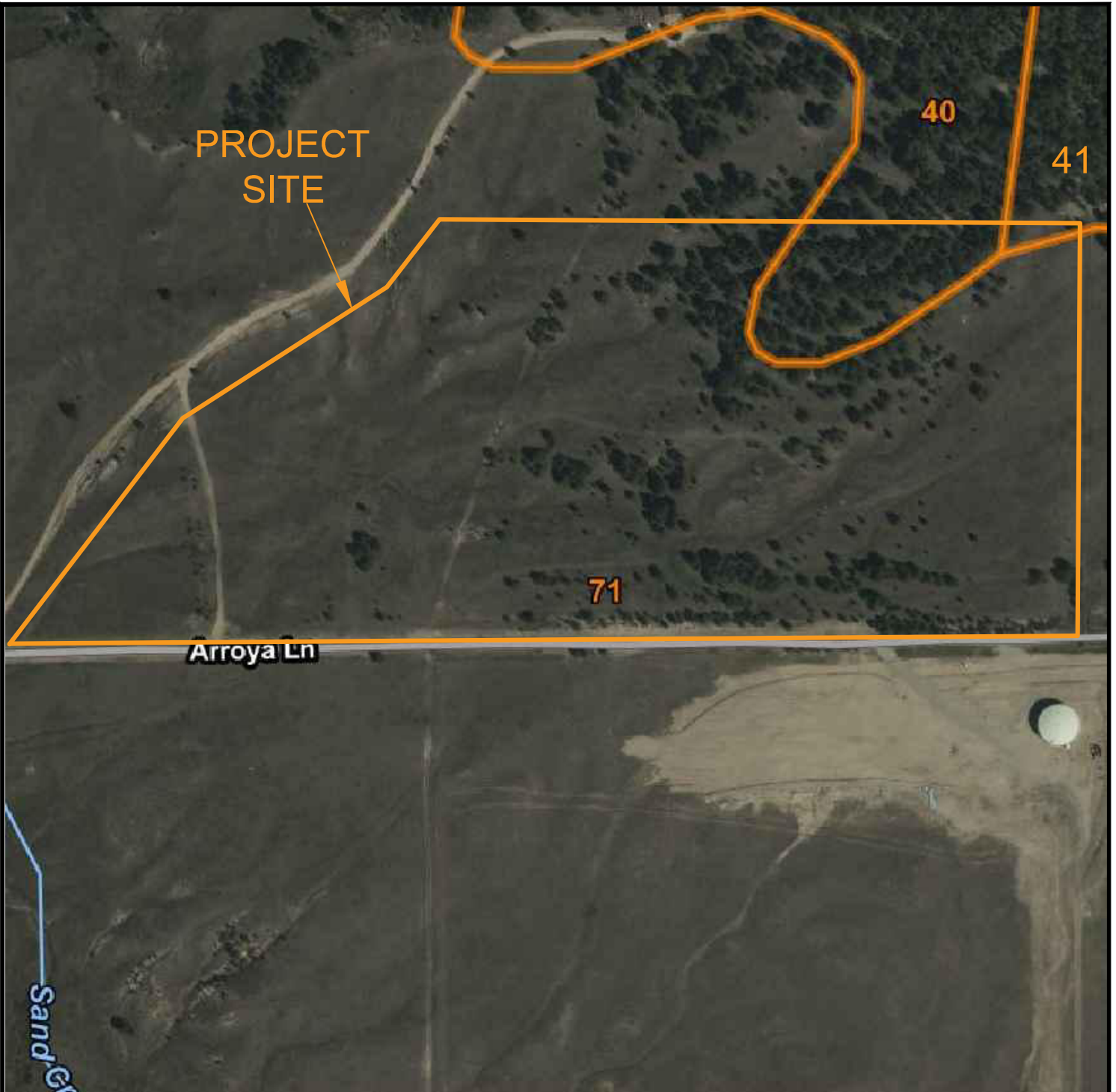

SOIL SURVEY MAP

RETREAT AT TIMBERRIDGE FIL. NO. 4
EL PASO COUNTY, CO
TIMBERRIDGE DEVELOPMENT GROUP, LLC

JOB NO.
231648

FIG. 4

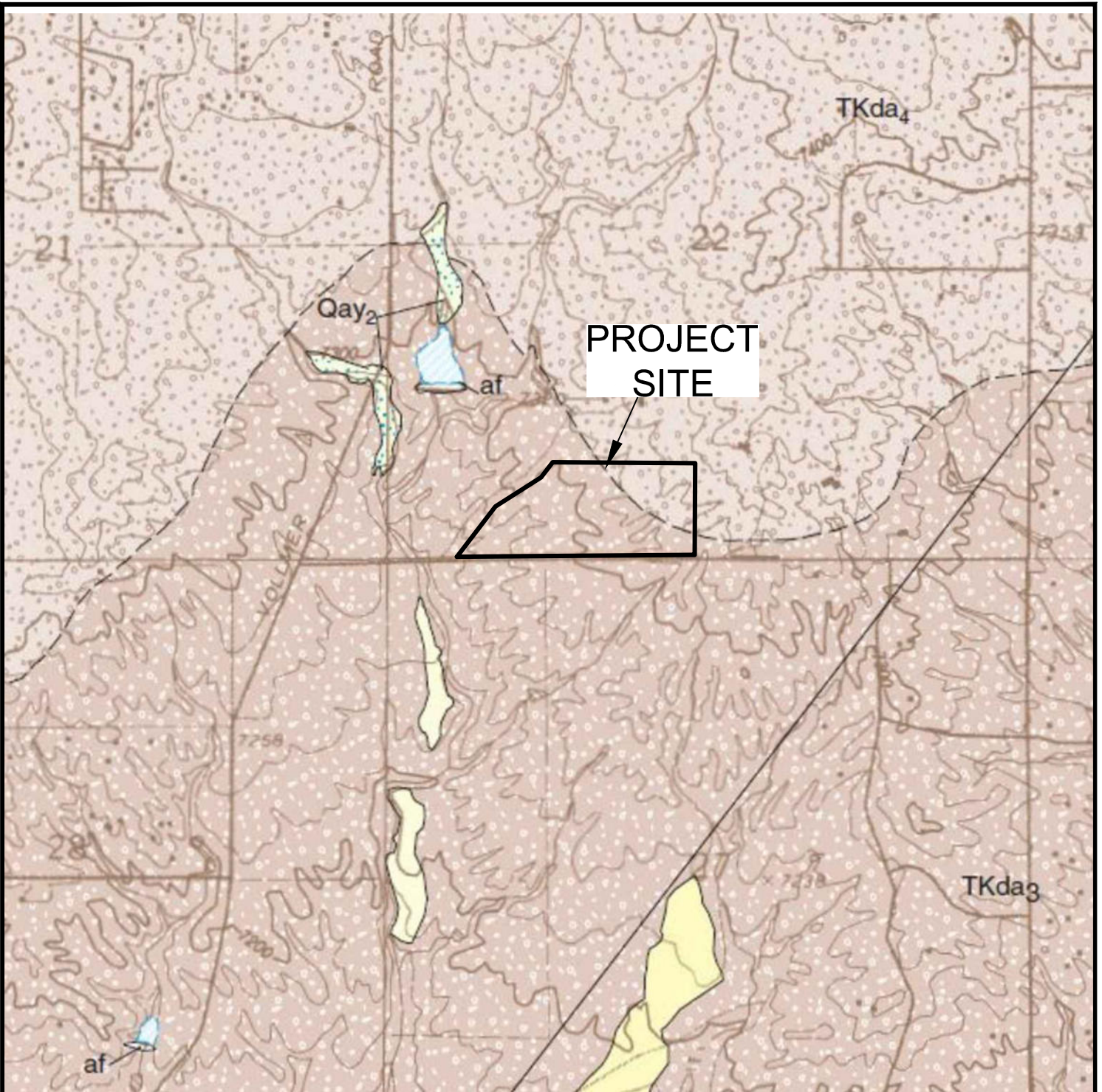

**GEOLOGIC MAP OF THE
FALCON NW QUADRANGLE**
RETREAT AT TIMBERRIDGE FIL. NO. 4
EL PASO COUNTY, CO
TIMBERRIDGE DEVELOPMENT GROUP, LLC

JOB NO.
231468

FIG. 5

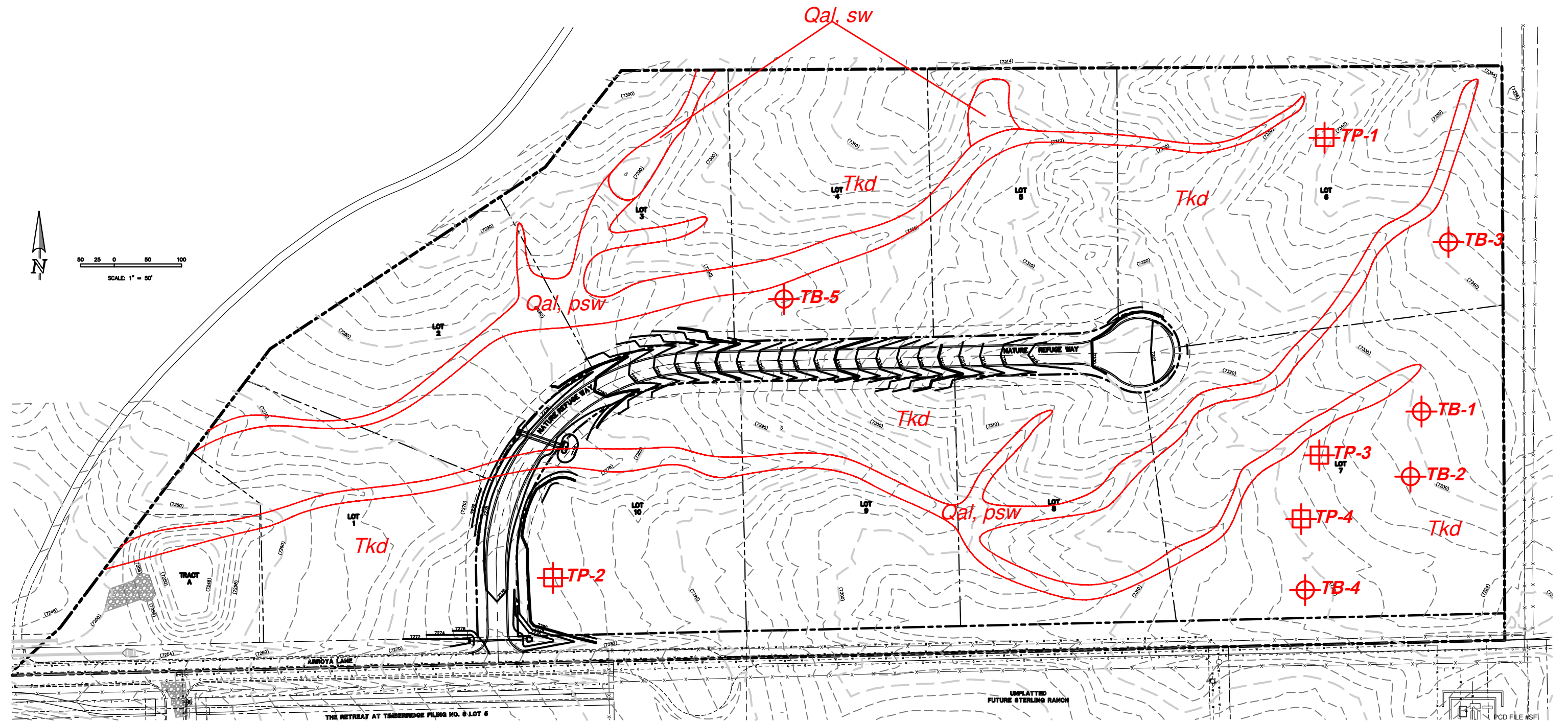

Legend:

- Qal - Recent Alluvium of Holocene Age:
recent water deposited materials
- Tkd - Dawson Formation of Tertiary to Cretaceous Age:
arkosic sandstone with interbedded claystone and siltstone
- psw - potential seasonally shallow groundwater area
- sw - seasonally shallow groundwater area



GEOLOGY / ENGINEERING MAP

RETREAT AT TIMBERRIDGE FIL. NO. 4
EL PASO COUNTY, CO
TIMBERRIDGE DEVELOPMENT GROUP, LLC

JOB NO.
231468

FIG. 6

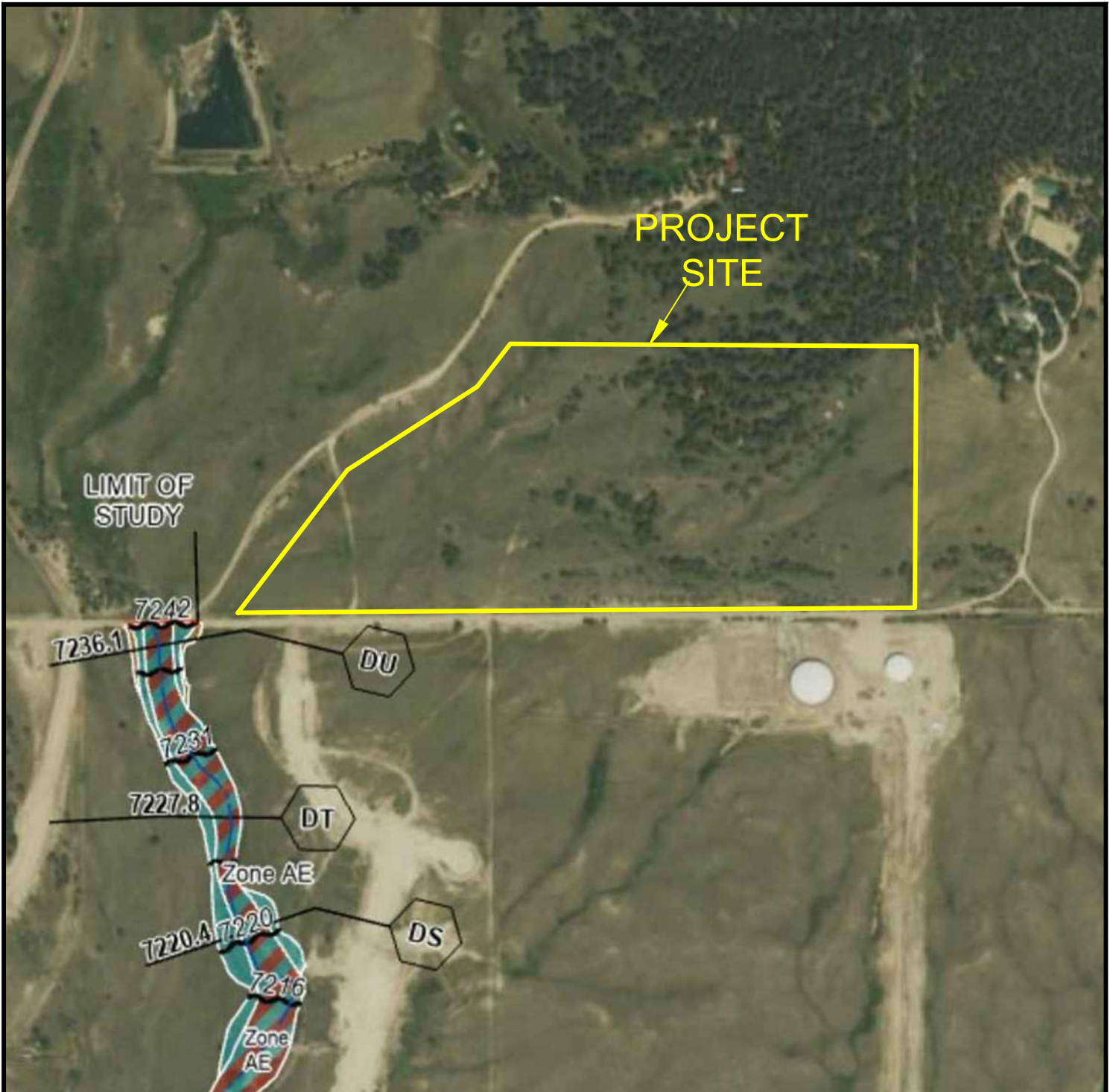

FEMA FLOODPLAIN MAP
 RETREAT AT TIMBERRIDGE FIL. NO. 4
 EL PASO COUNTY, CO
 TIMBERRIDGE DEVELOPMENT GROUP, LLC

JOB NO.
 231468

FIG. 7

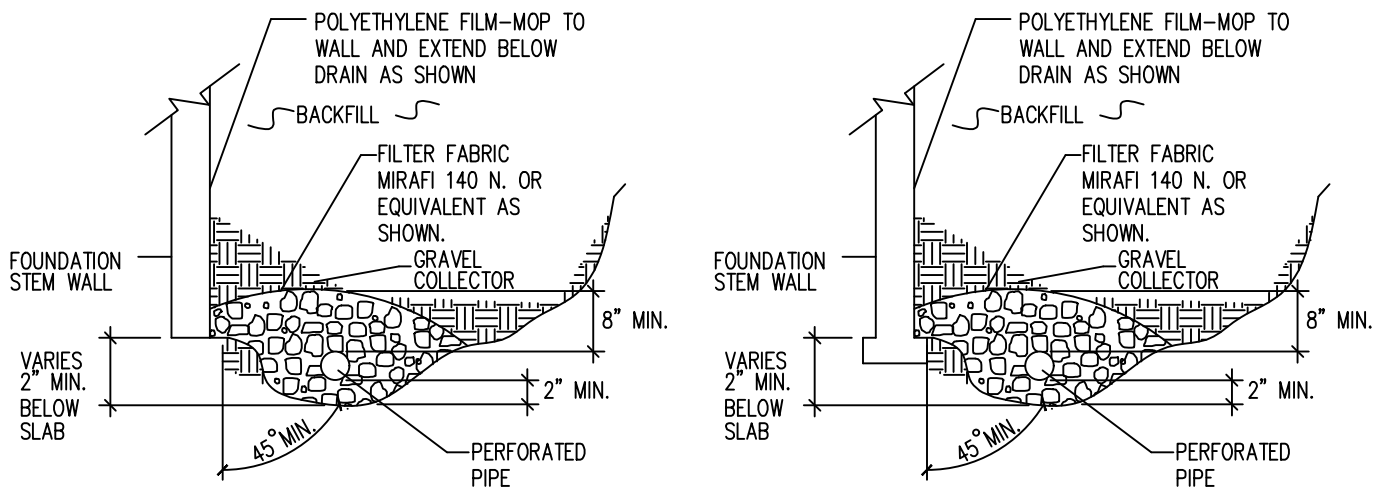

NOTES:

-GRAVEL SIZE IS RELATED TO DIAMETER OF PIPE PERFORATIONS-85% GRAVEL GREATER THAN 2x PERFORATION DIAMETER.

-PIPE DIAMETER DEPENDS UPON EXPECTED SEEPAGE. 4-INCH DIAMETER IS MOST OFTEN USED.

-ALL PIPE SHALL BE PERFORATED PLASTIC. THE DISCHARGE PORTION OF THE PIPE SHOULD BE NON-PERFORATED PIPE.

-FLEXIBLE PIPE MAY BE USED UP TO 8 FEET IN DEPTH, IF SUCH PIPE IS DESIGNED TO WITHSTAND THE PRESSURES. RIGID PLASTIC PIPE WOULD OTHERWISE BE REQUIRED.

-MINIMUM GRADE FOR DRAIN PIPE TO BE 1% OR 3 INCHES OF FALL IN 25 FEET.

-DRAIN TO BE PROVIDED WITH A FREE GRAVITY OUTFALL, IF POSSIBLE. A SUMP AND PUMP MAY BE USED IF GRAVITY OUTFALL IS NOT AVAILABLE.



PERIMETER DRAIN DETAIL

RETREAT AT TIMBERRIDGE FIL. NO. 4
EL PASO COUNTY, CO
TIMBERRIDGE DEVELOPMENT GROUP, LLC

JOB NO.
231468

FIG. 8

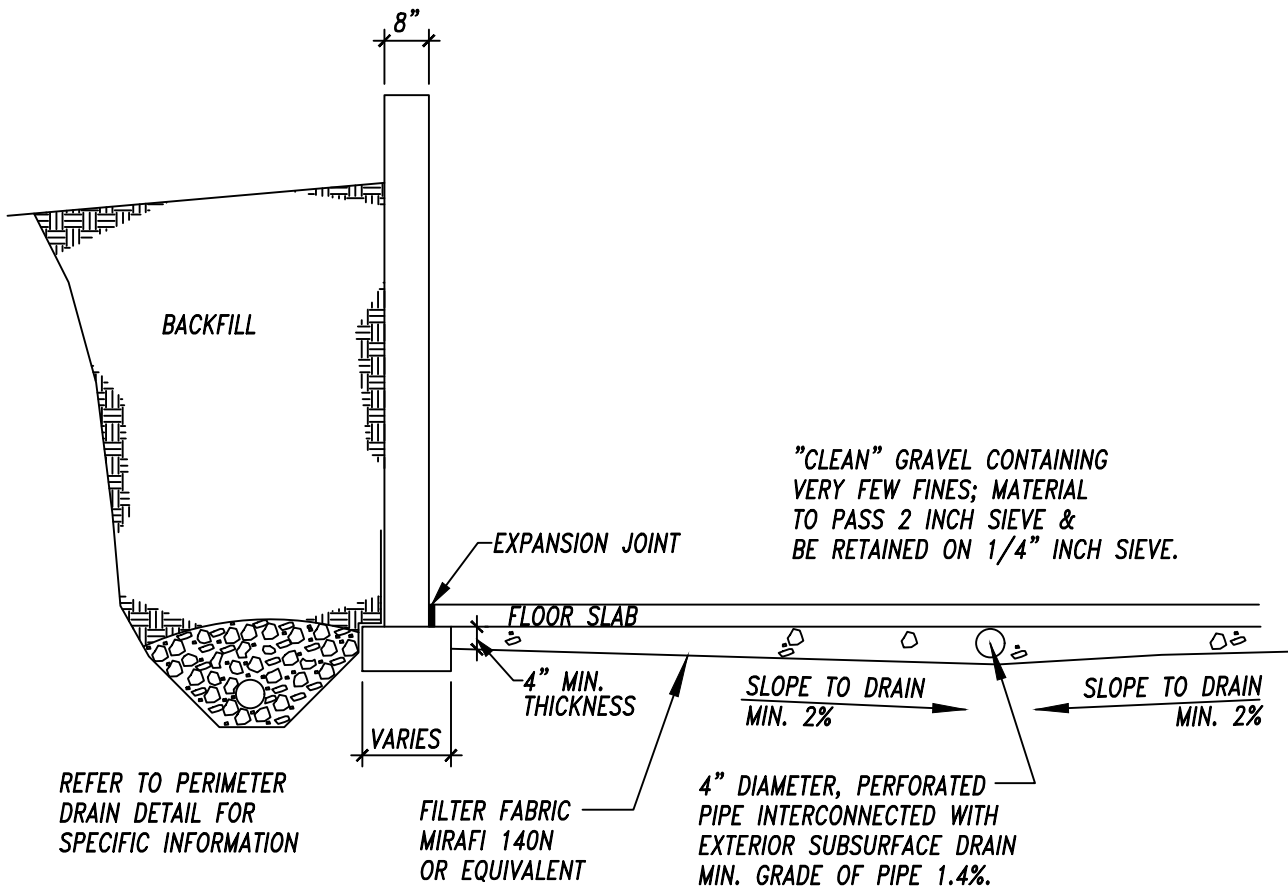

**TYP. UNDERSLAB DRAINAGE LAYER
(CAPILLARY BREAK)**
 RETREAT AT TIMBERRIDGE FIL. NO. 4
 EL PASO COUNTY, CO
 TIMBERRIDGE DEVELOPMENT GROUP, LLC

JOB NO.
231468

FIG. 9

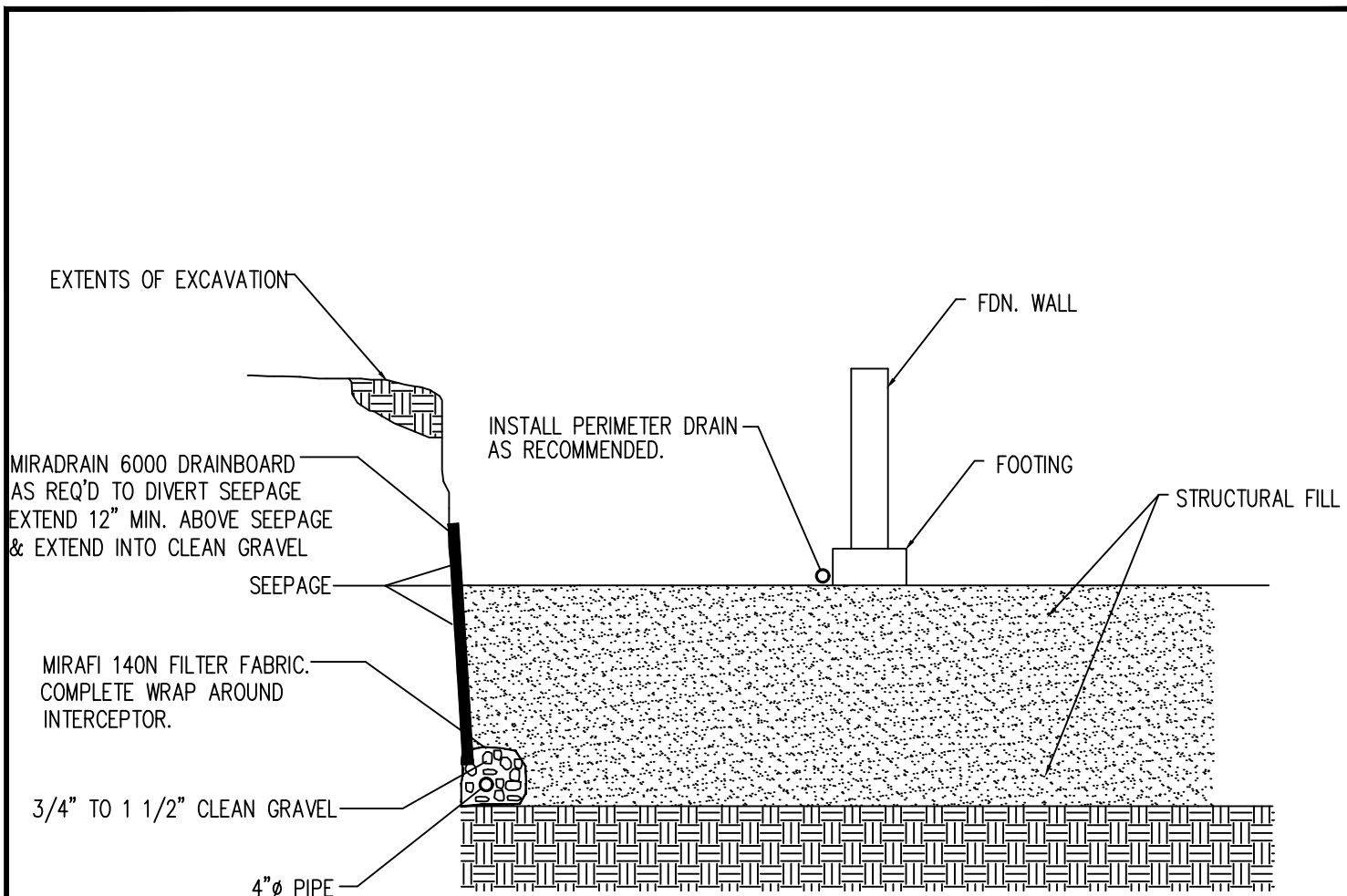

NOTE:
EXTEND INTERCEPTOR DRAIN TO UNDERDRAIN OR TO SUMP.
BENCH DRAIN INTO NATIVE SOILS 12 INCHES MINIMUM.

INTERCEPTOR DRAIN DETAIL

N.T.S.



INTERCEPTOR DRAIN DETAIL

RETREAT AT TIMBERRIDGE FIL. NO. 4
EL PASO COUNTY, CO
TIMBERRIDGE DEVELOPMENT GROUP, LLC

JOB NO.
231468

FIG. 10

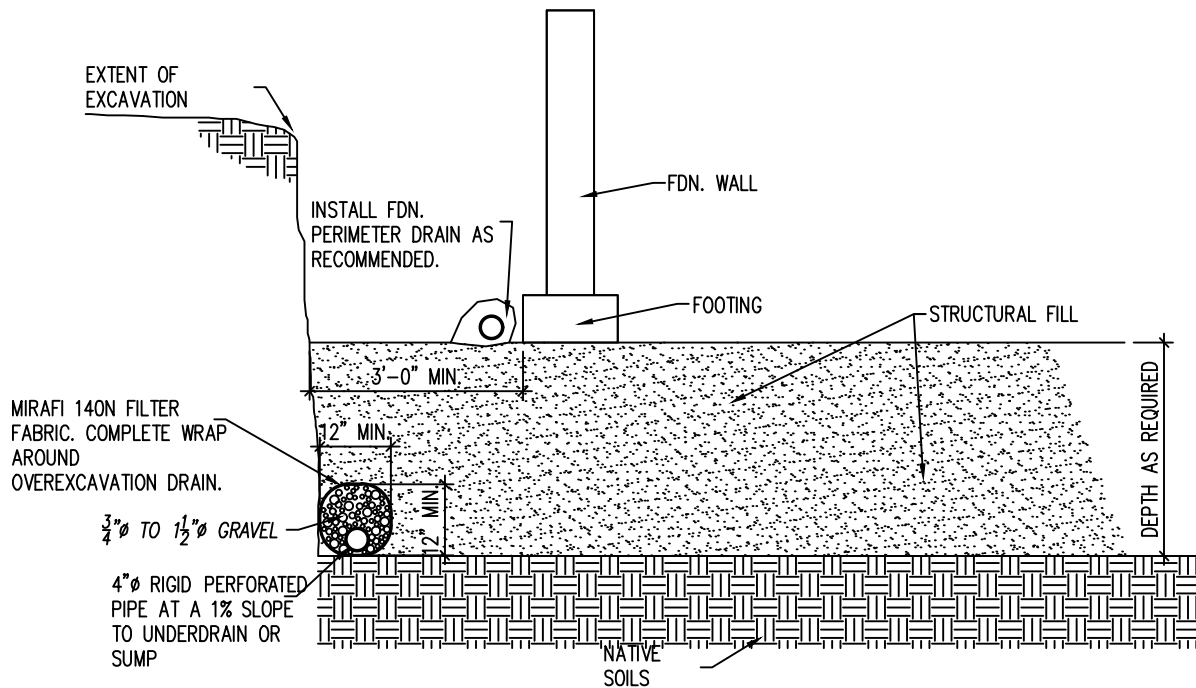

OVEREXCAVATION DRAIN DETAIL

N.T.S.

NOTE:

EXTEND DRAIN TO SUMP AS REQ'D.



OVEREXCAVATION DRAIN

RETREAT AT TIMBERRIDGE FIL. NO. 4
EL PASO COUNTY, CO
TIMBERRIDGE DEVELOPMENT GROUP, LLC

JOB NO.
231468

11

APPENDIX A: Site Photographs

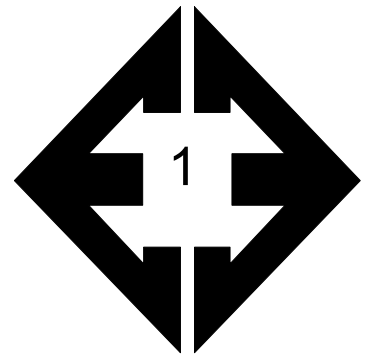

Looking west from the eastern side of the site.

September 13, 2023

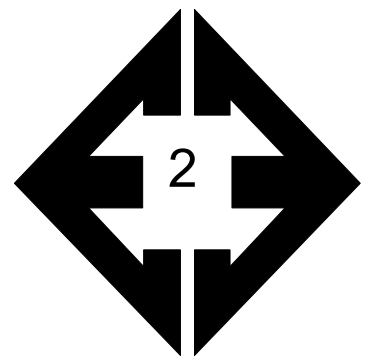

Looking north from the eastern side of the site.

September 13, 2023

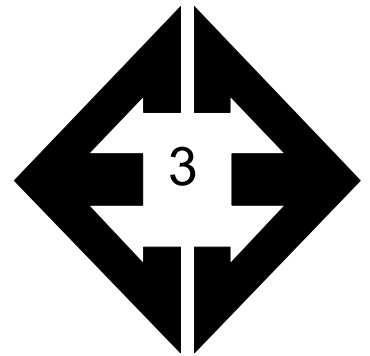

Looking east towards erosion feature eastern side of site.

September 13, 2023

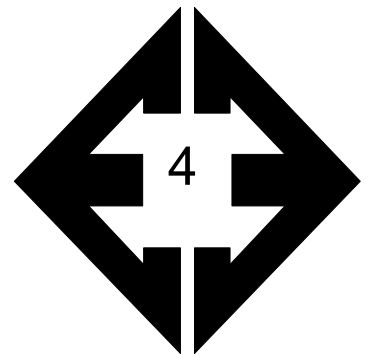

Looking west from the central portion of the site.

September 13, 2023

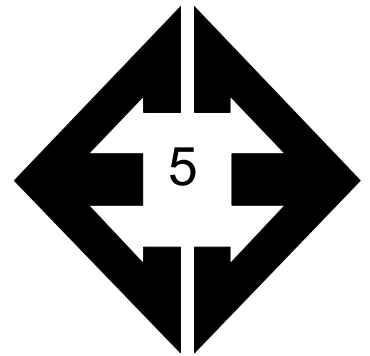

**Looking east from the
northwestern portion
of the site.**

September 13, 2023

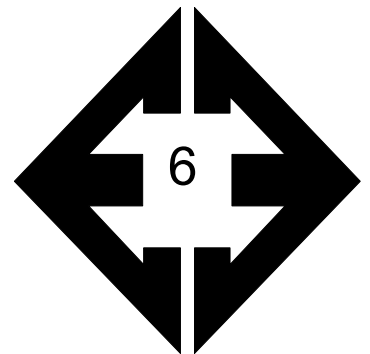

**Looking south from
the northwestern
portion of the site.**

September 13, 2023



APPENDIX B: Test Boring and Test Pit Logs

TABLE B-1
DEPTH TO BEDROCK

TEST BORING	DEPTH TO BEDROCK (ft.)
1	4
2	4
3	9
4	3
5	14

TEST BORING 1
 DATE DRILLED 6/4/2019

TEST BORING 2
 DATE DRILLED 6/4/2019

REMARKS

REMARKS

DRY TO 19', 6/5/19

DRY TO 14.5', 6/5/19

SAND, SILTY, BROWN, MEDIUM
 DENSE, MOIST

SAND, SILTY, BROWN, MEDIUM
 DENSE, MOIST

SANDSTONE, WEAK, BROWN,
 WEATHERED (SAND, SILTY, VERY
 DENSE, MOIST)

SANDSTONE, WEAK, GRAY,
 WEATHERED (SAND, CLAYEY,
 VERY DENSE, MOIST)

Depth (ft)	Symbol	Samples	Blows per foot	Watercontent %	Soil Type	Depth (ft)	Symbol	Samples	Blows per foot	Watercontent %	Soil Type
			28	6.1	1				27	5.7	1
5			50 9"	6.2	2	5			50 11"	7.4	2
10			50 7"	9.5	2	10			50 8"	9.5	2
15			50 5"	8.1	2	15			50 6"	8.2	2
20			50 6"	9.3	2	20					



TEST BORING LOGS
 RETREAT AT TIMBERRIDER, F-4
 TIMBERRIDGE DEVELOPMENT

JOB NO.
 231468

FIG. B-1

TEST BORING 3
 DATE DRILLED 6/4/2019

TEST BORING 4
 DATE DRILLED 2/16/2017

REMARKS

REMARKS

DRY TO 19', 6/5/19

DRY TO 14.5',
 2/17/17

SAND, SILTY, TAN, LOOSE to
 MEDIUM DENSE, MOIST

SAND, CLAYEY, GREEN-GRAY,
 DENSE, MOIST

SANDSTONE, WEAK, GRAY,
 WEATHERED (SAND, SILTY, VERY
 DENSE, MOIST)

SANDSTONE, WEAK, GREEN-
 GRAY, WEATHERED (SAND,
 CLAYEY, VERY DENSE, MOIST)

Depth (ft)	Symbol	Samples	Blows per foot	Watercontent %	Soil Type	Depth (ft)	Symbol	Samples	Blows per foot	Watercontent %	Soil Type
5			8	5.3	1	5			30	13.0	1
5			23	7.2	1	5			50 11"	13.1	2
10			50 6"	10.3	2	10			50 7"	13.4	2
15			50 6"	9.8	2	15			50 7"	9.2	2
20			50 5"	8.4	2	20					



TEST BORING LOGS
 RETREAT AT TIMBERRIDER, F-4
 TIMBERRIDGE DEVELOPMENT

JOB NO.
 231468

FIG. B-2

TEST BORING 5
 DATE DRILLED 2/16/2017

REMARKS

DRY TO 14', 2/17/17

SAND, WITH SILT, TAN, MEDIUM
 DENSE to LOOSE, DRY to MOIST

SANDSTONE, WEAK, TAN,
 WEATHERED (SAND, CLAYEY,
 VERY DENSE, MOIST)

Depth (ft)	Symbol	Samples	Blows per foot	Watercontent %	Soil Type
5	(Dotted pattern)		19	2.3	1
5	(Dotted pattern)		7	7.4	1
10	(Dotted pattern)		6	5.5	1
15	(Dotted pattern)		50	12.5	2
20	(Dotted pattern)				



TEST BORING LOGS

RETREAT AT TIMBERRIDER, F-4
 TIMBERRIDGE DEVELOPMENT

JOB NO.
 231468

FIG. B-3

TEST PIT 1
 DATE EXCAVATED 2/15/2017
 REMARKS

TEST PIT 2
 DATE EXCAVATED 2/15/2017
 REMARKS

REMARKS	Depth (ft)	Symbol	Samples	Soil Structure Shape	Soil Structure Grade	Soil Type	REMARKS	Depth (ft)	Symbol	Samples	Soil Structure Shape	Soil Structure Grade	Soil Type
topsoil, sandy loam, brown	1	*		gr	w	2A	topsoil, sandy loam, brown	1	*		gr	w	2A
weathered to formational silty sandstone, fine to coarse grained, reddish-tan	2			ma		4A	gravelly loamy sand, fine to coarse grained, tan	2			sg		1
	3						weathered silty sandstone, fine to coarse grained, reddish-tan	3					
4						4					ma		4A
	5						sandy claystone, olive-gray	5					
	6							6			ma		4A
	7						* - signs of seasonally occurring groundwater	7					
	8							8					
	9							9					
	10							10					

Soil Structure Shape

- granular - gr
- platy - pl
- blocky - bl
- prismatic - pr
- single grain - sg
- massive - ma

Soil Structure Grade

- weak - w
- moderate - m
- strong - s
- loose - l



TEST PIT LOGS

RETREAT AT TIMBERRIDGE, F-4
 TIMBERRIDGE DEVELOPMENT

JOB NO.
 231468

FIG. B-4

TEST PIT 3
DATE EXCAVATED 4/13/2019

TEST PIT 4
DATE EXCAVATED 4/13/2019

REMARKS

REMARKS

REMARKS	Depth (ft)	Symbol	Samples	Soil Structure Shape	Soil Structure Grade	Soil Type	REMARKS	Depth (ft)	Symbol	Samples	Soil Structure Shape	Soil Structure Grade	Soil Type
topsoil sandy clay loam, brown	1						topsoil sandy clay, brown	1					
	2						very sandy clay, light brown	2			gr	w	4A
gravelly sandy clay loam, fine to coarse grained, light brown	3			gr	m	3		3					
	4			ma		4A		4			ma		4A
silty sandstone, fine to coarse grained, poorly cemented, reddish-brown	5						silty sandstone, fine to coarse grained, poorly cemented, light brown	5					
	6						sandy claystone, olive gray	6			pl		5
	7							7					
	8							8					
	9							9					
	10							10					

Soil Structure Shape

granular - gr
platy - pl
blocky - bl
prismatic - pr
single grain - sg
massive - ma

Soil Structure Grade

weak - w
moderate - m
strong - s
loose - l



TEST PIT LOGS

RETREAT AT TIMBERRIDGE, F-4
TIMBERRIDGE DEVELOPMENT

JOB NO.
231468

FIG. B-5



APPENDIX C: Laboratory Test Results

**TABLE C-1
SUMMARY OF LABORATORY TEST RESULTS**

SOIL TYPE	TEST BORING NO.	DEPTH (FT)	PASSING NO. 200 SIEVE (%)	LIQUID LIMIT	PLASTIC LIMIT	PLASTIC INDEX	SULFATE (WT %)	USCS	SOIL DESCRIPTION
1	1	2-3	15.4	20	17	3		SM	SAND, SILTY
1	3	5	15.3				<0.01	SM	SAND, SILTY
1	4	2-3	34.3					SC	SAND, CLAYEY
1	4	5	47.6					SC	SAND, CLAYEY
1	5	2-3	11.2					SW-SM	SAND, WITH SILT
2	2	5	17.1	26	17	9		SC	SANDSTONE (SAND, CLAYEY)
2	3	10	12.1				<0.01	SM	SANDSTONE (SAND, SILTY)

TEST BORING 1
 DEPTH (FT) 2-3

SOIL DESCRIPTION SAND, SILTY
 SOIL TYPE 1

**Sieve Analysis
 Grain Size Distribution**

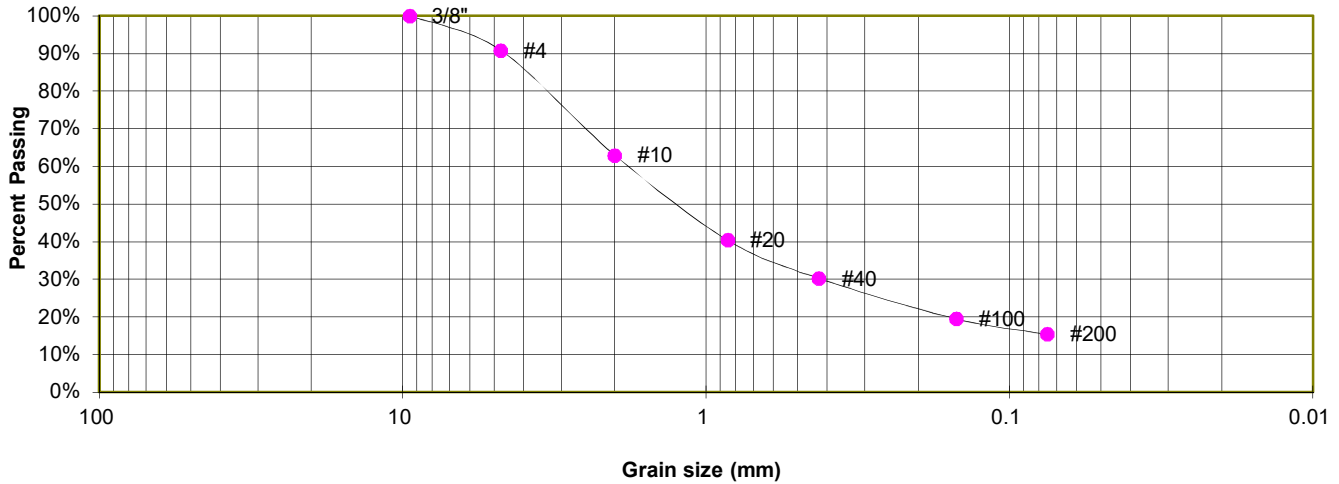

GRAIN SIZE ANALYSIS

U.S. Sieve #	Percent Finer
3"	
1 1/2"	
3/4"	
1/2"	
3/8"	100.0%
4	90.8%
10	63.0%
20	40.4%
40	30.3%
100	19.5%
200	15.4%

ATTERBERG LIMITS

Plastic Limit	17
Liquid Limit	20
Plastic Index	3

SOIL CLASSIFICATION

USCS CLASSIFICATION: SM



LABORATORY TEST RESULTS

RETREAT AT TIMBERRIDER, F-4
 TIMBERRIDGE DEVELOPMENT

JOB NO.
 231468

FIG. C-1

TEST BORING 3
 DEPTH (FT) 5

SOIL DESCRIPTION SAND, SILTY
 SOIL TYPE 1

**Sieve Analysis
 Grain Size Distribution**

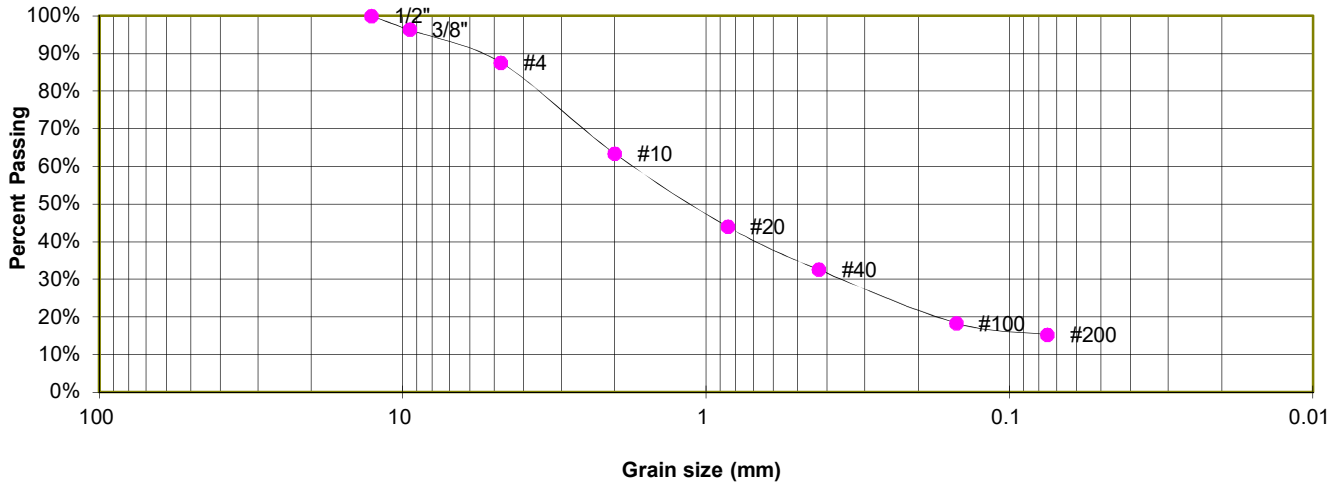

GRAIN SIZE ANALYSIS

U.S. Sieve #	Percent Finer
3"	
1 1/2"	
3/4"	
1/2"	100.0%
3/8"	96.3%
4	87.6%
10	63.4%
20	44.0%
40	32.6%
100	18.4%
200	15.3%

SOIL CLASSIFICATION

USCS CLASSIFICATION: SM



LABORATORY TEST RESULTS

RETREAT AT TIMBERRIDER, F-4
 TIMBERRIDGE DEVELOPMENT

JOB NO.
 231468

FIG. C-2

TEST BORING 4
 DEPTH (FT) 2-3

SOIL DESCRIPTION SAND, CLAYEY
 SOIL TYPE 1

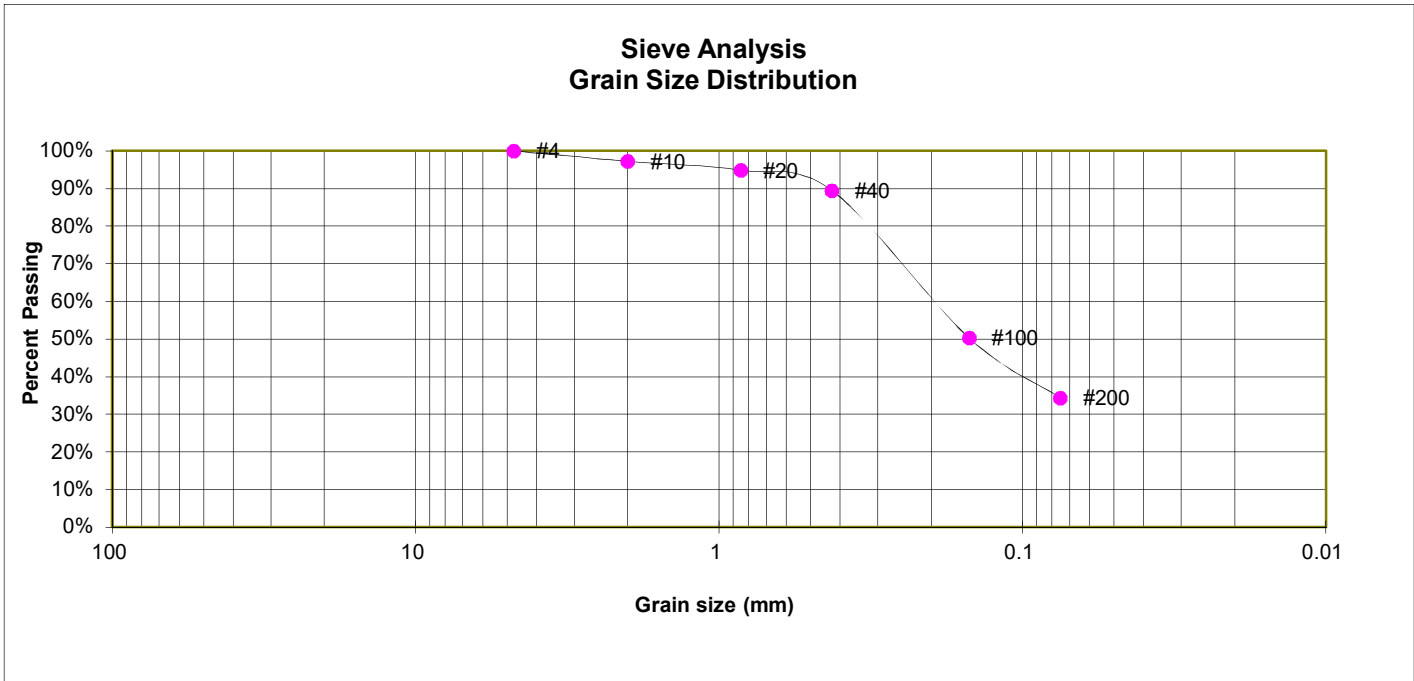

GRAIN SIZE ANALYSIS

U.S. Sieve #	Percent Finer
3"	
1 1/2"	
3/4"	
1/2"	
3/8"	
4	100.0%
10	97.2%
20	94.9%
40	89.5%
100	50.3%
200	34.3%

SOIL CLASSIFICATION

USCS CLASSIFICATION: SC



LABORATORY TEST RESULTS

RETREAT AT TIMBERRIDER, F-4
 TIMBERRIDGE DEVELOPMENT

JOB NO.
 231468

FIG. C-3

TEST BORING 4
DEPTH (FT) 5

SOIL DESCRIPTION SAND, CLAYEY
SOIL TYPE 1

**Sieve Analysis
Grain Size Distribution**

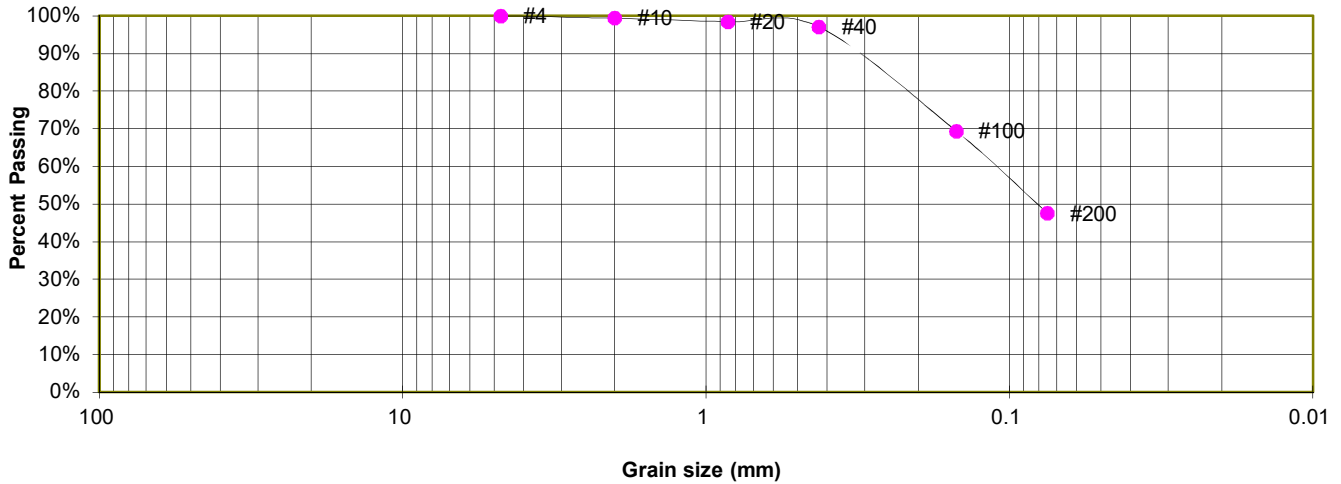

GRAIN SIZE ANALYSIS

U.S. Sieve #	Percent Finer
3"	
1 1/2"	
3/4"	
1/2"	
3/8"	
4	100.0%
10	99.4%
20	98.4%
40	97.1%
100	69.4%
200	47.6%

SOIL CLASSIFICATION

USCS CLASSIFICATION: SC



LABORATORY TEST RESULTS

RETREAT AT TIMBERRIDER, F-4
TIMBERRIDGE DEVELOPMENT

JOB NO.
231468

FIG. C-4

TEST BORING 5
DEPTH (FT) 2-3

SOIL DESCRIPTION SAND, WITH SILT
SOIL TYPE 1

Sieve Analysis Grain Size Distribution

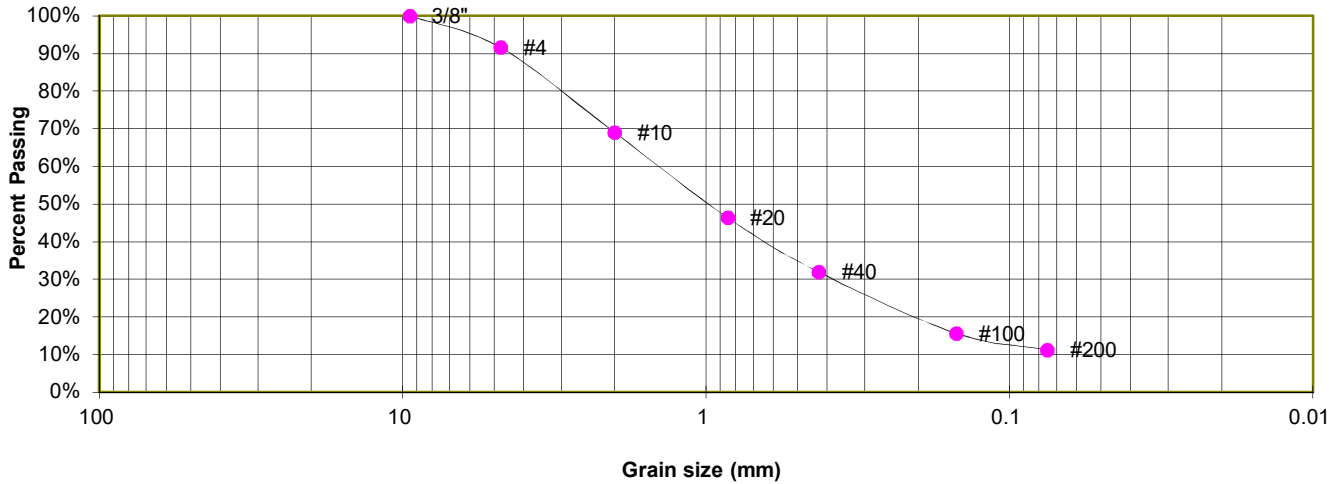

GRAIN SIZE ANALYSIS

U.S. Sieve #	Percent Finer
3"	
1 1/2"	
3/4"	
1/2"	
3/8"	100.0%
4	91.6%
10	69.0%
20	46.4%
40	31.9%
100	15.7%
200	11.2%

SOIL CLASSIFICATION

USCS CLASSIFICATION: SW-SM



LABORATORY TEST RESULTS

RETREAT AT TIMBERRIDER, F-4
TIMBERRIDGE DEVELOPMENT

JOB NO.
231468

FIG. C-5

TEST BORING 2
 DEPTH (FT) 5

SOIL DESCRIPTION SANDSTONE (SAND, CLAYEY)
 SOIL TYPE 2

**Sieve Analysis
 Grain Size Distribution**

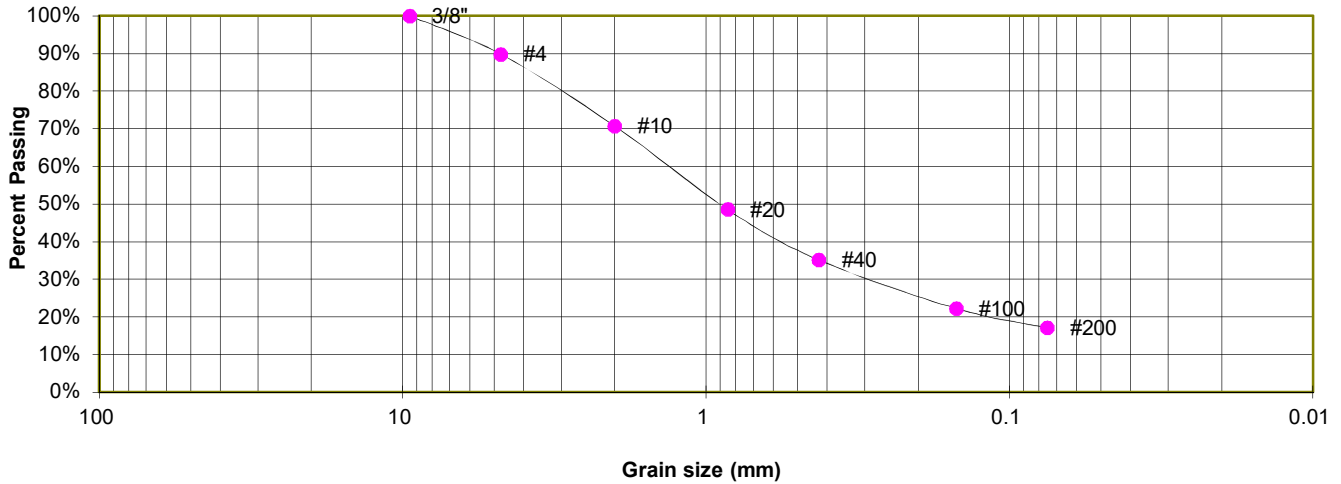

GRAIN SIZE ANALYSIS

U.S. Sieve #	Percent Finer
3"	
1 1/2"	
3/4"	
1/2"	
3/8"	100.0%
4	89.9%
10	70.7%
20	48.6%
40	35.1%
100	22.3%
200	17.1%

ATTERBERG LIMITS

Plastic Limit	17
Liquid Limit	26
Plastic Index	9

SOIL CLASSIFICATION

USCS CLASSIFICATION: SC



LABORATORY TEST RESULTS

RETREAT AT TIMBERRIDER, F-4
 TIMBERRIDGE DEVELOPMENT

JOB NO.
 231468

FIG. C-6

TEST BORING 3
 DEPTH (FT) 10

SOIL DESCRIPTION SANDSTONE (SAND, SILTY)
 SOIL TYPE 2

**Sieve Analysis
 Grain Size Distribution**

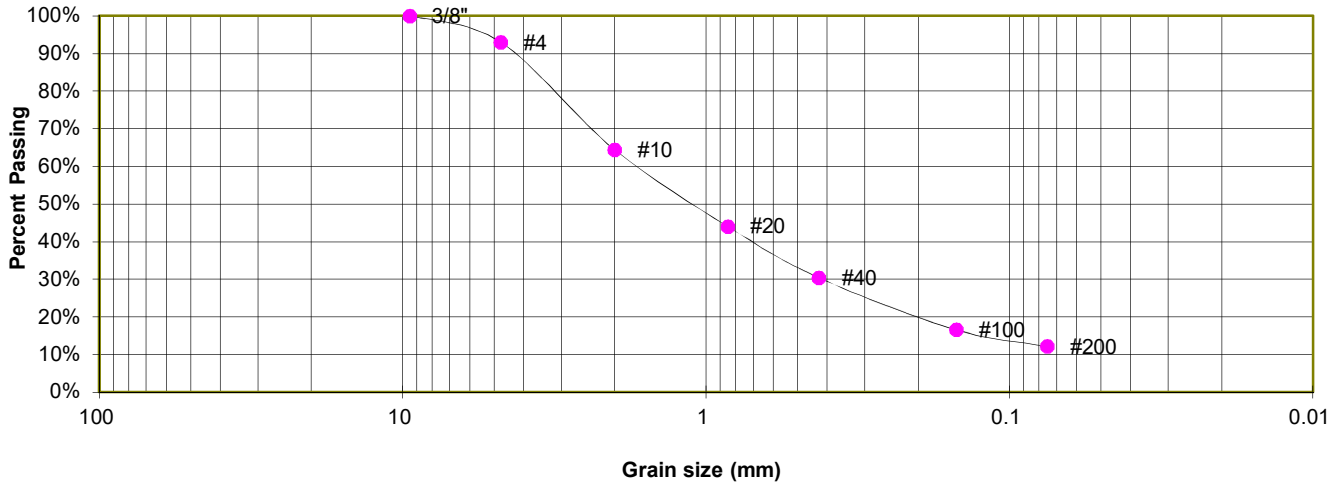

GRAIN SIZE ANALYSIS

U.S. Sieve #	Percent Finer
3"	
1 1/2"	
3/4"	
1/2"	
3/8"	100.0%
4	93.0%
10	64.4%
20	44.1%
40	30.4%
100	16.6%
200	12.1%

SOIL CLASSIFICATION

USCS CLASSIFICATION: SM



LABORATORY TEST RESULTS

RETREAT AT TIMBERRIDER, F-4
 TIMBERRIDGE DEVELOPMENT

JOB NO.
 231468

FIG. C-7

APPENDIX D: USDA Soil Survey Descriptions

El Paso County Area, Colorado

40—Kettle gravelly loamy sand, 3 to 8 percent slopes

Map Unit Setting

National map unit symbol: 368g

Elevation: 7,000 to 7,700 feet

Farmland classification: Not prime farmland

Map Unit Composition

Kettle and similar soils: 85 percent

Estimates are based on observations, descriptions, and transects of the mapunit.

Description of Kettle

Setting

Landform: Hills

Landform position (three-dimensional): Side slope

Down-slope shape: Linear

Across-slope shape: Linear

Parent material: Sandy alluvium derived from arkose

Typical profile

E - 0 to 16 inches: gravelly loamy sand

Bt - 16 to 40 inches: gravelly sandy loam

C - 40 to 60 inches: extremely gravelly loamy sand

Properties and qualities

Slope: 3 to 8 percent

Depth to restrictive feature: More than 80 inches

Drainage class: Somewhat excessively drained

Runoff class: Low

Capacity of the most limiting layer to transmit water (Ksat): High
(2.00 to 6.00 in/hr)

Depth to water table: More than 80 inches

Frequency of flooding: None

Frequency of ponding: None

Available water supply, 0 to 60 inches: Low (about 3.4 inches)

Interpretive groups

Land capability classification (irrigated): None specified

Land capability classification (nonirrigated): 4e

Hydrologic Soil Group: B

Ecological site: F048AY908CO - Mixed Conifer

Hydric soil rating: No

Minor Components

Other soils

Percent of map unit:

Hydric soil rating: No

Pleasant

Percent of map unit:

Landform: Depressions

Hydric soil rating: Yes

Data Source Information

Soil Survey Area: El Paso County Area, Colorado

Survey Area Data: Version 21, Aug 24, 2023

El Paso County Area, Colorado

41—Kettle gravelly loamy sand, 8 to 40 percent slopes

Map Unit Setting

National map unit symbol: 368h

Elevation: 7,000 to 7,700 feet

Farmland classification: Not prime farmland

Map Unit Composition

Kettle and similar soils: 85 percent

Estimates are based on observations, descriptions, and transects of the mapunit.

Description of Kettle

Setting

Landform: Hills

Landform position (three-dimensional): Side slope

Down-slope shape: Linear

Across-slope shape: Linear

Parent material: Sandy alluvium derived from arkose

Typical profile

E - 0 to 16 inches: gravelly loamy sand

Bt - 16 to 40 inches: gravelly sandy loam

C - 40 to 60 inches: extremely gravelly loamy sand

Properties and qualities

Slope: 8 to 40 percent

Depth to restrictive feature: More than 80 inches

Drainage class: Somewhat excessively drained

Runoff class: Medium

Capacity of the most limiting layer to transmit water (Ksat): High
(2.00 to 6.00 in/hr)

Depth to water table: More than 80 inches

Frequency of flooding: None

Frequency of ponding: None

Available water supply, 0 to 60 inches: Low (about 3.4 inches)

Interpretive groups

Land capability classification (irrigated): None specified

Land capability classification (nonirrigated): 7e

Hydrologic Soil Group: B

Ecological site: F048AY908CO - Mixed Conifer

Hydric soil rating: No

Minor Components

Other soils

Percent of map unit:

Hydric soil rating: No

Pleasant

Percent of map unit:

Landform: Depressions

Hydric soil rating: Yes

Data Source Information

Soil Survey Area: El Paso County Area, Colorado

Survey Area Data: Version 21, Aug 24, 2023

El Paso County Area, Colorado

71—Pring coarse sandy loam, 3 to 8 percent slopes

Map Unit Setting

National map unit symbol: 369k

Elevation: 6,800 to 7,600 feet

Farmland classification: Not prime farmland

Map Unit Composition

Pring and similar soils: 85 percent

Estimates are based on observations, descriptions, and transects of the mapunit.

Description of Pring

Setting

Landform: Hills

Landform position (three-dimensional): Side slope

Down-slope shape: Linear

Across-slope shape: Linear

Parent material: Arkosic alluvium derived from sedimentary rock

Typical profile

A - 0 to 14 inches: coarse sandy loam

C - 14 to 60 inches: gravelly sandy loam

Properties and qualities

Slope: 3 to 8 percent

Depth to restrictive feature: More than 80 inches

Drainage class: Well drained

Runoff class: Low

Capacity of the most limiting layer to transmit water (Ksat): High
(2.00 to 6.00 in/hr)

Depth to water table: More than 80 inches

Frequency of flooding: None

Frequency of ponding: None

Available water supply, 0 to 60 inches: Low (about 6.0 inches)

Interpretive groups

Land capability classification (irrigated): None specified

Land capability classification (nonirrigated): 3e

Hydrologic Soil Group: B

Ecological site: R048AY222CO - Loamy Park

Hydric soil rating: No

Minor Components

Pleasant

Percent of map unit:

Landform: Depressions

Hydric soil rating: Yes

Other soils

Percent of map unit:

Hydric soil rating: No

Data Source Information

Soil Survey Area: El Paso County Area, Colorado

Survey Area Data: Version 21, Aug 24, 2023