



Scott Meredith
Tri-State Generation and Transmission Association
1100 W. 116th Ave.
Denver, CO 80233

June 19, 2024

Scott,

This memo is to serve as an addendum to the original Vollmer Substation drainage report prepared by Terra Nova, dated January 31, 2022. This memo summarizes the design of a new extended detention basin to replace the existing sand filter and demonstrate compliance with El Paso County design requirements.

Watershed characteristics and rainfall depths, from the original drainage report were utilized and imported into The Mile High Flood District *Detention Basin Design Workbook* to calculate the water quality capture volume (WQCV) and required detention volumes for the proposed extended detention basin. The original spreadsheet utilized for the design of the sand filter is included as Exhibit 1 and the updated spreadsheet for the detention basin is included as Exhibit 2. The spreadsheet was also utilized to design the outlet structure and corresponding orifice plate. It should be noted that the basin geometry does not meet the length to width recommended ratio as the existing driveway geometry prevents the basin from obtaining the desired length.

The detention basin and outlet structure have been sized to discharge at lower rates than the originally approved sand filter, while fully detaining the 100-year storm event. The attached MHFD workbook shows a 5-year discharge rate of 0 cfs., but this is only due to a rounding issue in the spreadsheet as the calculated value is 0.02 cfs. Detailed design of the pond modifications and new outlet structure are attached. The table below summarizes the originally approved discharge values along with the reduced discharge values that can be expected with the installation of the orifice plate.

Sand Filter Discharge		Proposed EDB Discharge	
5 Year	100 Year	5 Year	100 Year
1.5 cfs	4.2 cfs	0.02 cfs	0.8 cfs

Please don't hesitate to contact me if you have any questions.

Sincerely,

David W. Schieldt, P.E., CFM
President
Del-Mont Consultants, Inc.



Attachments:

- Exhibit 1 – Terra Nova MHFD Detention Workbook (1-31-2022)
- Exhibit 2 – Del-Mont Consultant MHFD Detention Workbook
- Exhibit 3 – Detention Basin Design Drawings

Clarify which pages are old and for reference only and have been superceded (ie: all of the Sand Filter related pages have been superceded by EDB pages).

Adding title pages to separate each Exhibit would also suffice since the Exhibits are described on the previous page.

DETENTION BASIN STAGE-STORAGE TABLE BUILDER

UD-Detention, Version 3.07 (February 2017)

Project: **Vollmer Substation**

Basin ID: **PR-3 (Design Point 3)**

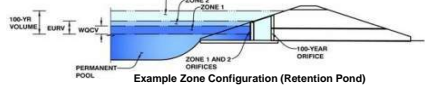

Required Volume Calculation

Selected BMP Type =	SF
Watershed Area =	1.70 acres
Watershed Length =	180 ft
Watershed Slope =	0.010 ft/ft
Watershed Imperviousness =	40.00% percent
Percentage Hydrologic Soil Group A =	100.0% percent
Percentage Hydrologic Soil Group B =	0.0% percent
Percentage Hydrologic Soil Groups C/D =	0.0% percent
Desired WQC Drain Time =	40.0 hours
Location for 1-hr Rainfall Depths =	Denver - Capitol Building
Water Quality Capture Volume (WQC) =	0.020 acre-feet
Excess Urban Runoff Volume (EURV) =	0.074 acre-feet
2-yr Runoff Volume (P1 = 1.19 in.) =	0.050 acre-feet
5-yr Runoff Volume (P1 = 1.5 in.) =	0.066 acre-feet
10-yr Runoff Volume (P1 = 1.75 in.) =	0.082 acre-feet
25-yr Runoff Volume (P1 = 2 in.) =	0.105 acre-feet
50-yr Runoff Volume (P1 = 2.25 in.) =	0.136 acre-feet
100-yr Runoff Volume (P1 = 2.52 in.) =	0.175 acre-feet
500-yr Runoff Volume (P1 = 3.14 in.) =	0.265 acre-feet
Approximate 2-yr Detention Volume =	0.047 acre-feet
Approximate 5-yr Detention Volume =	0.062 acre-feet
Approximate 10-yr Detention Volume =	0.077 acre-feet
Approximate 25-yr Detention Volume =	0.095 acre-feet
Approximate 50-yr Detention Volume =	0.107 acre-feet
Approximate 100-yr Detention Volume =	0.125 acre-feet

Note: L / W Ratio < 1
L / W Ratio = 0.4

Drain Time Too Long

Optional User Override 1-hr Precipitation

1.19	inches
1.50	inches
1.75	inches
2.00	inches
2.25	inches
2.52	inches

Stage-Storage Calculation

Zone 1 Volume (WQC) =	0.020 acre-feet
Select Zone 2 Storage Volume (Optional) =	acre-feet
Select Zone 3 Storage Volume (Optional) =	acre-feet
Total Detention Basin Volume =	0.020 acre-feet
Initial Surcharge Volume (ISV) =	N/A tr ³
Initial Surcharge Depth (ISD) =	N/A ft
Total Available Detention Depth (H _{total}) =	1.00 ft
Depth of Trickle Channel (H _{TC}) =	N/A ft
Slope of Trickle Channel (S _{TC}) =	N/A ft/ft
Slopes of Main Basin Sides (S _{main}) =	4:01 H:V
Basin Length-to-Width Ratio (R _{L/W}) =	4
Initial Surcharge Area (A _{sv}) =	0 tr ²
Surcharge Volume Length (L _{sv}) =	0.0 ft
Surcharge Volume Width (W _{sv}) =	0.0 ft
Depth of Basin Floor (H _{1,000}) =	0.00 ft
Length of Basin Floor (L _{1,000}) =	59.2 ft
Width of Basin Floor (W _{1,000}) =	14.8 ft
Area of Basin Floor (A _{1,000}) =	875 tr ²
Volume of Basin Floor (V _{1,000}) =	0 tr ³
Depth of Main Basin (H _{main}) =	1.00 ft
Length of Main Basin (L _{main}) =	59.5 ft
Width of Main Basin (W _{main}) =	15.1 ft
Area of Main Basin (A _{main}) =	900 tr ²
Volume of Main Basin (V _{main}) =	888 tr ³
Calculated Total Basin Volume (V _{total}) =	0.020 acre-feet

Total detention volume is less than 100-year volume.

Smain not typical.

Stage - Storage Description	Stage (ft)	Optional Override Stage (ft)	Length (ft)	Width (ft)	Area (ft ²)	Optional Override Area (ft ²)	Area (acre)	Volume (ft ³)	Volume (ac-ft)
Media Surface	0.00		59.2	14.8	875				
	0.10		59.2	14.8	878		0.020	88	0.002
	0.20		59.2	14.9	880		0.020	167	0.004
	0.30		59.3	14.9	883		0.020	255	0.006
	0.40		59.3	14.9	885		0.020	343	0.008
	0.50		59.3	15.0	888		0.020	432	0.010
	0.60		59.4	15.0	890		0.020	521	0.012
	0.70		59.4	15.0	893		0.020	610	0.014
	0.80		59.4	15.1	895		0.021	699	0.016
	0.90		59.5	15.1	898		0.021	789	0.018
	1.00		59.5	15.1	900		0.021	879	0.020
Zone 1 (WQC)	1.00		59.5	15.1	900		0.021	888	0.020
	1.10		59.5	15.2	903		0.021	969	0.022
	1.20		59.6	15.2	905		0.021	1,059	0.024
	1.30		59.6	15.2	908		0.021	1,150	0.026
	1.40		59.6	15.3	910		0.021	1,241	0.028
	1.50		59.7	15.3	913		0.021	1,332	0.031
	1.60		59.7	15.3	915		0.021	1,423	0.033
	1.70		59.7	15.4	918		0.021	1,515	0.035
	1.80		59.8	15.4	920		0.021	1,607	0.037
	1.90		59.8	15.4	923		0.021	1,699	0.039
	2.00		59.8	15.5	925		0.021	1,791	0.041
	2.10		59.9	15.5	928		0.021	1,883	0.043
	2.20		59.9	15.5	930		0.021	1,986	0.046
	2.30		59.9	15.6	933		0.021	2,079	0.048
	2.40		60.0	15.6	935		0.021	2,173	0.050
	2.50		60.0	15.6	938		0.022	2,267	0.052
	2.60		60.0	15.7	941		0.022	2,360	0.054
	2.70		60.1	15.7	943		0.022	2,455	0.056
	2.80		60.1	15.7	946		0.022	2,549	0.059
	2.90		60.1	15.8	948		0.022	2,644	0.061
	3.00		60.2	15.8	951		0.022	2,739	0.063
	3.10		60.2	15.8	953		0.022	2,834	0.065
	3.20		60.2	15.9	956		0.022	2,929	0.067
	3.30		60.3	15.9	958		0.022	3,025	0.069
	3.40		60.3	15.9	961		0.022	3,121	0.072
	3.50		60.3	16.0	963		0.022	3,217	0.074
	3.60		60.4	16.0	966		0.022	3,314	0.076
	3.70		60.4	16.0	969		0.022	3,410	0.078
	3.80		60.4	16.1	971		0.022	3,507	0.081
	3.90		60.5	16.1	974		0.022	3,605	0.083
	4.00		60.5	16.1	976		0.022	3,702	0.085
	4.10		60.5	16.2	979		0.022	3,800	0.087
	4.20		60.6	16.2	981		0.023	3,898	0.089
	4.30		60.6	16.2	984		0.023	3,996	0.092
	4.40		60.6	16.3	987		0.023	4,095	0.094
	4.50		60.7	16.3	989		0.023	4,194	0.096
	4.60		60.7	16.3	992		0.023	4,293	0.099
	4.70		60.7	16.4	994		0.023	4,392	0.101
	4.80		60.8	16.4	997		0.023	4,491	0.103
	4.90		60.8	16.4	999		0.023	4,591	0.105
	5.00		60.8	16.5	1,002		0.023	4,691	0.108
	5.10		60.9	16.5	1,005		0.023	4,792	0.110
	5.20		60.9	16.5	1,007		0.023	4,892	0.112
	5.30		60.9	16.6	1,010		0.023	4,993	0.115
	5.40		61.0	16.6	1,012		0.023	5,094	0.117
	5.50		61.0	16.6	1,015		0.023	5,196	0.119
	5.60		61.0	16.7	1,018		0.023	5,297	0.122
	5.70		61.1	16.7	1,020		0.023	5,399	0.124
	5.80		61.1	16.7	1,023		0.023	5,501	0.126
	5.90		61.2	16.8	1,025		0.024	5,604	0.129
	6.00		61.2	16.8	1,028		0.024	5,706	0.131
	6.10		61.2	16.8	1,031		0.024	5,809	0.133
	6.20		61.3	16.9	1,033		0.024	5,912	0.136
	6.30		61.3	16.9	1,036		0.024	6,016	0.138
	6.40		61.3	16.9	1,038		0.024	6,120	0.140
	6.50		61.4	17.0	1,041		0.024	6,224	0.143
	6.60		61.4	17.0	1,044		0.024	6,328	0.145
	6.70		61.4	17.0	1,046		0.024	6,432	0.148
	6.80		61.5	17.1	1,049		0.024	6,537	0.150
	6.90		61.5	17.1	1,052		0.024	6,642	0.152
	7.00		61.5	17.1	1,054		0.024	6,747	0.155
	7.10		61.6	17.2	1,057		0.024	6,853	0.157
	7.20		61.6	17.2	1,060		0.024	6,959	0.160
	7.30		61.6	17.2	1,062		0.024	7,065	0.162
	7.40		61.7	17.3	1,065		0.024	7,171	0.165
	7.50		61.7	17.3	1,067		0.025	7,278	0.167
	7.60		61.7	17.3	1,070		0.025	7,385	0.170
	7.70		61.8	17.4	1,073		0.025	7,492	0.172
	7.80		61.8	17.4	1,075		0.025	7,599	0.174
	7.90		61.8	17.4	1,078		0.025	7,707	0.177
	8.00		61.9	17.5	1,081		0.025	7,815	0.179
	8.10		61.9	17.5	1,083		0.025	7,923	0.182
	8.20		61.9	17.5	1,086		0.025	8,032	0.184
	8.30		62.0	17.6	1,089		0.025	8,140	0.187
	8.40		62.0	17.6	1,091		0.025	8,249	0.189
	8.50		62.0	17.6	1,094		0.025	8,359	0.192
	8.60		62.1	17.7	1,097		0.025	8,468	0.194
	8.70		62.1	17.7	1,099		0.025	8,578	0.197
	8.80		62.1	17.7	1,102		0.025	8,688	0.199
	8.90		62.2	17.8	1,105		0.025	8,798	0.202
	9.00		62.2	17.8	1,107		0.025	8,909	0.205
	9.10		62.2	17.8	1,110		0.025	9,020	0.207
	9.20		62.3	17.9	1,113		0.026	9,131	0.210
	9.30		62.3	17.9	1,115		0.026	9,242	0.212
	9.40		62.3	17.9	1,118		0.026	9,354	0.215
	9.50		62.4	18.0	1,121		0.026	9,466	0.217
	9.60		62.4	18.0	1,123		0.026	9,578	0.220
	9.70		62.4	18.0	1,126				

DETENTION BASIN STAGE-STORAGE TABLE BUILDER

UD-Detention, Version 3.07 (February 2017)

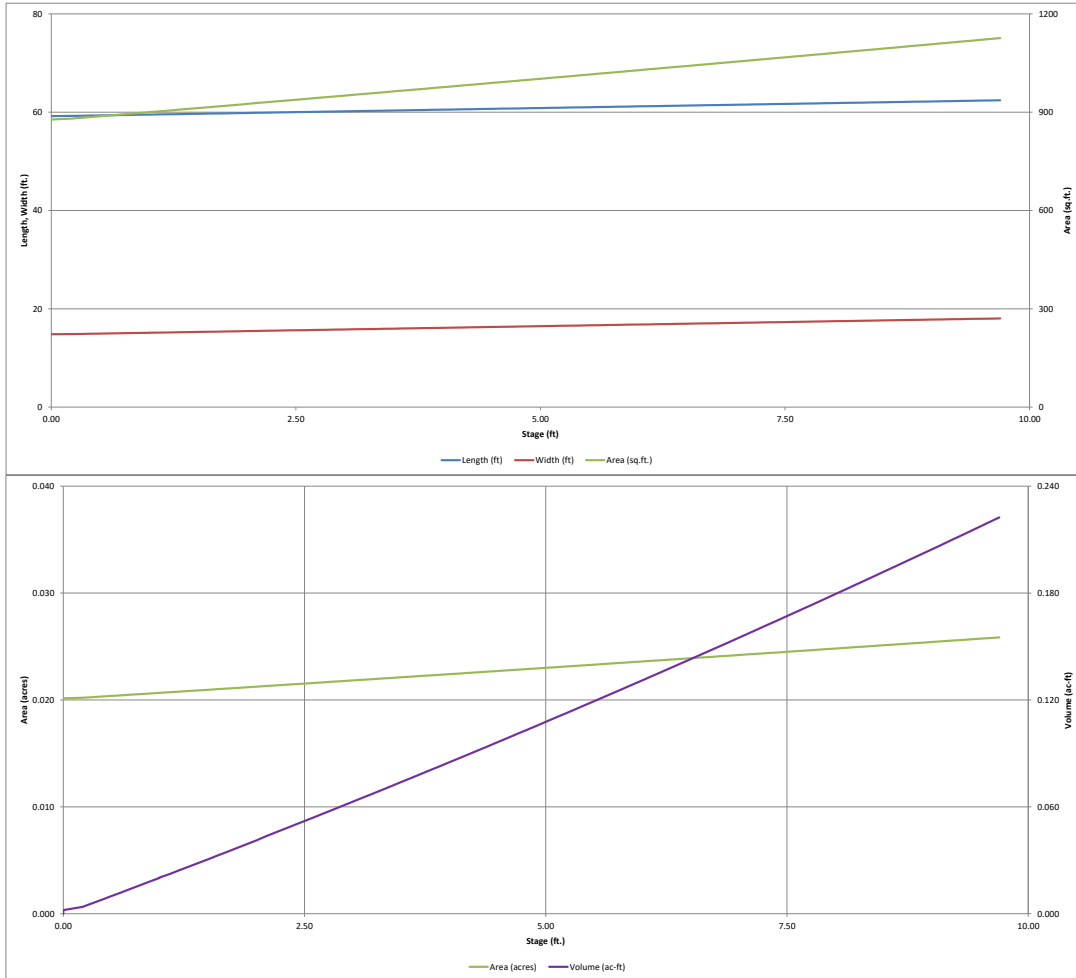

Detention Basin Outlet Structure Design

UD-Detention, Version 3.07 (February 2017)

Project: Vollmer Substation
Basin ID: PR-3 (Design Point 3)

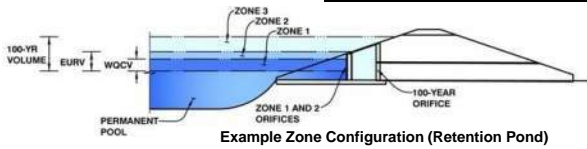

Example Zone Configuration (Retention Pond)

	Stage (ft)	Zone Volume (ac-ft)	Outlet Type
Zone 1 (WQCV)	1.00	0.020	Filtration Media
Zone 2			Weir&Pipe (Circular)
Zone 3			
		0.020	Total

User Input: Orifice at Underdrain Outlet (typically used to drain WQCV in a Filtration BMP)

Underdrain Orifice Invert Depth =	2.17	ft (distance below the filtration media surface)
Underdrain Orifice Diameter =	0.37	inches

Calculated Parameters for Underdrain

Underdrain Orifice Area =	0.0	ft ²
Underdrain Orifice Centroid =	0.02	feet

User Input: Orifice Plate with one or more orifices or Elliptical Slot Weir (typically used to drain WQCV and/or EURV in a sedimentation BMP)

Invert of Lowest Orifice =	N/A	ft (relative to basin bottom at Stage = 0 ft)
Depth at top of Zone using Orifice Plate =	N/A	ft (relative to basin bottom at Stage = 0 ft)
Orifice Plate: Orifice Vertical Spacing =	N/A	inches
Orifice Plate: Orifice Area per Row =	N/A	inches

Calculated Parameters for Plate

WQ Orifice Area per Row =	N/A	ft ²
Elliptical Half-Width =	N/A	feet
Elliptical Slot Centroid =	N/A	feet
Elliptical Slot Area =	N/A	ft ²

User Input: Stage and Total Area of Each Orifice Row (numbered from lowest to highest)

	Row 1 (optional)	Row 2 (optional)	Row 3 (optional)	Row 4 (optional)	Row 5 (optional)	Row 6 (optional)	Row 7 (optional)	Row 8 (optional)
Stage of Orifice Centroid (ft)	N/A	N/A	N/A	N/A	N/A	N/A	N/A	N/A
Orifice Area (sq. inches)	N/A	N/A	N/A	N/A	N/A	N/A	N/A	N/A

	Row 9 (optional)	Row 10 (optional)	Row 11 (optional)	Row 12 (optional)	Row 13 (optional)	Row 14 (optional)	Row 15 (optional)	Row 16 (optional)
Stage of Orifice Centroid (ft)	N/A	N/A	N/A	N/A	N/A	N/A	N/A	N/A
Orifice Area (sq. inches)	N/A	N/A	N/A	N/A	N/A	N/A	N/A	N/A

User Input: Vertical Orifice (Circular or Rectangular)

	Not Selected	Not Selected	
Invert of Vertical Orifice =			ft (relative to basin bottom at Stage = 0 ft)
Depth at top of Zone using Vertical Orifice =			ft (relative to basin bottom at Stage = 0 ft)
Vertical Orifice Diameter =			inches

Calculated Parameters for Vertical Orifice

	Not Selected	Not Selected	
Vertical Orifice Area =			ft ²
Vertical Orifice Centroid =			feet

User Input: Overflow Weir (Dropbox) and Grate (Flat or Sloped)

	Zone 2 Weir	Not Selected	
Overflow Weir Front Edge Height, Ho =	1.00		ft (relative to basin bottom at Stage = 0 ft)
Overflow Weir Front Edge Length =	2.00		feet
Overflow Weir Slope =	0.00		H:V (enter zero for flat grate)
Horiz. Length of Weir Sides =	2.00		feet
Overflow Grate Open Area % =	70%		% grate open area/total area
Debris Clogging % =	50%		%

Calculated Parameters for Overflow Weir

	Zone 2 Weir	Not Selected	
Height of Grate Upper Edge, H _g =	1.00		feet
Over Flow Weir Slope Length =	2.00		feet
Grate Open Area / 100-yr Orifice Area =	1.58		should be ≥ 4
Overflow Grate Open Area w/o Debris =	2.80		ft ²
Overflow Grate Open Area w/ Debris =	1.40		ft ²

User Input: Outlet Pipe w/ Flow Restriction Plate (Circular Orifice, Restrictor Plate, or Rectangular Orifice)

	Zone 2 Circular	Not Selected	
Depth to Invert of Outlet Pipe =	2.50		ft (distance below basin bottom at Stage = 0 ft)
Circular Orifice Diameter =	18.00		inches

Calculated Parameters for Outlet Pipe w/ Flow Restriction Plate

	Zone 2 Circular	Not Selected	
Outlet Orifice Area =	1.77		ft ²
Outlet Orifice Centroid =	0.75		feet
Half-Central Angle of Restrictor Plate on Pipe =	N/A	N/A	radians

User Input: Emergency Spillway (Rectangular or Trapezoidal)

Spillway Invert Stage =		ft (relative to basin bottom at Stage = 0 ft)
Spillway Crest Length =		feet
Spillway End Slopes =		H:V
Freeboard above Max Water Surface =		feet

Calculated Parameters for Spillway

Spillway Design Flow Depth =		feet
Stage at Top of Freeboard =		feet
Basin Area at Top of Freeboard =		acres

Routed Hydrograph Results

	WQCV	EURV	2 Year	5 Year	10 Year	25 Year	50 Year	100 Year	500 Year
Design Storm Return Period =									
One-Hour Rainfall Depth (in) =	0.53	1.07	1.19	1.50	1.75	2.00	2.25	2.52	3.14
Calculated Runoff Volume (acre-ft) =	0.020	0.074	0.050	0.066	0.082	0.105	0.136	0.175	0.265
OPTIONAL Override Runoff Volume (acre-ft) =									
Inflow Hydrograph Volume (acre-ft) =	0.020	0.073	0.049	0.065	0.081	0.104	0.136	0.175	0.265
Predevelopment Unit Peak Flow, q (cfs/acre) =	0.00	0.00	0.00	0.01	0.01	0.03	0.23	0.56	1.25
Predevelopment Peak Q (cfs) =	0.0	0.0	0.0	0.0	0.0	0.1	0.4	0.9	2.1
Peak Inflow Q (cfs) =	0.5	1.8	1.2	1.6	2.0	2.6	3.3	4.3	6.5
Peak Outflow Q (cfs) =	0.0	1.7	1.0	1.5	1.9	2.7	3.6	4.2	6.5
Ratio Peak Outflow to Predevelopment Q =	N/A	N/A	N/A	144.1	80.3	53.1	9.1	4.5	3.1
Structure Controlling Flow =	Filtration Media	Overflow Grate 1	Overflow Grate 1	Overflow Grate 1	Overflow Grate 1	Overflow Grate 1	Overflow Grate 1	Overflow Grate 1	Overflow Grate 1
Max Velocity through Grate 1 (fps) =	N/A	0.59	0.29	0.5	0.6	0.9	1.2	1.5	2.3
Max Velocity through Grate 2 (fps) =	N/A	N/A	N/A	N/A	N/A	N/A	N/A	N/A	N/A
Time to Drain 97% of Inflow Volume (hours) =	40	39	41	40	39	37	35	33	27
Time to Drain 99% of Inflow Volume (hours) =	40	43	43	43	42	42	41	40	38
Maximum Ponding Depth (ft) =	0.92	1.22	1.14	1.19	1.23	1.29	1.35	1.40	1.65
Area at Maximum Ponding Depth (acres) =	0.02	0.02	0.02	0.02	0.02	0.02	0.02	0.02	0.02
Maximum Volume Stored (acre-ft) =	0.019	0.025	0.023	0.024	0.025	0.026	0.028	0.029	0.034

Detention Basin Outlet Structure Design

UD-Detention, Version 3.07 (February 2017)

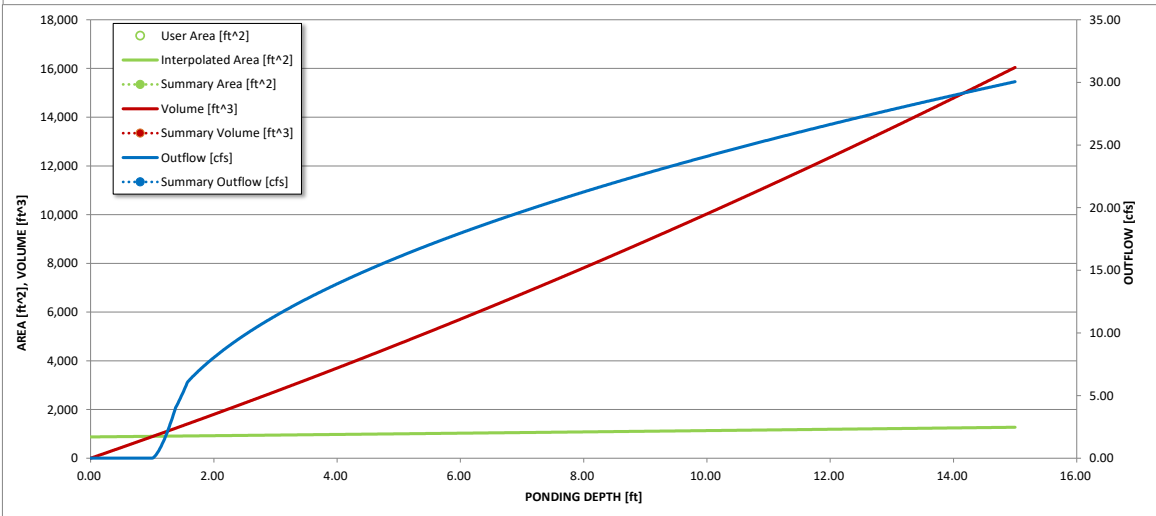
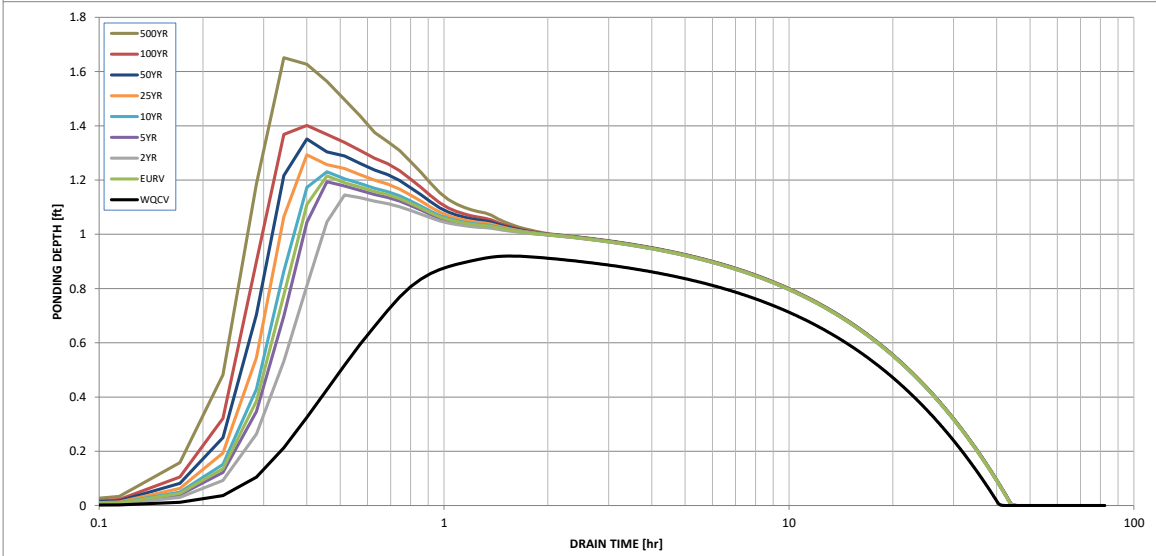
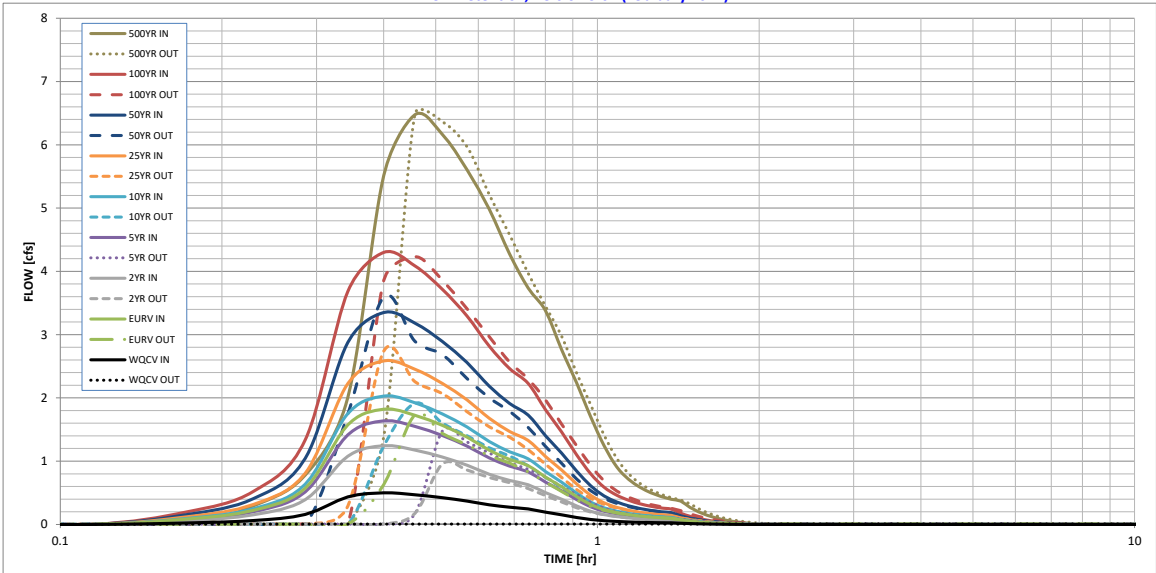

S-A-V-D Chart Axis Override

	X-axis	Left Y-Axis	Right Y-Axis
minimum bound			
maximum bound			

DETENTION BASIN STAGE-STORAGE TABLE BUILDER

MHFD-*Detention*, Version 4.06 (July 2022)

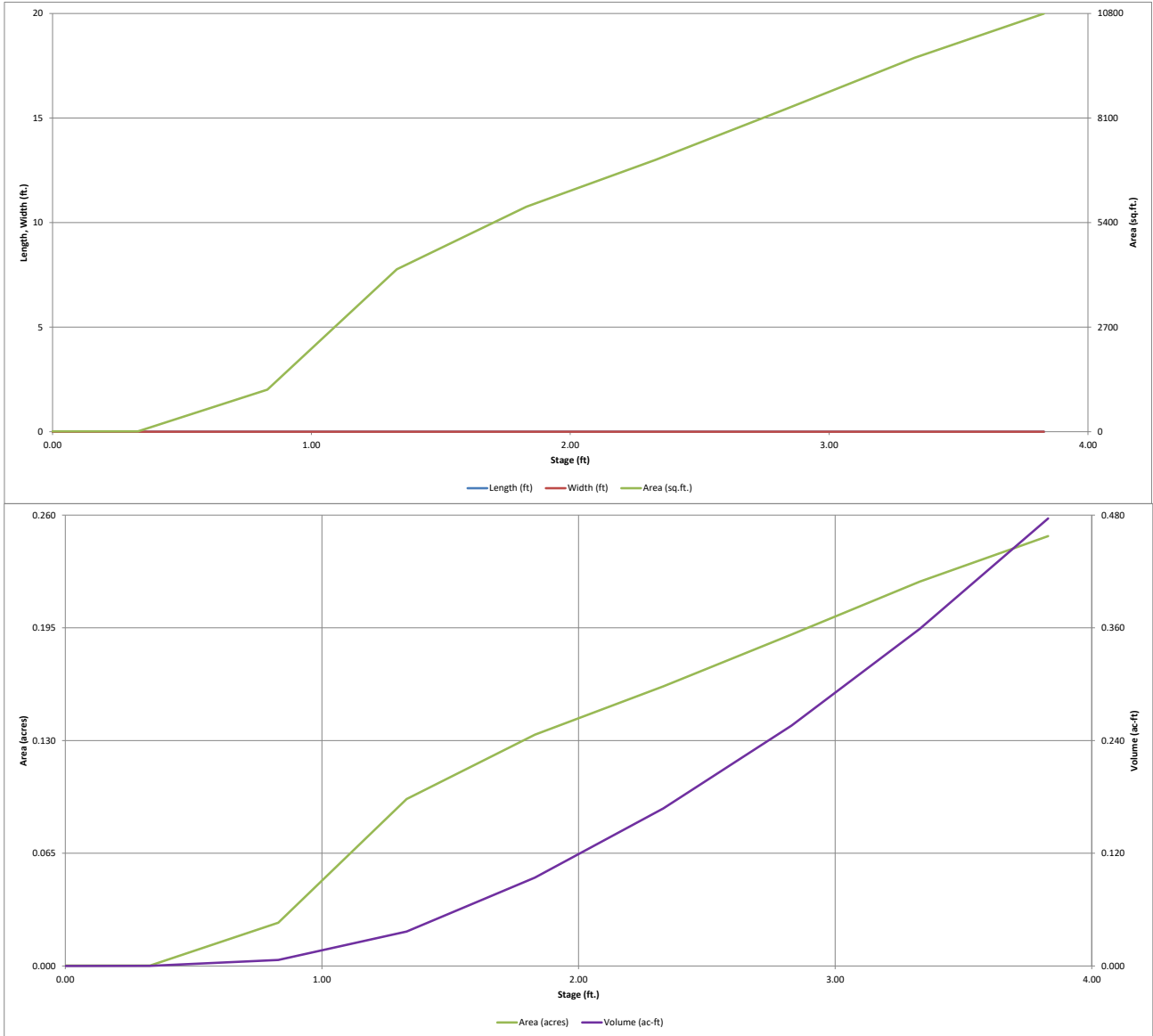

✓ = calcs match details in plans
 X = calcs do not match details in plans

DETENTION BASIN OUTLET STRUCTURE DESIGN

MHFD-Detention, Version 4.06 (July 2022)

Project: Vollmer Substation
Basin ID: Detention Pond

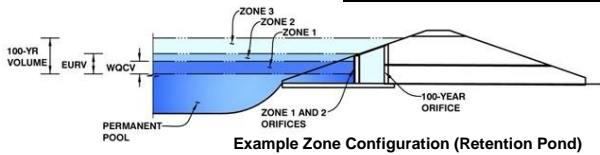

	Estimated Stage (ft)	Estimated Volume (ac-ft)	Outlet Type
Zone 1 (WQCV)	1.21	0.025	Orifice Plate
Zone 2 (EURV)	1.67	0.048	Orifice Plate
Zone 3 (100-year)	2.05	0.050	Weir&Pipe (Restrict)
Total (all zones)		0.124	

User Input: Orifice at Underdrain Outlet (typically used to drain WQCV in a Filtration BMP)

Underdrain Orifice Invert Depth = ft (distance below the filtration media surface)
 Underdrain Orifice Diameter = inches

Calculated Parameters for Underdrain
 Underdrain Orifice Area = ft²
 Underdrain Orifice Centroid = feet

User Input: Orifice Plate with one or more orifices or Elliptical Slot Weir (typically used to drain WQCV and/or EURV in a sedimentation BMP)

Centroid of Lowest Orifice = ft (relative to basin bottom at Stage = 0 ft)
 Depth at top of Zone using Orifice Plate = ft (relative to basin bottom at Stage = 0 ft)
 Orifice Plate: Orifice Vertical Spacing = inches
 Orifice Plate: Orifice Area per Row = sq. inches (diameter = 1/2 inch)

Calculated Parameters for Plate
 WQ Orifice Area per Row = ft²
 Elliptical Half-Width = feet
 Elliptical Slot Centroid = feet
 Elliptical Slot Area = ft²

User Input: Stage and Total Area of Each Orifice Row (numbered from lowest to highest)

	Row 1 (required)	Row 2 (optional)	Row 3 (optional)	Row 4 (optional)	Row 5 (optional)	Row 6 (optional)	Row 7 (optional)	Row 8 (optional)
Stage of Orifice Centroid (ft)	0.00	0.50	1.00	1.50				
Orifice Area (sq. inches)	0.20	0.20	0.20	0.20				

	Row 9 (optional)	Row 10 (optional)	Row 11 (optional)	Row 12 (optional)	Row 13 (optional)	Row 14 (optional)	Row 15 (optional)	Row 16 (optional)
Stage of Orifice Centroid (ft)								
Orifice Area (sq. inches)								

User Input: Vertical Orifice (Circular or Rectangular)

Invert of Vertical Orifice = ft (relative to basin bottom at Stage = 0 ft)
 Depth at top of Zone using Vertical Orifice = ft (relative to basin bottom at Stage = 0 ft)
 Vertical Orifice Diameter = inches

Calculated Parameters for Vertical Orifice
 Vertical Orifice Area = ft²
 Vertical Orifice Centroid = feet

User Input: Overflow Weir (Dropbox with Flat or Sloped Grate and Outlet Pipe OR Rectangular/Trapezoidal Weir and No Outlet Pipe)

Overflow Weir Front Edge Height, Ho = ft (relative to basin bottom at Stage = 0 ft)
 Overflow Weir Front Edge Length = feet
 Overflow Weir Grate Slope = H:V
 Horiz. Length of Weir Sides = feet
 Overflow Grate Type =
 Debris Clogging % = %

Calculated Parameters for Overflow Weir
 Height of Grate Upper Edge, H_u = feet
 Overflow Weir Slope Length = feet
 Grate Open Area / 100-yr Orifice Area =
 Overflow Grate Open Area w/o Debris = ft²
 Overflow Grate Open Area w/ Debris = ft²

User Input: Outlet Pipe w/ Flow Restriction Plate (Circular Orifice, Restrictor Plate, or Rectangular Orifice)

Depth to Invert of Outlet Pipe = ft (distance below basin bottom at Stage = 0 ft)
 Outlet Pipe Diameter = inches
 Restrictor Plate Height Above Pipe Invert = inches

Calculated Parameters for Outlet Pipe w/ Flow Restriction Plate
 Outlet Orifice Area = ft²
 Outlet Orifice Centroid = feet
 Restrictor Plate on Pipe = radians

User Input: Emergency Spillway (Rectangular or Trapezoidal)

Spillway Invert Stage = ft (relative to basin bottom at Stage = 0 ft)
 Spillway Crest Length = feet
 Spillway End Slopes = H:V
 Freeboard above Max Water Surface = feet

Calculated Parameters for Spillway
 Design Flow Depth = feet
 Top of Freeboard = feet
 Basin Area at Top of Freeboard = acres
 Basin Volume at Top of Freeboard = acre-ft

A spillway is necessary, please input values here and see my comment on the CDs

Routed Hydrograph Results

The user can override the default CUHP hydrographs and runoff volumes by entering new values in the Inflow Hydrographs table (Columns W through AF).

	WQCV	EURV	2 Year	5 Year	10 Year	25 Year	50 Year	100 Year	500 Year
Design Storm Return Period	N/A	N/A	1.19	1.50	1.75	2.00	2.25	2.50	3.14
One-Hour Rainfall Depth (in)	0.025	0.074	0.049	0.066	0.080	0.105	0.129	0.159	0.230
CUHP Runoff Volume (acre-ft)	N/A	N/A	0.049	0.066	0.080	0.105	0.129	0.159	0.230
Inflow Hydrograph Volume (acre-ft)	N/A	N/A	0.0	0.1	0.1	0.7	1.3	2.1	3.7
CUHP Predevelopment Peak Q (cfs)	N/A	N/A							
OPTIONAL Override Predevelopment Peak Q (cfs)	N/A	N/A							
Predevelopment Unit Peak Flow, q (cfs/acre)	N/A	N/A	0.02	0.03	0.04	0.41	0.77	1.23	2.18
Peak Inflow Q (cfs)	N/A	N/A	1.1	1.6	2.0	2.7	3.5	4.3	6.3
Peak Outflow Q (cfs)	0.0	0.0	0.0	0.0	0.0	0.1	0.3	0.8	2.3
Ratio Peak Outflow to Predevelopment Q	N/A	N/A	N/A	0.4	0.3	0.1	0.2	0.4	0.6
Structure Controlling Flow	Plate	Plate	Plate	Plate	Plate	Overflow Weir 1	Overflow Weir 1	Overflow Weir 1	Overflow Weir 1
Max Velocity through Grate 1 (fps)	N/A	N/A	N/A	N/A	N/A	0.0	0.0	0.1	0.3
Max Velocity through Grate 2 (fps)	N/A	N/A	N/A	N/A	N/A	N/A	N/A	N/A	N/A
Time to Drain 97% of Inflow Volume (hours)	26	54	42	51	57	66	65	64	61
Time to Drain 99% of Inflow Volume (hours)	27	57	44	53	60	69	69	69	68
Maximum Ponding Depth (ft)	1.20	1.68	1.43	1.58	1.69	1.87	1.93	2.02	2.18
Area at Maximum Ponding Depth (acres)	0.08	0.12	0.10	0.11	0.12	0.14	0.14	0.14	0.15
Maximum Volume Stored (acre-ft)	0.025	0.075	0.046	0.062	0.075	0.098	0.108	0.119	0.144

these values should be closer to 40hrs. Please try to revise inputs to accomplish this.

DETENTION BASIN OUTLET STRUCTURE DESIGN

MHFD-Detention, Version 4.06 (July 2022)

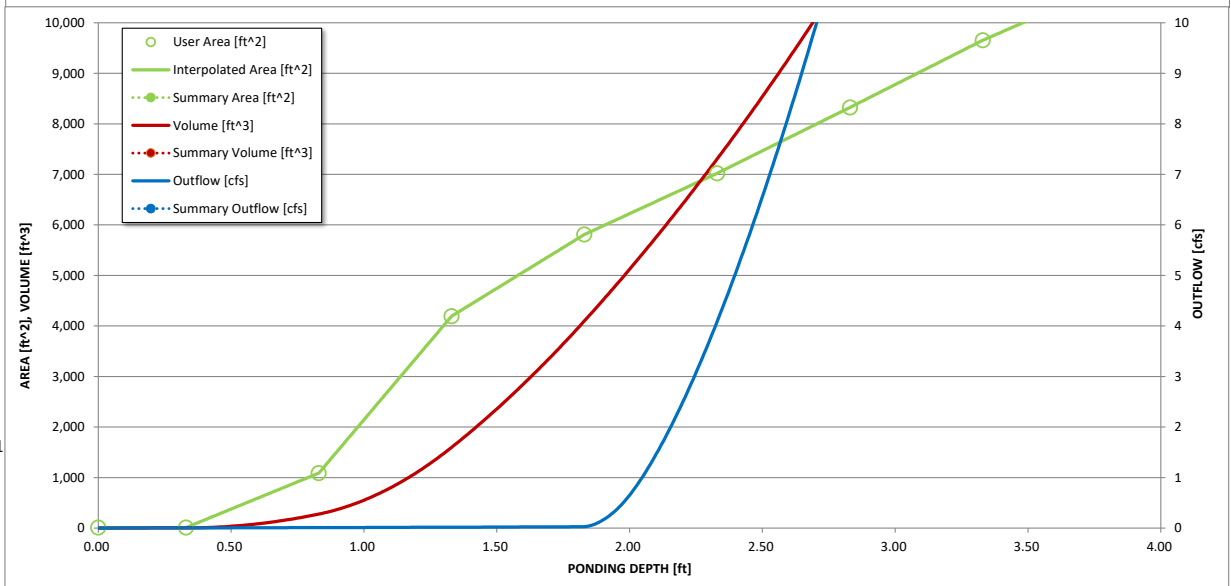
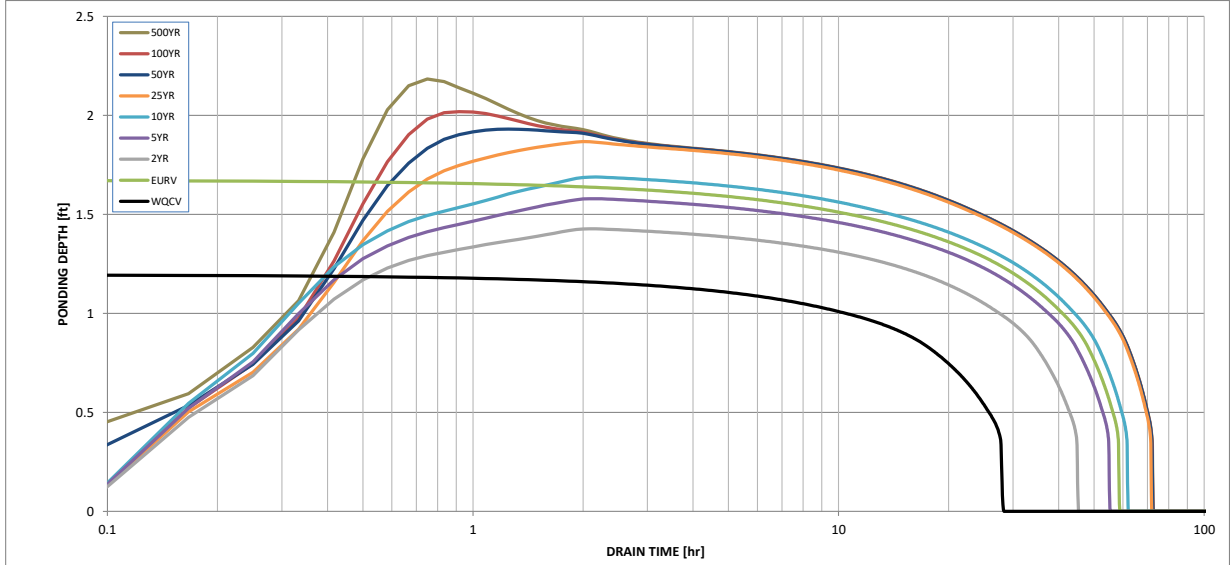
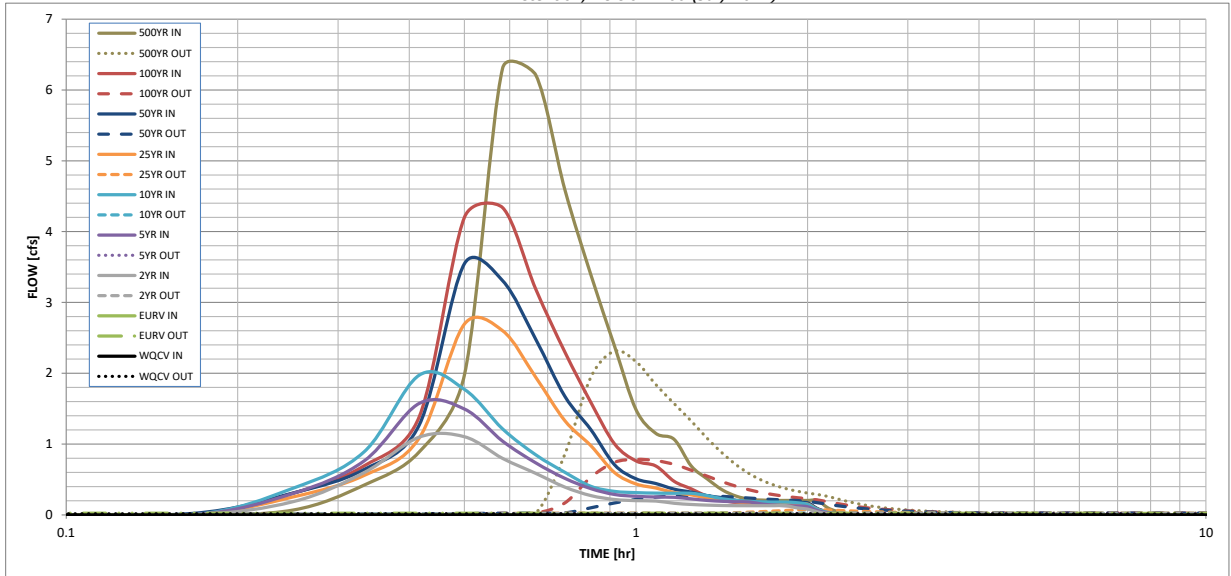

S-A-V-D Chart Axis Override	X-axis	Left Y-Axis	Right Y-Axis
minimum bound			
maximum bound			

DETENTION BASIN OUTLET STRUCTURE DESIGN

Outflow Hydrograph Workbook Filename: _____

Inflow Hydrographs

The user can override the calculated inflow hydrographs from this workbook with inflow hydrographs developed in a separate program.

Time Interval	SOURCE	CUHP	CUHP	CUHP	CUHP	CUHP	CUHP	CUHP	CUHP	CUHP
5.00 min	TIME	WQCV [cfs]	EURV [cfs]	2 Year [cfs]	5 Year [cfs]	10 Year [cfs]	25 Year [cfs]	50 Year [cfs]	100 Year [cfs]	500 Year [cfs]
	0:00:00	0.00	0.00	0.00	0.00	0.00	0.00	0.00	0.00	0.00
	0:05:00	0.00	0.00	0.00	0.00	0.00	0.00	0.00	0.00	0.00
	0:10:00	0.00	0.00	0.00	0.00	0.00	0.00	0.02	0.00	0.07
	0:15:00	0.00	0.00	0.19	0.30	0.38	0.25	0.31	0.31	0.42
	0:20:00	0.00	0.00	0.60	0.76	0.89	0.56	0.64	0.69	0.89
	0:25:00	0.00	0.00	1.10	1.58	1.97	1.09	1.27	1.39	1.98
	0:30:00	0.00	0.00	1.10	1.49	1.77	2.70	3.55	4.20	6.31
	0:35:00	0.00	0.00	0.80	1.04	1.21	2.60	3.31	4.34	6.21
	0:40:00	0.00	0.00	0.59	0.74	0.85	1.94	2.48	3.19	4.59
	0:45:00	0.00	0.00	0.39	0.52	0.60	1.33	1.68	2.30	3.39
	0:50:00	0.00	0.00	0.27	0.37	0.40	0.98	1.20	1.59	2.39
	0:55:00	0.00	0.00	0.22	0.29	0.33	0.60	0.71	1.00	1.49
	1:00:00	0.00	0.00	0.20	0.26	0.31	0.44	0.51	0.76	1.15
	1:05:00	0.00	0.00	0.20	0.25	0.31	0.38	0.44	0.69	1.07
	1:10:00	0.00	0.00	0.16	0.25	0.31	0.32	0.36	0.47	0.69
	1:15:00	0.00	0.00	0.15	0.23	0.31	0.28	0.32	0.37	0.51
	1:20:00	0.00	0.00	0.14	0.20	0.27	0.24	0.27	0.26	0.35
	1:25:00	0.00	0.00	0.13	0.19	0.23	0.22	0.24	0.21	0.26
	1:30:00	0.00	0.00	0.13	0.19	0.20	0.18	0.20	0.18	0.22
	1:35:00	0.00	0.00	0.13	0.18	0.19	0.17	0.19	0.17	0.21
	1:40:00	0.00	0.00	0.13	0.15	0.18	0.16	0.18	0.16	0.20
	1:45:00	0.00	0.00	0.13	0.14	0.18	0.15	0.17	0.16	0.20
	1:50:00	0.00	0.00	0.13	0.13	0.18	0.15	0.17	0.16	0.20
	1:55:00	0.00	0.00	0.10	0.13	0.17	0.15	0.17	0.16	0.20
	2:00:00	0.00	0.00	0.08	0.12	0.15	0.15	0.17	0.16	0.20
	2:05:00	0.00	0.00	0.04	0.06	0.08	0.08	0.09	0.08	0.10
	2:10:00	0.00	0.00	0.02	0.03	0.04	0.04	0.04	0.04	0.05
	2:15:00	0.00	0.00	0.01	0.01	0.02	0.02	0.02	0.02	0.02
	2:20:00	0.00	0.00	0.00	0.00	0.01	0.01	0.01	0.01	0.01
	2:25:00	0.00	0.00	0.00	0.00	0.00	0.00	0.00	0.00	0.00
	2:30:00	0.00	0.00	0.00	0.00	0.00	0.00	0.00	0.00	0.00
	2:35:00	0.00	0.00	0.00	0.00	0.00	0.00	0.00	0.00	0.00
	2:40:00	0.00	0.00	0.00	0.00	0.00	0.00	0.00	0.00	0.00
	2:45:00	0.00	0.00	0.00	0.00	0.00	0.00	0.00	0.00	0.00
	2:50:00	0.00	0.00	0.00	0.00	0.00	0.00	0.00	0.00	0.00
	2:55:00	0.00	0.00	0.00	0.00	0.00	0.00	0.00	0.00	0.00
	3:00:00	0.00	0.00	0.00	0.00	0.00	0.00	0.00	0.00	0.00
	3:05:00	0.00	0.00	0.00	0.00	0.00	0.00	0.00	0.00	0.00
	3:10:00	0.00	0.00	0.00	0.00	0.00	0.00	0.00	0.00	0.00
	3:15:00	0.00	0.00	0.00	0.00	0.00	0.00	0.00	0.00	0.00
	3:20:00	0.00	0.00	0.00	0.00	0.00	0.00	0.00	0.00	0.00
	3:25:00	0.00	0.00	0.00	0.00	0.00	0.00	0.00	0.00	0.00
	3:30:00	0.00	0.00	0.00	0.00	0.00	0.00	0.00	0.00	0.00
	3:35:00	0.00	0.00	0.00	0.00	0.00	0.00	0.00	0.00	0.00
	3:40:00	0.00	0.00	0.00	0.00	0.00	0.00	0.00	0.00	0.00
	3:45:00	0.00	0.00	0.00	0.00	0.00	0.00	0.00	0.00	0.00
	3:50:00	0.00	0.00	0.00	0.00	0.00	0.00	0.00	0.00	0.00
	3:55:00	0.00	0.00	0.00	0.00	0.00	0.00	0.00	0.00	0.00
	4:00:00	0.00	0.00	0.00	0.00	0.00	0.00	0.00	0.00	0.00
	4:05:00	0.00	0.00	0.00	0.00	0.00	0.00	0.00	0.00	0.00
	4:10:00	0.00	0.00	0.00	0.00	0.00	0.00	0.00	0.00	0.00
	4:15:00	0.00	0.00	0.00	0.00	0.00	0.00	0.00	0.00	0.00
	4:20:00	0.00	0.00	0.00	0.00	0.00	0.00	0.00	0.00	0.00
	4:25:00	0.00	0.00	0.00	0.00	0.00	0.00	0.00	0.00	0.00
	4:30:00	0.00	0.00	0.00	0.00	0.00	0.00	0.00	0.00	0.00
	4:35:00	0.00	0.00	0.00	0.00	0.00	0.00	0.00	0.00	0.00
	4:40:00	0.00	0.00	0.00	0.00	0.00	0.00	0.00	0.00	0.00
	4:45:00	0.00	0.00	0.00	0.00	0.00	0.00	0.00	0.00	0.00
	4:50:00	0.00	0.00	0.00	0.00	0.00	0.00	0.00	0.00	0.00
	4:55:00	0.00	0.00	0.00	0.00	0.00	0.00	0.00	0.00	0.00
	5:00:00	0.00	0.00	0.00	0.00	0.00	0.00	0.00	0.00	0.00
	5:05:00	0.00	0.00	0.00	0.00	0.00	0.00	0.00	0.00	0.00
	5:10:00	0.00	0.00	0.00	0.00	0.00	0.00	0.00	0.00	0.00
	5:15:00	0.00	0.00	0.00	0.00	0.00	0.00	0.00	0.00	0.00
	5:20:00	0.00	0.00	0.00	0.00	0.00	0.00	0.00	0.00	0.00
	5:25:00	0.00	0.00	0.00	0.00	0.00	0.00	0.00	0.00	0.00
	5:30:00	0.00	0.00	0.00	0.00	0.00	0.00	0.00	0.00	0.00
	5:35:00	0.00	0.00	0.00	0.00	0.00	0.00	0.00	0.00	0.00
	5:40:00	0.00	0.00	0.00	0.00	0.00	0.00	0.00	0.00	0.00
	5:45:00	0.00	0.00	0.00	0.00	0.00	0.00	0.00	0.00	0.00
	5:50:00	0.00	0.00	0.00	0.00	0.00	0.00	0.00	0.00	0.00
	5:55:00	0.00	0.00	0.00	0.00	0.00	0.00	0.00	0.00	0.00
	6:00:00	0.00	0.00	0.00	0.00	0.00	0.00	0.00	0.00	0.00

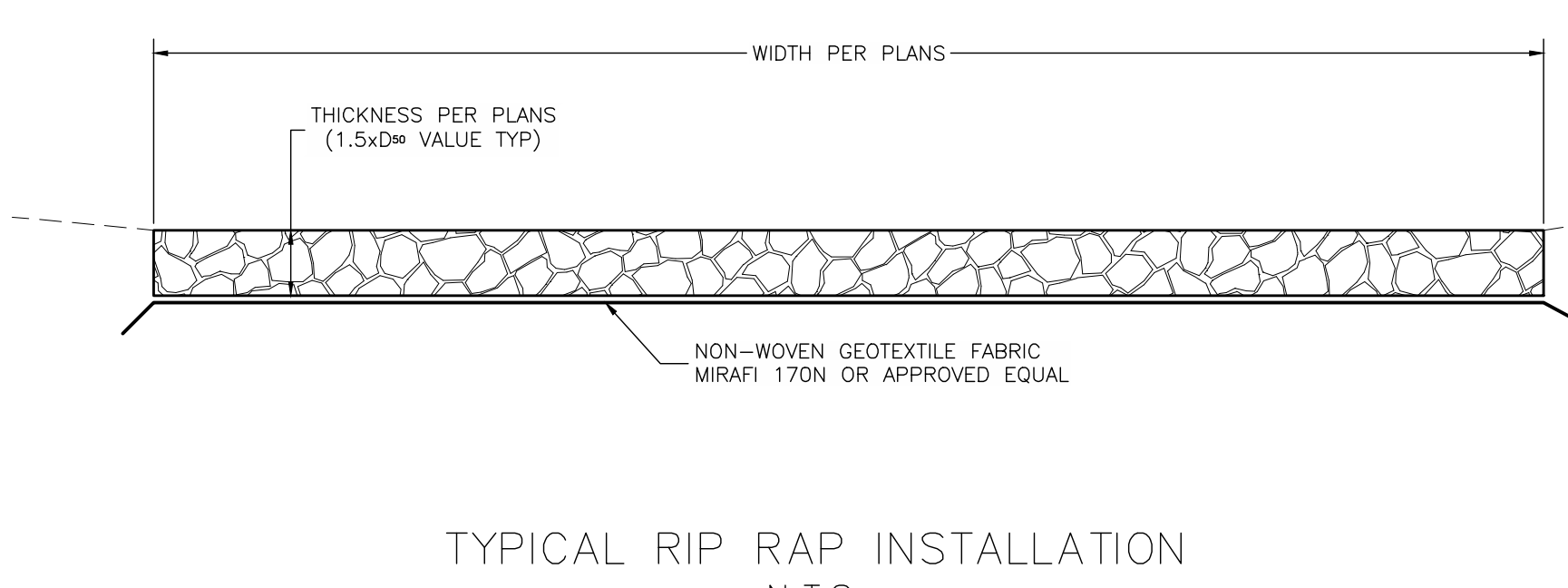
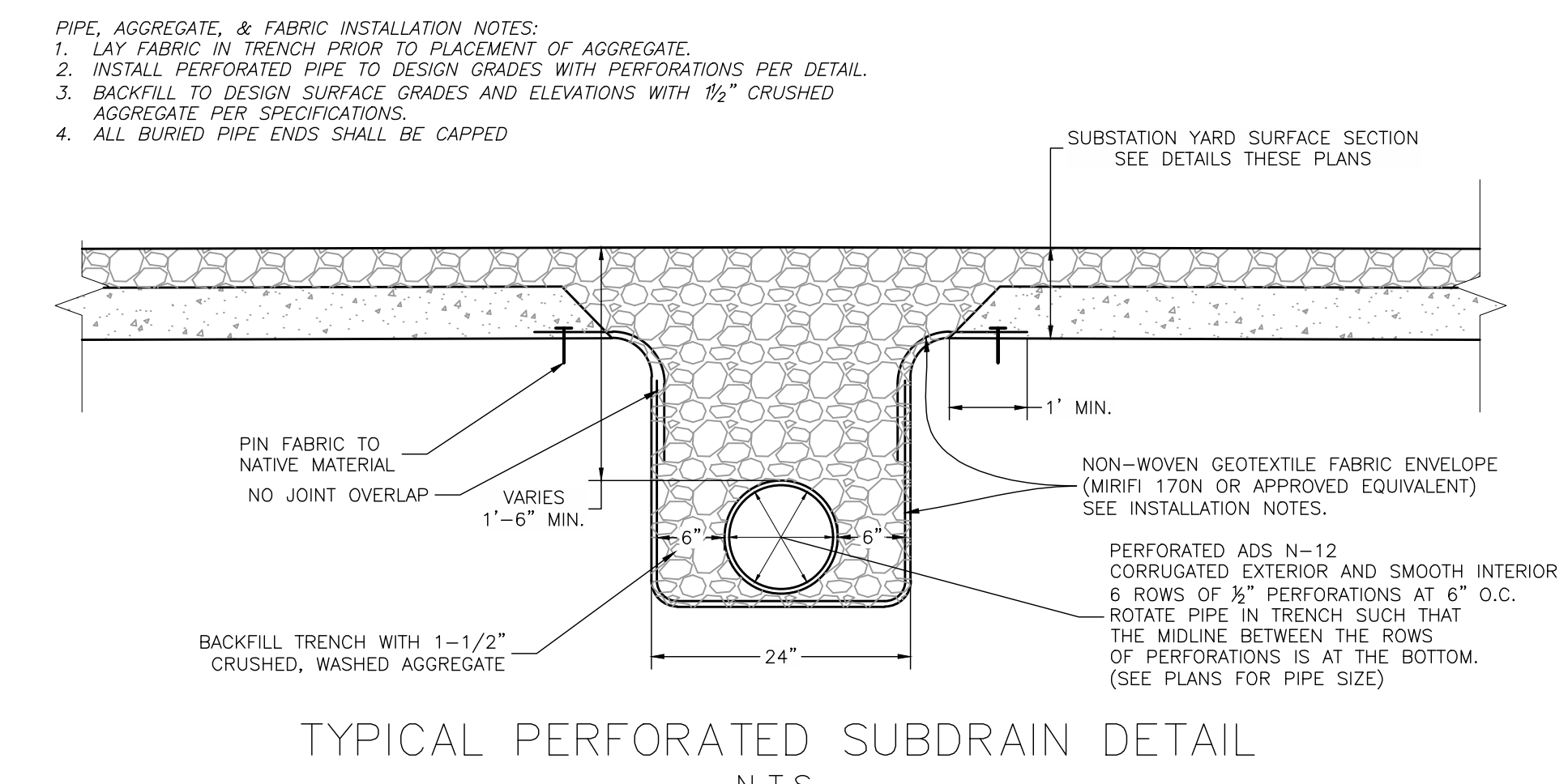
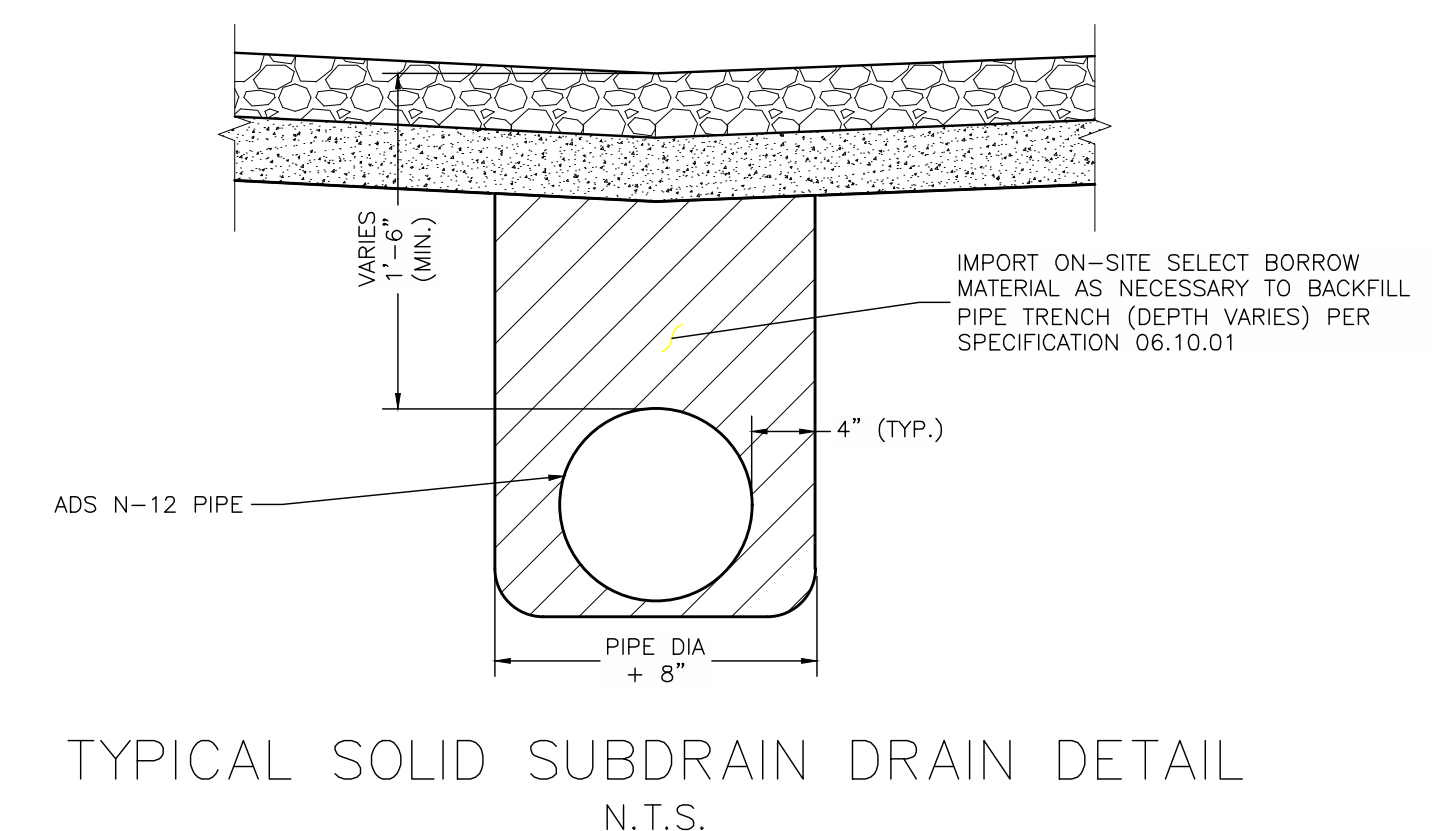
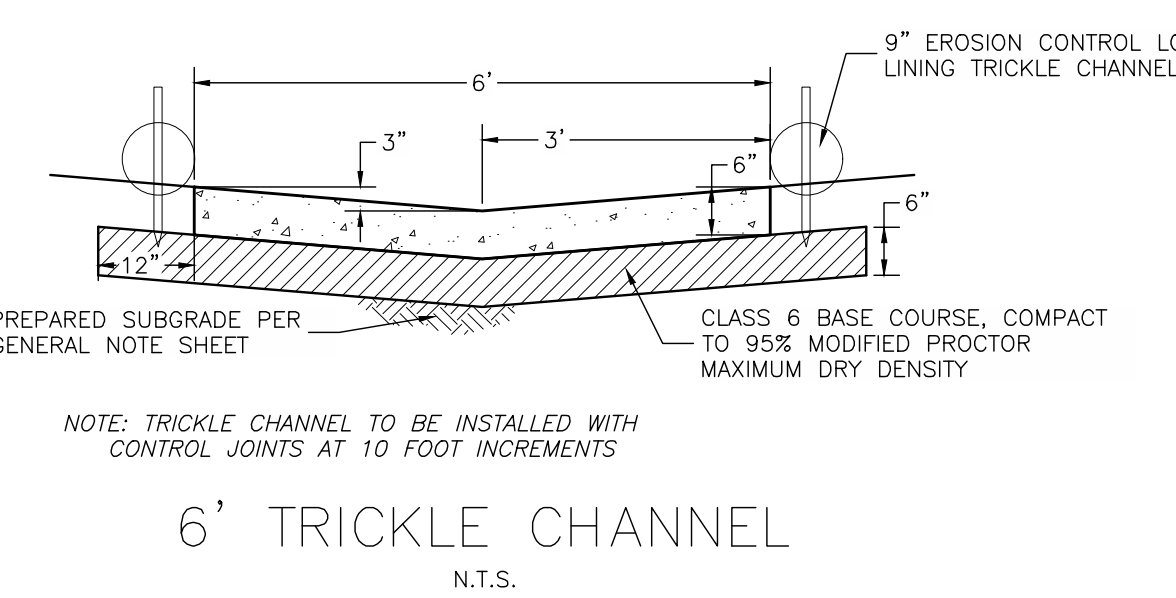
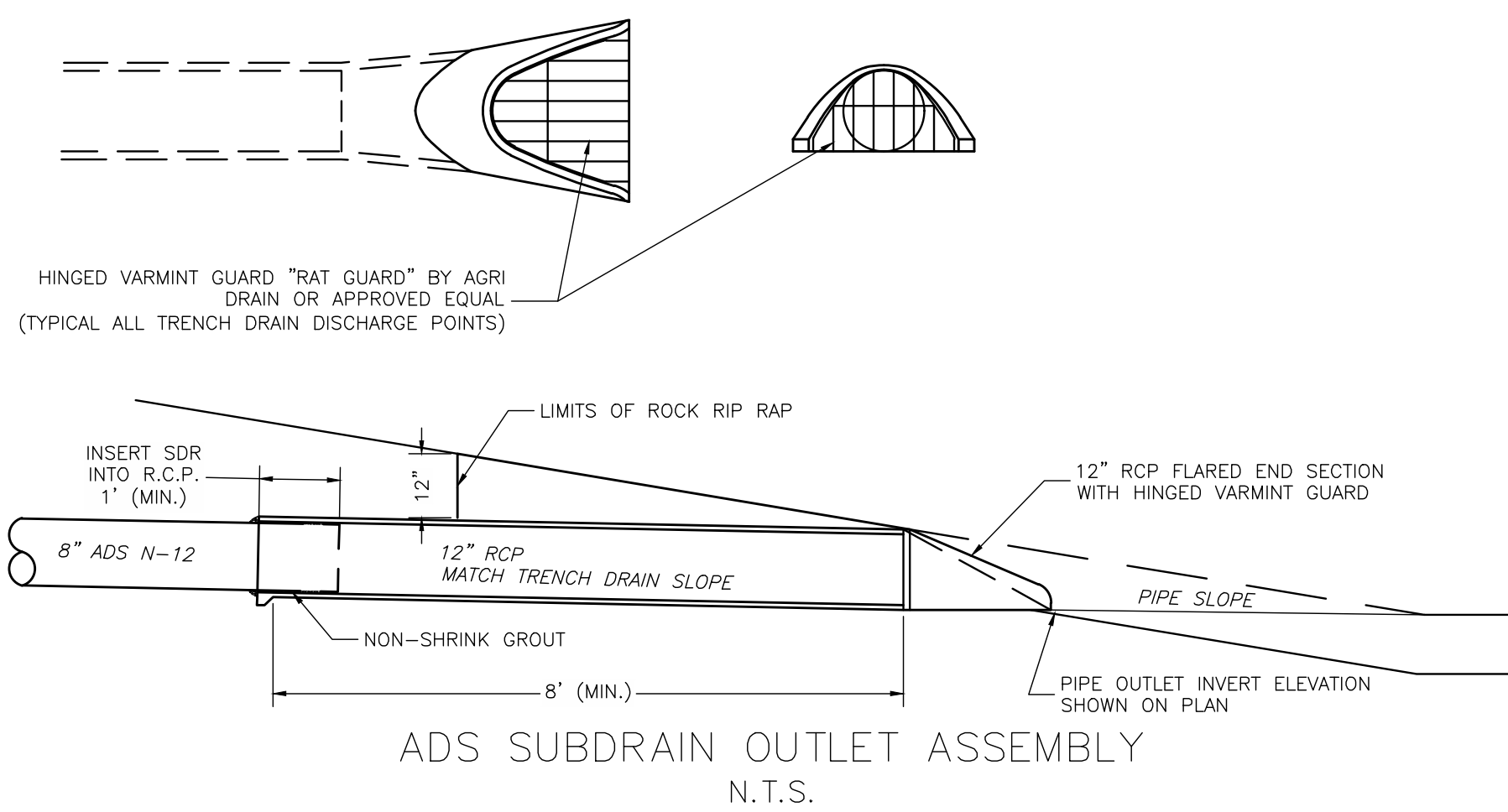
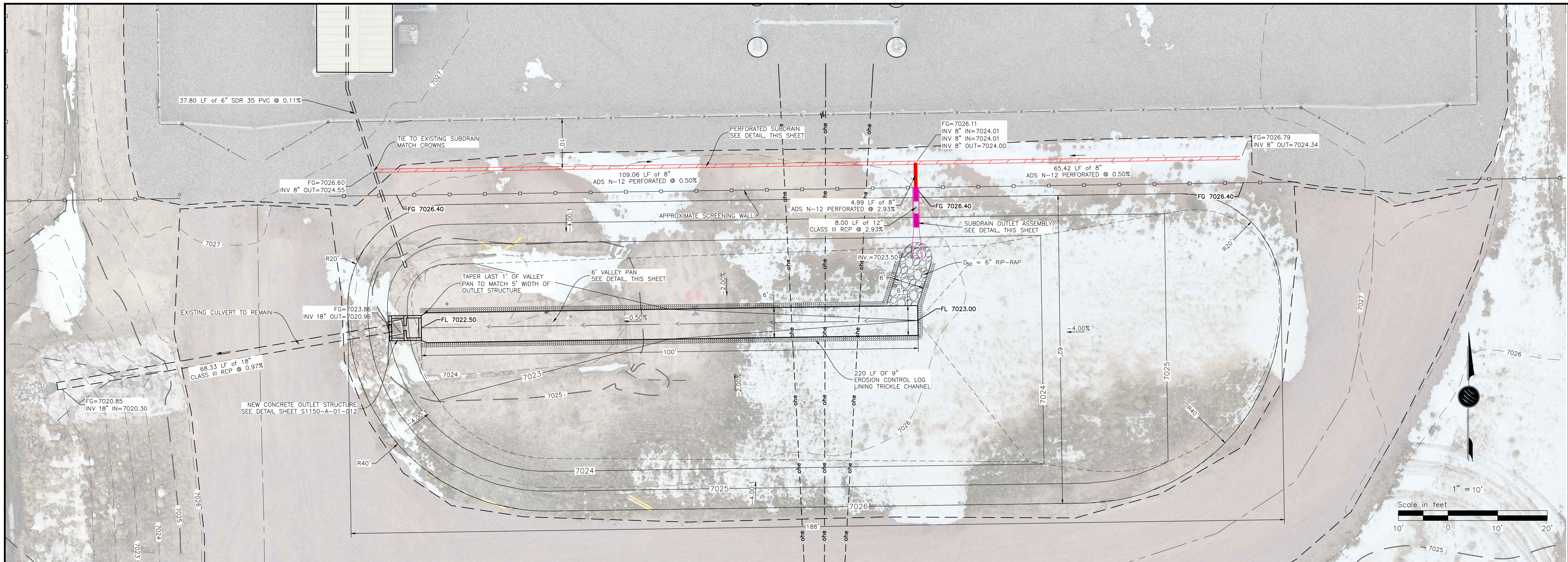

- PIPE, AGGREGATE, & FABRIC INSTALLATION NOTES:
- LAY FABRIC IN TRENCH PRIOR TO PLACEMENT OF AGGREGATE.
 - INSTALL PERFORATED PIPE TO DESIGN GRADES WITH PERFORATIONS PER DETAIL.
 - BACKFILL TO DESIGN SURFACE GRADES AND ELEVATIONS WITH 1/2" CRUSHED AGGREGATE PER SPECIFICATIONS.
 - ALL BURIED PIPE ENDS SHALL BE CAPPED

7		M.F.	
6		M.F.	
5		M.F.	
4		M.F.	
3		M.F.	
2		M.F.	
1		M.F.	
No.	Date	Dwn.	Appd.
<p>VOLLMER DRAINAGE IMPROVEMENTS</p> <p>LAYOUT, GRADING, & DRAINAGE DETAILS</p> <p>TRI-STATE GENERATION & TRANSMISSION ASSOCIATION, INCORPORATED</p> <p>115 KV</p> <p>1100 W. 116th Ave. P.O. Box 33890 Denver, Colorado 80233</p> <p>303-452-6111</p> <p>DATE: 06/19/24</p> <p>PROJECT: S1150-A-01-011</p>			

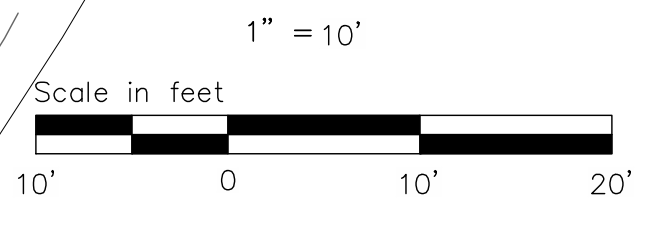
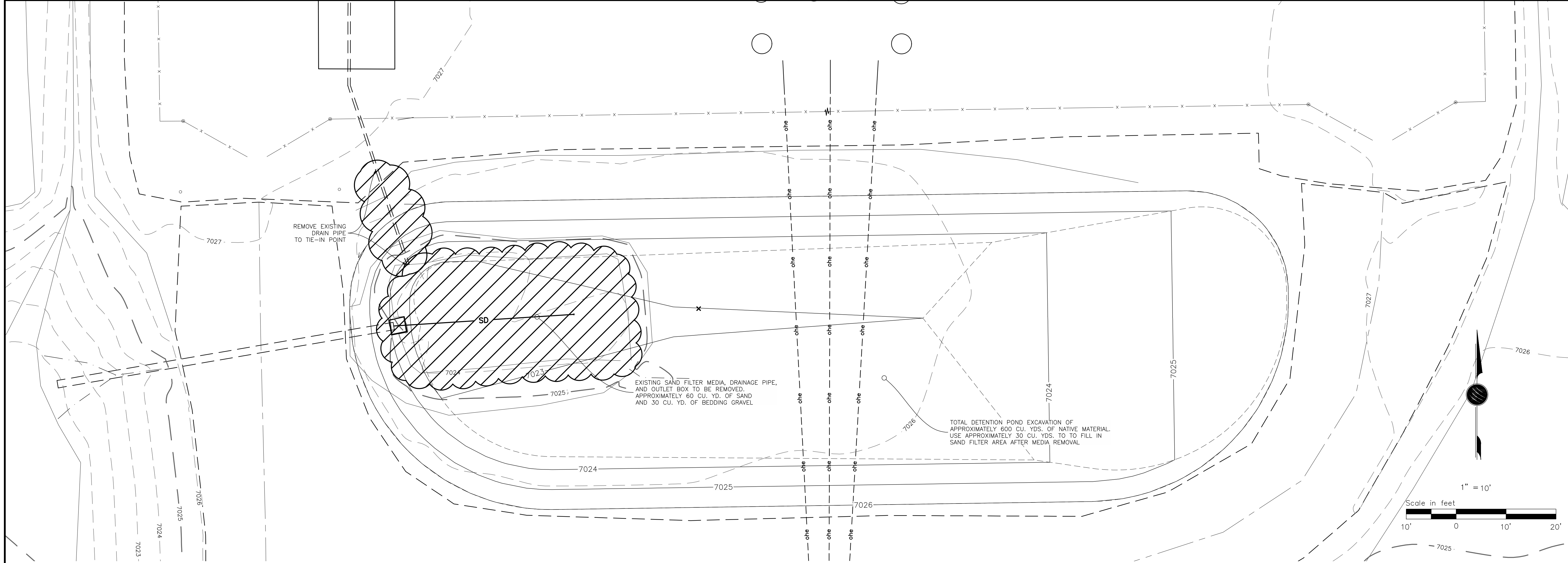

TRI-STATE Generation and Transmission Association, Inc. 1100 W. 116th Ave. P.O. Box 338905 Denver, Colorado 80233 303-452-6111		VOLLMER DRAINAGE IMPROVEMENTS 115 KV LAYOUT & GRADING TRI-STATE GENERATION & TRANSMISSION ASSOCIATION, INCORPORATED UPDATED BY: TCLEMENT 6/19/2024 6:57 AM Contract:		Dwn: TMC Date: 06/19/24 Appd: Date:	
PATH: \\DMS1\A\Projects\Active\Projects\2023\23203-Vollmer Sub Drainage BA\Facility\Civil\Media\23203C_BA5E.dwg		No. 1 Date . Dwn. . Appd. . 2 3 4 5 6 7		Revision M.F.	
		Dwg. No.		Mgr.	
		Reference Drawings		Drawing Title	

S1150-A-01-011R

