

**STORMWATER MANAGEMENT PLAN
FOR
HOMESTEAD NORTH AT STERLING RANCH
FILING NO. 2**

Prepared For (Applicant):

SR Land, LLC
20 Boulder Crescent, Suite 201
Colorado Springs, CO 80903
(719) 471-1742
Contact: James Morley

Prepared By:

JR Engineering, LLC
5475 Tech Center Drive, Suite 235
Colorado Springs, Colorado 80919
(303) 267-6240
Contact: Mike Bramlett

Qualified Stormwater Manager:

To Be Determined

Contractor:

To Be Determined

November, 2022

El Paso County PCD File No.:
SF-22-18

ENGINEER OF RECORD:

The Stormwater Management Plan was prepared under my direction and supervision and is correct to the best of my knowledge and belief. Said Plan has been prepared according to the criteria established by the County and State for Stormwater Management Plans.



Mike Bramlett, P.E.
Registered Professional Engineer
State of Colorado No. 32314
For and on behalf of JR Engineering, LLC.

Date

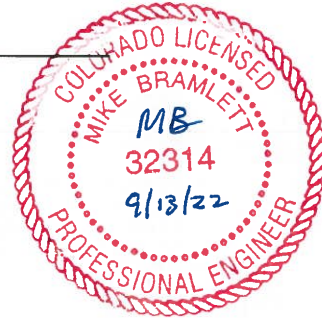

REVIEW ENGINEER:

The Stormwater Management Plan was reviewed and found to meet the checklist requirements except where otherwise noted or allowed by an approved deviation request.

Review Engineer

Date

TABLE OF CONTENTS

1.	Applicant / Contact Information	1
2.	Site Description and Location.....	1
3.	Proposed Sequence of Major Activities	4
4.	BMPs for Stormwater Pollution Prevention	4
5.	Final Stabilization and Long-Term Stormwater Management.....	7
6.	Inspection and Maintenance.....	8

Appendices

A. Vicinity Map

B. Soils Map

C. GEC Plans and Details

D. SWMP Report and GEC Plan Checklists

E. Inspection Report Template

1. Applicant / Contact Information

Owner/Developer: SR Land, LLC
Attn: James Morley
20 Boulder Crescent, Suite 201
Colorado Springs, CO 80903
(719) 471-1742

Engineer: JR Engineering, LLC
5475 Tech Center Drive, Suite 235
Colorado Springs, CO 80919
Attn: Mike Bramlett (303) 267-6240
mbramlett@jrengineering.com

SWMP Administrator: To Be Determined

Contractor: To Be Determined

2. Site Description and Location

The site is located in a portion of the southwest quarter of the southwest quarter of Section 27, the east half of Section 28, and northeast quarter of Section 33, all in Township 12 South, Range 66 West of the 6th Principal Meridian. Homestead North at Sterling Ranch Filing No. 2 is an approximately 32.6 acre, single family-development. The proposed development is comprised of 74 lots and associated infrastructure. The construction site is located to the east side of Vollmer Road, which bounds the west side of the project. Homestead North at Sterling Ranch Filing No. 1 (tax schedule number 5233102001) which is also single-family residential lots bound the south side of the site. To the north of the site is currently undeveloped land, which in the future will also be single-family residential lots. To the east of the site is the Sand Creek drainageway. The nearest street intersection of Dines Blvd. and Vollmer Rd. is located approximately 2,070 feet southwest of the southwestern corner of the site boundary. See Appendix A for a vicinity map.

The existing site is undeveloped and currently composed of nearly bare ground and some existing natural drainage paths that run in general from north to south. The development of the proposed site will include implementation of BMPs, site grading, utility and storm installation, roadway paving, associated residential site development, and removal of temporary BMPs. Refer to the GEC plans in Appendix C for the phasing of BMPs.

Site details:

- a. Estimated area to undergo disturbance: 33.6 acres
 - i. Some off-site grading is proposed along the northern property boundary.
All off-site stormwater control measures will still be under the direct

- ownership of the owner or operator.
- b. Estimated 100-year runoff coefficients:
 - i. Historic: $C = 0.35$
 - ii. Developed: $C = 0.58$
 - c. Soil Type: The site is entirely comprised of Pring coarse sandy loam, with 3 to 8 percent slopes, which is classified as a Hydrologic Group B soil by the Natural Resources Conservation Service (NRCS). Group B soils exhibit a moderate infiltration rate when thoroughly wet and consist of moderately well-drained to well-drained soils. These soils have a moderate rate of water transmission. Refer to Appendix B for a soils map. Eroded soil may adversely impact downstream drainage ways. BMP's will be installed and maintained to mitigate adverse impacts due to soil erosion.
 - d. Soil erosion potential and potential impacts upon discharge:
 - i. Conduct land-disturbing activities in a manner that effectively reduces accelerated soil erosion and reduces sediment movement and deposition off site.
 - ii. Schedule construction activities to minimize the total amount of soil exposed at any given time.
 - iii. Establish temporary or permanent cover on areas that have been disturbed as soon as practical after grading is completed.
 - iv. Design and construct temporary or permanent facilities to limit the flow of water to non-erosive velocities for the conveyance of water around, through or from the disturbed area.
 - v. Remove sediment caused by accelerated soil erosion from surface runoff water before it leaves the site.
 - vi. Stabilize disturbed areas with permanent vegetative cover and provide permanent storm water quality control measures for the post-construction condition.
 - e. Existing vegetation: Native meadow grasses (approximately 30% coverage), determined using aerial inspection.
 - f. Location and description of potential pollution sources: Potential sources of pollution include: Onsite waste management, portable toilets, onsite vehicle fueling, and outdoor storage, vehicle tracking pads, dust management, and temporary stock pile. The locations of these sources are shown in the GEC plans in Appendix C or will be determined by the contractor.
 - i. Non-industrial waste sources such as worker trash and portable toilets – Clean up litter and debris from the construction site daily and worker trash receptacles will be located by entrance/exit for easy removal/replace access. All portable toilets should be kept a minimum of 50 feet from a storm drain inlet or drainage course and secured to the ground. Toilets will be cleaned regularly and inspected daily for any spills or leaks. Waste disposal bins will be reasonably maintained at regular intervals to check for leaks and overflow capacity, and will be emptied routinely to prevent overflow.
 - ii. Routine maintenance activities involving fertilizers, pesticides, detergents, fuels, solvents, oils, etc. – oil, grease, coolants, etc. that leak onto the soil or impervious surface should be cleaned up as soon as possible and on-site

- personnel notified.
- iii. Vehicle, equipment maintenance, and fueling – all designated fueling and maintenance areas shall be located a minimum of 100 feet from any drainage course whenever possible. If the fueling area is located on a pervious surface, the area shall be covered with a non-pervious lining so as to prevent soil contamination by way of infiltration. Any spillage shall be cleaned up immediately.
 - iv. Raw materials, intermediate products, byproducts, process residuals, Finished products, containers, and materials storage areas can be sources of pollutants such as metals, oils and grease, sediment and other contaminants. Where practical, conduct operations indoors. Where impractical, select an appropriate temporary or permanent covering to reduce exposure of materials to rainfall and runoff.
 - v. Vehicle tracking controls (VTC) provide stabilized construction site access where vehicles exit the site onto paved public roads. An effective vehicle tracking control helps remove sediment (mud or dirt) from vehicles, reducing tracking onto the paved surface. With aggregate vehicle tracking controls, ensure rock and debris from this area do not enter the public right-of-way. Inspect the VTC for degradation and replace aggregate or material used for a stabilized entrance/exit as needed.
 - vi. Wind erosion and dust control BMPs help to keep soil particles from entering the air as a result of land disturbing construction activities. Dust control measures should be used on any site where dust poses a problem to air quality. Dust control is important to control for the health of construction workers and surrounding waterbodies.
 - vii. Stockpile management should be used when soils or other erodible materials are stored at the construction site. Special attention should be given to stockpiles in close proximity to natural or manmade storm systems. Soils stockpiled for an extended period (typically for more than 30 days) mulched with a temporary grass cover once the stockpile is placed (typically within 21 days). An area that will remain in an interim state for over 60 days must also be seeded. Use of mulch only or a soil binder is acceptable if the stockpile will be in place for a more limited time period (typically 30-60 days). Refer to DCM Vol 2 – Section 3.2- General principles - Basic Grading, Erosion and Stormwater Quality Requirements and General Prohibitions #16 for more information.
 - g. Spill prevention and pollution controls for dedicated batch plants: Not applicable for this site since there will be no dedicated batch plants.
 - h. Street sweeping or vacuuming should be conducted when there is noticeable sediment accumulation on roadways adjacent to the construction site. Typically, this will be concentrated at the entrance/exit to the construction site. Well-maintained stabilized construction entrances and vehicle tracking controls can help reduce the necessary frequency of street sweeping and vacuuming.
 - i. Location and description of anticipated non-stormwater components of discharge: There will be a concrete washout area (CWA) where the cleaning of concrete trucks could produce a non-stormwater discharge. Proper installation and maintenance of

the CWA will not allow runoff from this area. Another potential source of non-stormwater discharge could be the irrigation of permanent seeding (PS). Irrigation will be kept at a rate so as to not create runoff.

- j. Existing basin drainage patterns are generally from north to south and west to east by way of sheet flow.
- k. Receiving water: Runoff from the project will be treated and released through an outlet structure pipe that will direct the water into Sand Creek. The water will follow the historic path and continue flowing southwest.
- l. There are no streams that cross the project site.

3. Proposed Sequence of Major Activities

The project will follow standard construction sequences for construction, i.e., clearing and grubbing, over excavation, overlot grading, utility installation, and street paving. The contractor will be responsible for implementing and maintaining the erosion and sediment control measures described in this document and the accompanying design drawings. The contractor may designate these tasks to certain subcontractors as they see fit, but the ultimate responsibility for implementing these controls and their proposed function at each phase of the project remains with the contractor. The order of major activities (with estimated completion dates) will be as follows:

- 1. Install VTC and other perimeter soil erosion control measures (Spring 2023).
- 2. Clear and rough grade for improvements (Spring 2023).
- 3. Install rough cut street control (Summer 2023).
- 4. Place Seed and Mulch (Fall 2023).
- 5. Clean up and final stabilization (Fall 2023).

4. BMPs for Stormwater Pollution Prevention

See GEC plans in Appendix C for BMP locations and detail sheets.

a. Erosion and Sediment Controls

i. Structural BMPs:

- 1. Sediment basins (SB) to collect runoff before it enters receiving waters (initial, interim)
- 2. Silt fence (SF) along downstream limits of disturbed areas to filter sediment from runoff (initial, interim)
- 3. Stabilized staging area (SSA) near site entrance to consolidate construction equipment in a stabilized location (initial, interim)
- 4. Construction fence (CF) to identify limits of construction (LOC) where silt fence is not needed (initial, interim)
- 5. Vehicle tracking control (VTC) at site entrance to prevent sediment from leaving the site via vehicle tires (initial, interim)
- 6. Rough Cut Street Control (RCS) is material placed after a road has been cut and before base has been installed for paving (initial)
- 7. Erosion Control Blanket (ECB) is used on slopes greater than a 3:1

- slope (interim)
- 8. Temporary stock pile (TSP) to consolidate materials such as topsoil in a controlled area bounded by silt fence (interim)
- 9. Inlet protection (IP) around culvert entrances (interim, final)
- 10. Outlet protection (OP) at culvert outlets (interim, final)
- 11. Concrete washout area (CWA) to allow a controlled area for concrete trucks to be washed (initial, interim)
- 12. Temporary Swale (TSW) to Convey runoff to sediment basins (initial, interim)
- 13. Straw Bale Barrier (STB) to be used as check dams in swales to slow and filter sediment from runoff (initial, interim)
- 14. Sediment Control Logs (SCL) to slow and filter sediment from runoff, to be placed behind sidewalks (initial, interim)
- ii. Non-structural BMPs:
 - 1. Mulching (MU) to stabilize soils and promote seed growth (final)
 - 2. Permanent seeding (PS) to stabilize disturbed areas (final)
- b. Materials Handling and Spill Prevention
 - i. General Materials Handling Practices:
 - 1. Potential pollutants shall be stored and used in a manner consistent with the manufacturer's instructions in a secure location. To the extent practical, material storage areas should not be located near storm drain inlets and should be equipped with covers, roofs, or secondary containment as required to prevent storm water from contacting stored materials. Chemicals that are not compatible shall be stored in segregated areas so that spilled materials cannot combine and react.
 - 2. Disposal of materials shall be in accordance with the manufacturer's instructions and applicable local, state, and federal regulations.
 - 3. Materials no longer required for construction shall be removed from the site as soon as possible.
 - 4. Adequate garbage, construction waste, and sanitary waste handling and disposal facilities shall be provided as necessary to keep the site clear of obstruction and BMPs clear and functional.
 - ii. Specific Materials Handling Practices
 - 1. All pollutants, including waste materials and demolition debris, that occur onsite during construction shall be handled in a way that does not contaminate storm water.
 - 2. All chemicals including liquid products, petroleum products, water treatment chemicals, and wastes stored onsite shall be covered and protected from vandalism.
 - 3. Maintenance, fueling, and repair of all equipment and vehicles involving oil changes, hydraulic system drain down, degreasing operations, fuel tank drain down and removal, and other activities which may result in the accidental release of contaminants, shall be conducted under cover during wet weather and on an impervious surface to prevent release of contaminants onto the ground. Materials

spilled during maintenance operations shall be cleaned up immediately and properly disposed of.

4. Wheel wash water shall be settled and discharged onsite by infiltration.
 5. Application of agricultural chemicals, including fertilizers and pesticides, shall be conducted in a manner and at application rates that will not result in loss of chemical to storm water runoff. Follow manufacturer's recommendations for application rates and procedures.
 6. pH-modifying sources shall be managed to prevent contamination of runoff and storm water collected onsite. The most common sources of pH-modifying materials are bulk cement, cement kiln dust (CKD), fly ash, new concrete washing and curing waters, waste streams generated from concrete grinding and sawing, exposed aggregate processes, and concrete pumping and mixer washout waters.
- iii. Spill Prevention and Response Procedures
1. The primary objective in responding to a spill is to quickly contain the material(s) and prevent or minimize their migration into storm water runoff and conveyance systems. If the release has impacted onsite storm water, it is critical to contain the released materials onsite and prevent their release into receiving waters.
 2. Spill Response Procedures:
 - a. Notify site superintendent immediately when a spill, or the threat of a spill, is observed. The superintendent shall assess the situation and determine the appropriate response.
 - b. If spills represent an imminent threat of escaping onsite facilities and entering the receiving waters, site personnel shall respond immediately to contain the release and notify the superintendent after the situation has stabilized.
 - c. The site superintendent, or his/her designee, shall be responsible for completing a spill reporting form and for reporting the spill to the appropriate agency.
 - d. Spill response equipment shall be inspected and maintained as necessary to replace any materials used in spill response activities.
 3. Spill kits shall be on-hand at all fueling sites. Spill kit location(s) shall be reported to the SWMP administrator.
 4. Absorbent materials shall be on-hand at all fueling areas for use in containing inadvertent spills. Containers shall be on-hand at all fueling sites for disposal of used absorbents.
 5. Recommended components of spill kits include the following:
 - a. Oil absorbent pads (one bale)
 - b. Oil absorbent booms (40 feet)
 - c. 55-gallon drums (2)
 - d. 9-mil plastic bags (10)
 - e. Personal protective equipment including gloves and goggles

6. Concrete wash water: unless confined in a pre-defined, bermed containment area, the cleaning of concrete truck delivery chutes is prohibited at the job site.
7. Notification procedures:
 - a. In the event of an accident or spill, the SWMP administrator shall be notified.
 - b. Depending on the nature of the spill material involved, the Colorado Department of Public Health and Environment (24-hour spill reporting line: 887-518-5608), downstream water users, or other agencies may also need to be notified.
 - c. Any spill of oil which 1) violates water quality standards, 2) produces a “sheen” on a surface water, or 3) causes a sludge or emulsion, or any hazardous substance release, or hazardous waste release which exceeds the reportable quantity, must be reported immediately by telephone to the National Response Center Hotline at (800) 424-8802.

5. Final Stabilization and Long-Term Stormwater Management

- a. Permanent seeding will be provided to achieve long-term stabilization of the site.
- b. Seed Mix: Sand dropseed, or approved equal.
- c. Seeding Application Rate: Drill seed 0.25” to 0.5” into the soil. In small areas not accessible to a drill, hand broadcast at double the rate and rake 0.25” to 0.5” into the soil. Apply seed at the following rates:
 - i. Dryland: 20-25 lbs/acre
 - ii. Irrigated: 40 lbs/acre
- d. Soil stabilization Practices:
 - i. Mulching Application: Apply 1-1/2 tons of certified weed free hay per acre mechanically crimped into the soil in combination with an organic mulch tackifier. On slopes and ditches requiring a blanket, the blanket shall be placed in lieu of much and mulch tackifier.
- e. Soil Conditioning and Fertilization Requirements:
 - i. Soil conditioner, organic amendment shall be applied to all seeded areas at 3 CY / 1000 SF.
 - ii. Fertilizer shall consist of 90% fungal biomass (mycelium) and 10% potassium-magnesia with a grade of 6-1-3 or approved equal. Fertilizer shall be applied as recommended by seed supplier.
- f. Final stabilization is reached when all soil-disturbing activities at the site have been completed, and uniform vegetative cover has been established with an individual plant density of at least 70 percent of pre-disturbance levels, or equivalent permanent, physical erosion reduction methods have been employed.
 - i. The overall project does not solely rely on another entity or control measures for final stabilization or permanent water quality or detention.
- g. Final Stabilization and Long-term Stormwater Quality:
 - i. After final stabilization occurs, Stormwater Quality of the site will be maintained via the use of full-spectrum ponds, all developed flows on site

will be routed to the pond and treated.

1. Mowing and Trimming shall occur on a regular basis in the pond and at the spillway.
- ii. Onsite flows will also be treated via grass swales that route flows present in open spaces to the storm sewer system which eventually outfalls to the full-spectrum pond.

6. Inspection and Maintenance

a. Inspection Schedules:

- i. The contractor shall inspect BMPs once every 14 days at a minimum, and immediately (within 24 hours) after any precipitation or snowmelt event that causes surface erosion (i.e. that results in storm water running across the ground), to ensure that BMPs are maintained in effective operating condition.
- ii. The contractor will be responsible for any re-excavation of sediment and debris that collects in the basin depression required to ensure that the basin meets the design grades following construction. The storm lines shall also be cleaned and free of sediment once the site becomes stabilized.

b. Inspection Procedures:

i. Site Inspection / Observation Items:

1. Construction site perimeter and discharge points
2. All disturbed areas
3. Areas used for material / waste storage that are exposed to precipitation
4. Other areas having a significant potential for storm water pollution, such as demolition areas or concrete washout areas, or locations where vehicles enter or leave the site
5. Erosion and sediment control measures identified in the SWMP
6. Any other structural BMPs that may require maintenance, such as secondary containment around fuel tanks, or the conditions of spill response kits.

ii. Inspection Requirements:

1. Determine if there is any evidence of, or potential for, pollutants entering the receiving waters.
2. Review BMPs to determine if they still meet design and operational criteria in the SWMP, and if they continue to adequately control pollutants at the site.
3. Upgrade and/or revise any BMPs not operating in accordance with the SWMP and update the SWMP to reflect any revisions.
4. The SWMP should be viewed as a “living document” that is continuously being reviewed and modified as a part of the overall process of evaluating and managing storm water quality issues at the site.
5. The QSM will be sufficiently qualified for the required duties per

the ECM Appendix I.5.2.A.

6. The Qualified Storm water Manager shall amend the SWMP when there is a change in design, construction, operation or maintenance of the site which would require the implementation of new or revised BMPs or if the SWMP proves to be ineffective in achieving the general objectives of controlling pollutants in storm water discharges associated with construction activity or when BMPs are no longer necessary and are removed.
- iii. BMP Maintenance / Replacement and Failed BMPs:
1. The contractor shall remove sediment that has been collected by perimeter controls, such as silt fence and inlet protection, on a regular basis to prevent failure of BMPs, and remove potential of sediment from being discharged from the site in the event of BMP failure.
 2. Removed sediment must be moved to an appropriate location where it will not become an additional pollutant source, and should never be placed in ditches or streams.
 3. The contractor shall update the GEC as required with any new BMPs added during the construction period.
 4. The SWMP should be viewed as a “living document” that is continuously being reviewed and modified as a part of the overall process of evaluating and managing storm water quality issues at the site.
 5. The Qualified Storm water Manager shall amend the SWMP when there is a change in design, construction, operation or maintenance of the site which would require the implementation of new or revised BMPs or if the SWMP proves to be ineffective in achieving the general objectives of controlling pollutants in storm water discharges associated with construction activity or when BMPs are no longer necessary and are removed.
 6. The contractor shall address BMPs that have failed or have the potential to fail without maintenance or modifications, as soon as possible, immediately in most cases, to prevent discharge of pollutants.
- iv. Record Keeping and Documenting Inspections:
1. The contractor shall maintain records of all inspection reports, including signed inspection logs, at the project site.
 2. The permittee shall document inspection results and maintain a record of the results for a period of 3 years following expiration or inactivation of permit coverage.
 3. Site inspection records shall include the following:
 - a. Inspection date
 - b. Name and title of personnel making the inspection
 - c. Location of discharges of sediment or other pollutants from the site
 - d. Location(s) of BMPs in need of maintenance

- e. Location(s) of BMPs that failed to operate as designed or proved inadequate for a particular location
- f. Location(s) where additional BMPs are needed that were not in place at the time of inspection
- g. Deviations from the minimum inspection schedule

APPENDIX A – VICINITY MAP

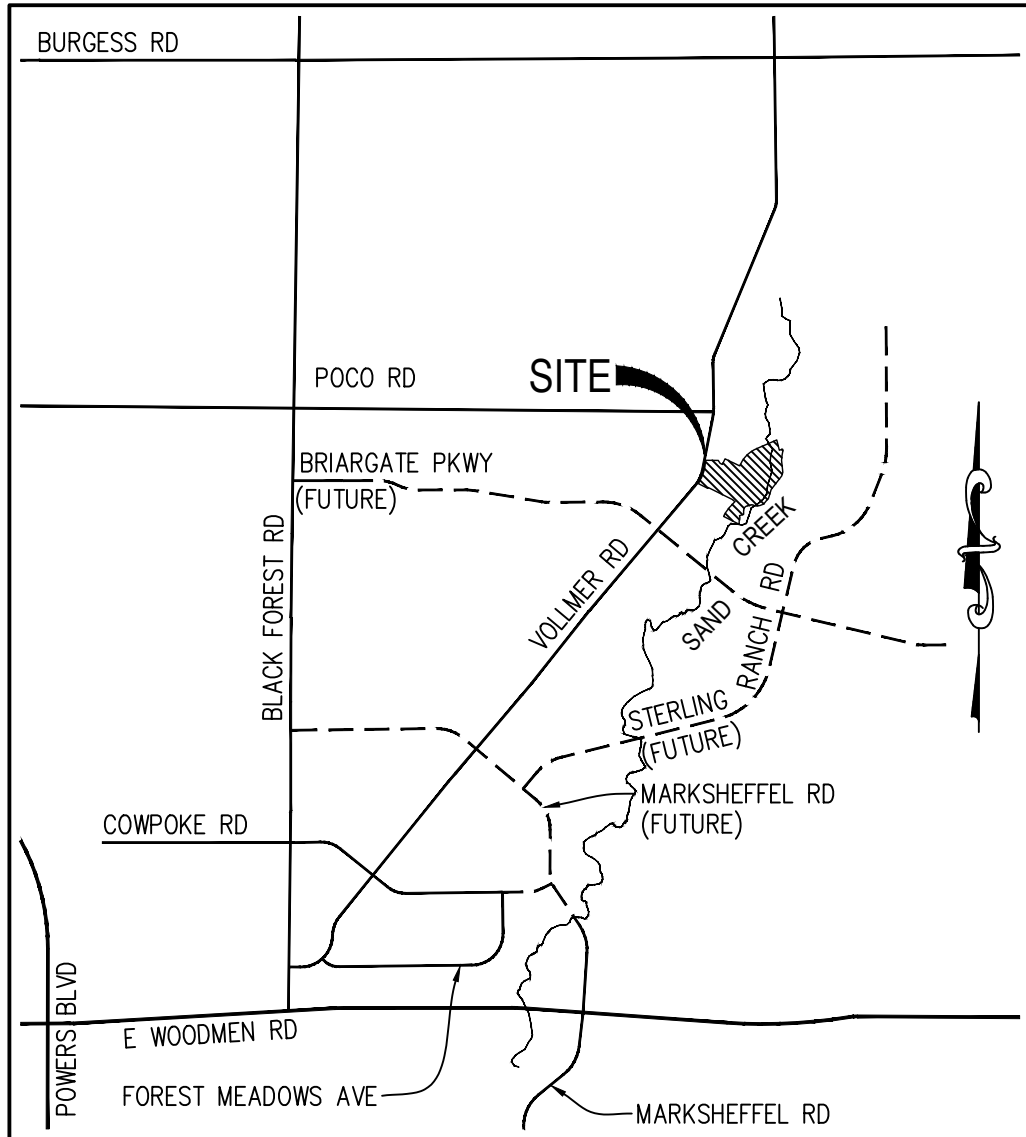

VICINITY MAP

N.T.S.

VICINITY MAP
 HOMESTEAD NORTH FIL. 1
 JOB NO. 25188.10
 1/11/22
 SHEET 1 OF 1



J·R ENGINEERING

A Westrian Company







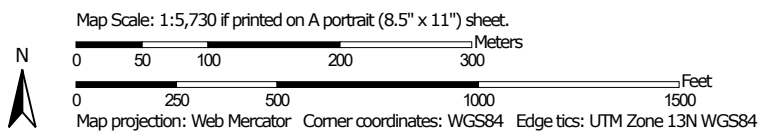
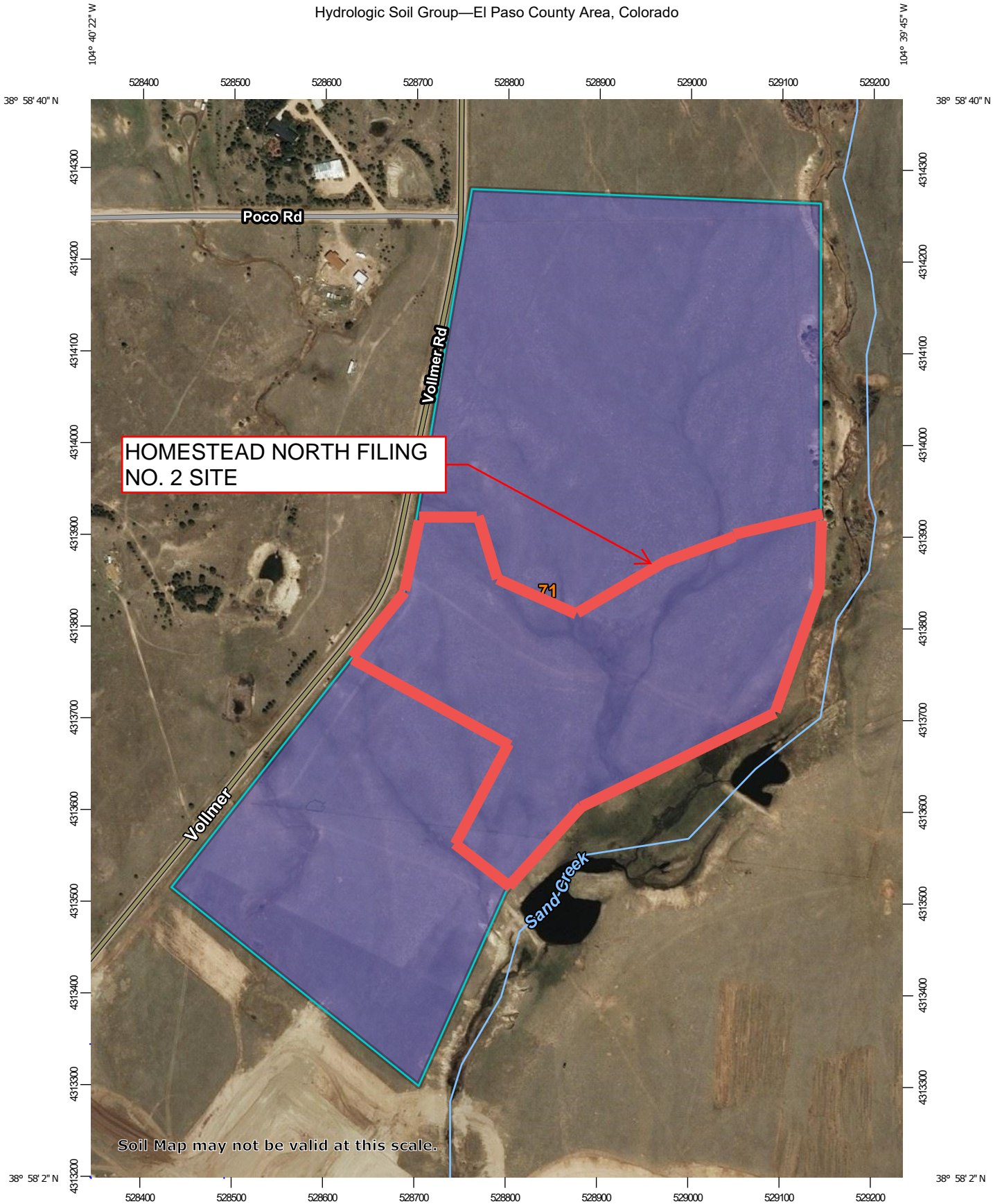

























Centennial 303-740-9393 • Colorado Springs 719-593-2593
 Fort Collins 970-491-9888 • www.jrengineering.com

APPENDIX B – SOILS MAP

Hydrologic Soil Group—El Paso County Area, Colorado



MAP LEGEND

- Area of Interest (AOI)**
 -  Area of Interest (AOI)
- Soils**
 - Soil Rating Polygons**
 -  A
 -  A/D
 -  B
 -  B/D
 -  C
 -  C/D
 -  D
 -  Not rated or not available
 - Soil Rating Lines**
 -  A
 -  A/D
 -  B
 -  B/D
 -  C
 -  C/D
 -  D
 -  Not rated or not available
 - Soil Rating Points**
 -  A
 -  A/D
 -  B
 -  B/D
-  C
-  C/D
-  D
-  Not rated or not available
- Water Features**
 -  Streams and Canals
- Transportation**
 -  Rails
 -  Interstate Highways
 -  US Routes
 -  Major Roads
 -  Local Roads
- Background**
 -  Aerial Photography

MAP INFORMATION

The soil surveys that comprise your AOI were mapped at 1:24,000.

Warning: Soil Map may not be valid at this scale.
 Enlargement of maps beyond the scale of mapping can cause misunderstanding of the detail of mapping and accuracy of soil line placement. The maps do not show the small areas of contrasting soils that could have been shown at a more detailed scale.

Please rely on the bar scale on each map sheet for map measurements.

Source of Map: Natural Resources Conservation Service
 Web Soil Survey URL:
 Coordinate System: Web Mercator (EPSG:3857)

Maps from the Web Soil Survey are based on the Web Mercator projection, which preserves direction and shape but distorts distance and area. A projection that preserves area, such as the Albers equal-area conic projection, should be used if more accurate calculations of distance or area are required.

This product is generated from the USDA-NRCS certified data as of the version date(s) listed below.

Soil Survey Area: El Paso County Area, Colorado
 Survey Area Data: Version 17, Sep 13, 2019

Soil map units are labeled (as space allows) for map scales 1:50,000 or larger.

Date(s) aerial images were photographed: Sep 8, 2018—May 26, 2019

The orthophoto or other base map on which the soil lines were compiled and digitized probably differs from the background imagery displayed on these maps. As a result, some minor shifting of map unit boundaries may be evident.

Hydrologic Soil Group

Map unit symbol	Map unit name	Rating	Acres in AOI	Percent of AOI
71	Pring coarse sandy loam, 3 to 8 percent slopes	B	90.2	100.0%
Totals for Area of Interest			90.2	100.0%

Description

Hydrologic soil groups are based on estimates of runoff potential. Soils are assigned to one of four groups according to the rate of water infiltration when the soils are not protected by vegetation, are thoroughly wet, and receive precipitation from long-duration storms.

The soils in the United States are assigned to four groups (A, B, C, and D) and three dual classes (A/D, B/D, and C/D). The groups are defined as follows:

Group A. Soils having a high infiltration rate (low runoff potential) when thoroughly wet. These consist mainly of deep, well drained to excessively drained sands or gravelly sands. These soils have a high rate of water transmission.

Group B. Soils having a moderate infiltration rate when thoroughly wet. These consist chiefly of moderately deep or deep, moderately well drained or well drained soils that have moderately fine texture to moderately coarse texture. These soils have a moderate rate of water transmission.

Group C. Soils having a slow infiltration rate when thoroughly wet. These consist chiefly of soils having a layer that impedes the downward movement of water or soils of moderately fine texture or fine texture. These soils have a slow rate of water transmission.

Group D. Soils having a very slow infiltration rate (high runoff potential) when thoroughly wet. These consist chiefly of clays that have a high shrink-swell potential, soils that have a high water table, soils that have a claypan or clay layer at or near the surface, and soils that are shallow over nearly impervious material. These soils have a very slow rate of water transmission.

If a soil is assigned to a dual hydrologic group (A/D, B/D, or C/D), the first letter is for drained areas and the second is for undrained areas. Only the soils that in their natural condition are in group D are assigned to dual classes.

Rating Options

Aggregation Method: Dominant Condition

Component Percent Cutoff: None Specified

Tie-break Rule: Higher

APPENDIX C – GEC PLANS AND DETAILS

HOMESTEAD NORTH AT STERLING RANCH FILING 2

A PORTION OF THE SW1/4 OF THE SW1/4 OF SECTION 27, THE E1/2 OF SECTION 28 AND NE1/4 OF SECTION 33,
ALL IN TOWNSHIP 12 SOUTH, RANGE 65 WEST OF THE 6TH PRINCIPAL MERIDIAN
CITY OF COLORADO SPRINGS, COUNTY OF EL PASO, STATE OF COLORADO

GRADING AND EROSION CONTROL PLAN



Know what's below.
Call before you dig.

UNTIL SUCH TIME AS THESE DRAWINGS ARE APPROVED BY THE APPROPRIATE REVIEWING AGENCIES, OR ENGINEERING APPROVES THEIR USE, THESE DRAWINGS ARE DESIGNATED BY WRITTEN AUTHORIZATION.

PREPARED FOR
SR LAND, LLC
20 BOULDER CRESCENT
SUITE 200
COLORADO SPRINGS, CO 80903
JAMES F. MORLEY
(719) 471-1742



J.R. ENGINEERING
A Westman Company
Central 303-740-9888 • Colorado Springs 719-588-2583
Fort Collins 970-491-9888 • www.jrengineering.com

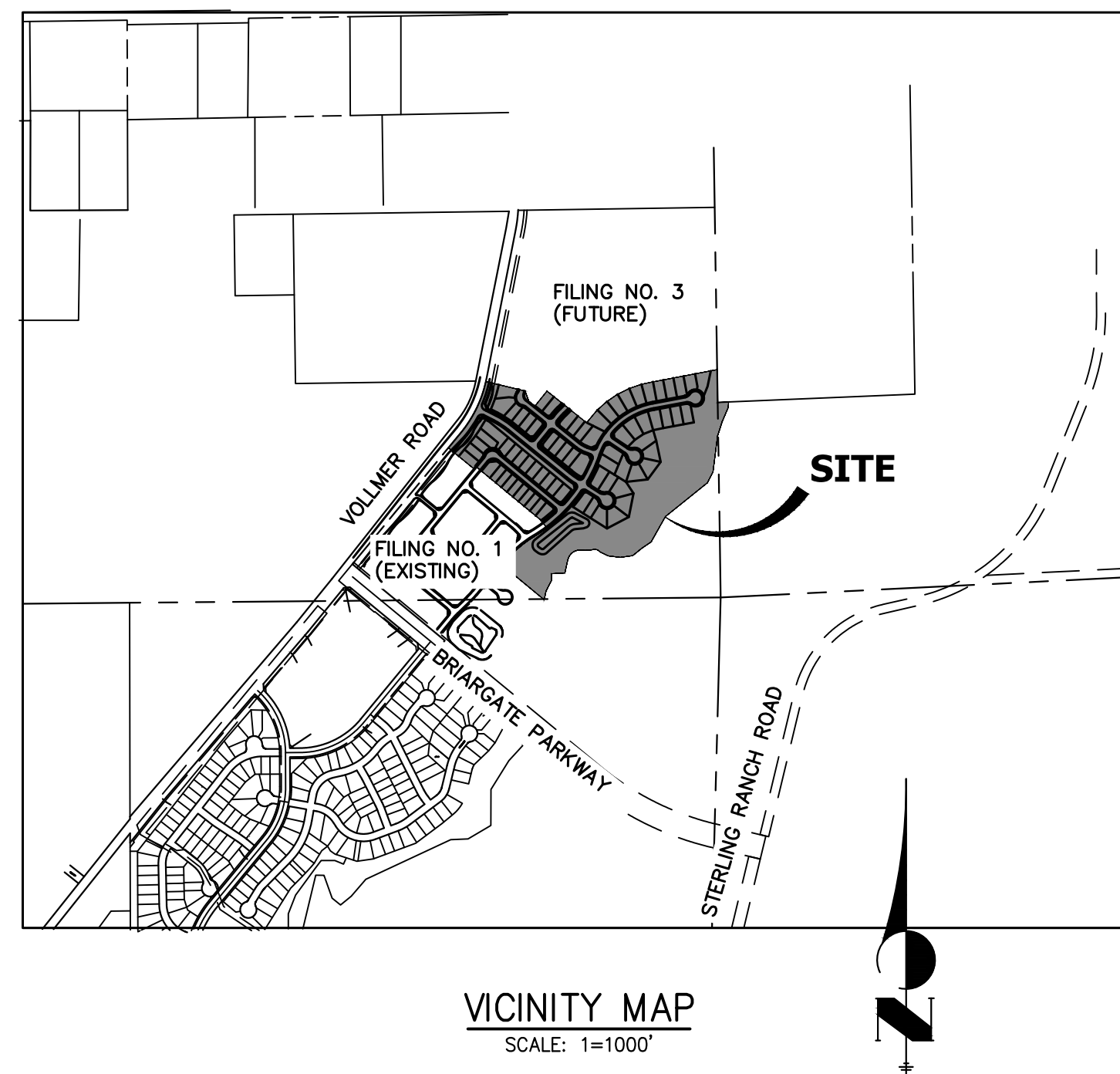

SHEET INDEX:

COVER SHEET	1
LEGEND	2
TYPICAL SECTIONS & NOTES	3
GEC-INITIAL	4-6
GEC-INTERIM	7-9
GEC-FINAL	10-12
DETAILS	13-16
TOTAL SHEETS	16

BASIS OF BEARINGS

THE SOUTH LINE OF THE SOUTHWEST QUARTER OF SECTION 34, TOWNSHIP 12 SOUTH, RANGE 65 WEST OF THE 6TH P.M. AS MONUMENTED AT THE SOUTHWEST CORNER OF SAID SOUTHWEST QUARTER BY A 2-1/2" ALUMINUM CAP STAMPED "LS 11624" AND AT THE SOUTHEAST CORNER OF SAID SOUTHWEST QUARTER BY A 2-1/2" ALUMINUM CAP STAMPED "LS 11624", SAID LINE BEARS N89°14'14"E A DISTANCE OF 2,722.69 FEET.

BENCHMARKS

- THE TOP OF AN ALUMINUM SURVEYORS CAP, STAMPED "9853", AT THE SOUTHEAST BOUNDARY CORNER OF BARBARICK SUBDIVISION
NORTHING = 411416.273
EASTING = 235167.071
ELEVATION = 7023.42
- THE TOP OF A RED PLASTIC SURVEYORS CAP, ILLEGIBLE, AT THE NORTHWEST BOUNDARY CORNER OF PAWNEE RANCHEROS SUBDIVISION
NORTHING = 410095.404
EASTING = 235052.131
ELEVATION = 7000.40
- THE TOP OF A RED PLASTIC SURVEYORS CAP, STAMPED "38141", AT THE SOUTHWEST BOUNDARY CORNER OF BARBARICK SUBDIVISION
NORTHING = 411399.962
EASTING = 233849.817
ELEVATION = 7030.82

PCD FILING NO.: SF2218

AGENCIES

OWNER/DEVELOPER	SR LAND, LLC 20 BOULDER CRESCENT, SUITE 201 COLORADO SPRINGS, CO 80903 JAMES F. MORLEY (719) 471-1742
CIVIL ENGINEER	JR ENGINEERING, LLC 5475 TECH CENTER DR. #235 COLORADO SPRINGS, CO 80919 MIKE BRAMLETT P.E. (303) 267-6240
COUNTY ENGINEERING	EL PASO COUNTY PLANNING AND COMMUNITY DEVELOPMENT COLORADO SPRINGS, 80910 CHARLENE DURHAM, P.E. (719) 520-7951
TRAFFIC ENGINEERING	EL PASO COUNTY DEPARTMENT OF PUBLIC WORKS 3275 AKERS DRIVE COLORADO SPRINGS, CO 80922 JOSHUA PALMER, P.E. (719) 520-6460
WATER RESOURCES	STERLING RANCH METRO DISTRICT ENGINEERS JDS-HYDRO CONSULTANTS 545 E. PIKES PEAK AVE., SUITE 300 COLORADO SPRINGS, CO 80903 JOHN MCGINN (719) 668-8769
FIRE DISTRICT	BLACK FOREST FIRE PROTECTION DISTRICT 11445 TEACHOUT ROAD COLORADO SPRINGS, CO 80908 CHIEF BRYAN JACK (719) 495-4300
GAS DEPARTMENT	COLORADO SPRINGS UTILITIES 7710 DURANT DR. COLORADO SPRINGS, CO 80947 TIM WENDT (719) 668-3556
ELECTRIC DEPARTMENT	MOUNTAIN VIEW ELECTRIC 11140 E. WOODMEN ROAD FALCON, CO 80831 (719) 495-2283

EL PASO COUNTY STATEMENT

COUNTY PLAN REVIEW IS PROVIDED ONLY FOR GENERAL CONFORMANCE WITH COUNTY DESIGN CRITERIA. THE COUNTY IS NOT RESPONSIBLE FOR THE ACCURACY AND ADEQUACY OF THE DESIGN, DIMENSIONS, AND/OR ELEVATIONS WHICH SHALL BE CONFIRMED AT THE JOB SITE. THE COUNTY THROUGH THE APPROVAL OF THIS DOCUMENT ASSUMES NO RESPONSIBILITY FOR COMPLETENESS AND/OR ACCURACY OF THIS DOCUMENT.

FILED IN ACCORDANCE WITH THE REQUIREMENTS OF THE EL PASO COUNTY LAND DEVELOPMENT CODE, DRAINAGE CRITERIA MANUAL, VOLUMES 1 AND 2, AND ENGINEERING CRITERIA MANUAL AS AMENDED.

IN ACCORDANCE WITH ECM SECTION 1.12, THESE CONSTRUCTION DOCUMENTS WILL BE VALID FOR CONSTRUCTION FOR A PERIOD OF 2 YEARS FROM THE DATE SIGNED BY THE EL PASO COUNTY ENGINEER. IF CONSTRUCTION HAS NOT STARTED WITHIN THOSE 2 YEARS, THE PLANS WILL NEED TO BE RESUBMITTED FOR APPROVAL, INCLUDING PAYMENT OF REVIEW FEES AT THE PLANNING AND COMMUNITY DEVELOPMENT DIRECTORS DISCRETION.

JOSHUA PALMER, P.E. _____ DATE _____
COUNTY ENGINEER/ECM ADMINISTRATOR

ENGINEER'S STATEMENT

THIS GRADING AND EROSION CONTROL PLAN WAS PREPARED UNDER MY DIRECTION AND SUPERVISION AND IS CORRECT TO THE BEST OF MY KNOWLEDGE AND BELIEF. SAID PLAN HAS BEEN PREPARED ACCORDING TO THE CRITERIA ESTABLISHED BY THE COUNTY FOR GRADING AND EROSION CONTROL PLANS. I ACCEPT RESPONSIBILITY FOR ANY LIABILITY CAUSED BY ANY NEGLIGENT ACTS, ERRORS OR OMISSIONS ON MY PART IN PREPARING THIS PLANS.

MIKE A. BRAMLETT, P.E. _____ DATE _____
FOR AND ON BEHALF OF JR ENGINEERING

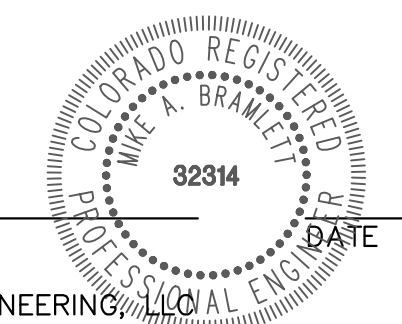

THE LOCATIONS OF EXISTING ABOVE GROUND AND UNDERGROUND UTILITIES ARE SHOWN IN AN APPROXIMATE WAY ONLY. THE CONTRACTOR SHALL DETERMINE THE EXACT LOCATION OF ALL EXISTING UTILITIES BEFORE COMMENCING WORK. THE CONTRACTOR SHALL BE FULLY RESPONSIBLE FOR ANY AND ALL DAMAGES WHICH MIGHT BE CAUSED BY HIS FAILURE TO EXACTLY LOCATE AND PRESERVE ANY AND ALL ABOVE GROUND AND UNDERGROUND UTILITIES.

H-SCALE	V-SCALE	DATE	DESIGNED BY	DRAWN BY	CHECKED BY	REVISION	
						No.	DATE
1"=1000'	N/A	11/10/22	GAG	GAG			

**HOMESTEAD NORTH AT
STERLING RANCH FILING 2
COVER SHEET**

SHEET 1 OF 16
JOB NO. 25188.10

X:\25188.10\Drawings\Sheet\Eng\GEC\25188.10_CV01.dwg, Cover: 11/9/2022 3:52:26 PM, CS

LEGEND

	KEY	SYMBOL
CHECK DAM (INTERIM/ FINAL)		
CONCRETE WASHOUT AREA (INITIAL)		
DIVERSION DITCH AND DIKE, TEMPORARY (INTERIM/ FINAL)		
DIVERSION CHANNEL, TEMPORARY (INTERIM/ FINAL)		
EROSION CONTROL BLANKET (FINAL)		
INLET PROTECTION (INITIAL/ INTERIM)		
LIMITS OF CONSTRUCTION/DISTURBANCE		
OUTLET PROTECTION (INITIAL/ INTERIM)		
PERMENT SEEDING (FINAL)		
FLOW ARROW		
SEDIMENT CONTROL LOG (INITIAL/ INTERIM)		
CUT/FILL MARK		
SILT FENCE (INITIAL)		
CONSTRUCTION FENCE		
STABILIZED STAGING AREA (INITIAL)		
TEMPORARY SEEDING & MULCHING (FINAL)		
VEHICLE TRACKING CONTROL (INITIAL)		
SEDIMENT BASIN (INITIAL)		
TEMP. STOCK PILE (INITIAL)		
TEMP. SLOPE DRAIN (INITIAL)		

LAYER LINETYPE LEGEND

	EXISTING	PROPOSED
PHASE LINE		
MATCH LINE		
SECTION LINE		
BOUNDARY LINE		
PROPERTY LINE		
EASEMENT LINE		
RIGHT OF WAY		
R.O.W. A LINE		
CENTERLINE		
CITY LIMITS		
WIRE FENCE		
CHAIN LINK FENCE		
WOOD FENCE		
MASONRY FENCE		
GUARDRAIL		
CONC. BARRIER		
CABLE TV		
ELECTRIC		
FIBER OPTIC		
GAS MAIN		
IRRIGATION MAIN		
OIL/PETRO. MAIN		
OVERHEAD UTILITY		
SANITARY SEWER		
STORM DRAIN		
TELEPHONE		
WATER MAIN		
RAW WATER LINE		
SWALE/WATERWAY FLOWLINE		
DIVERSION DITCH		
DIVERSION CHANNEL		
MAJOR DRAINAGE BASIN		
MINOR DRAINAGE BASIN		
TOP OF SLOPE		
TOE OF SLOPE		
EDGE OF WATER		
INDEX CONTOUR		
INTERMEDIATE CONTOUR		
DEPRESSION CONT. (INDEX)		
DEPRESSION CONT. (INTER)		
TOP OF CUTS		
TOE OF FILLS		
CUT AND FILL LINE		
SILT FENCE		
100 YEAR FLOODPLAIN		
500 YEAR FLOODPLAIN		
FLOODWAY		
BASE FLOOD ELEVATION		
EDGE OF WETLANDS		
STONE WALL		

UTILITIES LEGEND

	EXISTING	PROPOSED
STORM SEWER		
MANHOLE		
STORM INLET		
AREA INLET - SQUARE		
AREA INLET - ROUND		
FLARED END SECTION		
RIPRAP		
SANITARY SEWER		
LINE MARKER		
SERVICE MARKER		
CLEAN-OUT		
MANHOLE W/ DIRECTIONAL FLOW ARROW		
WATER LINE		
LINE MARKER		
SERVICE MARKER		
FIRE HYDRANT		
FIRE CONNECTION		
MANHOLE		
BEND		
BLOW-OFF VALVE		
WELL		
METER		
VALVE		
REDUCER		
THRUST BLOCK		
CROSS		
PLUG W/ THRUST BLOCK		
TEE		
REVERSE ANCHOR		
ANODE		
AIR & VACUUM VALVE ASSEMBLY		
TRANSMISSION BLOW-OFF ASSEMBLY		
GAS LINE		
MARKER		
SERVICE MARKER		
METER		
VALVE		
PLUG		
TEE		
DRY UTILITIES		
CABLE TV MARKER		
CABLE TELEVISION PEDESTAL		
ELECTRIC MARKER		
ELECTRIC SERVICE MARKER		
ELECTRICAL PEDESTAL		
ELECTRICAL METER		
ELECTRICAL MANHOLE		
FIBER-OPTIC MARKER		
IRRIGATION PEDESTAL		
TELEPHONE MARKER		
TELEPHONE PEDESTAL		
TELEPHONE MANHOLE		
UTILITY POLE		
GUY ANCHOR		
GUY POLE		
MISC. UTILITIES		
VENT PIPE		
TEST HOLE DESIGNATOR		

UNTIL SUCH TIME AS THESE DRAWINGS ARE APPROVED BY THE AGENCIES, JR ENGINEERING APPROVES THEIR USE. DESIGNS ARE DESIGNATED BY WRITTEN AUTHORIZATION.

PREPARED FOR
SR LAND, LLC
 20 BOULDER CRESCENT
 SUITE 200
 COLORADO SPRINGS, CO 80903
 JAMES F. MORLEY
 (719) 471-1742

J.R. ENGINEERING
 A Westman Company
 Centennial 303-740-9888 • Colorado Springs 719-583-2593
 Fort Collins 970-491-9888 • www.jr-engineering.com

BY	DATE	No.	REVISION

H-SCALE	V-SCALE	DATE	DESIGNED BY	DRAWN BY	CHECKED BY
N/A	N/A	11/10/22	N/A	N/A	N/A

HOMESTEAD NORTH AT STERLING RANCH FILING 2
LEGEND

SHEET 2 OF 16
 JOB NO. 25188.10



Know what's below.
 Call before you dig.

ENGINEER'S STATEMENT

STANDARD DETAILS SHOWN WERE REVIEWED ONLY FOR APPLICATION ON THIS PROJECT

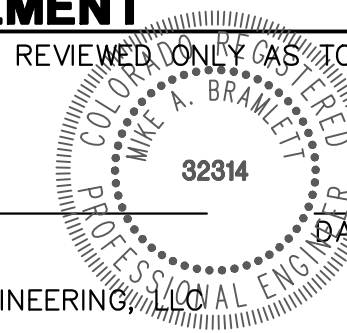

MIKE A. BRAMLETT, P.E.
 COLORADO P.E. 32314

FOR AND ON BEHALF OF JR ENGINEERING

X:\25188.10\Drawings\Sheet\Drawings\25188.10_CV01.dwg Legend 1 11/10/2022 3:52:31 PM_CS

GRADING AND EROSION CONTROL STANDARD NOTES

- STORMWATER DISCHARGES FROM CONSTRUCTION SITES SHALL NOT CAUSE OR THREATEN TO CAUSE POLLUTION, CONTAMINATION, OR DEGRADATION OF STATE WATERS. ALL WORK AND EARTH DISTURBANCE SHALL BE DONE IN A MANNER THAT MINIMIZES POLLUTION OF ANY ON-SITE OR OFF-SITE WATERS, INCLUDING WETLANDS.
- NOTWITHSTANDING ANYTHING DEPICTED IN THESE PLANS IN WORDS OR GRAPHIC REPRESENTATION, ALL DESIGN AND CONSTRUCTION RELATED TO ROADS, STORM DRAINAGE AND EROSION CONTROL SHALL CONFORM TO THE STANDARDS AND REQUIREMENTS OF THE MOST RECENT VERSION OF THE RELEVANT ADOPTED EL PASO COUNTY STANDARDS, INCLUDING THE LAND DEVELOPMENT CODE, THE ENGINEERING CRITERIA MANUAL, THE DRAINAGE CRITERIA MANUAL, AND THE DRAINAGE CRITERIA MANUAL VOLUME 2. ANY DEVIATIONS FROM REGULATIONS AND STANDARDS MUST BE REQUESTED, AND APPROVED, IN WRITING.
- A SEPARATE STORMWATER MANAGEMENT PLAN (SWMP) FOR THIS PROJECT SHALL BE COMPLETED AND AN EROSION AND STORMWATER QUALITY CONTROL PERMIT (ESQCP) ISSUED PRIOR TO COMMENCING CONSTRUCTION. MANAGEMENT OF THE SWMP DURING CONSTRUCTION IS THE RESPONSIBILITY OF THE DESIGNATED QUALIFIED STORMWATER MANAGER OR CERTIFIED EROSION CONTROL INSPECTOR. THE SWMP SHALL BE LOCATED ON SITE AT ALL TIMES DURING CONSTRUCTION AND SHALL BE KEPT UP TO DATE WITH WORK PROGRESS AND CHANGES IN THE FIELD.
- ONCE THE ESQCP IS APPROVED AND A 'NOTICE TO PROCEED' HAS BEEN ISSUED, THE CONTRACTOR MAY INSTALL THE INITIAL STAGE EROSION AND SEDIMENT CONTROL MEASURES AS INDICATED ON THE APPROVED GEC. A PRECONSTRUCTION MEETING BETWEEN THE CONTRACTOR, ENGINEER, AND EL PASO COUNTY WILL BE HELD PRIOR TO ANY CONSTRUCTION. IT IS THE RESPONSIBILITY OF THE APPLICANT TO COORDINATE THE MEETING TIME AND PLACE WITH COUNTY STAFF.
- CONTROL MEASURES MUST BE INSTALLED PRIOR TO COMMENCEMENT OF ACTIVITIES THAT COULD CONTRIBUTE POLLUTANTS TO STORMWATER. CONTROL MEASURES FOR ALL SLOPES, CHANNELS, DITCHES, AND DISTURBED LAND AREAS SHALL BE INSTALLED IMMEDIATELY UPON COMPLETION OF THE DISTURBANCE.
- ALL TEMPORARY SEDIMENT AND EROSION CONTROL MEASURES SHALL BE MAINTAINED AND REMAIN IN EFFECTIVE OPERATING CONDITION UNTIL PERMANENT SOIL EROSION CONTROL MEASURES ARE IMPLEMENTED AND FINAL STABILIZATION IS ESTABLISHED. ALL PERSONS ENGAGED IN LAND DISTURBANCE ACTIVITIES SHALL ASSESS THE ADEQUACY OF CONTROL MEASURES AT THE SITE AND IDENTIFY IF CHANGES TO THOSE CONTROL MEASURES ARE NEEDED TO ENSURE THE CONTINUED EFFECTIVE PERFORMANCE OF THE CONTROL MEASURES. ALL CHANGES TO TEMPORARY SEDIMENT AND EROSION CONTROL MEASURES MUST BE INCORPORATED INTO THE STORMWATER MANAGEMENT PLAN.
- TEMPORARY STABILIZATION SHALL BE IMPLEMENTED ON DISTURBED AREAS AND STOCKPILES WHERE GROUND DISTURBING CONSTRUCTION ACTIVITY HAS PERMANENTLY CEASED OR TEMPORARILY CEASED FOR LONGER THAN 14 DAYS.
- FINAL STABILIZATION MUST BE IMPLEMENTED AT ALL APPLICABLE CONSTRUCTION SITES. FINAL STABILIZATION IS ACHIEVED WHEN ALL GROUND DISTURBING ACTIVITIES ARE COMPLETE AND ALL DISTURBED AREAS EITHER HAVE A UNIFORM VEGETATIVE COVER WITH INDIVIDUAL PLANT DENSITY OF 70 PERCENT OF PRE-DISTURBANCE LEVELS ESTABLISHED OR EQUIVALENT PERMANENT ALTERNATIVE STABILIZATION METHOD IS IMPLEMENTED. ALL TEMPORARY SEDIMENT AND EROSION CONTROL MEASURES SHALL BE REMOVED UPON FINAL STABILIZATION AND BEFORE PERMIT CLOSURE.
- ALL PERMANENT STORMWATER MANAGEMENT FACILITIES SHALL BE INSTALLED AS DESIGNED IN THE APPROVED PLANS. ANY PROPOSED CHANGES THAT AFFECT THE DESIGN OR FUNCTION OF PERMANENT STORMWATER MANAGEMENT STRUCTURES MUST BE APPROVED BY THE ECM ADMINISTRATOR PRIOR TO IMPLEMENTATION.
- EARTH DISTURBANCES SHALL BE CONDUCTED IN SUCH A MANNER SO AS TO EFFECTIVELY MINIMIZE ACCELERATED SOIL EROSION AND RESULTING SEDIMENTATION. ALL DISTURBANCES SHALL BE DESIGNED, CONSTRUCTED, AND COMPLETED SO THAT THE EXPOSED AREA OF ANY DISTURBED LAND SHALL BE LIMITED TO THE SHORTEST PRACTICAL PERIOD OF TIME. PRE-EXISTING VEGETATION SHALL BE PROTECTED AND MAINTAINED WITHIN 50 HORIZONTAL FEET OF A WATERS OF THE STATE UNLESS SHOWN TO BE INFEASIBLE AND SPECIFICALLY REQUESTED AND APPROVED.
- COMPACTION OF SOIL MUST BE PREVENTED IN AREAS DESIGNATED FOR INFILTRATION CONTROL MEASURES OR WHERE FINAL STABILIZATION WILL BE ACHIEVED BY VEGETATIVE COVER. AREAS DESIGNATED FOR INFILTRATION CONTROL MEASURES SHALL ALSO BE PROTECTED FROM SEDIMENTATION DURING CONSTRUCTION UNTIL FINAL STABILIZATION IS ACHIEVED. IF COMPACTION PREVENTION IS NOT FEASIBLE DUE TO SITE CONSTRAINTS, ALL AREAS DESIGNATED FOR INFILTRATION AND VEGETATION CONTROL MEASURES MUST BE LOOSENEED PRIOR TO INSTALLATION OF THE CONTROL MEASURE(S).
- ANY TEMPORARY OR PERMANENT FACILITY DESIGNED AND CONSTRUCTED FOR THE CONVEYANCE OF STORMWATER AROUND, THROUGH, OR FROM THE EARTH DISTURBANCE AREA SHALL BE A STABILIZED CONVEYANCE DESIGNED TO MINIMIZE EROSION AND THE DISCHARGE OF SEDIMENT OFF SITE.
- CONCRETE WASH WATER SHALL BE CONTAINED AND DISPOSED OF IN ACCORDANCE WITH THE SWMP. NO WASH WATER SHALL BE DISCHARGED TO OR ALLOWED TO ENTER STATE WATERS, INCLUDING ANY SURFACE OR SUBSURFACE STORM DRAINAGE SYSTEM OR FACILITIES. CONCRETE WASHOUTS SHALL NOT BE LOCATED IN AN AREA WHERE SHALLOW GROUNDWATER MAY BE PRESENT, OR WITHIN 50 FEET OF A SURFACE WATER BODY, CREEK OR STREAM.
- DURING DEWATERING OPERATIONS OF UNCONTAMINATED GROUND WATER MAY BE DISCHARGED ON SITE, BUT SHALL NOT LEAVE THE SITE IN THE FORM OF SURFACE RUNOFF UNLESS AN APPROVED STATE DEWATERING PERMIT IS IN PLACE.
- EROSION CONTROL BLANKETING OR OTHER PROTECTIVE COVERING SHALL BE USED ON SLOPES STEEPER THAN 3:1.
- CONTRACTOR SHALL BE RESPONSIBLE FOR THE REMOVAL OF ALL WASTES FROM THE CONSTRUCTION SITE FOR DISPOSAL IN ACCORDANCE WITH LOCAL AND STATE REGULATORY REQUIREMENTS. NO CONSTRUCTION DEBRIS, TREE SLASH, BUILDING MATERIAL WASTES OR UNUSED BUILDING MATERIALS SHALL BE BURIED, DUMPED, OR DISCHARGED AT THE SITE.
- WASTE MATERIALS SHALL NOT BE TEMPORARILY PLACED OR STORED IN THE STREET, ALLEY, OR OTHER PUBLIC WAY, UNLESS IN ACCORDANCE WITH AN APPROVED TRAFFIC CONTROL PLAN. CONTROL MEASURES MAY BE REQUIRED BY EL PASO COUNTY ENGINEERING IF DEEMED NECESSARY, BASED ON SPECIFIC CONDITIONS AND CIRCUMSTANCES.
- TRACKING OF SOILS AND CONSTRUCTION DEBRIS OFF-SITE SHALL BE MINIMIZED. MATERIALS TRACKED OFF-SITE SHALL BE CLEANED UP AND PROPERLY DISPOSED OF IMMEDIATELY.
- THE OWNER/DEVELOPER SHALL BE RESPONSIBLE FOR THE REMOVAL OF ALL CONSTRUCTION DEBRIS, DIRT, TRASH, ROCK, SEDIMENT, SOIL, AND SAND THAT MAY ACCUMULATE IN ROADS, STORM DRAINS AND OTHER DRAINAGE CONVEYANCE SYSTEMS AND STORMWATER APPURTENANCES AS A RESULT OF SITE DEVELOPMENT.
- THE QUANTITY OF MATERIALS STORED ON THE PROJECT SITE SHALL BE LIMITED, AS MUCH AS PRACTICAL, TO THAT QUANTITY REQUIRED TO PERFORM THE WORK IN AN ORDERLY SEQUENCE. ALL MATERIALS STORED ON-SITE SHALL BE STORED IN A NEAT, ORDERLY MANNER, IN THEIR ORIGINAL CONTAINERS, WITH ORIGINAL MANUFACTURER'S LABELS.
- NO CHEMICAL(S) HAVING THE POTENTIAL TO BE RELEASED IN STORMWATER ARE TO BE STORED OR USED ON-SITE UNLESS PERMISSION FOR THE USE OF SUCH CHEMICAL(S) IS GRANTED IN WRITING BY THE ECM ADMINISTRATOR. IN GRANTING APPROVAL FOR THE USE OF SUCH CHEMICAL(S), SPECIAL CONDITIONS AND MONITORING MAY BE REQUIRED.
- BULK STORAGE OF ALLOWED PETROLEUM PRODUCTS OR OTHER ALLOWED LIQUID CHEMICALS IN EXCESS OF 55 GALLONS SHALL REQUIRE ADEQUATE SECONDARY CONTAINMENT PROTECTION TO CONTAIN ALL SPILLS ON-SITE AND TO PREVENT ANY SPILLED MATERIALS FROM ENTERING STATE WATERS, ANY SURFACE OR SUBSURFACE STORM DRAINAGE SYSTEM OR OTHER FACILITIES.
- NO PERSON SHALL CAUSE THE IMPEDIMENT OF STORMWATER FLOW IN THE CURB AND GUTTER OR DITCH EXCEPT WITH APPROVED SEDIMENT CONTROL MEASURES.
- OWNER/DEVELOPER AND THEIR AGENTS SHALL COMPLY WITH THE 'COLORADO WATER QUALITY CONTROL ACT' (TITLE 25, ARTICLE 8, CRS), AND THE 'CLEAN WATER ACT' (33 USC 1344), IN ADDITION TO THE REQUIREMENTS OF THE LAND DEVELOPMENT CODE, DOM VOLUME II AND THE ECM APPENDIX I. ALL APPROPRIATE PERMITS MUST BE OBTAINED BY THE CONTRACTOR PRIOR TO CONSTRUCTION (1041, NPDES, FLOODPLAIN, 404, FUGITIVE DUST, ETC.). IN THE EVENT OF CONFLICTS BETWEEN THESE REQUIREMENTS AND OTHER LAWS, RULES, OR REGULATIONS OF OTHER FEDERAL, STATE, LOCAL, OR COUNTY AGENCIES, THE MOST RESTRICTIVE LAWS, RULES, OR REGULATIONS SHALL APPLY.
- ALL CONSTRUCTION TRAFFIC MUST ENTER/EXIT THE SITE ONLY AT APPROVED CONSTRUCTION ACCESS POINTS.
- PRIOR TO CONSTRUCTION THE PERMITTEE SHALL VERIFY THE LOCATION OF EXISTING UTILITIES.
- A WATER SOURCE SHALL BE AVAILABLE ON SITE DURING EARTHWORK OPERATIONS AND SHALL BE UTILIZED AS REQUIRED TO MINIMIZE DUST FROM EARTHWORK EQUIPMENT AND WIND.
- THE SOILS REPORT FOR THIS SITE HAS BEEN PREPARED BY ENTECH ENGINEERING, INC. (DATED 04/07/2020) AND SHALL BE CONSIDERED A PART OF THESE PLANS.
- AT LEAST TEN (10) DAYS PRIOR TO THE ANTICIPATED START OF CONSTRUCTION, FOR PROJECTS THAT WILL DISTURB ONE (1) ACRE OR MORE, THE OWNER OR OPERATOR OF CONSTRUCTION ACTIVITY SHALL SUBMIT A PERMIT APPLICATION FOR STORMWATER DISCHARGE TO THE COLORADO DEPARTMENT OF PUBLIC HEALTH AND ENVIRONMENT, WATER QUALITY DIVISION. THE APPLICATION CONTAINS CERTIFICATION OF COMPLETION OF A STORMWATER MANAGEMENT PLAN (SWMP), OF WHICH THIS GRADING AND EROSION CONTROL PLAN MAY BE A PART. FOR INFORMATION OR APPLICATION MATERIALS CONTACT:

COLORADO DEPARTMENT OF PUBLIC HEALTH AND ENVIRONMENT
 WATER QUALITY CONTROL DIVISION
 WQCD PERMITS
 4300 CHERRY CREEK DRIVE SOUTH
 DENVER, CO 80246-1530
 ATTN: PERMITS UNIT

STANDARD NOTES FOR EL PASO COUNTY CONSTRUCTION PLANS

- ALL DRAINAGE AND ROADWAY CONSTRUCTION SHALL MEET THE STANDARDS AND SPECIFICATIONS OF THE CITY OF COLORADO SPRINGS/EL PASO COUNTY DRAINAGE CRITERIA MANUAL, VOLUMES 1 AND 2, AND THE EL PASO COUNTY ENGINEERING CRITERIA MANUAL.
- CONTRACTOR SHALL BE RESPONSIBLE FOR THE NOTIFICATION AND FIELD NOTIFICATION OF ALL EXISTING UTILITIES, WHETHER SHOWN ON THE PLANS OR NOT, BEFORE BEGINNING CONSTRUCTION. LOCATION OF EXISTING UTILITIES SHALL BE VERIFIED BY THE CONTRACTOR PRIOR TO CONSTRUCTION. CALL 811 TO CONTACT THE UTILITY NOTIFICATION CENTER OF COLORADO (UNCC).
- CONTRACTOR SHALL KEEP A COPY OF THESE APPROVED PLANS, THE GRADING AND EROSION CONTROL PLAN, THE STORMWATER MANAGEMENT PLAN (SWMP), THE SOIL AND GEOTECHNICAL REPORT, AND THE APPROPRIATE DESIGN AND CONSTRUCTION STANDARDS AND SPECIFICATIONS AT THE JOB SITE AT ALL TIMES, INCLUDING THE FOLLOWING:
 - EL PASO COUNTY ENGINEERING CRITERIA MANUAL (ECM)
 - CITY OF COLORADO SPRINGS/ EL PASO COUNTY DRAINAGE CRITERIA MANUAL, VOLUMES 1 AND 2
 - COLORADO DEPARTMENT OF TRANSPORTATION (CDOT) STANDARD SPECIFICATIONS AND BRIDGE CONSTRUCTION
 - CDOT M&S STANDARDS
- NOTWITHSTANDING ANYTHING DEPICTED IN THESE PLANS IN WORDS OR GRAPHIC REPRESENTATION, ALL DESIGN AND CONSTRUCTION RELATED TO ROADS, STORM DRAINAGE AND EROSION CONTROL SHALL CONFORM TO THE STANDARDS AND REQUIREMENTS OF THE MOST RECENT VERSIONS OF THE RELEVANT ADOPTED EL PASO COUNTY STANDARDS, INCLUDING THE LAND DEVELOPMENT CODE, THE ENGINEERING CRITERIA MANUAL, THE DRAINAGE CRITERIA MANUAL, AND THE DRAINAGE CRITERIA MANUAL VOLUME 2. ANY DEVIATIONS FROM REGULATIONS AND STANDARDS MUST BE REQUESTED, AND APPROVED, IN WRITING. ANY MODIFICATIONS NECESSARY TO MEET CRITERIA AFTER-THE-FACT WILL BE ENTIRELY THE DEVELOPER'S RESPONSIBILITY TO RECTIFY.
- IT IS THE DESIGN ENGINEER'S RESPONSIBILITY TO ACCURATELY SHOW EXISTING CONDITIONS, BOTH ON-SITE AND OFF-SITE, ON THE CONSTRUCTION PLANS. ANY MODIFICATIONS NECESSARY DUE TO CONFLICTS, OMISSIONS, OR CHANGED CONDITIONS WILL BE ENTIRELY THE DEVELOPER'S RESPONSIBILITY TO RECTIFY.
- CONTRACTOR SHALL SCHEDULE A PRE-CONSTRUCTION MEETING WITH EL PASO COUNTY PLANNING AND COMMUNITY DEVELOPMENT INSPECTIONS, PRIOR TO STARTING CONSTRUCTION.
- IT IS THE CONTRACTOR'S RESPONSIBILITY TO UNDERSTAND THE REQUIREMENTS OF ALL JURISDICTIONAL AGENCIES TO OBTAIN ALL REQUIRED PERMITS, INCLUDING BUT NOT LIMITED TO EL PASO COUNTY EROSION AND STORMWATER QUALITY CONTROL PERMIT (ESQCP), REGIONAL BUILDING FLOODPLAIN DEVELOPMENT PERMIT, U.S. ARMY CORPS OF ENGINEERS-ISSUED 401 AND/OR 404 PERMITS, AND COUNTY AND STATE FUGITIVE DUST PERMITS.
- CONTRACTOR SHALL NOT DEVIATE FROM THE PLANS WITHOUT FIRST OBTAINING WRITTEN APPROVAL FROM THE DESIGN ENGINEER AND PCD. CONTRACTOR SHALL NOTIFY THE DESIGN ENGINEER IMMEDIATELY UPON DISCOVERY OF ANY ERRORS OR INCONSISTENCIES.
- CONTRACTOR SHALL COORDINATE GEOTECHNICAL TESTING PER ECM STANDARDS. PAVEMENT DESIGN SHALL BE APPROVED BY EL PASO COUNTY PCD PRIOR TO PLACEMENT OF CURB AND GUTTER AND PAVEMENT.
- ALL CONSTRUCTION TRAFFIC MUST ENTER/EXIT THE SITE AT APPROVED CONSTRUCTION ACCESS POINTS.
- SIGHT VISIBILITY TRIANGLES ARE IDENTIFIED IN THE PLANS SHALL BE PROVIDED AT ALL INTERSECTIONS, OBSTRUCTIONS GREATER THAN 18 INCHES ABOVE FLOWLINE ARE NOT ALLOWED IN SIGHT TRIANGLES.
- SIGNING AND STRIPING SHALL COMPLY WITH EL PASO COUNTY DEPARTMENT OF PUBLIC WORKS AND MUTCD CRITERIA.
- CONTRACTOR SHALL OBTAIN ANY PERMITS REQUIRED BY EL PASO COUNTY DEPARTMENT OF PUBLIC WORKS, INCLUDING WORK WITHIN THE RIGHT-OF-WAY AND SPECIAL TRANSPORT PERMITS.
- THE LIMITS OF CONSTRUCTION SHALL REMAIN WITHIN THE PROPERTY LINE UNLESS OTHERWISE NOTED. THE OWNER/DEVELOPER SHALL OBTAIN WRITTEN PERMISSION AND EASEMENTS, WHERE REQUIRED, FROM ADJOINING PROPERTY OWNER(S) PRIOR TO ANY OFF-SITE DISTURBANCE, GRADING, OR CONSTRUCTION.

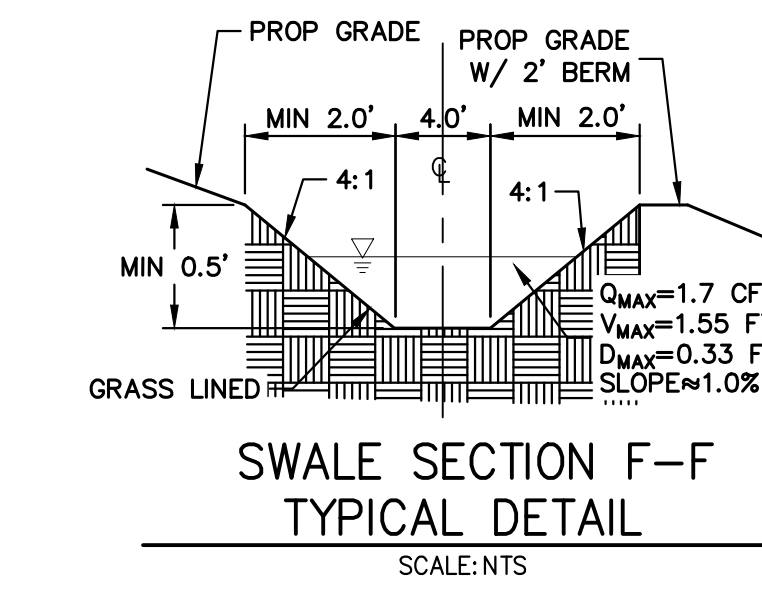
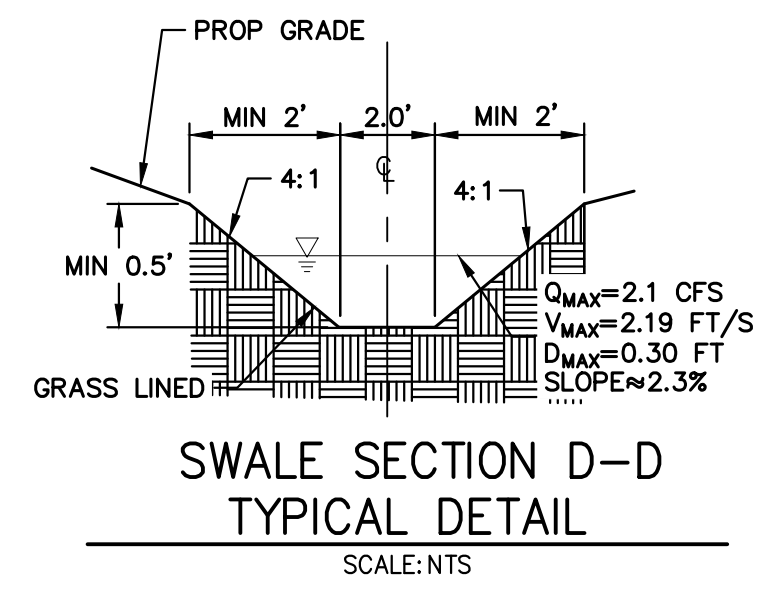
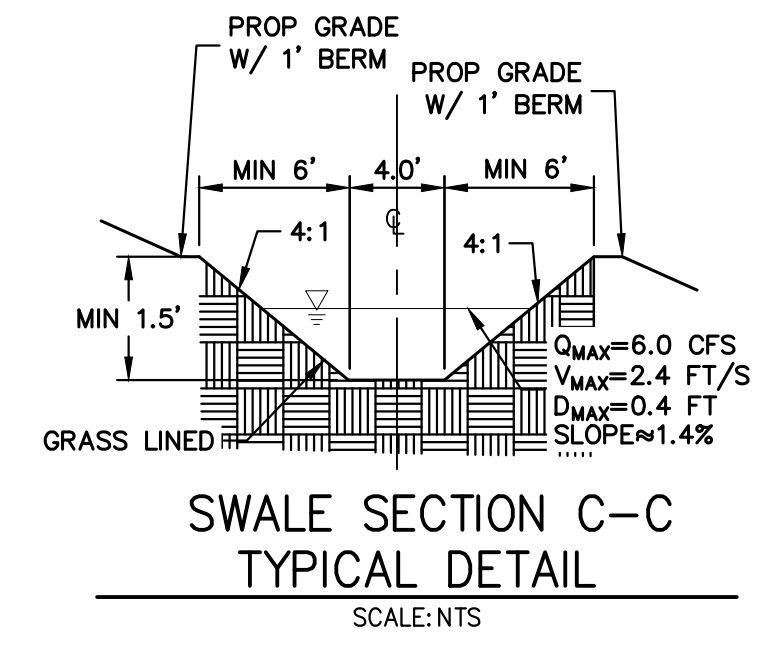
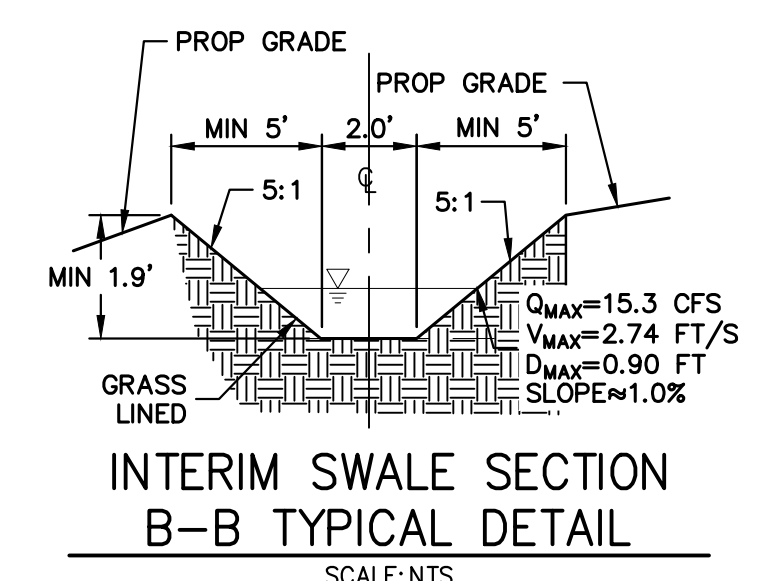
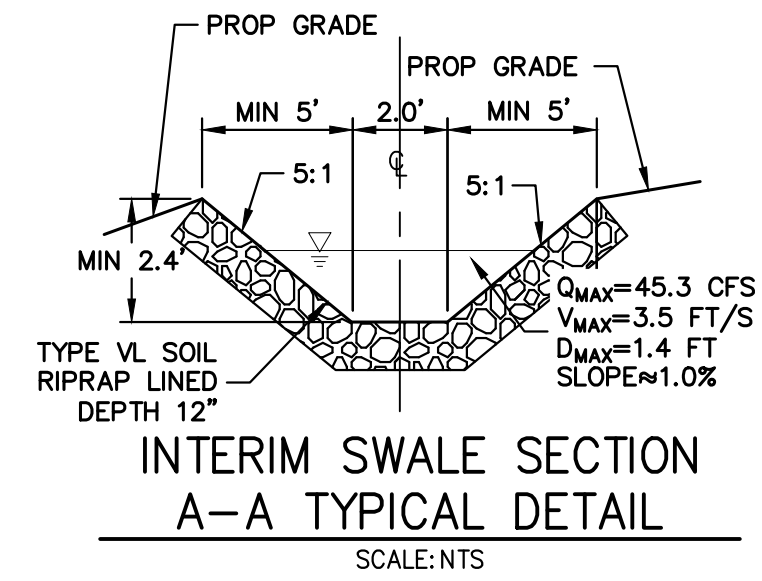

UNTIL SUCH TIME AS THESE DRAWINGS ARE APPROVED BY THE APPROPRIATE REVIEWING AGENCIES, OR ENGINEERING APPROVES THEIR USE, THESE DRAWINGS ARE DESIGNATED BY WRITTEN AUTHORIZATION.

PREPARED FOR
SR LAND, LLC
 20 BOULDER CRESCENT
 SUITE 200
 COLORADO SPRINGS, CO 80903
 JAMES F. MORLEY
 (719) 471-1742

J.R. ENGINEERING
 A Westman Company

 Centennial 303-740-9383 • Colorado Springs 719-583-2583
 Fort Collins 970-491-9888 • www.jrengineering.com

H-SCALE	V-SCALE	DATE	DESIGNED BY	DRAWN BY	CHECKED BY	REVISION	
						No.	DATE
N/A	N/A	11/10/22	N/A	N/A	N/A		

HOMESTEAD NORTH AT STERLING RANCH FILING 2

TYPICAL SECTIONS & NOTES

SHEET 3 OF 16

JOB NO. 25188.10



ENGINEER'S STATEMENT

STANDARD DETAILS SHOWN WERE REVIEWED ONLY AS TO THEIR APPLICATION ON THIS PROJECT

MIKE A. BRAMLETT, P.E.
 COLORADO P.E. 32314
 FOR AND ON BEHALF OF JR ENGINEERING

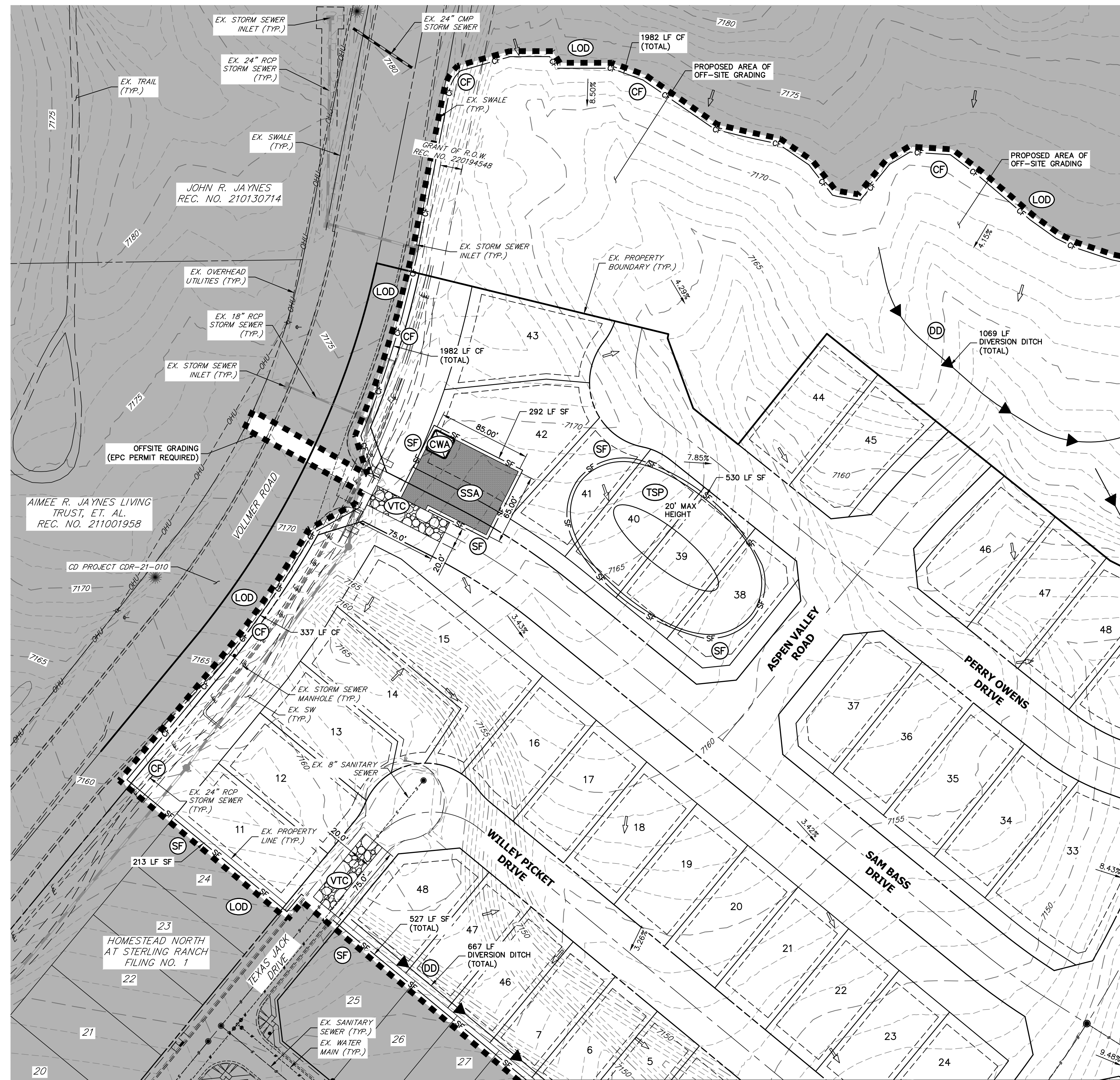

LEGEND

KEY	SYMBOL
CHECK DAM (INTERIM/ FINAL)	CD
CONCRETE WASHOUT AREA (INITIAL)	CWA
DIVERSION DITCH AND DIKE, TEMPORARY (INTERIM/ FINAL)	DD
DIVERSION CHANNEL, TEMPORARY (INTERIM/ FINAL)	DV
EROSION CONTROL BLANKET (FINAL)	ECB
INLET PROTECTION (INITIAL/ INTERIM)	IP
LIMITS OF CONSTRUCTION/DISTURBANCE	LOD
OUTLET PROTECTION (INITIAL/ INTERIM)	OP
PERMANENT SEEDING (FINAL)	PS
FLOW ARROW	→
SEDIMENT CONTROL LOG (INITIAL/ INTERIM)	SCL
CUT/FILL MARK	--- C/F ---
SILT FENCE (INITIAL)	SF
CONSTRUCTION FENCE	CF
STABILIZED STAGING AREA (INITIAL)	SSA
TEMPORARY SEEDING & MULCHING (FINAL)	MUL/TS
VEHICLE TRACKING CONTROL (INITIAL)	VTC
SEDIMENT BASIN (INITIAL)	SB
TEMP. STOCK PILE (INITIAL)	TSP
TEMP. SLOPE DRAIN (INITIAL)	TSD

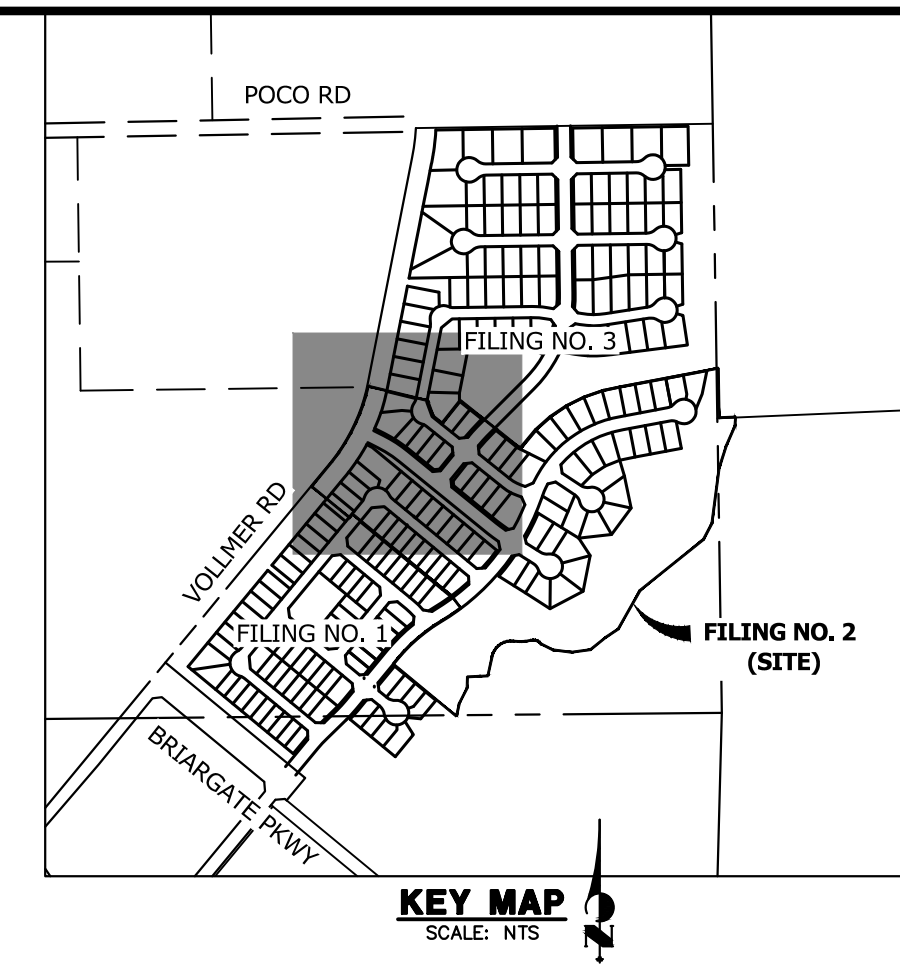

SEE SHEET 5

GRADING, EROSION, AND STORMWATER QUALITY CONTROL PLAN NOTES

- EXISTING VEGETATION ON THE PROJECT SITE CONSISTS OF SPARSE GRASS.
- THE PROPOSED LIMITS OF DISTURBANCE IS OUTSIDE OF THE 100-YEAR FLOODPLAIN PER FEMA FIRM MAP NUMBER 08041C0535G, REVISED DECEMBER 7, 2018.
- THERE ARE NO DEDICATED ASPHALT OR CONCRETE BATCH PLANTS PROPOSED AS PART OF THIS PROJECT.
- DEWATERING OPERATIONS ARE NOT ANTICIPATED FOR THIS PROJECT.
- ALL PROPOSED OFF-SITE STORMWATER CONTROL MEASURES ARE UNDER THE DIRECT CONTROL OR OWNERSHIP OF THE OWNER OR OPERATOR FOR THIS DEVELOPMENT.
- ALL SLOPES 3:1 OR GREATER REQUIRE EROSION CONTROL BLANKET.

BMP PHASING

- INITIAL (SPRING 2023):**
- INSTALL VTC
 - INSTALL CWA
 - ESTABLISH SSA
 - INSTALL CONSTRUCTION FENCE
 - INSTALL SILT FENCE
 - INSTALL SEDIMENT BASINS
 - INSTALL TEMPORARY DIVERSION DITCHES AND TEMPORARY SLOPE DRAINS
 - INSTALL CHECK DAMS
- INTERIM (SPRING 2023 - SUMMER 2023):**
- MAINTAIN ALL BMP'S
 - INSTALL INLET AND OUTLET PROTECTION
 - INSTALL EROSION CONTROL BLANKETS
- FINAL (FALL 2023):**
- INSTALL MULCH AND PERMANENT SEEDING IN ALL DISTURBED AREAS
 - REMOVE ALL TEMPORARY BMP'S AFTER FINAL STABILIZATION
- FINAL STABILIZATION ANTICIPATED FALL 2023

THE LOCATIONS OF EXISTING ABOVE GROUND AND UNDERGROUND UTILITIES ARE SHOWN IN AN APPROXIMATE WAY ONLY. THE CONTRACTOR SHALL DETERMINE THE EXACT LOCATION OF ALL EXISTING UTILITIES BEFORE COMMENCING WORK. THE CONTRACTOR SHALL BE FULLY RESPONSIBLE FOR ANY AND ALL DAMAGES WHICH MIGHT BE CAUSED BY HIS FAILURE TO EXACTLY LOCATE AND PRESERVE ANY AND ALL ABOVE GROUND AND UNDERGROUND UTILITIES.

SEE SHEET 6

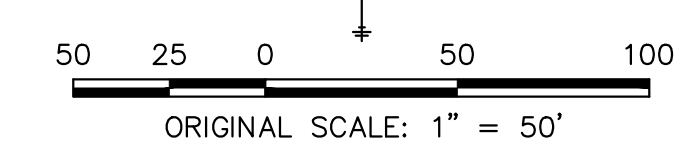

ENGINEER'S STATEMENT

THIS GRADING AND EROSION CONTROL PLAN WAS PREPARED UNDER MY DIRECTION AND SUPERVISION AND IS CORRECT TO THE BEST OF MY KNOWLEDGE AND BELIEF. SAID PLAN HAS BEEN PREPARED ACCORDING TO THE CRITERIA ESTABLISHED BY THE COUNTY FOR GRADING AND EROSION CONTROL PLANS. I ACCEPT RESPONSIBILITY FOR ANY LIABILITY CAUSED BY ANY NEGLIGENT ACTS, ERRORS OR OMISSIONS ON MY PART IN PREPARING THIS PLANS.

MIKE A. BRAMLETT, P.E.
 COLORADO P.E. 32314
 FOR AND ON BEHALF OF JR ENGINEERING

PREPARED FOR SR LAND, LLC 20 BOULDER CRESCENT SUITE 200 COLORADO SPRINGS, CO 80903 JAMES F. MORLEY (719) 471-1742	UNTIL SUCH TIME AS THESE DRAWINGS ARE APPROVED BY THE APPROPRIATE REVIEWING AGENCIES, OR ENGINEERING APPROVES THEIR USE, THESE DRAWINGS ARE DESIGNATED BY WRITTEN AUTHORIZATION.
	J.R. ENGINEERING A Westman Company Centennial 303-740-9888 • Colorado Springs 719-583-2683 Fort Collins 970-491-9888 • www.jrengineering.com
HOMESTEAD NORTH AT STERLING RANCH FILING 2 GEC-INITIAL	SHEET 4 OF 16 JOB NO. 25188.10

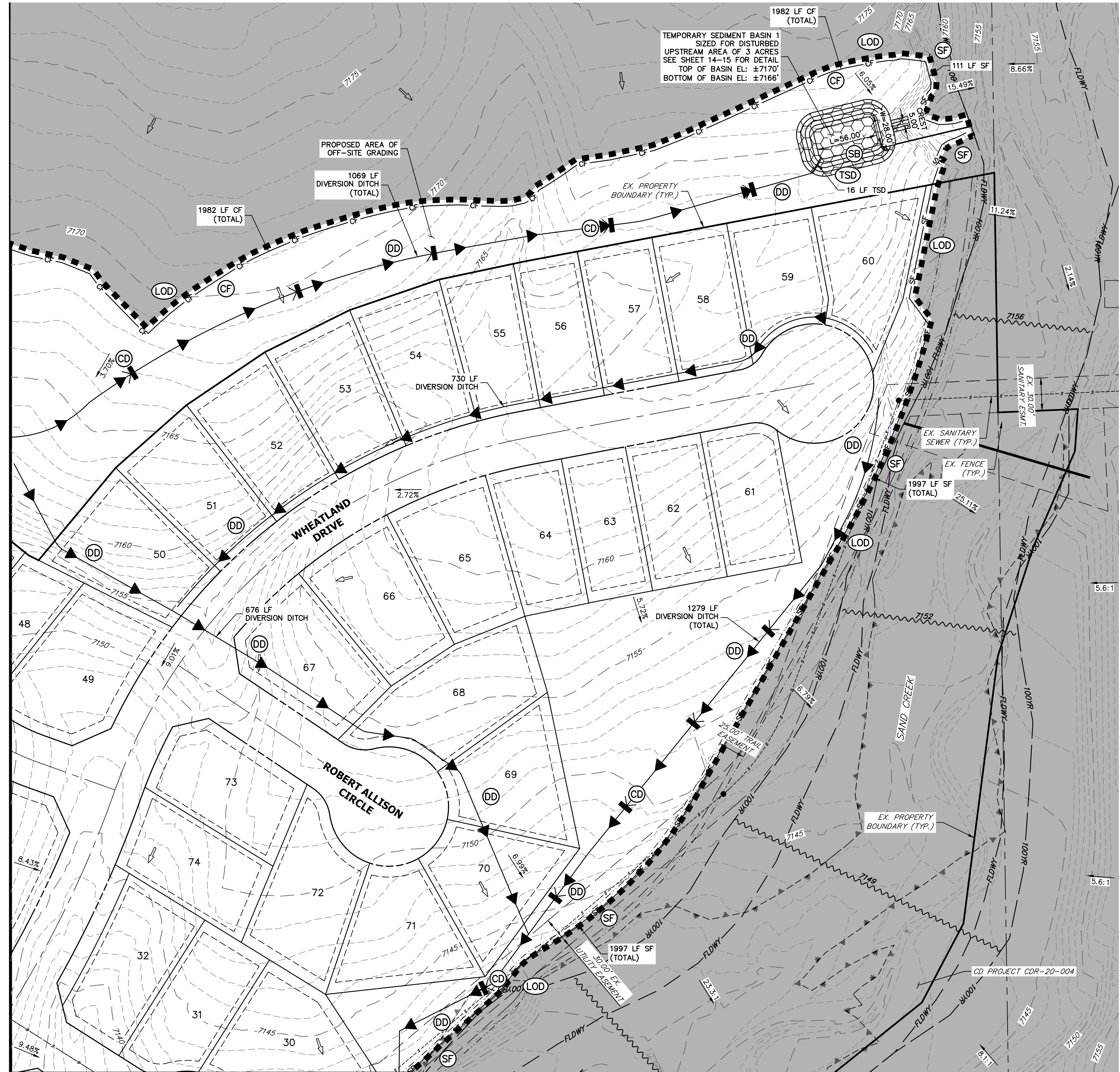

TEMPORARY SEDIMENT BASIN 1
SIZED FOR DISTURBED
UPSTREAM AREA OF 3 ACRES
SEE SHEET 14-15 FOR DETAIL
TOP OF BASIN EL: ±7170'
BOTTOM OF BASIN EL: ±7166'

PROPOSED AREA OF
OFF-SITE GRADING
1069 LF
DIVERSION DITCH
(TOTAL)

730 LF
DIVERSION DITCH

676 LF
DIVERSION DITCH

1279 LF
DIVERSION DITCH
(TOTAL)

1997 LF SF
(TOTAL)

1982 LF CF
(TOTAL)

1982 LF CF
(TOTAL)

1997 LF SF
(TOTAL)

1997 LF SF
(TOTAL)

LEGEND

KEY	SYMBOL
CHECK DAM (INTERIM/ FINAL)	CD
CONCRETE WASHOUT AREA (INITIAL)	CWA
DIVERSION DITCH AND DIKE, TEMPORARY (INTERIM/ FINAL)	DD
DIVERSION CHANNEL, TEMPORARY (INTERIM/ FINAL)	DV
EROSION CONTROL BLANKET (FINAL)	ECB
INLET PROTECTION (INITIAL/ INTERIM)	IP
LIMITS OF CONSTRUCTION/DISTURBANCE	LOD
OUTLET PROTECTION (INITIAL/ INTERIM)	OP
PERMANENT SEEDING (FINAL)	PS
FLOW ARROW	→
SEDIMENT CONTROL LOG (INITIAL/ INTERIM)	SCL
CUT/FILL MARK	--- C/F ---
SILT FENCE (INITIAL)	SF
CONSTRUCTION FENCE	CF
STABILIZED STAGING AREA (INITIAL)	SSA
TEMPORARY SEEDING & MULCHING (FINAL)	MULTS
VEHICLE TRACKING CONTROL (INITIAL)	VTC
SEDIMENT BASIN (INITIAL)	SB
TEMP. STOCK PILE (INITIAL)	TSP
TEMP. SLOPE DRAIN (INITIAL)	TSD

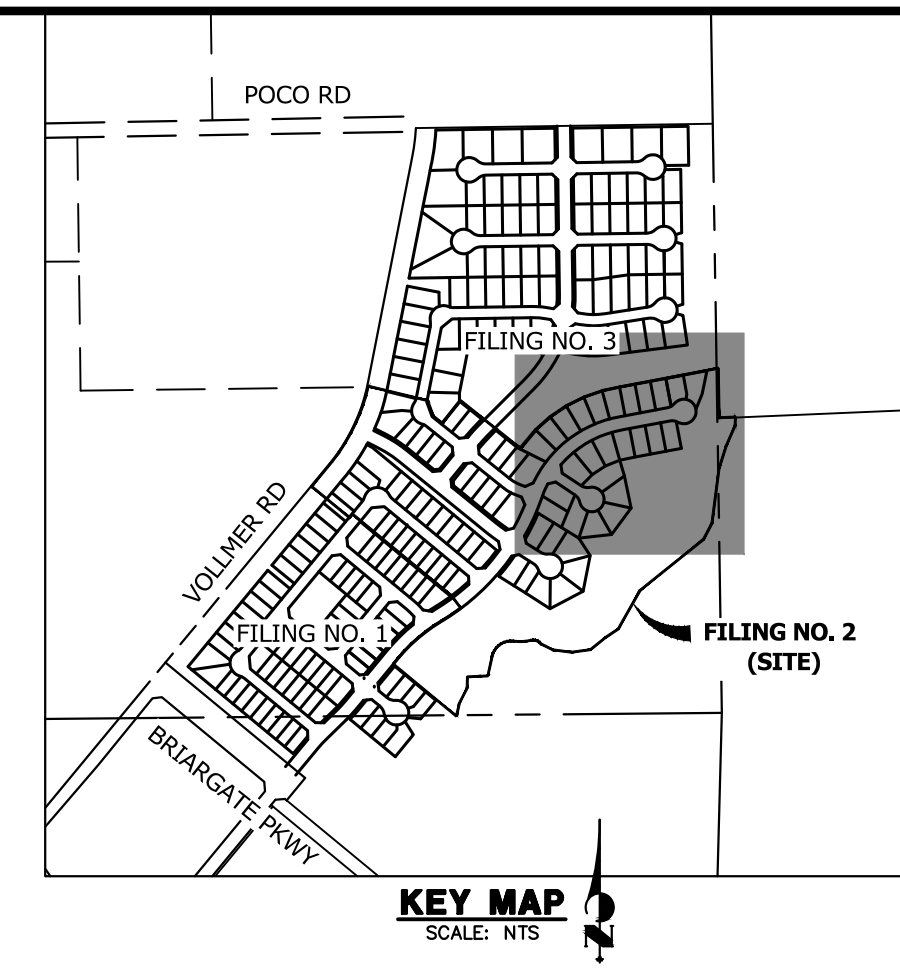

GRADING, EROSION, AND STORMWATER QUALITY CONTROL PLAN NOTES

- EXISTING VEGETATION ON THE PROJECT SITE CONSISTS OF SPARSE GRASS.
- THE PROPOSED LIMITS OF DISTURBANCE IS OUTSIDE OF THE 100-YEAR FLOODPLAIN PER FEMA FIRM MAP NUMBER 08041C05356, REVISED DECEMBER 7, 2018.
- THERE ARE NO DEDICATED ASPHALT OR CONCRETE BATCH PLANTS PROPOSED AS PART OF THIS PROJECT.
- DEWATERING OPERATIONS ARE NOT ANTICIPATED FOR THIS PROJECT.
- ALL PROPOSED OFF-SITE STORMWATER CONTROL MEASURES ARE UNDER THE DIRECT CONTROL OR OWNERSHIP OF THE OWNER OR OPERATOR FOR THIS DEVELOPMENT.
- ALL SLOPES 3:1 OR GREATER REQUIRE EROSION CONTROL BLANKET.

BMP PHASING

- INITIAL (SPRING 2023):**
- INSTALL VTC
 - INSTALL CWA
 - ESTABLISH SSA
 - INSTALL CONSTRUCTION FENCE
 - INSTALL SILT FENCE
 - INSTALL SEDIMENT BASINS
 - INSTALL TEMPORARY DIVERSION DITCHES AND TEMPORARY SLOPE DRAINS
 - INSTALL CHECK DAMS
- INTERIM (SPRING 2023-SUMMER 2023):**
- MAINTAIN ALL BMP'S
 - INSTALL INLET AND OUTLET PROTECTION
 - INSTALL EROSION CONTROL BLANKETS
- FINAL (FALL 2023):**
- INSTALL MULCH AND PERMANENT SEEDING IN ALL DISTURBED AREAS
 - REMOVE ALL TEMPORARY BMP'S AFTER FINAL STABILIZATION
- FINAL STABILIZATION ANTICIPATED FALL 2023

SEE SHEET 4

SEE SHEET 6

THE LOCATIONS OF EXISTING ABOVE GROUND AND UNDERGROUND UTILITIES ARE SHOWN IN AN APPROXIMATE WAY ONLY. THE CONTRACTOR SHALL DETERMINE THE EXACT LOCATION OF ALL EXISTING UTILITIES BEFORE COMMENCING WORK. THE CONTRACTOR SHALL BE FULLY RESPONSIBLE FOR ANY AND ALL DAMAGES WHICH MIGHT BE CAUSED BY HIS FAILURE TO EXACTLY LOCATE AND PRESERVE ANY AND ALL ABOVE GROUND AND UNDERGROUND UTILITIES.

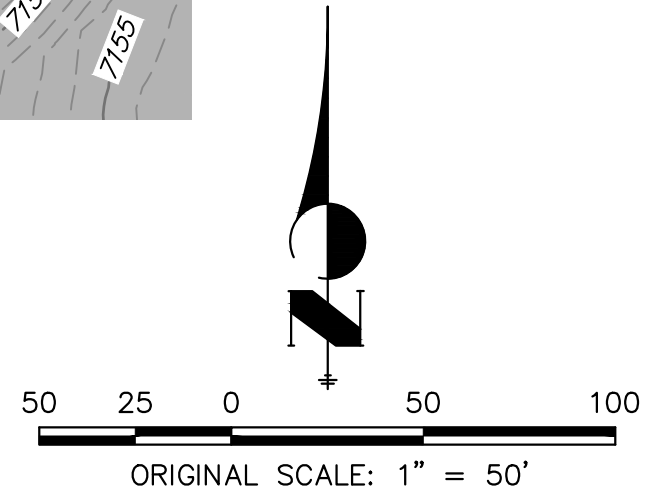

ENGINEER'S STATEMENT

THIS GRADING AND EROSION CONTROL PLAN WAS PREPARED UNDER MY DIRECTION AND SUPERVISION AND IS CORRECT TO THE BEST OF MY KNOWLEDGE AND BELIEF. SAID PLAN HAS BEEN PREPARED ACCORDING TO THE CRITERIA ESTABLISHED BY THE COUNTY FOR GRADING AND EROSION CONTROL PLANS. I ACCEPT RESPONSIBILITY FOR ANY LIABILITY CAUSED BY ANY NEGLIGENT ACTS, ERRORS OR OMISSIONS ON MY PART IN PREPARING THIS PLANS.

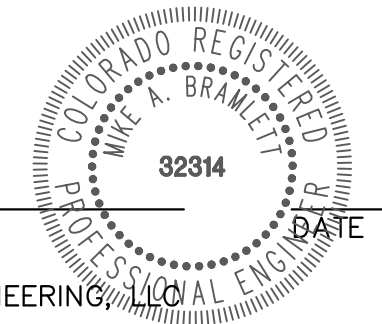

MIKE A. BRAMLETT, P.E.
COLORADO P.E. 32314
FOR AND ON BEHALF OF JR ENGINEERING

PREPARED FOR SR LAND, LLC 20 BOULDER CRESCENT SUITE 200 COLORADO SPRINGS, CO 80903 JAMES F. MORLEY (719) 471-1742	UNTIL SUCH TIME AS THESE DRAWINGS ARE APPROVED BY THE APPROPRIATE REVIEWING AGENCIES, OR ENGINEERING APPROVES THEIR USE. DESIGNATED BY WRITTEN AUTHORIZATION.
BY DATE	No. REVISION
H-SCALE 1"=50' V-SCALE N/A DATE 11/10/22 DESIGNED BY GAG DRAWN BY GAG CHECKED BY	HOMESTEAD NORTH AT STERLING RANCH FILING 2 GEC-INITIAL
SHEET 5 OF 16 JOB NO. 25188.10	

SEE SHEET 4

SEE SHEET 5

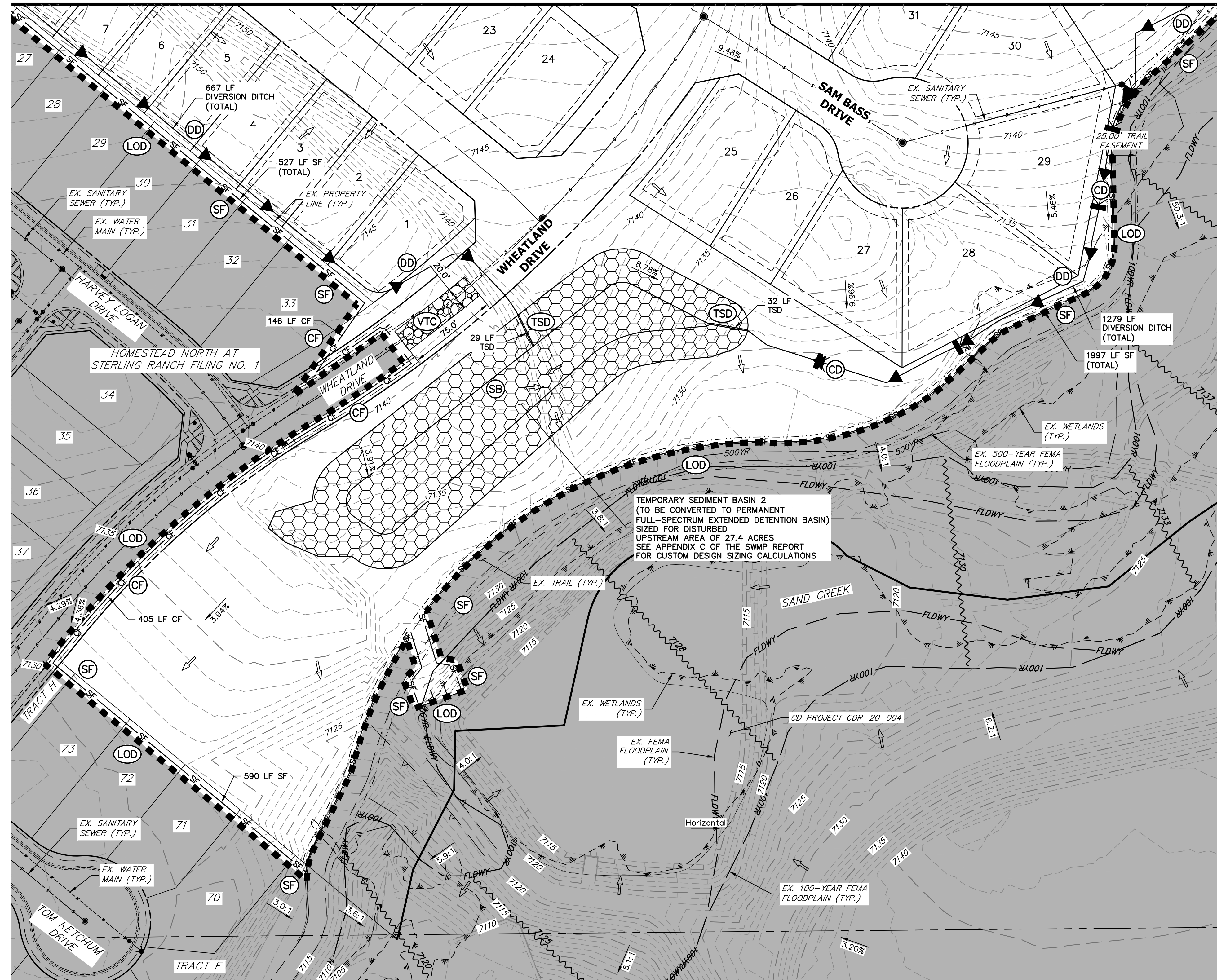

LEGEND

KEY	SYMBOL
CHECK DAM (INTERIM/ FINAL)	CD
CONCRETE WASHOUT AREA (INITIAL)	CWA
DIVERSION DITCH AND DIKE, TEMPORARY (INTERIM/ FINAL)	DD
DIVERSION CHANNEL, TEMPORARY (INTERIM/ FINAL)	DV
EROSION CONTROL BLANKET (FINAL)	ECB
INLET PROTECTION (INITIAL/ INTERIM)	IP
LIMITS OF CONSTRUCTION/DISTURBANCE	LOD
OUTLET PROTECTION (INITIAL/ INTERIM)	OP
PERMANENT SEEDING (FINAL)	PS
FLOW ARROW	→
SEDIMENT CONTROL LOG (INITIAL/ INTERIM)	SCL
CUT/FILL MARK	--- C/F ---
SILT FENCE (INITIAL)	SF
CONSTRUCTION FENCE	CF
STABILIZED STAGING AREA (INITIAL)	SSA
TEMPORARY SEEDING & MULCHING (FINAL)	MU/TS
VEHICLE TRACKING CONTROL (INITIAL)	VTC
SEDIMENT BASIN (INITIAL)	SB
TEMP. STOCK PILE (INITIAL)	TSP
TEMP. SLOPE DRAIN (INITIAL)	TSD

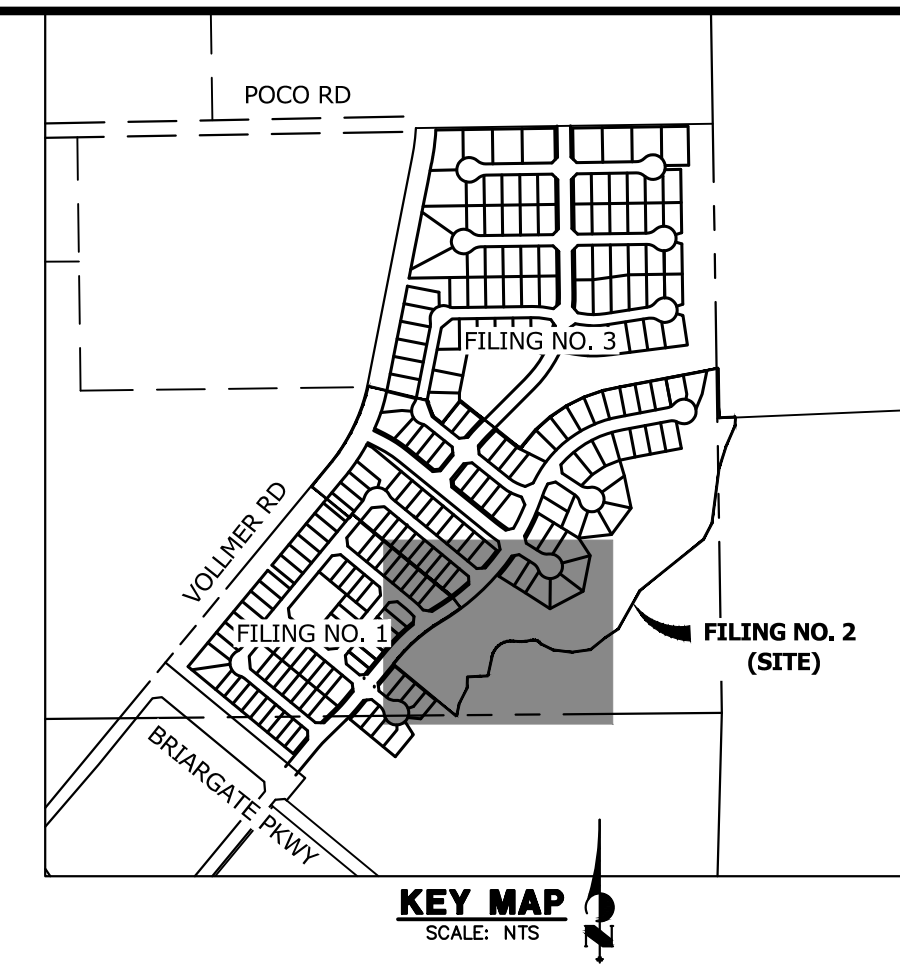

GRADING, EROSION, AND STORMWATER QUALITY CONTROL PLAN NOTES

- EXISTING VEGETATION ON THE PROJECT SITE CONSISTS OF SPARSE GRASS.
- THE PROPOSED LIMITS OF DISTURBANCE IS OUTSIDE OF THE 100-YEAR FLOODPLAIN PER FEMA FIRM MAP NUMBER 08041C0535G, REVISED DECEMBER 7, 2018.
- THERE ARE NO DEDICATED ASPHALT OR CONCRETE BATCH PLANTS PROPOSED AS PART OF THIS PROJECT.
- DEWATERING OPERATIONS ARE NOT ANTICIPATED FOR THIS PROJECT.
- ALL PROPOSED OFF-SITE STORMWATER CONTROL MEASURES ARE UNDER THE DIRECT CONTROL OR OWNERSHIP OF THE OWNER OR OPERATOR FOR THIS DEVELOPMENT.
- ALL SLOPES 3:1 OR GREATER REQUIRE EROSION CONTROL BLANKET.

BMP PHASING

INITIAL (SPRING 2023):

- INSTALL VTC
- INSTALL CWA
- ESTABLISH SSA
- INSTALL CONSTRUCTION FENCE
- INSTALL SILT FENCE
- INSTALL SEDIMENT BASINS
- INSTALL TEMPORARY DIVERSION DITCHES AND TEMPORARY SLOPE DRAINS
- INSTALL CHECK DAMS

INTERIM (SPRING 2023-SUMMER 2023):

- MAINTAIN ALL BMP'S
- INSTALL INLET AND OUTLET PROTECTION
- INSTALL EROSION CONTROL BLANKETS

FINAL (FALL 2023):

- INSTALL MULCH AND PERMANENT SEEDING IN ALL DISTURBED AREAS
- REMOVE ALL TEMPORARY BMP'S AFTER FINAL STABILIZATION

FINAL STABILIZATION ANTICIPATED FALL 2023

THE LOCATIONS OF EXISTING ABOVE GROUND AND UNDERGROUND UTILITIES ARE SHOWN IN AN APPROXIMATE WAY ONLY. THE CONTRACTOR SHALL DETERMINE THE EXACT LOCATION OF ALL EXISTING UTILITIES BEFORE COMMENCING WORK. THE CONTRACTOR SHALL BE FULLY RESPONSIBLE FOR ANY AND ALL DAMAGES WHICH MIGHT BE CAUSED BY HIS FAILURE TO EXACTLY LOCATE AND PRESERVE ANY AND ALL ABOVE GROUND AND UNDERGROUND UTILITIES.

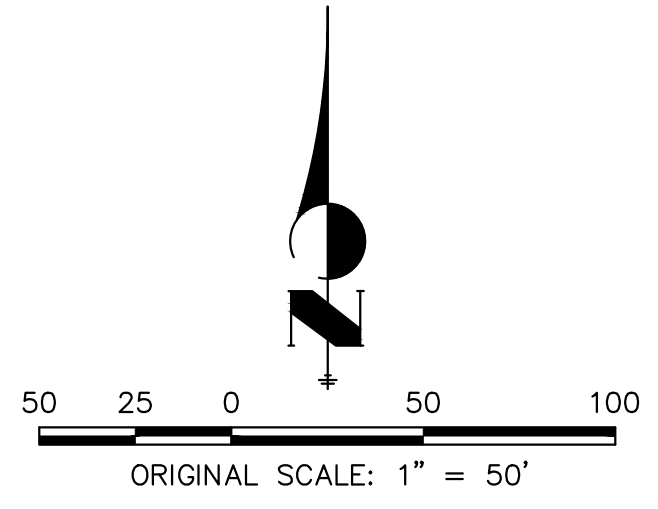

ENGINEER'S STATEMENT

THIS GRADING AND EROSION CONTROL PLAN WAS PREPARED UNDER MY DIRECTION AND SUPERVISION AND IS CORRECT TO THE BEST OF MY KNOWLEDGE AND BELIEF. SAID PLAN HAS BEEN PREPARED ACCORDING TO THE CRITERIA ESTABLISHED BY THE COUNTY FOR GRADING AND EROSION CONTROL PLANS. I ACCEPT RESPONSIBILITY FOR ANY LIABILITY CAUSED BY ANY NEGLIGENT ACTS, ERRORS OR OMISSIONS ON MY PART IN PREPARING THIS PLANS.

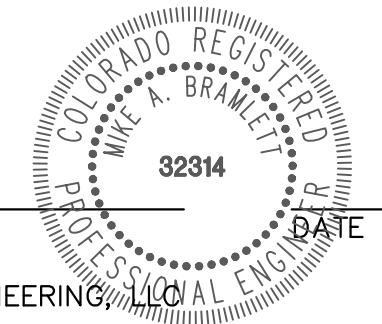

MIKE A. BRAMLETT, P.E.
 COLORADO P.E. 32314
 FOR AND ON BEHALF OF JR ENGINEERING

PREPARED FOR SR LAND, LLC 20 BOULDER CRESCENT SUITE 200 COLORADO SPRINGS, CO 80903 JAMES F. MORLEY (719) 471-1742	UNTIL SUCH TIME AS THESE DRAWINGS ARE APPROVED BY THE APPROPRIATE REVIEWING AGENCIES, OR ENGINEERING APPROVES THEIR USE. DESIGNATED BY WRITTEN AUTHORIZATION.
	J.R. ENGINEERING A Westman Company Centennial 303-740-9888 • Colorado Springs 719-583-2583 Fort Collins 970-491-9888 • www.jrengineering.com
BY DATE	No. REVISION
H-SCALE 1"=50' V-SCALE N/A DATE 11/10/22 DESIGNED BY GAG DRAWN BY GAG CHECKED BY	SHEET 6 OF 16 JOB NO. 25188.10

HOMESTEAD NORTH AT STERLING RANCH FILING 2
 GEC-INITIAL



LEGEND

KEY	SYMBOL
CHECK DAM (INTERIM/ FINAL)	CD
CONCRETE WASHOUT AREA (INITIAL)	CWA
DIVERSION DITCH AND DIKE, TEMPORARY (INTERIM/ FINAL)	DD
DIVERSION CHANNEL, TEMPORARY (INTERIM/ FINAL)	DV
EROSION CONTROL BLANKET (FINAL)	ECB
INLET PROTECTION (INITIAL/ INTERIM)	IP
LIMITS OF CONSTRUCTION/DISTURBANCE	LOD
OUTLET PROTECTION (INITIAL/ INTERIM)	OP
PERMANENT SEEDING (FINAL)	PS
FLOW ARROW	→
SEDIMENT CONTROL LOG (INITIAL/ INTERIM)	SCL
CUT/FILL MARK	C/F
SILT FENCE (INITIAL)	SF
CONSTRUCTION FENCE	CF
STABILIZED STAGING AREA (INITIAL)	SSA
TEMPORARY SEEDING & MULCHING (FINAL)	MULTS
VEHICLE TRACKING CONTROL (INITIAL)	VTC
SEDIMENT BASIN (INITIAL)	SB
TEMP. STOCK PILE (INITIAL)	TSP
TEMP. SLOPE DRAIN (INITIAL)	TSD

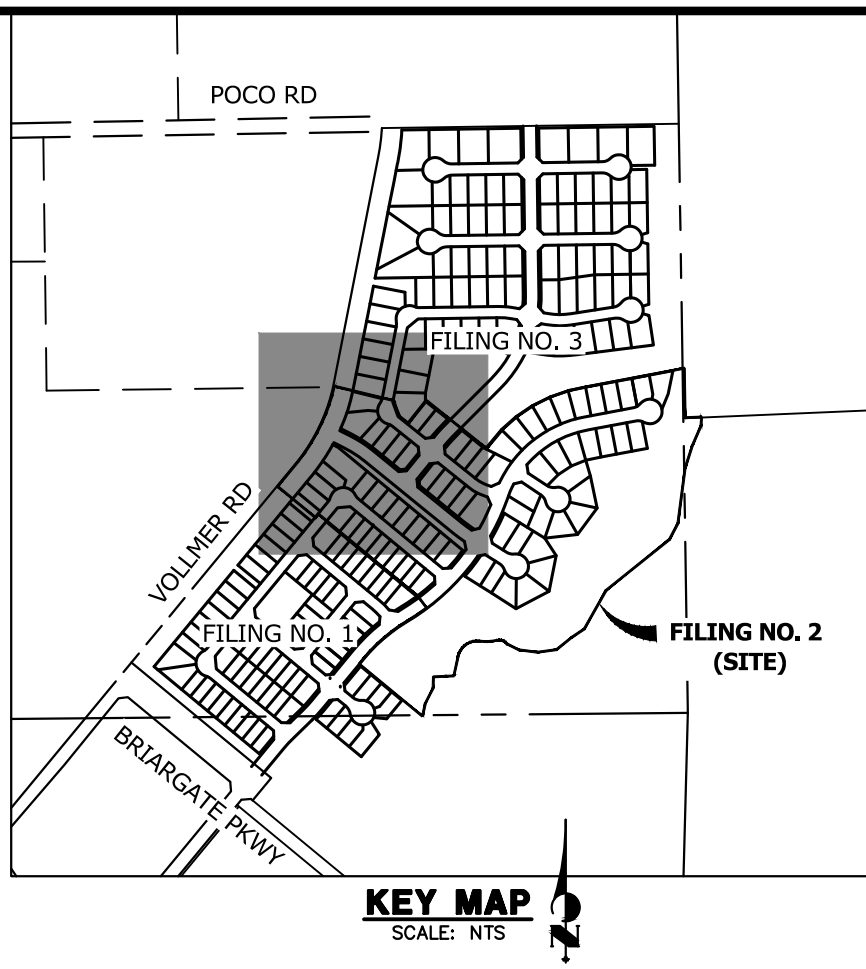

EARTHWORK TOTALS
 CUT: 87,785 CY
 FILL: 77,152 CY
 NET: 10,633 CY <CUT>

GRADING, EROSION, AND STORMWATER QUALITY CONTROL PLAN NOTES

- EXISTING VEGETATION ON THE PROJECT SITE CONSISTS OF SPARSE GRASS.
- THE PROPOSED LIMITS OF DISTURBANCE IS OUTSIDE OF THE 100-YEAR FLOODPLAIN PER FEMA FIRM MAP NUMBER 08041C0535G, REVISED DECEMBER 7, 2018.
- THERE ARE NO DEDICATED ASPHALT OR CONCRETE BATCH PLANTS PROPOSED AS PART OF THIS PROJECT.
- DEWATERING OPERATIONS ARE NOT ANTICIPATED FOR THIS PROJECT.
- ALL PROPOSED OFF-SITE STORMWATER CONTROL MEASURES ARE UNDER THE DIRECT CONTROL OR OWNERSHIP OF THE OWNER OR OPERATOR FOR THIS DEVELOPMENT.
- ALL SLOPES 3:1 OR GREATER REQUIRE EROSION CONTROL BLANKET.

BMP PHASING

- INITIAL (SPRING 2023):**
- INSTALL VTC
 - INSTALL CWA
 - ESTABLISH SSA
 - INSTALL CONSTRUCTION FENCE
 - INSTALL SILT FENCE
 - INSTALL SEDIMENT BASINS
 - INSTALL TEMPORARY DIVERSION DITCHES AND TEMPORARY SLOPE DRAINS
 - INSTALL CHECK DAMS
- INTERIM (SPRING 2023-SUMMER 2023):**
- MAINTAIN ALL BMP'S
 - INSTALL INLET AND OUTLET PROTECTION
 - INSTALL EROSION CONTROL BLANKETS
- FINAL (FALL 2023):**
- INSTALL MULCH AND PERMANENT SEEDING IN ALL DISTURBED AREAS
 - REMOVE ALL TEMPORARY BMP'S AFTER FINAL STABILIZATION
- FINAL STABILIZATION ANTICIPATED FALL 2023

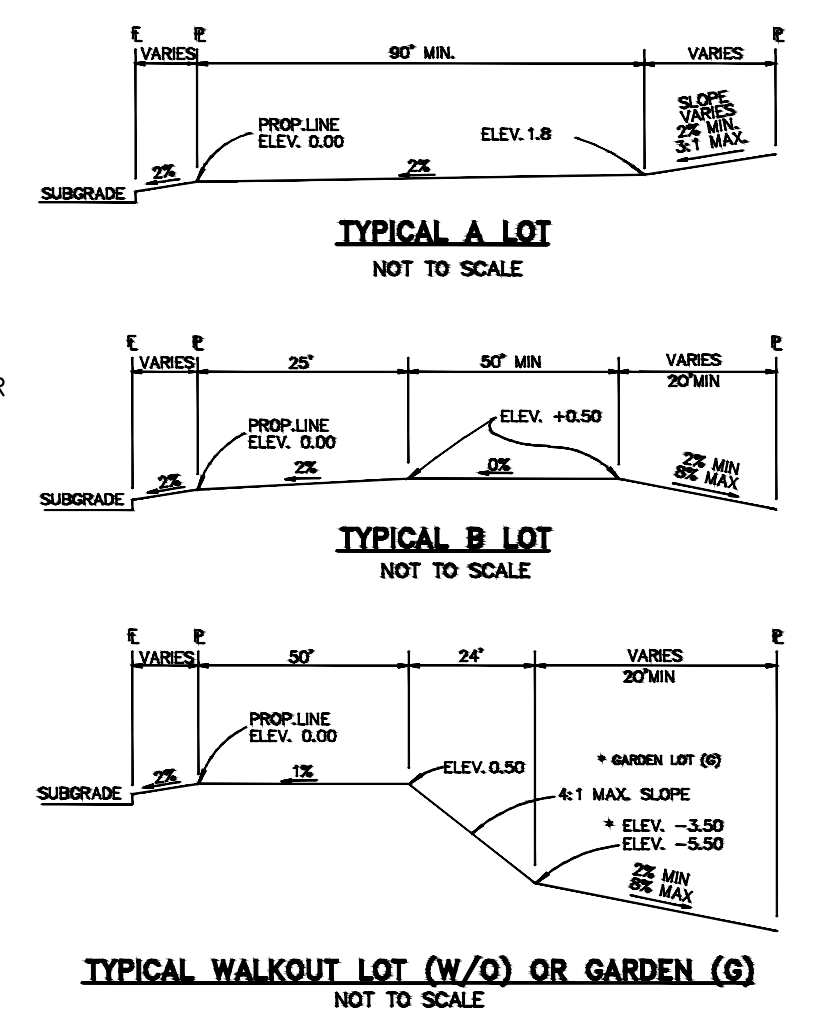

NOTE:
 "T" LOTS OR "TRANSITION" LOTS OCCUR IN PLACES WHERE BOTH PROPERTY LINES CANNOT BE GRADED AS THE TYPICAL STANDARD LOT TEMPLATES SHOWN. THESE LOTS WILL STILL BE GRADED TO CREATE POSITIVE DRAINAGE AWAY FROM THE STRUCTURE.

NOTE:
 SIDE LOT SWALES WILL BE PROVIDED WHEN APPROPRIATE.

ENGINEER'S STATEMENT

THIS GRADING AND EROSION CONTROL PLAN WAS PREPARED UNDER MY DIRECTION AND SUPERVISION AND IS CORRECT TO THE BEST OF MY KNOWLEDGE AND BELIEF. SAID PLAN HAS BEEN PREPARED ACCORDING TO THE CRITERIA ESTABLISHED BY THE COUNTY FOR GRADING AND EROSION CONTROL PLANS. I ACCEPT RESPONSIBILITY FOR ANY LIABILITY CAUSED BY ANY NEGLIGENT ACTS, ERRORS OR OMISSIONS ON MY PART IN PREPARING THIS PLANS.



MIKE A. BRAMLETT, P.E.
 COLORADO P.E. 32314
 FOR AND ON BEHALF OF JR ENGINEERING

THE LOCATIONS OF EXISTING ABOVE GROUND AND UNDERGROUND UTILITIES ARE SHOWN IN AN APPROXIMATE WAY ONLY. THE CONTRACTOR SHALL DETERMINE THE EXACT LOCATION OF ALL EXISTING UTILITIES BEFORE COMMENCING WORK. THE CONTRACTOR SHALL BE FULLY RESPONSIBLE FOR ANY AND ALL DAMAGES WHICH MIGHT BE CAUSED BY HIS FAILURE TO EXACTLY LOCATE AND PRESERVE ANY AND ALL ABOVE GROUND AND UNDERGROUND UTILITIES.

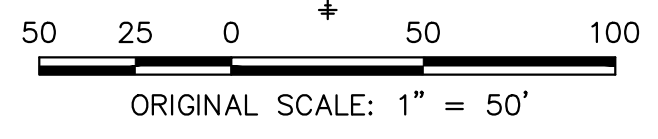

PREPARED FOR
SR LAND, LLC
 20 BOULDER CRESCENT
 SUITE 200
 COLORADO SPRINGS, CO 80903
 JAMES F. MORLEY
 (719) 471-1742

J.R. ENGINEERING
 A Westman Company
 Centennial 303-740-9888 • Colorado Springs 719-583-2683
 Fort Collins 970-491-9888 • www.jrengineering.com

NO.	REVISION	DATE	BY

H-SCALE	V-SCALE	DATE	DESIGNED BY	DRAWN BY	CHECKED BY
1"=50'	N/A	11/10/22	GAG	GAG	

HOMESTEAD NORTH AT STERLING RANCH FILING 2
 GEC-INTERIM

SHEET 7 OF 16
 JOB NO. 25188.10



TEMPORARY SEDIMENT BASIN 1
 SIZED FOR DISTURBED
 UPSTREAM AREA OF 3 ACRES
 SEE SHEET 14-15 FOR DETAIL
 TOP OF BASIN EL: ±7170'
 BOTTOM OF BASIN EL: ±7166'

PROPOSED SWALE (TYP.)
 SEE SHEET 3 FOR TYPICAL SECTIONS

PROPOSED SWALE (TYP.)
 SEE SHEET 3 FOR TYPICAL SECTIONS

LEGEND

KEY	SYMBOL
CHECK DAM (INTERIM/ FINAL)	CD
CONCRETE WASHOUT AREA (INITIAL)	CWA
DIVERSION DITCH AND DIKE, TEMPORARY (INTERIM/ FINAL)	DD
DIVERSION CHANNEL, TEMPORARY (INTERIM/ FINAL)	DV
EROSION CONTROL BLANKET (FINAL)	ECB
INLET PROTECTION (INITIAL/ INTERIM)	IP
LIMITS OF CONSTRUCTION/DISTURBANCE	LOD
OUTLET PROTECTION (INITIAL/ INTERIM)	OP
PERMANENT SEEDING (FINAL)	PS
FLOW ARROW	→
SEDIMENT CONTROL LOG (INITIAL/ INTERIM)	SCL
CUT/FILL MARK	C/F
SILT FENCE (INITIAL)	SF
CONSTRUCTION FENCE	CF
STABILIZED STAGING AREA (INITIAL)	SSA
TEMPORARY SEEDING & MULCHING (FINAL)	MU/TS
VEHICLE TRACKING CONTROL (INITIAL)	VTC
SEDIMENT BASIN (INITIAL)	SB
TEMP. STOCK PILE (INITIAL)	TSP
TEMP. SLOPE DRAIN (INITIAL)	TSD

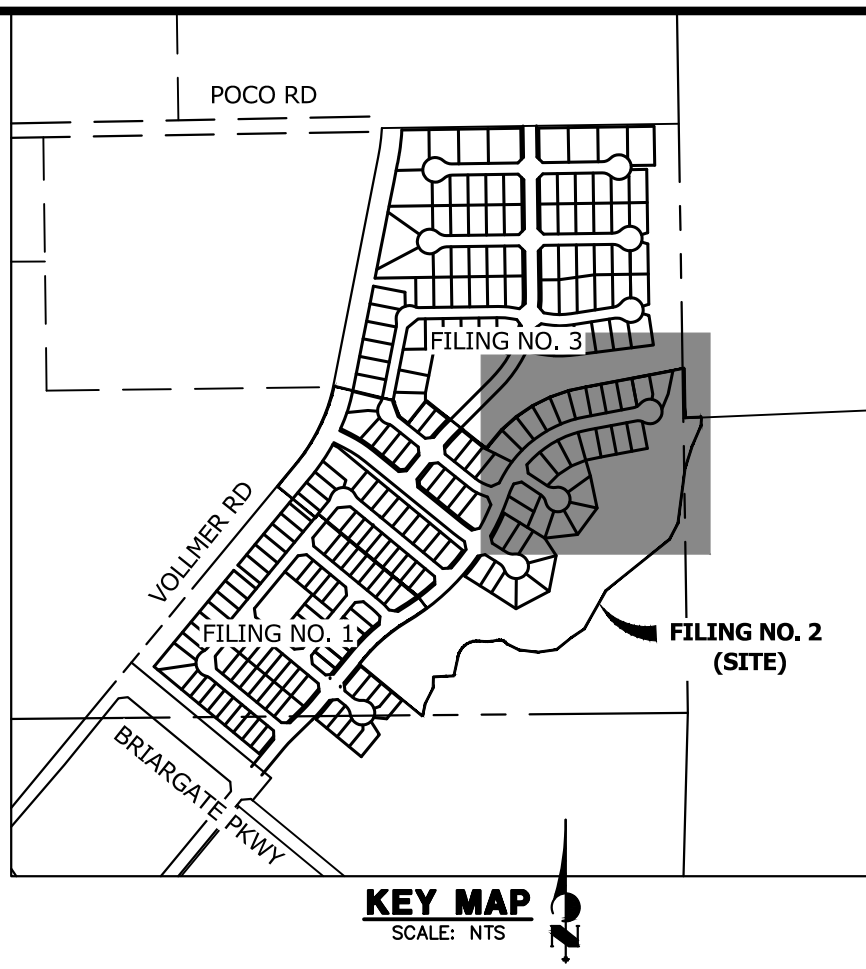

EARTHWORK TOTALS

CUT: 87,785 CY
 FILL: 77,152 CY
 NET: 10,633 CY <CUT>

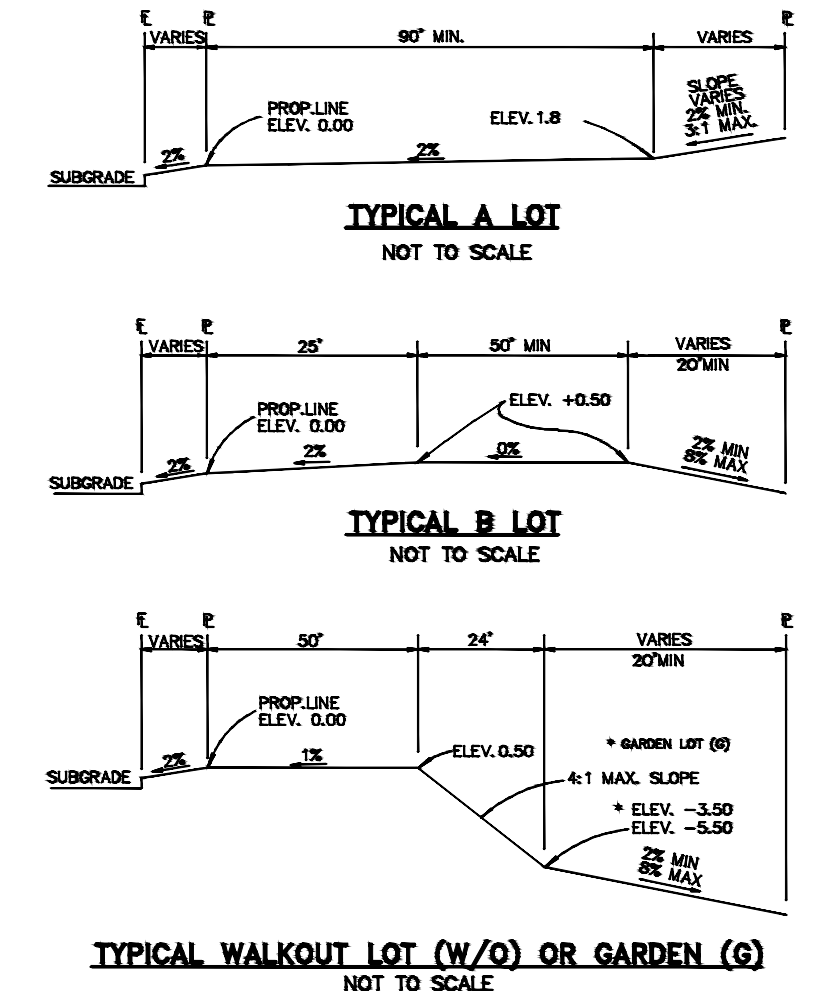

GRADING, EROSION, AND STORMWATER QUALITY CONTROL PLAN NOTES

- EXISTING VEGETATION ON THE PROJECT SITE CONSISTS OF SPARSE GRASS.
- THE PROPOSED LIMITS OF DISTURBANCE IS OUTSIDE OF THE 100-YEAR FLOODPLAIN PER FEMA FIRM MAP NUMBER 08041C0535G, REVISED DECEMBER 7, 2018.
- THERE ARE NO DEDICATED ASPHALT OR CONCRETE BATCH PLANTS PROPOSED AS PART OF THIS PROJECT.
- DEWATERING OPERATIONS ARE NOT ANTICIPATED FOR THIS PROJECT.
- ALL PROPOSED OFF-SITE STORMWATER CONTROL MEASURES ARE UNDER THE DIRECT CONTROL OR OWNERSHIP OF THE OWNER OR OPERATOR FOR THIS DEVELOPMENT.
- ALL SLOPES 3:1 OR GREATER REQUIRE EROSION CONTROL BLANKET.

BMP PHASING

- INITIAL (SPRING 2023):**
- INSTALL VTC
 - INSTALL CWA
 - ESTABLISH SSA
 - INSTALL CONSTRUCTION FENCE
 - INSTALL SILT FENCE
 - INSTALL SEDIMENT BASINS
 - INSTALL TEMPORARY DIVERSION DITCHES AND TEMPORARY SLOPE DRAINS
 - INSTALL CHECK DAMS
- INTERIM (SPRING 2023-SUMMER 2023):**
- MAINTAIN ALL BMP'S
 - INSTALL INLET AND OUTLET PROTECTION
 - INSTALL EROSION CONTROL BLANKETS
- FINAL (FALL 2023):**
- INSTALL MULCH AND PERMANENT SEEDING IN ALL DISTURBED AREAS
 - REMOVE ALL TEMPORARY BMP'S AFTER FINAL STABILIZATION
- FINAL STABILIZATION ANTICIPATED FALL 2023

ENGINEER'S STATEMENT

THIS GRADING AND EROSION CONTROL PLAN WAS PREPARED UNDER MY DIRECTION AND SUPERVISION AND IS CORRECT TO THE BEST OF MY KNOWLEDGE AND BELIEF. SAID PLAN HAS BEEN PREPARED ACCORDING TO THE CRITERIA ESTABLISHED BY THE COUNTY FOR GRADING AND EROSION CONTROL PLANS. I ACCEPT RESPONSIBILITY FOR ANY LIABILITY CAUSED BY ANY NEGLIGENT ACTS, ERRORS OR OMISSIONS ON MY PART IN PREPARING THIS PLANS.



MIKE A. BRAMLETT, P.E.
 COLORADO P.E. 32314
 FOR AND ON BEHALF OF JR ENGINEERING

THE LOCATIONS OF EXISTING ABOVE GROUND AND UNDERGROUND UTILITIES ARE SHOWN IN AN APPROXIMATE WAY ONLY. THE CONTRACTOR SHALL DETERMINE THE EXACT LOCATION OF ALL EXISTING UTILITIES BEFORE COMMENCING WORK. THE CONTRACTOR SHALL BE FULLY RESPONSIBLE FOR ANY AND ALL DAMAGES WHICH MIGHT BE CAUSED BY HIS FAILURE TO EXACTLY LOCATE AND PRESERVE ANY AND ALL ABOVE GROUND AND UNDERGROUND UTILITIES.

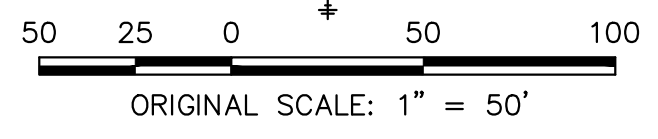

PREPARED FOR
SR LAND, LLC
 20 BOULDER CRESCENT
 SUITE 200
 COLORADO SPRINGS, CO 80903
 JAMES F. MORLEY
 (719) 471-1742

J.R. ENGINEERING
 A Westman Company
 Centennial 303-740-9888 • Colorado Springs 719-583-2583
 Fort Collins 970-491-9888 • www.jrengineering.com

No.	REVISION	BY	DATE

H-SCALE	V-SCALE	DATE	DESIGNED BY	DRAWN BY	CHECKED BY
1"=50'	N/A	11/10/22	GAG	GAG	

HOMESTEAD NORTH AT STERLING RANCH FILING 2
 GEC-INTERIM

SHEET 8 OF 16
 JOB NO. 25188.10

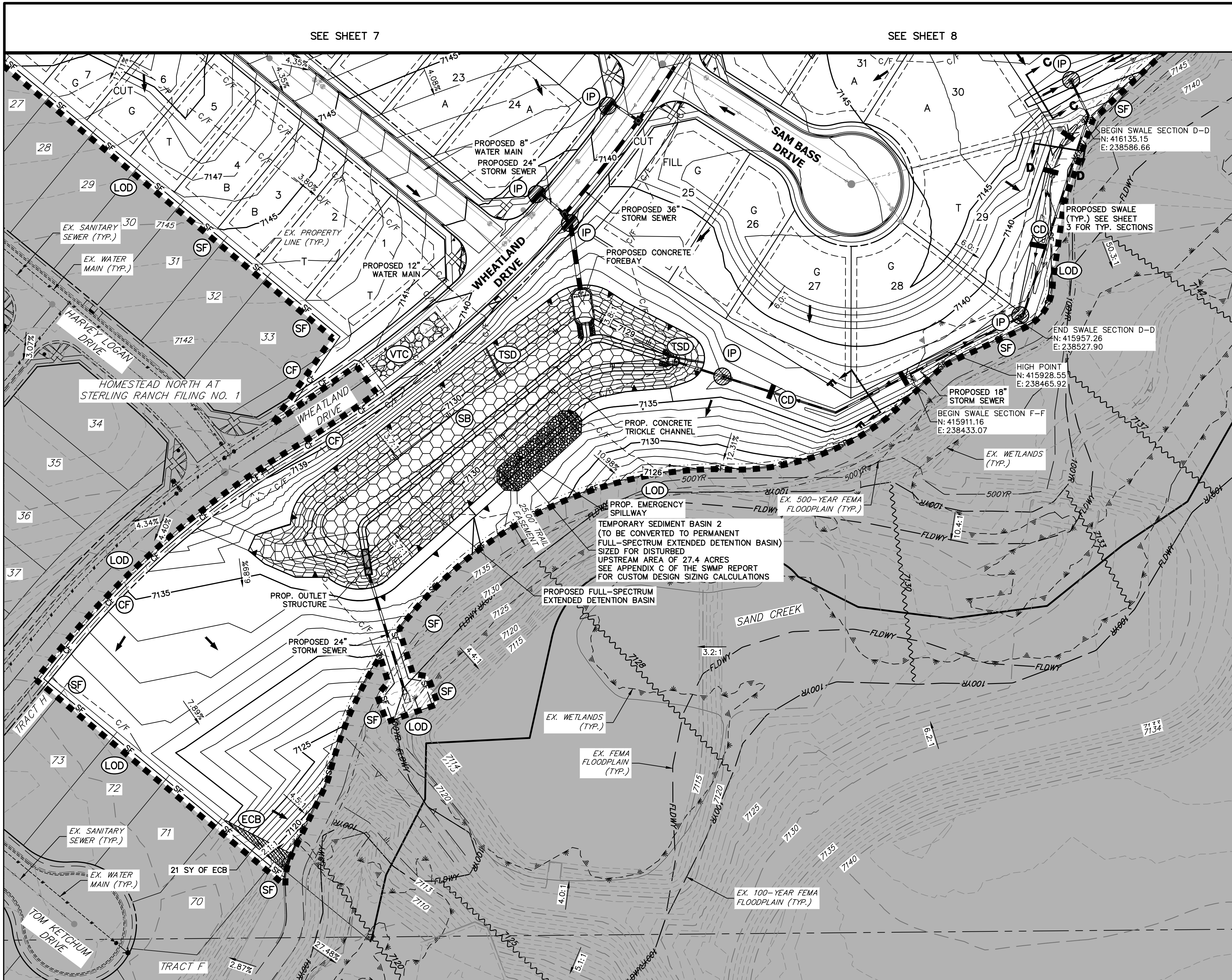

SEE SHEET 7

SEE SHEET 8

LEGEND

KEY	SYMBOL
CHECK DAM (INTERIM/ FINAL)	CD
CONCRETE WASHOUT AREA (INITIAL)	CWA
DIVERSION DITCH AND DIKE, TEMPORARY (INTERIM/ FINAL)	DD
DIVERSION CHANNEL, TEMPORARY (INTERIM/ FINAL)	DV
EROSION CONTROL BLANKET (FINAL)	ECB
INLET PROTECTION (INITIAL/ INTERIM)	IP
LIMITS OF CONSTRUCTION/DISTURBANCE	LOD
OUTLET PROTECTION (INITIAL/ INTERIM)	OP
PERMANENT SEEDING (FINAL)	PS
FLOW ARROW	→
SEDIMENT CONTROL LOG (INITIAL/ INTERIM)	SCL
CUT/FILL MARK	C/F
SILT FENCE (INITIAL)	SF
CONSTRUCTION FENCE	CF
STABILIZED STAGING AREA (INITIAL)	SSA
TEMPORARY SEEDING & MULCHING (FINAL)	MULTS
VEHICLE TRACKING CONTROL (INITIAL)	VTC
SEDIMENT BASIN (INITIAL)	SB
TEMP. STOCK PILE (INITIAL)	TSP
TEMP. SLOPE DRAIN (INITIAL)	TSD

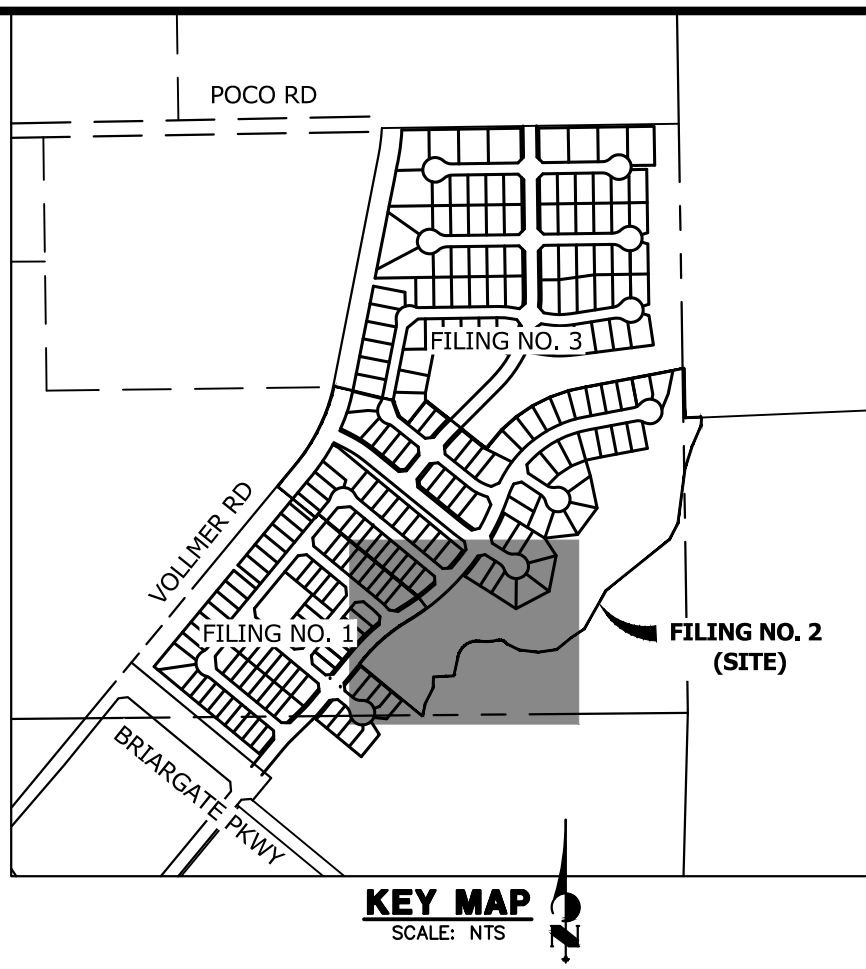

EARTHWORK TOTALS

CUT: 87,785 CY
 FILL: 77,152 CY
 NET: 10,633 CY <CUT>

GRADING, EROSION, AND STORMWATER QUALITY CONTROL PLAN NOTES

- EXISTING VEGETATION ON THE PROJECT SITE CONSISTS OF SPARSE GRASS.
- THE PROPOSED LIMITS OF DISTURBANCE IS OUTSIDE OF THE 100-YEAR FLOODPLAIN PER FEMA FIRM MAP NUMBER 08041C0535G, REVISED DECEMBER 7, 2018.
- THERE ARE NO DEDICATED ASPHALT OR CONCRETE BATCH PLANTS PROPOSED AS PART OF THIS PROJECT.
- DEWATERING OPERATIONS ARE NOT ANTICIPATED FOR THIS PROJECT.
- ALL PROPOSED OFF-SITE STORMWATER CONTROL MEASURES ARE UNDER THE DIRECT CONTROL OR OWNERSHIP OF THE OWNER OR OPERATOR FOR THIS DEVELOPMENT.
- ALL SLOPES 3:1 OR GREATER REQUIRE EROSION CONTROL BLANKET.

BMP PHASING

- INITIAL (SPRING 2023):**
- INSTALL VTC
 - INSTALL CWA
 - ESTABLISH SSA
 - INSTALL CONSTRUCTION FENCE
 - INSTALL SILT FENCE
 - INSTALL SEDIMENT BASINS
 - INSTALL TEMPORARY DIVERSION DITCHES AND TEMPORARY SLOPE DRAINS
 - INSTALL CHECK DAMS
- INTERIM (SPRING 2023-SUMMER 2023):**
- MAINTAIN ALL BMP'S
 - INSTALL INLET AND OUTLET PROTECTION
 - INSTALL EROSION CONTROL BLANKETS
- FINAL (FALL 2023):**
- INSTALL MULCH AND PERMANENT SEEDING IN ALL DISTURBED AREAS
 - REMOVE ALL TEMPORARY BMP'S AFTER FINAL STABILIZATION
- FINAL STABILIZATION ANTICIPATED FALL 2023

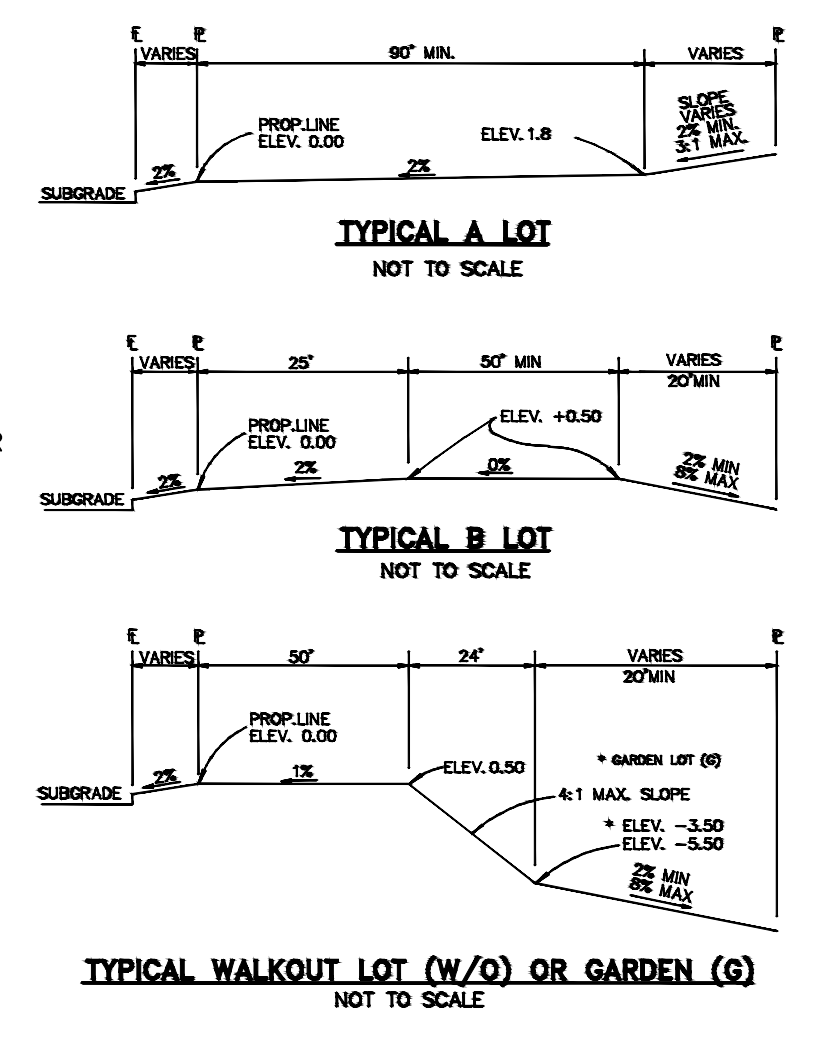

NOTE:
 "T" LOTS OR "TRANSITION" LOTS OCCUR IN PLACES WHERE BOTH PROPERTY LINES CANNOT BE GRADED AS THE TYPICAL STANDARD LOT TEMPLATES SHOWN. THESE LOTS WILL STILL BE GRADED TO CREATE POSITIVE DRAINAGE AWAY FROM THE STRUCTURE.

NOTE:
 SIDE LOT SWALES WILL BE PROVIDED WHEN APPROPRIATE.

THE LOCATIONS OF EXISTING ABOVE GROUND AND UNDERGROUND UTILITIES ARE SHOWN IN AN APPROXIMATE WAY ONLY. THE CONTRACTOR SHALL DETERMINE THE EXACT LOCATION OF ALL EXISTING UTILITIES BEFORE COMMENCING WORK. THE CONTRACTOR SHALL BE FULLY RESPONSIBLE FOR ANY AND ALL DAMAGES WHICH MIGHT BE CAUSED BY HIS FAILURE TO EXACTLY LOCATE AND PRESERVE ANY AND ALL ABOVE GROUND AND UNDERGROUND UTILITIES.



ENGINEER'S STATEMENT

THIS GRADING AND EROSION CONTROL PLAN WAS PREPARED UNDER MY DIRECTION AND SUPERVISION AND IS CORRECT TO THE BEST OF MY KNOWLEDGE AND BELIEF. SAID PLAN HAS BEEN PREPARED ACCORDING TO THE CRITERIA ESTABLISHED BY THE COUNTY FOR GRADING AND EROSION CONTROL PLANS. I ACCEPT RESPONSIBILITY FOR ANY LIABILITY CAUSED BY ANY NEGLIGENT ACTS, ERRORS OR OMISSIONS ON MY PART IN PREPARING THIS PLANS.

MIKE A. BRAMLETT, P.E.
 COLORADO P.E. 32314
 FOR AND ON BEHALF OF JR ENGINEERING

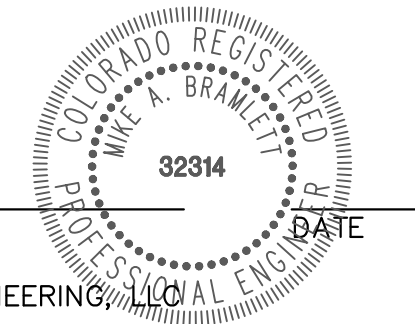

PREPARED FOR
SR LAND, LLC
 20 BOULDER CRESCENT
 SUITE 200
 COLORADO SPRINGS, CO 80903
 JAMES F. MORLEY
 (719) 471-1742

J.R. ENGINEERING
 A Westman Company
 Centennial 303-740-9383 • Colorado Springs 719-583-2593
 Fort Collins 970-491-9888 • www.jrengineering.com

NO.	REVISION	BY	DATE

H-SCALE: 1"=50'
 V-SCALE: N/A
 DATE: 11/10/22
 DESIGNED BY: GAG
 DRAWN BY: GAG
 CHECKED BY: GAG

HOMESTEAD NORTH AT STERLING RANCH FILING 2
 GEC-INTERIM

SHEET 9 OF 16
 JOB NO. 25188.10



LEGEND

KEY	SYMBOL
CHECK DAM (INTERIM/ FINAL)	CD
CONCRETE WASHOUT AREA (INITIAL)	CWA
DIVERSION DITCH AND DIKE, TEMPORARY (INTERIM/ FINAL)	DD
DIVERSION CHANNEL, TEMPORARY (INTERIM/ FINAL)	DV
EROSION CONTROL BLANKET (FINAL)	ECB
INLET PROTECTION (INITIAL/ INTERIM)	IP
LIMITS OF CONSTRUCTION/DISTURBANCE	LOD
OUTLET PROTECTION (INITIAL/ INTERIM)	OP
PERMANENT SEEDING (FINAL)	PS
FLOW ARROW	→
SEDIMENT CONTROL LOG (INITIAL/ INTERIM)	SCL
CUT/FILL MARK	C/F
SILT FENCE (INITIAL)	SF
CONSTRUCTION FENCE	CF
STABILIZED STAGING AREA (INITIAL)	SSA
TEMPORARY SEEDING & MULCHING (FINAL)	MU/TS
VEHICLE TRACKING CONTROL (INITIAL)	VTC
SEDIMENT BASIN (INITIAL)	SB
TEMP. STOCK PILE (INITIAL)	TSP
TEMP. SLOPE DRAIN (INITIAL)	TSD

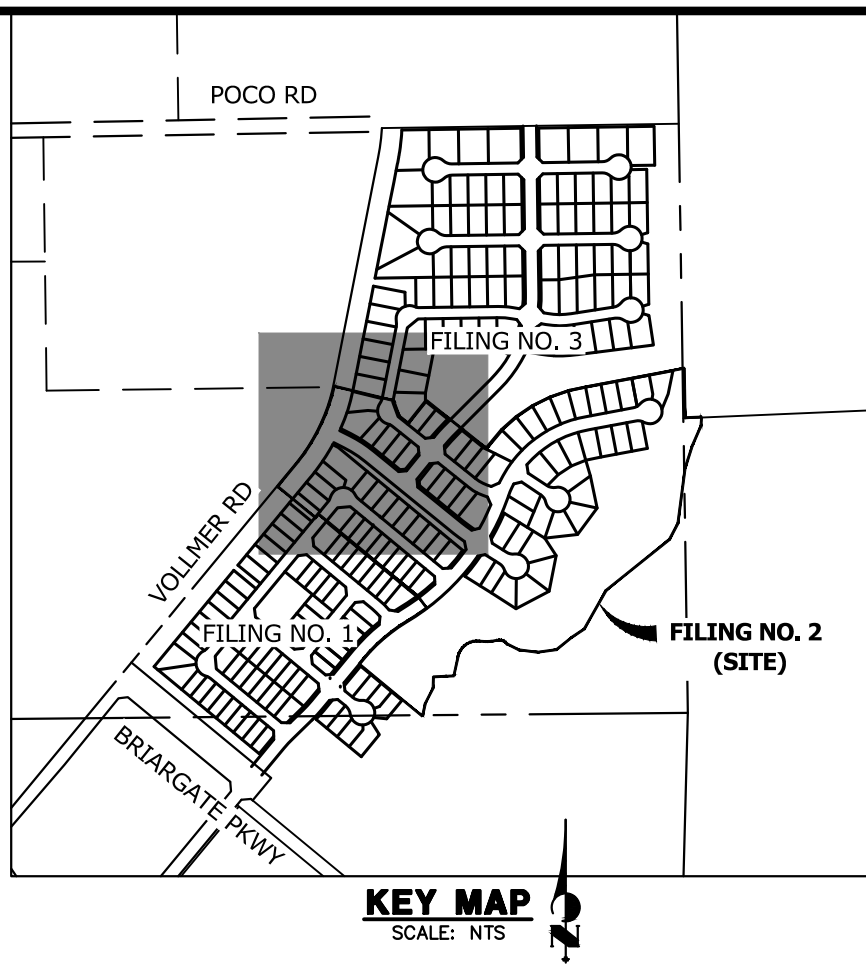

EARTHWORK TOTALS
 CUT: 87,785 CY
 FILL: 77,152 CY
 NET: 10,633 CY <CUT>

SEE SHEET 11

GRADING, EROSION, AND STORMWATER QUALITY CONTROL PLAN NOTES

- EXISTING VEGETATION ON THE PROJECT SITE CONSISTS OF SPARSE GRASS.
- THE PROPOSED LIMITS OF DISTURBANCE IS OUTSIDE OF THE 100-YEAR FLOODPLAIN PER FEMA FIRM MAP NUMBER 08041C0535G, REVISED DECEMBER 7, 2018.
- THERE ARE NO DEDICATED ASPHALT OR CONCRETE BATCH PLANTS PROPOSED AS PART OF THIS PROJECT.
- DEWATERING OPERATIONS ARE NOT ANTICIPATED FOR THIS PROJECT.
- ALL PROPOSED OFF-SITE STORMWATER CONTROL MEASURES ARE UNDER THE DIRECT CONTROL OR OWNERSHIP OF THE OWNER OR OPERATOR FOR THIS DEVELOPMENT.
- ALL SLOPES 3:1 OR GREATER REQUIRE EROSION CONTROL BLANKET.

BMP PHASING

- INITIAL (SPRING 2023):**
- INSTALL VTC
 - INSTALL CWA
 - ESTABLISH SSA
 - INSTALL CONSTRUCTION FENCE
 - INSTALL SILT FENCE
 - INSTALL SEDIMENT BASINS
 - INSTALL TEMPORARY DIVERSION DITCHES AND TEMPORARY SLOPE DRAINS
 - INSTALL CHECK DAMS
- INTERIM (SPRING 2023-SUMMER 2023):**
- MAINTAIN ALL BMP'S
 - INSTALL INLET AND OUTLET PROTECTION
 - INSTALL EROSION CONTROL BLANKETS
- FINAL (FALL 2023):**
- INSTALL MULCH AND PERMANENT SEEDING IN ALL DISTURBED AREAS
 - REMOVE ALL TEMPORARY BMP'S AFTER FINAL STABILIZATION
- FINAL STABILIZATION ANTICIPATED FALL 2023

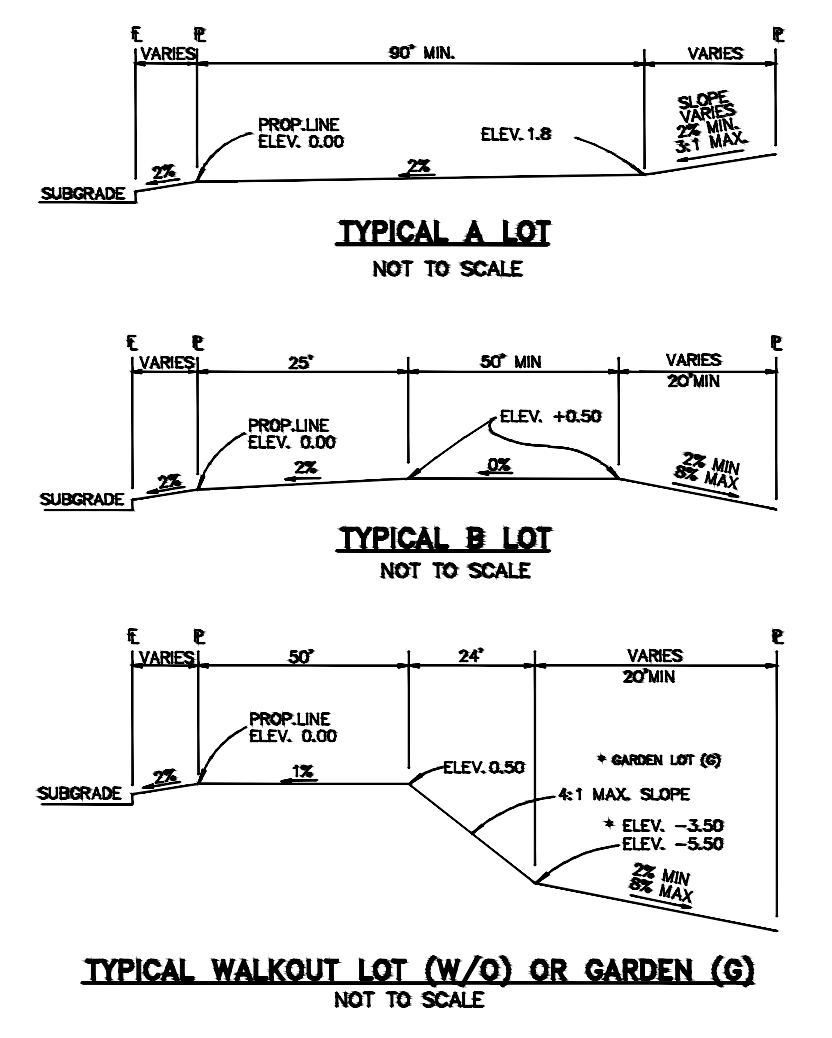

NOTE:
 "T" LOTS OR "TRANSITION" LOTS OCCUR IN PLACES WHERE BOTH PROPERTY LINES CANNOT BE GRADED AS THE TYPICAL STANDARD LOT TEMPLATES SHOWN. THESE LOTS WILL STILL BE GRADED TO CREATE POSITIVE DRAINAGE AWAY FROM THE STRUCTURE.

NOTE:
 SIDE LOT SWALES WILL BE PROVIDED WHEN APPROPRIATE.

ENGINEER'S STATEMENT

THIS GRADING AND EROSION CONTROL PLAN WAS PREPARED UNDER MY DIRECTION AND SUPERVISION AND IS CORRECT TO THE BEST OF MY KNOWLEDGE AND BELIEF. SAID PLAN HAS BEEN PREPARED ACCORDING TO THE CRITERIA ESTABLISHED BY THE COUNTY FOR GRADING AND EROSION CONTROL PLANS. I ACCEPT RESPONSIBILITY FOR ANY LIABILITY CAUSED BY ANY NEGLIGENT ACTS, ERRORS OR OMISSIONS ON MY PART IN PREPARING THIS PLANS.

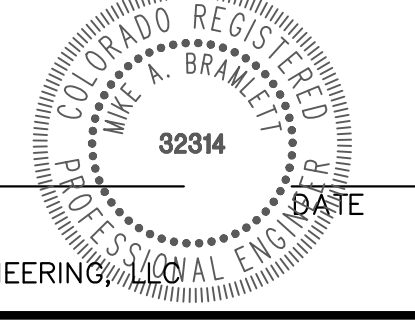

MIKE A. BRAMLETT, P.E.
 COLORADO P.E. 32314
 FOR AND ON BEHALF OF JR ENGINEERING

THE LOCATIONS OF EXISTING ABOVE GROUND AND UNDERGROUND UTILITIES ARE SHOWN IN AN APPROXIMATE WAY ONLY. THE CONTRACTOR SHALL DETERMINE THE EXACT LOCATION OF ALL EXISTING UTILITIES BEFORE COMMENCING WORK. THE CONTRACTOR SHALL BE FULLY RESPONSIBLE FOR ANY AND ALL DAMAGES WHICH MIGHT BE CAUSED BY HIS FAILURE TO EXACTLY LOCATE AND PRESERVE ANY AND ALL ABOVE GROUND AND UNDERGROUND UTILITIES.

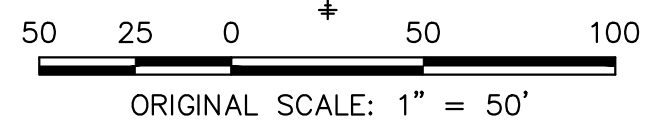

PREPARED FOR	SR LAND, LLC 20 BOULDER CRESCENT SUITE 200 COLORADO SPRINGS, CO 80903 JAMES F. MORLEY (719) 471-1742	
	 J.R. ENGINEERING A Westman Company Centennial 303-740-8888 • Colorado Springs 719-583-2583 Fort Collins 970-491-9888 • www.jrengineering.com	
BY	DATE	
No.	REVISION	
H-SCALE	1"=50'	
V-SCALE	N/A	
DATE	11/10/22	
DESIGNED BY	GAG	
DRAWN BY	GAG	
CHECKED BY		
HOMESTEAD NORTH AT STERLING RANCH FILING 2 GEC-FINAL		
SHEET 10 OF 16		
JOB NO. 25188.10		



LEGEND

KEY	SYMBOL
CHECK DAM (INTERIM/ FINAL)	CD
CONCRETE WASHOUT AREA (INITIAL)	CWA
DIVERSION DITCH AND DIKE, TEMPORARY (INTERIM/ FINAL)	DD
DIVERSION CHANNEL, TEMPORARY (INTERIM/ FINAL)	DV
EROSION CONTROL BLANKET (FINAL)	ECB
INLET PROTECTION (INITIAL/ INTERIM)	IP
LIMITS OF CONSTRUCTION/DISTURBANCE	LOD
OUTLET PROTECTION (INITIAL/ INTERIM)	OP
PERMANENT SEEDING (FINAL)	PS
FLOW ARROW	→
SEDIMENT CONTROL LOG (INITIAL/ INTERIM)	SCL
CUT/FILL MARK	C/F
SILT FENCE (INITIAL)	SF
CONSTRUCTION FENCE	CF
STABILIZED STAGING AREA (INITIAL)	SSA
TEMPORARY SEEDING & MULCHING (FINAL)	MU/TS
VEHICLE TRACKING CONTROL (INITIAL)	VTC
SEDIMENT BASIN (INITIAL)	SB
TEMP. STOCK PILE (INITIAL)	TSP
TEMP. SLOPE DRAIN (INITIAL)	TSD

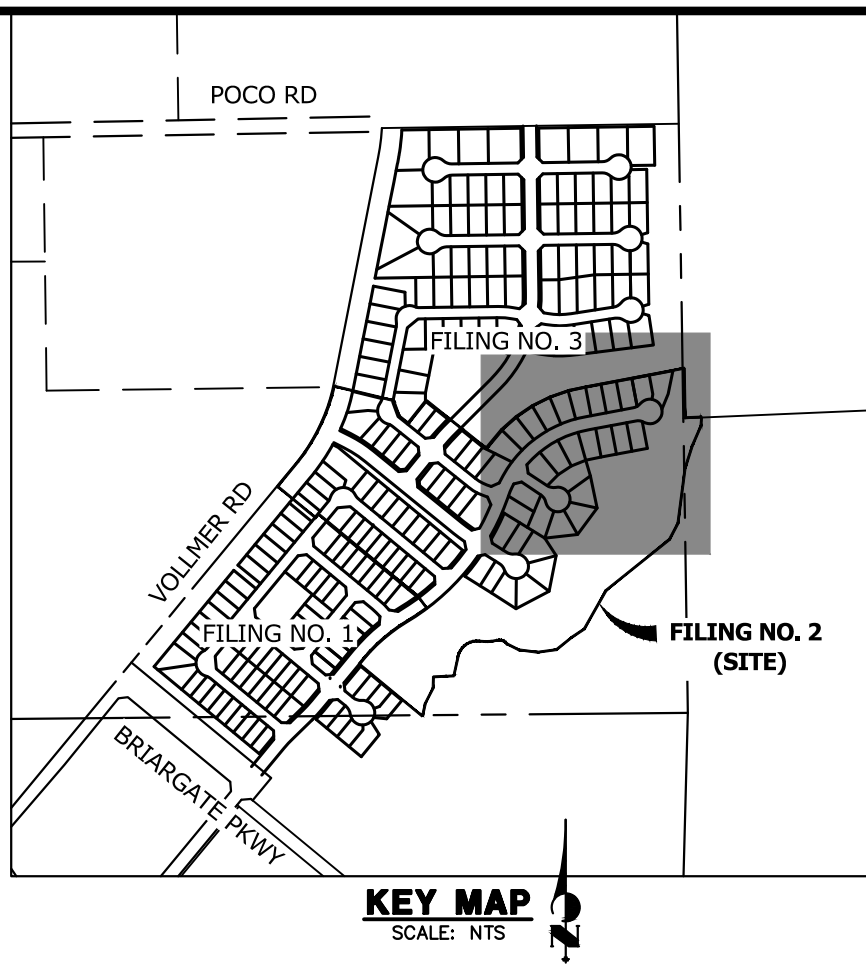

EARTHWORK TOTALS

CUT: 87,785 CY
 FILL: 77,152 CY
 NET: 10,633 CY <CUT>

GRADING, EROSION, AND STORMWATER QUALITY CONTROL PLAN NOTES

- EXISTING VEGETATION ON THE PROJECT SITE CONSISTS OF SPARSE GRASS.
- THE PROPOSED LIMITS OF DISTURBANCE IS OUTSIDE OF THE 100-YEAR FLOODPLAIN PER FEMA FIRM MAP NUMBER 08041C0535G, REVISED DECEMBER 7, 2018.
- THERE ARE NO DEDICATED ASPHALT OR CONCRETE BATCH PLANTS PROPOSED AS PART OF THIS PROJECT.
- DEWATERING OPERATIONS ARE NOT ANTICIPATED FOR THIS PROJECT.
- ALL PROPOSED OFF-SITE STORMWATER CONTROL MEASURES ARE UNDER THE DIRECT CONTROL OR OWNERSHIP OF THE OWNER OR OPERATOR FOR THIS DEVELOPMENT.
- ALL SLOPES 3:1 OR GREATER REQUIRE EROSION CONTROL BLANKET.

BMP PHASING

- INITIAL (SPRING 2023):**
- INSTALL VTC
 - INSTALL CWA
 - ESTABLISH SSA
 - INSTALL CONSTRUCTION FENCE
 - INSTALL SILT FENCE
 - INSTALL SEDIMENT BASINS
 - INSTALL TEMPORARY DIVERSION DITCHES AND TEMPORARY SLOPE DRAINS
 - INSTALL CHECK DAMS
- INTERIM (SPRING 2023-SUMMER 2023):**
- MAINTAIN ALL BMP'S
 - INSTALL INLET AND OUTLET PROTECTION
 - INSTALL EROSION CONTROL BLANKETS
- FINAL (FALL 2023):**
- INSTALL MULCH AND PERMANENT SEEDING IN ALL DISTURBED AREAS
 - REMOVE ALL TEMPORARY BMP'S AFTER FINAL STABILIZATION
- FINAL STABILIZATION ANTICIPATED FALL 2023

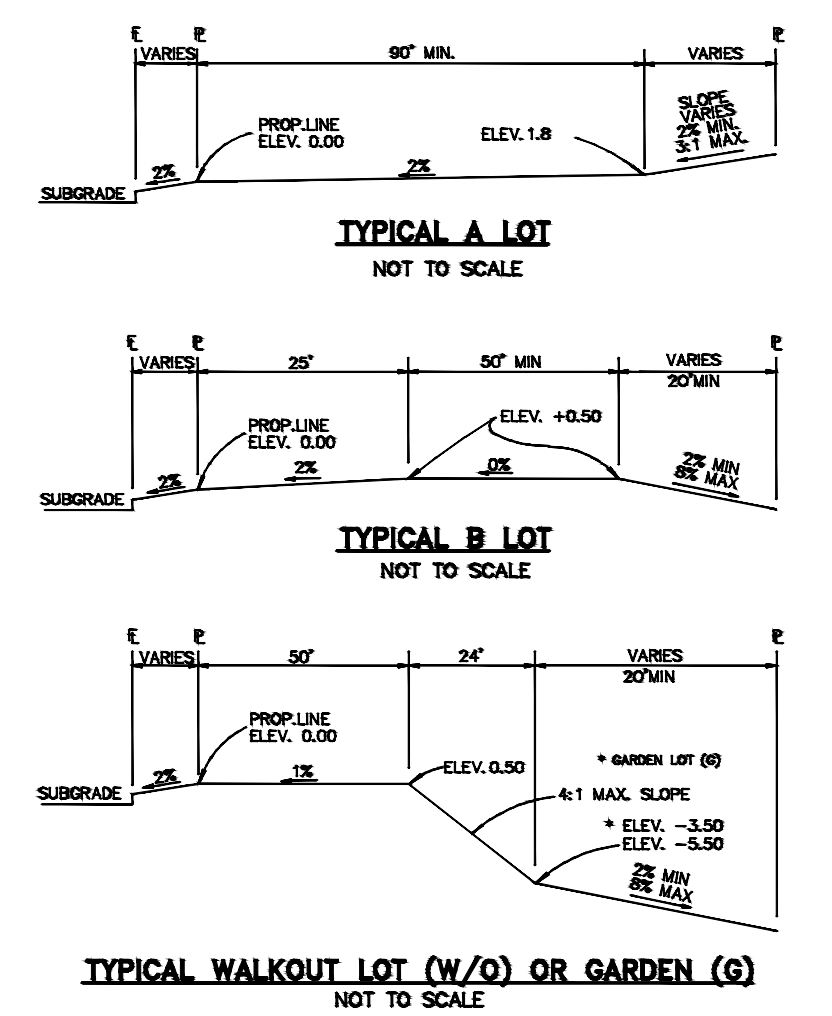

NOTE:
 "T" LOTS OR "TRANSITION" LOTS OCCUR IN PLACES WHERE BOTH PROPERTY LINES CANNOT BE GRADED AS THE TYPICAL STANDARD LOT TEMPLATES SHOWN. THESE LOTS WILL STILL BE GRADED TO CREATE POSITIVE DRAINAGE AWAY FROM THE STRUCTURE.

NOTE:
 SIDE LOT SWALES WILL BE PROVIDED WHEN APPROPRIATE.

ENGINEER'S STATEMENT

THIS GRADING AND EROSION CONTROL PLAN WAS PREPARED UNDER MY DIRECTION AND SUPERVISION AND IS CORRECT TO THE BEST OF MY KNOWLEDGE AND BELIEF. SAID PLAN HAS BEEN PREPARED ACCORDING TO THE CRITERIA ESTABLISHED BY THE COUNTY FOR GRADING AND EROSION CONTROL PLANS. I ACCEPT RESPONSIBILITY FOR ANY LIABILITY CAUSED BY ANY NEGLIGENT ACTS, ERRORS OR OMISSIONS ON MY PART IN PREPARING THIS PLANS.



MIKE A. BRAMLETT, P.E.
 COLORADO P.E. 32314
 FOR AND ON BEHALF OF JR ENGINEERING

THE LOCATIONS OF EXISTING ABOVE GROUND AND UNDERGROUND UTILITIES ARE SHOWN IN AN APPROXIMATE WAY ONLY. THE CONTRACTOR SHALL DETERMINE THE EXACT LOCATION OF ALL EXISTING UTILITIES BEFORE COMMENCING WORK. THE CONTRACTOR SHALL BE FULLY RESPONSIBLE FOR ANY AND ALL DAMAGES WHICH MIGHT BE CAUSED BY HIS FAILURE TO EXACTLY LOCATE AND PRESERVE ANY AND ALL ABOVE GROUND AND UNDERGROUND UTILITIES.

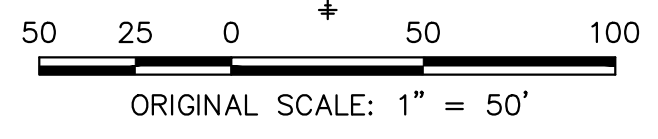

PREPARED FOR	SR LAND, LLC 20 BOULDER CRESCENT SUITE 200 COLORADO SPRINGS, CO 80903 JAMES F. MORLEY (719) 471-1742	
	J.R. ENGINEERING A Westman Company Central 303-740-8888 • Colorado Springs 719-583-2583 Fort Collins 970-491-9888 • www.jrengineering.com	
BY	DATE	
No.	REVISION	
H-SCALE	1"=50'	
V-SCALE	N/A	
DATE	11/10/22	
DESIGNED BY	GAG	
DRAWN BY	GAG	
CHECKED BY		
HOMESTEAD NORTH AT STERLING RANCH FILING 2 GEC-FINAL		
SHEET 11 OF 16		
JOB NO. 25188.10		

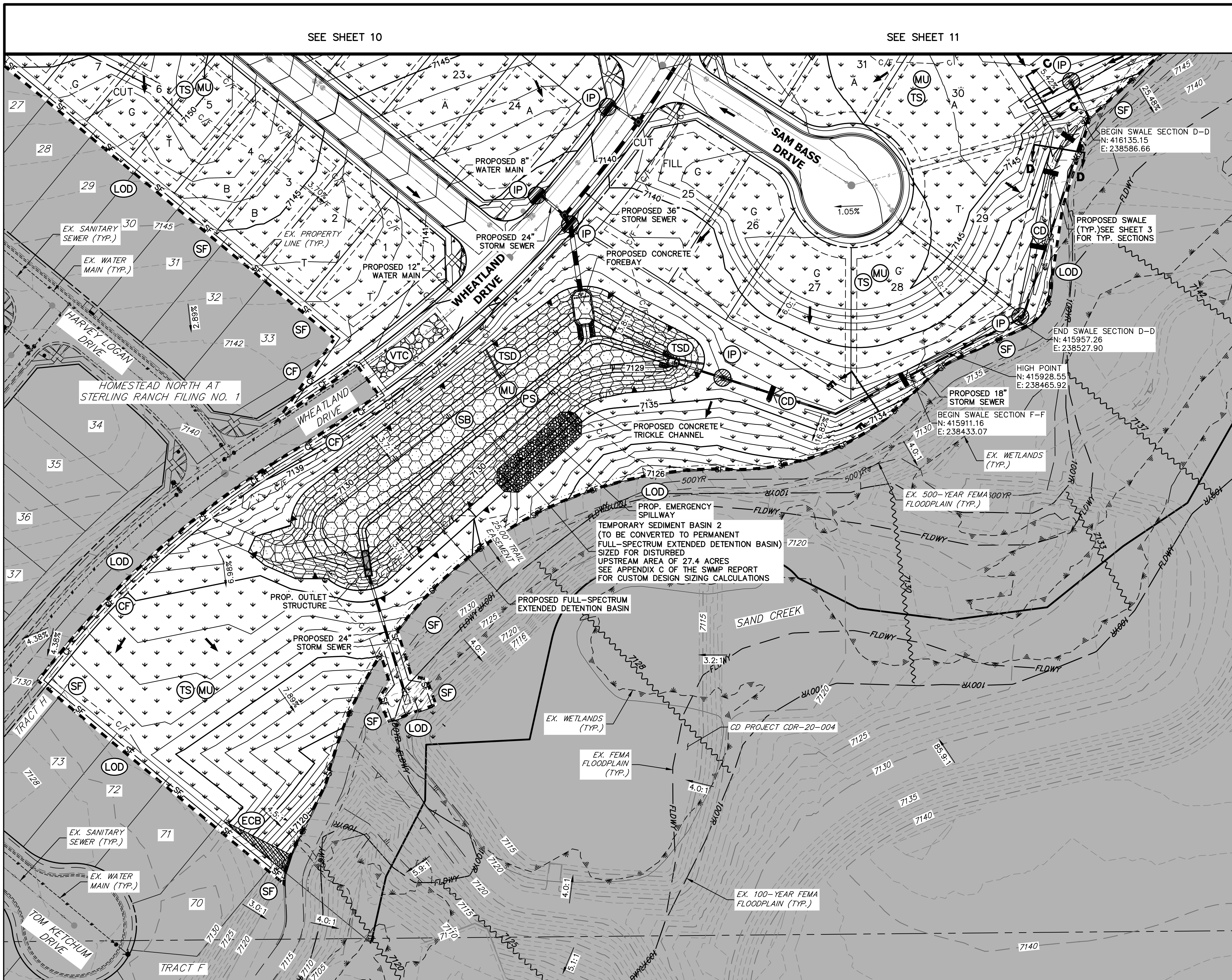

SEE SHEET 10

SEE SHEET 11

LEGEND

KEY	SYMBOL
CHECK DAM (INTERIM/ FINAL)	CD
CONCRETE WASHOUT AREA (INITIAL)	CWA
DIVERSION DITCH AND DIKE, TEMPORARY (INTERIM/ FINAL)	DD
DIVERSION CHANNEL, TEMPORARY (INTERIM/ FINAL)	DV
EROSION CONTROL BLANKET (FINAL)	ECB
INLET PROTECTION (INITIAL/ INTERIM)	IP
LIMITS OF CONSTRUCTION/DISTURBANCE	LOD
OUTLET PROTECTION (INITIAL/ INTERIM)	OP
PERMANENT SEEDING (FINAL)	PS
FLOW ARROW	→
SEDIMENT CONTROL LOG (INITIAL/ INTERIM)	SCL
CUT/FILL MARK	C/F
SILT FENCE (INITIAL)	SF
CONSTRUCTION FENCE	CF
STABILIZED STAGING AREA (INITIAL)	SSA
TEMPORARY SEEDING & MULCHING (FINAL)	MU/TS
VEHICLE TRACKING CONTROL (INITIAL)	VTC
SEDIMENT BASIN (INITIAL)	SB
TEMP. STOCK PILE (INITIAL)	TSP
TEMP. SLOPE DRAIN (INITIAL)	TSD

EARTHWORK TOTALS

CUT: 87,785 CY
 FILL: 77,152 CY
 NET: 10,633 CY <CUT>

GRADING, EROSION, AND STORMWATER QUALITY CONTROL PLAN NOTES

- EXISTING VEGETATION ON THE PROJECT SITE CONSISTS OF SPARSE GRASS.
- THE PROPOSED LIMITS OF DISTURBANCE IS OUTSIDE OF THE 100-YEAR FLOODPLAIN PER FEMA FIRM MAP NUMBER 08041C0535G, REVISED DECEMBER 7, 2018.
- THERE ARE NO DEDICATED ASPHALT OR CONCRETE BATCH PLANTS PROPOSED AS PART OF THIS PROJECT.
- DEWATERING OPERATIONS ARE NOT ANTICIPATED FOR THIS PROJECT.
- ALL PROPOSED OFF-SITE STORMWATER CONTROL MEASURES ARE UNDER THE DIRECT CONTROL OR OWNERSHIP OF THE OWNER OR OPERATOR FOR THIS DEVELOPMENT.
- ALL SLOPES 3:1 OR GREATER REQUIRE EROSION CONTROL BLANKET.

BMP PHASING

- INITIAL (SPRING 2023):**
- INSTALL VTC
 - INSTALL CWA
 - ESTABLISH SSA
 - INSTALL CONSTRUCTION FENCE
 - INSTALL SILT FENCE
 - INSTALL SEDIMENT BASINS
 - INSTALL TEMPORARY DIVERSION DITCHES AND TEMPORARY SLOPE DRAINS
 - INSTALL CHECK DAMS
- INTERIM (SPRING 2023-SUMMER 2023):**
- MAINTAIN ALL BMP'S
 - INSTALL INLET AND OUTLET PROTECTION
 - INSTALL EROSION CONTROL BLANKETS
- FINAL (FALL 2023):**
- INSTALL MULCH AND PERMANENT SEEDING IN ALL DISTURBED AREAS
 - REMOVE ALL TEMPORARY BMP'S AFTER FINAL STABILIZATION
- FINAL STABILIZATION ANTICIPATED FALL 2023

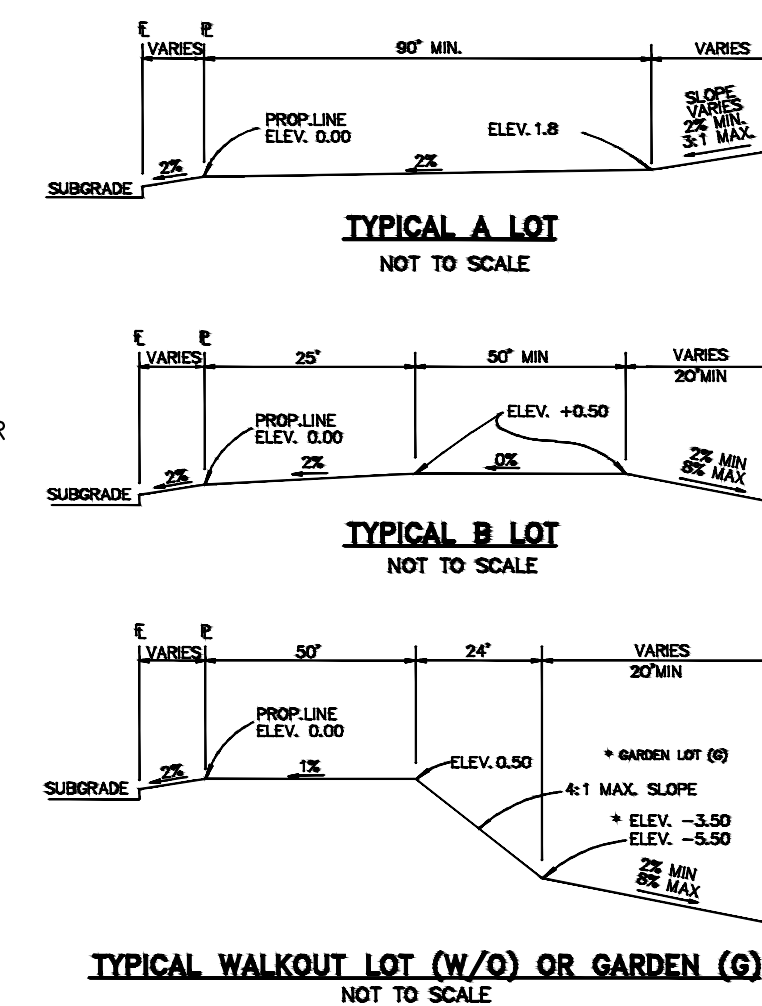

NOTE:
 * TRANSITION * LOTS OCCUR IN PLACES WHERE BOTH PROPERTY LINES CANNOT BE GRADED AS THE TYPICAL STANDARD LOT TEMPLATES SHOWN. THESE LOTS WILL STILL BE GRADED TO CREATE POSITIVE DRAINAGE AWAY FROM THE STRUCTURE.

NOTE:
 SIDE LOT SWALES WILL BE PROVIDED WHEN APPROPRIATE.

ENGINEER'S STATEMENT

THIS GRADING AND EROSION CONTROL PLAN WAS PREPARED UNDER MY DIRECTION AND SUPERVISION AND IS CORRECT TO THE BEST OF MY KNOWLEDGE AND BELIEF. SAID PLAN HAS BEEN PREPARED ACCORDING TO THE CRITERIA ESTABLISHED BY THE COUNTY FOR GRADING AND EROSION CONTROL PLANS. I ACCEPT RESPONSIBILITY FOR ANY LIABILITY CAUSED BY ANY NEGLIGENT ACTS, ERRORS OR OMISSIONS ON MY PART IN PREPARING THIS PLANS.

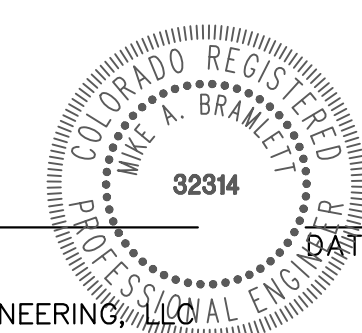

MIKE A. BRAMLETT, P.E.
 COLORADO P.E. 32314
 FOR AND ON BEHALF OF JR ENGINEERING

THE LOCATIONS OF EXISTING ABOVE GROUND AND UNDERGROUND UTILITIES ARE SHOWN IN AN APPROXIMATE WAY ONLY. THE CONTRACTOR SHALL DETERMINE THE EXACT LOCATION OF ALL EXISTING UTILITIES BEFORE COMMENCING WORK. THE CONTRACTOR SHALL BE FULLY RESPONSIBLE FOR ANY AND ALL DAMAGES WHICH MIGHT BE CAUSED BY HIS FAILURE TO EXACTLY LOCATE AND PRESERVE ANY AND ALL ABOVE GROUND AND UNDERGROUND UTILITIES.



Know what's below.
 Call before you dig.

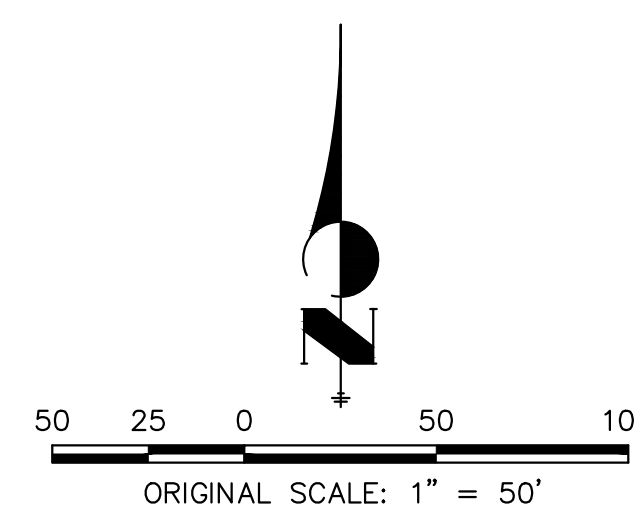

UNTIL SUCH TIME AS THESE DRAWINGS ARE APPROVED BY THE APPROPRIATE REVIEWING AGENCIES, JR ENGINEERING APPROVES THEIR USE. DESIGNATED BY WRITTEN AUTHORIZATION.

PREPARED FOR
SR LAND, LLC
 20 BOULDER CRESCENT
 SUITE 200
 COLORADO SPRINGS, CO 80903
 JAMES F. MORLEY
 (719) 471-1742

J.R. ENGINEERING
 A Westman Company
 Centennial 303-740-9888 • Colorado Springs 719-583-2583
 Fort Collins 970-491-9888 • www.jrengineering.com

BY	DATE	NO.	REVISION

H-SCALE 1"=50'
 V-SCALE N/A
 DATE 11/10/22
 DESIGNED BY GAG
 DRAWN BY GAG
 CHECKED BY

HOMESTEAD NORTH AT STERLING RANCH FILING 2
 GEC-FINAL

SHEET 12 OF 16
 JOB NO. 25188.10

SM-3 Construction Fence (CF)

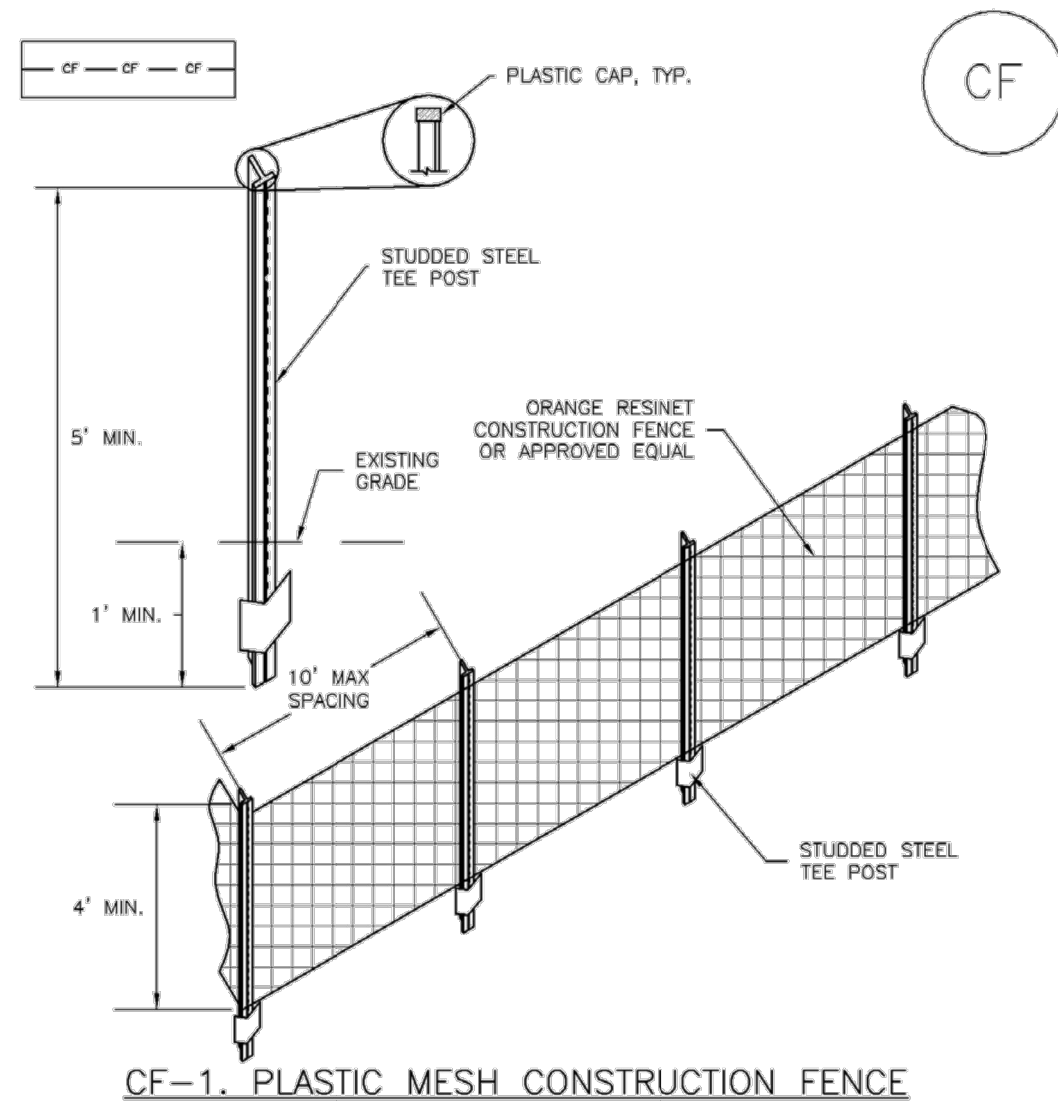

- CF-1. PLASTIC MESH CONSTRUCTION FENCE**
- CONSTRUCTION FENCE INSTALLATION NOTES**
1. SEE PLAN VIEW FOR:
 - LOCATION OF CONSTRUCTION FENCE.
 2. CONSTRUCTION FENCE SHOWN SHALL BE INSTALLED PRIOR TO ANY LAND DISTURBING ACTIVITIES.
 3. CONSTRUCTION FENCE SHALL BE COMPOSED OF ORANGE CONTRACTOR-GRADE MATERIAL THAT IS AT LEAST 4' HIGH. METAL POSTS SHOULD HAVE A PLASTIC CAP FOR SAFETY.
 4. STUDDED STEEL TEE POSTS SHALL BE UTILIZED TO SUPPORT THE CONSTRUCTION FENCE. MAXIMUM SPACING FOR STEEL TEE POSTS SHALL BE 10'.
 5. CONSTRUCTION FENCE SHALL BE SECURELY FASTENED TO THE TOP, MIDDLE, AND BOTTOM OF EACH POST.

CF-2 Urban Drainage and Flood Control District November 2010
 Urban Storm Drainage Criteria Manual Volume 3

Construction Fence (CF) SM-3

- CONSTRUCTION FENCE MAINTENANCE NOTES**
1. INSPECT BMPs EACH WORKDAY, AND MAINTAIN THEM IN EFFECTIVE OPERATING CONDITION. MAINTENANCE OF BMPs SHOULD BE PROACTIVE, NOT REACTIVE. INSPECT BMPs AS SOON AS POSSIBLE (AND ALWAYS WITHIN 24 HOURS) FOLLOWING A STORM THAT CAUSES SURFACE EROSION, AND PERFORM NECESSARY MAINTENANCE.
 2. FREQUENT OBSERVATIONS AND MAINTENANCE ARE NECESSARY TO MAINTAIN BMPs IN EFFECTIVE OPERATING CONDITION. INSPECTIONS AND CORRECTIVE MEASURES SHOULD BE DOCUMENTED THOROUGHLY.
 3. WHERE BMPs HAVE FAILED, REPAIR OR REPLACEMENT SHOULD BE INITIATED UPON DISCOVERY OF THE FAILURE.
 4. CONSTRUCTION FENCE SHALL BE REPAIRED OR REPLACED WHEN THERE ARE SIGNS OF DAMAGE SUCH AS RIPS OR SAGS. CONSTRUCTION FENCE IS TO REMAIN IN PLACE UNTIL THE UPSTREAM DISTURBED AREA IS STABILIZED AND APPROVED BY THE LOCAL JURISDICTION.
 5. WHEN CONSTRUCTION FENCES ARE REMOVED, ALL DISTURBED AREAS ASSOCIATED WITH THE INSTALLATION, MAINTENANCE, AND/OR REMOVAL OF THE FENCE SHALL BE COVERED WITH TOPSOIL, SEEDED AND MULCHED, OR OTHERWISE STABILIZED AS APPROVED BY LOCAL JURISDICTION.
- NOTE: MANY JURISDICTIONS HAVE BMP DETAILS THAT VARY FROM UDFCD STANDARD DETAILS. CONSULT WITH LOCAL JURISDICTIONS AS TO WHICH DETAIL SHOULD BE USED WHEN DIFFERENCES ARE NOTED.**
- (DETAIL ADAPTED FROM TOWN OF PARKER, COLORADO, NOT AVAILABLE IN AUTOCAD)

November 2010 Urban Drainage and Flood Control District November 2010
 Urban Storm Drainage Criteria Manual Volume 3 CF-3

Temporary Slope Drains (TSD) EC-7

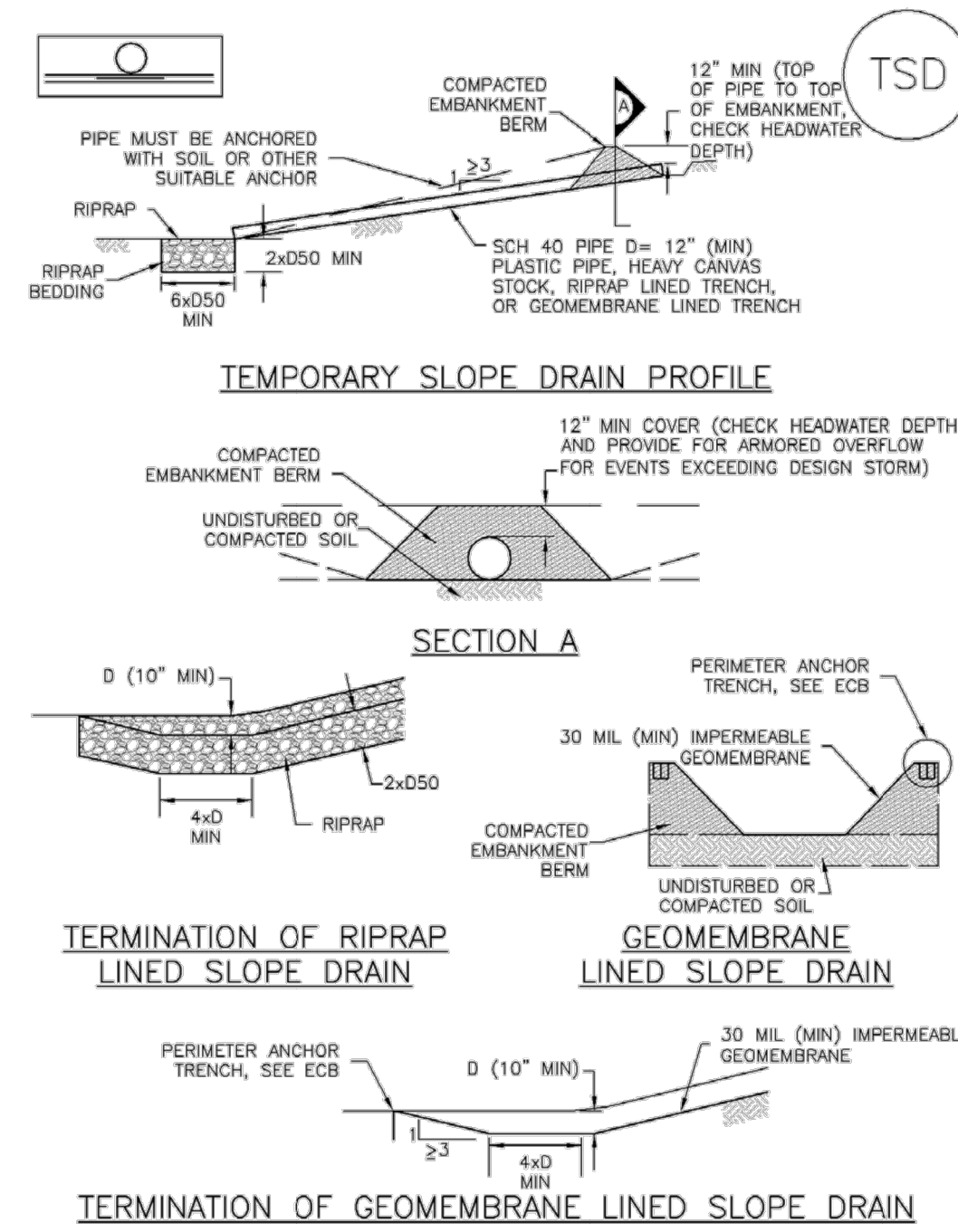

November 2010 Urban Drainage and Flood Control District November 2010
 Urban Storm Drainage Criteria Manual Volume 3 SD-3

EC-7 Temporary Slope Drains (TSD)

- SLOPE DRAIN INSTALLATION NOTES**
1. SEE PLAN VIEW FOR:
 - LOCATION AND LENGTH OF SLOPE DRAIN
 - PIPE DIAMETER, D, AND RIPRAP SIZE, D50.
 2. SLOPE DRAIN SHALL BE DESIGNED TO CONVEY PEAK RUNOFF FOR 2-YEAR 24-HOUR STORM AT A MINIMUM. FOR LONGER DURATION PROJECTS, LARGER MAY BE APPROPRIATE.
 3. SLOPE DRAIN DIMENSIONS SHALL BE CONSIDERED MINIMUM DIMENSIONS; CONTRACTOR MAY ELECT TO INSTALL LARGER FACILITIES.
 4. SLOPE DRAINS INDICATED SHALL BE INSTALLED PRIOR TO UPGRADING LAND-DISTURBING ACTIVITIES.
 5. CHECK HEADWATER DEPTHS FOR TEMPORARY AND PERMANENT SLOPE DRAINS. DETAILS SHOW MINIMUM COVER; INCREASE AS NECESSARY FOR DESIGN HEADWATER DEPTH.
 6. RIPRAP PAD SHALL BE PLACED AT SLOPE DRAIN OUTFALL.
 7. ANCHOR PIPE WITH COVERING WITH SOIL OR AN ALTERNATE SUITABLE ANCHOR MATERIAL.
- SLOPE DRAIN MAINTENANCE NOTES**
1. INSPECT BMPs EACH WORKDAY, AND MAINTAIN THEM IN EFFECTIVE OPERATING CONDITION. MAINTENANCE OF BMPs SHOULD BE PROACTIVE, NOT REACTIVE. INSPECT BMPs AS SOON AS POSSIBLE (AND ALWAYS WITHIN 24 HOURS) FOLLOWING A STORM THAT CAUSES SURFACE EROSION, AND PERFORM NECESSARY MAINTENANCE.
 2. FREQUENT OBSERVATIONS AND MAINTENANCE ARE NECESSARY TO MAINTAIN BMPs IN EFFECTIVE OPERATING CONDITION. INSPECTIONS AND CORRECTIVE MEASURES SHOULD BE DOCUMENTED THOROUGHLY.
 3. WHERE BMPs HAVE FAILED, REPAIR OR REPLACEMENT SHOULD BE INITIATED UPON DISCOVERY OF THE FAILURE.
 4. INSPECT INLET AND OUTLET POINTS AFTER STORMS FOR CLOGGING OR EVIDENCE OF OVERTOPPING. BREACHES IN PIPE OR OTHER CONVEYANCE SHALL BE REPAIRED AS SOON AS PRACTICABLE IF OBSERVED.
 5. INSPECT RIPRAP PAD AT OUTLET FOR SIGNS OF EROSION. IF SIGNS OF EROSION EXIST, ADDITIONAL ARMORING SHALL BE INSTALLED.
 6. TEMPORARY SLOPE DRAINS ARE TO REMAIN IN PLACE UNTIL NO LONGER NEEDED, BUT SHALL BE REMOVED PRIOR TO THE END OF CONSTRUCTION. WHEN SLOPE DRAINS ARE REMOVED, THE DISTURBED AREA SHALL BE COVERED WITH TOP SOIL, SEEDED, MULCHED OR OTHERWISE STABILIZED IN A MANNER APPROVED BY THE LOCAL JURISDICTION.
- NOTE: MANY JURISDICTIONS HAVE BMP DETAILS THAT VARY FROM UDFCD STANDARD DETAILS. CONSULT WITH LOCAL JURISDICTIONS AS TO WHICH DETAIL SHOULD BE USED WHEN DIFFERENCES ARE NOTED.**
- (DETAIL ADAPTED FROM DOUGLAS COUNTY, COLORADO AND THE CITY OF COLORADO SPRINGS, COLORADO, NOT AVAILABLE IN AUTOCAD)

SD-4 Urban Drainage and Flood Control District November 2010
 Urban Storm Drainage Criteria Manual Volume 3

Earth Dikes and Drainage Swales (ED/DS) EC-10

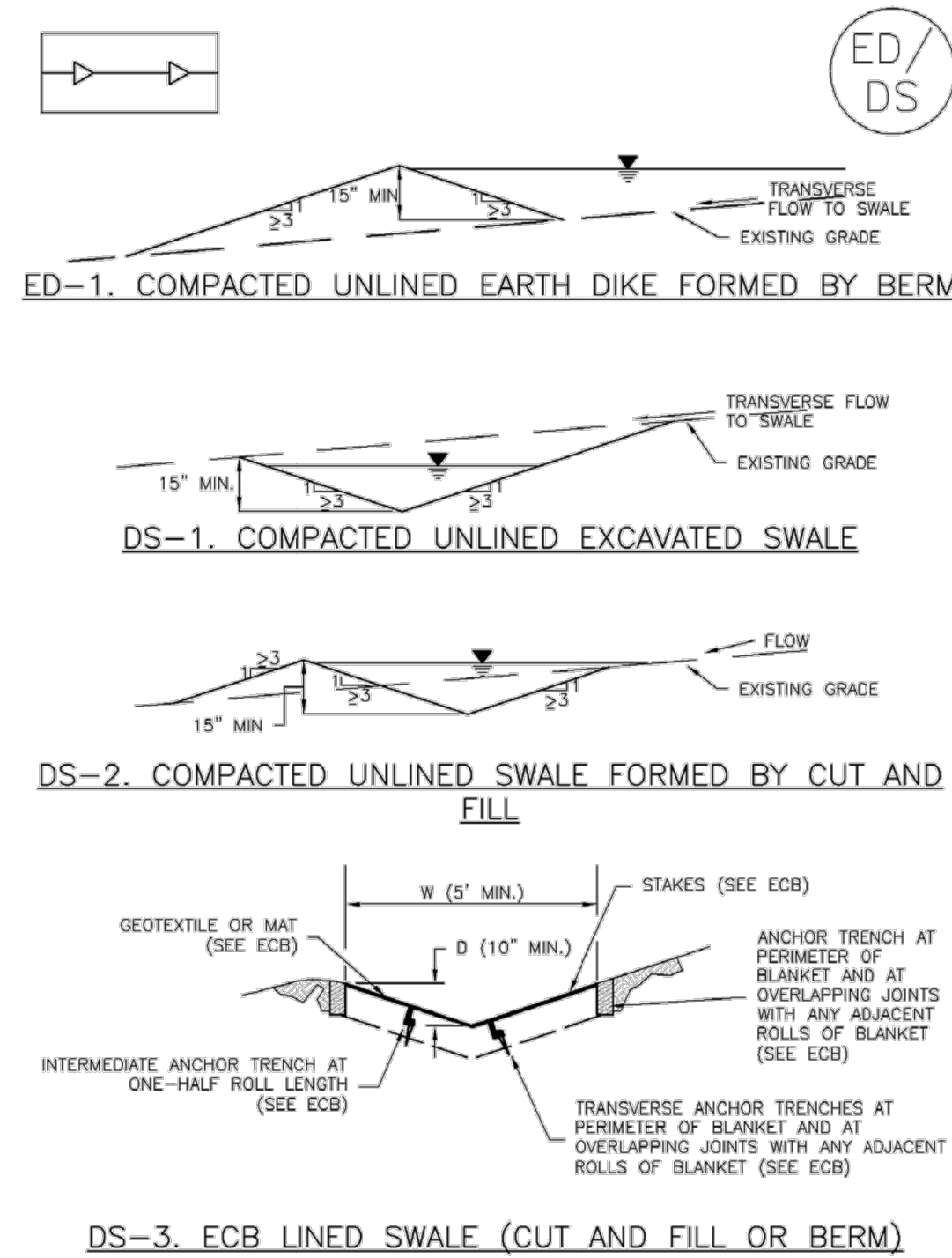

November 2010 Urban Drainage and Flood Control District November 2010
 Urban Storm Drainage Criteria Manual Volume 3 ED/DS-3

EC-10 Earth Dikes and Drainage Swales (ED/DS)

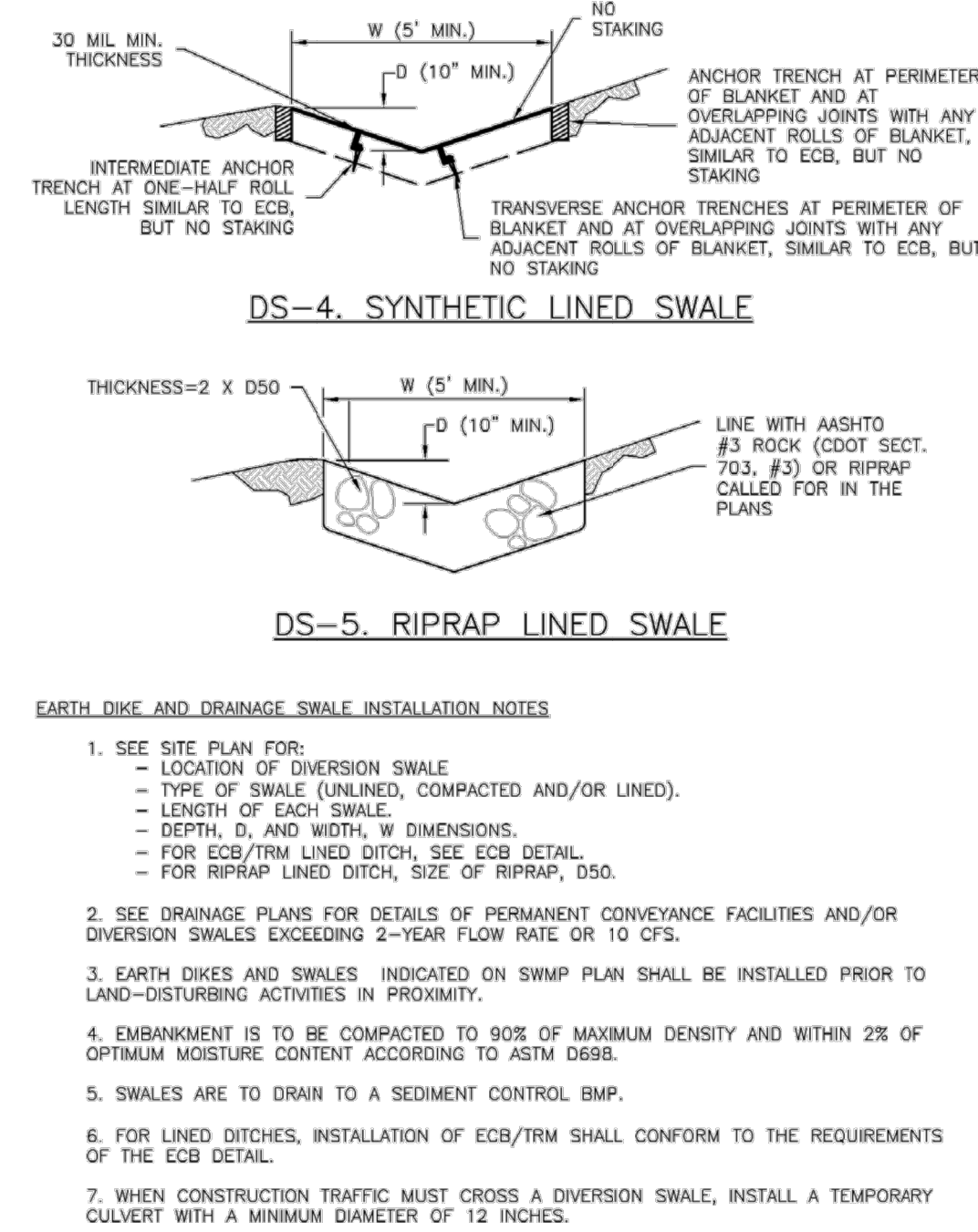

ED/DS-4 Urban Drainage and Flood Control District November 2010
 Urban Storm Drainage Criteria Manual Volume 3

Earth Dikes and Drainage Swales (ED/DS) EC-10

- EARTH DIKE AND DRAINAGE SWALE MAINTENANCE NOTES**
1. INSPECT BMPs EACH WORKDAY, AND MAINTAIN THEM IN EFFECTIVE OPERATING CONDITION. MAINTENANCE OF BMPs SHOULD BE PROACTIVE, NOT REACTIVE. INSPECT BMPs AS SOON AS POSSIBLE (AND ALWAYS WITHIN 24 HOURS) FOLLOWING A STORM THAT CAUSES SURFACE EROSION, AND PERFORM NECESSARY MAINTENANCE.
 2. FREQUENT OBSERVATIONS AND MAINTENANCE ARE NECESSARY TO MAINTAIN BMPs IN EFFECTIVE OPERATING CONDITION. INSPECTIONS AND CORRECTIVE MEASURES SHOULD BE DOCUMENTED THOROUGHLY.
 3. WHERE BMPs HAVE FAILED, REPAIR OR REPLACEMENT SHOULD BE INITIATED UPON DISCOVERY OF THE FAILURE.
 4. SWALES SHALL REMAIN IN PLACE UNTIL THE END OF CONSTRUCTION; IF APPROVED BY LOCAL JURISDICTION, SWALES MAY BE LEFT IN PLACE.
 5. WHEN A SWALE IS REMOVED, THE DISTURBED AREA SHALL BE COVERED WITH TOPSOIL, SEEDED AND MULCHED OR OTHERWISE STABILIZED IN A MANNER APPROVED BY LOCAL JURISDICTION.
- NOTE: MANY JURISDICTIONS HAVE BMP DETAILS THAT VARY FROM UDFCD STANDARD DETAILS. CONSULT WITH LOCAL JURISDICTIONS AS TO WHICH DETAIL SHOULD BE USED WHEN DIFFERENCES ARE NOTED.**
- (DETAIL ADAPTED FROM DOUGLAS COUNTY, COLORADO AND THE CITY OF COLORADO SPRINGS, COLORADO, NOT AVAILABLE IN AUTOCAD)

November 2010 Urban Drainage and Flood Control District November 2010
 Urban Storm Drainage Criteria Manual Volume 3 ED/DS-5

Sediment Basin (SB) SC-7

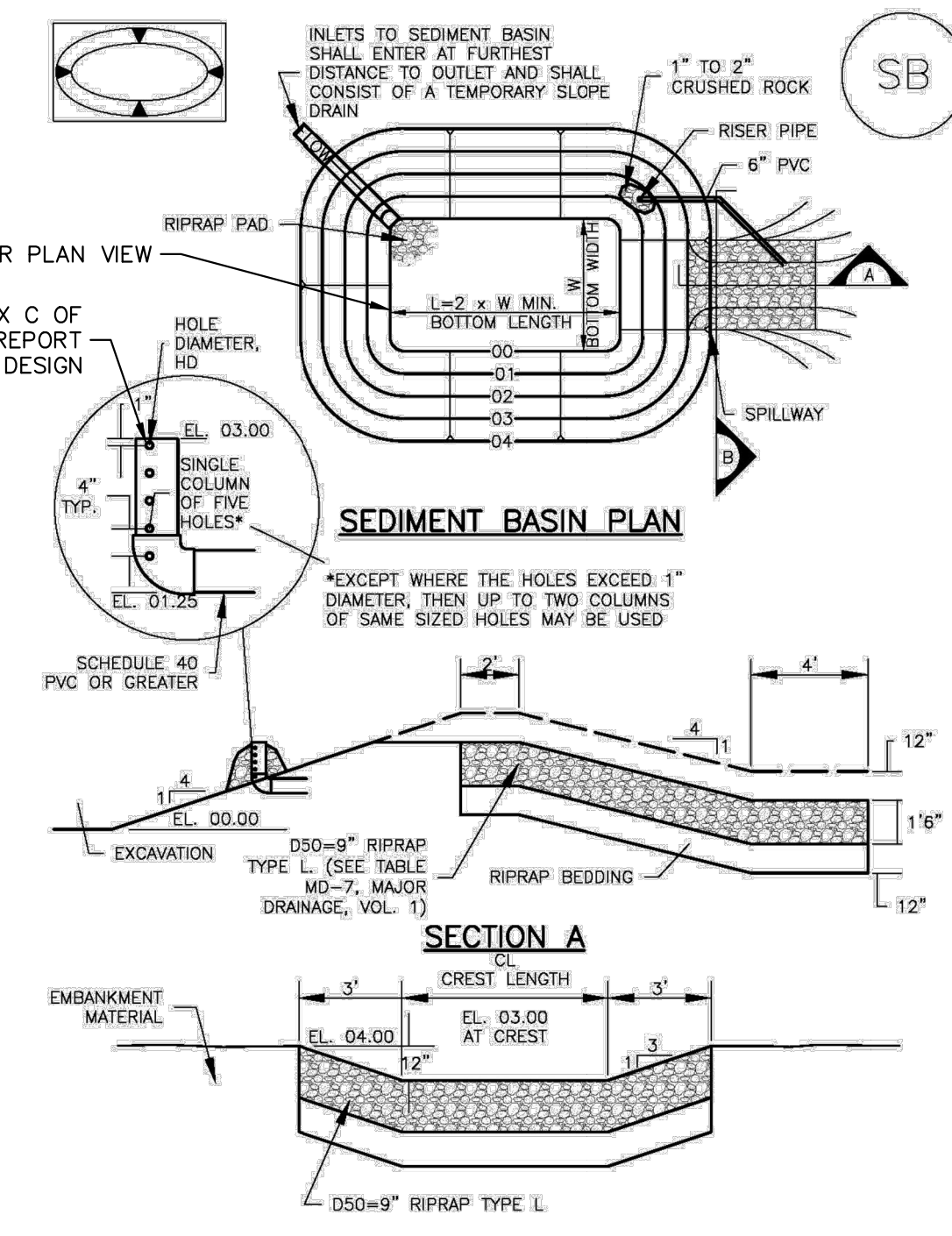

August 2013 Urban Drainage and Flood Control District August 2013
 Urban Storm Drainage Criteria Manual Volume 3 SB-5

UNTIL SUCH TIME AS THESE DRAWINGS ARE APPROVED BY THE AGENCIES, OR ENGINEERING APPROVES THEIR USE, THESE DRAWINGS ARE DESIGNATED BY WRITTEN AUTHORIZATION.
 PREPARED FOR
SR LAND, LLC
 20 BOULDER CRESCENT
 SUITE 200
 COLORADO SPRINGS, CO 80903
 JAMES F. MORLEY
 (719) 471-1742
J.R. ENGINEERING
 A Westman Company
 Centennial 303-740-9888 • Colorado Springs 719-583-2583
 Fort Collins 970-491-9888 • www.jrengineering.com

BY	DATE

No.	REVISION

H-SCALE	N/A	V-SCALE	N/A	DATE	DESIGNED BY	DRAWN BY	CHECKED BY
				11/10/22	GAG	GAG	

811
Know what's below. Call before you dig.

ENGINEER'S STATEMENT
 STANDARD DETAILS SHOWN WERE REVIEWED ONLY AS TO THEIR APPLICATION ON THIS PROJECT

MIKE A. BRAMLETT, P.E.
 COLORADO P.E. 32314
 FOR AND ON BEHALF OF JR ENGINEERING

HOMETEAD NORTH AT STERLING RANCH FILING 2
 DETAILS
 SHEET 14 OF 16
 JOB NO. 25188.10

X:\2518810\Drawings\Sheet\Drawings\Sheet\Drawings\2518810_DTD1.dwg, Detail 02, 11/9/2022, 4:08:08 PM, CS

TABLE SB-1. SIZING INFORMATION FOR STANDARD SEDIMENT BASIN. Table with columns: Upstream Drainage Area (ac), Basin Bottom Width (ft), Spillway Crest Length (ft), Hole Diameter (in).

- SEDIMENT BASIN INSTALLATION NOTES
1. SEE PLAN VIEW FOR: -LOCATION OF SEDIMENT BASIN. -TYPE OF BASIN (STANDARD BASIN OR NONSTANDARD BASIN). -FOR STANDARD BASIN, BOTTOM WIDTH W, CREST LENGTH CL, AND HOLE DIAMETER, HD. -FOR NONSTANDARD BASIN, SEE CONSTRUCTION DRAWINGS FOR DESIGN OF BASIN INCLUDING RISER HEIGHT H, NUMBER OF COLUMNS N, HOLE DIAMETER HD AND PIPE DIAMETER D.
2. FOR STANDARD BASIN, BOTTOM DIMENSION MAY BE MODIFIED AS LONG AS BOTTOM AREA IS NOT REDUCED.
3. SEDIMENT BASINS SHALL BE INSTALLED PRIOR TO ANY OTHER LAND-DISTURBING ACTIVITY THAT RELIES ON BASINS AS A STORMWATER CONTROL.
4. EMBANKMENT MATERIAL SHALL CONSIST OF SOIL FREE OF DEBRIS, ORGANIC MATERIAL, AND ROCKS OR CONCRETE GREATER THAN 3 INCHES AND SHALL HAVE A MINIMUM OF 15 PERCENT BY WEIGHT PASSING THE NO. 200 SIEVE.
5. EMBANKMENT MATERIAL SHALL BE COMPACTED TO AT LEAST 95 PERCENT OF MAXIMUM DENSITY IN ACCORDANCE WITH ASTM D698.
6. PIPE SCH 40 OR GREATER SHALL BE USED.
7. THE DETAILS SHOWN ON THESE SHEETS PERTAIN TO STANDARD SEDIMENT BASIN(S) FOR DRAINAGE AREAS LESS THAN 15 ACRES. SEE CONSTRUCTION DRAWINGS FOR EMBANKMENT, STORAGE VOLUME, SPILLWAY, OUTLET, AND OUTLET PROTECTION DETAILS FOR ANY SEDIMENT BASIN(S) THAT HAVE BEEN INDIVIDUALLY DESIGNED FOR DRAINAGE AREAS LARGER THAN 15 ACRES.

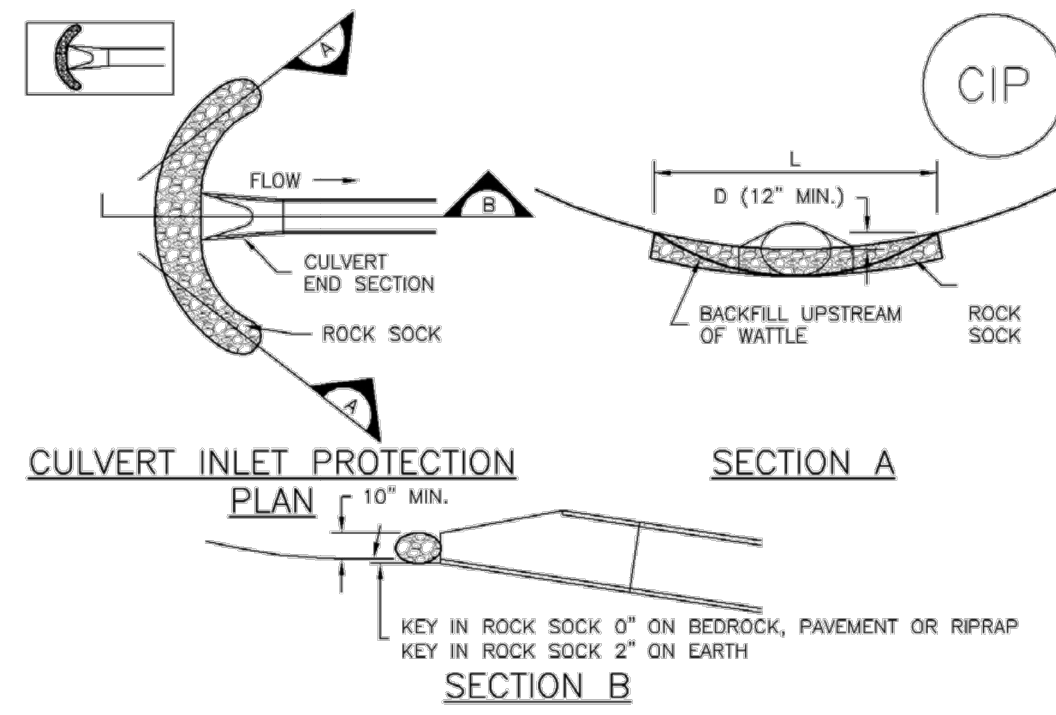

- CIP-1. CULVERT INLET PROTECTION
CULVERT INLET PROTECTION INSTALLATION NOTES
1. SEE PLAN VIEW FOR -LOCATION OF CULVERT INLET PROTECTION.
2. SEE ROCK SOCK DESIGN DETAIL FOR ROCK GRADATION REQUIREMENTS AND JOINTING DETAIL.
CULVERT INLET PROTECTION MAINTENANCE NOTES
1. INSPECT BMPs EACH WORKDAY, AND MAINTAIN THEM IN EFFECTIVE OPERATING CONDITION. MAINTENANCE OF BMPs SHOULD BE PROACTIVE, NOT REACTIVE. INSPECT BMPs AS SOON AS POSSIBLE (AND ALWAYS WITHIN 24 HOURS) FOLLOWING A STORM THAT CAUSES SURFACE EROSION, AND PERFORM NECESSARY MAINTENANCE.
2. FREQUENT OBSERVATIONS AND MAINTENANCE ARE NECESSARY TO MAINTAIN BMPs IN EFFECTIVE OPERATING CONDITION. INSPECTIONS AND CORRECTIVE MEASURES SHOULD BE DOCUMENTED THOROUGHLY.
3. WHERE BMPs HAVE FAILED, REPAIR OR REPLACEMENT SHOULD BE INITIATED UPON DISCOVERY OF THE FAILURE.
4. SEDIMENT ACCUMULATED UPSTREAM OF THE CULVERT SHALL BE REMOVED WHEN THE SEDIMENT DEPTH IS 1/2 THE HEIGHT OF THE ROCK SOCK.
5. CULVERT INLET PROTECTION SHALL REMAIN IN PLACE UNTIL THE UPSTREAM DISTURBED AREA IS PERMANENTLY STABILIZED AND APPROVED BY THE LOCAL JURISDICTION.
(Details adapted from AURORA, COLORADO, NOT AVAILABLE IN AUTOCAD)
NOTE: MANY JURISDICTIONS HAVE BMP DETAILS THAT VARY FROM UDFCD STANDARD DETAILS. CONSULT WITH LOCAL JURISDICTIONS AS TO WHICH DETAIL SHOULD BE USED WHEN DIFFERENCES ARE NOTED.

- SEDIMENT BASIN MAINTENANCE NOTES
1. INSPECT BMPs EACH WORKDAY, AND MAINTAIN THEM IN EFFECTIVE OPERATING CONDITION. MAINTENANCE OF BMPs SHOULD BE PROACTIVE, NOT REACTIVE. INSPECT BMPs AS SOON AS POSSIBLE (AND ALWAYS WITHIN 24 HOURS) FOLLOWING A STORM THAT CAUSES SURFACE EROSION, AND PERFORM NECESSARY MAINTENANCE.
2. FREQUENT OBSERVATIONS AND MAINTENANCE ARE NECESSARY TO MAINTAIN BMPs IN EFFECTIVE OPERATING CONDITION. INSPECTIONS AND CORRECTIVE MEASURES SHOULD BE DOCUMENTED THOROUGHLY.
3. WHERE BMPs HAVE FAILED, REPAIR OR REPLACEMENT SHOULD BE INITIATED UPON DISCOVERY OF THE FAILURE.
4. SEDIMENT ACCUMULATED IN BASIN SHALL BE REMOVED AS NEEDED TO MAINTAIN BMP EFFECTIVENESS. TYPICALLY WHEN SEDIMENT DEPTH REACHES ONE FOOT (I.E., TWO FEET BELOW THE SPILLWAY CREST).
5. SEDIMENT BASINS ARE TO REMAIN IN PLACE UNTIL THE UPSTREAM DISTURBED AREA IS STABILIZED AND GRASS COVER IS ACCEPTED BY THE LOCAL JURISDICTION.
6. WHEN SEDIMENT BASINS ARE REMOVED, ALL DISTURBED AREAS SHALL BE COVERED WITH TOPSOIL, SEEDED AND MULCHED OR OTHERWISE STABILIZED AS APPROVED BY LOCAL JURISDICTION.
(Details adapted from BOULDER COUNTY, COLORADO)
NOTE: MANY JURISDICTIONS HAVE BMP DETAILS THAT VARY FROM UDFCD STANDARD DETAILS. CONSULT WITH LOCAL JURISDICTIONS AS TO WHICH DETAIL SHOULD BE USED WHEN DIFFERENCES ARE NOTED.

- GENERAL INLET PROTECTION INSTALLATION NOTES
1. SEE PLAN VIEW FOR: -LOCATION OF INLET PROTECTION. -TYPE OF INLET PROTECTION (IP-1, IP-2, IP-3, IP-4, IP-5, IP-6)
2. INLET PROTECTION SHALL BE INSTALLED PROMPTLY AFTER INLET CONSTRUCTION OR PAVING IS COMPLETE (TYPICALLY WITHIN 48 HOURS). IF A RAINFALL/RUNOFF EVENT IS FORECAST, INSTALL INLET PROTECTION PRIOR TO ONSET OF EVENT.
3. MANY JURISDICTIONS HAVE BMP DETAILS THAT VARY FROM UDFCD STANDARD DETAILS. CONSULT WITH LOCAL JURISDICTIONS AS TO WHICH DETAIL SHOULD BE USED WHEN DIFFERENCES ARE NOTED.
INLET PROTECTION MAINTENANCE NOTES
1. INSPECT BMPs EACH WORKDAY, AND MAINTAIN THEM IN EFFECTIVE OPERATING CONDITION. MAINTENANCE OF BMPs SHOULD BE PROACTIVE, NOT REACTIVE. INSPECT BMPs AS SOON AS POSSIBLE (AND ALWAYS WITHIN 24 HOURS) FOLLOWING A STORM THAT CAUSES SURFACE EROSION, AND PERFORM NECESSARY MAINTENANCE.
2. FREQUENT OBSERVATIONS AND MAINTENANCE ARE NECESSARY TO MAINTAIN BMPs IN EFFECTIVE OPERATING CONDITION. INSPECTIONS AND CORRECTIVE MEASURES SHOULD BE DOCUMENTED THOROUGHLY.
3. WHERE BMPs HAVE FAILED, REPAIR OR REPLACEMENT SHOULD BE INITIATED UPON DISCOVERY OF THE FAILURE.
4. SEDIMENT ACCUMULATED UPSTREAM OF INLET PROTECTION SHALL BE REMOVED AS NECESSARY TO MAINTAIN BMP EFFECTIVENESS. TYPICALLY WHEN STORAGE VOLUME REACHES 50% OF CAPACITY, A DEPTH OF 6" WHEN SILT FENCE IS USED, OR 1/4 OF THE HEIGHT FOR STRAW BALES.
5. INLET PROTECTION IS TO REMAIN IN PLACE UNTIL THE UPSTREAM DISTURBED AREA IS PERMANENTLY STABILIZED, UNLESS THE LOCAL JURISDICTION APPROVES EARLIER REMOVAL OF INLET PROTECTION IN STREETS.
6. WHEN INLET PROTECTION AT AREA INLETS IS REMOVED, THE DISTURBED AREA SHALL BE COVERED WITH TOP SOIL, SEEDED AND MULCHED, OR OTHERWISE STABILIZED IN A MANNER APPROVED BY THE LOCAL JURISDICTION.
(Details adapted from TOWN OF PARKER, COLORADO AND CITY OF AURORA, COLORADO, NOT AVAILABLE IN AUTOCAD)
NOTE: MANY JURISDICTIONS HAVE BMP DETAILS THAT VARY FROM UDFCD STANDARD DETAILS. CONSULT WITH LOCAL JURISDICTIONS AS TO WHICH DETAIL SHOULD BE USED WHEN DIFFERENCES ARE NOTED.
NOTE: THE DETAILS INCLUDED WITH THIS FACT SHEET SHOW COMMONLY USED, CONVENTIONAL METHODS OF INLET PROTECTION IN THE DENVER METROPOLITAN AREA. THERE ARE MANY PROPRIETARY INLET PROTECTION METHODS ON THE MARKET. UDFCD NEITHER ENDORSES NOR DISCOURAGES USE OF PROPRIETARY INLET PROTECTION; HOWEVER, IN THE EVENT PROPRIETARY METHODS ARE USED, THE APPROPRIATE DETAIL FROM THE MANUFACTURER MUST BE INCLUDED IN THE BMP AND THE BMP MUST BE INSTALLED AND MAINTAINED AS SHOWN IN THE MANUFACTURER'S DETAILS.
NOTE: SOME MUNICIPALITIES DISCOURAGE OR PROHIBIT THE USE OF STRAW BALES FOR INLET PROTECTION. CHECK WITH LOCAL JURISDICTION TO DETERMINE IF STRAW BALE INLET PROTECTION IS ACCEPTABLE.

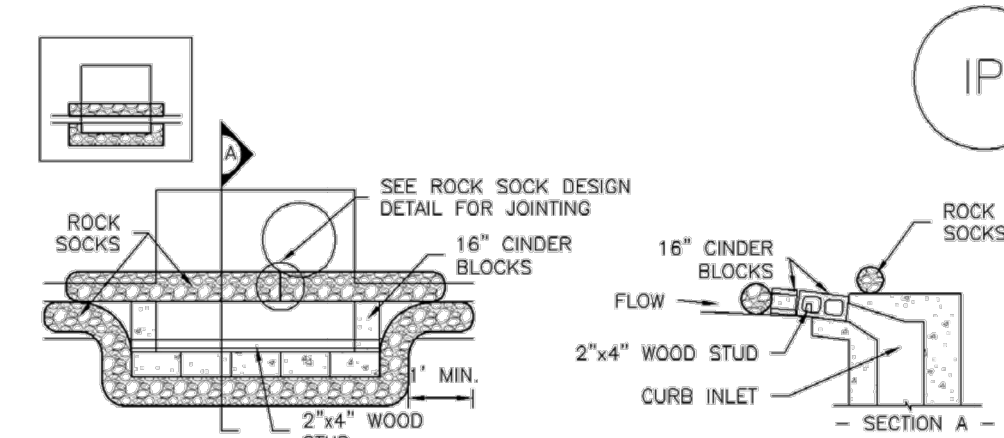

IP-1. BLOCK AND ROCK SOCK SUMP OR ON GRADE INLET PROTECTION

- BLOCK AND CURB SOCK INLET PROTECTION INSTALLATION NOTES
1. SEE ROCK SOCK DESIGN DETAIL FOR INSTALLATION REQUIREMENTS.
2. CONCRETE "CINDER" BLOCKS SHALL BE LAID ON THEIR SIDES AROUND THE INLET IN A SINGLE ROW, ABUTTING ONE ANOTHER WITH THE OPEN END FACING AWAY FROM THE CURB.
3. GRAVEL BAGS SHALL BE PLACED AROUND CONCRETE BLOCKS, CLOSELY ABUTTING ONE ANOTHER AND JOINTED TOGETHER IN ACCORDANCE WITH ROCK SOCK DESIGN DETAIL.
IP-2. CURB ROCK SOCKS UPSTREAM OF INLET PROTECTION
CURB ROCK SOCK INLET PROTECTION INSTALLATION NOTES
1. SEE ROCK SOCK DESIGN DETAIL FOR INSTALLATION REQUIREMENTS.
2. PLACEMENT OF THE SOCK SHALL BE APPROXIMATELY 30 DEGREES FROM PERPENDICULAR IN THE OPPOSITE DIRECTION OF FLOW.
3. SOCKS ARE TO BE FLUSH WITH THE CURB AND SPACED A MINIMUM OF 5 FEET APART.
4. AT LEAST TWO CURB SOCKS IN SERIES ARE REQUIRED UPSTREAM OF ON-GRADE INLETS.

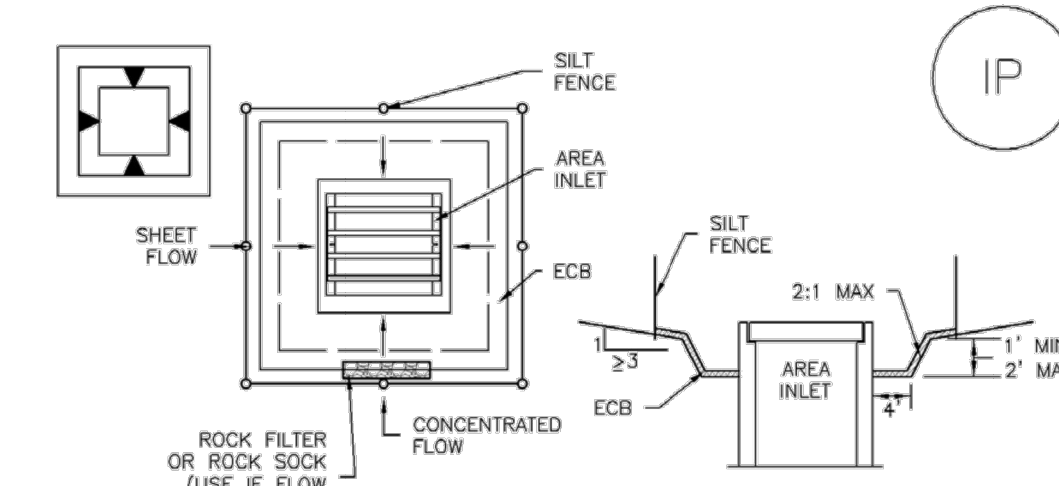
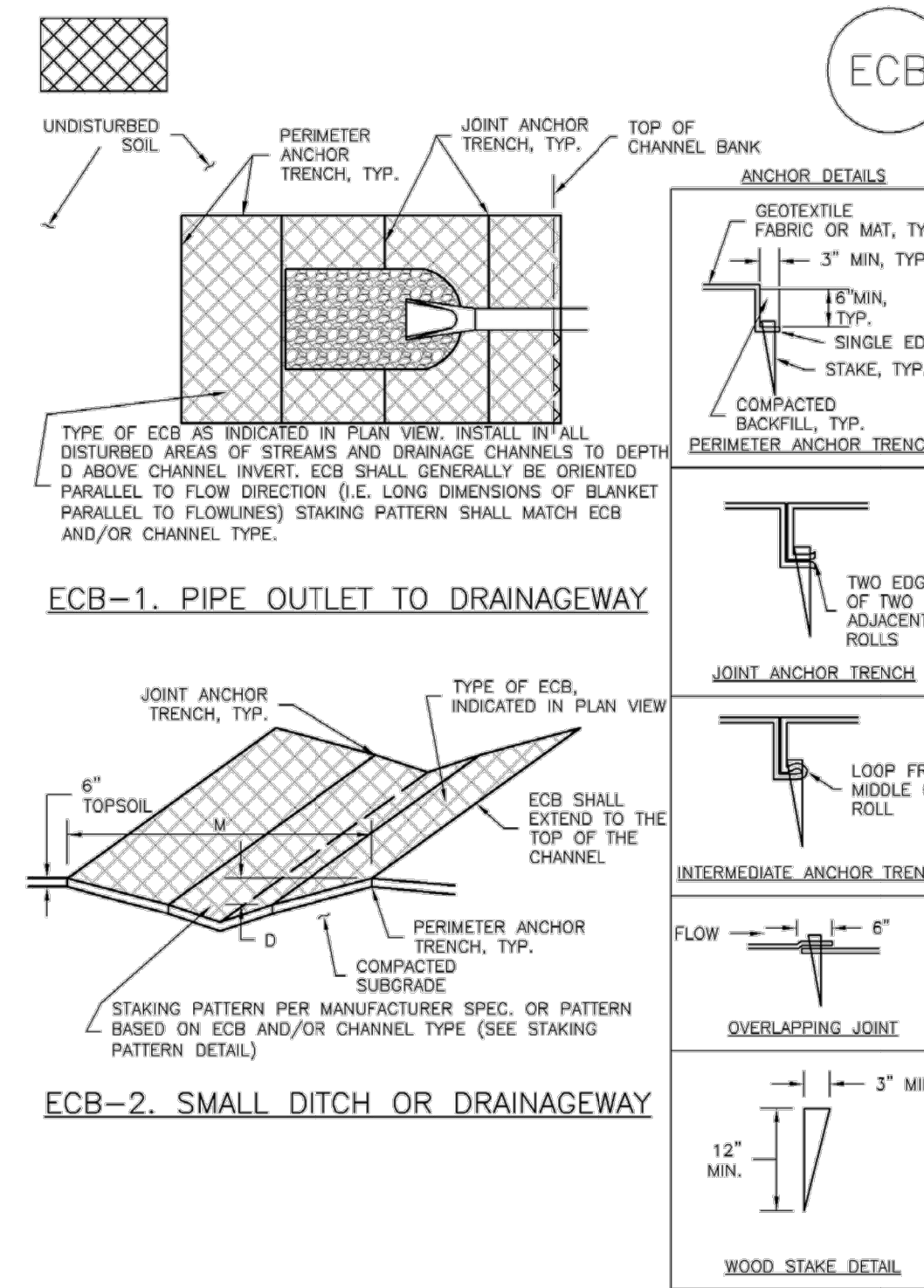

IP-5. OVEREXCAVATION INLET PROTECTION

- OVEREXCAVATION INLET PROTECTION INSTALLATION NOTES
1. THIS FORM OF INLET PROTECTION IS PRIMARILY APPLICABLE FOR SITES THAT HAVE NOT YET REACHED FINAL GRADE AND SHOULD BE USED ONLY FOR INLETS WITH A RELATIVELY SMALL CONTRIBUTING DRAINAGE AREA.
2. WHEN USING FOR CONCENTRATED FLOWS, SHAPE BASIN IN 2:1 RATIO WITH LENGTH ORIENTED TOWARDS DIRECTION OF FLOW.
3. SEDIMENT MUST BE PERIODICALLY REMOVED FROM THE OVEREXCAVATED AREA.

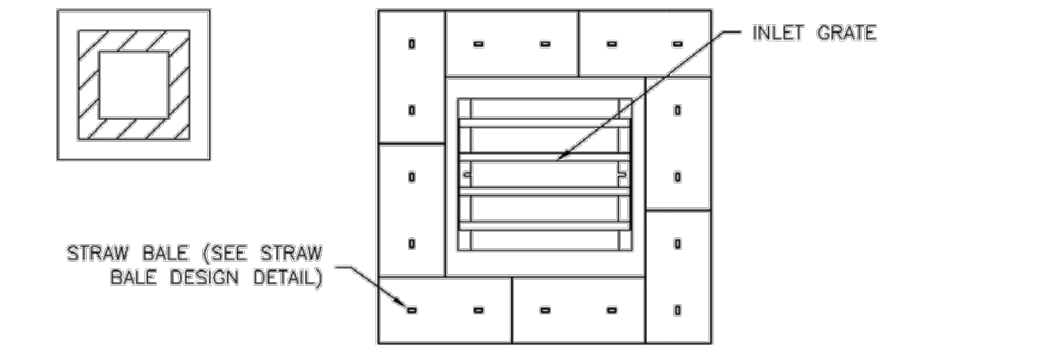

IP-6. STRAW BALE FOR SUMP INLET PROTECTION

- STRAW BALE BARRIER INLET PROTECTION INSTALLATION NOTES
1. SEE STRAW BALE DESIGN DETAIL FOR INSTALLATION REQUIREMENTS.
2. BALES SHALL BE PLACED IN A SINGLE ROW AROUND THE INLET WITH ENDS OF BALES TIGHTLY ABUTTING ONE ANOTHER.

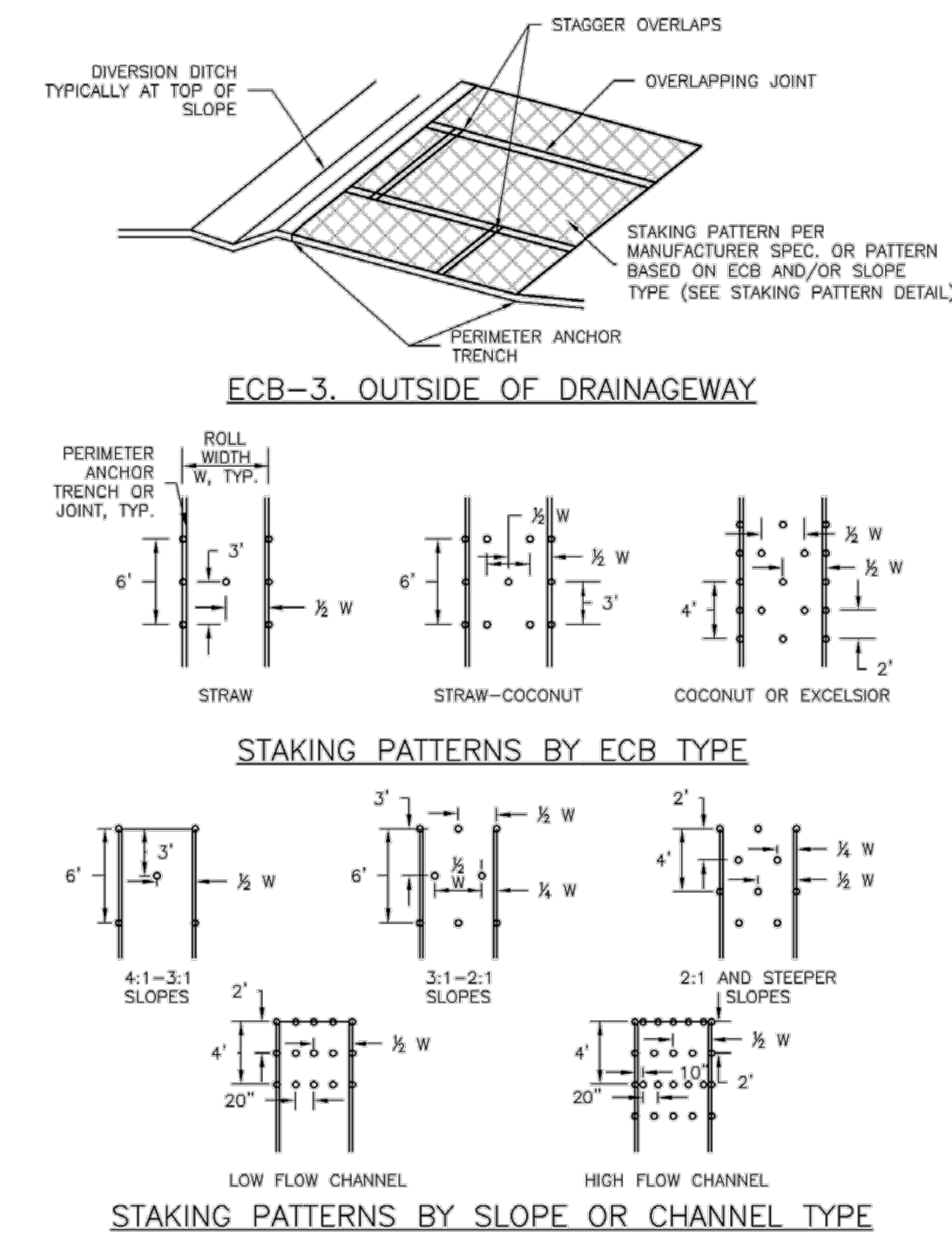

UNTIL SUCH TIME AS THESE DRAWINGS ARE APPROVED BY THE APPROPRIATE REVIEWING AGENCIES, OR ENGINEERING APPROVES THEIR USE, THESE DRAWINGS ARE DESIGNATED BY WRITTEN AUTHORIZATION.

PREPARED FOR SR LAND, LLC 20 BOULDER CRESCENT SUITE 200 COLORADO SPRINGS, CO 80903 JAMES F. MORLEY (719) 471-1742

J.R. ENGINEERING A Westman Company Central 303-740-9383 Colorado Springs 719-583-2583 Fort Collins 970-491-9888 www.jrengineering.com

Table with columns: BY, DATE, No., REVISION.

Table with columns: H-SCALE, V-SCALE, DATE, DESIGNED BY, DRAWN BY, CHECKED BY.

HOMESTEAD NORTH AT STERLING RANCH FILING 2 DETAILS SHEET 15 OF 16 JOB NO. 25188.10



ENGINEER'S STATEMENT STANDARD DETAILS SHOWN WERE REVIEWED ONLY AS TO THEIR APPLICATION ON THIS PROJECT. MIKE A. BRAMLETT, P.E. COLORADO P.E. 32314 FOR AND ON BEHALF OF JR ENGINEERING

EC-6 Rolled Erosion Control Products (RECP)

EROSION CONTROL BLANKET INSTALLATION NOTES

- 1. SEE PLAN VIEW FOR: -LOCATION OF ECB. -TYPE OF ECB (STRAW, STRAW-COCOONUT, COCOONUT, OR EXCELSIOR). -AREA, A, IN SQUARE YARDS OF EACH TYPE OF ECB. 2. 100% NATURAL AND BIODEGRADABLE MATERIALS ARE PREFERRED FOR RECPs, ALTHOUGH SOME JURISDICTIONS MAY ALLOW OTHER MATERIALS IN SOME APPLICATIONS. 3. IN AREAS WHERE ECBs ARE SHOWN ON THE PLANS, THE PERMITTEE SHALL PLACE TOPSOIL AND PERFORM FINAL GRADING, SURFACE PREPARATION, AND SEEDING AND MULCHING. SUBGRADE SHALL BE SMOOTH AND MOIST PRIOR TO ECB INSTALLATION AND THE ECB SHALL BE IN FULL CONTACT WITH SUBGRADE. NO GAPS OR VOIDS SHALL EXIST UNDER THE BLANKET. 4. PERIMETER ANCHOR TRENCH SHALL BE USED ALONG THE OUTSIDE PERIMETER OF ALL BLANKET AREAS. 5. JOINT ANCHOR TRENCH SHALL BE USED TO JOIN ROLLS OF ECBs TOGETHER (LONGITUDINALLY AND TRANSVERSELY) FOR ALL ECBs EXCEPT STRAW WHICH MAY USE AN OVERLAPPING JOINT. 6. INTERMEDIATE ANCHOR TRENCH SHALL BE USED AT SPACING OF ONE-HALF ROLL LENGTH FOR COCONUT AND EXCELSIOR ECBs. 7. OVERLAPPING JOINT DETAIL SHALL BE USED TO JOIN ROLLS OF ECBs TOGETHER FOR ECBs ON SLOPES. 8. MATERIAL SPECIFICATIONS OF ECBs SHALL CONFORM TO TABLE ECB-1. 9. ANY AREAS OF SEEDING AND MULCHING DISTURBED IN THE PROCESS OF INSTALLING ECBs SHALL BE RESEEDED AND MULCHED. 10. DETAILS ON DESIGN PLANS FOR MAJOR DRAINAGEWAY STABILIZATION WILL GOVERN IF DIFFERENT FROM THOSE SHOWN HERE.

TABLE ECB-1. ECB MATERIAL SPECIFICATIONS. Table with columns: TYPE, COCONUT CONTENT, STRAW CONTENT, EXCELSIOR CONTENT, RECOMMENDED NETTING**. Rows include STRAW, COCONUT, COCONUT, and EXCELSIOR.

STRAW ECBs MAY ONLY BE USED OUTSIDE OF STRIPES AND BROADWAY CHANNELS. ALTERNATE NETTING MAY BE ACCEPTABLE IN SOME JURISDICTIONS.

RECP-8 Urban Drainage and Flood Control District Urban Storm Drainage Criteria Manual Volume 3 November 2010

EC-2 Temporary and Permanent Seeding (TS/PS)

Table TS/PS-2. Minimum Drill Seeding Rates for Perennial Grasses

Table with columns: Common Name, Botanical Name, Growth Season, Growth Form, Seeds/Pound, Pounds of PLS/acre. Lists various grass species like Alkali sacaton, Basin wildrye, Sodar streambank wheatgrass, etc.

TS/PS-4 Urban Drainage and Flood Control District Urban Storm Drainage Criteria Manual Volume 3 June 2012

Roller Erosion Control Products (RECP) EC-6

EROSION CONTROL BLANKET MAINTENANCE NOTES

- 1. INSPECT BMPs EACH WORKDAY, AND MAINTAIN THEM IN EFFECTIVE OPERATING CONDITION. MAINTENANCE OF BMPs SHOULD BE PROACTIVE, NOT REACTIVE. INSPECT BMPs AS SOON AS POSSIBLE (AND ALWAYS WITHIN 24 HOURS) FOLLOWING A STORM THAT CAUSES SURFACE EROSION, AND PERFORM NECESSARY MAINTENANCE. 2. FREQUENT OBSERVATIONS AND MAINTENANCE ARE NECESSARY TO MAINTAIN BMPs IN EFFECTIVE OPERATING CONDITION. INSPECTIONS AND CORRECTIVE MEASURES SHOULD BE DOCUMENTED THOROUGHLY. 3. WHERE BMPs HAVE FAILED, REPAIR OR REPLACEMENT SHOULD BE INITIATED UPON DISCOVERY OF THE FAILURE. 4. ECBs SHALL BE LEFT IN PLACE TO EVENTUALLY BIODEGRADE, UNLESS REQUESTED TO BE REMOVED BY THE LOCAL JURISDICTION. 5. ANY ECB PULLED OUT, TORN, OR OTHERWISE DAMAGED SHALL BE REPAIRED OR REINSTALLED. ANY SUBGRADE AREAS BELOW THE GEOTEXTILE THAT HAVE ERODED TO CREATED A VOID UNDER THE BLANKET, OR THAT REMAIN DEVOID OF GRASS SHALL BE REPAIRED, RESEEDED AND MULCHED AND THE ECB REINSTALLED. NOTE: MANY JURISDICTIONS HAVE BMP DETAILS THAT VARY FROM UDFCD STANDARD DETAILS. CONSULT WITH LOCAL JURISDICTIONS AS TO WHICH DETAIL SHOULD BE USED WHEN DIFFERENCES ARE NOTED. (DETAILS ADAPTED FROM DOUGLAS COUNTY, COLORADO AND TOWN OF PARKER, COLORADO, NOT AVAILABLE IN AUTOCAD)

Stockpile Management (SP) MM-2

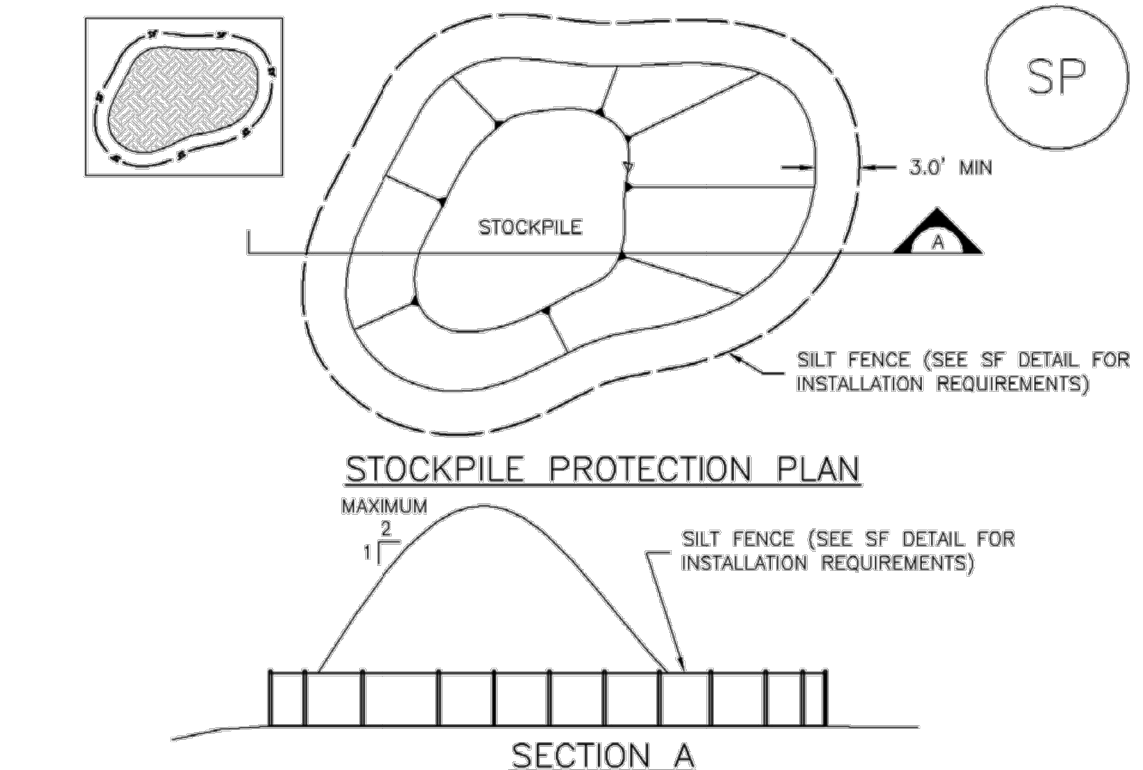

SP-1. STOCKPILE PROTECTION

- 1. SEE PLAN VIEW FOR: -LOCATION OF STOCKPILES. -TYPE OF STOCKPILE PROTECTION. 2. INSTALL PERIMETER CONTROLS IN ACCORDANCE WITH THEIR RESPECTIVE DESIGN DETAILS. SILT FENCE IS SHOWN IN THE STOCKPILE PROTECTION DETAILS; HOWEVER, OTHER TYPES OF PERIMETER CONTROLS INCLUDING SEDIMENT CONTROL LOGS OR ROCK SOCKS MAY BE SUITABLE IN SOME CIRCUMSTANCES. CONSIDERATIONS FOR DETERMINING THE APPROPRIATE TYPE OF PERIMETER CONTROL FOR A STOCKPILE INCLUDE WHETHER THE STOCKPILE IS LOCATED ON A PERVIOUS OR IMPERVIOUS SURFACE, THE RELATIVE HEIGHTS OF THE PERIMETER CONTROL AND STOCKPILE, THE ABILITY OF THE PERIMETER CONTROL TO CONTAIN THE STOCKPILE WITHOUT FAILING IN THE EVENT THAT MATERIAL FROM THE STOCKPILE SHIFTS OR SLUMPS AGAINST THE PERIMETER, AND OTHER FACTORS. 3. STABILIZE THE STOCKPILE SURFACE WITH SURFACE ROUGHENING, TEMPORARY SEEDING AND MULCHING, EROSION CONTROL BLANKETS, OR SOIL BINDERS. SOILS STOCKPILED FOR AN EXTENDED PERIOD (TYPICALLY FOR MORE THAN 60 DAYS) SHOULD BE SEEDED AND MULCHED WITH A TEMPORARY GRASS COVER ONCE THE STOCKPILE IS PLACED (TYPICALLY WITHIN 14 DAYS). USE OF MULCH ONLY OR A SOIL BINDER IS ACCEPTABLE IF THE STOCKPILE WILL BE IN PLACE FOR A MORE LIMITED TIME PERIOD (TYPICALLY 30-60 DAYS). 4. FOR TEMPORARY STOCKPILES ON THE INTERIOR PORTION OF A CONSTRUCTION SITE, WHERE OTHER DOWNGRADIENT CONTROLS, INCLUDING PERIMETER CONTROL, ARE IN PLACE, STOCKPILE PERIMETER CONTROLS MAY NOT BE REQUIRED.

November 2010 Urban Drainage and Flood Control District Urban Storm Drainage Criteria Manual Volume 3 SP-3

EC-2 Temporary and Permanent Seeding (TS/PS)

Table TS/PS-3. Seeding Dates for Annual and Perennial Grasses

Table with columns: Seeding Dates, Annual Grasses (Warm, Cool), Perennial Grasses (Warm, Cool). Lists seeding windows for various grasses.

Mulch: Cover seeded areas with mulch or an appropriate rolled erosion control product to promote establishment of vegetation. Anchor mulch by crimping, netting or use of a non-toxic tackifier. See the Mulching BMP Fact Sheet for additional guidance. Maintenance and Removal: Monitor and observe seeded areas to identify areas of poor growth or areas that fail to germinate. Reseed and mulch these areas, as needed. An area that has been permanently seeded should have a good stand of vegetation within one growing season if irrigated and within three growing seasons without irrigation in Colorado. Reseed portions of the site that fail to germinate or remain bare after the first growing season. Seeded areas may require irrigation, particularly during extended dry periods. Targeted weed control may also be necessary. Protect seeded areas from construction equipment and vehicle access.

TS/PS-6 Urban Drainage and Flood Control District Urban Storm Drainage Criteria Manual Volume 3 June 2012

MM-2 Stockpile Management (SM)

STOCKPILE PROTECTION MAINTENANCE NOTES

- 1. INSPECT BMPs EACH WORKDAY, AND MAINTAIN THEM IN EFFECTIVE OPERATING CONDITION. MAINTENANCE OF BMPs SHOULD BE PROACTIVE, NOT REACTIVE. INSPECT BMPs AS SOON AS POSSIBLE (AND ALWAYS WITHIN 24 HOURS) FOLLOWING A STORM THAT CAUSES SURFACE EROSION, AND PERFORM NECESSARY MAINTENANCE. 2. FREQUENT OBSERVATIONS AND MAINTENANCE ARE NECESSARY TO MAINTAIN BMPs IN EFFECTIVE OPERATING CONDITION. INSPECTIONS AND CORRECTIVE MEASURES SHOULD BE DOCUMENTED THOROUGHLY. 3. WHERE BMPs HAVE FAILED, REPAIR OR REPLACEMENT SHOULD BE INITIATED UPON DISCOVERY OF THE FAILURE. 4. IF PERIMETER PROTECTION MUST BE MOVED TO ACCESS SOIL STOCKPILE, REPLACE PERIMETER CONTROLS BY THE END OF THE WORKDAY. 5. STOCKPILE PERIMETER CONTROLS CAN BE REMOVED ONCE ALL THE MATERIAL FROM THE STOCKPILE HAS BEEN USED. (DETAILS ADAPTED FROM PARKER, COLORADO, NOT AVAILABLE IN AUTOCAD) NOTE: MANY JURISDICTIONS HAVE BMP DETAILS THAT VARY FROM UDFCD STANDARD DETAILS. CONSULT WITH LOCAL JURISDICTIONS AS TO WHICH DETAIL SHOULD BE USED WHEN DIFFERENCES ARE NOTED.

SP-4 Urban Drainage and Flood Control District Urban Storm Drainage Criteria Manual Volume 3 November 2010

MULCHING NOTES: Installation Requirements, Maintenance Requirements. Figure MU-1 Mulching Construction Detail and Maintenance Requirements. City of Colorado Springs Stormwater Quality.



ENGINEER'S STATEMENT: STANDARD DETAILS SHOWN WERE REVIEWED ONLY AS TO THEIR APPLICATION ON THIS PROJECT. MIKE A. BRAMLETT, P.E. COLORADO P.E. 32314 FOR AND ON BEHALF OF JR ENGINEERING.

UNTIL SUCH TIME AS THESE DRAWINGS ARE APPROVED BY THE APPROPRIATE REVIEWING AGENCIES, JR ENGINEERING APPROVES THEIR USE ONLY AS DESIGNATED BY WRITTEN AUTHORIZATION. PREPARED FOR SR LAND, LLC 20 BOULDER CRESCENT SUITE 200 COLORADO SPRINGS, CO 80903 JAMES F. MORLEY (719) 471-1742

Revision table with columns: No., REVISION, DATE.

Designation table with columns: H-SCALE, V-SCALE, DATE, DESIGNED BY, DRAWN BY, CHECKED BY.

HOMESTEAD NORTH AT STERLING RANCH FILING 2 DETAILS SHEET 16 OF 16 JOB NO. 25188.10

DETENTION BASIN STAGE-STORAGE TABLE BUILDER

MHFD-Detention, Version 4.04 (February 2021)

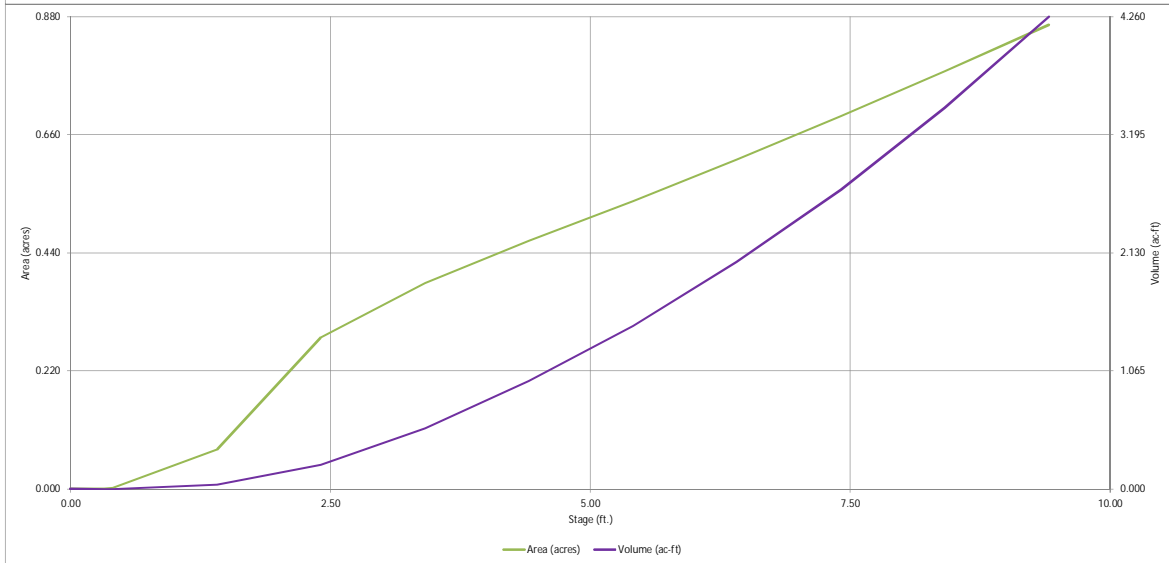
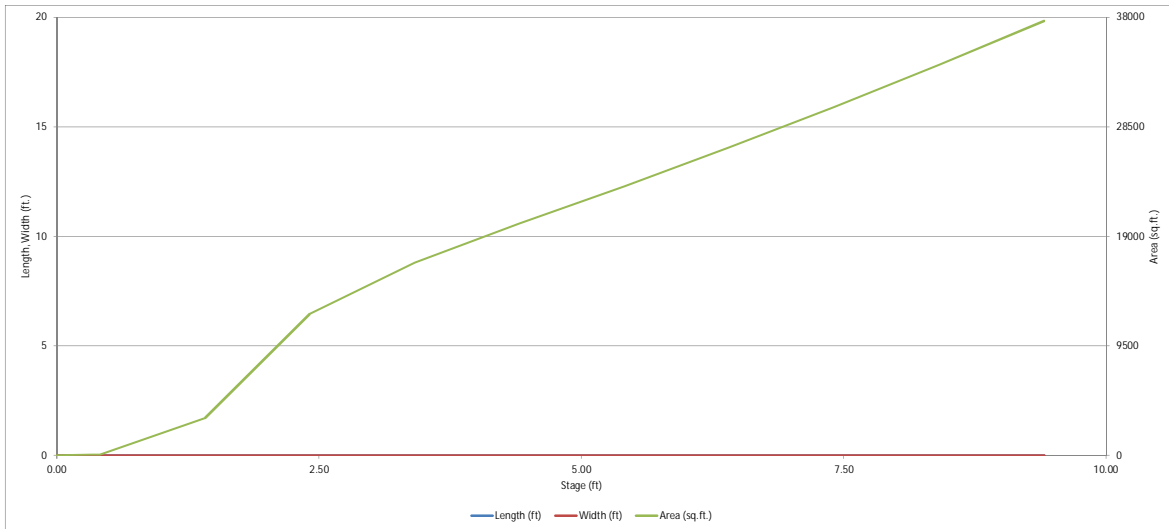

DETENTION BASIN OUTLET STRUCTURE DESIGN

MHFD-Detention, Version 4.04 (February 2021)

Project: **Homestead North Filling No. 2**
 Basin ID: **Pond-Sediment Basin**

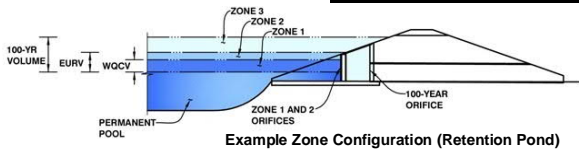

	Estimated Stage (ft)	Estimated Volume (ac-ft)	Outlet Type
Zone 1 (WOCV)	6.76	2.264	Orifice Plate
Zone 2			
Zone 3			
Total (all zones)		2.264	

User Input: Orifice at Underdrain Outlet (typically used to drain WOCV in a Filtration BMP)

Underdrain Orifice Invert Depth = ft (distance below the filtration media surface)
 Underdrain Orifice Diameter = inches

Calculated Parameters for Underdrain
 Underdrain Orifice Area = ft²
 Underdrain Orifice Centroid = feet

User Input: Orifice Plate with one or more orifices or Elliptical Slot Weir (typically used to drain WOCV and/or EURV in a sedimentation BMP)

Invert of Lowest Orifice = ft (relative to basin bottom at Stage = 0 ft)
 Depth at top of Zone using Orifice Plate = ft (relative to basin bottom at Stage = 0 ft)
 Orifice Plate: Orifice Vertical Spacing = inches
 Orifice Plate: Orifice Area per Row = sq. inches (use rectangular openings)

Calculated Parameters for Plate
 WO Orifice Area per Row = ft²
 Elliptical Half-Width = feet
 Elliptical Slot Centroid = feet
 Elliptical Slot Area = ft²

User Input: Stage and Total Area of Each Orifice Row (numbered from lowest to highest)

	Row 1 (required)	Row 2 (optional)	Row 3 (optional)	Row 4 (optional)	Row 5 (optional)	Row 6 (optional)	Row 7 (optional)	Row 8 (optional)
Stage of Orifice Centroid (ft)	0.00	2.25	4.51					
Orifice Area (sq. inches)	3.29	3.29	3.29					

	Row 9 (optional)	Row 10 (optional)	Row 11 (optional)	Row 12 (optional)	Row 13 (optional)	Row 14 (optional)	Row 15 (optional)	Row 16 (optional)
Stage of Orifice Centroid (ft)								
Orifice Area (sq. inches)								

User Input: Vertical Orifice (Circular or Rectangular)

Invert of Vertical Orifice = ft (relative to basin bottom at Stage = 0 ft)
 Depth at top of Zone using Vertical Orifice = ft (relative to basin bottom at Stage = 0 ft)
 Vertical Orifice Diameter = inches

Calculated Parameters for Vertical Orifice
 Vertical Orifice Area = ft²
 Vertical Orifice Centroid = feet

User Input: Overflow Weir (Dropbox with Flat or Sloped Gate and Outlet Pipe OR Rectangular/Trapezoidal Weir (and No Outlet Pipe))

Overflow Weir Front Edge Height, Ho = ft (relative to basin bottom at Stage = 0 ft)
 Overflow Weir Front Edge Length = feet
 Overflow Weir Gate Slope = H:V
 Horiz. Length of Weir Sides = feet
 Overflow Gate Type =
 Debris Clogging % = %

Calculated Parameters for Overflow Weir
 Height of Gate Upper Edge, H₁ = feet
 Overflow Weir Slope Length = feet
 Gate Open Area / 100-yr Orifice Area =
 Overflow Gate Open Area w/o Debris = ft²
 Overflow Gate Open Area w/ Debris = ft²

User Input: Outlet Pipe w/ Flow Restriction Plate (Circular Orifice, Restrictor Plate, or Rectangular Orifice)

Depth to Invert of Outlet Pipe = ft (distance below basin bottom at Stage = 0 ft)
 Circular Orifice Diameter = inches

Calculated Parameters for Outlet Pipe w/ Flow Restriction Plate
 Outlet Orifice Area = ft²
 Outlet Orifice Centroid = feet
 Half-Central Angle of Restrictor Plate on Pipe = radians

User Input: Emergency Spillway (Rectangular or Trapezoidal)

Spillway Invert Stage = ft (relative to basin bottom at Stage = 0 ft)
 Spillway Crest Length = feet
 Spillway End Slopes = H:V
 Freeboard above Max Water Surface = feet

Calculated Parameters for Spillway
 Spillway Design Flow Depth = feet
 Stage at Top of Freeboard = feet
 Basin Area at Top of Freeboard = acres
 Basin Volume at Top of Freeboard = acre-ft

Routed Hydrograph Results

The user can override the default CUHP hydrographs and runoff volumes by entering new values in the Inflow Hydrographs table (Columns W through AF).

	WOCV	EURV	2 Year	5 Year	10 Year	25 Year	50 Year	100 Year	500 Year
Design Storm Return Period									
One-Hour Rainfall Depth (in)	N/A	N/A	1.19	1.50	1.75	2.00	2.25	2.52	4.00
CUHP Runoff Volume (acre-ft)	2.264	2.300	1.253	1.828	2.340	3.053	3.618	4.345	7.870
Inflow Hydrograph Volume (acre-ft)	N/A	N/A	1.253	1.828	2.340	3.053	3.618	4.345	7.870
CUHP Predevelopment Peak Q (cfs)	N/A	N/A	2.9	8.1	12.3	22.1	27.7	35.5	69.6
OPTIONAL Override Predevelopment Peak Q (cfs)	N/A	N/A							
Predevelopment Unit Peak Flow, q (cfs/acre)	N/A	N/A	0.11	0.30	0.45	0.81	1.01	1.29	2.54
Peak Inflow Q (cfs)	N/A	N/A	18.7	28.2	35.2	47.1	56.0	66.8	118.8
Peak Outflow Q (cfs)	0.7	0.7	0.5	0.6	0.7	0.9	21.1	39.1	105.5
Ratio Peak Outflow to Predevelopment Q	N/A	N/A	N/A	0.1	0.1	0.4	0.8	1.1	1.5
Structure Controlling Flow	Plate	Plate	Plate	Plate	Plate	Spillway	Spillway	Spillway	Spillway
Max Velocity through Gate 1 (fps)	N/A	N/A	N/A	N/A	N/A	N/A	N/A	N/A	N/A
Max Velocity through Gate 2 (fps)	N/A	N/A	N/A	N/A	N/A	N/A	N/A	N/A	N/A
Time to Drain 97% of Inflow Volume (hours)	68	68	51	62	70	74	72	71	64
Time to Drain 99% of Inflow Volume (hours)	72	73	53	65	74	79	78	78	75
Maximum Ponding Depth (ft)	6.76	6.82	4.83	5.87	6.70	7.31	7.40	7.50	7.79
Area at Maximum Ponding Depth (acres)	0.64	0.65	0.49	0.57	0.64	0.69	0.69	0.70	0.73
Maximum Volume Stored (acre-ft)	2.266	2.304	1.173	1.726	2.221	2.631	2.693	2.763	2.970

DETENTION BASIN OUTLET STRUCTURE DESIGN

MHFD-Detention, Version 4.04 (February 2021)

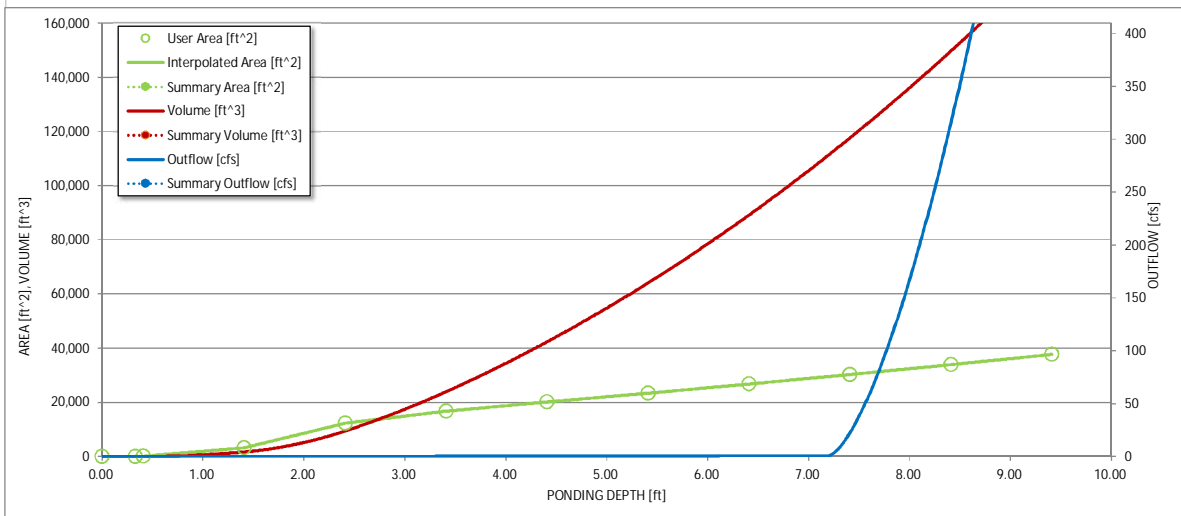
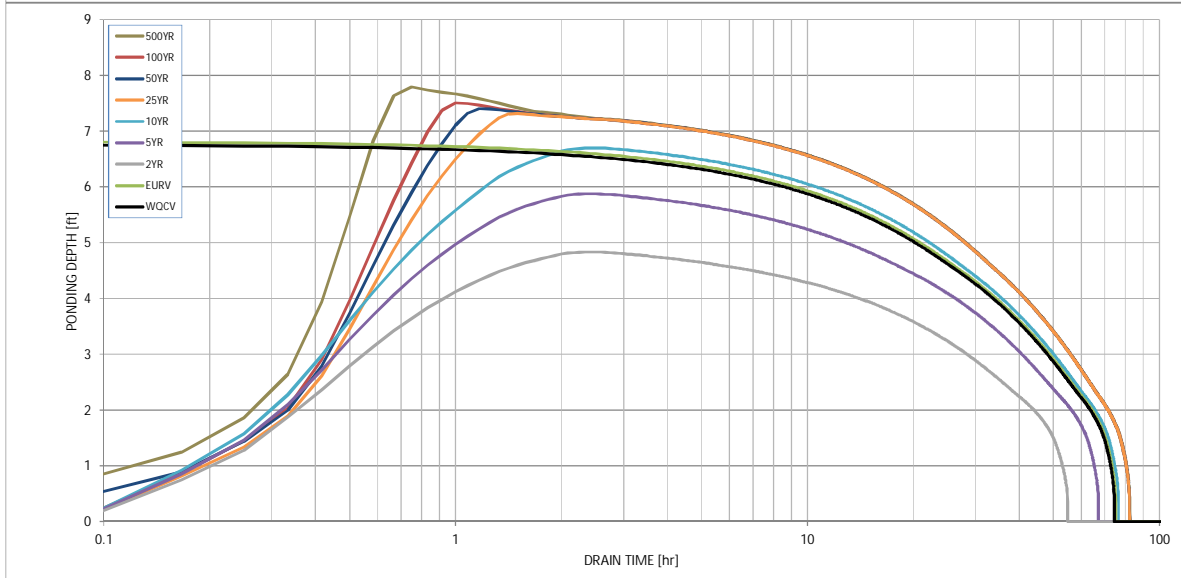
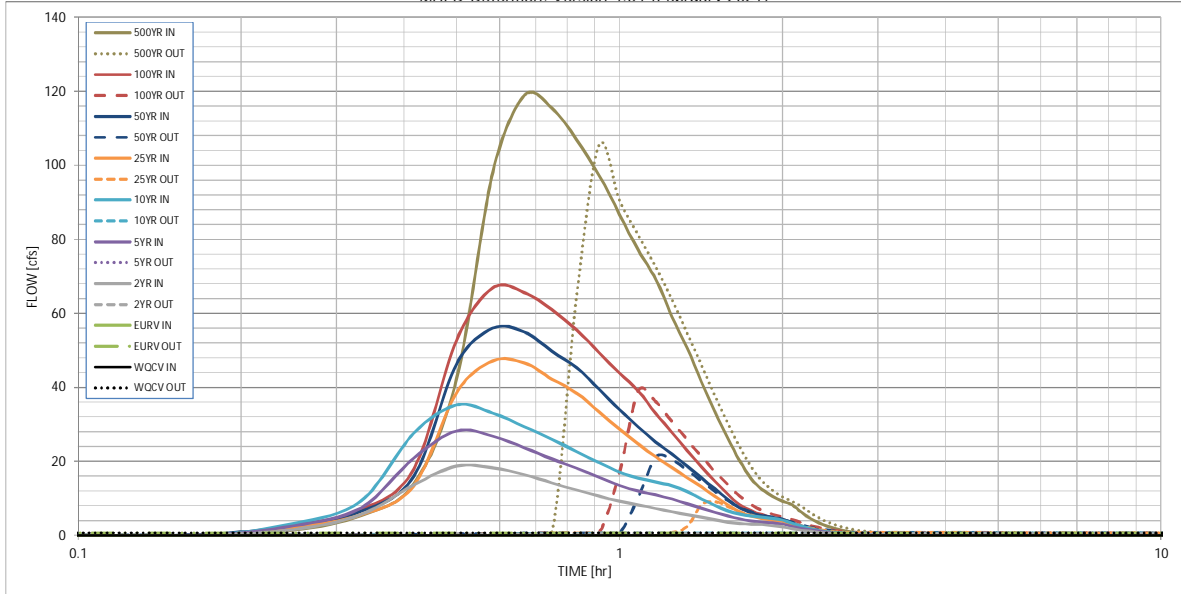

S-A-V-D Chart Axis Override	X-axis	Left Y-Axis	Right Y-Axis
minimum bound			
maximum bound			

DETENTION BASIN OUTLET STRUCTURE DESIGN

Outflow Hydrograph Workbook Filename: _____

Inflow Hydrographs

The user can override the calculated inflow hydrographs from this workbook with inflow hydrographs developed in a separate program.

Time Interval	SOURCE	CUHP	CUHP	CUHP	CUHP	CUHP	CUHP	CUHP	CUHP	CUHP
	TIME	WQCV [cfs]	EURV [cfs]	2 Year [cfs]	5 Year [cfs]	10 Year [cfs]	25 Year [cfs]	50 Year [cfs]	100 Year [cfs]	500 Year [cfs]
5.00 min	0:00:00	0.00	0.00	0.00	0.00	0.00	0.00	0.00	0.00	0.00
	0:05:00	0.00	0.00	0.00	0.00	0.00	0.00	0.00	0.00	0.00
	0:10:00	0.00	0.00	0.00	0.00	0.00	0.00	0.18	0.02	1.35
	0:15:00	0.00	0.00	1.57	2.57	3.18	2.14	2.68	2.61	5.42
	0:20:00	0.00	0.00	5.65	7.49	9.38	5.58	6.51	6.97	13.88
	0:25:00	0.00	0.00	13.63	20.85	27.61	13.42	15.95	17.91	42.25
	0:30:00	0.00	0.00	18.72	28.22	35.24	38.56	46.37	52.77	98.13
	0:35:00	0.00	0.00	18.21	26.78	33.04	47.12	55.96	66.85	118.81
	0:40:00	0.00	0.00	16.45	23.70	29.32	46.60	54.99	65.61	115.45
	0:45:00	0.00	0.00	14.18	20.64	25.96	42.21	49.77	60.98	106.96
	0:50:00	0.00	0.00	12.24	18.16	22.62	38.45	45.33	55.45	97.34
	0:55:00	0.00	0.00	10.62	15.68	19.65	33.39	39.46	49.36	86.70
	1:00:00	0.00	0.00	9.22	13.44	17.07	28.66	33.95	43.80	77.01
	1:05:00	0.00	0.00	8.25	11.96	15.50	24.67	29.31	39.03	69.20
	1:10:00	0.00	0.00	7.27	10.96	14.41	21.20	25.28	32.93	59.19
	1:15:00	0.00	0.00	6.40	9.81	13.40	18.38	21.99	27.79	50.65
	1:20:00	0.00	0.00	5.63	8.55	11.81	15.61	18.64	22.85	41.58
	1:25:00	0.00	0.00	4.88	7.34	9.88	13.06	15.57	18.48	33.48
	1:30:00	0.00	0.00	4.18	6.24	8.12	10.58	12.56	14.64	26.40
	1:35:00	0.00	0.00	3.58	5.30	6.65	8.29	9.78	11.18	20.15
	1:40:00	0.00	0.00	3.18	4.45	5.76	6.35	7.45	8.28	15.29
	1:45:00	0.00	0.00	2.99	3.93	5.24	5.23	6.14	6.63	12.43
	1:50:00	0.00	0.00	2.90	3.58	4.89	4.53	5.31	5.58	10.54
	1:55:00	0.00	0.00	2.59	3.33	4.54	4.09	4.77	4.85	9.23
	2:00:00	0.00	0.00	2.30	3.07	4.11	3.78	4.38	4.32	8.27
	2:05:00	0.00	0.00	1.82	2.42	3.23	2.96	3.42	3.28	6.28
	2:10:00	0.00	0.00	1.40	1.85	2.46	2.23	2.57	2.38	4.57
	2:15:00	0.00	0.00	1.08	1.42	1.86	1.68	1.93	1.74	3.34
	2:20:00	0.00	0.00	0.83	1.08	1.39	1.27	1.45	1.32	2.50
	2:25:00	0.00	0.00	0.63	0.81	1.03	0.95	1.08	0.99	1.86
	2:30:00	0.00	0.00	0.47	0.59	0.76	0.70	0.79	0.74	1.39
	2:35:00	0.00	0.00	0.35	0.43	0.56	0.51	0.58	0.55	1.02
	2:40:00	0.00	0.00	0.25	0.31	0.42	0.38	0.44	0.41	0.76
	2:45:00	0.00	0.00	0.18	0.22	0.29	0.28	0.31	0.29	0.54
	2:50:00	0.00	0.00	0.11	0.15	0.19	0.18	0.21	0.19	0.36
	2:55:00	0.00	0.00	0.06	0.09	0.11	0.11	0.13	0.12	0.21
	3:00:00	0.00	0.00	0.03	0.05	0.05	0.06	0.06	0.06	0.10
	3:05:00	0.00	0.00	0.01	0.02	0.02	0.02	0.02	0.02	0.03
	3:10:00	0.00	0.00	0.00	0.00	0.00	0.00	0.00	0.00	0.00
	3:15:00	0.00	0.00	0.00	0.00	0.00	0.00	0.00	0.00	0.00
	3:20:00	0.00	0.00	0.00	0.00	0.00	0.00	0.00	0.00	0.00
	3:25:00	0.00	0.00	0.00	0.00	0.00	0.00	0.00	0.00	0.00
	3:30:00	0.00	0.00	0.00	0.00	0.00	0.00	0.00	0.00	0.00
	3:35:00	0.00	0.00	0.00	0.00	0.00	0.00	0.00	0.00	0.00
	3:40:00	0.00	0.00	0.00	0.00	0.00	0.00	0.00	0.00	0.00
	3:45:00	0.00	0.00	0.00	0.00	0.00	0.00	0.00	0.00	0.00
	3:50:00	0.00	0.00	0.00	0.00	0.00	0.00	0.00	0.00	0.00
	3:55:00	0.00	0.00	0.00	0.00	0.00	0.00	0.00	0.00	0.00
	4:00:00	0.00	0.00	0.00	0.00	0.00	0.00	0.00	0.00	0.00
	4:05:00	0.00	0.00	0.00	0.00	0.00	0.00	0.00	0.00	0.00
	4:10:00	0.00	0.00	0.00	0.00	0.00	0.00	0.00	0.00	0.00
	4:15:00	0.00	0.00	0.00	0.00	0.00	0.00	0.00	0.00	0.00
	4:20:00	0.00	0.00	0.00	0.00	0.00	0.00	0.00	0.00	0.00
	4:25:00	0.00	0.00	0.00	0.00	0.00	0.00	0.00	0.00	0.00
	4:30:00	0.00	0.00	0.00	0.00	0.00	0.00	0.00	0.00	0.00
	4:35:00	0.00	0.00	0.00	0.00	0.00	0.00	0.00	0.00	0.00
	4:40:00	0.00	0.00	0.00	0.00	0.00	0.00	0.00	0.00	0.00
	4:45:00	0.00	0.00	0.00	0.00	0.00	0.00	0.00	0.00	0.00
	4:50:00	0.00	0.00	0.00	0.00	0.00	0.00	0.00	0.00	0.00
	4:55:00	0.00	0.00	0.00	0.00	0.00	0.00	0.00	0.00	0.00
	5:00:00	0.00	0.00	0.00	0.00	0.00	0.00	0.00	0.00	0.00
	5:05:00	0.00	0.00	0.00	0.00	0.00	0.00	0.00	0.00	0.00
	5:10:00	0.00	0.00	0.00	0.00	0.00	0.00	0.00	0.00	0.00
	5:15:00	0.00	0.00	0.00	0.00	0.00	0.00	0.00	0.00	0.00
	5:20:00	0.00	0.00	0.00	0.00	0.00	0.00	0.00	0.00	0.00
	5:25:00	0.00	0.00	0.00	0.00	0.00	0.00	0.00	0.00	0.00
	5:30:00	0.00	0.00	0.00	0.00	0.00	0.00	0.00	0.00	0.00
	5:35:00	0.00	0.00	0.00	0.00	0.00	0.00	0.00	0.00	0.00
	5:40:00	0.00	0.00	0.00	0.00	0.00	0.00	0.00	0.00	0.00
	5:45:00	0.00	0.00	0.00	0.00	0.00	0.00	0.00	0.00	0.00
	5:50:00	0.00	0.00	0.00	0.00	0.00	0.00	0.00	0.00	0.00
	5:55:00	0.00	0.00	0.00	0.00	0.00	0.00	0.00	0.00	0.00
	6:00:00	0.00	0.00	0.00	0.00	0.00	0.00	0.00	0.00	0.00

APPENDIX D – SWMP REPORT & GEC PLAN CHECKLIST



3275 Akers Drive
 Colorado Springs, CO 80922
 Phone 719-520-6460
 Fax 719-520-6879
 www.elpasoco.com

EL PASO COUNTY STORMWATER MANAGEMENT PLAN CHECKLIST

EPC Project Number:

Revised: October 2021

		Applicant	EPC
1. STORMWATER MANAGEMENT PLAN (in the "Applicant" column specify the page number for each item)			
1	Applicant (owner/designated operator), SWMP Preparer, Qualified Stormwater Manager, and Contractor Information. (On cover/title sheet)		
2	Table of Contents		
3	Site description and location to include: vicinity map with nearest street/crossroads description		
4	Narrative description of construction activities proposed (e.g., may include clearing and grubbing, temporary stabilization, road grading, utility / storm installation, final grading, final stabilization, and removal of temporary control measures)		
5	Phasing plan – may require separate drawings indicating initial, interim, and final site phases for larger projects. Provide "living maps" that can be revised in the field as conditions dictate		
6	Proposed sequence for major activities: Provide a construction schedule of anticipated starting and completion dates for each stage of land-disturbing activity depicting conservation measures anticipated, including the expected date on which the final stabilization will be completed		
7	Estimates of the total site area and area to undergo disturbance; current area of disturbance must be updated on the SWMP as changes occur		
8	Soil erosion potential and impacts on discharge that includes a summary of the data used to determine soil erosion potential		
9	A description of existing vegetation at the site and percent ground cover and method used to determine ground cover		
10	Location and description of all potential pollution sources including but not limited to: disturbed and stored soils; vehicle tracking; management of contaminated soils; loading and unloading operations; outdoor storage of materials; vehicle and equipment maintenance and fueling; significant dust generating process; routine maintenance activities involving fertilizers, pesticides, herbicides, detergents, fuels, solvents, oils, etc.; on-site waste management; concrete truck/equipment washing; dedicated asphalt, concrete batch plants and masonry mixing stations; non-industrial waste such as trash and portable toilets		
11	Material handling to include spill prevention and response plan and procedures		
12	Spill prevention and pollution controls for dedicated batch plants		
13	Other SW pollutant control measures to include waste disposal and off-site soil tracking		
14	Location and description of any anticipated allowable non-stormwater discharge (ground water, springs, irrigation, discharge covered by CDPHE Low Risk Guidance, etc.)		
15	Name(s) of ultimate receiving waters; size, type and location of stormwater outfall or storm sewer system discharge		
16	Description of all stream crossings located within the project area or statement that no streams cross the project area		



3275 Akers Drive
 Colorado Springs, CO 80922
 Phone 719-520-6460
 Fax 719-520-6879
 www.elpasoco.com

EL PASO COUNTY STORMWATER MANAGEMENT PLAN CHECKLIST

EPC Project Number:

Revised: October 2021

		Applicant	EPC
17	SWMP Map to include:		
17a	construction site boundaries		
17b	flow arrows to depict stormwater flow directions		
17c	all areas of disturbance		
17d	areas of cut and fill		
17e	areas used for storage of building materials, soils (stockpiles) or wastes		
17f	location of any dedicated asphalt / concrete batch plants		
17g	location of all structural control measures		
17h	location of all non-structural control measures		
17i	springs, streams, wetlands and other surface waters, including areas that require maintenance of pre-existing vegetation within 50 feet of a receiving water		
18	Narrative description of all structural control measures to be used. Modifications to EPC standard control measures must meet or exceed County-approved details		
19	Description of all non-structural control measures to be used including seeding, mulching, protection of existing vegetation, site watering, sod placement, etc.		
20	Technical drawing details for all control measure installation and maintenance; custom or other jurisdiction's details used must meet or exceed EPC standards		
21	Procedure describing how the SWMP is to be revised		
22	Description of Final Stabilization and Long-term Stormwater Quality (describe nonstructural and structural measures to control SW pollutants after construction operations have been completed, including detention, water quality control measure etc.)		
23	Specification that final vegetative cover density is to be 70% of pre-disturbed levels		
24	Outline of permit holder inspection procedures to install, maintain, and effectively operate control measures to manage erosion and sediment		
25	Record keeping procedures identified to include signature on inspection logs and location of SWMP records on-site		
26	If this project relies on control measures owned or operated by another entity, a documented agreement must be included in the SWMP that identifies location, installation and design specifications, and maintenance requirements and responsibility of the control measure(s)		
Please note: all items above must be addressed. If not applicable, explain why, simply identifying "not applicable" will not satisfy CDPHE requirement of explanation.			
2. ADDITIONAL REPORTS/PERMITS/DOCUMENTS			
a	Grading and Erosion Control Plan (signed)		
b	Erosion and Stormwater Quality Control Permit (ESQCP) (signed)		



3275 Akers Drive
 Colorado Springs, CO 80922
 Phone 719-520-6460
 Fax 719-520-6879
 www.elpasoco.com

EL PASO COUNTY STORMWATER MANAGEMENT PLAN CHECKLIST

EPC Project Number:

Revised: October 2021

		Applicant	EPC
3. APPLICANT COMMENTS			
a			
b			
c			
4. CHECKLIST REVIEW CERTIFICATIONS			
a	<p>Applicant: The Stormwater Management Plan was prepared under my direction and supervision and is correct to the best of my knowledge and belief. Said Plan has been prepared according to the criteria established by the County and State for Stormwater Management Plans.</p> <p style="text-align: center;"><i>RYAN BURNS</i></p> <hr style="width: 50%; margin-left: 0;"/> <p>Engineer of Record and/or Qualified Stormwater Manager Signature Date</p>		
b	<p>Review Engineer: The Stormwater Management Plan was reviewed and found to meet the checklist requirements except where otherwise noted or allowed by an approved deviation request.</p> <hr style="width: 50%; margin-left: 0;"/> <p>Review Engineer Date</p>		



3275 Akers Drive
 Colorado Springs, CO 80922
 Phone 719-520-6460
 Fax 719-520-6879
 www.elpasoco.com

EL PASO COUNTY GRADING AND EROSION CONTROL PLAN CHECKLIST

EPC Project Number:

Revised: October 2021

		Applicant	EPC
1. GRADING AND EROSION CONTROL PLAN (complete form using Y, N, N/A in the "Applicant" column)			
a	Vicinity map		
b	Adjacent city/town/jurisdictional boundaries, subdivision names, and property parcel numbers labeled		
c	North arrow and acceptable scale (1"=20' to 1"=100')		
d	Legend for all symbols used in the plan		
e	Existing and proposed property lines. Proposed subdivision boundary for subdivision projects		
f	All existing structures		
g	All existing utilities		
h	Construction site boundaries		
i	Existing vegetation (notes are acceptable in cases where there is no notable vegetation, only grasses/weeds, or site has already been stripped)		
j	FEMA 100-yr floodplain		
k	Existing and proposed water courses including springs, streams, wetlands, detention ponds, stormwater quality structures, roadside ditches, irrigation ditches and other water surfaces. Show maintenance of pre-existing vegetation within 50 feet of a receiving water		
l	Existing and proposed contours 2 feet or less (except for hillside)		
m	Limits of disturbance delineating all anticipated areas of soil disturbance		
n	Identify and protect areas outside of the construction site boundary with existing fencing, construction fencing or other methods as appropriate		
o	Off-site grading clearly shown and called out		
p	Areas of cut and fill identified		
q	Conclusions from soils/geotechnical report and geologic hazards report incorporated in grading design (slopes, embankments, materials, mitigation, etc.)		
r	Proposed slopes steeper than 3:1 with top and toe of slope delineated. Erosion control blanketing or other protective covering required		
s	Stormwater flow direction arrows		
t	Location of any dedicated asphalt / concrete batch plants		
u	Areas used for staging, storage of building materials, soils (stockpiles) or wastes. The use of construction office trailers requires PCD permitting		
v	All proposed temporary construction control measures, structural and non-structural. Temporary construction control measures shall be identified by phase of implementation to include "initial," "interim," and "final" or shown on separate phased maps identifying each phase		
w	Vehicle tracking provided at all construction entrances/exits. Construction fencing, barricades, and/or signage provided at access points not to be used for construction		
x	Temporary sediment ponds provided for disturbed drainage areas greater than 1 acre		



3275 Akers Drive
 Colorado Springs, CO 80922
 Phone 719-520-6460
 Fax 719-520-6879
 www.elpasoco.com

EL PASO COUNTY GRADING AND EROSION CONTROL PLAN CHECKLIST

EPC Project Number:

Revised: October 2021

		Applicant	EPC
y	Dewatering operations to include locations of diversion, pump and discharge(s) as anticipated at time of design		
z	All proposed temporary construction control measure details. Custom or other jurisdiction's details used must meet or exceed EPC standards		
aa	Any off-site stormwater control measure proposed for use by the project and not under the direct control or ownership of the Owner or Operator		
bb	Existing and proposed permanent storm water management facilities, including areas proposed for stormwater infiltration or subsurface detention		
cc	Existing and proposed easements (permanent and construction) including required off-site easements		
dd	Retaining walls shall not to be located in County ROW unless approved via license agreement. A building permit from Regional Building Department is required for walls greater than or equal to 4 feet in height, series of walls, or walls supporting a surcharge and must be design by P.E.		
ee	Plan certified by a Colorado Registered P.E., with EPC standard signature blocks for Engineer, Owner and EPC		
ff	<p>Engineer's Statement (for standalone GEC Plan): This Grading and Erosion Control Plan was prepared under my direction and supervision and is correct to the best of my knowledge and belief. Said Plan has been prepared according to the criteria established by the County for Grading and Erosion Control Plans. I accept responsibility for any liability caused by any negligent acts, errors or omissions on my part in preparing this plan.</p> <p>_____ Date</p> <p>Engineer of Record Signature</p>		
gg	<p>Engineer's Statement (for GEC Plan within Construction Drawing set): These detailed plans and specifications were prepared under my direction and supervision. Said plans and specifications have been prepared according to the criteria established by the County for detailed roadway, drainage, grading and erosion control plans and specifications, and said plans and specifications are in conformity with applicable master drainage plans and master transportation plans. Said plans and specifications meet the purposes for which the particular roadway and drainage facilities are designed and are correct to the best of my knowledge and belief. I accept responsibility for any liability caused by any negligent acts, errors or omissions on my part in preparation of these detailed plans and specifications.</p> <p>_____ Date</p> <p>Engineer of Record Signature</p>		
hh	<p>Owner's Statement (for standalone GEC Plan): I, the owner/developer have read and will comply with the requirements of the Grading and Erosion Control Plan.</p> <p>_____ Date</p> <p>Owner Signature</p>		
ii	<p>Owner's Statement (for GEC Plan within Construction Drawing set): I, the owner/developer have read and will comply with the requirements of the grading and erosion control plan and all of the requirements specified in these detailed plans and specifications.</p> <p>_____ Date</p> <p>Owner Signature</p>		



3275 Akers Drive
 Colorado Springs, CO 80922
 Phone 719-520-6460
 Fax 719-520-6879
 www.elpasoco.com

EL PASO COUNTY GRADING AND EROSION CONTROL PLAN CHECKLIST

EPC Project Number:

Revised: October 2021

		Applicant	EPC
jj	<p>El Paso County: County plan review is provided only for general conformance with County Design Criteria. The County is not responsible for the accuracy and adequacy of the design, dimensions, and/ or elevations which shall be confirmed at the job site. The County through the approval of this document assumes no responsibility for completeness and/ or accuracy of this document.</p> <p>Filed in accordance with the requirements of the El Paso County Land Development Code, Drainage Criteria Manual Volumes 1 and 2, and Engineering Criteria Manual, as amended.</p> <p>In accordance with ECM Section 1.12, these construction documents will be valid for construction for a period of 2 years from the date signed by the El Paso County Engineer. If construction has not started within those 2 years, the plans will need to be resubmitted for approval, including payment of review fees at the Planning and Community Development Director's discretion.</p> <p>_____ Date Jennifer Irvine, P.E. County Engineer/ECM Administrator</p>		
2. ADDITIONAL REPORTS/PERMITS/DOCUMENTS			
a	Soils report / geotechnical investigation as appropriate for grading/utilities/drainage/road construction.		
b	Use Agreement/easement between the Owner or Operator and other third party for use of all off-site grading or stormwater control measures, used by the owner or operator but not under their direct control or ownership.		
c	Floodplain Development Permit		
d	USACE 404/wetlands permit/mitigation plan		
e	FEMA CLOMR		
f	State Engineer's permit/Notice Of Intent to Construct		
g	Stormwater Management Plan (SWMP)		
h	Financial Assurance Estimate (FAE) (signed)		
i	Erosion and Stormwater Quality Control Permit (ESQCP) (signed)		
j	Pre-Development Site Grading Acknowledgement & Right of Access Form (signed)		
k	Conditions of Approval met?		



3275 Akers Drive
 Colorado Springs, CO 80922
 Phone 719-520-6460
 Fax 719-520-6879
 www.elpasoco.com

EL PASO COUNTY GRADING AND EROSION CONTROL PLAN CHECKLIST

EPC Project Number:

Revised: October 2021

		Applicant	EPC
3. STANDARD NOTES FOR EL PASO COUNTY GRADING AND EROSION CONTROL PLANS			
1	Stormwater discharges from construction sites shall not cause or threaten to cause pollution, contamination, or degradation of State Waters. All work and earth disturbance shall be done in a manner that minimizes pollution of any on-site or off-site waters, including wetlands.		
2	Notwithstanding anything depicted in these plans in words or graphic representation, all design and construction related to roads, storm drainage and erosion control shall conform to the standards and requirements of the most recent version of the relevant adopted El Paso County standards, including the Land Development Code, the Engineering Criteria Manual, the Drainage Criteria Manual, and the Drainage Criteria Manual Volume 2. Any deviations from regulations and standards must be requested, and approved, in writing.		
3	A separate Stormwater Management Plan (SMWP) for this project shall be completed and an Erosion and Stormwater Quality Control Permit (ESQCP) issued prior to commencing construction. Management of the SWMP during construction is the responsibility of the designated Qualified Stormwater Manager or Certified Erosion Control Inspector. The SWMP shall be located on-site at all times during construction and shall be kept up to date with work progress and changes in the field.		
4	Once the ESQCP is approved and a "Notice to Proceed" has been issued, the contractor may install the initial stage erosion and sediment control measures as indicated on the approved GEC. A Preconstruction Meeting between the contractor, engineer, and El Paso County will be held prior to any construction. It is the responsibility of the applicant to coordinate the meeting time and place with County staff.		
5	Control measures must be installed prior to commencement of activities that could contribute pollutants to stormwater. Control measures for all slopes, channels, ditches, and disturbed land areas shall be installed immediately upon completion of the disturbance.		
6	All temporary sediment and erosion control measures shall be maintained and remain in effective operating condition until permanent soil erosion control measures are implemented and final stabilization is established. All persons engaged in land disturbance activities shall assess the adequacy of control measures at the site and identify if changes to those control measures are needed to ensure the continued effective performance of the control measures. All changes to temporary sediment and erosion control measures must be incorporated into the Stormwater Management Plan.		
7	Temporary stabilization shall be implemented on disturbed areas and stockpiles where ground disturbing construction activity has permanently ceased or temporarily ceased for longer than 14 days.		
8	Final stabilization must be implemented at all applicable construction sites. Final stabilization is achieved when all ground disturbing activities are complete and all disturbed areas either have a uniform vegetative cover with individual plant density of 70 percent of pre-disturbance levels established or equivalent permanent alternative stabilization method is implemented. All temporary sediment and erosion control measures shall be removed upon final stabilization and before permit closure.		
9	All permanent stormwater management facilities shall be installed as designed in the approved plans. Any proposed changes that effect the design or function of permanent stormwater management structures must be approved by the ECM Administrator prior to implementation.		



3275 Akers Drive
 Colorado Springs, CO 80922
 Phone 719-520-6460
 Fax 719-520-6879
 www.elpasoco.com

EL PASO COUNTY GRADING AND EROSION CONTROL PLAN CHECKLIST

EPC Project Number:

Revised: October 2021

		Applicant	EPC
10	Earth disturbances shall be conducted in such a manner so as to effectively minimize accelerated soil erosion and resulting sedimentation. All disturbances shall be designed, constructed, and completed so that the exposed area of any disturbed land shall be limited to the shortest practical period of time. Pre-existing vegetation shall be protected and maintained within 50 horizontal feet of a waters of the state unless shown to be infeasible and specifically requested and approved.		
11	Compaction of soil must be prevented in areas designated for infiltration control measures or where final stabilization will be achieved by vegetative cover. Areas designated for infiltration control measures shall also be protected from sedimentation during construction until final stabilization is achieved. If compaction prevention is not feasible due to site constraints, all areas designated for infiltration and vegetation control measures must be loosened prior to installation of the control measure(s).		
12	Any temporary or permanent facility designed and constructed for the conveyance of stormwater around, through, or from the earth disturbance area shall be a stabilized conveyance designed to minimize erosion and the discharge of sediment off-site.		
13	Concrete wash water shall be contained and disposed of in accordance with the SWMP. No wash water shall be discharged to or allowed to enter State Waters, including any surface or subsurface storm drainage system or facilities. Concrete washouts shall not be located in an area where shallow groundwater may be present, or within 50 feet of a surface water body, creek or stream.		
14	During dewatering operations, uncontaminated groundwater may be discharged on-site, but shall not leave the site in the form of surface runoff unless an approved State dewatering permit is in place.		
15	Erosion control blanketing or other protective covering shall be used on slopes steeper than 3:1.		
16	Contractor shall be responsible for the removal of all wastes from the construction site for disposal in accordance with local and State regulatory requirements. No construction debris, tree slash, building material wastes or unused building materials shall be buried, dumped, or discharged at the site.		
17	Waste materials shall not be temporarily placed or stored in the street, alley, or other public way, unless in accordance with an approved Traffic Control Plan. Control measures may be required by El Paso County Engineering if deemed necessary, based on specific conditions and circumstances.		
18	Tracking of soils and construction debris off-site shall be minimized. Materials tracked off-site shall be cleaned up and properly disposed of immediately.		
19	The owner/developer shall be responsible for the removal of all construction debris, dirt, trash, rock, sediment, soil, and sand that may accumulate in roads, storm drains and other drainage conveyance systems and stormwater appurtenances as a result of site development.		
20	The quantity of materials stored on the project site shall be limited, as much as practical, to that quantity required to perform the work in an orderly sequence. All materials stored on-site shall be stored in a neat, orderly manner, in their original containers, with original manufacturer's labels.		
21	No chemical(s) having the potential to be released in stormwater are to be stored or used on-site unless permission for the use of such chemical(s) is granted in writing by the ECM Administrator. In granting approval for the use of such chemical(s), special conditions and monitoring may be required.		
22	Bulk storage of allowed petroleum products or other allowed liquid chemicals in excess of 55 gallons shall require adequate secondary containment protection to contain all spills on-site and to prevent any spilled materials from entering State Waters, any surface or subsurface storm drainage system or other facilities.		



3275 Akers Drive
 Colorado Springs, CO 80922
 Phone 719-520-6460
 Fax 719-520-6879
 www.elpasoco.com

EL PASO COUNTY GRADING AND EROSION CONTROL PLAN CHECKLIST

EPC Project Number:

Revised: October 2021

		Applicant	EPC
23	No person shall cause the impediment of stormwater flow in the curb and gutter or ditch except with approved sediment control measures.		
24	Owner/developer and their agents shall comply with the "Colorado Water Quality Control Act" (Title 25, Article 8, CRS), and the "Clean Water Act" (33 USC 1344), in addition to the requirements of the Land Development Code, DCM Volume II and the ECM Appendix I. All appropriate permits must be obtained by the contractor prior to construction (1041, NPDES, Floodplain, 404, fugitive dust, etc.). In the event of conflicts between these requirements and other laws, rules, or regulations of other Federal, State, local, or County agencies, the most restrictive laws, rules, or regulations shall apply.		
25	All construction traffic must enter/exit the site only at approved construction access points.		
26	Prior to construction the permittee shall verify the location of existing utilities.		
27	A water source shall be available on-site during earthwork operations and shall be utilized as required to minimize dust from earthwork equipment and wind.		
28	The soils report for this site has been prepared by [Company Name, Date of Report] and shall be considered a part of these plans.		
29	At least ten (10) days prior to the anticipated start of construction, for projects that will disturb one (1) acre or more, the owner or operator of construction activity shall submit a permit application for stormwater discharge to the Colorado Department of Public Health and Environment, Water Quality Division. The application contains certification of completion of a stormwater management plan (SWMP), of which this Grading and Erosion Control Plan may be a part. For information or application materials contact: Colorado Department of Public Health and Environment Water Quality Control Division WQCD – Permits 4300 Cherry Creek Drive South Denver, CO 80246-1530 Attn: Permits Unit		
4. APPLICANT COMMENTS			
a			
b			
c			



3275 Akers Drive
 Colorado Springs, CO 80922
 Phone 719-520-6460
 Fax 719-520-6879
 www.elpasoco.com

EL PASO COUNTY GRADING AND EROSION CONTROL PLAN CHECKLIST

EPC Project Number: SF 2218

Revised: October 2021

Applicant	EPC
-----------	-----

5. CHECKLIST REVIEW CERTIFICATIONS

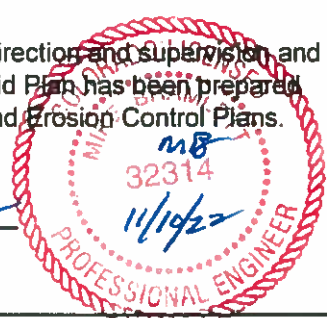
a	<p>Engineer of Record: The Grading and Erosion Control Plan was prepared under my direction and supervision and is complete and correct to the best of my knowledge and belief. Said Plan has been prepared according to the criteria established by the County for Grading and Erosion Control Plans.</p> <p style="text-align: center;">  11/10/22 </p> <p style="text-align: center;"> </p> <p style="text-align: center;"> Engineer of Record Signature Date </p> <div style="text-align: right; margin-top: 20px;">  </div>		
b	<p>Review Engineer: The Grading and Erosion Control Plan was reviewed and found to meet the checklist requirements except where otherwise noted or allowed by an approved deviation request.</p> <p style="text-align: center;"> </p> <p style="text-align: center;"> Review Engineer Date </p>		

APPENDIX E – INSPECTION REPORT TEMplete

CONSTRUCTION STORMWATER SITE INSPECTION REPORT

Facility Name		Permittee					
Date of Inspection		Weather Conditions					
Permit Certification #		Disturbed Acreage					
Phase of Construction		Inspector Title					
Inspector Name							
Is the above inspector a qualified stormwater manager? (permittee is responsible for ensuring that the inspector is a qualified stormwater manager)			<table border="1" style="width: 100%; border-collapse: collapse;"> <tr> <td style="width: 50%; text-align: center;">YES</td> <td style="width: 50%; text-align: center;">NO</td> </tr> <tr> <td style="text-align: center;"><input type="checkbox"/></td> <td style="text-align: center;"><input type="checkbox"/></td> </tr> </table>	YES	NO	<input type="checkbox"/>	<input type="checkbox"/>
YES	NO						
<input type="checkbox"/>	<input type="checkbox"/>						

INSPECTION FREQUENCY					
Check the box that describes the minimum inspection frequency utilized when conducting each inspection					
At least one inspection every 7 calendar days	<input type="checkbox"/>				
At least one inspection every 14 calendar days, with post-storm event inspections conducted within 24 hours after the end of any precipitation or snowmelt event that causes surface erosions	<input type="checkbox"/>				
<ul style="list-style-type: none"> • This is this a post-storm event inspection. Event Date: _____ 	<input type="checkbox"/>				
Reduced inspection frequency - Include site conditions that warrant reduced inspection frequency	<input type="checkbox"/>				
<ul style="list-style-type: none"> • Post-storm inspections at temporarily idle sites 	<input type="checkbox"/>				
<ul style="list-style-type: none"> • Inspections at completed sites/area 	<input type="checkbox"/>				
<ul style="list-style-type: none"> • Winter conditions exclusion 	<input type="checkbox"/>				
Have there been any deviations from the minimum inspection schedule? If yes, describe below.	<table border="1" style="width: 100%; border-collapse: collapse;"> <tr> <td style="width: 50%; text-align: center;">YES</td> <td style="width: 50%; text-align: center;">NO</td> </tr> <tr> <td style="text-align: center;"><input type="checkbox"/></td> <td style="text-align: center;"><input type="checkbox"/></td> </tr> </table>	YES	NO	<input type="checkbox"/>	<input type="checkbox"/>
YES	NO				
<input type="checkbox"/>	<input type="checkbox"/>				

INSPECTION REQUIREMENTS*
i. Visually verify all implemented control measures are in effective operational condition and are working as designed in the specifications
ii. Determine if there are new potential sources of pollutants
iii. Assess the adequacy of control measures at the site to identify areas requiring new or modified control measures to minimize pollutant discharges
iv. Identify all areas of non-compliance with the permit requirements, and if necessary, implement corrective action
*Use the attached Control Measures Requiring Routine Maintenance and Inadequate Control Measures Requiring Corrective Action forms to document results of this assessment that trigger either maintenance or corrective actions

AREAS TO BE INSPECTED			
Is there evidence of, or the potential for, pollutants leaving the construction site boundaries, entering the stormwater drainage system or discharging to state waters at the following locations?			
	NO	YES	If "YES" describe discharge or potential for discharge below. Document related maintenance, inadequate control measures and corrective actions Inadequate Control Measures Requiring Corrective Action form
Construction site perimeter	<input type="checkbox"/>	<input type="checkbox"/>	
All disturbed areas	<input type="checkbox"/>	<input type="checkbox"/>	
Designated haul routes	<input type="checkbox"/>	<input type="checkbox"/>	
Material and waste storage areas exposed to precipitation	<input type="checkbox"/>	<input type="checkbox"/>	
Locations where stormwater has the potential to discharge offsite	<input type="checkbox"/>	<input type="checkbox"/>	
Locations where vehicles exit the site	<input type="checkbox"/>	<input type="checkbox"/>	
Other: _____	<input type="checkbox"/>	<input type="checkbox"/>	

REPORTING REQUIREMENTS

The permittee shall report the following circumstances orally within twenty-four (24) hours from the time the permittee becomes aware of the circumstances, and shall mail to the division a written report containing the information requested within five (5) working days after becoming aware of the following circumstances. The division may waive the written report required if the oral report has been received within 24 hours.

All Noncompliance Requiring 24-Hour Notification per Part II.L.6 of the Permit		
a. Endangerment to Health or the Environment Circumstances leading to any noncompliance which may endanger health or the environment regardless of the cause of the incident (See Part II.L.6.a of the Permit) <i>This category would primarily result from the discharge of pollutants in violation of the permit</i>		
b. Numeric Effluent Limit Violations <ul style="list-style-type: none"> o Circumstances leading to any unanticipated bypass which exceeds any effluent limitations (See Part II.L.6.b of the Permit) o Circumstances leading to any upset which causes an exceedance of any effluent limitation (See Part II.L.6.c of the Permit) o Daily maximum violations (See Part II.L.6.d of the Permit) <i>Numeric effluent limits are very uncommon in certifications under the COR400000 general permit. This category of noncompliance only applies if numeric effluent limits are included in a permit certification.</i>		

Has there been an incident of noncompliance requiring 24-hour notification?	NO	YES	
	<input type="checkbox"/>	<input type="checkbox"/>	If "YES" document below

Date and Time of Incident	Location	Description of Noncompliance	Description of Corrective Action	Date and Time of 24 Hour Oral Notification	Date of 5 Day Written Notification *

*Attach copy of 5 day written notification to report. Indicate if written notification was waived, including the name of the division personnel who granted waiver.

After adequate corrective action(s) and maintenance have been taken, or where a report does not identify any incidents requiring corrective action or maintenance, the individual(s) designated as the Qualified Stormwater Manager, shall sign and certify the below statement:

"I verify that, to the best of my knowledge and belief, all corrective action and maintenance items identified during the inspection are complete, and the site is currently in compliance with the permit."

Name of Qualified Stormwater Manager

Title of Qualified Stormwater Manager

Signature of Qualified Stormwater Manager

Date

Notes/Comments