



LSC TRANSPORTATION CONSULTANTS, INC.  
2504 East Pikes Peak Avenue, Suite 304  
Colorado Springs, CO 80909  
(719) 633-2868  
FAX (719) 633-5430  
E-mail: [lsc@lsctrans.com](mailto:lsc@lsctrans.com)  
Website: <http://www.lsctrans.com>

Grandwood Ranch  
Traffic Impact Study  
PDC File No. P191 & SP195  
(LSC #185020)  
April 17, 2020

**Traffic Engineer's Statement**

This traffic report and supporting information were prepared under my responsible charge and they comport with the standard of care. So far as is consistent with the standard of care, said report was prepared in general conformance with the criteria established by the County for traffic reports.

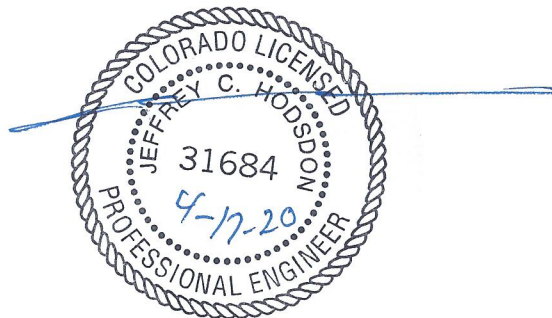

**Developer's Statement**

I, the Developer, have read and will comply with all commitments made on my behalf within this report.

\_\_\_\_\_

\_\_\_\_\_

Date



LSC TRANSPORTATION CONSULTANTS, INC.  
545 East Pikes Peak Avenue, Suite 210  
Colorado Springs, CO 80903  
(719) 633-2868  
FAX (719) 633-5430  
E-mail: [lsc@lsctrans.com](mailto:lsc@lsctrans.com)  
Website: <http://www.lsctrans.com>

April 17, 2020

Bill Herebic  
Grandwood Enterprises  
270 Lodgepole Way  
Monument, CO 80132

RE: Grandwood Ranch  
El Paso County, CO  
Traffic Impact Study  
LSC #185020  
PCD File No. P191 & SP195

Dear Mr. Herebic,

LSC Transportation Consultants, Inc. has prepared this traffic impact study for the proposed Grandwood Ranch residential development with 48 single-family units in El Paso County, Colorado. Located at El Paso County parcel ID 6119000003, the 146.84-acre parcel on the north side of Higby Road between Fairplay Drive and Colonial Park Drive is currently vacant land.

El Paso County is requiring this development to extend Furrow Road south from Lamplighter Court through the site to Higby Road. The plans show the future intersection of Furrow/Higby located approximately 1,180 feet east of the center of Higby Road/Fairplay Drive.

Three access points are proposed for the property. These access points would become public street intersections. Access to the east portion of the site is proposed to Higby Road approximately 980 feet west of the center of Higby Road/Colonial Park Drive. Access to the west portion of the site would be to Furrow Road (extended) at 707 feet north of Higby Road and 879 feet south of the intersection of Furrow Road/Minglewood Trail/Lamplight Drive. This report has been prepared for resubmittal to El Paso County. The previous version of this report was dated February 12, 2019.

## REPORT CONTENTS

The preparation of this report included the following:

- An inventory of existing roadway and traffic conditions on Higby Road adjacent to the site, including surface conditions, functional classification, widths, pavement markings,

traffic control signs, posted speed limits, intersection and access spacing, roadway and intersection alignments, roadway grades and auxiliary turn lanes.

- Weekday peak-hour turning movement traffic counts at the intersections of Higby Road/Fairplay Drive and Highway 105/Furrow Road.
- Estimated average weekday traffic (AWT) volumes for Higby Road adjacent to the proposed residential development site.
- Projections of short-term (with the Furrow connection to Higby Road) and 20-year background traffic volumes on Higby Road adjacent to the site and Furrow Road through the site.
- The proposed site land use and access plan.
- Evaluation of intersection sight distance.
- Estimates of average weekday and weekday peak-hour trip generation for the proposed Grandwood Ranch residential development and the estimated directional distribution of site-generated vehicle-trips on the streets and intersections adjacent to the site.
- Projected site-generated and resulting total peak-hour intersection traffic volumes at the site access points on Higby Road and the future planned intersection of Furrow Road with the west access intersection.
- Projected total daily and peak-hour traffic volumes on Higby Road and Furrow Road adjacent to the site.
- Intersection level of service analysis at the following intersections:
  - Highway 105/Furrow Road
  - Furrow Road/Higby Road
  - Higby Road/West Copper Valley Court/East Copper Valley Court
  - Higby Road/Grandwood Court
  - Higby Road/Fairplay Drive
- Evaluation of existing, short-term, and long-term projected intersection volumes to determine the short-term requirements for auxiliary right-/left-turn lanes on Higby Road, based on the criteria in El Paso County's *Engineering Criteria Manual* (ECM). Also included are the potential long-term lane requirements.
- Findings and recommendations.

#### **LIST OF OTHER TRAFFIC REPORTS USED IN THE PREPARATION OF THIS REPORT**

Homeplace Ranch (non-LSC), Sanctuary Pointe, The Highway 105 Corridor Study (EPC) and the projected MTCP traffic volumes were used in preparation of this report.

#### **LAND USE AND ACCESS**

Figure 1 shows the site location relative to the adjacent and nearby streets. The proposed Grandwood Ranch residential development is proposed to contain approximately 48 single-family dwelling units. Located at El Paso County parcel ID 6119000003, the 146.84-acre site on Higby Road is currently vacant between Fairplay Drive and Colonial Park Drive.

Figure 2 contains the proposed site plan showing the individual residential units, site circulation, and the access points. Two access points are proposed for the property. The Furrow/Higby Road intersection is proposed to be located approximately 1,180 feet east of the center of Higby Road/Fairplay Drive. Higby Road/Grandwood Court intersection (providing access to lots on the east portion of the site) is proposed approximately 980 feet west of the center of Higby Road/Colonial Park Drive. Both access points are proposed as full-movement, stop sign-controlled intersections. Access to the west area of the site (Furrow Road/Copper Valley Court) would be about 700 feet north of Higby Road.

## **ROAD AND TRAFFIC CONDITIONS**

Figure 1 shows the streets adjacent to and in the vicinity of the site. Adjacent streets serving the site are identified below followed by a brief description of each:

**Higby Road** is shown as a two-lane Collector from Jackson Creek Parkway to Furrow Road and as a Minor Arterial from Furrow Road to Roller Coaster Road on the El Paso County *Year 2040 Roadway Plan*. Adjacent to both proposed site access points, Higby Road has a posted speed limit of 35 miles per hour (mph). Higby Road is an unimproved, 24-foot-wide roadway.

**Furrow Road** is a two-lane Rural Major Collector that terminates approximately 1,500 feet north of Higby Road. El Paso County's *Major Transportation Corridors Plan* (MTCP) shows a planned extension that will connect Furrow Road to Higby Road by 2040. Currently, the posted speed limit on Furrow Road is 25 mph. The intersection of Highway 105/Furrow Road has the following auxiliary turn lanes: eastbound left- and westbound left-, and northbound right-turn.

El Paso County is requiring this development to extend Furrow Road south from Lamplight Court through the site to Higby Road. Furrow Road extended south to Higby Road would form a full-movement, stop sign-controlled T-intersection in the short term.

## **Existing Traffic Volumes**

Vehicular turning movement counts were conducted at the intersection of Furrow Road/Highway 105 on Tuesday, August 27, 2019 from 6:30 to 8:30 a.m. and from 4:00 to 6:00 p.m. Additionally, vehicular turning movement counts were available in the Homeplace Ranch traffic report for the intersection of Higby Road/Fairplay Drive on Wednesday, May 16, 2018 from 7:00 to 9:00 a.m. and 4:00 to 6:00 p.m.

Figure 3 shows these turning movement volumes, as well as the average weekday traffic volumes (estimated based on factored peak-hour count data) on the study area streets. Raw count data is attached.

Bill Herebic  
Grandwood Ranch

Update the narrative to quantify the percentage and volume of background traffic assumed to shift when Furrow Road is extended to Higby. In conjunction with the narrative, provide an exhibit similar to the directional distribution will be helpful to show your assumed shift with the extension to provide a clear picture of the assumed change in traffic pattern.

April 17, 2019  
Traffic Impact Study

**SHORT-TERM B.**

Figure 4 shows traffic volumes estimated by LSC including the trip

**Unresolved. Staff is expecting an actual value to be stated in the narrative per the original comment above (underlined).**

volumes. These have been to Higby Road (but not

These volumes have been estimated using the existing traffic count data at Highway 105/Furrow intersection. The volumes estimate the shift in traffic volumes to/from the south by Hope Montessori and existing resident traffic currently using the Highway 105/Furrow intersection that would occur once the Furrow Road connection to Higby Road is established. The percentage splits representing the traffic shift to/from the south for Timberview and Hope Montessori traffic were calculated considering the trip destinations and origins, trip length distribution, and current road system (plus this Furrow extension).

The background traffic also includes estimates of traffic volumes by motorists that may utilize the connection as a through route (with no origin or destination between Higby and Highway 105). Through traffic may include traffic turning to/from Highway 105 or to/from Furrow north of Highway 105.

**TRIP GENERATION**

Estimates of the vehicle-trips projected to be generated by the Grandwood Ranch residential development have been made using the nationally published trip generation rates from *Trip Generation, 10<sup>th</sup> Edition, 2017* by the Institute of Transportation Engineers (ITE). Land use categories "210 – Single-Family Detached Housing," along with corresponding trip generation rates, have been used to develop the trip generation estimates for site buildout. The site plan, shown in Figure 2, shows 48 single-family lots within the proposed residential development.

Table 1 below presents a summary of the estimated site trip generation. A detailed trip generation estimate for the development, including ITE rates for the proposed land uses, is presented in Table 3 (attached).

The fitted curve ITE rates were used in the trip generation estimate. The R squared value is over 0.9 and the resulting estimate for the 48 lots was representative, and on the conservative side of representative, of the cluster of data points for subdivisions with about 50 dwelling units. LSC used the methodology in the ITE Handbook to select the appropriate rates.

The proposed Grandwood Ranch residential development is projected to generate about 600 vehicle-trips on the average weekday during a 24-hour period, with approximately half entering and half exiting the site. During the morning peak hour, approximately 10 entering vehicles and 29 exiting vehicles would be generated. Approximately 32 entering and 19 exiting vehicles would be generated by the site during the evening peak hour.

**Table 1: Estimated Site Vehicle-Trip Generation**

Analysis Period	Weekday		
	In	Out	Total
Morning Peak Hour	10	29	39
Evening Peak Hour	32	19	51
Daily/24-hour	265	265	529

## TRIP DISTRIBUTION AND ASSIGNMENT

### Trip Directional Distribution

Estimating the directional distribution of site-generated vehicle-trips to the study area roads and intersections is a necessary component in determining the site's traffic impacts. Figure 5 shows the percentages of the site-generated vehicle-trips projected to be oriented to and from the site's major approaches. Estimates have been based on the following factors: the proposed new land use, the area street and road system serving the site, and the site's geographic location relative to the City of Colorado Springs and unincorporated El Paso County.

Most land uses on Higby Road are residential, similar to the proposed Grandwood Ranch site. Existing vehicular turning movement counts were analyzed to determine directional splits for entering/exiting vehicles at the intersection of Higby Road/Furrow Road during both the morning and afternoon peaks.

Short-term analysis assumes that Furrow Road will be extended to the south to form a stop sign-controlled, T-intersection with Higby Road. Some vehicle-trips to/from west of the proposed Higby Road/Furrow Road intersection were thus shifted from Higby Road to Highway 105 to account for drivers who would opt to travel to the site via Highway 105 rather than Higby Road, which features challenging topography approaching the site.

Directional distributions were adjusted for the 2040 traffic scenarios to account for planned improvements on Highway 105, including the potential for signaling the intersection of Highway 105/Furrow Road (as shown in the *MTCP* and the *Highway 105 Corridor Study Corridor Preservation Study* (dated November 2013)). LSC has also completed several traffic studies near the proposed Grandwood Ranch site, which were used as a point of reference for estimating directional distributions.

The estimated significant differential between entering and exiting splits to the north is due to a few factors including the northbound left turn at Highway 105/Furrow for exiting trips and the location of the Interstate 25 southbound on ramp versus the reverse direction – a closer I-25 off ramp and an eastbound right turn onto Furrow from Highway 105. The future Gleneagle connection also factors into the difference short term and long term.

### **Site-Generated Traffic**

Site-generated traffic volumes at the following study area intersections have been calculated by applying the directional distribution percentages estimated by LSC (from Figure 5) to the trip generation estimates (from Table 3). Figure 6 and Figure 7 show the projected site-generated traffic volumes for the weekday morning and evening peak hours during the short- and long-term traffic scenarios, respectively.

- Highway 105/Furrow Road
- Furrow Road/Higby Road
- Higby Road/West Copper Valley Court/East Copper Valley Court
- Higby Road/Grandwood Court
- Higby Road/Fairplay Drive

### **Short-Term Total Traffic Volumes**

Figure 8 shows the sum of the short-term background traffic volumes (from Figure 4) and site-generated peak-hour traffic volumes (shown in Figure 6). These volumes represent the projected short-term total traffic following site buildout.

### **Estimated Future 2040 Background Traffic Volumes**

Figure 9 shows the projected 20-year background traffic volumes for the year 2040. Estimated 2040 background traffic volumes on Highway 105, Furrow Road, and Higby Road are based on projected 2040 volumes in the *MTCP* and the *Highway 105 Corridor Study Corridor Preservation Study* (dated November 2013). Background traffic volumes do **not** include projected traffic to be generated by the proposed Grandwood Ranch residential development.

The short-term background traffic volumes were used as a starting point for developing the 2040 background traffic volumes, as the short-term estimates estimate the initial change in travel patterns with the new segment available between Higby and Highway 105. The long-term volumes account for the continuous through connection between Gleneagle & Furrow.

### **Future 2040 Total Traffic Volumes**

Figure 10 shows the projected 2040 total traffic volumes, which are the sum of 2040 background traffic volumes (from Figure 9) plus the site-generated traffic volumes (from Figure 7).

## LEVEL OF SERVICE ANALYSIS

The following study area intersections have been analyzed to determine the projected intersection levels of service for short- and long-term traffic scenarios for the morning and evening peak-hour time periods:

- Highway 105/Furrow Road
- Furrow Road/Higby Road
- Higby Road/West Copper Valley Court/East Copper Valley Court
- Higby Road/Grandwood Court
- Higby Road/Fairplay Drive

Level of service (LOS) is a quantitative measure of the level of congestion or delay at an intersection and is indicated on a scale from "A" to "F." LOS A is indicative of little congestion or delay. LOS F indicates a high level of congestion or delay. Table 2 shows the level of service delay ranges for signalized and unsignalized intersections.

Table 2: Intersection Levels of Service Delay Ranges

Level of Service	Signalized Intersection (Seconds/Vehicle)	Unsignalized Intersection (Seconds/Vehicle)
A	≤ 10.0	≤ 10.0
B	10.1 - 20.0	10.1 - 15.0
C	20.1 - 35.0	15.1 - 25.0
D	35.1 - 55.0	25.1 - 35.0
E	55.1 - 80.0	35.1 - 50.0
F	≥ 80.1	≥ 50.1

<sup>1</sup> For unsignalized intersections, if  $v/c \geq 1.0$ , then LOS is LOS F, regardless of the projected average control delay per vehicle

### Short-Term LOS

A summary of LOS for all short-term traffic scenarios during the weekday morning and evening peak hours is shown in Figure 4 and Figure 8. Detailed Synchro reports are attached.



As shown in these figures, all individual turning movements/intersection approaches at the following intersections are projected to operate at LOS C or better during both peak periods upon site buildout in the short term:

- Furrow Road/Higby Road
- Higby Road/West Copper Valley Court/East Copper Valley Court
- Higby Road/Grandwood Court
- Higby Road/Fairplay Drive

The intersection of Highway 105/Furrow Road is projected to remain stop sign-controlled in the short term, with no modifications to existing turn lane geometries. The northbound shared through/left turn lane is projected to operate at LOS F during both peak hours during the short term, **regardless of whether or not Grandwood Ranch is developed.**

### Long-Term LOS

A summary of LOS for all long-term traffic scenarios during the weekday morning and evening peak hours is shown in Figure 9 and Figure 10. Detailed Synchro reports are attached.

As shown in these figures, all individual turning movements/intersection approaches at the following intersections are projected to operate at LOS D or better during both peak periods upon site buildout in the short term with two-way stop sign control (TWSC):

- Furrow Road/Higby Road
- Higby Road/West Copper Valley Court/East Copper Valley Court
- Higby Road/Grandwood Court
- Higby Road/Fairplay Drive

The following turning movements are projected to operate at LOS F during both the morning and evening peak hours for the 2040 total traffic scenario if the intersection of Highway 105/Furrow Road were to remain stop sign-controlled:

- Northbound left
- Northbound shared through/right
- Southbound left
- Southbound through

However, all individual turning movements are projected to operate at LOS D or better during both peak hours through the 2040 horizon year if the intersection of Highway 105/Furrow Road were to be signalized.

The intersection of Highway 105/Furrow Road will likely be converted from a stop sign-controlled intersection to a signalized intersection by 2040, as shown in the *Highway 105 Corridor Study Corridor Preservation Study* (dated November 2013). Additional recommended improvements to the intersection include exclusive left-, through, and right-turn lanes for the southbound approach on Furrow Road and conversion of the northbound approach to an exclusive left-turn lane and a shared right/through turn lane. **These modifications to the intersection of Highway**

**105/Furrow Road were recommended regardless of whether or not Grandwood Ranch is developed.**

### AUXILIARY TURN LANE ANALYSIS

According to the El Paso County *Engineering Criteria*

- Exclusive left-turn lanes shall be provided for a projected peak-hour ingress turning volume
- Exclusive right-turn lanes shall be provided for a projected peak-hour ingress turning volume

#### Short Term

Projected eastbound short-term background (and Higby Road/Furrow Road are projected to exceed outlined in the *ECM* with the extension of Furrow Road projections). Thus, an exclusive eastbound left-turn intersection. A concept for the design of this turn lanes is included with this report.

The cost to install this auxiliary turn lane should be an eligible intersection improvement. If the applicant constructs this turn lane along with the Furrow Road extension, the applicant should be eligible for credit, based on standard unit costs per the fee program rules.

A westbound right-turn lane would **not** be required at the intersections of Higby Road/Furrow Road or Higby Road/Grandwood Court in the short term, based on projected turning movement volumes at each intersection. Additionally, auxiliary turn lanes would **not** be required at the site access point intersection (Copper Valley Court/Furrow Road).

#### Long Term

El Paso County's *MTCP* shows the planned Gleneagle to Furrow connection across Higby Road and through this site. Estimates of peak hour turning movements indicate that the intersections of Higby Road/Furrow Drive and Higby Road/Grandwood Court will potentially require the installation of exclusive right- and additional left-turn auxiliary turn lanes once road connections to the north and south of Higby (and to the south of Higby in the case of the Grandwood Court intersection) are built and associated residential developments are completed, **regardless of whether or not Grandwood Ranch is developed.**

The required total auxiliary lane length for the proposed eastbound left-turn lane on Higby Road at its proposed access with Furrow Road is 365 feet, consisting of 205 feet of full-width lane length and a 160-foot approach taper, with adjustments to account for roadway grades, as needed.

Update the TIS to outline the process the applicant will need to do to initiate and memorialize the eligible improvements. The applicant needs to be aware that this is initiated by the developer, not PCD. Acceptance of this TIS as part of this project does not constitute an agreement that said improvements will be considered eligible improvements. Determination for eligible improvements is through the road impact fee committee.

Staff recommends the applicant submits a road impact fee credit agreement to Victoria Chavez concurrent with this application. Verify actual application timing with Victoria.

Per the *Engineering Criteria Manual*, potential auxiliary turn lanes on Higby Road are shown in Figure 9 and Figure 10. Auxiliary turn lanes would **not** be required at the site access point intersection (Copper Valley Court/Furrow Road).

## **SIGHT DISTANCE ANALYSIS**

### **ECM Requirements**

Planned public roadway intersections must meet *ECM* standards for sight distance contained in Section 2.4.1.D.2 of the *ECM*. Intersections are anticipated to be stop sign-controlled, full-movement intersections.

Based on the spot-grades along Higby Road east of the proposed intersection of Higby/Furrow, the prescribed stopping sight distance is 333 feet (downgrade of approximately six percent).

All sight distance field measurements utilized a driver's eye height of 3.5 feet and a height of 3.5 feet for an eastbound vehicle approaching from the west. The following analysis corresponds to field-measured sight distances for the proposed intersection of Higby/Furrow and east Grandwood Ranch site access (Grandwood Court), as shown in Figure 12.

#### Proposed Higby Road/Furrow Road Intersection

Field-measured sight distances for passenger vehicles are as follows:

- To the west: 1,250 feet
- To the east: 650 feet

#### Proposed Higby Road/Grandwood Court

Field-measured sight distances for passenger vehicles are as follows:

- To the west: 645 feet
- To the east: 1,990 feet

#### Proposed Access to Furrow Road (Extended)

Based on the plan and profile design drawings, the sight distance at the proposed intersection of Copper Valley Court/Furrow Road would exceed 800 feet to the north and 600 feet to the south along Furrow Road. The intersection and stopping sight distance would meet county standards for a design speed of 40 mph.

### **Comparison to ECM Sight Distance Standards**

With a 35-mph posted speed limit on Higby Road (assumed design speed of 40 mph), the field-measured sight distances for both the proposed intersection of Higby/Furrow and east

Grandwood Ranch site access (Grandwood Drive) would exceed the required 445-foot requirement for passenger vehicles shown in ECM Table 2-21.

The requirement of 455 feet for single-unit trucks would be met as well, with the driver's eye being significantly higher than 3.5 feet for single unit trucks. Therefore, access entering sight distance at both access intersections on Higby Road (with Furrow Road and Grandwood Court, respectively) **would** be acceptable at their proposed locations shown on the site plan. If the access is planned for regular use by multi-unit trucks, the sight distance should be verified for this design vehicle.

### **HIGBY ROAD & FURROW ROAD GRADES**

The existing grade on the proposed westbound approach to the Higby Road/Furrow Road intersection is 6.5 percent.. West of the proposed intersection, the grades moderate for the eastbound intersection approach.

### **ROADWAY CLASSIFICATIONS**

The recommended roadway classifications for the subdivision are shown in Figure 11. This figure also shows roadway classifications for Higby Road, Furrow Road and Fairplay Drive per the *MTCP* 2040 Plan.

### **LIST OF DEVIATIONS REQUESTED**

A list of deviation requests is presented in Figure 13. Three deviation request forms have been prepared.

*ECM* Appendix B requires traffic studies to, "State whether the *MTCP* or other approved corridor study calls for the construction of improvements in the immediate area." The *MTCP* identifies the following:

- Furrow Road extension (Lamplighter to Higby) is shown in the *MTCP* as an Urban two-lane Collector ("New Road Connection")
- Higby Road (Cloverleaf Road to Roller Coaster Road) as an **Urban** two-lane Minor Arterial ("County Road Upgrade")

### **COUNTY ROAD IMPROVEMENT FEE PROGRAM**

#### **Transportation Impact Fees**

Per *ECM* Appendix B: *State what the current applicable Transportation Impact Fees are and what option the developer will be selecting for payment.*

The applicant is opting out of the PID options and will pay the full fee amount at the time of building permit. The 2010 full-fee single family residential housing rate is \$3,830 per dwelling unit. The total fee amount for 48 single family dwelling units is \$183,840.

### **Reimbursable Improvements**

Furrow Road extension and the Furrow/Higby Intersection should both be reimbursable under the MTCP. The cost to install this auxiliary turn lane should be an eligible intersection improvement and if the applicant constructs this turn lane along with the Furrow Road extension, the applicant should be eligible for credit, based standard unit costs per the fee program rules.

### **PROJECT IMPACT AT HIGHWAY 105/FURROW ROAD INTERSECTION**

The Grandwood Ranch project traffic is estimated to represent a 7.5 percent increase in morning peak hour traffic northbound approach traffic at the Highway 105/Furrow intersection and a 5.3 percent increase in the afternoon peak hour northbound approach traffic at this intersection. An escrow for a potential future traffic signal at this intersection should not be required as this intersection likely meets the criteria contained in the Fee program implementation document for an "eligible intersection."

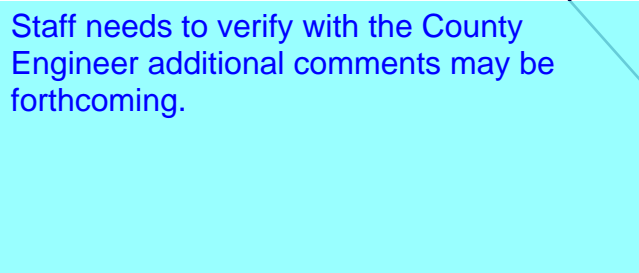

Staff needs to verify with the County Engineer additional comments may be forthcoming.

## MULTI-MODAL TRANSPORTATION & TDM OPPORTUNITIES

The Rural Local roadways proposed for the project will carry low traffic volumes and thus will be suitable for pedestrians and bicycles. Furrow Road will be constructed to Rural Collector standards, which includes a paved shoulder suitable for cyclists.

## IMPROVEMENTS SUMMARY TABLE

Please refer to Table 3, which presents a summary of improvements.

## CONCLUSIONS

- The site is projected to generate about 550 new driveway vehicle-trips on the average weekday.
- During the weekday morning peak hour of adjacent street traffic, 10 vehicles would enter the site while 30 vehicles would exit.
- During the weekday evening peak hour of adjacent street traffic, 33 vehicles would enter the site while 19 vehicles would exit.
- All individual turning movements and approaches at the adjacent and site access intersections are projected to operate at LOS D or better during both peak hours through the 2040 horizon year.
- An eastbound left turn lane is projected to be warranted per ECM criteria the planned intersection of Higby/Furrow. Turn lanes would not be needed at the site access point intersections. Please refer to the "Auxiliary Turn Lane Analysis" section and Table 5 for more detail on turn lane requirements.
- A list of deviations is presented in Figure 13.
- LSC recommends that both site access point intersections be stop sign controlled.

\* \* \* \* \*

The NBLT on Furrow/Hwy 105 is unlikely to occur in the near future as part of the DPW's capital improvement projects for Hwy 105. Grandwood Ranch will be complete before improvements to Hwy 105 at this intersection occurs.

Update the conclusion to include a recommendation for addressing the LOS F at the intersection of Furrow and Hwy 105 based on this projects impact.

It seems that this should improved by the developer for safe operations as part of the traffic impact caused by the development of Grandwood Ranch.

Staff has requested input from the County Engineer. Additional comments DPW/County Engineer is forthcoming.

Please contact me if you have any questions regarding this report.

Respectfully Submitted,

LSC TRANSPORTATION CONSULTANTS, INC.

By: Jeffrey C. Hodsdon, P.E.  
Principal

JCH/JAB:jas

Enclosures: Table 3  
Figure 1 – Figure 11  
Traffic Count Reports  
Level of Service Reports

**Table 3: Detailed Trip Generation Estimate**

ITE		Value	Units	Trip Generation Rates <sup>(1)</sup>				Total Trips Generated					
Code	Description			Average	A.M.		P.M.		Average	A.M.		P.M.	
				Weekday	In	Out	In	Out	Weekday	In	Out	In	Out
210	Single-Family Detached Housing	48	DU	11.03	0.20	0.61	0.66	0.39	529	10	29	32	19
(1) DU = dwelling units (2) Source: Trip Generation, 10th Edition, 2017, by the Institute of Transportation Engineers (ITE)													



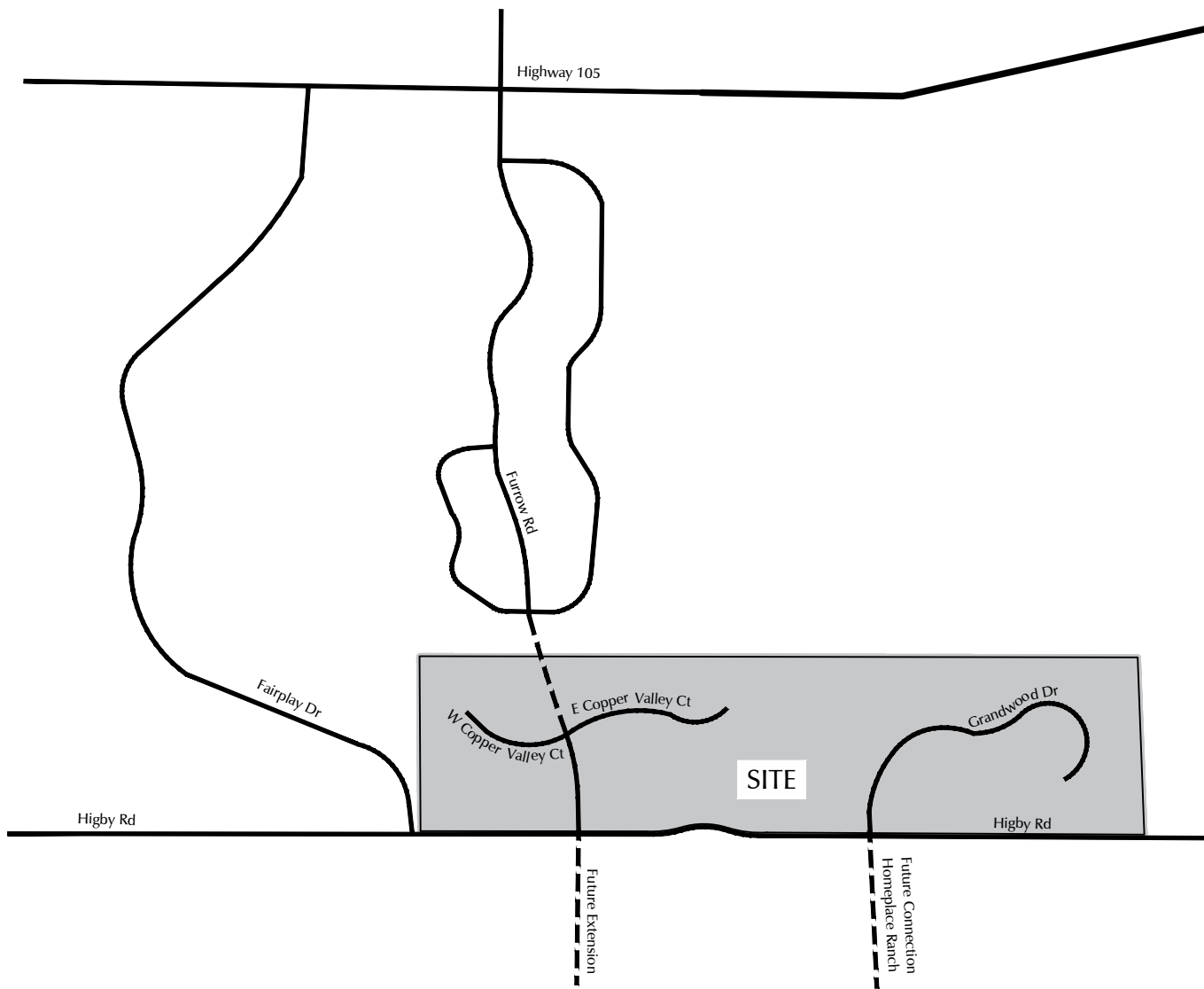

Figure 1  
**Vicinity Map**  
Grandwood Ranch (LSC# 185020)

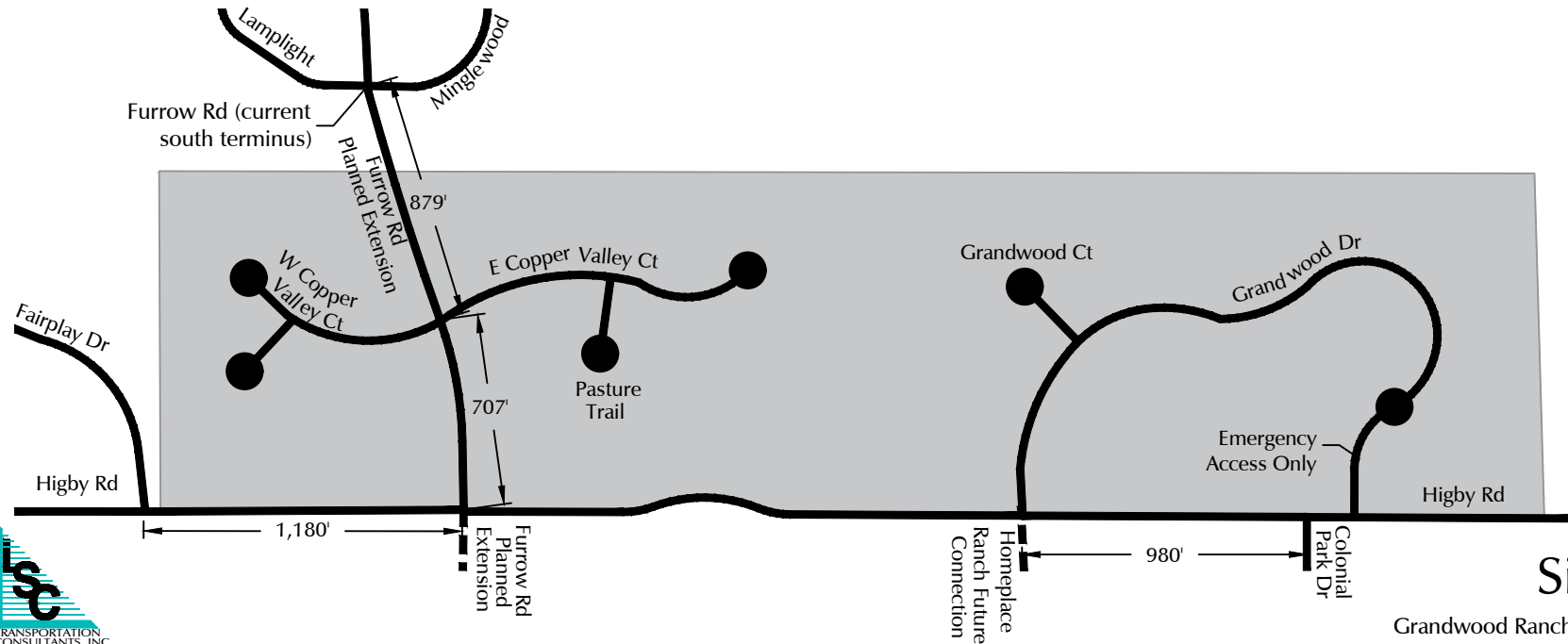
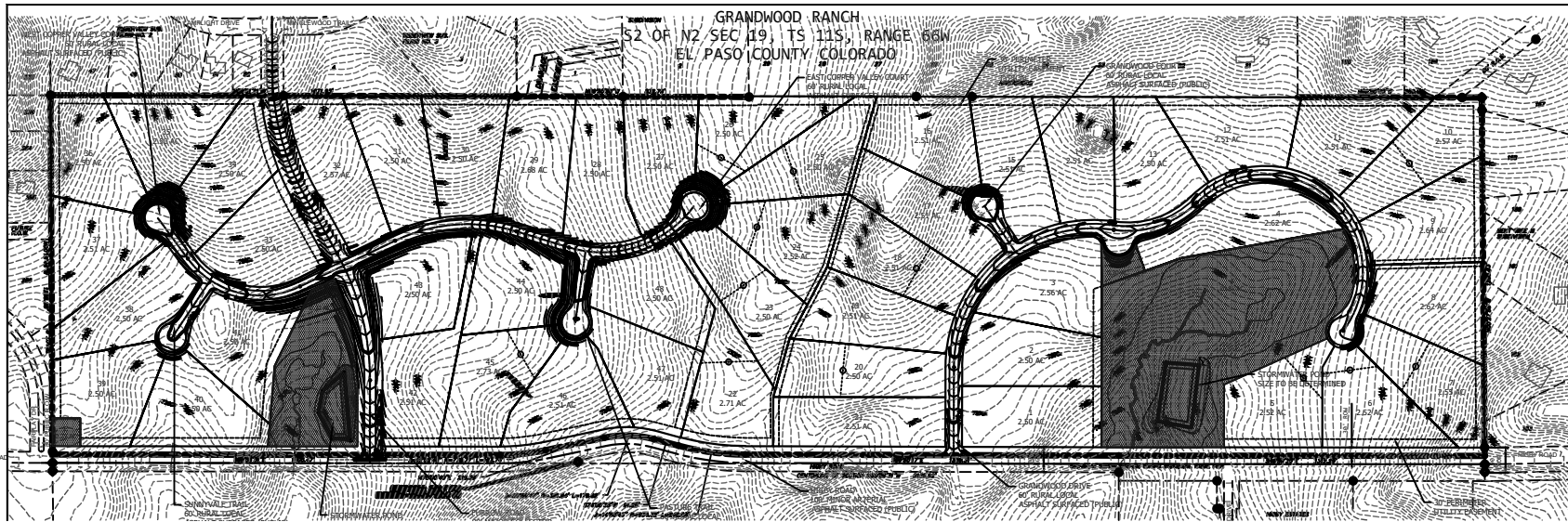
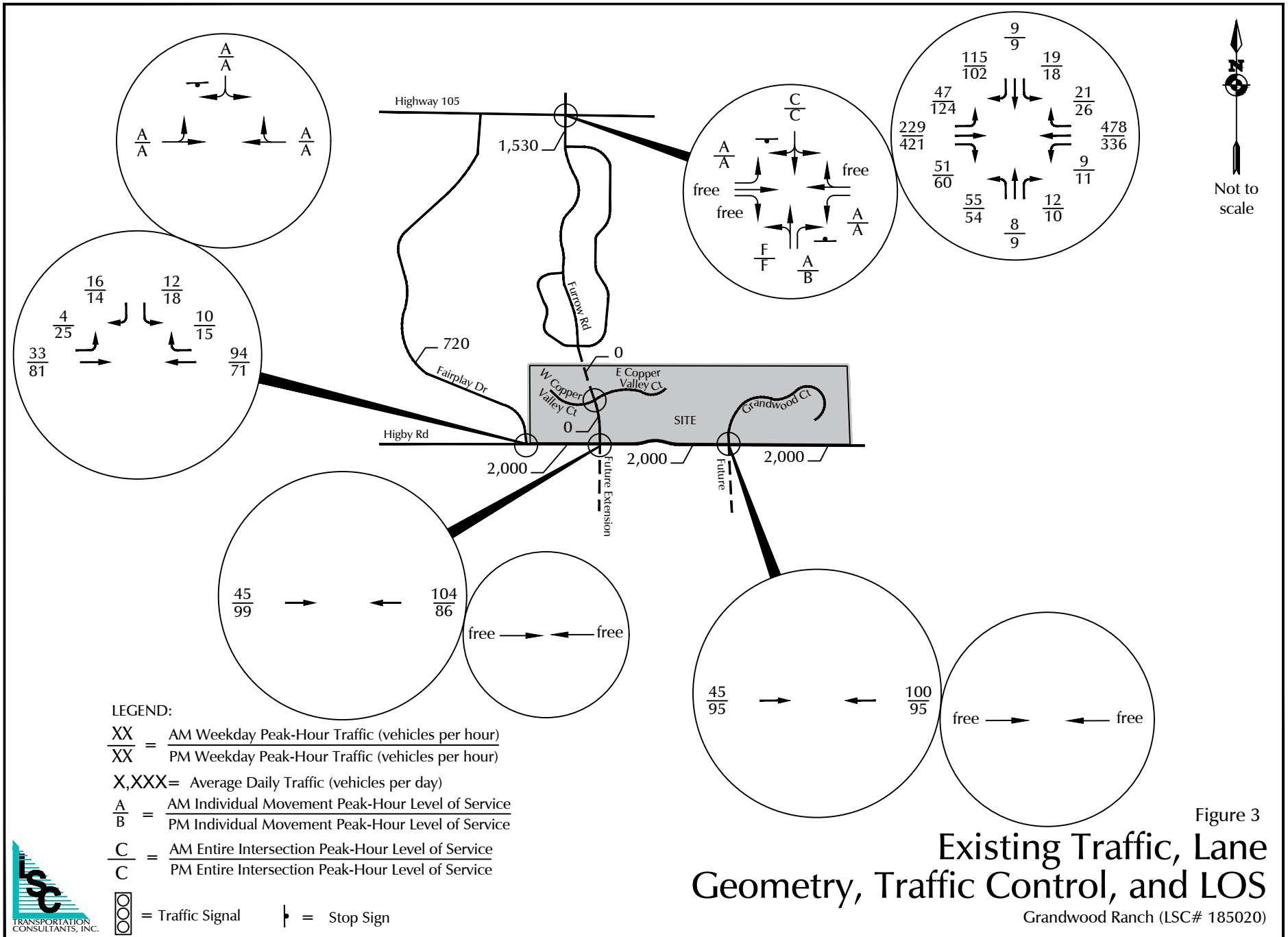

Figure 2

# Site Plan

Grandwood Ranch (LSC# 185020)





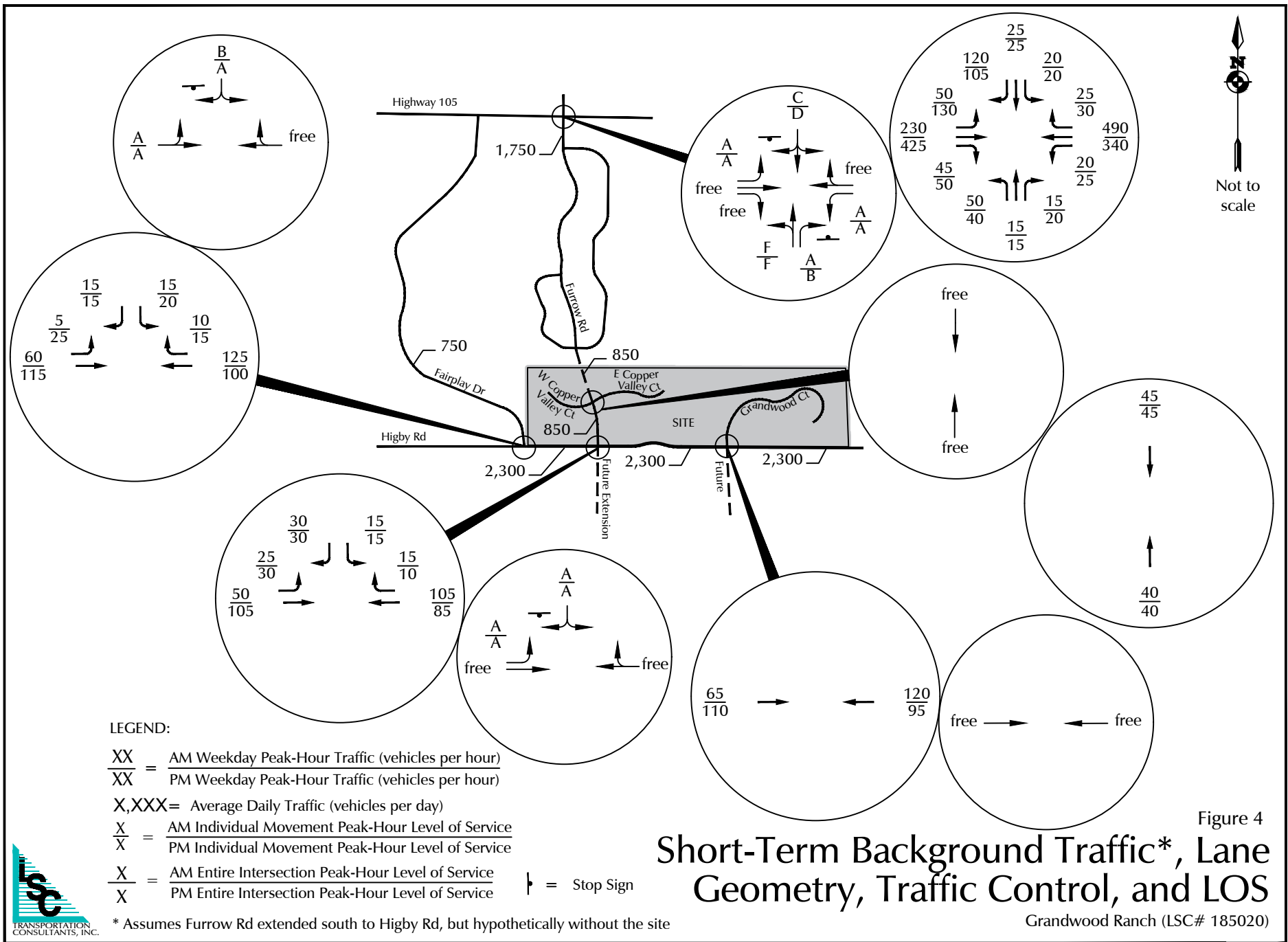

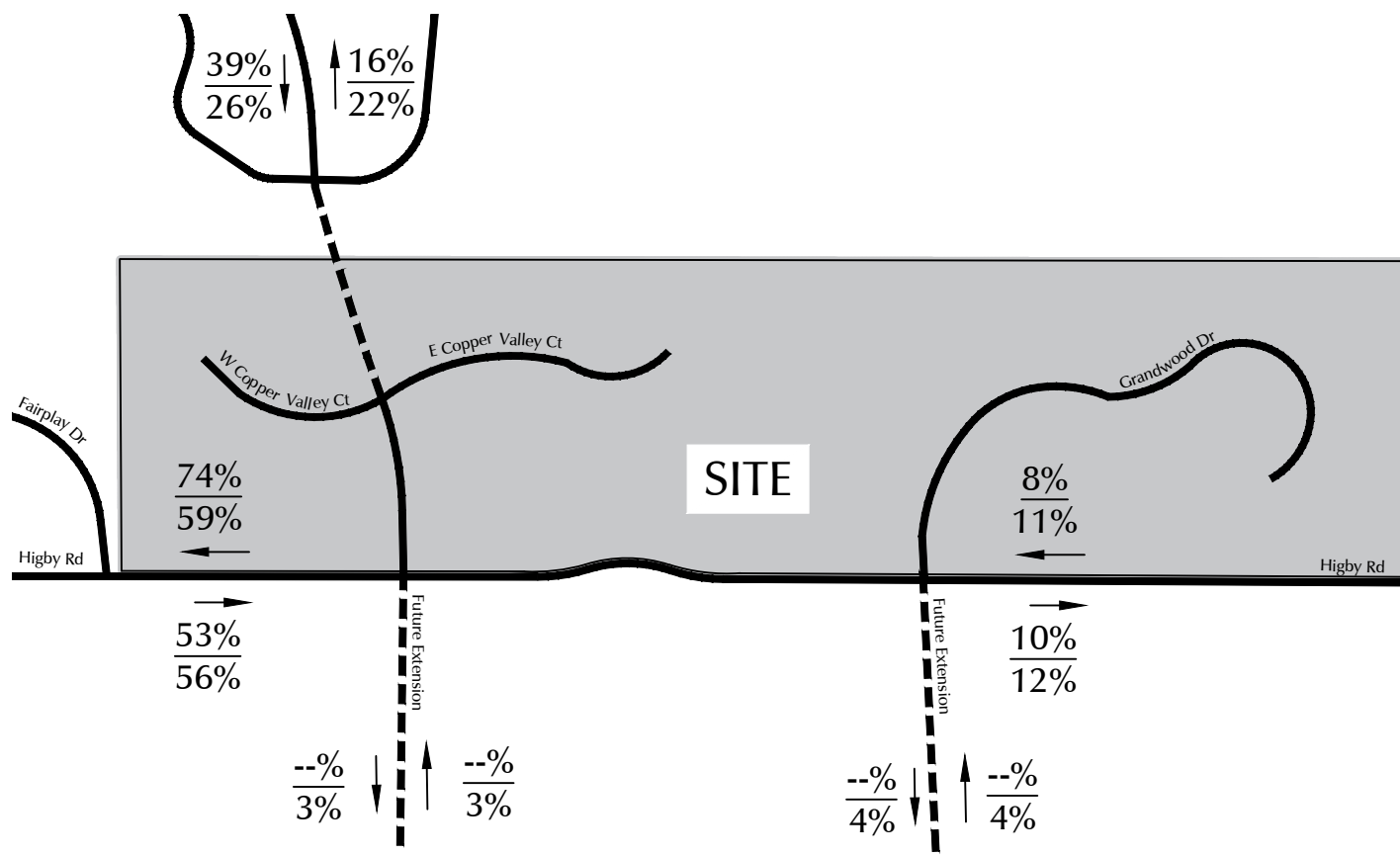

LEGEND:  
 $\frac{XX\%}{XX\%} = \frac{\text{Short-Term Distribution}}{\text{Long-Term Distribution}}$

Figure 5  
**Estimated Directional Distribution**  
 Grandwood Ranch (LSC# 185020)



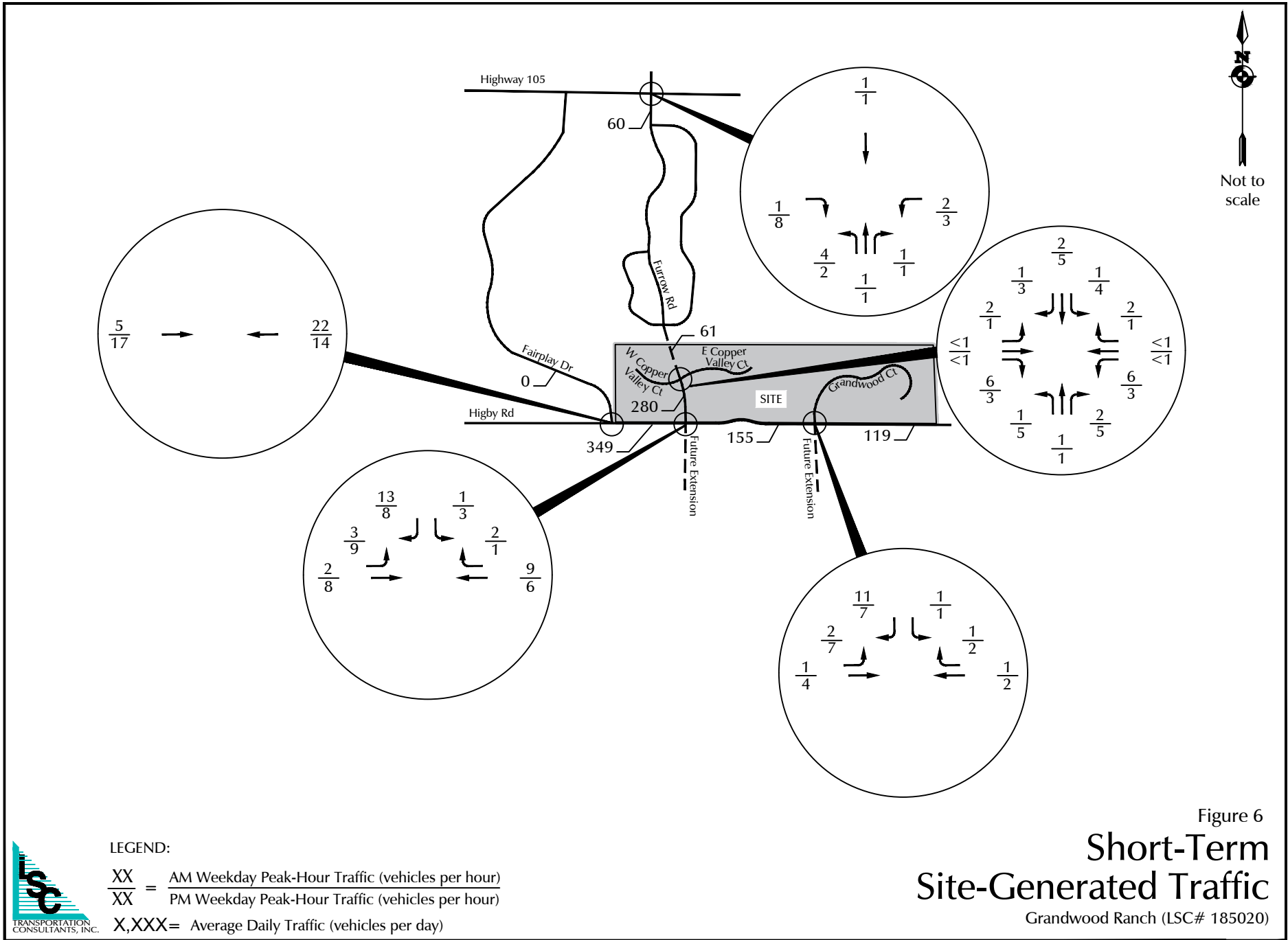



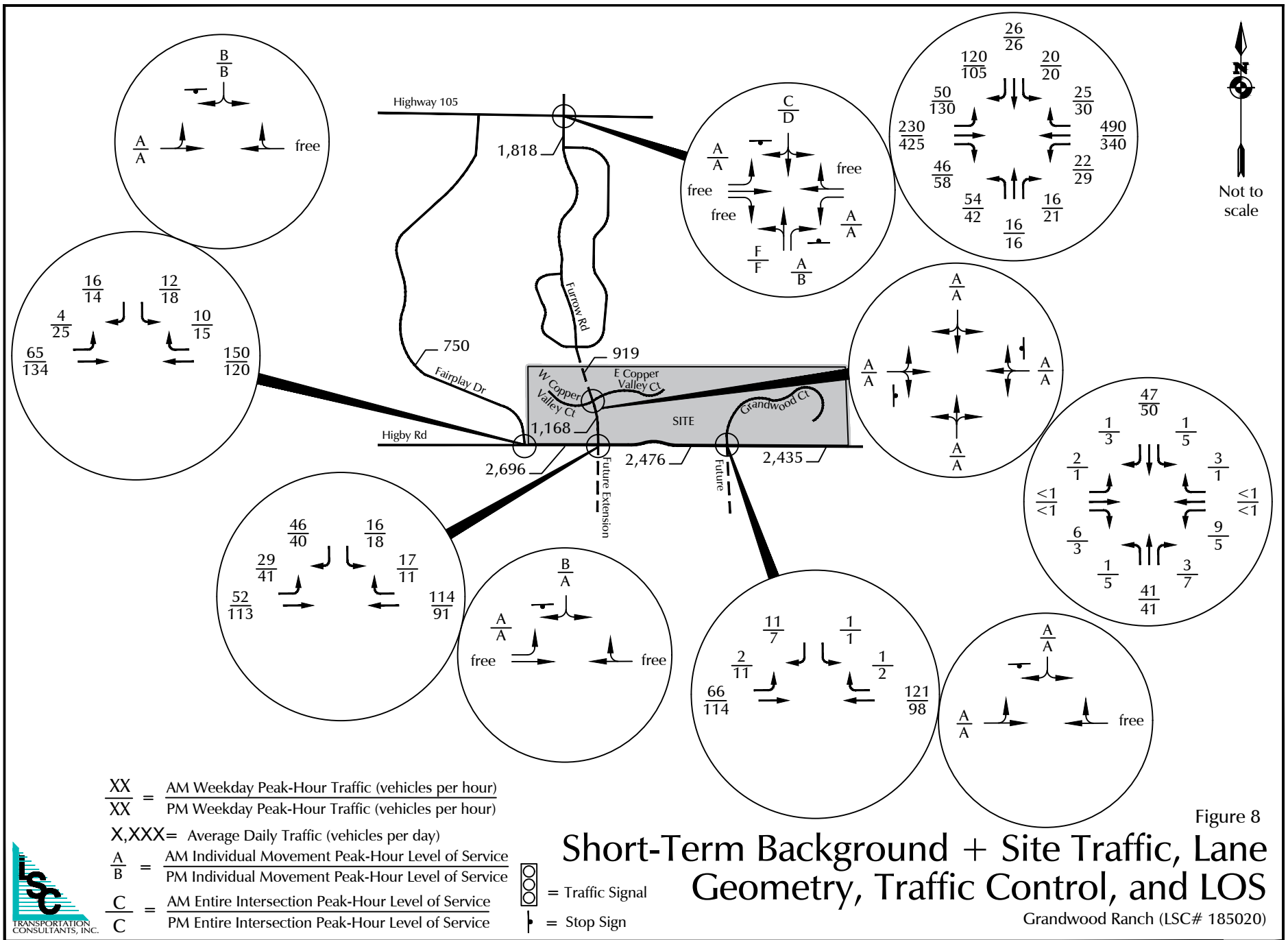



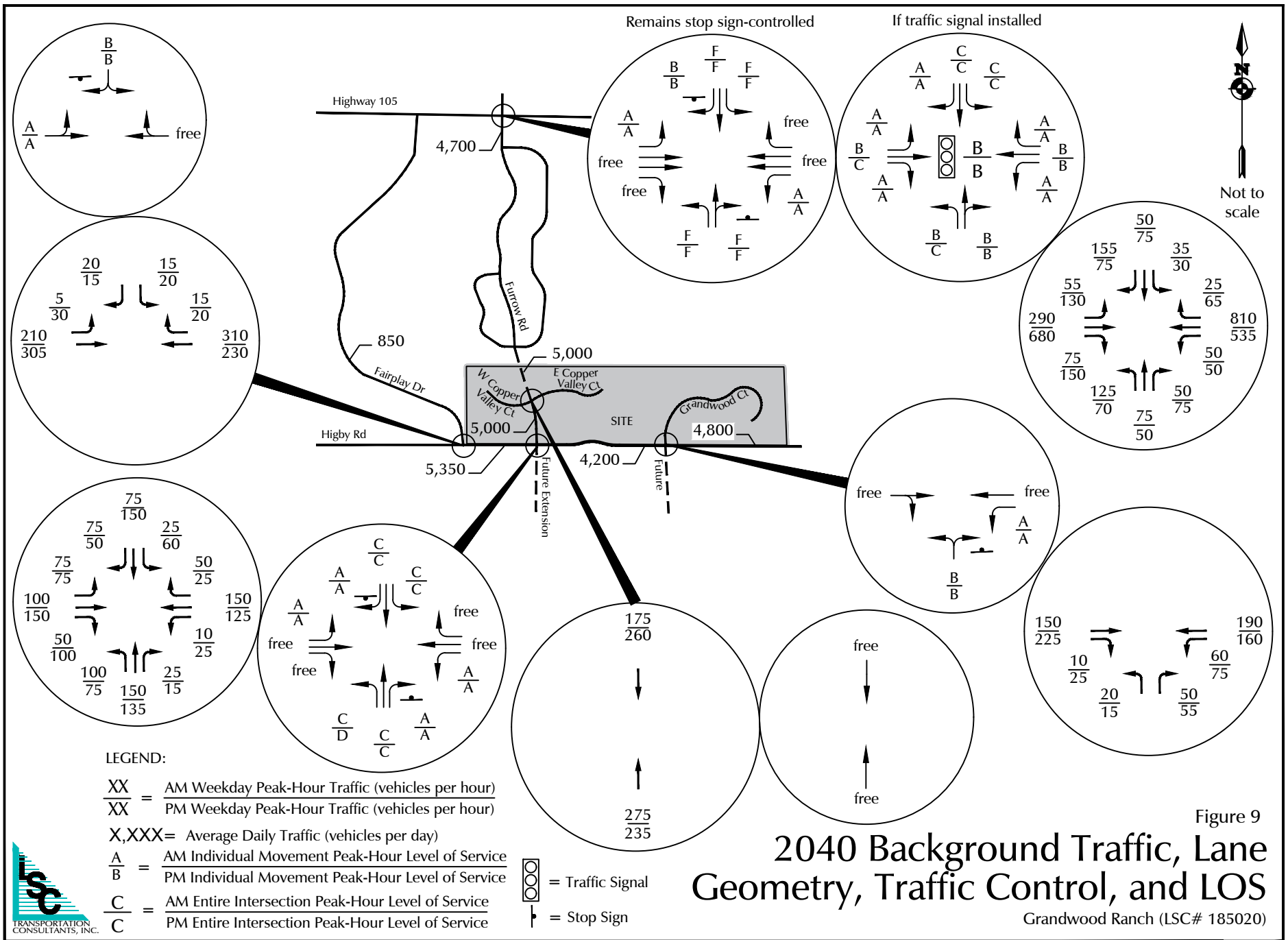
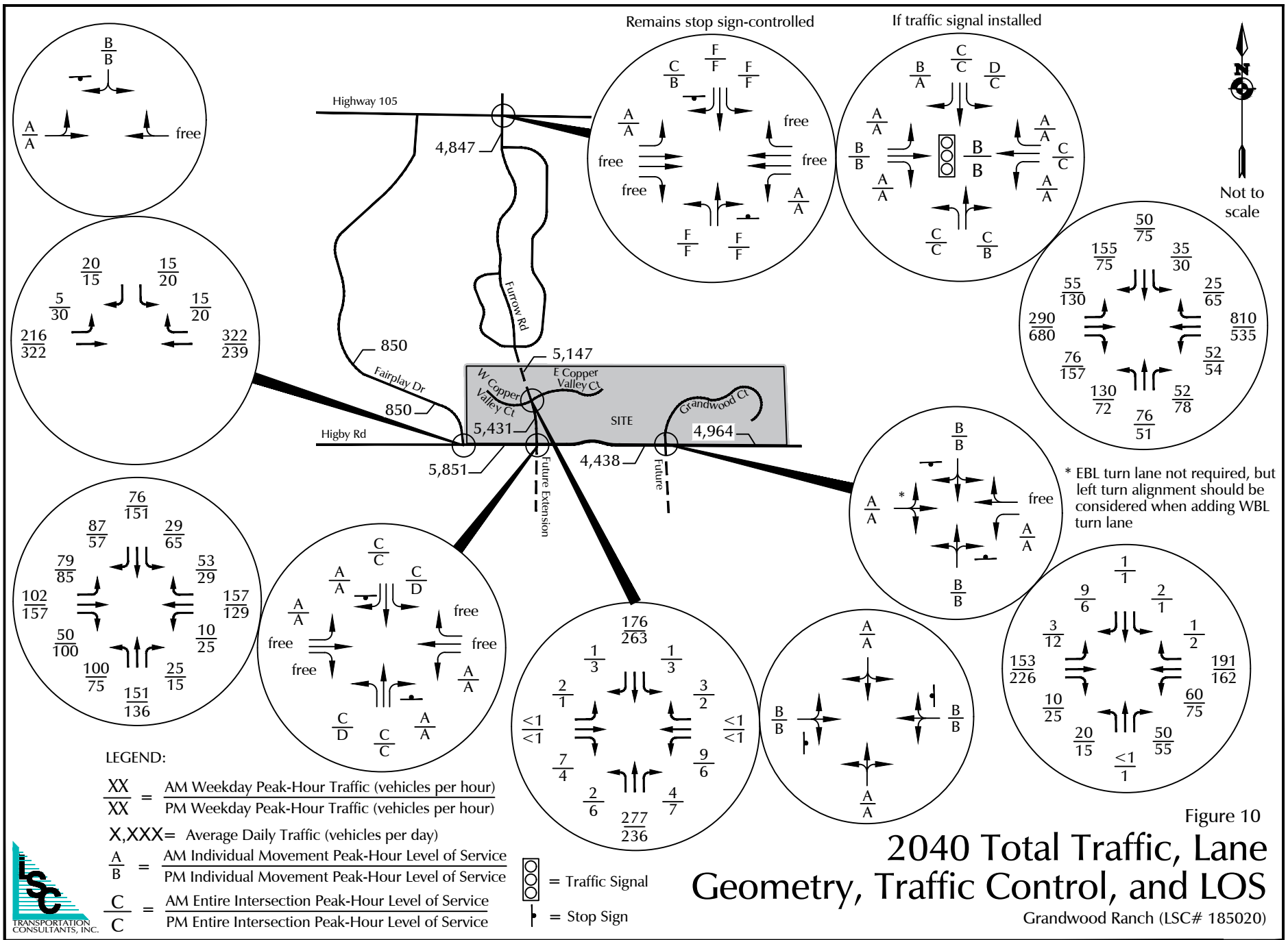

Figure 9  
**2040 Background Traffic, Lane  
 Geometry, Traffic Control, and LOS**  
 Grandwood Ranch (LSC# 185020)



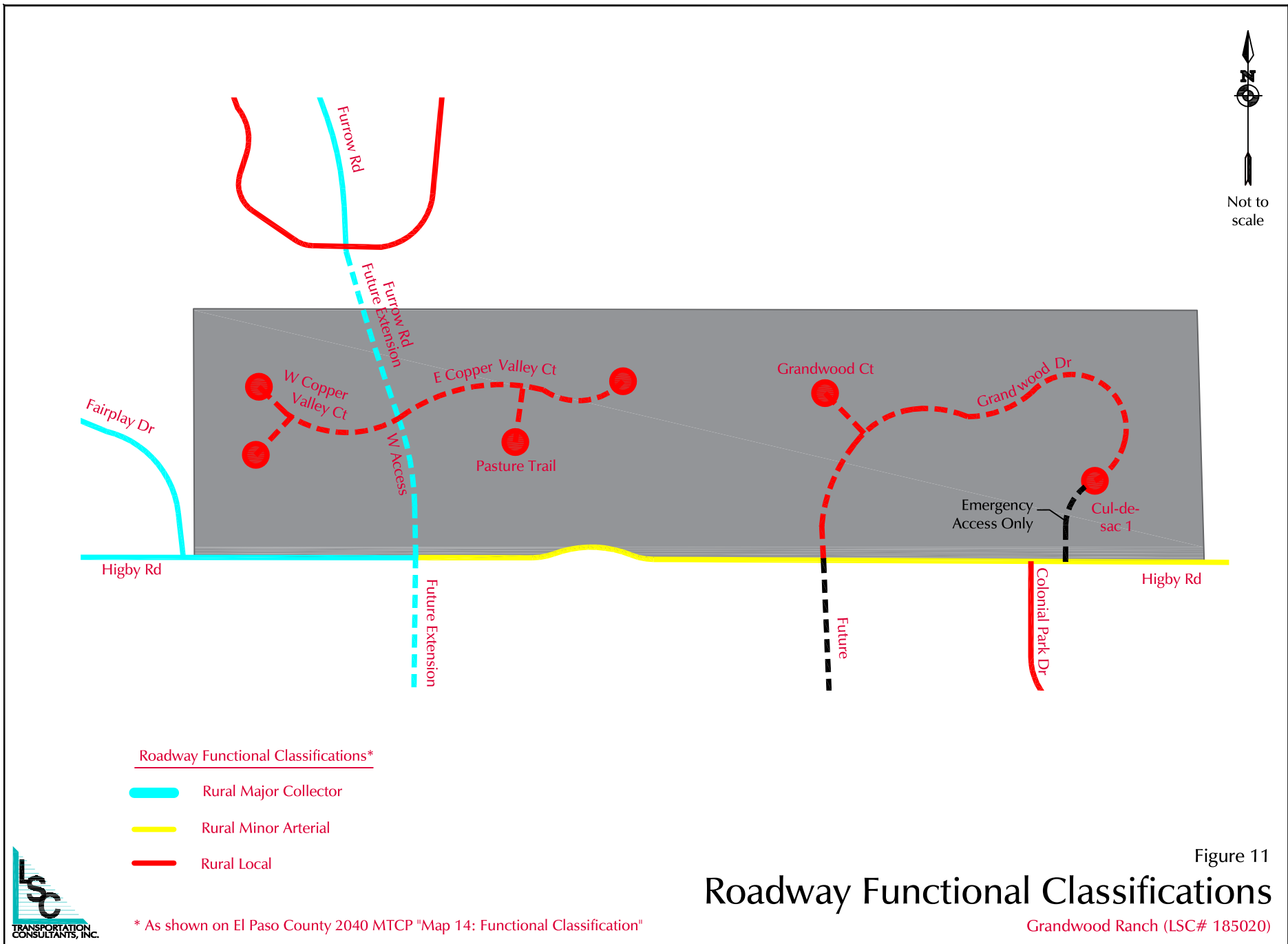

Figure 11  
**Roadway Functional Classifications**

Grandwood Ranch (LSC# 185020)





Not to scale

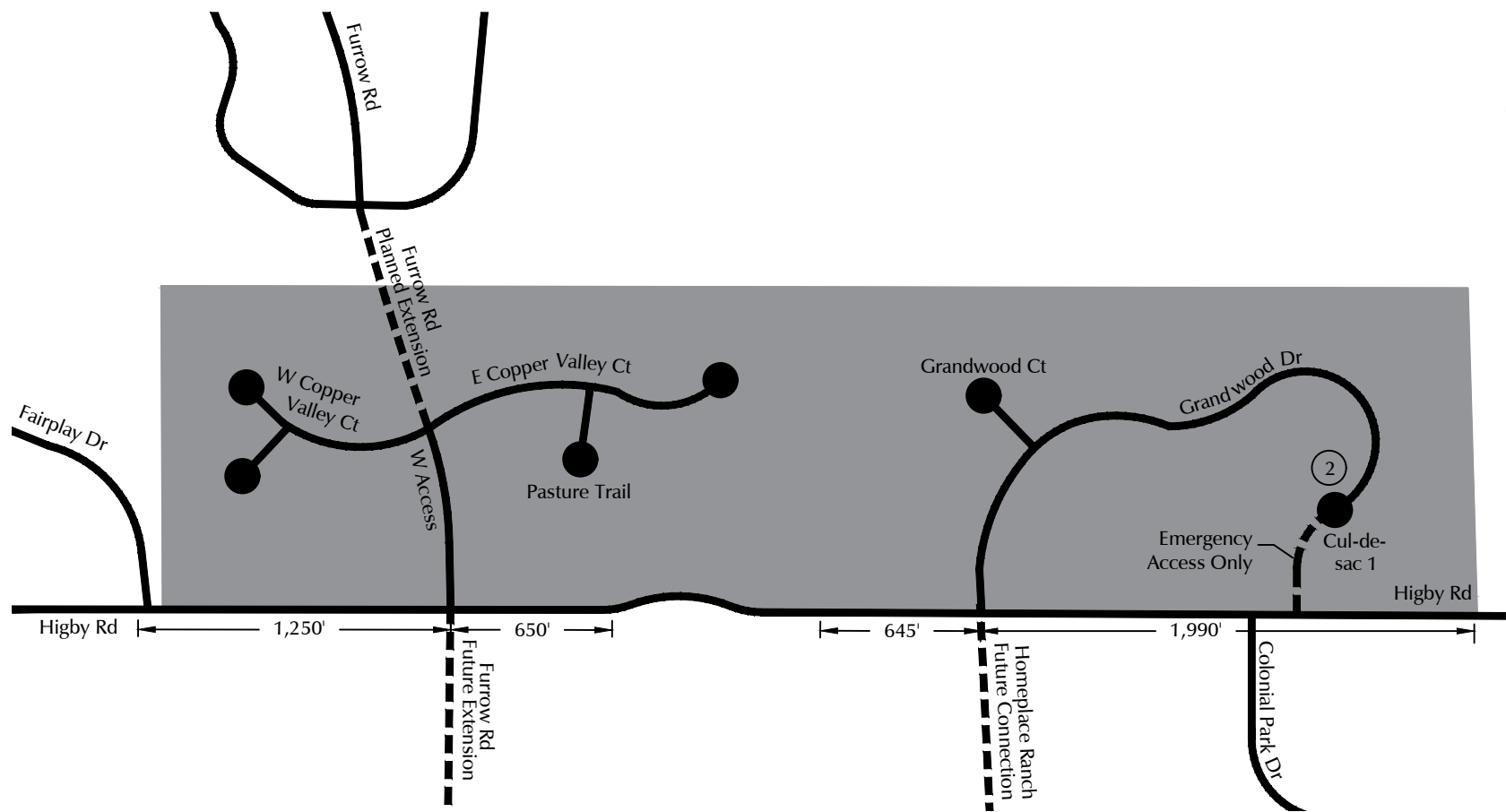

Site property boundary

Sight distance E or W of proposed access relative to centerline of intersection



Figure 12  
**Sight Distances**  
Grandwood Ranch (LSC# 185020)



Not to scale

ECM Standard Deviation Requests

- ① 2.2.5.D -- Roadway Access Criteria (Rural Major Collector)
- ② 2.2.5.B -- Roadway Access Criteria (Rural Minor Arterial)
- ③ 2.3.8.A -- Roadway Terminations (Rural Cul-de-Sac)
- ④ 2.3.7.C.4 -- Vertical Intersection Alignment
- ⑤ 2.3.B.4 -- Maximum and Minimum Grades for Roadways
- ⑥ 2.3.2 -- Design Standards by Functional Classification

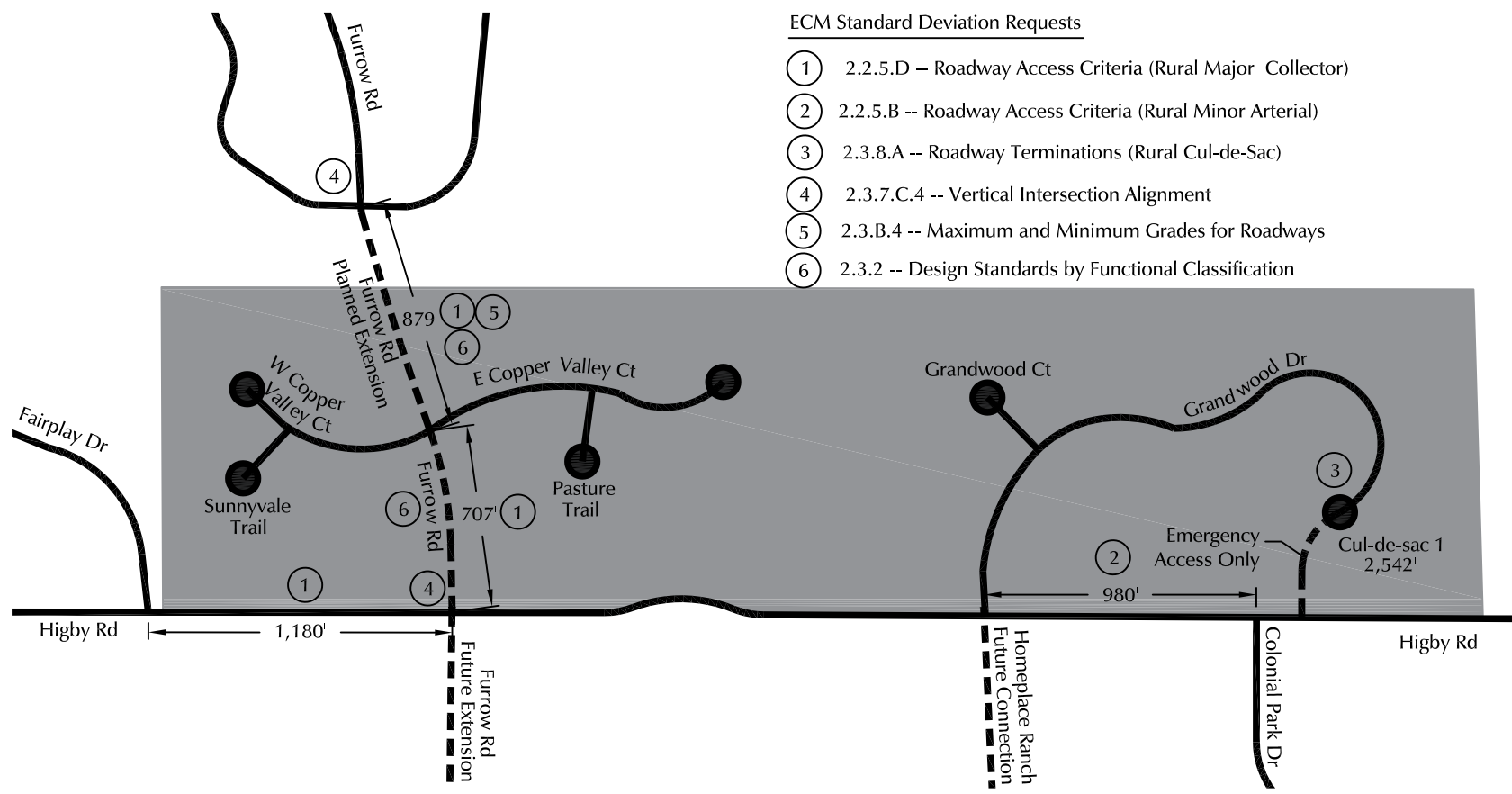

- Site property boundary
- Distance between center of intersection to Higby Rd
- Distance between center of cul-de-sac to Higby Rd



Figure 13  
**Requested Deviations**  
 Grandwood Ranch (LSC# 185020)





# LSC Transportation Consultants, Inc.

545 E Pikes Peak Ave, Suite 210  
 Colorado Springs, CO 80905  
 719-633-2868

File Name : Furrow Rd - Hwy 105 AM  
 Site Code : 185020  
 Start Date : 8/27/2019  
 Page No : 1

### Groups Printed- Unshifted

Start Time	Furrow Rd Southbound					Hwy 105 Westbound					Furrow Rd Northbound					Hwy 105 Eastbound					Int. Total
	Left	Through	Right	Peds	App. Total	Left	Through	Right	Peds	App. Total	Left	Through	Right	Peds	App. Total	Left	Through	Right	Peds	App. Total	
06:30 AM	3	0	24	0	27	3	62	4	0	69	12	2	3	0	17	2	32	4	0	38	151
06:45 AM	3	1	23	0	27	5	82	7	0	94	13	2	1	0	16	4	29	8	0	41	178
Total	6	1	47	0	54	8	144	11	0	163	25	4	4	0	33	6	61	12	0	79	329
07:00 AM	2	1	26	0	29	3	125	10	0	138	10	2	3	0	15	7	57	9	0	73	255
07:15 AM	5	0	38	0	43	1	129	4	0	134	21	1	4	0	26	12	61	14	0	87	290
07:30 AM	8	5	33	0	46	1	116	2	0	119	16	2	3	0	21	11	60	7	0	78	264
07:45 AM	4	3	18	0	25	4	108	5	0	117	8	3	2	0	13	17	51	21	0	89	244
Total	19	9	115	0	143	9	478	21	0	508	55	8	12	0	75	47	229	51	0	327	1053
08:00 AM	3	0	17	0	20	4	64	5	0	73	17	3	4	0	24	10	59	15	0	84	201
08:15 AM	4	2	23	0	29	4	59	2	0	65	12	1	6	0	19	17	47	11	0	75	188
Grand Total	32	12	202	0	246	25	745	39	0	809	109	16	26	0	151	80	396	89	0	565	1771
Apprch %	13	4.9	82.1	0		3.1	92.1	4.8	0		72.2	10.6	17.2	0		14.2	70.1	15.8	0		
Total %	1.8	0.7	11.4	0	13.9	1.4	42.1	2.2	0	45.7	6.2	0.9	1.5	0	8.5	4.5	22.4	5	0	31.9	



# LSC Transportation Consultants, Inc.

545 E Pikes Peak Ave, Suite 210  
 Colorado Springs, CO 80905  
 719-633-2868

File Name : Furrow Rd - Hwy 105 AM  
 Site Code : 185020  
 Start Date : 8/27/2019  
 Page No : 2

Start Time	Furrow Rd Southbound					Hwy 105 Westbound					Furrow Rd Northbound					Hwy 105 Eastbound					Int. Total
	Left	Through	Right	Peds	App. Total	Left	Through	Right	Peds	App. Total	Left	Through	Right	Peds	App. Total	Left	Through	Right	Peds	App. Total	
<b>Peak Hour Analysis From 06:30 AM to 08:15 AM - Peak 1 of 1</b>																					
Peak Hour for Entire Intersection Begins at 07:00 AM																					
07:00 AM	2	1	26	0	29	3	125	10	0	138	10	2	3	0	15	7	57	9	0	73	255
07:15 AM	5	0	38	0	43	1	129	4	0	134	21	1	4	0	26	12	61	14	0	87	290
07:30 AM	8	5	33	0	46	1	116	2	0	119	16	2	3	0	21	11	60	7	0	78	264
07:45 AM	4	3	18	0	25	4	108	5	0	117	8	3	2	0	13	17	51	21	0	89	244
Total Volume	19	9	115	0	143	9	478	21	0	508	55	8	12	0	75	47	229	51	0	327	1053
% App. Total	13.3	6.3	80.4	0		1.8	94.1	4.1	0		73.3	10.7	16	0		14.4	70	15.6	0		
PHF	.594	.450	.757	.000	.777	.563	.926	.525	.000	.920	.655	.667	.750	.000	.721	.691	.939	.607	.000	.919	.908

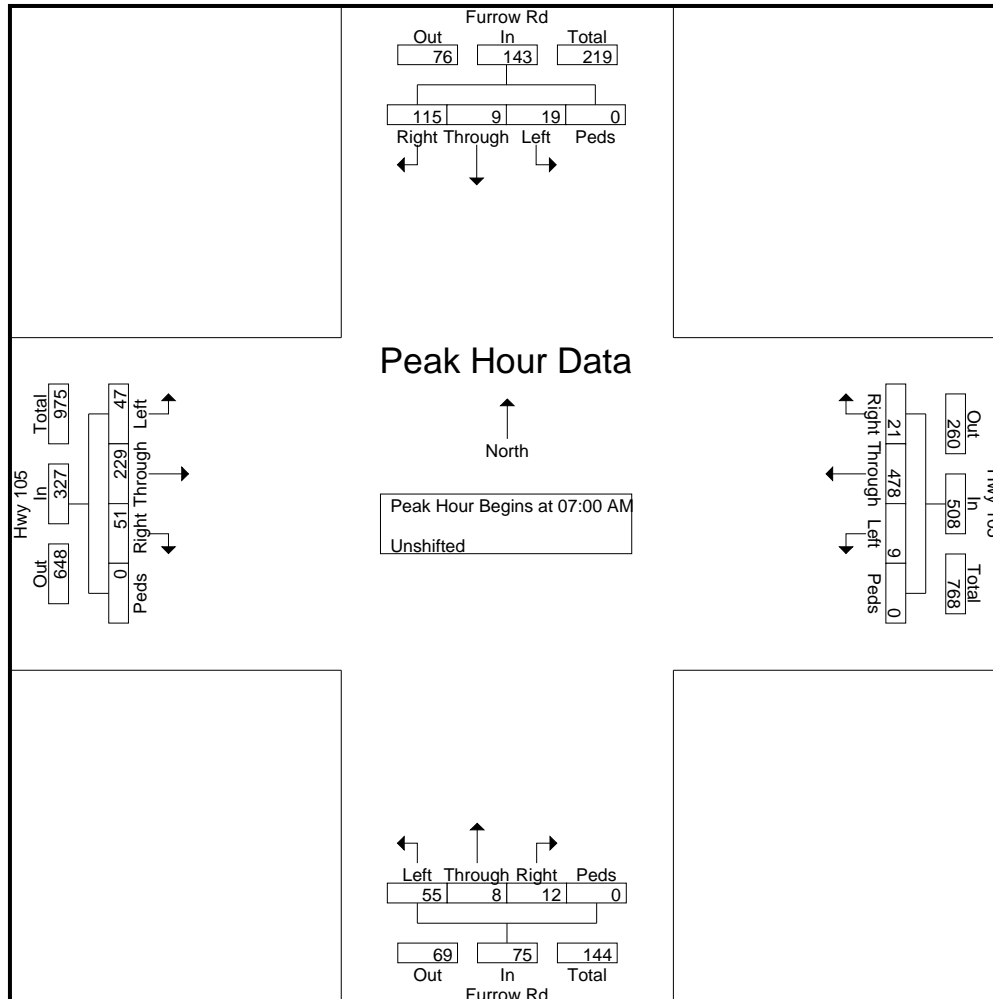





# LSC Transportation Consultants, Inc.

545 E Pikes Peak Ave, Suite 210  
 Colorado Springs, CO 80905  
 719-633-2868

File Name : Furrow Rd - Hwy 105 AM  
 Site Code : 185020  
 Start Date : 8/27/2019  
 Page No : 3

Start Time	Furrow Rd Southbound					Hwy 105 Westbound					Furrow Rd Northbound					Hwy 105 Eastbound					Int. Total
	Left	Through	Right	Peds	App. Total	Left	Through	Right	Peds	App. Total	Left	Through	Right	Peds	App. Total	Left	Through	Right	Peds	App. Total	
<b>Peak Hour Analysis From 06:30 AM to 08:15 AM - Peak 1 of 1</b>																					
Peak Hour for Each Approach Begins at:																					
	06:45 AM					07:00 AM					07:15 AM					07:15 AM					
+0 mins.	3	1	23	0	27	3	125	10	0	138	21	1	4	0	26	12	61	14	0	87	
+15 mins.	2	1	26	0	29	1	129	4	0	134	16	2	3	0	21	11	60	7	0	78	
+30 mins.	5	0	38	0	43	1	116	2	0	119	8	3	2	0	13	17	51	21	0	89	
+45 mins.	8	5	33	0	46	4	108	5	0	117	17	3	4	0	24	10	59	15	0	84	
Total Volume	18	7	120	0	145	9	478	21	0	508	62	9	13	0	84	50	231	57	0	338	
% App. Total	12.4	4.8	82.8	0		1.8	94.1	4.1	0		73.8	10.7	15.5	0		14.8	68.3	16.9	0		
PHF	.563	.350	.789	.000	.788	.563	.926	.525	.000	.920	.738	.750	.813	.000	.808	.735	.947	.679	.000	.949	

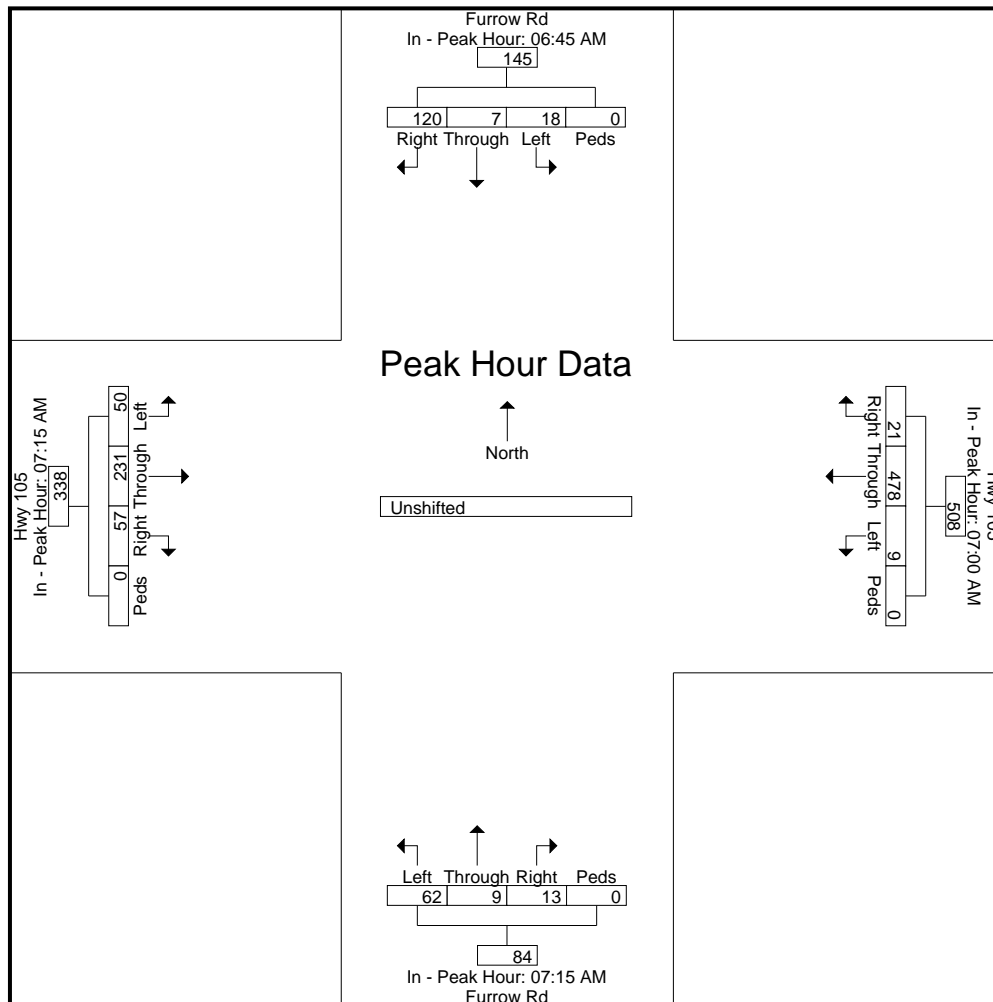



# LSC Transportation Consultants, Inc.

545 E Pikes Peak Ave, Suite 210

Colorado Springs, CO 80905

719-633-2868

File Name : Furrow Rd - Hwy 105 PM

Site Code : 185020

Start Date : 8/27/2019

Page No : 1

### Groups Printed- Unshifted

Start Time	Furrow Rd Southbound					Hwy 105 Westbound					Furrow Rd Northbound					Hwy 105 Eastbound					Int. Total
	Left	Through	Right	Peds	App. Total	Left	Through	Right	Peds	App. Total	Left	Through	Right	Peds	App. Total	Left	Through	Right	Peds	App. Total	
04:00 PM	7	2	21	0	30	6	92	3	0	101	9	2	2	0	13	30	99	9	0	138	282
04:15 PM	4	1	13	0	18	5	88	9	0	102	17	0	2	0	19	31	99	22	0	152	291
04:30 PM	5	1	22	0	28	3	77	6	0	86	14	2	8	0	24	22	88	17	0	127	265
04:45 PM	5	1	26	0	32	2	75	5	0	82	10	3	4	0	17	33	98	22	0	153	284
Total	21	5	82	0	108	16	332	23	0	371	50	7	16	0	73	116	384	70	0	570	1122
05:00 PM	8	4	24	0	36	4	97	7	0	108	17	5	2	0	24	30	105	17	0	152	320
05:15 PM	1	2	24	0	27	3	82	6	0	91	17	0	3	0	20	30	117	13	0	160	298
05:30 PM	4	2	28	0	34	2	82	8	0	92	10	1	1	0	12	31	101	8	0	140	278
05:45 PM	3	1	20	0	24	3	72	8	0	83	7	3	8	0	18	35	90	12	0	137	262
Total	16	9	96	0	121	12	333	29	0	374	51	9	14	0	74	126	413	50	0	589	1158
Grand Total	37	14	178	0	229	28	665	52	0	745	101	16	30	0	147	242	797	120	0	1159	2280
Apprch %	16.2	6.1	77.7	0		3.8	89.3	7	0		68.7	10.9	20.4	0		20.9	68.8	10.4	0		
Total %	1.6	0.6	7.8	0	10	1.2	29.2	2.3	0	32.7	4.4	0.7	1.3	0	6.4	10.6	35	5.3	0	50.8	



# LSC Transportation Consultants, Inc.

545 E Pikes Peak Ave, Suite 210  
 Colorado Springs, CO 80905  
 719-633-2868

File Name : Furrow Rd - Hwy 105 PM  
 Site Code : 185020  
 Start Date : 8/27/2019  
 Page No : 2

Start Time	Furrow Rd Southbound					Hwy 105 Westbound					Furrow Rd Northbound					Hwy 105 Eastbound					Int. Total
	Left	Through	Right	Peds	App. Total	Left	Through	Right	Peds	App. Total	Left	Through	Right	Peds	App. Total	Left	Through	Right	Peds	App. Total	
<b>Peak Hour Analysis From 04:00 PM to 05:45 PM - Peak 1 of 1</b>																					
Peak Hour for Entire Intersection Begins at 04:45 PM																					
04:45 PM	5	1	26	0	32	2	75	5	0	82	10	3	4	0	17	33	98	22	0	153	284
05:00 PM	8	4	24	0	36	4	97	7	0	108	17	5	2	0	24	30	105	17	0	152	320
05:15 PM	1	2	24	0	27	3	82	6	0	91	17	0	3	0	20	30	117	13	0	160	298
05:30 PM	4	2	28	0	34	2	82	8	0	92	10	1	1	0	12	31	101	8	0	140	278
Total Volume	18	9	102	0	129	11	336	26	0	373	54	9	10	0	73	124	421	60	0	605	1180
% App. Total	14	7	79.1	0		2.9	90.1	7	0		74	12.3	13.7	0		20.5	69.6	9.9	0		
PHF	.563	.563	.911	.000	.896	.688	.866	.813	.000	.863	.794	.450	.625	.000	.760	.939	.900	.682	.000	.945	.922

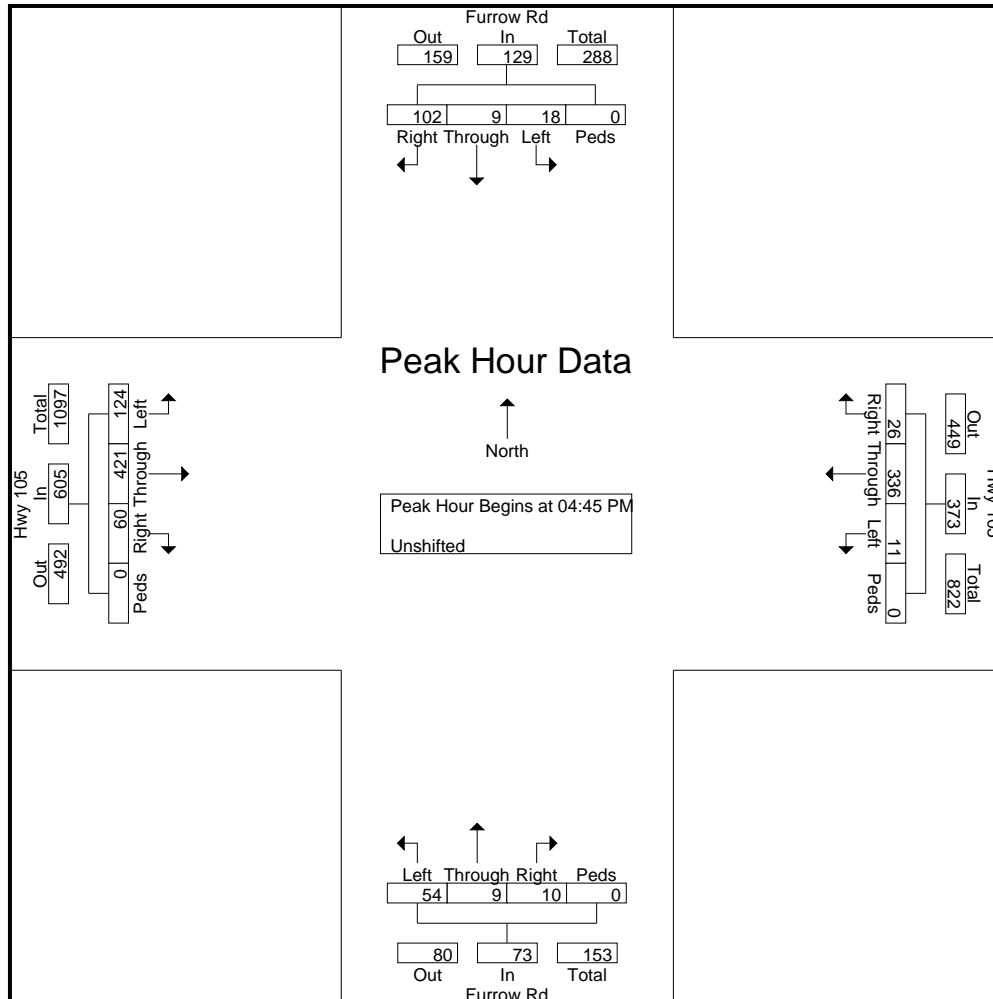



# LSC Transportation Consultants, Inc.

545 E Pikes Peak Ave, Suite 210

Colorado Springs, CO 80905

719-633-2868

File Name : Furrow Rd - Hwy 105 PM

Site Code : 185020

Start Date : 8/27/2019

Page No : 3

Start Time	Furrow Rd Southbound					Hwy 105 Westbound					Furrow Rd Northbound					Hwy 105 Eastbound					Int. Total
	Left	Through	Right	Peds	App. Total	Left	Through	Right	Peds	App. Total	Left	Through	Right	Peds	App. Total	Left	Through	Right	Peds	App. Total	
<b>Peak Hour Analysis From 04:00 PM to 05:45 PM - Peak 1 of 1</b>																					
Peak Hour for Each Approach Begins at:																					
	04:45 PM					04:15 PM					04:30 PM					04:45 PM					
+0 mins.	5	1	26	0	32	5	88	9	0	102	14	2	8	0	24	33	98	22	0	153	
+15 mins.	8	4	24	0	36	3	77	6	0	86	10	3	4	0	17	30	105	17	0	152	
+30 mins.	1	2	24	0	27	2	75	5	0	82	17	5	2	0	24	30	117	13	0	160	
+45 mins.	4	2	28	0	34	4	97	7	0	108	17	0	3	0	20	31	101	8	0	140	
Total Volume	18	9	102	0	129	14	337	27	0	378	58	10	17	0	85	124	421	60	0	605	
% App. Total	14	7	79.1	0		3.7	89.2	7.1	0		68.2	11.8	20	0		20.5	69.6	9.9	0		
PHF	.563	.563	.911	.000	.896	.700	.869	.750	.000	.875	.853	.500	.531	.000	.885	.939	.900	.682	.000	.945	

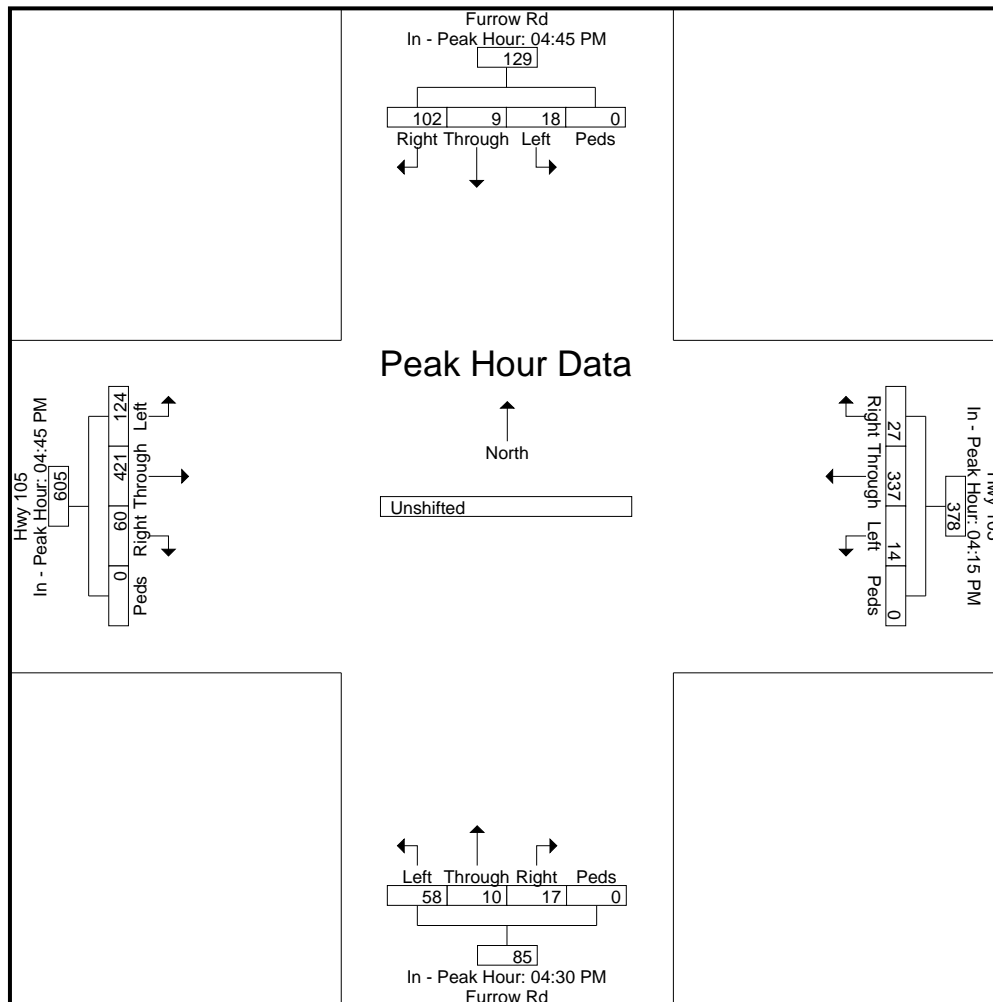

### FAIRPLAY DR HIGBY RD

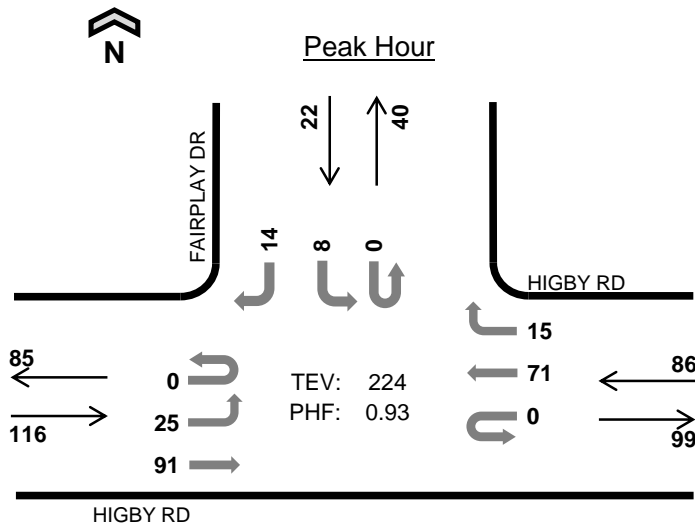

Date: Wed, May 16, 2018  
Count Period: 4:00 PM to 6:00 PM  
Peak Hour: 5:00 PM to 6:00 PM

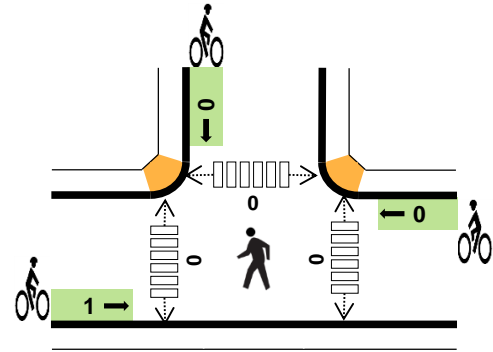

	HV %:	PHF
EB	0.0%	0.88
WB	1.2%	0.93
NB	-	-
SB	0.0%	0.69
TOTAL	0.4%	0.93

#### Two-Hour Count Summaries

Interval Start	HIGBY RD Eastbound				HIGBY RD Westbound				0 Northbound				FAIRPLAY DR Southbound				15-min Total	Rolling One Hour
	UT	LT	TH	RT	UT	LT	TH	RT	UT	LT	TH	RT	UT	LT	TH	RT		
4:00 PM	0	4	18	0	0	0	17	2	0	0	0	0	0	2	0	3	46	0
4:15 PM	0	5	24	0	0	0	12	3	0	0	0	0	0	3	0	1	48	0
4:30 PM	0	6	20	0	0	0	13	2	0	0	0	0	0	1	0	2	44	0
4:45 PM	0	3	21	0	0	0	19	1	0	0	0	0	0	1	0	2	47	185
<b>5:00 PM</b>	<b>0</b>	<b>7</b>	<b>21</b>	<b>0</b>	<b>0</b>	<b>0</b>	<b>14</b>	<b>7</b>	<b>0</b>	<b>0</b>	<b>0</b>	<b>0</b>	<b>0</b>	<b>2</b>	<b>0</b>	<b>6</b>	<b>57</b>	<b>196</b>
5:15 PM	0	5	22	0	0	0	21	2	0	0	0	0	0	1	0	4	55	203
<b>5:30 PM</b>	<b>0</b>	<b>9</b>	<b>24</b>	<b>0</b>	<b>0</b>	<b>0</b>	<b>19</b>	<b>3</b>	<b>0</b>	<b>0</b>	<b>0</b>	<b>0</b>	<b>0</b>	<b>3</b>	<b>0</b>	<b>2</b>	<b>60</b>	<b>219</b>
5:45 PM	0	4	24	0	0	0	17	3	0	0	0	0	0	2	0	2	52	224
Count Total	0	43	174	0	0	0	132	23	0	0	0	0	0	15	0	22	409	0
<b>Peak Hour</b>	<b>0</b>	<b>25</b>	<b>91</b>	<b>0</b>	<b>0</b>	<b>0</b>	<b>71</b>	<b>15</b>	<b>0</b>	<b>0</b>	<b>0</b>	<b>0</b>	<b>0</b>	<b>8</b>	<b>0</b>	<b>14</b>	<b>224</b>	<b>0</b>

Note: Two-hour count summary volumes include heavy vehicles but exclude bicycles in overall count.

Interval Start	Heavy Vehicle Totals					Bicycles					Pedestrians (Crossing Leg)				
	EB	WB	NB	SB	Total	EB	WB	NB	SB	Total	East	West	North	South	Total
4:00 PM	0	0	0	0	0	0	0	0	0	0	0	0	0	0	0
4:15 PM	2	1	0	0	3	0	0	0	0	0	0	0	0	0	0
4:30 PM	0	1	0	0	1	0	0	0	0	0	0	0	0	0	0
4:45 PM	0	0	0	0	0	0	0	0	0	0	0	0	0	0	0
<b>5:00 PM</b>	<b>0</b>	<b>0</b>	<b>0</b>	<b>0</b>	<b>0</b>	<b>0</b>	<b>0</b>	<b>0</b>	<b>0</b>	<b>0</b>	<b>0</b>	<b>0</b>	<b>0</b>	<b>0</b>	<b>0</b>
5:15 PM	0	0	0	0	0	0	0	0	0	0	0	0	0	0	0
<b>5:30 PM</b>	<b>0</b>	<b>0</b>	<b>0</b>	<b>0</b>	<b>0</b>	<b>1</b>	<b>0</b>	<b>0</b>	<b>0</b>	<b>1</b>	<b>0</b>	<b>0</b>	<b>0</b>	<b>0</b>	<b>0</b>
5:45 PM	0	1	0	0	1	0	0	0	0	0	0	0	0	0	0
Count Total	2	3	0	0	5	1	0	0	0	1	0	0	0	0	0
<b>Peak Hr</b>	<b>0</b>	<b>1</b>	<b>0</b>	<b>0</b>	<b>1</b>	<b>1</b>	<b>0</b>	<b>0</b>	<b>0</b>	<b>1</b>	<b>0</b>	<b>0</b>	<b>0</b>	<b>0</b>	<b>0</b>



Intersection						
Int Delay, s/veh	1.3					
Movement	EBL	EBT	WBT	WBR	SBL	SBR
Lane Configurations		↶	↷		↶	↷
Traffic Vol, veh/h	4	33	94	10	12	16
Future Vol, veh/h	4	33	94	10	12	16
Conflicting Peds, #/hr	0	0	0	0	0	0
Sign Control	Free	Free	Free	Free	Stop	Stop
RT Channelized	-	None	-	None	-	None
Storage Length	-	-	-	-	0	-
Veh in Median Storage, #	-	0	0	-	0	-
Grade, %	-	6	0	-	0	-
Peak Hour Factor	93	93	60	60	92	92
Heavy Vehicles, %	2	2	2	2	2	2
Mvmt Flow	4	35	157	17	13	17

Major/Minor	Major1	Major2	Minor2		
Conflicting Flow All	174	0	-	0	209 166
Stage 1	-	-	-	-	166 -
Stage 2	-	-	-	-	43 -
Critical Hdwy	4.12	-	-	-	6.42 6.22
Critical Hdwy Stg 1	-	-	-	-	5.42 -
Critical Hdwy Stg 2	-	-	-	-	5.42 -
Follow-up Hdwy	2.218	-	-	-	3.518 3.318
Pot Cap-1 Maneuver	1403	-	-	-	779 878
Stage 1	-	-	-	-	863 -
Stage 2	-	-	-	-	979 -
Platoon blocked, %		-	-	-	
Mov Cap-1 Maneuver	1403	-	-	-	777 878
Mov Cap-2 Maneuver	-	-	-	-	777 -
Stage 1	-	-	-	-	860 -
Stage 2	-	-	-	-	979 -

Approach	EB	WB	SB
HCM Control Delay, s	0.8	0	9.5
HCM LOS			A

Minor Lane/Major Mvmt	EBL	EBT	WBT	WBR	SBLn1
Capacity (veh/h)	1403	-	-	-	832
HCM Lane V/C Ratio	0.003	-	-	-	0.037
HCM Control Delay (s)	7.6	0	-	-	9.5
HCM Lane LOS	A	A	-	-	A
HCM 95th %tile Q(veh)	0	-	-	-	0.1

Intersection												
Int Delay, s/veh	6.7											
Movement	EBL	EBT	EBR	WBL	WBT	WBR	NBL	NBT	NBR	SBL	SBT	SBR
Lane Configurations												
Traffic Vol, veh/h	50	230	51	9	478	21	55	8	12	19	9	115
Future Vol, veh/h	50	230	51	9	478	21	55	8	12	19	9	115
Conflicting Peds, #/hr	0	0	0	0	0	0	0	0	0	0	0	0
Sign Control	Free	Free	Free	Free	Free	Free	Stop	Stop	Stop	Stop	Stop	Stop
RT Channelized	-	-	None	-	-	None	-	-	None	-	-	None
Storage Length	310	-	420	330	-	-	-	-	140	-	-	-
Veh in Median Storage, #	-	0	-	-	0	-	-	0	-	-	0	-
Grade, %	-	0	-	-	0	-	-	0	-	-	0	-
Peak Hour Factor	94	94	94	95	95	95	72	72	72	83	83	83
Heavy Vehicles, %	2	2	2	2	2	2	2	2	2	2	2	2
Mvmt Flow	53	245	54	9	503	22	76	11	17	23	11	139

Major/Minor	Major1			Major2			Minor1			Minor2		
Conflicting Flow All	525	0	0	299	0	0	958	894	245	924	937	514
Stage 1	-	-	-	-	-	-	351	351	-	532	532	-
Stage 2	-	-	-	-	-	-	607	543	-	392	405	-
Critical Hdwy	4.12	-	-	4.12	-	-	7.12	6.52	6.22	7.12	6.52	6.22
Critical Hdwy Stg 1	-	-	-	-	-	-	6.12	5.52	-	6.12	5.52	-
Critical Hdwy Stg 2	-	-	-	-	-	-	6.12	5.52	-	6.12	5.52	-
Follow-up Hdwy	2.218	-	-	2.218	-	-	3.518	4.018	3.318	3.518	4.018	3.318
Pot Cap-1 Maneuver	1042	-	-	1262	-	-	237	280	794	250	265	560
Stage 1	-	-	-	-	-	-	666	632	-	531	526	-
Stage 2	-	-	-	-	-	-	483	520	-	633	598	-
Platoon blocked, %	-	-	-	-	-	-	-	-	-	-	-	-
Mov Cap-1 Maneuver	1042	-	-	1262	-	-	165	264	794	227	250	560
Mov Cap-2 Maneuver	-	-	-	-	-	-	165	264	-	227	250	-
Stage 1	-	-	-	-	-	-	632	600	-	504	522	-
Stage 2	-	-	-	-	-	-	353	516	-	577	568	-

Approach	EB			WB			NB			SB		
HCM Control Delay, s	1.3			0.1			39.7			18.4		
HCM LOS							E			C		

Minor Lane/Major Mvmt	NBLn1	NBLn2	EBL	EBT	EBR	WBL	WBT	WBR	SBLn1
Capacity (veh/h)	173	794	1042	-	-	1262	-	-	440
HCM Lane V/C Ratio	0.506	0.021	0.051	-	-	0.008	-	-	0.392
HCM Control Delay (s)	45.4	9.6	8.6	-	-	7.9	-	-	18.4
HCM Lane LOS	E	A	A	-	-	A	-	-	C
HCM 95th %tile Q(veh)	2.5	0.1	0.2	-	-	0	-	-	1.8



Intersection						
Int Delay, s/veh	2.2					
Movement	EBL	EBT	WBT	WBR	SBL	SBR
Lane Configurations		↶	↷		↶	↷
Traffic Vol, veh/h	25	81	71	15	18	14
Future Vol, veh/h	25	81	71	15	18	14
Conflicting Peds, #/hr	0	0	0	0	0	0
Sign Control	Free	Free	Free	Free	Stop	Stop
RT Channelized	-	None	-	None	-	None
Storage Length	-	-	-	-	0	-
Veh in Median Storage, #	-	0	0	-	0	-
Grade, %	-	6	0	-	0	-
Peak Hour Factor	88	88	98	98	100	100
Heavy Vehicles, %	2	2	2	2	2	2
Mvmt Flow	28	92	72	15	18	14

Major/Minor	Major1	Major2	Minor2		
Conflicting Flow All	87	0	-	0	228 80
Stage 1	-	-	-	-	80 -
Stage 2	-	-	-	-	148 -
Critical Hdwy	4.12	-	-	-	6.42 6.22
Critical Hdwy Stg 1	-	-	-	-	5.42 -
Critical Hdwy Stg 2	-	-	-	-	5.42 -
Follow-up Hdwy	2.218	-	-	-	3.518 3.318
Pot Cap-1 Maneuver	1509	-	-	-	760 980
Stage 1	-	-	-	-	943 -
Stage 2	-	-	-	-	880 -
Platoon blocked, %		-	-	-	
Mov Cap-1 Maneuver	1509	-	-	-	745 980
Mov Cap-2 Maneuver	-	-	-	-	745 -
Stage 1	-	-	-	-	924 -
Stage 2	-	-	-	-	880 -

Approach	EB	WB	SB
HCM Control Delay, s	1.8	0	9.5
HCM LOS			A

Minor Lane/Major Mvmt	EBL	EBT	WBT	WBR	SBLn1
Capacity (veh/h)	1509	-	-	-	832
HCM Lane V/C Ratio	0.019	-	-	-	0.038
HCM Control Delay (s)	7.4	0	-	-	9.5
HCM Lane LOS	A	A	-	-	A
HCM 95th %tile Q(veh)	0.1	-	-	-	0.1

Intersection												
Int Delay, s/veh	8											
Movement	EBL	EBT	EBR	WBL	WBT	WBR	NBL	NBT	NBR	SBL	SBT	SBR
Lane Configurations	↖	↑	↗	↖	↑	↗		↖	↗		↕	
Traffic Vol, veh/h	124	421	60	11	336	26	54	9	10	18	9	102
Future Vol, veh/h	124	421	60	11	336	26	54	9	10	18	9	102
Conflicting Peds, #/hr	0	0	0	0	0	0	0	0	0	0	0	0
Sign Control	Free	Free	Free	Free	Free	Free	Stop	Stop	Stop	Stop	Stop	Stop
RT Channelized	-	-	None	-	-	None	-	-	None	-	-	None
Storage Length	310	-	420	330	-	-	-	-	140	-	-	-
Veh in Median Storage, #	-	0	-	-	0	-	-	0	-	-	0	-
Grade, %	-	0	-	-	0	-	-	0	-	-	0	-
Peak Hour Factor	100	100	100	86	86	86	76	76	76	90	90	90
Heavy Vehicles, %	2	2	2	2	2	2	2	2	2	2	2	2
Mvmt Flow	124	421	60	13	391	30	71	12	13	20	10	113

Major/Minor	Major1			Major2			Minor1			Minor2		
Conflicting Flow All	421	0	0	481	0	0	1163	1116	421	1144	1161	406
Stage 1	-	-	-	-	-	-	669	669	-	432	432	-
Stage 2	-	-	-	-	-	-	494	447	-	712	729	-
Critical Hdwy	4.12	-	-	4.12	-	-	7.12	6.52	6.22	7.12	6.52	6.22
Critical Hdwy Stg 1	-	-	-	-	-	-	6.12	5.52	-	6.12	5.52	-
Critical Hdwy Stg 2	-	-	-	-	-	-	6.12	5.52	-	6.12	5.52	-
Follow-up Hdwy	2.218	-	-	2.218	-	-	3.518	4.018	3.318	3.518	4.018	3.318
Pot Cap-1 Maneuver	1138	-	-	1082	-	-	172	208	632	177	195	645
Stage 1	-	-	-	-	-	-	447	456	-	602	582	-
Stage 2	-	-	-	-	-	-	557	573	-	423	428	-
Platoon blocked, %	-	-	-	-	-	-	-	-	-	-	-	-
Mov Cap-1 Maneuver	1138	-	-	1082	-	-	123	183	632	150	172	645
Mov Cap-2 Maneuver	-	-	-	-	-	-	123	183	-	150	172	-
Stage 1	-	-	-	-	-	-	398	406	-	536	575	-
Stage 2	-	-	-	-	-	-	446	566	-	358	381	-

Approach	EB			WB			NB			SB		
HCM Control Delay, s	1.8			0.2			64.6			19.5		
HCM LOS							F			C		

Minor Lane/Major Mvmt	NBLn1	NBLn2	EBL	EBT	EBR	WBL	WBT	WBR	SBLn1
Capacity (veh/h)	129	632	1138	-	-	1082	-	-	390
HCM Lane V/C Ratio	0.643	0.021	0.109	-	-	0.012	-	-	0.368
HCM Control Delay (s)	73.1	10.8	8.6	-	-	8.4	-	-	19.5
HCM Lane LOS	F	B	A	-	-	A	-	-	C
HCM 95th %tile Q(veh)	3.4	0.1	0.4	-	-	0	-	-	1.7

Intersection						
Int Delay, s/veh	2.1					
Movement	EBL	EBT	WBT	WBR	SBL	SBR
Lane Configurations	↘	↑	↗		↘	
Traffic Vol, veh/h	25	50	105	15	15	30
Future Vol, veh/h	25	50	105	15	15	30
Conflicting Peds, #/hr	0	0	0	0	0	0
Sign Control	Free	Free	Free	Free	Stop	Stop
RT Channelized	-	None	-	None	-	None
Storage Length	135	-	-	-	0	-
Veh in Median Storage, #	-	0	0	-	0	-
Grade, %	-	6	6	-	0	-
Peak Hour Factor	93	93	60	60	92	92
Heavy Vehicles, %	2	2	2	2	2	2
Mvmt Flow	27	54	175	25	16	33

Major/Minor	Major1	Major2	Minor2		
Conflicting Flow All	200	0	-	0	296 188
Stage 1	-	-	-	-	188 -
Stage 2	-	-	-	-	108 -
Critical Hdwy	4.12	-	-	-	6.42 6.22
Critical Hdwy Stg 1	-	-	-	-	5.42 -
Critical Hdwy Stg 2	-	-	-	-	5.42 -
Follow-up Hdwy	2.218	-	-	-	3.518 3.318
Pot Cap-1 Maneuver	1372	-	-	-	695 854
Stage 1	-	-	-	-	844 -
Stage 2	-	-	-	-	916 -
Platoon blocked, %		-	-	-	
Mov Cap-1 Maneuver	1372	-	-	-	681 854
Mov Cap-2 Maneuver	-	-	-	-	681 -
Stage 1	-	-	-	-	827 -
Stage 2	-	-	-	-	916 -

Approach	EB	WB	SB
HCM Control Delay, s	2.6	0	9.9
HCM LOS			A

Minor Lane/Major Mvmt	EBL	EBT	WBT	WBR	SBLn1
Capacity (veh/h)	1372	-	-	-	787
HCM Lane V/C Ratio	0.02	-	-	-	0.062
HCM Control Delay (s)	7.7	-	-	-	9.9
HCM Lane LOS	A	-	-	-	A
HCM 95th %tile Q(veh)	0.1	-	-	-	0.2

**Intersection**

Int Delay, s/veh 1.1

Movement	EBL	EBT	WBT	WBR	SBL	SBR
Lane Configurations		↕	↕		↕	
Traffic Vol, veh/h	5	60	125	10	15	15
Future Vol, veh/h	5	60	125	10	15	15
Conflicting Peds, #/hr	0	0	0	0	0	0
Sign Control	Free	Free	Free	Free	Stop	Stop
RT Channelized	-	None	-	None	-	None
Storage Length	-	-	-	-	0	-
Veh in Median Storage, #	-	0	0	-	0	-
Grade, %	-	6	0	-	0	-
Peak Hour Factor	93	93	60	60	92	92
Heavy Vehicles, %	2	2	2	2	2	2
Mvmt Flow	5	65	208	17	16	16

Major/Minor	Major1	Major2	Minor2		
Conflicting Flow All	225	0	-	0	292
Stage 1	-	-	-	-	217
Stage 2	-	-	-	-	75
Critical Hdwy	4.12	-	-	-	6.42
Critical Hdwy Stg 1	-	-	-	-	5.42
Critical Hdwy Stg 2	-	-	-	-	5.42
Follow-up Hdwy	2.218	-	-	-	3.518
Pot Cap-1 Maneuver	1344	-	-	-	699
Stage 1	-	-	-	-	819
Stage 2	-	-	-	-	948
Platoon blocked, %		-	-	-	
Mov Cap-1 Maneuver	1344	-	-	-	696
Mov Cap-2 Maneuver	-	-	-	-	696
Stage 1	-	-	-	-	816
Stage 2	-	-	-	-	948

Approach	EB	WB	SB
HCM Control Delay, s	0.6	0	10
HCM LOS			B

Minor Lane/Major Mvmt	EBL	EBT	WBT	WBR	SBLn1
Capacity (veh/h)	1344	-	-	-	754
HCM Lane V/C Ratio	0.004	-	-	-	0.043
HCM Control Delay (s)	7.7	0	-	-	10
HCM Lane LOS	A	A	-	-	B
HCM 95th %tile Q(veh)	0	-	-	-	0.1

Intersection												
Int Delay, s/veh	8.7											
Movement	EBL	EBT	EBR	WBL	WBT	WBR	NBL	NBT	NBR	SBL	SBT	SBR
Lane Configurations												
Traffic Vol, veh/h	50	230	45	20	490	25	50	15	15	20	25	120
Future Vol, veh/h	50	230	45	20	490	25	50	15	15	20	25	120
Conflicting Peds, #/hr	0	0	0	0	0	0	0	0	0	0	0	0
Sign Control	Free	Free	Free	Free	Free	Free	Stop	Stop	Stop	Stop	Stop	Stop
RT Channelized	-	-	None	-	-	None	-	-	None	-	-	None
Storage Length	310	-	420	330	-	-	-	-	140	-	-	-
Veh in Median Storage, #	-	0	-	-	0	-	-	0	-	-	0	-
Grade, %	-	0	-	-	0	-	-	0	-	-	0	-
Peak Hour Factor	94	94	94	95	95	95	72	72	72	83	83	83
Heavy Vehicles, %	2	2	2	2	2	2	2	2	2	2	2	2
Mvmt Flow	53	245	48	21	516	26	69	21	21	24	30	145

Major/Minor	Major1			Major2			Minor1			Minor2		
Conflicting Flow All	542	0	0	293	0	0	1010	935	245	967	970	529
Stage 1	-	-	-	-	-	-	351	351	-	571	571	-
Stage 2	-	-	-	-	-	-	659	584	-	396	399	-
Critical Hdwy	4.12	-	-	4.12	-	-	7.12	6.52	6.22	7.12	6.52	6.22
Critical Hdwy Stg 1	-	-	-	-	-	-	6.12	5.52	-	6.12	5.52	-
Critical Hdwy Stg 2	-	-	-	-	-	-	6.12	5.52	-	6.12	5.52	-
Follow-up Hdwy	2.218	-	-	2.218	-	-	3.518	4.018	3.318	3.518	4.018	3.318
Pot Cap-1 Maneuver	1027	-	-	1269	-	-	218	265	794	234	253	550
Stage 1	-	-	-	-	-	-	666	632	-	506	505	-
Stage 2	-	-	-	-	-	-	453	498	-	629	602	-
Platoon blocked, %	-	-	-	-	-	-	-	-	-	-	-	-
Mov Cap-1 Maneuver	1027	-	-	1269	-	-	138	247	794	202	236	550
Mov Cap-2 Maneuver	-	-	-	-	-	-	138	247	-	202	236	-
Stage 1	-	-	-	-	-	-	631	599	-	480	496	-
Stage 2	-	-	-	-	-	-	308	490	-	561	571	-

Approach	EB			WB			NB			SB		
HCM Control Delay, s	1.3			0.3			48.2			23.4		
HCM LOS							E			C		

Minor Lane/Major Mvmt	NBLn1	NBLn2	EBL	EBT	EBR	WBL	WBT	WBR	SBLn1
Capacity (veh/h)	154	794	1027	-	-	1269	-	-	390
HCM Lane V/C Ratio	0.586	0.026	0.052	-	-	0.017	-	-	0.51
HCM Control Delay (s)	57.1	9.7	8.7	-	-	7.9	-	-	23.4
HCM Lane LOS	F	A	A	-	-	A	-	-	C
HCM 95th %tile Q(veh)	3.1	0.1	0.2	-	-	0.1	-	-	2.8

Intersection						
Int Delay, s/veh	2.6					
Movement	EBL	EBT	WBT	WBR	SBL	SBR
Lane Configurations						
Traffic Vol, veh/h	25	50	105	15	15	30
Future Vol, veh/h	25	50	105	15	15	30
Conflicting Peds, #/hr	0	0	0	0	0	0
Sign Control	Free	Free	Free	Free	Stop	Stop
RT Channelized	-	None	-	None	-	None
Storage Length	140	-	-	-	0	-
Veh in Median Storage, #	-	0	0	-	0	-
Grade, %	-	6	6	-	0	-
Peak Hour Factor	88	88	98	98	92	92
Heavy Vehicles, %	2	2	2	2	2	2
Mvmt Flow	28	57	107	15	16	33

Major/Minor	Major1	Major2	Minor2		
Conflicting Flow All	122	0	-	0	228 115
Stage 1	-	-	-	-	115 -
Stage 2	-	-	-	-	113 -
Critical Hdwy	4.12	-	-	-	6.42 6.22
Critical Hdwy Stg 1	-	-	-	-	5.42 -
Critical Hdwy Stg 2	-	-	-	-	5.42 -
Follow-up Hdwy	2.218	-	-	-	3.518 3.318
Pot Cap-1 Maneuver	1465	-	-	-	760 937
Stage 1	-	-	-	-	910 -
Stage 2	-	-	-	-	912 -
Platoon blocked, %		-	-	-	
Mov Cap-1 Maneuver	1465	-	-	-	746 937
Mov Cap-2 Maneuver	-	-	-	-	746 -
Stage 1	-	-	-	-	893 -
Stage 2	-	-	-	-	912 -

Approach	EB	WB	SB
HCM Control Delay, s	2.5	0	9.4
HCM LOS			A

Minor Lane/Major Mvmt	EBL	EBT	WBT	WBR	SBLn1
Capacity (veh/h)	1465	-	-	-	863
HCM Lane V/C Ratio	0.019	-	-	-	0.057
HCM Control Delay (s)	7.5	-	-	-	9.4
HCM Lane LOS	A	-	-	-	A
HCM 95th %tile Q(veh)	0.1	-	-	-	0.2

Intersection						
Int Delay, s/veh	1.4					
Movement	EBL	EBT	WBT	WBR	SBL	SBR
Lane Configurations		↶	↷		↶	↷
Traffic Vol, veh/h	5	60	125	10	15	15
Future Vol, veh/h	5	60	125	10	15	15
Conflicting Peds, #/hr	0	0	0	0	0	0
Sign Control	Free	Free	Free	Free	Stop	Stop
RT Channelized	-	None	-	None	-	None
Storage Length	-	-	-	-	0	-
Veh in Median Storage, #	-	0	0	-	0	-
Grade, %	-	6	0	-	0	-
Peak Hour Factor	88	88	98	98	100	100
Heavy Vehicles, %	2	2	2	2	2	2
Mvmt Flow	6	68	128	10	15	15

Major/Minor	Major1	Major2	Minor2		
Conflicting Flow All	138	0	-	0	213
Stage 1	-	-	-	-	133
Stage 2	-	-	-	-	80
Critical Hdwy	4.12	-	-	-	6.42
Critical Hdwy Stg 1	-	-	-	-	5.42
Critical Hdwy Stg 2	-	-	-	-	5.42
Follow-up Hdwy	2.218	-	-	-	3.518
Pot Cap-1 Maneuver	1446	-	-	-	775
Stage 1	-	-	-	-	893
Stage 2	-	-	-	-	943
Platoon blocked, %		-	-	-	
Mov Cap-1 Maneuver	1446	-	-	-	772
Mov Cap-2 Maneuver	-	-	-	-	772
Stage 1	-	-	-	-	889
Stage 2	-	-	-	-	943

Approach	EB	WB	SB
HCM Control Delay, s	0.6	0	9.5
HCM LOS			A

Minor Lane/Major Mvmt	EBL	EBT	WBT	WBR	SBLn1
Capacity (veh/h)	1446	-	-	-	838
HCM Lane V/C Ratio	0.004	-	-	-	0.036
HCM Control Delay (s)	7.5	0	-	-	9.5
HCM Lane LOS	A	A	-	-	A
HCM 95th %tile Q(veh)	0	-	-	-	0.1

Intersection												
Int Delay, s/veh	9.5											
Movement	EBL	EBT	EBR	WBL	WBT	WBR	NBL	NBT	NBR	SBL	SBT	SBR
Lane Configurations	↙	↑	↗	↙	↑	↗		↙	↗		↕	
Traffic Vol, veh/h	130	425	50	25	340	30	40	15	20	20	25	105
Future Vol, veh/h	130	425	50	25	340	30	40	15	20	20	25	105
Conflicting Peds, #/hr	0	0	0	0	0	0	0	0	0	0	0	0
Sign Control	Free	Free	Free	Free	Free	Free	Stop	Stop	Stop	Stop	Stop	Stop
RT Channelized	-	-	None	-	-	None	-	-	None	-	-	None
Storage Length	310	-	420	330	-	-	-	-	140	-	-	-
Veh in Median Storage, #	-	0	-	-	0	-	-	0	-	-	0	-
Grade, %	-	0	-	-	0	-	-	0	-	-	0	-
Peak Hour Factor	100	100	100	86	86	86	76	76	76	90	90	90
Heavy Vehicles, %	2	2	2	2	2	2	2	2	2	2	2	2
Mvmt Flow	130	425	50	29	395	35	53	20	26	22	28	117

Major/Minor	Major1			Major2			Minor1			Minor2		
Conflicting Flow All	430	0	0	475	0	0	1228	1173	425	1204	1206	413
Stage 1	-	-	-	-	-	-	685	685	-	471	471	-
Stage 2	-	-	-	-	-	-	543	488	-	733	735	-
Critical Hdwy	4.12	-	-	4.12	-	-	7.12	6.52	6.22	7.12	6.52	6.22
Critical Hdwy Stg 1	-	-	-	-	-	-	6.12	5.52	-	6.12	5.52	-
Critical Hdwy Stg 2	-	-	-	-	-	-	6.12	5.52	-	6.12	5.52	-
Follow-up Hdwy	2.218	-	-	2.218	-	-	3.518	4.018	3.318	3.518	4.018	3.318
Pot Cap-1 Maneuver	1129	-	-	1087	-	-	155	192	629	161	184	639
Stage 1	-	-	-	-	-	-	438	448	-	573	560	-
Stage 2	-	-	-	-	-	-	524	550	-	412	425	-
Platoon blocked, %	-	-	-	-	-	-	-	-	-	-	-	-
Mov Cap-1 Maneuver	1129	-	-	1087	-	-	98	165	629	126	158	639
Mov Cap-2 Maneuver	-	-	-	-	-	-	98	165	-	126	158	-
Stage 1	-	-	-	-	-	-	388	396	-	507	545	-
Stage 2	-	-	-	-	-	-	396	535	-	332	376	-

Approach	EB			WB			NB			SB		
HCM Control Delay, s	1.8			0.5			65.8			29		
HCM LOS							F			D		

Minor Lane/Major Mvmt	NBLn1	NBLn2	EBL	EBT	EBR	WBL	WBT	WBR	SBLn1
Capacity (veh/h)	110	629	1129	-	-	1087	-	-	312
HCM Lane V/C Ratio	0.658	0.042	0.115	-	-	0.027	-	-	0.534
HCM Control Delay (s)	85.7	11	8.6	-	-	8.4	-	-	29
HCM Lane LOS	F	B	A	-	-	A	-	-	D
HCM 95th %tile Q(veh)	3.4	0.1	0.4	-	-	0.1	-	-	3



Intersection												
Int Delay, s/veh	1.4											
Movement	EBL	EBT	EBR	WBL	WBT	WBR	NBL	NBT	NBR	SBL	SBT	SBR
Lane Configurations		↕			↕			↕			↕	
Traffic Vol, veh/h	2	0	6	6	0	2	1	41	2	1	47	1
Future Vol, veh/h	2	0	6	6	0	2	1	41	2	1	47	1
Conflicting Peds, #/hr	0	0	0	0	0	0	0	0	0	0	0	0
Sign Control	Stop	Stop	Stop	Stop	Stop	Stop	Free	Free	Free	Free	Free	Free
RT Channelized	-	-	None	-	-	None	-	-	None	-	-	None
Storage Length	-	-	-	-	-	-	-	-	-	-	-	-
Veh in Median Storage, #	-	0	-	-	0	-	-	0	-	-	0	-
Grade, %	-	0	-	-	0	-	-	0	-	-	0	-
Peak Hour Factor	92	92	92	92	92	92	92	92	92	92	92	92
Heavy Vehicles, %	2	2	2	2	2	2	2	2	2	2	2	2
Mvmt Flow	2	0	7	7	0	2	1	45	2	1	51	1

Major/Minor	Minor2		Minor1		Major1			Major2				
Conflicting Flow All	103	103	52	105	102	46	52	0	0	47	0	0
Stage 1	54	54	-	48	48	-	-	-	-	-	-	-
Stage 2	49	49	-	57	54	-	-	-	-	-	-	-
Critical Hdwy	7.12	6.52	6.22	7.12	6.52	6.22	4.12	-	-	4.12	-	-
Critical Hdwy Stg 1	6.12	5.52	-	6.12	5.52	-	-	-	-	-	-	-
Critical Hdwy Stg 2	6.12	5.52	-	6.12	5.52	-	-	-	-	-	-	-
Follow-up Hdwy	3.518	4.018	3.318	3.518	4.018	3.318	2.218	-	-	2.218	-	-
Pot Cap-1 Maneuver	877	787	1016	875	788	1023	1554	-	-	1560	-	-
Stage 1	958	850	-	965	855	-	-	-	-	-	-	-
Stage 2	964	854	-	955	850	-	-	-	-	-	-	-
Platoon blocked, %								-	-	-	-	-
Mov Cap-1 Maneuver	873	785	1016	868	786	1023	1554	-	-	1560	-	-
Mov Cap-2 Maneuver	873	785	-	868	786	-	-	-	-	-	-	-
Stage 1	957	849	-	964	854	-	-	-	-	-	-	-
Stage 2	961	853	-	948	849	-	-	-	-	-	-	-

Approach	EB		WB		NB		SB	
HCM Control Delay, s	8.7		9		0.2		0.1	
HCM LOS	A		A					

Minor Lane/Major Mvmt	NBL	NBT	NBR	EBLn1	WBLn1	SBL	SBT	SBR
Capacity (veh/h)	1554	-	-	976	902	1560	-	-
HCM Lane V/C Ratio	0.001	-	-	0.009	0.01	0.001	-	-
HCM Control Delay (s)	7.3	0	-	8.7	9	7.3	0	-
HCM Lane LOS	A	A	-	A	A	A	A	-
HCM 95th %tile Q(veh)	0	-	-	0	0	0	-	-

Intersection						
Int Delay, s/veh	0.5					
Movement	EBL	EBT	WBT	WBR	SBL	SBR
Lane Configurations		↶	↷		↶	↷
Traffic Vol, veh/h	2	66	121	1	1	11
Future Vol, veh/h	2	66	121	1	1	11
Conflicting Peds, #/hr	0	0	0	0	0	0
Sign Control	Free	Free	Free	Free	Stop	Stop
RT Channelized	-	None	-	None	-	None
Storage Length	-	-	-	-	0	-
Veh in Median Storage, #	-	0	0	-	0	-
Grade, %	-	0	0	-	0	-
Peak Hour Factor	93	93	60	60	92	92
Heavy Vehicles, %	2	2	2	2	2	2
Mvmt Flow	2	71	202	2	1	12

Major/Minor	Major1	Major2	Minor2		
Conflicting Flow All	204	0	-	0	278 203
Stage 1	-	-	-	-	203 -
Stage 2	-	-	-	-	75 -
Critical Hdwy	4.12	-	-	-	6.42 6.22
Critical Hdwy Stg 1	-	-	-	-	5.42 -
Critical Hdwy Stg 2	-	-	-	-	5.42 -
Follow-up Hdwy	2.218	-	-	-	3.518 3.318
Pot Cap-1 Maneuver	1368	-	-	-	712 838
Stage 1	-	-	-	-	831 -
Stage 2	-	-	-	-	948 -
Platoon blocked, %		-	-	-	
Mov Cap-1 Maneuver	1368	-	-	-	711 838
Mov Cap-2 Maneuver	-	-	-	-	711 -
Stage 1	-	-	-	-	829 -
Stage 2	-	-	-	-	948 -

Approach	EB	WB	SB
HCM Control Delay, s	0.2	0	9.4
HCM LOS			A

Minor Lane/Major Mvmt	EBL	EBT	WBT	WBR	SBLn1
Capacity (veh/h)	1368	-	-	-	826
HCM Lane V/C Ratio	0.002	-	-	-	0.016
HCM Control Delay (s)	7.6	0	-	-	9.4
HCM Lane LOS	A	A	-	-	A
HCM 95th %tile Q(veh)	0	-	-	-	0

Intersection						
Int Delay, s/veh	2.4					
Movement	EBL	EBT	WBT	WBR	SBL	SBR
Lane Configurations						
Traffic Vol, veh/h	28	52	114	17	16	43
Future Vol, veh/h	28	52	114	17	16	43
Conflicting Peds, #/hr	0	0	0	0	0	0
Sign Control	Free	Free	Free	Free	Stop	Stop
RT Channelized	-	None	-	None	-	None
Storage Length	135	-	-	-	0	-
Veh in Median Storage, #	-	0	0	-	0	-
Grade, %	-	6	6	-	0	-
Peak Hour Factor	93	93	60	60	92	92
Heavy Vehicles, %	2	2	2	2	2	2
Mvmt Flow	30	56	190	28	17	47

Major/Minor	Major1	Major2	Minor2		
Conflicting Flow All	218	0	-	0	320 204
Stage 1	-	-	-	-	204 -
Stage 2	-	-	-	-	116 -
Critical Hdwy	4.12	-	-	-	6.42 6.22
Critical Hdwy Stg 1	-	-	-	-	5.42 -
Critical Hdwy Stg 2	-	-	-	-	5.42 -
Follow-up Hdwy	2.218	-	-	-	3.518 3.318
Pot Cap-1 Maneuver	1352	-	-	-	673 837
Stage 1	-	-	-	-	830 -
Stage 2	-	-	-	-	909 -
Platoon blocked, %		-	-	-	
Mov Cap-1 Maneuver	1352	-	-	-	658 837
Mov Cap-2 Maneuver	-	-	-	-	658 -
Stage 1	-	-	-	-	812 -
Stage 2	-	-	-	-	909 -

Approach	EB	WB	SB
HCM Control Delay, s	2.7	0	10
HCM LOS			B

Minor Lane/Major Mvmt	EBL	EBT	WBT	WBR	SBLn1
Capacity (veh/h)	1352	-	-	-	779
HCM Lane V/C Ratio	0.022	-	-	-	0.082
HCM Control Delay (s)	7.7	-	-	-	10
HCM Lane LOS	A	-	-	-	B
HCM 95th %tile Q(veh)	0.1	-	-	-	0.3

Intersection						
Int Delay, s/veh	0.9					
Movement	EBL	EBT	WBT	WBR	SBL	SBR
Lane Configurations		↶	↷		↶	↷
Traffic Vol, veh/h	4	65	147	10	12	16
Future Vol, veh/h	4	65	147	10	12	16
Conflicting Peds, #/hr	0	0	0	0	0	0
Sign Control	Free	Free	Free	Free	Stop	Stop
RT Channelized	-	None	-	None	-	None
Storage Length	-	-	-	-	0	-
Veh in Median Storage, #	-	0	0	-	0	-
Grade, %	-	6	0	-	0	-
Peak Hour Factor	93	93	60	60	92	92
Heavy Vehicles, %	2	2	2	2	2	2
Mvmt Flow	4	70	245	17	13	17

Major/Minor	Major1	Major2	Minor2		
Conflicting Flow All	262	0	-	0	332 254
Stage 1	-	-	-	-	254 -
Stage 2	-	-	-	-	78 -
Critical Hdwy	4.12	-	-	-	6.42 6.22
Critical Hdwy Stg 1	-	-	-	-	5.42 -
Critical Hdwy Stg 2	-	-	-	-	5.42 -
Follow-up Hdwy	2.218	-	-	-	3.518 3.318
Pot Cap-1 Maneuver	1302	-	-	-	663 785
Stage 1	-	-	-	-	788 -
Stage 2	-	-	-	-	945 -
Platoon blocked, %		-	-	-	
Mov Cap-1 Maneuver	1302	-	-	-	661 785
Mov Cap-2 Maneuver	-	-	-	-	661 -
Stage 1	-	-	-	-	786 -
Stage 2	-	-	-	-	945 -

Approach	EB	WB	SB
HCM Control Delay, s	0.5	0	10.2
HCM LOS			B

Minor Lane/Major Mvmt	EBL	EBT	WBT	WBR	SBLn1
Capacity (veh/h)	1302	-	-	-	727
HCM Lane V/C Ratio	0.003	-	-	-	0.042
HCM Control Delay (s)	7.8	0	-	-	10.2
HCM Lane LOS	A	A	-	-	B
HCM 95th %tile Q(veh)	0	-	-	-	0.1

Intersection												
Int Delay, s/veh	9.5											
Movement	EBL	EBT	EBR	WBL	WBT	WBR	NBL	NBT	NBR	SBL	SBT	SBR
Lane Configurations	↖	↑	↗	↖	↑	↗		↖	↗		↕	
Traffic Vol, veh/h	50	230	46	22	490	25	54	15	16	20	26	120
Future Vol, veh/h	50	230	46	22	490	25	54	15	16	20	26	120
Conflicting Peds, #/hr	0	0	0	0	0	0	0	0	0	0	0	0
Sign Control	Free	Free	Free	Free	Free	Free	Stop	Stop	Stop	Stop	Stop	Stop
RT Channelized	-	-	None	-	-	None	-	-	None	-	-	None
Storage Length	310	-	420	330	-	-	-	-	140	-	-	-
Veh in Median Storage, #	-	0	-	-	0	-	-	0	-	-	0	-
Grade, %	-	0	-	-	0	-	-	0	-	-	0	-
Peak Hour Factor	94	94	94	95	95	95	72	72	72	83	83	83
Heavy Vehicles, %	2	2	2	2	2	2	2	2	2	2	2	2
Mvmt Flow	53	245	49	23	516	26	75	21	22	24	31	145

Major/Minor	Major1			Major2			Minor1			Minor2		
Conflicting Flow All	542	0	0	294	0	0	1014	939	245	972	975	529
Stage 1	-	-	-	-	-	-	351	351	-	575	575	-
Stage 2	-	-	-	-	-	-	663	588	-	397	400	-
Critical Hdwy	4.12	-	-	4.12	-	-	7.12	6.52	6.22	7.12	6.52	6.22
Critical Hdwy Stg 1	-	-	-	-	-	-	6.12	5.52	-	6.12	5.52	-
Critical Hdwy Stg 2	-	-	-	-	-	-	6.12	5.52	-	6.12	5.52	-
Follow-up Hdwy	2.218	-	-	2.218	-	-	3.518	4.018	3.318	3.518	4.018	3.318
Pot Cap-1 Maneuver	1027	-	-	1268	-	-	217	264	794	232	251	550
Stage 1	-	-	-	-	-	-	666	632	-	503	503	-
Stage 2	-	-	-	-	-	-	450	496	-	629	602	-
Platoon blocked, %	-	-	-	-	-	-	-	-	-	-	-	-
Mov Cap-1 Maneuver	1027	-	-	1268	-	-	136	246	794	200	234	550
Mov Cap-2 Maneuver	-	-	-	-	-	-	136	246	-	200	234	-
Stage 1	-	-	-	-	-	-	631	599	-	477	494	-
Stage 2	-	-	-	-	-	-	305	487	-	560	571	-

Approach	EB			WB			NB			SB		
HCM Control Delay, s	1.3			0.3			53			23.8		
HCM LOS							F			C		

Minor Lane/Major Mvmt	NBLn1	NBLn2	EBL	EBT	EBR	WBL	WBT	WBR	SBLn1
Capacity (veh/h)	151	794	1027	-	-	1268	-	-	387
HCM Lane V/C Ratio	0.635	0.028	0.052	-	-	0.018	-	-	0.517
HCM Control Delay (s)	63.1	9.7	8.7	-	-	7.9	-	-	23.8
HCM Lane LOS	F	A	A	-	-	A	-	-	C
HCM 95th %tile Q(veh)	3.5	0.1	0.2	-	-	0.1	-	-	2.9

Intersection												
Int Delay, s/veh	1.2											
Movement	EBL	EBT	EBR	WBL	WBT	WBR	NBL	NBT	NBR	SBL	SBT	SBR
Lane Configurations		↕			↕			↕			↕	
Traffic Vol, veh/h	1	0	3	3	0	1	5	41	5	4	50	3
Future Vol, veh/h	1	0	3	3	0	1	5	41	5	4	50	3
Conflicting Peds, #/hr	0	0	0	0	0	0	0	0	0	0	0	0
Sign Control	Stop	Stop	Stop	Stop	Stop	Stop	Free	Free	Free	Free	Free	Free
RT Channelized	-	-	None	-	-	None	-	-	None	-	-	None
Storage Length	-	-	-	-	-	-	-	-	-	-	-	-
Veh in Median Storage, #	-	0	-	-	0	-	-	0	-	-	0	-
Grade, %	-	0	-	-	0	-	-	0	-	-	0	-
Peak Hour Factor	92	92	92	92	92	92	92	92	92	92	92	92
Heavy Vehicles, %	2	2	2	2	2	2	2	2	2	2	2	2
Mvmt Flow	1	0	3	3	0	1	5	45	5	4	54	3

Major/Minor	Minor2		Minor1		Major1			Major2				
Conflicting Flow All	122	124	56	123	123	48	57	0	0	50	0	0
Stage 1	64	64	-	58	58	-	-	-	-	-	-	-
Stage 2	58	60	-	65	65	-	-	-	-	-	-	-
Critical Hdwy	7.12	6.52	6.22	7.12	6.52	6.22	4.12	-	-	4.12	-	-
Critical Hdwy Stg 1	6.12	5.52	-	6.12	5.52	-	-	-	-	-	-	-
Critical Hdwy Stg 2	6.12	5.52	-	6.12	5.52	-	-	-	-	-	-	-
Follow-up Hdwy	3.518	4.018	3.318	3.518	4.018	3.318	2.218	-	-	2.218	-	-
Pot Cap-1 Maneuver	853	766	1011	852	767	1021	1547	-	-	1557	-	-
Stage 1	947	842	-	954	847	-	-	-	-	-	-	-
Stage 2	954	845	-	946	841	-	-	-	-	-	-	-
Platoon blocked, %								-	-	-	-	-
Mov Cap-1 Maneuver	848	761	1011	845	762	1021	1547	-	-	1557	-	-
Mov Cap-2 Maneuver	848	761	-	845	762	-	-	-	-	-	-	-
Stage 1	944	839	-	951	844	-	-	-	-	-	-	-
Stage 2	950	842	-	940	838	-	-	-	-	-	-	-

Approach	EB		WB		NB		SB	
HCM Control Delay, s	8.7		9.1		0.7		0.5	
HCM LOS	A		A					

Minor Lane/Major Mvmt	NBL	NBT	NBR	EBLn1	WBLn1	SBL	SBT	SBR
Capacity (veh/h)	1547	-	-	965	883	1557	-	-
HCM Lane V/C Ratio	0.004	-	-	0.005	0.005	0.003	-	-
HCM Control Delay (s)	7.3	0	-	8.7	9.1	7.3	0	-
HCM Lane LOS	A	A	-	A	A	A	A	-
HCM 95th %tile Q(veh)	0	-	-	0	0	0	-	-

Intersection						
Int Delay, s/veh	0.5					
Movement	EBL	EBT	WBT	WBR	SBL	SBR
Lane Configurations		↶	↷		↶	
Traffic Vol, veh/h	7	114	96	2	1	7
Future Vol, veh/h	7	114	96	2	1	7
Conflicting Peds, #/hr	0	0	0	0	0	0
Sign Control	Free	Free	Free	Free	Stop	Stop
RT Channelized	-	None	-	None	-	None
Storage Length	-	-	-	-	0	-
Veh in Median Storage, #	-	0	0	-	0	-
Grade, %	-	0	0	-	0	-
Peak Hour Factor	88	88	98	98	92	92
Heavy Vehicles, %	2	2	2	2	2	2
Mvmt Flow	8	130	98	2	1	8

Major/Minor	Major1	Major2	Minor2		
Conflicting Flow All	100	0	-	0	245 99
Stage 1	-	-	-	-	99 -
Stage 2	-	-	-	-	146 -
Critical Hdwy	4.12	-	-	-	6.42 6.22
Critical Hdwy Stg 1	-	-	-	-	5.42 -
Critical Hdwy Stg 2	-	-	-	-	5.42 -
Follow-up Hdwy	2.218	-	-	-	3.518 3.318
Pot Cap-1 Maneuver	1493	-	-	-	743 957
Stage 1	-	-	-	-	925 -
Stage 2	-	-	-	-	881 -
Platoon blocked, %		-	-	-	
Mov Cap-1 Maneuver	1493	-	-	-	739 957
Mov Cap-2 Maneuver	-	-	-	-	739 -
Stage 1	-	-	-	-	919 -
Stage 2	-	-	-	-	881 -

Approach	EB	WB	SB
HCM Control Delay, s	0.4	0	8.9
HCM LOS			A

Minor Lane/Major Mvmt	EBL	EBT	WBT	WBR	SBLn1
Capacity (veh/h)	1493	-	-	-	923
HCM Lane V/C Ratio	0.005	-	-	-	0.009
HCM Control Delay (s)	7.4	0	-	-	8.9
HCM Lane LOS	A	A	-	-	A
HCM 95th %tile Q(veh)	0	-	-	-	0

Intersection						
Int Delay, s/veh	2.7					
Movement	EBL	EBT	WBT	WBR	SBL	SBR
Lane Configurations						
Traffic Vol, veh/h	39	113	91	11	18	38
Future Vol, veh/h	39	113	91	11	18	38
Conflicting Peds, #/hr	0	0	0	0	0	0
Sign Control	Free	Free	Free	Free	Stop	Stop
RT Channelized	-	None	-	None	-	None
Storage Length	135	-	-	-	0	-
Veh in Median Storage, #	-	0	0	-	0	-
Grade, %	-	6	6	-	0	-
Peak Hour Factor	88	88	98	98	92	92
Heavy Vehicles, %	2	2	2	2	2	2
Mvmt Flow	44	128	93	11	20	41

Major/Minor	Major1	Major2	Minor2		
Conflicting Flow All	104	0	-	0	315 99
Stage 1	-	-	-	-	99 -
Stage 2	-	-	-	-	216 -
Critical Hdwy	4.12	-	-	-	6.42 6.22
Critical Hdwy Stg 1	-	-	-	-	5.42 -
Critical Hdwy Stg 2	-	-	-	-	5.42 -
Follow-up Hdwy	2.218	-	-	-	3.518 3.318
Pot Cap-1 Maneuver	1488	-	-	-	678 957
Stage 1	-	-	-	-	925 -
Stage 2	-	-	-	-	820 -
Platoon blocked, %		-	-	-	
Mov Cap-1 Maneuver	1488	-	-	-	658 957
Mov Cap-2 Maneuver	-	-	-	-	658 -
Stage 1	-	-	-	-	897 -
Stage 2	-	-	-	-	820 -

Approach	EB	WB	SB
HCM Control Delay, s	1.9	0	9.7
HCM LOS			A

Minor Lane/Major Mvmt	EBL	EBT	WBT	WBR	SBLn1
Capacity (veh/h)	1488	-	-	-	835
HCM Lane V/C Ratio	0.03	-	-	-	0.073
HCM Control Delay (s)	7.5	-	-	-	9.7
HCM Lane LOS	A	-	-	-	A
HCM 95th %tile Q(veh)	0.1	-	-	-	0.2



Intersection						
Int Delay, s/veh	1.6					
Movement	EBL	EBT	WBT	WBR	SBL	SBR
Lane Configurations		↕	↕		↕	
Traffic Vol, veh/h	25	132	114	15	18	14
Future Vol, veh/h	25	132	114	15	18	14
Conflicting Peds, #/hr	0	0	0	0	0	0
Sign Control	Free	Free	Free	Free	Stop	Stop
RT Channelized	-	None	-	None	-	None
Storage Length	-	-	-	-	0	-
Veh in Median Storage, #	-	0	0	-	0	-
Grade, %	-	6	0	-	0	-
Peak Hour Factor	88	88	98	98	100	100
Heavy Vehicles, %	2	2	2	2	2	2
Mvmt Flow	28	150	116	15	18	14

Major/Minor	Major1	Major2	Minor2		
Conflicting Flow All	131	0	-	0	330 124
Stage 1	-	-	-	-	124 -
Stage 2	-	-	-	-	206 -
Critical Hdwy	4.12	-	-	-	6.42 6.22
Critical Hdwy Stg 1	-	-	-	-	5.42 -
Critical Hdwy Stg 2	-	-	-	-	5.42 -
Follow-up Hdwy	2.218	-	-	-	3.518 3.318
Pot Cap-1 Maneuver	1454	-	-	-	665 927
Stage 1	-	-	-	-	902 -
Stage 2	-	-	-	-	829 -
Platoon blocked, %		-	-	-	
Mov Cap-1 Maneuver	1454	-	-	-	651 927
Mov Cap-2 Maneuver	-	-	-	-	651 -
Stage 1	-	-	-	-	883 -
Stage 2	-	-	-	-	829 -

Approach	EB	WB	SB
HCM Control Delay, s	1.2	0	10
HCM LOS			B

Minor Lane/Major Mvmt	EBL	EBT	WBT	WBR	SBLn1
Capacity (veh/h)	1454	-	-	-	748
HCM Lane V/C Ratio	0.02	-	-	-	0.043
HCM Control Delay (s)	7.5	0	-	-	10
HCM Lane LOS	A	A	-	-	B
HCM 95th %tile Q(veh)	0.1	-	-	-	0.1

Intersection												
Int Delay, s/veh	10.2											
Movement	EBL	EBT	EBR	WBL	WBT	WBR	NBL	NBT	NBR	SBL	SBT	SBR
Lane Configurations												
Traffic Vol, veh/h	130	425	58	28	340	30	42	15	21	20	26	105
Future Vol, veh/h	130	425	58	28	340	30	42	15	21	20	26	105
Conflicting Peds, #/hr	0	0	0	0	0	0	0	0	0	0	0	0
Sign Control	Free	Free	Free	Free	Free	Free	Stop	Stop	Stop	Stop	Stop	Stop
RT Channelized	-	-	None	-	-	None	-	-	None	-	-	None
Storage Length	310	-	420	330	-	-	-	-	140	-	-	-
Veh in Median Storage, #	-	0	-	-	0	-	-	0	-	-	0	-
Grade, %	-	0	-	-	0	-	-	0	-	-	0	-
Peak Hour Factor	100	100	100	86	86	86	76	76	76	90	90	90
Heavy Vehicles, %	2	2	2	2	2	2	2	2	2	2	2	2
Mvmt Flow	130	425	58	33	395	35	55	20	28	22	29	117

























Major/Minor	Major1		Major2		Minor1			Minor2				
Conflicting Flow All	430	0	0	483	0	0	1237	1181	425	1217	1222	413
Stage 1	-	-	-	-	-	-	685	685	-	479	479	-
Stage 2	-	-	-	-	-	-	552	496	-	738	743	-
Critical Hdwy	4.12	-	-	4.12	-	-	7.12	6.52	6.22	7.12	6.52	6.22
Critical Hdwy Stg 1	-	-	-	-	-	-	6.12	5.52	-	6.12	5.52	-
Critical Hdwy Stg 2	-	-	-	-	-	-	6.12	5.52	-	6.12	5.52	-
Follow-up Hdwy	2.218	-	-	2.218	-	-	3.518	4.018	3.318	3.518	4.018	3.318
Pot Cap-1 Maneuver	1129	-	-	1080	-	-	153	190	629	158	180	639
Stage 1	-	-	-	-	-	-	438	448	-	568	555	-
Stage 2	-	-	-	-	-	-	518	545	-	410	422	-
Platoon blocked, %	-	-	-	-	-	-	-	-	-	-	-	-
Mov Cap-1 Maneuver	1129	-	-	1080	-	-	96	163	629	122	154	639
Mov Cap-2 Maneuver	-	-	-	-	-	-	96	163	-	122	154	-
Stage 1	-	-	-	-	-	-	388	396	-	503	538	-
Stage 2	-	-	-	-	-	-	388	528	-	330	373	-

Approach	EB		WB		NB			SB		
HCM Control Delay, s	1.8		0.6		70.6			30.5		
HCM LOS					F			D		

Minor Lane/Major Mvmt	NBLn1	NBLn2	EBL	EBT	EBR	WBL	WBT	WBR	SBLn1
Capacity (veh/h)	108	629	1129	-	-	1080	-	-	304
HCM Lane V/C Ratio	0.694	0.044	0.115	-	-	0.03	-	-	0.552
HCM Control Delay (s)	92.6	11	8.6	-	-	8.4	-	-	30.5
HCM Lane LOS	F	B	A	-	-	A	-	-	D
HCM 95th %tile Q(veh)	3.6	0.1	0.4	-	-	0.1	-	-	3.1

Lanes, Volumes, Timings  
14: Furrow Rd & Hwy 105

2040 Background  
AM (Signal)

												
Lane Group	EBL	EBT	EBR	WBL	WBT	WBR	NBL	NBT	NBR	SBL	SBT	SBR
Lane Configurations												
Traffic Volume (vph)	55	290	75	50	810	25	125	75	50	35	50	155
Future Volume (vph)	55	290	75	50	810	25	125	75	50	35	50	155
Ideal Flow (vphpl)	1900	1900	1900	1900	1900	1900	1900	1900	1900	1900	1900	1900
Storage Length (ft)	310		420	330		235	140		0	140		140
Storage Lanes	1		1	1		1	1		0	1		1
Taper Length (ft)	125			155			105			135		
Lane Util. Factor	1.00	0.95	1.00	1.00	0.95	1.00	1.00	1.00	1.00	1.00	1.00	1.00
Frt			0.850			0.850		0.940				0.850
Flt Protected	0.950			0.950			0.950			0.950		
Satd. Flow (prot)	1770	3539	1583	1770	3539	1583	1770	1751	0	1770	1863	1583
Flt Permitted	0.249			0.574			0.458			0.663		
Satd. Flow (perm)	464	3539	1583	1069	3539	1583	853	1751	0	1235	1863	1583
Right Turn on Red			Yes			Yes			Yes			Yes
Satd. Flow (RTOR)			127			127		39				163
Link Speed (mph)		50			50			25				35
Link Distance (ft)		959			1048			712				530
Travel Time (s)		13.1			14.3			19.4				10.3
Peak Hour Factor	1.00	1.00	1.00	1.00	1.00	1.00	0.85	0.85	0.85	0.95	0.95	0.95
Adj. Flow (vph)	55	290	75	50	810	25	147	88	59	37	53	163
Shared Lane Traffic (%)												
Lane Group Flow (vph)	55	290	75	50	810	25	147	147	0	37	53	163
Enter Blocked Intersection	No	No	No	No	No	No	No	No	No	No	No	No
Lane Alignment	Left	Left	Right	Left	Left	Right	Left	Left	Right	Left	Left	Right
Median Width(ft)		12			12			12				12
Link Offset(ft)		0			0			0				0
Crosswalk Width(ft)		16			16			16				16
Two way Left Turn Lane												
Headway Factor	1.00	1.00	1.00	1.00	1.00	1.00	1.00	1.00	1.00	1.00	1.00	1.00
Turning Speed (mph)	15		9	15		9	15		9	15		9
Number of Detectors	1	2	1	1	2	1	1	2		1	2	1
Detector Template	Left	Thru	Right	Left	Thru	Right	Left	Thru		Left	Thru	Right
Leading Detector (ft)	20	100	20	20	100	20	20	100		20	100	20
Trailing Detector (ft)	0	0	0	0	0	0	0	0		0	0	0
Detector 1 Position(ft)	0	0	0	0	0	0	0	0		0	0	0
Detector 1 Size(ft)	20	6	20	20	6	20	20	6		20	6	20
Detector 1 Type	Cl+Ex	Cl+Ex	Cl+Ex	Cl+Ex	Cl+Ex	Cl+Ex	Cl+Ex	Cl+Ex		Cl+Ex	Cl+Ex	Cl+Ex
Detector 1 Channel												
Detector 1 Extend (s)	0.0	0.0	0.0	0.0	0.0	0.0	0.0	0.0		0.0	0.0	0.0
Detector 1 Queue (s)	0.0	0.0	0.0	0.0	0.0	0.0	0.0	0.0		0.0	0.0	0.0
Detector 1 Delay (s)	0.0	0.0	0.0	0.0	0.0	0.0	0.0	0.0		0.0	0.0	0.0
Detector 2 Position(ft)		94			94			94				94
Detector 2 Size(ft)		6			6			6				6
Detector 2 Type		Cl+Ex			Cl+Ex			Cl+Ex				Cl+Ex
Detector 2 Channel												
Detector 2 Extend (s)		0.0			0.0			0.0				0.0
Turn Type	pm+pt	NA	Perm	pm+pt	NA	Perm	pm+pt	NA		Perm	NA	Perm
Protected Phases	7	4		3	8		5	2				6
Permitted Phases	4		4	8		8	2			6		6

Lanes, Volumes, Timings  
14: Furrow Rd & Hwy 105

2040 Background  
AM (Signal)

Lane Group	EBL	EBT	EBR	WBL	WBT	WBR	NBL	NBT	NBR	SBL	SBT	SBR
Detector Phase	7	4	4	3	8	8	5	2		6	6	6
Switch Phase												
Minimum Initial (s)	5.0	5.0	5.0	5.0	5.0	5.0	5.0	5.0		5.0	5.0	5.0
Minimum Split (s)	9.5	22.5	22.5	9.5	22.5	22.5	9.5	22.5		22.5	22.5	22.5
Total Split (s)	9.5	48.0	48.0	9.5	48.0	48.0	9.5	32.5		23.0	23.0	23.0
Total Split (%)	10.6%	53.3%	53.3%	10.6%	53.3%	53.3%	10.6%	36.1%		25.6%	25.6%	25.6%
Maximum Green (s)	5.0	43.5	43.5	5.0	43.5	43.5	5.0	28.0		18.5	18.5	18.5
Yellow Time (s)	3.5	3.5	3.5	3.5	3.5	3.5	3.5	3.5		3.5	3.5	3.5
All-Red Time (s)	1.0	1.0	1.0	1.0	1.0	1.0	1.0	1.0		1.0	1.0	1.0
Lost Time Adjust (s)	0.0	0.0	0.0	0.0	0.0	0.0	0.0	0.0		0.0	0.0	0.0
Total Lost Time (s)	4.5	4.5	4.5	4.5	4.5	4.5	4.5	4.5		4.5	4.5	4.5
Lead/Lag	Lead	Lag	Lag	Lead	Lag	Lag	Lead			Lag	Lag	Lag
Lead-Lag Optimize?	Yes	Yes	Yes	Yes	Yes	Yes	Yes			Yes	Yes	Yes
Vehicle Extension (s)	3.0	3.0	3.0	3.0	3.0	3.0	3.0	3.0		3.0	3.0	3.0
Recall Mode	None	None	None	None	None	None	None	Min		Min	Min	Min
Walk Time (s)		7.0	7.0		7.0	7.0		7.0		7.0	7.0	7.0
Flash Dont Walk (s)		11.0	11.0		11.0	11.0		11.0		11.0	11.0	11.0
Pedestrian Calls (#/hr)		0	0		0	0		0		0	0	0
Act Effct Green (s)	21.8	19.3	19.3	21.8	19.3	19.3	14.8	14.8		7.8	7.8	7.8
Actuated g/C Ratio	0.45	0.40	0.40	0.45	0.40	0.40	0.30	0.30		0.16	0.16	0.16
v/c Ratio	0.15	0.21	0.11	0.09	0.58	0.04	0.41	0.26		0.19	0.18	0.42
Control Delay	7.7	11.8	1.3	7.1	14.9	0.1	19.1	13.2		25.3	24.0	8.8
Queue Delay	0.0	0.0	0.0	0.0	0.0	0.0	0.0	0.0		0.0	0.0	0.0
Total Delay	7.7	11.8	1.3	7.1	14.9	0.1	19.1	13.2		25.3	24.0	8.8
LOS	A	B	A	A	B	A	B	B		C	C	A
Approach Delay		9.4			14.0			16.2			14.4	
Approach LOS		A			B			B			B	

Intersection Summary

Area Type:	Other
Cycle Length:	90
Actuated Cycle Length:	48.8
Natural Cycle:	65
Control Type:	Actuated-Uncoordinated
Maximum v/c Ratio:	0.58
Intersection Signal Delay:	13.4
Intersection LOS:	B
Intersection Capacity Utilization:	52.7%
ICU Level of Service:	A
Analysis Period (min):	15

Splits and Phases: 14: Furrow Rd & Hwy 105

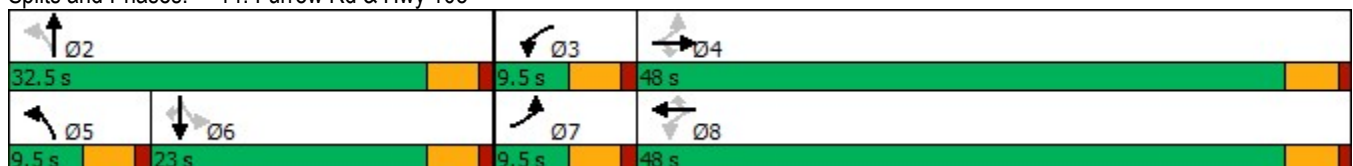

Intersection						
Int Delay, s/veh	2.4					
Movement	EBT	EBR	WBL	WBT	NBL	NBR
Lane Configurations						
Traffic Vol, veh/h	150	10	60	190	20	50
Future Vol, veh/h	150	10	60	190	20	50
Conflicting Peds, #/hr	0	0	0	0	0	0
Sign Control	Free	Free	Free	Free	Stop	Stop
RT Channelized	-	None	-	None	-	None
Storage Length	-	-	135	-	0	-
Veh in Median Storage, #	0	-	-	0	0	-
Grade, %	0	-	-	0	0	-
Peak Hour Factor	95	95	85	85	95	95
Heavy Vehicles, %	2	2	2	2	2	2
Mvmt Flow	158	11	71	224	21	53

Major/Minor	Major1	Major2	Minor1	Minor2	Minor3
Conflicting Flow All	0	0	169	0	530
Stage 1	-	-	-	-	164
Stage 2	-	-	-	-	366
Critical Hdwy	-	-	4.12	-	6.42
Critical Hdwy Stg 1	-	-	-	-	5.42
Critical Hdwy Stg 2	-	-	-	-	5.42
Follow-up Hdwy	-	-	2.218	-	3.518
Pot Cap-1 Maneuver	-	-	1409	-	510
Stage 1	-	-	-	-	865
Stage 2	-	-	-	-	702
Platoon blocked, %	-	-	-	-	-
Mov Cap-1 Maneuver	-	-	1409	-	485
Mov Cap-2 Maneuver	-	-	-	-	485
Stage 1	-	-	-	-	865
Stage 2	-	-	-	-	667

Approach	EB	WB	NB
HCM Control Delay, s	0	1.8	10.6
HCM LOS			B

Minor Lane/Major Mvmt	NBLn1	EBT	EBR	WBL	WBT
Capacity (veh/h)	714	-	-	1409	-
HCM Lane V/C Ratio	0.103	-	-	0.05	-
HCM Control Delay (s)	10.6	-	-	7.7	-
HCM Lane LOS	B	-	-	A	-
HCM 95th %tile Q(veh)	0.3	-	-	0.2	-

Intersection												
Int Delay, s/veh	8.9											
Movement	EBL	EBT	EBR	WBL	WBT	WBR	NBL	NBT	NBR	SBL	SBT	SBR
Lane Configurations	↖	↗	↖	↖	↗	↖	↖	↗	↖	↖	↗	↖
Traffic Vol, veh/h	75	100	50	10	150	50	100	150	25	25	75	75
Future Vol, veh/h	75	100	50	10	150	50	100	150	25	25	75	75
Conflicting Peds, #/hr	0	0	0	0	0	0	0	0	0	0	0	0
Sign Control	Free	Free	Free	Free	Free	Free	Stop	Stop	Stop	Stop	Stop	Stop
RT Channelized	-	-	None	-	-	None	-	-	None	-	-	None
Storage Length	135	-	135	135	-	135	115	-	115	115	-	115
Veh in Median Storage, #	-	0	-	-	0	-	-	0	-	-	0	-
Grade, %	-	6	-	-	6	-	-	0	-	-	0	-
Peak Hour Factor	95	95	95	85	85	85	95	95	95	95	95	95
Heavy Vehicles, %	2	2	2	2	2	2	2	2	2	2	2	2
Mvmt Flow	79	105	53	12	176	59	105	158	26	26	79	79

Major/Minor	Major1			Major2			Minor1			Minor2		
Conflicting Flow All	235	0	0	158	0	0	572	522	105	582	516	176
Stage 1	-	-	-	-	-	-	263	263	-	200	200	-
Stage 2	-	-	-	-	-	-	309	259	-	382	316	-
Critical Hdwy	4.12	-	-	4.12	-	-	7.12	6.52	6.22	7.12	6.52	6.22
Critical Hdwy Stg 1	-	-	-	-	-	-	6.12	5.52	-	6.12	5.52	-
Critical Hdwy Stg 2	-	-	-	-	-	-	6.12	5.52	-	6.12	5.52	-
Follow-up Hdwy	2.218	-	-	2.218	-	-	3.518	4.018	3.318	3.518	4.018	3.318
Pot Cap-1 Maneuver	1332	-	-	1422	-	-	431	459	949	424	463	867
Stage 1	-	-	-	-	-	-	742	691	-	802	736	-
Stage 2	-	-	-	-	-	-	701	694	-	640	655	-
Platoon blocked, %	-	-	-	-	-	-	-	-	-	-	-	-
Mov Cap-1 Maneuver	1332	-	-	1422	-	-	320	428	949	280	432	867
Mov Cap-2 Maneuver	-	-	-	-	-	-	320	428	-	280	432	-
Stage 1	-	-	-	-	-	-	698	650	-	755	730	-
Stage 2	-	-	-	-	-	-	563	688	-	443	616	-

Approach	EB			WB			NB			SB		
HCM Control Delay, s	2.6			0.4			18.6			13.4		
HCM LOS							C			B		

Minor Lane/Major Mvmt	NBLn1	NBLn2	NBLn3	EBL	EBT	EBR	WBL	WBT	WBR	SBLn1	SBLn2	SBLn3
Capacity (veh/h)	320	428	949	1332	-	-	1422	-	-	280	432	867
HCM Lane V/C Ratio	0.329	0.369	0.028	0.059	-	-	0.008	-	-	0.094	0.183	0.091
HCM Control Delay (s)	21.7	18.2	8.9	7.9	-	-	7.6	-	-	19.2	15.2	9.6
HCM Lane LOS	C	C	A	A	-	-	A	-	-	C	C	A
HCM 95th %tile Q(veh)	1.4	1.7	0.1	0.2	-	-	0	-	-	0.3	0.7	0.3

Intersection						
Int Delay, s/veh	0.7					
Movement	EBL	EBT	WBT	WBR	SBL	SBR
Lane Configurations		↕	↕		↕	
Traffic Vol, veh/h	5	210	310	15	15	20
Future Vol, veh/h	5	210	310	15	15	20
Conflicting Peds, #/hr	0	0	0	0	0	0
Sign Control	Free	Free	Free	Free	Stop	Stop
RT Channelized	-	None	-	None	-	None
Storage Length	-	-	-	-	0	-
Veh in Median Storage, #	-	0	0	-	0	-
Grade, %	-	6	0	-	0	-
Peak Hour Factor	95	95	85	85	95	95
Heavy Vehicles, %	2	2	2	2	2	2
Mvmt Flow	5	221	365	18	16	21

Major/Minor	Major1	Major2	Minor2		
Conflicting Flow All	383	0	-	0	605 374
Stage 1	-	-	-	-	374 -
Stage 2	-	-	-	-	231 -
Critical Hdwy	4.12	-	-	-	6.42 6.22
Critical Hdwy Stg 1	-	-	-	-	5.42 -
Critical Hdwy Stg 2	-	-	-	-	5.42 -
Follow-up Hdwy	2.218	-	-	-	3.518 3.318
Pot Cap-1 Maneuver	1175	-	-	-	461 672
Stage 1	-	-	-	-	696 -
Stage 2	-	-	-	-	807 -
Platoon blocked, %		-	-	-	
Mov Cap-1 Maneuver	1175	-	-	-	459 672
Mov Cap-2 Maneuver	-	-	-	-	459 -
Stage 1	-	-	-	-	693 -
Stage 2	-	-	-	-	807 -

Approach	EB	WB	SB
HCM Control Delay, s	0.2	0	11.9
HCM LOS			B

Minor Lane/Major Mvmt	EBL	EBT	WBT	WBR	SBLn1
Capacity (veh/h)	1175	-	-	-	561
HCM Lane V/C Ratio	0.004	-	-	-	0.066
HCM Control Delay (s)	8.1	0	-	-	11.9
HCM Lane LOS	A	A	-	-	B
HCM 95th %tile Q(veh)	0	-	-	-	0.2

Intersection												
Int Delay, s/veh	37.1											
Movement	EBL	EBT	EBR	WBL	WBT	WBR	NBL	NBT	NBR	SBL	SBT	SBR
Lane Configurations	↖	↗	↘	↖	↗	↘	↖	↗	↘	↖	↗	↘
Traffic Vol, veh/h	55	290	75	50	810	25	125	75	50	35	50	155
Future Vol, veh/h	55	290	75	50	810	25	125	75	50	35	50	155
Conflicting Peds, #/hr	0	0	0	0	0	0	0	0	0	0	0	0
Sign Control	Free	Free	Free	Free	Free	Free	Stop	Stop	Stop	Stop	Stop	Stop
RT Channelized	-	-	None	-	-	None	-	-	None	-	-	None
Storage Length	310	-	420	330	-	235	140	-	-	140	-	140
Veh in Median Storage, #	-	0	-	-	0	-	-	0	-	-	0	-
Grade, %	-	0	-	-	0	-	-	0	-	-	0	-
Peak Hour Factor	100	100	100	100	100	100	85	85	85	95	95	95
Heavy Vehicles, %	2	2	2	2	2	2	2	2	2	2	2	2
Mvmt Flow	55	290	75	50	810	25	147	88	59	37	53	163

Major/Minor	Major1			Major2			Minor1			Minor2		
Conflicting Flow All	835	0	0	365	0	0	932	1335	145	1209	1385	405
Stage 1	-	-	-	-	-	-	400	400	-	910	910	-
Stage 2	-	-	-	-	-	-	532	935	-	299	475	-
Critical Hdwy	4.14	-	-	4.14	-	-	7.54	6.54	6.94	7.54	6.54	6.94
Critical Hdwy Stg 1	-	-	-	-	-	-	6.54	5.54	-	6.54	5.54	-
Critical Hdwy Stg 2	-	-	-	-	-	-	6.54	5.54	-	6.54	5.54	-
Follow-up Hdwy	2.22	-	-	2.22	-	-	3.52	4.02	3.32	3.52	4.02	3.32
Pot Cap-1 Maneuver	794	-	-	1190	-	-	221	152	876	139	142	595
Stage 1	-	-	-	-	-	-	597	600	-	296	352	-
Stage 2	-	-	-	-	-	-	499	342	-	685	556	-
Platoon blocked, %	-	-	-	-	-	-	-	-	-	-	-	-
Mov Cap-1 Maneuver	794	-	-	1190	-	-	~ 100	136	876	58	127	595
Mov Cap-2 Maneuver	-	-	-	-	-	-	~ 100	136	-	58	127	-
Stage 1	-	-	-	-	-	-	556	559	-	276	337	-
Stage 2	-	-	-	-	-	-	293	328	-	501	518	-

Approach	EB			WB			NB			SB		
HCM Control Delay, s	1.3			0.5			195.8			40.1		
HCM LOS							F			E		























Minor Lane/Major Mvmt	NBLn1	NBLn2	EBL	EBT	EBR	WBL	WBT	WBR	SBLn1	SBLn2	SBLn3
Capacity (veh/h)	100	205	794	-	-	1190	-	-	58	127	595
HCM Lane V/C Ratio	1.471	0.717	0.069	-	-	0.042	-	-	0.635	0.414	0.274
HCM Control Delay (s)	\$ 334.1	57.5	9.9	-	-	8.2	-	-	141.4	52.1	13.3
HCM Lane LOS	F	F	A	-	-	A	-	-	F	F	B
HCM 95th %tile Q(veh)	10.9	4.6	0.2	-	-	0.1	-	-	2.6	1.8	1.1

Notes  
 ~: Volume exceeds capacity    \$: Delay exceeds 300s    +: Computation Not Defined    \*: All major volume in platoon



Lanes, Volumes, Timings  
14: Furrow Rd & Hwy 105

2040 Background  
PM (Signal)

												
Lane Group	EBL	EBT	EBR	WBL	WBT	WBR	NBL	NBT	NBR	SBL	SBT	SBR
Lane Configurations												
Traffic Volume (vph)	130	680	150	50	535	65	70	50	75	30	75	75
Future Volume (vph)	130	680	150	50	535	65	70	50	75	30	75	75
Ideal Flow (vphpl)	1900	1900	1900	1900	1900	1900	1900	1900	1900	1900	1900	1900
Storage Length (ft)	310		420	330		235	140		0	140		140
Storage Lanes	1		1	1		1	1		0	1		1
Taper Length (ft)	125			155			105			135		
Lane Util. Factor	1.00	1.00	1.00	1.00	1.00	1.00	1.00	1.00	1.00	1.00	1.00	1.00
Frt			0.850			0.850		0.910				0.850
Flt Protected	0.950			0.950			0.950			0.950		
Satd. Flow (prot)	1770	1863	1583	1770	1863	1583	1770	1695	0	1770	1863	1583
Flt Permitted	0.290			0.198			0.472			0.663		
Satd. Flow (perm)	540	1863	1583	369	1863	1583	879	1695	0	1235	1863	1583
Right Turn on Red			Yes			Yes			Yes			Yes
Satd. Flow (RTOR)			150			127		87				127
Link Speed (mph)		50			50			25				35
Link Distance (ft)		959			1048			712				530
Travel Time (s)		13.1			14.3			19.4				10.3
Peak Hour Factor	1.00	1.00	1.00	1.00	1.00	1.00	0.85	0.85	0.85	0.95	0.95	0.95
Adj. Flow (vph)	130	680	150	50	535	65	82	59	88	32	79	79
Shared Lane Traffic (%)												
Lane Group Flow (vph)	130	680	150	50	535	65	82	147	0	32	79	79
Enter Blocked Intersection	No	No	No	No	No	No	No	No	No	No	No	No
Lane Alignment	Left	Left	Right	Left	Left	Right	Left	Left	Right	Left	Left	Right
Median Width(ft)		12			12			12				12
Link Offset(ft)		0			0			0				0
Crosswalk Width(ft)		16			16			16				16
Two way Left Turn Lane												
Headway Factor	1.00	1.00	1.00	1.00	1.00	1.00	1.00	1.00	1.00	1.00	1.00	1.00
Turning Speed (mph)	15		9	15		9	15		9	15		9
Number of Detectors	1	2	1	1	2	1	1	2		1	2	1
Detector Template	Left	Thru	Right	Left	Thru	Right	Left	Thru		Left	Thru	Right
Leading Detector (ft)	20	100	20	20	100	20	20	100		20	100	20
Trailing Detector (ft)	0	0	0	0	0	0	0	0		0	0	0
Detector 1 Position(ft)	0	0	0	0	0	0	0	0		0	0	0
Detector 1 Size(ft)	20	6	20	20	6	20	20	6		20	6	20
Detector 1 Type	Cl+Ex	Cl+Ex	Cl+Ex	Cl+Ex	Cl+Ex	Cl+Ex	Cl+Ex	Cl+Ex		Cl+Ex	Cl+Ex	Cl+Ex
Detector 1 Channel												
Detector 1 Extend (s)	0.0	0.0	0.0	0.0	0.0	0.0	0.0	0.0		0.0	0.0	0.0
Detector 1 Queue (s)	0.0	0.0	0.0	0.0	0.0	0.0	0.0	0.0		0.0	0.0	0.0
Detector 1 Delay (s)	0.0	0.0	0.0	0.0	0.0	0.0	0.0	0.0		0.0	0.0	0.0
Detector 2 Position(ft)		94			94			94				94
Detector 2 Size(ft)		6			6			6				6
Detector 2 Type		Cl+Ex			Cl+Ex			Cl+Ex				Cl+Ex
Detector 2 Channel												
Detector 2 Extend (s)		0.0			0.0			0.0				0.0
Turn Type	pm+pt	NA	Perm	pm+pt	NA	Perm	pm+pt	NA		Perm	NA	Perm
Protected Phases	7	4		3	8		5	2				6
Permitted Phases	4		4	8		8	2			6		6

Lanes, Volumes, Timings  
14: Furrow Rd & Hwy 105

2040 Background  
PM (Signal)

Lane Group	EBL	EBT	EBR	WBL	WBT	WBR	NBL	NBT	NBR	SBL	SBT	SBR
Detector Phase	7	4	4	3	8	8	5	2		6	6	6
Switch Phase												
Minimum Initial (s)	5.0	5.0	5.0	5.0	5.0	5.0	5.0	5.0		5.0	5.0	5.0
Minimum Split (s)	9.5	22.5	22.5	9.5	22.5	22.5	9.5	22.5		22.5	22.5	22.5
Total Split (s)	9.5	48.0	48.0	9.5	48.0	48.0	9.5	32.5		23.0	23.0	23.0
Total Split (%)	10.6%	53.3%	53.3%	10.6%	53.3%	53.3%	10.6%	36.1%		25.6%	25.6%	25.6%
Maximum Green (s)	5.0	43.5	43.5	5.0	43.5	43.5	5.0	28.0		18.5	18.5	18.5
Yellow Time (s)	3.5	3.5	3.5	3.5	3.5	3.5	3.5	3.5		3.5	3.5	3.5
All-Red Time (s)	1.0	1.0	1.0	1.0	1.0	1.0	1.0	1.0		1.0	1.0	1.0
Lost Time Adjust (s)	0.0	0.0	0.0	0.0	0.0	0.0	0.0	0.0		0.0	0.0	0.0
Total Lost Time (s)	4.5	4.5	4.5	4.5	4.5	4.5	4.5	4.5		4.5	4.5	4.5
Lead/Lag	Lead	Lag	Lag	Lead	Lag	Lag	Lead			Lag	Lag	Lag
Lead-Lag Optimize?	Yes	Yes	Yes	Yes	Yes	Yes	Yes			Yes	Yes	Yes
Vehicle Extension (s)	3.0	3.0	3.0	3.0	3.0	3.0	3.0	3.0		3.0	3.0	3.0
Recall Mode	None	None	None	None	None	None	None	Min		Min	Min	Min
Walk Time (s)		7.0	7.0		7.0	7.0		7.0		7.0	7.0	7.0
Flash Dont Walk (s)		11.0	11.0		11.0	11.0		11.0		11.0	11.0	11.0
Pedestrian Calls (#/hr)		0	0		0	0		0		0	0	0
Act Effct Green (s)	31.9	29.4	29.4	30.9	27.3	27.3	15.9	15.9		9.1	9.1	9.1
Actuated g/C Ratio	0.53	0.48	0.48	0.51	0.45	0.45	0.26	0.26		0.15	0.15	0.15
v/c Ratio	0.32	0.75	0.18	0.15	0.64	0.08	0.26	0.29		0.17	0.28	0.23
Control Delay	8.5	20.1	2.6	7.0	17.6	0.4	23.6	12.6		31.9	32.1	3.7
Queue Delay	0.0	0.0	0.0	0.0	0.0	0.0	0.0	0.0		0.0	0.0	0.0
Total Delay	8.5	20.1	2.6	7.0	17.6	0.4	23.6	12.6		31.9	32.1	3.7
LOS	A	C	A	A	B	A	C	B		C	C	A
Approach Delay		15.8			15.1			16.5			20.3	
Approach LOS		B			B			B			C	

Intersection Summary

Area Type:	Other
Cycle Length:	90
Actuated Cycle Length:	60.7
Natural Cycle:	80
Control Type:	Actuated-Uncoordinated
Maximum v/c Ratio:	0.75
Intersection Signal Delay:	16.0
Intersection LOS:	B
Intersection Capacity Utilization:	66.4%
ICU Level of Service:	C
Analysis Period (min):	15

Splits and Phases: 14: Furrow Rd & Hwy 105

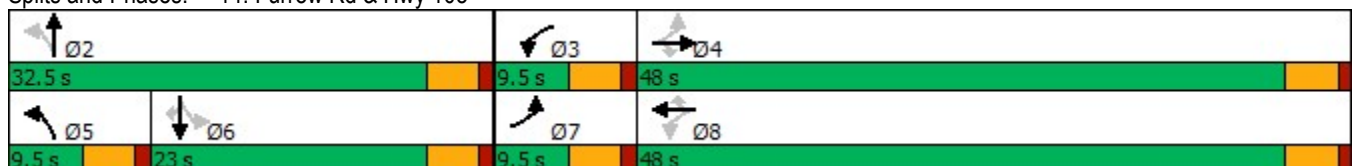

Intersection						
Int Delay, s/veh	2.5					
Movement	EBT	EBR	WBL	WBT	NBL	NBR
Lane Configurations						
Traffic Vol, veh/h	225	25	75	160	15	55
Future Vol, veh/h	225	25	75	160	15	55
Conflicting Peds, #/hr	0	0	0	0	0	0
Sign Control	Free	Free	Free	Free	Stop	Stop
RT Channelized	-	None	-	None	-	None
Storage Length	-	-	135	-	0	-
Veh in Median Storage, #	0	-	-	0	0	-
Grade, %	0	-	-	0	0	-
Peak Hour Factor	95	95	85	85	95	95
Heavy Vehicles, %	2	2	2	2	2	2
Mvmt Flow	237	26	88	188	16	58

Major/Minor	Major1	Major2	Minor1		
Conflicting Flow All	0	0	263	0	614 250
Stage 1	-	-	-	-	250 -
Stage 2	-	-	-	-	364 -
Critical Hdwy	-	-	4.12	-	6.42 6.22
Critical Hdwy Stg 1	-	-	-	-	5.42 -
Critical Hdwy Stg 2	-	-	-	-	5.42 -
Follow-up Hdwy	-	-	2.218	-	3.518 3.318
Pot Cap-1 Maneuver	-	-	1301	-	455 789
Stage 1	-	-	-	-	792 -
Stage 2	-	-	-	-	703 -
Platoon blocked, %	-	-	-	-	-
Mov Cap-1 Maneuver	-	-	1301	-	424 789
Mov Cap-2 Maneuver	-	-	-	-	424 -
Stage 1	-	-	-	-	792 -
Stage 2	-	-	-	-	655 -

Approach	EB	WB	NB
HCM Control Delay, s	0	2.5	11.1
HCM LOS			B

Minor Lane/Major Mvmt	NBLn1	EBT	EBR	WBL	WBT
Capacity (veh/h)	666	-	-	1301	-
HCM Lane V/C Ratio	0.111	-	-	0.068	-
HCM Control Delay (s)	11.1	-	-	8	-
HCM Lane LOS	B	-	-	A	-
HCM 95th %tile Q(veh)	0.4	-	-	0.2	-

Intersection												
Int Delay, s/veh	10.7											
Movement	EBL	EBT	EBR	WBL	WBT	WBR	NBL	NBT	NBR	SBL	SBT	SBR
Lane Configurations	↖	↗	↖	↖	↗	↖	↖	↗	↖	↖	↗	↖
Traffic Vol, veh/h	75	150	100	25	125	25	75	135	15	60	150	50
Future Vol, veh/h	75	150	100	25	125	25	75	135	15	60	150	50
Conflicting Peds, #/hr	0	0	0	0	0	0	0	0	0	0	0	0
Sign Control	Free	Free	Free	Free	Free	Free	Stop	Stop	Stop	Stop	Stop	Stop
RT Channelized	-	-	None	-	-	None	-	-	None	-	-	None
Storage Length	135	-	135	135	-	135	115	-	115	115	-	115
Veh in Median Storage, #	-	0	-	-	0	-	-	0	-	-	0	-
Grade, %	-	6	-	-	6	-	-	0	-	-	0	-
Peak Hour Factor	95	95	95	85	85	85	95	95	95	95	95	95
Heavy Vehicles, %	2	2	2	2	2	2	2	2	2	2	2	2
Mvmt Flow	79	158	105	29	147	29	79	142	16	63	158	53

Major/Minor	Major1			Major2			Minor1			Minor2		
Conflicting Flow All	176	0	0	263	0	0	641	550	158	653	626	147
Stage 1	-	-	-	-	-	-	316	316	-	205	205	-
Stage 2	-	-	-	-	-	-	325	234	-	448	421	-
Critical Hdwy	4.12	-	-	4.12	-	-	7.12	6.52	6.22	7.12	6.52	6.22
Critical Hdwy Stg 1	-	-	-	-	-	-	6.12	5.52	-	6.12	5.52	-
Critical Hdwy Stg 2	-	-	-	-	-	-	6.12	5.52	-	6.12	5.52	-
Follow-up Hdwy	2.218	-	-	2.218	-	-	3.518	4.018	3.318	3.518	4.018	3.318
Pot Cap-1 Maneuver	1400	-	-	1301	-	-	388	443	887	380	401	900
Stage 1	-	-	-	-	-	-	695	655	-	797	732	-
Stage 2	-	-	-	-	-	-	687	711	-	590	589	-
Platoon blocked, %	-	-	-	-	-	-	-	-	-	-	-	-
Mov Cap-1 Maneuver	1400	-	-	1301	-	-	230	409	887	257	370	900
Mov Cap-2 Maneuver	-	-	-	-	-	-	230	409	-	257	370	-
Stage 1	-	-	-	-	-	-	656	618	-	752	716	-
Stage 2	-	-	-	-	-	-	493	695	-	421	556	-

Approach	EB			WB			NB			SB		
HCM Control Delay, s	1.8			1.1			21.2			19.8		
HCM LOS							C			C		

Minor Lane/Major Mvmt	NBLn1	NBLn2	NBLn3	EBL	EBT	EBR	WBL	WBT	WBR	SBLn1	SBLn2	SBLn3
Capacity (veh/h)	230	409	887	1400	-	-	1301	-	-	257	370	900
HCM Lane V/C Ratio	0.343	0.347	0.018	0.056	-	-	0.023	-	-	0.246	0.427	0.058
HCM Control Delay (s)	28.6	18.4	9.1	7.7	-	-	7.8	-	-	23.5	21.8	9.2
HCM Lane LOS	D	C	A	A	-	-	A	-	-	C	C	A
HCM 95th %tile Q(veh)	1.5	1.5	0.1	0.2	-	-	0.1	-	-	0.9	2.1	0.2

Intersection						
Int Delay, s/veh	1					
Movement	EBL	EBT	WBT	WBR	SBL	SBR
Lane Configurations		↕	↕		↕	
Traffic Vol, veh/h	30	305	230	20	20	15
Future Vol, veh/h	30	305	230	20	20	15
Conflicting Peds, #/hr	0	0	0	0	0	0
Sign Control	Free	Free	Free	Free	Stop	Stop
RT Channelized	-	None	-	None	-	None
Storage Length	-	-	-	-	0	-
Veh in Median Storage, #	-	0	0	-	0	-
Grade, %	-	6	0	-	0	-
Peak Hour Factor	95	95	85	85	95	95
Heavy Vehicles, %	2	2	2	2	2	2
Mvmt Flow	32	321	271	24	21	16

Major/Minor	Major1	Major2	Minor2		
Conflicting Flow All	295	0	-	0	668 283
Stage 1	-	-	-	-	283 -
Stage 2	-	-	-	-	385 -
Critical Hdwy	4.12	-	-	-	6.42 6.22
Critical Hdwy Stg 1	-	-	-	-	5.42 -
Critical Hdwy Stg 2	-	-	-	-	5.42 -
Follow-up Hdwy	2.218	-	-	-	3.518 3.318
Pot Cap-1 Maneuver	1266	-	-	-	423 756
Stage 1	-	-	-	-	765 -
Stage 2	-	-	-	-	688 -
Platoon blocked, %		-	-	-	
Mov Cap-1 Maneuver	1266	-	-	-	410 756
Mov Cap-2 Maneuver	-	-	-	-	410 -
Stage 1	-	-	-	-	741 -
Stage 2	-	-	-	-	688 -

Approach	EB	WB	SB
HCM Control Delay, s	0.7	0	12.6
HCM LOS			B

Minor Lane/Major Mvmt	EBL	EBT	WBT	WBR	SBLn1
Capacity (veh/h)	1266	-	-	-	510
HCM Lane V/C Ratio	0.025	-	-	-	0.072
HCM Control Delay (s)	7.9	0	-	-	12.6
HCM Lane LOS	A	A	-	-	B
HCM 95th %tile Q(veh)	0.1	-	-	-	0.2

Intersection												
Int Delay, s/veh	21.4											
Movement	EBL	EBT	EBR	WBL	WBT	WBR	NBL	NBT	NBR	SBL	SBT	SBR
Lane Configurations	↖	↑	↗	↖	↑	↗	↖	↗		↖	↑	↗
Traffic Vol, veh/h	130	680	150	50	535	65	70	50	75	30	75	75
Future Vol, veh/h	130	680	150	50	535	65	70	50	75	30	75	75
Conflicting Peds, #/hr	0	0	0	0	0	0	0	0	0	0	0	0
Sign Control	Free	Free	Free	Free	Free	Free	Stop	Stop	Stop	Stop	Stop	Stop
RT Channelized	-	-	None	-	-	None	-	-	None	-	-	None
Storage Length	310	-	420	330	-	235	140	-	-	140	-	140
Veh in Median Storage, #	-	0	-	-	0	-	-	0	-	-	0	-
Grade, %	-	0	-	-	0	-	-	0	-	-	0	-
Peak Hour Factor	100	100	100	100	100	100	85	85	85	95	95	95
Heavy Vehicles, %	2	2	2	2	2	2	2	2	2	2	2	2
Mvmt Flow	130	680	150	50	535	65	82	59	88	32	79	79

Major/Minor	Major1			Major2			Minor1			Minor2		
Conflicting Flow All	600	0	0	830	0	0	1687	1640	680	1724	1725	535
Stage 1	-	-	-	-	-	-	940	940	-	635	635	-
Stage 2	-	-	-	-	-	-	747	700	-	1089	1090	-
Critical Hdwy	4.12	-	-	4.12	-	-	7.12	6.52	6.22	7.12	6.52	6.22
Critical Hdwy Stg 1	-	-	-	-	-	-	6.12	5.52	-	6.12	5.52	-
Critical Hdwy Stg 2	-	-	-	-	-	-	6.12	5.52	-	6.12	5.52	-
Follow-up Hdwy	2.218	-	-	2.218	-	-	3.518	4.018	3.318	3.518	4.018	3.318
Pot Cap-1 Maneuver	977	-	-	802	-	-	~ 74	100	451	70	89	545
Stage 1	-	-	-	-	-	-	316	342	-	467	472	-
Stage 2	-	-	-	-	-	-	405	441	-	261	291	-
Platoon blocked, %	-	-	-	-	-	-	-	-	-	-	-	-
Mov Cap-1 Maneuver	977	-	-	802	-	-	-	81	451	~ 20	~ 72	545
Mov Cap-2 Maneuver	-	-	-	-	-	-	-	81	-	~ 20	~ 72	-
Stage 1	-	-	-	-	-	-	274	297	-	405	443	-
Stage 2	-	-	-	-	-	-	267	414	-	146	252	-























Approach	EB	WB	NB	SB
HCM Control Delay, s	1.3	0.8		219.3
HCM LOS			-	F

Minor Lane/Major Mvmt	NBLn1	NBLn2	EBL	EBT	EBR	WBL	WBT	WBR	SBLn1	SBLn2	SBLn3
Capacity (veh/h)	-	160	977	-	-	802	-	-	20	72	545
HCM Lane V/C Ratio	-	0.919	0.133	-	-	0.062	-	-	1.579	1.096	0.145
HCM Control Delay (s)	-	107.5	9.2	-	-	9.8	-	-	\$ 695.9	235.3	12.7
HCM Lane LOS	-	F	A	-	-	A	-	-	F	F	B
HCM 95th %tile Q(veh)	-	6.7	0.5	-	-	0.2	-	-	4.2	5.9	0.5

Notes  
 ~: Volume exceeds capacity    \$: Delay exceeds 300s    +: Computation Not Defined    \*: All major volume in platoon

Lanes, Volumes, Timings  
14: Furrow Rd & Hwy 105

2040 Background + Site  
AM (Signal)

												
Lane Group	EBL	EBT	EBR	WBL	WBT	WBR	NBL	NBT	NBR	SBL	SBT	SBR
Lane Configurations												
Traffic Volume (vph)	55	290	76	52	810	25	129	75	52	35	50	155
Future Volume (vph)	55	290	76	52	810	25	129	75	52	35	50	155
Ideal Flow (vphpl)	1900	1900	1900	1900	1900	1900	1900	1900	1900	1900	1900	1900
Storage Length (ft)	310		420	330		235	140		0	135		135
Storage Lanes	1		1	1		1	1		0	1		1
Taper Length (ft)	125			155			105			140		
Lane Util. Factor	1.00	1.00	1.00	1.00	1.00	1.00	1.00	1.00	1.00	1.00	1.00	1.00
Frt			0.850			0.850		0.939				0.850
Flt Protected	0.950			0.950			0.950			0.950		
Satd. Flow (prot)	1770	1863	1583	1770	1863	1583	1770	1749	0	1770	1863	1583
Flt Permitted	0.129			0.550			0.466			0.662		
Satd. Flow (perm)	240	1863	1583	1025	1863	1583	868	1749	0	1233	1863	1583
Right Turn on Red			Yes			Yes			Yes			Yes
Satd. Flow (RTOR)			127			127		40				163
Link Speed (mph)		50			50			25				35
Link Distance (ft)		959			1048			712				530
Travel Time (s)		13.1			14.3			19.4				10.3
Peak Hour Factor	1.00	1.00	1.00	1.00	1.00	1.00	0.85	0.85	0.85	0.95	0.95	0.95
Adj. Flow (vph)	55	290	76	52	810	25	152	88	61	37	53	163
Shared Lane Traffic (%)												
Lane Group Flow (vph)	55	290	76	52	810	25	152	149	0	37	53	163
Enter Blocked Intersection	No	No	No	No	No	No	No	No	No	No	No	No
Lane Alignment	Left	Left	Right	Left	Left	Right	Left	Left	Right	Left	Left	Right
Median Width(ft)		12			12			12				12
Link Offset(ft)		0			0			0				0
Crosswalk Width(ft)		16			16			16				16
Two way Left Turn Lane												
Headway Factor	1.00	1.00	1.00	1.00	1.00	1.00	1.00	1.00	1.00	1.00	1.00	1.00
Turning Speed (mph)	15		9	15		9	15		9	15		9
Number of Detectors	1	2	1	1	2	1	1	2		1	2	1
Detector Template	Left	Thru	Right	Left	Thru	Right	Left	Thru		Left	Thru	Right
Leading Detector (ft)	20	100	20	20	100	20	20	100		20	100	20
Trailing Detector (ft)	0	0	0	0	0	0	0	0		0	0	0
Detector 1 Position(ft)	0	0	0	0	0	0	0	0		0	0	0
Detector 1 Size(ft)	20	6	20	20	6	20	20	6		20	6	20
Detector 1 Type	Cl+Ex	Cl+Ex	Cl+Ex	Cl+Ex	Cl+Ex	Cl+Ex	Cl+Ex	Cl+Ex		Cl+Ex	Cl+Ex	Cl+Ex
Detector 1 Channel												
Detector 1 Extend (s)	0.0	0.0	0.0	0.0	0.0	0.0	0.0	0.0		0.0	0.0	0.0
Detector 1 Queue (s)	0.0	0.0	0.0	0.0	0.0	0.0	0.0	0.0		0.0	0.0	0.0
Detector 1 Delay (s)	0.0	0.0	0.0	0.0	0.0	0.0	0.0	0.0		0.0	0.0	0.0
Detector 2 Position(ft)		94			94			94				94
Detector 2 Size(ft)		6			6			6				6
Detector 2 Type		Cl+Ex			Cl+Ex			Cl+Ex				Cl+Ex
Detector 2 Channel												
Detector 2 Extend (s)		0.0			0.0			0.0				0.0
Turn Type	pm+pt	NA	Perm	pm+pt	NA	Perm	pm+pt	NA		Perm	NA	Perm
Protected Phases	7	4		3	8		5	2				6
Permitted Phases	4		4	8		8	2			6		6

Lanes, Volumes, Timings  
14: Furrow Rd & Hwy 105

2040 Background + Site  
AM (Signal)

Lane Group	EBL	EBT	EBR	WBL	WBT	WBR	NBL	NBT	NBR	SBL	SBT	SBR
Detector Phase	7	4	4	3	8	8	5	2		6	6	6
Switch Phase												
Minimum Initial (s)	5.0	5.0	5.0	5.0	5.0	5.0	5.0	5.0		5.0	5.0	5.0
Minimum Split (s)	9.5	22.5	22.5	9.5	22.5	22.5	9.5	22.5		22.5	22.5	22.5
Total Split (s)	9.5	48.0	48.0	9.5	48.0	48.0	9.5	32.5		23.0	23.0	23.0
Total Split (%)	10.6%	53.3%	53.3%	10.6%	53.3%	53.3%	10.6%	36.1%		25.6%	25.6%	25.6%
Maximum Green (s)	5.0	43.5	43.5	5.0	43.5	43.5	5.0	28.0		18.5	18.5	18.5
Yellow Time (s)	3.5	3.5	3.5	3.5	3.5	3.5	3.5	3.5		3.5	3.5	3.5
All-Red Time (s)	1.0	1.0	1.0	1.0	1.0	1.0	1.0	1.0		1.0	1.0	1.0
Lost Time Adjust (s)	0.0	0.0	0.0	0.0	0.0	0.0	0.0	0.0		0.0	0.0	0.0
Total Lost Time (s)	4.5	4.5	4.5	4.5	4.5	4.5	4.5	4.5		4.5	4.5	4.5
Lead/Lag	Lead	Lag	Lag	Lead	Lag	Lag	Lead			Lag	Lag	Lag
Lead-Lag Optimize?	Yes	Yes	Yes	Yes	Yes	Yes	Yes			Yes	Yes	Yes
Vehicle Extension (s)	3.0	3.0	3.0	3.0	3.0	3.0	3.0	3.0		3.0	3.0	3.0
Recall Mode	None	None	None	None	None	None	None	Min		Min	Min	Min
Walk Time (s)		7.0	7.0		7.0	7.0		7.0		7.0	7.0	7.0
Flash Dont Walk (s)		11.0	11.0		11.0	11.0		11.0		11.0	11.0	11.0
Pedestrian Calls (#/hr)		0	0		0	0		0		0	0	0
Act Effct Green (s)	39.1	36.5	36.5	39.1	36.5	36.5	18.0	18.0		8.0	8.0	8.0
Actuated g/C Ratio	0.57	0.53	0.53	0.57	0.53	0.53	0.26	0.26		0.12	0.12	0.12
v/c Ratio	0.22	0.29	0.08	0.08	0.82	0.03	0.52	0.31		0.26	0.25	0.50
Control Delay	7.4	10.7	0.8	5.6	23.0	0.0	31.8	20.4		36.7	34.6	11.9
Queue Delay	0.0	0.0	0.0	0.0	0.0	0.0	0.0	0.0		0.0	0.0	0.0
Total Delay	7.4	10.7	0.8	5.6	23.0	0.0	31.8	20.4		36.7	34.6	11.9
LOS	A	B	A	A	C	A	C	C		D	C	B
Approach Delay		8.4			21.4			26.2			20.3	
Approach LOS		A			C			C			C	

Intersection Summary

Area Type:	Other
Cycle Length:	90
Actuated Cycle Length:	68.9
Natural Cycle:	90
Control Type:	Actuated-Uncoordinated
Maximum v/c Ratio:	0.82
Intersection Signal Delay:	19.1
Intersection LOS:	B
Intersection Capacity Utilization:	70.6%
ICU Level of Service:	C
Analysis Period (min):	15

Splits and Phases: 14: Furrow Rd & Hwy 105

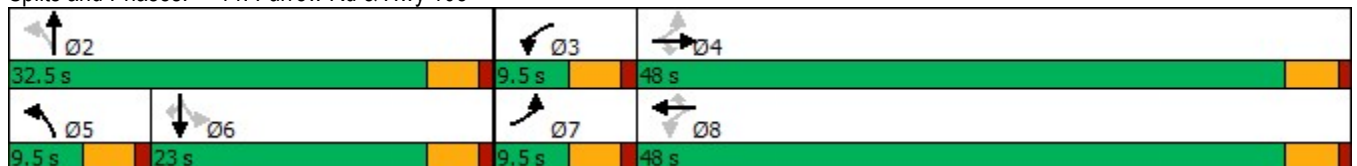



Intersection												
Int Delay, s/veh	0.5											
Movement	EBL	EBT	EBR	WBL	WBT	WBR	NBL	NBT	NBR	SBL	SBT	SBR
Lane Configurations		↕			↕			↕			↕	
Traffic Vol, veh/h	2	0	6	7	0	2	2	277	2	1	176	1
Future Vol, veh/h	2	0	6	7	0	2	2	277	2	1	176	1
Conflicting Peds, #/hr	0	0	0	0	0	0	0	0	0	0	0	0
Sign Control	Stop	Stop	Stop	Stop	Stop	Stop	Free	Free	Free	Free	Free	Free
RT Channelized	-	-	None	-	-	None	-	-	None	-	-	None
Storage Length	-	-	-	-	-	-	-	-	-	-	-	-
Veh in Median Storage, #	-	0	-	-	0	-	-	0	-	-	0	-
Grade, %	-	0	-	-	0	-	-	0	-	-	0	-
Peak Hour Factor	95	95	95	95	95	95	95	95	95	95	95	95
Heavy Vehicles, %	2	2	2	2	2	2	2	2	2	2	2	2
Mvmt Flow	2	0	6	7	0	2	2	292	2	1	185	1

Major/Minor	Minor2		Minor1		Major1		Major2					
Conflicting Flow All	486	486	186	488	485	293	186	0	0	294	0	0
Stage 1	188	188	-	297	297	-	-	-	-	-	-	-
Stage 2	298	298	-	191	188	-	-	-	-	-	-	-
Critical Hdwy	7.12	6.52	6.22	7.12	6.52	6.22	4.12	-	-	4.12	-	-
Critical Hdwy Stg 1	6.12	5.52	-	6.12	5.52	-	-	-	-	-	-	-
Critical Hdwy Stg 2	6.12	5.52	-	6.12	5.52	-	-	-	-	-	-	-
Follow-up Hdwy	3.518	4.018	3.318	3.518	4.018	3.318	2.218	-	-	2.218	-	-
Pot Cap-1 Maneuver	492	481	856	490	482	746	1388	-	-	1268	-	-
Stage 1	814	745	-	712	668	-	-	-	-	-	-	-
Stage 2	711	667	-	811	745	-	-	-	-	-	-	-
Platoon blocked, %								-	-	-	-	-
Mov Cap-1 Maneuver	490	480	856	485	481	746	1388	-	-	1268	-	-
Mov Cap-2 Maneuver	490	480	-	485	481	-	-	-	-	-	-	-
Stage 1	812	744	-	711	667	-	-	-	-	-	-	-
Stage 2	708	666	-	804	744	-	-	-	-	-	-	-

Approach	EB		WB		NB		SB	
HCM Control Delay, s	10.1		12		0.1		0	
HCM LOS	B		B					

Minor Lane/Major Mvmt	NBL	NBT	NBR	EBLn1	WBLn1	SBL	SBT	SBR
Capacity (veh/h)	1388	-	-	721	526	1268	-	-
HCM Lane V/C Ratio	0.002	-	-	0.012	0.018	0.001	-	-
HCM Control Delay (s)	7.6	0	-	10.1	12	7.8	0	-
HCM Lane LOS	A	A	-	B	B	A	A	-
HCM 95th %tile Q(veh)	0	-	-	0	0.1	0	-	-

Intersection												
Int Delay, s/veh	2.7											
Movement	EBL	EBT	EBR	WBL	WBT	WBR	NBL	NBT	NBR	SBL	SBT	SBR
Lane Configurations		↕		↕	↕			↕			↕	
Traffic Vol, veh/h	3	152	10	60	191	1	20	0	50	2	1	9
Future Vol, veh/h	3	152	10	60	191	1	20	0	50	2	1	9
Conflicting Peds, #/hr	0	0	0	0	0	0	0	0	0	0	0	0
Sign Control	Free	Free	Free	Free	Free	Free	Stop	Stop	Stop	Stop	Stop	Stop
RT Channelized	-	-	None	-	-	None	-	-	None	-	-	None
Storage Length	-	-	-	135	-	-	-	-	-	-	-	-
Veh in Median Storage, #	-	0	-	-	0	-	-	0	-	-	0	-
Grade, %	-	0	-	-	0	-	-	0	-	-	0	-
Peak Hour Factor	92	95	95	85	85	92	95	92	95	92	92	92
Heavy Vehicles, %	2	2	2	2	2	2	2	2	2	2	2	2
Mvmt Flow	3	160	11	71	225	1	21	0	53	2	1	10

Major/Minor	Major1			Major2			Minor1			Minor2		
Conflicting Flow All	226	0	0	171	0	0	545	540	166	566	545	226
Stage 1	-	-	-	-	-	-	172	172	-	368	368	-
Stage 2	-	-	-	-	-	-	373	368	-	198	177	-
Critical Hdwy	4.12	-	-	4.12	-	-	7.12	6.52	6.22	7.12	6.52	6.22
Critical Hdwy Stg 1	-	-	-	-	-	-	6.12	5.52	-	6.12	5.52	-
Critical Hdwy Stg 2	-	-	-	-	-	-	6.12	5.52	-	6.12	5.52	-
Follow-up Hdwy	2.218	-	-	2.218	-	-	3.518	4.018	3.318	3.518	4.018	3.318
Pot Cap-1 Maneuver	1342	-	-	1406	-	-	449	449	878	435	446	813
Stage 1	-	-	-	-	-	-	830	756	-	652	621	-
Stage 2	-	-	-	-	-	-	648	621	-	804	753	-
Platoon blocked, %	-	-	-	-	-	-	-	-	-	-	-	-
Mov Cap-1 Maneuver	1342	-	-	1406	-	-	425	426	878	392	423	813
Mov Cap-2 Maneuver	-	-	-	-	-	-	425	426	-	392	423	-
Stage 1	-	-	-	-	-	-	828	754	-	651	590	-
Stage 2	-	-	-	-	-	-	607	590	-	754	751	-

Approach	EB			WB			NB			SB		
HCM Control Delay, s	0.1			1.8			11			10.7		
HCM LOS							B			B		

Minor Lane/Major Mvmt	NBLn1	EBL	EBT	EBR	WBL	WBT	WBR	SBLn1
Capacity (veh/h)	673	1342	-	-	1406	-	-	647
HCM Lane V/C Ratio	0.109	0.002	-	-	0.05	-	-	0.02
HCM Control Delay (s)	11	7.7	0	-	7.7	-	-	10.7
HCM Lane LOS	B	A	A	-	A	-	-	B
HCM 95th %tile Q(veh)	0.4	0	-	-	0.2	-	-	0.1

Intersection												
Int Delay, s/veh	9.2											
Movement	EBL	EBT	EBR	WBL	WBT	WBR	NBL	NBT	NBR	SBL	SBT	SBR
Lane Configurations	↖	↑	↗	↖	↑	↗	↖	↑	↗	↖	↑	↗
Traffic Vol, veh/h	78	102	50	10	157	53	100	151	25	28	76	85
Future Vol, veh/h	78	102	50	10	157	53	100	151	25	28	76	85
Conflicting Peds, #/hr	0	0	0	0	0	0	0	0	0	0	0	0
Sign Control	Free	Free	Free	Free	Free	Free	Stop	Stop	Stop	Stop	Stop	Stop
RT Channelized	-	-	None	-	-	None	-	-	None	-	-	None
Storage Length	135	-	135	135	-	135	115	-	115	115	-	115
Veh in Median Storage, #	-	0	-	-	0	-	-	0	-	-	0	-
Grade, %	-	6	-	-	6	-	-	0	-	-	0	-
Peak Hour Factor	95	95	95	85	85	85	95	95	95	95	95	95
Heavy Vehicles, %	2	2	2	2	2	2	2	2	2	2	2	2
Mvmt Flow	82	107	53	12	185	62	105	159	26	29	80	89

Major/Minor	Major1			Major2			Minor1			Minor2		
Conflicting Flow All	247	0	0	160	0	0	596	542	107	599	533	185
Stage 1	-	-	-	-	-	-	271	271	-	209	209	-
Stage 2	-	-	-	-	-	-	325	271	-	390	324	-
Critical Hdwy	4.12	-	-	4.12	-	-	7.12	6.52	6.22	7.12	6.52	6.22
Critical Hdwy Stg 1	-	-	-	-	-	-	6.12	5.52	-	6.12	5.52	-
Critical Hdwy Stg 2	-	-	-	-	-	-	6.12	5.52	-	6.12	5.52	-
Follow-up Hdwy	2.218	-	-	2.218	-	-	3.518	4.018	3.318	3.518	4.018	3.318
Pot Cap-1 Maneuver	1319	-	-	1419	-	-	415	447	947	413	453	857
Stage 1	-	-	-	-	-	-	735	685	-	793	729	-
Stage 2	-	-	-	-	-	-	687	685	-	634	650	-
Platoon blocked, %	-	-	-	-	-	-	-	-	-	-	-	-
Mov Cap-1 Maneuver	1319	-	-	1419	-	-	301	416	947	268	421	857
Mov Cap-2 Maneuver	-	-	-	-	-	-	301	416	-	268	421	-
Stage 1	-	-	-	-	-	-	689	643	-	744	723	-
Stage 2	-	-	-	-	-	-	543	680	-	435	610	-

Approach	EB			WB			NB			SB		
HCM Control Delay, s	2.7			0.3			19.6			13.6		
HCM LOS							C			B		

Minor Lane/Major Mvmt	NBLn1	NBLn2	NBLn3	EBL	EBT	EBR	WBL	WBT	WBR	SBLn1	SBLn2	SBLn3
Capacity (veh/h)	301	416	947	1319	-	-	1419	-	-	268	421	857
HCM Lane V/C Ratio	0.35	0.382	0.028	0.062	-	-	0.008	-	-	0.11	0.19	0.104
HCM Control Delay (s)	23.3	18.9	8.9	7.9	-	-	7.6	-	-	20.1	15.5	9.7
HCM Lane LOS	C	C	A	A	-	-	A	-	-	C	C	A
HCM 95th %tile Q(veh)	1.5	1.8	0.1	0.2	-	-	0	-	-	0.4	0.7	0.3

Intersection						
Int Delay, s/veh	0.7					
Movement	EBL	EBT	WBT	WBR	SBL	SBR
Lane Configurations		↕	↕		↕	
Traffic Vol, veh/h	5	215	320	15	15	20
Future Vol, veh/h	5	215	320	15	15	20
Conflicting Peds, #/hr	0	0	0	0	0	0
Sign Control	Free	Free	Free	Free	Stop	Stop
RT Channelized	-	None	-	None	-	None
Storage Length	-	-	-	-	0	-
Veh in Median Storage, #	-	0	0	-	0	-
Grade, %	-	6	0	-	0	-
Peak Hour Factor	95	95	85	85	95	95
Heavy Vehicles, %	2	2	2	2	2	2
Mvmt Flow	5	226	376	18	16	21

Major/Minor	Major1	Major2	Minor2		
Conflicting Flow All	394	0	-	0	621 385
Stage 1	-	-	-	-	385 -
Stage 2	-	-	-	-	236 -
Critical Hdwy	4.12	-	-	-	6.42 6.22
Critical Hdwy Stg 1	-	-	-	-	5.42 -
Critical Hdwy Stg 2	-	-	-	-	5.42 -
Follow-up Hdwy	2.218	-	-	-	3.518 3.318
Pot Cap-1 Maneuver	1165	-	-	-	451 663
Stage 1	-	-	-	-	688 -
Stage 2	-	-	-	-	803 -
Platoon blocked, %		-	-	-	
Mov Cap-1 Maneuver	1165	-	-	-	449 663
Mov Cap-2 Maneuver	-	-	-	-	449 -
Stage 1	-	-	-	-	685 -
Stage 2	-	-	-	-	803 -

Approach	EB	WB	SB
HCM Control Delay, s	0.2	0	12
HCM LOS			B

Minor Lane/Major Mvmt	EBL	EBT	WBT	WBR	SBLn1
Capacity (veh/h)	1165	-	-	-	551
HCM Lane V/C Ratio	0.005	-	-	-	0.067
HCM Control Delay (s)	8.1	0	-	-	12
HCM Lane LOS	A	A	-	-	B
HCM 95th %tile Q(veh)	0	-	-	-	0.2

Intersection												
Int Delay, s/veh	136.1											
Movement	EBL	EBT	EBR	WBL	WBT	WBR	NBL	NBT	NBR	SBL	SBT	SBR
Lane Configurations	↖	↗	↖	↖	↗	↖	↖	↗		↖	↗	↖
Traffic Vol, veh/h	55	290	76	52	810	25	129	75	52	35	50	155
Future Vol, veh/h	55	290	76	52	810	25	129	75	52	35	50	155
Conflicting Peds, #/hr	0	0	0	0	0	0	0	0	0	0	0	0
Sign Control	Free	Free	Free	Free	Free	Free	Stop	Stop	Stop	Stop	Stop	Stop
RT Channelized	-	-	None	-	-	None	-	-	None	-	-	None
Storage Length	310	-	420	330	-	235	140	-	-	135	-	135
Veh in Median Storage, #	-	0	-	-	0	-	-	0	-	-	0	-
Grade, %	-	0	-	-	0	-	-	0	-	-	0	-
Peak Hour Factor	100	100	100	100	100	100	85	85	85	95	95	95
Heavy Vehicles, %	2	2	2	2	2	2	2	2	2	2	2	2
Mvmt Flow	55	290	76	52	810	25	152	88	61	37	53	163

Major/Minor	Major1		Major2		Minor1			Minor2				
Conflicting Flow All	835	0	0	366	0	0	1435	1339	290	1427	1390	810
Stage 1	-	-	-	-	-	-	400	400	-	914	914	-
Stage 2	-	-	-	-	-	-	1035	939	-	513	476	-
Critical Hdwy	4.12	-	-	4.12	-	-	7.12	6.52	6.22	7.12	6.52	6.22
Critical Hdwy Stg 1	-	-	-	-	-	-	6.12	5.52	-	6.12	5.52	-
Critical Hdwy Stg 2	-	-	-	-	-	-	6.12	5.52	-	6.12	5.52	-
Follow-up Hdwy	2.218	-	-	2.218	-	-	3.518	4.018	3.318	3.518	4.018	3.318
Pot Cap-1 Maneuver	798	-	-	1193	-	-	~ 111	153	749	113	142	380
Stage 1	-	-	-	-	-	-	626	602	-	327	352	-
Stage 2	-	-	-	-	-	-	280	343	-	544	557	-
Platoon blocked, %	-	-	-	-	-	-	-	-	-	-	-	-
Mov Cap-1 Maneuver	798	-	-	1193	-	-	~ 39	136	749	46	126	380
Mov Cap-2 Maneuver	-	-	-	-	-	-	~ 39	136	-	46	126	-
Stage 1	-	-	-	-	-	-	583	560	-	304	337	-
Stage 2	-	-	-	-	-	-	~ 129	328	-	392	519	-























Approach	EB	WB	NB	SB
HCM Control Delay, s	1.3	0.5	\$ 791.4	55.8
HCM LOS			F	F

Minor Lane/Major Mvmt	NBLn1	NBLn2	EBL	EBT	EBR	WBL	WBT	WBR	SBLn1	SBLn2	SBLn3
Capacity (veh/h)	39	205	798	-	-	1193	-	-	46	126	380
HCM Lane V/C Ratio	3.891	0.729	0.069	-	-	0.044	-	-	0.801	0.418	0.429
HCM Control Delay (s)	\$ 1512.6	58.9	9.8	-	-	8.2	-	-	212.3	52.7	21.4
HCM Lane LOS	F	F	A	-	-	A	-	-	F	F	C
HCM 95th %tile Q(veh)	17.4	4.8	0.2	-	-	0.1	-	-	3.2	1.8	2.1

Notes  
 ~: Volume exceeds capacity    \$: Delay exceeds 300s    +: Computation Not Defined    \*: All major volume in platoon













Lanes, Volumes, Timings  
14: Furrow Rd & Hwy 105

2040 Background + Site  
PM (Signal)

												
Lane Group	EBL	EBT	EBR	WBL	WBT	WBR	NBL	NBT	NBR	SBL	SBT	SBR
Lane Configurations												
Traffic Volume (vph)	130	680	156	53	535	65	72	50	78	30	75	75
Future Volume (vph)	130	680	156	53	535	65	72	50	78	30	75	75
Ideal Flow (vphpl)	1900	1900	1900	1900	1900	1900	1900	1900	1900	1900	1900	1900
Storage Length (ft)	310		420	330		235	135		0	135		135
Storage Lanes	1		1	1		1	1		0	1		1
Taper Length (ft)	125			155			105			140		
Lane Util. Factor	1.00	1.00	1.00	1.00	1.00	1.00	1.00	1.00	1.00	1.00	1.00	1.00
Frt			0.850			0.850		0.909				0.850
Flt Protected	0.950			0.950			0.950			0.950		
Satd. Flow (prot)	1770	1863	1583	1770	1863	1583	1770	1693	0	1770	1863	1583
Flt Permitted	0.237			0.217			0.472			0.661		
Satd. Flow (perm)	441	1863	1583	404	1863	1583	879	1693	0	1231	1863	1583
Right Turn on Red			Yes			Yes			Yes			Yes
Satd. Flow (RTOR)			156			127		91				127
Link Speed (mph)		50			50			25				35
Link Distance (ft)		959			1048			712				530
Travel Time (s)		13.1			14.3			19.4				10.3
Peak Hour Factor	1.00	1.00	1.00	0.95	0.95	0.95	0.85	0.85	0.85	0.95	0.95	0.95
Adj. Flow (vph)	130	680	156	56	563	68	85	59	92	32	79	79
Shared Lane Traffic (%)												
Lane Group Flow (vph)	130	680	156	56	563	68	85	151	0	32	79	79
Enter Blocked Intersection	No	No	No	No	No	No	No	No	No	No	No	No
Lane Alignment	Left	Left	Right	Left	Left	Right	Left	Left	Right	Left	Left	Right
Median Width(ft)		12			12			12				12
Link Offset(ft)		0			0			0				0
Crosswalk Width(ft)		16			16			16				16
Two way Left Turn Lane												
Headway Factor	1.00	1.00	1.00	1.00	1.00	1.00	1.00	1.00	1.00	1.00	1.00	1.00
Turning Speed (mph)	15		9	15		9	15		9	15		9
Number of Detectors	1	2	1	1	2	1	1	2		1	2	1
Detector Template	Left	Thru	Right	Left	Thru	Right	Left	Thru		Left	Thru	Right
Leading Detector (ft)	20	100	20	20	100	20	20	100		20	100	20
Trailing Detector (ft)	0	0	0	0	0	0	0	0		0	0	0
Detector 1 Position(ft)	0	0	0	0	0	0	0	0		0	0	0
Detector 1 Size(ft)	20	6	20	20	6	20	20	6		20	6	20
Detector 1 Type	Cl+Ex	Cl+Ex	Cl+Ex	Cl+Ex	Cl+Ex	Cl+Ex	Cl+Ex	Cl+Ex		Cl+Ex	Cl+Ex	Cl+Ex
Detector 1 Channel												
Detector 1 Extend (s)	0.0	0.0	0.0	0.0	0.0	0.0	0.0	0.0		0.0	0.0	0.0
Detector 1 Queue (s)	0.0	0.0	0.0	0.0	0.0	0.0	0.0	0.0		0.0	0.0	0.0
Detector 1 Delay (s)	0.0	0.0	0.0	0.0	0.0	0.0	0.0	0.0		0.0	0.0	0.0
Detector 2 Position(ft)		94			94			94				94
Detector 2 Size(ft)		6			6			6				6
Detector 2 Type		Cl+Ex			Cl+Ex			Cl+Ex				Cl+Ex
Detector 2 Channel												
Detector 2 Extend (s)		0.0			0.0			0.0				0.0
Turn Type	pm+pt	NA	Perm	pm+pt	NA	Perm	pm+pt	NA		Perm	NA	Perm
Protected Phases	7	4		3	8		5	2			6	
Permitted Phases	4		4	8		8	2			6		6

Lanes, Volumes, Timings  
14: Furrow Rd & Hwy 105

2040 Background + Site  
PM (Signal)

												
Lane Group	EBL	EBT	EBR	WBL	WBT	WBR	NBL	NBT	NBR	SBL	SBT	SBR
Detector Phase	7	4	4	3	8	8	5	2		6	6	6
Switch Phase												
Minimum Initial (s)	5.0	5.0	5.0	5.0	5.0	5.0	5.0	5.0		5.0	5.0	5.0
Minimum Split (s)	9.5	22.5	22.5	9.5	22.5	22.5	9.5	22.5		22.5	22.5	22.5
Total Split (s)	11.7	48.0	48.0	9.5	45.8	45.8	9.5	32.5		23.0	23.0	23.0
Total Split (%)	13.0%	53.3%	53.3%	10.6%	50.9%	50.9%	10.6%	36.1%		25.6%	25.6%	25.6%
Maximum Green (s)	7.2	43.5	43.5	5.0	41.3	41.3	5.0	28.0		18.5	18.5	18.5
Yellow Time (s)	3.5	3.5	3.5	3.5	3.5	3.5	3.5	3.5		3.5	3.5	3.5
All-Red Time (s)	1.0	1.0	1.0	1.0	1.0	1.0	1.0	1.0		1.0	1.0	1.0
Lost Time Adjust (s)	0.0	0.0	0.0	0.0	0.0	0.0	0.0	0.0		0.0	0.0	0.0
Total Lost Time (s)	4.5	4.5	4.5	4.5	4.5	4.5	4.5	4.5		4.5	4.5	4.5
Lead/Lag	Lead	Lag	Lag	Lead	Lag	Lag	Lead			Lag	Lag	Lag
Lead-Lag Optimize?	Yes	Yes	Yes	Yes	Yes	Yes	Yes			Yes	Yes	Yes
Vehicle Extension (s)	3.0	3.0	3.0	3.0	3.0	3.0	3.0	3.0		3.0	3.0	3.0
Recall Mode	None	None	None	None	None	None	None	Min		Min	Min	Min
Walk Time (s)		7.0	7.0		7.0	7.0		7.0		7.0	7.0	7.0
Flash Dont Walk (s)		11.0	11.0		11.0	11.0		11.0		11.0	11.0	11.0
Pedestrian Calls (#/hr)		0	0		0	0		0		0	0	0
Act Effct Green (s)	34.1	30.5	30.5	30.4	26.8	26.8	15.9	15.9		9.1	9.1	9.1
Actuated g/C Ratio	0.55	0.49	0.49	0.49	0.43	0.43	0.26	0.26		0.15	0.15	0.15
v/c Ratio	0.31	0.74	0.18	0.17	0.70	0.09	0.27	0.30		0.18	0.29	0.23
Control Delay	8.1	19.5	2.6	7.3	20.5	0.6	24.0	12.5		32.1	32.3	3.8
Queue Delay	0.0	0.0	0.0	0.0	0.0	0.0	0.0	0.0		0.0	0.0	0.0
Total Delay	8.1	19.5	2.6	7.3	20.5	0.6	24.0	12.5		32.1	32.3	3.8
LOS	A	B	A	A	C	A	C	B		C	C	A
Approach Delay		15.2			17.5			16.6			20.4	
Approach LOS		B			B			B			C	

Intersection Summary

Area Type:	Other
Cycle Length:	90
Actuated Cycle Length:	61.7
Natural Cycle:	80
Control Type:	Actuated-Uncoordinated
Maximum v/c Ratio:	0.74
Intersection Signal Delay:	16.6
Intersection LOS:	B
Intersection Capacity Utilization:	66.5%
ICU Level of Service:	C
Analysis Period (min):	15

Splits and Phases: 14: Furrow Rd & Hwy 105

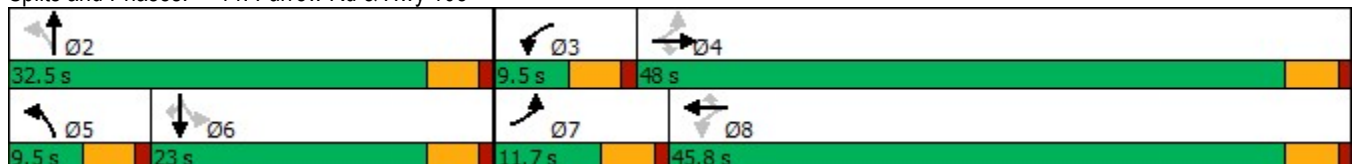

Intersection												
Int Delay, s/veh	0.4											
Movement	EBL	EBT	EBR	WBL	WBT	WBR	NBL	NBT	NBR	SBL	SBT	SBR
Lane Configurations		↕			↕			↕			↕	
Traffic Vol, veh/h	1	0	4	4	0	2	6	236	6	3	263	3
Future Vol, veh/h	1	0	4	4	0	2	6	236	6	3	263	3
Conflicting Peds, #/hr	0	0	0	0	0	0	0	0	0	0	0	0
Sign Control	Stop	Stop	Stop	Stop	Stop	Stop	Free	Free	Free	Free	Free	Free
RT Channelized	-	-	None	-	-	None	-	-	None	-	-	None
Storage Length	-	-	-	-	-	-	-	-	-	-	-	-
Veh in Median Storage, #	-	0	-	-	0	-	-	0	-	-	0	-
Grade, %	-	0	-	-	0	-	-	0	-	-	0	-
Peak Hour Factor	95	95	95	95	95	95	95	95	95	95	95	95
Heavy Vehicles, %	2	2	2	2	2	2	2	2	2	2	2	2
Mvmt Flow	1	0	4	4	0	2	6	248	6	3	277	3

Major/Minor	Minor2		Minor1		Major1		Major2					
Conflicting Flow All	549	551	279	550	549	251	280	0	0	254	0	0
Stage 1	285	285	-	263	263	-	-	-	-	-	-	-
Stage 2	264	266	-	287	286	-	-	-	-	-	-	-
Critical Hdwy	7.12	6.52	6.22	7.12	6.52	6.22	4.12	-	-	4.12	-	-
Critical Hdwy Stg 1	6.12	5.52	-	6.12	5.52	-	-	-	-	-	-	-
Critical Hdwy Stg 2	6.12	5.52	-	6.12	5.52	-	-	-	-	-	-	-
Follow-up Hdwy	3.518	4.018	3.318	3.518	4.018	3.318	2.218	-	-	2.218	-	-
Pot Cap-1 Maneuver	446	442	760	446	443	788	1283	-	-	1311	-	-
Stage 1	722	676	-	742	691	-	-	-	-	-	-	-
Stage 2	741	689	-	720	675	-	-	-	-	-	-	-
Platoon blocked, %								-	-	-	-	-
Mov Cap-1 Maneuver	442	438	760	441	439	788	1283	-	-	1311	-	-
Mov Cap-2 Maneuver	442	438	-	441	439	-	-	-	-	-	-	-
Stage 1	718	674	-	738	688	-	-	-	-	-	-	-
Stage 2	735	686	-	714	673	-	-	-	-	-	-	-

Approach	EB		WB		NB		SB	
HCM Control Delay, s	10.5		12		0.2		0.1	
HCM LOS	B		B					

Minor Lane/Major Mvmt	NBL	NBT	NBR	EBLn1	WBLn1	SBL	SBT	SBR
Capacity (veh/h)	1283	-	-	664	517	1311	-	-
HCM Lane V/C Ratio	0.005	-	-	0.008	0.012	0.002	-	-
HCM Control Delay (s)	7.8	0	-	10.5	12	7.8	0	-
HCM Lane LOS	A	A	-	B	B	A	A	-
HCM 95th %tile Q(veh)	0	-	-	0	0	0	-	-



Intersection												
Int Delay, s/veh	2.8											
Movement	EBL	EBT	EBR	WBL	WBT	WBR	NBL	NBT	NBR	SBL	SBT	SBR
Lane Configurations		↕		↕	↕			↕			↕	
Traffic Vol, veh/h	12	226	25	75	162	2	15	1	55	1	1	6
Future Vol, veh/h	12	226	25	75	162	2	15	1	55	1	1	6
Conflicting Peds, #/hr	0	0	0	0	0	0	0	0	0	0	0	0
Sign Control	Free	Free	Free	Free	Free	Free	Stop	Stop	Stop	Stop	Stop	Stop
RT Channelized	-	-	None	-	-	None	-	-	None	-	-	None
Storage Length	-	-	-	135	-	-	-	-	-	-	-	-
Veh in Median Storage, #	-	0	-	-	0	-	-	0	-	-	0	-
Grade, %	-	0	-	-	0	-	-	0	-	-	0	-
Peak Hour Factor	92	95	95	85	85	92	95	92	95	92	92	92
Heavy Vehicles, %	2	2	2	2	2	2	2	2	2	2	2	2
Mvmt Flow	13	238	26	88	191	2	16	1	58	1	1	7

Major/Minor	Major1			Major2			Minor1			Minor2		
Conflicting Flow All	193	0	0	264	0	0	649	646	251	675	658	192
Stage 1	-	-	-	-	-	-	277	277	-	368	368	-
Stage 2	-	-	-	-	-	-	372	369	-	307	290	-
Critical Hdwy	4.12	-	-	4.12	-	-	7.12	6.52	6.22	7.12	6.52	6.22
Critical Hdwy Stg 1	-	-	-	-	-	-	6.12	5.52	-	6.12	5.52	-
Critical Hdwy Stg 2	-	-	-	-	-	-	6.12	5.52	-	6.12	5.52	-
Follow-up Hdwy	2.218	-	-	2.218	-	-	3.518	4.018	3.318	3.518	4.018	3.318
Pot Cap-1 Maneuver	1380	-	-	1300	-	-	383	390	788	368	384	850
Stage 1	-	-	-	-	-	-	729	681	-	652	621	-
Stage 2	-	-	-	-	-	-	648	621	-	703	672	-
Platoon blocked, %	-	-	-	-	-	-	-	-	-	-	-	-
Mov Cap-1 Maneuver	1380	-	-	1300	-	-	357	360	788	320	354	850
Mov Cap-2 Maneuver	-	-	-	-	-	-	357	360	-	320	354	-
Stage 1	-	-	-	-	-	-	721	674	-	645	579	-
Stage 2	-	-	-	-	-	-	598	579	-	643	665	-

Approach	EB			WB			NB			SB		
HCM Control Delay, s	0.4			2.5			11.6			10.9		
HCM LOS							B			B		

Minor Lane/Major Mvmt	NBLn1	EBL	EBT	EBR	WBL	WBT	WBR	SBLn1
Capacity (veh/h)	619	1380	-	-	1300	-	-	615
HCM Lane V/C Ratio	0.121	0.009	-	-	0.068	-	-	0.014
HCM Control Delay (s)	11.6	7.6	0	-	8	-	-	10.9
HCM Lane LOS	B	A	A	-	A	-	-	B
HCM 95th %tile Q(veh)	0.4	0	-	-	0.2	-	-	0

Intersection												
Int Delay, s/veh	11.3											
Movement	EBL	EBT	EBR	WBL	WBT	WBR	NBL	NBT	NBR	SBL	SBT	SBR
Lane Configurations	↖	↗	↖	↖	↗	↖	↖	↗	↖	↖	↗	↖
Traffic Vol, veh/h	83	157	100	25	129	29	75	136	15	65	151	56
Future Vol, veh/h	83	157	100	25	129	29	75	136	15	65	151	56
Conflicting Peds, #/hr	0	0	0	0	0	0	0	0	0	0	0	0
Sign Control	Free	Free	Free	Free	Free	Free	Stop	Stop	Stop	Stop	Stop	Stop
RT Channelized	-	-	None	-	-	None	-	-	None	-	-	None
Storage Length	135	-	135	135	-	135	115	-	115	115	-	115
Veh in Median Storage, #	-	0	-	-	0	-	-	0	-	-	0	-
Grade, %	-	6	-	-	6	-	-	0	-	-	0	-
Peak Hour Factor	95	95	95	85	85	85	95	95	95	95	95	95
Heavy Vehicles, %	2	2	2	2	2	2	2	2	2	2	2	2
Mvmt Flow	87	165	105	29	152	34	79	143	16	68	159	59

Major/Minor	Major1			Major2			Minor1			Minor2		
Conflicting Flow All	186	0	0	270	0	0	675	583	165	681	654	152
Stage 1	-	-	-	-	-	-	339	339	-	210	210	-
Stage 2	-	-	-	-	-	-	336	244	-	471	444	-
Critical Hdwy	4.12	-	-	4.12	-	-	7.12	6.52	6.22	7.12	6.52	6.22
Critical Hdwy Stg 1	-	-	-	-	-	-	6.12	5.52	-	6.12	5.52	-
Critical Hdwy Stg 2	-	-	-	-	-	-	6.12	5.52	-	6.12	5.52	-
Follow-up Hdwy	2.218	-	-	2.218	-	-	3.518	4.018	3.318	3.518	4.018	3.318
Pot Cap-1 Maneuver	1388	-	-	1293	-	-	368	424	879	364	386	894
Stage 1	-	-	-	-	-	-	676	640	-	792	728	-
Stage 2	-	-	-	-	-	-	678	704	-	573	575	-
Platoon blocked, %	-	-	-	-	-	-	-	-	-	-	-	-
Mov Cap-1 Maneuver	1388	-	-	1293	-	-	210	388	879	240	354	894
Mov Cap-2 Maneuver	-	-	-	-	-	-	210	388	-	240	354	-
Stage 1	-	-	-	-	-	-	633	600	-	742	712	-
Stage 2	-	-	-	-	-	-	481	689	-	402	539	-

Approach	EB			WB			NB			SB		
HCM Control Delay, s	1.9			1.1			23.1			21		
HCM LOS							C			C		

Minor Lane/Major Mvmt	NBLn1	NBLn2	NBLn3	EBL	EBT	EBR	WBL	WBT	WBR	SBLn1	SBLn2	SBLn3
Capacity (veh/h)	210	388	879	1388	-	-	1293	-	-	240	354	894
HCM Lane V/C Ratio	0.376	0.369	0.018	0.063	-	-	0.023	-	-	0.285	0.449	0.066
HCM Control Delay (s)	32.1	19.6	9.2	7.8	-	-	7.8	-	-	25.9	23.2	9.3
HCM Lane LOS	D	C	A	A	-	-	A	-	-	D	C	A
HCM 95th %tile Q(veh)	1.6	1.7	0.1	0.2	-	-	0.1	-	-	1.1	2.2	0.2

Intersection						
Int Delay, s/veh	1					
Movement	EBL	EBT	WBT	WBR	SBL	SBR
Lane Configurations		↕	↕		↕	
Traffic Vol, veh/h	30	320	238	20	20	15
Future Vol, veh/h	30	320	238	20	20	15
Conflicting Peds, #/hr	0	0	0	0	0	0
Sign Control	Free	Free	Free	Free	Stop	Stop
RT Channelized	-	None	-	None	-	None
Storage Length	-	-	-	-	0	-
Veh in Median Storage, #	-	0	0	-	0	-
Grade, %	-	6	0	-	0	-
Peak Hour Factor	95	95	85	85	95	95
Heavy Vehicles, %	2	2	2	2	2	2
Mvmt Flow	32	337	280	24	21	16

Major/Minor	Major1	Major2	Minor2		
Conflicting Flow All	304	0	-	0	693 292
Stage 1	-	-	-	-	292 -
Stage 2	-	-	-	-	401 -
Critical Hdwy	4.12	-	-	-	6.42 6.22
Critical Hdwy Stg 1	-	-	-	-	5.42 -
Critical Hdwy Stg 2	-	-	-	-	5.42 -
Follow-up Hdwy	2.218	-	-	-	3.518 3.318
Pot Cap-1 Maneuver	1257	-	-	-	409 747
Stage 1	-	-	-	-	758 -
Stage 2	-	-	-	-	676 -
Platoon blocked, %		-	-	-	
Mov Cap-1 Maneuver	1257	-	-	-	396 747
Mov Cap-2 Maneuver	-	-	-	-	396 -
Stage 1	-	-	-	-	735 -
Stage 2	-	-	-	-	676 -

Approach	EB	WB	SB
HCM Control Delay, s	0.7	0	12.8
HCM LOS			B

Minor Lane/Major Mvmt	EBL	EBT	WBT	WBR	SBLn1
Capacity (veh/h)	1257	-	-	-	496
HCM Lane V/C Ratio	0.025	-	-	-	0.074
HCM Control Delay (s)	7.9	0	-	-	12.8
HCM Lane LOS	A	A	-	-	B
HCM 95th %tile Q(veh)	0.1	-	-	-	0.2

Intersection												
Int Delay, s/veh	26.1											
Movement	EBL	EBT	EBR	WBL	WBT	WBR	NBL	NBT	NBR	SBL	SBT	SBR
Lane Configurations	↖	↑	↗	↖	↑	↗	↖	↗		↖	↑	↗
Traffic Vol, veh/h	130	680	156	53	535	65	72	50	78	30	75	75
Future Vol, veh/h	130	680	156	53	535	65	72	50	78	30	75	75
Conflicting Peds, #/hr	0	0	0	0	0	0	0	0	0	0	0	0
Sign Control	Free	Free	Free	Free	Free	Free	Stop	Stop	Stop	Stop	Stop	Stop
RT Channelized	-	-	None	-	-	None	-	-	None	-	-	None
Storage Length	310	-	420	330	-	235	140	-	-	135	-	135
Veh in Median Storage, #	-	0	-	-	0	-	-	0	-	-	0	-
Grade, %	-	0	-	-	0	-	-	0	-	-	0	-
Peak Hour Factor	100	100	100	95	95	95	85	85	85	95	95	95
Heavy Vehicles, %	2	2	2	2	2	2	2	2	2	2	2	2
Mvmt Flow	130	680	156	56	563	68	85	59	92	32	79	79

Major/Minor	Major1			Major2			Minor1			Minor2		
Conflicting Flow All	631	0	0	836	0	0	1728	1683	680	1769	1771	563
Stage 1	-	-	-	-	-	-	940	940	-	675	675	-
Stage 2	-	-	-	-	-	-	788	743	-	1094	1096	-
Critical Hdwy	4.12	-	-	4.12	-	-	7.12	6.52	6.22	7.12	6.52	6.22
Critical Hdwy Stg 1	-	-	-	-	-	-	6.12	5.52	-	6.12	5.52	-
Critical Hdwy Stg 2	-	-	-	-	-	-	6.12	5.52	-	6.12	5.52	-
Follow-up Hdwy	2.218	-	-	2.218	-	-	3.518	4.018	3.318	3.518	4.018	3.318
Pot Cap-1 Maneuver	951	-	-	798	-	-	~ 70	94	451	65	83	526
Stage 1	-	-	-	-	-	-	316	342	-	444	453	-
Stage 2	-	-	-	-	-	-	384	422	-	259	289	-
Platoon blocked, %		-	-		-	-						
Mov Cap-1 Maneuver	951	-	-	798	-	-	-	75	451	~ 16	~ 67	526
Mov Cap-2 Maneuver	-	-	-	-	-	-	-	75	-	~ 16	~ 67	-
Stage 1	-	-	-	-	-	-	273	295	-	383	421	-
Stage 2	-	-	-	-	-	-	247	392	-	143	249	-

Approach	EB			WB			NB			SB		
HCM Control Delay, s	1.3			0.8						276.7		
HCM LOS							-			F		

Minor Lane/Major Mvmt	NBLn1	NBLn2	EBL	EBT	EBR	WBL	WBT	WBR	SBLn1	SBLn2	SBLn3
Capacity (veh/h)	-	152	951	-	-	798	-	-	16	67	526
HCM Lane V/C Ratio	-	0.991	0.137	-	-	0.07	-	-	1.974	1.178	0.15
HCM Control Delay (s)	-	129.4	9.4	-	-	9.8	-	-	\$ 946.9	272.3	13
HCM Lane LOS	-	F	A	-	-	A	-	-	F	F	B
HCM 95th %tile Q(veh)	-	7.4	0.5	-	-	0.2	-	-	4.5	6.2	0.5

Notes  
 ~: Volume exceeds capacity    \$: Delay exceeds 300s    +: Computation Not Defined    \*: All major volume in platoon