



Storm Water Management Plan

Rocky Mountian Calvary Church - Ellicott

PCD File Number: PPR2420

Project No. 61182

April 4, 2025

prepared for
Rocky Mountain Calvary, Inc.
4285 N Academy Blvd
Colorado Springs, CO 80918

prepared by
MVE, Inc.
1903 Lelaray Street, Suite 200
Colorado Springs, CO 80909
719.635.5736

Qualified Stormwater Manager

Name:

Address:

Phone:

Email:

Contractor

Name:

Address:

Phone:

Email:

Storm Water Management Plan

for

Rocky Mountain Calvary Church - Ellicott
2150 North Ellicott Highway, Calhan, CO

Project No. 61182

April 4, 2025

prepared for

Rocky Mountain Calvary, Inc.
4285 N Academy Blvd
Colorado Springs, CO 80918

prepared by

MVE, Inc.
1903 Lelaray Street, Suite 200
Colorado Springs, CO 80909
719.635.5736

Copyright © MVE, Inc., 2024

61182-SWMP.odt

Contents

1 Site Description	1
1.1 Site Overview.....	1
1.2 Construction Activities.....	2
1.3 Activities Sequence.....	2
1.4 Area & Volume Estimates.....	2
1.5 Existing Soil.....	3
1.6 Existing Vegetation.....	3
1.7 Potential Stormwater Pollution Sources.....	3
1.8 Potential Non-Stormwater Runoff.....	3
1.9 Receiving Waters.....	4
2 Site Map	4
3 Control Measures for Stormwater Pollution Prevention	4
3.1 Structural Erosion and Sediment Controls.....	4
3.2 Nonstructural Erosion and Sediment Controls.....	5
3.3 Materials Handling and Spill Prevention.....	6
4 Final Stabilization and Long-Term Storm Water Management	7
5 Other Stormwater Pollution Controls	7
6 Construction Scheduling	7
7 Inspection and Maintenance	7
References.....	9
Appendix.....	A1

Storm Water Management Plan

This Storm Water Management Plan (SWMP) is required for certification under the Colorado Discharge Permit System – General Permit for Stormwater Discharges Associated with Construction (Stormwater Construction Permit), and has been produced according to the guidelines provided in the *State of Colorado Stormwater Management Plan Guidance for Stormwater Discharges Associated with Construction Activity General Permit Application and Stormwater Management Plan Preparation Guidance*. The goal of this SWMP is to “...identify possible pollutant sources that may contribute pollutants to stormwater, and identify Control Measures (CMs) that, when implemented, will reduce or eliminate any possible water quality impacts.”¹ A current copy of this SWMP must be maintained on the project site for the duration of the construction and stabilization period.

The Permit Holder or their agent will designate a SWMP Administrator for this project. The SWMP Administrator may be the Construction Project Manager, Owner, Construction Site Superintendent or other party so designated by the Permit Holder or their agent. The SWMP Administrator is responsible for implementing, maintaining, and revising the SWMP. The SWMP Administrator is the contact for all SWMP related issues. The SWMP Administrator will have specific site knowledge and authority to adequately manage and direct day-to-day stormwater quality management activities at the site.²

1 Site Description

1.1 Site Overview

The Rocky Mountain Calvary Church - Ellicott site is located in the southeast quarter of the northeast quarter of Section 1, Township 14 south, Range 63 west of the 6th Principal Meridian, El Paso county, Colorado. The property has El Paso County Tax Schedule No. 3400000207. The current address of the site is 2150 North Ellicott Highway.

The Rocky Mountain Calvary Church - Ellicott site is currently occupied by one (1) one-story building housing the Ellicott Campus of Rocky Mountain Calvary Chapel, a gravel parking lot and a children's playground. The remainder of the site contains natural grass and a few sparse trees. The area of the site is 2.639± acres and it is zoned A-5 (Agricultural 5 Acre).

The site slopes from northwest to southeast with grades of approximately 2%. No significant drainageways flow through the site and no significant drainage improvements or drainage facilities currently exist on the site.

The Rocky Mountain Calvary Church - Ellicott site is located in the Hook and Line Ranch Drainage Basin (CHBS1800) of the Black Squirrel Creek Major Drainage Basin (BS). The Hook and Line Ranch Drainage Basin encompasses a portion of El Paso County south of Colorado Springs extending from

¹ [CDPHE], App. A, Section A

² [CDPHE], App. A, Section C.4 (a)

northwest of Judge Orr Rd and Peyton Highway down to Highway 94 east of Ellicott, generally draining southeasterly into Black Squirrel Creek.

The current Flood Insurance Study of the region includes Flood Insurance Rate Maps (FIRM), effective on December 7, 2018.³ The proposed subdivision is included in Community Panel Numbered 08041C0807 G of the Flood Insurance Rate Maps for the El Paso County. No part of the site is shown to be included in a 100-year flood hazard area as determined by FEMA..

1.2 Construction Activities

The proposed construction involves construction of additional gravel parking / drives and concrete ADA parking areas. Minimal earthwork will be performed to prepare the site for construction. Temporary and permanent erosion control measures will be installed as described below. No new structures or placement of fill that changes the elevation of the site shall occur in the 100 year floodplain and no change to the floodplain elevations occur with this project.

1.3 Activities Sequence

Activities will commence with Site Preparation and the installation of Initial Control Measures (CMs) – including Vehicle Tracking Control at the existing gravel drive located along the east edge of the site, which will be used as construction access. General site grading will then begin with removal of topsoil only from those areas that will be refinished with gravel. Because of the small size of the disturbed site, topsoil from the entire construction area may be removed at this time, however, smaller areas will be removed if the construction sequencing so requires. Topsoil, if it is to be stockpiled on the site, requires sediment control log to be installed on the downstream side of the storage area. General site work will then commence after the installation of Sediment Control Logs along the edge of the existing parking and to the west of the existing building as well as silt fence along the southern and western property lines. Utilities will be trenched, grading for the building pad, parking lot and detention pond will then commence. Promptly following completion of the installation of the new asphalt parking / drives areas, redistribution of topsoil, mulching and seeding will be applied to all disturbed areas that will not be further disturbed. Following the construction of these items, final “touch up” grading and redistribution of topsoil will be done for all remaining disturbed unpaved areas on the site. Then, seeding and mulching will be applied to all remaining disturbed areas. The site will then be ready for initial close out. The perimeter Sediment Control Logs and Silt Fence will remain until site stabilization. At the time of final stabilization, all remaining construction CM's will be removed, and seeding and mulching will be placed over the resulting disturbed area.

Project closeout will be established at final stabilization. Final stabilization is reached when all ground surface disturbing activities at the site have been completed, and uniform vegetative cover has been established with an individual plant density of at least 70 percent of pre-disturbance levels, or equivalent permanent, physical erosion reduction methods have been employed⁴. Construction Scheduling is as defined in Section 6, below.

1.4 Area & Volume Estimates

The Rocky Mountain Calvary Church - Ellicott site encompasses 2.639 ± acres. Within that total area, approximately 2.5 acres are expected to undergo clearing, asphalt placement or other disturbance due to the construction activities of the Rocky Mountain Calvary Church - Ellicott. The total disturbed area also includes some adjacent offsite areas to the north to construct a shared asphalt drive.

Earthwork activities will comprise of more than 500 cy or cut / fill. The excess cut material cut will be exported to an offsite location. All areas impacted by earth movement shall be seeded and mulched and shall meet all erosion control requirements indicated within this Storm Water Management Plan.

³ [FIRM]
⁴ [UDFCD-V3], Ch. 7, 3.1

1.5 Existing Soil

According to the National Resource Conservation Service, there are two (2) soil type identified in the Rocky Mountain Calvary Church - Ellicott site. The primary soil is Ellicott loamy coarse sand, 0 to 5 percent slopes (map unit 28) lying in the west 80% of the site.

Ellicott loamy coarse sand (map unit 28) is deep and somewhat excessively well drained, has rapid permeability, slow surface runoff and high hazard of erosion. Ellicott loamy sand is classified as being part of Hydrologic Soil Group A.

The east 20% of the site is made up of Sampson loam, 0 to 3 percent slopes (map unit 78).

Sampson loam is deep and well drained, has moderate permeability, slow surface runoff and slight hazard of erosion. Sampson loam is classified as being part of Hydrologic Soil Group B.

A portion of the Soil Map and data tables from the National Cooperative Soil Survey and relevant Official Soil Series Descriptions (OSD) are included in the **Appendix**.^{5 6}

The impervious area on the site is being increased by the addition of a new building and asphalt parking / drives and a new detention pond. The drainage patterns on and off site will not be significantly altered as a result of the proposed construction activities.

1.6 Existing Vegetation

A visual inspection of the site identified the existing conditions to be primarily pasture/meadow with 70% ground cover and gravel covering the existing parking areas.

1.7 Potential Stormwater Pollution Sources

The primary potential stormwater pollution source from the Rocky Mountain Calvary Church - Ellicott is sediment resulting from erosion. There is potential for sediment carrying stormwater to originate from nearly anywhere within the site, and such runoff might deposit sediment onto any of the downstream properties or into the downstream receiving waters. Erosion control and sediment reduction measures will be implemented to mitigate potential pollution from sediment. Such measures are described in the below section **Control Measures for Stormwater Pollution Prevention**.

No significant storage of chemicals will occur on site. Small amounts of vehicle and equipment fuel and maintenance chemicals (oil, antifreeze, hydraulic fluid, etc.) may be stored on site, but all such materials will be stored in appropriately contained and managed facilities. Storage of materials is described in the below section **Control Measures for Stormwater Pollution Prevention**.

Chemicals released from vehicles and equipment may also be a source of stormwater pollution. Appropriate procedures will be taken to limit the potential of stormwater pollution from spills and leaks. No significant maintenance of vehicles and equipment and no vehicle and equipment washing may be performed on site. "Rinsing of construction vehicles carrying concrete may only be performed in designated concrete rinse facilities." Proper handling of vehicles and equipment is described in the below section **Control Measures for Stormwater Pollution Prevention**.

1.8 Potential Non-Stormwater Runoff

Temporary irrigation for the establishment and/or maintenance of ground cover may also be a source of non-stormwater runoff from the site. This non-stormwater runoff is permitted under the Stormwater Construction Permit; however, appropriate irrigation practices will be used to limit the potential of runoff, and any runoff that does occur will be treated with the same control measures applied to stormwater runoff. Proper management of the irrigation schedules and duration will minimize excess irrigation runoff. The construction CM's described below which are to remain in place until ground cover is established, as well as the permanent CM's described below will mitigate the potential of such irrigation water becoming a non-stormwater runoff source.

5 [WSS]

6 [OSD]

1.9 Receiving Waters

Runoff from this site flow generally from west to east before draining southeasterly into Black Squirrel Creek.

2 Site Map

A **Site Map** is included with this SWMP for the Rocky Mountain Calvary Church - Ellicott. The **Site Map** consists of the Rocky Mountain Calvary Church - Ellicott Erosion Control Plan as submitted and approved by El Paso County. The **Site Map** includes construction site boundaries, areas of ground surface disturbance, areas of cut and fill, areas used for storage of building materials, equipment, soil, and waste, the locations of structural and non-structural Control Measures, the locations of the existing water courses (if any exist), the soil type areas, existing and proposed contours, proposed structures and improvements, an explanation of the existing vegetation on the site, locations of existing water courses, locations of existing 100-year floodplains (if any exist), locations of existing and proposed utilities and a vicinity map. There are no asphalt or concrete batch plants planned and therefore are not shown on the **Site Map**.

3 Control Measures for Stormwater Pollution Prevention

“Control Measures (CMs) encompass a wide range of erosion and sediment control practices, both structural and non-structural in nature, that are intended to reduce or eliminate any possible water quality impacts from stormwater leaving a construction site.”⁷ “Structural CMs” traditionally refers to any physical process, but in this SWMP “structural CMs” refers only to practices involving the installation of a specific, definable object or structure. “Nonstructural CMs” traditionally refers to definitions of operational and managerial techniques, but in this SWMP “nonstructural CMs” also includes any physical process not involving the installation of a specific, definable object or structure. “Erosion control CMs” prevent or reduce erosion, while “sediment control CMs” remove or reduce sediment from runoff. Because sediment resulting from erosion is typically the primary pollutant of stormwater runoff from a construction site, erosion control practices are considered the primary and preferred method of stormwater pollution prevention in this SWMP, while sediment control practices will be implemented as secondary measures or when erosion control practices are not possible or are not fully effective. Prevention of stormwater pollutants other than sediment are addressed under an additional set of materials handling and spill prevention CMs.⁸

3.1 Structural Erosion and Sediment Controls

Before any other construction activities commence on the site, **Vehicle Tracking Controls (VTC)** will be installed at all site access points. Vehicle tracking control helps reduce the deposition of sediment, dirt, mud, and debris by vehicles exiting the site onto the streets adjacent to the site. The locations of site entrance vehicle tracking controls are identified on the **Site Map**, and details for the installation and maintenance of the controls are included in the **Appendix**.⁹

Before any grading or other significant disturbance occurs on any of the phased portions of the site, **Silt Fence (SF)** will be installed along any edge of an area to be disturbed where runoff would otherwise go untreated. Silt fence will be also installed along those portions of the site perimeter where potentially sediment laden runoff may flow into adjacent properties. Silt fence will also be installed along the downstream edges of the topsoil stockpile. Silt fences help reduce pollution of stormwater by “filtering” out some of the sediment carried by runoff flowing through the fences and by facilitating deposition of sediment by slowing the runoff. Silt fences can also help reduce erosion by slowing and distributing runoff. The locations of silt fences are identified on the **Site Map**, and details for the installation and maintenance of silt fences are included in the **Appendix**. In addition to the silt fences indicated on the **Site Map**, silt fences will be installed wherever the contractor deems

7 [CDPHE], App. A, Section B

8 [CDPHE], App. A, Section C.1 (4)

9 [SCM], App. E, VTC

them to be necessary or helpful. Silt fence installed at the contractor's discretion might not be shown on the **Site Map**.¹⁰

Sediment Control Logs (SCL) will be installed along any edge of an area to be disturbed where runoff would otherwise go untreated. Sediment Control Logs will be also installed along those portions of the site perimeter where potentially sediment laden runoff may flow into adjacent properties. Sediment Control Logs helps reduce pollution of stormwater by “filtering” out some of the sediment carried by runoff flowing through the fences and by facilitating deposition of sediment by slowing the runoff. Sediment Control Logs can also help reduce erosion by slowing and distributing runoff. The locations of Sediment Control Logs are identified on the **Site Map**, and details for the installation and maintenance of Sediment Control Logs are included in the **Appendix**. In addition to the Sediment Control Logs indicated on the **Site Map**, Sediment Control Logs will be installed wherever the SWMP Administrator deems them to be necessary or helpful. Sediment Control Logs installed at the SWMP Administrator's discretion shall be added to the **Site Map** by the SWMP Administrator.¹¹

Straw Bale Barriers (SBB) are an additional means of erosion control measures which are available for use on the site, but not included on the **Site Map**. Straw bale barriers help reduce pollution of stormwater by “filtering” out much of the sediment carried by runoff flowing through the barriers and by facilitating deposition of sediment by slowing the runoff. Straw bale barriers also help reduce erosion by slowing and distributing runoff. Details for the installation and maintenance of straw bale barriers are included in the **Appendix**. Straw Bale barriers may be installed wherever the contractor deems them to be necessary or helpful. Straw bale barriers installed at the contractor's discretion might not be shown on the **Site Map**.¹²

Following the installation of the initial CM's described above, grading and utility construction on the site may commence.

3.2 Nonstructural Erosion and Sediment Controls

In order to minimize the total amount of soil exposed at any given time to “reduce the period of accelerated soil erosion”¹³ the construction activities of the Rocky Mountain Calvary Church - Ellicott will be scheduled as described in the above section **Activities Sequence**. In addition to the schedule described in the above section **Activities Sequence**, many of the details and specifications included in the index provide specific scheduling information.

Before construction activities commence in any area of the site, the full layer of topsoil will be stripped only from the portions of that area that are to be disturbed and will be stockpiled in the location identified on the **Site Map**. Rather than stripping topsoil from the entire site at once, as has been the traditional practice in some cases, topsoil will be stripped from particular areas of the site only as construction work progresses to that area as described in the above section **Activities Sequence**. Soils stockpiled for more than 60 days will be seeded and mulched within 14 days of completion of stockpiling activities.¹⁴

Before construction activities commence in any area of the site, the construction vehicle traffic areas to and around that area – including all construction roads, parking areas, loading and unloading zones, storage areas, and staging areas – will be stabilized through proper grading, compaction, and surfacing. Stabilization of traffic areas reduces erosion and vehicle tracking thus helping to eliminate potential pollution of stormwater by sediment. To prevent vehicle tracking of soil into the surrounding roadways, construction related traffic will be limited to entering the site at the designated construction entrance(s). The construction entrance will have a Vehicle Tracking Control as described above. Should significant soil still be deposited on the surrounding roadways, street sweeping will be utilized on paved roads and manual removal of errant mud deposits will be utilized on unpaved roads to remove the polluting soil from the roadways immediately following deposition.

10 [SCM], App. E, SF

11 [UDFCD-V3], SC-1

12 [UDFCD], SC-2

13 [UDFCD-V3], Ch 7, 2.3

14 [UDFCD-V3], MM-2

Mulch will be applied, in addition to soil roughening and seeding, to all disturbed areas (not otherwise stabilized) immediately if possible or within 14 days of completion of final grading. Additionally, mulch will be applied to all disturbed areas that are not at final grade but will remain dormant (undisturbed) for longer than 30 days. Mulch helps prevent erosion “by protecting bare soil from rainfall impact, increasing infiltration, and reducing runoff.”¹⁵ The locations of some areas to receive mulch are identified on the **Site Map** (some areas requiring mulch may not be indicated), and specifications for revegetation are included in the **Appendix**.

When seasonally appropriate, seed will be applied to all disturbed areas (not otherwise stabilized) immediately if possible or within 14 days of completion of final grading. Additionally, seed will be applied to all disturbed areas that are not at final grade but will remain dormant (undisturbed) for longer than 1 year. When the season is inappropriate for seed application, surface roughening and mulch will be applied within 14 days and seed will be applied as soon as seasonally appropriate. The locations of some areas to receive seed are identified on the **Site Map** (some areas requiring seed may not be indicated), and specifications for revegetation are included in the **Appendix**.

3.3 Materials Handling and Spill Prevention

A vigorous program of “good housekeeping” will be implemented on the Rocky Mountain Calvary Church - Ellicott site in an effort to prevent stormwater pollution by materials used and stored on-site.

No significant storage of chemicals and other potentially pollutive materials will be allowed on site. Only those chemicals and materials necessary for the described construction activities may be stored on site, and then only in the smallest amounts reasonable and for the shortest time possible. The location of a storage area for toxic, hazardous, and potentially pollutive materials is identified on the **Site Map** and a specification for on site materials handling is provided in the **Appendix**.

Portable toilets will be located away from direct traffic routes and will be situated out of the potential path of any potential stormwater runoff. Any grading necessary to achieve such a situation will be completed before the portable toilets are delivered to the site. The locations of portable toilets shall be determined by the Contractor and identified on the **Site Map**. They shall be located a minimum of 10 feet from any storm inlets and 50 feet from state waters. Portable toilets will be securely anchored at all four corners to prevent tipping. Portable toilets shall be inspected daily for spills.

Fueling and minor preventative maintenance of vehicles and equipment may occur only on areas specifically stabilized for construction vehicle traffic. Appropriate procedures will be taken to limit the potential of stormwater pollution from spills and leaks. The locations of areas specifically stabilized for construction vehicle traffic are identified on the **Site Map** and a specification for vehicle and equipment handling is provided in the **Appendix**. No significant maintenance of vehicles and equipment and no vehicle and equipment washing will be performed on site.

Any spills of potential pollutants on the site related to the construction activities will be addressed according to the requirements of Colorado Department of Public Health and Environment, Hazardous Materials and Waste Management Division.

Appropriate spill prevention and response measures will be implemented on the site. The details and specifications referenced above in this section provide general and specific guidelines for spill prevention and response measures relating to the various potential non-sediment pollution sources.

No groundwater and/or stormwater dewatering activities are proposed or expected for the proposed construction activities.

No significant waste generation is expected as a result of the proposed construction activities. Any minor waste that is produced will be disposed of properly in waste disposal bins. (See Inspection and Maintenance section below for inspection and emptying frequency.)

There will be no asphalt or concrete batch plants on site.

¹⁵ [UDFCD-V3], EC-4

4 Final Stabilization and Long-Term Storm Water Management

According to the Stormwater Construction Permit “Final stabilization is reached when all soil disturbing activities at the site have been completed, and uniform vegetative cover has been established with a density of at least 70 percent of pre-disturbance levels or equivalent permanent, physical erosion reduction methods have been employed.”¹⁶ Such a viable vegetative cover will be established within one year of completion of construction activities on all disturbed areas not otherwise stabilized. Unless otherwise indicated on a landscape plan, revegetation will be achieved through seedbed preparation, including but not necessarily limited to soil roughening, seeding, mulching, and irrigating when specified. Soil roughening, mulching, and seeding are all described in the above section **Control Measures for Stormwater Pollution Prevention**, and specifications for surface stabilization and revegetation are included in the **Appendix**.

In order to prevent or control erosion and pollution of stormwater by sediment after completion of construction activities, many of the structural CMs described in the above section **Control Measures for Stormwater Pollution Prevention**, will remain in place until final stabilization. CMs that must remain in place until final stabilization shall be removed following final stabilization and the resulting disturbed areas shall be seeded and mulched. The specifications or details corresponding to each CM provide general guidelines for the removal of the CM.

Long-Term Storm Water Management shall be accomplished through the use of a permanent Full Spectrum Extended Detention Basin located in the southwest corner of the site. This shall provide the necessary long-term storm water management.

5 Other Stormwater Pollution Controls

This project does not rely on control measures owned or operated by another entity. All stormwater pollution control measures to be implemented on the Rocky Mountain Calvary Church - Ellicott site are included in the above sections **Control Measures for Stormwater Pollution Prevention** and **Final Stabilization and Long-Term Storm Water Management**.

6 Construction Scheduling

The expected timing of the project is to install initial erosion control CM's and start grading Spring 2025. Grading and site operations are expected to continue through Fall 2025, with final stabilization by Spring 2026. Activities are expected to proceed as written above. Final Stabilization is described in the **Final Stabilization and Long-Term Storm Water Management** section.

7 Inspection and Maintenance

The primary purpose of a regular inspection is to “determine if there is evidence of, or the potential for, pollutants entering the drainage system.”¹⁷ “The Stormwater Construction Permit requires that a thorough inspection of the stormwater management system be performed and documented at least every 14 days, and after any precipitation or snowmelt event...that results in stormwater running across the ground.”¹⁸ This is only a minimum requirement and more frequent inspection and regular maintenance of the stormwater management system is typically necessary to effectively reduce pollutants in stormwater discharges from a construction site. A thorough inspection of the Rocky Mountain Calvary Church - Ellicott site will therefore be performed and documented weekly and after any precipitation or snowmelt event that results in stormwater running across the ground. Additionally, the SWMP Administrator should monitor rainfall events that may occur upstream and cause flooding within the 100 year floodplain that lies across a portion of the site. Additional inspections may be required after offsite events to ensure no damage has occurred to any erosion control measures.

¹⁶ [CDPHE], App. A, Section C.5

¹⁷ [CDPHE], App. A, Section C.6 (b)

¹⁸ [CDPHE], App. A, Section C.6 (a)

The regular inspections of the site will include observation of the construction site perimeter and all stormwater discharge points including storm drain system inlets and culverts. CMs applied in the site perimeter or around stormwater discharge points include inlet protection, site entrance vehicle tracking controls, silt fences, straw bale barriers, and straw bale check structures. Specific inspection and maintenance requirements for each of these CMs are included in the **Appendix**.

The regular inspections of the site will also include observation of all disturbed areas and all stabilized and revegetated areas. Inspection of these areas will involve particular attention on possible erosion problems. Specifications for surface stabilization and revegetation are included in the **Appendix** and provide specific inspection and maintenance requirements.

The regular inspections of the site will also include observation of material storage areas including waste disposal bins and topsoil stockpiles. Inspection of these areas will involve particular attention on possible leaks and spills and, in the case of the topsoil stockpile, on possible ineffectively managed runoff. Any leaking waste disposal bins shall be replaced prior to the next inspection. Waste disposal bins shall be emptied upon reaching 90% capacity. Specifications for on site materials handling and details for silt fence, used around topsoil stockpiles, are included in the **Appendix** and provide specific inspection and maintenance requirements.

All structural CMs on the site will be thoroughly examined during each inspection to “determine if they still meet the design and operational criteria in the SWMP and that they continue to adequately control pollutants at the site.”¹⁹ Details of each CM, with specific inspection and maintenance requirements, are included in the **Appendix**.

Following each inspection, repairs will be performed on CMs that are found to no longer function as needed and designed, and preventative maintenance will be exercised on CMs as needed to ensure continued operation. CMs that have failed or have the potential to fail without maintenance or modifications will be addressed immediately to prevent the discharge of pollutants. As described above, the details of each CM, included in the **Appendix**, provided specific maintenance instructions and requirements. When a CM is found to be ineffective in preventing discharge of pollutants, even though the CM is in good repair and is functioning as designed, that CM will be modified or an alternative or additional CM will be installed promptly.²⁰

An **Inspection Log** will be maintained on site in an enclosed seal receptacle near the site entrance and will include a record of all stormwater management system inspections along with all CM maintenance and repair activities²¹. Said inspection log will be signed and dated by the SWMP Administrator after each inspection. All the inspection, maintenance, and repair requirements for each CM, as described in this SWMP and as outlined in the details or specifications in the **Appendix**, will be performed as specified and will be recorded in the **Inspection Log**. The **Inspection Log** will also include a description of any incidence of non-compliance, such as uncontrolled releases of pollutants including mud, muddy water or measurable quantities of sediment found off the site along with a description of measures to be taken to cleanup pollutants that have left the site and a description of measures to be taken to prevent future pollutive discharges. Records of any spills, leaks, or overflows of non-sediment potential pollutants, whether or not such a spill, leak, or overflow results in pollution of stormwater, will be included.

Following an inspection that does not reveal any incidents of non-compliance, or following the completion of measures taken to correct any non-compliance issues, a **Certification** indicating the site is in compliance will be signed and dated.

In addition to regularly maintaining an **Inspection Log** and **Certification**, this SWMP will be updated regularly to reflect the actual stormwater management system as implemented on the site.

19 [CDPHE], App. A, Section C.6 (b)

20 [CDPHE], App. A, Section C.6 (c)

21 [CDPHE], App. A, Section C.6 (d)

References

CDPHE: Colorado Department of Public Health & Environment, Water Quality Control Division, *State of Colorado Stormwater Management Plan Guidance for Stormwater Discharges Associated with Construction Activity* (State of Colorado:Denver , April, 2011).

FIRM: Federal Emergency Management Agency, National Flood Insurance Program, *Flood Insurance Rate Map* (FEMA:Washington D.C. , March 17, 1997).

OSD: United States Department of Agriculture, Natural Resources Conservation Service, *NRCS Official Soil Series Descriptions* (: , March, 2018).

SCM: City of Colorado Springs Stormwater Enterprise, *Stormwater Construction Manual* (:Colorado Springs, CO , December 2020).

UDFCD: Mile High Flood District, *Urban Storm Drainage Criteria Manual Volume 3 - Best Management Practices* (Mile High Flood District:2480 W. 26th Ave. Ste 156B, Denver, CO 80211 , September 1992, Updated January 2016).

UDFCD-V3: Urban Drainage and Flood Control District, *Urban Storm Drainage Criteria Manual, Volume 3: Best Management Practices* (Urban Drainage and Flood Control District:2480 W. 26th Ave. Ste 156B, Denver, CO 80211 , September 1992, Updated November 2015).

WSS: United States Department of Agriculture, Natural Resources Conservation Service, *NRCS Web Soil Survey* (: , March, 2018).

Appendix

Vicinity Map

Sample Field Inspection Sequence and Field Inspection Report

CM Installation and Maintenance Details*

<u>Colorado Springs SCM Detail and Description</u>	<u>Map Key Abbreviation</u>
CD – Check Dam	CD
CIP – Culvert Inlet Protection	CIP
CWA – Concrete Washout Area	CWA
ECB – Erosion Control Blanket	ECB
IP – Inlet Protection	IP-1, IP-2, IP-3, IP-4
PT – Portable Toilet	PT
RS – Rock Sock	RS
SCL – Sediment Control Log	SCL
SF – Silt Fence	SF
SM – Seeding and Mulching	SM
SP – Stockpile Protection	SP
SR – Surface Roughening	SR
ST – Slope Tracking	ST
TCB – Temporary Compacted Berm	TCB
TSB – Temporary Sediment Basin	TSB
TSD – Temporary Slope Drain	TSD
VTC – Vehicle Tracking Control	VTC

<u>UDFCD Detail and Description</u>	<u>Map Key Abbreviation</u>
EC-10 – Earth Dikes and Drainage Swales	ED/DS
SM-6 – Stabilized Staging Area	SSA
SM-7 – Street Sweeping and Vacuuming	SS
MM-3 – Good Housekeeping Practices	GH

GEC Plans

Appendix

Vicinity Map

Sample Field Inspection Sequence and Field Inspection Report

CM Installation and Maintenance Details*

<u>Colorado Springs SCM Detail and Description</u>	<u>Map Key Abbreviation</u>
CD – Check Dam	CD
CIP – Culvert Inlet Protection	CIP
CWA – Concrete Washout Area	CWA
ECB – Erosion Control Blanket	ECB
IP – Inlet Protection	IP-1, IP-2, IP-3, IP-4
PT – Portable Toilet	PT
RS – Rock Sock	RS
SCL – Sediment Control Log	SCL
SF – Silt Fence	SF
SM – Seeding and Mulching	SM
SP – Stockpile Protection	SP
SR – Surface Roughening	SR
ST – Slope Tracking	ST
TCB – Temporary Compacted Berm	TCB
TSB – Temporary Sediment Basin	TSB
TSD – Temporary Slope Drain	TSD
VTC – Vehicle Tracking Control	VTC

<u>UDFCD Detail and Description</u>	<u>Map Key Abbreviation</u>
EC-10 – Earth Dikes and Drainage Swales	ED/DS
SM-6 – Stabilized Staging Area	SSA
SM-7 – Street Sweeping and Vacuuming	SS
MM-3 – Good Housekeeping Practices	GH

GEC Plans

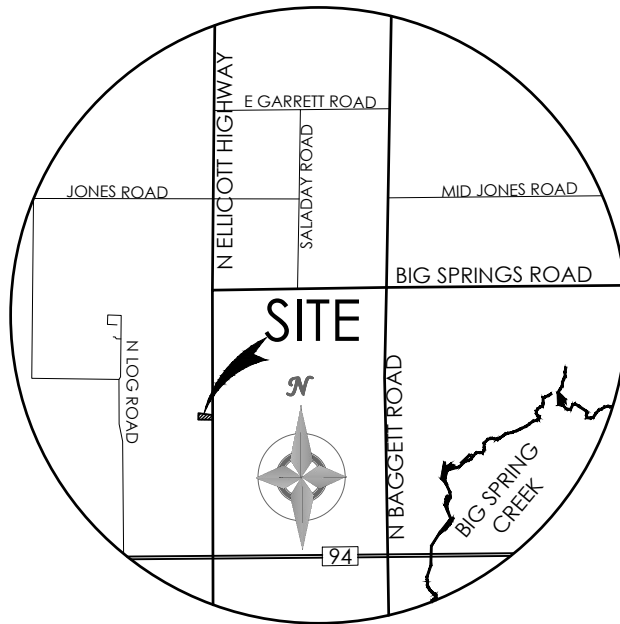

VICINITY MAP

NOT TO SCALE

COLORADO DEPARTMENT OF TRANSPORTATION STORMWATER FIELD INSPECTION REPORT - ACTIVE CONSTRUCTION

(1) Project Name:	(2) Project Contractor:	(3) SWMP Administrator (Qualified Stormwater Manager) / Erosion Control Inspector:	
(4) CDOT Project Engineer/CDOT Designee:	(5) Other Attendee(s) (Name and Title):		
(6) CDOT Project Number:	(7) Project Code (Sub Account #):	(8) CDPS-SCP Certification#:	(9) CDOT Region:
(10) Date of Project Inspection:	(11) Weather at Time of Inspection:		

(12) REASON FOR INSPECTION / EXCLUSION

- Routine Inspection: (A routine erosion control inspection shall be conducted at a minimum, once every 7 Calendar Days)
- Runoff Event: (Post-storm event inspections must be conducted within 24 hours after the end of any precipitation or snowmelt event that causes surface erosion. If no construction activities will occur following a storm event, post-storm event inspections shall be conducted prior to re-commencing construction activities, but no later than 72 hours following the storm event. The occurrence of any such delayed inspection must be documented in the inspection record.) Routine inspections still must be conducted every 7 calendar days.
 Storm Start Date: _____ Approximate End Time of Storm (hrs): _____
- Third Party Request: Winter Conditions Inspections Exclusion: Inspections are not required at sites where construction activities are temporarily halted, snow cover exists over the **entire site** for an extended period, **and melting conditions posing a risk of surface erosion do not exist**. This exception is applicable only during the period where **melting conditions do not exist**, and applies to the routine 7-day inspections, as well as the post-storm-event inspections. If **visual inspection** of the site verifies that all of these conditions are satisfied, document the conditions in section 17 (General Notes) and proceed to section 18 (Inspection Certification). Documentation must include: dates when snow cover existed, date when construction activities ceased, and date when melting conditions began.
- Other:

(13) SWMP MANAGEMENT

	Yes	No	N/A	(g) Reason for N/A
(a) Is the SWMP located on site?	<input type="checkbox"/>	<input type="checkbox"/>	<input type="checkbox"/>	
(b) Are changes to the SWMP documents noted and approved?	<input type="checkbox"/>	<input type="checkbox"/>	<input type="checkbox"/>	
(c) Are the inspection reports retained in the SWMP?	<input type="checkbox"/>	<input type="checkbox"/>	<input type="checkbox"/>	
(d) Are corrective actions from the last inspection completed?	<input type="checkbox"/>	<input type="checkbox"/>	<input type="checkbox"/>	
(e) Is the Spill Response Plan updated in the SWMP?	<input type="checkbox"/>	<input type="checkbox"/>	<input type="checkbox"/>	
(f) Is a list of potential pollutants updated in the SWMP?	<input type="checkbox"/>	<input type="checkbox"/>	<input type="checkbox"/>	

(14) CURRENT CONSTRUCTION ACTIVITIES

(a) Describe current phase of construction activities

(b) Estimate of disturbed area at the time of the inspection, use guidance found in 208.04 (e):

	Acres	Notes
Temporary Stabilization (includes areas of vertically tracked and/or surface roughened temporary stabilizing surface treatments) +		
Interim Stabilization (spray on soil tackifier such as organic mulch tackifier, bonded fiber matrix, wood cellulose fiber with tackifier, etc.) +		
Permanent Stabilization (includes areas of permanent seeding that have not achieved 70% of pre-disturbance vegetation levels) +		
Other (Includes ground disturbing, clearing and grubbing, materials storage, equipment staging, haul roads) +		
Total acres of disturbance (includes cumulative total number of acres including: temporary, interim, permanent stabilized and other) =		

(c) Has the SWMP Phased Control Measure Implementation Matrix been updated? Yes No

(16) CONSTRUCTION SITE ASSESSMENT **Off-site Pollutant Discharges are a Violation of the Permit and Reason for Immediate Project Suspension**

- (a) Is there evidence of discharge of sediment or other pollutants from the site? Yes No
*If yes, explain the discharge, the location and the associated corrective actions in section 15 (Construction Site Assessment & Corrective Actions) or section 18 (General Notes).
- (b) Has sediment or other pollutants discharging from the site reached State waters? Yes No
*If yes, see subsection 208.03(c) and Part I.L.6 of the permit for reporting requirements.

(17) GENERAL NOTES

(18) INSPECTION CERTIFICATION

By signing this form, I certify that I attended the inspection in accordance with specification 208.03.

Contractor's SWMP Administrator (Qualified Stormwater Manager)

Print Name:

Signature Required:

Date:

Contractor's Erosion Control Inspector (If Needed):

Print Name:

Signature (if needed)

Date:

(19) COMPLIANCE CERTIFICATION

I verify that, to the best of my knowledge and belief, that if any corrective action items were identified during the inspection, those corrective actions are complete, and the site is currently in compliance with the permit (Part I.A.3.f.i.).

Contractor's SWMP Administrator/ECI

Print Name:

Signature Required:

Date

Contractor's Superintendent/Approved Designee

Print Name:

Signature Required:

Date:

CDOT Project Engineer/CDOT Designee

Print Name:

Signature Required:

Date:

Stormwater Management Field Inspection Report Instructions

State waters are defined to be any and all surface and subsurface waters which are contained in or flow through the state, including, streams, rivers, lakes, drainage ditches, storm drains, ground water, and wetlands, but not including waters in sewage systems, waters in treatment works of disposal systems, waters in potable water distribution systems, and all water withdrawn for use until use and treatment have been completed. (Per subsection 107.25 and 25-8-103 (19) CRS)

- (3) SWMP Administrator (Qualified Stormwater Manager) and Erosion Control Inspector:** Indicate the name(s) of the individual responsible for implementing, maintaining and revising the SWMP. An Erosion Control Inspector(s) may be the SWMP Administrator in projects with not more than 40 acres of disturbance (see 208.03(c)).
- (4) CDOT Project Engineer/CDOT Designee:** Indicate the name of the CDOT representative performing the inspection with the SWMP Administrator/Erosion Control Inspector(s). This person should be the Project Engineer or an authorized representative.
- (9) CDPS-SCP Certification #:** Indicate the Colorado Discharge Permit System (CDPS) Stormwater Construction Permit (SCP) (for Stormwater Discharges Associated with Construction Activities) certification number, issued by CDPHE, for the project which the report is being completed. Certification number can be found on the first page of the SCP.
- (12) Reason(s) for Inspection / Exclusion:** Indicate the purpose for the inspection or exclusion. These inspections are required to comply with the CDOT Specifications and the CDPS-SCP.
- Routine Inspections. These inspections are required at least every 7 calendar days during active construction. Suspended projects require the 7 calendar day inspection unless snow cover exists over the entire site for an extended period of time, and melting conditions do not exist (see, Winter Conditions Inspections Exclusions). Runoff Event Inspection for Active Sites. See page 1 for definition.
 - Third Party Request. Indicate the name of the third party requesting the inspection and, if known, the reason the request was made.
 - Winter Conditions Inspections Exclusions. See page 1 for definition. An inspection does not need to be completed, but use this form to document the conditions that meet the Exclusion. Other. Specify any other reason(s) that resulted in the inspection.
- (13) SWMP Management:** Review the SWMP records and documents and use a ✓ to answer the question. To comply with CDOT Standard Specifications and the CDPS-SCP, all of the items identified must be adhered to. If No is checked, indicate the necessary corrective action in section 15 (Construction Site Assessment & Corrective Actions). Specification 208.03(d).
- a) A copy of the SWMP must be retained on site, unless another location (specified by the permit) is approved by the Division.
 - b) Indicate all changes that have been made to any portion of the SWMP documents during construction. Changes shall be dated and signed at the time of occurrence. Amendments may include items listed in subsection 208.03(d).
 - c) The SWMP Administrator shall keep a record of inspections. Inspection reports must identify any incidents of noncompliance with the terms and conditions of the CDOT specifications or the CDPS-SCP. Inspection records must be retained for three years from expiration or inactivation of permit coverage.
 - d) Are corrective actions from the last inspection completed? Is a description of the corrective action(s), the date(s) of the corrective action(s), and the measure(s) taken to prevent future violations (including changes to the SWMP, as necessary) documented?
 - e) Subsection 208.06(c) requires that a Spill Response Plan be developed and implemented to establish operating procedures and that the necessary employee training be provided to minimize accidental releases of pollutants that can contaminate stormwater runoff. Records of spills, leaks or overflows that result in the discharge of pollutants must be documented and maintained. Information that should be recorded for all occurrences include the time and date, weather conditions, reasons for spill, etc. Some spills may need to be reported to the Water Quality Control Division immediately.
 - f) (f) Subsection 107.25(b)6 requires the Erosion Control Supervisor to identify and describe all potential pollutant sources, including materials and activities, and evaluate them for the potential to contribute pollutants to stormwater discharge.
 - g) (g) If N/A is checked for any of the items (a) through (f), indicate why in the space provided, if additional space is needed indicate in section 17 (General Notes).

Stormwater Management Field Inspection Report Instructions (continued)

(14) Current Construction Activities:

- a) Provide a short description of the current construction activities/phase at the project site; include summary of grading activities, installation of utilities, paving, excavation, landscaping, etc.
 - (1) Estimate of disturbed area at the time of the inspection, use guidance found in 208.04 (e). Estimate the acres of disturbed area at the time of the inspection. Include clearing, grading, excavation activities, areas receiving overburden (e.g. stockpiles), demolition areas and areas with heavy equipment/vehicle traffic, installation of new or improved haul roads and access roads, staging areas, borrow areas and storage that will disturb existing vegetative cover, (Areas that have been: hard armored or paved should not be counted for total disturbance).
- b) Has the Phased control measure Implementation Matrix on the SWMP been updated? As part of the inspection the Phased control measure Implementation matrix for both the structural and non-structural control measures found at the beginning of the SWMP sheets must be reviewed to ensure that "In use on site" box is checked for control measures currently in use at the time of the inspection.

(15) Construction Site Assessment & Corrective Actions: Inspect the construction site and indicate where control measure feature(s) identified in section 13 (SWMP Management), require corrective action. Erosion and sediment control practices identified in the SWMP shall be evaluated to ensure that they are operating correctly.

- Condition. Identify the condition of the control measure, using more than one letter (identified in section 15) if necessary.
- Location. Site location (e.g., project station number, mile marker, intersection quadrant, etc.).
- Control measure. Indicate the type of control measure at this location that requires corrective action (e.g., silt fence, erosion logs, soil retention blankets, etc.).
- Date Completed & Initials. Date and initial when the corrective action was completed and the preventative measure statement finished.
- Description of Corrective Action and Preventative Measure Taken. Provide the proposed corrective action needed to bring the area or control measure into compliance. Once corrective actions are completed, state the measures taken to prevent future violations and ensure that the control measures are operating correctly, including the required changes made to the SWMP.

Inadequate control measure: Is any control measure that is not designed or implemented in accordance with the requirements of the permit and/or any control measure that is not implemented to operate in accordance with its design, this includes control measures that have not been implemented for pollution sources. If it is infeasible to install or repair the control measure immediately after discovering the deficiency the reason must be documented and a schedule included to return the control measure to effective operating condition as soon as possible.

Control measures requiring routine maintenance: Any control measure that is still operating in accordance with its design and the requirements of the permit, but requires maintenance to prevent a breach of the control measure. These items are not subject to the corrective action requirements as specified in Part I.b.1.c of the permit.

Additional: Any control measure inadequate for its application or an area with insufficient control measure(s). If it is infeasible to install revised or additional control measure(s) immediately after discovering the deficiency the reason must be documented and a schedule included to return the control measure to effective operating condition as soon as possible.

Remove: Control measure no longer necessary

(16) Construction Site Assessment: Was there any off site discharge of sediment at this site since the last inspection?

- a) Is there evidence of discharge of sediment or other pollutants from the site? **Off-site pollutant discharges are a violation of the permit.** (The construction site perimeter, all disturbed areas, material and/or waste storage areas that are exposed to precipitation, discharge locations, and locations where vehicles access the site shall be inspected for evidence of, or the potential for, pollutants leaving the construction site boundaries, entering the stormwater drainage system).
- b) Are pollutants discharging to State water?
- c) Has sediment or other pollutants discharging from the site reached State waters? **Off-site pollutant discharges are a violation of the permit.** If off site discharge has occurred, explain the discharge and the corrective actions in section 15 (Construction Site Assessment & Corrective Actions) or section 17 (General Notes).

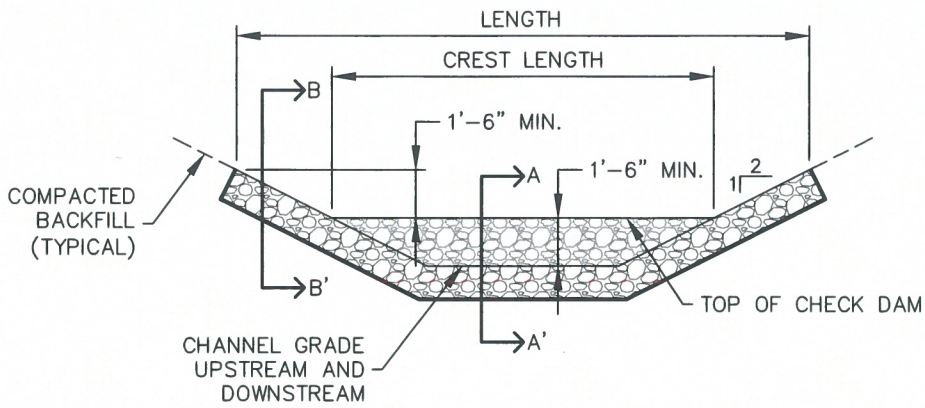

CHECK DAM ELEVATION VIEW

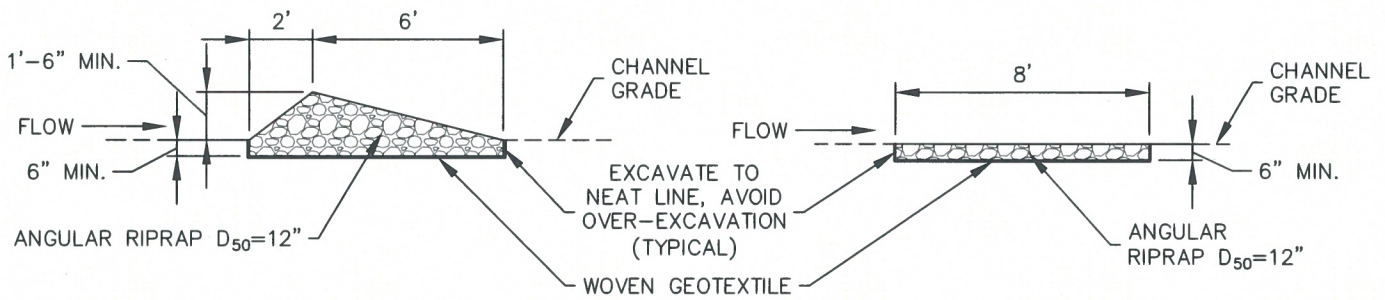

SECTION A-A'

SECTION B-B'

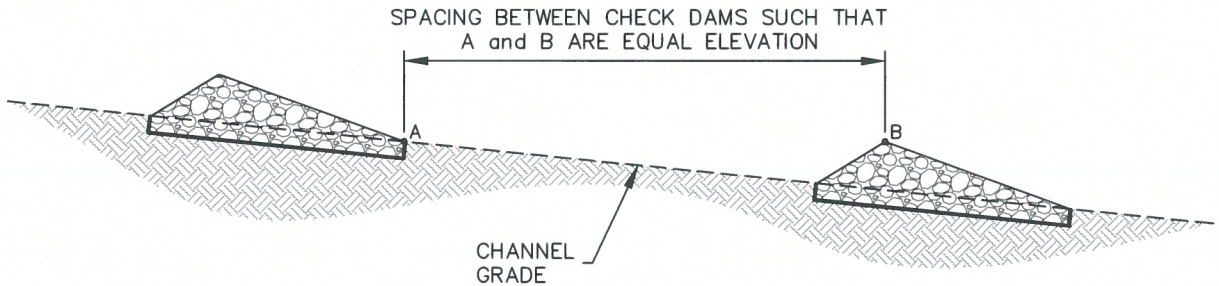

PROFILE

INSTALLATION NOTES

1. CHECK DAMS SHOULD BE INSTALLED BEFORE UPSTREAM LAND DISTURBING ACTIVITIES.
2. RIPRAP PAD SHOULD BE TRENCHED INTO GROUND BY A MINIMUM OF 6".

MAINTENANCE NOTES

1. FREQUENT OBSERVATIONS AND MAINTENANCE ARE NECESSARY TO MAINTAIN CONTROL MEASURES IN EFFECTIVE OPERATING CONDITION. INSPECTIONS AND CORRECTIVE MEASURES SHOULD BE DOCUMENTED THOROUGHLY.
2. ACCUMULATED SEDIMENT MUST BE REMOVED WHEN THE HEIGHT REACHES 1/2 THE HEIGHT OF THE CHECK DAM CREST.
3. CHECK DAMS MUST REMAIN UNTIL THE UPSTREAM DISTURBANCE AREA IS STABILIZED.
4. PERMANENTLY STABILIZE AREA AFTER CHECK DAMS ARE REMOVED IF REMOVAL IS REQUIRED.

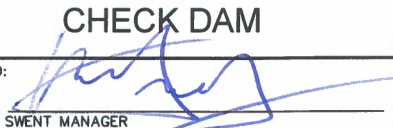

CHECK DAM		
APPROVED: 		
SWENT MANAGER		
ISSUED: 10/7/19	REVISED: 8/19/2020	DRAWING NO. 900-CD

- (17) General Notes: Indicate any additional notes that add detail to the inspection; this may include positive practices noted on the project.
- (18) Inspection Certification: In accordance with 208.03, required personnel shall sign to verify that they were in attendance.
- (19) Compliance Certification: After all corrections have been made, this signature must be completed in accordance with Part I.A.3.f of the CDPS-SCP.

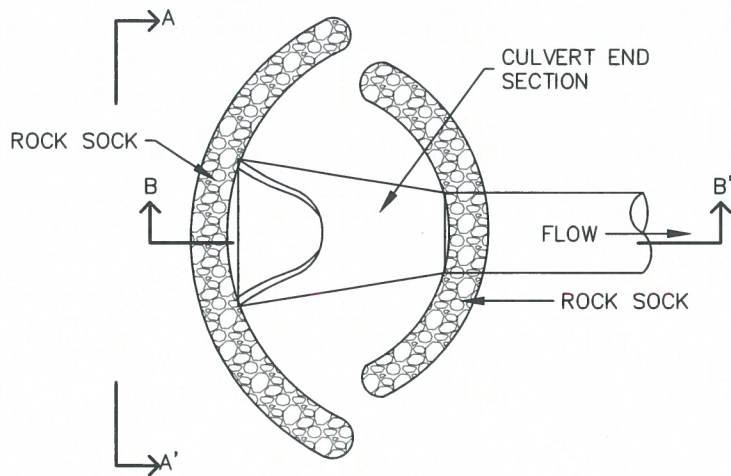

CULVERT INLET PROTECTION PLAN

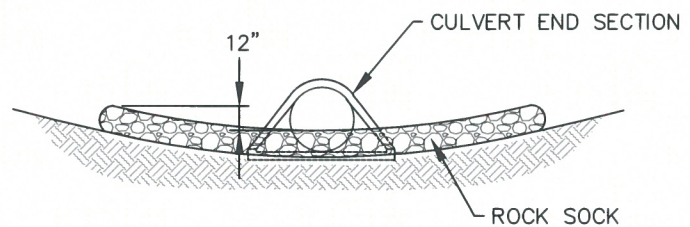

SECTION A-A'

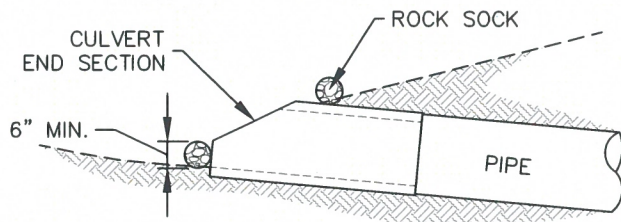

SECTION B-B'

INSTALLATION NOTES

1. SEE ROCK SOCK DETAIL.

MAINTENANCE NOTES

1. FREQUENT OBSERVATIONS AND MAINTENANCE ARE NECESSARY TO MAINTAIN CONTROL MEASURES IN EFFECTIVE OPERATING CONDITION. INSPECTIONS AND CORRECTIVE MEASURES SHOULD BE DOCUMENTED THOROUGHLY.
2. ACCUMULATED SEDIMENT UPSTREAM OF THE CULVERT SHALL BE REMOVED WHEN THE SEDIMENT DEPTH IS $\frac{1}{2}$ HEIGHT OF THE ROCK SOCK.
3. CULVERT INLET PROTECTION SHALL REMAIN UNTIL THE UPSTREAM AREA IS PERMANENTLY STABILIZED.

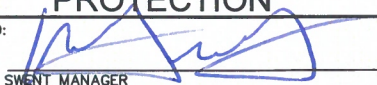

CULVERT INLET PROTECTION		
APPROVED: 		
SWENT MANAGER		
ISSUED: 10/7/19	REVISED: 8/19/2020	DRAWING NO. 900-CIP

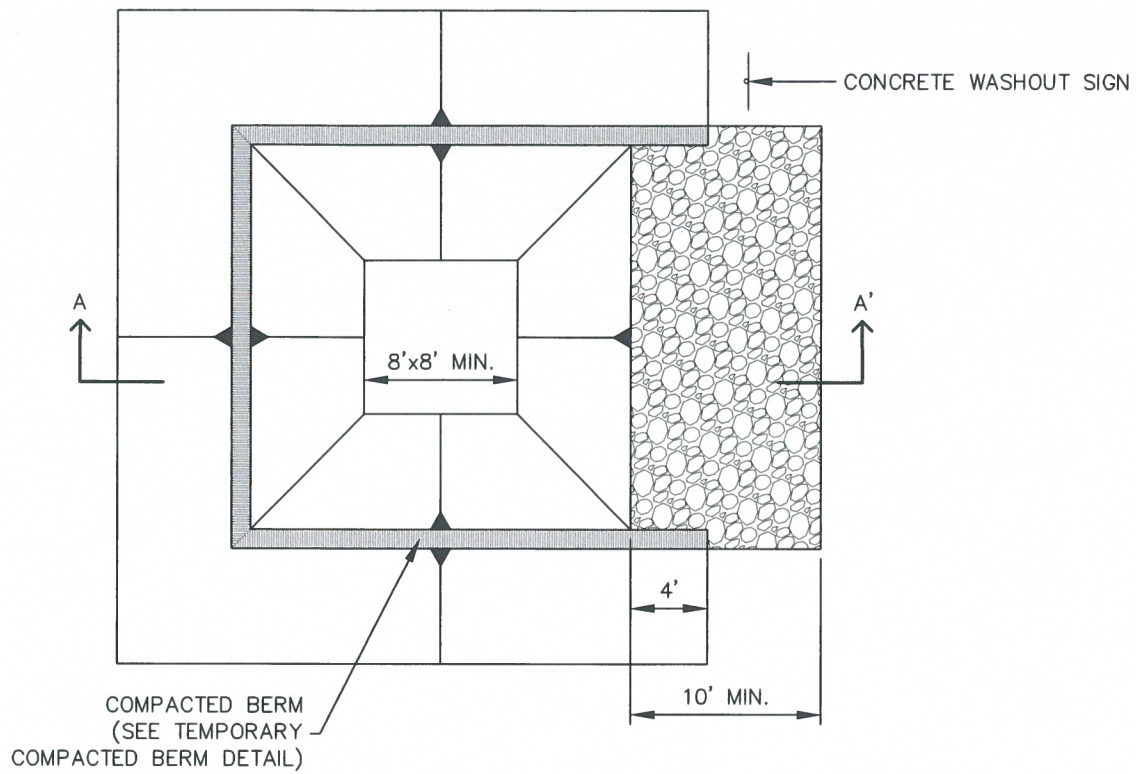

CONCRETE WASHOUT AREA PLAN

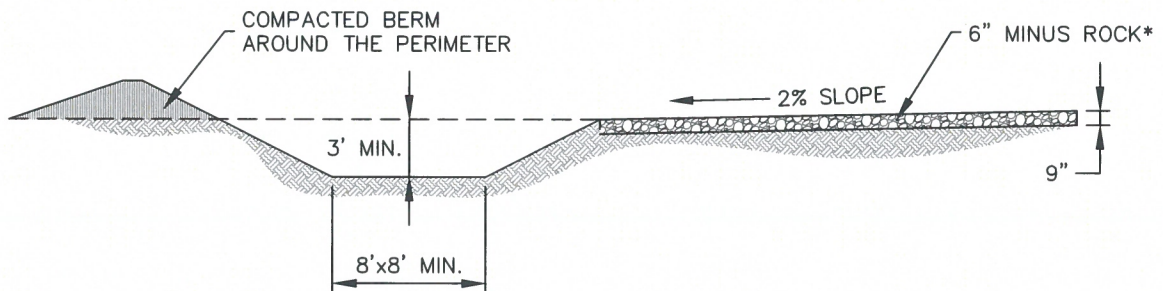

SECTION A-A'

*ROCK REQUIRED BASED ON
SITE CONDITIONS AT THE
DISCRETION OF THE GEC
INSPECTOR



**CONCRETE
WASHOUT AREA**

APPROVED:		
SWENT MANAGER		
ISSUED: 10/7/19	REVISED: 8/19/2020	DRAWING NO. 900-CWA-1

INSTALLATION NOTES

1. SEE PLAN VIEW FOR:
-LOCATION OF CONCRETE WASHOUT AREA
2. LOCATE AT LEAST 50' AWAY FROM STATE WATERS MEASURED HORIZONTALLY.
3. AN IMPERMEABLE LINER (16 MIL. MINIMUM THICKNESS) IS REQUIRED IF CONCRETE WASH AREA IS LOCATED WITHIN 400' OF STATE WATERS OR 1000' OF WELLS OR DRINKING WATER SOURCES.
4. DO NOT LOCATE IN AREAS WHERE SHALLOW GROUNDWATER MAY BE PRESENT.
5. THE CONCRETE WASH AREA SHALL BE INSTALLED PRIOR TO CONCRETE PLACEMENT ON SITE.
6. CONCRETE WASH AREA SHALL INCLUDE A FLAT SUBSURFACE PIT THAT IS AT LEAST 8' BY 8'.
7. BERM SURROUNDING SIDES AND BACK OF CONCRETE WASH AREA SHALL HAVE A MINIMUM HEIGHT OF 2 FEET.
8. CONCRETE WASH AREA ENTRANCE SHALL BE SLOPED 2% TOWARDS THE CONCRETE WASH AREA.
9. SIGNS SHALL BE PLACED AT THE CONCRETE WASH AREA.
10. USE EXCAVATED MATERIAL FOR PERIMETER BERM CONSTRUCTION.

MAINTENANCE NOTES

1. FREQUENT OBSERVATIONS AND MAINTENANCE ARE NECESSARY TO MAINTAIN CONTROL MEASURES IN EFFECTIVE OPERATING CONDITION. INSPECTIONS AND CORRECTIVE MEASURES SHOULD BE DOCUMENTED THOROUGHLY.
2. THE CONCRETE WASH AREA SHALL BE REPAIRED, CLEANED, OR ENLARGED AS NECESSARY TO MAINTAIN CAPACITY FOR CONCRETE WASTE. CONCRETE MATERIALS ACCUMULATED IN THE PIT SHALL BE REMOVED ONCE THE MATERIALS HAVE REACHED A DEPTH OF $\frac{2}{3}$ THE HEIGHT OF THE CONCRETE WASH AREA.
3. CONCRETE WASHOUT WATER, WASTED PIECES OF CONCRETE, AND ALL OTHER DEBRIS IN THE SUBSURFACE PIT SHALL BE TRANSPORTED FROM THE JOB SITE IN A WATER-TIGHT CONTAINER AND DISPOSED OF PROPERLY.
4. THE CONCRETE WASH AREA SHALL REMAIN IN PLACE UNTIL ALL CONCRETE FOR THE PROJECT IS PLACED.
5. PERMANENTLY STABILIZE AREA AFTER CONCRETE WASH AREA IS REMOVED.

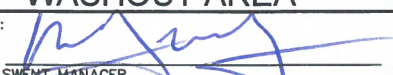

CONCRETE WASHOUT AREA		
APPROVED: 		
SWEMT MANAGER		
ISSUED: 10/7/19	REVISED: 8/19/2020	DRAWING NO. 900-CWA-2

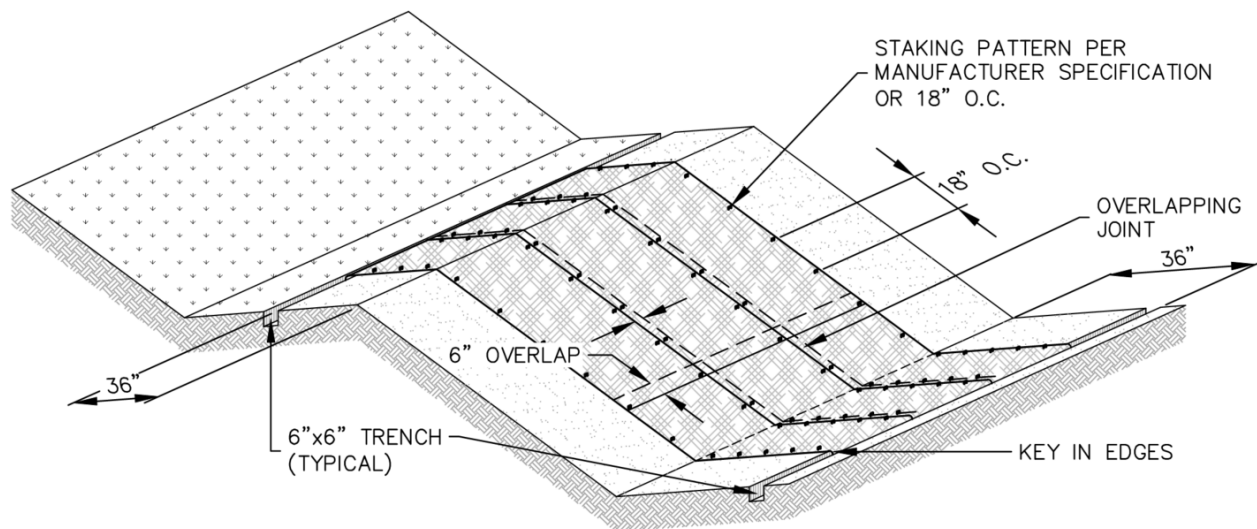

EROSION CONTROL BLANKET

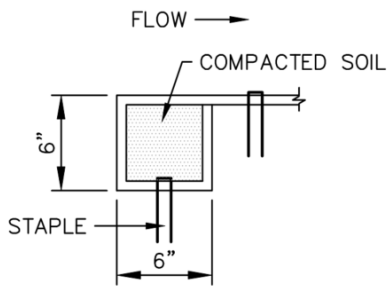

PERIMETER ANCHOR TRENCH

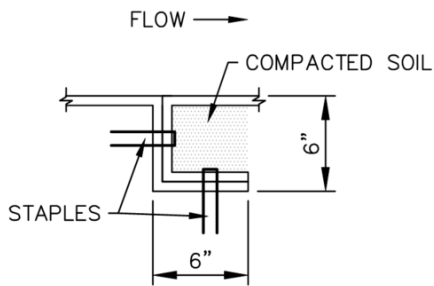

JOINT ANCHOR TRENCH

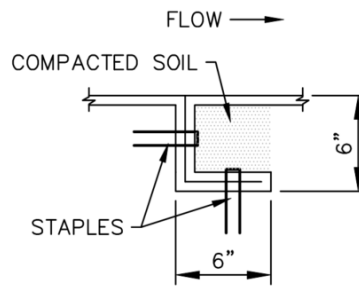

INTERMEDIATE CHECK SLOT

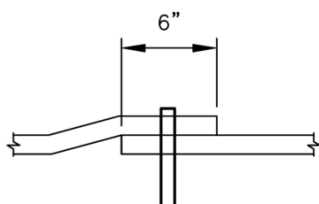

OVERLAPPING JOINT

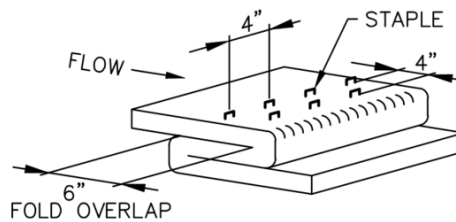

STAPLE CHECK
TO BE USED ON SLOPE EVERY 15 FEET

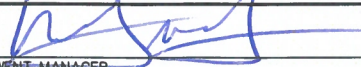

EROSION CONTROL BLANKET

APPROVED: 
SWENT MANAGER

ISSUED: 10/7/19	REVISED: 8/19/2020	DRAWING NO. 900-ECB-1
--------------------	-----------------------	--------------------------

INSTALLATION NOTES

1. 100% NATURAL AND BIODEGRADABLE MATERIALS ARE REQUIRED FOR EROSION CONTROL BLANKETS. TRM PRODUCTS MAY BE USED WHERE APPROPRIATE AS DESIGNATED BY THE ENGINEER.
2. IN AREAS WHERE EROSION CONTROL BLANKETS ARE SHOWN ON THE PLANS, THE PERMITTEE SHALL PLACE TOPSOIL AND PERFORM FINAL GRADING, SURFACE PREPARATION, AND SEEDING AND MULCHING. SUBGRADE SHALL BE SMOOTH AND MOIST PRIOR TO EROSION CONTROL BLANKET INSTALLATION, AND THE EROSION CONTROL BLANKET SHALL BE IN FULL CONTACT WITH THE SUBGRADE. NO GAPS OR VOIDS SHALL EXIST UNDER THE BLANKET.
3. PERIMETER ANCHOR TRENCH SHALL BE USED ALONG THE OUTSIDE PERIMETER OF ALL BLANKET AREAS.
4. JOINT ANCHOR TRENCH SHALL BE USED TO JOIN ROLLS OF EROSION CONTROL BLANKETS TOGETHER (LONGITUDINALLY AND TRANSVERSELY) FOR ALL EROSION CONTROL BLANKETS.
5. INTERMEDIATE CHECK SLOT OR STAPLE CHECK SHALL BE INSTALLED EVERY 15' DOWN SLOPES. IN DRAINAGEWAYS, INSTALL CHECK SLOTS EVERY 25' PERPENDICULAR TO FLOW DIRECTION.
6. OVERLAPPING JOINT DETAIL SHALL BE USED TO JOIN ROLLS OF EROSION CONTROL BLANKETS TOGETHER FOR EROSION CONTROL BLANKETS ON SLOPES.
7. MATERIAL SPECIFICATIONS OF EROSION CONTROL BLANKETS SHALL CONFORM TO TABLE ECB-1.
8. ANY AREAS OF SEEDING AND MULCHING DISTURBED IN THE PROCESS OF INSTALLING EROSION CONTROL BLANKETS SHALL BE RESEEDED AND MULCHED.
9. STRAW EROSION CONTROL BLANKETS SHALL NOT BE USED WITHIN STREAMS AND DRAINAGE CHANNELS.
10. COMPACT ALL TRENCHES.

MAINTENANCE NOTES

1. FREQUENT OBSERVATIONS AND MAINTENANCE ARE NECESSARY TO MAINTAIN CONTROL MEASURES IN EFFECTIVE OPERATING CONDITION. INSPECTIONS AND CORRECTIVE MEASURES SHOULD BE DOCUMENTED THOROUGHLY.
2. EROSION CONTROL BLANKETS SHALL BE LEFT IN PLACE TO EVENTUALLY BIODEGRADE. TRM MUST BE REMOVED AT THE DISCRETION OF THE GEC INSPECTOR.
3. ANY EROSION CONTROL BLANKET PULLED OUT, TORN, OR OTHERWISE DAMAGED SHALL BE REPAIRED OR REINSTALLED. ANY SUBGRADE AREAS BELOW GEOTEXTILE THAT HAVE ERODED TO CREATE A VOID UNDER THE BLANKET, OR THAT REMAIN DEVOID OF GRASS SHALL BE REPAIRED, RESEEDED AND MULCHED AND THE EROSION CONTROL BLANKET REINSTALLED.

TABLE ECB-1, EROSION CONTROL BLANKET MATERIAL SPECIFICATIONS

TYPE	COCONUT CONTENT	STRAW CONTENT	EXCELSIOR CONTENT	RECOMMENDED NETTING
STRAW	-	100%	-	DOUBLE/NATURAL
STRAW-COCONUT	30% MIN.	70% MAX.	-	DOUBLE/NATURAL
COCONUT	100%	-	-	DOUBLE/NATURAL
EXCELSIOR	-	-	100%	DOUBLE/NATURAL



EROSION CONTROL BLANKET

APPROVED: 

SWENT MANAGER

ISSUED: 10/7/19	REVISED: 8/19/2020	DRAWING NO. 900-ECB-2
--------------------	-----------------------	--------------------------

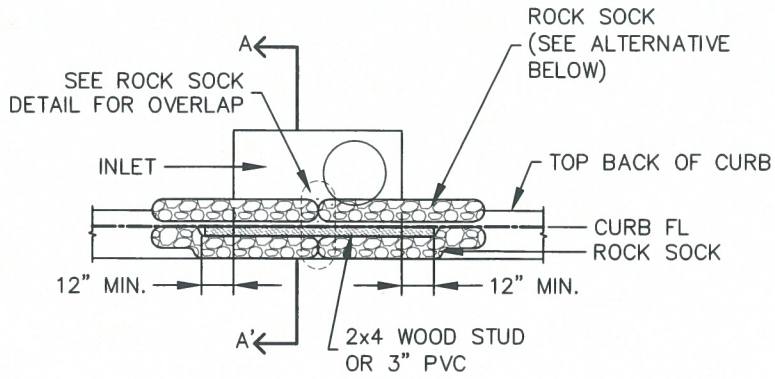

CURB INLET PROTECTION PLAN

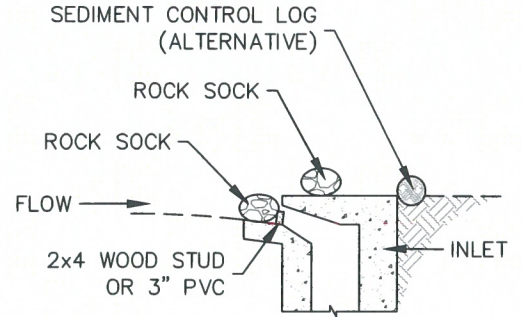

SECTION A-A'

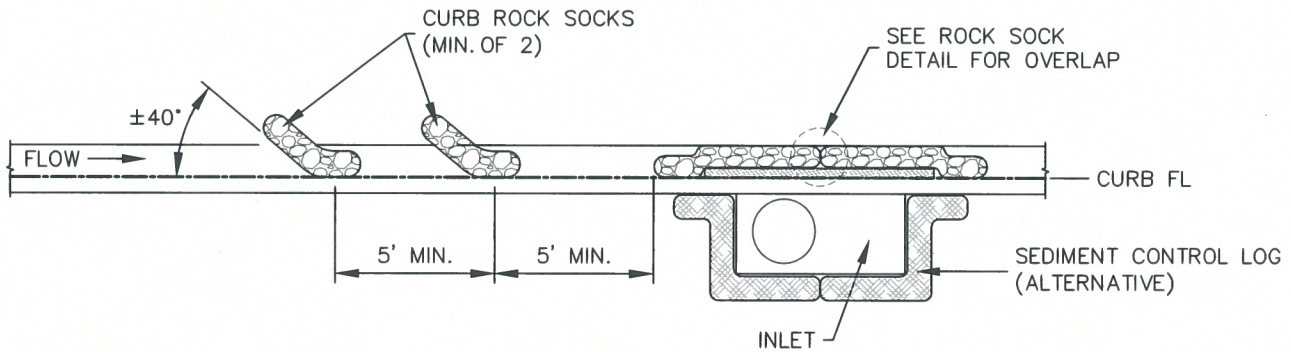

CURB ROCK SOCKS UPSTREAM OF INLET PROTECTION

INSTALLATION NOTES

1. SEE ROCK SOCK DETAIL FOR INSTALLATION REQUIREMENTS.
2. PLACEMENT OF THE ROCK SOCK SHALL BE APPROXIMATELY 40 DEGREES FROM THE CURB.
3. ROCK SOCKS ARE TO BE FLUSH WITH THE CURB AND SPACED A MINIMUM OF 5' APART.
4. AT LEAST TWO CURB ROCK SOCKS IN SERIES ARE REQUIRED UPSTREAM OF ON-GRADE INLETS.
5. ADDITIONAL ROCK SOCKS MAY BE REQUIRED AT GEC INSPECTOR'S DISCRETION.

MAINTENANCE NOTES

1. FREQUENT OBSERVATIONS AND MAINTENANCE ARE NECESSARY TO MAINTAIN CONTROL MEASURES IN EFFECTIVE OPERATING CONDITION. INSPECTIONS AND CORRECTIVE MEASURES SHOULD BE DOCUMENTED THOROUGHLY.
2. ACCUMULATED SEDIMENT MUST BE REMOVED WHEN THE HEIGHT REACHES 1/2 OF THE DESIGN DEPTH OF THE INLET BARRIER.
3. ROCK SOCKS MUST REMAIN UNTIL THE UPSTREAM DISTURBANCE AREA IS STABILIZED.
4. PERMANENTLY STABILIZE AREA BEHIND INLET AFTER ROCK SOCKS ARE REMOVED WHEN REMOVAL IS APPROPRIATE.

IP-1



ON-GRADE INLET PROTECTION

APPROVED: *[Signature]*
SWENT MANAGER

ISSUED: 10/7/19	REVISED: 8/19/2020	DRAWING NO. 900-IP-1
--------------------	-----------------------	-------------------------

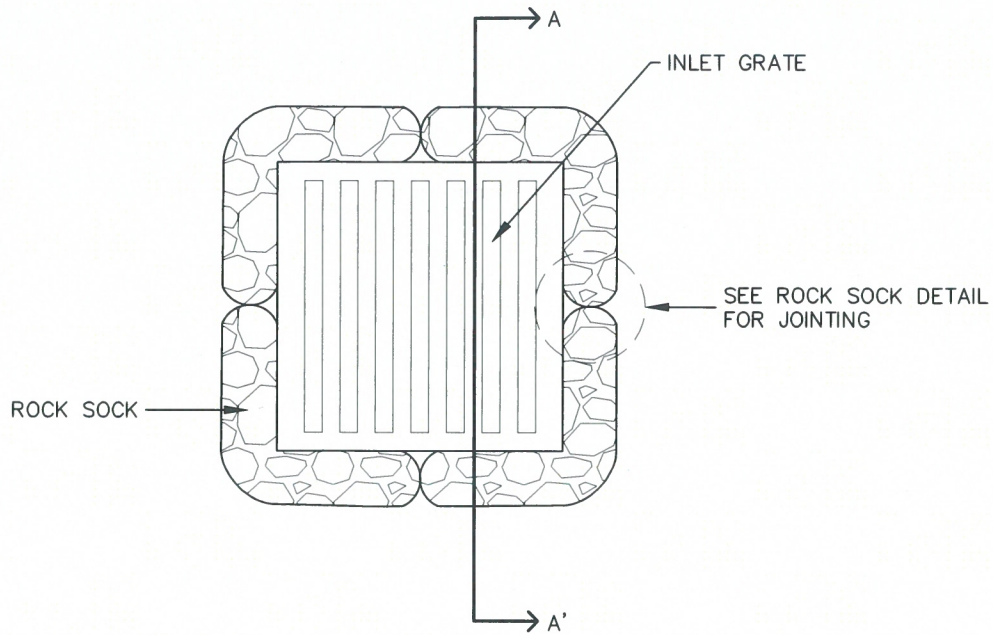

ROCK SOCK SUMP INLET PROTECTION PLAN

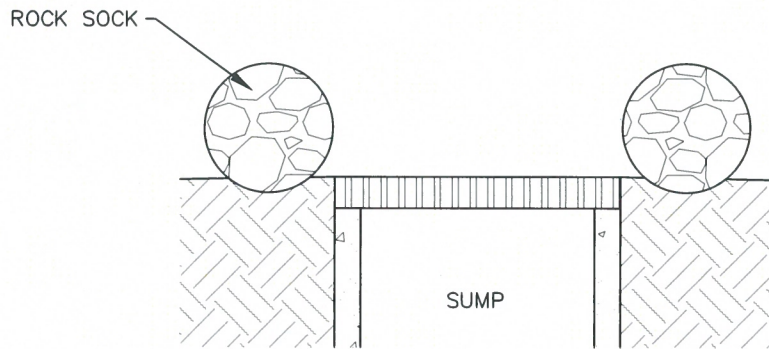

SECTION A-A'

INSTALLATION NOTES

1. SEE ROCK SOCK DETAIL FOR INSTALLATION REQUIREMENTS.
2. SEDIMENT CONTROL LOGS MAY BE USED IN PLACE OF ROCK SOCKS IN PERVIOUS AREAS. INSTALL PER SEDIMENT CONTROL LOG DETAIL
3. CONTROL MEASURES MUST BE WRAPPED AROUND INLET AS TIGHTLY AS POSSIBLE.

MAINTENANCE NOTES

1. FREQUENT OBSERVATIONS AND MAINTENANCE ARE NECESSARY TO MAINTAIN CONTROL MEASURES IN EFFECTIVE OPERATING CONDITION. INSPECTIONS AND CORRECTIVE MEASURES SHOULD BE DOCUMENTED THOROUGHLY.
2. ACCUMULATED SEDIMENT MUST BE REMOVED WHEN THE HEIGHT REACHES 1/2 OF THE DESIGN DEPTH OF THE INLET BARRIER.
3. ROCK SOCKS MUST REMAIN UNTIL THE UPSTREAM DISTURBANCE AREA IS STABILIZED.
4. PERMANENTLY STABILIZE AREA AROUND INLET AFTER ROCK SOCKS ARE REMOVED WHEN REMOVAL IS APPROPRIATE.

IP-2

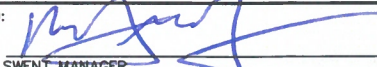

SUMP INLET PROTECTION

APPROVED: 
SWENT MANAGER

ISSUED: 10/7/19	REVISED: 8/19/2020	DRAWING NO. 900-IP-2
--------------------	-----------------------	-------------------------

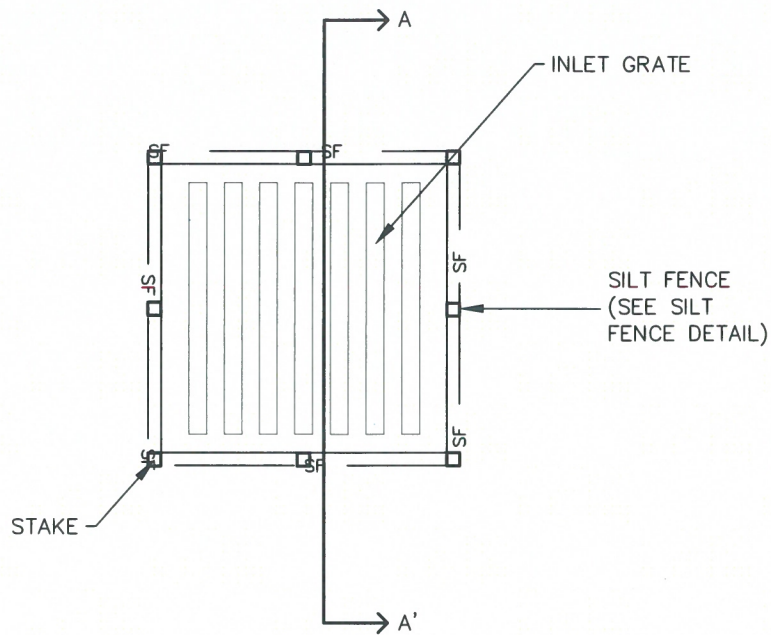

SILT FENCE SUMP INLET PROTECTION PLAN

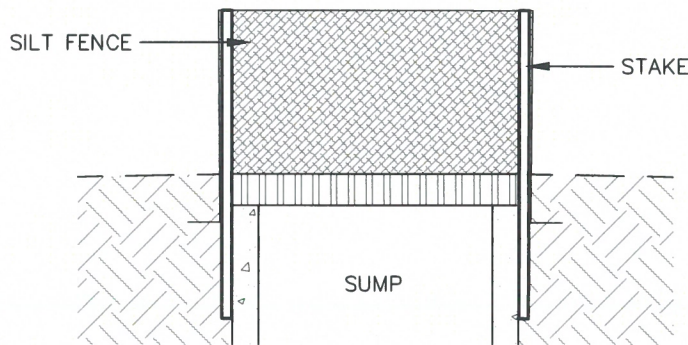

SECTION A-A'

INSTALLATION NOTES

1. SEE SILT FENCE DETAIL FOR INSTALLATION REQUIREMENTS.
2. POSTS SHALL BE PLACED AT EACH CORNER OF THE INLET AND AROUND THE EDGES AT A MAXIMUM SPACING OF THREE FEET.
3. SILT FENCE FABRIC SHOULD HAVE A FLOW RATE IN EXCESS OF 30 GALLONS PER MINUTE PER SQUARE YARD SO AS TO ALLOW SOME WATER FLOW AND NOT DAM THE WATER. STANDARD, LOW-FLOW SILT FENCE FABRIC WILL NOT BE ALLOWED.

MAINTENANCE NOTES

1. FREQUENT OBSERVATIONS AND MAINTENANCE ARE NECESSARY TO MAINTAIN CONTROL MEASURES IN EFFECTIVE OPERATING CONDITION. INSPECTIONS AND CORRECTIVE MEASURES SHOULD BE DOCUMENTED THOROUGHLY.
2. ACCUMULATED SEDIMENT MUST BE REMOVED WHEN THE HEIGHT REACHES 1/2 OF THE DESIGN DEPTH OF THE INLET BARRIER.
3. SILT FENCE MUST REMAIN UNTIL THE UPSTREAM DISTURBANCE AREA IS STABILIZED.
4. PERMANENTLY STABILIZE AREA AROUND INLET AFTER SILT FENCE IS REMOVED WHEN REMOVAL IS APPROPRIATE.

IP-3

	SUMP INLET PROTECTION		
	APPROVED:		
	SWENT MANAGER		
ISSUED: 10/7/19	REVISED: 8/19/2020	DRAWING NO. 900-IP-3	

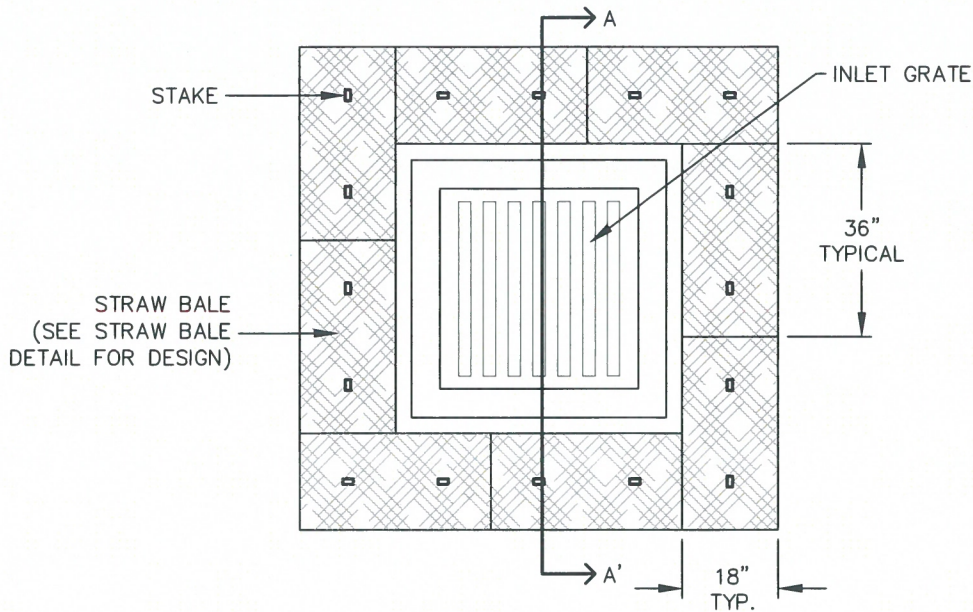

STRAW BALE SUMP INLET PROTECTION PLAN

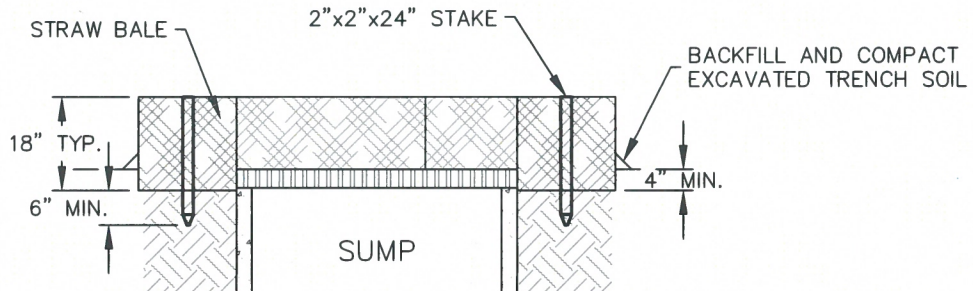

SECTION A-A'

INSTALLATION NOTES

1. BALES SHALL BE PLACED IN A SINGLE ROW AROUND THE INLET WITH THE ENDS OF THE BALES TIGHTLY ABUTTING ONE ANOTHER.
2. STRAW BALES SHALL CONSIST OF CERTIFIED WEED FREE STRAW OR HAY. LOCAL JURISDICTIONS MAY REQUIRE PROOF THAT BALES ARE WEED FREE.
3. STRAW BALES SHALL CONSIST OF APPROXIMATELY 5 CUBIC FEET OF STRAW OR HAY AND WEIGH NOT LESS THAN 35 POUNDS.
4. STRAW BALE DIMENSIONS SHALL BE APPROXIMATELY 36"x18"x18".
5. A UNIFORM ANCHOR TRENCH SHALL BE EXCAVATED TO A DEPTH OF 4". STRAW BALES SHALL BE PACED SO THAT THE BINDING TWINE IS ENCOMPASSING THE VERTICAL SIDES OF THE BALE(S).
6. TWO (2) WOODEN STAKES SHALL BE USED TO HOLD EACH BALE IN PLACE. WOODEN STAKED SHALL BE 2"x2"x24 (MIN.)". WOODEN STAKES SHALL BE DRIVEN A MINIMUM OF 6" INTO THE GROUND.

MAINTENANCE NOTES

1. FREQUENT OBSERVATIONS AND MAINTENANCE ARE NECESSARY TO MAINTAIN CONTROL MEASURES IN EFFECTIVE OPERATING CONDITION. INSPECTIONS AND CORRECTIVE MEASURES SHOULD BE DOCUMENTED THOROUGHLY.
2. ACCUMULATED SEDIMENT MUST BE REMOVED WHEN THE HEIGHT REACHES ½ OF THE DESIGN DEPTH OF THE INLET BARRIER.
3. STRAW BALES MUST REMAIN UNTIL THE UPSTREAM DISTURBANCE AREA IS STABILIZED.
4. PERMANENTLY STABILIZE AREA AROUND INLET AFTER STRAW BALES ARE REMOVED WHEN REMOVAL IS APPROPRIATE.
5. STRAW BALES SHALL BE REPLACED IF THEY BECOME HEAVILY SOILED, ROTTEN OR DAMAGED BEYOND REPAIR.

IP-4



SUMP INLET PROTECTION

APPROVED: 
SWENT MANAGER

ISSUED: 10/7/19	REVISED: 8/19/2020	DRAWING NO. 900-IP-4
--------------------	-----------------------	-------------------------

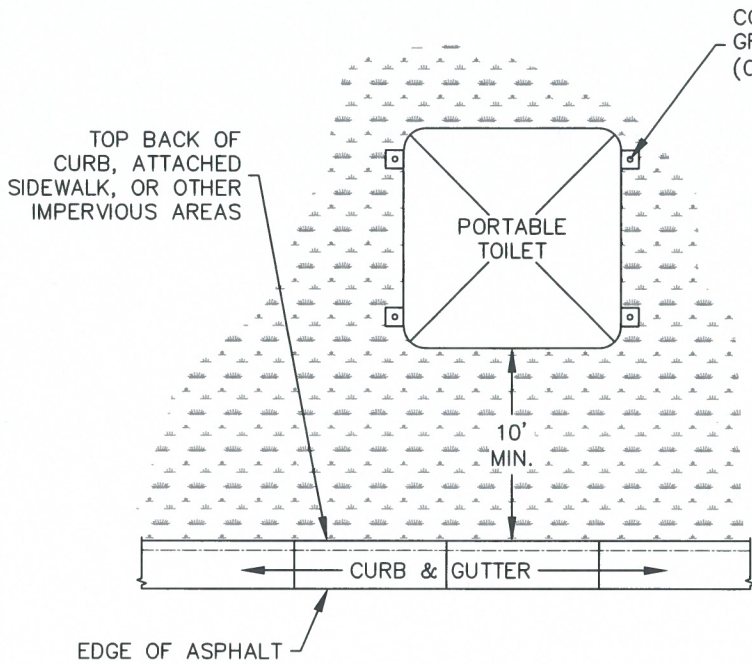

PORTABLE TOILET PLAN

CONTRACTOR SHALL ANCHOR PORTABLE TOILET TO THE GROUND, AT A MINIMUM OF TWO OPPOSING CORNERS (ON A DIAGONAL) USING U-SHAPED REBAR STAKES

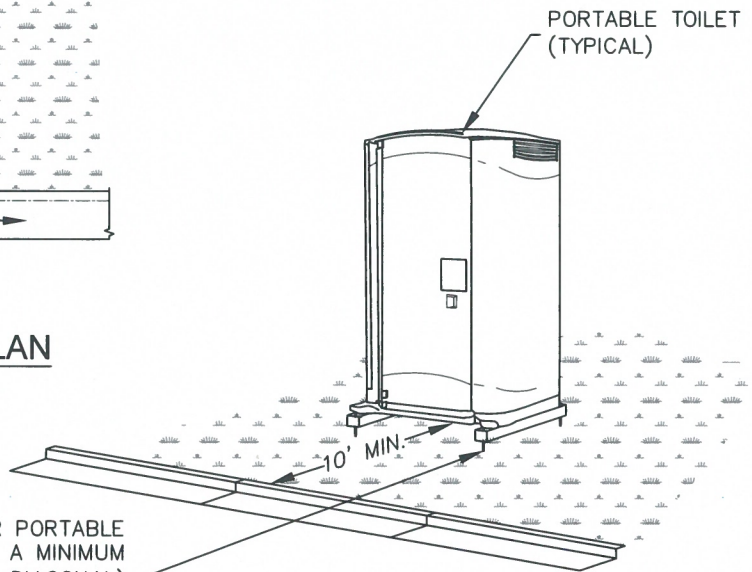

ISOMETRIC

CONTRACTOR SHALL ANCHOR PORTABLE TOILET TO THE GROUND, AT A MINIMUM OF TWO OPPOSING CORNERS (ON A DIAGONAL) USING U-SHAPED REBAR STAKES OR OTHER EFFECTIVE ANCHORING

INSTALLATION NOTES

1. PORTABLE TOILETS SHALL BE PLACED A MINIMUM OF 10 FEET BEHIND ALL CURBS, SIDEWALKS, AND OTHER IMPERVIOUS AREAS; 50 FEET FROM STORM INLETS, AND 100 FEET FROM WATERWAYS.
2. PORTABLE TOILETS IN THE RIGHT-OF-WAY ARE REQUIRED TO BE PLACED ON MOBILE TRAILERS AND MUST BE ANCHORED OR WEIGHTED DOWN. PORTABLE TOILETS MAY BE INSTALLED IN ACCORDANCE WITH NOTE #1 IN STAGING AREAS/YARDS.
3. PORTABLE TOILETS SHALL BE SECURELY ANCHORED TO THE GROUND USING U-SHAPED REBAR STAKES, OR OTHER EFFECTIVE ANCHORING.
4. ANCHORING SHALL BE POSITIONED ON AT LEAST TWO OPPOSING (DIAGONAL) CORNERS.
5. TOILET CONTAINMENT PANS MAY BE USED IN PLACE OF A TRAILER AT THE GEC INSPECTOR'S DISCRETION. TOILET CONTAINMENT PANS MUST BE ANCHORED IN PLACE AND MUST NOT BE USED WITHIN THE CITY R.O.W.



MAINTENANCE NOTES

1. FREQUENT OBSERVATIONS AND MAINTENANCE ARE NECESSARY TO MAINTAIN CONTROL MEASURES IN EFFECTIVE OPERATING CONDITION. INSPECTIONS AND CORRECTIVE MEASURES SHOULD BE DOCUMENTED THOROUGHLY.
2. PORTABLE TOILETS SHALL BE SERVICED AT THE NECESSARY INTERVALS TO ELIMINATE THE POSSIBILITY OF OVERFLOW.
3. WHEN THE PORTABLE TOILETS ARE REMOVED, ANY DISTURBED AREAS ASSOCIATED WITH THE INSTALLATION, MAINTENANCE, AND/OR REMOVAL OF THE TOILETS MUST BE PERMANENTLY STABILIZED.

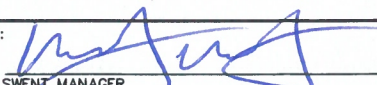
PORTABLE TOILET		
APPROVED: 		
SWENT MANAGER		
ISSUED: 2/19/19	REVISED: 8/19/2020	DRAWING NO. 900-PTM

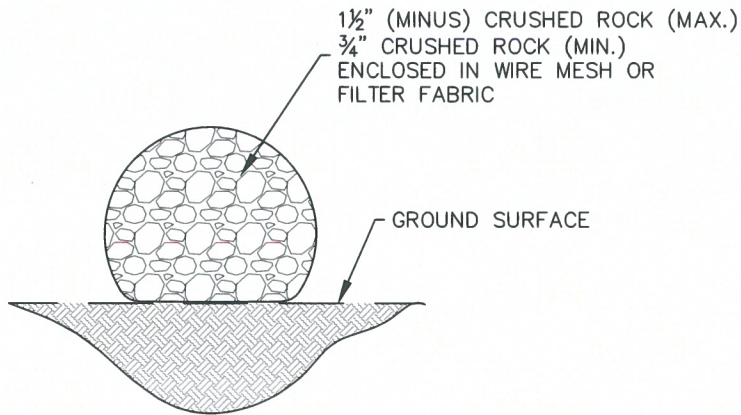

ROCK SOCK SECTION

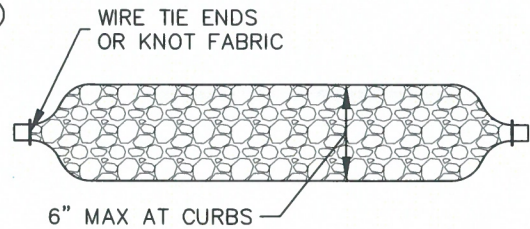

ROCK SOCK PLAN

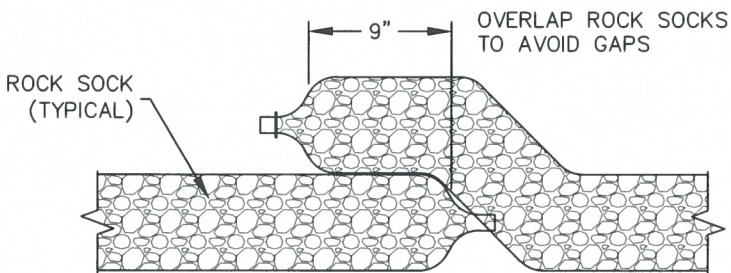

ROCK SOCK OVERLAP

GRADATION TABLE

	MASS PERCENT PASSING SQUARE MESH SIEVES
	No. 4
2"	100
1 1/2"	90-100
1"	20-55
3/4"	0-15
3/8"	0-5

MATCHES SPECIFICATIONS FOR
No. 4 COARSE AGGREGATE FOR
CONCRETE PER AASHTO M-43.
ALL ROCK SHALL BE FRACTURED
FACE, ALL SIDES

INSTALLATION NOTES

1. CRUSHED ROCK SHALL BE BETWEEN MAX. 1 1/2" (MINUS) IN SIZE WITH A FRACTURED FACE (ALL SIDES) AND SHALL COMPLY WITH GRADATION SHOWN ON THIS SHEET AND MIN. 3/4" CRUSHED ROCK.
2. WIRE MESH SHALL HAVE OPENINGS SMALLER THAN THE SMALLEST SIZE ROCK.
3. WIRE MESH SHALL BE SECURED USING 'HOG RINGS' OR WIRE TIES AT 6" CENTERS ALONG ALL JOINTS AND AT 2" CENTERS ON ENDS OF SOCKS.

MAINTENANCE NOTES

1. FREQUENT OBSERVATIONS AND MAINTENANCE ARE NECESSARY TO MAINTAIN CONTROL MEASURES IN EFFECTIVE OPERATING CONDITION. INSPECTIONS AND CORRECTIVE MEASURES SHOULD BE DOCUMENTED THOROUGHLY.
2. ROCK SOCKS SHALL BE REPLACED IF THEY BECOME HEAVILY SOILED OR DAMAGED BEYOND REPAIR.
3. ACCUMULATED SEDIMENT SHALL BE REMOVED WHEN THE DEPTH REACHES 1/2 OF THE HEIGHT OF THE ROCK SOCK.
4. ROCK SOCKS ARE TO REMAIN IN PLACE UNTIL DISTURBED AREA IS STABILIZED.
5. PERMANENTLY STABILIZE AREA AFTER ROCK SOCKS HAVE BEEN REMOVED.

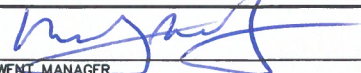

ROCK SOCK

APPROVED: 
SWEMT MANAGER

ISSUED: 10/7/19	REVISED: 8/19/2020	DRAWING NO. 900-RS
--------------------	-----------------------	-----------------------

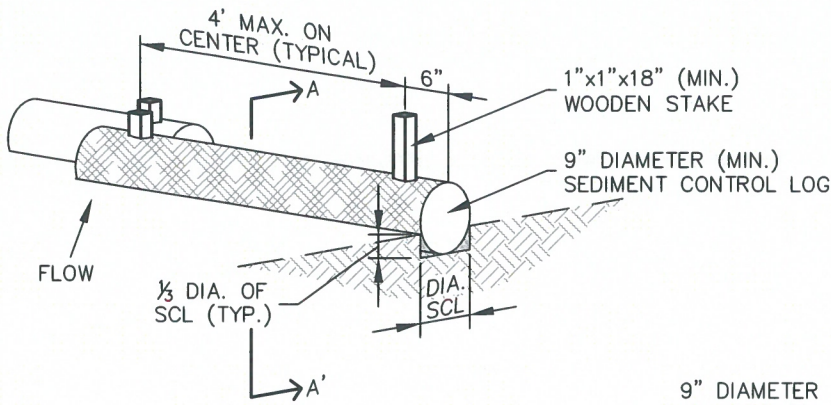

SEDIMENT CONTROL LOG

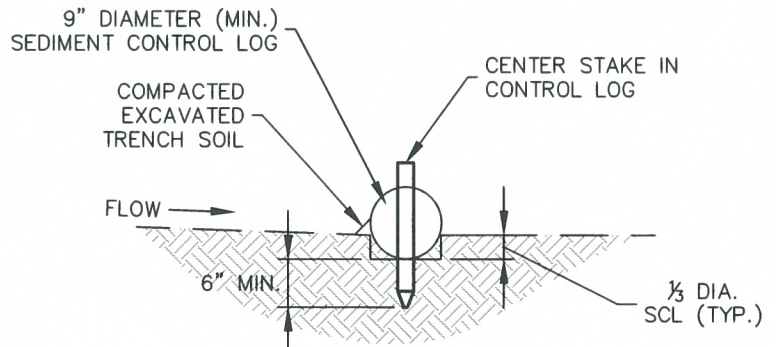

SECTION A-A'

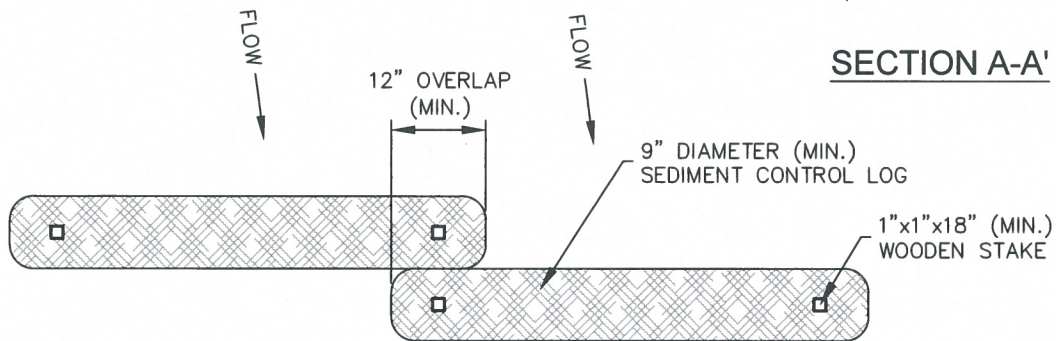

SEDIMENT CONTROL LOG JOINTS

INSTALLATION NOTES

1. ALL SEDIMENT CONTROL LOGS MUST BE EMBEDDED TO $\frac{1}{3}$ OF THE HEIGHT OF THE LOG
2. LARGER DIAMETER SEDIMENT CONTROL LOGS NEED TO BE EMBEDDED DEEPER.
3. PLACE SEDIMENT CONTROL LOG AGAINST SIDEWALK OR BACK OF CURB WHEN ADJACENT TO THESE FEATURES.
4. SEDIMENT CONTROL LOGS SHALL CONSIST OF STRAW, COMPOST, EXCELSIOR OR COCONUT FIBER, AND SHALL BE FREE FROM ANY NOXIOUS WEED SEEDS OR DEFECTS INCLUDING RIPS, HOLES AND OBVIOUS WEAR.
5. IF USING AS SLOPE PROTECTION, INSTALL SEDIMENT CONTROL LOGS ALONG THE CONTOUR.

MAINTENANCE NOTES

1. FREQUENT OBSERVATIONS AND MAINTENANCE ARE NECESSARY TO MAINTAIN CONTROL MEASURES IN EFFECTIVE OPERATING CONDITION. INSPECTIONS AND CORRECTIVE MEASURES SHOULD BE DOCUMENTED THOROUGHLY.
2. ACCUMULATED SEDIMENT MUST BE REMOVED WHEN THE HEIGHT REACHES $\frac{1}{2}$ OF THE HEIGHT OF THE SEDIMENT CONTROL LOG.
3. PERMANENTLY STABILIZE AREA AFTER SEDIMENT CONTROL LOGS HAVE BEEN REMOVED.

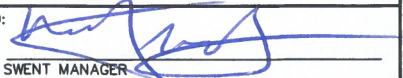

SEDIMENT CONTROL LOGS

APPROVED: 
SWENT MANAGER

ISSUED: 10/7/19	REVISED: 8/19/2020	DRAWING NO. 900-SCL
--------------------	-----------------------	------------------------

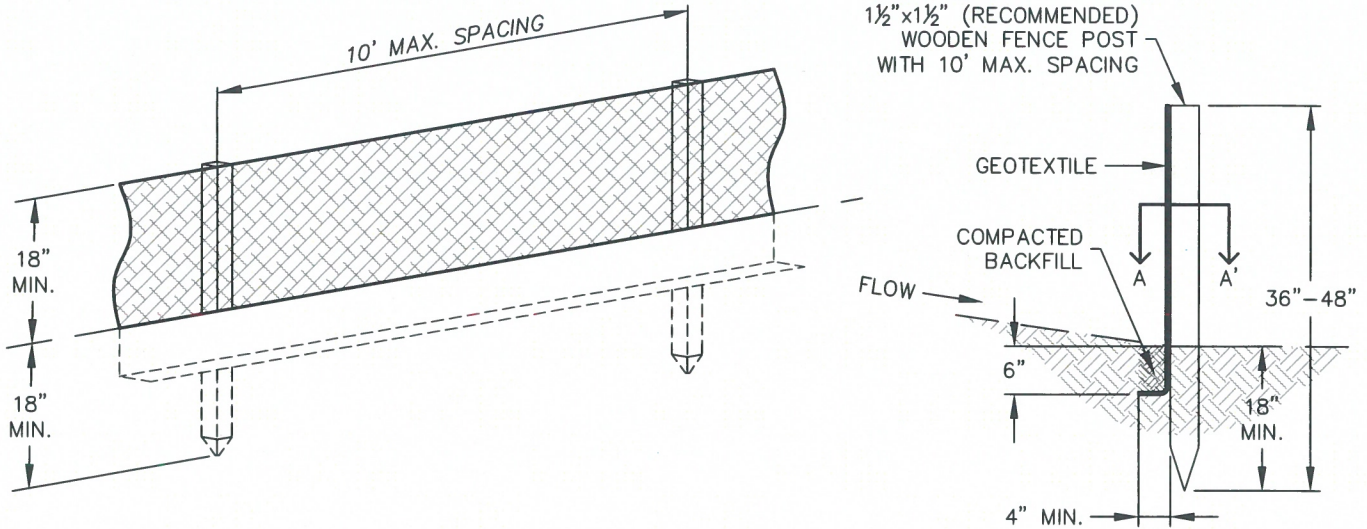

SILT FENCE

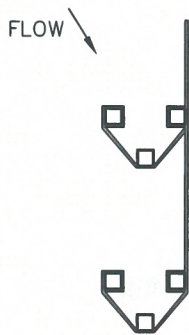

J-HOOK INSTALLATION

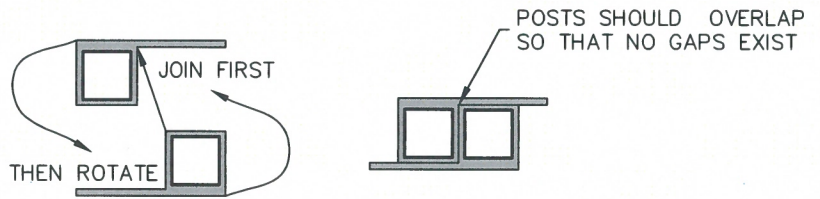

SECTION A-A'

INSTALLATION NOTES

1. SILT FENCE MUST BE PLACED ON A FLAT SURFACE 2'-5' AWAY FROM TOE OF THE SLOPE TO ALLOW FOR PONDING AND DEPOSITION.
2. COMPACT THE TRENCH USING A JUMPING JACK OR WHEEL ROLLING TO THE POINT THAT THE FENCE RESISTS BEING PULLED OUT OF THE GROUND BY HAND.
3. SILT FENCE SHALL BE TAUT WITH NO SAGS AFTER IT HAS BEEN ANCHORED.
4. FABRIC SHALL BE ATTACHED TO POSTS WITH 1" HEAVY DUTY STAPLES OR 1" NAILS. THESE SHOULD BE PLACED VERTICALLY DOWN THE POST, 3" APART.
5. THE PREFERRED INSTALLATION METHOD USES A TRENCHER OR SILT FENCE INSTALLATION DEVICE.
6. INSTALL SILT FENCE ALONG THE CONTOUR OF THE SLOPES OR IN A MANNER TO AVOID CREATING CONCENTRATED FLOW (SUCH AS A "J-HOOK" INSTALLATION).

MAINTENANCE NOTES

1. FREQUENT OBSERVATIONS AND MAINTENANCE ARE NECESSARY TO MAINTAIN CONTROL MEASURES IN EFFECTIVE OPERATING CONDITION. INSPECTIONS AND CORRECTIVE MEASURES SHOULD BE DOCUMENTED THOROUGHLY.
2. ACCUMULATED SEDIMENT MUST BE REMOVED WHEN THE HEIGHT REACHES 1/2 OF THE DESIGN HEIGHT OF THE SILT FENCE.
3. SILT FENCE MUST REMAIN UNTIL THE UPSTREAM DISTURBANCE AREA IS STABILIZED.
4. PERMANENTLY STABILIZE AREA AFTER SILT FENCE IS REMOVED.

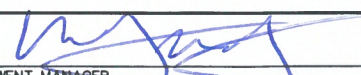

SILT FENCE		
APPROVED: 		
SWENT MANAGER		
ISSUED: 10/7/19	REVISED: 8/19/2020	DRAWING NO. 900-SF

SEEDING & MULCHING

ALL SOIL TESTING, SOILS AMENDMENT AND FERTILIZER DOCUMENTATION, AND SEED LOAD AND BAG TICKETS MUST BE ADDED TO THE CSWMP.

SOIL PREPARATION

1. IN AREAS TO BE SEEDED, THE UPPER 6 INCHES OF THE SOIL MUST NOT BE HEAVILY COMPACTED, AND SHOULD BE IN FRIABLE CONDITION. LESS THAN 85% STANDARD PROCTOR DENSITY IS ACCEPTABLE. AREAS OF COMPACTION OR GENERAL CONSTRUCTION ACTIVITY MUST BE SCARIFIED TO A DEPTH OF 6 TO 12 INCHES PRIOR TO SPREADING TOPSOIL TO BREAK UP COMPACTED LAYERS AND PROVIDE A BLENDING ZONE BETWEEN DIFFERENT SOIL LAYERS.
2. AREAS TO BE PLANTED SHALL HAVE AT LEAST 4 INCHES OF TOPSOIL SUITABLE TO SUPPORT PLANT GROWTH.
3. THE CITY RECOMMENDS THAT EXISTING AND/OR IMPORTED TOPSOIL BE TESTED TO IDENTIFY SOIL DEFICIENCIES AND ANY SOIL AMENDMENTS NECESSARY TO ADDRESS THESE DEFICIENCIES. SOIL AMENDMENTS AND/OR FERTILIZERS SHOULD BE ADDED TO CORRECT TOPSOIL DEFICIENCIES BASED ON SOIL TESTING RESULTS.
4. TOPSOIL SHALL BE PROTECTED DURING THE CONSTRUCTION PERIOD TO RETAIN ITS STRUCTURE AVOID COMPACTION, AND TO PREVENT EROSION AND CONTAMINATION. STRIPPED TOPSOIL MUST BE STORED IN AN AREA AWAY FROM MACHINERY AND CONSTRUCTION OPERATIONS, AND CARE MUST BE TAKEN TO PROTECT THE TOPSOIL AS A VALUABLE COMMODITY. TOPSOIL MUST NOT BE STRIPPED DURING UNDESIRABLE WORKING CONDITIONS (E.G. DURING WET WEATHER OR WHEN SOILS ARE SATURATED). TOPSOIL SHALL NOT BE STORED IN SWALES OR IN AREAS WITH POOR DRAINAGE.

SEEDING

1. ALLOWABLE SEED MIXES ARE INCLUDED IN THE CITY OF COLORADO SPRINGS STORMWATER CONSTRUCTION MANUAL. ALTERNATIVE SEED MIXES ARE ACCEPTABLE IF INCLUDED IN AN APPROVED LANDSCAPING PLAN.
2. SEED SHOULD BE DRILL-SEEDED WHENEVER POSSIBLE
 - SEED DEPTH MUST BE $\frac{1}{2}$ TO $\frac{1}{4}$ INCHES WHEN DRILL-SEEDED IS USED
3. BROADCAST SEEDING OR HYDRO-SEEDED WITH TACKIFIER MAY BE SUBSTITUTED ON SLOPES STEEPER THAN 3:1 OR ON OTHER AREAS NOT PRACTICAL TO DRILL SEED.
 - SEEDING RATES MUST BE DOUBLED FOR BROADCAST SEEDING OR INCREASED BY 50% IF USING A BRILLION DRILL OR HYDRO-SEEDED
 - BROADCAST SEEDING MUST BE LIGHTLY HAND-RAKED INTO THE SOIL

MULCHING

1. MULCHING SHOULD BE COMPLETED AS SOON AS PRACTICABLE AFTER SEEDING, HOWEVER PLANTED AREAS MUST BE MULCHED NO LATER THAN 14 DAYS AFTER PLANTING.
2. MULCHING REQUIREMENTS INCLUDE:
 - HAY OR STRAW MULCH
 - ONLY CERTIFIED WEED-FREE AND CERTIFIED SEED-FREE MULCH MAY BE USED. MULCH MUST BE APPLIED AT 2 TONS/ACRE AND ADEQUATELY SECURED BY CRIMPING AND/OR TACKIFIER.
 - CRIMPING MUST NOT BE USED ON SLOPES GREATER THAN 3:1 AND MULCH FIBERS MUST BE TUCKED INTO THE SOIL TO A DEPTH OF 3 TO 4 INCHES.
 - TACKIFIER MUST BE USED IN PLACE OF CRIMPING ON SLOPES STEEPER THAN 3:1.
 - HYDRAULIC MULCHING
 - HYDRAULIC MULCHING IS AN OPTION ON STEEP SLOPES OR WHERE ACCESS IS LIMITED.
 - IF HYDRO-SEEDED IS USED, MULCHING MUST BE APPLIED AS A SEPARATE, SECOND OPERATION.
 - WOOD CELLULOSE FIBERS MIXED WITH WATER MUST BE APPLIED AT A RATE OF 2,000 TO 2,500 POUNDS/ACRE, AND TACKIFIER MUST BE APPLIED AT A RATE OF 100 POUNDS/ACRE.
 - EROSION CONTROL BLANKET
 - EROSION CONTROL BLANKET MAY BE USED IN PLACE OF TRADITIONAL MULCHING METHODS.

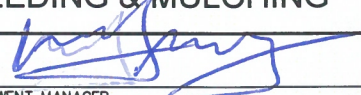

SEEDING & MULCHING		
APPROVED: 		
SWENT MANAGER		
ISSUED: 10/7/19	REVISED: 8/19/2020	DRAWING NO. 900-SM

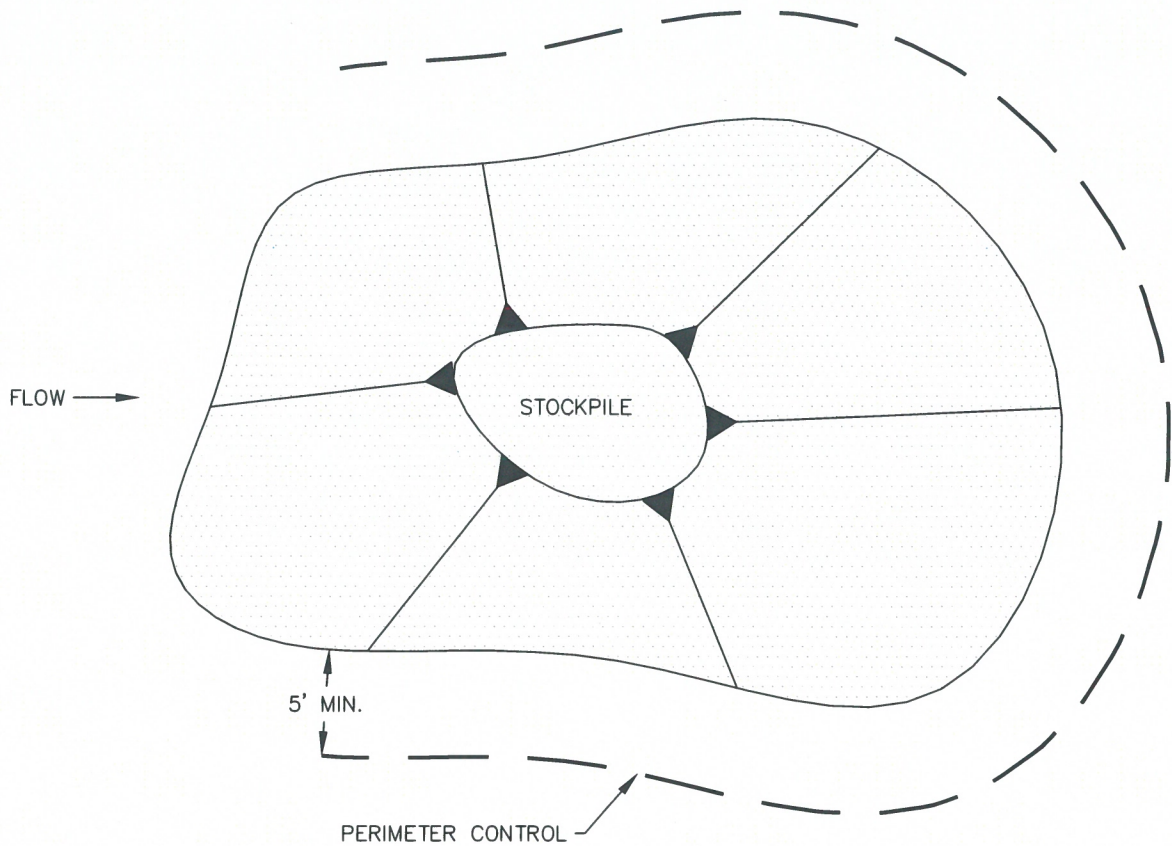

STOCKPILE PROTECTION PLAN

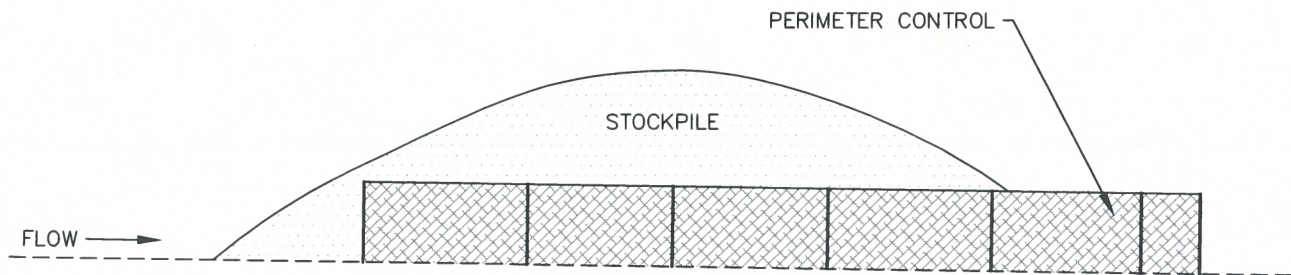

STOCKPILE PROTECTION ELEVATION

INSTALLATION NOTES

1. INSTALL PERIMETER CONTROL AROUND STOCKPILE ON DOWNGRAIDENT SIDE. PERIMETER CONTROL MUST BE SUITABLE TO SITE CONDITIONS AND INSTALLED ACCORDING TO THE RELEVANT DETAIL.
2. FOR STOCKPILES ON THE INTERIOR PORTION OF A CONSTRUCTION SITE, WHERE OTHER DOWNGRAIDENT CONTROLS INCLUDING PERIMETER CONTROL ARE IN PLACE, STOCKPILE PERIMETER CONTROLS MAY NOT BE REQUIRED.

MAINTENANCE NOTES

1. FREQUENT OBSERVATIONS AND MAINTENANCE ARE NECESSARY TO MAINTAIN CONTROL MEASURES IN EFFECTIVE OPERATING CONDITION. INSPECTIONS AND CORRECTIVE MEASURES SHOULD BE DOCUMENTED THOROUGHLY.
2. IF PERIMETER CONTROLS MUST BE MOVED TO ACCESS STOCKPILE, REPLACE PERIMETER CONTROLS BY THE END OF THE WORK DAY.
3. ACCUMULATED SEDIMENT MUST BE REMOVED ACCORDING TO PERIMETER CONTROL DETAIL.

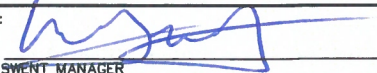

STOCKPILE PROTECTION

APPROVED: 
SWENT MANAGER

ISSUED: 10/7/19	REVISED: 8/19/2020	DRAWING NO. 900-SP
--------------------	-----------------------	-----------------------

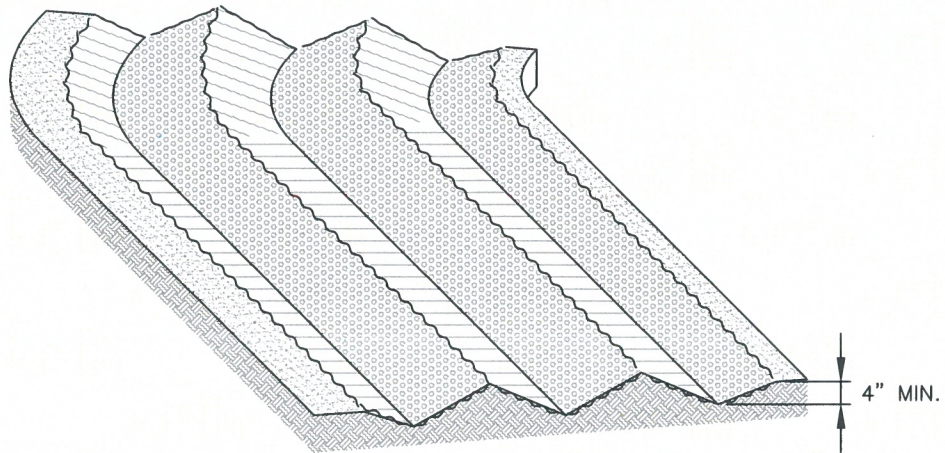

SURFACE ROUGHENING

INSTALLATION NOTES

1. SURFACE ROUGHENING MAY BE USED IN AREAS FLATTER THAN 3:1. INSTALL FURROWS ALONG CONTOUR TO INTERCEPT SHEET FLOW.
2. SURFACE ROUGHENING MAY BE ACCOMPLISHED BY FURROWING, SCARIFYING, RIPPING OR DISKING THE SOIL.
3. FURROWS MUST BE A MINIMUM OF 4" IN DEPTH.
4. SURFACE ROUGHENING SHALL NOT BE USED ON EXTREMELY SANDY OR ROCKY SOILS.

MAINTENANCE NOTES

1. FREQUENT OBSERVATIONS AND MAINTENANCE ARE NECESSARY TO MAINTAIN CONTROL MEASURES IN EFFECTIVE OPERATING CONDITION. INSPECTIONS AND CORRECTIVE MEASURES SHOULD BE DOCUMENTED THOROUGHLY.
2. VEHICLES AND EQUIPMENT SHALL NOT BE DRIVEN OVER AREAS THAT HAVE BEEN SURFACE ROUGHENED.

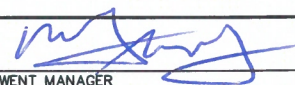

 <p>STORMWATER ENTERPRISE</p>	SURFACE ROUGHENING		
	APPROVED:  SWENT MANAGER		
	ISSUED: 10/7/19	REVISED: 8/19/2020	DRAWING NO. 900-SR

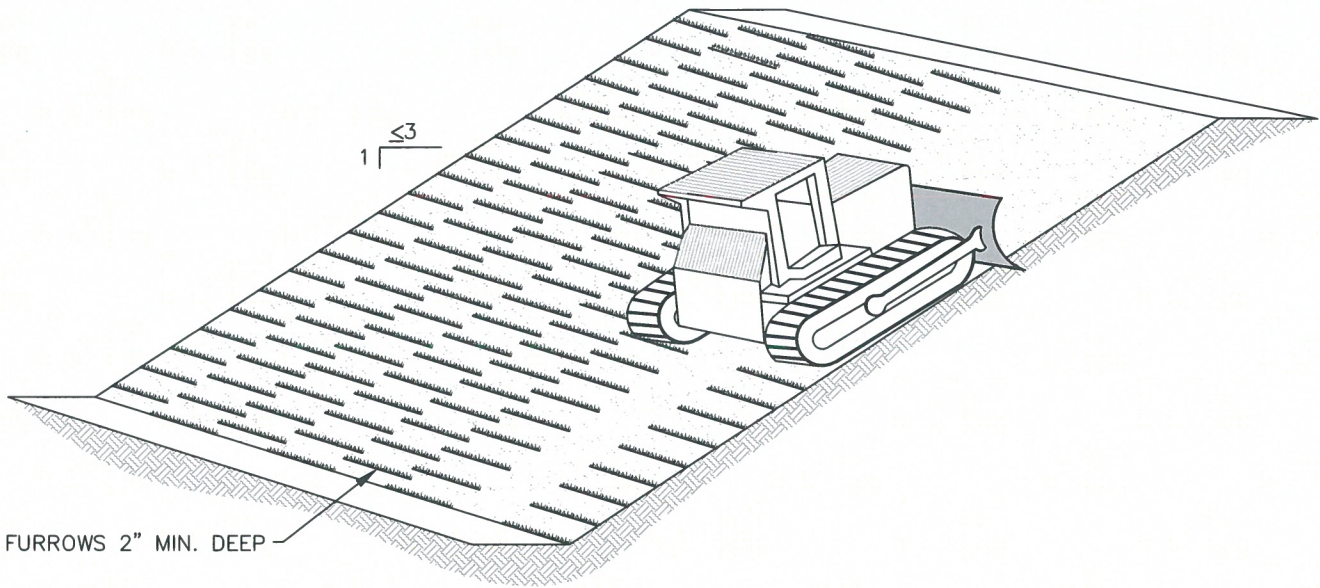

SLOPE TRACKING



INSTALLATION NOTES

1. SLOPE TRACKING MAY BE USED ON SLOPES 3:1 OR STEEPER.
2. TRACKING GROOVES SHALL BE PERPENDICULAR TO THE SLOPE.
3. SLOPE TRACKING SHALL NOT BE USED ON EXTREMELY SANDY OR ROCKY SOILS.

MAINTENANCE NOTES

1. FREQUENT OBSERVATIONS AND MAINTENANCE ARE NECESSARY TO MAINTAIN CONTROL MEASURES IN EFFECTIVE OPERATING CONDITION. INSPECTIONS AND CORRECTIVE MEASURES SHOULD BE DOCUMENTED THOROUGHLY.
2. VEHICLES AND EQUIPMENT SHALL NOT BE DRIVEN OVER AREAS THAT HAVE BEEN SLOPE TRACKED.



 <p>STORMWATER ENTERPRISE</p>	SLOPE TRACKING	
	APPROVED:  SWENT MANAGER	
	ISSUED: 10/7/19	REVISED: 8/19/2020

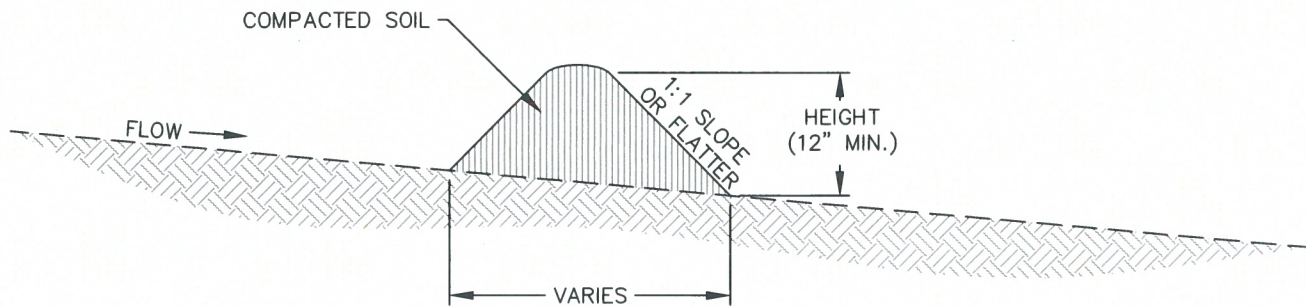

TEMPORARY COMPACTED BERM

INSTALLATION NOTES

1. COMPACTED BERM MUST BE A MINIMUM HEIGHT OF ONE FOOT. BASE WIDTH IS DETERMINED BY HEIGHT.
2. COMPACTED BERMS MUST BE ADEQUATELY COMPACTED. NOT ALL SOILS ARE SUITABLE FOR COMPACTED BERMS.
3. INSTALL COMPACTED BERMS ALONG CONTOUR; DO NOT INSTALL PERPENDICULAR TO SLOPE.
4. THE MAXIMUM TRIBUTARY DRAINAGE AREA PER 100 LINEAR FEET OF COMPACTED BERMS SHALL BE $\frac{1}{4}$ ACRE.

MAINTENANCE NOTES

1. FREQUENT OBSERVATIONS AND MAINTENANCE ARE NECESSARY TO MAINTAIN CONTROL MEASURES IN EFFECTIVE OPERATING CONDITION. INSPECTIONS AND CORRECTIVE MEASURES SHOULD BE DOCUMENTED THOROUGHLY.
2. ACCUMULATED SEDIMENT MUST BE REMOVED WHEN THE HEIGHT REACHES $\frac{1}{2}$ OF THE DESIGN DEPTH OF THE BERM.



TEMPORARY COMPACTED BERM

APPROVED:		
SWENT MANAGER		
ISSUED: 10/7/19	REVISED: 8/19/2020	DRAWING NO. 900-TCB

INLETS TO SEDIMENT BASIN SHALL ENTER AT FURTHEST DISTANCE TO OUTLET AND SHALL CONSIST OF A TEMPORARY SLOPE DRAIN

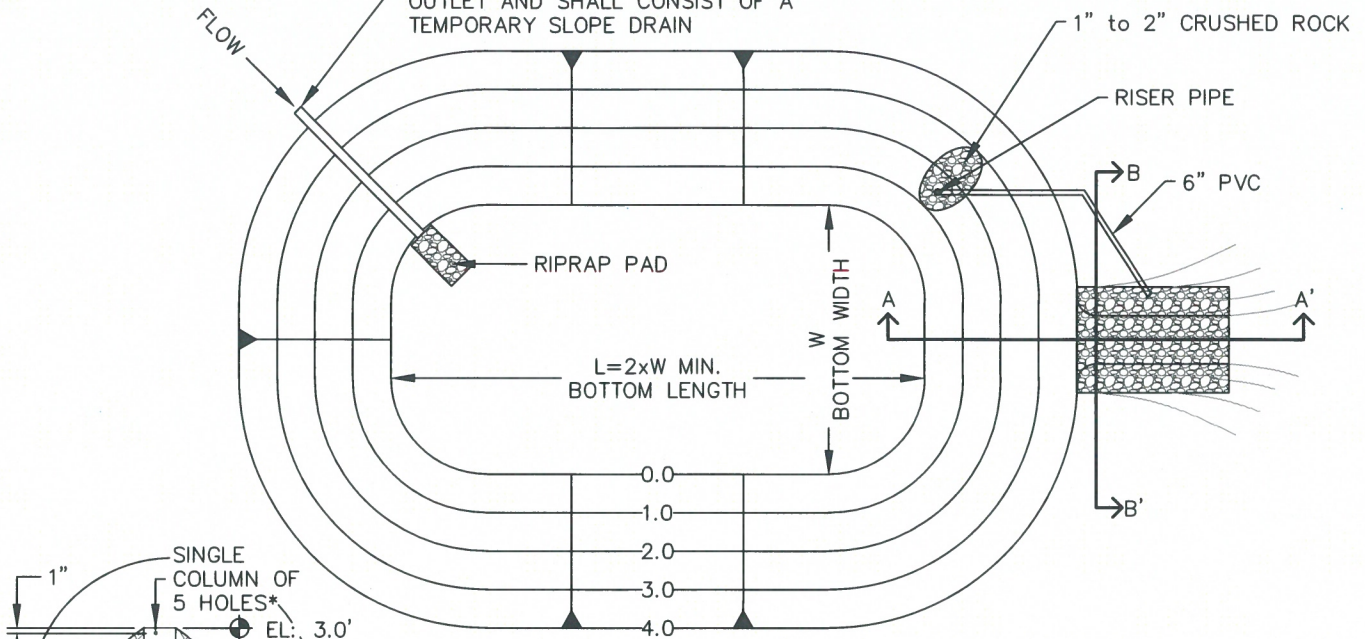

SEDIMENT BASIN PLAN

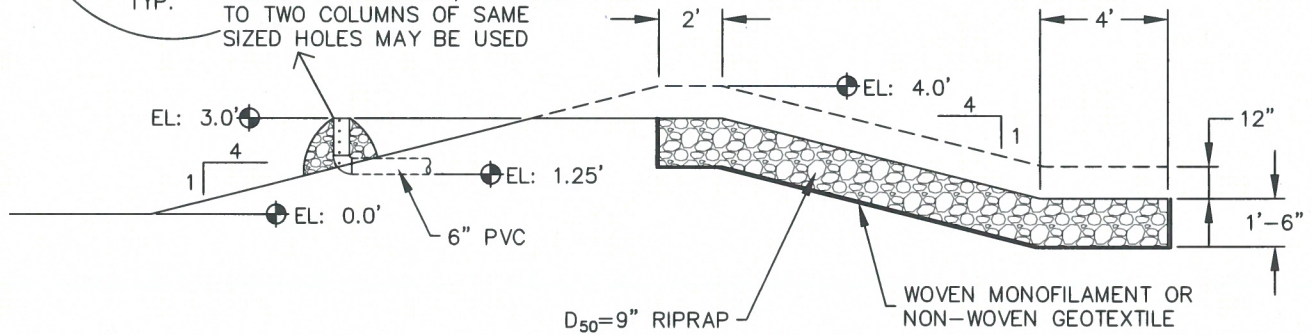
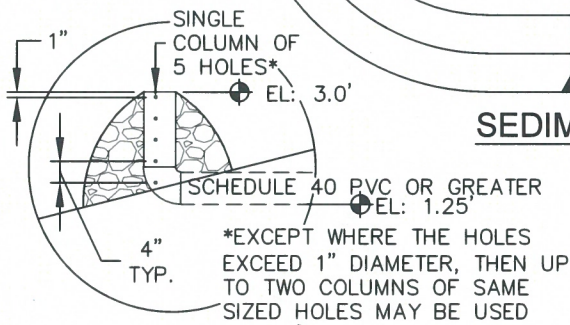

SECTION A-A'

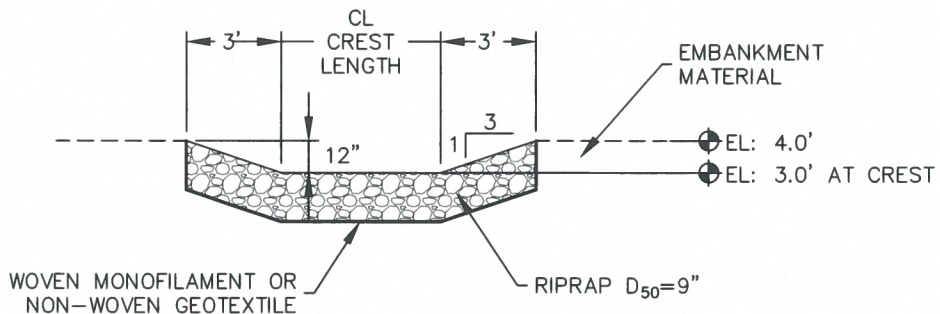

SECTION B-B'



TEMPORARY SEDIMENT BASIN

APPROVED: SWENT MANAGER

ISSUED: 10/7/19	REVISED: 8/19/2020	DRAWING NO. 900-TSB-1
--------------------	-----------------------	--------------------------

TABLE SB-1, SIZING INFORMATION FOR
STANDARD SEDIMENT BASIN

UPSTREAM DRAINAGE AREA (ROUNDED TO NEAREST ACRE), (AC)	BASIN BOTTOM WIDTH (W), (FT)	SPILLWAY CREST LENGTH (CL), (FT)	HOLE DIAMETER (HD), (IN)
1	12½"	2	9/32
2	21	3	13/16
3	28	5	½
4	33½	6	9/16
5	38½	8	2½/32
6	43	9	2½/32
7	47¼	11	25/32
8	51	12	27/32
9	55	13	7/8
10	58¼	15	15/16
11	61	16	3½/32
12	64	18	1
13	67½	19	1¼/6
14	70½	21	1½/8
15	73¼	22	1¾/6

INSTALLATION NOTES

- FOR STANDARD BASIN, BOTTOM DIMENSION MAY BE MODIFIED AS LONG AS BOTTOM AREA IS NOT REDUCED.
- EMBANKMENT MATERIAL SHALL CONSIST OF SOIL FREE OF DEBRIS, ORGANIC MATERIAL, AND ROCKS OR CONCRETE GREATER THAN 3 INCHES, AND SHALL HAVE A MINIMUM OF 15 PERCENT BY WEIGHT PASSING THE No. 200 SIEVE
- EMBANKMENT MATERIAL SHALL BE COMPACTED TO AT LEAST 95 PERCENT OF MAXIMUM DENSITY IN ACCORDANCE WITH ASTM D-698.
- PIPE SCHEDULE 40 OR GREATER SHALL BE USED.
- THE DETAILS SHOWN ON THESE SHEETS PERTAIN TO STANDARD SEDIMENT BASIN(S) FOR DRAINAGE AREAS LESS THAN 15 ACRES. SEE CONSTRUCTION DRAWINGS FOR EMBANKMENT, STORAGE VOLUME, SPILLWAY, OUTLET, AND OUTLET PROTECTION DETAILS FOR ANY SEDIMENT BASIN(S) THAT HAVE BEEN INDIVIDUALLY DESIGNED FOR DRAINAGE AREAS LARGER THAN 15 ACRES. DESIGN CALCULATIONS MUST BE APPROVED PRIOR TO IMPLEMENTATION.

MAINTENANCE NOTES

- FREQUENT OBSERVATIONS AND MAINTENANCE ARE NECESSARY TO MAINTAIN CONTROL MEASURES IN EFFECTIVE OPERATING CONDITION. INSPECTIONS AND CORRECTIVE MEASURES SHOULD BE DOCUMENTED THOROUGHLY.
- SEDIMENT ACCUMULATED IN BASIN SHALL BE REMOVED AS NEEDED TO MAINTAIN CONTROL MEASURE EFFECTIVENESS, TYPICALLY WHEN SEDIMENT DEPTH REACHES ONE FOOT (I.E. TWO FEET BELOW SPILLWAY CREST).
- SEDIMENT BASINS ARE TO REMAIN IN PLACE UNTIL THE UPSTREAM DISTURBED AREA IS PERMANENTLY STABILIZED.
- PERMANENTLY STABILIZE AREA AFTER SEDIMENT BASIN REMOVAL.



TEMPORARY SEDIMENT BASIN		
APPROVED: 		
SWENT MANAGER		
ISSUED: 10/7/19	REVISED: 8/19/2020	DRAWING NO. 900-TSB-2

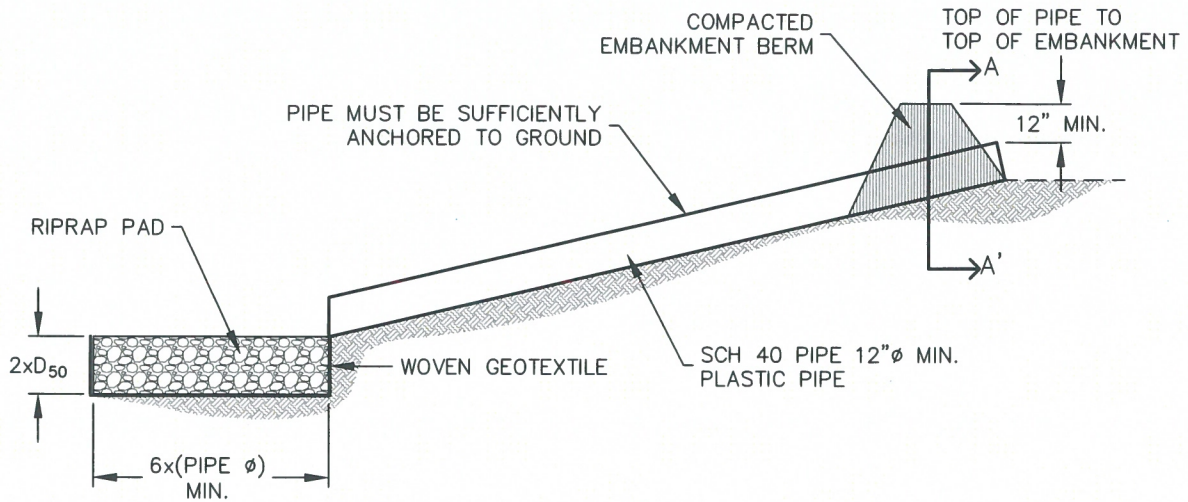

TEMPORARY SLOPE DRAIN

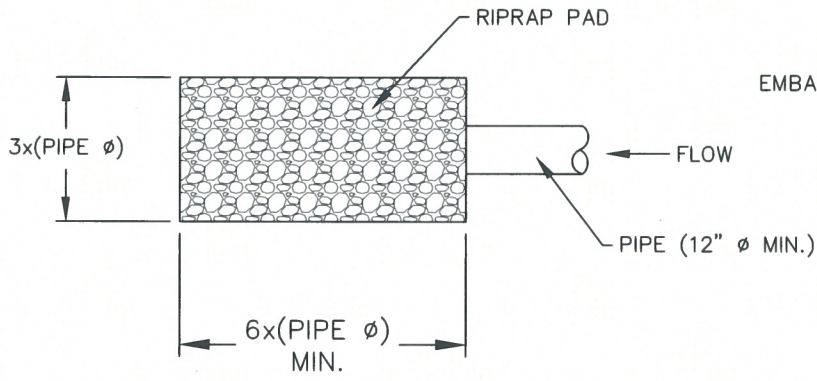

RIPRAP PAD PLAN

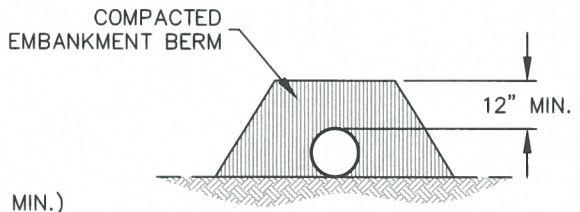

SECTION A-A'

INSTALLATION NOTES

1. THE LISTED DIMENSIONS ARE CONSIDERED A MINIMUM; LARGER DRAINS CAN BE IMPLEMENTED BY THE CONTRACTOR.
2. DETAILS SHOW MINIMUM COVER; INCREASE COVER AS NECESSARY.

MAINTENANCE NOTES

1. FREQUENT OBSERVATIONS AND MAINTENANCE ARE NECESSARY TO MAINTAIN CONTROL MEASURES IN EFFECTIVE OPERATING CONDITION. INSPECTIONS AND CORRECTIVE MEASURES SHOULD BE DOCUMENTED THOROUGHLY.
2. INSPECT INLETS AND OUTLETS AFTER STORMS TO PREVENT EXCESS CLOGGING. BREACHES IN PIPES SHOULD BE REPAIRED AS SOON AS FEASIBLY POSSIBLE.
3. INSPECT RIPRAP PAD AT OUTLET FOR SIGNS OF EROSION. IF SIGNS OF EROSION EXIST, ADDITIONAL ARMORING MAY BE INSTALLED.
4. TEMPORARY SLOPE DRAINS SHOULD REMAIN UNTIL THEY ARE NOT NEEDED, BUT SHOULD BE REMOVED BEFORE THE END OF CONSTRUCTION.
5. PERMANENTLY STABILIZE AREA AFTER TEMPORARY SLOPE DRAINS ARE REMOVED.



	TEMPORARY SLOPE DRAIN	
	APPROVED:	
ISSUED:	REVISED:	DRAWING NO.
10/7/19	8/19/2020	900-TSD

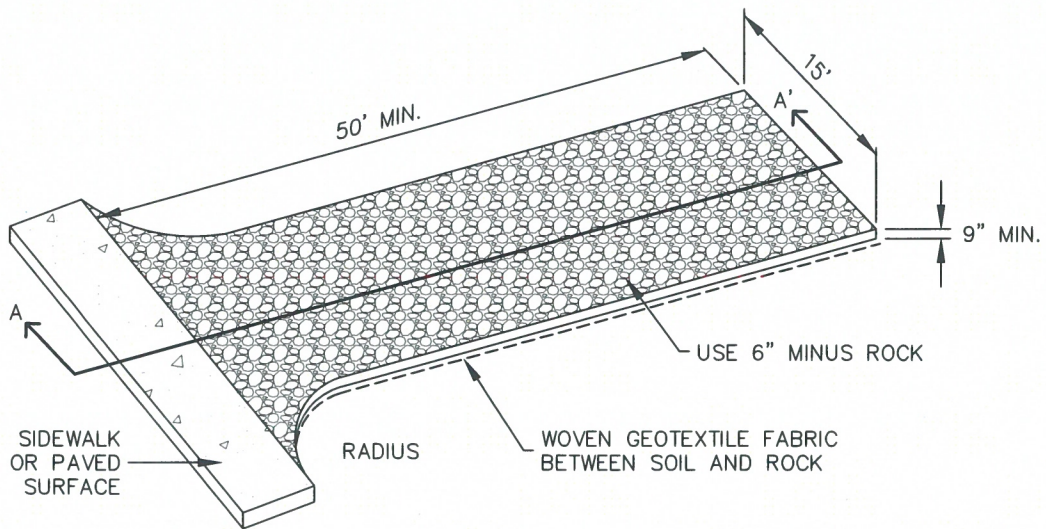

AGGREGATE VEHICLE TRACKING CONTROL

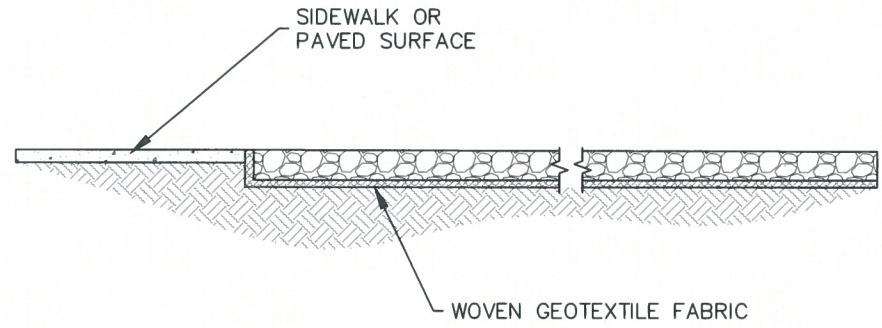

SECTION A-A'

INSTALLATION NOTES

1. A STABILIZED CONSTRUCTION ENTRANCE/EXIT SHOULD BE LOCATED AT ALL POINTS WHERE VEHICLES EXIT THE CONSTRUCTION SITE TO ADJACENT ROADWAY.
2. STABILIZED CONSTRUCTION ENTRANCE/EXITS SHALL BE INSTALLED PRIOR TO ANY LAND DISTURBING ACTIVITIES.
3. RADIUS MUST BE ADEQUATE FOR INTENDED CONSTRUCTION VEHICLE TURNING.
4. ROCK SHOULD CONSIST OF 6" MINUS ROCK.
5. INSTALL CONSTRUCTION FENCE ON BOTH SIDES OF VEHICLE TRACKING CONTROL PAD WHEN NEEDED OR REQUIRED BY INSPECTOR.

MAINTENANCE NOTES

1. FREQUENT OBSERVATIONS AND MAINTENANCE ARE NECESSARY TO MAINTAIN CONTROL MEASURES IN EFFECTIVE OPERATING CONDITION. INSPECTIONS AND CORRECTIVE MEASURES SHOULD BE DOCUMENTED THOROUGHLY.
2. SEDIMENT TRACKED ONTO THE ADJACENT ROAD SHALL BE REMOVED DAILY, BY SWEEPING OR SHOVELING, AND NEVER WASHED DOWN STORM DRAINS.
3. ROUGHEN, REPLACE AND/OR ADD ROCK AS NEEDED TO MAINTAIN CONSISTENT DEPTH AND TO PREVENT SEDIMENT TRACKING ONTO ADJACENT STREET.
4. PERMANENTLY STABILIZE AREA AFTER VEHICLE TRACKING CONTROL IS REMOVED.



VEHICLE TRACKING CONTROL		
APPROVED: 		
SWENT MANAGER		
ISSUED: 10/7/19	REVISED: 8/19/2020	DRAWING NO. 900-VTC

Description

Earth dikes and drainage swales are temporary storm conveyance channels constructed either to divert runoff around slopes or to convey runoff to additional sediment control BMPs prior to discharge of runoff from a site. Drainage swales may be lined or unlined, but if an unlined swale is used, it must be well compacted and capable of resisting erosive velocities.

Appropriate Uses

Earth dikes and drainage swales are typically used to control the flow path of runoff at a construction site by diverting runoff around areas prone to erosion, such as steep slopes. Earth dikes and drainage swales may also be constructed as temporary conveyance features. This will direct runoff to additional sediment control treatment BMPs, such as sediment traps or basins.



Photograph ED/DS-1. Example of an earth dike used to divert flows at a construction site. Photo courtesy of CDOT.

Design and Installation

When earth dikes are used to divert water for slope protection, the earth dike typically consists of a horizontal ridge of soil placed perpendicular to the slope and angled slightly to provide drainage along the contour. The dike is used in conjunction with a swale or a small channel upslope of the berm to convey the diverted water. Temporary diversion dikes can be constructed by excavation of a V-shaped trench or ditch and placement of the fill on the downslope side of the cut. There are two types of placement for temporary slope diversion dikes:

- A dike located at the top of a slope to divert upland runoff away from the disturbed area and convey it in a temporary or permanent channel.
- A diversion dike located at the base or mid-slope of a disturbed area to intercept runoff and reduce the effective slope length.

Depending on the project, either an earth dike or drainage swale may be more appropriate. If there is a need for cut on the project, then an excavated drainage swale may be better suited. When the project is primarily fill, then a conveyance constructed using a berm may be the better option.

All dikes or swales receiving runoff from a disturbed area should direct stormwater to a sediment control BMP such as a sediment trap or basin.

Earth Dikes and Drainage Swales	
Functions	
Erosion Control	Yes
Sediment Control	Moderate
Site/Material Management	No

EC-10 Earth Dikes and Drainage Swales (ED/DS)

Unlined dikes or swales should only be used for intercepting sheet flow runoff and are not intended for diversion of concentrated flows.

Details with notes are provided for several design variations, including:

ED-1. Unlined Earth Dike formed by Berm

DS-1. Unlined Excavated Swale

DS-2. Unlined Swale Formed by Cut and Fill

DS-3. ECB-lined Swale

DS-4. Synthetic-lined Swale

DS-5. Riprap-lined Swale

The details also include guidance on permissible velocities for cohesive channels if unlined approaches will be used.

Maintenance and Removal

Inspect earth dikes for stability, compaction, and signs of erosion and repair. Inspect side slopes for erosion and damage to erosion control fabric. Stabilize slopes and repair fabric as necessary. If there is reoccurring extensive damage, consider installing rock check dams or lining the channel with riprap.

If drainage swales are not permanent, remove dikes and fill channels when the upstream area is stabilized. Stabilize the fill or disturbed area immediately following removal by revegetation or other permanent stabilization method approved by the local jurisdiction.

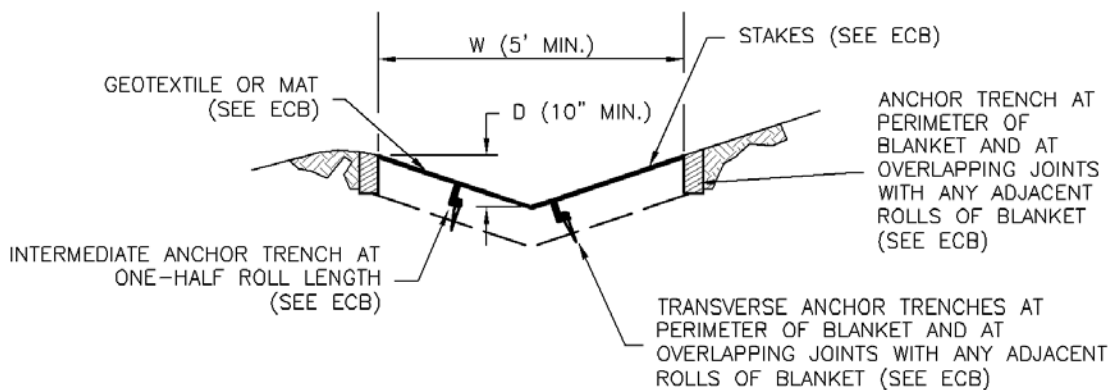
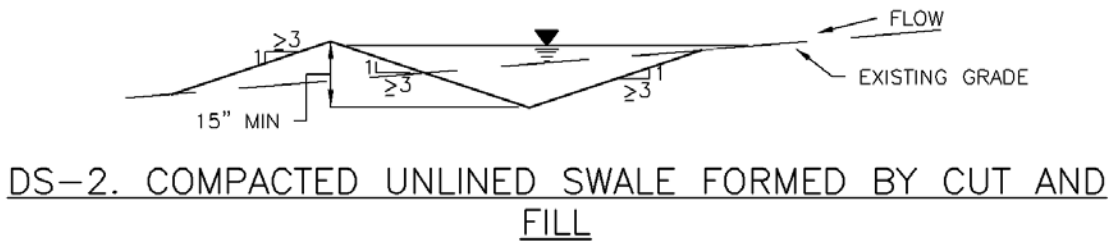
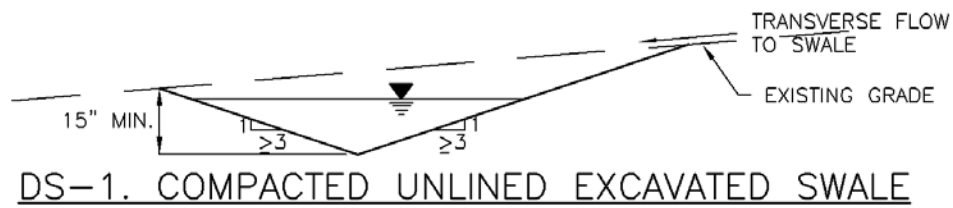
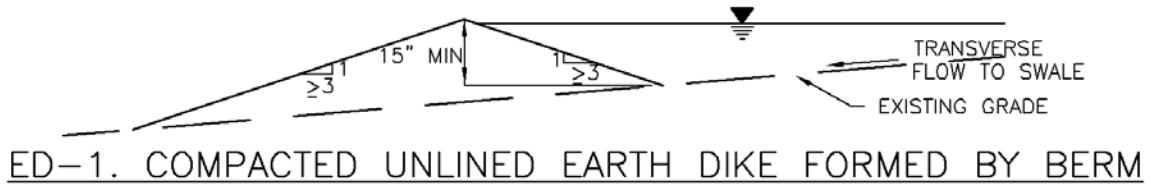
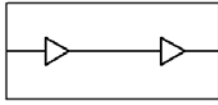

EC-10 Earth Dikes and Drainage Swales (ED/DS)

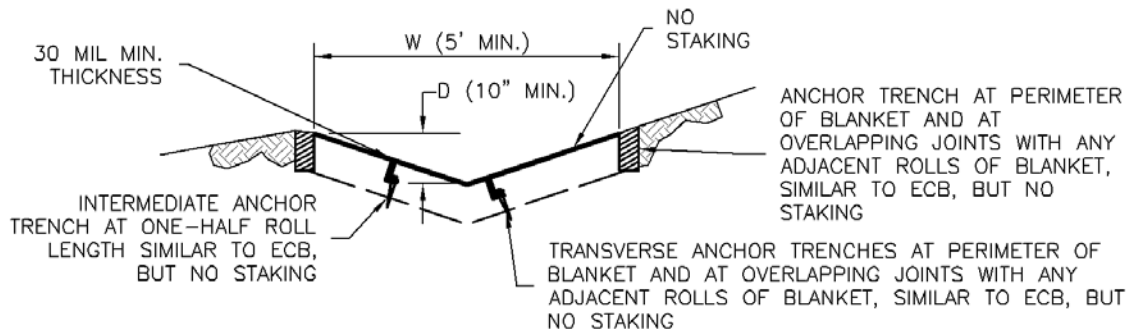

DS-4. SYNTHETIC LINED SWALE

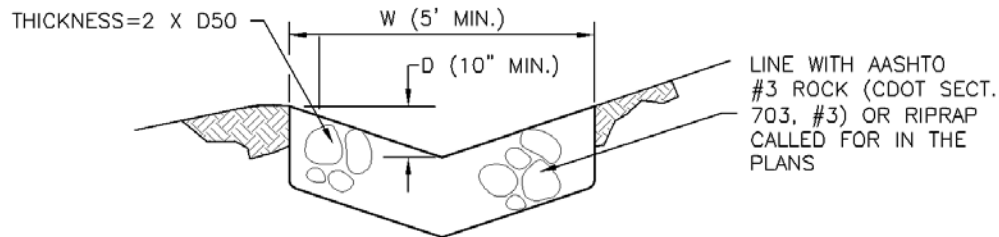

DS-5. RIPRAP LINED SWALE

EARTH DIKE AND DRAINAGE SWALE INSTALLATION NOTES

1. SEE SITE PLAN FOR:
 - LOCATION OF DIVERSION SWALE
 - TYPE OF SWALE (UNLINED, COMPACTED AND/OR LINED).
 - LENGTH OF EACH SWALE.
 - DEPTH, D, AND WIDTH, W DIMENSIONS.
 - FOR ECB/TRM LINED DITCH, SEE ECB DETAIL.
 - FOR RIPRAP LINED DITCH, SIZE OF RIPRAP, D50.
2. SEE DRAINAGE PLANS FOR DETAILS OF PERMANENT CONVEYANCE FACILITIES AND/OR DIVERSION SWALES EXCEEDING 2-YEAR FLOW RATE OR 10 CFS.
3. EARTH DIKES AND SWALES INDICATED ON SWMP PLAN SHALL BE INSTALLED PRIOR TO LAND-DISTURBING ACTIVITIES IN PROXIMITY.
4. EMBANKMENT IS TO BE COMPACTED TO 90% OF MAXIMUM DENSITY AND WITHIN 2% OF OPTIMUM MOISTURE CONTENT ACCORDING TO ASTM D698.
5. SWALES ARE TO DRAIN TO A SEDIMENT CONTROL BMP.
6. FOR LINED DITCHES, INSTALLATION OF ECB/TRM SHALL CONFORM TO THE REQUIREMENTS OF THE ECB DETAIL.
7. WHEN CONSTRUCTION TRAFFIC MUST CROSS A DIVERSION SWALE, INSTALL A TEMPORARY CULVERT WITH A MINIMUM DIAMETER OF 12 INCHES.

EARTH DIKE AND DRAINAGE SWALE MAINTENANCE NOTES

1. INSPECT BMPs EACH WORKDAY, AND MAINTAIN THEM IN EFFECTIVE OPERATING CONDITION. MAINTENANCE OF BMPs SHOULD BE PROACTIVE, NOT REACTIVE. INSPECT BMPs AS SOON AS POSSIBLE (AND ALWAYS WITHIN 24 HOURS) FOLLOWING A STORM THAT CAUSES SURFACE EROSION, AND PERFORM NECESSARY MAINTENANCE.
2. FREQUENT OBSERVATIONS AND MAINTENANCE ARE NECESSARY TO MAINTAIN BMPs IN EFFECTIVE OPERATING CONDITION. INSPECTIONS AND CORRECTIVE MEASURES SHOULD BE DOCUMENTED THOROUGHLY.
3. WHERE BMPs HAVE FAILED, REPAIR OR REPLACEMENT SHOULD BE INITIATED UPON DISCOVERY OF THE FAILURE.
4. SWALES SHALL REMAIN IN PLACE UNTIL THE END OF CONSTRUCTION; IF APPROVED BY LOCAL JURISDICTION, SWALES MAY BE LEFT IN PLACE.
5. WHEN A SWALE IS REMOVED, THE DISTURBED AREA SHALL BE COVERED WITH TOPSOIL, SEEDED AND MULCHED OR OTHERWISE STABILIZED IN A MANNER APPROVED BY LOCAL JURISDICTION.

(DETAIL ADAPTED FROM DOUGLAS COUNTY, COLORADO AND THE CITY OF COLORADO SPRINGS, COLORADO, NOT AVAILABLE IN AUTOCAD)

NOTE: MANY JURISDICTIONS HAVE BMP DETAILS THAT VARY FROM UDFCD STANDARD DETAILS. CONSULT WITH LOCAL JURISDICTIONS AS TO WHICH DETAIL SHOULD BE USED WHEN DIFFERENCES ARE NOTED.

Description

A stabilized staging area is a clearly designated area where construction equipment and vehicles, stockpiles, waste bins, and other construction-related materials are stored. The contractor office trailer may also be located in this area. Depending on the size of the construction site, more than one staging area may be necessary.



Photograph SSA-1. Example of a staging area with a gravel surface to prevent mud tracking and reduce runoff. Photo courtesy of Douglas County.

Appropriate Uses

Most construction sites will require a staging area, which should be clearly designated in SWMP drawings. The layout of the staging area may vary depending on the type of construction activity. Staging areas located in roadways due to space constraints require special measures to avoid materials being washed into storm inlets.

Design and Installation

Stabilized staging areas should be completed prior to other construction activities beginning on the site. Major components of a stabilized staging area include:

- Appropriate space to contain storage and provide for loading/unloading operations, as well as parking if necessary.
- A stabilized surface, either paved or covered, with 3-inch diameter aggregate or larger.
- Perimeter controls such as silt fence, sediment control logs, or other measures.
- Construction fencing to prevent unauthorized access to construction materials.
- Provisions for Good Housekeeping practices related to materials storage and disposal, as described in the Good Housekeeping BMP Fact Sheet.
- A stabilized construction entrance/exit, as described in the Vehicle Tracking Control BMP Fact Sheet, to accommodate traffic associated with material delivery and waste disposal vehicles.

Over-sizing the stabilized staging area may result in disturbance of existing vegetation in excess of that required for the project. This increases costs, as well as requirements for long-term stabilization following the construction period. When designing the stabilized staging area, minimize the area of disturbance to the extent practical.

Stabilized Staging Area	
Functions	
Erosion Control	Yes
Sediment Control	Moderate
Site/Material	Yes

Minimizing Long-Term Stabilization Requirements

- Utilize off-site parking and restrict vehicle access to the site.
- Use construction mats in lieu of rock when staging is provided in an area that will not be disturbed otherwise.
- Consider use of a bermed contained area for materials and equipment that do not require a stabilized surface.
- Consider phasing of staging areas to avoid disturbance in an area that will not be otherwise disturbed.

See Detail SSA-1 for a typical stabilized staging area and SSA-2 for a stabilized staging area when materials staging in roadways is required.

Maintenance and Removal

Maintenance of stabilized staging areas includes maintaining a stable surface cover of gravel, repairing perimeter controls, and following good housekeeping practices.

When construction is complete, debris, unused stockpiles and materials should be recycled or properly disposed. In some cases, this will require disposal of contaminated soil from equipment leaks in an appropriate landfill. Staging areas should then be permanently stabilized with vegetation or other surface cover planned for the development.

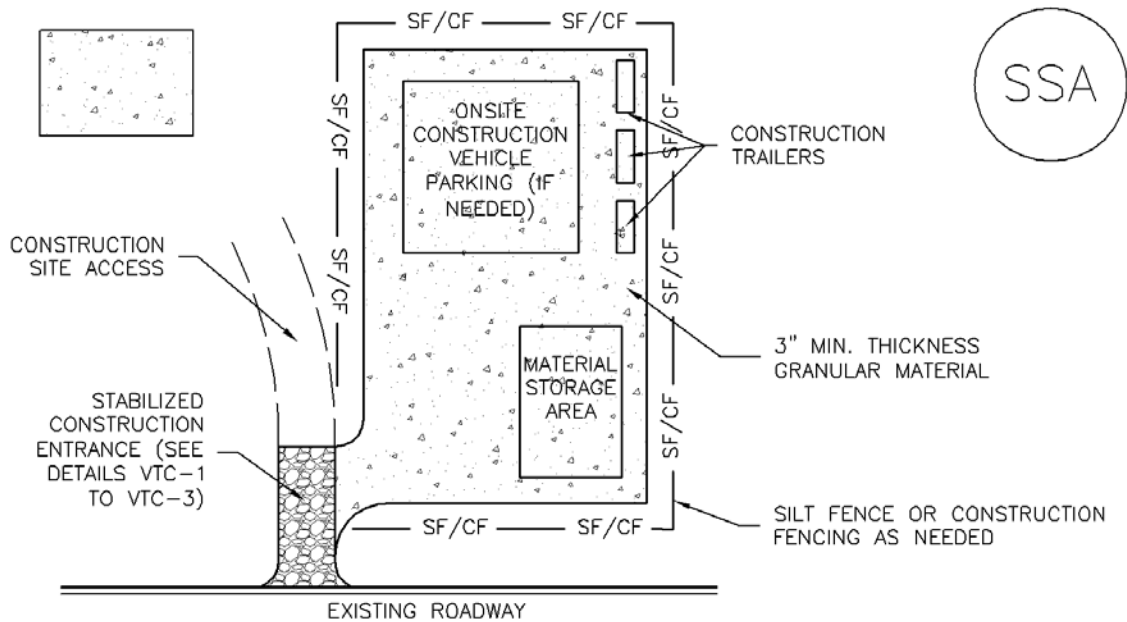

SSA-1. STABILIZED STAGING AREA

STABILIZED STAGING AREA INSTALLATION NOTES

1. SEE PLAN VIEW FOR
-LOCATION OF STAGING AREA(S).
-CONTRACTOR MAY ADJUST LOCATION AND SIZE OF STAGING AREA WITH APPROVAL FROM THE LOCAL JURISDICTION.
2. STABILIZED STAGING AREA SHOULD BE APPROPRIATE FOR THE NEEDS OF THE SITE. OVERSIZING RESULTS IN A LARGER AREA TO STABILIZE FOLLOWING CONSTRUCTION.
3. STAGING AREA SHALL BE STABILIZED PRIOR TO OTHER OPERATIONS ON THE SITE.
4. THE STABILIZED STAGING AREA SHALL CONSIST OF A MINIMUM 3" THICK GRANULAR MATERIAL.
5. UNLESS OTHERWISE SPECIFIED BY LOCAL JURISDICTION, ROCK SHALL CONSIST OF DOT SECT. #703, AASHTO #3 COARSE AGGREGATE OR 6" (MINUS) ROCK.
6. ADDITIONAL PERIMETER BMPs MAY BE REQUIRED INCLUDING BUT NOT LIMITED TO SILT FENCE AND CONSTRUCTION FENCING.

STABILIZED STAGING AREA MAINTENANCE NOTES

1. INSPECT BMPs EACH WORKDAY, AND MAINTAIN THEM IN EFFECTIVE OPERATING CONDITION. MAINTENANCE OF BMPs SHOULD BE PROACTIVE, NOT REACTIVE. INSPECT BMPs AS SOON AS POSSIBLE (AND ALWAYS WITHIN 24 HOURS) FOLLOWING A STORM THAT CAUSES SURFACE EROSION, AND PERFORM NECESSARY MAINTENANCE.
2. FREQUENT OBSERVATIONS AND MAINTENANCE ARE NECESSARY TO MAINTAIN BMPs IN EFFECTIVE OPERATING CONDITION. INSPECTIONS AND CORRECTIVE MEASURES SHOULD BE DOCUMENTED THOROUGHLY.
3. WHERE BMPs HAVE FAILED, REPAIR OR REPLACEMENT SHOULD BE INITIATED UPON DISCOVERY OF THE FAILURE.
4. ROCK SHALL BE REAPPLIED OR REGRADED AS NECESSARY IF RUTTING OCCURS OR UNDERLYING SUBGRADE BECOMES EXPOSED.

STABILIZED STAGING AREA MAINTENANCE NOTES

5. STABILIZED STAGING AREA SHALL BE ENLARGED IF NECESSARY TO CONTAIN PARKING, STORAGE, AND UNLOADING/LOADING OPERATIONS.

6. THE STABILIZED STAGING AREA SHALL BE REMOVED AT THE END OF CONSTRUCTION. THE GRANULAR MATERIAL SHALL BE REMOVED OR, IF APPROVED BY THE LOCAL JURISDICTION, USED ON SITE, AND THE AREA COVERED WITH TOPSOIL, SEEDED AND MULCHED OR OTHERWISE STABILIZED IN A MANNER APPROVED BY LOCAL JURISDICTION.

NOTE: MANY MUNICIPALITIES PROHIBIT THE USE OF RECYCLED CONCRETE AS GRANULAR MATERIAL FOR STABILIZED STAGING AREAS DUE TO DIFFICULTIES WITH RE-ESTABLISHMENT OF VEGETATION IN AREAS WHERE RECYCLED CONCRETE WAS PLACED.

NOTE: MANY JURISDICTIONS HAVE BMP DETAILS THAT VARY FROM UDFCD STANDARD DETAILS. CONSULT WITH LOCAL JURISDICTIONS AS TO WHICH DETAIL SHOULD BE USED WHEN DIFFERENCES ARE NOTED.

(DETAILS ADAPTED FROM DOUGLAS COUNTY, COLORADO, NOT AVAILABLE IN AUTOCAD)

Description

Street sweeping and vacuuming remove sediment that has been tracked onto roadways to reduce sediment transport into storm drain systems or a surface waterway.

Appropriate Uses

Use this practice at construction sites where vehicles may track sediment offsite onto paved roadways.

Design and Installation

Street sweeping or vacuuming should be conducted when there is noticeable sediment accumulation on roadways adjacent to the construction site. Typically, this will be concentrated at the entrance/exit to the construction site. Well-maintained stabilized construction entrances, vehicle tracking controls and tire wash facilities can help reduce the necessary frequency of street sweeping and vacuuming.

On smaller construction sites, street sweeping can be conducted manually using a shovel and broom. Never wash accumulated sediment on roadways into storm drains.

Maintenance and Removal

- Inspect paved roads around the perimeter of the construction site on a daily basis and more frequently, as needed. Remove accumulated sediment, as needed.
- Following street sweeping, check inlet protection that may have been displaced during street sweeping.
- Inspect area to be swept for materials that may be hazardous prior to beginning sweeping operations.



Photograph SS-1. A street sweeper removes sediment and potential pollutants along the curb line at a construction site. Photo courtesy of Tom Gore.

Street Sweeping/ Vacuuming	
Functions	
Erosion Control	No
Sediment Control	Yes
Site/Material Management	Yes

Description

Good housekeeping practices are designed to maintain a clean and orderly work environment. The most effective first steps towards preventing pollution in stormwater from work sites simply involve using common sense to improve the facility's basic housekeeping methods. Poor housekeeping practices result in increased waste and potential for stormwater contamination.

A clean and orderly work site reduces the possibility of accidental spills caused by mishandling of chemicals and equipment and should reduce safety hazards to personnel. A well-maintained material and chemical storage area will reduce the possibility of stormwater mixing with pollutants.



Photograph GH-1. Use dry clean-up methods to remove spilled materials. Photo courtesy of Colorado Nonpoint Source Program.

Some simple procedures a facility can use to promote good housekeeping include improved operation and maintenance of machinery and processes, material storage practices, material inventory controls, routine and regular clean-up schedules, maintaining well organized work areas, signage, and educational programs for employees and the general public about all of these practices.

Appropriate Uses

Good housekeeping practices require education and training, typically targeted to industries and businesses, municipal employees, as well as the general public.

Practice Guidelines

Good housekeeping practices include these general areas:

- Operation and Maintenance
- Material Storage
- Material Inventory
- Training and Participation.

Operation and Maintenance

Consider implementing the following practices:

- Maintain dry and clean floors and ground surfaces by using brooms, shovels, vacuums or cleaning machines, rather than wet clean-up methods.
- Regularly collect and dispose of garbage and waste material.

- Routinely inspect equipment to ensure that it is functioning properly without leaking and conduct preventative maintenance and needed repairs.
- Train employees on proper clean up and spill response procedures.
- Designate separate areas of the site for auto parking, vehicle refueling and routine maintenance.
- Promptly clean up leaks, drips and other spills.
- Cover and maintain dumpsters and waste receptacles. Add additional dumpsters or increase frequency of waste collection if overflowing conditions reoccur.
- Where outdoor painting and sanding occur, implement these practices:
 - Conduct these activities in designated areas that provide adequate protection to prevent overspray and uncontrolled emissions. All operations should be conducted on paved surfaces to facilitate cleanup.
 - Use portable containment as necessary for outside operations.
 - Clean up and properly dispose of excess paint, paint chips, protective coatings, grit waste, etc.
- Maintain vegetation on facility grounds in a manner that minimizes erosion. Follow the Landscape Maintenance and Pesticide, Herbicide and Fertilizer Usage BMPs to ensure that minimum amounts of chemicals needed for healthy vegetation are applied in a manner that minimizes transport of these materials in runoff.

Material Storage Practices

Proper storage techniques include the following:

- Provide adequate aisle space to facilitate material transfer and ease of access for inspection.
- Store containers, drums, and bags away from direct traffic routes to reduce container damage resulting in accidental spills.
- Stack containers according to manufacturer's instructions to avoid damaging the containers from improper weight distribution. Also store materials in accordance with directions in Material Safety Data Sheets (MSDSs).
- Store containers on pallets or similar devices to prevent corrosion of containers that results from containers coming in contact with moisture on the ground.
- Store toxic or hazardous liquids within curbed areas or secondary containers.

Material Inventory Practices

An up-to-date materials inventory can keep material costs down by preventing overstocking, track how materials are stored and handled onsite, and identify which materials and activities pose the most risk to the environment. Assign responsibility of hazardous material inventory to individuals trained to handle such materials. A material inventory should include these steps:

- Identify all chemical substances present at work site. Perform a walk-through of the site, review

purchase orders, list all chemical substances used and obtain Material Safety Data Sheets (MSDS) for all chemicals.

- Label all containers. Labels should provide name and type of substance, stock number, expiration date, health hazards, handling suggestions, and first aid information. Much of this information can be found on an MSDS.
- Clearly identify special handling, storage, use and disposal considerations for hazardous materials on the material inventory.
- Institute a shelf-life program to improve material tracking and inventory that can reduce the amount of materials that are overstocked and ensure proper disposal of expired materials. Careful tracking of materials ordered can result in more efficient materials use. Decisions on the amounts of hazardous materials that are stored on site should include an evaluation of any emergency control systems that are in place. All storage areas for hazardous materials should be designed to contain spills.

Training and Participation

Frequent and proper training in good housekeeping techniques reduces the likelihood that chemicals or equipment will be mishandled. To promote good housekeeping, consider implementing these practices:

- Discuss good housekeeping practices in training programs and meetings.
- Publicize pollution prevention concepts through posters or signs.
- Post bulletin boards with updated good housekeeping procedures, tips and reminders.

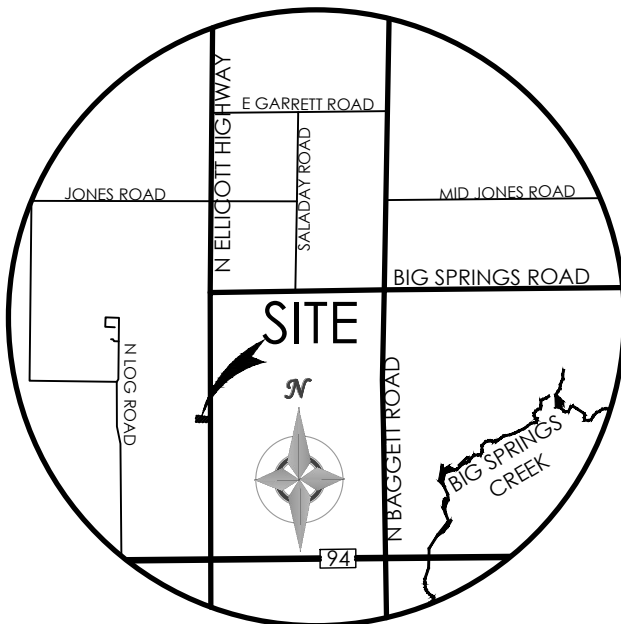
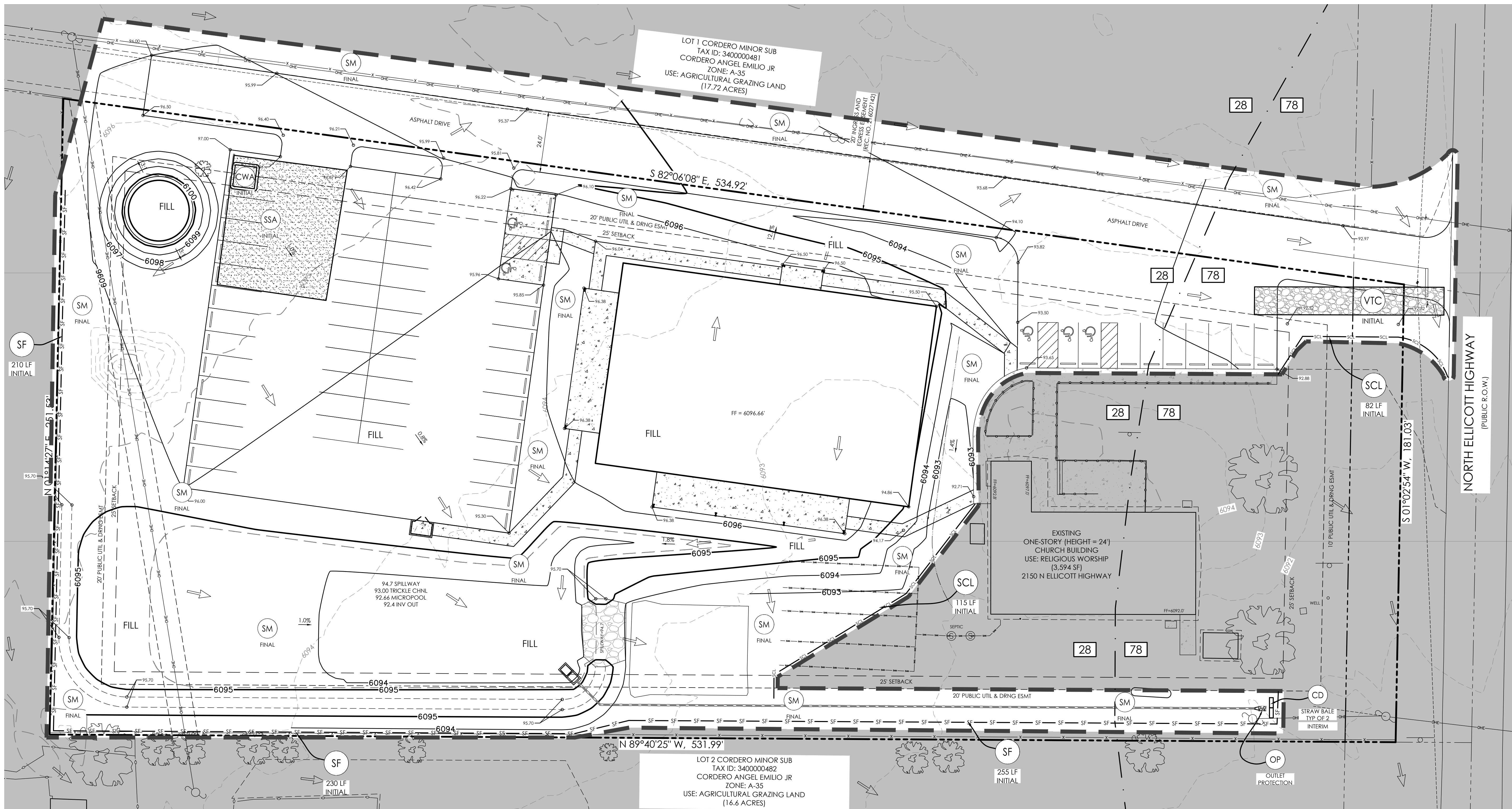

VICINITY MAP
NOT TO SCALE

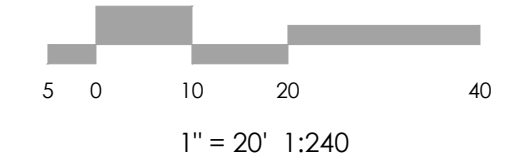
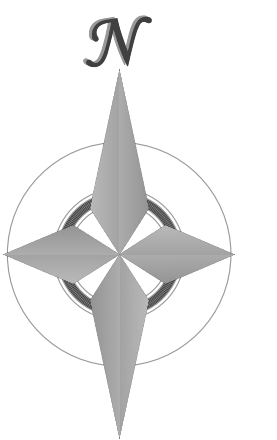

MVE, INC.
ENGINEERS & SURVEYORS

1903 Library Street, Suite 200 Colorado Springs, CO 80909 719.635.5726

REVISIONS

CM LEGEND

MAP SYMBOL	KEY	DESCRIPTION
INITIAL CMs		
	SSA	STABILIZED STAGING AREA (Initial CM)
	SCL	SEDIMENT CONTROL LOG (Initial/INTERIM CM)
	VTC	VEHICLE TRACKING CONTROL (Initial CM)
	CD	CHECK DAM (Initial CM)
	SF	SILT FENCE (Initial CM)
	TSB	TEMPORARY SEDIMENT BASIN (INITIAL CM)
	SSB	STRAW BALE BARRIER (INITIAL CM)
	CWA	CONCRETE WASHOUT AREA (INITIAL CM)
INTERIM/FINAL CMs		
	OP	OUTLET PROTECTION (RIP-RAP) (INTERIM/FINAL CM)
	CIP	CULVERT INLET PROTECTION (INTERIM CM)
	SM	SEEDING & MULCHING (FINAL CM)
	1.50%	SLOPE DIRECTION AND GRADE
	CUT/FILL	CUT/FILL BOUNDARY
		DRAINAGE FLOW ARROW
		LIMITS OF DISTURBANCE/ LIMITS OF CONSTRUCTION
		LIMITS OF DISTURBANCE LINE
		SOILTYPE BOUNDARY

OTHER DATA

LAT/LONG COORDS: 38°51'40.82" / 104°23'18.46"

VEGETATION:
EXISTING: NATIVE PRAIRIE GRASSES & WEEDS,
PROPOSED: RESEEDING DISTURBED AREAS

BATCH PLANTS: NONE

DEWATERING: NONE

DISTURBED AREA: 2.5± ACRES

RECEIVING WATERS: BLACK SQUIRREL CREEK

SCHEDULE: SUMMER 2025 - FALL 2025
FINAL STABILIZATION SPRING 2026

HYDROLOGIC SOIL GROUP

MAP UNIT NUMBER	DESCRIPTION
28	ELLICOTT LOAMY COARSE SAND, 0 TO 5% SLOPES
78	SAMPSON LOAM, 0 TO 3% SLOPES

SOIL DATA

PRIMARY SOIL DESCRIPTION	ELLICOTT LOAMY COARSE SAND, 0 TO 5% SLOPES	PRIMARY SOIL DESCRIPTION	SAMPSON LOAM, 0 TO 3% SLOPES
PERMEABILITY	RAPID	PERMEABILITY	MODERATE
SURFACE RUNOFF	SLOW	SURFACE RUNOFF	SLOW
HAZARD OF EROSION	HIGH	HAZARD OF EROSION	SLIGHT
HYDROLOGIC SOIL GROUP	A	HYDROLOGIC SOIL GROUP	B

SYMBOLS SHOWN IN LEGEND SHALL BE USED BY SWMP ADMINISTRATOR TO ANNOTATE ANY CHANGES AND/OR ADDITIONS TO THIS PLAN.

DESIGNED BY _____
DRAWN BY _____
CHECKED BY _____
AS-BUILTS BY _____
CHECKED BY _____

ROCKY MOUNTAIN CALVARY
CHAPEL - ELLICOTT

GRADING & EROSION CONTROL PLAN
EROSION CONTROL

C1.4 MVE PROJECT 61182
MVE DRAWING GEC-EC

FEBRUARY 19, 2025
SHEET 4 OF 5

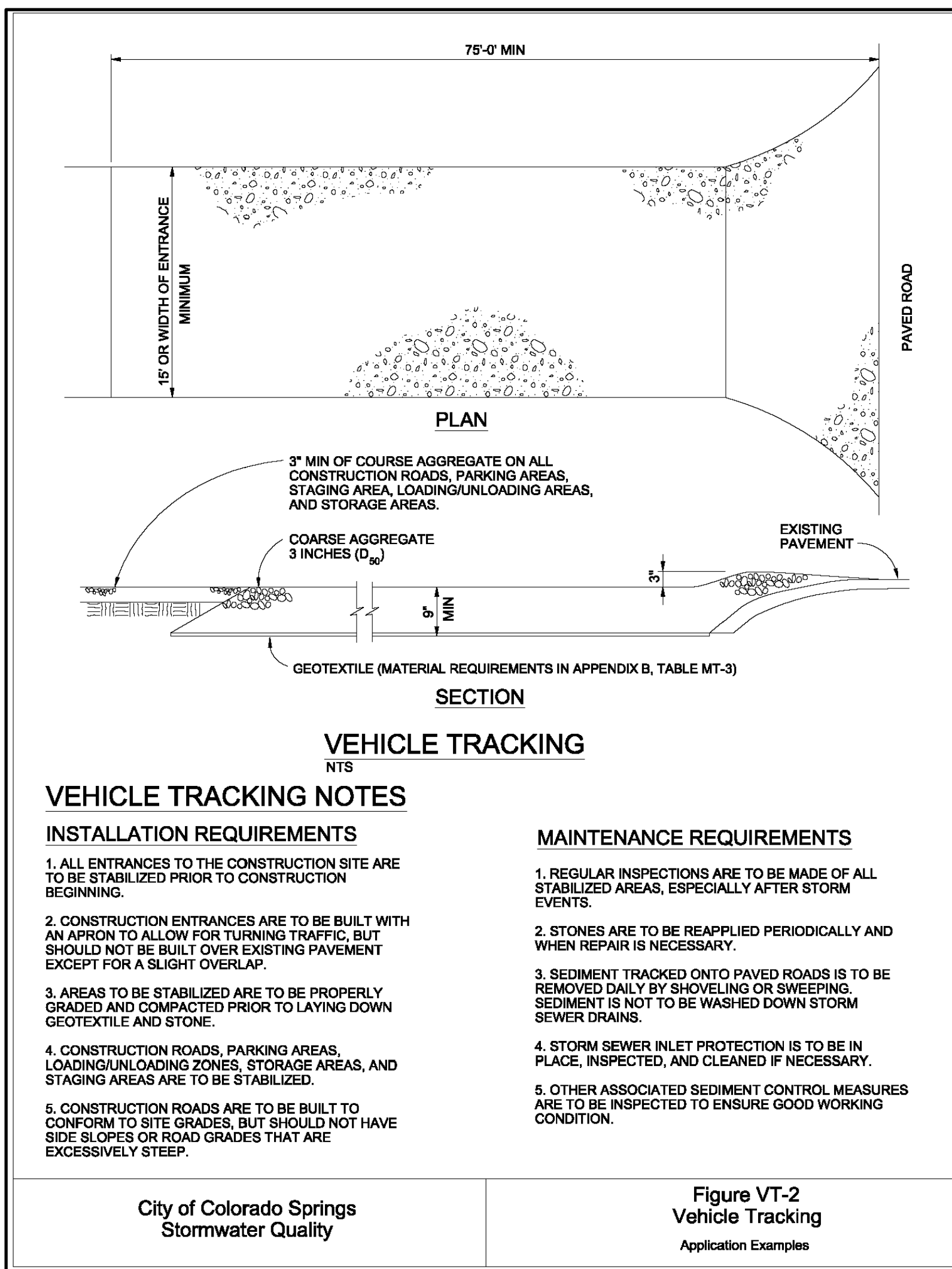

VEHICLE TRACKING NOTES

INSTALLATION REQUIREMENTS

1. ALL ENTRANCES TO THE CONSTRUCTION SITE ARE TO BE STABILIZED PRIOR TO CONSTRUCTION BEGINNING.
2. CONSTRUCTION ENTRANCES ARE TO BE BUILT WITH AN APRON TO ALLOW FOR TURNING TRAFFIC, BUT SHOULD NOT BE BUILT OVER EXISTING PAVEMENT EXCEPT FOR A SLIGHT OVERLAP.
3. AREAS TO BE STABILIZED ARE TO BE PROPERLY GRADED AND COMPACTED PRIOR TO LAYING DOWN GEOTEXTILE AND STONE.
4. CONSTRUCTION ROADS, PARKING AREAS, LOADING/UNLOADING ZONES, STORAGE AREAS, AND STAGING AREAS ARE TO BE STABILIZED.
5. CONSTRUCTION ROADS ARE TO BE BUILT TO CONFORM TO SITE GRADES, BUT SHOULD NOT HAVE SIDE SLOPES OR ROAD GRADES THAT ARE EXCESSIVELY STEEP.

MAINTENANCE REQUIREMENTS

1. REGULAR INSPECTIONS ARE TO BE MADE OF ALL STABILIZED AREAS, ESPECIALLY AFTER STORM EVENTS.
2. STONES ARE TO BE REAPPLIED PERIODICALLY AND WHEN REPAIR IS NECESSARY.
3. SEDIMENT TRACKED ONTO PAVED ROADS IS TO BE REMOVED DAILY BY SHOVELING OR SWEEPING. SEDIMENT IS NOT TO BE WASHED DOWN STORM SEWER DRAINS.
4. STORM SEWER INLET PROTECTION IS TO BE IN PLACE, INSPECTED, AND CLEANED IF NECESSARY.
5. OTHER ASSOCIATED SEDIMENT CONTROL MEASURES ARE TO BE INSPECTED TO ENSURE GOOD WORKING CONDITION.

City of Colorado Springs
Stormwater Quality

Figure VT-2
Vehicle Tracking
Application Examples

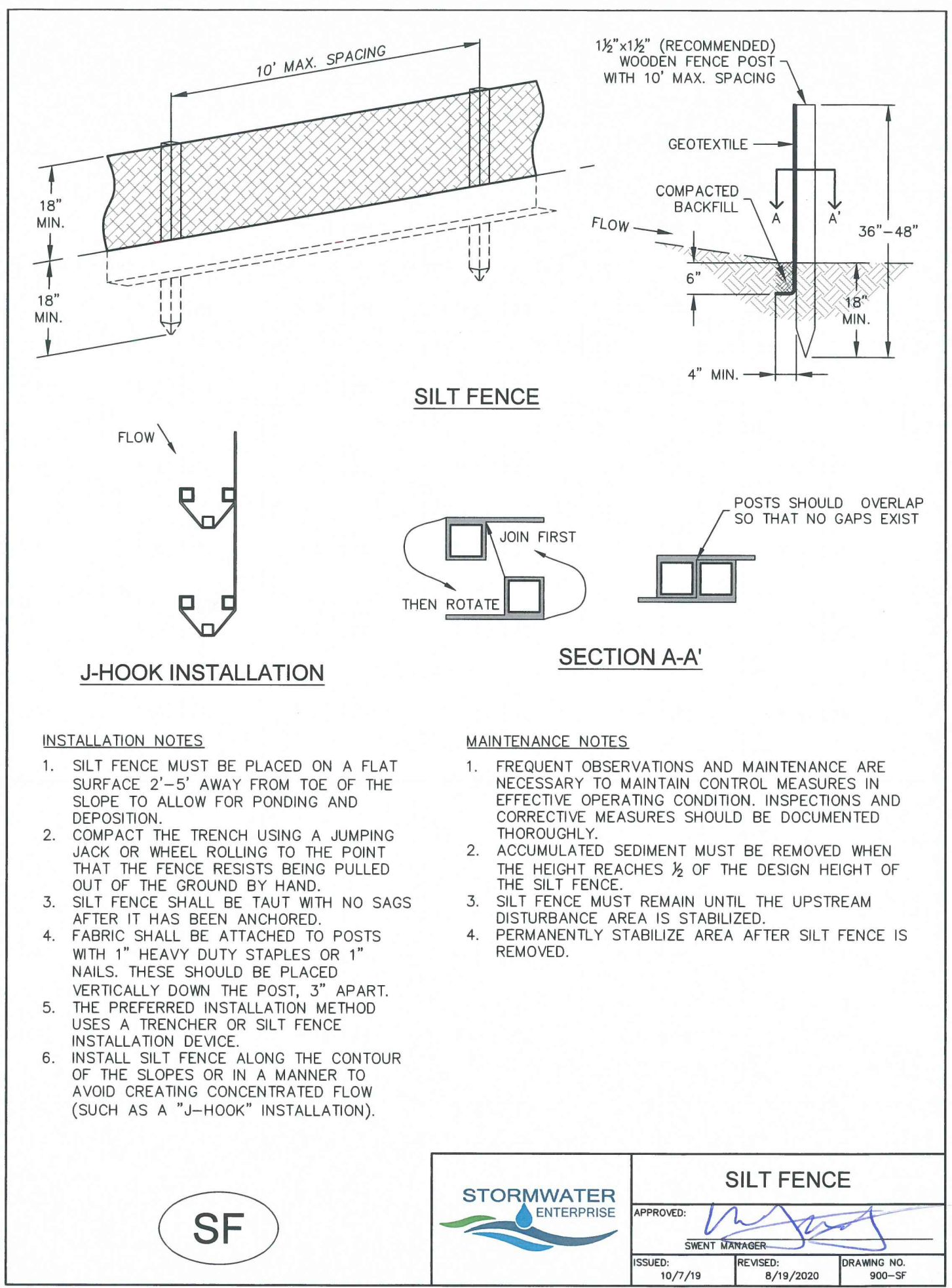

INSTALLATION NOTES

1. SILT FENCE MUST BE PLACED ON A FLAT SURFACE 2'-5' AWAY FROM TOE OF THE SLOPE TO ALLOW FOR PONDING AND DEPOSITION.
2. COMPACT THE TRENCH USING A JUMPING JACK OR WHEEL ROLLING TO THE POINT THAT THE FENCE RESISTS BEING PULLED OUT OF THE GROUND BY HAND.
3. SILT FENCE SHALL BE TAUT WITH NO SAGS AFTER IT HAS BEEN ANCHORED.
4. FABRIC SHALL BE ATTACHED TO POSTS WITH 1" HEAVY DUTY STAPLES OR 1" NAILS. THESE SHOULD BE PLACED VERTICALLY DOWN THE POST, 3" APART.
5. THE PREFERRED INSTALLATION METHOD USES A TRENCHER OR SILT FENCE INSTALLATION DEVICE.
6. INSTALL SILT FENCE ALONG THE CONTOUR OF THE SLOPES OR IN A MANNER TO AVOID CREATING CONCENTRATED FLOW (SUCH AS A "J-HOOK" INSTALLATION).

MAINTENANCE NOTES

1. FREQUENT OBSERVATIONS AND MAINTENANCE ARE NECESSARY TO MAINTAIN CONTROL MEASURES IN EFFECTIVE OPERATING CONDITION. INSPECTIONS AND CORRECTIVE MEASURES SHOULD BE DOCUMENTED THOROUGHLY.
2. ACCUMULATED SEDIMENT MUST BE REMOVED WHEN THE HEIGHT REACHES 1/2 OF THE DESIGN HEIGHT OF THE SILT FENCE.
3. SILT FENCE MUST REMAIN UNTIL THE UPSTREAM DISTURBANCE AREA IS STABILIZED.
4. PERMANENTLY STABILIZE AREA AFTER SILT FENCE IS REMOVED.

SILT FENCE

APPROVED: [Signature]

ISSUED: 10/7/19 REVISED: 8/19/2020 DRAWING NO. 900-SF

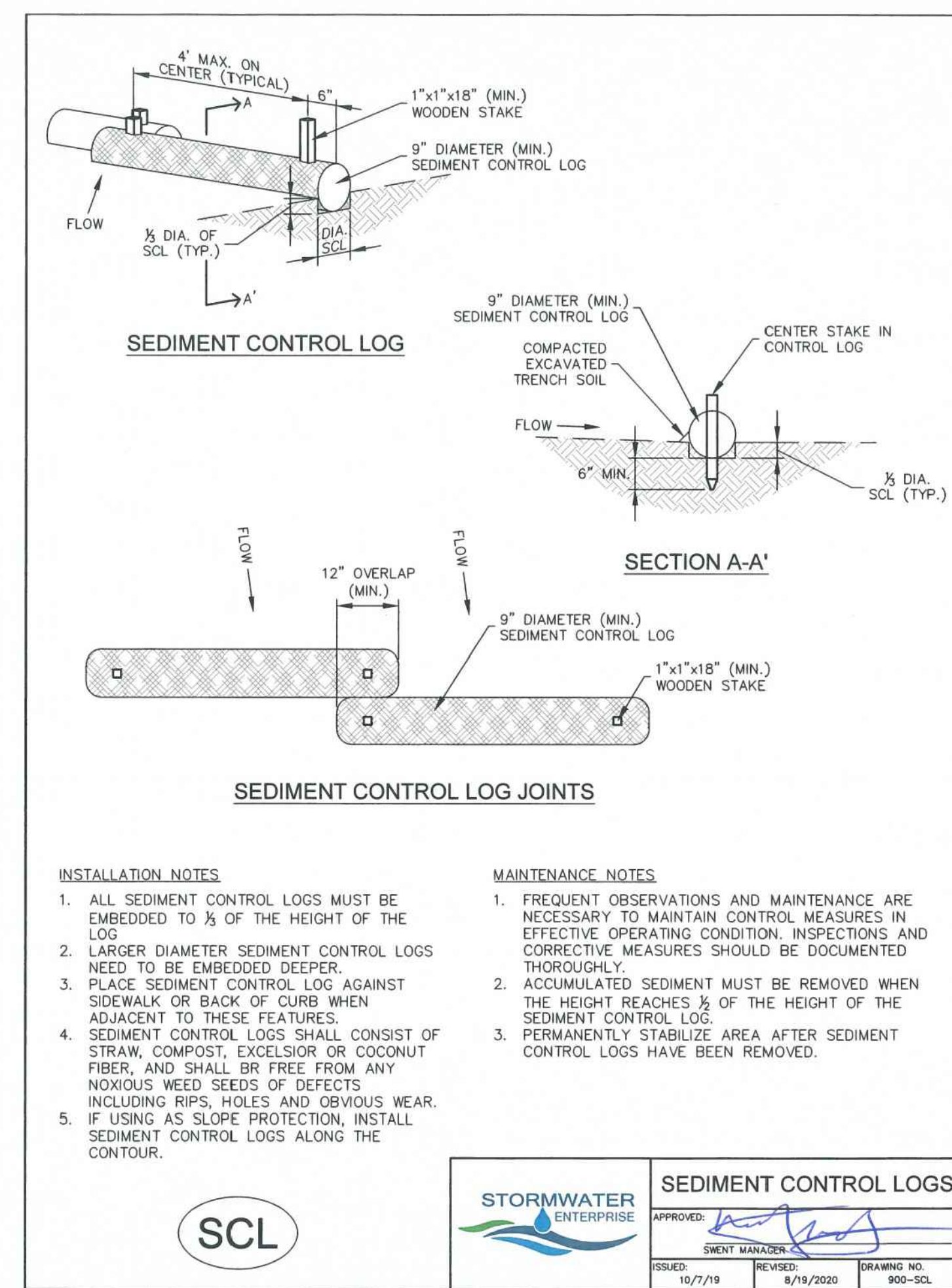

INSTALLATION NOTES

1. ALL SEDIMENT CONTROL LOGS MUST BE EMBEDDED TO 1/2 OF THE HEIGHT OF THE LOG.
2. LARGER DIAMETER SEDIMENT CONTROL LOGS NEED TO BE EMBEDDED DEEPER.
3. PLACE SEDIMENT CONTROL LOG AGAINST SIDEWALK OR BACK OF CURB WHEN ADJACENT TO THESE FEATURES.
4. SEDIMENT CONTROL LOGS SHALL CONSIST OF STRAW, COMPOST, EXCELSIOR OR COCONUT FIBER, AND SHALL BE FREE FROM ANY NOXIOUS WEED SEEDS OF DEFECTS INCLUDING RIPS, HOLES AND OBVIOUS WEAR.
5. IF USING AS SLOPE PROTECTION, INSTALL SEDIMENT CONTROL LOGS ALONG THE CONTOUR.

MAINTENANCE NOTES

1. FREQUENT OBSERVATIONS AND MAINTENANCE ARE NECESSARY TO MAINTAIN CONTROL MEASURES IN EFFECTIVE OPERATING CONDITION. INSPECTIONS AND CORRECTIVE MEASURES SHOULD BE DOCUMENTED THOROUGHLY.
2. ACCUMULATED SEDIMENT MUST BE REMOVED WHEN THE HEIGHT REACHES 1/2 OF THE HEIGHT OF THE SEDIMENT CONTROL LOG.
3. PERMANENTLY STABILIZE AREA AFTER SEDIMENT CONTROL LOGS HAVE BEEN REMOVED.

SEDIMENT CONTROL LOGS

APPROVED: [Signature]

ISSUED: 10/7/19 REVISED: 8/19/2020 DRAWING NO. 900-SCL

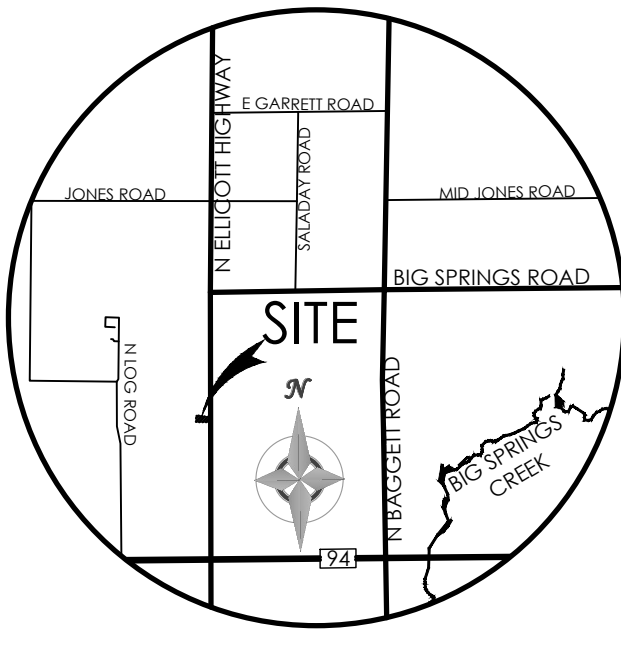

VICINITY MAP
NOT TO SCALE

BENCHMARK

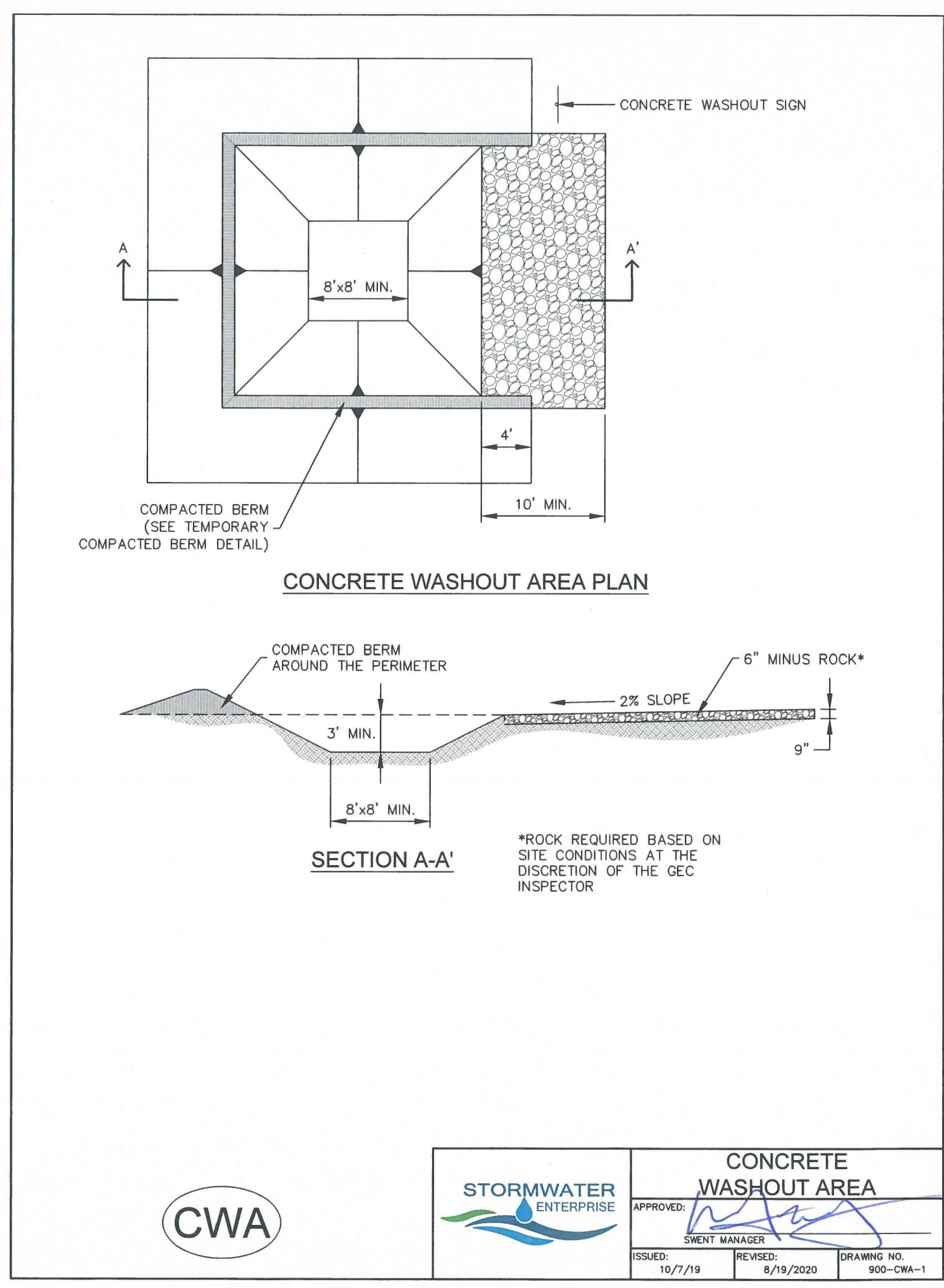

INSTALLATION NOTES

1. SEE PLAN VIEW FOR: -LOCATION OF CONCRETE WASHOUT AREA
2. LOCATE AT LEAST 50' AWAY FROM STATE WATERS MEASURED HORIZONTALLY.
3. AN IMPERMEABLE LINER (16 MIL. MINIMUM THICKNESS) IS REQUIRED IF CONCRETE WASH AREA IS LOCATED WITHIN 400' OF STATE WATERS OR 1000' OF WELLS OR DRINKING WATER SOURCES.
4. DO NOT LOCATE IN AREAS WHERE SHALLOW GROUNDWATER MAY BE PRESENT.
5. THE CONCRETE WASH AREA SHALL BE INSTALLED PRIOR TO CONCRETE PLACEMENT ON SITE.
6. CONCRETE WASH AREA SHALL INCLUDE A FLAT SUBSURFACE PIT THAT IS AT LEAST 8' BY 8'.
7. BERM SURROUNDING SIDES AND BACK OF CONCRETE WASH AREA SHALL HAVE A MINIMUM HEIGHT OF 2 FEET.
8. CONCRETE WASH AREA ENTRANCE SHALL BE SLOPED 2% TOWARDS THE CONCRETE WASH AREA.
9. SIGNS SHALL BE PLACED AT THE CONCRETE WASH AREA.
10. USE EXCAVATED MATERIAL FOR PERIMETER BERM CONSTRUCTION.

MAINTENANCE NOTES

1. FREQUENT OBSERVATIONS AND MAINTENANCE ARE NECESSARY TO MAINTAIN CONTROL MEASURES IN EFFECTIVE OPERATING CONDITION. INSPECTIONS AND CORRECTIVE MEASURES SHOULD BE DOCUMENTED THOROUGHLY.
2. THE CONCRETE WASH AREA SHALL BE REPAIRED, CLEANED, OR ENLARGED AS NECESSARY TO MAINTAIN CAPACITY FOR CONCRETE WASTE. CONCRETE MATERIALS ACCUMULATED IN THE PIT SHALL BE REMOVED ONCE THE MATERIALS HAVE REACHED A DEPTH OF 1/2 THE HEIGHT OF THE CONCRETE WASH AREA.
3. CONCRETE WASHOUT WATER, WASTED PIECES OF CONCRETE, AND ALL OTHER DEBRIS IN THE SUBSURFACE PIT SHALL BE TRANSPORTED FROM THE JOB SITE IN A WATER-TIGHT CONTAINER AND DISPOSED OF PROPERLY.
4. THE CONCRETE WASH AREA SHALL REMAIN IN PLACE UNTIL ALL CONCRETE FOR THE PROJECT IS PLACED.
5. PERMANENTLY STABILIZE AREA AFTER CONCRETE WASH AREA IS REMOVED.

CONCRETE WASHOUT AREA

APPROVED: [Signature]

ISSUED: 10/7/19 REVISED: 8/19/2020 DRAWING NO. 900-CWA-1

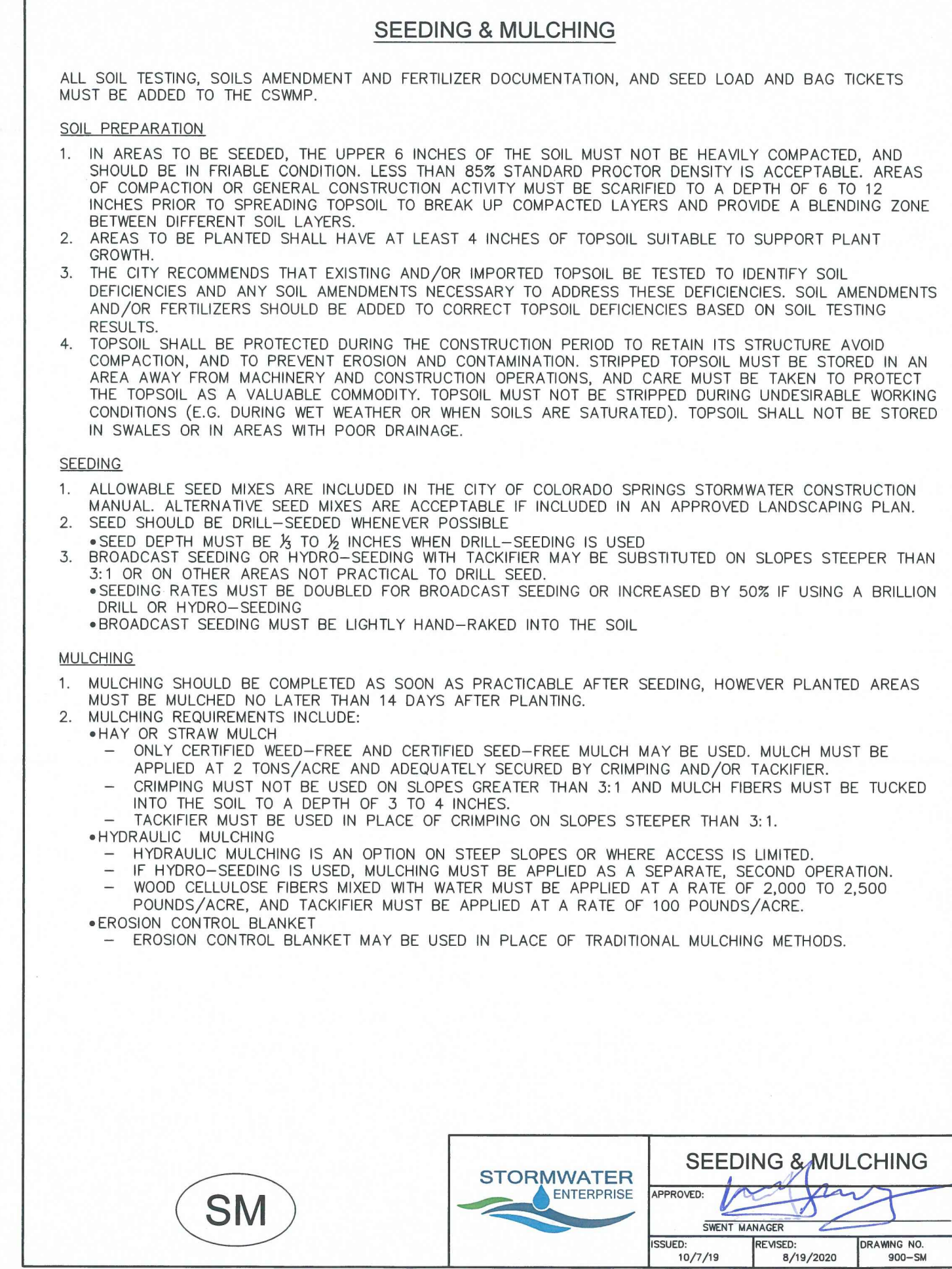

SEEDING & MULCHING

ALL SOIL TESTING, SOILS AMENDMENT AND FERTILIZER DOCUMENTATION, AND SEED LOAD AND BAG TICKETS MUST BE ADDED TO THE CSWMP.

SOIL PREPARATION

1. IN AREAS TO BE SEED, THE UPPER 6 INCHES OF THE SOIL MUST NOT BE HEAVILY COMPACTED, AND SHOULD BE IN FRIABLE CONDITION. LESS THAN 85% STANDARD PROCTOR DENSITY IS ACCEPTABLE. AREAS OF COMPACTION OR GENERAL CONSTRUCTION ACTIVITY MUST BE SCARIFIED TO A DEPTH OF 6 TO 12 INCHES PRIOR TO SPREADING TOPSOIL TO BREAK UP COMPACTED LAYERS AND PROVIDE A BLENDING ZONE BETWEEN DIFFERENT SOIL LAYERS.
2. AREAS TO BE PLANTED SHALL HAVE AT LEAST 4 INCHES OF TOPSOIL SUITABLE TO SUPPORT PLANT GROWTH.
3. THE CITY RECOMMENDS THAT EXISTING AND/OR IMPORTED TOPSOIL BE TESTED TO IDENTIFY SOIL DEFICIENCIES AND ANY SOIL AMENDMENTS NECESSARY TO ADDRESS THESE DEFICIENCIES. SOIL AMENDMENTS AND/OR FERTILIZERS SHOULD BE ADDED TO CORRECT TOPSOIL DEFICIENCIES BASED ON SOIL TESTING RESULTS.
4. TOPSOIL SHALL BE PROTECTED DURING THE CONSTRUCTION PERIOD TO RETAIN ITS STRUCTURE AVOID COMPACTION, AND TO PREVENT EROSION AND CONTAMINATION. STRIPPED TOPSOIL MUST BE STORED IN AN AREA AWAY FROM MACHINERY AND CONSTRUCTION OPERATIONS, AND CARE MUST BE TAKEN TO PROTECT THE TOPSOIL AS A VALUABLE COMMODITY. TOPSOIL MUST NOT BE STRIPPED DURING UNDESIRABLE WORKING CONDITIONS (E.G. DURING WET WEATHER OR WHEN SOILS ARE SATURATED). TOPSOIL SHALL NOT BE STORED IN SWALES OR IN AREAS WITH POOR DRAINAGE.

SEEDING

1. ALLOWABLE SEED MIXES ARE INCLUDED IN THE CITY OF COLORADO SPRINGS STORMWATER CONSTRUCTION MANUAL. ALTERNATIVE SEED MIXES ARE ACCEPTABLE IF INCLUDED IN AN APPROVED LANDSCAPING PLAN.
2. SEED SHOULD BE DRILL-SEEDED WHENEVER POSSIBLE.
3. SEED DEPTH MUST BE 1/2 TO 3/4 INCHES WHEN DRILL-SEEDED. BROADCAST SEEDING OR HYDRO-SEEDED WITH TACKIFIER MAY BE SUBSTITUTED ON SLOPES STEEPER THAN 3:1 OR ON OTHER AREAS NOT PRACTICAL TO DRILL SEED.
4. SEEDING RATES MUST BE DOUBLED FOR BROADCAST SEEDING OR INCREASED BY 50% IF USING A BRILLION DRILL OR HYDRO-SEEDED.
5. BROADCAST SEEDING MUST BE LIGHTLY HAND-RAKED INTO THE SOIL.

MULCHING

1. MULCHING SHOULD BE COMPLETED AS SOON AS PRACTICABLE AFTER SEEDING, HOWEVER PLANTED AREAS MUST BE MULCHED NO LATER THAN 14 DAYS AFTER PLANTING.
2. MULCHING REQUIREMENTS INCLUDE:
 - HAY OR STRAW MULCH
 - ONLY CERTIFIED WEED-FREE AND CERTIFIED SEED-FREE MULCH MAY BE USED. MULCH MUST BE APPLIED AT 2 TONS/ACRE AND ADEQUATELY SECURED BY CRIMPING AND/OR TACKIFIER.
 - CRIMPING MUST NOT BE USED ON SLOPES GREATER THAN 3:1 AND MULCH FIBERS MUST BE TUCKED INTO THE SOIL TO A DEPTH OF 3 TO 4 INCHES.
 - TACKIFIER MUST BE USED IN PLACE OF CRIMPING ON SLOPES STEEPER THAN 3:1.
3. HYDRAULIC MULCHING
 - HYDRAULIC MULCHING IS AN OPTION ON STEEP SLOPES OR WHERE ACCESS IS LIMITED.
 - IF HYDRO-SEEDED IS USED, MULCHING MUST BE APPLIED AS A SEPARATE, SECOND OPERATION.
 - WOOD CELLULOSE FIBERS MIXED WITH WATER MUST BE APPLIED AT A RATE OF 2,000 TO 2,500 POUNDS/ACRE, AND TACKIFIER MUST BE APPLIED AT A RATE OF 100 POUNDS/ACRE.
4. EROSION CONTROL BLANKET
 - EROSION CONTROL BLANKET MAY BE USED IN PLACE OF TRADITIONAL MULCHING METHODS.

SEEDING & MULCHING

APPROVED: [Signature]

ISSUED: 10/7/19 REVISED: 8/19/2020 DRAWING NO. 900-SM



REVISIONS

DESIGNED BY _____
DRAWN BY _____
CHECKED BY _____
AS-BUILTS BY _____
CHECKED BY _____

ROCKY MOUNTAIN LIMITED
CHAPEL - ELLICOTT

GRADING & EROSION
CONTROL PLAN
EROSION CONTROL DET

C1.5 MVE PROJECT 61182
MVE DRAWING GEC-ED

FEBRUARY 19, 2025
SHEET 5 OF 5