



INNOVATIVE DESIGN. CLASSIC RESULTS.

**PRELIMINARY/FINAL DRAINAGE REPORT**

**MIDTOWN COLLECTION AT HANNAH RIDGE**  
**FILING No. 3**  
**(A Replat of Tract CC, Hannah Ridge at**  
**Feathergrass Subdivision Filing No. 1)**  
**PUDSP-20-007**

**DECEMBER 2021**

Prepared for:  
**ELITE PROPERTIES OF AMERICA, INC.**  
**2138 FLYING HORSE CLUB DRIVE**  
**COLORADO SPRINGS, CO 80921**

Prepared by:  
**CLASSIC CONSULTING ENGINEERS & SURVEYORS**  
**619 CASCADE AVENUE, SUITE 200**  
**COLORADO SPRINGS, CO 80903**  
**(719) 785-0790**

Job no. 1116.35



**PRELIMINARY/FINAL DRAINAGE REPORT FOR MIDTOWN COLLECTION AT HANNAH RIDGE FILING NO. 3 (A Replat of Tract CC, Hannah Ridge at Feathergrass Subdivision Filing No. 1)**

**DRAINAGE REPORT STATEMENT**

**DESIGN ENGINEER'S STATEMENT:**

The attached drainage plan and report were prepared under my direction and supervision and are correct to the best of my knowledge and belief. Said drainage report has been prepared according to the criteria established by the County for drainage reports and said report is in conformity with the applicable master plan of the drainage basin. I accept responsibility for any liability caused by any negligent acts, errors or omissions of my part in preparing this report.



\_\_\_\_\_  
Kyle R. Campbell, Colorado P.E. #

03/17/2022  
Date

**OWNERS/DEVELOPER'S STATEMENT:**

I, the owner/developer, have read and will comply with all of the requirements specified in this drainage report and plan.

Business Name: Elite Properties of America, Inc.

*Jim Boulton*

12/13/21  
Date

Title: Vice President

Address: 2138 Flying Horse Club Drive

Colorado Springs, CO 80921

**EL PASO COUNTY:**

Filed in accordance with the requirements of the Drainage Criteria Manual, Volumes 1 and 2, El Paso County Engineering Criteria Manual and Land Development Code, as amended.

\_\_\_\_\_  
Jennifer Irvine, P.E.  
County Engineer / ECM Administrator

\_\_\_\_\_  
Date

Conditions:



**PRELIMINARY/FINAL DRAINAGE REPORT FOR MIDTOWN COLLECTION AT HANNAH RIDGE FILING NO. 3 (A Replat of Tract CC, Hannah Ridge at Feathergrass Subdivision Filing No. 1)**

**TABLE OF CONTENTS:**

|                                |         |
|--------------------------------|---------|
| PURPOSE                        | Page 4  |
| GENERAL DESCRIPTION            | Page 4  |
| EXISTING DRAINAGE CONDITIONS   | Page 5  |
| DEVELOPED DRAINAGE CONDITIONS  | Page 5  |
| HYDROLOGIC CALCULATIONS        | Page 10 |
| FLOODPLAIN STATEMENT           | Page 11 |
| EROSION CONTROL PLAN           | Page 11 |
| DRAINAGE FACILITY COST OPINION | Page 12 |
| DRAINAGE AND BRIDGE FEES       | Page 13 |
| SUMMARY                        | Page 14 |
| REFERENCES                     | Page 15 |

**APPENDICES**

|  |
|--|
| VICINITY MAP   |
| SOILS MAP (S.C.S. SURVEY)  |
| F.E.M.A. MAP   |
| REFERENCE MATERIAL FROM ADJACENT STUDIES EXISTING CONDITIONS DRAINAGE MAP AND CALCULATIONS |
| HYDROLOGIC / HYDRAULIC CALCULATIONS  |
| SWQ / FULL SPECTRUM DETENTION CALCULATIONS   |
| REIMBURSABLE COST SUMMARY  |
| DRAINAGE MAPS  |



## **PURPOSE**

This document is the Preliminary and Final Drainage Report for Midtown Collection at Hannah Ridge Filing No. 3. The purpose of this report is to identify onsite and offsite drainage patterns, storm sewer, inlet locations, and areas tributary to the site, and to safely route developed storm water runoff to adequate detention and water quality facilities while releasing storm water at or below historic rates and in accordance with all applicable master drainage plans. This report will discuss the proposed storm system to be built with Filing 3 and discuss the construction details, and more specifically, the design details of the proposed sub-regional public detention/water quality facility located within Filing 3 that will handle the treatment for this site as well as Hannah Ridge at Feathergrass Filings No. 1 & 2. Design information for the Filing No. 3 detention/water quality facility is included in this report.

It is anticipated that an amendment to this report will be provided when the Final Plat and Construction Drawings details are processed for review.

## **GENERAL DESCRIPTION**

The overall Hannah Ridge at Feathergrass development is a 121.2 acre residential and commercial district within the south half of Section 32, Township 13 South, Range 65 West of the 6<sup>th</sup> Principal Meridian in El Paso County, Colorado. The site is located on the west side of Akers Drive just north of Constitution Avenue. The existing abandoned Chicago Rock Island and Pacific Railroad sits directly north and west of the site, with Akers Drive bordering the east side and Constitution adjoining the south side of the site. The development includes a total of 345 single-family residences that will be developed in seven filings, as well as two small lot PUD single family developments and one commercial parcel, Tract CC. Tract CC is now proposed for a small lot PUD single family development which is prompting the PUD rezone and PUD site plan applications. Midtown Collection at Hannah Ridge Filing No. 3 (Tract CC) is 7.44 acres in size and contains 42 proposed small lot, single-family detached lots.

The average soil condition of the entire site and tributary area to the proposed ponds reflects Hydrologic Group "A" (Blakeland, loamy sand) as determined by the "Soil Survey of El Paso County Area," prepared by the National Cooperative Soil Survey (see map in Appendix).



## **EXISTING DRAINAGE CONDITIONS**

The site is located within the Sand Creek Drainage Basin. More specifically, it is situated in the far southeast portion of the overall Hannah Ridge at Feathergrass development. This site was previously studied in the “Final Drainage Report for Hannah Ridge at Feathergrass Subdivision Filing No. 1”, by MVE, Inc. dated January 2014 this proposed residential filing is located in Basin D9, D11 and G1 from the Filing No. 1 report as shown on the developed drainage map provided by MVE, Inc. (See Appendix). Existing Hannah Ridge Drive along the west edge of the development serves as the westerly basin boundary and Hunter Jumper Drive to the north as the northerly basin boundary. The construction of Hannah Ridge at Feathergrass Filing 1 and 2 improvements included the public storm under Hunter Jumper Drive and Hannah Ridge Drive out-falling into the existing drainageway that runs parallel to Constitution. The 84” RCP public storm from Hunter Jumper Drive to Hannah Ridge Drive was previously constructed. The on-site pre-development drainage patterns are generally sheet flowing towards Constitution Avenue where existing inlets intercept the flows and transfer them to an existing stormwater quality only facility located on the east side of Hannah Ridge Drive also constructed with Filing No. 1 and Filing No. 2. Filing No. 1 existing flows generally drain as street flow in a westerly direction towards the existing public drainage facilities within Hannah Ridge Drive. The prior report anticipated released of fully developed flows downstream into the dual cell box culverts under Constitution Avenue.

## **DEVELOPED DRAINAGE CONDITIONS**

Based upon City/County Drainage Criteria, the drainage approach for this development now reflects current criteria for stormwater quality and Full Spectrum Detention requirements. The existing pond on the site will be redesigned as a Full Spectrum facility to accommodate the development of this site and all of northerly Hannah Ridge at Feathergrass Filing 1 and portions of Filing No. 2. This will include the design of concrete forebays, concrete trickle channels, concrete micro-pool and an outlet structure designed to release flows based on full spectrum criteria. The attached developed conditions drainage map contains the design points related to proposed sump conditions. All public and private Type R inlets have been designed at these various locations to accept both the 5-yr. and 100-yr. developed flows.

All proposed storm facilities within the public Right-of-way will be public with ownership and maintenance by El Paso County. All other proposed storm facilities are either public or private (as labeled on map and described below) and are within easements or tracts. The proposed modified Pond 1 will be owned and maintained by the Hannah Ridge Midtown Collection HOA. All existing public storm facilities are located within existing easements as reflected on the drainage map.

**Design Point 1** ( $Q_5 = 1.9$  cfs and  $Q_{100} = 4.1$  cfs) is comprised of 0.76 acres of proposed on-site developed flows from Basin A. These single-family lots and private street flows travel west to the proposed intersection at Equine Court. The flows are intercepted by a 6' cross pan and routed south into Basin B-1 along the east side of proposed public Equine Court.

**Design Point 2** ( $Q_5 = 4.3$  cfs and  $Q_{100} = 10.5$  cfs) collects developed flows from Basin B-1 and C and the flows from Design Point 1. Basin B-1 ( $Q_5 = 2.6$  cfs and  $Q_{100} = 15.8$  cfs) and C ( $Q_5 = 0.9$  cfs and  $Q_{100} = 1.7$  cfs) flows are comprised of proposed single-family homes and public and private street flows. At this sump condition, a 10' public Type R sump inlet will be installed to completely collect both the 5-year and 100-year developed flows. These flows will have a maximum ponding depth of 6 inches and will then be conveyed via a 24" RCP public storm sewer in a northerly direction towards the Tract A Pond. The total flow within the pipe at this location is given by **Pipe Run 2 ( $Q_5 = 5.0$  cfs and  $Q_{100} = 12.0$  cfs)** which includes flows from Design Point 4 ( $Q_5 = 0.8$  cfs and  $Q_{100} = 1.7$  cfs), a small 0.34-acre basin of a portion of 7 proposed lots and landscape area. The emergency overflow route at Design Point 2 is in the southerly direction directly into the southerly drainage channel that will route the flows south under Constitution Avenue.

**Design Point 3** ( $Q_5 = 3.1$  cfs and  $Q_{100} = 6.2$  cfs) is developed flows from Basin D, 1.08 acres of proposed single-family homes and public and private street flows. At this sump condition, a 10' private Type R private sump inlet, will be installed to completely collect both the 5-year and 100-year developed flows. These flows will have a maximum ponding depth of 6 inches and then be conveyed via an 18" PVC or ADS private storm sewer towards the Tract A Pond. The total flow within the pipe at this location is given by **Pipe Run 3 ( $Q_5 = 3.1$  cfs and  $Q_{100} = 6.2$  cfs)**. The emergency overflow route at this location is south directly into the proposed expanded Pond.

**Design Point 5** ( $Q_5 = 27.2$  cfs and  $Q_{100} = 53.5$  cfs) represents the combined pipe flows from Design Points 3 and all northerly off-site developed flows (the southerly curb line along Hunter Jumper Drive west of proposed Equine Court, and the easterly curb line of Hannah Ridge Drive south of Hunter Jumper Drive and north of Constitution Avenue). A 48" RCP public storm sewer (**Pipe Run 4**) will route these combined developed flows directly into the Pond after being intercepted by an existing 15' public sump inlet.

**Design Point 4** ( $Q_5 = 0.8$  cfs and  $Q_{100} = 1.7$  cfs) collects developed flows from Basin B-2 (0.34 acres of a portion of seven homes and landscape area). At this sump condition, a private CDOT Type C sump grated inlet will be installed to completely collect both the 5-year and 100-year developed flows. These flows being collected have a maximum ponding depth of 0.13' and then be conveyed via a private 12" PVC or ADS storm sewer towards Design Point 2. The presence of a Froude number slightly more than 1.0 is not a concern for this landscape area with less than 2 inches of 100-year flow depth. The total flow within the pipe at this location is given by **Pipe Run 1** ( $Q_5 = 0.8$  cfs and  $Q_{100} = 1.7$  cfs). The emergency overflow route at this location is via Tract A directly into the drainage channel along Constitution.

**Basin E** ( $Q_5 = 2.1$  cfs and  $Q_{100} = 4.1$  cfs) are flows from a portion of 8 homes along Hunter Jumper Drive and landscape areas that drain into Hannah Ridge Drive and are collected by the existing public 15' Type R sump inlet and also routed to the expanded Tract A Pond.

Runoff from **Basin F** (1.23 Acres) ( $Q_5 = 1.5$  cfs and  $Q_{100} = 5.0$  cfs) and **Basin G** (1.87 Acres) ( $Q_5 = 1.2$  cfs and  $Q_{100} = 6.6$  cfs) flow directly into the proposed expanded pond or into the southerly drainage channel. The areas draining directly into the channel are comprised of the channel itself or directly tributary landscape areas.

**Basin H** ( $Q_5 = 0.2$  cfs and  $Q_{100} = 1.4$  cfs) is a small 0.42-acre landscape parcel at the southeast corner of the site that sheet flows directly into Akers Drive and Constitution Avenue similar to existing conditions. Basin H will remain undeveloped land without pavement or structures, therefore water quality is not required for this area per current El Paso County ECM.

**The total inflow into the expanded Pond is  $Q_5 = 34.7$  cfs and  $Q_{100} = 70.6$  cfs from both outfalls into the pond.** The total proposed flow into the pond is comprised of off-site existing developed Basins D-1, D-2, D-3, D-4, D-5, D-6, D-7, D-8, D-9, D-10 and D-12 (15.25 acres total). See Drainage Map from prior approved report in the Appendix. Runoff Coefficients used for this composite off-site are ( $Q_5 = 0.49$  cfs and  $Q_{100} = 0.57$  cfs). The existing facility will be expanded with the proposed Filing 3 development. This facility will have two inflow points. Both inflow points will outfall into proposed concrete forebays. The west inflow will be from a proposed 48" RCP into a proposed concrete forebay with a required size of .010 ac-ft based on 3% of the WQCV from this inflow. The forebay is designed with 12" high walls, 7.4" notch and a 30" wide concrete trickle channel routing the flows towards the pond outlet. The east inflow will be from a proposed 24" RCP into a proposed concrete forebay with a required size of .010 ac-ft based on 3% of the WQCV from this inflow. The forebay is designed with 12" high walls, 3.3" notch and a 30" wide concrete trickle channel routing the flows toward the pond outlet. The outlet structure consists of a 6'x5' concrete box with an integral 100 Square Foot micro-pool allowing for 6" initial surcharge depth. The micro-pool total depth of 2.5' provides the required 0.3% of the WQCV. The outlet box will have a height of 4.60' above the micro-pool water elevation. (See UD-BMP Spreadsheets in the Appendix). The orifice plate on the front of the outlet box consists of a series of 3 – 1 5/8" holes, 17.80" apart (see UD Detention Spreadsheets in Appendix) this facility will be owned and maintained by the Hannah Ridge Midtown Collection HOA.

**Pond 1** has the following design parameters as a Full Spectrum Facility:

0.331 Ac.-ft. WQCV required

0.677 Ac.-ft. EURV required

0.661Ac.-ft. 100-year storage required

|                                     |  |
|-------------------------------------|--|
| Pond Design Release:                | $Q_5 = 0.3$ cfs, $Q_{100} = 10.5$ cfs (Design Point 5) |
| Pre-development Release:            | $Q_5 = 0.4$ cfs, $Q_{100} = 16.6$ cfs                  |
| Maximum 100-Year Ponding Elevation: | 6448.22  |



An existing 24" HDPE storm pipe currently conveys the released flows and will continue to do so (Pipe Run Outfall). A 5' long by 3' wide rip-rap (Type VL) dissipator will be provided at the existing pipe outlet.

Hydrologic Soil Group A was used for FSD Calculations.

In the event of an emergency (outlet structure blockage or failure), an emergency spillway will convey flows from the pond in a southerly direction into the existing (and proposed to be improved) drainage channel. A proposed emergency spillway with a 65' wire base and 4:1 side slopes will convey the 10-5 cfs in a 100 year event. Buried soil rip-rap over compacted subbase is proposed. As this expanded facility is neither a sub-regional or regional facility, a cut off wall is not required per the DCM. See typical emergency spillway section on enclosed Proposed Conditions Drainage Map, and rip -rap sizing form (Type VL required) in appendix.

All existing storm infrastructure that will not be utilized due to the upstream off-site flows being redirected will be capped at the disconnect point. Details will be provided on future Construction Drawings detailing the location.

The release from the pond will be discharged into the proposed public improved drainage corridor that runs parallel to Constitution Avenue towards an existing public storm outfall under Constitution Avenue contained within multiple El Paso County public drainage easements per Book 5122 and, Page 995 and Rec. No. 214713468. With the public box culverts and headwalls under Hannah Ridge Drive (dual 6' x 10') and Constitution Avenue (dual 6' x 12') being existing, the only remaining public improvements between the existing public outlet and inlet is approximately 450 linear feet of public rip-rap trapezoidal channel. As defined in the DBPS as a Rip Rap channel with a bottom width of 30', depth of 4' and projected flow of 1,580 cfs in the 100-year event (DBPS segment number 12-A). The inclusion of on-site Full Spectrum Detention (not anticipated with DBPS flows) will decrease the amount flowing into the proposed channel corridor. The subsequent Hannah Ridge MDDP further defined the tributary flows and required channel improvement as approved within the Filing No. 2 Construction Drawings. Pricing for the DBPS public channel (Reimbursable Public facility) is included in

the report after the on-site cost opinion. Using the prior approved and constructed MVE, Inc. Design Drawings (west of this site), the same 20' base with 3:1 side slope channel will be built connecting the existing improvements based upon a 100-year flow depth of 5.06' for the approved MDDP flow rate of  $Q_{100} = 1076$  cfs (using a 30' base instead of 20'). These public rip-rap channel improvements are identified as reimbursable facilities per the Drainage Basin Planning Study and will be used to off-set proposed drainage fees. In no location along this proposed public channel is the freeboard less than 2'. The proposed public channel will be maintained by El Paso County within the existing public drainage easement corridor until acceptance of the public improvements. Per the DBPS the existing downstream public box culvert under Constitution is "to remain". The existing public dual 6' x 12' box culvert was built prior to the 1989 DBPS. Using the approved MDDP flows of  $Q_{100} = 1076$  cfs, a headwater depth calculation is included in the appendix ( $D = 6.9'$ ) which is easily contained within the existing conditions headwall and grading associated with the inlet control condition.

## HYDROLOGIC CALCULATIONS

Hydrologic calculations were performed using the City of Colorado Springs/El Paso County Drainage Criteria Manual, as revised in November 1991 and 1994 with County adopted Chapter 6 and Section 3.2.1 of Chapter 13 of the City of Colorado Springs/El Paso County Drainage Criteria Manual as revised in May 2014. Individual on-site developed basin design used for inlet sizing and storm system routing was calculated using the Rational Method. Full-Spectrum detention pond modeling developed using UD-Detention spreadsheet ver. 3.07, Urban Drainage and Flood Control District.

The City of Colorado Springs/El Paso County DCM requires the Four Step Process for receiving water protection that focuses on reducing runoff volumes, treating the water quality capture volume (WQCV), stabilizing drainage ways, and implementing long-term source controls. The Four Step Process pertains to management of smaller, frequently occurring storm events, as opposed to larger storms for which drainage and flood control infrastructure are sized. Implementation of these four steps helps to achieve storm water permit requirements.

This site adheres to this **Four Step Process** as follows:



1. **Employ Runoff Reduction Practices:** Proposed impervious areas (roof tops, patios) will sheet flow across landscaped yards and through open space areas to slow runoff and increase time of concentration prior to being conveyed to the proposed public streets. This will minimize directly connected impervious areas within the project site.
2. **Stabilize Drainageways:** After developed flows utilize the runoff reduction practices through the yards, these flows will travel via curb and gutter within the public streets and eventually public storm systems. These collected flows are then routed directly to the full-spectrum detention facility on-site and ultimately released into a proposed stabilized drainage channel.
3. **Provide Water Quality Capture Volume (WQCV):** Runoff from this development will be treated through capture and slow release of the WQCV in the proposed full-spectrum permanent Extended Detention Basin (Pond 1) designed per current El Paso County drainage criteria.
4. **Consider need for Industrial and Commercial BMPs:** No industrial or commercial uses are proposed within this development. However, a site-specific storm water quality and erosion control plan and narrative has been submitted along with the grading and erosion control plan. Details such as site-specific source control construction BMP's as well as permanent BMP's were detailed in this plan and narrative to protect receiving waters. BMP's will be constructed and maintained as the development has been graded and erosion control methods employed.

## **FLOODPLAIN STATEMENT**

No portion of this site is located within a FEMA floodplain as determined by the Flood Insurance Rate Maps (F.I.R.M.) Map Number 08041C0752G and 756G, with effective dates of December 7, 2018 (See Appendix).

## **EROSION CONTROL PLAN**

The Drainage Criteria Manual specifies an Erosion Control Plan and associated cost estimate be submitted with the Final Drainage Report. We respectfully request that the Erosion Control Plan and cost estimate be submitted in conjunction with the Overlot Grading Plan and construction assurances



posted prior to obtaining a grading permit. Early grading is not being requested with these applications.

**Midtown Collection at Hannah Ridge Filing No. 3 Drainage Improvement Costs (Non-Reimbursable)**

| ITEM               | DESCRIPTION               | QUANTITY | UNIT COST   | COST                        |
|--------------------|---------------------------|----------|-------------|-----------------------------|
| 1.                 | 2'x2' Type C Grated Inlet | 1 EACH   | \$3,791/EA  | \$ 3,791.00                 |
| 2.                 | 10' Type R Inlet          | 2 EACH   | \$5,950/EA  | \$ 11,900.00                |
| 3.                 | 12" PVC Storm Drain       | 125 LF   | \$60/LF     | \$ 7,500.00                 |
| 4.                 | 18" RCP Storm Drain       | 30 LF    | \$69/LF     | \$ 2,070.00                 |
| 5.                 | 24" RCP Storm Drain       | 215 LF   | \$84/LF     | \$ 18,060.00                |
| 6.                 | 48" RCP Storm Drain       | 60 LF    | \$122/LF    | \$ 7,320.00                 |
| 7.                 | Type I MH                 | 1 EACH   | \$8,592/EA  | \$ 8,592.00                 |
| 8.                 | Type II MH                | 2 EACH   | \$4,575/EA  | \$ 9,150.00                 |
| 9.                 | Pond FSD                  | 1 EACH   | \$83,000/EA | \$ 83,000.00                |
| SUB-TOTAL          |                           |          |             | \$ 151,383.00               |
| 10% ENGINEERING    |                           |          |             | \$ 15,138.30                |
| 5% CONTINGENCIES   |                           |          |             | <u>\$ 7,569.15</u>          |
| <b>GRAND-TOTAL</b> |                           |          |             | <b><u>\$ 174,090.45</u></b> |

**Midtown Collection at Hannah Ridge Filing No. 3 Drainage Improvement Costs (Reimbursable)**

| ITEM               | DESCRIPTION  | QUANTITY | UNIT COST | COST                        |
|--------------------|--------------|----------|-----------|-----------------------------|
| 1.                 | Channel Imps | 450 LF   | \$234/LF* | \$ 105,300.00               |
| SUB-TOTAL          |              |          |           | \$ 105,300.00               |
| 10% ENGINEERING    |              |          |           | \$ 10,530.00                |
| 5% CONTINGENCIES   |              |          |           | <u>\$ 5,265.00</u>          |
| <b>GRAND-TOTAL</b> |              |          |           | <b><u>\$ 121,095.00</u></b> |

\*Per Drainage Basin Planning Study excerpt attached. Unit cost not adjusted for inflation. After Construction Drawing design approval and construction. Reimbursable costs will be verified and an application made to the county and the Drainage Boards to perfect any available credit.

Classic Consulting Engineers & Surveyors cannot and does not guarantee that the construction cost will not vary from these opinions of probable construction costs. These opinions represent our best judgment as design professionals familiar with the construction industry and this development in particular.



## **DRAINAGE & BRIDGE FEES**

This site lies within the Sand Creek Drainage Basin. The fees are calculated using the following impervious acreage method approved by El Paso County. Filing No. 3 is a re-plat of previously platted Tract CC within Filing 1. However, Tract CC was designated as future development and no fees were paid at time of original platting. Thus, the percent imperviousness for each Filing is calculated below based on the following acreage:

Filing 3: 7.44 ac.

The total development area is broken into different residential uses:

PUD zone (1/8 acre or less SF lots – 65% Impervious)

PUD zone Open space/drainage tracts (Greenbelts – 2% Impervious).

The following calculations are based on the 2021 drainage/bridge fees for the Sand Creek Basin:

### **FILING 3:**

#### **2158 SF avg. lots (1/8 acre or less)**

(Per El Paso County Percent Impervious Chart for 1/8 acre or less SF lots: 65%)

7.44 Ac. x 65% = **4.84 Impervious Ac.**

#### **Open Space Tracts**

(Per El Paso County Percent Impervious Chart for greenbelts: 2%)

2.60 Ac. x 2% = **0.05 Impervious Ac.**

**Total Impervious Acreage: 4.89 Imp. Ac.**

### **FILING 3 FEE TOTALS:**

#### **Bridge Fees**

\$ 989.00 x 4.89 Impervious Ac. = \$ 4,836.21

#### **Drainage Fees**

\$ 21,134.00 x 4.89 Impervious Ac. = \$ 103,345.26



These Drainage Fees will be off-set by the public channel improvements.

Fees will be recalculated based upon fees at time of Final Plat submittal. Based upon the required drainage fees being less than the reimbursable drainage channel costs (not adjusted for inflation), no drainage fees will be required with ultimate Final Plat recordation, and only payment of bridge fees will be requested. The appendix of this report includes a summary of all recent plat recordings (everything in the community in now recorded, except this filing) and the offsets used. Reimbursable public facility costs exceed drainage fee obligations. As final costs are tabulated, the credits will be “perfected” per an application to the drainage board.

## **SUMMARY**

This proposed development remains consistent with the previously approved MDDP and Final Drainage Report for Hannah Ridge at Feathergrass Filing No. 1. The existing storm facilities continue to adequately handle both the 5-yr. and 100-yr. developed flows. The proposed detention facility meets current criteria and provides full spectrum design. The proposed development will not adversely impact surrounding developments.

A future Final Plat application will include Construction Drawings and amendment to this report to provide further Final Design details associated with the more detailed design.

PREPARED BY:  
**Classic Consulting**



Kyle R. Campbell, P.E.  
Division Manager

db/111635/REPORTS/fdr



## REFERENCES

1. City of Colorado Springs/County of El Paso Drainage Criteria Manual dated October 1991.\*
2. "Sand Creek Drainage Basin Planning Study," Kiowa Engineering Corp, dated March 1996.
3. "Master Development Drainage Plan for Hannah Ridge", prepared by MVE, Inc. November 2007
4. "Final Drainage Report for Hannah Ridge at Feathergrass Subdivision Filing No. 1", by MVE, Inc. January 2014.
5. Drainage Criteria Manual (Volume 3) latest revision April 2008, Urban Drainage and Flood Criteria District.
6. "Final Drainage Report for Hannah Ridge at Feathergrass Filing No. 3", by MVE, Inc. October 2017.
7. "Final Drainage Report for Hannah Ridge at Feathergrass Filing No. 4", by MVE, Inc. October 2017.
8. El Paso County Engineering Criteria Manual, Resolution No. 20-222, June 23, 2020 (Supp. No.2).

\*EPC Board Resolution NO. 15-042 (El Paso County adoption of Chapter 6 and Section 3.2.1 Chapter 13 of the City of Colorado Springs Drainage Criteria manual dated May 2014, hydrology and full-spectrum detention)

## APPENDIX



## VICINITY MAP

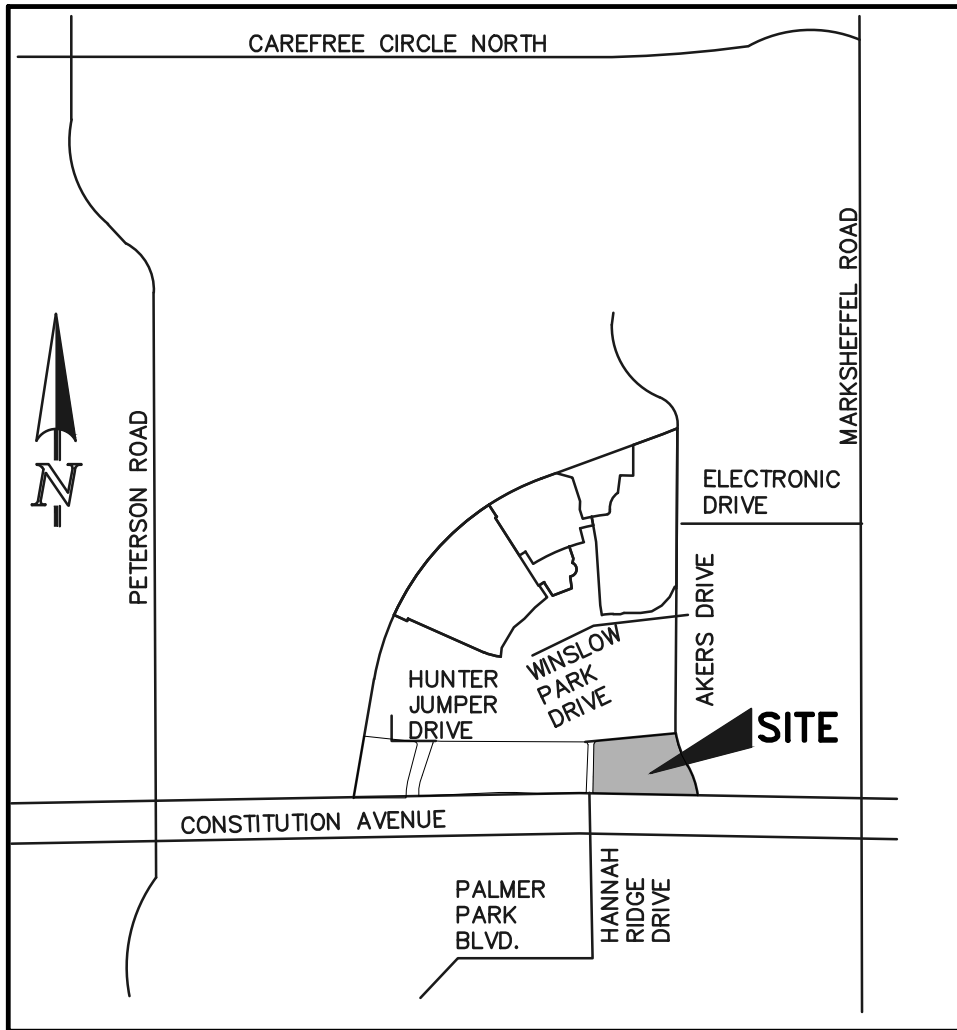

VICINITY MAP

N.T.S.





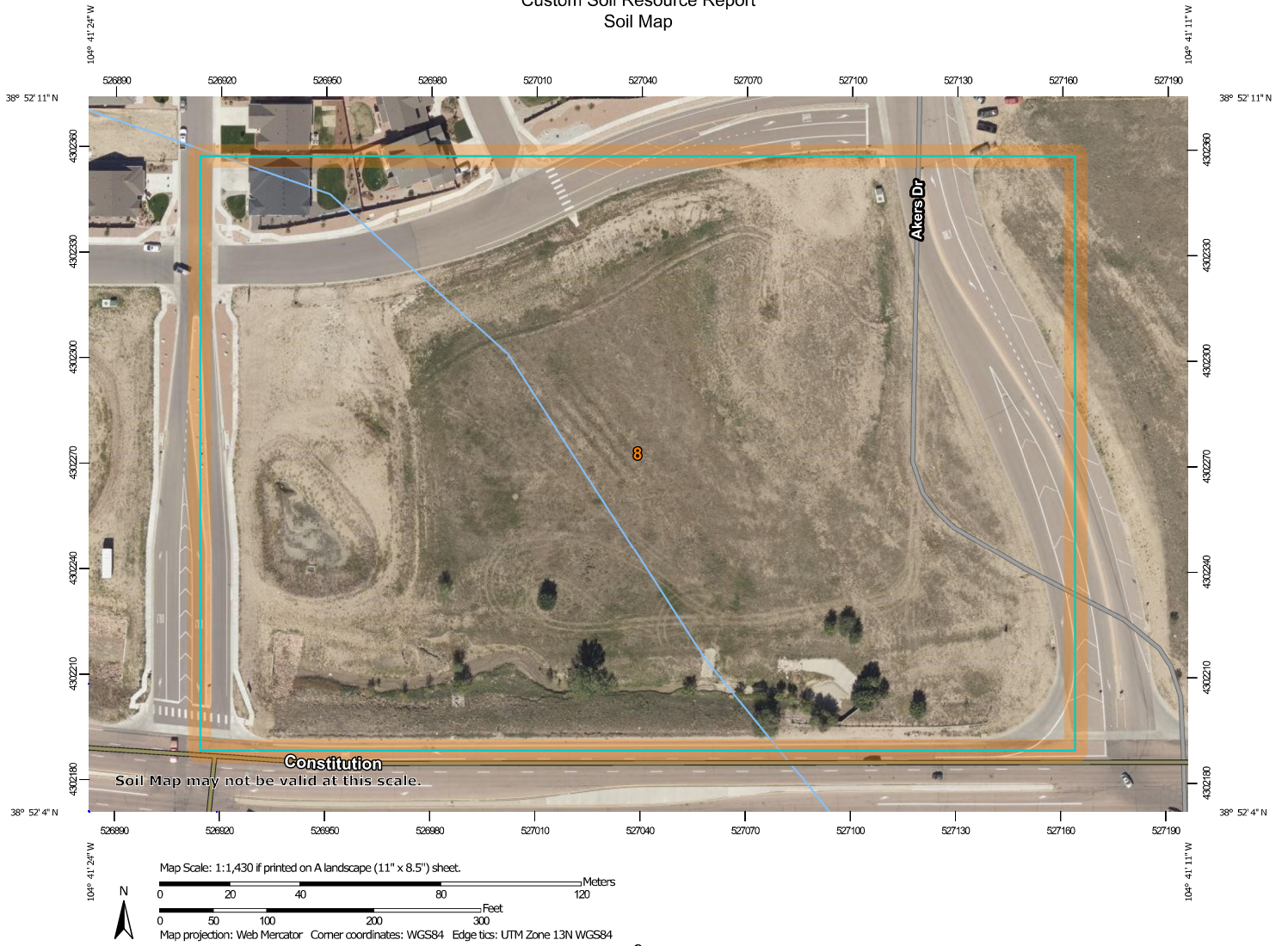































**SOILS MAP (S.C.S SURVEY)**

Custom Soil Resource Report  
Soil Map



## Custom Soil Resource Report

### MAP LEGEND

|   |                        |   |  |
|---|------------------------|---|--|
| <b>Area of Interest (AOI)</b>   |                        |  Spoil Area            |  |
|    | Area of Interest (AOI) |  Stony Spot            |  |
| <b>Soils</b>  |                        |  Very Stony Spot       |  |
|    | Soil Map Unit Polygons |  Wet Spot              |  |
|    | Soil Map Unit Lines    |  Other                 |  |
|    | Soil Map Unit Points   |  Special Line Features |  |
| <b>Special Point Features</b>   |                        | <b>Water Features</b>   |  |
|    | Blowout                |  Streams and Canals    |  |
|    | Borrow Pit             | <b>Transportation</b>   |  |
|    | Clay Spot              |  Rails                 |  |
|    | Closed Depression      |  Interstate Highways   |  |
|    | Gravel Pit             |  US Routes            |  |
|  | Gravelly Spot          |  Major Roads         |  |
|  | Landfill               |  Local Roads         |  |
|  | Lava Flow              | <b>Background</b>   |  |
|  | Marsh or swamp         |  Aerial Photography  |  |
|  | Mine or Quarry         |   |  |
|  | Miscellaneous Water    |   |  |
|  | Perennial Water        |   |  |
|  | Rock Outcrop           |   |  |
|  | Saline Spot            |   |  |
|  | Sandy Spot             |   |  |
|  | Severely Eroded Spot   |   |  |
|  | Sinkhole               |   |  |
|  | Slide or Slip          |   |  |
|  | Sodic Spot             |   |  |

### MAP INFORMATION

The soil surveys that comprise your AOI were mapped at 1:24,000.

Warning: Soil Map may not be valid at this scale.

Enlargement of maps beyond the scale of mapping can cause misunderstanding of the detail of mapping and accuracy of soil line placement. The maps do not show the small areas of contrasting soils that could have been shown at a more detailed scale.

Please rely on the bar scale on each map sheet for map measurements.

Source of Map: Natural Resources Conservation Service  
 Web Soil Survey URL:  
 Coordinate System: Web Mercator (EPSG:3857)

Maps from the Web Soil Survey are based on the Web Mercator projection, which preserves direction and shape but distorts distance and area. A projection that preserves area, such as the Albers equal-area conic projection, should be used if more accurate calculations of distance or area are required.

This product is generated from the USDA-NRCS certified data as of the version date(s) listed below.

Soil Survey Area: El Paso County Area, Colorado  
 Survey Area Data: Version 18, Jun 5, 2020

Soil map units are labeled (as space allows) for map scales 1:50,000 or larger.

Date(s) aerial images were photographed: Aug 19, 2018—Sep 23, 2018

The orthophoto or other base map on which the soil lines were compiled and digitized probably differs from the background imagery displayed on these maps. As a result, some minor shifting of map unit boundaries may be evident.

## Map Unit Legend

| Map Unit Symbol                    | Map Unit Name                               | Acres in AOI | Percent of AOI |
|------------------------------------|---|--------------|----------------|
| 8                                  | Blakeland loamy sand, 1 to 9 percent slopes | 10.5         | 100.0%         |
| <b>Totals for Area of Interest</b> |   | <b>10.5</b>  | <b>100.0%</b>  |

## Map Unit Descriptions

The map units delineated on the detailed soil maps in a soil survey represent the soils or miscellaneous areas in the survey area. The map unit descriptions, along with the maps, can be used to determine the composition and properties of a unit.

A map unit delineation on a soil map represents an area dominated by one or more major kinds of soil or miscellaneous areas. A map unit is identified and named according to the taxonomic classification of the dominant soils. Within a taxonomic class there are precisely defined limits for the properties of the soils. On the landscape, however, the soils are natural phenomena, and they have the characteristic variability of all natural phenomena. Thus, the range of some observed properties may extend beyond the limits defined for a taxonomic class. Areas of soils of a single taxonomic class rarely, if ever, can be mapped without including areas of other taxonomic classes. Consequently, every map unit is made up of the soils or miscellaneous areas for which it is named and some minor components that belong to taxonomic classes other than those of the major soils.

Most minor soils have properties similar to those of the dominant soil or soils in the map unit, and thus they do not affect use and management. These are called noncontrasting, or similar, components. They may or may not be mentioned in a particular map unit description. Other minor components, however, have properties and behavioral characteristics divergent enough to affect use or to require different management. These are called contrasting, or dissimilar, components. They generally are in small areas and could not be mapped separately because of the scale used. Some small areas of strongly contrasting soils or miscellaneous areas are identified by a special symbol on the maps. If included in the database for a given area, the contrasting minor components are identified in the map unit descriptions along with some characteristics of each. A few areas of minor components may not have been observed, and consequently they are not mentioned in the descriptions, especially where the pattern was so complex that it was impractical to make enough observations to identify all the soils and miscellaneous areas on the landscape.

The presence of minor components in a map unit in no way diminishes the usefulness or accuracy of the data. The objective of mapping is not to delineate pure taxonomic classes but rather to separate the landscape into landforms or landform segments that have similar use and management requirements. The delineation of such segments on the map provides sufficient information for the development of resource plans. If intensive use of small areas is planned, however, onsite investigation is needed to define and locate the soils and miscellaneous areas.

## Custom Soil Resource Report

An identifying symbol precedes the map unit name in the map unit descriptions. Each description includes general facts about the unit and gives important soil properties and qualities.

Soils that have profiles that are almost alike make up a *soil series*. Except for differences in texture of the surface layer, all the soils of a series have major horizons that are similar in composition, thickness, and arrangement.

Soils of one series can differ in texture of the surface layer, slope, stoniness, salinity, degree of erosion, and other characteristics that affect their use. On the basis of such differences, a soil series is divided into *soil phases*. Most of the areas shown on the detailed soil maps are phases of soil series. The name of a soil phase commonly indicates a feature that affects use or management. For example, Alpha silt loam, 0 to 2 percent slopes, is a phase of the Alpha series.

Some map units are made up of two or more major soils or miscellaneous areas. These map units are complexes, associations, or undifferentiated groups.

A *complex* consists of two or more soils or miscellaneous areas in such an intricate pattern or in such small areas that they cannot be shown separately on the maps. The pattern and proportion of the soils or miscellaneous areas are somewhat similar in all areas. Alpha-Beta complex, 0 to 6 percent slopes, is an example.

An *association* is made up of two or more geographically associated soils or miscellaneous areas that are shown as one unit on the maps. Because of present or anticipated uses of the map units in the survey area, it was not considered practical or necessary to map the soils or miscellaneous areas separately. The pattern and relative proportion of the soils or miscellaneous areas are somewhat similar. Alpha-Beta association, 0 to 2 percent slopes, is an example.

An *undifferentiated group* is made up of two or more soils or miscellaneous areas that could be mapped individually but are mapped as one unit because similar interpretations can be made for use and management. The pattern and proportion of the soils or miscellaneous areas in a mapped area are not uniform. An area can be made up of only one of the major soils or miscellaneous areas, or it can be made up of all of them. Alpha and Beta soils, 0 to 2 percent slopes, is an example.

Some surveys include *miscellaneous areas*. Such areas have little or no soil material and support little or no vegetation. Rock outcrop is an example.

## El Paso County Area, Colorado

### 8—Blakeland loamy sand, 1 to 9 percent slopes

#### Map Unit Setting

*National map unit symbol:* 369v  
*Elevation:* 4,600 to 5,800 feet  
*Mean annual precipitation:* 14 to 16 inches  
*Mean annual air temperature:* 46 to 48 degrees F  
*Frost-free period:* 125 to 145 days  
*Farmland classification:* Not prime farmland

#### Map Unit Composition

*Blakeland and similar soils:* 98 percent  
*Minor components:* 2 percent  
*Estimates are based on observations, descriptions, and transects of the mapunit.*

#### Description of Blakeland

##### Setting

*Landform:* Hills, flats  
*Landform position (three-dimensional):* Side slope, talf  
*Down-slope shape:* Linear  
*Across-slope shape:* Linear  
*Parent material:* Alluvium derived from sedimentary rock and/or eolian deposits derived from sedimentary rock

##### Typical profile

*A - 0 to 11 inches:* loamy sand  
*AC - 11 to 27 inches:* loamy sand  
*C - 27 to 60 inches:* sand

##### Properties and qualities

*Slope:* 1 to 9 percent  
*Depth to restrictive feature:* More than 80 inches  
*Natural drainage class:* Somewhat excessively drained  
*Runoff class:* Low  
*Capacity of the most limiting layer to transmit water (Ksat):* High to very high (5.95 to 19.98 in/hr)  
*Depth to water table:* More than 80 inches  
*Frequency of flooding:* None  
*Frequency of ponding:* None  
*Calcium carbonate, maximum in profile:* 5 percent  
*Available water storage in profile:* Low (about 4.5 inches)

##### Interpretive groups

*Land capability classification (irrigated):* 3e  
*Land capability classification (nonirrigated):* 6e  
*Hydrologic Soil Group:* A  
*Ecological site:* Sandy Foothill (R049XB210CO)  
*Hydric soil rating:* No

#### Minor Components

##### Pleasant

*Percent of map unit:* 1 percent



## Custom Soil Resource Report

*Landform:* Depressions

*Hydric soil rating:* Yes

### **Other soils**

*Percent of map unit:* 1 percent

*Hydric soil rating:* No

**F.E.M.A. MAP**

# National Flood Hazard Layer FIRMette



104°41'36"W 38°52'22"N



## Legend

SEE FIS REPORT FOR DETAILED LEGEND AND INDEX MAP FOR FIRM PANEL LAYOUT

|                            |  |  |
|----------------------------|--|--|
| SPECIAL FLOOD HAZARD AREAS |  | Without Base Flood Elevation (BFE)<br>Zone A, V, A99 |
|                            |  | With BFE or Depth Zone AE, AO, AH, VE, AR            |
|                            |  | Regulatory Floodway                                  |

|                             |  |   |
|-----------------------------|--|---|
| OTHER AREAS OF FLOOD HAZARD |  | 0.2% Annual Chance Flood Hazard, Areas of 1% annual chance flood with average depth less than one foot or with drainage areas of less than one square mile Zone X |
|                             |  | Future Conditions 1% Annual Chance Flood Hazard Zone X  |
|                             |  | Area with Reduced Flood Risk due to Levee. See Notes, Zone X  |
|                             |  | Area with Flood Risk due to Levee Zone D  |

|             |  |   |
|-------------|--|---|
| OTHER AREAS |  | NO SCREEN Area of Minimal Flood Hazard Zone X |
|             |  | Effective LOMRs                               |
|             |  | Area of Undetermined Flood Hazard Zone D      |

|                    |  |                                  |
|--------------------|--|----------------------------------|
| GENERAL STRUCTURES |  | Channel, Culvert, or Storm Sewer |
|                    |  | Levee, Dike, or Floodwall        |

|                |  |   |
|----------------|--|---|
| OTHER FEATURES |  | 20.2 Cross Sections with 1% Annual Chance Water Surface Elevation |
|                |  | 17.5 Coastal Transect   |
|                |  | Base Flood Elevation Line (BFE)                                   |
|                |  | Limit of Study  |
|                |  | Jurisdiction Boundary   |
|                |  | Coastal Transect Baseline   |
|                |  | Profile Baseline  |
|                |  | Hydrographic Feature  |

|            |  |                           |
|------------|--|---------------------------|
| MAP PANELS |  | Digital Data Available    |
|            |  | No Digital Data Available |
|            |  | Unmapped                  |

The pin displayed on the map is an approximate point selected by the user and does not represent an authoritative property location.

This map complies with FEMA's standards for the use of digital flood maps if it is not void as described below. The basemap shown complies with FEMA's basemap accuracy standards

The flood hazard information is derived directly from the authoritative NFHL web services provided by FEMA. This map was exported on 7/3/2020 at 6:39 PM and does not reflect changes or amendments subsequent to this date and time. The NFHL and effective information may change or become superseded by new data over time.

This map image is void if the one or more of the following map elements do not appear: basemap imagery, flood zone labels, legend, scale bar, map creation date, community identifiers, FIRM panel number, and FIRM effective date. Map images for unmapped and unmodernized areas cannot be used for regulatory purposes.



**REFERENCE MATERIAL FROM ADJACENT STUDIES  
EXISTING CONDITIONS DRAINAGE MAP  
AND CALCULATIONS**

**LEGEND**

- EXISTING INDEX CONTOUR
- EXISTING STORM DRAIN CURB INLET
- EXISTING STORM DRAIN LINE
- EXISTING PROPERTY LINE
- EXISTING ROAD
- DRAINAGE BASIN BOUNDARY
- DRAINAGE BASIN DESIGNATION
- DRAINAGE BASIN AREA
- FLOW DIRECTION AND QUANTITIES
- FLOW DIRECTION
- DESIGN POINT

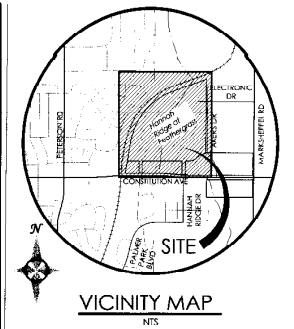
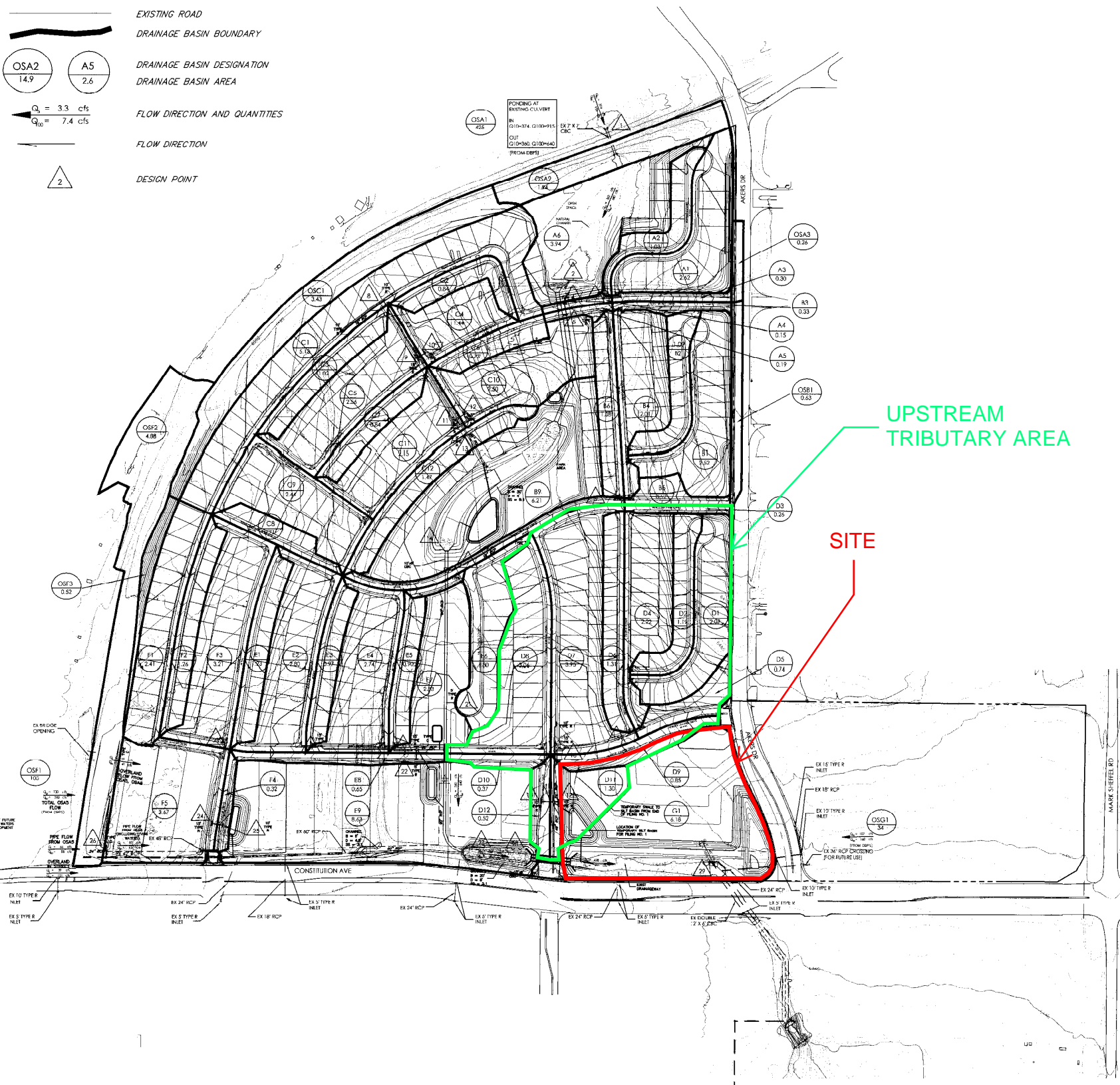

**BENCHMARK**  
 THE BENCHMARK FOR THESE PLANS IS THE TOP OF #4 REBAR, PANEL POINT NO. 1, LOCATED ON THE SOUTH EDGE OF CONSTITUTION AVE AND THE WEST EDGE OF THE ROCK ISLAND TRAIL, 335 FEET WEST OF THE CENTERLINE OF SHAWNEE DR. ELEVATION = 6486.63. (EPIC DATUM ELEVATION = 6485.29).

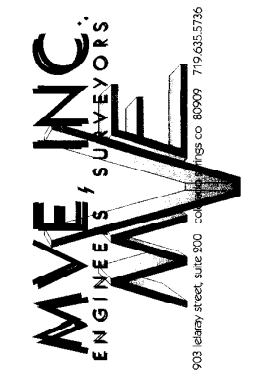
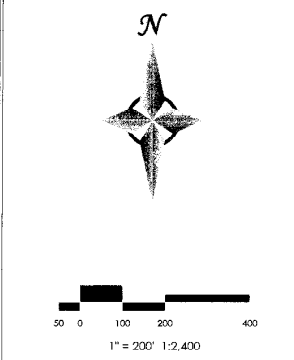

| DEVELOPED SUMMARY RUNOFF TARIFF |  |                        |                         |                            |                                      |
|---------------------------------|--|------------------------|-------------------------|----------------------------|--------------------------------------|
| BASIN or DESIGN POINT           | CONTRIBUTING BASINS  | CONTRIBUTING AREA (AC) | 5-YR (Q5) RUNOFF (CFS)* | 100 YR (Q100) RUNOFF (CFS) | DESCRIPTION                          |
| OSA1 (IN)                       |  | 425                    | 374 *                   | 915 (IN)                   |                                      |
| 1 [OUT]                         | OSA1   | 425                    | 360 *                   | 640 [OUT]                  | EX 7x7 CBC                           |
| 2                               | OSA1, OSA2, A6   | 430.8                  | 360 *                   | 640 *                      | 12'Wx6'H CBC                         |
| 3                               | A1,A2,OSA3,A3  | 4.2                    | 9.4                     | 18.8                       | CROSS PAN                            |
| 4                               | A1,A2,OSA3,A3,A4   | 4.4                    | 9.7                     | 19.2                       | 10' TYPE R INLET (SUMP)              |
| 5                               | A5   | 0.2                    | 0.7                     | 1.3                        | 5' TYPE R INLET (SUMP)               |
| 6                               | OSA1,B1,B2,B3,B4,B5,B6   | 8.2                    | 19.5                    | 38.5                       | CROSS PAN                            |
| 7                               | OSA1,B1,B2,B3,B4,B5,B6,B7                                      | 8.9                    | 20.4                    | 40.1                       | 15' TYPE R (SUMP), 15' TYPE R INLETS |
| 8                               | OSA1,C1  | 8.6                    | 15.0                    | 31.1                       | 10' TYPE R (SUMP), 10' TYPE R INLETS |
| 9                               | C3,C5  | 3.6                    | 8.9                     | 17.8                       | 15' TYPE R INLET (SUMP)              |
| 10                              | C2,C4  | 2.3                    | 5.5                     | 10.9                       | 10' TYPE R INLET (SUMP)              |
| 11                              | C7,C8,C9,C11   | 6.1                    | 13.4                    | 26.6                       | 15' TYPE R INLET (SUMP)              |
| 12                              | C6,C10   | 3.2                    | 6.6                     | 14.1                       | 10' TYPE R INLET (SUMP)              |
| 13                              | C12  | 1.5                    | 3.7                     | 7.4                        | 5' TYPE R INLET (SUMP)               |
| 14                              | OSA1-A6,OSA1-B9, OSC1-C12                                      | 476                    | 360 *                   | 640 *                      | 10'Wx6'H CBC & 90' RCP               |
| 15                              | D1,D2,D3,D4,D5,D6  | 7.8                    | 19.2                    | 38.0                       | CROSS PAN                            |
| 16                              | D1,D2,D3,D4,D5,D6,D7   | 11.7                   | 26.6                    | 52.8                       | 10' TYPE R & 15' TYPE R INLETS       |
| 17                              | D1-D7,D9,D11   | 13.9                   | 29.6                    | 59.0                       | 15' TYPE R INLET (SUMP)              |
| 18                              | D8,D10,D12   | 4.0                    | 8.7                     | 17.1                       | 10' TYPE R INLET (SUMP)              |
| 19                              | E1,E2,E3   | 5.0                    | 11.9                    | 23.7                       | 15' TYPE R INLET                     |
| 20                              | E1,E2,E3,E4,E5,E7  | 11.0                   | 23.4                    | 48.4                       | 15' TYPE R (SUMP), TYPE C INLETS     |
| 21                              | E6   | 1.0                    | 4.5                     | 9.0                        | 5' TYPE R INLET (SUMP)               |
| 22                              | E8   | 0.7                    | 1.8                     | 3.6                        | 5' TYPE R INLET (SUMP)               |
| 23                              | OSF1,F1,F2,F3  | 7.4                    | 16.2                    | 32.5                       | CROSS PAN                            |
| 24                              | OSF1,F1,F2,F3,F5   | 11.0                   | 23.4                    | 48.4                       | 15' TYPE R (SUMP), TYPE C INLETS     |
| 25                              | F4   | 0.3                    | 0.9                     | 1.9                        | 5' TYPE R INLET (SUMP)               |
| 26                              | OSF2   | 4.9                    | 4.2                     | 9.6                        | TYPE D INLET (SUMP)                  |
| 27                              | OSA1-A6,OSA1-B9, OSC1-C12, E1-E9, OSF1-OSF3, F1-F5             | 619                    | 428 *                   | 991 *                      | OPEN CHANNEL                         |
| 28                              | OSA1-A6,OSA1-B9, OSC1-C12, E1-E9, OSF1-OSF3, F1-F5, D1-D12     | 647                    | 428 *                   | 991 *                      | DBL 10'Wx6'H CBC                     |
| 29                              | OSA1-A6,OSA1-B9, OSC1-C12, E1-E9, OSF1-OSF3, F1-F5, D1-D12, G1 | 685                    | 457 *                   | 1076 *                     | EXISTING DBL 12'Wx6'H CBC            |

\* NOTE: MAIN CHANNEL MINOR STORM FLOW RATES ARE 10-YEAR IN ACCORDANCE WITH DRAINAGE BASIN PLANNING STUDY

Existing Conditions Drainage Map

DESIGNED BY DRG August 21, 2013  
 DRAWN BY DRG August 21, 2013  
 CHECKED BY  
 AS-BUILTS BY  
 CHECKED BY

Hannah Ridge at Feathergrass

DEVELOPED Drainage Map

MVE PROJECT 60970  
 MVE DRAWING 60970110

\* OFF-SITE FLOW SUMMARY  
FROM MVE FILING NO. 1 REPORT

| Basin Label                   | Channel Type or Basin   | Cont. Area A <sub>c</sub> (Ac) | 5 Year Coef. C <sub>s</sub> | 100 yr. Coef. of Curve No. C <sub>100</sub> or CN | Manning Rough. n | Length L (ft) | Elev. Change (ft) | Average Slope S | Channel Flow* Q (cfs) | Flow Depth d (ft) | Flow Area A (ft <sup>2</sup> ) | Flow Velocity v (ft/s) | Time of Cont** T <sub>c</sub> (min) | Total Time T <sub>o</sub> (min) | 5 Year Intensity I <sub>5</sub> (in/hr) | 100 Year Intensity I <sub>100</sub> (in/hr) | 5 Year Discharge Q <sub>5</sub> (cfs) | 100 Year Discharge Q <sub>100</sub> (cfs) |
|-------------------------------|-------------------------|--------------------------------|-----------------------------|---|------------------|---------------|-------------------|-----------------|-----------------------|-------------------|--------------------------------|------------------------|-------------------------------------|---------------------------------|---|---|---------------------------------------|---|
| D1+D2+D3+D4                   | 3                       | 5.7                            | 0.61                        | 0.71  | 0.016            | 0             | 0                 | 0.250           | 31.76                 | 0.33              | 2.39                           | 13.31                  | 0.0                                 | 10.0                            | 4.09                                    | 7.00  | 14.3                                  | 28.3                                      |
| D5                            | 0                       | 0.7                            | 0.57                        | 0.66  | --               | 140           | 6                 | 0.043           | --                    | --                | --                             | --                     | 7.2                                 | --                              | --                                      | --  | --                                    | --  |
| D5                            | 3                       | 0.7                            | 0.57                        | 0.66  | 0.016            | 310           | 13                | 0.040           | --                    | --                | --                             | --                     | 10.0                                | --                              | --                                      | --  | --                                    | --  |
| D1+D2+D3+D4+D5                | D1+D2+D3+D4             | 5.7                            | 0.61                        | 0.71  | --               | --            | --                | --              | 3.87                  | 0.22              | 0.97                           | 3.98                   | 1.3                                 | 8.5                             | 4.36                                    | 7.48  | 1.9                                   | 3.6                                       |
| D1+D2+D3+D4+D5                | 3                       | 6.5                            | 0.60                        | 0.70  | 0.016            | 0             | 0                 | 0.250           | 35.58                 | 0.34              | 2.60                           | 13.69                  | 0.0                                 | 10.0                            | 4.09                                    | 7.00  | 16.0                                  | 31.7                                      |
| D8                            | 0                       | 1.3                            | 0.60                        | 0.70  | --               | 60            | 1                 | 0.013           | --                    | --                | --                             | --                     | 6.6                                 | --                              | --                                      | --  | --                                    | --  |
| D8                            | 3                       | 1.3                            | 0.60                        | 0.70  | 0.016            | 535           | 22                | 0.040           | 7.52                  | 0.27              | 1.60                           | 4.69                   | 1.9                                 | --                              | --                                      | --  | --                                    | --  |
| D6                            | 3                       | 1.3                            | 0.60                        | 0.70  | 0.016            | 210           | 4                 | 0.020           | 7.52                  | 0.31              | 2.07                           | 3.63                   | 1.0                                 | 9.5                             | 4.18                                    | 7.15  | 3.3                                   | 6.6                                       |
| D1+D2+D3+D4+D5+D6             | D1+D2+D3+D4+D5          | 6.5                            | 0.60                        | 0.70  | --               | --            | --                | --              | --                    | --                | --                             | --                     | 10.0                                | --                              | --                                      | --  | --                                    | --  |
| D1+D2+D3+D4+D5+D6             | 3                       | 7.8                            | 0.60                        | 0.70  | 0.016            | 35            | 1                 | 0.040           | 42.78                 | 0.51              | 5.94                           | 7.20                   | 0.1                                 | 10.0                            | 4.08                                    | 6.97  | 19.2                                  | 38.0                                      |
| D7                            | 0                       | 4.0                            | 0.60                        | 0.70  | --               | 140           | 2                 | 0.015           | --                    | --                | --                             | --                     | 9.7                                 | --                              | --                                      | --  | --                                    | --  |
| D7                            | 3                       | 4.0                            | 0.60                        | 0.70  | 0.016            | 475           | 19                | 0.040           | 19.58                 | 0.38              | 3.32                           | 5.90                   | 1.3                                 | --                              | --                                      | --  | --                                    | --  |
| D7                            | 3                       | 4.0                            | 0.60                        | 0.70  | 0.016            | 270           | 4                 | 0.015           | 19.58                 | 0.46              | 4.80                           | 4.08                   | 1.1                                 | 12.1                            | 3.77                                    | 6.43  | 8.9                                   | 17.8                                      |
| D1+D2+D3+D4+D5+D6+D7          | D7                      | 4.0                            | 0.60                        | 0.70  | --               | --            | --                | --              | --                    | --                | --                             | --                     | 12.1                                | --                              | --                                      | --  | --                                    | --  |
| D1+D2+D3+D4+D5+D6+D7          | 3                       | 11.7                           | 0.60                        | 0.70  | 0.016            | 0             | 0                 | 0.250           | 58.18                 | 0.41              | 3.76                           | 15.47                  | 0.0                                 | 12.1                            | 3.77                                    | 6.43  | 26.6                                  | 52.8                                      |
| D9                            | 0                       | 0.9                            | 0.50                        | 0.58  | --               | 40            | 1                 | 0.020           | --                    | --                | --                             | --                     | 5.6                                 | --                              | --                                      | --  | --                                    | --  |
| D9                            | 3                       | 0.9                            | 0.50                        | 0.58  | 0.016            | 585           | 20                | 0.034           | 4.28                  | 0.23              | 1.12                           | 3.83                   | 2.5                                 | 8.2                             | 4.42                                    | 7.58  | 1.9                                   | 3.8                                       |
| D1+D2+D3+D4+D5+D6+D9          | D1+D2+D3+D4+D5+D6       | 7.8                            | 0.60                        | 0.70  | --               | --            | --                | --              | --                    | --                | --                             | --                     | 10.0                                | --                              | --                                      | --  | --                                    | --  |
| D1+D2+D3+D4+D5+D6+D9          | 3                       | 8.6                            | 0.59                        | 0.69  | 0.016            | 300           | 11                | 0.036           | 46.67                 | 0.53              | 6.60                           | 7.07                   | 0.7                                 | 10.7                            | 3.97                                    | 6.78  | 20.3                                  | 40.3                                      |
| D1+D2+D3+D4+D5+D6+D7+D9       | D1+D2+D3+D4+D5+D6+D7    | 11.7                           | 0.60                        | 0.70  | --               | --            | --                | --              | --                    | --                | --                             | --                     | 12.1                                | --                              | --                                      | --  | --                                    | --  |
| D1+D2+D3+D4+D5+D6+D7+D9       | 3                       | 12.6                           | 0.59                        | 0.69  | 0.016            | 0             | 0                 | 0.250           | 61.69                 | 0.42              | 3.93                           | 15.69                  | 0.0                                 | 12.1                            | 3.77                                    | 6.43  | 28.2                                  | 56.0                                      |
| D8                            | 0                       | 3.1                            | 0.60                        | 0.70  | --               | 120           | 1                 | 0.010           | --                    | --                | --                             | --                     | 10.2                                | --                              | --                                      | --  | --                                    | --  |
| D8                            | 3                       | 3.1                            | 0.60                        | 0.70  | 0.016            | 450           | 18                | 0.040           | 14.81                 | 0.35              | 2.68                           | 5.53                   | 1.4                                 | --                              | --                                      | --  | --                                    | --  |
| D8                            | 3                       | 3.1                            | 0.60                        | 0.70  | 0.016            | 270           | 4                 | 0.015           | 14.81                 | 0.41              | 3.89                           | 3.81                   | 1.2                                 | 12.8                            | 3.68                                    | 6.28  | 6.8                                   | 13.4                                      |
| D10                           | 0                       | 0.4                            | 0.60                        | 0.70  | --               | 32            | 1                 | 0.020           | --                    | --                | --                             | --                     | 4.2                                 | --                              | --                                      | --  | --                                    | --  |
| D10                           | 3                       | 0.4                            | 0.60                        | 0.70  | 0.016            | 330           | 7                 | 0.020           | 2.33                  | 0.21              | 0.87                           | 2.68                   | 2.1                                 | 6.2                             | 4.85                                    | 8.35  | 1.1                                   | 2.2                                       |
| D8+D10                        | D8                      | 3.1                            | 0.60                        | 0.70  | --               | --            | --                | --              | --                    | --                | --                             | --                     | 12.8                                | --                              | --                                      | --  | --                                    | --  |
| D8+D10                        | 3                       | 3.4                            | 0.60                        | 0.70  | 0.016            | 0             | 0                 | 0.250           | 16.61                 | 0.26              | 1.47                           | 11.33                  | 0.0                                 | 12.8                            | 3.68                                    | 6.28  | 7.6                                   | 15.1                                      |
| D11                           | 0                       | 1.3                            | 0.38                        | 0.47  | --               | 210           | 4                 | 0.019           | --                    | --                | --                             | --                     | 15.9                                | --                              | --                                      | --  | --                                    | --  |
| D11                           | 3                       | 1.3                            | 0.38                        | 0.47  | 0.016            | 95            | 1                 | 0.015           | 3.43                  | 0.25              | 1.30                           | 2.64                   | 0.6                                 | 16.5                            | 3.26                                    | 5.57  | 1.6                                   | 3.4                                       |
| D1+D2+D3+D4+D5+D6+D9+D11      | D1+D2+D3+D4+D5+D6+D9    | 8.6                            | 0.59                        | 0.69  | --               | --            | --                | --              | --                    | --                | --                             | --                     | 10.7                                | --                              | --                                      | --  | --                                    | --  |
| D1+D2+D3+D4+D5+D6+D9+D11      | 3                       | 9.9                            | 0.56                        | 0.66  | 0.016            | 130           | 2                 | 0.015           | 51.42                 | 0.64              | 9.77                           | 5.27                   | 0.4                                 | 11.2                            | 3.90                                    | 6.87  | 21.9                                  | 43.7                                      |
| * D1+D2+D3+D4+D5+D6+D7+D9+D11 | D1+D2+D3+D4+D5+D6+D7+D9 | 12.6                           | 0.59                        | 0.69  | --               | --            | --                | --              | --                    | --                | --                             | --                     | 12.1                                | --                              | --                                      | --  | --                                    | --  |
| D1+D2+D3+D4+D5+D6+D7+D9+D11   | 3                       | 13.9                           | 0.57                        | 0.67  | 0.016            | 140           | 2                 | 0.015           | 65.98                 | 0.71              | 11.89                          | 5.55                   | 0.4                                 | 12.5                            | 3.71                                    | 6.33  | 29.6                                  | 59.0                                      |
| D12                           | 0                       | 0.5                            | 0.65                        | 0.72  | --               | 85            | 3                 | 0.035           | --                    | --                | --                             | --                     | 5.1                                 | --                              | --                                      | --  | --                                    | --  |
| D12                           | 3                       | 0.5                            | 0.65                        | 0.72  | 0.016            | 130           | 2                 | 0.015           | 3.33                  | 0.24              | 1.25                           | 2.67                   | 0.8                                 | 5.9                             | 4.93                                    | 8.50  | 1.7                                   | 3.2                                       |
| D8+D10+D12                    | D8+D10+D12              | 3.4                            | 0.60                        | 0.70  | --               | --            | --                | --              | --                    | --                | --                             | --                     | 12.8                                | --                              | --                                      | --  | --                                    | --  |
| D8+D10+D12                    | 3                       | 4.0                            | 0.81                        | 0.70  | 0.016            | 130           | 2                 | 0.015           | 19.19                 | 0.45              | 4.66                           | 4.12                   | 0.5                                 | 13.3                            | 3.61                                    | 6.16  | 8.7                                   | 17.1                                      |
| E1                            | 0                       | 1.2                            | 0.60                        | 0.70  | --               | 65            | 1                 | 0.015           | --                    | --                | --                             | --                     | 6.5                                 | --                              | --                                      | --  | --                                    | --  |
| E1                            | 3                       | 1.2                            | 0.60                        | 0.70  | 0.016            | 615           | 11                | 0.018           | 7.08                  | 0.31              | 2.08                           | 3.40                   | 3.0                                 | 9.6                             | 4.16                                    | 7.12  | 3.1                                   | 6.1                                       |
| E2                            | 0                       | 2.8                            | 0.60                        | 0.70  | --               | 130           | 3                 | 0.020           | --                    | --                | --                             | --                     | 8.5                                 | --                              | --                                      | --  | --                                    | --  |
| E2                            | 3                       | 2.8                            | 0.60                        | 0.70  | 0.016            | 580           | 11                | 0.020           | 14.63                 | 0.39              | 3.47                           | 4.22                   | 2.3                                 | 10.8                            | 3.96                                    | 6.77  | 6.7                                   | 13.3                                      |
| E1+E2                         | E2                      | 2.8                            | 0.60                        | 0.70  | --               | --            | --                | --              | --                    | --                | --                             | --                     | 10.8                                | --                              | --                                      | --  | --                                    | --  |
| E1+E2                         | 3                       | 4.0                            | 0.60                        | 0.70  | 0.016            | 0             | 0                 | 0.250           | 21.06                 | 0.29              | 1.75                           | 12.02                  | 0.0                                 | 10.8                            | 3.96                                    | 6.77  | 9.6                                   | 19.1                                      |
| E3                            | 0                       | 1.0                            | 0.60                        | 0.70  | --               | 60            | 1                 | 0.015           | --                    | --                | --                             | --                     | 6.3                                 | --                              | --                                      | --  | --                                    | --  |
| E3                            | 3                       | 1.0                            | 0.60                        | 0.70  | 0.016            | 515           | 10                | 0.020           | 5.64                  | 0.28              | 1.68                           | 3.37                   | 2.6                                 | 8.9                             | 4.28                                    | 7.33  | 2.5                                   | 5.0                                       |
| E1+E2+E3                      | E1+E2                   | 4.0                            | 0.60                        | 0.70  | --               | --            | --                | --              | --                    | --                | --                             | --                     | 10.8                                | --                              | --                                      | --  | --                                    | --  |
| E1+E2+E3                      | 3                       | 5.0                            | 0.60                        | 0.70  | 0.016            | 0             | 0                 | 0.250           | 26.13                 | 0.31              | 2.06                           | 12.68                  | 0.0                                 | 10.8                            | 3.96                                    | 6.77  | 11.9                                  | 23.7                                      |
| E4                            | 0                       | 2.7                            | 0.60                        | 0.70  | --               | 125           | 3                 | 0.020           | --                    | --                | --                             | --                     | 8.3                                 | --                              | --                                      | --  | --                                    | --  |
| E4                            | 3                       | 2.7                            | 0.60                        | 0.70  | 0.016            | 500           | 11                | 0.023           | 14.43                 | 0.38              | 3.24                           | 4.45                   | 1.9                                 | 10.2                            | 4.06                                    | 6.93  | 6.7                                   | 13.3                                      |
| E1+E2+E3+E4                   | E1+E2+E3                | 5.0                            | 0.60                        | 0.70  | --               | --            | --                | --              | --                    | --                | --                             | --                     | 10.8                                | --                              | --                                      | --  | --                                    | --  |
| E1+E2+E3+E4                   | 3                       | 7.0                            | 0.60                        | 0.70  | 0.016            | 295           | 8                 | 0.025           | 40.45                 | 0.54              | 6.75                           | 5.99                   | 0.8                                 | 11.6                            | 3.84                                    | 6.56  | 17.8                                  | 35.5                                      |
| E5                            | 0                       | 0.9                            | 0.60                        | 0.70  | --               | 60            | 1                 | 0.015           | --                    | --                | --                             | --                     | 6.3                                 | --                              | --                                      | --  | --                                    | --  |
| E5                            | 3                       | 0.9                            | 0.60                        | 0.70  | 0.016            | 460           | 11                | 0.023           | 5.24                  | 0.27              | 1.50                           | 3.50                   | 2.2                                 | 8.5                             | 4.35                                    | 7.45  | 2.3                                   | 4.7                                       |
| E1+E2+E3+E4+E5                | E1+E2+E3+E4             | 7.7                            | 0.60                        | 0.70  | --               | --            | --                | --              | --                    | --                | --                             | --                     | 11.6                                | --                              | --                                      | --  | --                                    | --  |
| E1+E2+E3+E4+E5                | 3                       | 8.6                            | 0.60                        | 0.70  | 0.016            | 0             | 0                 | 0.250           | 45.16                 | 0.37              | 3.11                           | 14.52                  | 0.0                                 | 11.6                            | 3.84                                    | 6.56  | 18.9                                  | 39.7                                      |
| E6                            | 0                       | 1.8                            | 0.60                        | 0.70  | --               | 105           | 3                 | 0.029           | --                    | --                | --                             | --                     | 6.8                                 | --                              | --                                      | --  | --                                    | --  |
| E6                            | 3                       | 1.8                            | 0.60                        | 0.70  | 0.016            | 575           | 8                 | 0.015           | 10.23                 | 0.36              | 2.96                           | 3.45                   | 2.8                                 | 9.5                             | 4.16                                    | 7.12  | 4.5                                   | 9.0                                       |
| E7                            | 0                       | 2.3                            | 0.43                        | 0.61  | --               | 200           | 4                 | 0.020           | --                    | --                | --                             | --                     | 14.1                                | --                              | --                                      | --  | --                                    | --  |
| E7                            | 3                       | 2.3                            | 0.43                        | 0.61  | 0.016            | 365           | 7                 | 0.019           | 8.58                  | 0.33              | 2.34                           | 3.66                   | 1.7                                 | 15.8                            | 3.33                                    | 5.69  | 3.3                                   | 8.1                                       |
| E4+E5                         | E4                      | 2.7                            | 0.60                        | 0.70  | --               | --            | --                | --              | --                    | --                | --                             | --                     | 10.2                                | --                              | --                                      | --  | --                                    | --  |
| E4+E5                         | 3                       | 3.6                            | 0.60                        | 0.70  | 0.016            | 0             | 0                 | 0.250           | 19.17                 | 0.28              | 1.63                           | 11.74                  | 0.0                                 | 10.2                            | 4.06                                    | 6.93  | 8.9                                   | 17.7                                      |
| E4+E5+E7                      | E4+E5                   | 3.6                            | 0.60                        | 0.70  | --               | --            | --                | --              | --                    | --                | --                             | --                     | 10.2                                | --                              | --                                      | --  | --                                    | --  |
| E4+E5+E7                      | 3                       | 6.0                            | 0.53                        | 0.67  | 0.016            | 100           | 3                 | 0.025           | 29.94                 | 0.49              | 5.42                           | 5.52                   | 0.3                                 | 10.5                            | 4.01                                    | 6.85  | 12.6                                  | 27.2                                      |
| E1+E2+E3+E4+E5+E7             | E1+E2+E3+E4+E5          | 8.6                            | 0.60                        | 0.70  | --               | --            | --                | --              | --                    | --                | --                             | --                     | 11.6                                | --                              | --                                      | --  | --                                    | --  |
| E1+E2+E3+E4+E5+E7             | 3                       | 11.0                           | 0.58                        | 0.68  | 0.016            | 100           | 1                 | 0.010           | 55.85                 | 0.72              | 12.21                          | 4.57                   | 0.4                                 | 12.0                            | 3.79                                    | 6.47  | 23.4                                  | 48.4                                      |

## HANNAH RIDGE AT FEATHER GRASS REIMBURSABLE COST SUMMARY

Job 1116.05 (revised 5-22-20)

| Filing                   | Acreage (AC)   | % Impervious | Drainage Fee         | Drainage Fee Pd.    | Bridge Fee           | Reimbursable Drainage Facility Estimate | Possible 10% Engineering Reimbursable | DBPS Reimbursable Facility Costs From DBPS | DBPS Reimbursable Facility Costs From DBPS w/ Inflation Factor | Inflation Factor | Comment                                  |
|--------------------------|----------------|--------------|----------------------|---------------------|----------------------|---|---------------------------------------|--|--|------------------|--|
| NO. 1                    | 31.22          | 38%          |                      |                     | \$ 51,689.71         | N/A                                     |                                       |  |  | N/A              |  |
| 4/23/2014*               | 9.68           | 38%          | \$ 55,176.00         |                     | \$ 16,714.65         |   |                                       |  |  |                  | SF-13-013                                |
|                          |                |              | \$ 15,000.00         |                     | (\$4,357/ac)         |   |                                       |  |  |                  |  |
| NO. 2                    | 9.27           | 38%          | \$ 52,839.00         | \$ 89,046.43        | \$ 16,006.69         | \$ 159,068.00                           | \$ 15,906.80                          | N/A  | N/A  | N/A              | Facilities installed - DBPS 12A          |
| 10/6/2015                |                |              | \$ 15,000.00         |                     | (\$4,544/ac)         |   |                                       |  |  |                  | SF-15-013                                |
| NO. 3                    | 8.31           | 51%          | \$ 68,953.89         |                     | \$ 20,889.59         | \$ 589,961.00                           | \$ 58,996.10                          | \$462,600.00                               | \$501,921.00   | 1.085 (2017)     | Facilities installed - DBPS 12A          |
|                          |                |              | \$ 16,270.00         |                     | (\$4,929/ac)         |   |                                       |  |  | 1.085            | SF-17-012                                |
| NO. 4                    | 10.12          | 51%          | \$ 83,972.72         |                     | \$ 25,439.55         | N/A                                     |                                       | N/A  | N/A  | N/A              |  |
|                          |                |              | \$ 16,270.00         |                     | \$ 4,929.00          |   |                                       |  |  |                  | SF-17-013                                |
| NO. 5                    | 11.926         | 53%          | \$ 112,554.37        |                     | \$ 35,192.92         | \$ 412,620.00                           | \$ 41,262.00                          | \$427,320.00                               | \$522,612.36   | 1.223 (2019)     | To be installed w/ Fil 5 - DBPS 12       |
|                          | 0.99           | 2%           | \$ 17,751.00         |                     | \$ 5,559.00          | **                                      |                                       |  |  | 1.223            | SF-18-038                                |
| NO. 6                    | 6.25           | 60%          | \$ 67,166.23         |                     | \$ 21,186.46         | N/A                                     |                                       | N/A  | N/A  | N/A              |  |
|                          | 1.69           | 2%           | \$ 17,751.00         |                     | \$ 5,559.00          |   |                                       |  |  |                  | SF-18-039                                |
| NO. 7                    | 13.71          | 60%          | \$ 146,019.73        |                     | \$ 45,728.33         | incl in above filing 5                  |                                       | \$190,470.00                               | \$232,944.81   | 1.223 (2019)     | Facilities installed w/ Fil 7 - DBPS 195 |
|                          |                | ***          | \$ 17,751.00         |                     | \$ 5,559.00          |   |                                       |  |  | 1.223            | SF-18-040                                |
| Midtown Fil 1 (estimate) | 5.4            | 65%          | \$ 67,805.20         |                     | \$ 10,873.40         | N/A                                     |                                       | N/A  | N/A  | N/A              |  |
|                          | 3.72           | 2%           | \$ 18,940.00         |                     | \$ 5,559.00          |   |                                       |  |  |                  | SF-19-007                                |
| Midtown Fil 2 (estimate) | 2.27           | 65%          | \$ 28,410.00         |                     | \$ 30,418.85         | N/A                                     |                                       | N/A  | N/A  | N/A              |  |
|                          | 0.99           | 2%           | \$ 18,940.00         |                     | \$ 5,559.00          |   |                                       |  |  |                  | SF-19-006                                |
| <b>TOTAL</b>             | <b>115.546</b> | <b>45%</b>   | <b>\$ 682,897.14</b> | <b>\$ 89,046.43</b> | <b>\$ 274,140.15</b> | <b>\$ 1,161,649.00</b>                  | <b>\$ 116,164.90</b>                  | <b>\$1,080,390.00</b>                      | <b>\$1,257,478.17</b>  |                  |  |
|                          |                |              |                      |                     | Over-calculated      |   |                                       | \$ 1,080,390.00                            |  |                  |  |

### Entire Community Build-out Summary

|  |                 |
|--|-----------------|
| Total possible Credit per estimates incl |                 |
| engineering                              | \$ 1,277,813.90 |
| Fee Offset                               | \$ 682,897.14   |
| Fees Paid                                | \$ 89,046.43    |
| Possible Credits in EPC                  |                 |
| Sand Creek Basin                         | \$ 683,963.19   |

### To-date Summary with Constructed Facilities and Recorded Plats Only

|   |               |
|---|---------------|
| Total possible Credit per constructed reimbursable improvements |               |
| improvements  | \$ 823,931.90 |
| Fee Offset  | \$ 682,897.14 |
| Fees Paid   | \$ 89,046.43  |
| Offsets available for platting                                  |               |
|   | \$ 230,081.19 |

NOTE:

Total Reimbursable Drainage Factors for Filing No. 1 to 7 = \$2,476,616.00 (per MVE approved reports)

\* Revised per Filing No. 2 Correction

\*\* See Filing 5 Reimbursable Costs

\*\*\* See Fee breakdown based on Imp. Ac.

THIS DRAWING IS A MASTER PLANNING SHEET REPRESENTING PRELIMINARY AND CONCEPTUAL ENGINEERING. IT SHOULD NOT BE USED FOR CONSTRUCTION PURPOSES. THESE PLANS ARE SUBJECT TO CHANGE.

Kiowa Engineering Corporation  
 419 W. Bijou Street  
 Colorado Springs, Colorado  
 80905-1308

SAND CREEK DRAINAGE  
 BASIN PLANNING STUDY  
 PRELIMINARY DESIGN PLANS

|             |  |
|-------------|--|
| Project No. |  |
| Date:       |  |
| Design:     |  |
| Drawn:      |  |
| Check:      |  |
| Revisions:  |  |

EF-21

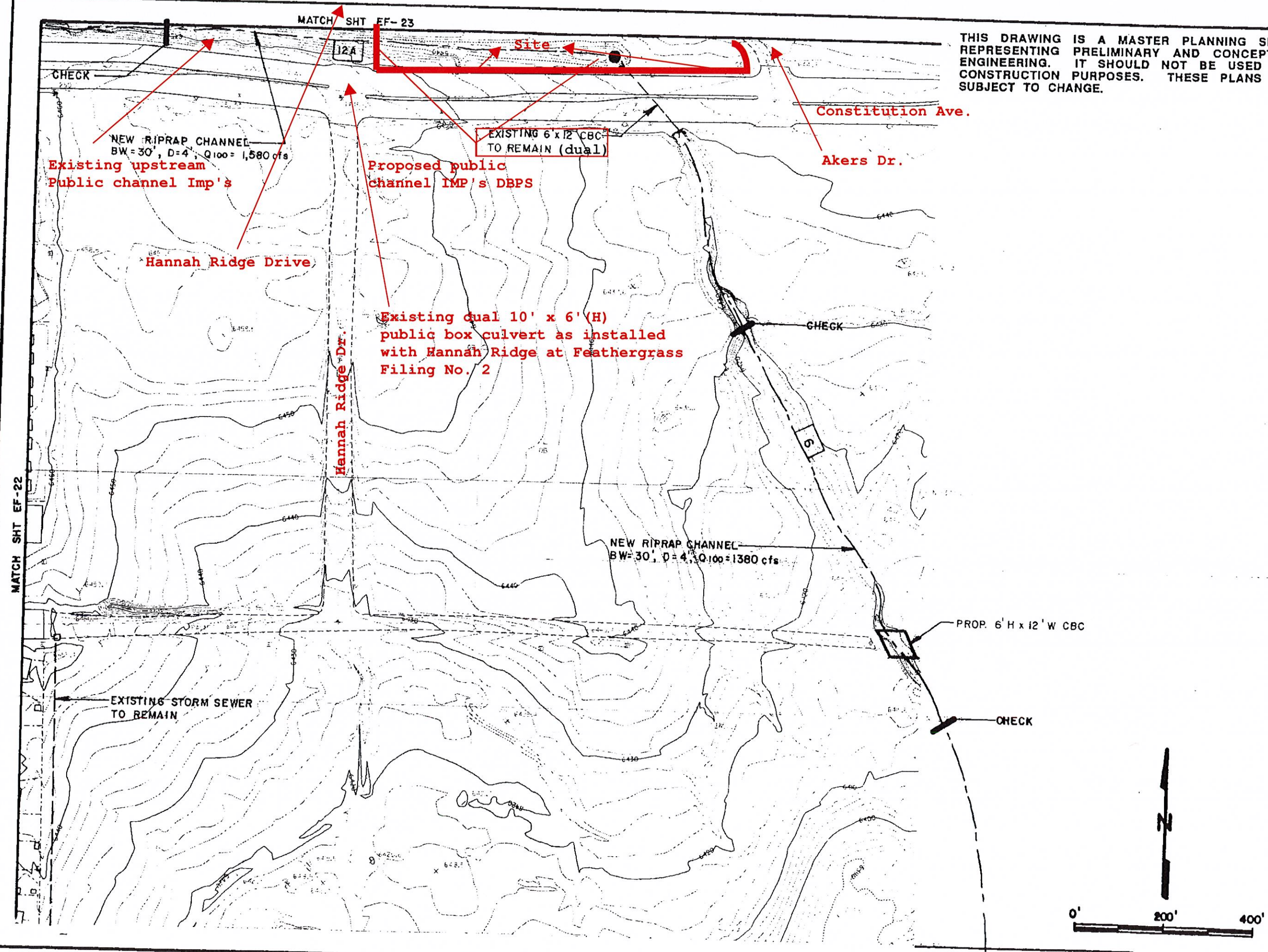



TABLE VIII-3: SAND CREEK DRAINAGE BASIN PLANNING STUDY  
 cont'd TRIBUTARY DRAINAGEWAY CONVEYANCE COST ESTIMATE  
 EAST FORK SAND CREEK TRIBUTARIES

| SEGMENT NUMBER       | REACH NUMBER | IMPROVEMENT TYPE        | IMP. LENGTH (FT) | UNIT COST (\$/LF) | NUMBER OF GRADE CONTROLS | LENGTH OF GRADE CONTROL (FT) | TOTAL REIMBURSABLE COSTS | TOTAL COST  |
|----------------------|--------------|-------------------------|------------------|-------------------|--------------------------|------------------------------|--------------------------|-------------|
| EAST FORK SAND CREEK |              |                         |                  |                   |                          |                              |                          |             |
| 104                  | EF-2         | 100-YR RIPRAP           | 450              | 205               | 7                        | 350                          | \$0                      | \$144,750   |
| 8                    | EF-2         | 100-YR RIPRAP           | 3540             | 120               | 4                        | 120                          | \$442,800                | \$442,800   |
| 8A                   | EF-2         | 100-YR RIPRAP           | 1920             | 234               | 2                        | 70                           | \$459,700                | \$459,780   |
| 6                    | EF-2         | 100-YR RIPRAP           | 5200             | 234               | 4                        | 240                          | \$1,252,800              | \$1,252,800 |
| 112                  | EF-2         | EX. SYSTEM TO REMAIN    | 1150             | 0                 | 0                        | 0                            | \$0                      | \$0         |
| → 12A                | EF-2         | 100-YR RIPRAP           | 1900             | 234               | 2                        | 120                          | \$462,600                | \$462,600   |
| 195                  | EF-2         | 100-YR RIPRAP           | 980              | 189               | 1                        | 35                           | \$190,470                | \$190,470   |
| 12                   | EF-2         | 100-YR RIPRAP           | 1730             | 234               | 3                        | 150                          | \$427,320                | \$427,320   |
| 20                   | EF-2         | 100-YR RIPRAP           | 3650             | 234               | 10                       | 500                          | \$929,100                | \$929,100   |
| 17                   | EF-4         | 100-YR RIPRAP           | 1300             | 205               | 2                        | 100                          | \$281,500                | \$281,500   |
| 124A                 | EF-4         | 100-YR RIPRAP           | 1750             | 234               | 2                        | 80                           | \$421,500                | \$421,500   |
| 198                  | EF-4         | 100-YR RIPRAP           | 3650             | 205               | 4                        | 160                          | \$722,250                | \$772,250   |
| 30                   | EF-4         | 100-YR RIPRAP           | 4500             | 205               | 3                        | 150                          | \$945,000                | \$945,000   |
| 75                   | EF-7         | 100-YR RIPRAP           | 4200             | 234               | 10                       | 700                          | \$1,087,800              | \$1,087,800 |
| 173                  | EF-7         | 100-YR RIPRAP           | 1600             | 234               | 2                        | 120                          | \$392,400                | \$392,400   |
| 72                   | EF-7         | 100-YR RIPRAP           | 4500             | 205               | 8                        | 560                          | \$1,006,500              | \$1,006,500 |
| 57                   | EF-7         | 100-YR RIPRAP           | 3200             | 234               | 3                        | 120                          | \$766,800                | \$766,800   |
| 55                   | EF-6         | 100-YR RIPRAP           | 2800             | 234               | 3                        | 135                          | \$675,450                | \$675,450   |
| 31                   | EF-5         | 100-YR RIPRAP           | 2900             | 205               | 7                        | 210                          | \$626,000                | \$626,000   |
| 144                  | EF-6         | 100-YR RIPRAP           | 2050             | 189               | 3                        | 60                           | \$396,450                | \$396,450   |
| 82                   | EF-8         | SELECTIVE RIPRAP LINING | 5700             | 85                | 5                        | 150                          | \$507,000                | \$507,000   |
| 83                   | EF-8         | SELECTIVE RIPRAP LINING | 5400             | 93                | 6                        | 180                          | \$529,200                | \$529,200   |
| 194A                 | EF-8         | SELECTIVE RIPRAP LINING | 1900             | 93                | 2                        | 60                           | \$185,700                | \$185,700   |
| 88                   | EF-8         | SELECTIVE RIPRAP LINING | 5500             | 57                | 5                        | 150                          | \$336,000                | \$336,000   |
| 85                   | EF-8         | SELECTIVE RIPRAP LINING | 5900             | 93                | 7                        | 210                          | \$580,200                | \$580,200   |

## HYDROLOGIC / HYDRAULIC CALCULATIONS

**Table 6-6. Runoff Coefficients for Rational Method**  
(Source: UDFCD 2001)

| Land Use or Surface Characteristics                  | Percent Impervious | Runoff Coefficients |         |         |         |         |         |         |         |         |         |          |         |
|--|--------------------|---------------------|---------|---------|---------|---------|---------|---------|---------|---------|---------|----------|---------|
|  |                    | 2-year              |         | 5-year  |         | 10-year |         | 25-year |         | 50-year |         | 100-year |         |
|  |                    | HSG A&B             | HSG C&D | HSG A&B | HSG C&D | HSG A&B | HSG C&D | HSG A&B | HSG C&D | HSG A&B | HSG C&D | HSG A&B  | HSG C&D |
| Business   |                    |                     |         |         |         |         |         |         |         |         |         |          |         |
| Commercial Areas                                     | 95                 | 0.79                | 0.80    | 0.81    | 0.82    | 0.83    | 0.84    | 0.85    | 0.87    | 0.87    | 0.88    | 0.88     | 0.89    |
| Neighborhood Areas                                   | 70                 | 0.45                | 0.49    | 0.49    | 0.53    | 0.53    | 0.57    | 0.58    | 0.62    | 0.60    | 0.65    | 0.62     | 0.68    |
| Residential  |                    |                     |         |         |         |         |         |         |         |         |         |          |         |
| 1/8 Acre or less                                     | 65                 | 0.41                | 0.45    | 0.45    | 0.49    | 0.49    | 0.54    | 0.54    | 0.59    | 0.57    | 0.62    | 0.59     | 0.65    |
| 1/4 Acre   | 40                 | 0.23                | 0.28    | 0.30    | 0.35    | 0.36    | 0.42    | 0.42    | 0.50    | 0.46    | 0.54    | 0.50     | 0.58    |
| 1/3 Acre   | 30                 | 0.18                | 0.22    | 0.25    | 0.30    | 0.32    | 0.38    | 0.39    | 0.47    | 0.43    | 0.52    | 0.47     | 0.57    |
| 1/2 Acre   | 25                 | 0.15                | 0.20    | 0.22    | 0.28    | 0.30    | 0.36    | 0.37    | 0.46    | 0.41    | 0.51    | 0.46     | 0.56    |
| 1 Acre   | 20                 | 0.12                | 0.17    | 0.20    | 0.26    | 0.27    | 0.34    | 0.35    | 0.44    | 0.40    | 0.50    | 0.44     | 0.55    |
| Industrial   |                    |                     |         |         |         |         |         |         |         |         |         |          |         |
| Light Areas  | 80                 | 0.57                | 0.60    | 0.59    | 0.63    | 0.63    | 0.66    | 0.66    | 0.70    | 0.68    | 0.72    | 0.70     | 0.74    |
| Heavy Areas  | 90                 | 0.71                | 0.73    | 0.73    | 0.75    | 0.75    | 0.77    | 0.78    | 0.80    | 0.80    | 0.82    | 0.81     | 0.83    |
| Parks and Cemeteries                                 | 7                  | 0.05                | 0.09    | 0.12    | 0.19    | 0.20    | 0.29    | 0.30    | 0.40    | 0.34    | 0.46    | 0.39     | 0.52    |
| Playgrounds  | 13                 | 0.07                | 0.13    | 0.16    | 0.23    | 0.24    | 0.31    | 0.32    | 0.42    | 0.37    | 0.48    | 0.41     | 0.54    |
| Railroad Yard Areas                                  | 40                 | 0.23                | 0.28    | 0.30    | 0.35    | 0.36    | 0.42    | 0.42    | 0.50    | 0.46    | 0.54    | 0.50     | 0.58    |
| Undeveloped Areas                                    |                    |                     |         |         |         |         |         |         |         |         |         |          |         |
| Historic Flow Analysis--<br>Greenbelts, Agriculture  | 2                  | 0.03                | 0.05    | 0.09    | 0.16    | 0.17    | 0.26    | 0.26    | 0.38    | 0.31    | 0.45    | 0.36     | 0.51    |
| Pasture/Meadow                                       | 0                  | 0.02                | 0.04    | 0.08    | 0.15    | 0.15    | 0.25    | 0.25    | 0.37    | 0.30    | 0.44    | 0.35     | 0.50    |
| Forest   | 0                  | 0.02                | 0.04    | 0.08    | 0.15    | 0.15    | 0.25    | 0.25    | 0.37    | 0.30    | 0.44    | 0.35     | 0.50    |
| Exposed Rock   | 100                | 0.89                | 0.89    | 0.90    | 0.90    | 0.92    | 0.92    | 0.94    | 0.94    | 0.95    | 0.95    | 0.96     | 0.96    |
| Offsite Flow Analysis (when<br>landuse is undefined) | 45                 | 0.26                | 0.31    | 0.32    | 0.37    | 0.38    | 0.44    | 0.44    | 0.51    | 0.48    | 0.55    | 0.51     | 0.59    |
| Streets  |                    |                     |         |         |         |         |         |         |         |         |         |          |         |
| Paved  | 100                | 0.89                | 0.89    | 0.90    | 0.90    | 0.92    | 0.92    | 0.94    | 0.94    | 0.95    | 0.95    | 0.96     | 0.96    |
| Gravel   | 80                 | 0.57                | 0.60    | 0.59    | 0.63    | 0.63    | 0.66    | 0.66    | 0.70    | 0.68    | 0.72    | 0.70     | 0.74    |
| Drive and Walks                                      | 100                | 0.89                | 0.89    | 0.90    | 0.90    | 0.92    | 0.92    | 0.94    | 0.94    | 0.95    | 0.95    | 0.96     | 0.96    |
| Roofs  | 90                 | 0.71                | 0.73    | 0.73    | 0.75    | 0.75    | 0.77    | 0.78    | 0.80    | 0.80    | 0.82    | 0.81     | 0.83    |
| Lawns  | 0                  | 0.02                | 0.04    | 0.08    | 0.15    | 0.15    | 0.25    | 0.25    | 0.37    | 0.30    | 0.44    | 0.35     | 0.50    |

### 3.2 Time of Concentration

One of the basic assumptions underlying the Rational Method is that runoff is a function of the average rainfall rate during the time required for water to flow from the hydraulically most remote part of the drainage area under consideration to the design point. However, in practice, the time of concentration can be an empirical value that results in reasonable and acceptable peak flow calculations.

For urban areas, the time of concentration ( $t_c$ ) consists of an initial time or overland flow time ( $t_i$ ) plus the travel time ( $t_t$ ) in the storm sewer, paved gutter, roadside drainage ditch, or drainage channel. For non-urban areas, the time of concentration consists of an overland flow time ( $t_i$ ) plus the time of travel in a concentrated form, such as a swale or drainageway. The travel portion ( $t_t$ ) of the time of concentration can be estimated from the hydraulic properties of the storm sewer, gutter, swale, ditch, or drainageway. Initial time, on the other hand, will vary with surface slope, depression storage, surface cover, antecedent rainfall, and infiltration capacity of the soil, as well as distance of surface flow. The time of concentration is represented by Equation 6-7 for both urban and non-urban areas.

JOB NAME: Midtown Collection at Hannah Ridge Filing No. 3  
 JOB NUMBER: 1116.35  
 DATE: 08/20/20  
 CALCULATED BY: KRC

**FINAL DRAINAGE REPORT ~ BASIN RUNOFF COEFFICIENT SUMMARY (PROPOSED CONDITIONS)**

| BASIN | TOTAL AREA (AC) | IMPERVIOUS AREA / STREETS |      |      |       |       |       |        | LANDSCAPE/UNDEVELOPED AREAS |      |      |       |       |       |        | WEIGHTED |      |        | WEIGHTED CA |         |
|-------|-----------------|---------------------------|------|------|-------|-------|-------|--------|-----------------------------|------|------|-------|-------|-------|--------|----------|------|--------|-------------|---------|
|       |                 | AREA (AC)                 | C(2) | C(5) | C(10) | C(25) | C(50) | C(100) | AREA (AC)                   | C(2) | C(5) | C(10) | C(25) | C(50) | C(100) | C(2)     | C(5) | C(100) | CA(5)       | CA(100) |
| A     | 0.76            | 0.48                      | 0.89 | 0.90 | 0.92  | 0.94  | 0.95  | 0.96   | 0.28                        | 0.04 | 0.15 | 0.25  | 0.37  | 0.44  | 0.5    | 0.58     | 0.62 | 0.79   | 0.47        | 0.60    |
| B-1   | 1.36            | 0.79                      | 0.89 | 0.90 | 0.92  | 0.94  | 0.95  | 0.96   | 0.57                        | 0.04 | 0.15 | 0.25  | 0.37  | 0.44  | 0.5    | 0.53     | 0.59 | 0.77   | 0.80        | 1.04    |
| B-2   | 0.34            | 0.20                      | 0.89 | 0.90 | 0.92  | 0.94  | 0.95  | 0.96   | 0.14                        | 0.04 | 0.15 | 0.25  | 0.37  | 0.44  | 0.5    | 0.54     | 0.59 | 0.77   | 0.20        | 0.26    |
| C     | 0.29            | 0.21                      | 0.89 | 0.90 | 0.92  | 0.94  | 0.95  | 0.96   | 0.08                        | 0.04 | 0.15 | 0.25  | 0.37  | 0.44  | 0.5    | 0.66     | 0.69 | 0.83   | 0.20        | 0.24    |
| D     | 1.08            | 0.79                      | 0.89 | 0.90 | 0.92  | 0.94  | 0.95  | 0.96   | 0.29                        | 0.04 | 0.15 | 0.25  | 0.37  | 0.44  | 0.5    | 0.66     | 0.70 | 0.84   | 0.75        | 0.90    |
| E     | 0.89            | 0.67                      | 0.89 | 0.90 | 0.92  | 0.94  | 0.95  | 0.96   | 0.22                        | 0.04 | 0.15 | 0.25  | 0.37  | 0.44  | 0.5    | 0.68     | 0.71 | 0.85   | 0.64        | 0.75    |
| F     | 1.23            | 0.22                      | 0.89 | 0.90 | 0.92  | 0.94  | 0.95  | 0.96   | 1.01                        | 0.04 | 0.15 | 0.25  | 0.37  | 0.44  | 0.5    | 0.19     | 0.28 | 0.58   | 0.35        | 0.72    |
| G     | 1.87            | 0.00                      | 0.89 | 0.90 | 0.92  | 0.94  | 0.95  | 0.96   | 1.87                        | 0.04 | 0.15 | 0.25  | 0.37  | 0.44  | 0.5    | 0.04     | 0.15 | 0.50   | 0.28        | 0.94    |
| H     | 0.42            | 0.00                      | 0.89 | 0.90 | 0.92  | 0.94  | 0.95  | 0.96   | 0.42                        | 0.04 | 0.15 | 0.25  | 0.37  | 0.44  | 0.5    | 0.04     | 0.15 | 0.50   | 0.06        | 0.21    |

JOB NAME: *Midtown Collection at Hannah Ridge Filing No. 3*  
 JOB NUMBER: *1116.35*  
 DATE: *08/20/20*  
 CALC'D BY: *KRC*

**BASIN RUNOFF SUMMARY (PROPOSED CONDITIONS)**

| BASIN | WEIGHTED |       |         | OVERLAND |                |                |             | STREET / CHANNEL FLOW |              |                   |             | Tc             | INTENSITY       |                   | TOTAL FLOWS   |                 |
|-------|----------|-------|---------|----------|----------------|----------------|-------------|-----------------------|--------------|-------------------|-------------|----------------|-----------------|-------------------|---------------|-----------------|
|       | CA(2)    | CA(5) | CA(100) | C(5)     | Length<br>(ft) | Height<br>(ft) | Tc<br>(min) | Length<br>(ft)        | Slope<br>(%) | Velocity<br>(fps) | Tc<br>(min) | TOTAL<br>(min) | I(5)<br>(in/hr) | I(100)<br>(in/hr) | Q(5)<br>(cfs) | Q(100)<br>(cfs) |
| A     | 0.44     | 0.47  | 0.60    | 0.15     | 80             | 3              | 9.9         | 150                   | 4.0%         | 7.0               | 0.4         | 10.3           | 4.09            | 6.86              | 1.9           | 4.1             |
| B-1   | 0.73     | 0.80  | 1.04    | 0.15     | 200            | 6              | 16.9        | 90                    | 4.0%         | 7.0               | 0.2         | 17.1           | 3.32            | 5.58              | 2.6           | 5.8             |
| B-2   | 0.18     | 0.20  | 0.26    | 0.15     | 130            | 5              | 12.5        | 0                     | 0.0%         | 0.0               | 0.0         | 12.5           | 3.79            | 6.36              | 0.8           | 1.7             |
| C     | 0.19     | 0.20  | 0.24    | 0.15     | 45             | 0.9            | 9.2         | 80                    | 4.0%         | 7.0               | 0.2         | 9.3            | 4.23            | 7.10              | 0.9           | 1.7             |
| D     | 0.71     | 0.75  | 0.90    | 0.15     | 50             | 1              | 9.6         | 290                   | 3.0%         | 6.1               | 0.8         | 10.4           | 4.06            | 6.82              | 3.1           | 6.2             |
| E     | 0.61     | 0.64  | 0.75    | 0.15     | 240            | 8              | 17.9        | 0                     | 0.0%         | 0.0               | 0.0         | 17.9           | 3.26            | 5.47              | 2.1           | 4.1             |
| F     | 0.24     | 0.35  | 0.72    | 0.15     | 50             | 1              | 9.6         | 0                     | 0.0%         | 0.0               | 0.0         | 9.6            | 4.18            | 7.02              | 1.5           | 5.0             |
| G     | 0.07     | 0.28  | 0.94    | 0.15     | 50             | 1              | 9.6         | 0                     | 0.0%         | 0.0               | 0.0         | 9.6            | 4.18            | 7.02              | 1.2           | 6.6             |
| H     | 0.02     | 0.06  | 0.21    | 0.15     | 95             | 3              | 11.4        | 0                     | 0.0%         | 0.0               | 0.0         | 11.4           | 3.93            | 6.59              | 0.2           | 1.4             |

JOB NAME: Midtown Collection at Hannah Ridge Filing No. 3  
 JOB NUMBER: 1116.35  
 DATE: 08/20/20  
 CALC'D BY: KRC

**SURFACE ROUTING SUMMARY (PROPOSED CONDITIONS)**

| Design Point(s)   | Contributing Basins   | Equivalent CA(5) | Equivalent CA(100) | Maximum Tc | Intensity |        | Flow |        | Inlet Size/Conveyance                      |
|-------------------|---|------------------|--------------------|------------|-----------|--------|------|--------|--|
|                   |   |                  |                    |            | I(5)      | I(100) | Q(5) | Q(100) |  |
| 1                 | BASIN A   | 0.47             | 0.60               | 10.3       | 4.08      | 6.86   | 1.9  | 4.1    | Street flow south to DP #2                 |
| 2                 | BASIN A, B-1 and C (Surface area tributary to east entry into pond) | 1.31             | 1.89               | 17.1       | 3.32      | 5.58   | 4.3  | 10.5   | Proposed 10' type R public inlet           |
| 3                 | BASIN D   | 0.75             | 0.90               | 10.4       | 4.06      | 6.82   | 3.1  | 6.2    | Proposed 10' type R public inlet           |
| 4                 | BASIN B-2   | 0.20             | 0.26               | 12.5       | 3.79      | 6.36   | 0.8  | 1.7    | Proposed 2'x2' type C private grated inlet |
| 5                 | Off-site and DP 3 (North entry into pond)                           | 8.18             | 9.59               | 17.1       | 3.32      | 5.58   | 27.2 | 53.5   | North pond Entry                           |
| Total Pond Inflow | DP 2, 3, 4, 5 and Basin F   | 10.45            | 12.64              | 17.1       | 3.32      | 5.58   | 34.7 | 70.6   | Total flow into pond                       |

JOB NAME: Midtown Collection at Hannah Ridge Filing No. 3  
 JOB NUMBER: 1116.35  
 DATE: 08/20/20  
 CALC'D BY: KRC

\* PIPES ARE LISTED AT MAXIMUM SIZE REQUIRED TO ACCOMMODATE Q100 FLOWS AT MINIMUM GRADE.  
 REFER TO INDIVIDUAL PIPE SHEETS FOR HYDRAULIC INFORMATION.

**FINAL DRAINAGE REPORT ~ PIPE ROUTING SUMMARY**

| Pipe Run | Contributing Basins | Equivalent CA(5) | Equivalent CA(100) | Maximum Tc | Intensity |        | Flow |        | Pipe Size*          |
|----------|---------------------|------------------|--------------------|------------|-----------|--------|------|--------|---------------------|
|          |                     |                  |                    |            | I(5)      | I(100) | Q(5) | Q(100) |                     |
| 1        | DP 4                | 0.20             | 0.26               | 12.5       | 3.79      | 6.36   | 0.8  | 1.7    | 12" Private PVC/ADS |
| 2        | DP 2 and DP 4       | 1.51             | 2.15               | 17.1       | 3.32      | 5.58   | 5.0  | 12.0   | 24" Public RCP      |
| 3        | DP 3                | 0.75             | 0.90               | 10.4       | 4.06      | 6.82   | 3.1  | 6.2    | 18" Private PVC/ADS |
| 4        | DP 5                | 8.18             | 9.59               | 17.1       | 3.32      | 5.58   | 27.2 | 53.5   | 48" Public RCP      |

**ALLOWABLE CAPACITY FOR ONE-HALF OF STREET (Minor & Major Storm)**

(Based on Regulated Criteria for Maximum Allowable Flow Depth and Spread)

Project: Midtown Collection at Hannah Ridge Filing No. 3  
 Inlet ID: DP #2

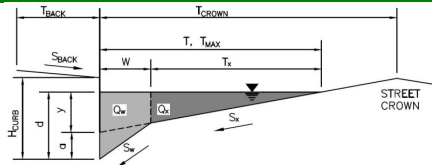

| <b>Gutter Geometry (Enter data in the blue cells)</b>                      |  |  |             |             |  |              |  |  |     |              |   |   |        |  |                          |                          |  |
|--|--|--|-------------|-------------|--|--------------|--|--|-----|--------------|---|---|--------|--|--------------------------|--------------------------|--|
| Maximum Allowable Width for Spread Behind Curb                             | $T_{BACK} = $ <input style="width: 50px;" type="text" value="10.0"/> ft  |  |             |             |  |              |  |  |     |              |   |   |        |  |                          |                          |  |
| Side Slope Behind Curb (leave blank for no conveyance credit behind curb)  | $S_{BACK} = $ <input style="width: 50px;" type="text" value="0.020"/> ft/ft  |  |             |             |  |              |  |  |     |              |   |   |        |  |                          |                          |  |
| Manning's Roughness Behind Curb (typically between 0.012 and 0.020)        | $n_{BACK} = $ <input style="width: 50px;" type="text" value="0.016"/>  |  |             |             |  |              |  |  |     |              |   |   |        |  |                          |                          |  |
| Height of Curb at Gutter Flow Line   | $H_{CURB} = $ <input style="width: 50px;" type="text" value="6.00"/> inches  |  |             |             |  |              |  |  |     |              |   |   |        |  |                          |                          |  |
| Distance from Curb Face to Street Crown                                    | $T_{CROWN} = $ <input style="width: 50px;" type="text" value="36.0"/> ft   |  |             |             |  |              |  |  |     |              |   |   |        |  |                          |                          |  |
| Gutter Width   | $W = $ <input style="width: 50px;" type="text" value="1.00"/> ft   |  |             |             |  |              |  |  |     |              |   |   |        |  |                          |                          |  |
| Street Transverse Slope  | $S_x = $ <input style="width: 50px;" type="text" value="0.040"/> ft/ft   |  |             |             |  |              |  |  |     |              |   |   |        |  |                          |                          |  |
| Gutter Cross Slope (typically 2 inches over 24 inches or 0.083 ft/ft)      | $S_w = $ <input style="width: 50px;" type="text" value="0.083"/> ft/ft   |  |             |             |  |              |  |  |     |              |   |   |        |  |                          |                          |  |
| Street Longitudinal Slope - Enter 0 for sump condition                     | $S_o = $ <input style="width: 50px;" type="text" value="0.000"/> ft/ft   |  |             |             |  |              |  |  |     |              |   |   |        |  |                          |                          |  |
| Manning's Roughness for Street Section (typically between 0.012 and 0.020) | $n_{STREET} = $ <input style="width: 50px;" type="text" value="0.018"/>  |  |             |             |  |              |  |  |     |              |   |   |        |  |                          |                          |  |
| Max. Allowable Spread for Minor & Major Storm                              | <table style="width: 100%; border-collapse: collapse;"> <thead> <tr> <th style="width: 50%;"></th> <th style="width: 25%; text-align: center;">Minor Storm</th> <th style="width: 25%; text-align: center;">Major Storm</th> <th style="width: 10%;"></th> </tr> </thead> <tbody> <tr> <td><math>T_{MAX} = </math></td> <td style="text-align: center;"><input style="width: 40px;" type="text" value="15.0"/></td> <td style="text-align: center;"><input style="width: 40px;" type="text" value="36.0"/></td> <td style="text-align: right;">ft</td> </tr> <tr> <td><math>d_{MAX} = </math></td> <td style="text-align: center;"><input style="width: 40px;" type="text" value="6.0"/></td> <td style="text-align: center;"><input style="width: 40px;" type="text" value="7.7"/></td> <td style="text-align: right;">inches</td> </tr> <tr> <td></td> <td style="text-align: center;"><input type="checkbox"/></td> <td style="text-align: center;"><input type="checkbox"/></td> <td></td> </tr> </tbody> </table> |  | Minor Storm | Major Storm |  | $T_{MAX} = $ | <input style="width: 40px;" type="text" value="15.0"/> | <input style="width: 40px;" type="text" value="36.0"/> | ft  | $d_{MAX} = $ | <input style="width: 40px;" type="text" value="6.0"/> | <input style="width: 40px;" type="text" value="7.7"/> | inches |  | <input type="checkbox"/> | <input type="checkbox"/> |  |
|  | Minor Storm  | Major Storm  |             |             |  |              |  |  |     |              |   |   |        |  |                          |                          |  |
| $T_{MAX} = $   | <input style="width: 40px;" type="text" value="15.0"/>   | <input style="width: 40px;" type="text" value="36.0"/> | ft          |             |  |              |  |  |     |              |   |   |        |  |                          |                          |  |
| $d_{MAX} = $   | <input style="width: 40px;" type="text" value="6.0"/>  | <input style="width: 40px;" type="text" value="7.7"/>  | inches      |             |  |              |  |  |     |              |   |   |        |  |                          |                          |  |
|  | <input type="checkbox"/>   | <input type="checkbox"/>                               |             |             |  |              |  |  |     |              |   |   |        |  |                          |                          |  |
| Max. Allowable Depth at Gutter Flowline for Minor & Major Storm            |  |  |             |             |  |              |  |  |     |              |   |   |        |  |                          |                          |  |
| Check boxes are not applicable in SUMP conditions                          |  |  |             |             |  |              |  |  |     |              |   |   |        |  |                          |                          |  |
| <b>MINOR STORM Allowable Capacity is based on Depth Criterion</b>          |  |  |             |             |  |              |  |  |     |              |   |   |        |  |                          |                          |  |
| <b>MAJOR STORM Allowable Capacity is based on Depth Criterion</b>          |  |  |             |             |  |              |  |  |     |              |   |   |        |  |                          |                          |  |
| $Q_{allow} = $   | <table style="width: 100%; border-collapse: collapse;"> <thead> <tr> <th style="width: 50%;"></th> <th style="width: 25%; text-align: center;">Minor Storm</th> <th style="width: 25%; text-align: center;">Major Storm</th> <th style="width: 10%;"></th> </tr> </thead> <tbody> <tr> <td></td> <td style="text-align: center;"><input style="width: 40px;" type="text" value="SUMP"/></td> <td style="text-align: center;"><input style="width: 40px;" type="text" value="SUMP"/></td> <td style="text-align: right;">cfs</td> </tr> </tbody> </table>   |  | Minor Storm | Major Storm |  |              | <input style="width: 40px;" type="text" value="SUMP"/> | <input style="width: 40px;" type="text" value="SUMP"/> | cfs |              |   |   |        |  |                          |                          |  |
|  | Minor Storm  | Major Storm  |             |             |  |              |  |  |     |              |   |   |        |  |                          |                          |  |
|  | <input style="width: 40px;" type="text" value="SUMP"/>   | <input style="width: 40px;" type="text" value="SUMP"/> | cfs         |             |  |              |  |  |     |              |   |   |        |  |                          |                          |  |



## INLET IN A SUMP OR SAG LOCATION

Version 4.05 Released March 2017

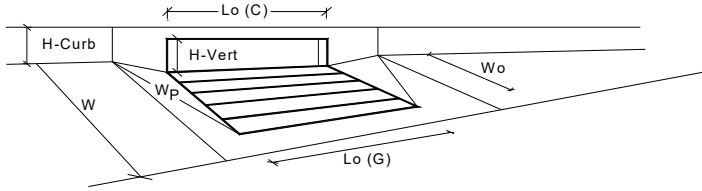

| Design Information (Input)   | MINOR                    | MAJOR |  |
|--|--------------------------|-------|--|
| Type of Inlet  | CDOT Type R Curb Opening |       |  |
| Local Depression (additional to continuous gutter depression 'a' from above) | 3.00                     | 3.00  | inches                                   |
| Number of Unit Inlets (Grate or Curb Opening)                                | 1                        | 1     |  |
| Water Depth at Flowline (outside of local depression)                        | 6.0                      | 7.7   | inches                                   |
| <b>Grate Information</b>   | MINOR                    | MAJOR | <input type="checkbox"/> Override Depths |
| Length of a Unit Grate   | N/A                      | N/A   | feet                                     |
| Width of a Unit Grate  | N/A                      | N/A   | feet                                     |
| Area Opening Ratio for a Grate (typical values 0.15-0.90)                    | N/A                      | N/A   |  |
| Clogging Factor for a Single Grate (typical value 0.50 - 0.70)               | N/A                      | N/A   |  |
| Grate Weir Coefficient (typical value 2.15 - 3.60)                           | N/A                      | N/A   |  |
| Grate Orifice Coefficient (typical value 0.60 - 0.80)                        | N/A                      | N/A   |  |
| <b>Curb Opening Information</b>  | MINOR                    | MAJOR |  |
| Length of a Unit Curb Opening  | 10.00                    | 10.00 | feet                                     |
| Height of Vertical Curb Opening in Inches                                    | 6.00                     | 6.00  | inches                                   |
| Height of Curb Orifice Throat in Inches                                      | 6.00                     | 6.00  | inches                                   |
| Angle of Throat (see USDCM Figure ST-5)                                      | 63.40                    | 63.40 | degrees                                  |
| Side Width for Depression Pan (typically the gutter width of 2 feet)         | 1.00                     | 1.00  | feet                                     |
| Clogging Factor for a Single Curb Opening (typical value 0.10)               | 0.10                     | 0.10  |  |
| Curb Opening Weir Coefficient (typical value 2.3-3.7)                        | 3.60                     | 3.60  |  |
| Curb Opening Orifice Coefficient (typical value 0.60 - 0.70)                 | 0.67                     | 0.67  |  |
| <b>Low Head Performance Reduction (Calculated)</b>                           | MINOR                    | MAJOR |  |
| Depth for Grate Midwidth   | N/A                      | N/A   | ft                                       |
| Depth for Curb Opening Weir Equation   | 0.42                     | 0.56  | ft                                       |
| Combination Inlet Performance Reduction Factor for Long Inlets               | 0.57                     | 0.73  |  |
| Curb Opening Performance Reduction Factor for Long Inlets                    | 0.93                     | 1.00  |  |
| Grated Inlet Performance Reduction Factor for Long Inlets                    | N/A                      | N/A   |  |
| <b>Total Inlet Interception Capacity (assumes clogged condition)</b>         | MINOR                    | MAJOR |  |
| $Q_a$ =  | 10.0                     | 16.6  | cfs                                      |
| $Q_{PEAK\ REQUIRED}$ =   | 4.9                      | 10.5  | cfs                                      |

Inlet Capacity IS GOOD for Minor and Major Storms(>Q PEAK)

**ALLOWABLE CAPACITY FOR ONE-HALF OF STREET (Minor & Major Storm)**

(Based on Regulated Criteria for Maximum Allowable Flow Depth and Spread)

Project: Midtown Collection at Hannah Ridge Filing No. 3  
 Inlet ID: DP #3

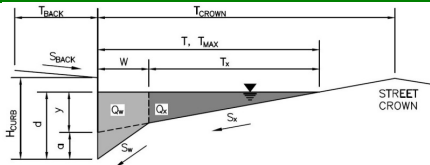

| Gutter Geometry (Enter data in the blue cells)                             |  |                |             |             |  |      |      |      |        |
|--|--|----------------|-------------|-------------|--|------|------|------|--------|
| Maximum Allowable Width for Spread Behind Curb                             | $T_{BACK} = $ <input style="width: 50px;" type="text" value="0.0"/> ft   |                |             |             |  |      |      |      |        |
| Side Slope Behind Curb (leave blank for no conveyance credit behind curb)  | $S_{BACK} = $ <input style="width: 50px;" type="text" value="0.020"/> ft/ft  |                |             |             |  |      |      |      |        |
| Manning's Roughness Behind Curb (typically between 0.012 and 0.020)        | $n_{BACK} = $ <input style="width: 50px;" type="text" value="0.016"/>  |                |             |             |  |      |      |      |        |
| Height of Curb at Gutter Flow Line   | $H_{CURB} = $ <input style="width: 50px;" type="text" value="6.00"/> inches  |                |             |             |  |      |      |      |        |
| Distance from Curb Face to Street Crown                                    | $T_{CROWN} = $ <input style="width: 50px;" type="text" value="24.0"/> ft   |                |             |             |  |      |      |      |        |
| Gutter Width   | $W = $ <input style="width: 50px;" type="text" value="1.00"/> ft   |                |             |             |  |      |      |      |        |
| Street Transverse Slope  | $S_x = $ <input style="width: 50px;" type="text" value="0.020"/> ft/ft   |                |             |             |  |      |      |      |        |
| Gutter Cross Slope (typically 2 inches over 24 inches or 0.083 ft/ft)      | $S_w = $ <input style="width: 50px;" type="text" value="0.083"/> ft/ft   |                |             |             |  |      |      |      |        |
| Street Longitudinal Slope - Enter 0 for sump condition                     | $S_o = $ <input style="width: 50px;" type="text" value="0.000"/> ft/ft   |                |             |             |  |      |      |      |        |
| Manning's Roughness for Street Section (typically between 0.012 and 0.020) | $n_{STREET} = $ <input style="width: 50px;" type="text" value="0.018"/>  |                |             |             |  |      |      |      |        |
| Max. Allowable Spread for Minor & Major Storm                              | <table style="width: 100%; border: none;"> <tr> <td style="text-align: center; border: none;"><math>T_{MAX} = </math></td> <td style="text-align: center; border: none;">Minor Storm</td> <td style="text-align: center; border: none;">Major Storm</td> <td style="border: none;"></td> </tr> <tr> <td style="border: 1px solid black; width: 50px; text-align: center;">24.0</td> <td style="border: 1px solid black; width: 50px; text-align: center;">24.0</td> <td style="border: 1px solid black; width: 50px; text-align: center;">24.0</td> <td style="border: none; text-align: right;">ft</td> </tr> </table>    | $T_{MAX} = $   | Minor Storm | Major Storm |  | 24.0 | 24.0 | 24.0 | ft     |
| $T_{MAX} = $   | Minor Storm  | Major Storm    |             |             |  |      |      |      |        |
| 24.0   | 24.0   | 24.0           | ft          |             |  |      |      |      |        |
| Max. Allowable Depth at Gutter Flowline for Minor & Major Storm            | <table style="width: 100%; border: none;"> <tr> <td style="text-align: center; border: none;"><math>d_{MAX} = </math></td> <td style="text-align: center; border: none;">Minor Storm</td> <td style="text-align: center; border: none;">Major Storm</td> <td style="border: none;"></td> </tr> <tr> <td style="border: 1px solid black; width: 50px; text-align: center;">6.0</td> <td style="border: 1px solid black; width: 50px; text-align: center;">6.0</td> <td style="border: 1px solid black; width: 50px; text-align: center;">6.0</td> <td style="border: none; text-align: right;">inches</td> </tr> </table>   | $d_{MAX} = $   | Minor Storm | Major Storm |  | 6.0  | 6.0  | 6.0  | inches |
| $d_{MAX} = $   | Minor Storm  | Major Storm    |             |             |  |      |      |      |        |
| 6.0  | 6.0  | 6.0            | inches      |             |  |      |      |      |        |
| Check boxes are not applicable in SUMP conditions                          | <input type="checkbox"/> <input type="checkbox"/>  |                |             |             |  |      |      |      |        |
| <b>MINOR STORM Allowable Capacity is based on Depth Criterion</b>          |  |                |             |             |  |      |      |      |        |
| <b>MAJOR STORM Allowable Capacity is based on Depth Criterion</b>          |  |                |             |             |  |      |      |      |        |
|  | <table style="width: 100%; border: none;"> <tr> <td style="text-align: center; border: none;"><math>Q_{allow} = </math></td> <td style="text-align: center; border: none;">Minor Storm</td> <td style="text-align: center; border: none;">Major Storm</td> <td style="border: none;"></td> </tr> <tr> <td style="border: 1px solid black; width: 50px; text-align: center;">SUMP</td> <td style="border: 1px solid black; width: 50px; text-align: center;">SUMP</td> <td style="border: 1px solid black; width: 50px; text-align: center;">SUMP</td> <td style="border: none; text-align: right;">cfs</td> </tr> </table> | $Q_{allow} = $ | Minor Storm | Major Storm |  | SUMP | SUMP | SUMP | cfs    |
| $Q_{allow} = $   | Minor Storm  | Major Storm    |             |             |  |      |      |      |        |
| SUMP   | SUMP   | SUMP           | cfs         |             |  |      |      |      |        |

## INLET IN A SUMP OR SAG LOCATION

Version 4.05 Released March 2017

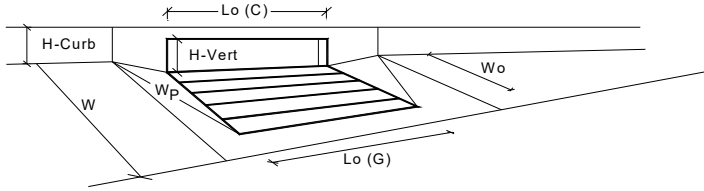

| Design Information (Input)   | MINOR                    | MAJOR |  |
|--|--------------------------|-------|--|
| Type of Inlet  | CDOT Type R Curb Opening |       |  |
| Local Depression (additional to continuous gutter depression 'a' from above) | 3.00                     | 3.00  | inches                                   |
| Number of Unit Inlets (Grate or Curb Opening)                                | 1                        | 1     |  |
| Water Depth at Flowline (outside of local depression)                        | 6.0                      | 6.0   | inches                                   |
| <b>Grate Information</b>   | MINOR                    | MAJOR | <input type="checkbox"/> Override Depths |
| Length of a Unit Grate   | N/A                      | N/A   | feet                                     |
| Width of a Unit Grate  | N/A                      | N/A   | feet                                     |
| Area Opening Ratio for a Grate (typical values 0.15-0.90)                    | N/A                      | N/A   |  |
| Clogging Factor for a Single Grate (typical value 0.50 - 0.70)               | N/A                      | N/A   |  |
| Grate Weir Coefficient (typical value 2.15 - 3.60)                           | N/A                      | N/A   |  |
| Grate Orifice Coefficient (typical value 0.60 - 0.80)                        | N/A                      | N/A   |  |
| <b>Curb Opening Information</b>  | MINOR                    | MAJOR |  |
| Length of a Unit Curb Opening  | 10.00                    | 10.00 | feet                                     |
| Height of Vertical Curb Opening in Inches                                    | 6.00                     | 6.00  | inches                                   |
| Height of Curb Orifice Throat in Inches                                      | 6.00                     | 6.00  | inches                                   |
| Angle of Throat (see USDCM Figure ST-5)                                      | 63.40                    | 63.40 | degrees                                  |
| Side Width for Depression Pan (typically the gutter width of 2 feet)         | 1.00                     | 1.00  | feet                                     |
| Clogging Factor for a Single Curb Opening (typical value 0.10)               | 0.10                     | 0.10  |  |
| Curb Opening Weir Coefficient (typical value 2.3-3.7)                        | 3.60                     | 3.60  |  |
| Curb Opening Orifice Coefficient (typical value 0.60 - 0.70)                 | 0.67                     | 0.67  |  |
| <b>Low Head Performance Reduction (Calculated)</b>                           | MINOR                    | MAJOR |  |
| Depth for Grate Midwidth   | N/A                      | N/A   | ft                                       |
| Depth for Curb Opening Weir Equation   | 0.42                     | 0.42  | ft                                       |
| Combination Inlet Performance Reduction Factor for Long Inlets               | 0.57                     | 0.57  |  |
| Curb Opening Performance Reduction Factor for Long Inlets                    | 0.93                     | 0.93  |  |
| Grated Inlet Performance Reduction Factor for Long Inlets                    | N/A                      | N/A   |  |
| <b>Total Inlet Interception Capacity (assumes clogged condition)</b>         | MINOR                    | MAJOR |  |
| <b>Q<sub>a</sub></b>   | 10.0                     | 10.0  | cfs                                      |
| Q <sub>PEAK REQUIRED</sub>   | 3.1                      | 6.2   | cfs                                      |

**Inlet Capacity IS GOOD for Minor and Major Storms(>Q PEAK)**

**AREA INLET IN A SWALE**

Midtown Collection at Hannah Ridge Filing No. 3

DP #4

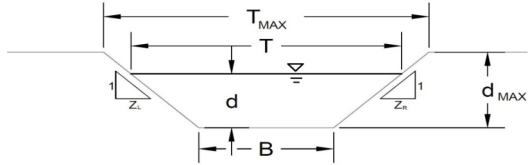

This worksheet uses the NRCS vegetative retardance method to determine Manning's n.  
For more information see Section 7.2.3 of the USDCM.

| Analysis of Trapezoidal Grass-Lined Channel Using SCS Method   |  |   |                 |             |                                       |       |  |              |                                |         |                      |             |      |             |
|--|--|---|-----------------|-------------|---------------------------------------|-------|--|--------------|--------------------------------|---------|----------------------|-------------|------|-------------|
| NRCS Vegetal Retardance (A, B, C, D, or E)   |  |   |                 |             |                                       |       |  |              |                                |         |                      |             |      |             |
| Manning's n (Leave cell D16 blank to manually enter an n value)  |  |   |                 |             |                                       |       |  |              |                                |         |                      |             |      |             |
| Channel Invert Slope   |  |   |                 |             |                                       |       |  |              |                                |         |                      |             |      |             |
| Bottom Width   |  |   |                 |             |                                       |       |  |              |                                |         |                      |             |      |             |
| Left Side Slope  |  |   |                 |             |                                       |       |  |              |                                |         |                      |             |      |             |
| Right Side Slope   |  |   |                 |             |                                       |       |  |              |                                |         |                      |             |      |             |
| Check one of the following soil types:   |  |   |                 |             |                                       |       |  |              |                                |         |                      |             |      |             |
| <b>Soil Type:</b>  | <b>Max. Velocity (V<sub>MAX</sub>)</b> | <b>Max Froude No. (F<sub>MAX</sub>)</b> |                 |             |                                       |       |  |              |                                |         |                      |             |      |             |
| Non-Cohesive   | 5.0 fps                                | 0.60                                    |                 |             |                                       |       |  |              |                                |         |                      |             |      |             |
| Cohesive   | 7.0 fps                                | 0.80                                    |                 |             |                                       |       |  |              |                                |         |                      |             |      |             |
| Paved  | N/A                                    | N/A                                     |                 |             |                                       |       |  |              |                                |         |                      |             |      |             |
| <table border="1" style="width: 100%; border-collapse: collapse;"> <tr> <td colspan="2" style="text-align: center;">A, B, C, D or E</td> </tr> <tr> <td>n =</td> <td style="text-align: center;">0.035</td> </tr> <tr> <td>S<sub>0</sub> =</td> <td style="text-align: center;">0.0300 ft/ft</td> </tr> <tr> <td>B =</td> <td style="text-align: center;">3.00 ft</td> </tr> <tr> <td>Z1 =</td> <td style="text-align: center;">50.00 ft/ft</td> </tr> <tr> <td>Z2 =</td> <td style="text-align: center;">50.00 ft/ft</td> </tr> </table>              |  |   | A, B, C, D or E |             | n =                                   | 0.035 | S <sub>0</sub> =                             | 0.0300 ft/ft | B =                            | 3.00 ft | Z1 =                 | 50.00 ft/ft | Z2 = | 50.00 ft/ft |
| A, B, C, D or E  |  |   |                 |             |                                       |       |  |              |                                |         |                      |             |      |             |
| n =  | 0.035                                  |   |                 |             |                                       |       |  |              |                                |         |                      |             |      |             |
| S <sub>0</sub> =   | 0.0300 ft/ft                           |   |                 |             |                                       |       |  |              |                                |         |                      |             |      |             |
| B =  | 3.00 ft                                |   |                 |             |                                       |       |  |              |                                |         |                      |             |      |             |
| Z1 =   | 50.00 ft/ft                            |   |                 |             |                                       |       |  |              |                                |         |                      |             |      |             |
| Z2 =   | 50.00 ft/ft                            |   |                 |             |                                       |       |  |              |                                |         |                      |             |      |             |
| <table border="1" style="width: 100%; border-collapse: collapse;"> <tr> <td colspan="2" style="text-align: center;">Choose One:</td> </tr> <tr> <td colspan="2" style="text-align: center;"><input type="checkbox"/> Non-Cohesive</td> </tr> <tr> <td colspan="2" style="text-align: center;"><input checked="" type="checkbox"/> Cohesive</td> </tr> <tr> <td colspan="2" style="text-align: center;"><input type="checkbox"/> Paved</td> </tr> </table>  |  |   | Choose One:     |             | <input type="checkbox"/> Non-Cohesive |       | <input checked="" type="checkbox"/> Cohesive |              | <input type="checkbox"/> Paved |         |                      |             |      |             |
| Choose One:  |  |   |                 |             |                                       |       |  |              |                                |         |                      |             |      |             |
| <input type="checkbox"/> Non-Cohesive  |  |   |                 |             |                                       |       |  |              |                                |         |                      |             |      |             |
| <input checked="" type="checkbox"/> Cohesive   |  |   |                 |             |                                       |       |  |              |                                |         |                      |             |      |             |
| <input type="checkbox"/> Paved   |  |   |                 |             |                                       |       |  |              |                                |         |                      |             |      |             |
| <table border="1" style="width: 100%; border-collapse: collapse;"> <tr> <td></td> <td style="text-align: center;">Minor Storm</td> <td style="text-align: center;">Major Storm</td> <td></td> </tr> <tr> <td>T<sub>MAX</sub> =</td> <td style="text-align: center;">20.00</td> <td style="text-align: center;">30.00</td> <td style="text-align: center;">feet</td> </tr> <tr> <td>d<sub>MAX</sub> =</td> <td style="text-align: center;">0.40</td> <td style="text-align: center;">0.60</td> <td style="text-align: center;">feet</td> </tr> </table> |  |   |                 | Minor Storm | Major Storm                           |       | T <sub>MAX</sub> =                           | 20.00        | 30.00                          | feet    | d <sub>MAX</sub> =   | 0.40        | 0.60 | feet        |
|  | Minor Storm                            | Major Storm                             |                 |             |                                       |       |  |              |                                |         |                      |             |      |             |
| T <sub>MAX</sub> =   | 20.00                                  | 30.00                                   | feet            |             |                                       |       |  |              |                                |         |                      |             |      |             |
| d <sub>MAX</sub> =   | 0.40                                   | 0.60                                    | feet            |             |                                       |       |  |              |                                |         |                      |             |      |             |
| <table border="1" style="width: 100%; border-collapse: collapse;"> <tr> <td></td> <td style="text-align: center;">Minor Storm</td> <td style="text-align: center;">Major Storm</td> <td></td> </tr> <tr> <td>Q<sub>allow</sub> =</td> <td style="text-align: center;">3.1</td> <td style="text-align: center;">9.2</td> <td style="text-align: center;">cfs</td> </tr> <tr> <td>d<sub>allow</sub> =</td> <td style="text-align: center;">0.17</td> <td style="text-align: center;">0.27</td> <td style="text-align: center;">ft</td> </tr> </table>    |  |   |                 | Minor Storm | Major Storm                           |       | Q <sub>allow</sub> =                         | 3.1          | 9.2                            | cfs     | d <sub>allow</sub> = | 0.17        | 0.27 | ft          |
|  | Minor Storm                            | Major Storm                             |                 |             |                                       |       |  |              |                                |         |                      |             |      |             |
| Q <sub>allow</sub> =   | 3.1                                    | 9.2                                     | cfs             |             |                                       |       |  |              |                                |         |                      |             |      |             |
| d <sub>allow</sub> =   | 0.17                                   | 0.27                                    | ft              |             |                                       |       |  |              |                                |         |                      |             |      |             |
| <table border="1" style="width: 100%; border-collapse: collapse;"> <tr> <td></td> <td style="text-align: center;">Minor Storm</td> <td style="text-align: center;">Major Storm</td> <td></td> </tr> <tr> <td>Q<sub>c</sub> =</td> <td style="text-align: center;">0.8</td> <td style="text-align: center;">1.7</td> <td style="text-align: center;">cfs</td> </tr> <tr> <td>d =</td> <td style="text-align: center;">0.09</td> <td style="text-align: center;">0.13</td> <td style="text-align: center;">feet</td> </tr> </table>                      |  |   |                 | Minor Storm | Major Storm                           |       | Q <sub>c</sub> =                             | 0.8          | 1.7                            | cfs     | d =                  | 0.09        | 0.13 | feet        |
|  | Minor Storm                            | Major Storm                             |                 |             |                                       |       |  |              |                                |         |                      |             |      |             |
| Q <sub>c</sub> =   | 0.8                                    | 1.7                                     | cfs             |             |                                       |       |  |              |                                |         |                      |             |      |             |
| d =  | 0.09                                   | 0.13                                    | feet            |             |                                       |       |  |              |                                |         |                      |             |      |             |
| <p><b>Allowable Channel Capacity Based On Channel Geometry</b></p> <p><b>MINOR STORM</b> Allowable Capacity is based on Top Width Criterion</p> <p><b>MAJOR STORM</b> Allowable Capacity is based on Top Width Criterion</p>   |  |   |                 |             |                                       |       |  |              |                                |         |                      |             |      |             |
| <p><b>Water Depth in Channel Based On Design Peak Flow</b></p> <p>Design Peak Flow</p> <p>Water Depth</p>  |  |   |                 |             |                                       |       |  |              |                                |         |                      |             |      |             |
| <p>Minor storm max. allowable capacity GOOD - greater than the design flow given on sheet 'Inlet Management'</p> <p>Major storm max. allowable capacity GOOD - greater than the design flow given on sheet 'Inlet Management'</p>  |  |   |                 |             |                                       |       |  |              |                                |         |                      |             |      |             |

**AREA INLET IN A SWALE**

Midtown Collection at Hannah Ridge Filing No. 3

DP #4

**Inlet Design Information (Input)**

Type of Inlet:  Inlet Type =

Angle of Inclined Grate (must be <= 30 degrees)  $\theta = 0.00$  degrees

Width of Grate  $W = 3.00$  feet

Length of Grate  $L = 3.00$  feet

Open Area Ratio  $A_{RATIO} = 0.70$

Height of Inclined Grate  $H_B = 0.00$  feet

Clogging Factor  $C_f = 0.50$

Grate Discharge Coefficient  $C_d = 0.84$

Orifice Coefficient  $C_o = 0.56$

Weir Coefficient  $C_w = 1.81$

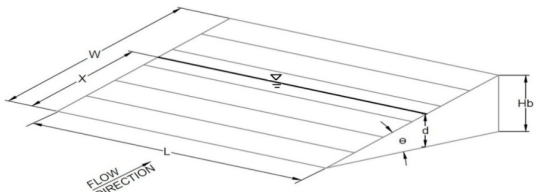

Water Depth at Inlet (for depressed inlets, 1 foot is added for depression)

|  | MINOR | MAJOR |     |
|--|-------|-------|-----|
| $d =$  | 1.09  | 1.13  |     |
| <b>Total Inlet Interception Capacity (assumes clogged condition)</b> |       |       |     |
| $Q_a =$  | 14.9  | 15.1  | cfs |
| Bypassed Flow, $Q_b =$   | 0.0   | 0.0   | cfs |
| Capture Percentage = $Q_a/Q_o = C\%$                                 | 100   | 100   | %   |

Warning 04: Froude No. exceeds USDCM Volume I recommendation.

# PR 1

| Project Description         |                     |
|-----------------------------|---------------------|
| Friction Method             | Manning Formula     |
| Solve For                   | Normal Depth        |
| Input Data                  |                     |
| Roughness Coefficient       | 0.010               |
| Channel Slope               | 0.005 ft/ft         |
| Diameter                    | 12.0 in             |
| Discharge                   | 1.70 cfs            |
| Results                     |                     |
| Normal Depth                | 6.1 in              |
| Flow Area                   | 0.4 ft <sup>2</sup> |
| Wetted Perimeter            | 1.6 ft              |
| Hydraulic Radius            | 3.0 in              |
| Top Width                   | 1.00 ft             |
| Critical Depth              | 6.7 in              |
| Percent Full                | 51.1 %              |
| Critical Slope              | 0.004 ft/ft         |
| Velocity                    | 4.21 ft/s           |
| Velocity Head               | 0.28 ft             |
| Specific Energy             | 0.79 ft             |
| Froude Number               | 1.168               |
| Maximum Discharge           | 3.52 cfs            |
| Discharge Full              | 3.27 cfs            |
| Slope Full                  | 0.001 ft/ft         |
| Flow Type                   | Supercritical       |
| GVF Input Data              |                     |
| Downstream Depth            | 0.0 in              |
| Length                      | 0.0 ft              |
| Number Of Steps             | 0                   |
| GVF Output Data             |                     |
| Upstream Depth              | 0.0 in              |
| Profile Description         | N/A                 |
| Profile Headloss            | 0.00 ft             |
| Average End Depth Over Rise | 0.0 %               |
| Normal Depth Over Rise      | 51.1 %              |
| Downstream Velocity         | Infinity ft/s       |
| Upstream Velocity           | Infinity ft/s       |
| Normal Depth                | 6.1 in              |
| Critical Depth              | 6.7 in              |
| Channel Slope               | 0.005 ft/ft         |
| Critical Slope              | 0.004 ft/ft         |

## PR 2

| Project Description |                 |
|---------------------|-----------------|
| Friction Method     | Manning Formula |
| Solve For           | Normal Depth    |

---

| Input Data            |             |
|-----------------------|-------------|
| Roughness Coefficient | 0.013       |
| Channel Slope         | 0.005 ft/ft |
| Diameter              | 24.0 in     |
| Discharge             | 12.00 cfs   |

---

| Results           |                     |
|-------------------|---------------------|
| Normal Depth      | 15.5 in             |
| Flow Area         | 2.1 ft <sup>2</sup> |
| Wetted Perimeter  | 3.7 ft              |
| Hydraulic Radius  | 6.9 in              |
| Top Width         | 1.91 ft             |
| Critical Depth    | 14.9 in             |
| Percent Full      | 64.6 %              |
| Critical Slope    | 0.006 ft/ft         |
| Velocity          | 5.59 ft/s           |
| Velocity Head     | 0.49 ft             |
| Specific Energy   | 1.78 ft             |
| Froude Number     | 0.930               |
| Maximum Discharge | 17.21 cfs           |
| Discharge Full    | 16.00 cfs           |
| Slope Full        | 0.003 ft/ft         |
| Flow Type         | Subcritical         |

---

| GVF Input Data   |        |
|------------------|--------|
| Downstream Depth | 0.0 in |
| Length           | 0.0 ft |
| Number Of Steps  | 0      |

---

| GVF Output Data             |               |
|-----------------------------|---------------|
| Upstream Depth              | 0.0 in        |
| Profile Description         | N/A           |
| Profile Headloss            | 0.00 ft       |
| Average End Depth Over Rise | 0.0 %         |
| Normal Depth Over Rise      | 54.5 %        |
| Downstream Velocity         | Infinity ft/s |
| Upstream Velocity           | Infinity ft/s |
| Normal Depth                | 15.5 in       |
| Critical Depth              | 14.9 in       |
| Channel Slope               | 0.005 ft/ft   |
| Critical Slope              | 0.006 ft/ft   |

### PR 3

| Project Description |                 |
|---------------------|-----------------|
| Friction Method     | Manning Formula |
| Solve For           | Normal Depth    |

---

| Input Data            |             |
|-----------------------|-------------|
| Roughness Coefficient | 0.013       |
| Channel Slope         | 0.010 ft/ft |
| Diameter              | 18.0 in     |
| Discharge             | 6.20 cfs    |

---

| Results           |                     |
|-------------------|---------------------|
| Normal Depth      | 9.9 in              |
| Flow Area         | 1.0 ft <sup>2</sup> |
| Wetted Perimeter  | 2.5 ft              |
| Hydraulic Radius  | 4.8 in              |
| Top Width         | 1.49 ft             |
| Critical Depth    | 11.5 in             |
| Percent Full      | 55.3 %              |
| Critical Slope    | 0.006 ft/ft         |
| Velocity          | 6.19 ft/s           |
| Velocity Head     | 0.60 ft             |
| Specific Energy   | 1.42 ft             |
| Froude Number     | 1.332               |
| Maximum Discharge | 11.30 cfs           |
| Discharge Full    | 10.50 cfs           |
| Slope Full        | 0.003 ft/ft         |
| Flow Type         | Supercritical       |

---

| GVF Input Data   |        |
|------------------|--------|
| Downstream Depth | 0.0 in |
| Length           | 0.0 ft |
| Number Of Steps  | 0      |

---

| GVF Output Data             |               |
|-----------------------------|---------------|
| Upstream Depth              | 0.0 in        |
| Profile Description         | N/A           |
| Profile Headloss            | 0.00 ft       |
| Average End Depth Over Rise | 0.0 %         |
| Normal Depth Over Rise      | 55.3 %        |
| Downstream Velocity         | Infinity ft/s |
| Upstream Velocity           | Infinity ft/s |
| Normal Depth                | 9.9 in        |
| Critical Depth              | 11.5 in       |
| Channel Slope               | 0.010 ft/ft   |
| Critical Slope              | 0.006 ft/ft   |



## PR 4

| Project Description |                 |
|---------------------|-----------------|
| Friction Method     | Manning Formula |
| Solve For           | Normal Depth    |

---

| Input Data            |             |
|-----------------------|-------------|
| Roughness Coefficient | 0.013       |
| Channel Slope         | 0.005 ft/ft |
| Diameter              | 48.0 in     |
| Discharge             | 53.50 cfs   |

---

| Results           |                     |
|-------------------|---------------------|
| Normal Depth      | 24.8 in             |
| Flow Area         | 6.5 ft <sup>2</sup> |
| Wetted Perimeter  | 6.4 ft              |
| Hydraulic Radius  | 12.2 in             |
| Top Width         | 4.00 ft             |
| Critical Depth    | 26.4 in             |
| Percent Full      | 51.6 %              |
| Critical Slope    | 0.004 ft/ft         |
| Velocity          | 8.19 ft/s           |
| Velocity Head     | 1.04 ft             |
| Specific Energy   | 3.10 ft             |
| Froude Number     | 1.129               |
| Maximum Discharge | 109.25 cfs          |
| Discharge Full    | 101.57 cfs          |
| Slope Full        | 0.001 ft/ft         |
| Flow Type         | Supercritical       |

---

| GVF Input Data   |        |
|------------------|--------|
| Downstream Depth | 0.0 in |
| Length           | 0.0 ft |
| Number Of Steps  | 0      |

---

| GVF Output Data             |               |
|-----------------------------|---------------|
| Upstream Depth              | 0.0 in        |
| Profile Description         | N/A           |
| Profile Headloss            | 0.00 ft       |
| Average End Depth Over Rise | 0.0 %         |
| Normal Depth Over Rise      | 51.6 %        |
| Downstream Velocity         | Infinity ft/s |
| Upstream Velocity           | Infinity ft/s |
| Normal Depth                | 24.8 in       |
| Critical Depth              | 26.4 in       |
| Channel Slope               | 0.005 ft/ft   |
| Critical Slope              | 0.004 ft/ft   |

## PR 5

---

### Project Description

---

|                 |                    |
|-----------------|--------------------|
| Friction Method | Manning<br>Formula |
| Solve For       | Normal Depth       |

---

### Input Data

---

|                       |             |
|-----------------------|-------------|
| Roughness Coefficient | 0.013       |
| Channel Slope         | 0.005 ft/ft |
| Diameter              | 48.0 in     |
| Discharge             | 53.50 cfs   |

---

### Results

---

|                   |                     |
|-------------------|---------------------|
| Normal Depth      | 24.8 in             |
| Flow Area         | 6.5 ft <sup>2</sup> |
| Wetted Perimeter  | 6.4 ft              |
| Hydraulic Radius  | 12.2 in             |
| Top Width         | 4.00 ft             |
| Critical Depth    | 26.4 in             |
| Percent Full      | 51.6 %              |
| Critical Slope    | 0.004 ft/ft         |
| Velocity          | 8.19 ft/s           |
| Velocity Head     | 1.04 ft             |
| Specific Energy   | 3.10 ft             |
| Froude Number     | 1.129               |
| Maximum Discharge | 109.25 cfs          |
| Discharge Full    | 101.57 cfs          |
| Slope Full        | 0.001 ft/ft         |
| Flow Type         | Supercritical       |

---

### GVF Input Data

---

|                  |        |
|------------------|--------|
| Downstream Depth | 0.0 in |
| Length           | 0.0 ft |
| Number Of Steps  | 0      |

---

### GVF Output Data

---

|                             |               |
|-----------------------------|---------------|
| Upstream Depth              | 0.0 in        |
| Profile Description         | N/A           |
| Profile Headloss            | 0.00 ft       |
| Average End Depth Over Rise | 0.0 %         |
| Normal Depth Over Rise      | 51.6 %        |
| Downstream Velocity         | Infinity ft/s |
| Upstream Velocity           | Infinity ft/s |
| Normal Depth                | 24.8 in       |
| Critical Depth              | 26.4 in       |
| Channel Slope               | 0.005 ft/ft   |
| Critical Slope              | 0.004 ft/ft   |

---

## PR- Outfall

| Project Description         |                     |
|-----------------------------|---------------------|
| Friction Method             | Manning Formula     |
| Solve For                   | Normal Depth        |
| Input Data                  |                     |
| Roughness Coefficient       | 0.010               |
| Channel Slope               | 0.012 ft/ft         |
| Diameter                    | 24.0 in             |
| Discharge                   | 33.20 cfs           |
| Results                     |                     |
| Normal Depth                | 20.4 in             |
| Flow Area                   | 2.8 ft <sup>2</sup> |
| Wetted Perimeter            | 4.7 ft              |
| Hydraulic Radius            | 7.3 in              |
| Top Width                   | 1.43 ft             |
| Critical Depth              | 22.8 in             |
| Percent Full                | 85.0 %              |
| Critical Slope              | 0.011 ft/ft         |
| Velocity                    | 11.66 ft/s          |
| Velocity Head               | 2.11 ft             |
| Specific Energy             | 3.81 ft             |
| Froude Number               | 1.456               |
| Maximum Discharge           | 34.65 cfs           |
| Discharge Full              | 32.21 cfs           |
| Slope Full                  | 0.013 ft/ft         |
| Flow Type                   | Supercritical       |
| GVF Input Data              |                     |
| Downstream Depth            | 0.0 in              |
| Length                      | 0.0 ft              |
| Number Of Steps             | 0                   |
| GVF Output Data             |                     |
| Upstream Depth              | 0.0 in              |
| Profile Description         | N/A                 |
| Profile Headloss            | 0.00 ft             |
| Average End Depth Over Rise | 0.0 %               |
| Normal Depth Over Rise      | 85.0 %              |
| Downstream Velocity         | Infinity ft/s       |
| Upstream Velocity           | Infinity ft/s       |
| Normal Depth                | 20.4 in             |
| Critical Depth              | 22.8 in             |
| Channel Slope               | 0.012 ft/ft         |
| Critical Slope              | 0.011 ft/ft         |

## Determination of Culvert Headwater and Outlet Protection

Project: **Midtown Collection at Hannah Ridge Fil. No. 3**

Basin ID: **FSD Outfall**

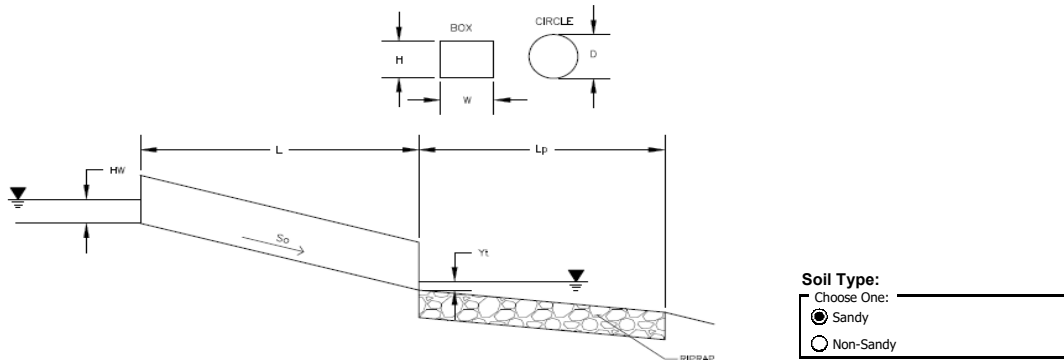

**Supercritical Flow! Using  $D_a$  to calculate protection type.**

| Design Information (Input):   |  |
|---|--|
| Design Discharge  | Q = <input style="width: 100px;" type="text" value="33.2"/> cfs                            |
| <b>Circular Culvert:</b>  |  |
| Barrel Diameter in Inches   | D = <input style="width: 100px;" type="text" value="24"/> inches                           |
| Inlet Edge Type (Choose from pull-down list)                              | 1.5 : 1 Beveled Edge <input type="button" value="v"/>                                      |
| <b>Box Culvert:</b>   | <b>OR</b>  |
| Barrel Height (Rise) in Feet  | Height (Rise) = <input style="width: 100px;" type="text"/>                                 |
| Barrel Width (Span) in Feet   | Width (Span) = <input style="width: 100px;" type="text"/>                                  |
| Inlet Edge Type (Choose from pull-down list)                              | <input type="button" value="v"/>   |
| Number of Barrels   | No = <input style="width: 100px;" type="text" value="1"/>                                  |
| Inlet Elevation   | Elev IN = <input style="width: 100px;" type="text" value="100"/> ft                        |
| Outlet Elevation <b>OR</b> Slope  | Elev OUT = <input style="width: 100px;" type="text" value="99.85"/> ft                     |
| Culvert Length  | L = <input style="width: 100px;" type="text" value="100"/> ft                              |
| Manning's Roughness   | n = <input style="width: 100px;" type="text" value="0.013"/>                               |
| Bend Loss Coefficient   | $k_b$ = <input style="width: 100px;" type="text" value="0"/>                               |
| Exit Loss Coefficient   | $k_x$ = <input style="width: 100px;" type="text" value="1"/>                               |
| Tailwater Surface Elevation   | Elev $Y_t$ = <input style="width: 100px;" type="text"/>                                    |
| Max Allowable Channel Velocity  | V = <input style="width: 100px;" type="text" value="5"/> ft/s                              |
| Required Protection (Output):   |  |
| Tailwater Surface Height  | $Y_t$ = <input style="width: 100px;" type="text" value="5.70"/> ft                         |
| Flow Area at Max Channel Velocity   | $A_t$ = <input style="width: 100px;" type="text" value="0.58"/> ft <sup>2</sup>            |
| Culvert Cross Sectional Area Available                                    | A = <input style="width: 100px;" type="text" value="1.77"/> ft <sup>2</sup>                |
| Entrance Loss Coefficient   | $k_e$ = <input style="width: 100px;" type="text" value="0.20"/>                            |
| Friction Loss Coefficient   | $k_f$ = <input style="width: 100px;" type="text" value="0.97"/>                            |
| Sum of All Losses Coefficients  | $k_s$ = <input style="width: 100px;" type="text" value="2.17"/> ft                         |
| Culvert Normal Depth  | $Y_n$ = <input style="width: 100px;" type="text" value="0.64"/> ft                         |
| Culvert Critical Depth  | $Y_c$ = <input style="width: 100px;" type="text" value="0.65"/> ft                         |
| Tailwater Depth for Design  | d = <input style="width: 100px;" type="text" value="1.07"/> ft                             |
| Adjusted Diameter <b>OR</b> Adjusted Rise                                 | $D_a$ = <input style="width: 100px;" type="text" value="1.07"/> ft                         |
| Expansion Factor  | $1/(2*\tan(\theta))$ = <input style="width: 100px;" type="text" value="6.70"/>             |
| Flow/Diameter <sup>2.5</sup> <b>OR</b> Flow/(Span * Rise <sup>1.5</sup> ) | $Q/D^{2.5}$ = <input style="width: 100px;" type="text" value="1.05"/> ft <sup>0.5</sup> /s |
| Froude Number   | Fr = <input style="width: 100px;" type="text" value="1.01"/> <b>Supercritical!</b>         |
| Tailwater/Adjusted Diameter <b>OR</b> Tailwater/Adjusted Rise             | $Y_t/D$ = <input style="width: 100px;" type="text" value="5.32"/>                          |
| Inlet Control Headwater   | $HW_i$ = <input style="width: 100px;" type="text" value="0.90"/> ft                        |
| Outlet Control Headwater  | $HW_o$ = <input style="width: 100px;" type="text" value="0.88"/> ft                        |
| <b>Design Headwater Elevation</b>   | <b>HW</b> = <input style="width: 100px;" type="text" value="6,421.65"/> ft                 |
| Headwater/Diameter <b>OR</b> Headwater/Rise Ratio                         | <b>HW/D</b> = <input style="width: 100px;" type="text" value="0.60"/>                      |
| Minimum Theoretical Riprap Size   | $d_{50}$ = <input style="width: 100px;" type="text" value="0"/> in                         |
| Nominal Riprap Size   | $d_{50}$ = <input style="width: 100px;" type="text" value="6"/> in                         |
| <b>UDFCD Riprap Type</b>  | <b>Type</b> = <input style="width: 100px;" type="text" value="VL"/>                        |
| <b>Length of Protection</b>   | $L_p$ = <input style="width: 100px;" type="text" value="5"/> ft                            |
| <b>Width of Protection</b>  | T = <input style="width: 100px;" type="text" value="3"/> ft                                |

## South Public Trapezoidal Channel

| Project Description   |                       |
|-----------------------|-----------------------|
| Friction Method       | Manning Formula       |
| Solve For             | Normal Depth          |
| Input Data            |                       |
| Roughness Coefficient | 0.045                 |
| Channel Slope         | 0.007 ft/ft           |
| Left Side Slope       | 3.000 H:V             |
| Right Side Slope      | 3.000 H:V             |
| Bottom Width          | 20.00 ft              |
| Discharge             | 1,076.00 cfs          |
| Results               |                       |
| Normal Depth          | 60.7 in               |
| Flow Area             | 178.0 ft <sup>2</sup> |
| Wetted Perimeter      | 52.0 ft               |
| Hydraulic Radius      | 41.1 in               |
| Top Width             | 50.35 ft              |
| Critical Depth        | 44.4 in               |
| Critical Slope        | 0.022 ft/ft           |
| Velocity              | 6.05 ft/s             |
| Velocity Head         | 0.57 ft               |
| Specific Energy       | 5.63 ft               |
| Froude Number         | 0.567                 |
| Flow Type             | Subcritical           |
| GVF Input Data        |                       |
| Downstream Depth      | 0.0 in                |
| Length                | 0.0 ft                |
| Number Of Steps       | 0                     |
| GVF Output Data       |                       |
| Upstream Depth        | 0.0 in                |
| Profile Description   | N/A                   |
| Profile Headloss      | 0.00 ft               |
| Downstream Velocity   | 0.00 ft/s             |
| Upstream Velocity     | 0.00 ft/s             |
| Normal Depth          | 60.7 in               |
| Critical Depth        | 44.4 in               |
| Channel Slope         | 0.007 ft/ft           |
| Critical Slope        | 0.022 ft/ft           |

6' x 12' PUBLIC DUAL BOX CULVERT

$Q_{100} = 1076 \div 24 = 45 \text{ cfs/ft}$

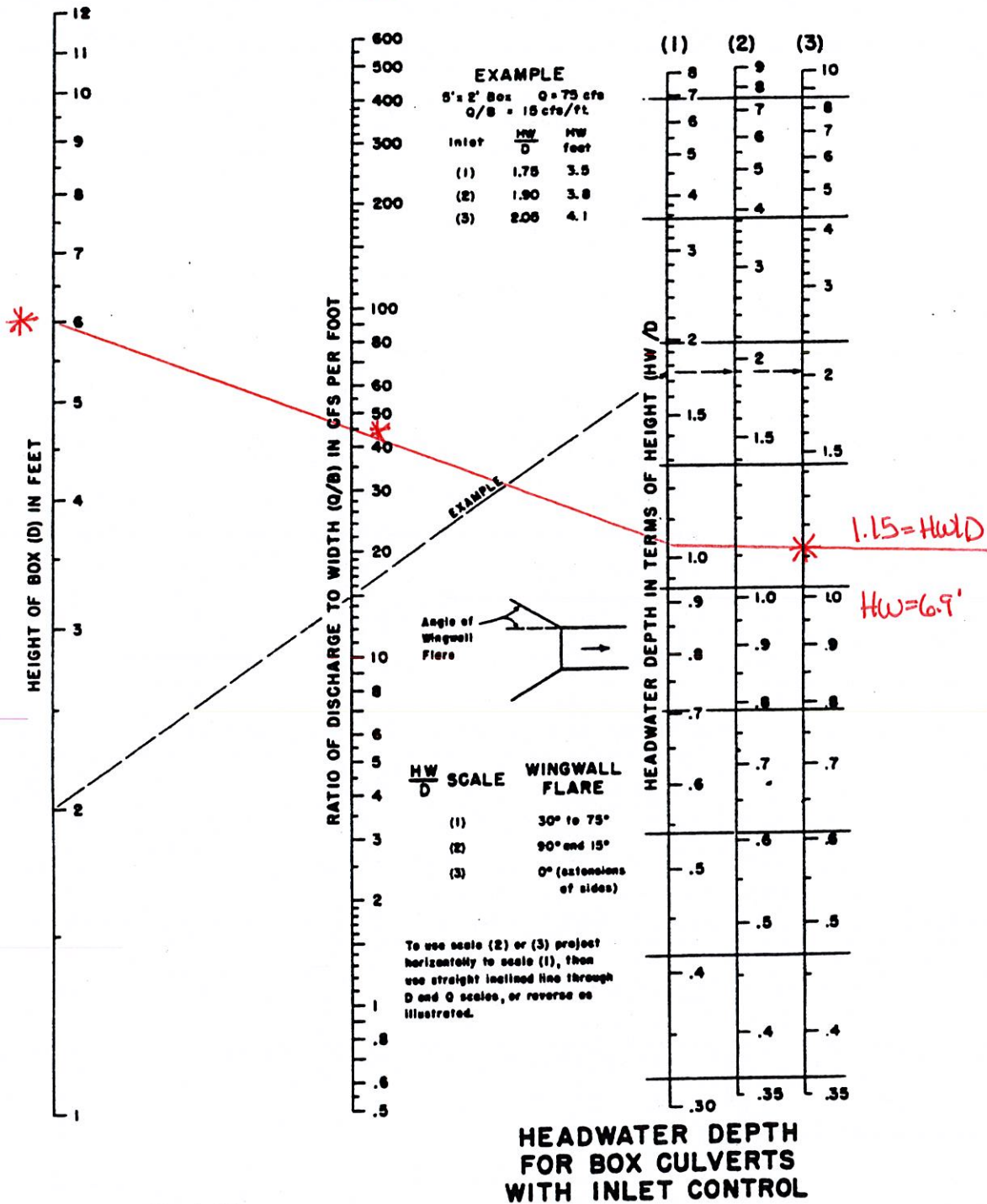

BUREAU OF PUBLIC ROADS JAN. 1963



HDR Infrastructure, Inc.  
A Centerra Company

The City of Colorado Springs / El Paso County  
Drainage Criteria Manual

Date

OCT. 1987

Figure

9-30

**SWQ / FULL SPECTRUM  
DETENTION CALCULATIONS**





# DETENTION BASIN STAGE-STORAGE TABLE BUILDER

*MHFD-Detention, Version 4.04 (February 2021)*

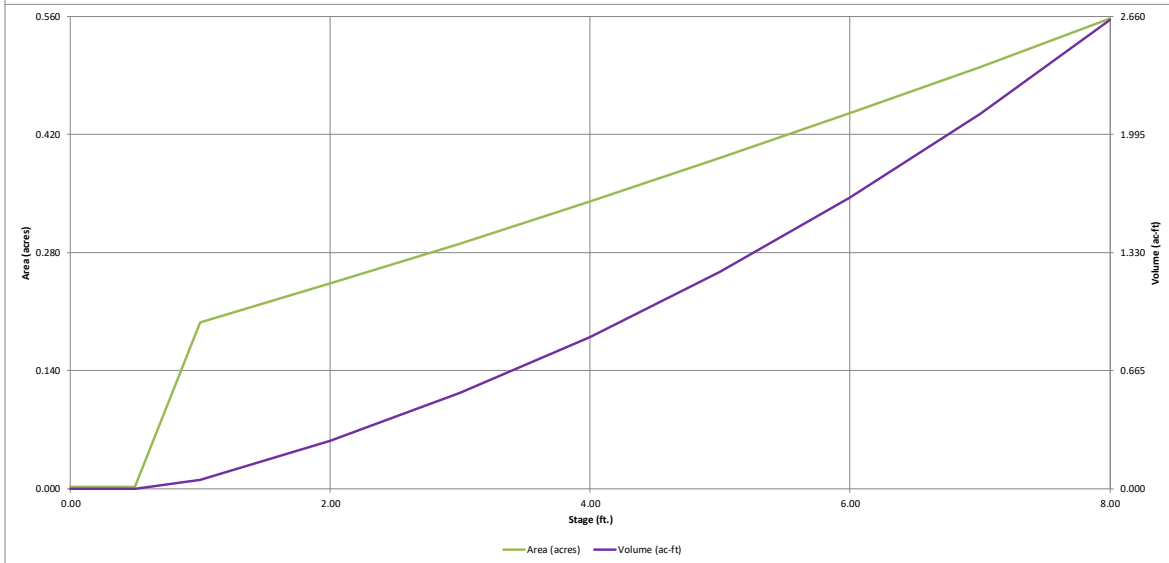
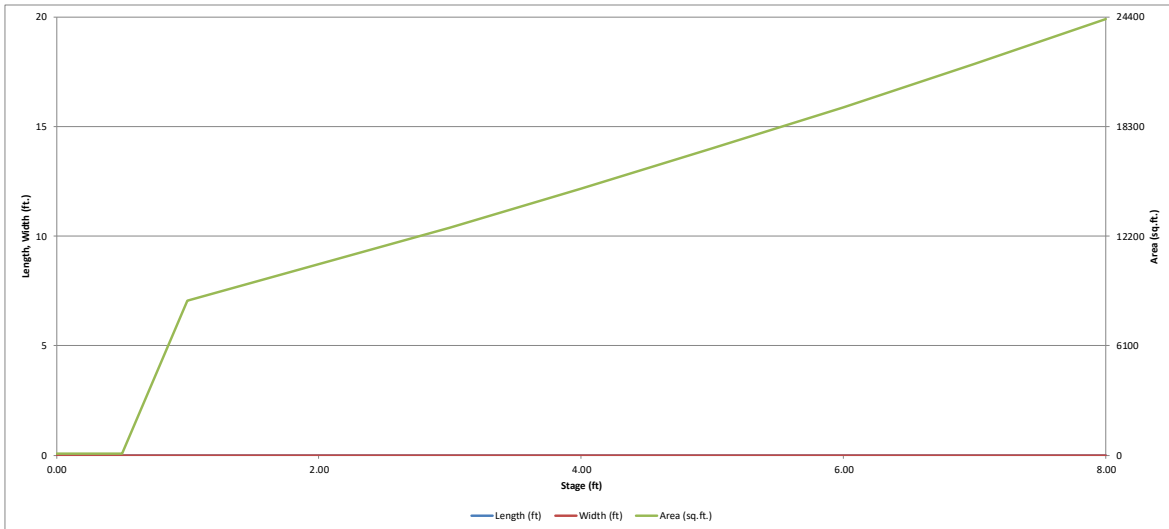

# DETENTION BASIN OUTLET STRUCTURE DESIGN

*MHFD-Detention, Version 4.04 (February 2021)*

**Project: MIDTOWN AT HANNAH RIDGE FILING NO. 3**

**Basin ID: POND**

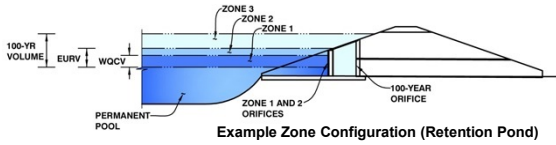

|                          | Estimated Stage (ft) | Estimated Volume (ac-ft) | Outlet Type          |
|--------------------------|----------------------|--------------------------|----------------------|
| Zone 1 (WQCV)            | 2.24                 | 0.331                    | Orifice Plate        |
| Zone 2 (EURV)            | 4.44                 | 0.677                    | Orifice Plate        |
| Zone 3 (100-year)        | 6.07                 | 0.661                    | Weir&Pipe (Restrict) |
| <b>Total (all zones)</b> |                      | <b>1.669</b>             |                      |

User Input: Orifice at Underdrain Outlet (typically used to drain WQCV in a Filtration BMP)

|                                   |     |  |
|-----------------------------------|-----|--|
| Underdrain Orifice Invert Depth = | N/A | ft (distance below the filtration media surface) |
| Underdrain Orifice Diameter =     | N/A | inches   |

|                                      |     |                 |
|--------------------------------------|-----|-----------------|
| Calculated Parameters for Underdrain |     |                 |
| Underdrain Orifice Area =            | N/A | ft <sup>2</sup> |
| Underdrain Orifice Centroid =        | N/A | feet            |

User Input: Orifice Plate with one or more orifices or Elliptical Slot Weir (typically used to drain WQCV and/or EURV in a sedimentation BMP)

|  |       |   |
|--|-------|---|
| Invert of Lowest Orifice =                 | 0.00  | ft (relative to basin bottom at Stage = 0 ft) |
| Depth at top of Zone using Orifice Plate = | 4.60  | ft (relative to basin bottom at Stage = 0 ft) |
| Orifice Plate: Orifice Vertical Spacing =  | 17.80 | inches  |
| Orifice Plate: Orifice Area per Row =      | 2.18  | sq. inches (diameter = 1-5/8 inches)          |

|                                 |           |                 |
|---------------------------------|-----------|-----------------|
| Calculated Parameters for Plate |           |                 |
| WQ Orifice Area per Row =       | 1.514E-02 | ft <sup>2</sup> |
| Elliptical Half-Width =         | N/A       | feet            |
| Elliptical Slot Centroid =      | N/A       | feet            |
| Elliptical Slot Area =          | N/A       | ft <sup>2</sup> |

User Input: Stage and Total Area of Each Orifice Row (numbered from lowest to highest)

|                                | Row 1 (required) | Row 2 (optional) | Row 3 (optional) | Row 4 (optional) | Row 5 (optional) | Row 6 (optional) | Row 7 (optional) | Row 8 (optional) |
|--------------------------------|------------------|------------------|------------------|------------------|------------------|------------------|------------------|------------------|
| Stage of Orifice Centroid (ft) | 0.00             | 1.53             | 3.07             |                  |                  |                  |                  |                  |
| Orifice Area (sq. inches)      | 2.18             | 2.18             | 2.18             |                  |                  |                  |                  |                  |

|                                | Row 9 (optional) | Row 10 (optional) | Row 11 (optional) | Row 12 (optional) | Row 13 (optional) | Row 14 (optional) | Row 15 (optional) | Row 16 (optional) |
|--------------------------------|------------------|-------------------|-------------------|-------------------|-------------------|-------------------|-------------------|-------------------|
| Stage of Orifice Centroid (ft) |                  |                   |                   |                   |                   |                   |                   |                   |
| Orifice Area (sq. inches)      |                  |                   |                   |                   |                   |                   |                   |                   |

User Input: Vertical Orifice (Circular or Rectangular)

|   |              |              |   |
|---|--------------|--------------|---|
|   | Not Selected | Not Selected |   |
| Invert of Vertical Orifice =                  | N/A          | N/A          | ft (relative to basin bottom at Stage = 0 ft) |
| Depth at top of Zone using Vertical Orifice = | N/A          | N/A          | ft (relative to basin bottom at Stage = 0 ft) |
| Vertical Orifice Diameter =                   | N/A          | N/A          | inches  |

|  |     |                 |
|--|-----|-----------------|
| Calculated Parameters for Vertical Orifice |     |                 |
| Vertical Orifice Area =                    | N/A | ft <sup>2</sup> |
| Vertical Orifice Centroid =                | N/A | feet            |

User Input: Overflow Weir (Dropbox with Flat or Sloped Grate and Outlet Pipe OR Rectangular/Trapezoidal Weir (and No Outlet Pipe))

|                                       |              |              |   |
|---------------------------------------|--------------|--------------|---|
|                                       | Zone 3 Weir  | Not Selected |   |
| Overflow Weir Front Edge Height, Ho = | 4.60         | N/A          | ft (relative to basin bottom at Stage = 0 ft) |
| Overflow Weir Front Edge Length =     | 6.00         | N/A          | feet  |
| Overflow Weir Grate Slope =           | 3.00         | N/A          | H:V   |
| Horiz. Length of Weir Sides =         | 5.00         | N/A          | feet  |
| Overflow Grate Type =                 | Type C Grate | N/A          |   |
| Debris Clogging % =                   | 50%          | N/A          | %   |

|  |       |                 |
|--|-------|-----------------|
| Calculated Parameters for Overflow Weir      |       |                 |
| Height of Grate Upper Edge, H <sub>g</sub> = | 6.27  | ft              |
| Overflow Weir Slope Length =                 | 5.27  | feet            |
| Grate Open Area / 100-yr Orifice Area =      | 12.45 | N/A             |
| Overflow Grate Open Area w/o Debris =        | 22.01 | ft <sup>2</sup> |
| Overflow Grate Open Area w/ Debris =         | 11.00 | ft <sup>2</sup> |

User Input: Outlet Pipe w/ Flow Restriction Plate (Circular Orifice, Restrictor Plate, or Rectangular Orifice)

|   |                   |              |  |
|---|-------------------|--------------|--|
|   | Zone 3 Restrictor | Not Selected |  |
| Depth to Invert of Outlet Pipe =            | 2.50              | N/A          | ft (distance below basin bottom at Stage = 0 ft) |
| Outlet Pipe Diameter =                      | 18.00             | N/A          | inches   |
| Restrictor Plate Height Above Pipe Invert = | 18.00             | N/A          | inches   |

|   |      |                 |
|---|------|-----------------|
| Calculated Parameters for Outlet Pipe w/ Flow Restriction Plate |      |                 |
| Outlet Orifice Area =   | 1.77 | ft <sup>2</sup> |
| Outlet Orifice Centroid =                                       | 0.75 | feet            |
| Half-Central Angle of Restrictor Plate on Pipe =                | 3.14 | radians         |

User Input: Emergency Spillway (Rectangular or Trapezoidal)

|                                     |       |   |
|-------------------------------------|-------|---|
| Spillway Invert Stage =             | 6.50  | ft (relative to basin bottom at Stage = 0 ft) |
| Spillway Crest Length =             | 65.00 | feet  |
| Spillway End Slopes =               | 4.00  | H:V   |
| Freeboard above Max Water Surface = | 1.00  | feet  |

|                                    |      |         |
|------------------------------------|------|---------|
| Calculated Parameters for Spillway |      |         |
| Spillway Design Flow Depth =       | 0.37 | feet    |
| Stage at Top of Freeboard =        | 7.87 | feet    |
| Basin Area at Top of Freeboard =   | 0.55 | acres   |
| Basin Volume at Top of Freeboard = | 2.57 | acre-ft |

## Routed Hydrograph Results

*The user can override the default CUHP hydrographs and runoff volumes by entering new values in the Inflow Hydrographs table (Columns W through AF).*

|   | WQCV  | EURV  | 2 Year | 5 Year | 10 Year         | 25 Year         | 50 Year         | 100 Year        | 500 Year |
|---|-------|-------|--------|--------|-----------------|-----------------|-----------------|-----------------|----------|
| Design Storm Return Period =                    | N/A   | N/A   | 1.19   | 1.50   | 1.75            | 2.00            | 2.25            | 2.52            | 3.00     |
| One-Hour Rainfall Depth (in) =                  | N/A   | N/A   | 0.740  | 0.992  | 1.191           | 1.544           | 1.888           | 2.334           | 3.067    |
| CUHP Runoff Volume (acre-ft) =                  | N/A   | N/A   | 0.740  | 0.992  | 1.191           | 1.544           | 1.888           | 2.334           | 3.067    |
| Inflow Hydrograph Volume (acre-ft) =            | N/A   | N/A   | 0.2    | 0.4    | 0.6             | 5.1             | 10.1            | 16.6            | 26.4     |
| CUHP Predevelopment Peak Q (cfs) =              | N/A   | N/A   | N/A    | N/A    | N/A             | N/A             | N/A             | N/A             | N/A      |
| OPTIONAL Override Predevelopment Peak Q (cfs) = | N/A   | N/A   | N/A    | N/A    | N/A             | N/A             | N/A             | N/A             | N/A      |
| Predevelopment Unit Peak Flow, q (cfs/acre) =   | N/A   | N/A   | 0.01   | 0.02   | 0.03            | 0.24            | 0.48            | 0.79            | 1.25     |
| Peak Inflow Q (cfs) =                           | N/A   | N/A   | 12.4   | 16.9   | 20.2            | 28.5            | 35.9            | 45.9            | 60.3     |
| Peak Outflow Q (cfs) =                          | 0.2   | 0.4   | 0.3    | 0.3    | 0.6             | 2.4             | 5.2             | 10.5            | 27.5     |
| Ratio Peak Outflow to Predevelopment Q =        | N/A   | N/A   | N/A    | 0.8    | 1.0             | 0.5             | 0.5             | 0.6             | 1.0      |
| Structure Controlling Flow =                    | Plate | Plate | Plate  | Plate  | Overflow Weir 1 | Overflow Weir 1 | Overflow Weir 1 | Overflow Weir 1 | Spillway |
| Max Velocity through Grate 1 (fps) =            | N/A   | N/A   | N/A    | N/A    | 0.0             | 0.1             | 0.2             | 0.5             | 0.7      |
| Max Velocity through Grate 2 (fps) =            | N/A   | N/A   | N/A    | N/A    | N/A             | N/A             | N/A             | N/A             | N/A      |
| Time to Drain 97% of Inflow Volume (hours) =    | 39    | 67    | 59     | 67     | 72              | 72              | 71              | 69              | 65       |
| Time to Drain 99% of Inflow Volume (hours) =    | 40    | 71    | 62     | 71     | 76              | 77              | 77              | 76              | 75       |
| Maximum Ponding Depth (ft) =                    | 2.24  | 4.44  | 3.52   | 4.24   | 4.75            | 5.27            | 5.68            | 6.22            | 6.65     |
| Area at Maximum Ponding Depth (acres) =         | 0.26  | 0.36  | 0.32   | 0.35   | 0.38            | 0.41            | 0.43            | 0.46            | 0.48     |
| Maximum Volume Stored (acre-ft) =               | 0.331 | 1.009 | 0.697  | 0.938  | 1.125           | 1.325           | 1.500           | 1.739           | 1.940    |

# DETENTION BASIN OUTLET STRUCTURE DESIGN

*MHFD-Detention, Version 4.04 (February 2021)*

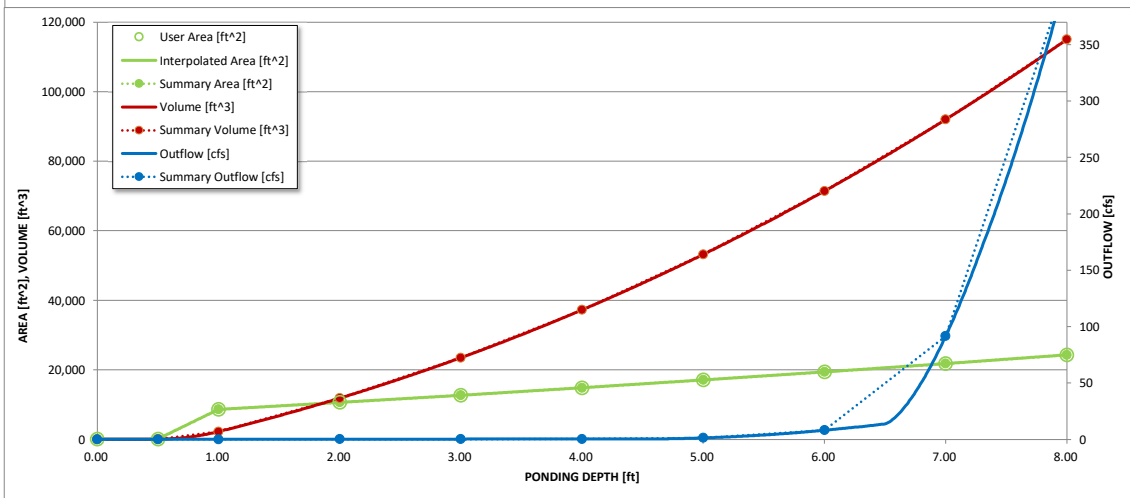
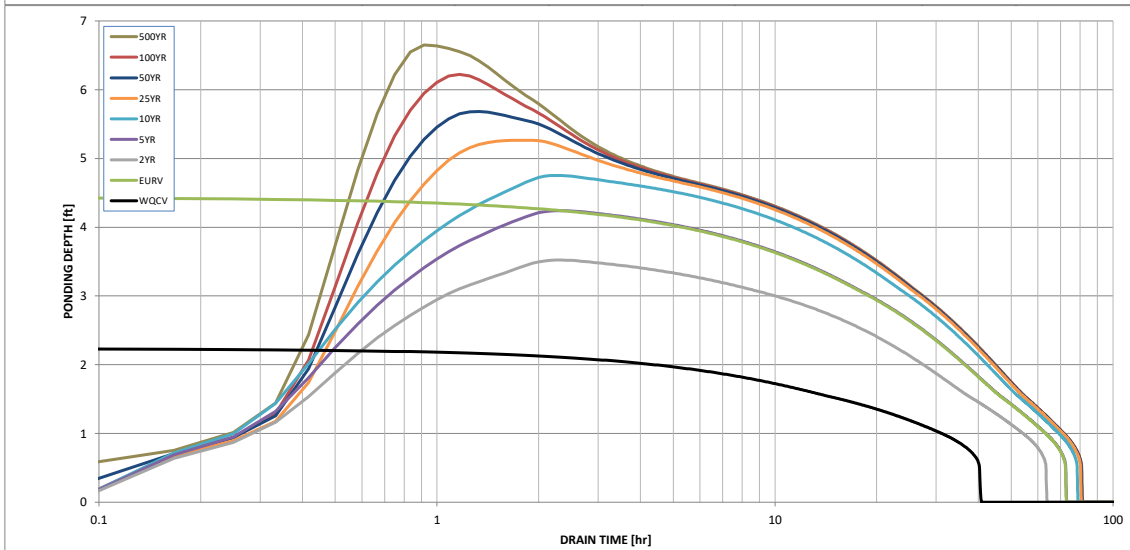
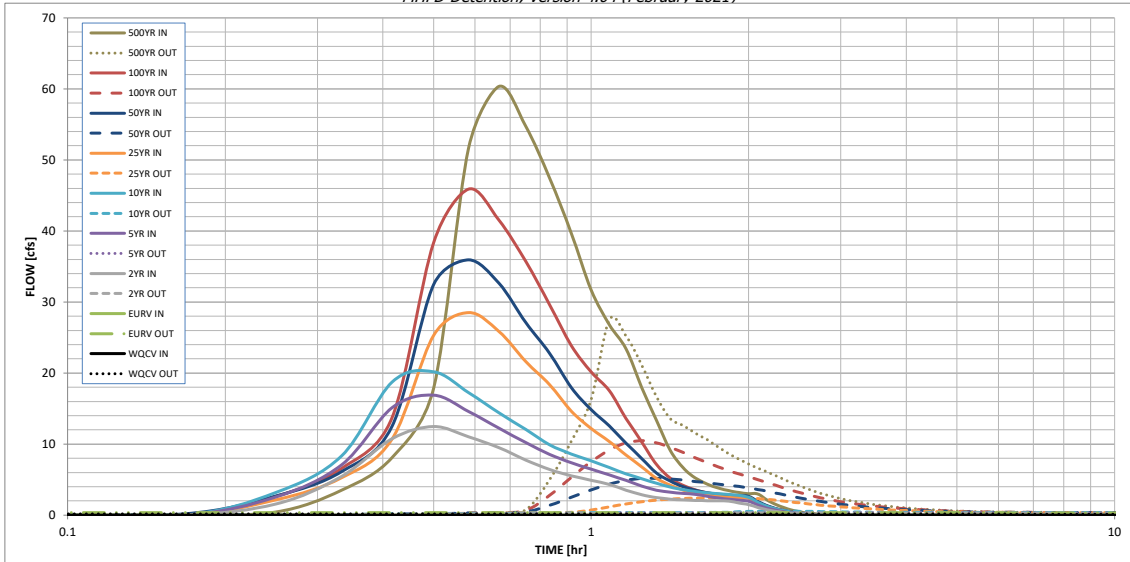

| S-A-V-D Chart Axis Override | X-axis | Left Y-Axis | Right Y-Axis |
|-----------------------------|--------|-------------|--------------|
| minimum bound               |        |             |              |
| maximum bound               |        |             |              |

# DETENTION BASIN OUTLET STRUCTURE DESIGN

Outflow Hydrograph Workbook Filename: \_\_\_\_\_

**Inflow Hydrographs**

The user can override the calculated inflow hydrographs from this workbook with inflow hydrographs developed in a separate program.

| Time Interval | SOURCE  | CUHP       | CUHP       | CUHP         | CUHP         | CUHP          | CUHP          | CUHP          | CUHP           | CUHP           |
|---------------|---------|------------|------------|--------------|--------------|---------------|---------------|---------------|----------------|----------------|
|               | TIME    | WQCV [cfs] | EURV [cfs] | 2 Year [cfs] | 5 Year [cfs] | 10 Year [cfs] | 25 Year [cfs] | 50 Year [cfs] | 100 Year [cfs] | 500 Year [cfs] |
| 5.00 min      | 0:00:00 | 0.00       | 0.00       | 0.00         | 0.00         | 0.00          | 0.00          | 0.00          | 0.00           | 0.00           |
|               | 0:05:00 | 0.00       | 0.00       | 0.00         | 0.00         | 0.00          | 0.00          | 0.00          | 0.00           | 0.00           |
|               | 0:10:00 | 0.00       | 0.00       | 0.00         | 0.00         | 0.00          | 0.00          | 0.18          | 0.02           | 0.46           |
|               | 0:15:00 | 0.00       | 0.00       | 1.57         | 2.56         | 3.19          | 2.15          | 2.67          | 2.64           | 3.49           |
|               | 0:20:00 | 0.00       | 0.00       | 5.43         | 7.06         | 8.32          | 5.25          | 6.11          | 6.58           | 8.11           |
|               | 0:25:00 | 0.00       | 0.00       | 10.74        | 15.10        | 18.74         | 10.70         | 12.52         | 13.74          | 17.85          |
|               | 0:30:00 | 0.00       | 0.00       | 12.45        | 16.87        | 20.18         | 25.31         | 32.46         | 38.39          | 51.65          |
|               | 0:35:00 | 0.00       | 0.00       | 11.01        | 14.57        | 17.24         | 28.52         | 35.92         | 45.89          | 60.33          |
|               | 0:40:00 | 0.00       | 0.00       | 9.48         | 12.25        | 14.41         | 25.87         | 32.64         | 41.52          | 54.72          |
|               | 0:45:00 | 0.00       | 0.00       | 7.75         | 10.20        | 12.04         | 21.62         | 27.09         | 35.70          | 47.45          |
|               | 0:50:00 | 0.00       | 0.00       | 6.41         | 8.56         | 9.90          | 18.37         | 22.79         | 29.64          | 39.68          |
|               | 0:55:00 | 0.00       | 0.00       | 5.54         | 7.36         | 8.60          | 14.64         | 17.94         | 23.85          | 31.71          |
|               | 1:00:00 | 0.00       | 0.00       | 4.91         | 6.47         | 7.63          | 12.20         | 14.84         | 20.16          | 26.81          |
|               | 1:05:00 | 0.00       | 0.00       | 4.32         | 5.65         | 6.68          | 10.37         | 12.54         | 17.52          | 23.42          |
|               | 1:10:00 | 0.00       | 0.00       | 3.52         | 4.89         | 5.81          | 8.46          | 10.12         | 13.61          | 17.97          |
|               | 1:15:00 | 0.00       | 0.00       | 2.87         | 4.09         | 5.11          | 6.79          | 7.97          | 10.30          | 13.36          |
|               | 1:20:00 | 0.00       | 0.00       | 2.46         | 3.52         | 4.50          | 5.17          | 5.94          | 7.13           | 9.12           |
|               | 1:25:00 | 0.00       | 0.00       | 2.25         | 3.22         | 3.95          | 4.21          | 4.79          | 5.23           | 6.63           |
|               | 1:30:00 | 0.00       | 0.00       | 2.14         | 3.05         | 3.58          | 3.52          | 3.98          | 4.17           | 5.22           |
|               | 1:35:00 | 0.00       | 0.00       | 2.08         | 2.94         | 3.32          | 3.10          | 3.49          | 3.55           | 4.37           |
|               | 1:40:00 | 0.00       | 0.00       | 2.04         | 2.63         | 3.13          | 2.81          | 3.16          | 3.14           | 3.81           |
|               | 1:45:00 | 0.00       | 0.00       | 2.00         | 2.40         | 3.00          | 2.63          | 2.96          | 2.86           | 3.45           |
|               | 1:50:00 | 0.00       | 0.00       | 1.98         | 2.23         | 2.91          | 2.50          | 2.81          | 2.66           | 3.18           |
|               | 1:55:00 | 0.00       | 0.00       | 1.70         | 2.10         | 2.76          | 2.42          | 2.71          | 2.55           | 3.02           |
|               | 2:00:00 | 0.00       | 0.00       | 1.50         | 1.95         | 2.49          | 2.37          | 2.66          | 2.51           | 2.98           |
|               | 2:05:00 | 0.00       | 0.00       | 1.08         | 1.41         | 1.79          | 1.70          | 1.91          | 1.80           | 2.14           |
|               | 2:10:00 | 0.00       | 0.00       | 0.77         | 1.00         | 1.26          | 1.20          | 1.35          | 1.28           | 1.51           |
|               | 2:15:00 | 0.00       | 0.00       | 0.53         | 0.70         | 0.88          | 0.84          | 0.94          | 0.90           | 1.06           |
|               | 2:20:00 | 0.00       | 0.00       | 0.37         | 0.47         | 0.60          | 0.58          | 0.64          | 0.61           | 0.72           |
|               | 2:25:00 | 0.00       | 0.00       | 0.24         | 0.31         | 0.40          | 0.38          | 0.43          | 0.41           | 0.48           |
|               | 2:30:00 | 0.00       | 0.00       | 0.16         | 0.21         | 0.27          | 0.26          | 0.29          | 0.27           | 0.32           |
|               | 2:35:00 | 0.00       | 0.00       | 0.09         | 0.13         | 0.16          | 0.16          | 0.18          | 0.16           | 0.19           |
|               | 2:40:00 | 0.00       | 0.00       | 0.04         | 0.07         | 0.08          | 0.08          | 0.09          | 0.08           | 0.09           |
|               | 2:45:00 | 0.00       | 0.00       | 0.02         | 0.03         | 0.03          | 0.03          | 0.03          | 0.03           | 0.03           |
|               | 2:50:00 | 0.00       | 0.00       | 0.00         | 0.01         | 0.00          | 0.00          | 0.00          | 0.00           | 0.00           |
|               | 2:55:00 | 0.00       | 0.00       | 0.00         | 0.00         | 0.00          | 0.00          | 0.00          | 0.00           | 0.00           |
|               | 3:00:00 | 0.00       | 0.00       | 0.00         | 0.00         | 0.00          | 0.00          | 0.00          | 0.00           | 0.00           |
|               | 3:05:00 | 0.00       | 0.00       | 0.00         | 0.00         | 0.00          | 0.00          | 0.00          | 0.00           | 0.00           |
|               | 3:10:00 | 0.00       | 0.00       | 0.00         | 0.00         | 0.00          | 0.00          | 0.00          | 0.00           | 0.00           |
|               | 3:15:00 | 0.00       | 0.00       | 0.00         | 0.00         | 0.00          | 0.00          | 0.00          | 0.00           | 0.00           |
|               | 3:20:00 | 0.00       | 0.00       | 0.00         | 0.00         | 0.00          | 0.00          | 0.00          | 0.00           | 0.00           |
|               | 3:25:00 | 0.00       | 0.00       | 0.00         | 0.00         | 0.00          | 0.00          | 0.00          | 0.00           | 0.00           |
|               | 3:30:00 | 0.00       | 0.00       | 0.00         | 0.00         | 0.00          | 0.00          | 0.00          | 0.00           | 0.00           |
|               | 3:35:00 | 0.00       | 0.00       | 0.00         | 0.00         | 0.00          | 0.00          | 0.00          | 0.00           | 0.00           |
|               | 3:40:00 | 0.00       | 0.00       | 0.00         | 0.00         | 0.00          | 0.00          | 0.00          | 0.00           | 0.00           |
|               | 3:45:00 | 0.00       | 0.00       | 0.00         | 0.00         | 0.00          | 0.00          | 0.00          | 0.00           | 0.00           |
|               | 3:50:00 | 0.00       | 0.00       | 0.00         | 0.00         | 0.00          | 0.00          | 0.00          | 0.00           | 0.00           |
|               | 3:55:00 | 0.00       | 0.00       | 0.00         | 0.00         | 0.00          | 0.00          | 0.00          | 0.00           | 0.00           |
|               | 4:00:00 | 0.00       | 0.00       | 0.00         | 0.00         | 0.00          | 0.00          | 0.00          | 0.00           | 0.00           |
|               | 4:05:00 | 0.00       | 0.00       | 0.00         | 0.00         | 0.00          | 0.00          | 0.00          | 0.00           | 0.00           |
|               | 4:10:00 | 0.00       | 0.00       | 0.00         | 0.00         | 0.00          | 0.00          | 0.00          | 0.00           | 0.00           |
|               | 4:15:00 | 0.00       | 0.00       | 0.00         | 0.00         | 0.00          | 0.00          | 0.00          | 0.00           | 0.00           |
|               | 4:20:00 | 0.00       | 0.00       | 0.00         | 0.00         | 0.00          | 0.00          | 0.00          | 0.00           | 0.00           |
|               | 4:25:00 | 0.00       | 0.00       | 0.00         | 0.00         | 0.00          | 0.00          | 0.00          | 0.00           | 0.00           |
|               | 4:30:00 | 0.00       | 0.00       | 0.00         | 0.00         | 0.00          | 0.00          | 0.00          | 0.00           | 0.00           |
|               | 4:35:00 | 0.00       | 0.00       | 0.00         | 0.00         | 0.00          | 0.00          | 0.00          | 0.00           | 0.00           |
|               | 4:40:00 | 0.00       | 0.00       | 0.00         | 0.00         | 0.00          | 0.00          | 0.00          | 0.00           | 0.00           |
|               | 4:45:00 | 0.00       | 0.00       | 0.00         | 0.00         | 0.00          | 0.00          | 0.00          | 0.00           | 0.00           |
|               | 4:50:00 | 0.00       | 0.00       | 0.00         | 0.00         | 0.00          | 0.00          | 0.00          | 0.00           | 0.00           |
|               | 4:55:00 | 0.00       | 0.00       | 0.00         | 0.00         | 0.00          | 0.00          | 0.00          | 0.00           | 0.00           |
|               | 5:00:00 | 0.00       | 0.00       | 0.00         | 0.00         | 0.00          | 0.00          | 0.00          | 0.00           | 0.00           |
|               | 5:05:00 | 0.00       | 0.00       | 0.00         | 0.00         | 0.00          | 0.00          | 0.00          | 0.00           | 0.00           |
|               | 5:10:00 | 0.00       | 0.00       | 0.00         | 0.00         | 0.00          | 0.00          | 0.00          | 0.00           | 0.00           |
|               | 5:15:00 | 0.00       | 0.00       | 0.00         | 0.00         | 0.00          | 0.00          | 0.00          | 0.00           | 0.00           |
|               | 5:20:00 | 0.00       | 0.00       | 0.00         | 0.00         | 0.00          | 0.00          | 0.00          | 0.00           | 0.00           |
|               | 5:25:00 | 0.00       | 0.00       | 0.00         | 0.00         | 0.00          | 0.00          | 0.00          | 0.00           | 0.00           |
|               | 5:30:00 | 0.00       | 0.00       | 0.00         | 0.00         | 0.00          | 0.00          | 0.00          | 0.00           | 0.00           |
|               | 5:35:00 | 0.00       | 0.00       | 0.00         | 0.00         | 0.00          | 0.00          | 0.00          | 0.00           | 0.00           |
|               | 5:40:00 | 0.00       | 0.00       | 0.00         | 0.00         | 0.00          | 0.00          | 0.00          | 0.00           | 0.00           |
|               | 5:45:00 | 0.00       | 0.00       | 0.00         | 0.00         | 0.00          | 0.00          | 0.00          | 0.00           | 0.00           |
|               | 5:50:00 | 0.00       | 0.00       | 0.00         | 0.00         | 0.00          | 0.00          | 0.00          | 0.00           | 0.00           |
|               | 5:55:00 | 0.00       | 0.00       | 0.00         | 0.00         | 0.00          | 0.00          | 0.00          | 0.00           | 0.00           |
|               | 6:00:00 | 0.00       | 0.00       | 0.00         | 0.00         | 0.00          | 0.00          | 0.00          | 0.00           | 0.00           |



## Design Procedure Form: Extended Detention Basin (EDB)

UD-BMP (Version 3.06, November 2016)

Sheet 1 of 4

**Designer:** \_\_\_\_\_  
**Company:** Classic Consulting Engineers  
**Date:** February 18, 2022  
**Project:** Midtown Collection at Hannah Ridge Filing No. 3  
**Location:** EDB Forebay 1

|   |  |
|---|--|
| <p>1. Basin Storage Volume</p> <p>A) Effective Imperviousness of Tributary Area, <math>I_a</math></p> <p>B) Tributary Area's Imperviousness Ratio (<math>i = I_a / 100</math>)</p> <p>C) Contributing Watershed Area</p> <p>D) For Watersheds Outside of the Denver Region, Depth of Average Runoff Producing Storm</p> <p>E) Design Concept<br/>(Select EURV when also designing for flood control)</p> <p>F) Design Volume (WQCV) Based on 40-hour Drain Time<br/>(<math>V_{DESIGN} = (1.0 * (0.91 * I_a^3 - 1.19 * I_a^2 + 0.78 * I_a) / 12 * Area)</math>)</p> <p>G) For Watersheds Outside of the Denver Region, Water Quality Capture Volume (WQCV) Design Volume<br/>(<math>V_{WQCV\ OTHER} = (d_b * (V_{DESIGN} / 0.43))</math>)</p> <p>H) User Input of Water Quality Capture Volume (WQCV) Design Volume<br/>(Only if a different WQCV Design Volume is desired)</p> <p>I) Predominant Watershed NRCS Soil Group</p> <p>J) Excess Urban Runoff Volume (EURV) Design Volume<br/>                     For HSG A: <math>EURV_A = 1.68 * i^{1.28}</math><br/>                     For HSG B: <math>EURV_B = 1.36 * i^{1.08}</math><br/>                     For HSG C/D: <math>EURV_{C/D} = 1.20 * i^{1.08}</math> </p> | <p><math>I_a =</math> <u>43.2</u> %</p> <p><math>i =</math> <u>0.432</u></p> <p>Area = <u>21.080</u> ac</p> <p><math>d_b =</math> <u>0.43</u> in</p> <div style="border: 1px solid black; padding: 5px; margin-bottom: 10px;"> <p>Choose One</p> <p><input type="radio"/> Water Quality Capture Volume (WQCV)</p> <p><input checked="" type="radio"/> Excess Urban Runoff Volume (EURV)</p> </div> <p><math>V_{DESIGN} =</math> <u>0.331</u> ac-ft</p> <p><math>V_{DESIGN\ OTHER} =</math> <u>0.331</u> ac-ft</p> <p><math>V_{DESIGN\ USER} =</math> _____ ac-ft</p> <div style="border: 1px solid black; padding: 5px; margin-bottom: 10px;"> <p>Choose One</p> <p><input checked="" type="radio"/> A</p> <p><input type="radio"/> B</p> <p><input type="radio"/> C / D</p> </div> <p>EURV = <u>1.008</u> ac-ft</p> |
| <p>2. Basin Shape: Length to Width Ratio<br/>(A basin length to width ratio of at least 2:1 will improve TSS reduction.)</p>  | <p>L : W = <u>2.0</u> : 1</p>  |
| <p>3. Basin Side Slopes</p> <p>A) Basin Maximum Side Slopes<br/>(Horizontal distance per unit vertical, 4:1 or flatter preferred)</p>   | <p>Z = <u>3.00</u> ft / ft</p> <p style="color: red; font-weight: bold;">DIFFICULT TO MAINTAIN, INCREASE WHERE POSSIBLE</p>  |
| <p>4. Inlet</p> <p>A) Describe means of providing energy dissipation at concentrated inflow locations:</p>  | <p>_____</p> <p>_____</p> <p>_____</p> <p>_____</p>  |

**Design Procedure Form: Extended Detention Basin (EDB)**

**Designer:** \_\_\_\_\_  
**Company:** Classic Consulting Engineers  
**Date:** February 18, 2022  
**Project:** Midtown Collection at Hannah Ridge Filing No. 3  
**Location:** EDB Forebay 1

|   |   |
|---|---|
| <p>5. Forebay</p> <p>A) Minimum Forebay Volume<br/>(<math>V_{FMIN} =</math> <u>3%</u> of the WQCV)</p> <p>B) Actual Forebay Volume</p> <p>C) Forebay Depth<br/>(<math>D_F =</math> <u>18</u> inch maximum)</p> <p>D) Forebay Discharge</p> <p style="margin-left: 40px;">i) Undetained 100-year Peak Discharge</p> <p style="margin-left: 40px;">ii) Forebay Discharge Design Flow<br/>(<math>Q_F = 0.02 * Q_{100}</math>)</p> <p>E) Forebay Discharge Design</p><br><p>F) Discharge Pipe Size (minimum 8-inches)</p> <p>G) Rectangular Notch Width</p> | <p><math>V_{FMIN} =</math> <u>0.010</u> ac-ft</p> <p><math>V_F =</math> <u>0.012</u> ac-ft</p> <p><math>D_F =</math> <u>12.0</u> in</p> <p><math>Q_{100} =</math> <u>69.50</u> cfs</p> <p><math>Q_F =</math> <u>1.39</u> cfs</p> <div style="border: 1px solid black; padding: 2px; margin: 5px 0;">             Choose One<br/> <input type="radio"/> Berm With Pipe<br/> <input checked="" type="radio"/> Wall with Rect. Notch<br/> <input type="radio"/> Wall with V-Notch Weir         </div> <p style="color: blue; margin-left: 100px;">(flow too small for berm w/ pipe)</p> <p>Calculated <math>D_p =</math> <u>          </u> in</p> <p>Calculated <math>W_N =</math> <u>7.4</u> in</p> |
| <p>6. Trickle Channel</p> <p>A) Type of Trickle Channel</p><br><p>F) Slope of Trickle Channel</p>   | <div style="border: 1px solid black; padding: 2px; margin: 5px 0;">             Choose One<br/> <input checked="" type="radio"/> Concrete<br/> <input type="radio"/> Soft Bottom         </div> <p><math>S =</math> <u>0.0100</u> ft / ft</p>   |
| <p>7. Micropool and Outlet Structure</p> <p>A) Depth of Micropool (2.5-feet minimum)</p> <p>B) Surface Area of Micropool (10 ft<sup>2</sup> minimum)</p> <p>C) Outlet Type</p><br><p>D) Smallest Dimension of Orifice Opening Based on Hydrograph Routing<br/>(Use UD-Detention)</p> <p>E) Total Outlet Area</p>  | <p><math>D_M =</math> <u>2.5</u> ft</p> <p><math>A_M =</math> <u>100</u> sq ft</p> <div style="border: 1px solid black; padding: 2px; margin: 5px 0;">             Choose One<br/> <input checked="" type="radio"/> Orifice Plate<br/> <input type="radio"/> Other (Describe):<br/>             _____<br/>             _____<br/>             _____         </div> <p><math>D_{orifice} =</math> <u>1.63</u> inches</p> <p><math>A_{ot} =</math> <u>6.36</u> square inches</p>  |

**Design Procedure Form: Extended Detention Basin (EDB)**

**Designer:** \_\_\_\_\_  
**Company:** Classic Consulting Engineers  
**Date:** February 18, 2022  
**Project:** Midtown Collection at Hannah Ridge Filing No. 3  
**Location:** EDB Forebay 1

|  |   |
|--|---|
| <p>8. Initial Surcharge Volume</p> <p>A) Depth of Initial Surcharge Volume<br/>(Minimum recommended depth is 4 inches)</p> <p>B) Minimum Initial Surcharge Volume<br/>(Minimum volume of 0.3% of the WQCV)</p> <p>C) Initial Surcharge Provided Above Micropool</p>  | <p><math>D_{IS} =</math> <u>6</u> in</p> <p><math>V_{IS} =</math> <u>43.2</u> cu ft</p> <p><math>V_s =</math> <u>50.0</u> cu ft</p>   |
| <p>9. Trash Rack</p> <p>A) Water Quality Screen Open Area: <math>A_t = A_{ot} * 38.5 * (e^{-0.095D})</math></p> <p>B) Type of Screen (If specifying an alternative to the materials recommended in the USDCM, indicate "other" and enter the ratio of the total open are to the total screen are for the material specified.)</p> <p style="padding-left: 40px;">Other (Y/N): <u>N</u></p> <p>C) Ratio of Total Open Area to Total Area (only for type 'Other')</p> <p>D) Total Water Quality Screen Area (based on screen type)</p> <p>E) Depth of Design Volume (EURV or WQCV)<br/>(Based on design concept chosen under 1E)</p> <p>F) Height of Water Quality Screen (<math>H_{TR}</math>)</p> <p>G) Width of Water Quality Screen Opening (<math>W_{opening}</math>)<br/>(Minimum of 12 inches is recommended)</p> | <p><math>A_t =</math> <u>210</u> square inches</p> <p><u>Aluminum Amico-Klemp SR Series with Cross Rods 2" O.C.</u></p> <hr/> <hr/> <p>User Ratio =</p> <p><math>A_{total} =</math> <u>296</u> sq. in.</p> <p><math>H =</math> <u>4.5</u> feet</p> <p><math>H_{TR} =</math> <u>82</u> inches</p> <p><math>W_{opening} =</math> <u>12.0</u> inches</p> |



**Design Procedure Form: Extended Detention Basin (EDB)**

**Designer:** \_\_\_\_\_  
**Company:** Classic Consulting Engineers  
**Date:** February 18, 2022  
**Project:** Midtown Collection at Hannah Ridge Filing No. 3  
**Location:** EDB Forebay 1

|   |  |
|---|--|
| <p>10. Overflow Embankment</p> <p>A) Describe embankment protection for 100-year and greater overtopping:</p><br><br><p>B) Slope of Overflow Embankment<br/>(Horizontal distance per unit vertical, 4:1 or flatter preferred)</p> | <p>_____</p> <p>_____</p> <p>_____</p>   |
| <p>11. Vegetation</p>   | <div style="border: 1px solid black; padding: 5px; display: inline-block;"> <p>Choose One</p> <p><input checked="" type="radio"/> Irrigated</p> <p><input type="radio"/> Not Irrigated</p> </div> <p style="color: blue; margin-left: 20px;">AVOID PLACING IRRIGATION HEADS<br/>IN THE BOTTOM OF THE BASIN</p> |
| <p>12. Access</p> <p>A) Describe Sediment Removal Procedures</p>  | <p>_____</p> <p>_____</p> <p>_____</p> <p>_____</p> <p>_____</p>   |
| <p>Notes: _____</p> <p>_____</p> <p>_____</p> <p>_____</p>  |  |

**Design Procedure Form: Extended Detention Basin (EDB)**

**Designer:** \_\_\_\_\_  
**Company:** Classic Consulting Engineers  
**Date:** October 18, 2021  
**Project:** Midtown Collection at Hannah Ridge Filing No. 3  
**Location:** EDB Forebay 2

|  |   |
|--|---|
| <p>5. Forebay</p> <p>A) Minimum Forebay Volume<br/>(<math>V_{FMIN} = \underline{3\%}</math> of the WQCV)</p> <p>B) Actual Forebay Volume</p> <p>C) Forebay Depth<br/>(<math>D_F = \underline{18}</math> inch maximum)</p> <p>D) Forebay Discharge</p> <p style="padding-left: 40px;">i) Undetained 100-year Peak Discharge</p> <p style="padding-left: 40px;">ii) Forebay Discharge Design Flow<br/>(<math>Q_F = 0.02 * Q_{100}</math>)</p> <p>E) Forebay Discharge Design</p><br><p>F) Discharge Pipe Size (minimum 8-inches)</p> <p>G) Rectangular Notch Width</p> | <p><math>V_{FMIN} = \underline{0.010}</math> ac-ft</p> <p><math>V_F = \underline{0.012}</math> ac-ft</p> <p><math>D_F = \underline{12.0}</math> in</p> <p><math>Q_{100} = \underline{12.00}</math> cfs</p> <p><math>Q_F = \underline{0.24}</math> cfs</p> <div style="border: 1px solid black; padding: 2px; display: inline-block; margin: 5px 0;">             Choose One<br/> <input type="radio"/> Berm With Pipe<br/> <input checked="" type="radio"/> Wall with Rect. Notch<br/> <input type="radio"/> Wall with V-Notch Weir         </div> <p style="color: blue; font-size: small;">(flow too small for berm w/ pipe)</p> <p>Calculated <math>D_p = \underline{\hspace{1cm}}</math> in</p> <p>Calculated <math>W_N = \underline{3.3}</math> in</p> |
| <p>6. Trickle Channel</p> <p>A) Type of Trickle Channel</p><br><p>F) Slope of Trickle Channel</p>  | <div style="border: 1px solid black; padding: 2px; display: inline-block; margin: 5px 0;">             Choose One<br/> <input checked="" type="radio"/> Concrete<br/> <input type="radio"/> Soft Bottom         </div> <p><math>S = \underline{0.0100}</math> ft / ft</p>   |
| <p>7. Micropool and Outlet Structure</p> <p>A) Depth of Micropool (2.5-feet minimum)</p> <p>B) Surface Area of Micropool (10 ft<sup>2</sup> minimum)</p> <p>C) Outlet Type</p><br><p>D) Smallest Dimension of Orifice Opening Based on Hydrograph Routing<br/>(Use UD-Detention)</p> <p>E) Total Outlet Area</p>   | <p><math>D_M = \underline{2.5}</math> ft</p> <p><math>A_M = \underline{100}</math> sq ft</p> <div style="border: 1px solid black; padding: 2px; display: inline-block; margin: 5px 0;">             Choose One<br/> <input checked="" type="radio"/> Orifice Plate<br/> <input type="radio"/> Other (Describe):         </div> <hr style="border: 0; border-top: 1px solid black; margin: 5px 0;"/> <hr style="border: 0; border-top: 1px solid black; margin: 5px 0;"/> <hr style="border: 0; border-top: 1px solid black; margin: 5px 0;"/> <p><math>D_{orifice} = \underline{1.63}</math> inches</p> <p><math>A_{ot} = \underline{6.36}</math> square inches</p>   |

## Site-Level Low Impact Development (LID) Design Effective Impervious Calculator

### LID Credit by Impervious Reduction Factor (IRF) Method

UD-BMP (Version 3.06, November 2016)

|  |                             |
|--|-----------------------------|
| User Input   |                             |
| Calculated cells   |                             |
| ***Design Storm: 1-Hour Rain Depth                                     | WQCV Event: 0.53 inches     |
| ***Minor Storm: 1-Hour Rain Depth                                      | 5-Year Event: 1.50 inches   |
| ***Major Storm: 1-Hour Rain Depth                                      | 100-Year Event: 2.52 inches |
| Optional User Defined Storm  | CUHP                        |
| (CUHP) NOAA 1 Hour Rainfall Depth and Frequency for User Defined Storm | 100-Year Event: 2.52        |
| Max Intensity for Optional User Defined Storm                          | 2.51496                     |

**Designer:** dlg  
**Company:** CLASSIC CONSULTING ENGINEERS  
**Date:** October 18, 2021  
**Project:** MIDTOWN AT HANNAH RIDGE FIL 3  
**Location:** \_\_\_\_\_

| Sub-basin Identifier   | A     | B-1   | C     | D     | E     | F     | D8,D10 | D1-D7  | D12   |  |  |  |  |  |
|--|-------|-------|-------|-------|-------|-------|--------|--------|-------|--|--|--|--|--|
| Receiving Pervious Area Soil Type  | Sand  | Sand  | Sand  | Sand  | Sand  | Sand  | Sand   | Sand   | Sand  |  |  |  |  |  |
| Total Area (ac., Sum of DCIA, UIA, RPA, & SPA)                             | 0.760 | 1.360 | 0.290 | 1.080 | 0.890 | 1.230 | 3.300  | 11.740 | 0.430 |  |  |  |  |  |
| Directly Connected Impervious Area (DCIA, acres)                           | 0.220 | 0.430 | 0.070 | 0.480 | 0.360 | 0.000 | 0.870  | 2.710  | 0.430 |  |  |  |  |  |
| Unconnected Impervious Area (UIA, acres)                                   | 0.340 | 0.240 | 0.030 | 0.170 | 0.090 | 0.060 | 0.680  | 2.580  | 0.000 |  |  |  |  |  |
| Receiving Pervious Area (RPA, acres)                                       | 0.000 | 0.530 | 0.190 | 0.430 | 0.320 | 0.280 | 1.750  | 6.290  | 0.000 |  |  |  |  |  |
| Separate Pervious Area (SPA, acres)  | 0.200 | 0.160 | 0.000 | 0.000 | 0.120 | 0.890 | 0.000  | 0.160  | 0.000 |  |  |  |  |  |
| RPA Treatment Type: Conveyance (C), Volume (V), or Permeable Pavement (PP) | C     | C     | C     | C     | C     | C     | C      | C      | C     |  |  |  |  |  |

| CALCULATED RESULTS (OUTPUT)   |              |              |              |              |              |             |              |              |               |  |  |  |  |  |
|---|--------------|--------------|--------------|--------------|--------------|-------------|--------------|--------------|---------------|--|--|--|--|--|
| Total Calculated Area (ac, check against input)                       | 0.760        | 1.360        | 0.290        | 1.080        | 0.890        | 1.230       | 3.300        | 11.740       | 0.430         |  |  |  |  |  |
| Directly Connected Impervious Area (DCIA, %)                          | 28.9%        | 31.6%        | 24.1%        | 44.4%        | 40.4%        | 0.0%        | 26.4%        | 23.1%        | 100.0%        |  |  |  |  |  |
| Unconnected Impervious Area (UIA, %)                                  | 44.7%        | 17.6%        | 10.3%        | 15.7%        | 10.1%        | 4.9%        | 20.6%        | 22.0%        | 0.0%          |  |  |  |  |  |
| Receiving Pervious Area (RPA, %)                                      | 0.0%         | 39.0%        | 65.5%        | 39.8%        | 36.0%        | 22.8%       | 53.0%        | 53.6%        | 0.0%          |  |  |  |  |  |
| Separate Pervious Area (SPA, %)                                       | 26.3%        | 11.8%        | 0.0%         | 0.0%         | 13.5%        | 72.4%       | 0.0%         | 1.4%         | 0.0%          |  |  |  |  |  |
| A <sub>p</sub> (RPA / UIA)  | 0.000        | 2.208        | 6.333        | 2.529        | 3.556        | 4.667       | 2.574        | 2.438        | 0.000         |  |  |  |  |  |
| I <sub>s</sub> Check  | 1.000        | 0.310        | 0.140        | 0.280        | 0.220        | 0.180       | 0.280        | 0.290        | 1.000         |  |  |  |  |  |
| f / I for WQCV Event:   | 11.0         | 11.0         | 11.0         | 11.0         | 11.0         | 11.0        | 11.0         | 11.0         | 11.0          |  |  |  |  |  |
| f / I for 5-Year Event:   | 0.6          | 0.6          | 0.6          | 0.6          | 0.6          | 0.6         | 0.6          | 0.6          | 0.6           |  |  |  |  |  |
| f / I for 100-Year Event:   | 0.6          | 0.6          | 0.6          | 0.6          | 0.6          | 0.6         | 0.6          | 0.6          | 0.6           |  |  |  |  |  |
| <b>f / I for Optional User Defined Storm CUHP:</b>                    | <b>0.57</b>  | <b>0.57</b>  | <b>0.57</b>  | <b>0.57</b>  | <b>0.57</b>  | <b>0.57</b> | <b>0.57</b>  | <b>0.57</b>  | <b>0.57</b>   |  |  |  |  |  |
| IRF for WQCV Event:   | 1.00         | 0.50         | 0.30         | 0.48         | 0.45         | 0.39        | 0.48         | 0.49         | 1.00          |  |  |  |  |  |
| IRF for 5-Year Event:   | 1.00         | 0.82         | 0.56         | 0.81         | 0.80         | 0.72        | 0.81         | 0.82         | 1.00          |  |  |  |  |  |
| IRF for 100-Year Event:   | 1.00         | 0.84         | 0.57         | 0.83         | 0.82         | 0.73        | 0.83         | 0.83         | 1.00          |  |  |  |  |  |
| <b>IRF for Optional User Defined Storm CUHP:</b>                      | <b>1.00</b>  | <b>0.84</b>  | <b>0.57</b>  | <b>0.83</b>  | <b>0.82</b>  | <b>0.73</b> | <b>0.83</b>  | <b>0.83</b>  | <b>1.00</b>   |  |  |  |  |  |
| Total Site Imperviousness: I <sub>total</sub>                         | 73.7%        | 49.3%        | 34.5%        | 60.2%        | 50.6%        | 4.9%        | 47.0%        | 45.1%        | 100.0%        |  |  |  |  |  |
| Effective Imperviousness for WQCV Event:                              | 73.7%        | 40.4%        | 27.3%        | 52.0%        | 45.0%        | 1.9%        | 36.3%        | 33.8%        | 100.0%        |  |  |  |  |  |
| Effective Imperviousness for 5-Year Event:                            | 73.7%        | 46.1%        | 29.9%        | 57.3%        | 48.6%        | 3.5%        | 43.1%        | 41.0%        | 100.0%        |  |  |  |  |  |
| Effective Imperviousness for 100-Year Event:                          | 73.7%        | 46.4%        | 30.1%        | 57.5%        | 48.7%        | 3.6%        | 43.5%        | 41.4%        | 100.0%        |  |  |  |  |  |
| <b>Effective Imperviousness for Optional User Defined Storm CUHP:</b> | <b>73.7%</b> | <b>46.4%</b> | <b>30.1%</b> | <b>57.5%</b> | <b>48.7%</b> | <b>3.6%</b> | <b>43.5%</b> | <b>41.4%</b> | <b>100.0%</b> |  |  |  |  |  |

| LID / EFFECTIVE IMPERVIOUSNESS CREDITS                |             |             |             |             |             |              |             |             |             |     |     |     |     |     |
|---|-------------|-------------|-------------|-------------|-------------|--------------|-------------|-------------|-------------|-----|-----|-----|-----|-----|
| WQCV Event CREDIT: Reduce Detention By:               | 0.0%        | 11.4%       | 13.4%       | 10.6%       | 7.2%        | 59.4%        | 14.3%       | 15.7%       | 0.0%        | N/A | N/A | N/A | N/A | N/A |
| This line only for 10-Year Event                      | N/A         | N/A         | N/A         | N/A         | N/A         | N/A          | N/A         | N/A         | N/A         | N/A | N/A | N/A | N/A | N/A |
| 100-Year Event CREDIT**:                              | 0.0%        | 5.8%        | 13.6%       | 4.3%        | 3.6%        | 45.9%        | 7.4%        | 8.2%        | 0.1%        | N/A | N/A | N/A | N/A | N/A |
| <b>User Defined CUHP CREDIT: Reduce Detention By:</b> | <b>0.0%</b> | <b>5.3%</b> | <b>9.5%</b> | <b>4.8%</b> | <b>3.4%</b> | <b>12.1%</b> | <b>6.5%</b> | <b>6.9%</b> | <b>0.0%</b> |     |     |     |     |     |

|  |              |
|--|--------------|
| <b>Total Site Imperviousness:</b>  | <b>46.3%</b> |
| <b>Total Site Effective Imperviousness for WQCV Event:</b>                       | <b>36.8%</b> |
| <b>Total Site Effective Imperviousness for 5-Year Event:</b>                     | <b>42.9%</b> |
| <b>Total Site Effective Imperviousness for 100-Year Event:</b>                   | <b>43.2%</b> |
| <b>Total Site Effective Imperviousness for Optional User Defined Storm CUHP:</b> | <b>43.2%</b> |

Notes:  
 \* Use Green-Ampt average infiltration rate values from Table 3-3.  
 \*\* Flood control detention volume credits based on empirical equations from Storage Chapter of USDCM.  
 \*\*\* Method assumes that 1-hour rainfall depth is equivalent to 1-hour intensity for calculation purposed

Figure 13-12c. Emergency Spillway Protection

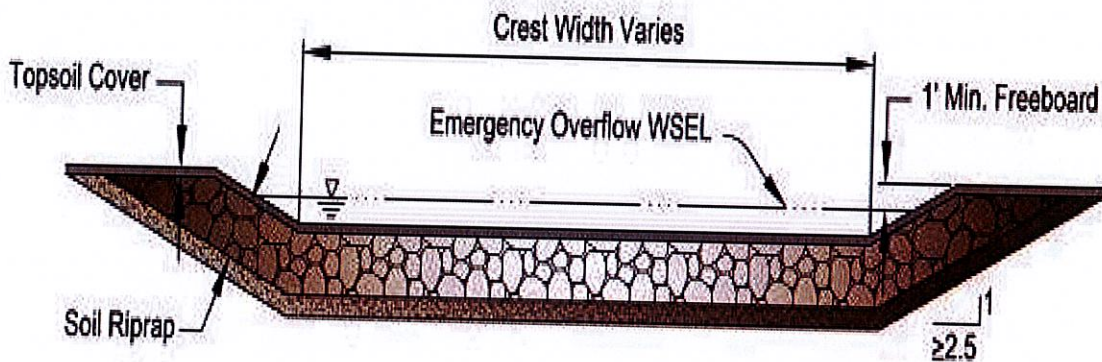
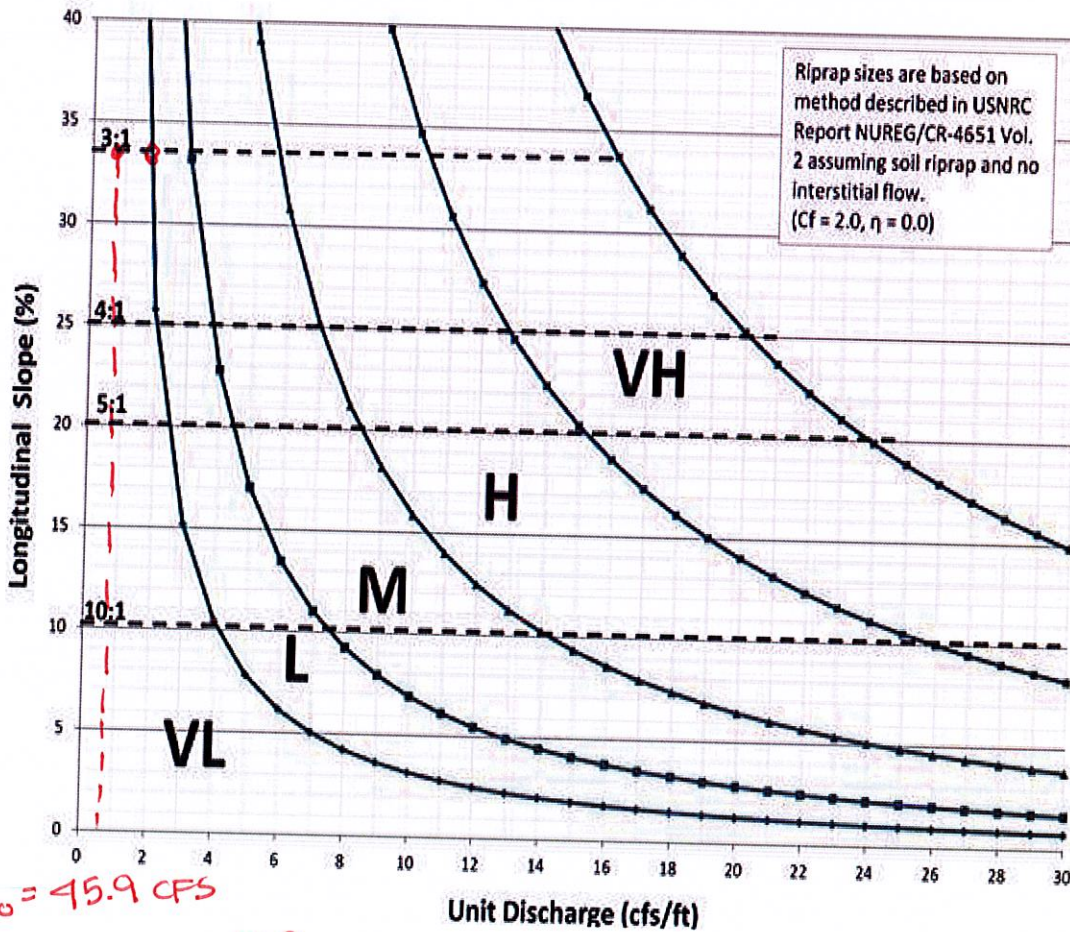

Figure 13-12d. Riprap Types for Emergency Spillway Protection



$Q_{100} = 45.9 \text{ cfs}$

$\text{UNIT DISCHARGE} = \frac{45.9}{65} = 0.71$

USE TYPE VL RIP-RAP

## DRAINAGE MAP

THIS DRAWING IS A MASTER PLANNING SHEET REPRESENTING PRELIMINARY AND CONCEPTUAL ENGINEERING. IT SHOULD NOT BE USED FOR CONSTRUCTION PURPOSES. THESE PLANS ARE SUBJECT TO CHANGE.

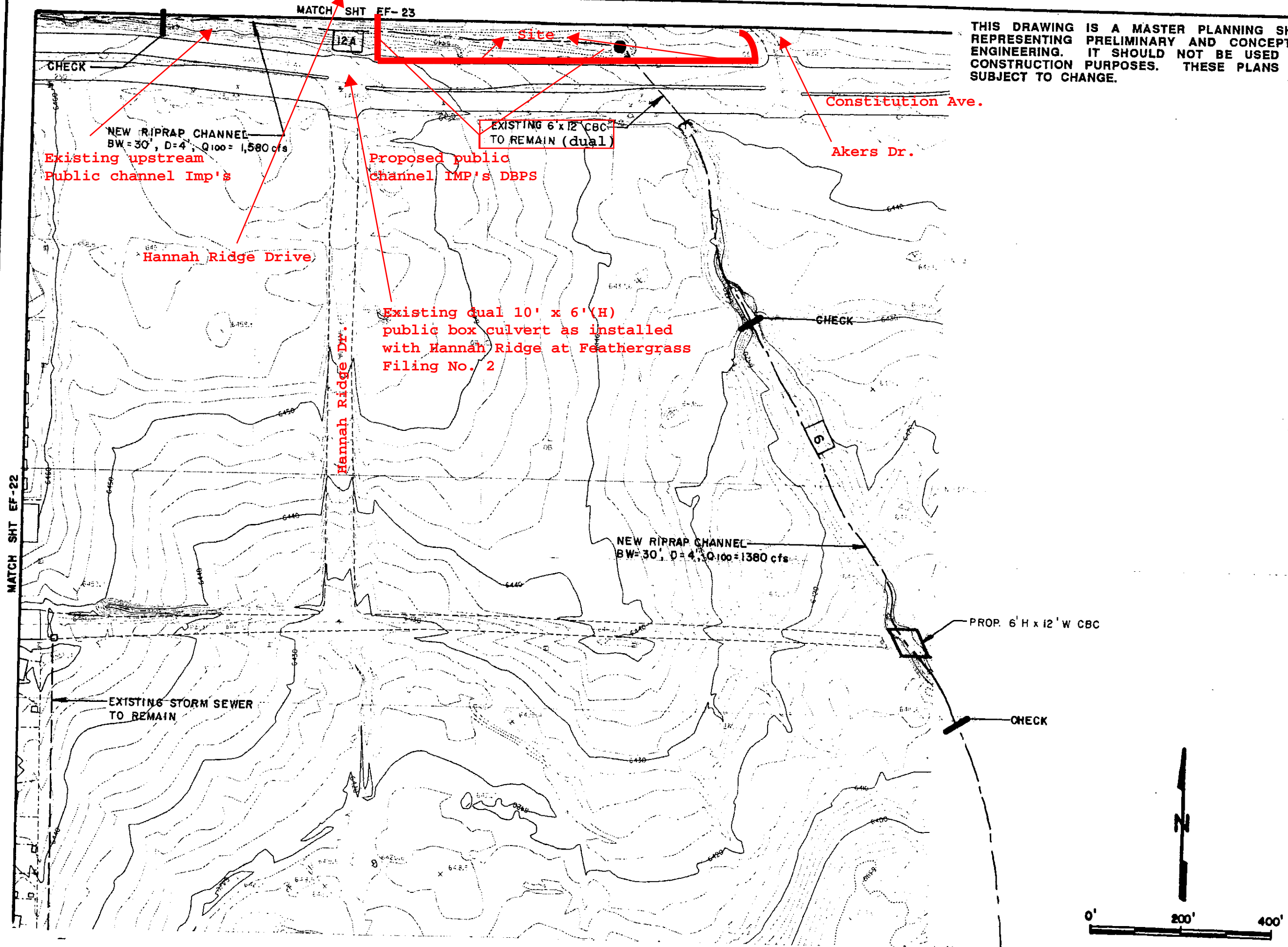

NEW RIPRAP CHANNEL  
BW=30', D=4', Q<sub>100</sub>=1,580 cfs  
Existing upstream  
Public channel Imp's

Hannah Ridge Drive

Proposed public  
channel IMP's DBPS

EXISTING 6' x 12' CBC  
TO REMAIN (dual)

Existing dual 10' x 6'(H)  
public box culvert as installed  
with Hannah Ridge at Feathergrass  
Filing No. 2

Constitution Ave.

Akers Dr.

NEW RIPRAP CHANNEL  
BW=30', D=4', Q<sub>100</sub>=1380 cfs

PROP. 6' H x 12' W CBC

EXISTING STORM SEWER  
TO REMAIN

CHECK

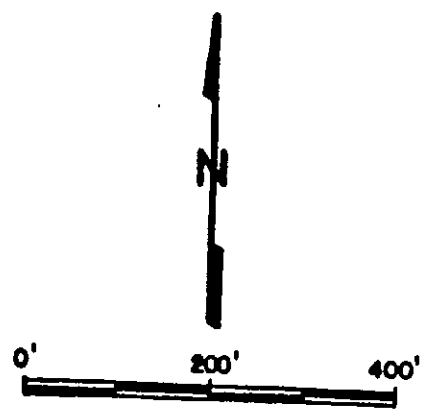

Kiowa Engineering Corporation  
419 W. Bijou Street  
Colorado Springs, Colorado  
80905-1308

SAND CREEK DRAINAGE  
BASIN PLANNING STUDY  
PRELIMINARY DESIGN PLANS

|            |  |
|------------|--|
| Project No |  |
| Date:      |  |
| Design:    |  |
| Drawn:     |  |
| Check:     |  |
| Revisions: |  |

MATCH SHT EF-19

