



INNOVATIVE DESIGN. CLASSIC RESULTS.

**EROSION CONTROL AND  
STORMWATER MANAGEMENT PLAN  
FOR  
MIDTOWN COLLECTION AT  
HANNAH RIDGE FILING NO. 3**

(EGP-20-007)

Prepared for:  
Classic Communities  
2138 Flying Horse Club Drive  
Colorado Springs, CO 80921  
(719) 592-9333

ATTN: Mr. Jim Boulton

Job no. 1116.35

Qualified Stormwater Manager:

Adam Doyle \_\_\_\_\_

2138 Flying Horse Club Dr. \_\_\_\_\_

Colorado Springs, CO 80921 \_\_\_\_\_

719-592-9333 \_\_\_\_\_

Contractor:

Cornella Brothers \_\_\_\_\_

3740 Silica Dr. \_\_\_\_\_

Colorado Springs, CO 80910 \_\_\_\_\_

719-390-1122 \_\_\_\_\_



**EROSION & STORMWATER QUALITY CONTROL PLAN FOR  
MIDTOWN COLLECTION AT HANNAH RIDGE FILING NO. 3**

**EROSION AND STORMWATER QUALITY STATEMENT**

**ENGINEER'S STATEMENT:**

The attached Erosion and Stormwater Quality Control Plan and Report were prepared under my direction and supervision and are correct to the best of my knowledge and belief. Said Erosion and Stormwater Quality Control Plan has been prepared according to the criteria established by the County for said reports.

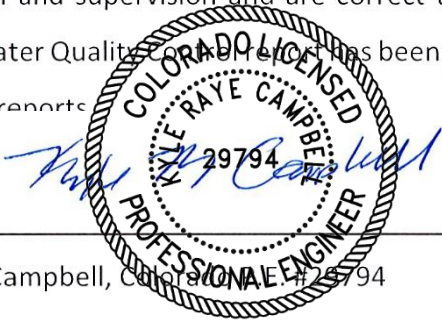

\_\_\_\_\_  
Kyle R. Campbell, Colorado License No. 29794

12/13/2021  
\_\_\_\_\_  
Date

**DEVELOPER'S STATEMENT:**

I acknowledge the responsibility to determine whether the construction activities on these plans require Colorado Discharge Permit System (CDPS) permitting for stormwater discharges associated with construction activity. The Owner will comply with the requirements of the Erosion and Stormwater Quality Control Plan.

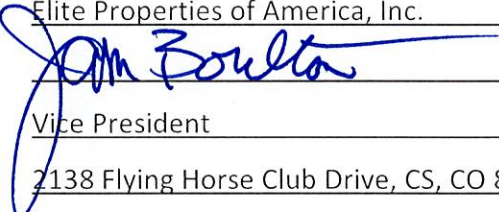
Business Name: Elite Properties of America, Inc.  
By:   
Title: Vice President  
Address: 2138 Flying Horse Club Drive, CS, CO 80921

**EL PASO COUNTY APPROVAL:**

Filed in accordance with El Paso County requirements.

\_\_\_\_\_  
County Engineer  
Conditions:

\_\_\_\_\_  
Date



# **EROSION & STORMWATER QUALITY CONTROL PLAN FOR MIDTOWN COLLECTION AT HANNAH RIDGE FILING NO. 3**

## **COLORADO DISCHARGE PERMIT SYSTEM STATEMENT (CDPS)/ EROSION AND STORMWATER QUALITY CONTROL PLAN (ESQCP)**

### **Site Inspector**

The following Erosion and Stormwater Quality Control Plan (ESQCP) is a detailed account of the requirements of the City of Colorado Springs Drainage Criteria Manual, Volume 2 – Stormwater Quality Policies, Procedures and Best Management Practices. The main objective of this plan is to help mitigate the increased soil erosion and subsequent deposition of sediment off-site and other potential stormwater quality impacts during the period of construction from start of earth disturbance until final landscaping and other potential permanent stormwater quality measures are effectively in place.

This document must be kept at the construction site at all times and be made available to the public and any representative of the Colorado Department of Health - Water Quality Control Division, if requested.

This report is also proposed to meet all requirements of the Colorado Discharge Permit System for Construction Activity. If any discrepancies between this report and Volume 2 exist, the City Manual will prevail.

# EROSION & STORMWATER QUALITY CONTROL PLAN FOR MIDTOWN COLLECTION AT HANNAH RIDGE FILING NO. 3

## TABLE OF CONTENTS

<b>SITE DESCRIPTION</b>	<b>Page 5</b>
▪ RECEIVING WATER(S)	Page 5
▪ PROPOSED CONSTRUCTION ACTIVITY	Page 5
▪ PROPOSED SEQUENCE OF ACTIVITIES/ CONSTRUCTION TIMING	Page 5
▪ EROSION & SEDIMENT CONTROL	Page 6
▪ DEVELOPMENT AREA	Page 6
▪ SOILS INFORMATION	Page 6
▪ EXISTING SITE CONDITIONS	Page 8
<b>SITE MAP (See Appendix)</b>	<b>Page 8</b>
<b>STORMWATER MANAGEMENT CONTROLS</b>	<b>Page 9</b>
▪ SWMP ADMINISTRATOR	Page 9
▪ POTENTIAL POLLUTANT SOURCES	Page 9
▪ BMPS FOR POLLUTION PREVENTION	Page 10
▪ BMP SELECTION	Page 10
▪ MATERIAL HANDLING & SPILL PREVENTION	Page 12
▪ CONCRETE/ASPHALT BATCH PLANTS	Page 15
▪ WASTE MANAGEMENT & DISPOSAL INCLUDING CONCRETE WASHOUT	Page 15
▪ DOCUMENTING SELECTED BMPS	Page 16
▪ NON-STORMWATER DISCHARGES	Page 16
▪ STORMWATER DEWATERING	Page 16
▪ REVISING BMPS AND THE SWMP	Page 16
<b>FINAL STABILIZATION AND LONG-TERM STORMWATER MANAGEMENT</b>	<b>Page 17</b>
<b>INSPECTION AND MAINTENANCE PROCEDURES</b>	<b>Page 17</b>
▪ SWMP OWNER/ADMINISTRATOR INSPECTION PROCEDURES & SCHEDULES	Page 18
▪ BMP MAINTENANCE/REPLACEMENT & FAILED BMPS	Page 18
▪ RECORD KEEPING AND DOCUMENTING INSPECTIONS	Page 18
▪ EROSION CONTROL COST ESTIMATE	Page 19
<b>APPENDIX</b>	
VICINITY MAP	
COPY OF GENERAL PERMIT APPLICATION	
OPERATION & MAINTENANCE INSPECTION RECORD	
COMPLETED OPERATION AND MAINTENANCE INSPECTION RECORDS	
STANDARD BMP DETAILS w/ INSTALLATION & MAINTENANCE REQUIREMENTS	
SITE MAP / EROSION AND STORMWATER QUALITY CONTROL PLAN	
QUALIFIED STORMWATER MANAGER CERTIFICATE	

# EROSION & STORMWATER QUALITY CONTROL PLAN FOR MIDTOWN COLLECTION AT HANNAH RIDGE FILING NO. 3

## SITE DESCRIPTION:

The proposed Hannah Ridge development is located in Section 32, Township 13 South, Range 65 west of the 6th p.m. in El Paso County, Colorado. The project site is on Constitution Avenue, west of Marksheffel Road and east of the Old Rock Island Railroad right of way. The site is located on the north side of Constitution Avenue. A portion of the land was previously platted as Akers-Acres Subdivision Filing No. 1. The project site is shown on the Vicinity Map in the Appendix of this report.

No wetlands, springs, landscape irrigation return flows or construction dewatering is anticipated on this site. Should any of the above items occur unexpectedly, BMPs shall be implemented immediately. The local regulatory agency shall be notified for approval of the BMPs and methods.

- **RECEIVING WATERS**

Name of Receiving Water(s)	Sand Creek east fork
Size/Type/Location of Outfall(s)	Existing Concrete box culvert at Constitution Ave.
Discuss discharge connection to Municipal system (include system name, location, and ultimate receiving water(s):	Site runoff to be conveyed in existing channel north of Constitution Ave then discharged into existing box culvert

- **PROPOSED CONSTRUCTION ACTIVITY**

Proposed construction activities within this project include overlot grading to of the project site, roadway infrastructure and utility infrastructure.

- **PROPOSED SEQUENCE OF ACTIVITY/CONSTRUCTION TIMING**

Proposed construction activities within this project include overlot grading, installation of wastewater mainline, storm sewer pipe, water mainline, curb & gutter, asphalt, dry utilities (gas/electric/telecom) as well as future home building construction. Sequence of activities will be based upon site contractor timing and scheduling. Upon site contractor selection, contractor to include sequence of activities schedule in the section provided in the Appendix of this report. A standard sequence of events typically includes the following, as applicable:

- 1) Install perimeter, interior & exterior BMPs
- 2) Clear and grub site
- 3) Rough overlot grading
- 4) Excavation & installation of utilities
- 5) Building construction
- 6) Paving, curb & gutter, sidewalk, landscaping.

- **EROSION AND SEDIMENT CONTROL**

Erosion control measures shall be implemented in a manner that will protect properties and public facilities from the adverse effects of erosion and sedimentation as a result of construction and earthwork activities. In order to prevent a net increase of sediment load, Best Management Practices will be implemented during the construction life of this project. A silt fence will be built around the perimeter of the disturbed areas. All roads will be inspected to ensure that sediment from on-site construction activity is not being discharged with the stormwater. Roadways shall be swept as needed for controlling tracking of mud onto public roadways. Vehicle tracking control pads will aid in minimizing soil tracking onto roadways. All disturbed areas, not sodded, will be reseeded with a native seed mix and watered until a mature stand is established. All areas disturbed will be protected with silt fence, diversion swales and temporary sediment basins until such time as the site has been re-vegetated. Diversion swales to be installed in locations by the Qualified Stormwater Manger to control and divert runoff as needed. Vegetation and vegetated buffers shall be preserved as much as possible. Wherever feasible, vegetated buffers shall be maintained free from vehicle/equipment parking, storage, stockpiles, or other impacts.

- **DEVELOPMENT AREA**

Total Site Area	<u>7.444</u> Acres
Site area to be disturbed	<u>7.444</u> Acres
Percent disturbance	<u>100</u> %

- **SOILS INFORMATION**

The average soil condition of the entire site and tributary area to the proposed ponds reflects Hydrologic Group “A” (Blakeland, loamy sand) as determined by the “Soil Survey of El Paso



County Area,” prepared by the National Cooperative Soil Survey. Based upon the current proposed development of this site, the following runoff coefficients would be realized:

Existing site runoff coefficient =	= <u>0.25</u>
Developed site runoff coefficient	= <u>0.8/.35 lots &amp; streets/ landscaped &amp; seeded areas</u>

The existing soil types have a slight potential for erosion which can be mitigated by employing appropriate downstream construction BMP’s before/during/after construction to limit potential impacts to stormwater discharges. The potential impacts are sediment discharge into the existing wet weather conveyance and proposed drainage system. Sediment should not be allowed to enter these existing and proposed facilities and can be mitigated by constructing small temporary sediment basins at low points prior to discharge into the systems. Potential wind erosion can be mitigated by the use of water truck during construction activities. Based upon the location of the different soil types and type of construction, the contractor shall employ the most appropriate method of erosion control measures based on the El Paso County / City of Colorado Springs Drainage Criteria Manual, Vol. 2 or as directed by the Qualified Stormwater Manager or his representatives.

**Table 3.1: SCS Soils Survey.**

Soil	Hydro. Group	Shrink/Swell Potential	Permeability	Surface Runoff Potential	Erosion Hazard
3-Ascalon Sandy Loam (2%)	B	Moderate	Moderate	Slow to Medium	Moderate
10-Blendon Sandy Loam (1%)	B	Low	Moderately Rapid	Slow	Moderate
52-Manzanst Clay Loam (11%)	C	Moderate to high	Slow	Medium	Moderate
54-Midway Clay Loam (10%)	D	High	Slow	Medium to Rapid	Moderate to High
56-Nelson-Tassel sandy loam (29%)	B	Moderate	Moderately Rapid	Slow	Moderate
104-Vona Sandy Loam (12%)	C	Moderate to High	Slow	Medium	Moderate
108-Vona Sandy Loam (35%)	B	Moderate	Moderate	Medium	Moderate

- **EXISTING SITE CONDITIONS**

The site is located within the Sand Creek Drainage Basin. Currently, the majority of this site drains to the center of the site in a southerly direction. Stormwater drains to the south across this site and is conveyed to the east along existing Constitution Avenue. An existing concrete box culvert under Constitution Avenue will convey the stormwater to the south along the historic drainage path.

This site is currently 90 % vegetated with native grasses and has existing slopes ranging from approximately 2 % to 30 % percent. The site was previously disturbed.

There are no areas designated as wetlands or streams within the development limits for this report.

### **SITE MAP**

Included in the appendix of this report is the approved overlot grading plan for the subject property which will serve as the SWMP site map. This document contains site specific grading and erosion control BMP measures as required and approved by the El Paso County Engineering division. Limits of disturbance, areas of cuts/fills, proposed stockpile areas, areas used for storage of materials, equipment, soil, or waste, batch plants, minimum and maximum cut/fill slopes, existing limits of significant vegetation, locations of springs, streams, and/or wetlands, and existing facilities (including but not limited to: detention/drainage facilities, structures, retaining walls, gas main, water main, wastewater main, electric and telecom vaults, fences, sidewalks, trails, curbs and streets) will be represented on this plan as applicable. The site map will depict locations of specific interim and ultimate stormwater management BMPs throughout the lifetime of the project. Erosion control cost assurances must be posted to City Engineering in the amount listed on the Title Page of the overlot grading plan prior to approval of the overlot grading plan. The site map/overlot grading plan shall be amended to include any additional interim or phased BMPs over and above measures included on the site map, as required by contractor's construction schedule. All construction BMP details will be included in the appendix of this report. Detail sheets include installation and maintenance requirements. Also reference "Drainage Criteria Manual, Volume 2 Stormwater Quality Policies, Procedure, and Best Management Practices" for additional information and guidance regarding construction BMPs.

This project does not rely on control measures owned or operated by another entity.



## **STORMWATER MANAGEMENT**

- **SWMP ADMINISTRATOR**

The Qualified Stormwater Manager can be an individual(s), position, or title – this entity is responsible for developing, implementing, maintaining, and revising the SWMP. The Qualified Stormwater Manager is the contact for all SWMP related issues and is the entity responsible for its accuracy, completeness, and implementation. Therefore, the Qualified Stormwater Manager should be a person with authority to adequately manage and direct day to day stormwater quality management activities on the subject site. Reference the cover page and the Appendix of this report for the SWMP permit application which names the individual/entity applying for the permit and naming the Qualified Stormwater Manager of the SWMP.

The Quality Stormwater Manager will be sufficiently qualified for the required duties per the Engineering Criteria Manual appendix 1.5 Item 26.

- **POTENTIAL POLLUTANT SOURCES**

Potential pollutant sources which shall be evaluated for potential to contribute pollutants to stormwater discharge from the subject site may include the following:

- Disturbed and stored soils
- Vehicle tracking of sediments
- Management of contaminated soils
- Loading and unloading operations
- Outdoor storage activities (building materials, fertilizers, chemicals, etc.)
- Vehicle and equipment maintenance and fueling
- Significant dust or particulate generating processes
- Routine maintenance activities involving fertilizers, pesticides, detergents, fuels, solvents, oils, etc.
- On-site waste management practices (waste piles, liquid wastes, dumpsters)
- Concrete truck/equipment washing, including the concrete truck chute associated fixtures and equipment
- Dedicated asphalt and concrete batch plants
- Non-industrial waste sources such as worker trash and portable toilets
- Other areas or procedures where potential spills can occur.

The location and description of these areas are shown on the attached SWMP Site Map, as applicable.

- **BMPS FOR POLLUTANT PREVENTION**

The following are common practices to mitigate potential pollutants:

- Wind erosion shall be controlled by sprinkling site roadways and/or temporary stabilizing stockpiles. Each dump truck hauling material from the site will be required to be covered with a tarpaulin.
- Toilets: Portable toilet facilities will be located a minimum of 10 feet from stormwater inlets and 50 feet from state waters. They shall be adequately staked and cleaned on a weekly basis. They will be inspected for spills.
- Equipment fueling and Maintenance Services – a designated fueling area will be established to contain any spill resulting from fueling, maintenance, or repair of equipment. Contractors will be responsible for containment, cleanup, and disposal of any leak or spill and any costs associated with the cleanup and disposal.
- Chemical products shall be protected from precipitation, free from ground contact, and stored properly to prevent damage from equipment or vehicles.
- Material stockpiles (soils, soil amendments, debris/trash piles) – All construction trash and debris will be deposited in the dumpster.
- Sediment and Migration of Sediment – Sweeping operations will take place as needed to keep roadways maintained. The perimeter of the site will be evaluated for any potential impact resulting from trucking operations or sediment migration from the site. BMP devices will be placed to protect storm system inlets should any roadway tracking or sediment migration occur.
- Snow removal and/or stockpiling will be considered prior to placement at the site. Snow stockpiles must be kept away from any stormwater conveyance system (i.e., inlets, ponds, outfall locations, roadway surfaces, etc.).

- **BMP SELECTION**

Selection of the appropriate BMP will limit the source of the pollutant. Guidance for the selection process can be found by referencing the City of Colorado Springs “Drainage Criteria Manual Volume 2”.

During grading and construction activity for the subject site, silt fence will be installed along the perimeter of the site as well as at the limits of grading within the project. Check dams will be installed along all permanent and temporary diversion swales to minimize erosion in areas of concentrated stormwater. Temporary diversion swales will be installed to a minimum of 1% slope to divert stormwater to several proposed sediment basins intended to collect stormwater and filter the sediment before conveyance into the proposed storm systems. Diversion swales to be installed in locations by the Qualified Stormwater Manager to control and divert runoff as needed. Inlet protection will be installed at all proposed and adjacent inlets to ensure no downstream pollutants will enter storm sewer facilities. Vehicle tracking control pads will be installed at all access points to the property. Straw bale barriers will be installed within the public and private roadways to minimize erosion in areas of concentrated flows. Rolled erosion control products will be installed on 3:1 slopes to minimize concentrated runoff. Regular maintenance and inspection of these facilities will be necessary throughout grading operations and until vegetation is reestablished to ensure proper function of the sediment basin temporary outlet structures. BMP phasing shall contain initial, interim and final phases for this project. Initial BMPs installed prior to grading beginning (or as grading begins) to include silt fencing and inlet protection. Interim BMPs to be installed and used throughout grading, specifically vehicle tracking control, straw bale barriers and temporary sediment basins. Final BMPs to include permanent stormwater quality facilities, erosion control netting, re-seeding of disturbed areas and interim control measure maintenance until final establishment after home site construction.

This project does not rely on control measures owned or operated by another entity. All proposed temporary construction control measure details, custom or jurisdictional details used must meet or exceed El Paso County standards. Initial temporary construction control methods to include inlet protection and silt fencing. Interim temporary construction control methods to include vehicle tracking, roadway straw bale barriers and temporary sediment basins. Final methods to include permanent stormwater quality ponds and continual maintenance of initial and interim methods as well as erosion control blanketing and final re-seeding establishment throughout home building at ultimate development.

- **MATERIAL HANDLING & SPILL PREVENTION**

**Material Handling and Waste Management**

The site will use a private refuse collector that will remove litter twice weekly. No less than one litter receptacle will be present at the construction site. In the event that unusual items such as tanks, cylinders, unidentified containers, etc. which would contain potentially hazardous materials are discovered or disturbed, the Fire and Rescue services will be notified. Litter and debris will be picked up and disposed of properly daily. Temporary toilet facilities will be located 500 feet away from any storm drain inlets and all waters of the state.

**Establish Proper Building Material Staging Areas**

A designated staging area will be used, location to be determined based on available space in the field and plans will be redline. The staging area will be contained per SWMP guidelines. All Equipment and Materials will be brought into the site as needed.

**Designate Washout Areas**

A concrete washout, if applicable, will be installed to detail as shown on the Construction Drawings and will be placed more than 500 feet away from any waters of the state.

**Establish Proper Equipment/Vehicle Fueling and Maintenance Practices**

During construction the site will be exposed to operation and maintenance of construction equipment. The contractor shall be responsible for all activities such as fueling, oil changing, lubrication and repair which require use of petroleum products. Such products shall be transported to and from the site in special trucks equipped for that purpose. No waste petroleum products, rags, residue, or equipment parts shall be left on site. In the event of a spill or leak, causing soil to be contaminated, that soil shall be excavated placed in sealed barrels and removed from the site for transport to an approved location for disposal.

**Control Equipment/Vehicle Washing**

This activity will not be allowed onsite.

**Any Additional BMP's**

Additional BMP's will be added to this SWMP as needed.

### **Allowable Non-Stormwater Discharge Management**

There are no visible natural springs or irrigation, or other non-stormwater discharges anticipated to be encountered.

### **Selecting Post Construction BMP's**

Post Construction BMP's. Re-vegetation including seeding, mulching and erosion control blanket will be final BMP's. Permanent stabilization will be achieved with 70% pre construction vegetative establishment.

### **Spill Prevention and Control Plan**

The SITE SUPERINTENDENT will act as the point of contact for any spill that occurs at this jobsite. The project manager will be responsible for implementation of prevention practices, spill containment/cleanup, worker training, reporting and complete documentation in the event of a spill. The ECO shall immediately notify the Owner, Construction Manager, STATE and the Local Fire Department in addition to the legally required Federal, State and Local reporting channels (including the National Response Center, 800.424.8802) if a reportable quantity is released to the environment. The Spill Prevention Plan is to be included / stored with the SWMP on-site.

### **Spill Prevention and Best Management Practices**

This section describes spill prevention methods Best Management Practices (BMP) that will be practiced to eliminate spills before they happen.

- Equipment Staging and Maintenance: Store and maintain equipment in a designated area. Reduce the amount of hazardous materials and waste by substituting non-hazardous or less hazardous materials. Use secondary containment (drain pan) to catch spills when removing or changing fluids. Use proper equipment (pumps, funnels) to transfer fluids. Keep spill kits readily accessible. Check incoming vehicles for leaking oil and fluids. Transfer used fluids and oil filters to waste or recycling drums immediately following generation. Inspect equipment routinely for leaks and spills. Repair equipment immediately, if necessary, implement a preventative maintenance schedule for equipment and vehicles.
- Fueling Area: Perform fueling in designated fueling area, minimum 50' away from federal waters. Use secondary containment (drain pan) to catch spills. Use proper equipment (pumps, funnels) to transfer fluids. Keep spill kits readily accessible. Inspect fueling areas

routinely for leaks and spills. Hazardous Materials Storage Areas. Reduce the amount of hazardous materials by substituting non-hazardous or less hazardous materials.

- Hazardous Material Storage Areas: Minimize the quantity of hazardous materials brought onsite. Store hazardous materials in a designated area away from drainage points.
- Unexpected Contaminated Soil and Water: Perform all excavation activities carefully and only after the Owner/Construction Manager directed any activities.

### **Spill Containment Methods**

The following discussion identifies the types of secondary containment that will be used in the event of a spill. The Table below summarizes the containment methods for each potential source.

- Equipment Staging and Maintenance Area: An equipment leak from a fuel tank, equipment seal, or hydraulic line will be contained within a spill containment cell placed beneath all stationary potential leak sources. An undetected leak from parked equipment will be cleaned up using hand shovels and containerized in a 55-gallon steel drum for offsite disposal.
- Fueling Area: A small spill during fuel operations will be contained using fuel absorbent pads at the nozzle. The transfer of fuel into portable equipment will be performed using a funnel and/or hand pump and a spill pad used to absorb any incidental spills/drips. Any leaking tanks or drums will have fluids removed and transferred to another tank, drum, or container for the fluids. A spill response kit will be located near the fueling area or on the fuel truck for easy access. The spill response kit will include plastic sheeting, tarps, over pack drums absorbent litter, and shovels.
- Hazardous Material Storage Area: A spill from containers or cans in a hazardous material storage area will be contained within the storage cabinet these materials are kept in.
- Unexpected Contaminated Soil: If contaminated soil is encountered during the project, the Owner/Construction Manager will be notified immediately. Small quantities of suspected contaminated soil will be placed on a 6-mil plastic liner and covered with 6-mil plastic. A soil berm or silt fence will be used to contain the stockpile and prevent migration of contaminated liquids in the soil.

### **Spill Countermeasures**

Every preventative measure shall be taken to keep contaminated or hazardous materials contained.

If a release occurs, the following actions shall be taken:

1. **Stop the Spill:** The severity of a spill at the site is anticipated to be minimal as large containers/quantities of Hazardous Materials (HM) are not anticipated. The type of spill would occur while dispensing material at the HM storage facility and would likely be contained in secondary containment. Thus, the use of spill kits or other available absorbent materials should stop the spill.
2. **Warn Others:** Notify co-workers and supervisory personnel of the release. Notify emergency responders if appropriate. For site personnel, an alarm system will consist of three one second blasts on an air horn sounded by the person discovering a spill or fire. In the event of any spill, the Superintendent and Project Manager shall be notified. If the spill is 5 gallons or more, the STATE will be contacted along with the Fire Department
3. **Isolate the Area:** Prevent public access to the area and continue to minimize the spread of the material. Minimize personal exposure throughout emergency response actions.
4. **Containment:** A spill shall only be contained by trained personnel and if it is safe to do so. **DO NOT PLACE YOURSELF IN DANGER.** Attempt to extinguish a fire only if it is in the incipient stage; trash can size or smaller. For larger spills, wait for the arrival of emergency response personnel and provide directions to the location of the emergency.
5. **Complete a Spill and Incident Report:** For each spill of a Hazardous Material, a spill and incident report shall be completed and submitted to the Owner/Construction Manager and if applicable, to the Engineer and the State of Colorado Department of Public Health and Environment.

- **CONCRETE/ASPHALT BATCH PLANTS**

Where applicable, the SWMP must be amended by the contractor to describe and locate on the Site Map all practices used to control stormwater pollution from dedicated asphalt or concrete batch plants. However, no batch plants are planned for this site.

- **WASTE MANAGEMENT AND DISPOSAL INCLUDING CONCRETE WASHOUT**

Where applicable, the SWMP must be amended by the contractor to describe and locate on the Site Map all practices implemented at the site to control stormwater pollution from all construction site wastes (liquid and solid) including concrete washout activities.

- **DOCUMENTING SELECTED BMPS**

As discussed in the SITE MAP section of this report, documentation of the selected BMPS will be included on the site map / overlot grading plan included in this report. The site map/overlot grading plan shall be amended to include any additional interim or phased BMPS over and above measures included on the site map, as required by contractor's construction schedule.

- **NON-STORMWATER DISCHARGES**

Except for emergency firefighting activities, landscape irrigation return flow, uncontaminated springs, construction dewatering and concrete washout water, the SWMP permit covers only discharges composed entirely of stormwater.

- **STORMWATER DEWATERING**

The discharge of pumped water, ONLY from excavations, ponds, depressions, etc., to surface waters or to a municipal separate storm-sewer system is allowed by the Stormwater Construction Permit as long as the dewatering activity and associated BMPS are identified in the SWMP (including location of activity), and the BMPS are implemented in accordance with the SWMP. Where applicable, all stormwater and groundwater dewatering practices implemented to control stormwater pollution for dewatering must be amended in the SWMP and Site Map by the contractor. Dewatering is not anticipated for this site.

- **REVISING BMPS AND THE SWMP**

The implemented BMPS will need to be modified and maintained regularly to adapt to changing site conditions and to ensure that all potential stormwater pollutants are properly managed. The BMPS and pollutant sources must be reviewed on an ongoing basis by the Administrator as assigned by the Permit. With any construction project, special attention must be paid to construction phasing and therefore revisions to the SWMP to include any additional or modification to the BMPS and SWMP report. The SWMP must be modified or amended by the SWMP Administrator to accurately reflect the field conditions. Examples include - but are not limited to – removal of BMPS, identification of new potential pollutant procedures, and changes to information provided in the site map/overlot grading plan. SWMP revisions must be made prior to changes in site conditions. The SWMP should be viewed as a “living document” throughout the lifetime of the project.



## **FINAL STABILIZATION AND**

### **LONG-TERM STORMWATER MANAGEMENT**

Permanent stabilization of the site includes seeding and mulching the site. Seeding and mulching consists of loosening soil, applying topsoil (if permanent seeding) and drill seeding disturbed areas with grasses and crimping in straw mulch to provide immediate protection from raindrop and wind erosion. As the grass cover becomes established, provide long term stabilization of exposed soils.

Once the construction activity ceases permanently, the area will be stabilized with permanent seed and mulch. All areas that will not be impacted by construction of buildings will be seeded and landscaped as feasible. After seeding, each area will be mulched with straw. The straw mulch is to be tacked into place by a disc with blades set nearly straight. Topsoil stockpiles will be stabilized with temporary seed and mulch. Areas of the site that are to be paved will be temporarily stabilized until asphalt is applied.

The temporary perimeter controls (silt fence or equivalent) will not be removed until all construction activities at the site are complete and soils have been stabilized. Upon completion of construction activities, the site shall be inspected to ensure all equipment, waste materials, and debris have been removed. All other BMPs or other control practices and measure that are to remain after completion of construction will be inspected to ensure they are properly functioning. Final stabilization is reached when all soil disturbing activities at the site have been completed and uniform vegetative cover has been established with a density of at least 70% of pre-disturbance levels. For purposes of the SWMP, establishment of a vegetative cover capable of providing erosion control equivalent to the pre-existing conditions at the site can be considered final stabilized.

Long term stormwater quality management will be handled by the proposed on-site stormwater quality and detention facilities proposed in the Final Drainage Reports by CCES. All facilities will detain stormwater to release rates less than or equal to historic levels as well as provide water quality capture volume prior to releasing stormwater to downstream facilities.

### **INSPECTION AND MAINTENANCE PROCEDURES**

All drainage facilities will be monitored using the enclosed "Monitoring and Maintenance Inspection Record" checklist (Appendix II).

- **SWMP OWNER/ADMINISTRATOR INSPECTION PROCEDURES & SCHEDULES**

The Owner/Administrator shall adhere to the following inspection procedures during the development of the site:

1. Make thorough inspection of the stormwater management system at least every 14 days.
2. Make thorough inspection of the stormwater management system within 24 hrs of each precipitation event that creates runoff.
3. If any system deficiencies are noted, corrective actions must begin immediately. Documentation of inspection must be available if requested.
4. Records of the site inspections or facility replacement modifications must be kept at the site within this report.
5. 30-day inspections must take place on this site where construction activity is complete, but vegetative cover is still being established.

In this report's appendix, a site inspection form has been included for use by the Inspector. Upon completion of this form, the document is to be kept in the provided folder also in the rear of this report.

- **BMP MAINTENANCE / REPLACEMENT & FAILED BMPs**

The Stormwater Construction Permit requires that all erosion and sediment control practices and other protective measures identified in the SWMP be maintained in effective and operation condition. A preventative maintenance program should be in place to prevent BMP breakdowns and failures by proactively maintaining or replacing BMPs and equipment. The inspections process should also include procedures to ensure that BMPs are replaced or new BMPs added to adequately manage the pollutant sources at the site. This procedure is part of the ongoing process of revising the BMPs and SWMP as previously discussed, and any changes shall be recorded in the SWMP.

- **RECORD KEEPING AND DOCUMENTING INSPECTIONS**

The following items must be documented as part of the site inspections:

- Inspection date
- Name(s), title(s) and signature(s) of personnel making inspection
- Location(s) of discharges of sediment or other pollutants from site
- Location(s) of BMPs that need to be maintained

- Location(s) of BMPs that fail to operate as designed or proved inadequate in a particular location
- Location(s) where additional BMPs are needed that were not in place at time of inspection
- Deviations from the minimum inspection schedule
- Descriptions of corrective action for items above including dates and measures taken to prevent future violations
- Signed statement of compliance added to the report after correction action has been taken.

**EROSION CONTROL COST OPINION**

ITEM	DESCRIPTION	QUANTITY	UNIT COST	COST
1.	Vehicle Tracking Control	1 EACH	\$2,370/EA	\$ 2,370.00
2.	Silt Fence	3,450 LF	\$2.50/LF	\$ 8,625.00
3.	Temporary Seeding	5 AC.	\$628/AC.	\$ 3,140.00
4.	Temporary Mulch	5 AC.	\$750/AC.	\$ 3,750.00
5.	Sediment Basin	3 EACH	\$1,762/EA	\$ 5,286.00
	Maintenance (35% of construction BMPs)			\$ 8,109.85
<b>TOTAL</b>				<b><u>\$ 31,280.85</u></b>

Classic Consulting Engineers & Surveyors cannot and does not guarantee that the construction cost will not vary from these opinions of probable construction costs. These opinions represent our best judgment as design professionals familiar with the construction industry and this development in particular.

PREPARED BY:

**Classic Consulting Engineers & Surveyors, LLC**

Keith Cerjan  
Project Designer

kc/111635/reports/ swmp report fil 3.doc



## VICINITY MAP

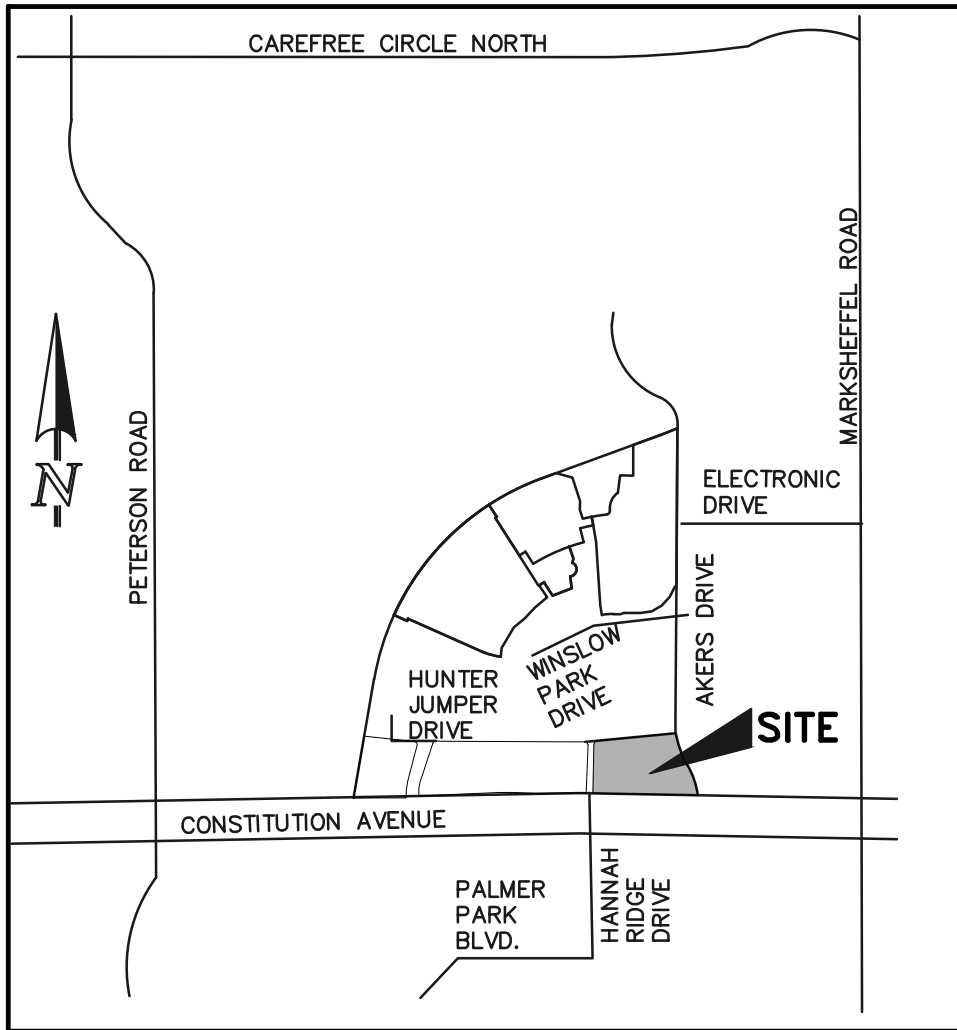

VICINITY MAP

N.T.S.

**COPY OF PERMIT APPLICATION**

General permit application for stormwater discharges associated with construction activity.

**(TO BE PROVIDED PRIOR TO PLAN APPROVAL)**



# COLORADO

Department of Public Health & Environment

Dedicated to protecting and improving the health and environment of the people of Colorado

ASSIGNED PERMIT NUMBER

Date Received \_\_\_\_/\_\_\_\_/\_\_\_\_  
MM DD YYYY  
Revised: 10-2017

## STORMWATER DISCHARGE ASSOCIATED WITH CONSTRUCTION ACTIVITIES APPLICATION COLORADO DISCHARGE PERMIT SYSTEM (CDPS)

**PHOTO COPIES, FAXED COPIES, PDF COPIES OR EMAILS WILL NOT BE ACCEPTED.**

**For Applications submitted on paper - Please print or type. Original signatures are required.**

All items must be completed accurately and in their entirety for the application to be deemed complete. Incomplete applications will not be processed until all information is received which will ultimately delay the issuance of a permit. If more space is required to answer any question, please attach additional sheets to the application form. Applications or signature pages for the application may be submitted by mail or hand delivered to:

Colorado Department of Public Health and Environment, 4300 Cherry Creek Drive South, WQCD-P-B2, Denver, CO 80246-1530

**For Applications submitted electronically**

Please note that you can ONLY complete the feedback form by downloading it to a PC or Mac/Apple computer and opening the Application with Adobe Reader or a similar PDF reader. The form will NOT work with web browsers, Google preview, Mac preview software or on mobile devices using iOS or Android operating systems.

If application is submitted electronically, processing of the application will begin at that time and not be delayed for receipt of the signed document.

Any additional information that you would like the Division to consider in developing the permit should be provided with the application. Examples include effluent data and/or modeling and planned pollutant removal strategies.

**Beginning July 1, 2016, invoices will be based on acres disturbed.**

**DO NOT PAY THE FEES NOW - Invoices will be sent after the receipt of the application.**

Disturbed Acreage for this application (see page 4)

- Less than 1 acre (\$83 initial fee, \$165 annual fee)
- 1-30 acres (\$175 initial fee, \$350 annual fee)
- Greater than 30 acres (\$270 initial fee, \$540 annual fee)

### PERMIT INFORMATION

Reason for Application:  NEW CERT  RENEW CERT EXISTING CERT# \_\_\_\_\_

Applicant is:  Property Owner  Contractor/Operator

### A. CONTACT INFORMATION - \*indicates required

\* PERMITTED ORGANIZATION FORMAL NAME: \_\_\_\_\_

1) \* PERMIT OPERATOR - the party that has operational control over day to day activities - may be the same as owner.

Responsible Person (Title): \_\_\_\_\_

Currently Held By (Person): FirstName: \_\_\_\_\_ LastName: \_\_\_\_\_

Telephone: \_\_\_\_\_ Email Address: \_\_\_\_\_

Organization: \_\_\_\_\_

Mailing Address: \_\_\_\_\_

City: \_\_\_\_\_ State: \_\_\_\_\_ Zip Code: \_\_\_\_\_

**Per Regulation 61** : All reports required by permits, and other information requested by the Division shall be signed by the permittee or by a duly authorized representative of that person. A person is a duly authorized representative only if:

- (i) The authorization is made in writing by the permittee
- (ii) The authorization specifies either an individual or a position having responsibility for the overall operation of the regulated facility or activity such as the position of plant manager, operator of a well or a well field, superintendent, position of equivalent responsibility, or an individual or position having overall responsibility for environmental matters for the company. (A duly authorized representative may thus be either a named individual or any individual occupying a named position); and
- (iii) The written authorization is submitted to the Division

2) **OWNER - party has ownership or long term lease of property - may be the same as the operator.**

Same as 1) Permit Operator

Responsible Person (Title): \_\_\_\_\_

Currently Held By (Person): FirstName: \_\_\_\_\_ LastName: \_\_\_\_\_

Telephone: \_\_\_\_\_ Email Address: \_\_\_\_\_

Organization: \_\_\_\_\_

Mailing Address: \_\_\_\_\_

City: \_\_\_\_\_ State: \_\_\_\_\_ Zip Code: \_\_\_\_\_

**Per Regulation 61** : All reports required by permits, and other information requested by the Division shall be signed by the permittee or by a duly authorized representative of that person. A person is a duly authorized representative only if:

- i. The authorization is made in writing by the permittee.
- ii. The authorization specifies either an individual or a position having responsibility for the overall operation of the regulated facility or activity such as the position of plant manager, operator of a well or a well field, superintendent, position of equivalent responsibility, or an individual or position having overall responsibility for environmental matters for the company. (A duly authorized representative may thus be either a **named individual** or any individual occupying a **named position**); and
- iii. The written authorization is submitted to the Division.

3) **\*SITE CONTACT** local contact for questions relating to the facility & discharge authorized by this permit for the facility

Same as 1) Permit Operator

Responsible Person (Title): \_\_\_\_\_

Currently Held By (Person): FirstName: \_\_\_\_\_ LastName: \_\_\_\_\_

Telephone: \_\_\_\_\_ Email Address: \_\_\_\_\_

Organization: \_\_\_\_\_

Mailing Address: \_\_\_\_\_

City: \_\_\_\_\_ State: \_\_\_\_\_ Zip Code: \_\_\_\_\_

4) **\*BILLING CONTACT** if different than the permittee.

Same as 1) Permit Operator

Responsible Person (Title): \_\_\_\_\_

Currently Held By (Person): FirstName: \_\_\_\_\_ LastName: \_\_\_\_\_

Telephone: \_\_\_\_\_ Email Address: \_\_\_\_\_

Organization: \_\_\_\_\_

Mailing Address: \_\_\_\_\_

City: \_\_\_\_\_ State: \_\_\_\_\_ Zip Code: \_\_\_\_\_

5) **OTHER CONTACT TYPES (check below) Add pages if necessary:**

Responsible Person (Title): \_\_\_\_\_

Currently Held By (Person): FirstName: \_\_\_\_\_ LastName: \_\_\_\_\_

Telephone: \_\_\_\_\_ Email Address: \_\_\_\_\_

Organization: \_\_\_\_\_

Mailing Address: \_\_\_\_\_

City: \_\_\_\_\_ State: \_\_\_\_\_ Zip Code: \_\_\_\_\_

Environmental Contact

Consultant

Stormwater MS4 Responsible Person

Inspection Facility Contact

Compliance Contact

Stormwater Authorized Representative



**B) PERMITTED PROJECT/FACILITY INFORMATION**

Project/Facility Name \_\_\_\_\_

Street Address or Cross Streets \_\_\_\_\_

(e.g., Park St and 5 Ave; CR 21 and Hwy 10; 44 Ave and Clear Creek) ; A street name without an address, intersection, mile marker, or other identifying information describing the location of the project is not adequate. For **linear projects**, the route of the project should be described as best as possible using the starting point for the address and latitude and longitude - more clearly defined in the required map )

City: \_\_\_\_\_ County: \_\_\_\_\_ Zip Code: \_\_\_\_\_

**Facility Latitude/Longitude** - List the latitude and longitude of the excavation(s) resulting in the discharge(s). If the exact soil disturbing location(s) are not known, list the latitude and longitude of the center point of the construction project. If using the center point, be sure to specify that it is the center point of construction activity. The preferred method is GPS and Decimal Degrees.

Latitude \_\_\_\_\_ . \_\_\_\_\_ Longitude \_\_\_\_\_ . \_\_\_\_\_ (e.g., 39.70312°, 104.93348°)  
Decimal Degrees (to 5 decimal places)                      Decimal Degrees (to 5 decimal places)

This information may be obtained from a variety of sources, including:

- **Surveyors or engineers** for the project should have, or be able to calculate, this information.
- **U.S. Geological Survey topographical map(s)**, available at area map stores.
- Using a **Global Positioning System (GPS) unit** to obtain a direct reading.
- **Google** - enter address in search engine, select the map, right click on location, and select "what's here".

*Note: the latitude/longitude required above is not the directional degrees, minutes, and seconds provided on a site legal description to define property boundaries.*

**C) MAP (Attachment) If no map is submitted, the application cannot be submitted.**

**Map:** Attach a map that indicates the site location and that CLEARLY shows the boundaries of the area that will be disturbed. A vicinity map is not adequate for this purpose.

**D) LEGAL DESCRIPTION - only for Subdivisions**

**Legal description:** If subdivided, provide the legal description below, or indicate that it is not applicable (**do not** supply Township/Range/Section or metes and bounds description of site)

Subdivision(s): \_\_\_\_\_ Lot(s): \_\_\_\_\_ Block(s) \_\_\_\_\_

OR  Not applicable (site has not been subdivided)

**E) AREA OF CONSTRUCTION SITE - SEE PAGE 1 - WILL DETERMINE FEE**

Provide both the total area of the construction site, and the area that will undergo disturbance, in acres.

Total area of project disturbance site (acres): \_\_\_\_\_

**Note:** aside from clearing, grading and excavation activities, disturbed areas also include areas receiving overburden (e.g., stockpiles), demolition areas, and areas with heavy equipment/vehicle traffic and storage that disturb existing vegetative cover.

Part of Larger Common Plan of Development or Sale, (i.e., total, including all phases, filings, lots, and infrastructure not covered by this application)

**F) NATURE OF CONSTRUCTION ACTIVITY**

Check the appropriate box(es) or provide a brief description that indicates the general nature of the construction activities. (The full description of activities must be included in the Stormwater Management Plan.)

Commercial Development

Residential Development

Highway and Transportation Development

Pipeline and Utilities (including natural gas, electricity, water, and communications)

Oil and Gas Exploration and Well Pad Development

Non-structural and other development (i.e. parks, trails, stream realignment, bank stabilization, demolition, etc.)

**G) ANTICIPATED CONSTRUCTION SCHEDULE**

Construction Start Date: \_\_\_\_\_ Final Stabilization Date: \_\_\_\_\_

- *Construction Start Date* - This is the day you expect to begin ground disturbing activities, including grubbing, stockpiling, excavating, demolition, and grading activities.
- *Final Stabilization Date* - in terms of permit coverage, this is when the site is finally stabilized. This means that all ground surface disturbing activities at the site have been completed, and all disturbed areas have been either built on, paved, or a uniform vegetative cover has been established with an individual plant density of at least 70 percent of pre-disturbance levels. **Permit coverage must be maintained until the site is finally stabilized. Even if you are only doing one part of the project, the estimated final stabilization date must be for the overall project.** If permit coverage is still required once your part is completed, the permit certification may be transferred or reassigned to a new responsible entity(s).

**H) RECEIVING WATERS (If discharge is to a ditch or storm sewer, include the name of the ultimate receiving waters)**

Immediate Receiving Water(s): \_\_\_\_\_

Ultimate Receiving Water(s): \_\_\_\_\_

Identify the receiving water of the stormwater from your site. Receiving waters are any waters of the State of Colorado. This includes all water courses, even if they are usually dry. If stormwater from the construction site enters a ditch or storm sewer system, identify that system and indicate the ultimate receiving water for the ditch or storm sewer. **Note:** a stormwater discharge permit does not allow a discharge into a ditch or storm sewer system without the approval of the owner/operator of that system.

**I) SIGNATURE PAGE**

1. You may print and sign this document and mail the hard copy to the State along with required documents (address on page one).

**2. Electronic Submission Signature**

You may choose to submit your application electronically, along with required attachments. To do so, click the SUBMIT button below which will direct you, via e-mail, to sign the document electronically using the DocuSign Electronic Signature process. Once complete, you will receive via e-mail, an electronically stamped Adobe pdf of this application. Print the signature page from the electronically stamped pdf, sign it and mail it to the WQCD Permits Section to complete the application process (address is on page one of the application).

- The Division encourages use of the electronic submission of the application and electronic signature. This method meets signature requirements as required by the State of Colorado.
- The ink signed copy of the electronically stamped pdf signature page is also required to meet Federal EPA Requirements.
- Processing of the application will begin with the receipt of the valid electronic signature.

**STORMWATER MANAGEMENT PLAN CERTIFICATION**

By checking this box "I certify under penalty of law that a complete Stormwater Management Plan, as described in the stormwater management plan guidance, has been pre-pared for my activity. Based on my inquiry of the person or persons who manage the system, or those persons directly responsible for gathering the information, the Stormwater Management Plan is, to the best of my knowledge and belief, true, accurate, and complete. I am aware that there are significant penalties for falsely certifying the completion of said SWMP, including the possibility of fine and imprisonment for knowing violations."

"I certify under penalty of law that this document and all attachments were prepared under my direction or supervision in accordance with a system designed to assure that qualified personnel properly gather and evaluate the information submitted. Based on my inquiry of the person or persons who manage the system, or those persons directly responsible for gathering the information, the information submitted is to the best of my knowledge and belief, true, accurate and complete. I am aware that there are significant penalties for submitting false information, including the possibility of fine and imprisonment for knowing violations."

"I understand that submittal of this application is for coverage under the State of Colorado General Permit for Stormwater Discharges Associated with Construction Activity for the entirety of the construction site/project described and applied for, until such time as the application is amended or the certification is transferred, inactivated, or expired." [Reg 61.4(1)(h)]

For DocuSign

Electronic Signature \_\_\_\_\_ Ink Signature \_\_\_\_\_ Date: \_\_\_\_\_

Signature of Legally Responsible Person or Authorized Agent (submission must include original signature)

\_\_\_\_\_  
Name (printed)

\_\_\_\_\_  
Title

**Signature:** The applicant must be either the owner and operator of the construction site. Refer to Part B of the instructions for additional information.

The application must be signed by the applicant to be considered complete. In all cases, it shall be signed as follows:

(Regulation 61.4 (1e))

- In the case of corporations, by the responsible corporate officer is responsible for the overall operation of the facility from which the discharge described in the form originates
- In the case of a partnership, by a general partner.
- In the case of a sole proprietorship, by the proprietor.
- In the case of a municipal, state, or other public facility, by either a principal executive officer, ranking elected official, (a principal executive officer has responsibility for the overall operation of the facility from which the discharge originates).

**3rd Party Preparer:** If this form was prepared by an authorized agent on behalf of the Permittee, please complete the field below.

\_\_\_\_\_  
Preparer Name (printed)

\_\_\_\_\_  
Email Address

**DO NOT INCLUDE A COPY OF THE STORMWATER MANAGEMENT PLAN  
DO NOT INCLUDE PAYMENT—AN INVOICE WILL BE SENT AFTER THE CERTIFICATION IS ISSUED.**

**SYSTEM (CDPS) CHECKLIST**  
**Operation & Maintenance Inspection Record**

The following inspection records are to be used at each bi-monthly stormwater management system inspection and after any precipitation or snowmelt event that causes surface runoff. As a result of these inspections, the SWMP may need to be revised. The inspection records and revised SWMP shall be made available to the division upon request. If the construction activity lasts more than 12 months, a copy of the inspection records and revised SWMP shall be sent to the division by May 1 of each year covering April 1 to March 31.

Action: \_\_\_\_\_ Project Type: \_\_\_\_\_ Zip Code: \_\_\_\_\_

Project Name: \_\_\_\_\_ Subdivision: \_\_\_\_\_

Address/Location: \_\_\_\_\_ Assigned Inspector: \_\_\_\_\_

Action Date: \_\_\_\_\_ Date Next Routine: \_\_\_\_\_ Date Next Follow-up: \_\_\_\_\_

Owner: \_\_\_\_\_ Owner Phone: \_\_\_\_\_ Stage of Construction: \_\_\_\_\_

Rep. Name: \_\_\_\_\_ Rep. Phone: \_\_\_\_\_ Inspected By: \_\_\_\_\_

	Items	Is Used	Maint. Required	Remarks / Actions Necessary
1	<b>Check Dam</b> <ul style="list-style-type: none"> <li>➤ Has accumulated sediment and debris been removed per maintenance requirements?</li> </ul>	No	No	
2	<b>Erosion Control Blanket</b> <ul style="list-style-type: none"> <li>➤ Is the erosion control blanket fabric damaged, loose, or in need of repair?</li> </ul>	No	No	
3	<b>Inlet Protection</b> <ul style="list-style-type: none"> <li>➤ Is the inlet protection damaged, ineffective or in need of repairs?</li> <li>➤ Does sediment remain in inlets?</li> </ul>	No	No No	
4	<b>Mulching</b> <ul style="list-style-type: none"> <li>➤ Uneven mulch distribution on disturbed areas?</li> <li>➤ Is the mulch application rate inadequate?</li> <li>➤ Any evidence of mulch being blown or washed away?</li> <li>➤ Do areas require additional mulching?</li> </ul>	No	No No No No	
5	<b>Sediment / Basin Trap</b> <ul style="list-style-type: none"> <li>➤ Is the sediment basin improperly constructed or inoperable?</li> <li>➤ Is there sediment and/or debris in the basin?</li> </ul>	No	No No	
6	<b>Silt Fence</b> <ul style="list-style-type: none"> <li>➤ Is the silt fence damaged, collapsed, un-trenched or ineffective?</li> <li>➤ Is the excess sediment against the barrier?</li> <li>➤ Is the silt fence improperly located?</li> </ul>	No	No No No	
7	<b>Slope Drain</b> <ul style="list-style-type: none"> <li>➤ Is water bypassing or undercutting the inlet or pipe?</li> <li>➤ Is there any evidence of erosion?</li> </ul>	No	No No	
8	<b>Straw Bale Barrier</b> <ul style="list-style-type: none"> <li>➤ Are the straw bales damaged, ineffective or un-trenched?</li> <li>➤ Is there excess sediment against the barrier?</li> <li>➤ Are the bales installed and positioned incorrectly?</li> </ul>	No	No No No	
9	<b>Surface Roughening</b> <ul style="list-style-type: none"> <li>➤ Is the surface roughening inconsistent on slopes?</li> <li>➤ Is there any evidence of surface roughening erosion?</li> </ul>	No	No No	
10	<b>Seeding</b> <ul style="list-style-type: none"> <li>➤ Are the seedbeds unprotected?</li> <li>➤ Has any erosion occurred in the seeded area?</li> <li>➤ Any evidence of vehicle tracking on seeded area?</li> </ul>	No	No No No	
11	<b>Temporary Swales</b> <ul style="list-style-type: none"> <li>➤ Has any sediment or debris been deposited within the swales?</li> <li>➤ Have the slopes of the swale eroded or has damage occurred to the lining?</li> <li>➤ Are the swales improperly located?</li> </ul>	No	No No No	
12	<b>Vehicle Tracking</b> <ul style="list-style-type: none"> <li>➤ Is gravel surface clogged with mud or sediment?</li> <li>➤ Is the gravel surface sinking into the ground?</li> <li>➤ Has sediment been tracked onto any roads?</li> <li>➤ Is inlet protection missing around curb inlets near construction entrance?</li> </ul>	No	No No No No	
13	<b>Diversion Structure</b> <ul style="list-style-type: none"> <li>➤ Has the structure been damaged or show signs of erosion?</li> <li>➤ Is the structure properly located?</li> </ul>	No	No No	

<b>14</b>	<b>Outlet Protection</b> ➤ Is erosion taking place?	No	No	
<b>15</b>	<b>Rough-Cut Street Control</b> ➤ Have structures been properly located and installed? ➤ Is there excess sediment against the structures?	No	No No	
<b>16</b>	<b>Concrete Washout</b> ➤ Has material been removed per maintenance requirements? ➤ Does structure have adequate signage? ➤ Is there adequate tracking-pad material for access, if necessary? ➤ Is there adequate protection around the structure?	No	No No No No	
<b>17</b>	<b>Erosion Logs</b> ➤ Are the erosion logs damaged, collapsed, or ineffective? ➤ Is there excess sediment against the barrier? ➤ Are the erosion logs improperly located?	No	No No No	
<b>18</b>	<b>GEC Management</b> ➤ Is the GEC notebook located on site? ➤ Are changes to the GEC documents noted and approved? ➤ Are the inspection reports retained on-site? ➤ Are corrective actions from the last inspection completed?	No	No No No No	
<b>19</b>	<b>Materials and Pollution</b> ➤ Are stockpiles being managed properly? ➤ Are materials being managed properly? ➤ Is solid waste and trash being managed properly? ➤ Is street sweeping being managed properly? ➤ Are the sanitary facilities being managed properly? ➤ Are the vehicles and equipment being managed properly? ➤ Are there other materials or pollution issues being properly maintained?	No	No No No No No No No No	

Project Status: \_\_\_\_\_ Const. Start Date: \_\_\_\_\_ Size of Disturbance (acres): \_\_\_\_\_

Additional Comments:

**COMPLETED OPERATION AND  
MAINTENANCE INSPECTION RECORDS**

**STANDARD BMP DETAILS**  
**W/ INSTALLATION AND MAINTENANCE REQUIREMENTS**



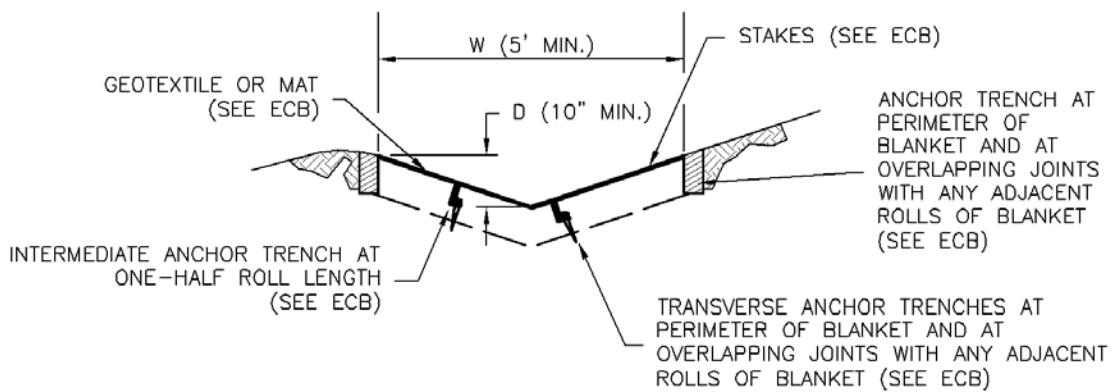
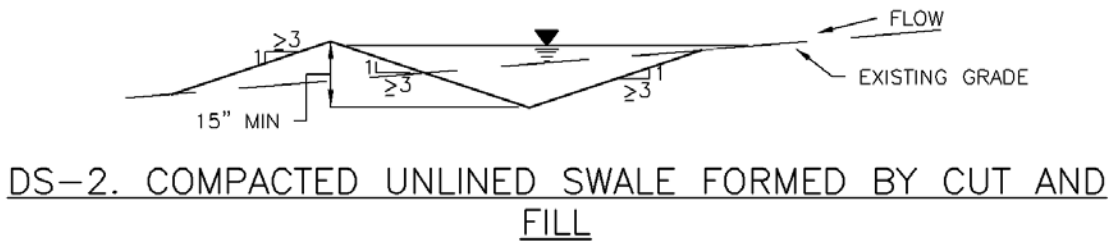
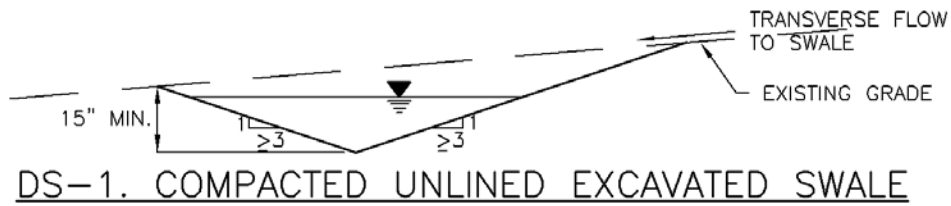
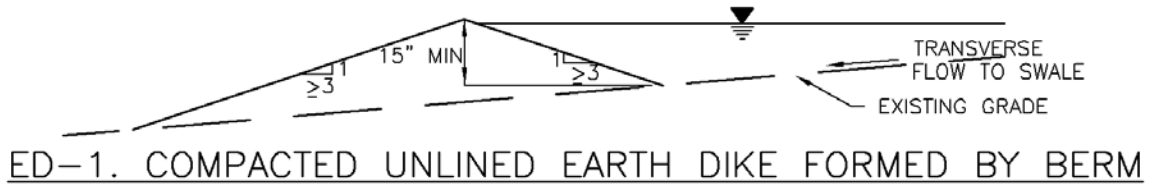
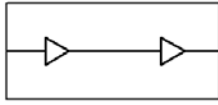

# EC-10 Earth Dikes and Drainage Swales (ED/DS)

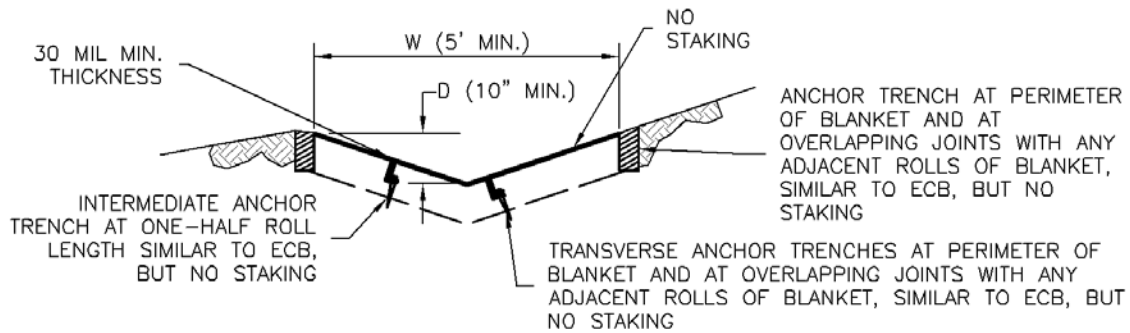

DS-4. SYNTHETIC LINED SWALE

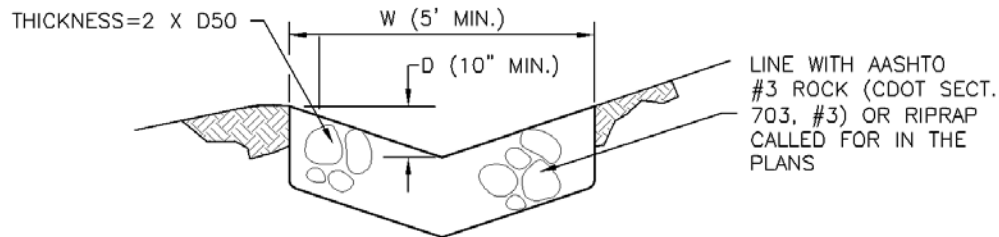

DS-5. RIPRAP LINED SWALE

## EARTH DIKE AND DRAINAGE SWALE INSTALLATION NOTES

1. SEE SITE PLAN FOR:
  - LOCATION OF DIVERSION SWALE
  - TYPE OF SWALE (UNLINED, COMPACTED AND/OR LINED).
  - LENGTH OF EACH SWALE.
  - DEPTH, D, AND WIDTH, W DIMENSIONS.
  - FOR ECB/TRM LINED DITCH, SEE ECB DETAIL.
  - FOR RIPRAP LINED DITCH, SIZE OF RIPRAP, D50.
2. SEE DRAINAGE PLANS FOR DETAILS OF PERMANENT CONVEYANCE FACILITIES AND/OR DIVERSION SWALES EXCEEDING 2-YEAR FLOW RATE OR 10 CFS.
3. EARTH DIKES AND SWALES INDICATED ON SWMP PLAN SHALL BE INSTALLED PRIOR TO LAND-DISTURBING ACTIVITIES IN PROXIMITY.
4. EMBANKMENT IS TO BE COMPACTED TO 90% OF MAXIMUM DENSITY AND WITHIN 2% OF OPTIMUM MOISTURE CONTENT ACCORDING TO ASTM D698.
5. SWALES ARE TO DRAIN TO A SEDIMENT CONTROL BMP.
6. FOR LINED DITCHES, INSTALLATION OF ECB/TRM SHALL CONFORM TO THE REQUIREMENTS OF THE ECB DETAIL.
7. WHEN CONSTRUCTION TRAFFIC MUST CROSS A DIVERSION SWALE, INSTALL A TEMPORARY CULVERT WITH A MINIMUM DIAMETER OF 12 INCHES.

## EARTH DIKE AND DRAINAGE SWALE MAINTENANCE NOTES

1. INSPECT BMPs EACH WORKDAY, AND MAINTAIN THEM IN EFFECTIVE OPERATING CONDITION. MAINTENANCE OF BMPs SHOULD BE PROACTIVE, NOT REACTIVE. INSPECT BMPs AS SOON AS POSSIBLE (AND ALWAYS WITHIN 24 HOURS) FOLLOWING A STORM THAT CAUSES SURFACE EROSION, AND PERFORM NECESSARY MAINTENANCE.
2. FREQUENT OBSERVATIONS AND MAINTENANCE ARE NECESSARY TO MAINTAIN BMPs IN EFFECTIVE OPERATING CONDITION. INSPECTIONS AND CORRECTIVE MEASURES SHOULD BE DOCUMENTED THOROUGHLY.
3. WHERE BMPs HAVE FAILED, REPAIR OR REPLACEMENT SHOULD BE INITIATED UPON DISCOVERY OF THE FAILURE.
4. SWALES SHALL REMAIN IN PLACE UNTIL THE END OF CONSTRUCTION; IF APPROVED BY LOCAL JURISDICTION, SWALES MAY BE LEFT IN PLACE.
5. WHEN A SWALE IS REMOVED, THE DISTURBED AREA SHALL BE COVERED WITH TOPSOIL, SEEDED AND MULCHED OR OTHERWISE STABILIZED IN A MANNER APPROVED BY LOCAL JURISDICTION.

(DETAIL ADAPTED FROM DOUGLAS COUNTY, COLORADO AND THE CITY OF COLORADO SPRINGS, COLORADO, NOT AVAILABLE IN AUTOCAD)

NOTE: MANY JURISDICTIONS HAVE BMP DETAILS THAT VARY FROM UDFCD STANDARD DETAILS. CONSULT WITH LOCAL JURISDICTIONS AS TO WHICH DETAIL SHOULD BE USED WHEN DIFFERENCES ARE NOTED.

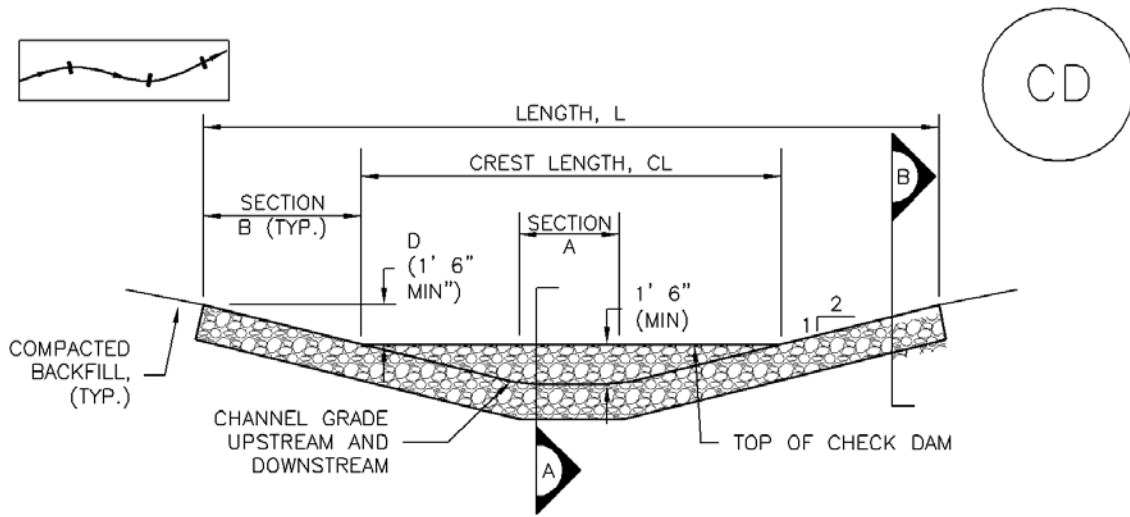

**CHECK DAM ELEVATION VIEW**

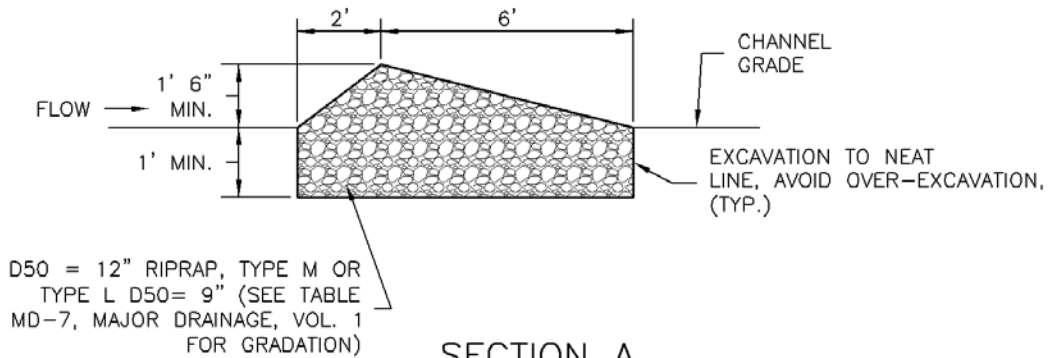

**SECTION A**

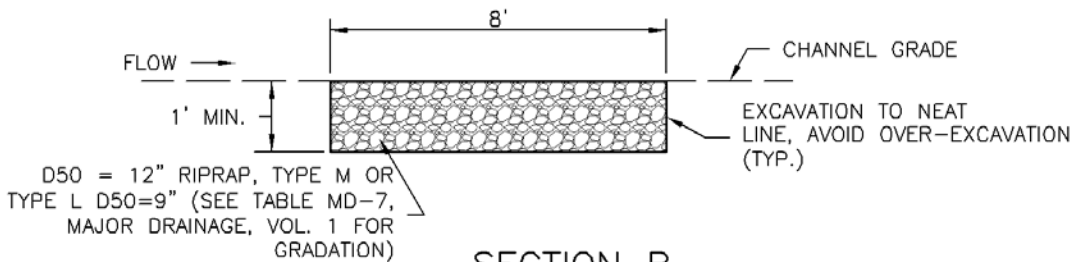

**SECTION B**

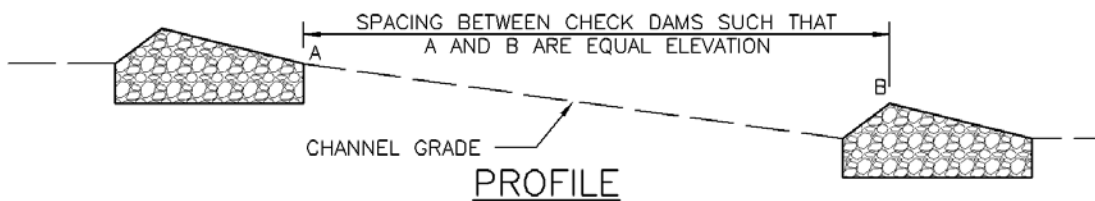

**PROFILE**

**CD-1. CHECK DAM**

CHECK DAM INSTALLATION NOTES

1. SEE PLAN VIEW FOR:
  - LOCATION OF CHECK DAMS.
  - CHECK DAM TYPE (CHECK DAM OR REINFORCED CHECK DAM).
  - LENGTH (L), CREST LENGTH (CL), AND DEPTH (D).
2. CHECK DAMS INDICATED ON INITIAL SWMP SHALL BE INSTALLED AFTER CONSTRUCTION FENCE, BUT PRIOR TO ANY UPSTREAM LAND DISTURBING ACTIVITIES.
3. RIPRAP UTILIZED FOR CHECK DAMS SHOULD BE OF APPROPRIATE SIZE FOR THE APPLICATION. TYPICAL TYPES OF RIPRAP USED FOR CHECK DAMS ARE TYPE M (D50 12") OR TYPE L (D50 9").
4. RIPRAP PAD SHALL BE TRENCHED INTO THE GROUND A MINIMUM OF 1'.
5. THE ENDS OF THE CHECK DAM SHALL BE A MINIMUM OF 1' 6" HIGHER THAN THE CENTER OF THE CHECK DAM.

CHECK DAM MAINTENANCE NOTES

1. INSPECT BMPs EACH WORKDAY, AND MAINTAIN THEM IN EFFECTIVE OPERATING CONDITION. MAINTENANCE OF BMPs SHOULD BE PROACTIVE, NOT REACTIVE. INSPECT BMPs AS SOON AS POSSIBLE (AND ALWAYS WITHIN 24 HOURS) FOLLOWING A STORM THAT CAUSES SURFACE EROSION, AND PERFORM NECESSARY MAINTENANCE.
2. FREQUENT OBSERVATIONS AND MAINTENANCE ARE NECESSARY TO MAINTAIN BMPs IN EFFECTIVE OPERATING CONDITION. INSPECTIONS AND CORRECTIVE MEASURES SHOULD BE DOCUMENTED THOROUGHLY.
3. WHERE BMPs HAVE FAILED, REPAIR OR REPLACEMENT SHOULD BE INITIATED UPON DISCOVERY OF THE FAILURE.
4. SEDIMENT ACCUMULATED UPSTREAM OF THE CHECK DAMS SHALL BE REMOVED WHEN THE SEDIMENT DEPTH IS WITHIN ½ OF THE HEIGHT OF THE CREST.
5. CHECK DAMS ARE TO REMAIN IN PLACE UNTIL THE UPSTREAM DISTURBED AREA IS STABILIZED AND APPROVED BY THE LOCAL JURISDICTION.
6. WHEN CHECK DAMS ARE REMOVED, EXCAVATIONS SHALL BE FILLED WITH SUITABLE COMPACTED BACKFILL. DISTURBED AREA SHALL BE SEEDED AND MULCHED AND COVERED WITH GEOTEXTILE OR OTHERWISE STABILIZED IN A MANNER APPROVED BY THE LOCAL JURISDICTION.

(DETAILS ADAPTED FROM DOUGLAS COUNTY, COLORADO, NOT AVAILABLE IN AUTOCAD)

NOTE: MANY JURISDICTIONS HAVE BMP DETAILS THAT VARY FROM UDFCD STANDARD DETAILS. CONSULT WITH LOCAL JURISDICTIONS AS TO WHICH DETAIL SHOULD BE USED WHEN DIFFERENCES ARE NOTED.

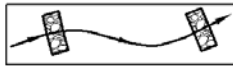

ALTERNATIVE TO STEPS ON BANKS ABOVE CREST:  
DEFORM GABIONS AS NECESSARY TO ALIGN TOP OF GABIONS  
WITH GROUND SURFACE: AVOID GAPS BETWEEN GABIONS

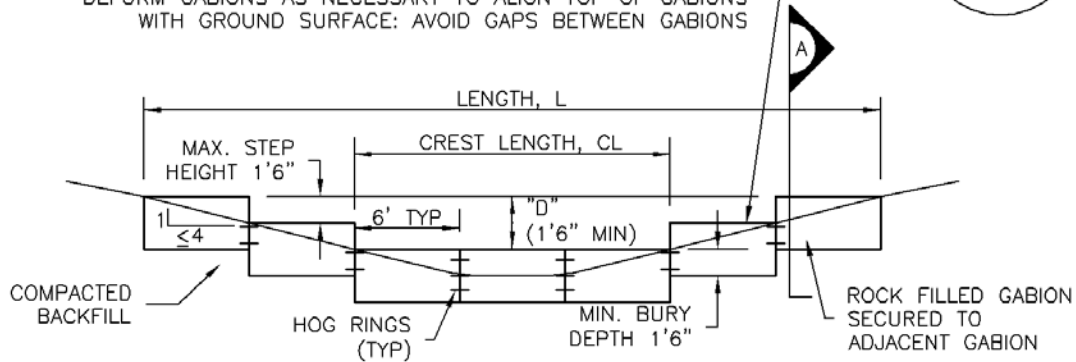

## REINFORCED CHECK DAM ELEVATION VIEW

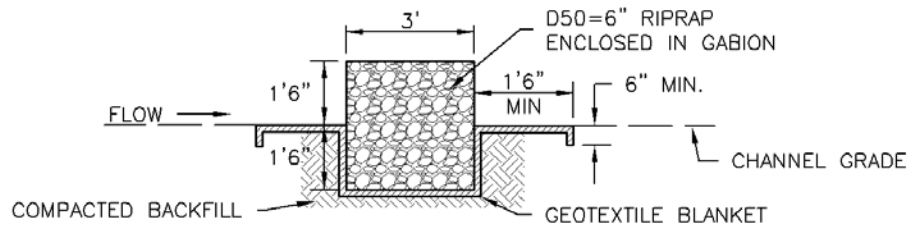

## SECTION A

### REINFORCED CHECK DAM INSTALLATION NOTES

1. SEE PLAN VIEW FOR:
  - LOCATIONS OF CHECK DAMS.
  - CHECK DAM TYPE (CHECK DAM OR REINFORCED CHECK DAM).
  - LENGTH (L), CREST LENGTH (CL), AND DEPTH (D).
2. CHECK DAMS INDICATED ON THE SWMP SHALL BE INSTALLED PRIOR TO AN UPSTREAM LAND-DISTURBING ACTIVITIES.
3. REINFORCED CHECK DAMS, GABIONS SHALL HAVE GALVANIZED TWISTED WIRE NETTING WITH A MAXIMUM OPENING DIMENSION OF  $4\frac{1}{2}$ " AND A MINIMUM WIRE THICKNESS OF 0.10". WIRE "HOG RINGS" AT 4" SPACING OR OTHER APPROVED MEANS SHALL BE USED AT ALL GABION SEAMS AND TO SECURE THE GABION TO THE ADJACENT SECTION.
4. THE CHECK DAM SHALL BE TRENCHED INTO THE GROUND A MINIMUM OF 1' 6".
5. GEOTEXTILE BLANKET SHALL BE PLACED IN THE REINFORCED CHECK DAM TRENCH EXTENDING A MINIMUM OF 1' 6" ON BOTH THE UPSTREAM AND DOWNSTREAM SIDES OF THE REINFORCED CHECK DAM.

## CD-2. REINFORCED CHECK DAM

REINFORCED CHECK DAM MAINTENANCE NOTES

1. INSPECT BMPs EACH WORKDAY, AND MAINTAIN THEM IN EFFECTIVE OPERATING CONDITION. MAINTENANCE OF BMPs SHOULD BE PROACTIVE, NOT REACTIVE. INSPECT BMPs AS SOON AS POSSIBLE (AND ALWAYS WITHIN 24 HOURS) FOLLOWING A STORM THAT CAUSES SURFACE EROSION, AND PERFORM NECESSARY MAINTENANCE.
2. FREQUENT OBSERVATIONS AND MAINTENANCE ARE NECESSARY TO MAINTAIN BMPs IN EFFECTIVE OPERATING CONDITION. INSPECTIONS AND CORRECTIVE MEASURES SHOULD BE DOCUMENTED THOROUGHLY.
3. WHERE BMPs HAVE FAILED, REPAIR OR REPLACEMENT SHOULD BE INITIATED UPON DISCOVERY OF THE FAILURE.
4. SEDIMENT ACCUMULATED UPSTREAM OF REINFORCED CHECK DAMS SHALL BE REMOVED AS NEEDED TO MAINTAIN THE EFFECTIVENESS OF BMP, TYPICALLY WHEN THE UPSTREAM SEDIMENT DEPTH IS WITHIN ½ THE HEIGHT OF THE CREST.
5. REPAIR OR REPLACE REINFORCED CHECK DAMS WHEN THERE ARE SIGNS OF DAMAGE SUCH AS HOLES IN THE GABION OR UNDERCUTTING.
6. REINFORCED CHECK DAMS ARE TO REMAIN IN PLACE UNTIL THE UPSTREAM DISTURBED AREA IS STABILIZED AND APPROVED BY THE LOCAL JURISDICTION.
7. WHEN REINFORCED CHECK DAMS ARE REMOVED, ALL DISTURBED AREAS SHALL BE COVERED WITH TOPSOIL, SEEDED AND MULCHED, AND COVERED WITH A GEOTEXTILE BLANKET, OR OTHERWISE STABILIZED AS APPROVED BY LOCAL JURISDICTION.

(DETAIL ADAPTED FROM DOUGLAS COUNTY, COLORADO AND CITY OF AURORA, COLORADO, NOT AVAILABLE IN AUTOCAD)

NOTE: MANY JURISDICTIONS HAVE BMP DETAILS THAT VARY FROM UDFCD STANDARD DETAILS. CONSULT WITH LOCAL JURISDICTIONS AS TO WHICH DETAIL SHOULD BE USED WHEN DIFFERENCES ARE NOTED.

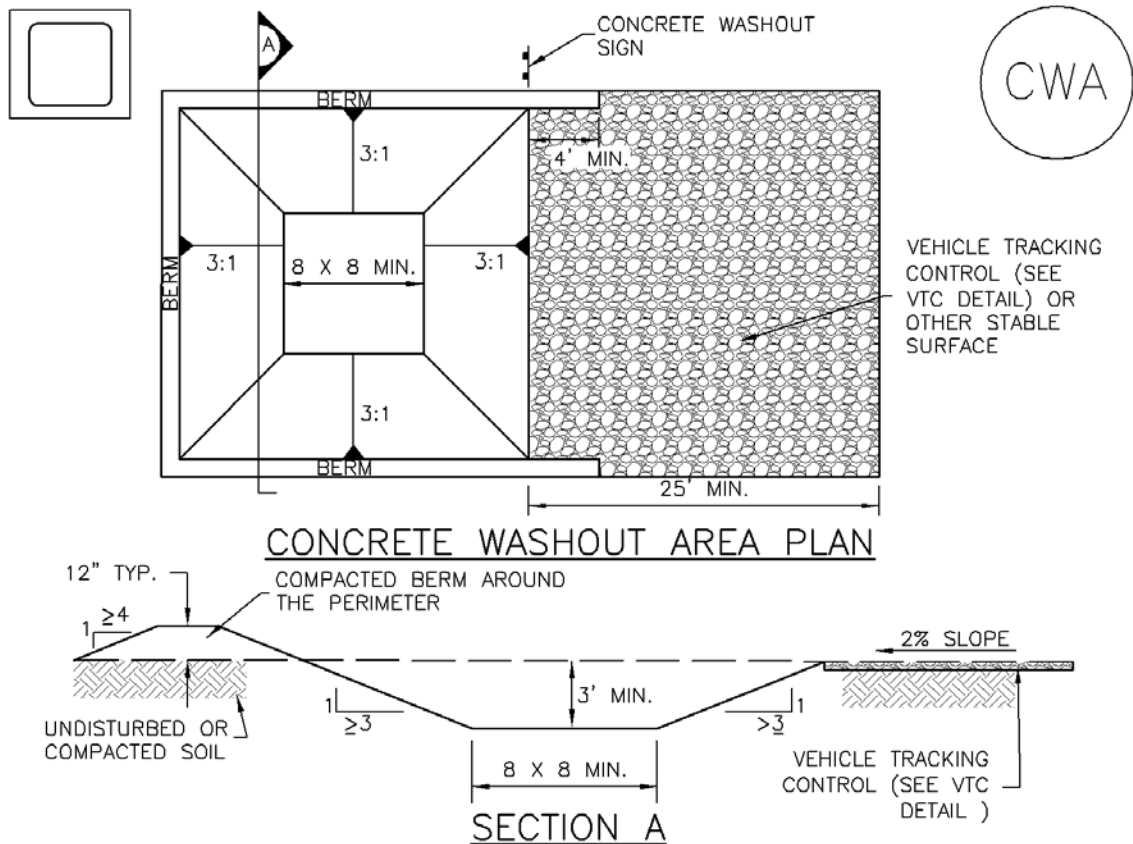

## CWA-1. CONCRETE WASHOUT AREA

### CWA INSTALLATION NOTES

1. SEE PLAN VIEW FOR:  
-CWA INSTALLATION LOCATION.
2. DO NOT LOCATE AN UNLINED CWA WITHIN 400' OF ANY NATURAL DRAINAGE PATHWAY OR WATERBODY. DO NOT LOCATE WITHIN 1,000' OF ANY WELLS OR DRINKING WATER SOURCES. IF SITE CONSTRAINTS MAKE THIS INFEASIBLE, OR IF HIGHLY PERMEABLE SOILS EXIST ON SITE, THE CWA MUST BE INSTALLED WITH AN IMPERMEABLE LINER (16 MIL MIN. THICKNESS) OR SURFACE STORAGE ALTERNATIVES USING PREFABRICATED CONCRETE WASHOUT DEVICES OR A LINED ABOVE GROUND STORAGE ARE SHOULD BE USED.
3. THE CWA SHALL BE INSTALLED PRIOR TO CONCRETE PLACEMENT ON SITE.
4. CWA SHALL INCLUDE A FLAT SUBSURFACE PIT THAT IS AT LEAST 8' BY 8' SLOPES LEADING OUT OF THE SUBSURFACE PIT SHALL BE 3:1 OR FLATTER. THE PIT SHALL BE AT LEAST 3' DEEP.
5. BERM SURROUNDING SIDES AND BACK OF THE CWA SHALL HAVE MINIMUM HEIGHT OF 1'.
6. VEHICLE TRACKING PAD SHALL BE SLOPED 2% TOWARDS THE CWA.
7. SIGNS SHALL BE PLACED AT THE CONSTRUCTION ENTRANCE, AT THE CWA, AND ELSEWHERE AS NECESSARY TO CLEARLY INDICATE THE LOCATION OF THE CWA TO OPERATORS OF CONCRETE TRUCKS AND PUMP RIGS.
8. USE EXCAVATED MATERIAL FOR PERIMETER BERM CONSTRUCTION.



CWA MAINTENANCE NOTES

1. INSPECT BMPs EACH WORKDAY, AND MAINTAIN THEM IN EFFECTIVE OPERATING CONDITION. MAINTENANCE OF BMPs SHOULD BE PROACTIVE, NOT REACTIVE. INSPECT BMPs AS SOON AS POSSIBLE (AND ALWAYS WITHIN 24 HOURS) FOLLOWING A STORM THAT CAUSES SURFACE EROSION, AND PERFORM NECESSARY MAINTENANCE.

2. FREQUENT OBSERVATIONS AND MAINTENANCE ARE NECESSARY TO MAINTAIN BMPs IN EFFECTIVE OPERATING CONDITION. INSPECTIONS AND CORRECTIVE MEASURES SHOULD BE DOCUMENTED THOROUGHLY.

3. WHERE BMPs HAVE FAILED, REPAIR OR REPLACEMENT SHOULD BE INITIATED UPON DISCOVERY OF THE FAILURE.

4. THE CWA SHALL BE REPAIRED, CLEANED, OR ENLARGED AS NECESSARY TO MAINTAIN CAPACITY FOR CONCRETE WASTE. CONCRETE MATERIALS, ACCUMULATED IN PIT, SHALL BE REMOVED ONCE THE MATERIALS HAVE REACHED A DEPTH OF 2'.

5. CONCRETE WASHOUT WATER, WASTED PIECES OF CONCRETE AND ALL OTHER DEBRIS IN THE SUBSURFACE PIT SHALL BE TRANSPORTED FROM THE JOB SITE IN A WATER-TIGHT CONTAINER AND DISPOSED OF PROPERLY.

6. THE CWA SHALL REMAIN IN PLACE UNTIL ALL CONCRETE FOR THE PROJECT IS PLACED.

7. WHEN THE CWA IS REMOVED, COVER THE DISTURBED AREA WITH TOP SOIL, SEED AND MULCH OR OTHERWISE STABILIZED IN A MANNER APPROVED BY THE LOCAL JURISDICTION.

(DETAIL ADAPTED FROM DOUGLAS COUNTY, COLORADO AND THE CITY OF PARKER, COLORADO, NOT AVAILABLE IN AUTOCAD).

NOTE: MANY JURISDICTIONS HAVE BMP DETAILS THAT VARY FROM UDFCD STANDARD DETAILS. CONSULT WITH LOCAL JURISDICTIONS AS TO WHICH DETAIL SHOULD BE USED WHEN DIFFERENCES ARE NOTED.

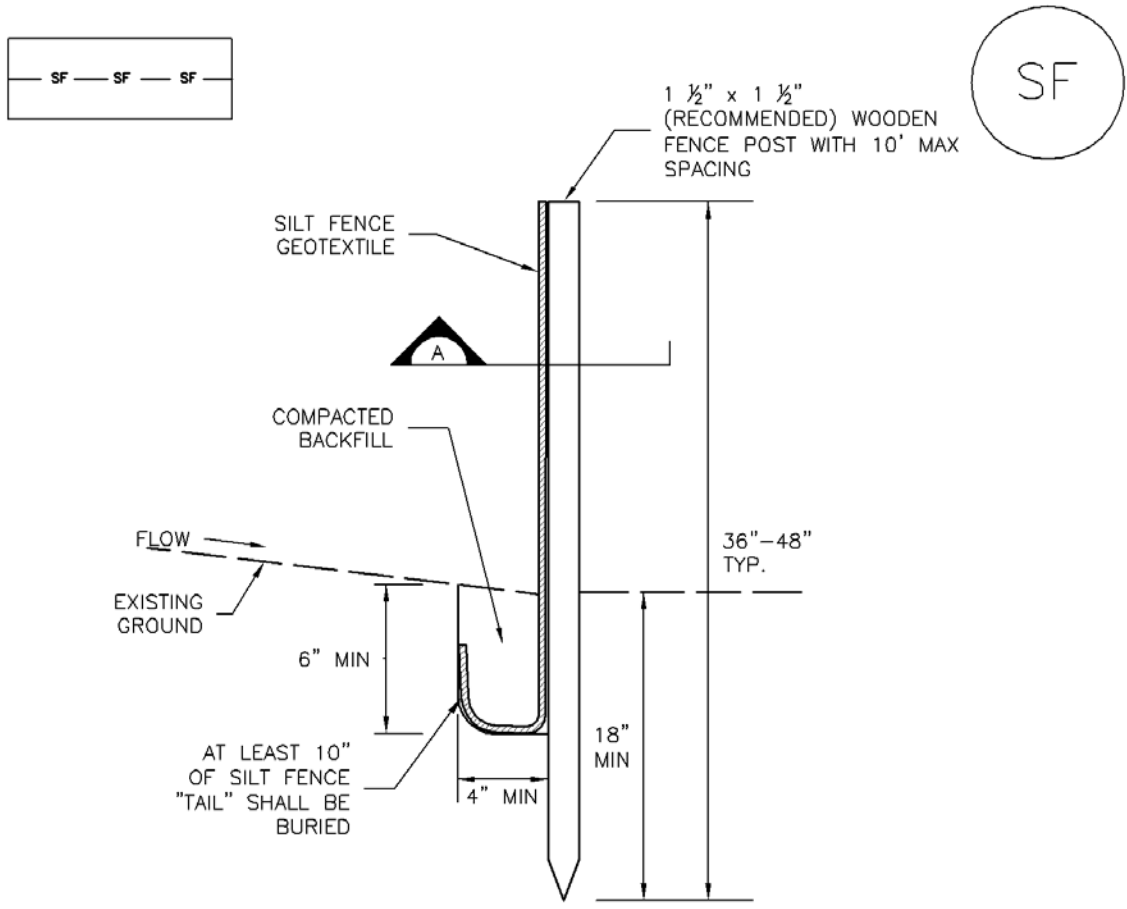

SILT FENCE

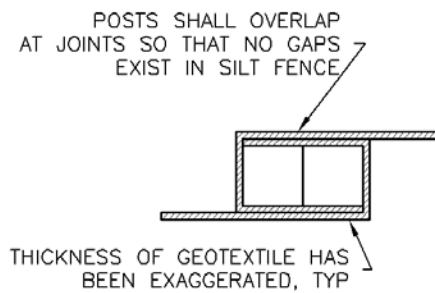
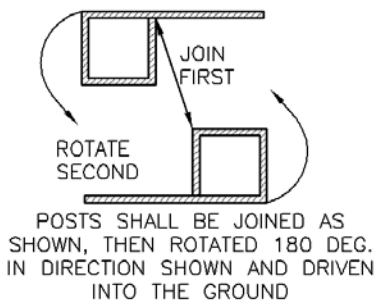

SECTION A

SF-1. SILT FENCE

SILT FENCE INSTALLATION NOTES

1. SILT FENCE MUST BE PLACED AWAY FROM THE TOE OF THE SLOPE TO ALLOW FOR WATER PONDING. SILT FENCE AT THE TOE OF A SLOPE SHOULD BE INSTALLED IN A FLAT LOCATION AT LEAST SEVERAL FEET (2-5 FT) FROM THE TOE OF THE SLOPE TO ALLOW ROOM FOR PONDING AND DEPOSITION.
2. A UNIFORM 6" X 4" ANCHOR TRENCH SHALL BE EXCAVATED USING TRENCHER OR SILT FENCE INSTALLATION DEVICE. NO ROAD GRADERS, BACKHOES, OR SIMILAR EQUIPMENT SHALL BE USED.
3. COMPACT ANCHOR TRENCH BY HAND WITH A "JUMPING JACK" OR BY WHEEL ROLLING. COMPACTION SHALL BE SUCH THAT SILT FENCE RESISTS BEING PULLED OUT OF ANCHOR TRENCH BY HAND.
4. SILT FENCE SHALL BE PULLED TIGHT AS IT IS ANCHORED TO THE STAKES. THERE SHOULD BE NO NOTICEABLE SAG BETWEEN STAKES AFTER IT HAS BEEN ANCHORED TO THE STAKES.
5. SILT FENCE FABRIC SHALL BE ANCHORED TO THE STAKES USING 1" HEAVY DUTY STAPLES OR NAILS WITH 1" HEADS. STAPLES AND NAILS SHOULD BE PLACED 3" ALONG THE FABRIC DOWN THE STAKE.
6. AT THE END OF A RUN OF SILT FENCE ALONG A CONTOUR, THE SILT FENCE SHOULD BE TURNED PERPENDICULAR TO THE CONTOUR TO CREATE A "J-HOOK." THE "J-HOOK" EXTENDING PERPENDICULAR TO THE CONTOUR SHOULD BE OF SUFFICIENT LENGTH TO KEEP RUNOFF FROM FLOWING AROUND THE END OF THE SILT FENCE (TYPICALLY 10' - 20').
7. SILT FENCE SHALL BE INSTALLED PRIOR TO ANY LAND DISTURBING ACTIVITIES.

SILT FENCE MAINTENANCE NOTES

1. INSPECT BMPs EACH WORKDAY, AND MAINTAIN THEM IN EFFECTIVE OPERATING CONDITION. MAINTENANCE OF BMPs SHOULD BE PROACTIVE, NOT REACTIVE. INSPECT BMPs AS SOON AS POSSIBLE (AND ALWAYS WITHIN 24 HOURS) FOLLOWING A STORM THAT CAUSES SURFACE EROSION, AND PERFORM NECESSARY MAINTENANCE.
2. FREQUENT OBSERVATIONS AND MAINTENANCE ARE NECESSARY TO MAINTAIN BMPs IN EFFECTIVE OPERATING CONDITION. INSPECTIONS AND CORRECTIVE MEASURES SHOULD BE DOCUMENTED THOROUGHLY.
3. WHERE BMPs HAVE FAILED, REPAIR OR REPLACEMENT SHOULD BE INITIATED UPON DISCOVERY OF THE FAILURE.
4. SEDIMENT ACCUMULATED UPSTREAM OF THE SILT FENCE SHALL BE REMOVED AS NEEDED TO MAINTAIN THE FUNCTIONALITY OF THE BMP, TYPICALLY WHEN DEPTH OF ACCUMULATED SEDIMENTS IS APPROXIMATELY 6".
5. REPAIR OR REPLACE SILT FENCE WHEN THERE ARE SIGNS OF WEAR, SUCH AS SAGGING, TEARING, OR COLLAPSE.
6. SILT FENCE IS TO REMAIN IN PLACE UNTIL THE UPSTREAM DISTURBED AREA IS STABILIZED AND APPROVED BY THE LOCAL JURISDICTION, OR IS REPLACED BY AN EQUIVALENT PERIMETER SEDIMENT CONTROL BMP.
7. WHEN SILT FENCE IS REMOVED, ALL DISTURBED AREAS SHALL BE COVERED WITH TOPSOIL, SEEDED AND MULCHED OR OTHERWISE STABILIZED AS APPROVED BY LOCAL JURISDICTION.

(DETAIL ADAPTED FROM TOWN OF PARKER, COLORADO AND CITY OF AURORA, NOT AVAILABLE IN AUTOCAD)

NOTE: MANY JURISDICTIONS HAVE BMP DETAILS THAT VARY FROM UDFCD STANDARD DETAILS. CONSULT WITH LOCAL JURISDICTIONS AS TO WHICH DETAIL SHOULD BE USED WHEN DIFFERENCES ARE NOTED.

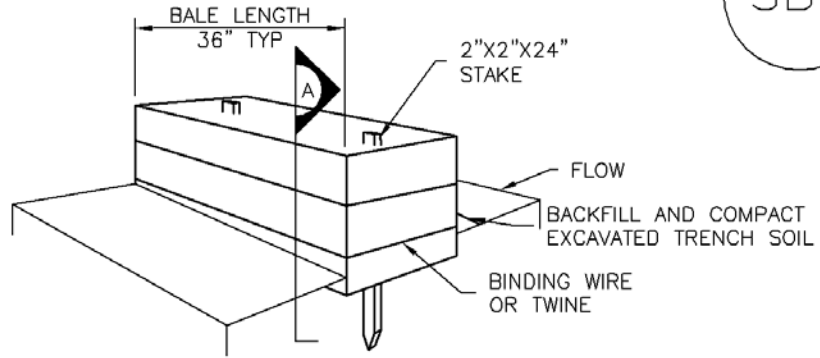
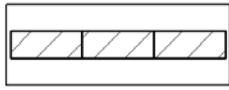

STRAW BALE

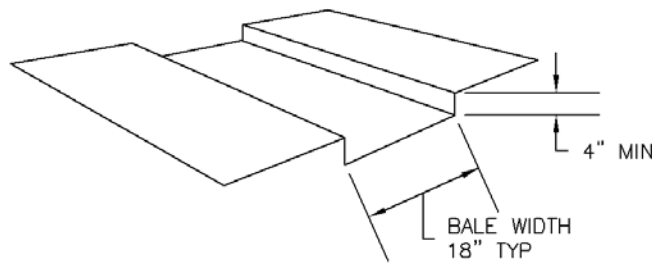

TRENCH FOR STRAW BALE

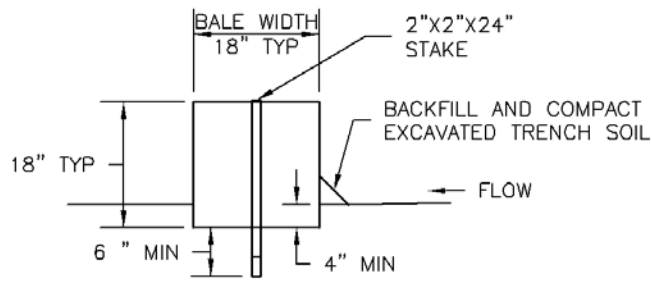

SECTION A

SBB-1. STRAW BALE

## STRAW BALE INSTALLATION NOTES

1. SEE PLAN VIEW FOR:  
-LOCATION(S) OF STRAW BALES.
2. STRAW BALES SHALL CONSIST OF CERTIFIED WEED FREE STRAW OR HAY. LOCAL JURISDICTIONS MAY REQUIRE PROOF THAT BALES ARE WEED FREE.
3. STRAW BALES SHALL CONSIST OF APPROXIMATELY 5 CUBIC FEET OF STRAW OR HAY AND WEIGH NOT LESS THAN 35 POUNDS.
4. WHEN STRAW BALES ARE USED IN SERIES AS A BARRIER, THE END OF EACH BALE SHALL BE TIGHTLY ABUTTING ONE ANOTHER.
5. STRAW BALE DIMENSIONS SHALL BE APPROXIMATELY 36"X18"X18".
6. A UNIFORM ANCHOR TRENCH SHALL BE EXCAVATED TO A DEPTH OF 4". STRAW BALES SHALL BE PLACED SO THAT BINDING TWINE IS ENCOMPASSING THE VERTICAL SIDES OF THE BALE(S). ALL EXCAVATED SOIL SHALL BE PLACED ON THE UPHILL SIDE OF THE STRAW BALE(S) AND COMPACTED.
7. TWO (2) WOODEN STAKES SHALL BE USED TO HOLD EACH BALE IN PLACE. WOODEN STAKES SHALL BE 2"X2"X24". WOODEN STAKES SHALL BE DRIVEN 6" INTO THE GROUND.

## STRAW BALE MAINTENANCE NOTES

1. INSPECT BMPs EACH WORKDAY, AND MAINTAIN THEM IN EFFECTIVE OPERATING CONDITION. MAINTENANCE OF BMPs SHOULD BE PROACTIVE, NOT REACTIVE. INSPECT BMPs AS SOON AS POSSIBLE (AND ALWAYS WITHIN 24 HOURS) FOLLOWING A STORM THAT CAUSES SURFACE EROSION, AND PERFORM NECESSARY MAINTENANCE.
2. FREQUENT OBSERVATIONS AND MAINTENANCE ARE NECESSARY TO MAINTAIN BMPs IN EFFECTIVE OPERATING CONDITION. INSPECTIONS AND CORRECTIVE MEASURES SHOULD BE DOCUMENTED THOROUGHLY.
3. WHERE BMPs HAVE FAILED, REPAIR OR REPLACEMENT SHOULD BE INITIATED UPON DISCOVERY OF THE FAILURE.
4. STRAW BALES SHALL BE REPLACED IF THEY BECOME HEAVILY SOILED, ROTTEN, OR DAMAGED BEYOND REPAIR.
5. SEDIMENT ACCUMULATED UPSTREAM OF STRAW BALE BARRIER SHALL BE REMOVED AS NEEDED TO MAINTAIN FUNCTIONALITY OF THE BMP, TYPICALLY WHEN DEPTH OF ACCUMULATED SEDIMENTS IS APPROXIMATELY  $\frac{1}{4}$  OF THE HEIGHT OF THE STRAW BALE BARRIER.
6. STRAW BALES ARE TO REMAIN IN PLACE UNTIL THE UPSTREAM DISTURBED AREA IS STABILIZED AND APPROVED BY THE LOCAL JURISDICTION.
7. WHEN STRAW BALES ARE REMOVED, ALL DISTURBED AREAS SHALL BE COVERED WITH TOPSOIL, SEEDED AND MULCHED OR OTHERWISE STABILIZED AS APPROVED BY LOCAL JURISDICTION.

(DETAILS ADAPTED FROM TOWN OF PARKER, COLORADO, NOT AVAILABLE IN AUTOCAD)

NOTE: MANY JURISDICTIONS HAVE BMP DETAILS THAT VARY FROM UDFCD STANDARD DETAILS. CONSULT WITH LOCAL JURISDICTIONS AS TO WHICH DETAIL SHOULD BE USED WHEN DIFFERENCES ARE NOTED.

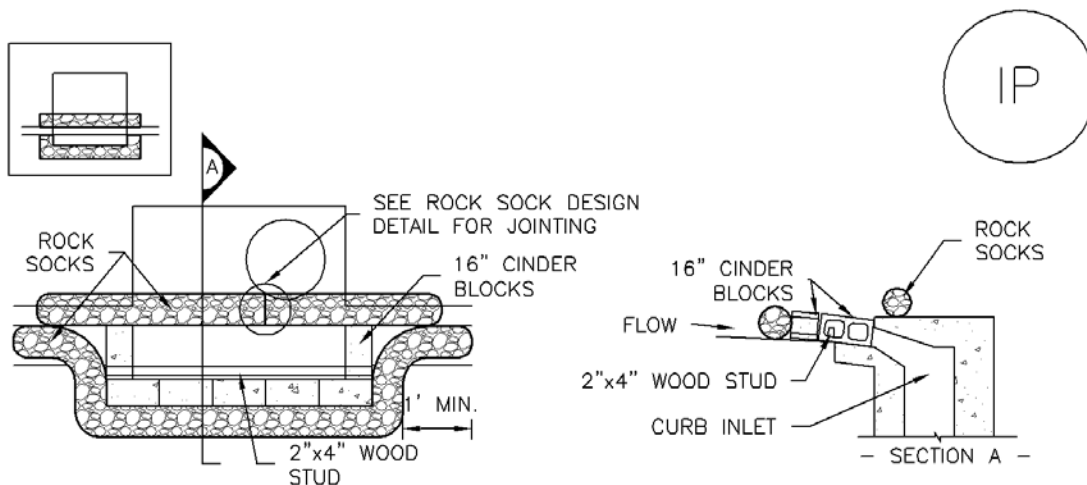

**IP-1. BLOCK AND ROCK SOCK SUMP OR ON GRADE INLET PROTECTION**

**BLOCK AND CURB SOCK INLET PROTECTION INSTALLATION NOTES**

1. SEE ROCK SOCK DESIGN DETAIL FOR INSTALLATION REQUIREMENTS.
2. CONCRETE "CINDER" BLOCKS SHALL BE LAID ON THEIR SIDES AROUND THE INLET IN A SINGLE ROW, ABUTTING ONE ANOTHER WITH THE OPEN END FACING AWAY FROM THE CURB.
3. GRAVEL BAGS SHALL BE PLACED AROUND CONCRETE BLOCKS, CLOSELY ABUTTING ONE ANOTHER AND JOINTED TOGETHER IN ACCORDANCE WITH ROCK SOCK DESIGN DETAIL.

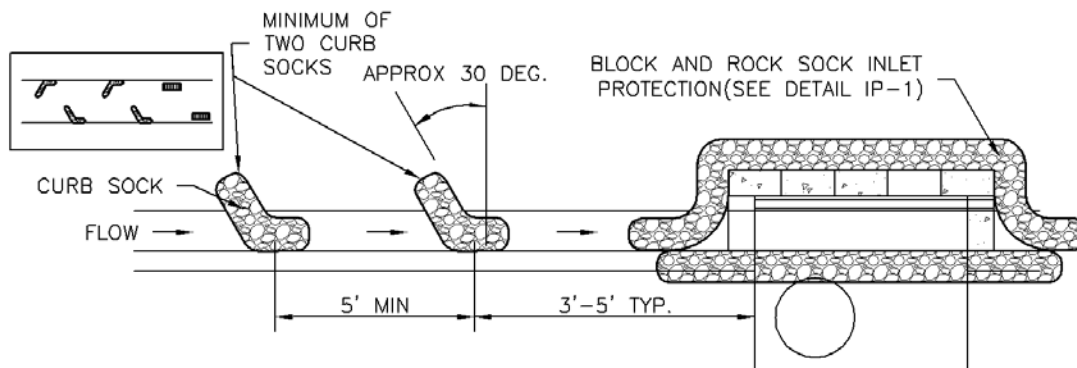

**IP-2. CURB ROCK SOCKS UPSTREAM OF INLET PROTECTION**

**CURB ROCK SOCK INLET PROTECTION INSTALLATION NOTES**

1. SEE ROCK SOCK DESIGN DETAIL INSTALLATION REQUIREMENTS.
2. PLACEMENT OF THE SOCK SHALL BE APPROXIMATELY 30 DEGREES FROM PERPENDICULAR IN THE OPPOSITE DIRECTION OF FLOW.
3. SOCKS ARE TO BE FLUSH WITH THE CURB AND SPACED A MINIMUM OF 5 FEET APART.
4. AT LEAST TWO CURB SOCKS IN SERIES ARE REQUIRED UPSTREAM OF ON-GRADE INLETS.

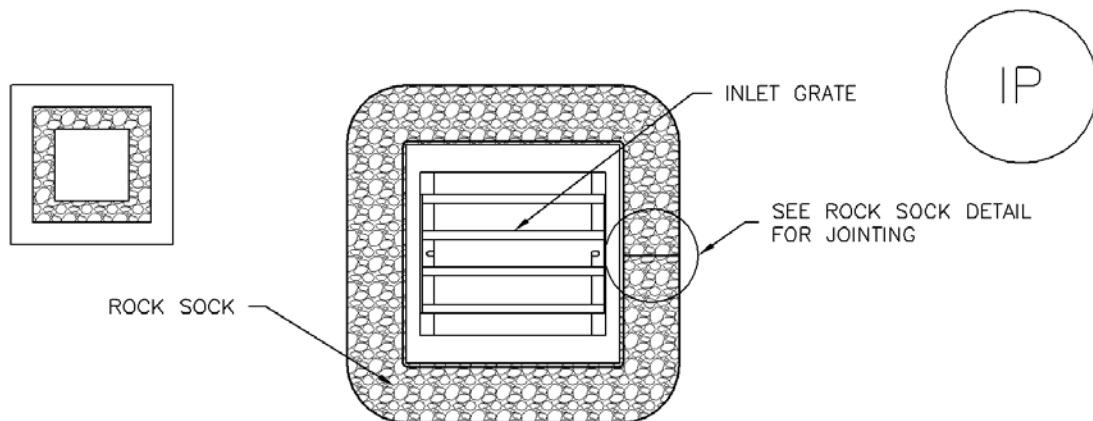

## IP-3. ROCK SOCK SUMP/AREA INLET PROTECTION

### ROCK SOCK SUMP/AREA INLET PROTECTION INSTALLATION NOTES

1. SEE ROCK SOCK DESIGN DETAIL FOR INSTALLATION REQUIREMENTS.
2. STRAW WATTLES/SEDIMENT CONTROL LOGS MAY BE USED IN PLACE OF ROCK SOCKS FOR INLETS IN PERVIOUS AREAS. INSTALL PER SEDIMENT CONTROL LOG DETAIL.

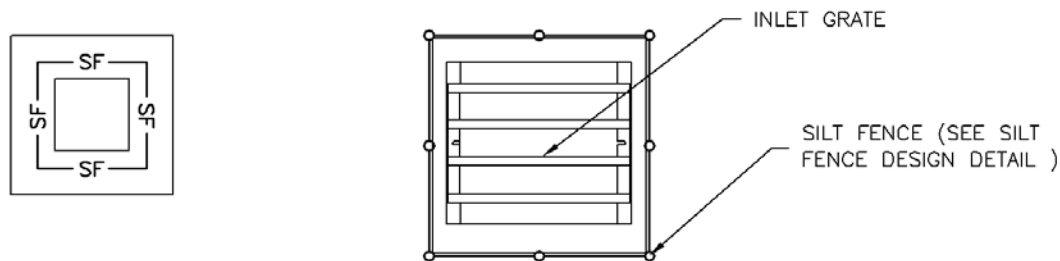

## IP-4. SILT FENCE FOR SUMP INLET PROTECTION

### SILT FENCE INLET PROTECTION INSTALLATION NOTES

1. SEE SILT FENCE DESIGN DETAIL FOR INSTALLATION REQUIREMENTS.
2. POSTS SHALL BE PLACED AT EACH CORNER OF THE INLET AND AROUND THE EDGES AT A MAXIMUM SPACING OF 3 FEET.
3. STRAW WATTLES/SEDIMENT CONTROL LOGS MAY BE USED IN PLACE OF SILT FENCE FOR INLETS IN PERVIOUS AREAS. INSTALL PER SEDIMENT CONTROL LOG DETAIL.

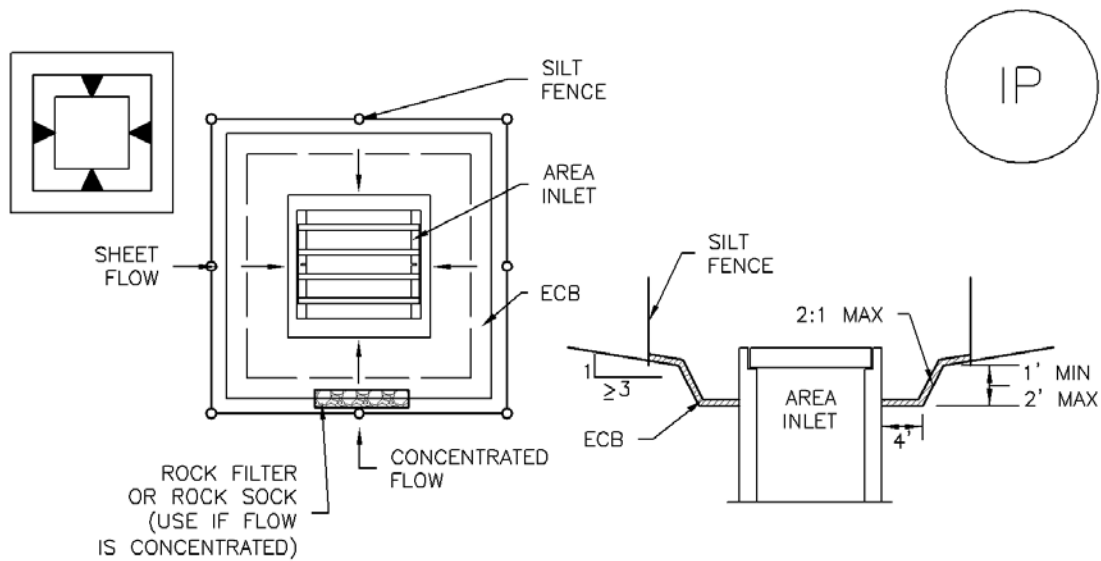

IP-5. OVEREXCAVATION INLET PROTECTION

OVEREXCAVATION INLET PROTECTION INSTALLATION NOTES

1. THIS FORM OF INLET PROTECTION IS PRIMARILY APPLICABLE FOR SITES THAT HAVE NOT YET REACHED FINAL GRADE AND SHOULD BE USED ONLY FOR INLETS WITH A RELATIVELY SMALL CONTRIBUTING DRAINAGE AREA.
2. WHEN USING FOR CONCENTRATED FLOWS, SHAPE BASIN IN 2:1 RATIO WITH LENGTH ORIENTED TOWARDS DIRECTION OF FLOW.
3. SEDIMENT MUST BE PERIODICALLY REMOVED FROM THE OVEREXCAVATED AREA.

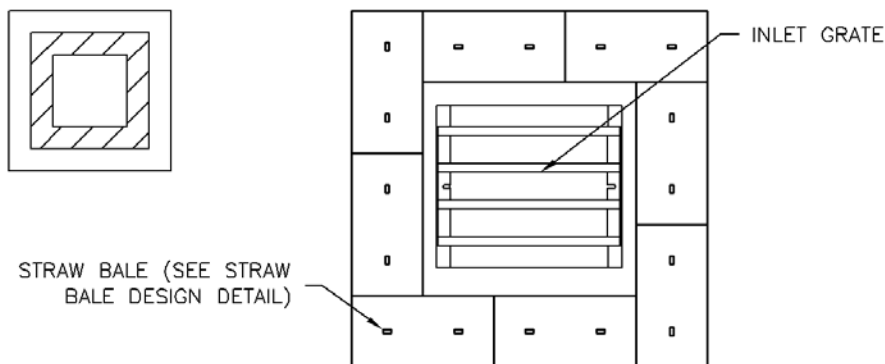

IP-6. STRAW BALE FOR SUMP INLET PROTECTION

STRAW BALE BARRIER INLET PROTECTION INSTALLATION NOTES

1. SEE STRAW BALE DESIGN DETAIL FOR INSTALLATION REQUIREMENTS.
2. BALES SHALL BE PLACED IN A SINGLE ROW AROUND THE INLET WITH ENDS OF BALES TIGHTLY ABUTTING ONE ANOTHER.



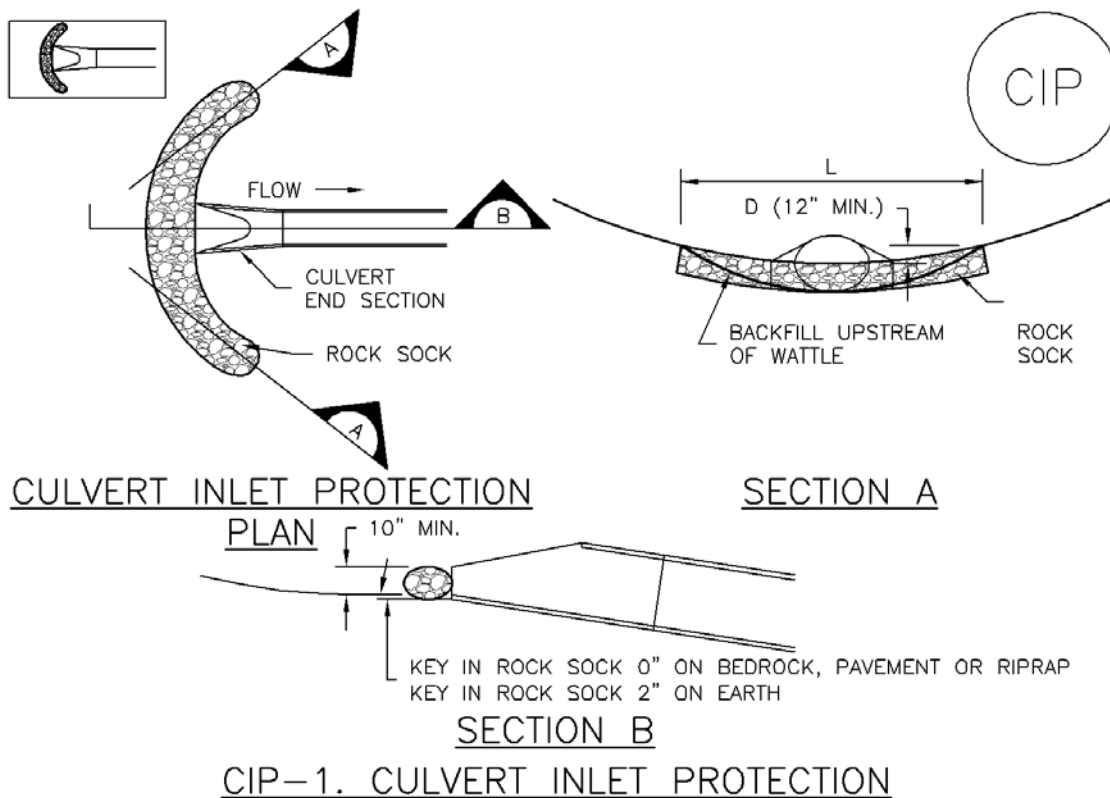

**CULVERT INLET PROTECTION INSTALLATION NOTES**

1. SEE PLAN VIEW FOR  
-LOCATION OF CULVERT INLET PROTECTION.
2. SEE ROCK SOCK DESIGN DETAIL FOR ROCK GRADATION REQUIREMENTS AND JOINTING DETAIL.

**CULVERT INLET PROTECTION MAINTENANCE NOTES**

1. INSPECT BMPs EACH WORKDAY, AND MAINTAIN THEM IN EFFECTIVE OPERATING CONDITION. MAINTENANCE OF BMPs SHOULD BE PROACTIVE, NOT REACTIVE. INSPECT BMPs AS SOON AS POSSIBLE (AND ALWAYS WITHIN 24 HOURS) FOLLOWING A STORM THAT CAUSES SURFACE EROSION, AND PERFORM NECESSARY MAINTENANCE.
2. FREQUENT OBSERVATIONS AND MAINTENANCE ARE NECESSARY TO MAINTAIN BMPs IN EFFECTIVE OPERATING CONDITION. INSPECTIONS AND CORRECTIVE MEASURES SHOULD BE DOCUMENTED THOROUGHLY.
3. WHERE BMPs HAVE FAILED, REPAIR OR REPLACEMENT SHOULD BE INITIATED UPON DISCOVERY OF THE FAILURE.
4. SEDIMENT ACCUMULATED UPSTREAM OF THE CULVERT SHALL BE REMOVED WHEN THE SEDIMENT DEPTH IS 1/2 THE HEIGHT OF THE ROCK SOCK.
5. CULVERT INLET PROTECTION SHALL REMAIN IN PLACE UNTIL THE UPSTREAM DISTURBED AREA IS PERMANENTLY STABILIZED AND APPROVED BY THE LOCAL JURISDICTION.

(DETAILS ADAPTED FROM AURORA, COLORADO, NOT AVAILABLE IN AUTOCAD)

**NOTE:** MANY JURISDICTIONS HAVE BMP DETAILS THAT VARY FROM UDFCD STANDARD DETAILS. CONSULT WITH LOCAL JURISDICTIONS AS TO WHICH DETAIL SHOULD BE USED WHEN DIFFERENCES ARE NOTED.

GENERAL INLET PROTECTION INSTALLATION NOTES

1. SEE PLAN VIEW FOR:
  - LOCATION OF INLET PROTECTION.
  - TYPE OF INLET PROTECTION (IP.1, IP.2, IP.3, IP.4, IP.5, IP.6)
2. INLET PROTECTION SHALL BE INSTALLED PROMPTLY AFTER INLET CONSTRUCTION OR PAVING IS COMPLETE (TYPICALLY WITHIN 48 HOURS). IF A RAINFALL/RUNOFF EVENT IS FORECAST, INSTALL INLET PROTECTION PRIOR TO ONSET OF EVENT.
3. MANY JURISDICTIONS HAVE BMP DETAILS THAT VARY FROM UDFCD STANDARD DETAILS. CONSULT WITH LOCAL JURISDICTIONS AS TO WHICH DETAIL SHOULD BE USED WHEN DIFFERENCES ARE NOTED.

INLET PROTECTION MAINTENANCE NOTES

1. INSPECT BMPs EACH WORKDAY, AND MAINTAIN THEM IN EFFECTIVE OPERATING CONDITION. MAINTENANCE OF BMPs SHOULD BE PROACTIVE, NOT REACTIVE. INSPECT BMPs AS SOON AS POSSIBLE (AND ALWAYS WITHIN 24 HOURS) FOLLOWING A STORM THAT CAUSES SURFACE EROSION, AND PERFORM NECESSARY MAINTENANCE.
2. FREQUENT OBSERVATIONS AND MAINTENANCE ARE NECESSARY TO MAINTAIN BMPs IN EFFECTIVE OPERATING CONDITION. INSPECTIONS AND CORRECTIVE MEASURES SHOULD BE DOCUMENTED THOROUGHLY.
3. WHERE BMPs HAVE FAILED, REPAIR OR REPLACEMENT SHOULD BE INITIATED UPON DISCOVERY OF THE FAILURE.
4. SEDIMENT ACCUMULATED UPSTREAM OF INLET PROTECTION SHALL BE REMOVED AS NECESSARY TO MAINTAIN BMP EFFECTIVENESS, TYPICALLY WHEN STORAGE VOLUME REACHES 50% OF CAPACITY, A DEPTH OF 6" WHEN SILT FENCE IS USED, OR ¼ OF THE HEIGHT FOR STRAW BALES.
5. INLET PROTECTION IS TO REMAIN IN PLACE UNTIL THE UPSTREAM DISTURBED AREA IS PERMANENTLY STABILIZED, UNLESS THE LOCAL JURISDICTION APPROVES EARLIER REMOVAL OF INLET PROTECTION IN STREETS.
6. WHEN INLET PROTECTION AT AREA INLETS IS REMOVED, THE DISTURBED AREA SHALL BE COVERED WITH TOP SOIL, SEEDED AND MULCHED, OR OTHERWISE STABILIZED IN A MANNER APPROVED BY THE LOCAL JURISDICTION.

(DETAIL ADAPTED FROM TOWN OF PARKER, COLORADO AND CITY OF AURORA, COLORADO, NOT AVAILABLE IN AUTOCAD)

NOTE: MANY JURISDICTIONS HAVE BMP DETAILS THAT VARY FROM UDFCD STANDARD DETAILS. CONSULT WITH LOCAL JURISDICTIONS AS TO WHICH DETAIL SHOULD BE USED WHEN DIFFERENCES ARE NOTED.

NOTE: THE DETAILS INCLUDED WITH THIS FACT SHEET SHOW COMMONLY USED, CONVENTIONAL METHODS OF INLET PROTECTION IN THE DENVER METROPOLITAN AREA. THERE ARE MANY PROPRIETARY INLET PROTECTION METHODS ON THE MARKET. UDFCD NEITHER ENDORSES NOR DISCOURAGES USE OF PROPRIETARY INLET PROTECTION; HOWEVER, IN THE EVENT PROPRIETARY METHODS ARE USED, THE APPROPRIATE DETAIL FROM THE MANUFACTURER MUST BE INCLUDED IN THE SWMP AND THE BMP MUST BE INSTALLED AND MAINTAINED AS SHOWN IN THE MANUFACTURER'S DETAILS.

NOTE: SOME MUNICIPALITIES DISCOURAGE OR PROHIBIT THE USE OF STRAW BALES FOR INLET PROTECTION. CHECK WITH LOCAL JURISDICTION TO DETERMINE IF STRAW BALE INLET PROTECTION IS ACCEPTABLE.

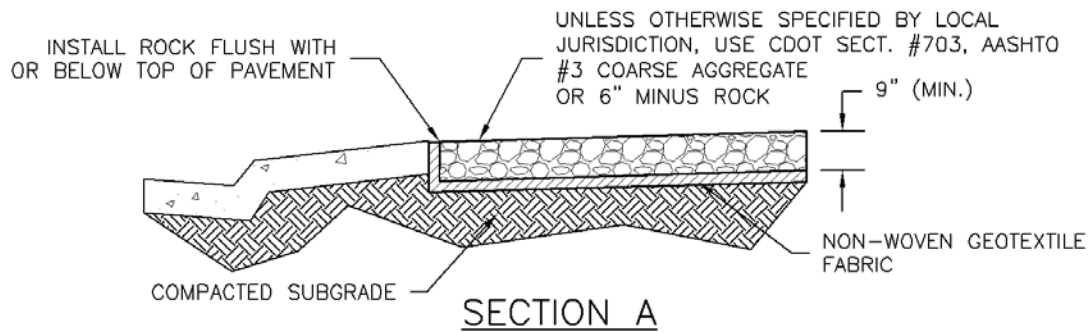
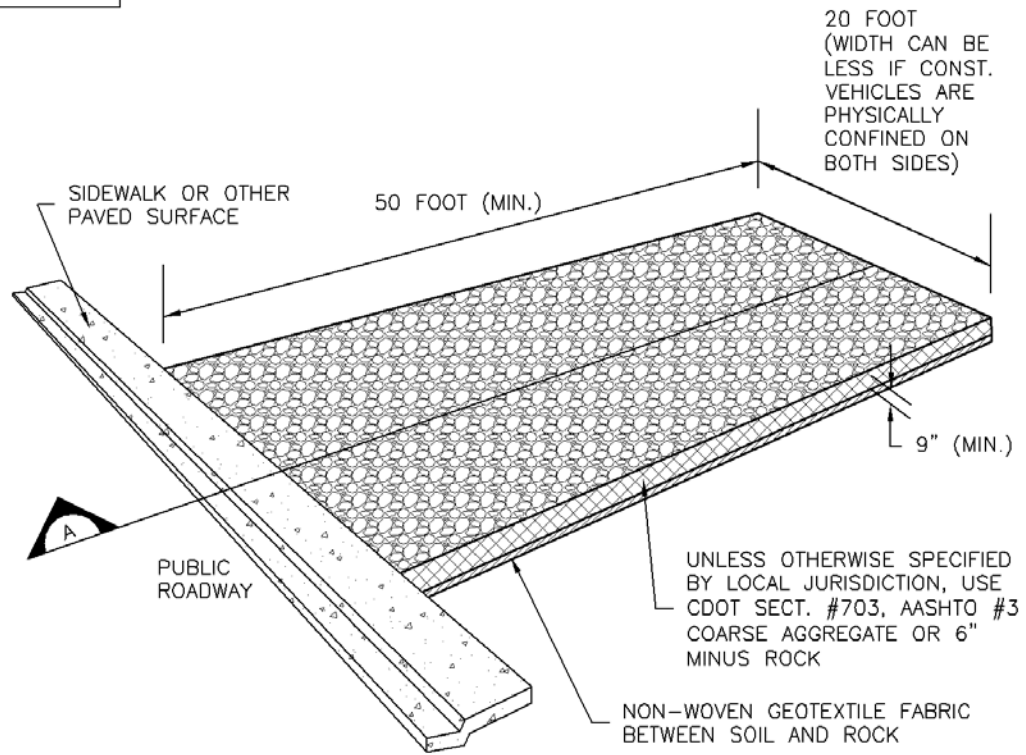
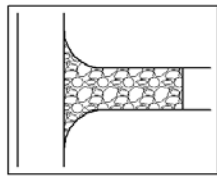

## VTC-1. AGGREGATE VEHICLE TRACKING CONTROL

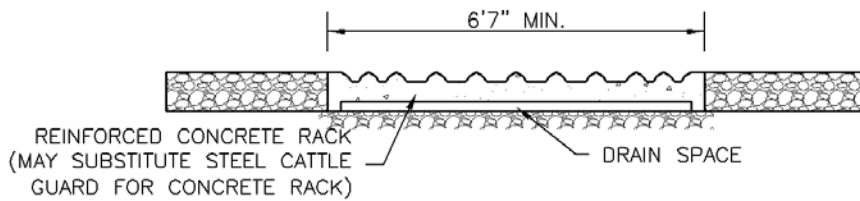
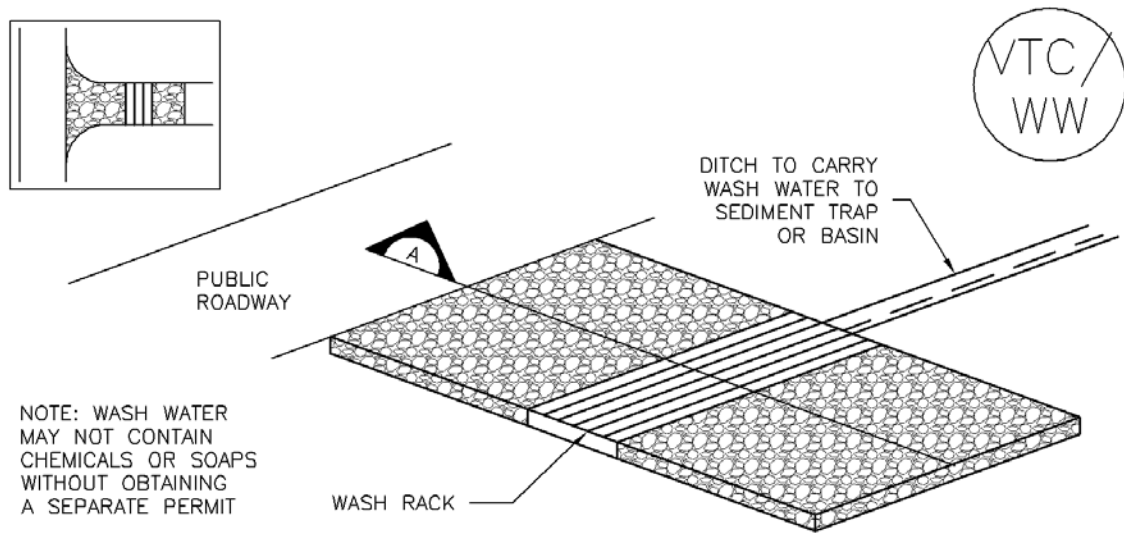

SECTION A

VTC-2. AGGREGATE VEHICLE TRACKING CONTROL WITH WASH RACK

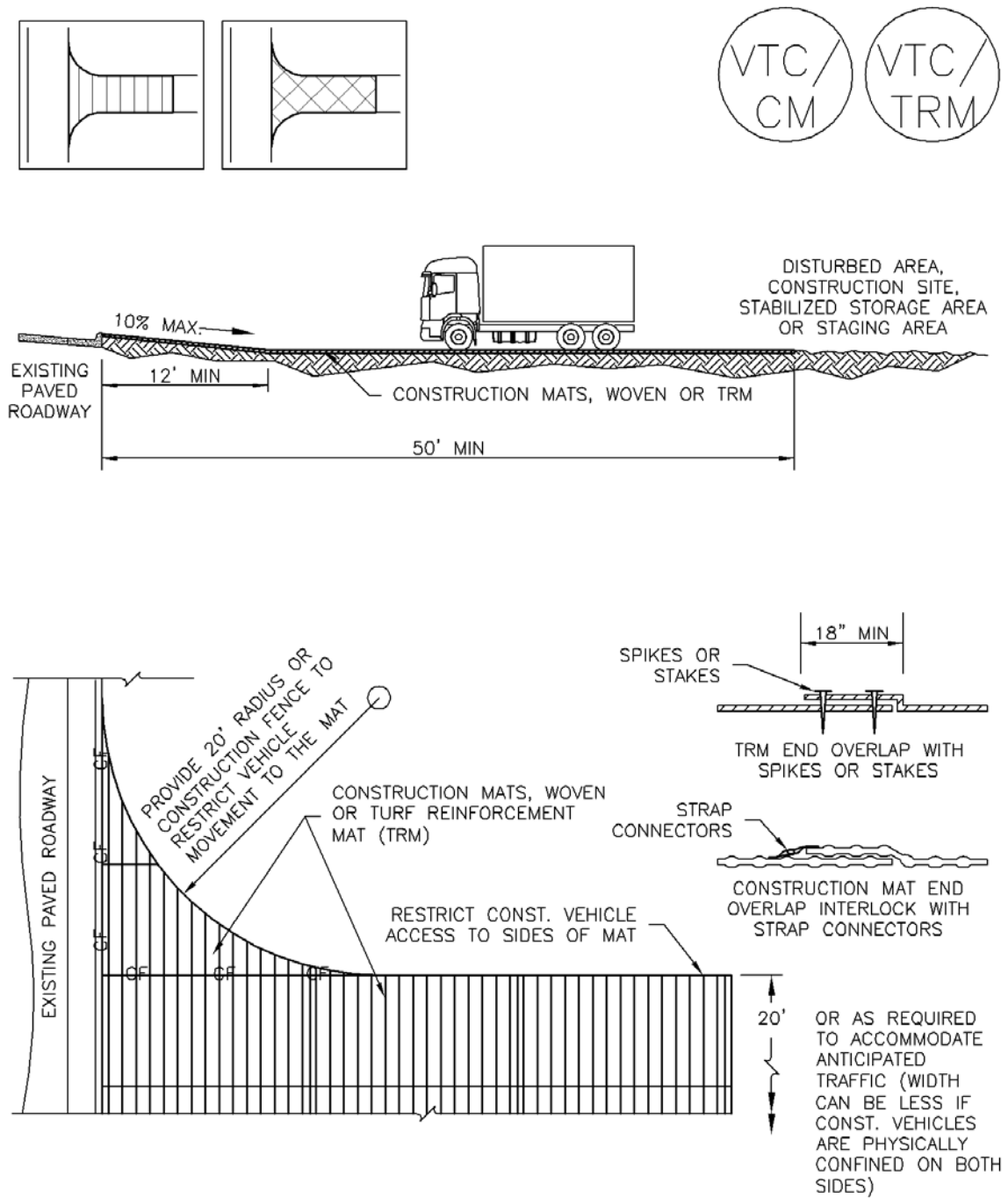

### VTC-3. VEHICLE TRACKING CONTROL W/ CONSTRUCTION MAT OR TURF REINFORCEMENT MAT (TRM)

STABILIZED CONSTRUCTION ENTRANCE/EXIT INSTALLATION NOTES

1. SEE PLAN VIEW FOR
  - LOCATION OF CONSTRUCTION ENTRANCE(S)/EXIT(S).
  - TYPE OF CONSTRUCTION ENTRANCE(S)/EXITS(S) (WITH/WITHOUT WHEEL WASH, CONSTRUCTION MAT OR TRM).
2. CONSTRUCTION MAT OR TRM STABILIZED CONSTRUCTION ENTRANCES ARE ONLY TO BE USED ON SHORT DURATION PROJECTS (TYPICALLY RANGING FROM A WEEK TO A MONTH) WHERE THERE WILL BE LIMITED VEHICULAR ACCESS.
3. A STABILIZED CONSTRUCTION ENTRANCE/EXIT SHALL BE LOCATED AT ALL ACCESS POINTS WHERE VEHICLES ACCESS THE CONSTRUCTION SITE FROM PAVED RIGHT-OF-WAYS.
4. STABILIZED CONSTRUCTION ENTRANCE/EXIT SHALL BE INSTALLED PRIOR TO ANY LAND DISTURBING ACTIVITIES.
5. A NON-WOVEN GEOTEXTILE FABRIC SHALL BE PLACED UNDER THE STABILIZED CONSTRUCTION ENTRANCE/EXIT PRIOR TO THE PLACEMENT OF ROCK.
6. UNLESS OTHERWISE SPECIFIED BY LOCAL JURISDICTION, ROCK SHALL CONSIST OF DOT SECT. #703, AASHTO #3 COARSE AGGREGATE OR 6" (MINUS) ROCK.

STABILIZED CONSTRUCTION ENTRANCE/EXIT MAINTENANCE NOTES

1. INSPECT BMPs EACH WORKDAY, AND MAINTAIN THEM IN EFFECTIVE OPERATING CONDITION. MAINTENANCE OF BMPs SHOULD BE PROACTIVE, NOT REACTIVE. INSPECT BMPs AS SOON AS POSSIBLE (AND ALWAYS WITHIN 24 HOURS) FOLLOWING A STORM THAT CAUSES SURFACE EROSION, AND PERFORM NECESSARY MAINTENANCE.
2. FREQUENT OBSERVATIONS AND MAINTENANCE ARE NECESSARY TO MAINTAIN BMPs IN EFFECTIVE OPERATING CONDITION. INSPECTIONS AND CORRECTIVE MEASURES SHOULD BE DOCUMENTED THOROUGHLY.
3. WHERE BMPs HAVE FAILED, REPAIR OR REPLACEMENT SHOULD BE INITIATED UPON DISCOVERY OF THE FAILURE.
4. ROCK SHALL BE REAPPLIED OR REGRADED AS NECESSARY TO THE STABILIZED ENTRANCE/EXIT TO MAINTAIN A CONSISTENT DEPTH.
5. SEDIMENT TRACKED ONTO PAVED ROADS IS TO BE REMOVED THROUGHOUT THE DAY AND AT THE END OF THE DAY BY SHOVELING OR SWEEPING. SEDIMENT MAY NOT BE WASHED DOWN STORM SEWER DRAINS.

NOTE: MANY JURISDICTIONS HAVE BMP DETAILS THAT VARY FROM UDFCD STANDARD DETAILS. CONSULT WITH LOCAL JURISDICTIONS AS TO WHICH DETAIL SHOULD BE USED WHEN DIFFERENCES ARE NOTED.

(DETAILS ADAPTED FROM CITY OF BROOMFIELD, COLORADO, NOT AVAILABLE IN AUTOCAD)

**SITE MAP/ EROSION AND STORMWATER  
QUALITY CONTROL PLAN**

GENERAL CONSTRUCTION NOTES:

- 1. ALL CONSTRUCTION WITHIN EL PASO COUNTY PUBLIC RIGHT-WAYS SHALL BE IN ACCORDANCE WITH MOST CURRENT STANDARDS AND SPECIFICATIONS OF EL PASO COUNTY.
2. IT SHALL BE THE RESPONSIBILITY OF THE CONTRACTOR TO VERIFY THE EXISTENCE AND LOCATION OF ALL UNDERGROUND UTILITIES ALONG THE ROUTE OF THE WORK.
3. BEFORE COMMENCING ANY EXCAVATION, CALL 811 FOR EXISTING UTILITY LOCATIONS.
4. THE CONTRACTOR WILL TAKE THE NECESSARY PRECAUTIONS TO PROTECT EXISTING UTILITIES FROM DAMAGE DUE TO THIS OPERATION.
5. ADDITIONAL EROSION CONTROL STRUCTURES MAY BE REQUIRED AT THE TIME OF CONSTRUCTION.
6. ALL BACKFILL, SUB-BASE AND/OR BASE COURSE (CLASS 6) MATERIAL SHALL BE COMPACTED TO THE SOILS ENGINEER'S RECOMMENDATIONS, AND APPROVED BY EL PASO COUNTY DEVELOPMENT SERVICES ENGINEERING DIVISION.
7. ALL STATIONING IS CENTERLINE UNLESS OTHERWISE INDICATED. ALL ELEVATIONS ARE FLOWLINE UNLESS OTHERWISE INDICATED.
8. ALL DISTURBED PAVEMENT EDGES SHALL BE CUT TO NEAT LINES. REPAIR SHALL CONFORM TO THE EPC ECM APPENDIX K - 1.2C.
9. ALL INTERSECTION ACCESSES TO BE CONSTRUCTED WITH A 25 FOOT SIGHT VISIBILITY TRIANGLE.
10. ALL CULVERT AND STORM DRAIN PIPES SHALL BE SMOOTH INTERIOR CORRUGATED POLYETHYLENE PIPE (HDPE), REINFORCED CONCRETE PIPE (RCP).
11. ASPHALT THICKNESS AND BASE COURSE THICKNESS (COMPACTED) FOR ROADS SHALL BE PER DESIGN REPORT BY OWNER'S GEOTECHNICAL ENGINEER.
12. TYPE M RIP-RAP WITH 4" OF TYPE II GRANULAR BEDDING AND MIRAFI 180N OR EQUAL MAY BE SUBSTITUTED WHERE TYPE L RIP-RAP WITH MIRAFI FW 700 OR EQUAL IS SPECIFIED.
13. ALL MATERIALS AND INSTALLATION PROCEDURES SHALL BE IN COMPLIANCE WITH ANY AND ALL APPLICABLE EL PASO COUNTY STANDARDS.
14. ALL POTABLE WATER MAINS SHALL BE AWMA C900-CLASS 200 (DR14) PVC WITH PUSH-ON SINGLE GASKET TYPE JOINTS AND SHALL MEET THE REQUIREMENTS OF ANSI/NSF 61.
15. ALL WATER MAIN FITTINGS SHALL BE MADE FROM GRAY-IRON OR DUCTILE IRON AND FURNISHED WITH MECHANICAL JOINT ENDS.
16. ALL WATER LINE BENDS, TEES, BLOW-OFFS AND PLUGS AT DEAD-END MAINS SHALL BE PROTECTED FROM THRUST BY USING CONCRETE THRUST BLOCKS AND/OR RODDING AND RESTRAINED PIPE.
17. MAXIMUM DEFLECTION OF 8" & 12" PVC WATER MAIN JOINTS IS 1 DEGREE OR LESS PER THE MANUFACTURERS RECOMMENDATIONS.
18. CONTRACTOR IS RESPONSIBLE FOR PROVIDING DETAILED AS-BUILTS OF ALL WATER MAIN, STORM SEW AND SAN. SEW. MAIN INSTALLATIONS, INCLUDING ACCURATE DISTANCES OF MAIN LINES, VALVES, FITTINGS, MANHOLES AND LOCATIONS OF WATER AND SEWER SERVICES.
19. SANITARY SEWER PIPE AND FITTINGS: PVC 4"-8" ASTM D3034, TYPE PSM, SDR 35: PUSH-ON JOINTS AND MOLDED RUBBER GASKETS MAXIMUM HORIZONTAL DEFLECTION, AFTER INSTALLATION AND BACK FILLING SHALL NOT EXCEED 3% OF THE PIPE DIAMETER.

EL PASO COUNTY GRADING AND EROSION CONTROL NOTES:

- 1. STORMWATER DISCHARGES FROM CONSTRUCTION SITES SHALL NOT CAUSE OR THREATEN TO CAUSE POLLUTION, CONTAMINATION, OR DEGRADATION OF STATE WATERS. ALL WORK AND EARTH DISTURBANCE SHALL BE DONE IN A MANNER THAT MINIMIZES POLLUTION OF ANY ON-SITE OR OFF-SITE WATERS, INCLUDING WETLANDS.
2. NOTWITHSTANDING ANYTHING DEPICTED IN THESE PLANS IN WORDS OR GRAPHIC REPRESENTATION, ALL DESIGN AND CONSTRUCTION RELATED TO ROADS, STORM DRAINAGE AND EROSION CONTROL SHALL CONFORM TO THE STANDARDS AND REQUIREMENTS OF THE MOST RECENT VERSION OF THE RELEVANT ADOPTED EL PASO COUNTY STANDARDS, INCLUDING THE LAND DEVELOPMENT CODE, THE ENGINEERING CRITERIA MANUAL, THE DRAINAGE CRITERIA MANUAL, AND THE DRAINAGE CRITERIA MANUAL VOLUME 2.
3. A SEPARATE STORMWATER MANAGEMENT PLAN (SWMP) FOR THIS PROJECT SHALL BE COMPLETED AND AN EROSION AND STORMWATER QUALITY CONTROL PERMIT (ESQCP) ISSUED PRIOR TO COMMENCING CONSTRUCTION.
4. ONCE THE ESQCP IS APPROVED AND A NOTICE TO PROCEED HAS BEEN ISSUED, THE CONTRACTOR MAY INSTALL THE INITIAL STAGE EROSION AND SEDIMENT CONTROL MEASURES AS INDICATED ON THIS PLAN.
5. CONTROL MEASURES MUST BE INSTALLED PRIOR TO COMMENCEMENT OF ACTIVITIES THAT COULD CONTRIBUTE POLLUTANTS TO STORMWATER.
6. ALL TEMPORARY SEDIMENT AND EROSION CONTROL MEASURES SHALL BE MAINTAINED AND REMAIN IN EFFECTIVE OPERATING CONDITION UNTIL PERMANENT SOIL EROSION CONTROL MEASURES ARE IMPLEMENTED AND FINAL STABILIZATION IS ESTABLISHED.
7. TEMPORARY STABILIZATION SHALL BE IMPLEMENTED ON DISTURBED AREAS AND STOCKPILES WHERE GROUND DISTURBING CONSTRUCTION ACTIVITY HAS PERMANENTLY CEASED OR TEMPORARILY CEASED FOR LONGER THAN 14 DAYS.
8. FINAL STABILIZATION MUST BE IMPLEMENTED AT ALL APPLICABLE CONSTRUCTION SITES. FINAL STABILIZATION IS ACHIEVED WHEN ALL GROUND DISTURBING ACTIVITIES ARE COMPLETE AND ALL DISTURBED AREAS EITHER HAVE A UNIFORM VEGETATIVE COVER WITH INDIVIDUAL PLANT DENSITY OF 70 PERCENT OF PRE-DISTURBANCE LEVELS ESTABLISHED OR EQUIVALENT PERMANENT ALTERNATIVE STABILIZATION METHOD IS IMPLEMENTED.
9. ALL PERMANENT STORMWATER MANAGEMENT FACILITIES SHALL BE INSTALLED AS DESIGNED IN THE APPROVED PLANS.
10. EARTH DISTURBANCES SHALL BE CONDUCTED IN SUCH A MANNER SO AS TO EFFECTIVELY MINIMIZE ACCELERATED SOIL EROSION AND RESULTING SEDIMENTATION.
11. COMPACTION OF SOIL MUST BE PREVENTED IN AREAS DESIGNATED FOR INFILTRATION CONTROL MEASURES OR WHERE FINAL STABILIZATION WILL BE ACHIEVED BY VEGETATIVE COVER.
12. ANY TEMPORARY OR PERMANENT FACILITY DESIGNED AND CONSTRUCTED FOR THE CONVEYANCE OF STORMWATER AROUND, THROUGH, OR FROM THE EARTH DISTURBANCE AREA SHALL BE A STABILIZED CONVEYANCE DESIGNED TO MINIMIZE EROSION AND THE DISCHARGE OF SEDIMENT OFF SITE.
13. CONCRETE WASH WATER SHALL BE CONTAINED AND DISPOSED OF IN ACCORDANCE WITH THE SWMP. NO WASH WATER SHALL BE DISCHARGED TO OR ALLOWED TO ENTER STATE WATERS.
14. DURING DEWATERING OPERATIONS OF UNCONTAMINATED GROUND WATER MAY BE DISCHARGED ON SITE, BUT SHALL NOT LEAVE THE SITE IN THE FORM OF SURFACE RUNOFF UNLESS AN APPROVED STATE DEWATERING PERMIT IS IN PLACE.
15. EROSION CONTROL BLANKETING OR OTHER PROTECTIVE COVERING SHALL BE USED ON SLOPES STEEPER THAN 3:1.
16. CONTRACTOR SHALL BE RESPONSIBLE FOR THE REMOVAL OF ALL WASTES FROM THE CONSTRUCTION SITE FOR DISPOSAL IN ACCORDANCE WITH LOCAL AND STATE REGULATORY REQUIREMENTS.
17. WASTE MATERIALS SHALL NOT BE TEMPORARILY PLACED OR STORED IN THE STREET, ALLEY, OR OTHER PUBLIC WAY, UNLESS IN ACCORDANCE WITH AN APPROVED TRAFFIC CONTROL PLAN.
18. TRACKING OF SOILS AND CONSTRUCTION DEBRIS OFF-SITE SHALL BE MINIMIZED.
19. THE OWNER/DEVELOPER SHALL BE RESPONSIBLE FOR THE REMOVAL OF ALL CONSTRUCTION DEBRIS, DIRT, TRASH, ROCK, SEDIMENT, SOIL, AND SAND THAT MAY ACCUMULATE IN ROADS, STORM DRAINS AND OTHER DRAINAGE CONVEYANCE SYSTEMS AND STORMWATER APPURTENANCES AS A RESULT OF SITE DEVELOPMENT.
20. THE QUANTITY OF MATERIALS STORED ON THE PROJECT SITE SHALL BE LIMITED, AS MUCH AS PRACTICAL, TO THAT QUANTITY REQUIRED TO PERFORM THE WORK IN AN ORDERLY SEQUENCE.
21. NO CHEMICAL(S) HAVING THE POTENTIAL TO BE RELEASED IN STORMWATER ARE TO BE STORED OR USED ON SITE UNLESS PERMISSION FOR THE USE OF SUCH CHEMICAL(S) IS GRANTED IN WRITING BY THE EGM ADMINISTRATOR.
22. BULK STORAGE OF ALLOWED PETROLEUM PRODUCTS OR OTHER ALLOWED LIQUID CHEMICALS IN EXCESS OF 55 GALLONS SHALL REQUIRE ADEQUATE SECONDARY CONTAINMENT PROTECTION TO CONTAIN ALL SPILLS ON-SITE AND TO PREVENT ANY SPILLED MATERIALS FROM ENTERING STATE WATERS, ANY SURFACE OR SUBSURFACE STORM DRAINAGE SYSTEM OR OTHER FACILITIES.
23. NO PERSON SHALL CAUSE THE IMPEDIMENT OF STORMWATER FLOW IN THE CURB AND GUTTER OR DITCH EXCEPT WITH APPROVED SEDIMENT CONTROL MEASURES.
24. OWNER/DEVELOPER AND THEIR AGENTS SHALL COMPLY WITH THE "COLORADO WATER QUALITY CONTROL ACT" (TITLE 25, ARTICLE 8, CRS), AND THE "CLEAN WATER ACT" (33 USC 1344), IN ADDITION TO THE REQUIREMENTS OF THE LAND DEVELOPMENT CODE, DCM VOLUME II AND THE EGM APPENDIX I.
25. ALL CONSTRUCTION TRAFFIC MUST ENTER/EXIT THE SITE ONLY AT APPROVED CONSTRUCTION ACCESS POINTS.
26. PRIOR TO CONSTRUCTION THE PERMITTEE SHALL VERIFY THE LOCATION OF EXISTING UTILITIES.
27. A WATER SOURCE SHALL BE AVAILABLE ON SITE DURING EARTHWORK OPERATIONS AND SHALL BE UTILIZED AS REQUIRED TO MINIMIZE DUST FROM EARTHWORK EQUIPMENT AND WIND.
28. THE SOILS REPORT FOR THIS SITE HAS BEEN PREPARED BY ENTECH ENGINEERING, INC., TITLED "PRELIMINARY SUBSURFACE SOIL INVESTIGATION MIDTOWN AT HANNAH RIDGE TRACTS AA & BB", DATED DECEMBER 20, 2018, SF-19-006, AND SHALL BE CONSIDERED A PART OF THESE PLANS.
29. AT LEAST TEN (10) DAYS PRIOR TO THE ANTICIPATED START OF CONSTRUCTION, FOR PROJECTS THAT WILL DISTURB ONE (1) ACRE OR MORE, THE OWNER OR OPERATOR OF CONSTRUCTION ACTIVITY SHALL SUBMIT A PERMIT APPLICATION FOR STORMWATER DISCHARGE TO THE COLORADO DEPARTMENT OF PUBLIC HEALTH AND ENVIRONMENT, WATER QUALITY DIVISION. THE APPLICATION CONTAINS CERTIFICATION OF COMPLETION OF A STORMWATER MANAGEMENT PLAN (SWMP), OF WHICH THIS GRADING AND EROSION CONTROL PLAN MAY BE A PART. FOR INFORMATION OR APPLICATION MATERIALS CONTACT:

MIDTOWN COLLECTION AT HANNAH RIDGE FILING NO. 3

COUNTY OF EL PASO, STATE OF COLORADO

OVERLOT GRADING & EROSION CONTROL PLAN

DECEMBER 2021

SECTION 32, TOWNSHIP 13 SOUTH, RANGE 65 WEST

AGENCIES:

- DEVELOPER: ELITE PROPERTIES OF AMERICA, INC. 2138 FLYING HORSE CLUB DRIVE COLORADO SPRINGS, CO 80921 MR. JIM BOULTON (719) 592-9333
CIVIL ENGINEER: (SWMP PREPARER) CLASSIC CONSULTING ENGINEERS & SURVEYORS 619 N. CASCADE AVENUE, SUITE 200 COLORADO SPRINGS, CO 80903 MR. KYLE R. CAMPBELL, P.E. (719) 785-0790
COUNTY ENGINEERING: PLANNING AND COMMUNITY DEVELOPMENT 2880 INTERNATIONAL CIRCLE COLORADO SPRINGS, COLORADO 80910 MR. JEFF RICE, P.E. (719) 520-7877
WATER & SANITATION DISTRICT: CHEROKEE METRO DISTRICT 6250 PALMER PARK BLVD COLORADO SPRINGS, CO MR. JEFF MUNGER, P.E. (719) 597-5080
FIRE DISTRICT: FALCON FIRE PROTECTION DISTRICT 7030 N. MERIDIAN RD. FALCON, COLORADO 80831 CHIEF HARWIG (719) 495-4050
GAS COMPANY: CITY OF COLORADO SPRINGS 101 SOUTH CONEJOS STREET COLORADO SPRINGS, COLORADO 80903 MR. TIM BENEDICT, (719) 668-3574
ELECTRIC COMPANY: MOUNTAIN VIEW ELECTRIC P.O. BOX 1600 LIMON, COLORADO 80828 MR. LES ULFERS, (719) 495-2283
TELEPHONE COMPANY: CENTURY LINK COMMUNICATIONS 308 E. PIKES PEAK AVENUE COLORADO SPRINGS, COLORADO 80903 MS. MELISSA SPENCER (719) 636-4748 MELISSA.SPENCER@CENTURYLINK.COM
EARTHWORKS CONTRACTOR: RICE & RICE, INC. 8150 RICE LANE FOUNTAIN, COLORADO 80817 MR. TROY TRIMBLE, (719) 651-8089
STORMWATER MANAGER: CLASSIC HOMES 2138 FLYING HORSE CLUB DRIVE COLORADO SPRINGS, CO 80921 MR. BILL RITCHE (719) 619-7046

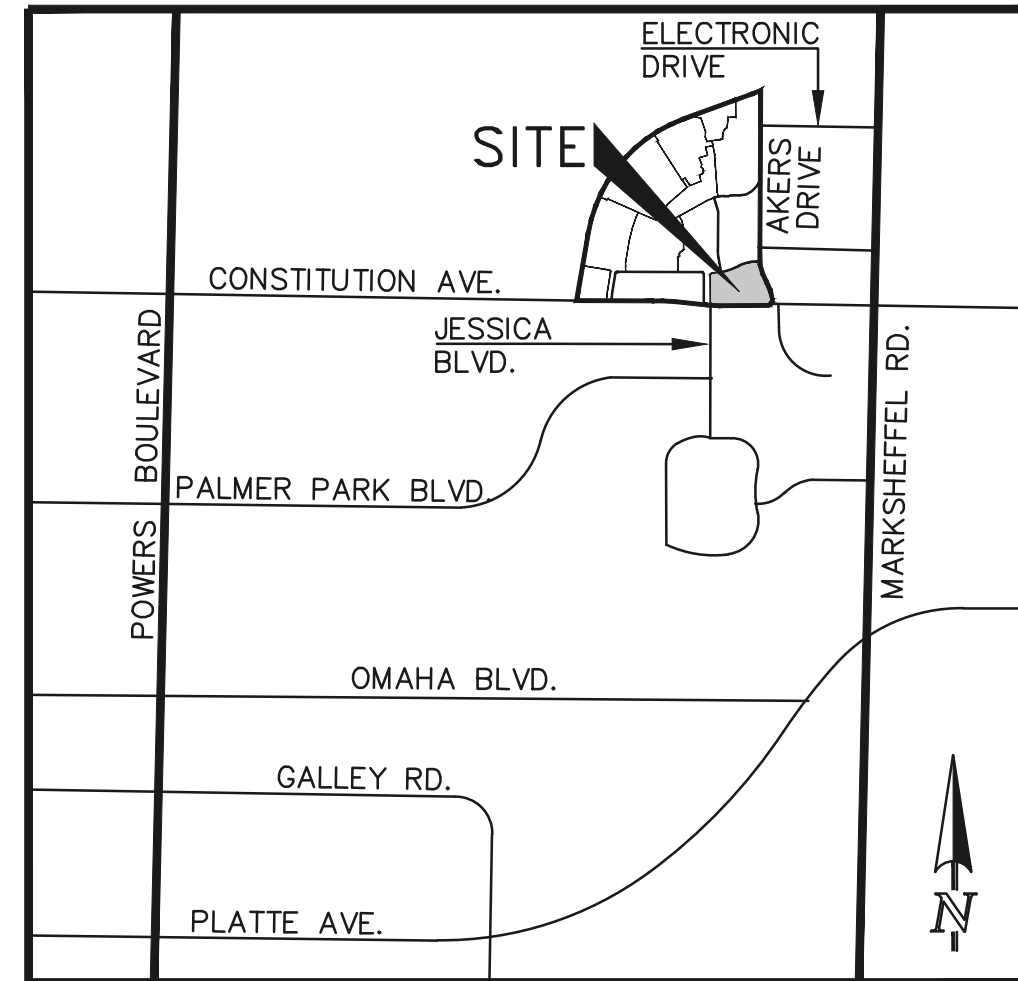

VICINITY MAP NOT TO SCALE

SHEET INDEX

Table with 2 columns: Description of sheet content and Sheet number. Includes Title Sheet, Overlot Grading Plan, and Grading/Erosion Control Details.

BENCHMARKS:

- A #5 REBAR LOCATED APPROXIMATELY 170 FEET NORTHEAST OF THE NORTHEASTLY CORNER OF TRACTS JJ AS PLATTED IN HANNAH RIDGE AT FEATHERGRASS FILING NO. 1, LABELED AS PANEL POINT #11 ELEVATION = 6523.79
A 1 INCH ORANGE PLASTIC CAP STAMPED "13225" LOCATED AT THE SOUTHWESTERLY CORNER OF TRACT AA AS PLATTED IN HANNAH RIDGE AT FEATHERGRASS FILING NO. 1 ELEVATION = 6485.00

BASIS OF BEARINGS:

A PORTION OF THE NORTHERLY RIGHT OF WAY OF CONSTITUTION AVENUE BEING MONUMENTED AT THE EAST END BY A 4M PLASTIC CAP STAMPED "PLS 13225" AND ON THE WEST END BY A PLASTIC CAP STAMPED "1V6 17665", IS ASSUMED TO BEAR N69°57'07"W, A DISTANCE OF 108.33 FEET.

EL PASO COUNTY STANDARD CONSTRUCTION NOTES:

- 1. ALL DRAINAGE AND ROADWAY CONSTRUCTION SHALL MEET THE STANDARDS AND SPECIFICATIONS OF THE CITY OF COLORADO SPRINGS/EL PASO COUNTY DRAINAGE CRITERIA MANUAL, VOLUMES 1 AND 2, AND THE EL PASO COUNTY ENGINEERING CRITERIA MANUAL.
2. CONTRACTOR SHALL BE RESPONSIBLE FOR THE NOTIFICATION AND FIELD NOTIFICATION OF ALL EXISTING UTILITIES, WHETHER SHOWN ON THE PLANS OR NOT, BEFORE BEGINNING CONSTRUCTION.
3. CONTRACTOR SHALL KEEP A COPY OF THESE APPROVED PLANS, THE GRADING AND EROSION CONTROL PLAN, THE STORMWATER MANAGEMENT PLAN (SWMP), THE SOILS AND GEOTECHNICAL REPORT, AND THE APPROPRIATE DESIGN AND CONSTRUCTION STANDARDS AND SPECIFICATIONS AT THE JOB SITE AT ALL TIMES, INCLUDING THE FOLLOWING:
4. NOTWITHSTANDING ANYTHING DEPICTED IN THESE PLANS IN WORDS OR GRAPHIC REPRESENTATION, ALL DESIGN AND CONSTRUCTION RELATED TO ROADS, STORM DRAINAGE AND EROSION CONTROL SHALL CONFORM TO THE STANDARDS AND REQUIREMENTS OF THE MOST RECENT VERSION OF THE RELEVANT ADOPTED EL PASO COUNTY STANDARDS, INCLUDING THE LAND DEVELOPMENT CODE, THE ENGINEERING CRITERIA MANUAL, THE DRAINAGE CRITERIA MANUAL, AND THE DRAINAGE CRITERIA MANUAL VOLUME 2.
5. IT IS THE DESIGN ENGINEER'S RESPONSIBILITY TO ACCURATELY SHOW EXISTING CONDITIONS, BOTH ON-SITE AND OFF-SITE, ON THE CONSTRUCTION PLANS.
6. CONTRACTOR SHALL SCHEDULE A PRE-CONSTRUCTION MEETING WITH EL PASO COUNTY DEVELOPMENT SERVICES DEPARTMENT (PCD) - INSPECTIONS, PRIOR TO STARTING CONSTRUCTION.
7. IT IS THE CONTRACTOR'S RESPONSIBILITY TO UNDERSTAND THE REQUIREMENTS OF ALL JURISDICTIONAL AGENCIES AND TO OBTAIN ALL REQUIRED PERMITS, INCLUDING BUT NOT LIMITED TO EL PASO COUNTY EROSION AND STORMWATER QUALITY CONTROL PERMIT (ESQCP), REGIONAL BUILDING FLOODPLAIN DEVELOPMENT PERMIT, U.S. ARMY CORPS OF ENGINEERS-ISSUED 401 AND/OR 404 PERMITS, AND COUNTY AND STATE FUGITIVE DUST PERMITS.
8. CONTRACTOR SHALL NOT DEVIATE FROM THE PLANS WITHOUT FIRST OBTAINING WRITTEN APPROVAL FROM THE DESIGN ENGINEER AND PCD.
9. ALL STORM DRAIN PIPE SHALL BE CLASS III RCP UNLESS OTHERWISE NOTED AND APPROVED BY PCD.
10. CONTRACTOR SHALL COORDINATE GEOTECHNICAL TESTING PER EGM STANDARDS. PAVEMENT DESIGN SHALL BE APPROVED BY EL PASO COUNTY PCD PRIOR TO PLACEMENT OF CURB AND GUTTER AND PAVEMENT.
11. ALL CONSTRUCTION TRAFFIC MUST ENTER/EXIT THE SITE AT APPROVED CONSTRUCTION ACCESS POINTS.
12. NIGHT VISIBILITY TRIANGLES AS IDENTIFIED IN THE PLANS SHALL BE PROVIDED AT ALL INTERSECTIONS. OBSTRUCTIONS GREATER THAN 18 INCHES ABOVE FLOWLINE ARE NOT ALLOWED WITHIN NIGHT TRIANGLES.
13. SIGNING AND STRIPING SHALL COMPLY WITH EL PASO COUNTY DOT AND MUTCD CRITERIA.
14. CONTRACTOR SHALL OBTAIN ANY PERMITS REQUIRED BY EL PASO COUNTY DOT, INCLUDING WORK WITHIN THE RIGHT-OF-WAY AND SPECIAL TRANSPORT PERMITS.
15. THE LIMITS OF CONSTRUCTION SHALL REMAIN WITHIN THE PROPERTY LINE UNLESS OTHERWISE NOTED. THE OWNER/DEVELOPER SHALL OBTAIN WRITTEN PERMISSION AND EASEMENTS, WHERE REQUIRED, FROM ADJOINING PROPERTY OWNER(S) PRIOR TO ANY OFF-SITE DISTURBANCE, GRADING, OR CONSTRUCTION.

TIMING SCHEDULE: ANTICIPATED STARTING AND COMPLETION TIME PERIOD OF SITE GRADING: MARCH 2022 EXPECTED DATE ON WHICH THE FINAL STABILIZATION WILL BE COMPLETED: MARCH 2023
AREAS: TOTAL AREA OF THE SITE TO BE CLEARED, EXCAVATED OR GRADED: 4.78 ACRES
RECEIVING WATERS: NAME OF RECEIVING WATERS: SAND CREEK DRAINAGE BASIN

APPROVALS:

ENGINEER'S STATEMENT:

GRADING AND EROSION CONTROL PLANS WITHIN CD'S ENGINEER'S STATEMENT: THESE DETAILED PLANS AND SPECIFICATIONS WERE PREPARED UNDER MY DIRECTION AND SUPERVISION. SAID PLANS AND SPECIFICATIONS HAVE BEEN PREPARED ACCORDING TO THE CRITERIA ESTABLISHED BY THE COUNTY FOR DETAILED ROADWAY, DRAINAGE, GRADING AND EROSION CONTROL PLANS AND SPECIFICATIONS, AND SAID PLANS AND SPECIFICATIONS ARE IN CONFORMITY WITH APPLICABLE MASTER DRAINAGE PLANS AND MASTER TRANSPORTATION PLANS. SAID PLANS AND SPECIFICATIONS MEET THE PURPOSES FOR WHICH THE PARTICULAR ROADWAY AND DRAINAGE FACILITIES ARE DESIGNED AND ARE CORRECT TO THE BEST OF MY KNOWLEDGE AND BELIEF.

KYLE R. CAMPBELL, CIVIL ENGINEER AND SWMP PREPARER FOR AND ON THE BEHALF OF CLASSIC CONSULTING ENGINEERS & SURVEYORS
DATE: 12/13/2021
Signature of Kyle R. Campbell

OWNER/DEVELOPER STATEMENT:

I, THE OWNER / DEVELOPER HAVE READ AND WILL COMPLY WITH THE REQUIREMENTS OF THE GRADING AND EROSION CONTROL PLAN AND ALL OF THE REQUIREMENTS SPECIFIED IN THESE DETAILED PLANS AND SPECIFICATIONS.
DATE: 12-13-21
Signature of Jim Boulton, Vice President, Elite Properties of America, Inc.

EL PASO COUNTY:

COUNTY PLAN REVIEW IS PROVIDED ONLY FOR GENERAL CONFORMANCE WITH COUNTY DESIGN CRITERIA. THE COUNTY IS NOT RESPONSIBLE FOR THE ACCURACY AND ADEQUACY OF THE DESIGN, DIMENSIONS, AND/OR ELEVATIONS WHICH SHALL BE CONFIRMED AT THE JOB SITE. THE COUNTY THROUGH THE APPROVAL OF THIS DOCUMENT ASSUMES NO RESPONSIBILITY FOR COMPLETENESS AND/OR ACCURACY OF THIS DOCUMENT. FILED IN ACCORDANCE WITH THE REQUIREMENTS OF THE EL PASO COUNTY LAND DEVELOPMENT CODE, DRAINAGE CRITERIA MANUAL VOLUMES 1 & 2, AND ENGINEERING CRITERIA MANUAL, AS AMENDED.

JENNIFER IRVINE, P.E. COUNTY ENGINEER / EGM ADMINISTRATOR DATE:
EGP-20-007

COLORADO DEPARTMENT OF PUBLIC HEALTH AND ENVIRONMENT WATER QUALITY CONTROL DIVISION WOOD - PERMITS 4300 CHERRY CREEK DRIVE SOUTH DENVER, CO 80246-1530 ATTN: PERMITS UNIT

48 HOURS BEFORE YOU DIG, CALL UTILITY LOCATORS 811 UTILITY NOTIFICATION CENTER OF COLORADO IT'S THE LAW THE LOCATIONS OF EXISTING UNDERGROUND UTILITIES ARE SHOWN IN AN APPROXIMATE WAY ONLY. THE CONTRACTOR SHALL DETERMINE THE EXACT LOCATION OF ALL EXISTING UTILITIES BEFORE COMMENCING WORK.

Table with columns: NO. REVISION, DATE, REVIEW. Includes a circular seal for Kyle R. Campbell, Civil Engineer #29794, and the date 12/13/2021.

CLASSIC CONSULTING ENGINEERS & SURVEYORS logo and project information: MIDTOWN COLLECTION AT HANNAH RIDGE FILING NO. 3 OVERLOT GRADING & EROSION CONTROL PLAN TITLE SHEET. Includes scale, sheet number (1 OF 5), and drawing by/checked by.



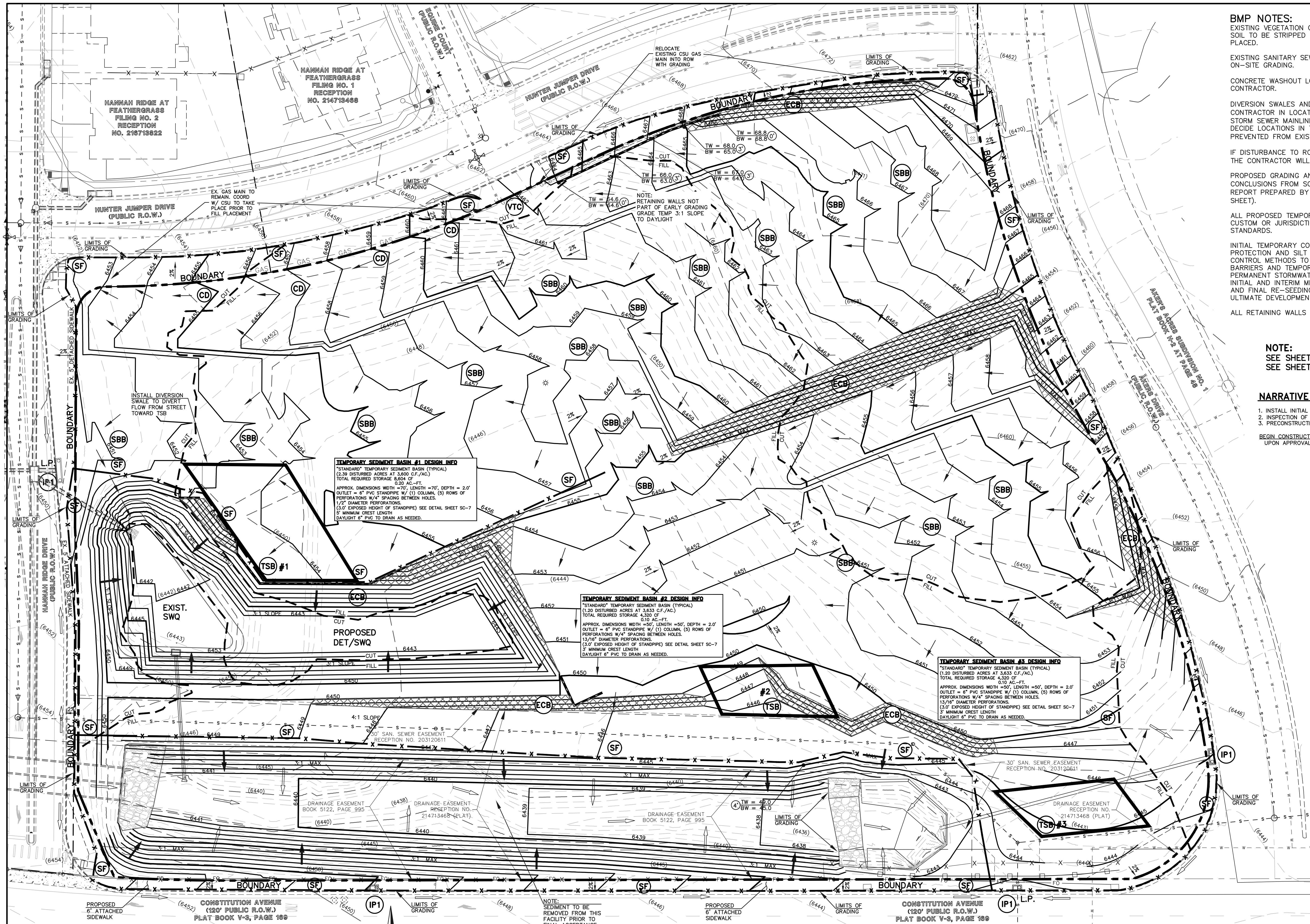

**BMP NOTES:**  
 EXISTING VEGETATION CONSISTING OF NATIVE GRASSES AND EXISTING TOP SOIL TO BE STRIPPED AND STOCK PILED PRIOR TO IMPORT MATERIAL BEING PLACED.  
 EXISTING SANITARY SEWER MAINLINE IS LOCATED WITHIN THE LIMITS OF ON-SITE GRADING.  
 CONCRETE WASHOUT LOCATION TO BE DETERMINED BY DEVELOPER / CONTRACTOR.  
 DIVERSION SWALES AND EARTH DIKES TO BE INSTALLED BY DEVELOPER / CONTRACTOR IN LOCATIONS THAT WON'T CONFLICT WITH SEWER, WATER AND STORM SEWER MAINLINE INSTALLATIONS. DEVELOPER / CONTRACTOR TO DECIDE LOCATIONS IN THE FIELD SUCH THE CONCENTRATED FLOWS WILL BE PREVENTED FROM EXISTING THE SITE AND DIRECT TOWARD TSB'S.  
 IF DISTURBANCE TO ROADWAY BMP'S OCCUR DURING UTILITY CONSTRUCTION, THE CONTRACTOR WILL IMMEDIATELY REPAIR / REPLACE BMP'S.  
 PROPOSED GRADING AND EARTHWORK CONSTRUCTION METHODS PER CONCLUSIONS FROM SOILS / GEOTECHNICAL REPORT AND GEOLOGIC HAZARD REPORT PREPARED BY ENTECH ENGINEERING. (SEE NOTE 28 ON COVER SHEET).  
 ALL PROPOSED TEMPORARY CONSTRUCTION CONTROL MEASURE DETAILS, CUSTOM OR JURISDICTIONAL DETAILS USED MUST MEET OR EXCEED EPC STANDARDS.  
 INITIAL TEMPORARY CONSTRUCTION CONTROL METHODS TO INCLUDE INLET PROTECTION AND SILT FENCING. INTERIM TEMPORARY CONSTRUCTION CONTROL METHODS TO INCLUDE VEHICLE TRACKING, ROADWAY STRAW BALE BARRIERS AND TEMPORARY SEDIMENT BASINS. FINAL METHODS TO INCLUDE PERMANENT STORMWATER QUALITY PONDS AND CONTINUAL MAINTENANCE OF INITIAL AND INTERIM METHODS AS WELL AS EROSION CONTROL BLANKETING AND FINAL RE-SEEDING ESTABLISHMENT THROUGHOUT HOME BUILDING AT ULTIMATE DEVELOPMENT.  
 ALL RETAINING WALLS TO BE MAINTAIN BY THE HOMEOWNERS ASSOCIATION.

**NOTE:**  
 SEE SHEET 4 FOR STANDARD LOT TEMPLATES  
 SEE SHEET 3, 4 & 5 FOR EROSION CONTROL DETAILS

**NARRATIVE DESCRIPTION OF CONSTRUCTION ACTIVITY:**

1. INSTALL INITIAL BMP'S
2. INSPECTION OF INITIAL BMP'S BY COUNTY STAFF
3. PRECONSTRUCTION MEETING WITH COUNTY STAFF

BEGIN CONSTRUCTION UPON APPROVAL	ACTIVITY ALL SITE ROADWAY GRADING AND UTILITY INSTALLATION	COMPLETION 6 MONTHS	EROSION CONTROL ALL SHOWN ON GRADING PLAN
----------------------------------	--	---------------------	---

**TEMPORARY SEDIMENT BASIN #1 DESIGN INFO**  
 \*STANDARD\* TEMPORARY SEDIMENT BASIN (TYPICAL)  
 (2.39 DISTURBED ACRES AT 3,600 CF./AC.)  
 TOTAL REQUIRED STORAGE 8,604 CF.  
 APPROX. DIMENSIONS WIDTH = 70', LENGTH = 70', DEPTH = 2.0'  
 OUTLET = 6" PVC STANDPIPE W/ (1) COLUMN, (5) ROWS OF PERFORATIONS W/4" SPACING BETWEEN HOLES.  
 1 1/2" DIAMETER PERFORATIONS.  
 (3.0' EXPOSED HEIGHT OF STANDPIPE) SEE DETAIL SHEET SC-7  
 3" MINIMUM CREST LENGTH  
 DAYLIGHT 6" PVC TO DRAIN AS NEEDED.

**TEMPORARY SEDIMENT BASIN #2 DESIGN INFO**  
 \*STANDARD\* TEMPORARY SEDIMENT BASIN (TYPICAL)  
 (1.20 DISTURBED ACRES AT 3,633 CF./AC.)  
 TOTAL REQUIRED STORAGE 4,320 CF.  
 APPROX. DIMENSIONS WIDTH = 50', LENGTH = 50', DEPTH = 2.0'  
 OUTLET = 6" PVC STANDPIPE W/ (1) COLUMN, (5) ROWS OF PERFORATIONS W/4" SPACING BETWEEN HOLES.  
 1 1/2" DIAMETER PERFORATIONS.  
 (3.0' EXPOSED HEIGHT OF STANDPIPE) SEE DETAIL SHEET SC-7  
 3" MINIMUM CREST LENGTH  
 DAYLIGHT 6" PVC TO DRAIN AS NEEDED.

**TEMPORARY SEDIMENT BASIN #3 DESIGN INFO**  
 \*STANDARD\* TEMPORARY SEDIMENT BASIN (TYPICAL)  
 (1.20 DISTURBED ACRES AT 3,633 CF./AC.)  
 TOTAL REQUIRED STORAGE 4,320 CF.  
 APPROX. DIMENSIONS WIDTH = 50', LENGTH = 50', DEPTH = 2.0'  
 OUTLET = 6" PVC STANDPIPE W/ (1) COLUMN, (5) ROWS OF PERFORATIONS W/4" SPACING BETWEEN HOLES.  
 1 1/2" DIAMETER PERFORATIONS.  
 (3.0' EXPOSED HEIGHT OF STANDPIPE) SEE DETAIL SHEET SC-7  
 3" MINIMUM CREST LENGTH  
 DAYLIGHT 6" PVC TO DRAIN AS NEEDED.

**LEGEND**

---	(6770)	EXISTING CONTOUR
---	6770	PROPOSED CONTOUR
---		FILING LINE
---		BOUNDARY/R.O.W. LINE
---		EXISTING FLOW DIRECTION
---		PROPOSED FLOW
---	"STD"	STANDARD LOT
---	"ALT"	ALTERNATE LOT
---		PROPOSED INLET
---		PROPOSED STORM SEWER PIPE
---	HP	PROPOSED HIGH POINT
---	LP	PROPOSED LOW POINT
---	TW = XX.XX BW = XX.XX	PROPOSED RETAINING WALL
---	ECB	EROSION CONTROL BLANKET
---	TSB	TEMPORARY SEDIMENT BASIN
---	SF	SILT FENCE
---	IP	INLET PROTECTION
---	VTC	VEHICLE TRACKING CONTROL
---	SBB	STRAW BALE BARRIER

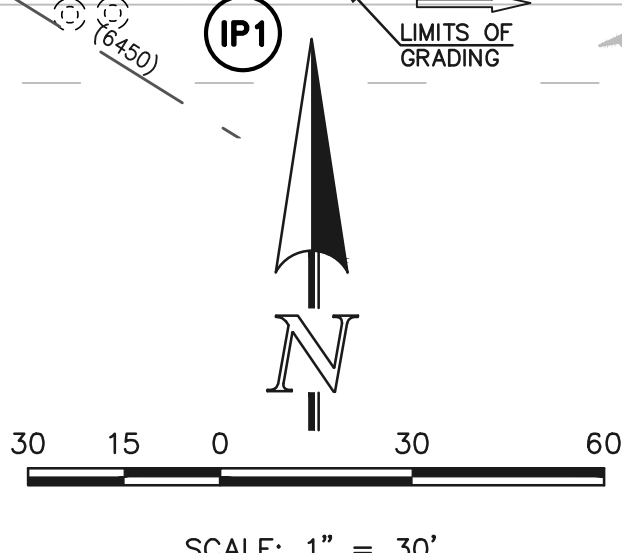

48 HOURS BEFORE YOU DIG,  
 CALL UTILITY LOCATORS  
**811**  
 UTILITY NOTIFICATION CENTER OF COLORADO  
 IT'S THE LAW

THE LOCATIONS OF EXISTING UNDERGROUND UTILITIES ARE SHOWN IN AN APPROXIMATE WAY ONLY. THE CONTRACTOR SHALL DETERMINE THE EXACT LOCATION OF ALL EXISTING UTILITIES BEFORE COMMENCING WORK. THE CONTRACTOR SHALL BE FULLY RESPONSIBLE FOR ANY AND ALL DAMAGES WHICH MIGHT BE CAUSED BY HIS FAILURE TO EXACTLY LOCATE AND PRESERVE ANY AND ALL UNDERGROUND UTILITIES.

NO. REVISION	DATE	REVIEW:

PREPARED UNDER MY SUPERVISION FOR AND ON BEHALF OF CLASSIC CONSULTING ENGINEERS & SURVEYORS, LLC

KYLE R. CAMPBELL  
 PROFESSIONAL ENGINEER #29794

12/13/2021  
 DATE

**CLASSIC**  
 CONSULTING ENGINEERS & SURVEYORS

619 N. Cascade Avenue, Suite 200  
 Colorado Springs, Colorado 80903

(719) 785-0790  
 (719) 785-0799 (Fax)

**MIDTOWN COLLECTION AT HANNAH RIDGE**  
 FILING NO. 3  
 OVERLOT GRADING AND EROSION CONTROL PLAN

DESIGNED BY	KRC	SCALE	DATE	12/06/2021
DRAWN BY	KC	(H) 1" = 30'	SHEET	2 OF 5
CHECKED BY		(V) 1" = NA	JOB NO.	1116.35

EGP-20-007

**Silt Fence (SF) SC-1**

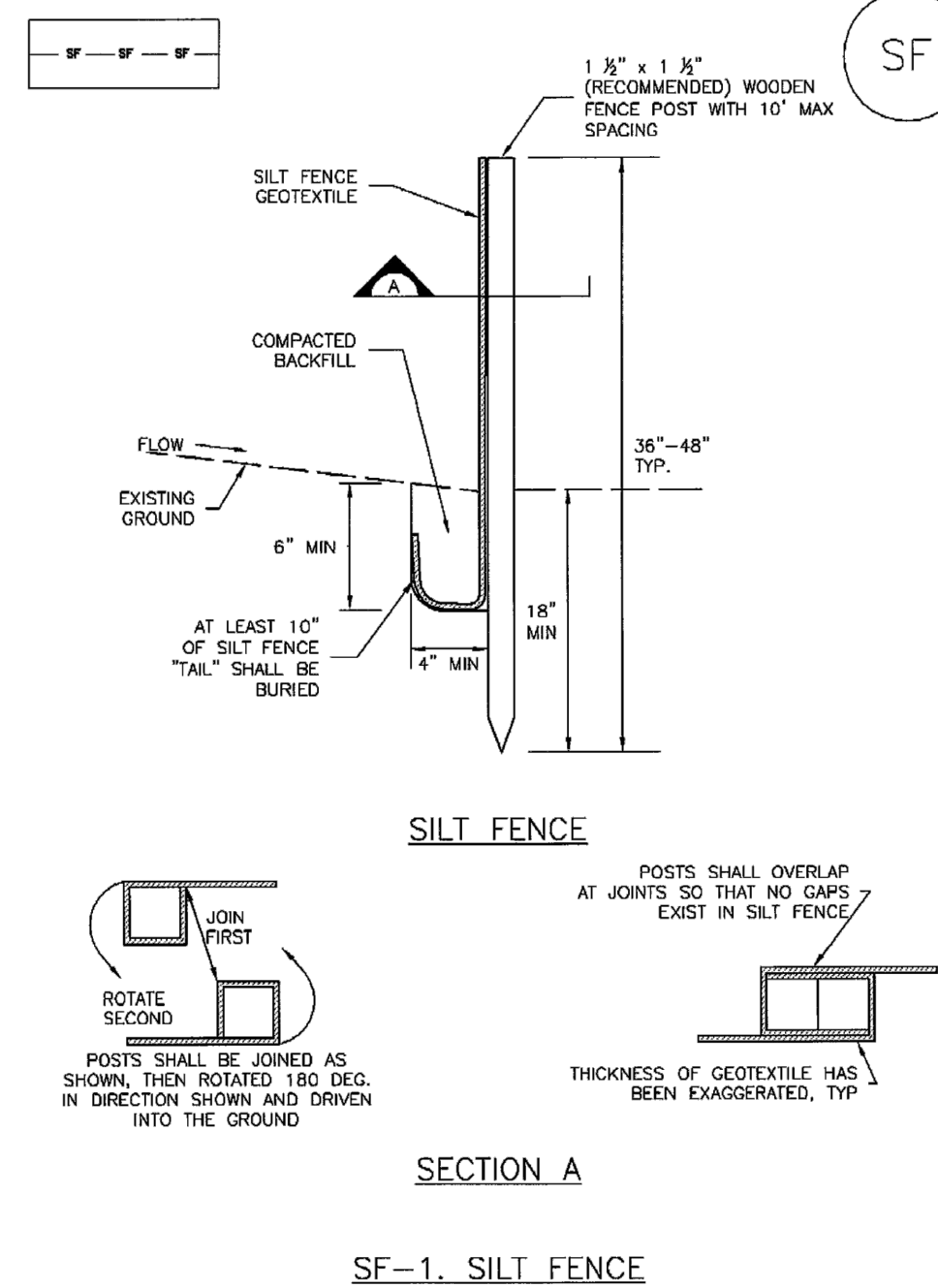

November 2010 Urban Drainage and Flood Control District Urban Storm Drainage Criteria Manual Volume 3 SF-3

**SC-1 Silt Fence (SF)**

**SILT FENCE INSTALLATION NOTES**

1. SILT FENCE MUST BE PLACED AWAY FROM THE TOE OF THE SLOPE TO ALLOW FOR WATER PONDING. SILT FENCE AT THE TOE OF A SLOPE SHOULD BE INSTALLED IN A FLAT LOCATION AT LEAST SEVERAL FEET (2-5 FT) FROM THE TOE OF THE SLOPE TO ALLOW ROOM FOR PONDING AND DEPOSITION.
2. A UNIFORM 6" X 4" ANCHOR TRENCH SHALL BE EXCAVATED USING TRENCHER OR SILT FENCE INSTALLATION DEVICE. NO ROAD GRADERS, BACKHOES, OR SIMILAR EQUIPMENT SHALL BE USED.
3. COMPACT ANCHOR TRENCH BY HAND WITH A "JUMPING JACK" OR BY WHEEL ROLLING. COMPACTION SHALL BE SUCH THAT SILT FENCE RESISTS BEING PULLED OUT OF ANCHOR TRENCH BY HAND.
4. SILT FENCE SHALL BE PULLED TIGHT AS IT IS ANCHORED TO THE STAKES. THERE SHOULD BE NO NOTICEABLE SAG BETWEEN STAKES AFTER IT HAS BEEN ANCHORED TO THE STAKES.
5. SILT FENCE FABRIC SHALL BE ANCHORED TO THE STAKES USING 1" HEAVY DUTY STAPLES OR NAILS WITH 1" HEADS. STAPLES AND NAILS SHOULD BE PLACED 3" ALONG THE FABRIC DOWN THE STAKE.
6. AT THE END OF A RUN OF SILT FENCE ALONG A CONTOUR, THE SILT FENCE SHOULD BE TURNED PERPENDICULAR TO THE CONTOUR TO CREATE A "J-HOOK." THE "J-HOOK" EXTENDING PERPENDICULAR TO THE CONTOUR SHOULD BE OF SUFFICIENT LENGTH TO KEEP RUNOFF FROM FLOWING AROUND THE END OF THE SILT FENCE (TYPICALLY 10' - 20').
7. SILT FENCE SHALL BE INSTALLED PRIOR TO ANY LAND DISTURBING ACTIVITIES.

**SILT FENCE MAINTENANCE NOTES**

1. INSPECT BMPs EACH WORKDAY, AND MAINTAIN THEM IN EFFECTIVE OPERATING CONDITION. MAINTENANCE OF BMPs SHOULD BE PROACTIVE, NOT REACTIVE. INSPECT BMPs AS SOON AS POSSIBLE (AND ALWAYS WITHIN 24 HOURS) FOLLOWING A STORM THAT CAUSES SURFACE EROSION, AND PERFORM NECESSARY MAINTENANCE.
  2. FREQUENT OBSERVATIONS AND MAINTENANCE ARE NECESSARY TO MAINTAIN BMPs IN EFFECTIVE OPERATING CONDITION. INSPECTIONS AND CORRECTIVE MEASURES SHOULD BE DOCUMENTED THOROUGHLY.
  3. WHERE BMPs HAVE FAILED, REPAIR OR REPLACEMENT SHOULD BE INITIATED UPON DISCOVERY OF THE FAILURE.
  4. SEDIMENT ACCUMULATED UPSTREAM OF THE SILT FENCE SHALL BE REMOVED AS NEEDED TO MAINTAIN THE FUNCTIONALITY OF THE BMP, TYPICALLY WHEN DEPTH OF ACCUMULATED SEDIMENTS IS APPROXIMATELY 6".
  5. REPAIR OR REPLACE SILT FENCE WHEN THERE ARE SIGNS OF WEAR, SUCH AS SAGGING, TEARING, OR COLLAPSE.
  6. SILT FENCE IS TO REMAIN IN PLACE UNTIL THE UPSTREAM DISTURBED AREA IS STABILIZED AND APPROVED BY THE LOCAL JURISDICTION, OR IS REPLACED BY AN EQUIVALENT PERIMETER SEDIMENT CONTROL BMP.
  7. WHEN SILT FENCE IS REMOVED, ALL DISTURBED AREAS SHALL BE COVERED WITH TOPSOIL, SEEDED AND MULCHED OR OTHERWISE STABILIZED AS APPROVED BY LOCAL JURISDICTION.
- (DETAILS ADAPTED FROM TOWN OF PARKER, COLORADO AND CITY OF AURORA, NOT AVAILABLE IN AUTOCAD)  
NOTE: MANY JURISDICTIONS HAVE BMP DETAILS THAT VARY FROM UDFCD STANDARD DETAILS. CONSULT WITH LOCAL JURISDICTIONS AS TO WHICH DETAIL SHOULD BE USED WHEN DIFFERENCES ARE NOTED.

SF-4 Urban Drainage and Flood Control District Urban Storm Drainage Criteria Manual Volume 3 November 2010

**SC-6 Inlet Protection (IP)**

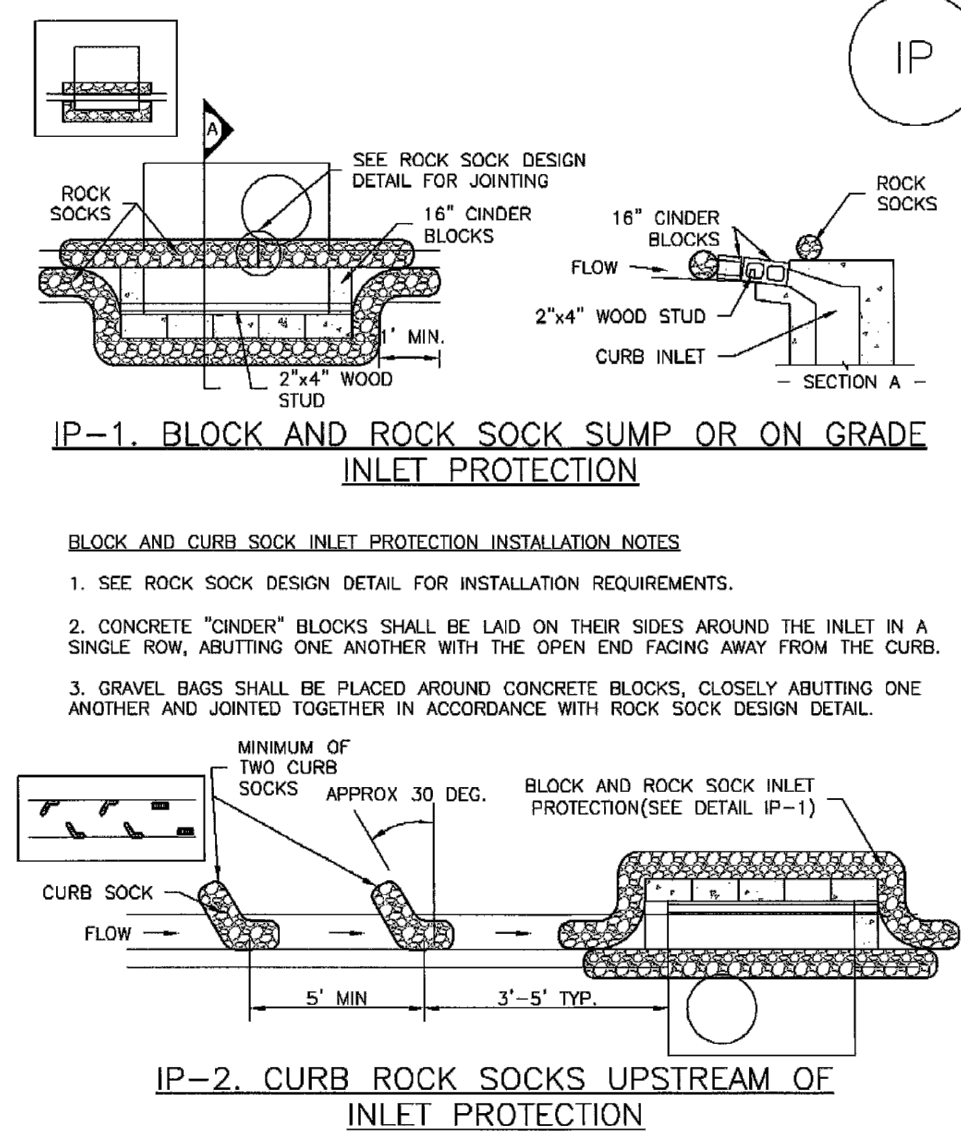

**IP-1. BLOCK AND ROCK SOCK SUMP OR ON GRADE INLET PROTECTION**

**BLOCK AND CURB SOCK INLET PROTECTION INSTALLATION NOTES**

1. SEE ROCK SOCK DESIGN DETAIL FOR INSTALLATION REQUIREMENTS.
2. CONCRETE "CINDER" BLOCKS SHALL BE LAID ON THEIR SIDES AROUND THE INLET IN A SINGLE ROW, ABUTTING ONE ANOTHER WITH THE OPEN END FACING AWAY FROM THE CURB.
3. GRAVEL BAGS SHALL BE PLACED AROUND CONCRETE BLOCKS, CLOSELY ABUTTING ONE ANOTHER AND JOINED TOGETHER IN ACCORDANCE WITH ROCK SOCK DESIGN DETAIL.

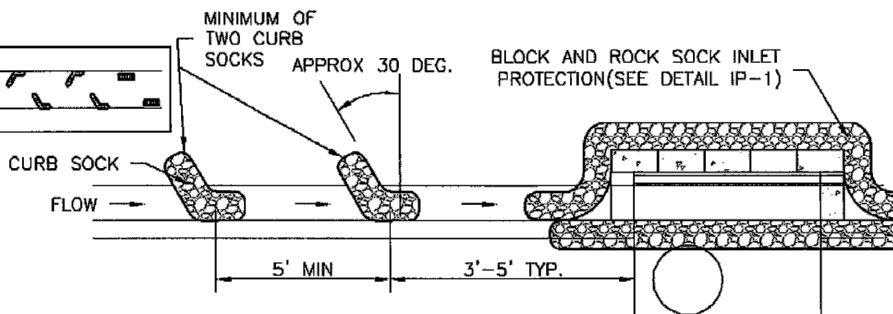

**IP-2. CURB ROCK SOCKS UPSTREAM OF INLET PROTECTION**

**CURB ROCK SOCK INLET PROTECTION INSTALLATION NOTES**

1. SEE ROCK SOCK DESIGN DETAIL FOR INSTALLATION REQUIREMENTS.
2. PLACEMENT OF THE SOCK SHALL BE APPROXIMATELY 30 DEGREES FROM PERPENDICULAR IN THE OPPOSITE DIRECTION OF FLOW.
3. SOCKS ARE TO BE FLUSH WITH THE CURB AND SPACED A MINIMUM OF 5 FEET APART.
4. AT LEAST TWO CURB SOCKS IN SERIES ARE REQUIRED UPSTREAM OF ON-GRADE INLETS.

IP-4 Urban Drainage and Flood Control District Urban Storm Drainage Criteria Manual Volume 3 August 2013

**SC-6 Inlet Protection (IP)**

**GENERAL INLET PROTECTION INSTALLATION NOTES**

1. SEE PLAN VIEW FOR:
    - LOCATION OF INLET PROTECTION.
    - TYPE OF INLET PROTECTION (IP-1, IP-2, IP-3, IP-4, IP-5, IP-6)
  2. INLET PROTECTION SHALL BE INSTALLED PROMPTLY AFTER INLET CONSTRUCTION OR PAVING IS COMPLETE (TYPICALLY WITHIN 48 HOURS). IF A RAINFALL/RUNOFF EVENT IS FORECAST, INSTALL INLET PROTECTION PRIOR TO ONSET OF EVENT.
  3. MANY JURISDICTIONS HAVE BMP DETAILS THAT VARY FROM UDFCD STANDARD DETAILS. CONSULT WITH LOCAL JURISDICTIONS AS TO WHICH DETAIL SHOULD BE USED WHEN DIFFERENCES ARE NOTED.
- INLET PROTECTION MAINTENANCE NOTES**
1. INSPECT BMPs EACH WORKDAY, AND MAINTAIN THEM IN EFFECTIVE OPERATING CONDITION. MAINTENANCE OF BMPs SHOULD BE PROACTIVE, NOT REACTIVE. INSPECT BMPs AS SOON AS POSSIBLE (AND ALWAYS WITHIN 24 HOURS) FOLLOWING A STORM THAT CAUSES SURFACE EROSION, AND PERFORM NECESSARY MAINTENANCE.
  2. FREQUENT OBSERVATIONS AND MAINTENANCE ARE NECESSARY TO MAINTAIN BMPs IN EFFECTIVE OPERATING CONDITION. INSPECTIONS AND CORRECTIVE MEASURES SHOULD BE DOCUMENTED THOROUGHLY.
  3. WHERE BMPs HAVE FAILED, REPAIR OR REPLACEMENT SHOULD BE INITIATED UPON DISCOVERY OF THE FAILURE.
  4. SEDIMENT ACCUMULATED UPSTREAM OF INLET PROTECTION SHALL BE REMOVED AS NECESSARY TO MAINTAIN BMP EFFECTIVENESS, TYPICALLY WHEN STORAGE VOLUME REACHES 50% OF CAPACITY, A DEPTH OF 6" WHEN SILT FENCE IS USED, OR 1/4 OF THE HEIGHT FOR STRAW BALES.
  5. INLET PROTECTION IS TO REMAIN IN PLACE UNTIL THE UPSTREAM DISTURBED AREA IS PERMANENTLY STABILIZED, UNLESS THE LOCAL JURISDICTION APPROVES EARLIER REMOVAL OF INLET PROTECTION IN STREETS.
  6. WHEN INLET PROTECTION AT AREA INLETS IS REMOVED, THE DISTURBED AREA SHALL BE COVERED WITH TOP SOIL, SEEDED AND MULCHED, OR OTHERWISE STABILIZED IN A MANNER APPROVED BY THE LOCAL JURISDICTION.

(DETAILS ADAPTED FROM TOWN OF PARKER, COLORADO AND CITY OF AURORA, NOT AVAILABLE IN AUTOCAD)  
NOTE: MANY JURISDICTIONS HAVE BMP DETAILS THAT VARY FROM UDFCD STANDARD DETAILS. CONSULT WITH LOCAL JURISDICTIONS AS TO WHICH DETAIL SHOULD BE USED WHEN DIFFERENCES ARE NOTED.

NOTE: THE DETAILS INCLUDED WITH THIS FACT SHEET SHOW COMMONLY USED, CONVENTIONAL METHODS OF INLET PROTECTION IN THE DENVER METROPOLITAN AREA. THERE ARE MANY PROPRIETARY INLET PROTECTION METHODS ON THE MARKET. UDFCD NEITHER ENDORSES NOR DISCOURAGES USE OF PROPRIETARY INLET PROTECTION; HOWEVER, IN THE EVENT PROPRIETARY METHODS ARE USED, THE APPROPRIATE DETAIL FROM THE MANUFACTURER MUST BE INCLUDED IN THE BMP AND THE BMP MUST BE INSTALLED AND MAINTAINED AS SHOWN IN THE MANUFACTURER'S DETAILS.

NOTE: SOME MUNICIPALITIES DISCOURAGE OR PROHIBIT THE USE OF STRAW BALES FOR INLET PROTECTION. CHECK WITH LOCAL JURISDICTION TO DETERMINE IF STRAW BALE INLET PROTECTION IS ACCEPTABLE.

IP-8 Urban Drainage and Flood Control District Urban Storm Drainage Criteria Manual Volume 3 August 2013

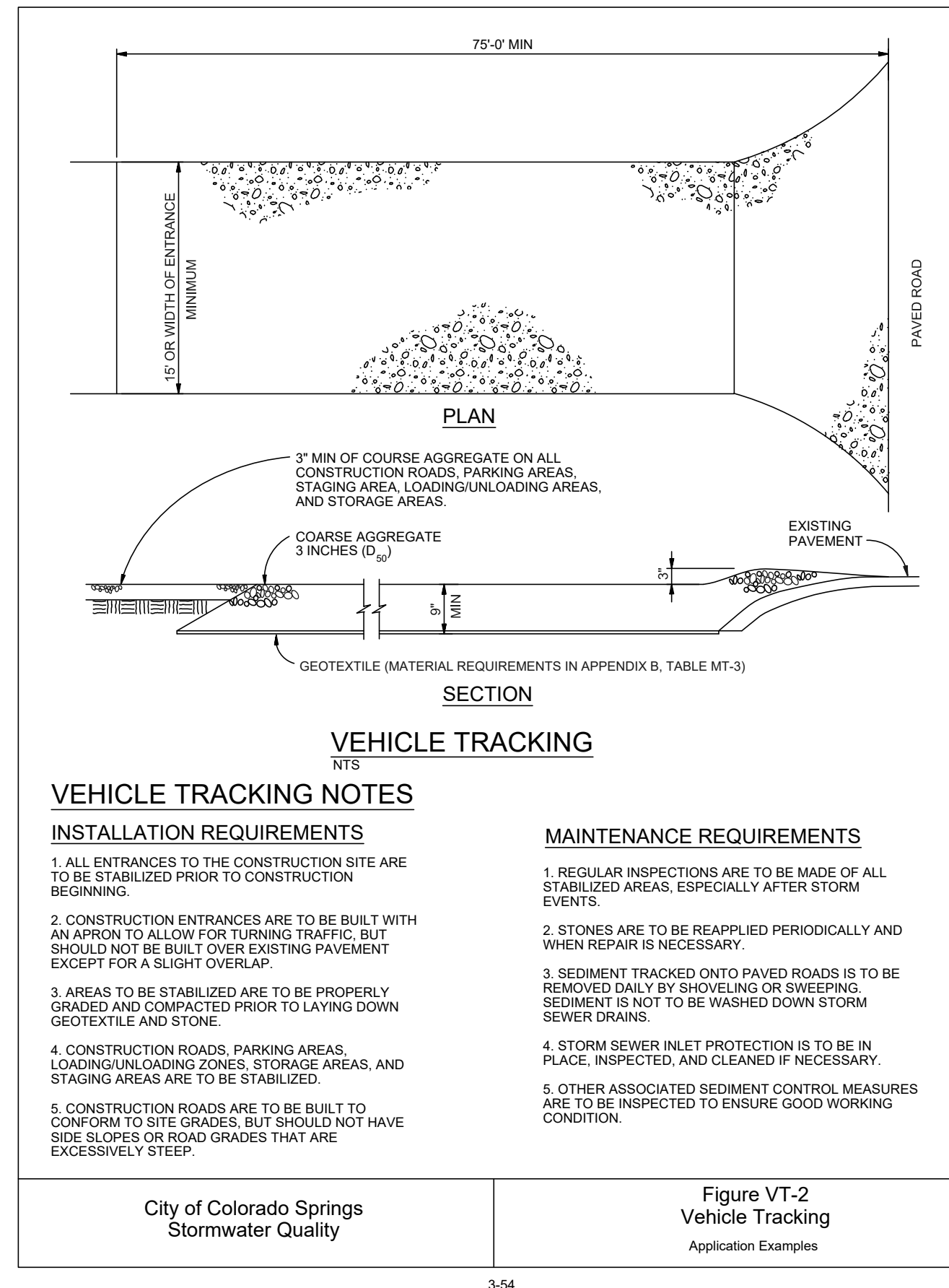

**VEHICLE TRACKING NOTES**

**INSTALLATION REQUIREMENTS**

1. ALL ENTRANCES TO THE CONSTRUCTION SITE ARE TO BE STABILIZED PRIOR TO CONSTRUCTION BEGINNING.
2. CONSTRUCTION ENTRANCES ARE TO BE BUILT WITH AN APRON TO ALLOW FOR TURNING TRAFFIC, BUT SHOULD NOT BE BUILT OVER EXISTING PAVEMENT EXCEPT FOR A SLIGHT OVERLAP.
3. AREAS TO BE STABILIZED ARE TO BE PROPERLY GRADED AND COMPACTED PRIOR TO LAYING DOWN GEOTEXTILE AND STONE.
4. CONSTRUCTION ROADS, PARKING AREAS, LOADING/UNLOADING ZONES, STORAGE AREAS, AND STAGING AREAS ARE TO BE STABILIZED.
5. CONSTRUCTION ROADS ARE TO BE BUILT TO CONFORM TO SITE GRADES, BUT SHOULD NOT HAVE SIDE SLOPES OR ROAD GRADES THAT ARE EXCESSIVELY STEEP.

**MAINTENANCE REQUIREMENTS**

1. REGULAR INSPECTIONS ARE TO BE MADE OF ALL STABILIZED AREAS, ESPECIALLY AFTER STORM EVENTS.
2. STONES ARE TO BE REAPPLIED PERIODICALLY AND WHEN REPAIR IS NECESSARY.
3. SEDIMENT TRACKED ONTO PAVED ROADS IS TO BE REMOVED DAILY BY SHOVELING OR SWEEPING. SEDIMENT IS NOT TO BE WASHED DOWN STORM SEWER DRAINS.
4. STORM SEWER INLET PROTECTION IS TO BE IN PLACE, INSPECTED, AND CLEANED IF NECESSARY.
5. OTHER ASSOCIATED SEDIMENT CONTROL MEASURES ARE TO BE INSPECTED TO ENSURE GOOD WORKING CONDITION.

City of Colorado Springs Stormwater Quality Figure VT-2 Vehicle Tracking Application Examples 3-54

**SM-4 Vehicle Tracking Control (VTC)**

**STABILIZED CONSTRUCTION ENTRANCE/EXIT INSTALLATION NOTES**

1. SEE PLAN VIEW FOR:
    - LOCATION OF CONSTRUCTION ENTRANCE(S)/EXIT(S).
    - TYPE OF CONSTRUCTION ENTRANCE(S)/EXIT(S) (WITH/WITHOUT WHEEL WASH, CONSTRUCTION MAT OR TRM).
  2. CONSTRUCTION MAT OR TRM STABILIZED CONSTRUCTION ENTRANCES ARE ONLY TO BE USED ON SHORT DURATION PROJECTS (TYPICALLY RANGING FROM A WEEK TO A MONTH) WHERE THERE WILL BE LIMITED VEHICULAR ACCESS.
  3. A STABILIZED CONSTRUCTION ENTRANCE/EXIT SHALL BE LOCATED AT ALL ACCESS POINTS WHERE VEHICLES ACCESS THE CONSTRUCTION SITE FROM PAVED RIGHT-OF-WAYS.
  4. STABILIZED CONSTRUCTION ENTRANCE/EXIT SHALL BE INSTALLED PRIOR TO ANY LAND DISTURBING ACTIVITIES.
  5. A NON-WOVEN GEOTEXTILE FABRIC SHALL BE PLACED UNDER THE STABILIZED CONSTRUCTION ENTRANCE/EXIT PRIOR TO THE PLACEMENT OF ROCK.
  6. UNLESS OTHERWISE SPECIFIED BY LOCAL JURISDICTION, ROCK SHALL CONSIST OF DOT SECT. #703, AASHTO #3 COARSE AGGREGATE OR 6" (MINUS) ROCK.
- STABILIZED CONSTRUCTION ENTRANCE/EXIT MAINTENANCE NOTES**
1. INSPECT BMPs EACH WORKDAY, AND MAINTAIN THEM IN EFFECTIVE OPERATING CONDITION. MAINTENANCE OF BMPs SHOULD BE PROACTIVE, NOT REACTIVE. INSPECT BMPs AS SOON AS POSSIBLE (AND ALWAYS WITHIN 24 HOURS) FOLLOWING A STORM THAT CAUSES SURFACE EROSION, AND PERFORM NECESSARY MAINTENANCE.
  2. FREQUENT OBSERVATIONS AND MAINTENANCE ARE NECESSARY TO MAINTAIN BMPs IN EFFECTIVE OPERATING CONDITION. INSPECTIONS AND CORRECTIVE MEASURES SHOULD BE DOCUMENTED THOROUGHLY.
  3. WHERE BMPs HAVE FAILED, REPAIR OR REPLACEMENT SHOULD BE INITIATED UPON DISCOVERY OF THE FAILURE.
  4. ROCK SHALL BE REAPPLIED OR REGRADED AS NECESSARY TO THE STABILIZED ENTRANCE/EXIT TO MAINTAIN A CONSISTENT DEPTH.
  5. SEDIMENT TRACKED ONTO PAVED ROADS IS TO BE REMOVED THROUGHOUT THE DAY AND AT THE END OF THE DAY BY SHOVELING OR SWEEPING. SEDIMENT MAY NOT BE WASHED DOWN STORM SEWER DRAINS.
- (DETAILS ADAPTED FROM CITY OF BROOMFIELD, COLORADO, NOT AVAILABLE IN AUTOCAD)

VTC-6 Urban Drainage and Flood Control District Urban Storm Drainage Criteria Manual Volume 3 November 2010

**SC-3 Straw Bale Barrier (SBB)**

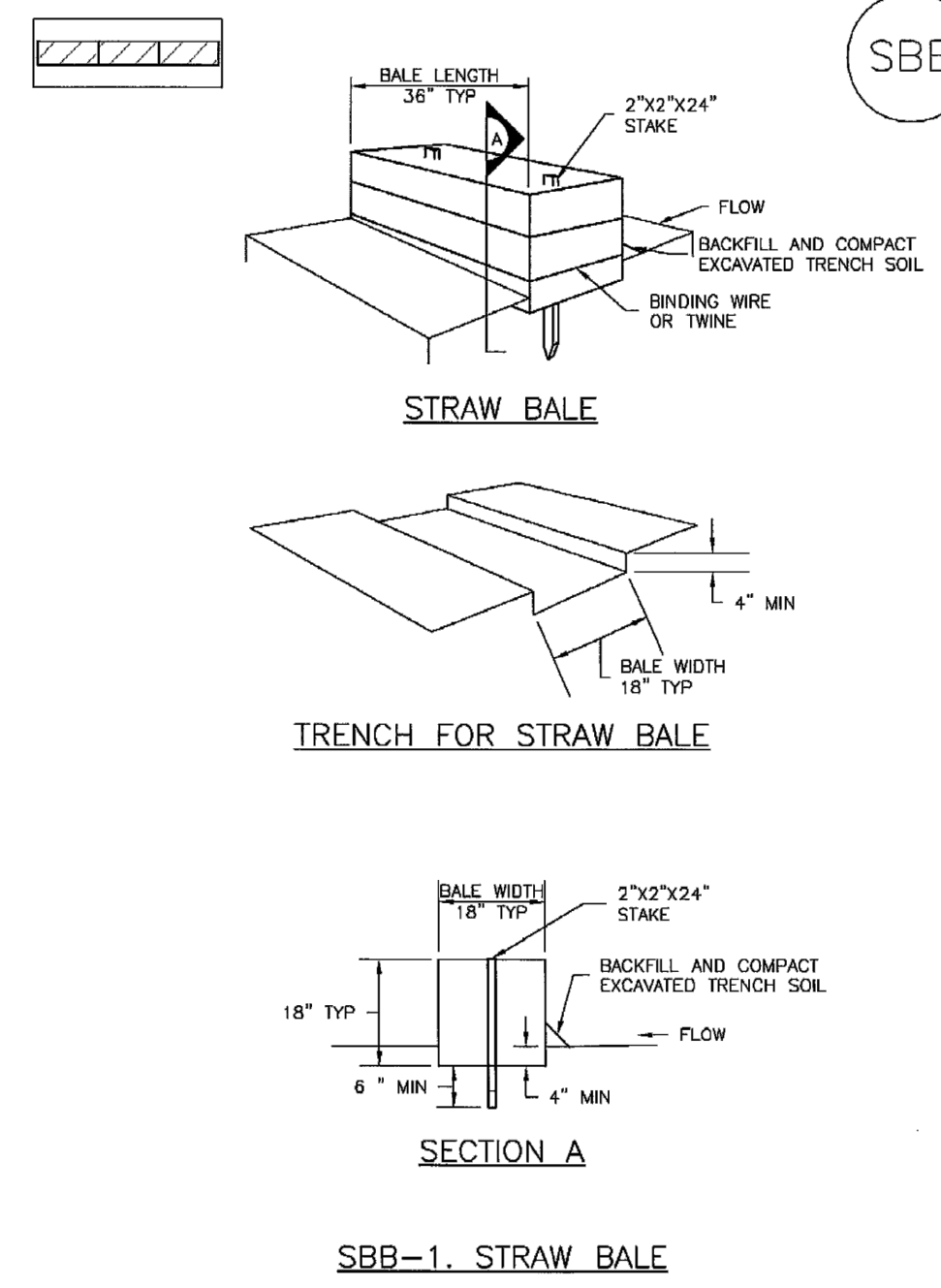

SBB-2 Urban Drainage and Flood Control District Urban Storm Drainage Criteria Manual Volume 3 November 2010

**SC-3 Straw Bale Barrier (SBB)**

**STRAW BALE INSTALLATION NOTES**

1. SEE PLAN VIEW FOR:
  - LOCATION(S) OF STRAW BALES.
2. STRAW BALES SHALL CONSIST OF CERTIFIED WEED FREE STRAW OR HAY. LOCAL JURISDICTIONS MAY REQUIRE PROOF THAT BALES ARE WEED FREE.
3. STRAW BALES SHALL CONSIST OF APPROXIMATELY 5 CUBIC FEET OF STRAW OR HAY AND WEIGH NOT LESS THAN 35 POUNDS.
4. WHEN STRAW BALES ARE USED IN SERIES AS A BARRIER, THE END OF EACH BALE SHALL BE TIGHTLY ABUTTING ONE ANOTHER.
5. STRAW BALE DIMENSIONS SHALL BE APPROXIMATELY 36"x18"x18".
6. A UNIFORM ANCHOR TRENCH SHALL BE EXCAVATED TO A DEPTH OF 4". STRAW BALES SHALL BE PLACED SO THAT BINDING TWINE IS ENCOMPASSING THE VERTICAL SIDES OF THE BALES(S). ALL EXCAVATED SOIL SHALL BE PLACED ON THE UPHILL SIDE OF THE STRAW BALE(S) AND COMPACTED.
7. TWO (2) WOODEN STAKES SHALL BE USED TO HOLD EACH BALE IN PLACE. WOODEN STAKES SHALL BE 2"x2"x24". WOODEN STAKES SHALL BE DRIVEN 6" INTO THE GROUND.

**STRAW BALE MAINTENANCE NOTES**

1. INSPECT BMPs EACH WORKDAY, AND MAINTAIN THEM IN EFFECTIVE OPERATING CONDITION. MAINTENANCE OF BMPs SHOULD BE PROACTIVE, NOT REACTIVE. INSPECT BMPs AS SOON AS POSSIBLE (AND ALWAYS WITHIN 24 HOURS) FOLLOWING A STORM THAT CAUSES SURFACE EROSION, AND PERFORM NECESSARY MAINTENANCE.
  2. FREQUENT OBSERVATIONS AND MAINTENANCE ARE NECESSARY TO MAINTAIN BMPs IN EFFECTIVE OPERATING CONDITION. INSPECTIONS AND CORRECTIVE MEASURES SHOULD BE DOCUMENTED THOROUGHLY.
  3. WHERE BMPs HAVE FAILED, REPAIR OR REPLACEMENT SHOULD BE INITIATED UPON DISCOVERY OF THE FAILURE.
  4. STRAW BALES SHALL BE REPLACED IF THEY BECOME HEAVILY SOILED, ROTTEN, OR DAMAGED BEYOND REPAIR.
  5. SEDIMENT ACCUMULATED UPSTREAM OF STRAW BALE BARRIER SHALL BE REMOVED AS NEEDED TO MAINTAIN FUNCTIONALITY OF THE BMP. TYPICALLY WHEN DEPTH OF ACCUMULATED SEDIMENTS IS APPROXIMATELY 1/4 OF THE HEIGHT OF THE STRAW BALE BARRIER.
  6. STRAW BALES ARE TO REMAIN IN PLACE UNTIL THE UPSTREAM DISTURBED AREA IS STABILIZED AND APPROVED BY THE LOCAL JURISDICTION.
  7. WHEN STRAW BALES ARE REMOVED, ALL DISTURBED AREAS SHALL BE COVERED WITH TOPSOIL, SEEDED AND MULCHED OR OTHERWISE STABILIZED AS APPROVED BY LOCAL JURISDICTION.
- (DETAILS ADAPTED FROM TOWN OF PARKER, COLORADO, NOT AVAILABLE IN AUTOCAD)  
NOTE: MANY JURISDICTIONS HAVE BMP DETAILS THAT VARY FROM UDFCD STANDARD DETAILS. CONSULT WITH LOCAL JURISDICTIONS AS TO WHICH DETAIL SHOULD BE USED WHEN DIFFERENCES ARE NOTED.

SBB-3 Urban Drainage and Flood Control District Urban Storm Drainage Criteria Manual Volume 3 November 2010

EGP-20-007

<p>48 HOURS BEFORE YOU DIG, CALL UTILITY LOCATORS</p> <p><b>811</b></p> <p>UTILITY NOTIFICATION CENTER OF COLORADO</p> <p>IT'S THE LAW</p> <p>THE LOCATIONS OF EXISTING UNDERGROUND UTILITIES ARE SHOWN IN AN APPROXIMATE WAY ONLY. THE CONTRACTOR SHALL DETERMINE THE EXACT LOCATION OF ALL EXISTING UTILITIES BEFORE COMMENCING WORK. THE CONTRACTOR SHALL BE FULLY RESPONSIBLE FOR ANY AND ALL DAMAGES WHICH MIGHT BE CAUSED BY HIS FAILURE TO EXACTLY LOCATE AND PRESERVE ANY AND ALL UNDERGROUND UTILITIES.</p>	<p>NO. REVISION</p>	<p>DATE</p>	<p>REVIEW:</p> <p>PREPARED UNDER MY PROFESSIONAL SUPERVISION FOR AND ON BEHALF OF CLASSIC CONSULTING ENGINEERS &amp; SURVEYORS, LLC</p> <p>KYLE R. CAMPBELL, #29794</p> <p>12/13/2021</p>	<p>MIDTOWN COLLECTION AT HANNAH RIDGE</p> <p>FILING NO. 3</p> <p>OVERLOT GRADING AND EROSION CONTROL PLAN</p> <p>DETAILS</p> <p>DESIGNED BY: KRC SCALE: DATE: 12/06/2021</p> <p>DRAWN BY: KC (H) 1"= N/A SHEET 3 OF 5</p> <p>CHECKED BY: (V) 1"= N/A JOB NO. 1116.35</p>
	<p>CLASSIC CONSULTING ENGINEERS &amp; SURVEYORS</p> <p>619 N. Cascade Avenue, Suite 200 Colorado Springs, Colorado 80903 (719) 785-0790 (719) 785-0799 (Fax)</p>			<p>CLASSIC CONSULTING ENGINEERS &amp; SURVEYORS</p>

Table 14-12. Recommended Seed Mix for all other Soils in Upland Areas

Table with 6 columns: Common Name (Variety), Scientific Name, Growth Season, Growth Form, Seeds/Lb, Lbs PLS/Acre Drilled, and Lbs PLS/Acre Broadcast or Hydroseeded. Lists various grasses and wildflowers like Sheep fescue, Canby bluegrass, Thickspike wheatgrass, etc.

The seed mixes in Tables 14-9 through 14-12 include recommended wildflowers that can be sown at the same time or after the grass seed mix. Table 14-13 includes a general wildflower seed mix that can be used in sunny locations.

City of Colorado Springs Drainage Criteria Manual, Volume 1

Concrete Washout Area (CWA) MM-1

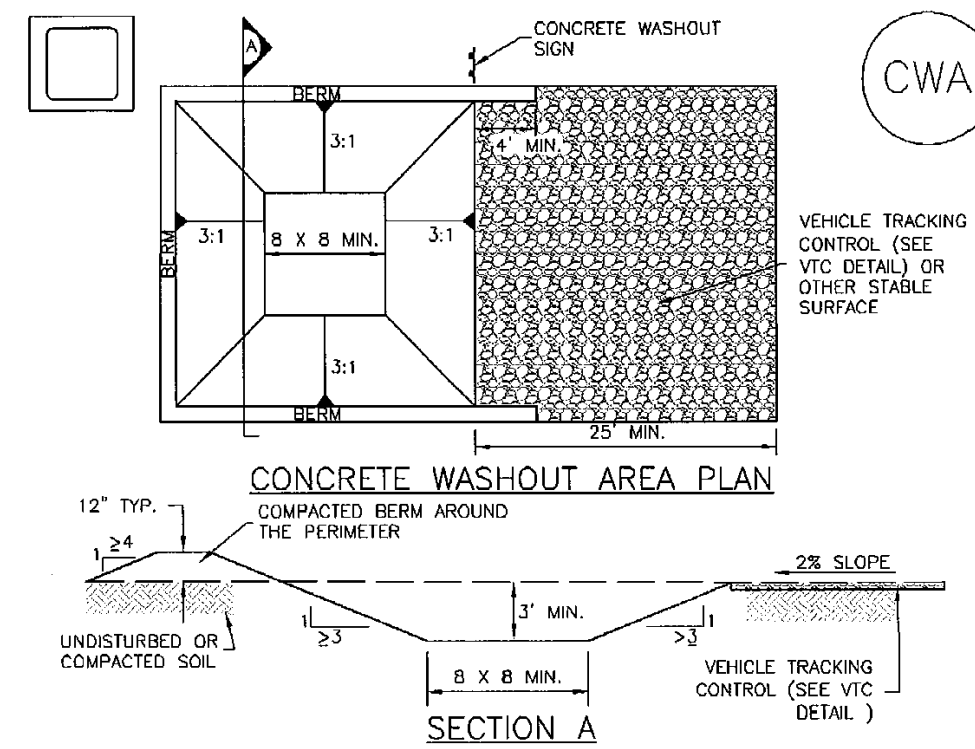

CWA-1. CONCRETE WASHOUT AREA
CWA INSTALLATION NOTES
1. SEE PLAN VIEW FOR CWA INSTALLATION LOCATION.
2. DO NOT LOCATE AN UNLINED CWA WITHIN 400' OF ANY NATURAL DRAINAGE PATHWAY OR WATERBODY...

November 2010 Urban Drainage and Flood Control District Urban Storm Drainage Criteria Manual Volume 3 CWA-3

Sediment Basin (SB) SC-7

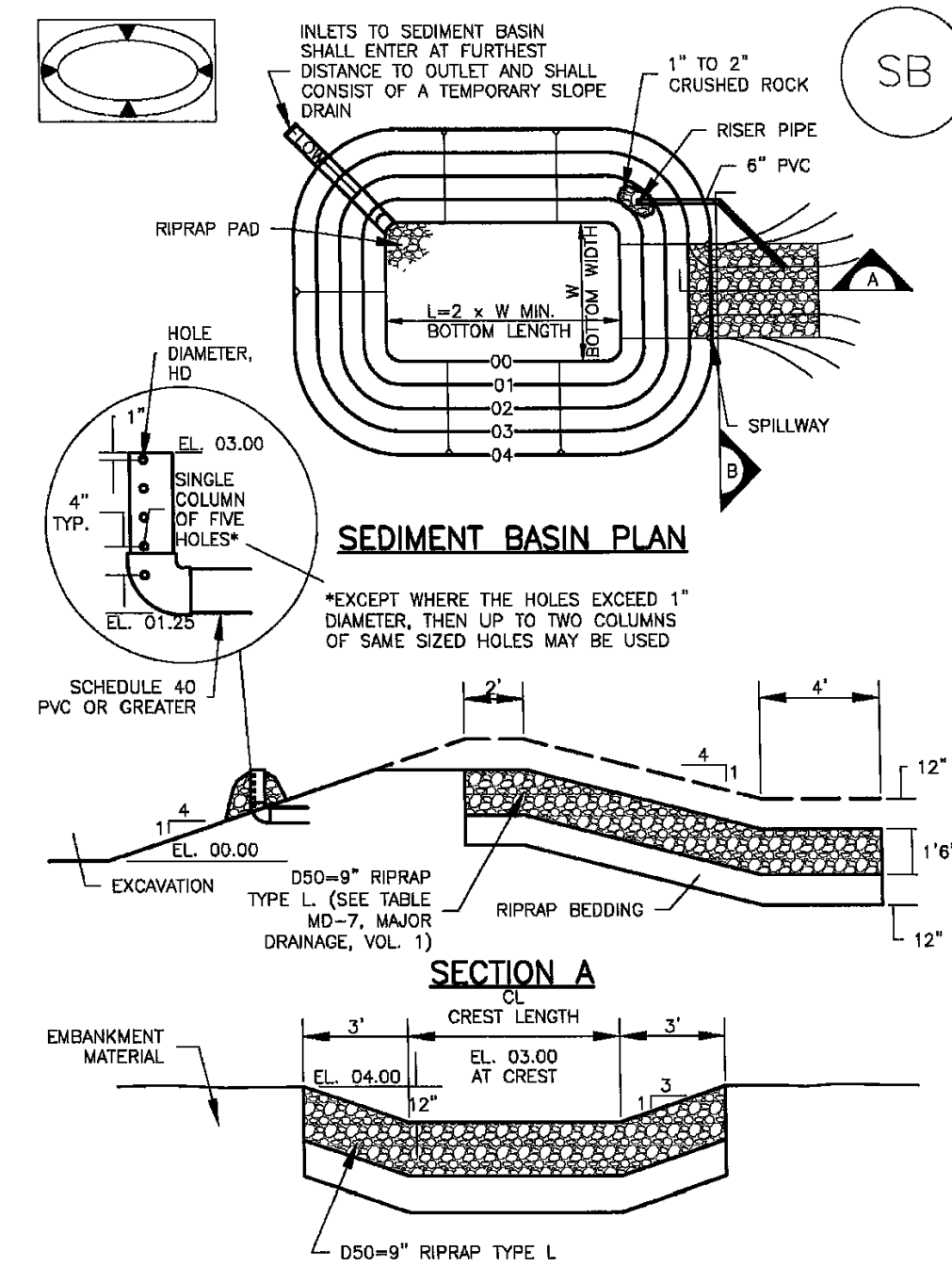

August 2013 Urban Drainage and Flood Control District Urban Storm Drainage Criteria Manual Volume 3 SB-5

Sediment Basin (SB) SC-7

SEDIMENT BASIN MAINTENANCE NOTES

- 1. INSPECT BMPs EACH WORKDAY, AND MAINTAIN THEM IN EFFECTIVE OPERATING CONDITION. MAINTENANCE OF BMPs SHOULD BE PROACTIVE, NOT REACTIVE. INSPECT BMPs AS SOON AS POSSIBLE...
2. FREQUENT OBSERVATIONS AND MAINTENANCE ARE NECESSARY TO MAINTAIN BMP IN EFFECTIVE OPERATING CONDITION...
3. WHERE BMPs HAVE FAILED, REPAIR OR REPLACEMENT SHOULD BE INITIATED UPON DISCOVERY OF THE FAILURE.

(DETAILS ADAPTED FROM DOUGLAS COUNTY, COLORADO)

NOTE: MANY JURISDICTIONS HAVE BMP DETAILS THAT VARY FROM UDFCD STANDARD DETAILS. CONSULT WITH LOCAL JURISDICTIONS AS TO WHICH DETAIL SHOULD BE USED WHEN DIFFERENCES ARE NOTED.

August 2013 Urban Drainage and Flood Control District Urban Storm Drainage Criteria Manual Volume 3 SB-7

Check Dams (CD) EC-12

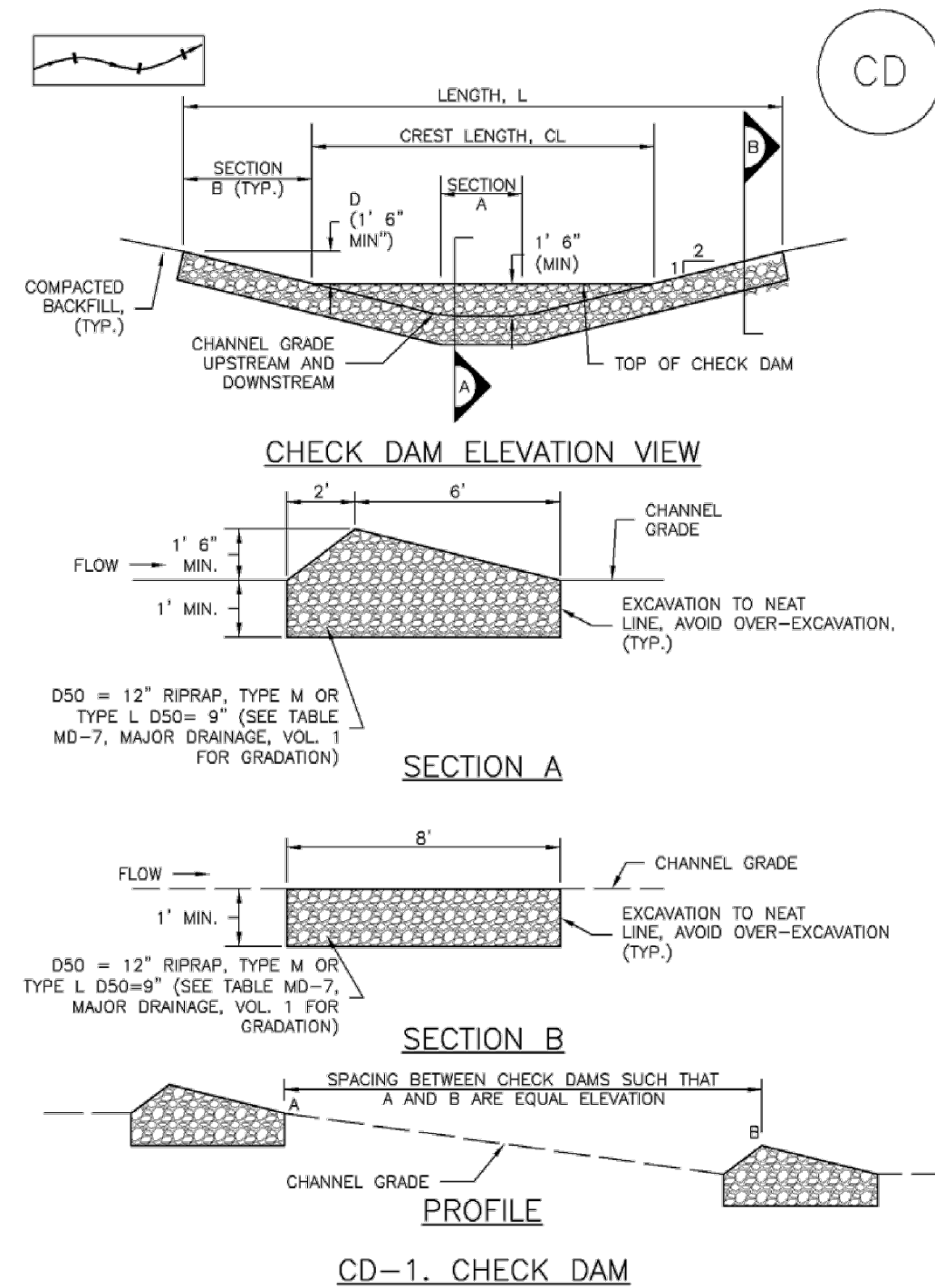

November 2010 Urban Drainage and Flood Control District Urban Storm Drainage Criteria Manual Volume 3 CD-3

Concrete Washout Area (CWA) MM-1

- CWA MAINTENANCE NOTES
1. INSPECT BMPs EACH WORKDAY, AND MAINTAIN THEM IN EFFECTIVE OPERATING CONDITION. MAINTENANCE OF BMPs SHOULD BE PROACTIVE, NOT REACTIVE. INSPECT BMPs AS SOON AS POSSIBLE...
2. FREQUENT OBSERVATIONS AND MAINTENANCE ARE NECESSARY TO MAINTAIN BMP IN EFFECTIVE OPERATING CONDITION...

November 2010 Urban Drainage and Flood Control District Urban Storm Drainage Criteria Manual Volume 3 CWA-4

Sediment Basin (SB) SC-7

Table SB-1. SIZING INFORMATION FOR STANDARD SEDIMENT BASIN. Columns: Upstream Drainage Area, Basin Bottom Width, Spillway Crest Length, Hole Diameter.

SEDIMENT BASIN INSTALLATION NOTES

- 1. SEE PLAN VIEW FOR LOCATION OF SEDIMENT BASIN.
2. FOR STANDARD BASIN, BOTTOM DIMENSION MAY BE MODIFIED AS LONG AS BOTTOM AREA IS NOT REDUCED.
3. SEDIMENT BASINS SHALL BE INSTALLED PRIOR TO ANY OTHER LAND-DISTURBING ACTIVITY THAT RELIES ON ON BASINS AS A STORMWATER CONTROL.

August 2013 Urban Drainage and Flood Control District Urban Storm Drainage Criteria Manual Volume 3 SB-6

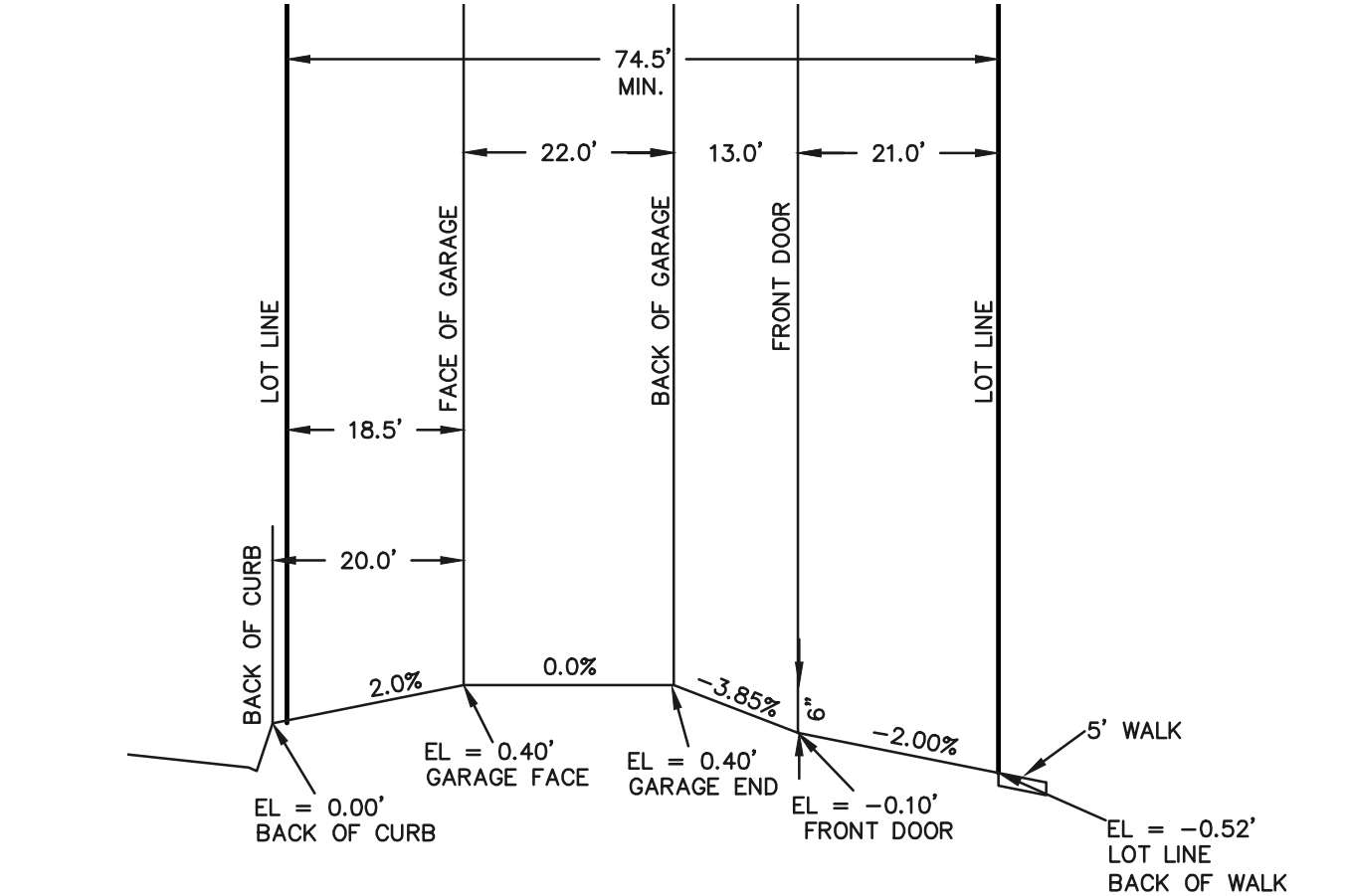

ALT-FRONT ENTRY ELEVATED ABOVE GRADE

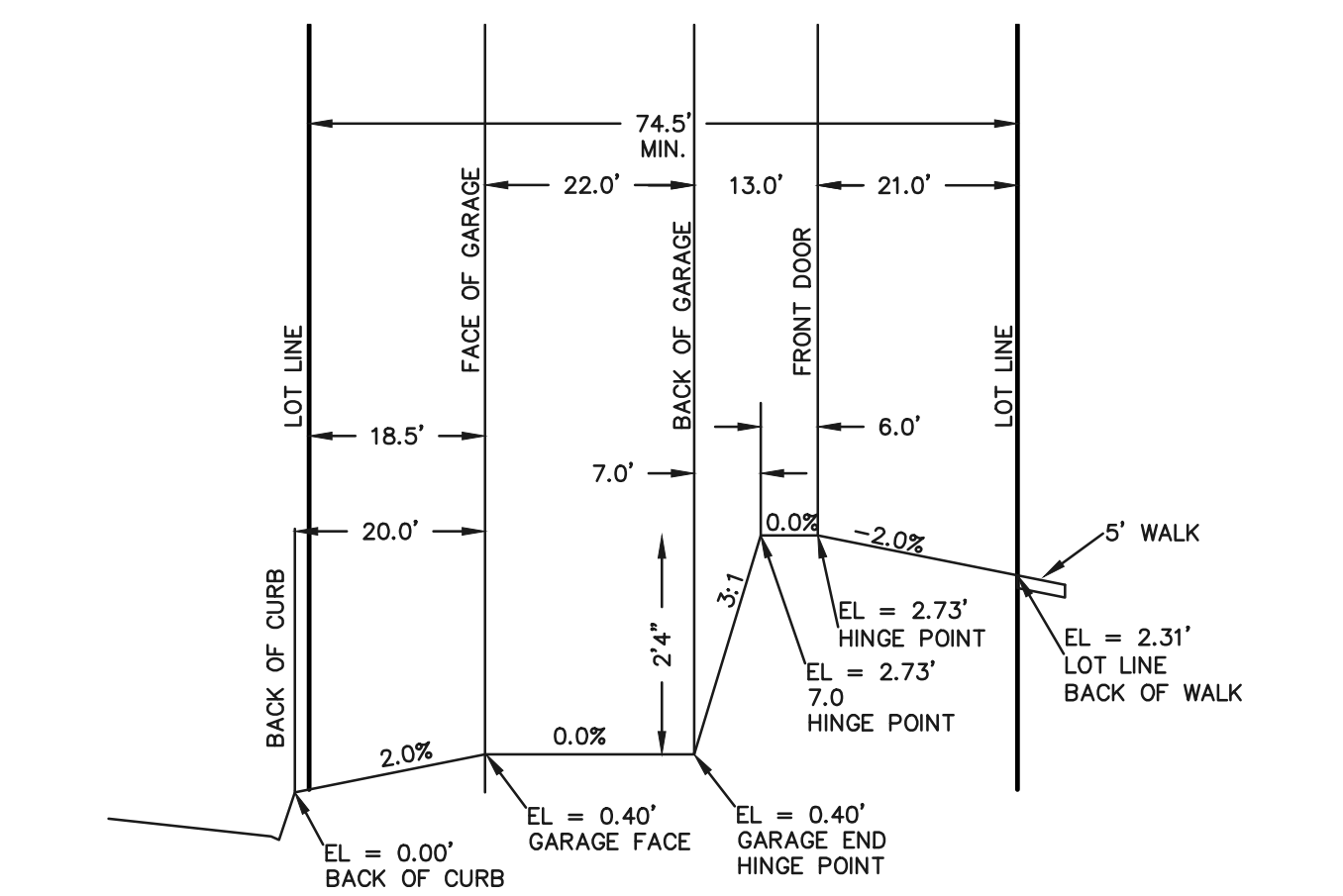

STD-FRONT ENTRY AT GRADE LOT OVERLOT TEMPLATE

EGP-20-007

48 HOURS BEFORE YOU DIG, CALL UTILITY LOCATORS 811
UTILITY NOTIFICATION CENTER OF COLORADO IT'S THE LAW

Table with 3 columns: NO. REVISION, DATE, REVIEW. Includes a professional seal for Kyle R. Campbell.

REVIEW:
PREPARED UNDER MY SUPERVISION FOR AND ON BEHALF OF CLASSIC CONSULTING ENGINEERS & SURVEYORS, LLC
KYLE R. CAMPBELL, #29794, DATE 12/13/2021

CLASSIC CONSULTING ENGINEERS & SURVEYORS logo and address: 619 N. Cascade Avenue, Suite 200, Colorado Springs, Colorado 80903

Project information table: MIDTOWN COLLECTION AT HANNAH RIDGE FILING NO. 3, OVERLOT GRADING AND EROSION CONTROL PLAN DETAILS. Includes designer, scale, date, sheet number, and job number.

**EC-6 Rolled Erosion Control Products (RECP)**

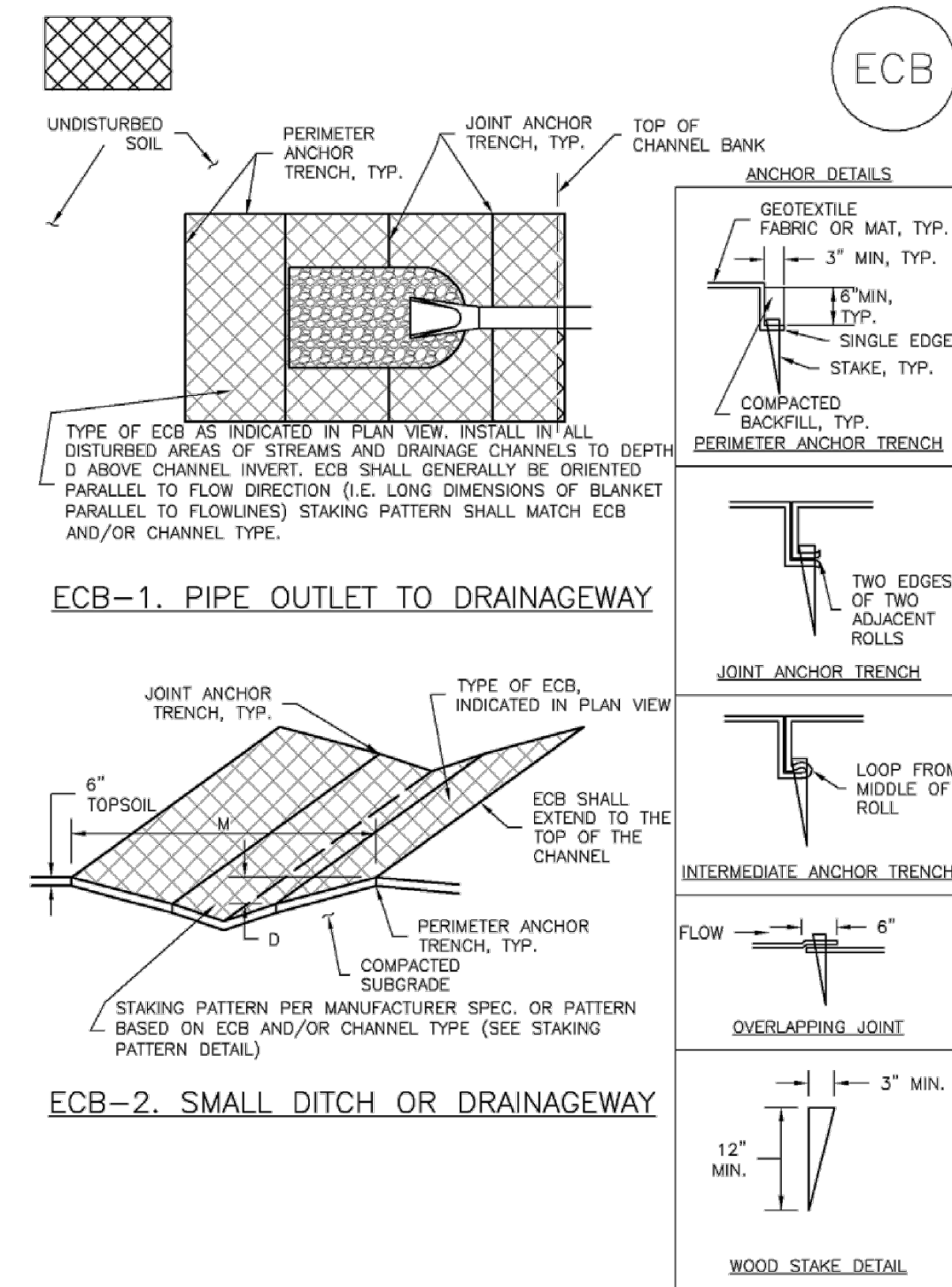

RECP-6 Urban Drainage and Flood Control District  
Urban Storm Drainage Criteria Manual Volume 3 November 2010

**EC-6 Rolled Erosion Control Products (RECP)**

**EROSION CONTROL BLANKET INSTALLATION NOTES**

- SEE PLAN VIEW FOR:
  - LOCATION OF ECB
  - TYPE OF ECB (STRAW, STRAW-COCONUT, COCONUT, OR EXCELSIOR)
  - AREA, A, IN SQUARE YARDS OF EACH TYPE OF ECB.
- 100% NATURAL AND BIODEGRADABLE MATERIALS ARE PREFERRED FOR RECPs, ALTHOUGH SOME JURISDICTIONS MAY ALLOW OTHER MATERIALS IN SOME APPLICATIONS.
- IN AREAS WHERE ECBs ARE SHOWN ON THE PLANS, THE PERMITTEE SHALL PLACE TOPSOIL AND PERFORM FINAL GRADING, SURFACE PREPARATION, AND SEEDING AND MULCHING. SUBGRADE SHALL BE SMOOTH AND MOIST PRIOR TO ECB INSTALLATION AND THE ECB SHALL BE IN FULL CONTACT WITH SUBGRADE. NO GAPS OR VOIDS SHALL EXIST UNDER THE BLANKET.
- PERIMETER ANCHOR TRENCH SHALL BE USED ALONG THE OUTSIDE PERIMETER OF ALL BLANKET AREAS.
- JOINT ANCHOR TRENCH SHALL BE USED TO JOIN ROLLS OF ECBs TOGETHER (LONGITUDINALLY AND TRANSVERSELY) FOR ALL ECBs EXCEPT STRAW WHICH MAY USE AN OVERLAPPING JOINT.
- INTERMEDIATE ANCHOR TRENCH SHALL BE USED AT SPACING OF ONE-HALF ROLL LENGTH FOR COCONUT AND EXCELSIOR ECBs.
- OVERLAPPING JOINT DETAIL SHALL BE USED TO JOIN ROLLS OF ECBs TOGETHER FOR ECBs ON SLOPES.
- MATERIAL SPECIFICATIONS OF ECBs SHALL CONFORM TO TABLE ECB-1.
- ANY AREAS OF SEEDING AND MULCHING DISTURBED IN THE PROCESS OF INSTALLING ECBs SHALL BE RESEEDED AND MULCHED.
- DETAILS ON DESIGN PLANS FOR MAJOR DRAINAGEWAY STABILIZATION WILL GOVERN IF DIFFERENT FROM THOSE SHOWN HERE.

TABLE ECB-1. ECB MATERIAL SPECIFICATIONS

TYPE	COCONUT CONTENT	STRAW CONTENT	EXCELSIOR CONTENT	RECOMMENDED NETTING**
STRAW*	-	100%	-	DOUBLE/NATURAL
STRAW-COCONUT	30% MIN	70% MAX	-	DOUBLE/NATURAL
COCONUT	100%	-	-	DOUBLE/NATURAL
EXCELSIOR	-	-	100%	DOUBLE/NATURAL

\*STRAW ECBs MAY ONLY BE USED INSIDE OF STORMS AND DRAINAGE CHANNELS.  
\*\*ALTERNATE NETTING MAY BE ACCEPTABLE IN SOME JURISDICTIONS.

RECP-8 Urban Drainage and Flood Control District  
Urban Storm Drainage Criteria Manual Volume 3 November 2010

**Rolled Erosion Control Products (RECP) EC-6**

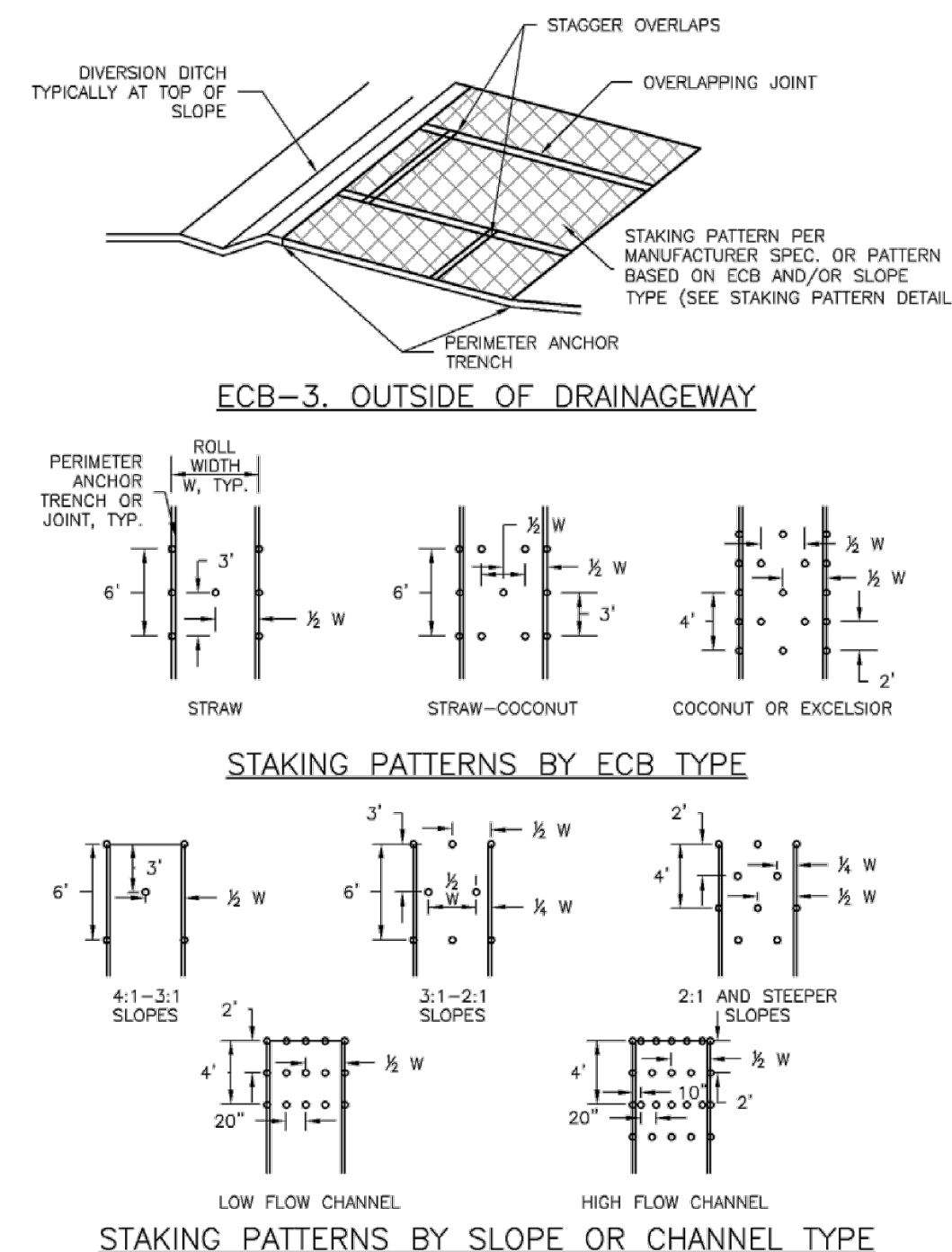

November 2010 Urban Drainage and Flood Control District  
Urban Storm Drainage Criteria Manual Volume 3 RECP-7

**Rolled Erosion Control Products (RECP) EC-6**

**EROSION CONTROL BLANKET MAINTENANCE NOTES**

- INSPECT BMPs EACH WORKDAY, AND MAINTAIN THEM IN EFFECTIVE OPERATING CONDITION. MAINTENANCE OF BMPs SHOULD BE PROACTIVE, NOT REACTIVE. INSPECT BMPs AS SOON AS POSSIBLE (AND ALWAYS WITHIN 24 HOURS) FOLLOWING A STORM THAT CAUSES SURFACE EROSION, AND PERFORM NECESSARY MAINTENANCE.
  - FREQUENT OBSERVATIONS AND MAINTENANCE ARE NECESSARY TO MAINTAIN BMPs IN EFFECTIVE OPERATING CONDITION. INSPECTIONS AND CORRECTIVE MEASURES SHOULD BE DOCUMENTED THOROUGHLY.
  - WHERE BMPs HAVE FAILED, REPAIR OR REPLACEMENT SHOULD BE INITIATED UPON DISCOVERY OF THE FAILURE.
  - ECBs SHALL BE LEFT IN PLACE TO EVENTUALLY BIODEGRADE, UNLESS REQUESTED TO BE REMOVED BY THE LOCAL JURISDICTION.
  - ANY ECB PULLED OUT, TORN, OR OTHERWISE DAMAGED SHALL BE REPAIRED OR REINSTALLED. ANY SUBGRADE AREAS BELOW THE GEOTEXTILE THAT HAVE ERODED TO CREATED A VOID UNDER THE BLANKET, OR THAT REMAIN DEVOID OF GRASS SHALL BE REPAIRED, RESEEDED AND MULCHED AND THE ECB REINSTALLED.
- NOTE: MANY JURISDICTIONS HAVE BMP DETAILS THAT VARY FROM UDFCD STANDARD DETAILS. CONSULT WITH LOCAL JURISDICTIONS AS TO WHICH DETAIL SHOULD BE USED WHEN DIFFERENCES ARE NOTED.
- (DETAILS ADAPTED FROM DOUGLAS COUNTY, COLORADO AND TOWN OF PARKER, COLORADO, NOT AVAILABLE IN AUTOCAD)

November 2010 Urban Drainage and Flood Control District  
Urban Storm Drainage Criteria Manual Volume 3 RECP-9

**NOTES:**

NO PHASING PLAN PROPOSED FOR THIS PROJECT. GRADING WITHIN THIS PROJECT WILL BE FULLY DEVELOPED FOLLOWING HOME BUILDING OPERATIONS. INITIAL TEMPORARY CONSTRUCTION CONTROL METHODS TO INCLUDE INLET PROTECTION AND SILT FENCING. INTERIM TEMPORARY CONSTRUCTION CONTROL METHODS TO INCLUDE VEHICLE TRACKING, ROADWAY STRAW BALE BARRIERS AND TEMPORARY SEDIMENT BASINS. FINAL METHODS TO INCLUDE PERMANENT STORMWATER QUALITY PONDS AND CONTINUAL MAINTENANCE OF INITIAL AND INTERIM METHODS AS WELL AS EROSION CONTROL BLANKETING AND FINAL RE-SEEDING ESTABLISHMENT THROUGHOUT HOME BUILDING AT ULTIMATE DEVELOPMENT.

THE AVERAGE SOIL CONDITION REFLECTS HYDROLOGIC GROUP A BLAKELAND LOAMY SAND AS DETERMINED BY THE "SOIL SURVEY OF EL PASO COUNTY AREA" PREPARED BY THE SOIL CONSERVATION SERVICE.

NO PORTION OF THIS SITE IS LOCATED WITHIN A FLOODPLAIN AS DETERMINED BY THE FLOOD INSURANCE RATE MAPS (F.I.R.M.) MAP NUMBER 08041C0752G AND 08041C0756G, EFFECTIVE DATE, DECEMBER 7, 2018.

STOCKPILE LOCATION, STORAGE OF MAINTENANCE EQUIPMENT AND TEMPORARY DISPOSAL AREAS (CONCRETE WASHOUT) ARE LOCATED OFF SITE FOR HOMEBUILDING. CONCRETE WASHOUT FOR DEVELOPMENT (CURB AND GUTTER) TO BE TEMPORARILY LOCATED BY CONTRACTOR AND UPDATED ON THIS PLAN. LOCATION OF STAGING AREAS, STORAGE FOR MAINTENANCE EQUIPMENT, TEMPORARY DISPOSAL AREAS AND SPILL PREVENTION AND RESPONSE PLAN PROCEDURES WILL BE ADDED TO THIS PLAN BY SWMP ADMINISTRATOR UPON COORDINATION WITH SELECTED CONTRACTOR AND SHALL BE WITHIN CONSTRUCTION SITE BOUNDARIES AS SHOWN.

EXISTING VEGETATION CONSISTS OF TALL NATIVE GRASSES AND WEEDS WITH SPORADIC CACTI AND YUCCAS THROUGH-OUT THE SITE. NEW DISTURBED AREAS TO BE RESEEDED AFTER WORK IS COMPLETED. FINAL VEGETATIVE COVER DENSITY IS TO BE 70% OF PRE-DISTURBED LEVELS.

EMERGENCY OVERFLOW SWALES FOR INLETS IN THE INTERIM UNTIL CURB AND ASPHALT IS INSTALLED WILL BE THE LOTS, FINAL WILL BE TO OVERTOP THE HIGH POINT IN ROADWAY TO THE NEXT AVAILABLE INLET OR THRU A TRACT TO THE PROPOSED SWQ FACILITIES.

STOCKPILE LOCATIONS FOR HOMEBUILDING TO BE ON EACH INDIVIDUAL LOT THAT IS BEING BUILT UPON.

LIMITS OF DISTURBANCE FOR THIS PLAN INCLUDE UTILITY INSTALLATION AND ROADWAY CONSTRUCTION WITHIN THE R.O.W. AND OVERLOT GRADING FOR DEVELOPMENT THEN INDIVIDUAL LOTS FOR HOMEBUILDING ONCE CONSTRUCTION OF THE HOME BEGINS.

LIMITS OF DISTURBANCE FOR THIS PLAN INCLUDE DETAILED GRADING FOR DEVELOPMENT AND UTILITY INSTALLATION AND ROADWAY CONSTRUCTION WITHIN THE R.O.W., AND OVERLOT GRADING FOR DEVELOPMENT THEN INDIVIDUAL LOTS FOR HOMEBUILDING ONCE CONSTRUCTION OF THE HOME BEGINS.

PROPOSED RETAINING WALLS (IF APPLICABLE) TO BE DESIGNED AND PERMITTED BY OTHERS.

NO STREAMS CROSS THIS PROJECT. NO OFFSITE GRADING PROPOSED WITH THIS PROJECT.

ALL DISTURBED AREAS ARE TO BE RE-SEEDDED OUTSIDE OF THE FILING NO. 3 AREA. RESEED ALL AREAS AS NEEDED TO PREVENT EROSION AND SEDIMENT RUNOFF ONTO CONSTRUCTION ACTIVITIES.

"SOIL, GEOLOGY, AND GEOLOGIC HAZARD STUDY MIDTOWN AT HANNAH RIDGE, FILING NO. 3 AKERS DRIVE AND CONSTITUTION AVENUE EL PASO COUNTY, COLORADO" PREPARED BY ENTECH ENGINEERING, INC. AVAILABLE AT THE EL PASO COUNTY PLANNING AND COMMUNITY DEVELOPMENT DEPARTMENT.

EGP-20-007

48 HOURS BEFORE YOU DIG,  
CALL UTILITY LOCATORS  
**811**  
UTILITY NOTIFICATION CENTER OF COLORADO  
IT'S THE LAW

THE LOCATIONS OF EXISTING UNDERGROUND UTILITIES ARE SHOWN IN AN APPROXIMATE WAY ONLY. THE CONTRACTOR SHALL DETERMINE THE EXACT LOCATION OF ALL EXISTING UTILITIES BEFORE COMMENCING WORK. THE CONTRACTOR SHALL BE FULLY RESPONSIBLE FOR ANY AND ALL DAMAGES WHICH MIGHT BE CAUSED BY HIS FAILURE TO EXACTLY LOCATE AND PRESERVE ANY AND ALL UNDERGROUND UTILITIES.

NO.	REVISION	DATE

REVIEW:

PREPARED UNDER MY SUPERVISION FOR AND ON BEHALF OF  
CLASSIC CONSULTING ENGINEERS & SURVEYORS, LLC

KYLE R. CAMPBELL #29754 DATE 12/13/2021

MIDTOWN COLLECTION AT HANNAH RIDGE  
FILING NO. 3  
OVERLOT GRADING AND EROSION CONTROL PLAN  
DETAILS

DESIGNED BY	KRC	SCALE	DATE	12/06/2021
DRAWN BY	KC	(H) 1" = N/A	SHEET	5 OF 5
CHECKED BY	(V)	1" = N/A	JOB NO.	1116.35

N:\111635\DRAWINGS\CONSTRUCTION\GRADING\05-111635-010-05.dwg, 12/13/2021 11:33:16 AM, 1:1

**QUALIFIED STORMWATER MANAGER  
CERTIFICATE**



Environmental Solutions  
ENVIRONMENTAL COMPLIANCE MADE SIMPLE

---

# CERTIFICATE OF COMPLETION

This certificate is awarded to

Adam Doyle

---

For the successful completion of

**Qualified Stormwater Manager Inspector Training (CMSCIT-150)**

PRESENTED THIS 28TH DAY OF JUNE, 2021

---

Jeff Hattori, Instructor, CISEC