

Preliminary & Final Drainage Report
for
The Sanctuary Filing 1
at
Meridian Ranch



MERIDIAN RANCH

A GOLF & RECREATIONAL COMMUNITY

EL PASO COUNTY, COLORADO

May 2022

Prepared For:

GTL DEVELOPMENT, INC.
P.O. Box 80036
San Diego, CA 92138

Prepared By:
Tech Contractors
11910 Tourmaline Dr., Ste 130
Falcon, CO 80831
719.495.7444

**PUDSP2204 &
SF2220**

PCD Project No. PUDSP22XX
SF22XX

CERTIFICATIONS

Design Engineer's Statement:

The attached drainage plan and report were prepared under my direction and supervision and are correct to the best of my knowledge and belief. Said drainage report has been prepared according to the criteria established by the County for drainage reports and said report is in conformity with the applicable master plan of the drainage basin. I accept responsibility for any liability caused by any negligent acts, errors or omissions on my part in preparing this report.

Thomas A. Kerby, P.E. #31429

Owner/Developer's Statement:

I, the owner/developer have read and will comply with all of the requirements specified in this drainage report and plan.

Raul Guzman, Vice President
GTL Development, Inc.
P.O. Box 80036
San Diego, CA 92138

Date

El Paso County:

Filed in accordance with the requirements of the Drainage Criteria Manual, Volumes 1 & 2, El Paso County Engineering Criteria Manual and Land Development Code as amended.

Jennifer Irvine, P.E.
County Engineer / ECM Administrator

Date

Please revise to Joshua Palmer, P.E.
Interim County Engineer/ECM Administrator

**The Sanctuary Filing 1 at Meridian Ranch
Preliminary/Final Drainage Report**

Table of Contents

EXECUTIVE SUMMARY	<i>i</i>
INTRODUCTION	<i>1</i>
Purpose	1
Scope	1
Background	1
EXISTING CONDITIONS	3
General Location	3
Land Use	3
Climate	3
Topography and Floodplains	3
Geology	3
Natural Hazards Analysis	6
DRAINAGE BASINS AND SUB-BASINS	6
DRAINAGE DESIGN CRITERIA	7
SCS Hydrograph Procedure	7
Full Spectrum Design	7
DRAINAGE CALCULATIONS	8
SCS General Overview	8
SCS Calculations	9
Historic Drainage - SCS Calculation Method	9
Future Drainage - SCS Calculation Method	12
Rational Calculations	13
Rational Narrative	13
DETENTION POND	17
Existing Pond G Detention Storage Criteria	17
Downstream Analysis	18
DRAINAGE FEES	20
CONCLUSION	20
EROSION CONTROL DESIGN	21
General Concept	21
Four Step Process	21
Detention Pond	22
Silt Fence	22
Erosion Bales	22
Miscellaneous	22
REFERENCES	23

Figures

Figure 1: Vicinity Map 2
Figure 2: FEMA Floodplain Map..... 4
Figure 3: Soils Map 5
Figure 4 - Meridian Ranch SCS Method – Historic Basin Map.....Appendix H
Figure 5 - Meridian Ranch SCS Method – Interim Basin MapAppendix H
Figure 6- Meridian Ranch SCS Method – Future Basin MapAppendix H
Figure 7 - Meridian Ranch Rational Method – Basin MapAppendix H

Tables

Table 1: SCS Runoff Curve Numbers 7
Table 2: Detention Pond Summary: 8
Table 3: Historic Drainage Basins – SCS..... 9
Table 4: Interim Drainage Basins-SCS 10
Table 5: Future Drainage Basins-SCS..... 12
Table 6: Pond G Summary Data..... 18
Table 7: Key Design Point Comparison – Interim SCS Model..... 19
Table 8: Key Design Point Comparison – Future SCS Model 19

To Appendices:

- Appendix A - HEC-HMS Data
- Appendix B – Rational Calculations
- Appendix C - Detention Pond Information
- Appendix D – Outlet Protection Design
- Appendix E – Street Flow
- Appendix F – East Grass Swale Analysis
- Appendix G – Soil Resource Report
- Appendix H – Drainage Maps

EXECUTIVE SUMMARY

The purpose of the following Preliminary/Final Drainage Report (PDR/FDR) is to present the changes to the drainage patterns as a result the Sanctuary Filing 1 at Meridian Ranch (Sanctuary). Runoff quantities and proposed facilities have been calculated using the current City of Colorado Springs/El Paso County Drainage Criteria Manual (DCM) (1994 version) and portions of the City of Colorado Springs Drainage Criteria Manual, Volume 1 (DCM-1) ((2014 version) as amended by the El Paso County Engineering Criteria Manual (ECM).

This report based on the current version of the Meridian Ranch Sketch Plan amendment as adopted by the El Paso County Board of Commissioners on March 13, 2018. Hydrologic calculations follow method outlined in Chapter 6 of the 2014 version of the City of Colorado Springs Drainage Criteria Manual (COSDCM) as adopted by the El Paso County Board of County Commissioners by Resolution 15-042. Chapter 6 addresses the hydrologic calculation methods and includes an updated hydrograph to be used with storm drainage runoff. The Board adopted by the same resolution, Section 3.2.1 of Chapter 13 of the COSDCM referencing Full Spectrum Detention; the concept “provides better control of the full range of runoff rates that pass through detention facilities than the convention multi-stage concept. This section of the COSDCM identifies the necessity to provide full spectrum detention but does not prescribe a methodology to reach such the detention requirements. This report includes hydrologic models from HEC-HMS for the historic, interim and future conditions for the 2-yr, 5-yr, 10-yr, 25-yr, 50-yr, and 100-yr design storm frequencies. The interim and the future conditions include the existing detention facilities sized and modeled such that *“frequent and infrequent inflows are released at rates approximating undeveloped conditions”*

The Sanctuary encompasses 74± acres and is located in Section 20, Township 12 South, Range 64 West of the 6th Principal Meridian. It is approximately 12 miles northeast of the city of Colorado Springs, 2.5 miles north of the unincorporated town of Falcon, and immediately north of the Woodmen Hills development.

the Sanctuary Filing 1 is located within Gieck Ranch Drainage Basin. The Gieck Ranch Basin has been studied, but has not received final approval from El Paso County. The developer has agreed to meet the requirements of the studied Gieck Ranch Basin but as yet to be approved Drainage Basin Study.

Based on the aforementioned design parameters the development of the project will not adversely affect downstream properties.

INTRODUCTION

Purpose

The purpose of the following Preliminary/Final Drainage Report (PDR/FDR) is to present proposed changes to the drainage patterns as a result of the development of the Sanctuary. The report outlines the proposed drainage mitigation based on calculated developed flows in excess of allowable exiting runoff discharge.

Scope

The scope of this report includes:

- Location and description of the proposed development stating the proposed land use, density, acreage and adjacent features to the site.
- Calculations for design peak flows from all off-site tributary drainage areas.
- Calculations for design peak flows within the proposed project area for all drainage areas.
- Discussion of major drainage facilities required as a result of the development.
- Discussion and analysis of existing and proposed facilities.

Runoff quantities and proposed facilities have been calculated using the current City of Colorado Springs/El Paso County Drainage Criteria Manual (DCM) (1994 version) and those portions of the City of Colorado Springs Drainage Criteria Manual, Volume 1 (DCM-1) ((2014 version) adopted by Resolution 15-042 of the El Paso County Board of County Commissioners as amended by the El Paso County Engineering Criteria Manual (ECM).

Background

On November 16, 2000 the El Paso County Board of County Commissioners approved the rezoning of the Meridian Ranch project (PUD-00-010) from A-35 to PUD with several conditions. Condition number seven stated in part that “drainage plans shall release and/or retain at approximately eighty percent (80%) of historic rates.” At the time of the initial approvals there were no drainage improvements downstream of the Meridian Ranch project and the existing natural channels were shallow and undefined.

The Sketch Plan Amendment (SKP-17-001) was processed and approved in 2018 by the El Paso County Board of County Commissioners by resolution 18-104 for Meridian Ranch. The resolution eliminated the required restriction of 80% of historic peak flow rates mentioned above. The detention pond proposed with this project will release at historic or less peak flow rates as per the current El Paso County stormwater requirements.

No development has occurred downstream of this project except for portions of the Falcon Regional Park providing ballparks and associated parking. The Meridian Ranch MDDP and this report indicate the Eastonville Road culvert crossing located downstream of this project does not provide enough capacity for the historic flow rates. It is anticipated that this culvert will be upgraded at the time of the Eastonville Road construction.

Current calculations show the future design discharge of the proposed Pond G to the Falcon Regional Park to be below historic flow rates at full buildout for the full spectrum of design storms.

Figure 1: Vicinity Map

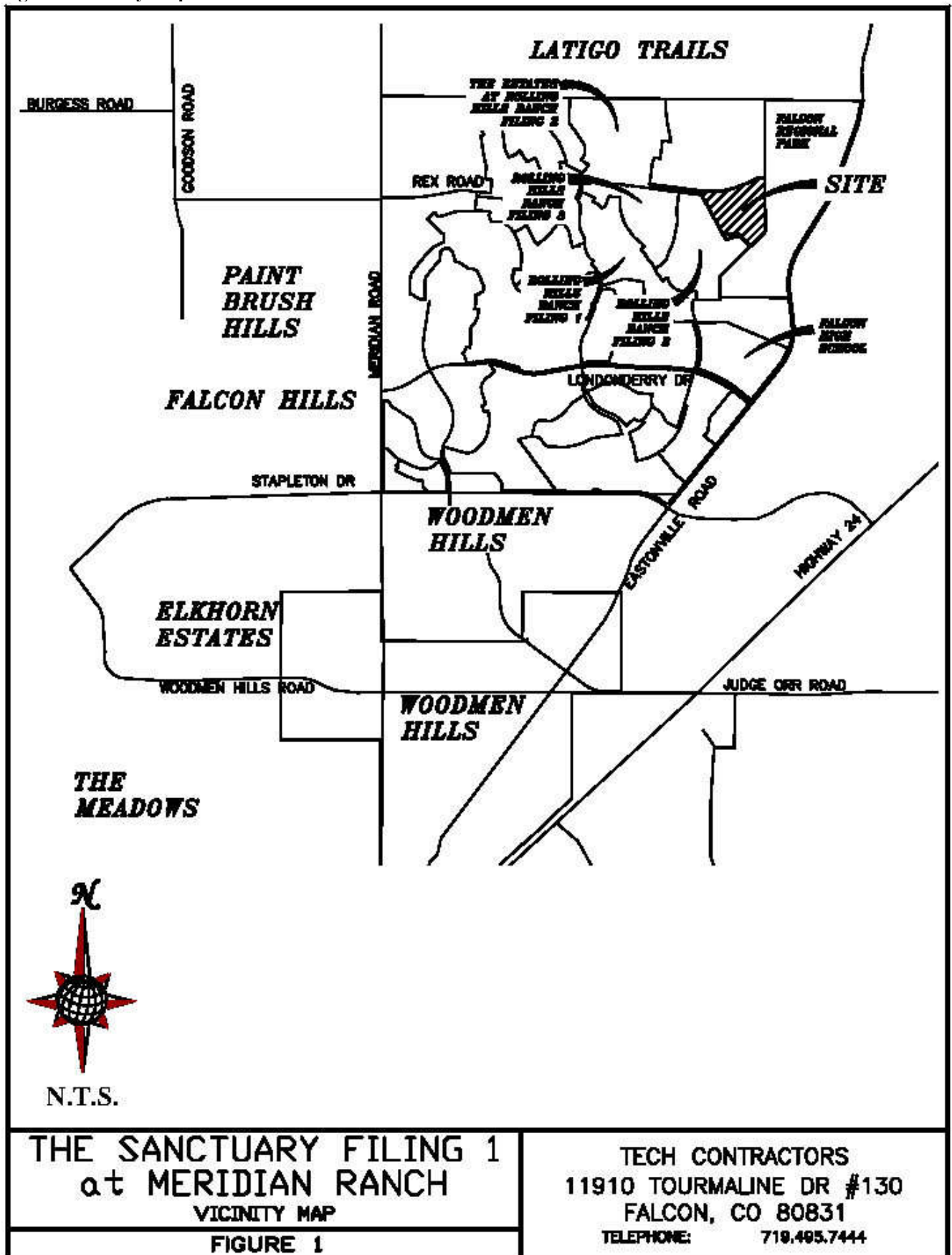

**THE SANCTUARY FILING 1
at MERIDIAN RANCH
VICINITY MAP**

FIGURE 1

**TECH CONTRACTORS
11910 TOURMALINE DR #130
FALCON, CO 80831
TELEPHONE: 719.495.7444**

EXISTING CONDITIONS

General Location

The Sanctuary project encompasses 74± acres and is located in Section 20, Township 12 South, Range 64 West of the 6th Principal Meridian. It is approximately 12 miles northeast of the city of Colorado Springs, 2.5 miles north of the unincorporated town of Falcon, and immediately north of the Woodmen Hills development.

Land Use

Historically, ranching dominated the area surrounding Meridian Ranch; however, currently urbanization has occurred in the general vicinity. Most notably, urbanization is occurring to the north with Latigo Trails, to the south in the Woodmen Hills Subdivision, to the east in Four Way Ranch, to the west in the Falcon Hills subdivision, and to the northwest in the Paint Brush Hills subdivision.

Climate

Mild summers and winter, light precipitation; high evaporation and moderately high wind velocities characterize the climate of the study area. The average annual monthly temperature is 48.4 F with an average monthly low of 30.3 F in the winter and an average monthly high of 68.1 F in the summer. Two years in ten will have maximum temperature higher than 98 F and a minimum temperature lower than -16 F. Precipitation averages 15.73" annually, with 80% of this occurring during the months of April through September. The average annual Class A pan evaporation is 45 inches. (Soil Survey of El Paso County Area, Colorado).

Topography and Floodplains

The topography of the site is typical of a high desert, short prairie grass with relatively flat slopes generally ranging from 2% to 4%. The project site drains generally from the northwest to southeast and is tributary to the Black Squirrel Creek.

The Flood Insurance Rate Maps (FIRM No. 08041C0552G dated 12/07/2018) indicates that the project is outside of any designated flood plain. Please see Figure 2: The Sanctuary Federal Emergency Management Agency (FEMA) Floodplain Map.

Geology

The National Resources Conservation Service (NRCS) soil survey records indicate that the service area is predominately covered by soils classified in the Columbine (53 ac.) and Stapleton series (21 ac.). These series are categorized in the Hydrological Soil Groups A & B.

The Stapleton (83) sandy loam is a deep, non-calcareous, well-drained soil formed in alluvium derived from arkosic bedrock on uplands. Permeability of this soil is rapid. Available water capacity is moderate, surface runoff is slow, and the hazard of erosion and soil blowing is moderate. The Stapleton series is categorized as a Hydrological Soil Group B.

This soil is used mainly for grazing livestock, for wildlife habitat and for home sites. The main limitation of this soil for urban development is a hazard of flooding in some areas.

Figure 2: FEMA Floodplain Map

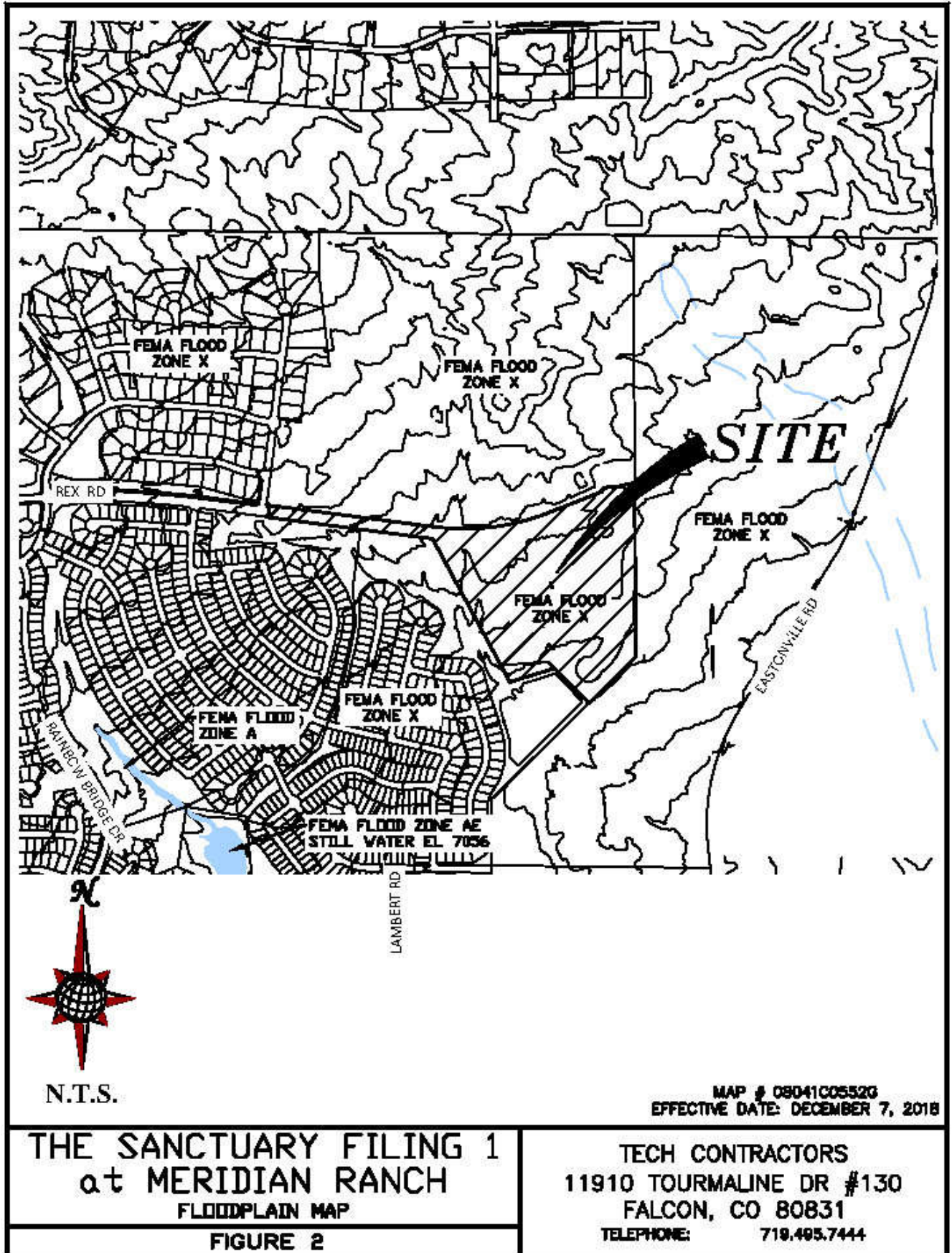

**THE SANCTUARY FILING 1
at MERIDIAN RANCH
FLOODPLAIN MAP**

FIGURE 2

**TECH CONTRACTORS
11910 TOURMALINE DR #130
FALCON, CO 80831
TELEPHONE: 719.495.7444**

Figure 3: Soils Map

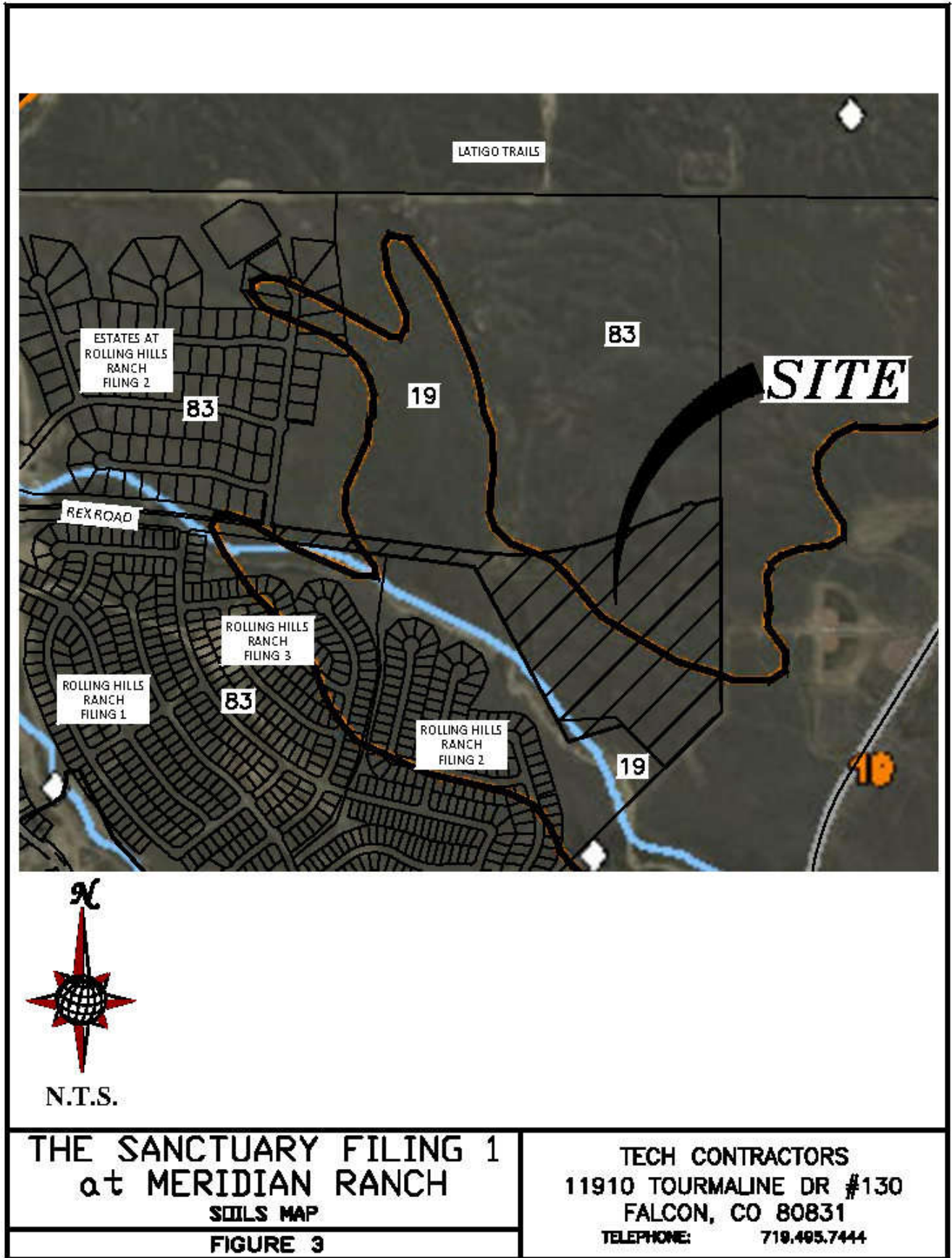

This soil is suited to habitat for open land and rangeland wildlife. The main limitation of this soil for urban development is frost-action potential.

Typically, these soils are well-drained, gravelly sandy loams that form on alluvial terraces and fans and exhibit high permeability and low available water capacity with depth to bedrock greater than 6 feet.

The Columbine (19) gravelly sandy loam is a deep, well-drained to excessively drained soil formed in coarse textured material on alluvial terraces, fans and flood plains. Permeability of this soil is very rapid. Available water capacity is low to moderate, surface runoff is slow, and the hazard of erosion is slight to moderate. The Columbine series is categorized as a Hydrological Soil Group A.

This soil is used mainly for grazing livestock, for wildlife habitat and for home sites. The main limitation of this soil for urban development is a hazard of flooding in some areas.

Note: (#) indicates Soil Conservation Survey soil classification number. See Figure 3 the Sanctuary Filing 1 – Soils Map.

Natural Hazards Analysis

Natural hazards analysis indicates that no unusual surface or subsurface hazards are located near the vicinity. However, because the soils are cohesionless, sloughing of steep banks during drilling and/or excavation could occur. By citing improvements in a manner that provides an opportunity to lay the banks of excavations back at a 1:1 slope during construction, the problems associated with sloughing soils can be minimized.

DRAINAGE BASINS AND SUB-BASINS

The site is near the top of the Gieck Ranch Drainage Basin and accepts flow from areas north of the extension of Rex Road within Meridian Ranch and portions of the Latigo development.

Three different scenarios were analyzed for the drainage conditions for the project.

The first scenario analyzes the historic conditions for Meridian Ranch. This condition has all of Meridian Ranch in the pre-development state; where the entirety of Meridian Ranch is modeled in its undeveloped, undisturbed condition, alternatively called the historic condition.

The second scenario is the interim conditions scenario and it consists of the current existing conditions for all areas whether developed or undeveloped/historic with the addition of the Sanctuary Filing 1 in the proposed developed condition. The current existing conditions assume all approved projects tributary to the Sanctuary Filing 1 are at full buildout. This condition was analyzed to ensure that the historic flow rates at the outlets of the existing Pond G (Design Point G12) located upstream of and adjacent to the Falcon Regional Park are maintained.

The final scenario analyzes the future build out conditions for the entirety of Meridian Ranch to ensure the storm drain and future detention facilities located at the discharge point downstream of this project are able to properly attenuate the full spectrum of developed peak flow rates to historic peak flow rates as the storm water exits the Meridian Ranch project onto the adjacent Falcon Regional Park.

DRAINAGE DESIGN CRITERIA

SCS Hydrograph Procedure

The US Army Corp of Engineers HEC-HMS computer program was used to model the Soil Conservation Service (SCS) Hydrograph procedure to determine final design parameters for the major drainage facilities within the project. Onsite basin areas were calculated using aerial topography of the site and approved final design data. Times of concentration were estimated using the SCS procedures described in the DCM. Based upon the hydrologic soil type, the natural conditions found in the basins and the runoff curve numbers (CN) chart from Table 6-10 of the City of Colorado Springs DCM for Antecedent Runoff Condition II (ARC II), the following CN values were used for the given conditions.

Table 1: SCS Runoff Curve Numbers

Condition	CN*		
Residential Lots (5 acre)	63	School	80
Residential Lots (2.5 acre)	66	Parks/Open Space	62
Residential Lots (1 acre)	68	Commercial	85
Residential Lots (1/2 acre)	70	Roadways	98
Residential Lots (1/3 acre)	72	Graded	67
Residential Lots (1/4 acre)	75	Golf Course	62
Residential Lots (1/5 acre)	78	Latigo Undeveloped	65
Residential Lots (1/6 acre)	80	Undeveloped	61

*Curve Numbers were interpolated and based on amount of impervious area per lot. The 24 hour storm precipitation values were selected from the NOAA Atlas 14, Volume 8, Version 2 for the Meridian Ranch location (Latitude 38.9783°, Longitude -104.5842°, Elevation 7054 ft). These numbers along with SCS information were used as input to the U.S. Army Corp of Engineers HEC-HMS computer model to determine design runoffs. See the table for all the design storm events in Appendix A. These numbers along with SCS information were used as input to the U.S. Army Corp of Engineers HEC-HMS computer model to determine design runoffs.

Full Spectrum Design

The City of Colorado Springs adopted a new Drainage Criteria Manual (DCM) in 2014 which incorporated the use of *Full Spectrum Design* for storm drainage analysis for projects located within the city limits. El Paso County adopted portions of the City’s 2014 DCM by resolution in January 2015; the County resolution adopted Chapter 6 (Hydrology) and Section 3.2.1 of Chapter 13 (Full Spectrum Detention) for projects outside of the City of Colorado Springs establishing a one year review period to analyze the impacts of the Full Spectrum Design on the storm drainage analysis of projects. This report has incorporated the use of full spectrum in the analysis using the SCS Method to determine the size requirements for the detention pond during the interim and future conditions.

The idea behind full spectrum detention is to release the developed runoff flow rates that will approximate those of the pre-developed condition. The existing design of Pond G and the outlet control structure meets or exceeds the intent and spirit of the concept.

Table 2: Detention Pond Summary:

POND G				
	PEAK INFLOW	PEAK OUTFLOW	PEAK STORAGE	PEAK ELEVATION
	CFS	CFS	AC-FT	FT
INTERIM CONDITIONS				
2-YEAR STORM	33	5.0	5.0	7026.7
5-YEAR STORM	85	19	8.7	7027.5
10-YEAR STORM	156	50	11.3	7027.9
50-YEAR STORM	452	307	20.4	7029.5
100-YEAR STORM	667	466	25.7	7030.3
FUTURE CONDITIONS				
2-YEAR STORM	47	5.3	5.7	7026.8
5-YEAR STORM	108	21	8.9	7027.5
10-YEAR STORM	187	52	11.5	7028.0
50-YEAR STORM	477	293	20.0	7029.4
100-YEAR STORM	663	450	24.8	7030.1

DRAINAGE CALCULATIONS

SCS General Overview

The project is located within the Gieck Ranch Drainage Basin; storm water runoff will be conveyed across the site overland and within proposed storm drain networks to the existing Pond G detention facility.

The Pond G detention facility has been adequately sized such that the developed flows detained and released will approximate the historic flow rates for the various design storm events for both the interim condition and in the future as the storm flow exits Meridian Ranch onto the Falcon Regional Park.

Figure 4: Meridian Ranch SCS Calculations – Historic Conditions Map, Figure 5: Meridian Ranch SCS Calculations – Interim Conditions Map and Figure 6: Meridian Ranch SCS Calculations – Future Conditions Map depict the historic, interim and future general drainage patterns for the Sanctuary Filing 1.

The purpose of this report is to show that the development of the Sanctuary Filing 1 will not adversely impact the existing drainage facilities adjacent to and downstream of the developed area and the existing Pond G is properly sized for the anticipated future development.

SCS Calculations

Historic Drainage - SCS Calculation Method

Following is a tabulation of the surface drainage characteristics under Existing Conditions using the SCS calculation method. Please refer to Figure 4 - Meridian Ranch SCS Calculations - Historic Basin Map.

Table 3: Historic Drainage Basins – SCS

HISTORIC SCS (Full Spectrum)						
HYDROLOGIC ELEMENT	DRAINAGE AREA (SQ. MI.)	PEAK DISCHARGE Q100 (CFS)	PEAK DISCHARGE Q50 (CFS)	PEAK DISCHARGE Q10 (CFS)	PEAK DISCHARGE Q5 (CFS)	PEAK DISCHARGE Q2 (CFS)
OS06	0.1313	80	52	12	3.8	0.52
OS06-G02	0.1313	77	52	11	3.7	0.52
OS05	0.0578	39	26	5.6	1.8	0.23
OS05-G01	0.0578	38	25	5.5	1.7	0.23
HG01	0.0547	32	21	4.7	1.5	0.22
G01	0.1125	70	46	10	3.2	0.45
G01-G02	0.1125	68	46	9.9	3.2	0.45
HG02	0.0906	45	30	6.7	2.3	0.36
G02	0.3344	191	127	27	9.0	1.32
G02-G03	0.3344	190	125	27	9.0	1.32
HG03	0.1828	77	51	12	4.3	0.72
OS07	0.0328	25	17	4.5	1.7	0.26
OS07-G03	0.0328	24	17	4.3	1.7	0.26
G03	0.5500	291	192	42	15	2.25
G03-G04	0.5500	281	189	42	14	2.25
OS09	0.1547	91	63	19	8.3	1.89
OS09-G04	0.1547	90	62	18	8.3	1.88
HG04	0.0891	40	26	5.9	2.1	0.34
HG05	0.1125	49	32	7.4	2.6	0.43
OS08	0.0406	35	25	7.7	3.4	0.72
OS08-G04	0.0406	34	24	7.4	3.4	0.72
G04	0.9469	493	332	76	28	4.71
G04-G05	0.9469	488	318	76	27	4.69
HG06A	0.1375	49	32	7.6	2.9	0.51
G05	1.0844	536	350	84	30	5.18
G05-G06	1.0844	520	348	83	30	5.16
HG06B	0.1031	33	22	5.3	2.0	0.37
G06	1.1875	551	369	88	32	5.52

Interim Drainage - SCS Calculation Method

Following is a tabulation of the surface drainage characteristics for the interim conditions using the SCS calculation method. Please refer to Figure 5 - Meridian Ranch SCS Calculations – Interim Basins Map

Table 4: Interim Drainage Basins-SCS

INTERIM SCS (Full Spectrum)						
	DRAINAGE AREA (SQ. MI.)	PEAK DISCHARGE Q100 (CFS)	PEAK DISCHARGE Q50 (CFS)	PEAK DISCHARGE Q10 (CFS)	PEAK DISCHARGE Q5 (CFS)	PEAK DISCHARGE Q2 (CFS)
OS06	0.1313	80	52	12	3.8	0.5
G1a	0.1313	80	52	12	3.8	0.5
G1a-G2	0.1313	79	52	11	3.7	0.5
OS05	0.0578	39	26	5.6	1.8	0.2
OS05-G1	0.0578	39	25	5.5	1.7	0.2
FG01	0.0538	31	22	7.0	3.4	0.9
FG01-G1	0.0538	31	22	7.0	3.4	0.9
G1	0.1116	61	41	11	4.9	1.1
G1-G2	0.1116	61	41	11	4.8	1.1
FG02	0.0391	32	22	6.4	2.7	0.5
G2	0.2820	167	112	27	10	1.9
G2-G3	0.2820	163	108	27	10	1.9
FG03	0.0203	24	17	5.9	3.0	0.8
FG04	0.0172	22	16	5.8	3.1	0.9
G3	0.3195	185	123	31	12	2.4
FG06	0.0675	56	40	12	5.8	1.3
FG05	0.0580	45	33	12	6.7	2.4
OS07ab	0.0170	12	7.9	1.8	0.5	0.1
OS07ab-POND F	0.0170	12	7.6	1.7	0.5	0.1
POND F IN	0.4620	293	200	54	23	5.1
POND F	0.4620	178	121	16	8.0	2.1
POND F-G7	0.4620	177	120	16	8.0	2.1
OS07c	0.0158	13	8.6	1.8	0.6	0.1
OS07c-G4	0.0158	13	8.2	1.8	0.5	0.1
FG21a	0.0095	5.9	4.0	1.0	0.4	0.1
G4	0.0253	19	12	2.8	0.9	0.1
G4-G7	0.0253	17	12	2.7	0.9	0.1
FG21b	0.0150	21	16	6.5	3.9	1.7
G7	0.5023	189	127	18	8.7	2.3
G7-G8	0.5023	188	127	18	8.7	2.3
FG22	0.1400	124	90	32	17	5.3
OS08a	0.0469	29	19	4.4	1.5	0.2
OS08-G8	0.0469	29	19	4.3	1.5	0.2
FG23a	0.0216	21	15	5.2	2.7	0.8
OS07d	0.0036	2.6	1.7	0.4	0.1	0.0
OS07d-G8	0.0036	2.6	1.7	0.4	0.1	0.0
G8	0.7144	283	179	48	25	7.6
G8-G10	0.7144	282	179	47	24	7.6
OS08b	0.1167	72	49	14	6.1	1.3
OS08b-G9a	0.1167	71	49	14	6.0	1.2
FG24b	0.0589	41	30	10	4.9	1.4
FG24a	0.0359	23	15	4.0	1.6	0.3
OS09a	0.0279	17	11	2.8	1.0	0.2
OS09a-G9a	0.0279	17	11	2.7	1.0	0.2
G9a	0.2394	148	100	28	12	2.6

INTERIM SCS (Full Spectrum)						
	DRAINAGE AREA (SQ. MI.)	PEAK DISCHARGE Q100 (CFS)	PEAK DISCHARGE Q50 (CFS)	PEAK DISCHARGE Q10 (CFS)	PEAK DISCHARGE Q5 (CFS)	PEAK DISCHARGE Q2 (CFS)
G9a-G9b	0.2394	145	100	28	12	2.6
FG24c	0.0291	26	18	5.8	2.9	0.8
FG24d	0.0262	30	23	10	5.7	2.6
G9b	0.2947	185	126	36	16	4.0
REX RD WQCV	0.2947	173	126	35	16	3.8
G9b-G10	0.2947	172	125	35	16	3.8
FG23b	0.0235	18	12	3.0	1.1	0.2
G10	1.0326	459	286	80	39	11
G10-G11	1.0326	458	285	79	38	11
FG23c	0.0109	11	7.7	2.3	1.0	0.2
G11	1.0435	461	287	80	39	11
FG25	0.1084	111	84	36	22	9.9
FG28	0.0184	15	10	3.0	1.2	0.2
POND G IN-W	1.1703	544	357	112	56	17
FG27	0.0679	81	64	34	24	14
FG26	0.0570	45	32	11	5.1	1.3
G13	0.0570	45	32	11	5.1	1.3
G13-POND G	0.0570	45	32	10	5.1	1.3
POND G IN-E	0.1249	123	95	44	29	15
POND G	1.2952	466	307	50	19	5.0
G12	1.2952	466	307	50	19	5.0
G12-G06	1.2952	465	307	49	19	5.0
FG29	0.0983	60	39	8.9	2.9	0.4
FG32	0.0402	21	14	3.1	1.0	0.2
FG32-G06	0.0402	21	14	3.1	1.0	0.2
G06	1.4337	491	323	52	20	5.3

Future Drainage - SCS Calculation Method

Following is a tabulation of the surface drainage characteristics for the future conditions using the SCS calculation method. Please refer to Figure 6 - Meridian Ranch SCS Calculations – Future Basins Map

Table 5: Future Drainage Basins-SCS

FUTURE SCS (Full Spectrum)						
	DRAINAGE AREA (SQ. MI.)	PEAK DISCHARGE Q100 (CFS)	PEAK DISCHARGE Q50 (CFS)	PEAK DISCHARGE Q10 (CFS)	PEAK DISCHARGE Q5 (CFS)	PEAK DISCHARGE Q2 (CFS)
OS06	0.1313	80	52	12	3.8	0.5
G1a	0.1313	80	52	12	3.8	0.5
G1a-G2	0.1313	79	52	11	3.7	0.5
OS05	0.0578	39	26	5.6	1.8	0.2
OS05-G1	0.0578	39	25	5.5	1.7	0.2
FG01	0.0538	31	22	7.0	3.4	0.9
FG01-G1	0.0538	31	22	7.0	3.4	0.9
G1	0.1116	61	41	11	4.9	1.1
G1-G2	0.1116	61	41	11	4.8	1.1
FG02	0.0391	32	22	6.4	2.7	0.5
G2	0.2820	167	112	27	10	1.9
G2-G3	0.2820	163	108	27	10	1.9
FG03	0.0203	24	17	5.9	3.0	0.8
FG04	0.0172	22	16	5.8	3.1	0.9
G3	0.3195	185	123	31	12	2.4
FG06	0.0675	56	40	12	5.8	1.3
FG05	0.0580	45	33	12	6.7	2.4
OS07ab	0.0170	12	7.9	1.8	0.5	0.07
OS07ab-POND F	0.0170	12	7.6	1.7	0.5	0.07
POND F IN	0.4620	293	200	54	23	5.1
POND F	0.4620	178	121	16	8.0	2.1
POND F-G7	0.4620	177	120	16	8.0	2.1
OS07c	0.0296	19	12	2.7	0.9	0.12
OS07c-G4	0.0296	19	12	2.6	0.9	0.12
FG21a	0.0095	5.9	4.0	1.0	0.4	0.06
G4	0.0391	25	16	3.6	1.2	0.2
G4-G7	0.0391	24	16	3.5	1.2	0.2
FG21b	0.0150	21	16	6.5	3.9	1.7
G7	0.5161	194	131	18	8.9	2.3
G7-G8	0.5161	194	131	18	8.9	2.3
FG22	0.1354	121	88	32	17	5.4
OS08a	0.0251	16	11	2.3	0.7	0.10
OS08-G8	0.0251	16	10	2.3	0.7	0.10
FG23a	0.0216	21	15	5.2	2.7	0.8
OS07d	0.0034	2.5	1.6	0.4	0.11	0.01
OS07d-G8	0.0034	2.4	1.6	0.3	0.11	0.01
G8	0.7016	279	178	46	24	7.7
G8-G10	0.7016	278	177	45	24	7.6
FG24b	0.0589	76	57	24	15	6.5
FG24a	0.0348	24	16	4.5	2.0	0.4
OS08b	0.0165	9.5	6.3	1.4	0.5	0.07
OS08b-G9a	0.0165	9.4	6.0	1.4	0.5	0.07
OS09a	0.0093	5.3	3.5	0.8	0.3	0.04
OS09a-G9a	0.0093	5.2	3.4	0.7	0.3	0.04
G9a	0.1195	97	71	28	16	6.7

FUTURE SCS (Full Spectrum)						
	DRAINAGE AREA (SQ. MI.)	PEAK DISCHARGE Q100 (CFS)	PEAK DISCHARGE Q50 (CFS)	PEAK DISCHARGE Q10 (CFS)	PEAK DISCHARGE Q5 (CFS)	PEAK DISCHARGE Q2 (CFS)
G9a-G9b	0.1195	96	70	27	16	6.6
FG24c	0.0291	40	30	13	8.4	4.0
FG24d	0.0262	39	30	14	8.7	4.4
G9b	0.1748	170	127	53	32	14
REX RD WQCV	0.1748	158	125	51	31	14
G9b-G10	0.1748	158	123	50	31	13
FG23b	0.0236	17	11	2.7	0.9	0.13
G10	0.9000	390	263	90	46	15
G10-G11	0.9000	389	254	85	44	15
FG23c	0.0109	11	7.6	2.2	1.0	0.2
G11	0.9109	393	258	86	44	15
FG25	0.1084	111	84	36	22	9.9
FG28	0.0184	15	10	3.0	1.2	0.2
POND G IN-W	1.0377	503	350	122	63	22
FG27	0.0679	98	79	42	30	18
FG26	0.0570	65	50	24	16	8.2
G13	0.0570	65	50	24	16	8.2
G13-POND G	0.0570	64	50	24	16	8.1
POND G IN-E	0.1249	160	127	64	44	25
POND G	1.1626	450	293	52	21	5.3
G12	1.1626	450	293	52	21	5.3
G12-G06	1.1626	449	293	52	21	5.3
FG29	0.0983	60	39	8.9	2.9	0.4
FG32	0.0402	51	40	20	14	7.5
FG32-G06	0.0402	50	40	19	13	7.4
G06	1.3011	491	317	57	22	7.5

Rational Calculations

The Rational Hydrologic Calculation Method was used to estimate the total runoff from the 5-year and the 100-year design storm and thus establish the storm drainage system design. Using the rational calculation methodology outlined in the Hydrology Section (Ch 6) of the COSDCM coupled with the El Paso County EPCDCM an effective storm drainage design for the Sanctuary Filing 1 has been designed. The storm drainage facilities have been designed such that the minor storm will be captured by the inlets and conveyed by the storm drain pipes such that the street flow does not overtop the curbs. The storm drainage facility has been designed such that the major storm will be captured by the inlets and conveyed by the storm drain pipes such that the street flow does not exceed the right-of-way widths for residential streets and the hydraulic grade line will be less than one foot below the surface.

The site is located within the Gieck Ranch Drainage Basin. The storm drain runoff will be collected by a series of inlets and storm drain pipe then conveyed through the project and discharge directly into the existing Pond G that is properly sized to safely convey the storm water flows away from the project without damaging adjacent property.

Rational Narrative

The following is a detailed narrative of the storm drainage system located in the Sanctuary Filing 1. These storm drainage systems meet the requirements of as found in the El Paso

County Engineering Criteria Manual I.7.1.C.5. (ECM) for storm water quality and discharge into Waters of the State. The discharge point is located at the existing Pond G, a Regional Detention Facility with WQCV incorporated into the design and construction. Some rear yard drainage will sheet flow off the properties into a proposed grass lined swale that will discharge directly to Pond G.

Offsite Areas

- Basin OS01 (27 acres, $Q_5 = 29$ CFS, $Q_{100} = 60$ CFS) contains off-site area north of Rex Road within the future Rolling Hills Ranch North subdivision entering the project via a proposed 36" RCP at Design Point 1. The surface runoff will be collected by a temporary inlet during the interim phase. In future phases the stormwater runoff will be collected and conveyed to Rex Road via a storm drain network. The stormwater is directed southerly manhole J01 north of Rex Road.
- Basin OS02 (3.0 acres, $Q_5 = 3.6$ CFS, $Q_{100} = 19$ CFS) contains off-site area north of Rex Road and west of Shelter Creek Dr. within the future Rolling Hills Ranch North subdivision entering the project via a proposed 42" RCP across Rex Rd. The surface runoff will sheet flow off of the future lots and be directed street, where the flow will continue downstream to a proposed 15' Type R sump inlet located at I01. All of the flow ($Q_5 = 3.6$ CFS, $Q_{100} = 19$ CFS) is captured and conveyed downstream via an 18" RCP to outlet at Storm Manhole J01.
- Basin OS03 (6.6 acres, $Q_5 = 7.4$ CFS, $Q_{100} = 19$ CFS) contains off-site area north of Rex Road and east of Shelter Creek Dr. within the future Rolling Hills Ranch North subdivision entering the project via a proposed 42" RCP across Rex Rd. The surface runoff will sheet flow off of the future lots and be directed street, where the flow will continue downstream to a proposed 15' Type R sump inlet located at I02. All of the flow ($Q_5 = 7.4$ CFS, $Q_{100} = 19$ CFS) is captured and conveyed downstream via an 18" RCP to outlet at Storm Manhole J01.
- The total pipe flow at Storm Manhole J01 from Basins OS01, OS02, & OS03 is $Q_5 = 38$ CFS, $Q_{100} = 93$ CFS and is conveyed via a 42" RCP to Storm Manhole J02.
- Basin A01 (5.3 acres, $Q_5 = 6.9$ CFS, $Q_{100} = 17$ CFS) contains rear portions of the lots north of Rex Road within the Rolling Hills Ranch North subdivision and runoff from Rex Road entering the project on the north side via the curb and gutter. The surface runoff will sheet flow off the residential lots onto Rex Road and be directed to the street, where the flow will be directed downstream to a proposed 15' Type R flow-by inlet located at I03. Most of the flow is captured ($Q_5 = 4.6$ CFS, $Q_{100} = 8.8$ CFS) with the remaining flow ($Q_5 = 2.3$ CFS, $Q_{100} = 7.9$ CFS) continuing downstream to Inlet I04.
- The total pipe flow at Storm Manhole J02 is $Q_5 = 42$ CFS, $Q_{100} = 99$ CFS and is conveyed via a 42" RCP to Storm Manhole J03.

- Basin A02 (4.3 acres, $Q_5 = 6.5$ CFS, $Q_{100} = 14$ CFS) contains lots along proposed Arriba Dr, the surface runoff will sheet flow off the lots where the flow will be directed downstream to a proposed 20' Type R flow-by inlet located at I04 and combined with flow-by from I03 ($Q_5 = 8.6$ CFS, $Q_{100} = 22$ CFS). Most of the flow ($Q_5 = 6.2$ CFS, $Q_{100} = 13$ CFS) is captured and conveyed downstream via an 18" RCP to Storm Manhole J03. The remaining flow ($Q_5 = 2.5$ CFS, $Q_{100} = 8.4$ CFS) continuing downstream to Inlet I05.
- The total pipe flow at Storm Manhole J03 is $Q_5 = 47$ CFS, $Q_{100} = 110$ CFS and is conveyed via a 48" RCP to Storm Manhole J04.
- Basin A03 (5.4 acres, $Q_5 = 8.4$ CFS, $Q_{100} = 18$ CFS) contains lots along proposed Nederland Dr, the surface runoff will sheet flow off the lots where the flow will be directed downstream to a proposed 20' Type R flow-by inlet located at I05 and combined with flow-by from I04 ($Q_5 = 9.8$ CFS, $Q_{100} = 24$ CFS). Most of the flow ($Q_5 = 7.7$ CFS, $Q_{100} = 16$ CFS) is captured and conveyed downstream via an 18" RCP to Storm Manhole J04. The remaining flow ($Q_5 = 2.1$ CFS, $Q_{100} = 7.9$ CFS) continuing downstream to Inlet I06.
- The total pipe flow at Storm Manhole J04 is $Q_5 = 53$ CFS, $Q_{100} = 124$ CFS and is conveyed via a 48" RCP to Storm Manhole J05.
- Basin A04 (4.7 acres, $Q_5 = 7.3$ CFS, $Q_{100} = 16$ CFS) contains lots along proposed Estes Ridge Dr and Rico Ridge Dr, the surface runoff will sheet flow off the lots where the flow will be directed downstream to a proposed 20' Type R flow-by inlet located at I06 and combined with flow-by from I05 ($Q_5 = 8.0$ CFS, $Q_{100} = 21$ CFS). Most of the flow ($Q_5 = 6.5$ CFS, $Q_{100} = 14$ CFS) is captured and conveyed downstream via an 18" RCP to Storm Manhole J05. The remaining flow ($Q_5 = 1.5$ CFS, $Q_{100} = 6.4$ CFS) continuing downstream to Inlet I10.
- The total pipe flow at Storm Manhole J05 is $Q_5 = 59$ CFS, $Q_{100} = 136$ CFS and is conveyed via a 54" RCP to Storm Manhole J06 and J07.
- Basin A05 (2.5 acres, $Q_5 = 4.4$ CFS, $Q_{100} = 9.1$ CFS) contains lots fronting along the east side of Shelter Creek Dr. The surface runoff will sheet flow off the residential lots and be directed to the street, where the flow will be directed downstream to a proposed 15' Type R flow-by inlet located at I07. Most of the flow ($Q_5 = 3.7$ CFS, $Q_{100} = 6.7$ CFS) is captured and conveyed downstream via an 18" RCP to Storm Manhole J07. The remaining flow ($Q_5 = 0.7$ CFS, $Q_{100} = 2.3$ CFS) continuing downstream to Inlet I11.
- The total pipe flow at Storm Manhole J07 is $Q_5 = 61$ CFS, $Q_{100} = 140$ CFS and is conveyed via a 54" RCP to Storm Manhole J11.
- Basin A06 (4.5 acres, $Q_5 = 7.8$ CFS, $Q_{100} = 17$ CFS) contains lots along Arriba Dr, Nederland Dr, and Estes Ridge Dr, the surface runoff will sheet flow off of the

residential lots and be directed to the street, where the flow will be directed downstream to a proposed 20' Type R flow-by inlet located at I08. Most of the flow ($Q_5 = 5.7$ CFS, $Q_{100} = 11$ CFS) is captured and conveyed downstream via an 18" RCP to Storm Manhole J08. The remaining flow ($Q_5 = 2.1$ CFS, $Q_{100} = 6.2$ CFS) continuing downstream to Inlet I09.

- The total pipe flow at Storm Manhole J08 is $Q_5 = 5.7$ CFS, $Q_{100} = 11$ CFS and is conveyed via an 18" RCP to Storm Manhole J09.
- Basin A07 (3.6 acres, $Q_5 = 5.7$ CFS, $Q_{100} = 13$ CFS) contains lots along proposed Rico Ridge Dr, the surface runoff will sheet flow off the lots where the flow will be directed downstream to a proposed 15' Type R flow-by inlet located at I09 and combined with flow-by from I08 ($Q_5 = 7.7$ CFS, $Q_{100} = 18$ CFS). Most of the flow ($Q_5 = 5.4$ CFS, $Q_{100} = 11$ CFS) is captured and conveyed downstream via an 18" RCP to Storm Manhole J09. The remaining flow ($Q_5 = 2.3$ CFS, $Q_{100} = 6.2$ CFS) continuing downstream to Inlet I10.
- The total pipe flow at Storm Manhole J09 is $Q_5 = 11$ CFS, $Q_{100} = 23$ CFS and is conveyed via a 24" RCP to Storm Manholes J10 and J11.
- Basin A08 (3.3 acres, $Q_5 = 5.3$ CFS, $Q_{100} = 14$ CFS) contains lots along the north side of proposed Manzanola Dr, the surface runoff will sheet flow off the lots where the flow will be directed downstream to a proposed 10' Type R sump inlet located at I10 and combined with flow-by from I05 and I09 ($Q_5 = 7.4$ CFS, $Q_{100} = 21$ CFS). All of the 5-year flow ($Q_5 = 7.4$ CFS) and most of the 100-year flow ($Q_{100} = 14$ CFS) is captured and conveyed downstream via an 18" RCP to Storm Manhole J11. The remaining flow ($Q_{100} = 7.0$ CFS) crosses the street to Inlet I11.
- The total pipe flow at Storm Manhole J11 from J07, J10, & I10 is $Q_5 = 79$ CFS, $Q_{100} = 174$ CFS and is conveyed via a 54" RCP to Inlet I11.
- Basin A09 (5.3 acres, $Q_5 = 7.9$ CFS, $Q_{100} = 18$ CFS) contains lots along the west side of Retreat Peak Dr, the south side of Manzanola Dr and Cuchara Way. The surface runoff will sheet flow off the residential lots and be directed to the street, where the flow will be directed downstream to a proposed 20' Type R sump inlet located at I11. All the stormwater flow is captured by this inlet.
- The total pipe flow at I11 is $Q_5 = 86$ CFS, $Q_{100} = 197$ CFS and is conveyed via a 54" RCP to OS3 at existing Pond G.
- Basin A10 (2.0 acres, $Q_5 = 2.5$ CFS, $Q_{100} = 5.8$ CFS) contains the rear portions of lots along the east side of Shelter Creek Dr. The surface runoff will sheet flow off the residential lots and be directed a swale flowing southerly toward DP3 near existing Pond G.

I08 is the last inlet on Shelter Creek that has flow by.

Please clarify if this includes flow by from inlet I07 and flow that crosses the street from inlet I10

- Basin A11 (1.8 acres, $Q_5= 2.1$ CFS, $Q_{100} = 5.2$ CFS) contains rear portions of lots along the south side of Manzanola Dr and the east side of Cuchara Way. The surface runoff will sheet flow off the residential lots and be directed to the swale mentioned above where the flow will be combined with the flow from A10 (total flow $Q_5= 3.9$ CFS, $Q_{100} = 9.0$ CFS) and directed downstream to the existing Pond G.
- Basin A12 (9.9 acres, $Q_5= 15$ CFS, $Q_{100} = 34$ CFS) contains the areas along Rex Road. The surface runoff will sheet flow off the surrounding areas and be directed downstream to a proposed 20' Type R sump inlet located at I12. All of the flow is captured by this inlet. The captured flow is conveyed downstream via a 24" RCP to the permanent water quality pond located on the north side of Rex Road at DP2.
- Basin OS04 (102 acres, $Q_5= 46$ CFS, $Q_{100} = 158$ CFS) contains off-site area north of Rex Road within the future Rolling Hills Ranch North subdivision and portions of Latigo Trail further north. The storm drainage is collected within a drainage swale and directed to a water quality pond located north of Rex Rd west of Retreat Peak Dr. The stormwater runoff will be collected and conveyed under Rex Road via a 54" RCP and discharged into the existing natural dry creek and conveyed to the existing Pond G.

DETENTION POND

Existing Pond G Detention Storage Criteria

Existing Detention Pond G was constructed with grading operations associated with the Rough Grading Plans for Rolling Hills Ranch at Meridian Ranch in anticipation of the future development of the Rolling Hills Ranch in accordance with the approved Sketch Plan. The pond is located within the Gieck Ranch Drainage Basin in the eastern portion of Rolling Hills Ranch adjacent to the Falcon Regional Park and is adjacent to and south of the Sanctuary Filing 1. The pond is owned and maintained by the Meridian Service Metropolitan District (MSMD) and a maintenance agreement between the MSMD and El Paso County was recorded with the Rolling Hills Ranch Filing 1 final plat.

Pond G and the existing Pond F work in series such that the peak flow rates from the Meridian Ranch development do not adversely affect the drainage patterns downstream of the Meridian Ranch project. A permanent concrete control structure handles full build out of the tributary area and reduces the developed flows to approximate the historic peak flow rates for the full spectrum of design storms.

The existing concrete control structure the outlet of Pond G will attenuate the peak developed flow rates to approximately historic peak rates for the full spectrum of design storms as per the requirements set forth in Resolution 15-042 adopted by the Board of County Commissioners, County of El Paso. The control structure consists of a water quality control feature, a rectangular slotted orifice located on the front and a grated top to reduce the developed peak flow rates. Table 6 provides summary data for the various design storms for the completed development for all areas tributary to Pond G including the Sanctuary Filing 1. Pond G was designed and constructed to receive and discharge the interim flows and the

anticipated future developed flows and therefore there are no proposed changes to the existing pond or outlet structure.

Table 6: Pond G Summary Data

POND G				
	PEAK INFLOW	PEAK OUTFLOW	PEAK STORAGE	PEAK ELEVATION
	CFS	CFS	AC-FT	FT
INTERIM CONDITIONS				
2-YEAR STORM	33	5.0	5.0	7026.7
5-YEAR STORM	85	19	8.7	7027.5
10-YEAR STORM	156	50	11.3	7027.9
50-YEAR STORM	452	307	20.4	7029.5
100-YEAR STORM	667	466	25.7	7030.3
FUTURE CONDITIONS				
2-YEAR STORM	47	5.3	5.7	7026.8
5-YEAR STORM	108	21	8.9	7027.5
10-YEAR STORM	187	52	11.5	7028.0
50-YEAR STORM	477	293	20.0	7029.4
100-YEAR STORM	663	450	24.8	7030.1

Downstream Analysis

The developed flow from this project will discharge at the westerly boundary of the Falcon Regional Park (G12), upstream of Eastonville Rd (DP G06). The discharge at this location during the interim period will be 491 CFS during the 100-yr storm event into an existing natural drainage course that traverses the regional park. The 100-year historical peak flow rate at the western boundary of the regional park is 536 CFS. The calculated 100-year interim flow rate will be 87% of the historic flow rate. See Table 7 for a complete comparative list of the peak flow rates for the key design points impacted by the development of the Sanctuary Filing 1.

Table 7: Key Design Point Comparison – Interim SCS Model

MERIDIAN RANCH DISCHARGE KEY DESIGN POINTS (INTERIM)						
		PEAK DISCHARGE Q ₁₀₀ (CFS)	PEAK DISCHARGE Q ₅₀ (CFS)	PEAK DISCHARGE Q ₁₀ (CFS)	PEAK DISCHARGE Q ₅ (CFS)	PEAK DISCHARGE Q ₂ (CFS)
G12 - DISCHARGE POINT AT REGIONAL PARK (G05 - HISTORIC)	Historic	536	350	84	30	5.2
	Interim	466	307	50	19	5.0
	% of Historic	87%	88%	59%	62%	96%
G06 - EASTONVILLE ROAD ¹	Historic	551	369	88	32	5.5
	Interim	491	323	52	20	5.3
	% of Historic	89%	87%	59%	62%	96%

¹ Flow rate at Eastonville Rd. listed for reference only

The outlet (DP G12) for Pond G located west of the Falcon Regional Park, upstream of Eastonville Rd (DP G06). At full buildout the discharge from Pond G will be 450 CFS during the 100-yr storm event into an existing natural drainage course that traverses the regional park. The 100-year historical peak flow rate at the western boundary of the regional park is 536 CFS. The calculated 100-year future developed flow rate will be 84% of the historic flow rate. The developed peak flow rate for the full spectrum of design storms are calculated to be below that of the corresponding historic peak flow rates. See Table 8 for a complete comparative list of the future developed peak flow rates for the key design points impacted by the development of Rolling Hills Ranch.

Table 8: Key Design Point Comparison – Future SCS Model

MERIDIAN RANCH DISCHARGE KEY DESIGN POINTS (FUTURE)						
		PEAK DISCHARGE Q ₁₀₀ (CFS)	PEAK DISCHARGE Q ₅₀ (CFS)	PEAK DISCHARGE Q ₁₀ (CFS)	PEAK DISCHARGE Q ₅ (CFS)	PEAK DISCHARGE Q ₂ (CFS)
G12 - POND G OUTLET REGIONAL PARK (G05 - HISTORIC)	Historic	536	350	84	30	5.2
	Future	450	293	52	21	5.3
	% of Historic	84%	84%	62%	68%	102%
G06 - EASTONVILLE ROAD ¹	Historic	551	369	88	32	5.5
	Future	491	317	57.1	22	7.5
	% of Historic	89%	86%	65%	71%	136%

¹ Flow rate at Eastonville Rd. listed for reference only

DRAINAGE FEES

The proposed development falls in the Gieck Ranch Drainage Basin. The entire development occupies 48.9 acres of residential development of which 26.3 acres are residential development and 14.7 acres are designated as right-of-way, the remainder is open space.

The following is the imperviousness calculation:

	<u>Acres</u>	<u>Assumed Imperviousness</u>	<u>Impervious Acres</u>
Open Space	7.80	3%	0.23
Right-of-way	14.73	90%	13.26
Residential Lots	26.33	65% (343 Lots)	17.11
Total	48.86		30.61=62.6% imperv

GIECK RANCH FEES:

Drainage Fees: There are no drainage fees for this basin.

Bridge Fees: There are no bridge fees for this basin.

CONCLUSION

The rational and SCS based hydrologic calculation methods were used to estimate the historic, interim, and future developed runoff values to determine the impact of this project on surrounding property. The resulting calculations were used to estimate the hydraulic impact on the existing and proposed facilities. Finally, the model storms were analyzed to simulate the impacts of storm events of various return periods on the existing detention pond and downstream facilities. Based on the aforementioned design parameters the development of the project will not adversely affect downstream properties.

EROSION CONTROL DESIGN

General Concept

Historically, erosion on this property has been held to a minimum by a variety of natural features and agricultural practices including:

- Substantial prairie grass growth
- Construction of drainage arresting berms
- Construction of multiple stock ponds along drainage courses

Existing temporary sediment ponds will also help to minimize erosion by reducing both the volume and velocity of the peak runoff.

During construction, best management practices (BMP) for erosion control will be employed based on El Paso county Criteria. BMP's will be utilized as deemed necessary by the contractor and/or engineer and are not limited to the measures shown on the construction drawing set. The contractor shall minimize the amount of area disturbed during all construction activities.

In general the following shall be applied in developing the sequence of major activities:

- Install down-slope and side-slope perimeter BMP's before the land disturbing activity occurs.
- Do not disturb an area until it is necessary for the construction activity to proceed
- Cover or stabilize as soon as possible.
- Time the construction activities to reduce the impacts from seasonal climatic changes or weather events.
- The construction of filtration BMP's should wait until the end of the construction project when upstream drainage areas have been stabilized.
- Do not remove the temporary perimeter controls until after all upstream areas are stabilized.

Four Step Process

The following four step process is recommended for selecting structural BMP's in developing urban areas:

Step 1: Employ Runoff Reduction Practices

This development incorporates wider rights-of-way than other developments, thus increasing the amount of pervious area within the right-of-way. With the rights-of-way within Meridian Ranch at 60 ft. instead of the normal 50 ft., the amount of pervious area per lineal foot is tripled from 5' wide to 15' wide.

The project has over thirty acres of open space, accounting for over 28% of the entire project, creating a lower density development.

Homeowners and builders are encouraged to direct roof drains to the sideyards where the runoff will travel overland to the streets and creating an opportunity to allow the runoff to infiltrate into the ground.

Please update as the proposed roadways have a 50' ROW not 60' per the PUD development plan

for selecting structural BMP's in

the open space values do not match the above fee calculations. Revise accordingly.

south

Step 2: Stabilize Drainageways

The drainage swale located adjacent and south of the project was designed to have a wide flat bottom and slope reducing the velocity of the concentrated flow traveling along the drainageway. The construction of the swale also included erosion control along the entire length of the swale.

Step 3: Provide Water Quality Capture Volume (WQCV)

An existing extended detention pond with water quality capture volume is located to the east of the project that was designed to accommodate the runoff from this development.

Step 4: Consider Need for Industrial and Commercial BMP's

This project is neither industrial nor commercial and therefore this section does not apply.

Detention Pond

The detention ponds will act as the primary water quality control for the areas within the project boundaries. Runoff will be collected by the proposed storm drainage system and diverted into the detention pond where practical. The pond will serve a dual purpose: first, by facilitating the settling of sediment in runoff during and after construction (by means of the WQCV) and, second, by maintaining runoff at or below existing levels.

Silt Fence

Silt fence will be placed along downstream limits of disturbed areas. This will prevent suspended sediment from leaving the site during infrastructure construction. Silt fencing is to remain in place until vegetation is reestablished.

Erosion Bales

Erosion bales will be placed ten (10) feet from the inlet of all culverts during construction to prevent culverts from filling with sediment. Erosion bales will remain in place until vegetation is reestablished. Erosion bale checks will be used on slopes greater than 1 percent to reduce flow velocities until vegetation is reestablished.

Miscellaneous

Best erosion control practices will be utilized as deemed necessary by the Contractor or Engineer and are not limited to the measures described above.

REFERENCES

1. “City of Colorado Springs/El Paso County Drainage Criteria Manual” September 1987, Revised November 1991, Revised October 1994.
2. Chapter 6, Hydrology and Chapter 11, Storage, Section 3.2.1 of the “City of Colorado Springs Drainage Criteria Manual” May 2014.
3. “Volume 2, El Paso County/City of Colorado Springs Drainage Criteria Manual-Stormwater Quality Policies, Procedures and Best Management Practices” November 1, 2002.
4. Flood Insurance Rate Study for El Paso County, Colorado and Incorporated Areas. Federal Emergency Management Agency, Revised March 17, 1997.
5. Soils Survey of El Paso County area, Natural Resources Conservation Services of Colorado.
6. Master Development Drainage Plan Meridian Ranch. August 2000. Prepared by URS Corp.
7. Revision to Master Development Drainage Plan Meridian Ranch. July 2021. Prepared by Tech Contractors.
8. Master Development Drainage Plan Latigo Trails. October 2001. Prepared by URS Corp.
9. Final Drainage Report for Estates at Rolling Hills Ranch Filing 2. September 2020. Prepared by Tech Contractors.
10. Final Drainage Report for Rolling Hills Ranch Filing 2. November 2020. Prepared by Tech Contractors.
11. Final Drainage Report for Rolling Hills Ranch Filing 3. May 2021. Prepared by Tech Contractors.

Appendices

Appendix A - HEC-HMS Data

Input Data

The Sanctuary PDR-FDR

BASIN	AREA		CURVE NO.	LAG TIME (min)
	(acre)	(mi ²)		
HISTORIC				
OS05	37	0.0578	61.0	15.2
OS06	84	0.1313	61.0	18.7
OS07	21	0.0328	63.1	15.4
OS08	26	0.0406	65.7	15.9
OS09	98	0.1527	65.0	29.5
HG01	35	0.0547	61.0	19.6
HG02	58	0.0906	61.0	25.4
HG03	117	0.1828	61.1	33.8
HG04	57	0.0891	61.0	30.7
HG05	72	0.1125	61.0	31.8
HG06A	88	0.1375	61.0	43.2
HG06B	66	0.1031	61.0	49.5
HG07	63	0.0984	61.0	28.3
HG08	85	0.1328	61.0	22.9
HG09	114	0.1781	61.0	35.6
HG10	88	0.1375	61.0	61.4
HG11	131	0.2047	61.0	40.4
HG12	83	0.1297	61.0	32.0
HG13	54	0.0844	63.1	21.2
HG14	147	0.2297	61.0	45.1
HG15	164	0.2563	61.0	65.1
HG18	21	0.0328	61.0	14.1
HG19	3	0.0047	61.0	6.1
HG20	1	0.0016	61.0	6.9
HG21	14	0.0219	61.0	13.8

BASIN	AREA		CURVE NO.	LAG TIME (min)
	(acre)	(mi ²)		
INTERIM				
OS05	37	0.0578	61.0	15.2
OS06	84	0.1313	61.0	18.7
OS07ab	11	0.0170	61.0	13.9
OS07c	10	0.0158	61.0	10.9
OS07d	2	0.0036	61.0	13.1
OS08a	30	0.0469	61.4	19.0
OS08b	75	0.1167	64.4	25.6
OS09a	18	0.0279	62.2	21.0
OS09b	46	0.0711	61.2	37.7
FG01	34	0.0538	66.4	33.8
FG02	25	0.0391	64.6	16.1
FG03	13	0.0203	68.0	11.6
FG04	11	0.0172	68.0	7.6
FG05	37	0.0580	70.1	28.4
FG06	43	0.0675	66.1	18.4
FG21a	6	0.0095	62.6	21.4
FG21b	10	0.0150	73.1	12.7
FG22	90	0.1400	68.8	20.3
FG23a	14	0.0216	68.6	18.0
FG23b	15	0.0235	62.5	15.0
FG23c	7	0.0109	65.4	12.1
FG24a	23	0.0359	63.1	21.9
FG24b	38	0.0589	67.3	26.6
FG24c	19	0.0291	67.0	18.1
FG24d	17	0.0262	73.7	19.2
FG25	69	0.1084	74.1	23.8
FG26	36	0.0570	66.9	20.9
FG27	43	0.0679	82.9	31.0
FG28	12	0.0184	64.1	14.8
FG29	63	0.0982	61.2	19.1
FG32	26	0.0402	61.0	23.9
FG34	18	0.0275	62.6	17.0
FG35	18	0.0282	61.7	14.2
FG36	18	0.0286	65.9	24.2
FG37	51	0.0797	63.5	20.2

BASIN	AREA		CURVE NO.	LAG TIME (min)
	(acre)	(mi ²)		
FUTURE				
OS05	37	0.0578	61.0	15.2
OS06	84	0.1313	61.0	18.7
OS07ab	11	0.0170	61.0	13.9
OS07c	19	0.0296	61.0	17.4
OS07d	2	0.0034	61.0	13.1
OS08a	16	0.0251	61.0	16.7
OS08b	11	0.0165	61.0	20.3
OS09a	6	0.0093	61.0	20.9
OS09b	28	0.0435	61.0	24.3
FG01	34	0.0538	66.4	33.8
FG02	25	0.0391	64.6	16.1
FG03	13	0.0203	68.0	11.6
FG04	11	0.0172	68.0	7.6
FG05	37	0.0580	70.1	28.4
FG06	43	0.0675	66.1	18.4
FG21a	6	0.0095	62.6	21.4
FG21b	10	0.0150	73.1	12.7
FG22	87	0.1354	69.0	20.3
FG23a	14	0.0216	68.6	18.0
FG23b	15	0.0236	61.8	15.0
FG23c	7	0.0109	65.2	12.1
FG24a	22	0.0348	64.3	21.9
FG24b	38	0.0589	73.4	14.5
FG24c	19	0.0291	75.0	14.7
FG24d	17	0.0262	76.4	13.9
FG25	69	0.1084	74.1	23.8
FG26	36	0.0570	78.0	25.5
FG27	43	0.0679	83.3	22.1
FG28	12	0.0184	64.1	14.8
FG29	63	0.0983	61.2	19.1
FG32	26	0.0402	80.0	23.9
FG34	18	0.0275	63.7	22.1
FG35	18	0.0282	65.5	14.2
FG36	18	0.0286	65.9	24.2
FG37	51	0.0797	63.5	20.2



NOAA Atlas 14, Volume 8, Version 2
 Location name: Peyton, Colorado, USA*
 Latitude: 38,9783°, Longitude: -104,5842°
 Elevation: 7054.14 ft**
 * source: ESRI Maps
 ** source: USGS



POINT PRECIPITATION FREQUENCY ESTIMATES

Sanja Perica, Deborah Martin, Sandra Pavlovic, Ishani Roy, Michael St. Laurent, Carl Trypanuk,
 Dale Unruh, Michael Yekta, Geoffrey Bonnin

NOAA, National Weather Service, Silver Spring, Maryland

[PF tabular](#) | [PF graphical](#) | [Maps & aeriels](#)

PF tabular

PDS-based point precipitation frequency estimates with 90% confidence intervals (in inches)¹										
Duration	Average recurrence interval (years)									
	1	2	5	10	25	50	100	200	500	1000
5-min	0.239 (0.190-0.301)	0.291 (0.232-0.367)	0.381 (0.302-0.482)	0.460 (0.363-0.585)	0.576 (0.442-0.764)	0.670 (0.501-0.899)	0.770 (0.556-1.06)	0.875 (0.606-1.23)	1.02 (0.680-1.48)	1.14 (0.737-1.66)
10-min	0.349 (0.278-0.441)	0.426 (0.339-0.538)	0.558 (0.443-0.706)	0.674 (0.532-0.857)	0.843 (0.647-1.12)	0.982 (0.734-1.32)	1.13 (0.814-1.55)	1.28 (0.888-1.80)	1.50 (0.996-2.16)	1.67 (1.08-2.44)
15-min	0.426 (0.340-0.538)	0.519 (0.413-0.656)	0.680 (0.540-0.861)	0.822 (0.648-1.04)	1.03 (0.789-1.36)	1.20 (0.895-1.61)	1.37 (0.993-1.89)	1.56 (1.08-2.20)	1.82 (1.22-2.64)	2.03 (1.31-2.97)
30-min	0.608 (0.485-0.768)	0.741 (0.590-0.936)	0.969 (0.769-1.23)	1.17 (0.923-1.49)	1.46 (1.12-1.94)	1.70 (1.27-2.28)	1.95 (1.41-2.68)	2.21 (1.53-3.12)	2.58 (1.72-3.73)	2.87 (1.86-4.20)
60-min	0.778 (0.620-0.982)	0.934 (0.744-1.18)	1.21 (0.962-1.54)	1.47 (1.16-1.86)	1.84 (1.42-2.46)	2.16 (1.62-2.91)	2.50 (1.81-3.44)	2.87 (1.99-4.05)	3.38 (2.26-4.91)	3.80 (2.46-5.56)
2-hr	0.948 (0.762-1.19)	1.13 (0.905-1.41)	1.46 (1.16-1.83)	1.76 (1.40-2.22)	2.23 (1.73-2.96)	2.62 (1.99-3.51)	3.05 (2.23-4.18)	3.52 (2.47-4.95)	4.19 (2.82-6.04)	4.73 (3.09-6.87)
3-hr	1.04 (0.839-1.29)	1.22 (0.986-1.52)	1.57 (1.26-1.96)	1.90 (1.51-2.38)	2.41 (1.90-3.21)	2.86 (2.18-3.83)	3.35 (2.47-4.59)	3.90 (2.75-5.47)	4.68 (3.18-6.75)	5.33 (3.50-7.71)
6-hr	1.21 (0.980-1.49)	1.40 (1.14-1.73)	1.78 (1.44-2.21)	2.16 (1.74-2.68)	2.76 (2.19-3.65)	3.29 (2.53-4.38)	3.88 (2.88-5.28)	4.53 (3.23-6.34)	5.49 (3.76-7.88)	6.29 (4.17-9.04)
12-hr	1.39 (1.14-1.70)	1.62 (1.33-1.98)	2.06 (1.68-2.53)	2.48 (2.02-3.06)	3.16 (2.53-4.14)	3.76 (2.92-4.96)	4.42 (3.31-5.97)	5.15 (3.70-7.14)	6.22 (4.30-8.85)	7.10 (4.75-10.1)
24-hr	1.61 (1.33-1.95)	1.88 (1.55-2.29)	2.39 (1.97-2.92)	2.88 (2.35-3.52)	3.63 (2.91-4.69)	4.27 (3.34-5.58)	4.98 (3.75-6.66)	5.75 (4.17-7.90)	6.87 (4.78-9.70)	7.79 (5.25-11.1)
2-day	1.86 (1.55-2.24)	2.19 (1.83-2.64)	2.79 (2.31-3.36)	3.33 (2.75-4.04)	4.15 (3.35-5.30)	4.85 (3.81-6.25)	5.59 (4.25-7.39)	6.40 (4.67-8.70)	7.55 (5.30-10.6)	8.49 (5.77-12.0)
3-day	2.04 (1.71-2.45)	2.41 (2.01-2.88)	3.05 (2.54-3.66)	3.63 (3.01-4.38)	4.51 (3.65-5.71)	5.24 (4.14-6.72)	6.03 (4.59-7.92)	6.87 (5.03-9.29)	8.07 (5.69-11.2)	9.04 (6.18-12.7)
4-day	2.20 (1.85-2.62)	2.58 (2.16-3.08)	3.25 (2.72-3.89)	3.86 (3.21-4.63)	4.77 (3.87-6.01)	5.53 (4.38-7.06)	6.34 (4.85-8.31)	7.22 (5.31-9.73)	8.46 (5.98-11.7)	9.46 (6.50-13.2)
7-day	2.60 (2.20-3.08)	3.00 (2.54-3.56)	3.71 (3.13-4.41)	4.36 (3.65-5.20)	5.33 (4.36-6.67)	6.14 (4.89-7.78)	7.00 (5.40-9.11)	7.93 (5.87-10.6)	9.26 (6.59-12.8)	10.3 (7.14-14.4)
10-day	2.96 (2.51-3.48)	3.39 (2.88-4.00)	4.16 (3.52-4.92)	4.85 (4.08-5.76)	5.88 (4.82-7.31)	6.73 (5.38-8.48)	7.63 (5.91-9.88)	8.61 (6.39-11.5)	9.97 (7.13-13.7)	11.1 (7.70-15.4)
20-day	3.95 (3.38-4.61)	4.55 (3.89-5.32)	5.57 (4.75-6.52)	6.44 (5.46-7.58)	7.68 (6.32-9.39)	8.67 (6.97-10.8)	9.69 (7.54-12.4)	10.8 (8.04-14.1)	12.2 (8.79-16.6)	13.3 (9.36-18.4)
30-day	4.75 (4.09-5.51)	5.49 (4.72-6.38)	6.70 (5.74-7.81)	7.72 (6.58-9.04)	9.12 (7.52-11.1)	10.2 (8.24-12.6)	11.3 (8.83-14.3)	12.4 (9.32-16.2)	13.9 (10.1-18.7)	15.0 (10.6-20.6)
45-day	5.73 (4.96-6.62)	6.62 (5.72-7.65)	8.05 (6.93-9.33)	9.21 (7.89-10.7)	10.8 (8.91-12.9)	12.0 (9.68-14.6)	13.1 (10.3-16.5)	14.3 (10.7-18.5)	15.8 (11.4-21.1)	16.9 (12.0-23.0)
60-day	6.56 (5.70-7.55)	7.55 (6.55-8.69)	9.12 (7.88-10.5)	10.4 (8.92-12.0)	12.1 (9.98-14.4)	13.3 (10.8-16.1)	14.5 (11.4-18.1)	15.6 (11.8-20.2)	17.1 (12.5-22.8)	18.2 (12.9-24.8)

¹ Precipitation frequency (PF) estimates in this table are based on frequency analysis of partial duration series (PDS). Numbers in parenthesis are PF estimates at lower and upper bounds of the 90% confidence interval. The probability that precipitation frequency estimates (for a given duration and average recurrence interval) will be greater than the upper bound (or less than the lower bound) is 5%. Estimates at upper bounds are not checked against probable maximum precipitation (PMP) estimates and may be higher than currently valid PMP values. Please refer to NOAA Atlas 14 document for more information.

[Back to Top](#)

HISTORIC SCS (100-YEAR)				
HYDROLOGIC ELEMENT	DRAINAGE AREA (SQ. MI.)	DISCHARGE PEAK Q100 (CFS)	TIME OF PEAK	TOTAL VOLUME Q100 (AC. FT.)
OS06	0.1313	80	01Jul2015, 12:12	9.3
OS06-G02	0.1313	77	01Jul2015, 12:24	9.2
OS05	0.0578	39	01Jul2015, 12:12	4.1
OS05-G01	0.0578	38	01Jul2015, 12:12	4.1
HG01	0.0547	32	01Jul2015, 12:12	3.9
G01	0.1125	70	01Jul2015, 12:12	7.9
G01-G02	0.1125	68	01Jul2015, 12:24	7.8
HG02	0.0906	45	01Jul2015, 12:24	6.4
G02	0.3344	191	01Jul2015, 12:24	23
G02-G03	0.3344	190	01Jul2015, 12:30	23
HG03	0.1828	77	01Jul2015, 12:30	13
OS07	0.0328	25	01Jul2015, 12:12	2.6
OS07-G03	0.0328	24	01Jul2015, 12:30	2.5
G03	0.5500	291	01Jul2015, 12:30	38
G03-G04	0.5500	281	01Jul2015, 12:30	38
OS09	0.1547	91	01Jul2015, 12:24	13
OS09-G04	0.1547	90	01Jul2015, 12:30	13
HG04	0.0891	40	01Jul2015, 12:30	6.3
HG05	0.1125	49	01Jul2015, 12:30	7.9
OS08	0.0406	35	01Jul2015, 12:12	3.6
OS08-G04	0.0406	34	01Jul2015, 12:30	3.5
G04	0.9469	493	01Jul2015, 12:30	69
G04-G05	0.9469	488	01Jul2015, 12:36	68
HG06A	0.1375	49	01Jul2015, 12:42	9.6
G05	1.0844	536	01Jul2015, 12:36	78
G05-G06	1.0844	520	01Jul2015, 12:36	78
HG06B	0.1031	33	01Jul2015, 12:48	7.2
G06	1.1875	551	01Jul2015, 12:42	85

Highlighted green rows reference key design points (Typical all charts this section)

GIECK HISTORIC CONDITIONS

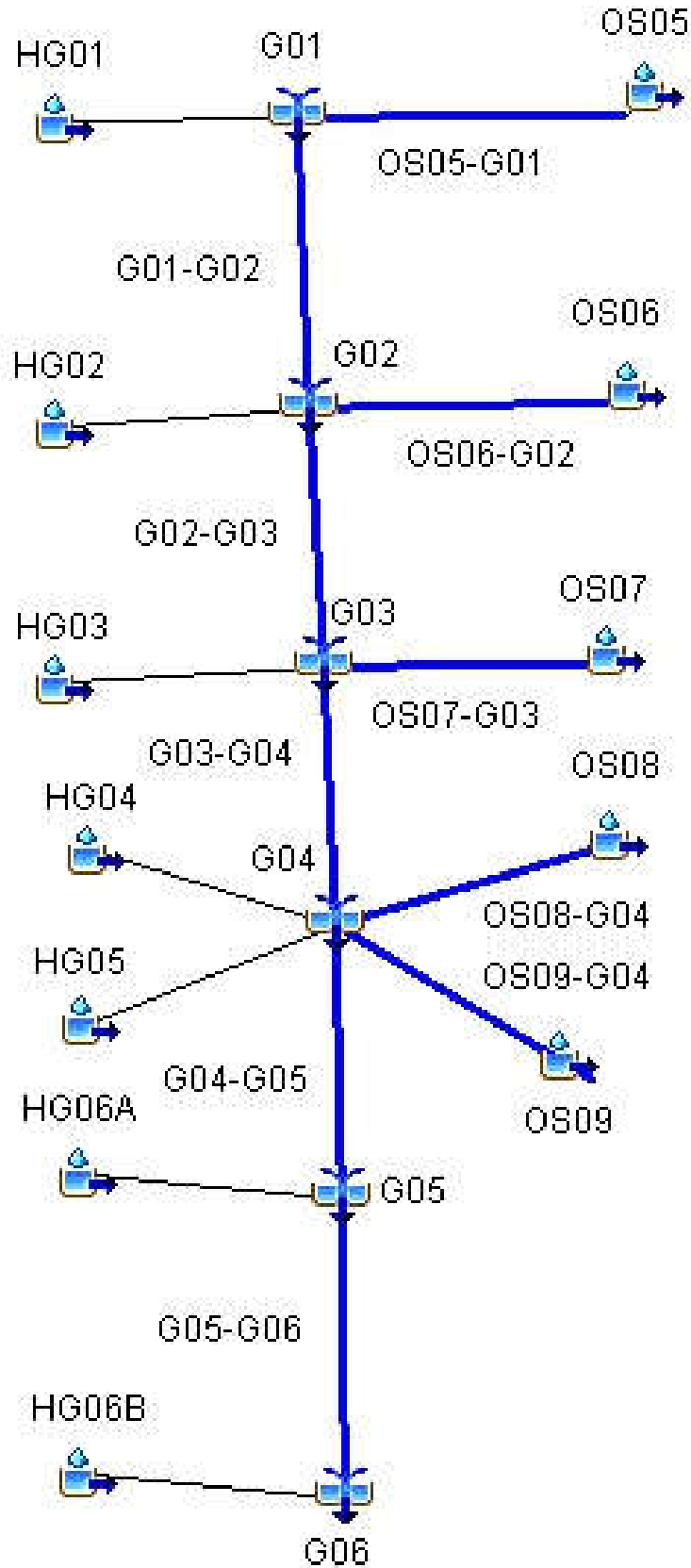

HISTORIC SCS (50-YEAR)				
HYDROLOGIC ELEMENT	DRAINAGE AREA (SQ. MI.)	DISCHARGE PEAK Q50 (CFS)	TIME OF PEAK	TOTAL VOLUME Q50 (AC. FT.)
OS06	0.1313	52	01Jul2015, 12:12	6.5
OS06-G02	0.1313	52	01Jul2015, 12:24	6.4
OS05	0.0578	26	01Jul2015, 12:12	2.9
OS05-G01	0.0578	25	01Jul2015, 12:18	2.9
HG01	0.0547	21	01Jul2015, 12:18	2.7
G01	0.1125	46	01Jul2015, 12:18	5.6
G01-G02	0.1125	46	01Jul2015, 12:24	5.5
HG02	0.0906	30	01Jul2015, 12:24	4.5
G02	0.3344	127	01Jul2015, 12:24	16
G02-G03	0.3344	125	01Jul2015, 12:30	16
HG03	0.1828	51	01Jul2015, 12:30	9.1
OS07	0.0328	17	01Jul2015, 12:12	1.9
OS07-G03	0.0328	17	01Jul2015, 12:30	1.8
G03	0.5500	192	01Jul2015, 12:30	27
G03-G04	0.5500	189	01Jul2015, 12:36	27
OS09	0.1547	63	01Jul2015, 12:24	9.6
OS09-G04	0.1547	62	01Jul2015, 12:36	9.4
HG04	0.0891	26	01Jul2015, 12:30	4.4
HG05	0.1125	32	01Jul2015, 12:30	5.6
OS08	0.0406	25	01Jul2015, 12:12	2.6
OS08-G04	0.0406	24	01Jul2015, 12:36	2.5
G04	0.9469	332	01Jul2015, 12:36	49
G04-G05	0.9469	318	01Jul2015, 12:42	48
HG06A	0.1375	32	01Jul2015, 12:42	6.7
G05	1.0844	350	01Jul2015, 12:42	55
G05-G06	1.0844	348	01Jul2015, 12:42	55
HG06B	0.1031	22	01Jul2015, 12:54	5.0
G06	1.1875	369	01Jul2015, 12:42	60

Highlighted green rows reference key design points (Typical all charts this section)

HISTORIC SCS (10-YEAR)				
HYDROLOGIC ELEMENT	DRAINAGE AREA (SQ. MI.)	DISCHARGE PEAK Q10 (CFS)	TIME OF PEAK	TOTAL VOLUME Q10 (AC. FT.)
OS06	0.1313	12	01Jul2015, 12:18	2.2
OS06-G02	0.1313	11	01Jul2015, 12:30	2.1
OS05	0.0578	5.6	01Jul2015, 12:12	1.0
OS05-G01	0.0578	5.5	01Jul2015, 12:24	0.9
HG01	0.0547	4.7	01Jul2015, 12:18	0.9
G01	0.1125	10	01Jul2015, 12:24	1.9
G01-G02	0.1125	10	01Jul2015, 12:36	1.8
HG02	0.0906	6.7	01Jul2015, 12:30	1.5
G02	0.3344	27	01Jul2015, 12:36	5.4
G02-G03	0.3344	27	01Jul2015, 12:48	5.3
HG03	0.1828	12	01Jul2015, 12:42	3.0
OS07	0.0328	4.5	01Jul2015, 12:12	0.7
OS07-G03	0.0328	4.3	01Jul2015, 12:48	0.7
G03	0.5500	42	01Jul2015, 12:48	8.9
G03-G04	0.5500	42	01Jul2015, 12:54	8.8
OS09	0.1547	19	01Jul2015, 12:30	3.6
OS09-G04	0.1547	18	01Jul2015, 12:42	3.5
HG04	0.0891	5.9	01Jul2015, 12:36	1.5
HG05	0.1125	7.4	01Jul2015, 12:36	1.8
OS08	0.0406	7.7	01Jul2015, 12:12	1.0
OS08-G04	0.0406	7.4	01Jul2015, 12:48	1.0
G04	0.9469	76	01Jul2015, 12:54	17
G04-G05	0.9469	76	01Jul2015, 12:54	16
HG06A	0.1375	7.6	01Jul2015, 12:54	2.2
G05	1.0844	84	01Jul2015, 12:54	19
G05-G06	1.0844	83	01Jul2015, 13:00	19
HG06B	0.1031	5.3	01Jul2015, 13:00	1.7
G06	1.1875	88	01Jul2015, 13:00	20

Highlighted green rows reference key design points (Typical all charts this section)

HISTORIC SCS (5-YEAR)				
HYDROLOGIC ELEMENT	DRAINAGE AREA (SQ. MI.)	DISCHARGE PEAK Q5 (CFS)	TIME OF PEAK	TOTAL VOLUME Q5 (AC. FT.)
OS06	0.1313	3.8	01Jul2015, 12:24	1.1
OS06-G02	0.1313	3.7	01Jul2015, 12:42	1.1
OS05	0.0578	1.8	01Jul2015, 12:18	0.5
OS05-G01	0.0578	1.7	01Jul2015, 12:30	0.5
HG01	0.0547	1.5	01Jul2015, 12:24	0.5
G01	0.1125	3.2	01Jul2015, 12:30	1.0
G01-G02	0.1125	3.2	01Jul2015, 12:48	0.9
HG02	0.0906	2.3	01Jul2015, 12:36	0.8
G02	0.3344	9.0	01Jul2015, 12:42	2.8
G02-G03	0.3344	9.0	01Jul2015, 13:00	2.7
HG03	0.1828	4.3	01Jul2015, 12:48	1.6
OS07	0.0328	1.7	01Jul2015, 12:18	0.4
OS07-G03	0.0328	1.7	01Jul2015, 13:00	0.4
G03	0.5500	15	01Jul2015, 13:00	4.6
G03-G04	0.5500	14	01Jul2015, 13:12	4.5
OS09	0.1547	8.3	01Jul2015, 12:36	2.1
OS09-G04	0.1547	8.3	01Jul2015, 12:48	2.0
HG04	0.0891	2.1	01Jul2015, 12:42	0.8
HG05	0.1125	2.6	01Jul2015, 12:42	0.9
OS08	0.0406	3.4	01Jul2015, 12:12	0.6
OS08-G04	0.0406	3.4	01Jul2015, 13:00	0.6
G04	0.9469	28	01Jul2015, 13:12	8.7
G04-G05	0.9469	27	01Jul2015, 13:18	8.6
HG06A	0.1375	2.9	01Jul2015, 13:00	1.1
G05	1.0844	30	01Jul2015, 13:18	9.8
G05-G06	1.0844	30	01Jul2015, 13:24	9.6
HG06B	0.1031	2.0	01Jul2015, 13:12	0.9
G06	1.1875	32	01Jul2015, 13:24	10

Highlighted green rows reference key design points (Typical all charts this section)

HISTORIC SCS (2-YEAR)				
HYDROLOGIC ELEMENT	DRAINAGE AREA (SQ. MI.)	DISCHARGE PEAK Q2 (CFS)	TIME OF PEAK	TOTAL VOLUME Q2 (AC. FT.)
OS06	0.1313	0.5	01Jul2015, 13:30	0.3
OS06-G02	0.1313	0.5	01Jul2015, 14:00	0.3
OS05	0.0578	0.2	01Jul2015, 13:24	0.2
OS05-G01	0.0578	0.2	01Jul2015, 13:42	0.2
HG01	0.0547	0.2	01Jul2015, 13:36	0.1
G01	0.1125	0.5	01Jul2015, 13:36	0.3
G01-G02	0.1125	0.5	01Jul2015, 14:06	0.3
HG02	0.0906	0.4	01Jul2015, 13:42	0.2
G02	0.3344	1.3	01Jul2015, 14:00	0.8
G02-G03	0.3344	1.3	01Jul2015, 14:30	0.8
HG03	0.1828	0.7	01Jul2015, 13:54	0.5
OS07	0.0328	0.3	01Jul2015, 12:54	0.1
OS07-G03	0.0328	0.3	01Jul2015, 14:12	0.1
G03	0.5500	2.3	01Jul2015, 14:24	1.4
G03-G04	0.5500	2.3	01Jul2015, 14:42	1.3
OS09	0.1547	1.9	01Jul2015, 12:54	0.8
OS09-G04	0.1547	1.9	01Jul2015, 13:18	0.8
HG04	0.0891	0.3	01Jul2015, 13:48	0.2
HG05	0.1125	0.4	01Jul2015, 13:54	0.3
OS08	0.0406	0.7	01Jul2015, 12:24	0.2
OS08-G04	0.0406	0.7	01Jul2015, 13:36	0.2
G04	0.9469	4.7	01Jul2015, 14:36	2.8
G04-G05	0.9469	4.7	01Jul2015, 14:48	2.8
HG06A	0.1375	0.5	01Jul2015, 14:12	0.3
G05	1.0844	5.2	01Jul2015, 14:48	3.1
G05-G06	1.0844	5.2	01Jul2015, 15:00	3.0
HG06B	0.1031	0.4	01Jul2015, 14:24	0.3
G06	1.1875	5.5	01Jul2015, 15:00	3.3

Highlighted green rows reference key design points (Typical all charts this section)

INTERIM SCS (100-YEAR)				
HYDROLOGIC ELEMENT	DRAINAGE AREA (SQ. MI.)	PEAK DISCHARGE Q100 (CFS)	TIME OF PEAK	TOTAL VOLUME Q100 (AC. FT.)
OS06	0.1313	80	01Jul2015, 12:12	9.3
G1a	0.1313	80	01Jul2015, 12:12	9.3
G1a-G2	0.1313	79	01Jul2015, 12:18	9.2
OS05	0.0578	39	01Jul2015, 12:12	4.1
OS05-G1	0.0578	39	01Jul2015, 12:12	4.1
FG01	0.0538	31	01Jul2015, 12:30	4.9
FG01-G1	0.0538	31	01Jul2015, 12:30	4.9
G1	0.1116	61	01Jul2015, 12:18	9.0
G1-G2	0.1116	61	01Jul2015, 12:18	9.0
FG02	0.0391	32	01Jul2015, 12:12	3.3
G2	0.2820	167	01Jul2015, 12:18	21
G2-G3	0.2820	163	01Jul2015, 12:18	21
FG03	0.0203	24	01Jul2015, 12:06	2.0
FG04	0.0172	22	01Jul2015, 12:00	1.7
G3	0.3195	185	01Jul2015, 12:18	25
FG06	0.0675	56	01Jul2015, 12:12	6.1
FG05	0.0580	45	01Jul2015, 12:24	6.1
OS07ab	0.0170	12	01Jul2015, 12:06	1.2
OS07ab-POND F	0.0170	12	01Jul2015, 12:18	1.2
POND F IN	0.4620	293	01Jul2015, 12:18	38
POND F	0.4620	178	01Jul2015, 12:42	36
POND F-G7	0.4620	177	01Jul2015, 12:42	36
OS07c	0.0158	13	01Jul2015, 12:06	1.1
OS07c-G4	0.0158	13	01Jul2015, 12:12	1.1
FG21a	0.0095	5.9	01Jul2015, 12:18	0.7
G4	0.0253	19	01Jul2015, 12:12	1.8
G4-G7	0.0253	17	01Jul2015, 12:18	1.8
FG21b	0.0150	21	01Jul2015, 12:06	1.8
G7	0.5023	189	01Jul2015, 12:42	39
G7-G8	0.5023	188	01Jul2015, 12:42	39
FG22	0.1400	124	01Jul2015, 12:12	14
OS08a	0.0469	29	01Jul2015, 12:12	3.4
OS08-G8	0.0469	29	01Jul2015, 12:18	3.4
FG23a	0.0216	21	01Jul2015, 12:12	2.2
OS07d	0.0036	2.6	01Jul2015, 12:06	0.3
OS07d-G8	0.0036	2.6	01Jul2015, 12:12	0.3
G8	0.7144	283	01Jul2015, 12:30	59
G8-G10	0.7144	282	01Jul2015, 12:36	59
OS08b	0.1167	72	01Jul2015, 12:18	9.7
OS08b-G9a	0.1167	71	01Jul2015, 12:30	9.6
FG24b	0.0589	41	01Jul2015, 12:24	5.6
FG24a	0.0359	23	01Jul2015, 12:18	2.8
OS09a	0.0279	17	01Jul2015, 12:18	2.1
OS09a-G9a	0.0279	17	01Jul2015, 12:24	2.1
G9a	0.2394	148	01Jul2015, 12:24	20

INTERIM SCS (100-YEAR)				
HYDROLOGIC ELEMENT	DRAINAGE AREA (SQ. MI.)	PEAK DISCHARGE Q100 (CFS)	TIME OF PEAK	TOTAL VOLUME Q100 (AC. FT.)
G9a-G9b	0.2394	145	01Jul2015, 12:30	20
FG24c	0.0291	26	01Jul2015, 12:12	2.7
FG24d	0.0262	30	01Jul2015, 12:12	3.2
G9b	0.2947	185	01Jul2015, 12:24	26
REX RD WQCV	0.2947	173	01Jul2015, 12:30	26
G9b-G10	0.2947	172	01Jul2015, 12:30	26
FG23b	0.0235	18	01Jul2015, 12:12	1.8
G10	1.0326	459	01Jul2015, 12:36	86
G10-G11	1.0326	458	01Jul2015, 12:36	86
FG23c	0.0109	11	01Jul2015, 12:06	1.0
G11	1.0435	461	01Jul2015, 12:36	87
FG25	0.1084	111	01Jul2015, 12:18	13
FG28	0.0184	15	01Jul2015, 12:12	1.5
POND G IN-W	1.1703	544	01Jul2015, 12:30	102
FG27	0.0679	81	01Jul2015, 12:24	11.2
FG26	0.0570	45	01Jul2015, 12:18	5.3
G13	0.0570	45	01Jul2015, 12:18	5.3
G13-POND G	0.0570	45	01Jul2015, 12:18	5.3
POND G IN-E	0.1249	123	01Jul2015, 12:24	16.5
POND G	1.2952	466	01Jul2015, 12:54	108
G12	1.2952	466	01Jul2015, 12:54	108
G12-G06	1.2952	465	01Jul2015, 13:00	107
FG29	0.0983	60	01Jul2015, 12:12	7.0
FG32	0.0402	21	01Jul2015, 12:18	2.8
FG32-G06	0.0402	21	01Jul2015, 12:24	2.8
G06	1.4337	491	01Jul2015, 12:54	117

Highlighted green rows reference key design points (Typical all charts this section)

GIECK INTERIM CONDITIONS

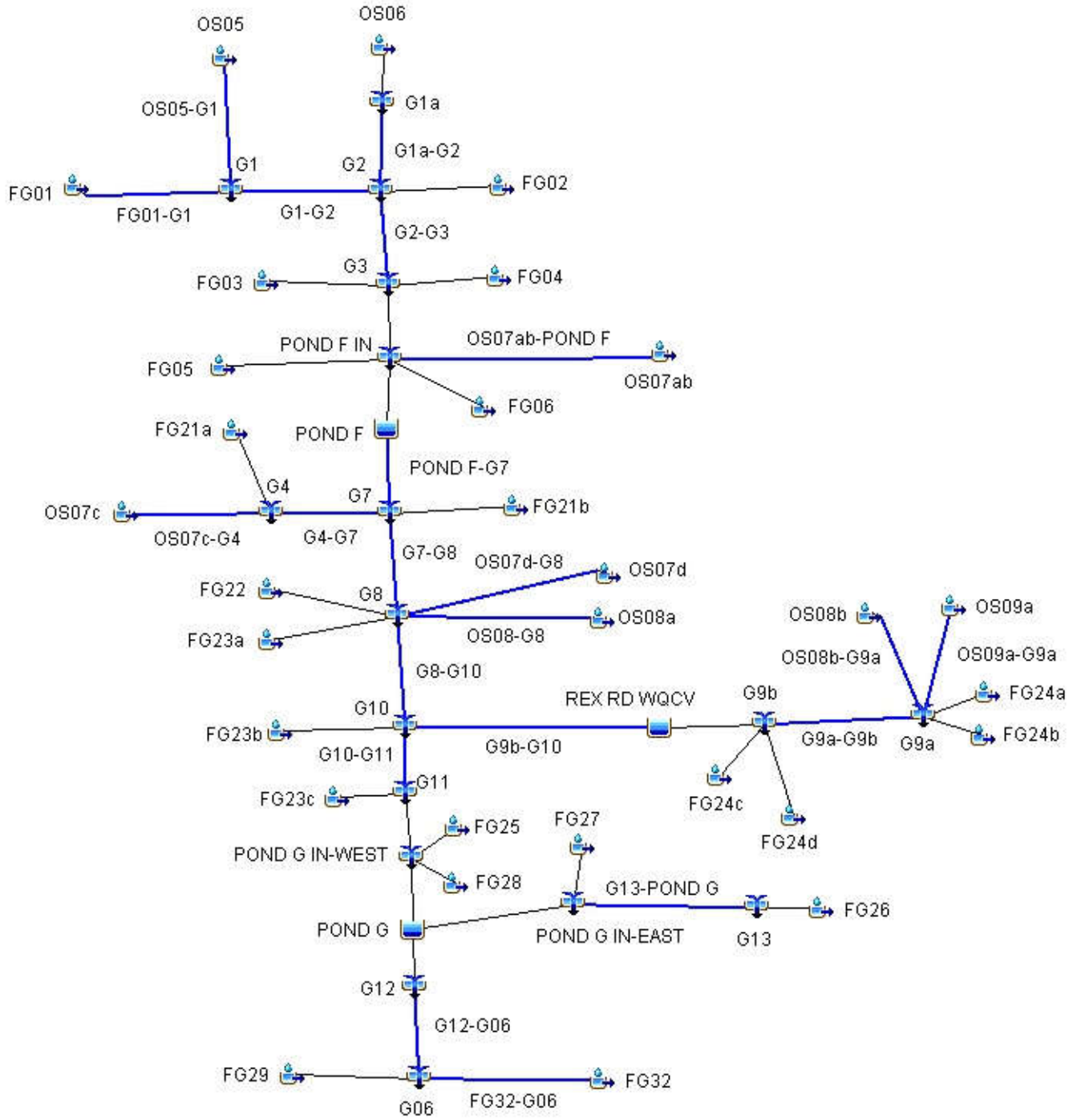

INTERIM SCS (50-YEAR)				
HYDROLOGIC ELEMENT	DRAINAGE AREA (SQ. MI.)	PEAK DISCHARGE Q50 (CFS)	TIME OF PEAK	TOTAL VOLUME Q50 (AC. FT.)
OS06	0.1313	52	01Jul2015, 12:12	6.5
G1a	0.1313	52	01Jul2015, 12:12	6.5
G1a-G2	0.1313	52	01Jul2015, 12:18	6.5
OS05	0.0578	26	01Jul2015, 12:12	2.9
OS05-G1	0.0578	25	01Jul2015, 12:12	2.9
FG01	0.0538	22	01Jul2015, 12:30	3.6
FG01-G1	0.0538	22	01Jul2015, 12:30	3.6
G1	0.1116	41	01Jul2015, 12:18	6.4
G1-G2	0.1116	41	01Jul2015, 12:18	6.4
FG02	0.0391	22	01Jul2015, 12:12	2.4
G2	0.2820	112	01Jul2015, 12:18	15
G2-G3	0.2820	108	01Jul2015, 12:24	15
FG03	0.0203	17	01Jul2015, 12:06	1.5
FG04	0.0172	16	01Jul2015, 12:00	1.3
G3	0.3195	123	01Jul2015, 12:18	18
FG06	0.0675	40	01Jul2015, 12:12	4.4
FG05	0.0580	33	01Jul2015, 12:24	4.6
OS07ab	0.0170	7.9	01Jul2015, 12:12	0.9
OS07ab-POND F	0.0170	7.6	01Jul2015, 12:18	0.8
POND F IN	0.4620	200	01Jul2015, 12:18	28
POND F	0.4620	121	01Jul2015, 12:42	26
POND F-G7	0.4620	120	01Jul2015, 12:48	26
OS07c	0.0158	8.6	01Jul2015, 12:06	0.8
OS07c-G4	0.0158	8.2	01Jul2015, 12:12	0.8
FG21a	0.0095	4.0	01Jul2015, 12:18	0.5
G4	0.0253	12	01Jul2015, 12:12	1.3
G4-G7	0.0253	12	01Jul2015, 12:18	1.3
FG21b	0.0150	16	01Jul2015, 12:06	1.4
G7	0.5023	127	01Jul2015, 12:48	28
G7-G8	0.5023	127	01Jul2015, 12:48	28
FG22	0.1400	90	01Jul2015, 12:12	11
OS08a	0.0469	19	01Jul2015, 12:12	2.4
OS08-G8	0.0469	19	01Jul2015, 12:18	2.4
FG23a	0.0216	15	01Jul2015, 12:12	1.6
OS07d	0.0036	1.7	01Jul2015, 12:06	0.2
OS07d-G8	0.0036	1.7	01Jul2015, 12:18	0.2
G8	0.7144	179	01Jul2015, 12:42	43
G8-G10	0.7144	179	01Jul2015, 12:48	42
OS08b	0.1167	49	01Jul2015, 12:24	7.0
OS08b-G9a	0.1167	49	01Jul2015, 12:30	6.9
FG24b	0.0589	30	01Jul2015, 12:24	4.1
FG24a	0.0359	15	01Jul2015, 12:18	2.0
OS09a	0.0279	11	01Jul2015, 12:18	1.5
OS09a-G9a	0.0279	11	01Jul2015, 12:30	1.5
G9a	0.2394	100	01Jul2015, 12:24	14

INTERIM SCS (50-YEAR)				
HYDROLOGIC ELEMENT	DRAINAGE AREA (SQ. MI.)	PEAK DISCHARGE Q50 (CFS)	TIME OF PEAK	TOTAL VOLUME Q50 (AC. FT.)
G9a-G9b	0.2394	100	01Jul2015, 12:30	14
FG24c	0.0291	18	01Jul2015, 12:12	2.0
FG24d	0.0262	23	01Jul2015, 12:12	2.4
G9b	0.2947	126	01Jul2015, 12:24	19
REX RD WQCV	0.2947	126	01Jul2015, 12:30	19
G9b-G10	0.2947	125	01Jul2015, 12:30	19
FG23b	0.0235	12	01Jul2015, 12:12	1.3
G10	1.0326	286	01Jul2015, 12:42	62
G10-G11	1.0326	285	01Jul2015, 12:42	62
FG23c	0.0109	7.7	01Jul2015, 12:06	0.7
G11	1.0435	287	01Jul2015, 12:42	63
FG25	0.1084	84	01Jul2015, 12:18	10
FG28	0.0184	10	01Jul2015, 12:12	1.1
POND G IN-WEST	1.1703	357	01Jul2015, 12:24	74
FG27	0.0679	64	01Jul2015, 12:24	8.9
FG26	0.0570	32	01Jul2015, 12:18	3.9
G13	0.0570	32	01Jul2015, 12:18	3.9
G13-POND G	0.0570	32	01Jul2015, 12:18	3.9
POND G IN-EAST	0.1249	95	01Jul2015, 12:24	13
POND G	1.2952	307	01Jul2015, 13:00	77
G12	1.2952	307	01Jul2015, 13:00	77
G12-G06	1.2952	307	01Jul2015, 13:06	77
FG29	0.0983	39	01Jul2015, 12:18	5.0
FG32	0.0402	14	01Jul2015, 12:18	2.0
FG32-G06	0.0402	14	01Jul2015, 12:24	2.0
G06	1.4337	323	01Jul2015, 13:06	84

Highlighted green rows reference key design points (Typical all charts this section)

INTERIM SCS (10-YEAR)				
HYDROLOGIC ELEMENT	DRAINAGE AREA (SQ. MI.)	PEAK DISCHARGE Q10 (CFS)	TIME OF PEAK	TOTAL VOLUME Q10 (AC. FT.)
OS06	0.1313	12	01Jul2015, 12:18	2.2
G1a	0.1313	12	01Jul2015, 12:18	2.2
G1a-G2	0.1313	11	01Jul2015, 12:24	2.1
OS05	0.0578	5.6	01Jul2015, 12:12	1.0
OS05-G1	0.0578	5.5	01Jul2015, 12:18	1.0
FG01	0.0538	7.0	01Jul2015, 12:36	1.4
FG01-G1	0.0538	7.0	01Jul2015, 12:36	1.4
G1	0.1116	11	01Jul2015, 12:24	2.3
G1-G2	0.1116	11	01Jul2015, 12:30	2.3
FG02	0.0391	6.4	01Jul2015, 12:12	0.9
G2	0.2820	27	01Jul2015, 12:24	5.4
G2-G3	0.2820	27	01Jul2015, 12:30	5.3
FG03	0.0203	5.9	01Jul2015, 12:06	0.6
FG04	0.0172	5.8	01Jul2015, 12:06	0.5
G3	0.3195	31	01Jul2015, 12:30	6.4
FG06	0.0675	12	01Jul2015, 12:18	1.7
FG05	0.0580	12	01Jul2015, 12:24	2.0
OS07ab	0.0170	1.8	01Jul2015, 12:12	0.3
OS07ab-POND F	0.0170	1.7	01Jul2015, 12:30	0.3
POND F IN	0.4620	54	01Jul2015, 12:24	10
POND F	0.4620	16	01Jul2015, 13:48	9.1
POND F-G7	0.4620	16	01Jul2015, 13:54	9.0
OS07c	0.0158	1.8	01Jul2015, 12:06	0.3
OS07c-G4	0.0158	1.8	01Jul2015, 12:18	0.3
FG21a	0.0095	1.0	01Jul2015, 12:24	0.2
G4	0.0253	2.8	01Jul2015, 12:18	0.4
G4-G7	0.0253	2.7	01Jul2015, 12:24	0.4
FG21b	0.0150	6.5	01Jul2015, 12:06	0.6
G7	0.5023	18	01Jul2015, 13:42	10
G7-G8	0.5023	18	01Jul2015, 13:42	9.9
FG22	0.1400	32	01Jul2015, 12:18	4.3
OS08a	0.0469	4.4	01Jul2015, 12:18	0.8
OS08-G8	0.0469	4.3	01Jul2015, 12:24	0.8
FG23a	0.0216	5.2	01Jul2015, 12:12	0.7
OS07d	0.0036	0.4	01Jul2015, 12:12	0.1
OS07d-G8	0.0036	0.4	01Jul2015, 12:24	0.1
G8	0.7144	48	01Jul2015, 12:18	16
G8-G10	0.7144	47	01Jul2015, 12:30	15
OS08b	0.1167	14	01Jul2015, 12:24	2.6
OS08b-G9a	0.1167	14	01Jul2015, 12:36	2.5
FG24b	0.0589	9.8	01Jul2015, 12:24	1.6
FG24a	0.0359	4.0	01Jul2015, 12:24	0.7
OS09a	0.0279	2.8	01Jul2015, 12:24	0.5
OS09a-G9a	0.0279	2.7	01Jul2015, 12:36	0.5
G9a	0.2394	28	01Jul2015, 12:36	5.4

INTERIM SCS (10-YEAR)				
HYDROLOGIC ELEMENT	DRAINAGE AREA (SQ. MI.)	PEAK DISCHARGE Q10 (CFS)	TIME OF PEAK	TOTAL VOLUME Q10 (AC. FT.)
G9a-G9b	0.2394	28	01Jul2015, 12:36	5.3
FG24c	0.0291	5.8	01Jul2015, 12:12	0.8
FG24d	0.0262	10	01Jul2015, 12:12	1.1
G9b	0.2947	36	01Jul2015, 12:36	7.3
REX RD WQCV	0.2947	35	01Jul2015, 12:36	7.1
G9b-G10	0.2947	35	01Jul2015, 12:42	7.1
FG23b	0.0235	3.0	01Jul2015, 12:12	0.5
G10	1.0326	80	01Jul2015, 12:30	23
G10-G11	1.0326	79	01Jul2015, 12:36	23
FG23c	0.0109	2.3	01Jul2015, 12:06	0.3
G11	1.0435	80	01Jul2015, 12:36	23
FG25	0.1084	36	01Jul2015, 12:18	4.7
FG28	0.0184	3.0	01Jul2015, 12:12	0.4
POND G IN-WEST	1.1703	112	01Jul2015, 12:30	28
FG27	0.0679	34	01Jul2015, 12:24	4.8
FG26	0.0570	11	01Jul2015, 12:18	1.5
G13	0.0570	11	01Jul2015, 12:18	1.5
G13-POND G	0.0570	10	01Jul2015, 12:24	1.5
POND G IN-EAST	0.1249	44	01Jul2015, 12:24	6.3
POND G	1.2952	50	01Jul2015, 14:06	26
G12	1.2952	50	01Jul2015, 14:06	26
G12-G06	1.2952	49	01Jul2015, 14:12	26
FG29	0.0983	8.9	01Jul2015, 12:18	1.7
FG32	0.0402	3.1	01Jul2015, 12:24	0.7
FG32-G06	0.0402	3.1	01Jul2015, 12:30	0.7
G06	1.4337	52	01Jul2015, 14:12	28

Highlighted green rows reference key design points (Typical all charts this section)

INTERIM SCS (5-YEAR)				
HYDROLOGIC ELEMENT	DRAINAGE AREA (SQ. MI.)	PEAK DISCHARGE Q5 (CFS)	TIME OF PEAK	TOTAL VOLUME Q5 (AC. FT.)
OS06	0.1313	3.8	01Jul2015, 12:24	1.1
G1a	0.1313	3.8	01Jul2015, 12:24	1.1
G1a-G2	0.1313	3.7	01Jul2015, 12:30	1.1
OS05	0.0578	1.8	01Jul2015, 12:18	0.5
OS05-G1	0.0578	1.7	01Jul2015, 12:24	0.5
FG01	0.0538	3.4	01Jul2015, 12:36	0.8
FG01-G1	0.0538	3.4	01Jul2015, 12:36	0.8
G1	0.1116	4.9	01Jul2015, 12:36	1.3
G1-G2	0.1116	4.8	01Jul2015, 12:36	1.3
FG02	0.0391	2.7	01Jul2015, 12:18	0.5
G2	0.2820	10	01Jul2015, 12:30	2.9
G2-G3	0.2820	10	01Jul2015, 12:42	2.9
FG03	0.0203	3.0	01Jul2015, 12:06	0.4
FG04	0.0172	3.1	01Jul2015, 12:06	0.3
G3	0.3195	12	01Jul2015, 12:36	3.5
FG06	0.0675	5.8	01Jul2015, 12:18	1.0
FG05	0.0580	6.7	01Jul2015, 12:30	1.2
OS07ab	0.0170	0.5	01Jul2015, 12:18	0.2
OS07ab-POND F	0.0170	0.5	01Jul2015, 12:42	0.1
POND F IN	0.4620	23	01Jul2015, 12:36	5.9
POND F	0.4620	8.0	01Jul2015, 14:12	4.8
POND F-G7	0.4620	8.0	01Jul2015, 14:24	4.8
OS07c	0.0158	0.6	01Jul2015, 12:12	0.1
OS07c-G4	0.0158	0.5	01Jul2015, 12:30	0.1
FG21a	0.0095	0.4	01Jul2015, 12:24	0.1
G4	0.0253	0.9	01Jul2015, 12:24	0.2
G4-G7	0.0253	0.9	01Jul2015, 12:30	0.2
FG21b	0.0150	3.9	01Jul2015, 12:06	0.4
G7	0.5023	8.7	01Jul2015, 14:18	5.4
G7-G8	0.5023	8.7	01Jul2015, 14:24	5.4
FG22	0.1400	17	01Jul2015, 12:18	2.7
OS08a	0.0469	1.5	01Jul2015, 12:24	0.4
OS08-G8	0.0469	1.5	01Jul2015, 12:30	0.4
FG23a	0.0216	2.7	01Jul2015, 12:18	0.4
OS07d	0.0036	0.1	01Jul2015, 12:18	0.0
OS07d-G8	0.0036	0.1	01Jul2015, 12:30	0.0
G8	0.7144	25	01Jul2015, 12:18	8.9
G8-G10	0.7144	24	01Jul2015, 12:30	8.6
OS08b	0.1167	6.1	01Jul2015, 12:30	1.5
OS08b-G9a	0.1167	6.0	01Jul2015, 12:48	1.4
FG24b	0.0589	4.9	01Jul2015, 12:30	1.0
FG24a	0.0359	1.6	01Jul2015, 12:24	0.4
OS09a	0.0279	1.0	01Jul2015, 12:24	0.3
OS09a-G9a	0.0279	1.0	01Jul2015, 12:48	0.3
G9a	0.2394	12	01Jul2015, 12:42	3.1

INTERIM SCS (5-YEAR)				
HYDROLOGIC ELEMENT	DRAINAGE AREA (SQ. MI.)	PEAK DISCHARGE Q5 (CFS)	TIME OF PEAK	TOTAL VOLUME Q5 (AC. FT.)
G9a-G9b	0.2394	12	01Jul2015, 12:48	3.0
FG24c	0.0291	2.9	01Jul2015, 12:18	0.5
FG24d	0.0262	5.7	01Jul2015, 12:18	0.7
G9b	0.2947	16	01Jul2015, 12:42	4.2
REX RD WQCV	0.2947	16	01Jul2015, 12:48	4.1
G9b-G10	0.2947	16	01Jul2015, 12:48	4.1
FG23b	0.0235	1.1	01Jul2015, 12:18	0.2
G10	1.0326	39	01Jul2015, 12:30	13
G10-G11	1.0326	38	01Jul2015, 12:36	13
FG23c	0.0109	1.0	01Jul2015, 12:12	0.2
G11	1.0435	39	01Jul2015, 12:36	13
FG25	0.1084	22	01Jul2015, 12:18	3.1
FG28	0.0184	1.2	01Jul2015, 12:12	0.2
POND G IN-WEST	1.1703	56	01Jul2015, 12:36	16
FG27	0.0679	24	01Jul2015, 12:24	3.4
FG26	0.0570	5.1	01Jul2015, 12:18	0.9
G13	0.0570	5.1	01Jul2015, 12:18	0.9
G13-POND G	0.0570	5.1	01Jul2015, 12:24	0.9
POND G IN-EAST	0.1249	29	01Jul2015, 12:24	4.3
POND G	1.2952	19	01Jul2015, 16:18	13
G12	1.2952	19	01Jul2015, 16:18	13
G12-G06	1.2952	19	01Jul2015, 16:24	13
FG29	0.0983	2.9	01Jul2015, 12:24	0.9
FG32	0.0402	1.0	01Jul2015, 12:30	0.3
FG32-G06	0.0402	1.0	01Jul2015, 12:36	0.3
G06	1.4337	20	01Jul2015, 16:30	14

INTERIM SCS (2-YEAR)				
HYDROLOGIC ELEMENT	DRAINAGE AREA (SQ. MI.)	PEAK DISCHARGE Q2 (CFS)	TIME OF PEAK	TOTAL VOLUME Q2 (AC. FT.)
OS06	0.1313	0.5	01Jul2015, 13:30	0.3
G1a	0.1313	0.5	01Jul2015, 13:30	0.3
G1a-G2	0.1313	0.5	01Jul2015, 13:48	0.3
OS05	0.0578	0.2	01Jul2015, 13:24	0.2
OS05-G1	0.0578	0.2	01Jul2015, 13:30	0.2
FG01	0.0538	0.9	01Jul2015, 12:48	0.4
FG01-G1	0.0538	0.9	01Jul2015, 12:48	0.4
G1	0.1116	1.1	01Jul2015, 12:54	0.5
G1-G2	0.1116	1.1	01Jul2015, 13:00	0.5
FG02	0.0391	0.5	01Jul2015, 12:30	0.2
G2	0.2820	1.9	01Jul2015, 13:18	1.0
G2-G3	0.2820	1.9	01Jul2015, 13:30	1.0
FG03	0.0203	0.8	01Jul2015, 12:12	0.2
FG04	0.0172	0.9	01Jul2015, 12:06	0.1
G3	0.3195	2.4	01Jul2015, 13:24	1.3
FG06	0.0675	1.3	01Jul2015, 12:24	0.4
FG05	0.0580	2.4	01Jul2015, 12:30	0.6
OS07ab	0.0170	0.1	01Jul2015, 13:18	0.04
OS07ab-POND F	0.0170	0.1	01Jul2015, 14:00	0.04
POND F IN	0.4620	5.1	01Jul2015, 12:42	2.4
POND F	0.4620	2.1	01Jul2015, 17:54	1.6
POND F-G7	0.4620	2.1	01Jul2015, 18:06	1.5
OS07c	0.0158	0.1	01Jul2015, 13:06	0.04
OS07c-G4	0.0158	0.1	01Jul2015, 13:36	0.04
FG21a	0.0095	0.1	01Jul2015, 13:06	0.03
G4	0.0253	0.1	01Jul2015, 13:30	0.1
G4-G7	0.0253	0.1	01Jul2015, 13:36	0.1
FG21b	0.0150	1.7	01Jul2015, 12:12	0.2
G7	0.5023	2.3	01Jul2015, 17:48	1.8
G7-G8	0.5023	2.3	01Jul2015, 17:54	1.8
FG22	0.1400	5.3	01Jul2015, 12:24	1.2
OS08a	0.0469	0.2	01Jul2015, 13:24	0.1
OS08-G8	0.0469	0.2	01Jul2015, 13:30	0.1
FG23a	0.0216	0.8	01Jul2015, 12:18	0.2
OS07d	0.0036	0.0	01Jul2015, 13:18	0.01
OS07d-G8	0.0036	0.0	01Jul2015, 13:36	0.01
G8	0.7144	7.6	01Jul2015, 12:18	3.3
G8-G10	0.7144	7.6	01Jul2015, 12:42	3.2
OS08b	0.1167	1.3	01Jul2015, 12:54	0.6
OS08b-G9a	0.1167	1.2	01Jul2015, 13:18	0.5
FG24b	0.0589	1.4	01Jul2015, 12:36	0.4
FG24a	0.0359	0.3	01Jul2015, 13:00	0.1
OS09a	0.0279	0.2	01Jul2015, 13:12	0.1
OS09a-G9a	0.0279	0.2	01Jul2015, 13:42	0.1
G9a	0.2394	2.6	01Jul2015, 13:12	1.2

Highlighted green rows reference key design points (Typical all charts this section)

INTERIM SCS (2-YEAR)				
HYDROLOGIC ELEMENT	DRAINAGE AREA (SQ. MI.)	PEAK DISCHARGE Q2 (CFS)	TIME OF PEAK	TOTAL VOLUME Q2 (AC. FT.)
G9a-G9b	0.2394	2.6	01Jul2015, 13:18	1.2
FG24c	0.0291	0.8	01Jul2015, 12:24	0.2
FG24d	0.0262	2.6	01Jul2015, 12:18	0.4
G9b	0.2947	4.0	01Jul2015, 12:24	1.8
REX RD WQCV	0.2947	3.8	01Jul2015, 13:12	1.7
G9b-G10	0.2947	3.8	01Jul2015, 13:18	1.7
FG23b	0.0235	0.2	01Jul2015, 13:00	0.1
G10	1.0326	11.0	01Jul2015, 12:42	4.9
G10-G11	1.0326	10.9	01Jul2015, 12:48	4.9
FG23c	0.0109	0.2	01Jul2015, 12:18	0.1
G11	1.0435	11.1	01Jul2015, 12:48	4.9
FG25	0.1084	9.9	01Jul2015, 12:24	1.7
FG28	0.0184	0.2	01Jul2015, 12:36	0.1
POND G IN-WEST	1.1703	17.2	01Jul2015, 12:48	6.7
FG27	0.0679	14.2	01Jul2015, 12:24	2.2
FG26	0.0570	1.3	01Jul2015, 12:30	0.4
G13	0.0570	1.3	01Jul2015, 12:30	0.4
G13-POND G	0.0570	1.3	01Jul2015, 12:36	0.4
POND G IN-EAST	0.1249	15.5	01Jul2015, 12:30	2.6
POND G	1.2952	5.0	02Jul2015, 00:00	4.2
G12	1.2952	5.0	02Jul2015, 00:00	4.2
G12-G06	1.2952	5.0	02Jul2015, 00:00	4.1
FG29	0.0983	0.4	01Jul2015, 13:30	0.3
FG32	0.0402	0.2	01Jul2015, 13:42	0.1
FG32-G06	0.0402	0.2	01Jul2015, 13:48	0.1
G06	1.4337	5.3	01Jul2015, 23:48	4.4

Highlighted green rows reference key design points (Typical all charts this section)

FUTURE SCS (100-YEAR)				
HYDROLOGIC ELEMENT	DRAINAGE AREA (SQ. MI.)	PEAK DISCHARGE Q100 (CFS)	TIME OF PEAK	TOTAL VOLUME Q100 (AC. FT.)
OS06	0.1313	80	01Jul2015, 12:12	9.3
G1a	0.1313	80	01Jul2015, 12:12	9.3
G1a-G2	0.1313	79	01Jul2015, 12:18	9.2
OS05	0.0578	39	01Jul2015, 12:12	4.1
OS05-G1	0.0578	39	01Jul2015, 12:12	4.1
FG01	0.0538	31	01Jul2015, 12:30	4.9
FG01-G1	0.0538	31	01Jul2015, 12:30	4.9
G1	0.1116	61	01Jul2015, 12:18	9.0
G1-G2	0.1116	61	01Jul2015, 12:18	9.0
FG02	0.0391	32	01Jul2015, 12:12	3.3
G2	0.2820	167	01Jul2015, 12:18	21
G2-G3	0.2820	163	01Jul2015, 12:18	21
FG03	0.0203	24	01Jul2015, 12:06	2.0
FG04	0.0172	22	01Jul2015, 12:00	1.7
G3	0.3195	185	01Jul2015, 12:18	25
FG06	0.0675	56	01Jul2015, 12:12	6.1
FG05	0.0580	45	01Jul2015, 12:24	6.1
OS07ab	0.0170	12	01Jul2015, 12:06	1.2
OS07ab-POND F	0.0170	12	01Jul2015, 12:18	1.2
POND F IN	0.4620	293	01Jul2015, 12:18	38
POND F	0.4620	178	01Jul2015, 12:42	36
POND F-G7	0.4620	177	01Jul2015, 12:42	36
OS07c	0.0296	19	01Jul2015, 12:12	2.1
OS07c-G4	0.0296	19	01Jul2015, 12:18	2.1
FG21a	0.0095	5.9	01Jul2015, 12:18	0.7
G4	0.0391	25	01Jul2015, 12:18	2.8
G4-G7	0.0391	24	01Jul2015, 12:18	2.8
FG21b	0.0150	21	01Jul2015, 12:06	1.8
G7	0.5161	194	01Jul2015, 12:42	40
G7-G8	0.5161	194	01Jul2015, 12:42	40
FG22	0.1354	121	01Jul2015, 12:12	14
OS08a	0.0251	16	01Jul2015, 12:12	1.8
OS08-G8	0.0251	16	01Jul2015, 12:18	1.8
FG23a	0.0216	21	01Jul2015, 12:12	2.2
OS07d	0.0034	2.5	01Jul2015, 12:06	0.2
OS07d-G8	0.0034	2.4	01Jul2015, 12:12	0.2
G8	0.7016	279	01Jul2015, 12:30	58
G8-G10	0.7016	278	01Jul2015, 12:36	58
FG24b	0.0589	76	01Jul2015, 12:06	7.1
FG24a	0.0348	24	01Jul2015, 12:18	2.9
OS08b	0.0165	9.5	01Jul2015, 12:18	1.2
OS08b-G9a	0.0165	9.4	01Jul2015, 12:30	1.1
OS09a	0.0093	5.3	01Jul2015, 12:18	0.7
OS09a-G9a	0.0093	5.2	01Jul2015, 12:30	0.6
G9a	0.1195	97	01Jul2015, 12:12	12

Highlighted green rows reference key design points (Typical all charts this section)

FUTURE SCS (100-YEAR)				
HYDROLOGIC ELEMENT	DRAINAGE AREA (SQ. MI.)	PEAK DISCHARGE Q100 (CFS)	TIME OF PEAK	TOTAL VOLUME Q100 (AC. FT.)
G9a-G9b	0.1195	96	01Jul2015, 12:12	12
FG24c	0.0291	40	01Jul2015, 12:06	3.7
FG24d	0.0262	39	01Jul2015, 12:06	3.5
G9b	0.1748	170	01Jul2015, 12:12	19
REX RD WQCV	0.1748	158	01Jul2015, 12:18	19
G9b-G10	0.1748	158	01Jul2015, 12:18	19
FG23b	0.0236	17	01Jul2015, 12:12	1.7
G10	0.9000	390	01Jul2015, 12:24	78
G10-G11	0.9000	389	01Jul2015, 12:30	78
FG23c	0.0109	11	01Jul2015, 12:06	1.0
G11	0.9109	393	01Jul2015, 12:30	79
FG25	0.1084	111	01Jul2015, 12:18	13
FG28	0.0184	15	01Jul2015, 12:12	1.5
POND G IN-W	1.0377	503	01Jul2015, 12:24	94
FG27	0.0679	98	01Jul2015, 12:12	11
FG26	0.0570	65	01Jul2015, 12:18	8.0
G13	0.0570	65	01Jul2015, 12:18	8.0
G13-POND G	0.0570	64	01Jul2015, 12:24	8.0
POND G IN-E	0.1249	160	01Jul2015, 12:18	19
POND G	1.1626	450	01Jul2015, 12:48	103
G12	1.1626	450	01Jul2015, 12:48	103
G12-G06	1.1626	449	01Jul2015, 12:54	102
FG29	0.0983	60	01Jul2015, 12:12	7.0
FG32	0.0402	51	01Jul2015, 12:18	6.1
FG32-G06	0.0402	50	01Jul2015, 12:18	6.1
G06	1.3011	491	01Jul2015, 12:48	115

Highlighted green rows reference key design points (Typical all charts this section)

GIECK FUTURE CONDITIONS

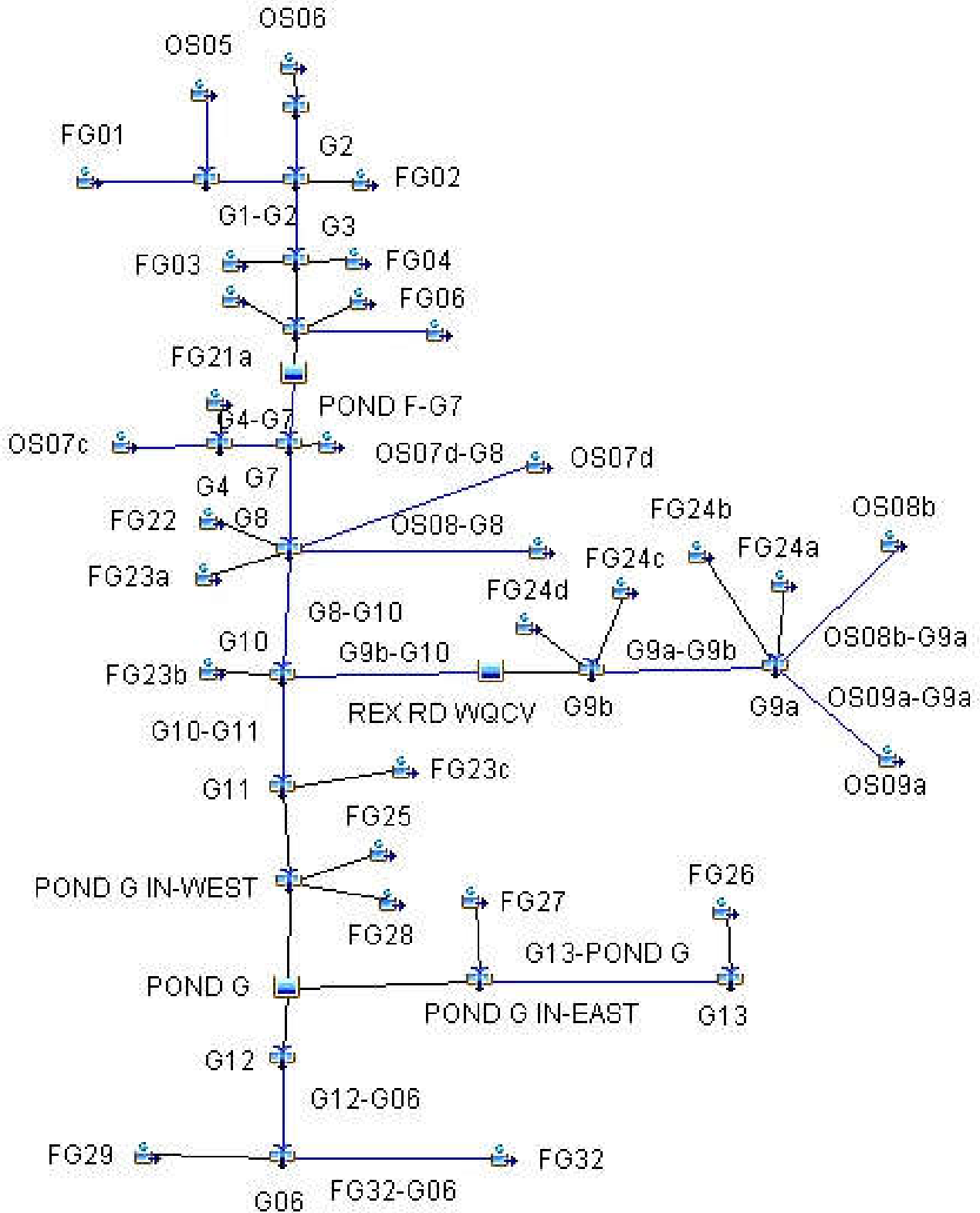

FUTURE SCS (50-YEAR)				
HYDROLOGIC ELEMENT	DRAINAGE AREA (SQ. MI.)	PEAK DISCHARGE Q50 (CFS)	TIME OF PEAK	TOTAL VOLUME Q50 (AC. FT.)
OS06	0.1313	52	01Jul2015, 12:12	6.5
G1a	0.1313	52	01Jul2015, 12:12	6.5
G1a-G2	0.1313	52	01Jul2015, 12:18	6.5
OS05	0.0578	26	01Jul2015, 12:12	2.9
OS05-G1	0.0578	25	01Jul2015, 12:12	2.9
FG01	0.0538	22	01Jul2015, 12:30	3.6
FG01-G1	0.0538	22	01Jul2015, 12:30	3.6
G1	0.1116	41	01Jul2015, 12:18	6.4
G1-G2	0.1116	41	01Jul2015, 12:18	6.4
FG02	0.0391	22	01Jul2015, 12:12	2.4
G2	0.2820	112	01Jul2015, 12:18	15
G2-G3	0.2820	108	01Jul2015, 12:24	15
FG03	0.0203	17	01Jul2015, 12:06	1.5
FG04	0.0172	16	01Jul2015, 12:00	1.3
G3	0.3195	123	01Jul2015, 12:18	18
FG06	0.0675	40	01Jul2015, 12:12	4.4
FG05	0.0580	33	01Jul2015, 12:24	4.6
OS07ab	0.0170	7.9	01Jul2015, 12:12	0.9
OS07ab-POND F	0.0170	7.6	01Jul2015, 12:18	0.8
POND F IN	0.4620	200	01Jul2015, 12:18	28
POND F	0.4620	121	01Jul2015, 12:42	26
POND F-G7	0.4620	120	01Jul2015, 12:48	26
OS07c	0.0296	12	01Jul2015, 12:12	1.5
OS07c-G4	0.0296	12	01Jul2015, 12:18	1.5
FG21a	0.0095	4.0	01Jul2015, 12:18	0.5
G4	0.0391	16	01Jul2015, 12:18	2.0
G4-G7	0.0391	16	01Jul2015, 12:24	2.0
FG21b	0.0150	16	01Jul2015, 12:06	1.4
G7	0.5161	131	01Jul2015, 12:48	29
G7-G8	0.5161	131	01Jul2015, 12:48	29
FG22	0.1354	88	01Jul2015, 12:12	10
OS08a	0.0251	11	01Jul2015, 12:12	1.3
OS08-G8	0.0251	10	01Jul2015, 12:18	1.2
FG23a	0.0216	15	01Jul2015, 12:12	1.6
OS07d	0.0034	1.6	01Jul2015, 12:06	0.2
OS07d-G8	0.0034	1.6	01Jul2015, 12:18	0.2
G8	0.7016	178	01Jul2015, 12:42	42
G8-G10	0.7016	177	01Jul2015, 12:48	42
FG24b	0.0589	57	01Jul2015, 12:06	5.4
FG24a	0.0348	16	01Jul2015, 12:18	2.1
OS08b	0.0165	6.3	01Jul2015, 12:18	0.8
OS08b-G9a	0.0165	6.0	01Jul2015, 12:36	0.8
OS09a	0.0093	3.5	01Jul2015, 12:18	0.5
OS09a-G9a	0.0093	3.4	01Jul2015, 12:30	0.5
G9a	0.1195	71	01Jul2015, 12:12	8.8

Highlighted green rows reference key design points (Typical all charts this section)

FUTURE SCS (50-YEAR)				
HYDROLOGIC ELEMENT	DRAINAGE AREA (SQ. MI.)	PEAK DISCHARGE Q50 (CFS)	TIME OF PEAK	TOTAL VOLUME Q50 (AC. FT.)
G9a-G9b	0.1195	70	01Jul2015, 12:12	8.7
FG24c	0.0291	30	01Jul2015, 12:06	2.9
FG24d	0.0262	30	01Jul2015, 12:06	2.7
G9b	0.1748	127	01Jul2015, 12:12	14
REX RD WQCV	0.1748	125	01Jul2015, 12:12	14
G9b-G10	0.1748	123	01Jul2015, 12:12	14
FG23b	0.0236	11	01Jul2015, 12:12	1.2
G10	0.9000	263	01Jul2015, 12:18	57
G10-G11	0.9000	254	01Jul2015, 12:24	57
FG23c	0.0109	7.6	01Jul2015, 12:06	0.7
G11	0.9109	258	01Jul2015, 12:24	57
FG25	0.1084	84	01Jul2015, 12:18	10
FG28	0.0184	10	01Jul2015, 12:12	1.1
POND G IN-WEST	1.0377	350	01Jul2015, 12:18	69
FG27	0.0679	79	01Jul2015, 12:12	9.1
FG26	0.0570	50	01Jul2015, 12:18	6.3
G13	0.0570	50	01Jul2015, 12:18	6.3
G13-POND G	0.0570	50	01Jul2015, 12:24	6.3
POND G IN-EAST	0.1249	127	01Jul2015, 12:18	15
POND G	1.1626	293	01Jul2015, 12:54	75
G12	1.1626	293	01Jul2015, 12:54	75
G12-G06	1.1626	293	01Jul2015, 13:00	74
FG29	0.0983	39	01Jul2015, 12:18	5.0
FG32	0.0402	40	01Jul2015, 12:18	4.8
FG32-G06	0.0402	40	01Jul2015, 12:18	4.8
G06	1.3011	317	01Jul2015, 13:00	84

Highlighted green rows reference key design points (Typical all charts this section)

FUTURE SCS (10-YEAR)				
HYDROLOGIC ELEMENT	DRAINAGE AREA (SQ. MI.)	PEAK DISCHARGE Q10 (CFS)	TIME OF PEAK	TOTAL VOLUME Q10 (AC. FT.)
OS06	0.1313	12	01Jul2015, 12:18	2.2
G1a	0.1313	12	01Jul2015, 12:18	2.2
G1a-G2	0.1313	11	01Jul2015, 12:24	2.1
OS05	0.0578	5.6	01Jul2015, 12:12	1.0
OS05-G1	0.0578	5.5	01Jul2015, 12:18	1.0
FG01	0.0538	7.0	01Jul2015, 12:36	1.4
FG01-G1	0.0538	7.0	01Jul2015, 12:36	1.4
G1	0.1116	11	01Jul2015, 12:24	2.3
G1-G2	0.1116	11	01Jul2015, 12:30	2.3
FG02	0.0391	6.4	01Jul2015, 12:12	0.9
G2	0.2820	27	01Jul2015, 12:24	5.4
G2-G3	0.2820	27	01Jul2015, 12:30	5.3
FG03	0.0203	5.9	01Jul2015, 12:06	0.6
FG04	0.0172	5.8	01Jul2015, 12:06	0.5
G3	0.3195	31	01Jul2015, 12:30	6.4
FG06	0.0675	12	01Jul2015, 12:18	1.7
FG05	0.0580	12	01Jul2015, 12:24	2.0
OS07ab	0.0170	1.8	01Jul2015, 12:12	0.3
OS07ab-POND F	0.0170	1.7	01Jul2015, 12:30	0.3
POND F IN	0.4620	54	01Jul2015, 12:24	10
POND F	0.4620	16	01Jul2015, 13:48	9.1
POND F-G7	0.4620	16	01Jul2015, 13:54	9.0
OS07c	0.0296	2.7	01Jul2015, 12:18	0.5
OS07c-G4	0.0296	2.6	01Jul2015, 12:30	0.5
FG21a	0.0095	1.0	01Jul2015, 12:24	0.2
G4	0.0391	3.6	01Jul2015, 12:24	0.7
G4-G7	0.0391	3.5	01Jul2015, 12:30	0.7
FG21b	0.0150	6.5	01Jul2015, 12:06	0.6
G7	0.5161	18	01Jul2015, 13:36	10
G7-G8	0.5161	18	01Jul2015, 13:42	10
FG22	0.1354	32	01Jul2015, 12:18	4.3
OS08a	0.0251	2.3	01Jul2015, 12:18	0.4
OS08-G8	0.0251	2.3	01Jul2015, 12:24	0.4
FG23a	0.0216	5.2	01Jul2015, 12:12	0.7
OS07d	0.0034	0.4	01Jul2015, 12:12	0.1
OS07d-G8	0.0034	0.3	01Jul2015, 12:24	0.1
G8	0.7016	46	01Jul2015, 12:18	16
G8-G10	0.7016	45	01Jul2015, 12:24	15
FG24b	0.0589	24	01Jul2015, 12:12	2.5
FG24a	0.0348	4.5	01Jul2015, 12:18	0.8
OS08b	0.0165	1.4	01Jul2015, 12:18	0.3
OS08b-G9a	0.0165	1.4	01Jul2015, 12:42	0.3
OS09a	0.0093	0.8	01Jul2015, 12:24	0.2
OS09a-G9a	0.0093	0.7	01Jul2015, 12:42	0.2
G9a	0.1195	28	01Jul2015, 12:12	3.7

Highlighted green rows reference key design points (Typical all charts this section)

FUTURE SCS (10-YEAR)				
HYDROLOGIC ELEMENT	DRAINAGE AREA (SQ. MI.)	PEAK DISCHARGE Q10 (CFS)	TIME OF PEAK	TOTAL VOLUME Q10 (AC. FT.)
G9a-G9b	0.1195	27	01Jul2015, 12:12	3.6
FG24c	0.0291	13	01Jul2015, 12:12	1.3
FG24d	0.0262	14	01Jul2015, 12:06	1.3
G9b	0.1748	53	01Jul2015, 12:12	6.3
REX RD WQCV	0.1748	51	01Jul2015, 12:12	6.1
G9b-G10	0.1748	50	01Jul2015, 12:18	6.1
FG23b	0.0236	2.7	01Jul2015, 12:12	0.4
G10	0.9000	90	01Jul2015, 12:24	22
G10-G11	0.9000	85	01Jul2015, 12:30	22
FG23c	0.0109	2.2	01Jul2015, 12:06	0.3
G11	0.9109	86	01Jul2015, 12:30	22
FG25	0.1084	36	01Jul2015, 12:18	4.7
FG28	0.0184	3.0	01Jul2015, 12:12	0.4
POND G IN-WEST	1.0377	122	01Jul2015, 12:24	27
FG27	0.0679	42	01Jul2015, 12:18	4.9
FG26	0.0570	24	01Jul2015, 12:18	3.1
G13	0.0570	24	01Jul2015, 12:18	3.1
G13-POND G	0.0570	24	01Jul2015, 12:24	3.1
POND G IN-EAST	0.1249	64	01Jul2015, 12:18	8.0
POND G	1.1626	52	01Jul2015, 13:48	27
G12	1.1626	52	01Jul2015, 13:48	27
G12-G06	1.1626	52	01Jul2015, 13:54	27
FG29	0.0983	8.9	01Jul2015, 12:18	1.7
FG32	0.0402	20	01Jul2015, 12:18	2.4
FG32-G06	0.0402	19	01Jul2015, 12:18	2.4
G06	1.3011	57	01Jul2015, 13:48	31

Highlighted green rows reference key design points (Typical all charts this section)

FUTURE SCS (5-YEAR)				
HYDROLOGIC ELEMENT	DRAINAGE AREA (SQ. MI.)	PEAK DISCHARGE Q5 (CFS)	TIME OF PEAK	TOTAL VOLUME Q5 (AC. FT.)
OS06	0.1313	3.8	01Jul2015, 12:24	1.1
G1a	0.1313	3.8	01Jul2015, 12:24	1.1
G1a-G2	0.1313	3.7	01Jul2015, 12:30	1.1
OS05	0.0578	1.8	01Jul2015, 12:18	0.5
OS05-G1	0.0578	1.7	01Jul2015, 12:24	0.5
FG01	0.0538	3.4	01Jul2015, 12:36	0.8
FG01-G1	0.0538	3.4	01Jul2015, 12:36	0.8
G1	0.1116	4.9	01Jul2015, 12:36	1.3
G1-G2	0.1116	4.8	01Jul2015, 12:36	1.3
FG02	0.0391	2.7	01Jul2015, 12:18	0.5
G2	0.2820	10	01Jul2015, 12:30	2.9
G2-G3	0.2820	10	01Jul2015, 12:42	2.9
FG03	0.0203	3.0	01Jul2015, 12:06	0.4
FG04	0.0172	3.1	01Jul2015, 12:06	0.3
G3	0.3195	12	01Jul2015, 12:36	3.5
FG06	0.0675	5.8	01Jul2015, 12:18	1.0
FG05	0.0580	6.7	01Jul2015, 12:30	1.2
OS07ab	0.0170	0.5	01Jul2015, 12:18	0.2
OS07ab-POND F	0.0170	0.5	01Jul2015, 12:42	0.1
POND F IN	0.4620	23	01Jul2015, 12:36	5.9
POND F	0.4620	8.0	01Jul2015, 14:12	4.8
POND F-G7	0.4620	8.0	01Jul2015, 14:24	4.8
OS07c	0.0296	0.9	01Jul2015, 12:24	0.3
OS07c-G4	0.0296	0.9	01Jul2015, 12:36	0.3
FG21a	0.0095	0.4	01Jul2015, 12:24	0.1
G4	0.0391	1.2	01Jul2015, 12:36	0.3
G4-G7	0.0391	1.2	01Jul2015, 12:36	0.3
FG21b	0.0150	3.9	01Jul2015, 12:06	0.4
G7	0.5161	8.9	01Jul2015, 14:12	5.5
G7-G8	0.5161	8.9	01Jul2015, 14:18	5.5
FG22	0.1354	17	01Jul2015, 12:18	2.6
OS08a	0.0251	0.7	01Jul2015, 12:24	0.2
OS08-G8	0.0251	0.7	01Jul2015, 12:30	0.2
FG23a	0.0216	2.7	01Jul2015, 12:18	0.4
OS07d	0.0034	0.1	01Jul2015, 12:18	0.0
OS07d-G8	0.0034	0.1	01Jul2015, 12:30	0.0
G8	0.7016	24	01Jul2015, 12:18	8.7
G8-G10	0.7016	24	01Jul2015, 12:30	8.5
FG24b	0.0589	15	01Jul2015, 12:12	1.6
FG24a	0.0348	2.0	01Jul2015, 12:24	0.4
OS08b	0.0165	0.5	01Jul2015, 12:24	0.1
OS08b-G9a	0.0165	0.5	01Jul2015, 13:00	0.1
OS09a	0.0093	0.3	01Jul2015, 12:30	0.1
OS09a-G9a	0.0093	0.3	01Jul2015, 13:00	0.1
G9a	0.1195	16	01Jul2015, 12:12	2.3

Highlighted green rows reference key design points (Typical all charts this section)

FUTURE SCS (5-YEAR)				
HYDROLOGIC ELEMENT	DRAINAGE AREA (SQ. MI.)	PEAK DISCHARGE Q5 (CFS)	TIME OF PEAK	TOTAL VOLUME Q5 (AC. FT.)
G9a-G9b	0.1195	16	01Jul2015, 12:18	2.2
FG24c	0.0291	8.4	01Jul2015, 12:12	0.9
FG24d	0.0262	8.7	01Jul2015, 12:06	0.9
G9b	0.1748	32	01Jul2015, 12:12	4.0
REX RD WQCV	0.1748	31	01Jul2015, 12:18	3.9
G9b-G10	0.1748	31	01Jul2015, 12:18	3.9
FG23b	0.0236	0.9	01Jul2015, 12:18	0.2
G10	0.9000	46	01Jul2015, 12:30	13
G10-G11	0.9000	44	01Jul2015, 12:36	12
FG23c	0.0109	1.0	01Jul2015, 12:12	0.2
G11	0.9109	44	01Jul2015, 12:36	13
FG25	0.1084	22	01Jul2015, 12:18	3.1
FG28	0.0184	1.2	01Jul2015, 12:12	0.2
POND G IN-WEST	1.0377	63	01Jul2015, 12:30	16
FG27	0.0679	30	01Jul2015, 12:18	3.5
FG26	0.0570	16	01Jul2015, 12:18	2.1
G13	0.0570	16	01Jul2015, 12:18	2.1
G13-POND G	0.0570	16	01Jul2015, 12:24	2.1
POND G IN-EAST	0.1249	44	01Jul2015, 12:18	5.7
POND G	1.1626	21	01Jul2015, 15:24	14
G12	1.1626	21	01Jul2015, 15:24	14
G12-G06	1.1626	21	01Jul2015, 15:36	14
FG29	0.0983	2.9	01Jul2015, 12:24	0.9
FG32	0.0402	14	01Jul2015, 12:18	1.7
FG32-G06	0.0402	13	01Jul2015, 12:24	1.7
G06	1.3011	22	01Jul2015, 15:30	17

Highlighted green rows reference key design points (Typical all charts this section)

FUTURE SCS (2-YEAR)				
HYDROLOGIC ELEMENT	DRAINAGE AREA (SQ. MI.)	PEAK DISCHARGE Q2 (CFS)	TIME OF PEAK	TOTAL VOLUME Q2 (AC. FT.)
OS06	0.1313	0.5	01Jul2015, 13:30	0.34
G1a	0.1313	0.5	01Jul2015, 13:30	0.34
G1a-G2	0.1313	0.5	01Jul2015, 13:48	0.33
OS05	0.0578	0.2	01Jul2015, 13:24	0.15
OS05-G1	0.0578	0.2	01Jul2015, 13:30	0.15
FG01	0.0538	0.9	01Jul2015, 12:48	0.35
FG01-G1	0.0538	0.9	01Jul2015, 12:48	0.35
G1	0.1116	1.1	01Jul2015, 12:54	0.50
G1-G2	0.1116	1.1	01Jul2015, 13:00	0.49
FG02	0.0391	0.5	01Jul2015, 12:30	0.20
G2	0.2820	1.9	01Jul2015, 13:18	1.02
G2-G3	0.2820	1.9	01Jul2015, 13:30	1.00
FG03	0.0203	0.8	01Jul2015, 12:12	0.16
FG04	0.0172	0.9	01Jul2015, 12:06	0.14
G3	0.3195	2.4	01Jul2015, 13:24	1.30
FG06	0.0675	1.3	01Jul2015, 12:24	0.42
FG05	0.0580	2.4	01Jul2015, 12:30	0.59
OS07ab	0.0170	0.1	01Jul2015, 13:18	0.04
OS07ab-POND F	0.0170	0.1	01Jul2015, 14:00	0.04
POND F IN	0.4620	5.1	01Jul2015, 12:42	2.36
POND F	0.4620	2.1	01Jul2015, 17:54	1.55
POND F-G7	0.4620	2.1	01Jul2015, 18:06	1.50
OS07c	0.0296	0.1	01Jul2015, 13:30	0.08
OS07c-G4	0.0296	0.1	01Jul2015, 13:54	0.07
FG21a	0.0095	0.1	01Jul2015, 13:06	0.03
G4	0.0391	0.2	01Jul2015, 13:42	0.11
G4-G7	0.0391	0.2	01Jul2015, 13:42	0.11
FG21b	0.0150	1.7	01Jul2015, 12:12	0.21
G7	0.5161	2.3	01Jul2015, 17:48	1.82
G7-G8	0.5161	2.3	01Jul2015, 17:54	1.79
FG22	0.1354	5.4	01Jul2015, 12:24	1.23
OS08a	0.0251	0.1	01Jul2015, 13:30	0.07
OS08-G8	0.0251	0.1	01Jul2015, 13:36	0.06
FG23a	0.0216	0.8	01Jul2015, 12:18	0.19
OS07d	0.0034	0.01	01Jul2015, 13:18	0.01
OS07d-G8	0.0034	0.01	01Jul2015, 13:36	0.01
G8	0.7016	7.7	01Jul2015, 12:18	3.28
G8-G10	0.7016	7.6	01Jul2015, 12:42	3.14
FG24b	0.0589	6.5	01Jul2015, 12:12	0.86
FG24a	0.0348	0.4	01Jul2015, 12:48	0.17
OS08b	0.0165	0.1	01Jul2015, 13:36	0.04
OS08b-G9a	0.0165	0.1	01Jul2015, 14:30	0.04
OS09a	0.0093	0.04	01Jul2015, 13:36	0.02
OS09a-G9a	0.0093	0.04	01Jul2015, 14:24	0.02
G9a	0.1195	6.7	01Jul2015, 12:12	1.08

Highlighted green rows reference key design points (Typical all charts this section)

FUTURE SCS (2-YEAR)				
HYDROLOGIC ELEMENT	DRAINAGE AREA (SQ. MI.)	PEAK DISCHARGE Q2 (CFS)	TIME OF PEAK	TOTAL VOLUME Q2 (AC. FT.)
G9a-G9b	0.1195	6.6	01Jul2015, 12:18	1.1
FG24c	0.0291	4.0	01Jul2015, 12:12	0.5
FG24d	0.0262	4.4	01Jul2015, 12:12	0.5
G9b	0.1748	14	01Jul2015, 12:12	2.1
REX RD WQCV	0.1748	14	01Jul2015, 12:18	1.9
G9b-G10	0.1748	13	01Jul2015, 12:24	1.9
FG23b	0.0236	0.1	01Jul2015, 13:06	0.1
G10	0.9000	15	01Jul2015, 12:42	5.2
G10-G11	0.9000	15	01Jul2015, 12:48	5.1
FG23c	0.0109	0.2	01Jul2015, 12:18	0.1
G11	0.9109	15	01Jul2015, 12:48	5.2
FG25	0.1084	10	01Jul2015, 12:24	1.7
FG28	0.0184	0.2	01Jul2015, 12:36	0.1
POND G IN-WEST	1.0377	22	01Jul2015, 12:24	6.9
FG27	0.0679	18	01Jul2015, 12:18	2.2
FG26	0.0570	8.2	01Jul2015, 12:24	1.2
G13	0.0570	8.2	01Jul2015, 12:24	1.2
G13-POND G	0.0570	8.1	01Jul2015, 12:24	1.2
POND G IN-EAST	0.1249	25	01Jul2015, 12:18	3.5
POND G	1.1626	5.3	02Jul2015, 00:00	4.7
G12	1.1626	5.3	02Jul2015, 00:00	4.7
G12-G06	1.1626	5.3	02Jul2015, 00:00	4.5
FG29	0.0983	0.4	01Jul2015, 13:30	0.3
FG32	0.0402	7.5	01Jul2015, 12:18	1.0
FG32-G06	0.0402	7.4	01Jul2015, 12:24	1.0
G06	1.3011	7.5	01Jul2015, 12:24	5.8

Highlighted green rows reference key design points (Typical all charts this section)

Appendix B – Rational Calculations

Table 6-6. Runoff Coefficients for Rational Method
(Source: UDFCD 2001)

Land Use or Surface Characteristics	Percent Impervious	Runoff Coefficients											
		2-year		5-year		10-year		25-year		50-year		100-year	
		HSG A&B	HSG C&D	HSG A&B	HSG C&D	HSG A&B	HSG C&D	HSG A&B	HSG C&D	HSG A&B	HSG C&D	HSG A&B	HSG C&D
Business													
Commercial Areas	95	0.79	0.80	0.81	0.82	0.83	0.84	0.85	0.87	0.87	0.88	0.88	0.89
Neighborhood Areas	70	0.45	0.49	0.49	0.53	0.53	0.57	0.58	0.62	0.60	0.65	0.62	0.68
Residential													
1/8 Acre or less	65	0.41	0.45	0.45	0.49	0.49	0.54	0.54	0.59	0.57	0.62	0.59	0.65
1/4 Acre	40	0.23	0.28	0.30	0.35	0.36	0.42	0.42	0.50	0.46	0.54	0.50	0.58
1/3 Acre	30	0.18	0.22	0.25	0.30	0.32	0.38	0.39	0.47	0.43	0.52	0.47	0.57
1/2 Acre	25	0.15	0.20	0.22	0.28	0.30	0.36	0.37	0.46	0.41	0.51	0.46	0.56
1 Acre	20	0.12	0.17	0.20	0.26	0.27	0.34	0.35	0.44	0.40	0.50	0.44	0.55
Industrial													
Light Areas	80	0.57	0.60	0.59	0.63	0.63	0.66	0.66	0.70	0.68	0.72	0.70	0.74
Heavy Areas	90	0.71	0.73	0.73	0.75	0.75	0.77	0.78	0.80	0.80	0.82	0.81	0.83
Parks and Cemeteries													
Parks and Cemeteries	7	0.05	0.09	0.12	0.19	0.20	0.29	0.30	0.40	0.34	0.46	0.39	0.52
Playgrounds	13	0.07	0.13	0.16	0.23	0.24	0.31	0.32	0.42	0.37	0.48	0.41	0.54
Railroad Yard Areas	40	0.23	0.28	0.30	0.35	0.36	0.42	0.42	0.50	0.46	0.54	0.50	0.58
Undeveloped Areas													
Historic Flow Analysis-- Greenbelts, Agriculture	2	0.03	0.05	0.09	0.16	0.17	0.26	0.26	0.38	0.31	0.45	0.36	0.51
Pasture/Meadow	0	0.02	0.04	0.08	0.15	0.15	0.25	0.25	0.37	0.30	0.44	0.35	0.50
Forest	0	0.02	0.04	0.08	0.15	0.15	0.25	0.25	0.37	0.30	0.44	0.35	0.50
Exposed Rock	100	0.89	0.89	0.90	0.90	0.92	0.92	0.94	0.94	0.95	0.95	0.96	0.96
Offsite Flow Analysis (when landuse is undefined)	45	0.26	0.31	0.32	0.37	0.38	0.44	0.44	0.51	0.48	0.55	0.51	0.59
Streets													
Paved	100	0.89	0.89	0.90	0.90	0.92	0.92	0.94	0.94	0.95	0.95	0.96	0.96
Gravel	80	0.57	0.60	0.59	0.63	0.63	0.66	0.66	0.70	0.68	0.72	0.70	0.74
Drive and Walks													
Drive and Walks	100	0.89	0.89	0.90	0.90	0.92	0.92	0.94	0.94	0.95	0.95	0.96	0.96
Roofs	90	0.71	0.73	0.73	0.75	0.75	0.77	0.78	0.80	0.80	0.82	0.81	0.83
Lawns	0	0.02	0.04	0.08	0.15	0.15	0.25	0.25	0.37	0.30	0.44	0.35	0.50

Figure 6-5. Colorado Springs Rainfall Intensity Duration Frequency

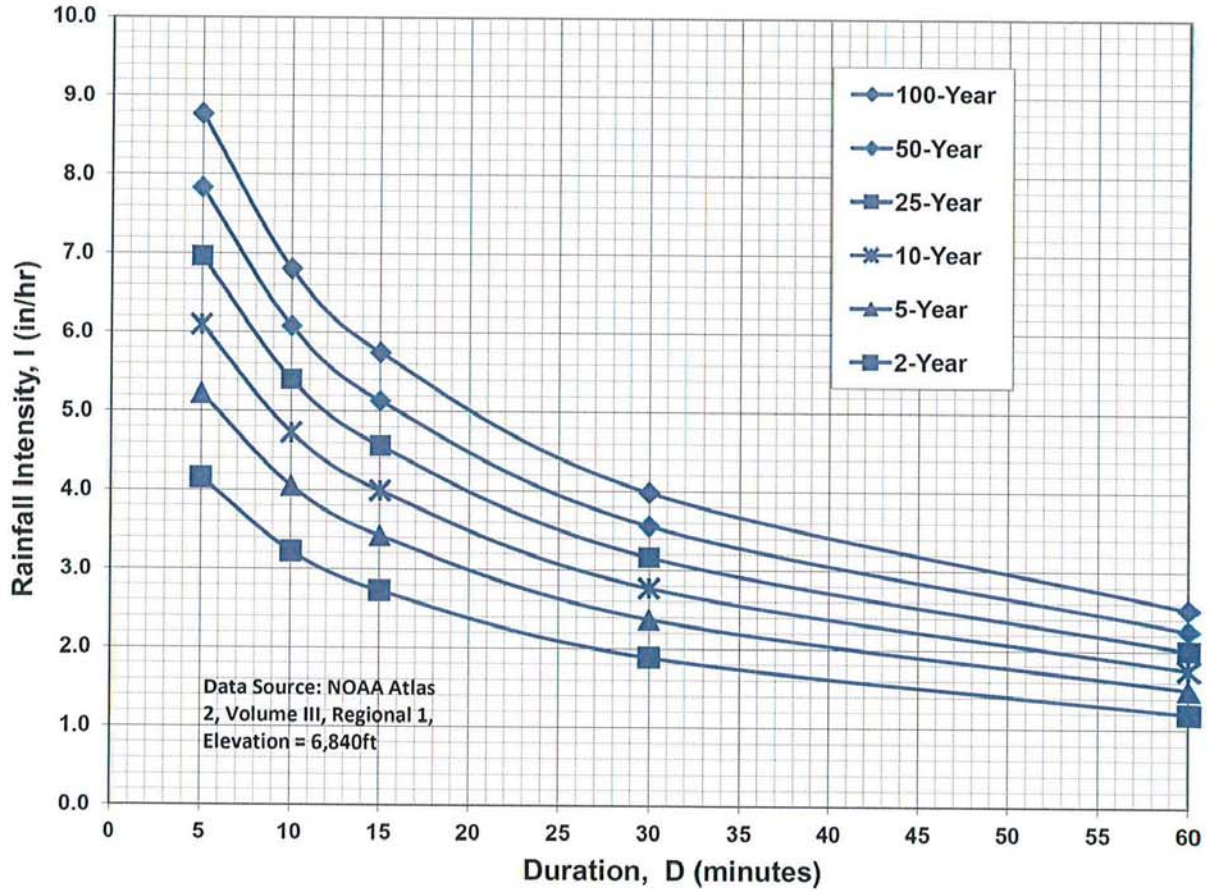

IDF Equations

$$I_{100} = -2.52 \ln(D) + 12.735$$

$$I_{50} = -2.25 \ln(D) + 11.375$$

$$I_{25} = -2.00 \ln(D) + 10.111$$

$$I_{10} = -1.75 \ln(D) + 8.847$$

$$I_5 = -1.50 \ln(D) + 7.583$$

$$I_2 = -1.19 \ln(D) + 6.035$$

Note: Values calculated by equations may not precisely duplicate values read from figure.

COMPOSITE 'C' FACTORS

PROJECT: **The Sanctuary PDR-FDR**

4/27/2022

BASIN DESIGNATION	AREA (AC.)									COMPOSITE FACTOR		Percent Impervious
	UNDEV	2 DU/AC	4 DU/AC	5 DU/AC	6 DU/AC	8 DU/AC	STREETS	OPEN SPACE PARKS/GC LAWNS	TOTAL	5-year	100-year	
OS01				27					27	0.37	0.47	43.0%
OS02				3.0					3.0	0.40	1.10	43.0%
OS03				6.6					6.6	0.35	0.53	43.0%
OS04	37.5	2.7	37.5	8.1			0.8	0.1	102	0.22	0.45	23.7%
A01	0.6		1.7				1.2	1.8	5.3	0.39	0.55	35.4%
A02						4.3			4.3	0.45	0.59	65.0%
A03						5.5			5.5	0.45	0.59	65.0%
A04						4.7			4.7	0.45	0.59	65.0%
A05						2.0	0.5		2.5	0.54	0.67	72.3%
A06						4.5			4.5	0.45	0.59	65.0%
A07						3.6			3.6	0.45	0.59	65.0%
A08						3.3			3.3	0.45	0.59	65.0%
A09						5.0		0.3	5.3	0.44	0.58	61.4%
A10						1.2		0.8	2.0	0.37	0.52	39.5%
A11						0.6		1.2	1.8	0.31	0.47	23.3%
A12	2.3	0.0	2.8	0.0			4.0	0.8	9.9	0.49	0.65	51.9%
										Composite:		36.6%
TOTAL	40.4	2.7	42.0	44.3	0.0	34.7	6.5	4.9	190.8	0.31	0.50	36.6%

TIME OF CONCENTRATION

PROJECT: **The Sanctuary PDR-FDR**

DATE: 4/27/2022

TIME OF CONCENTRATION																				
SUBBASIN DATA			INIT./OVERLAND TIME (T _i)				TRAVEL TIME (T _t)							TOTAL	T _c Check (Urbanized Basins)		FINAL			
BASIN DESIGNATION	C _s	AREA (AC)	LENGTH (FT)	ΔH	SLOPE %	T _i (Min.)*	LENGTH (FT)	ΔH	SLOPE %	CONVEYANCE		VEL. (FPS)	T _t (Min.)**	T _i +T _t (Min.)	L (FT)	T _c = (L/180) + 10	T _c (min)			
										TYPE	COEF.									
OS01	0.37	27	FROM ROLLING HILLS RANCH NORTH RATIONAL CALCULATIONS																	22.9
OS02	0.40	3	FROM ROLLING HILLS RANCH NORTH RATIONAL CALCULATIONS																	15.7
OS03	0.35	7	FROM ROLLING HILLS RANCH NORTH RATIONAL CALCULATIONS																	18.4
OS04	0.22	102	FROM SCS CALCULATIONS																	39.6
A01	0.39	5.3	165	10.0	6.1%	9.2	950	11	1.2%	P	20	2.2	7.4	16.6	1115.00	16.2	16.2			
A02	0.45	4.3	95	2.0	2.1%	9.1	1080	10.5	1.0%	P	20	2.0	9.1	18.3	1175.00	16.5	16.5			
A03	0.45	5.5	140	7.0	5.0%	8.2	1040	8.0	0.8%	P	20	1.8	9.9	18.1	1180.00	16.6	16.6			
A04	0.45	4.7	140	3.0	2.1%	10.9	815	10.0	1.2%	P	20	2.2	6.1	17.1	955.00	15.3	15.3			
A05	0.54	2.5	15	0.5	3.3%	5.0	1605	16.0	1.0%	P	20	2.0	13.4	18.4	1620.00	19.0	18.4			
A06	0.45	4.5	140	7.0	5.0%	8.2	620	11.0	1.8%	P	20	2.7	3.9	12.1	760.00	14.2	12.1			
A07	0.45	3.6	140	3.0	2.1%	10.9	705	6.0	0.9%	P	20	1.8	6.4	17.3	845.00	14.7	14.7			
A08	0.45	3.3	145	3.0	2.1%	11.3	700	4.0	0.6%	P	20	1.5	7.7	19.0	845.00	14.7	14.7			
A09	0.44	5.3	100	2.0	2.0%	9.6	1100	22.0	2.0%	P	20	2.8	6.5	16.1	1200.00	16.7	16.1			
A10	0.37	2.0	85	6.0	7.1%	6.5	1235	13.0	1.1%	L	7	0.7	28.7	35.1	1320.00	17.3	17.3			
A11	0.31	1.8	145	9.0	6.2%	9.5	380	4.0	1.1%	L	7	0.7	8.8	18.3	525.00	12.9	12.9			
A12	0.49	9.9	50	1.0	2.0%	6.3	2070	40.0	1.9%	P	20	2.8	12.4	18.7	2120.00	21.8	18.7			

Notes:	$* T_i = \frac{0.395 (1.1 - C_s) L^{0.5}}{S^{0.33}}$
	$V = C_v S_w^{0.5} \quad ** T_t = L \times V$

Per DCM adopted Ch6, length of overland flow for urban uses is max 100 ft.

TYPE OF SURFACE	C _v
HEAVY MEADOW	H 2.5
TILLAGE/FIELD	T 5
RIPRAP (not buried)	R 6.5
SHORT PASTURE AND LAWNS	L 7
NEARLY BARE GROUND	B 10
GRASSED WATERWAY	G 15
PAVED AREAS	P 20

**STORM DRAINAGE SYSTEM DESIGN
(RATIONAL METHOD PROCEDURE)
SURFACE ROUTING**

PROJECT: **The Sanctuary PDR-FDR**

Date: 4/27/2022

DESIGN POINT	DIRECT RUNOFF											TOTAL RUNOFF						OVERLAND TRAVEL TIME								
	BASIN	AREA (AC)	Tc (Min.)	I (in./hr.)		COEFF. ©		CA		q		Sum Tc (min.)	I (in./hr.)		CA		q		DESTINATION DP	CONVEYANCE TYPE	COEFFICIENT Cv	SLOPE %	VEL. (FPS)	LENGTH (FT)	TRAVEL TIME TT	
				(5 YR)	(100 YR)	(5 YR)	(100 YR)	(5 YR)	(100 YR)	(5 YR)	(100 YR)		(5 YR)	(100 YR)	(5 YR)	(100 YR)										
DEVELOPED																										
DP1	OS01	26.6	22.9	2.89	4.85	0.37	0.47	9.92	12.38	29	60							29	60							
I01	OS02	3.0	15.7	3.45	5.79	0.40	1.10	1.20	3.32	4.1	19							3.6	19							
I02	OS03	6.6	18.4	3.21	5.39	0.35	0.53	2.31	3.50	7.4	19							7.4	19							
I03	A01	5.3	16.2	3.41	5.72	0.39	0.55	2.03	2.92	6.9	17							6.9	17	I04	P	20.0	1.00%	2.0	150	1.3
I04	A02	4.3	16.5	3.38	5.67	0.45	0.59	1.94	2.54	6.5	14	17.4	3.29	5.53	2.62	3.91		8.6	22	I05	P	20.0	1.00%	2.0	395	3.3
I05	A03	5.5	16.6	3.37	5.66	0.45	0.59	2.48	3.25	8.4	18	20.7	3.04	5.09	3.22	4.76		9.8	24	I06	P	20.0	1.00%	2.0	315	2.6
I06	A04	4.7	15.3	3.49	5.86	0.45	0.59	2.10	2.75	7.3	16	23.4	2.86	4.79	2.79	4.31		8.0	21	I10	P	20.0	0.65%	1.6	900	9.3
I07	A05	2.5	18.4	3.21	5.40	0.54	0.67	1.37	1.68	4.4	9.1							4.4	9.1	I11	P	20.0	1.20%	2.2	475	3.6
I08	A06	4.5	12.1	3.84	6.45	0.45	0.59	2.03	2.66	7.8	17							7.8	17	I09	P	20.0	1.20%	2.2	225	1.7
I09	A07	3.6	14.7	3.55	5.96	0.45	0.59	1.61	2.12	5.7	13	14.7	3.55	5.96	2.16	3.08		7.7	18	I10	P	20.0	1.00%	2.0	225	1.9
I10	A08	3.3	14.7	3.55	5.96	0.45	0.59	1.49	1.95	5.3	12	32.7	2.35	3.95	2.65	4.50		6.2	18	I11	P	20.0	2.00%	2.8	17	0.1
I11	A09	5.3	16.1	3.41	5.73	0.44	0.58	2.32	3.06	7.9	18	32.8	2.35	3.94	2.53	4.41		7.9	18							
	A10	2.0	17.3	3.30	5.55	0.37	0.52	0.74	1.05	2.5	5.8							2.5	5.8		G	15.0	2.00%	2.1	455	3.6
DP3	A11	1.8	12.9	3.75	6.29	0.31	0.47	0.55	0.83	2.1	5.2	20.9	3.02	5.07	1.29	1.88		3.9	9.6							
I12	A12	9.9	18.7	3.19	5.35	0.49	0.65	4.82	6.37	15	34							15	34							
DP2	OS04	102	39.63	2.06	3.46	0.22	0.45	22	45.67	46	158							46	158							

**STORM DRAINAGE SYSTEM DESIGN
INLET CALCULATIONS**

PROJECT: **The Sanctuary PDR-FDR**

Date: 4/27/2022

DP	BASIN	Inlet size L(i)	Proposed or Existing	INLET TYPE	CROSS SLOPE	STREET SLOPE	T _c	Q _{Total}		Q _{Capture}				Q _{Flowby}				DEPTH (max)		SPREAD	
								Q ₅ (cfs)	Q ₁₀₀ (cfs)	Q ₅ (cfs)	Q ₁₀₀ (cfs)	CA _{eqv.} (5-yr)	CA _{eqv.} (100-yr)	Q ₅ (cfs)	Q ₁₀₀ (cfs)	CA _{eqv.} (5-yr)	CA _{eqv.} (100-yr)	Q ₅ (ft)	Q ₁₀₀ (ft)	Q ₅ (ft)	Q ₁₀₀ (ft)
I01	OS02	15	PROP	SUMP	2.0%		15.7	3.6	19	3.6	19	1.05	3.323	-	-	-	-	0.50	0.70		
I02	OS03	15	PROP	SUMP	2.0%		18.4	7.4	19	7.4	19	2.31	3.500	-	-	-	-	0.50	0.70		
I03	A01	15	PROP	FLOW-BY	2.0%	2.0%	16.2	6.9	17	4.6	8.8	1.35	1.542	2.3	7.9	0.69	1.37	0.35	0.45	13.1	18.2
I04	A02	20	PROP	FLOW-BY	2.0%	2.0%	17.4	8.6	22	6.2	13	1.88	2.399	2.5	8.4	0.74	1.52	0.37	0.49	14.2	20.1
I05	A03	20	PROP	FLOW-BY	2.0%	0.75%	20.7	9.8	24	7.7	16	2.53	3.202	2.1	7.9	0.69	1.56	0.44	0.59	17.9	25.2
I06	A04	20	PROP	FLOW-BY	2.0%	0.75%	23.4	8.0	21	6.5	14	2.27	2.980	1.5	6.4	0.52	1.33	0.42	0.56	16.6	23.7
I07	A05	15	PROP	FLOW-BY	2.0%	0.50%	18.4	4.4	9.1	3.7	6.7	1.15	1.246	0.7	2.3	0.22	0.43	0.37	0.46	14.3	18.8
I08	A06	20	PROP	FLOW-BY	2.0%	2.0%	12.1	7.8	17	5.7	11	1.48	1.698	2.1	6.2	0.55	0.97	0.36	0.45	13.7	18.4
I09	A07	15	PROP	FLOW-BY	2.0%	1.0%	14.7	7.7	18	5.4	11	1.53	1.874	2.3	7.2	0.64	1.21	0.39	0.51	15.5	21.5
I10	A08	10	PROP	SUMP	2.0%		32.7	6.2	18	6.2	14	2.65	3.581	-	3.6	-	0.91	0.50	0.60		
I11	A09	20	PROP	SUMP	2.0%		32.8	7.9	18	7.9	18	3.36	4.455	-	-	-	-	0.50	0.60		
I12	A12	20	PROP	SUMP	2.0%		18.7	15	34	15	34	4.82	6.371	-	-	-	-	0.50	1.00		

¹ Forced sump at intersection

**STORM DRAINAGE SYSTEM DESIGN
(RATIONAL METHOD PROCEDURE)
PIPE ROUTING**

18" pipe shown on the CD's. A comment has been provided on the CD's regarding the discrepancy

PROJECT: **The Sanctuary PDR-FDR**

Date: 4/27/2022

UPSTREAM DESIGN POINT	UPSTREAM BASIN	INLET FLOW								SYSTEM FLOW						TRAVEL TIME						
		Tc (Min.)	I (in./hr.)		CA		Q		Sum Tc (min.)	I (in./hr.)		CA		Q		PIPE DIA	ROUGHNESS (n)	DESTINATION DP	SLOPE %	LENGTH (FT)	VEL. (FPS) (Estimate)*	TRAVEL TIME Tt
			(5 YR)	(100 YR)	(5 YR)	(100 YR)	(5 YR)	(100 YR)		(5 YR)	(100 YR)	(5 YR)	(100 YR)	(5 YR)	(100 YR)							
DP01	OS01								22.9	2.89	4.85	9.92	12.38	29	60	36	0.013	J01	1.61%	165	12	0.2
I01	OS02	15.7	3.45	5.79	1.05	3.32	3.6	19						3.6	19	18	0.013	J01	4.28%	5	12	0.0
I02	OS03	18.4	3.21	5.39	2.31	3.50	7.4	19						7.4	19	18	0.013	J01	0.81%	25	5	0.1
J01									23.1	2.87	4.82	13.28	19.20	38	93	42	0.013	J02	0.79%	138	9	0.2
I03	A01	16.2	3.41	5.72	1.35	1.54	4.6	8.8						4.6	8.8	18	0.013	J02	17.13%	5	25	0.0
J02									23.4	2.86	4.79	14.63	20.75	42	99	42	0.013	J03	1.53%	160	13	0.2
I04	A02	17.4	3.29	5.53	1.88	2.40	6.2	13						6.2	13	18	0.013	J03	2.14%	5	9	0.0
J03									23.6	2.84	4.77	16.51	23.15	47	110	48	0.013	J04	1.14%	404	12	0.6
I05	A03	20.7	3.04	5.09	2.53	3.20	7.7	16						7.7	16	24	0.013	J04	2.14%	5	11	0.0
J04									24.1	2.81	4.71	19.03	26.35	53	124	48	0.013	J05	0.68%	330	9	0.6
I06	A04	23.4	2.86	4.79	2.27	2.98	6.5	14						6.5	14	18	0.013	J05	2.40%	4	9	0.0
J05									24.7	2.77	4.65	21.30	29.33	59	136	54	0.013	J06	0.79%	163	11	0.2
J06									25.0	2.76	4.63	21.30	29.33	59	136	54	0.013	J07	0.57%	265	9	0.5
I07	A05	18.4	3.21	5.40	1.15	1.25	3.7	6.7						3.7	6.7	18	0.013	J07	7.74%	25	17	0.0
J07									25.4	2.73	4.58	22.45	30.57	61	140	54	0.013	J11	0.50%	486	9	0.9
I08	A06	12.1	3.84	6.45	1.48	1.70	5.7	11						5.7	11	18	0.013	J08	4.41%	6	13	0.0
J08									12.1	3.84	6.45	1.48	1.70	5.7	11	18	0.013	J09	1.48%	233	7	0.5
I09	A07	14.7	3.55	5.96	1.53	1.87	5.4	11						5.4	11	18	0.013	J09	1.76%	6	8	0.0
J09									12.7	3.78	6.34	3.01	3.57	11	23	24	0.013	J10	0.93%	156	7	0.4
J10									13.0	3.73	6.26	3.01	3.57	11	22	24	0.013	J11	1.13%	93	8	0.2
I10	A08	32.7	2.35	3.95	2.65	3.58	6.2	14						6.2	14	18	0.013	J11	4.09%	4	12	0.0
J11									32.7	2.35	3.95	28.11	37.73	66	149	54	0.013	I11	1.90%	24	17	0.0
I11	A09	32.8	2.35	3.94	3.36	4.45	7.9	18	32.8	2.35	3.94	31.47	42.18	74	166	54	0.013	OS1	1.73%	115	16	0.1
I12	A12	18.7	3.19	5.35	4.82	6.37	15	34	18.7	3.19	5.35	4.82	6.37	15	34	24	0.013	OS3	3.00%	118	13	0.2

pipe routing table indicates 24" pipe

**STORM DRAINAGE SYSTEM DESIGN
HYDRAULICS**

PROJECT: **The Sanctuary PDR-FDR**

Date: **4/27/2022**

Label	Upstrm Node	Dnstrm Node	Inlet CA (acres)	Inlet Tc (min)	Inlet Flow (ft³/s)	System CA (acres)	System Flow Time (min)	System Intensity (in/hr)	Length (ft)	Section Size (in)	Slope (%)	Capacity (Full Flow) (ft³/s)	System Flow (ft³/s)	Velocity (Ave) (ft/s)	Elevation Ground (Upstrm) (ft)	Hydraulic Grade Line (Upstrm) (ft)	Invert (Upstrm) (ft)	Elevation Ground (Dnstrm) (ft)	Hydraulic Grade Line (Dnstrm) (ft)	Invert (Dnstrm) (ft)
P126	DP1	J01	12.38	22.9	61	12.38	22.9	4.85	164.5	36	1.61%	85	61	13	7060.22	7056.2	7053.65	7057.00	7053.6	7051.00
P124	I01	J01	3.32	15.7	19	3.32	15.7	5.80	4.7	18	4.28%	22	19	11	7057.22	7054.9	7052.70	7057.00	7054.7	7052.50
P125	I02	J01	3.50	18.4	19	3.50	18.4	5.40	24.7	18	0.81%	9.5	19	11	7057.22	7055.5	7052.70	7057.00	7054.7	7052.50
P102	J01	J02				19.21	23.1	4.83	138.4	42	0.94%	98	93	12	7057.00	7053.5	7050.50	7056.24	7052.5	7049.20
P117	I03	J02	1.54	16.2	8.9	1.54	16.2	5.72	4.7	18	17.13%	44	8.9	5.0	7056.54	7053.7	7052.00	7056.24	7053.7	7051.20
P103	J02	J03				20.75	23.3	4.80	159.7	42	1.78%	134	100	15	7056.24	7052.3	7049.20	7052.90	7048.7	7046.35
P118	I04	J03	2.40	17.4	13	2.40	17.4	5.54	4.7	18	6.42%	27	13	7.6	7053.19	7050.2	7048.65	7052.90	7050.1	7048.35
P104	J03	J04				23.15	23.5	4.78	419.1	48	0.95%	140	112	12	7052.90	7049.0	7045.85	7048.75	7046.0	7041.85
P119	I05	J04	3.20	20.7	17	3.20	20.7	5.10	4.2	18	2.40%	16	17	9.3	7048.96	7046.7	7044.45	7048.75	7046.6	7044.35
P127	J04	J05				26.35	24.0	4.72	315.0	54	0.76%	172	126	7.9	7048.75	7045.9	7041.35	7046.33	7044.6	7038.95
P121	I06	J05	2.98	23.4	14	2.98	23.4	4.79	4.2	18	2.40%	16	14	8.1	7046.59	7044.9	7042.05	7046.33	7044.8	7041.95
P107	J05	J06				29.33	24.7	4.66	163.3	54	0.77%	172	138	8.7	7046.33	7044.0	7038.95	7045.22	7043.1	7037.70
P108	J06	J07				29.33	25.0	4.62	265.5	54	0.64%	157	137	8.6	7045.22	7042.4	7037.70	7043.52	7041.1	7036.00
P123	I07	J07	1.25	18.4	6.8	1.25	18.4	5.40	24.2	18	0.83%	9.6	6.8	3.8	7043.74	7042.1	7039.20	7043.52	7042.0	7039.00
P109	J07	J11				30.57	25.5	4.57	483.7	54	0.49%	137	141	8.9	7043.52	7041.0	7036.00	7041.10	7038.5	7033.65
P112	I08	J08	1.70	12.1	11.0	1.70	12.1	6.45	5.7	18	4.41%	22	11	6.2	7047.62	7044.8	7043.10	7047.03	7044.7	7042.85
P113	J08	J09				1.70	12.1	6.45	220.0	18	1.66%	14	11	8.5	7047.03	7044.1	7042.85	7043.55	7041.7	7039.20
P122	I09	J09	1.87	14.7	11	1.87	14.7	5.96	5.2	24	1.94%	32	11	3.6	7043.81	7041.7	7039.30	7043.55	7041.7	7039.20
P114	J09	J10				3.57	14.7	5.96	163.8	24	1.04%	23	22	6.8	7043.55	7041.4	7038.70	7042.02	7039.9	7037.00
P115	J10	J11				3.57	15.1	5.89	93.4	24	0.91%	22	21	6.8	7042.02	7039.3	7037.00	7041.10	7038.5	7036.15
P116	I10	J11	3.58	32.7	14	3.58	32.7	3.95	3.7	18	4.09%	21	14	13	7041.33	7038.2	7036.80	7041.10	7037.9	7036.65
P110	J11	I11				37.73	32.7	3.95	23.7	54	1.90%	271	150	18	7041.10	7037.2	7033.65	7041.33	7036.2	7033.20
P111	I11	OS1	4.46	32.8	18	42.18	32.8	3.94	129.3	54	1.78%	262	168	18	7041.33	7035.0	7031.20	7035.00	7031.7	7028.90
P128	DP02	OS2	45.67	39.6	159	45.67	39.6	3.46	617.0	54	0.93%	190	159	13	7064.50	7059.4	7055.75	7060.00	7053.2	7050.00
P129	I12	OS3	6.37	18.7	34	6.37	18.7	5.36	120.0	24	1.00%	23	34	11	7065.10	7063.6	7060.10	7065.00	7060.8	7058.90

Appendix C - Detention Pond Information

STAGE/STORAGE/DISCHARGE CURVES FOR DETENTIOA1:U54N POND ANALYSIS

Meridian Ranch Proposed Detention Pond G - SANCTUARY INTERIM CONDITIONS (G12)

Gieck Basin - El Paso County, Colorado

Data for outlet pipe and grate:

Type	H or V	Dimensions Width (ft.) X Height (ft.)	Dia.(in)	(sqft)		
Circular	Orifice 1a:	V			1.75	Area = 0.017 Elev to cl = 7023.50
Circular	Orifice 1b:	V			1.75	Area = 0.017 Elev to cl = 7024.10
Circular	Orifice 1c:	V			1.75	Area = 0.017 Elev to cl = 7024.80
Rectangular	Orifice 2:	V 8.6		1.04		Area = 8.944 Elev to cl = 7027.62
Rectangular	Orifice 3:	V 2		0.43		Area = 0.860 Elev to cl = 7025.44
Rectangular	Orifice 4:	V 4.1		0.64		Area = 2.624 Elev to cl = 7027.82
Rectangular	Orifice 5:	V 8.6		1.04		Area = 8.944 Elev to cl = 7027.62

Stand Pipe Dimensions

Rec Grate	20	x	8	Elev = 7028.14
Circ. Grate		dia.		Elev = 7028.14

Outlet Culvert Dimensions

	Width (ft.)	H or V	Height (ft.)	Dia. (ft.)	Type
Outlet Culvert	10	x	4		Rectangular
Area	40.0		TOP		
Outlet I. E.	7022.5		7027.50		
Wall Thick.	12	in.			

50 year storage vol.=	20.4
50 year storage elev.=	7029.5
50 year discharge=	307
10 year storage vol.=	11.3
10 year storage elev.=	7027.9
10 year discharge=	50
2 year storage vol.=	5.0
2 year storage elev.=	7026.7
2 year discharge=	5.0

Data for spillway and embankment:

embankment length =	500
embankment elev =	7033.5
spillway length =	130
spillway elevation =	7031.5
100 year storage elev.=	7030.3
100 year storage vol.=	25.7
100 year discharge=	466
5 year storage elev.=	7027.5
5 year storage vol.=	8.7
5 year discharge=	19
WQCV storage elev.=	7025.2
WQCV storage vol.=	0.9
1/2 WQCV storage elev.=	7024.8
1/2 WQCV storage vol.=	0.45

STAGE		STORAGE				DISCHARGE										PIPE		REALIZED CULVERT OUTFLOW	TOTAL FLOW				
ELEV	HEIGHT	AREA		VOLUME		TOP OF BANK	SPILLWAY	ORIFICE					(max outflow)					GRATE (max outflow)		PIPE 1	PIPE 2		
		sqft	acre	acft	cum acft			1a	1b	1c	2	3	4	5	Rectangular								
7023	0	0	0.00	0.0	0.000	-	-	-	-	-	-	-	-	-	-	-	-	-	10		-	-	
7024	1	2285	0.05	0.0	0.026	-	-	0.06	-	-	-	-	-	-	-	-	-	-	51		0.1	0.06	
7025	2	42192	0.97	0.5	0.537	-	-	0.10	0.08	0.04	-	-	-	-	-	-	-	-	111		0.2	0.21	
7026	3	127336	2.92	1.9	2.483	-	-	0.13	0.11	0.09	-	3.1	-	-	-	-	-	-	184		3.4	3.44	
7026.5	3.5	169390	3.89	3.6	4.180	-	-	0.14	0.12	0.10	-	4.3	-	-	-	-	-	-	224		4.6	4.64	
7027	4	211444	4.85	2.2	6.365	-	-	0.15	0.14	0.12	-	5.2	-	-	-	-	-	-	268		5.6	5.59	
7027.5	4.5	234356	5.38	4.6	8.814	-	-	0.16	0.15	0.13	6.5	6.0	-	6.5	-	-	-	-	304		19	19.45	
7028	5	257267	5.91	5.4	11.745	-	-	0.17	0.16	0.14	22.0	6.6	4.3	22.0	-	-	-	-	337		56	55.51	
7028.5	5.5	264583	6.07	5.7	14.541	-	-	0.18	0.17	0.15	40.4	7.2	10.4	40.4	23	-	-	-	373		122	122.30	
7029	6	271899	6.24	6.1	17.819	-	-	0.19	0.18	0.16	50.6	7.8	13.7	50.6	86	-	-	-	406		209	209.39	
7029.5	6.5	277060	6.36	11.7	20.555	-	-	0.21	0.19	0.17	59.0	8.3	16.4	59.0	171	-	-	-	436		315	314.68	
7030	7	282220	6.48	9.4	23.956	-	-	0.21	0.20	0.18	66.4	8.8	18.7	66.4	274	-	-	-	464		435	434.93	
7030.5	7.5	287904	6.61	6.5	27.039	-	-	0.21	0.20	0.19	73.1	9.3	20.7	73.1	392	-	-	-	491		491	490.92	
7031	8	293587	6.74	6.6	30.565	-	-	0.22	0.21	0.20	79.2	9.8	22.5	79.2	522	-	-	-	516		516	516.22	
7031.5	8.5	297735	6.84	6.7	33.762	-	-	0.23	0.22	0.21	84.8	10.2	24.2	84.8	665	-	-	-	540		540	540.33	
7032	9	301883	6.93	3.4	37.203	137.9	137.9	0.23	0.23	0.22	90.1	10.6	25.8	90.1	819	-	-	-	563		563	701.30	
7032.5	9.5	309236	7.10	7.0	40.729	390.0	390.0	0.24	0.23	0.22	95.1	11.0	27.3	95.1	983	-	-	-	586		586	975.59	
7033	10	316589	7.27	3.6	44.320	716.5	716.5	0.25	0.24	0.23	99.9	11.4	28.8	99.9	1,157	-	-	-	607		607	1,323.43	

- Notes:
- 1) Top-of-bank and spillway flows are weir equations from section 11.3.1 in the DCM. $Q=CLH^{1.5}$ (C=3.0)
 - 2) Orifice flows are also from section 11.3.1. $Q=CA(2gH)^{0.5}$ (C=6)
 - 3) Grate flows are determined from equations 7-2 and 7-3. Weir Flow $Q=(3PH^{1.5})/F$, Orifice Flow $Q=4.815*AH^{0.5}$
 - 4) Pipe flows use the lesser of: 1) Inlet control equations 27 & 28, page 146 of HDS No. 5 - or - 2) Allowable Pipe Flow equation on page 11-9 of the DCM. Use Table 9, page 147-148, HDS No. 5 for formulas 26 & 27.

STAGE/STORAGE/DISCHARGE CURVES FOR DETENTION POND ANALYSIS

**Meridian Ranch Proposed Detention Pond G-FUTURE CONDITIONS (G12)
Gieck Basin - El Paso County, Colorado**

Data for outlet pipe and grate:

Type	H or V	Dimensions Width (ft.) X Height (ft.)	Dia.(in)	(sqft)
Circular	Orifice 1a:	V		1.75
	Area =		0.017	Elev to cl =
Circular	Orifice 1b:	V		1.75
	Area =		0.017	Elev to cl =
Circular	Orifice 1c:	V		1.75
	Area =		0.017	Elev to cl =
Rectangular	Orifice 2:	V	8.6	1.04
	Area =		8.944	Elev to cl =
Rectangular	Orifice 3:	V	2	0.43
	Area =		0.860	Elev to cl =
Rectangular	Orifice 4:	V	4.1	0.64
	Area =		2.624	Elev to cl =
Rectangular	Orifice 5:	V	8.6	1.04
	Area =		8.944	Elev to cl =

Stand Pipe Dimensions

Rec Grate	20	x	8	Elev =	7028.14
Circ. Grate		dia.		Elev =	7028.14

Outlet Culvert Dimensions

	Width (ft.)	H or V	Height (ft.)	Dia. (ft.)	Type
Outlet Culvert	10	x	4		Rectangular
Area	40.0		TOP		
Outlet I. E.	7022.5		7027.50		
Wall Thick.	12	in.			

50 year storage vol.=	20.0
50 year storage elev.=	7029.4
50 year discharge=	293
10 year storage vol.=	11.5
10 year storage elev.=	7028.0
10 year discharge=	52
2 year storage vol.=	5.7
2 year storage elev.=	7026.8
2 year discharge=	5.3

Data for spillway and embankment:

embankment length =	500
embankment elev =	7033.5
spillway length =	130
spillway elevation =	7031.5
100 year storage elev.=	7030.1
100 year storage vol.=	24.8
100 year discharge=	450
5 year storage elev.=	7027.5
5 year storage vol.=	8.9
5 year discharge=	21
WQCV storage elev.=	7025.2
WQCV storage vol.=	0.9
1/2 WQCV storage elev.=	7024.8
1/2 WQCV storage vol.=	0.45

STAGE		STORAGE				DISCHARGE										PIPE		REALIZED CULVERT OUTFLOW	TOTAL FLOW
ELEV	HEIGHT	AREA		VOLUME		TOP OF BANK	SPILLWAY	ORIFICE					(max outflow)		GRATE (max outflow) Rectangular	PIPE		REALIZED CULVERT OUTFLOW	TOTAL FLOW
		sqft	acre	acft	cum acft			1a	1b	1c	2	3	4	5		1	2		
7023	0	0	0.00	0.0	0.000	-	-	-	-	-	-	-	-	-	-	-	10	-	-
7024	1	2285	0.05	0.0	0.026	-	-	0.06	-	-	-	-	-	-	-	-	51	0.1	0.06
7025	2	42192	0.97	0.5	0.537	-	-	0.10	0.08	0.04	-	-	-	-	-	-	111	0.2	0.21
7026	3	127336	2.92	1.9	2.483	-	-	0.13	0.11	0.09	-	3.1	-	-	-	-	184	3.4	3.44
7026.5	3.5	169390	3.89	3.6	4.180	-	-	0.14	0.12	0.10	-	4.3	-	-	-	-	224	4.6	4.64
7027	4	211444	4.85	2.2	6.365	-	-	0.15	0.14	0.12	-	5.2	-	-	-	-	268	5.6	5.59
7027.5	4.5	234356	5.38	4.6	8.814	-	-	0.16	0.15	0.13	6.5	6.0	-	6.5	-	-	304	19	19.45
7028	5	257267	5.91	5.4	11.745	-	-	0.17	0.16	0.14	22.0	6.6	4.3	22.0	-	-	337	56	55.51
7028.5	5.5	264583	6.07	5.7	14.541	-	-	0.18	0.17	0.15	40.4	7.2	10.4	40.4	23	-	373	122	122.30
7029	6	271899	6.24	6.1	17.819	-	-	0.19	0.18	0.16	50.6	7.8	13.7	50.6	86	-	406	209	209.39
7029.5	6.5	277060	6.36	11.7	20.555	-	-	0.21	0.19	0.17	59.0	8.3	16.4	59.0	171	-	436	315	314.68
7030	7	282220	6.48	9.4	23.956	-	-	0.21	0.20	0.18	66.4	8.8	18.7	66.4	274	-	464	435	434.93
7030.5	7.5	287904	6.61	6.5	27.039	-	-	0.21	0.20	0.19	73.1	9.3	20.7	73.1	392	-	491	491	490.92
7031	8	293587	6.74	6.6	30.565	-	-	0.22	0.21	0.20	79.2	9.8	22.5	79.2	522	-	516	516	516.22
7031.5	8.5	297735	6.84	6.7	33.762	-	-	0.23	0.22	0.21	84.8	10.2	24.2	84.8	665	-	540	540	540.33
7032	9	301883	6.93	3.4	37.203	137.9	137.9	0.23	0.23	0.22	90.1	10.6	25.8	90.1	819	-	563	563	701.30
7032.5	9.5	309236	7.10	7.0	40.729	390.0	390.0	0.24	0.23	0.22	95.1	11.0	27.3	95.1	983	-	586	586	975.59
7033	10	316589	7.27	3.6	44.320	716.5	716.5	0.25	0.24	0.23	99.9	11.4	28.8	99.9	1,157	-	607	607	1,323.43

- Notes:
- 1) Top-of-bank and spillway flows are weir equations from section 11.3.1 in the DCM. $Q=CLH^{1.5}$ (C=3.0)
 - 2) Orifice flows are also from section 11.3.1. $Q=CA(2gH)^{0.5}$ (C=6)
 - 3) Grate flows are determined from equations 7-2 and 7-3. Weir Flow $Q=(3PH^{1.5})/F$, Orifice Flow $Q=4.815*AH^{0.5}$
 - 4) Pipe flows use the lesser of: 1) Inlet control equations 27 & 28, page 146 of HDS No. 5 - or - 2) Allowable Pipe Flow equation on page 11-9 of the DCM. Use Table 9, page 147-148, HDS No. 5 for formulas 26 & 27.

THE SANCTUARY FILING 1 INTERIM CONDITION

Simulation Run: SANCTUARY PDR-FDR-100 YR Reservoir: POND G

Start of Run: 01Jul2015, 00:00 Basin Model: Sanctuary PDR-FDR
End of Run: 02Jul2015, 00:00 Meteorologic Model: SCS TYPE IIA 100YR
Control Specifications: 24 HR-2 MIN.
Volume Units: AC-FT

Computed Results:

Peak Inflow: 658(CFS)	Date/Time of Peak Inflow: 01Jul2015, 12:30
Peak Outflow: 466 (CFS)	Date/Time of Peak Outflow: 01Jul2015, 12:54
Total Inflow: 118 (AC-FT)	Peak Storage: 25.7 (AC-FT)
Total Outflow: 108 (AC-FT)	Peak Elevation: 7130.3 (FT)

Simulation Run: SANCTUARY PDR-FDR -005 YR Reservoir: POND G

Start of Run: 01Jul2015, 00:00 Basin Model: Sanctuary PDR-FDR
End of Run: 02Jul2015, 00:00 Meteorologic Model: SCS TYPE IIA 005YR
Control Specifications: 24 HR-2 MIN.
Volume Units: AC-FT

Computed Results:

Peak Inflow: 81 (CFS)	Date/Time of Peak Inflow: 01Jul2015, 12:36
Peak Outflow: 19 (CFS)	Date/Time of Peak Outflow: 01Jul2015, 16:18
Total Inflow: 20.7 (AC-FT)	Peak Storage: 8.7 (AC-FT)
Total Outflow: 13.4 (AC-FT)	Peak Elevation: 7127.5 (FT)

Simulation Run: F-100 YR Reservoir: POND G

Start of Run: 01Jul2015, 00:00 Basin Model: Future SCS
End of Run: 02Jul2015, 00:00 Meteorologic Model: SCS TYPE IIA 100YR
Control Specifications: 24 HR-2 MIN.

Volume Units: AC-FT

Computed Results:

Peak Inflow: 653 (CFS)	Date/Time of Peak Inflow: 01Jul2015, 12:24
Peak Outflow: 450 (CFS)	Date/Time of Peak Outflow: 01Jul2015, 12:48
Total Inflow: 113 (AC-FT)	Peak Storage: 24.8 (AC-FT)
Total Outflow: 103 (AC-FT)	Peak Elevation: 7030.1 (FT)

Simulation Run: F-010 YR Reservoir: POND G

Start of Run: 01Jul2015, 00:00 Basin Model: Future SCS
End of Run: 02Jul2015, 00:00 Meteorologic Model: SCS TYPE IIA 005YR
Control Specifications: 24 HR-2 MIN.

Volume Units: AC-FT

Computed Results:

Peak Inflow: 101 (CFS)	Date/Time of Peak Inflow: 01Jul2015, 12:24
Peak Outflow: 21 (CFS)	Date/Time of Peak Outflow: 01Jul2015, 15:24
Total Inflow: 21.6 (AC-FT)	Peak Storage: 8.9 (AC-FT)
Total Outflow: 14.4 (AC-FT)	Peak Elevation: 7027.5 (FT)

Appendix D – Outlet Protection Design

Again, enter Figure HS-19a using the smaller d/D (or d/H) ratio to find the A/A_{full} ratio. Then,

$$A = (A/A_{full})A_{full} \quad (\text{HS-16c})$$

Finally,

$$V = Q/A \quad (\text{HS-16d})$$

In which for Equations 16a through 16d above:

A_{full} = cross-sectional area of the pipe (ft²)

A = area of the design flow in the end of the pipe (ft²)

n = Manning's n for the pipe full depth

Q_{full} = pipe full discharge at its slope (cfs)

R = hydraulic radius of the pipe flowing full, ft [$R_{full} = D/4$ for circular pipes, $R_{full} = A_{full}/(2H + 2w)$ for rectangular pipes, where D = diameter of a circular conduit, H = height of a rectangular conduit, and w = width of a rectangular conduit (ft)]

S_o = longitudinal slope of the pipe (ft/ft)

V = design flow velocity at the pipe outlet (ft/sec)

V_{full} = flow velocity of the pipe flowing full (ft/sec)

3.4.3.2 Riprap Size

For the design velocity, use [Figure HS-20c](#) to find the size and type of the riprap to use in the scour protection basin downstream of the pipe outlet (i.e., B18, H, M or L). First, calculate the riprap sizing design parameter, P_d , namely,

$$P_d = (V^2 + gd)^{1/2} \quad (\text{HS-16e})$$

in which:

V = design flow velocity at pipe outlet (ft/sec)

g = acceleration due to gravity = 32.2 ft/sec²

d = design depth of flow at pipe outlet (ft)

necessary when the receiving or downstream channel may have little or no flow or tailwater at time when the pipe or culvert is in operation. Design criteria are provided in Figures HS-19a through HS-20c.

3.4.2 Objective

By providing a low tailwater basin at the end of a storm sewer conduit or culvert, the kinetic energy of the discharge is dissipated under controlled conditions without causing scour at the channel bottom.

[Photograph HS-12](#) shows a fairly large low tailwater basin.

3.4.3 Low Tailwater Basin Design

Low tailwater is defined as being equal to or less than $\frac{1}{3}$ of the height of the storm sewer, that is:

$$y_t \leq \frac{D}{3} \quad \text{or} \quad y_t \leq \frac{H}{3}$$

in which:

y_t = tailwater depth at design

D = diameter of circular pipe (ft)

H = height of rectangular pipe (ft)

3.4.3.1 Finding Flow Depth and Velocity of Storm Sewer Outlet Pipe

The first step in the design of a scour protection basin at the outlet of a storm sewer is to find the depth and velocity of flow at the outlet. Pipe-full flow can be found using Manning's equation.

$$Q_{full} = \frac{1.49}{n} A_{full} (R_{full})^{2/3} S_o^{1/2} \quad (\text{HS-16a})$$

Then and the pipe-full velocity can be found using the continuity equation.

$$V_{full} = Q_{full} / A_{full} \quad (\text{HS-16a})$$

The normal depth of flow, d , and the velocity in a conduit can be found with the aid of [Figure HS-20a](#) and [Figure HS-20b](#). Using the known design discharge, Q , and the calculated pipe-full discharge, Q_{full} , enter Figure HS-20a with the value of Q/Q_{full} and find d/D for a circular pipe or d/H for a rectangular pipe.

Compare the value of d/D (or d/H) with the one obtained from Figure HS-20b using the Froude parameter.

$$Q/D^{2.5} \quad \text{or} \quad Q/(wH^{1/5}) \quad (\text{HS-16a})$$

Choose the smaller of the two (d/D or d/H) ratios to calculate the flow depth at the end of the pipe.

$$d = D(d/D) \quad \text{or} \quad d = H(d/H) \quad (\text{HS-16b})$$

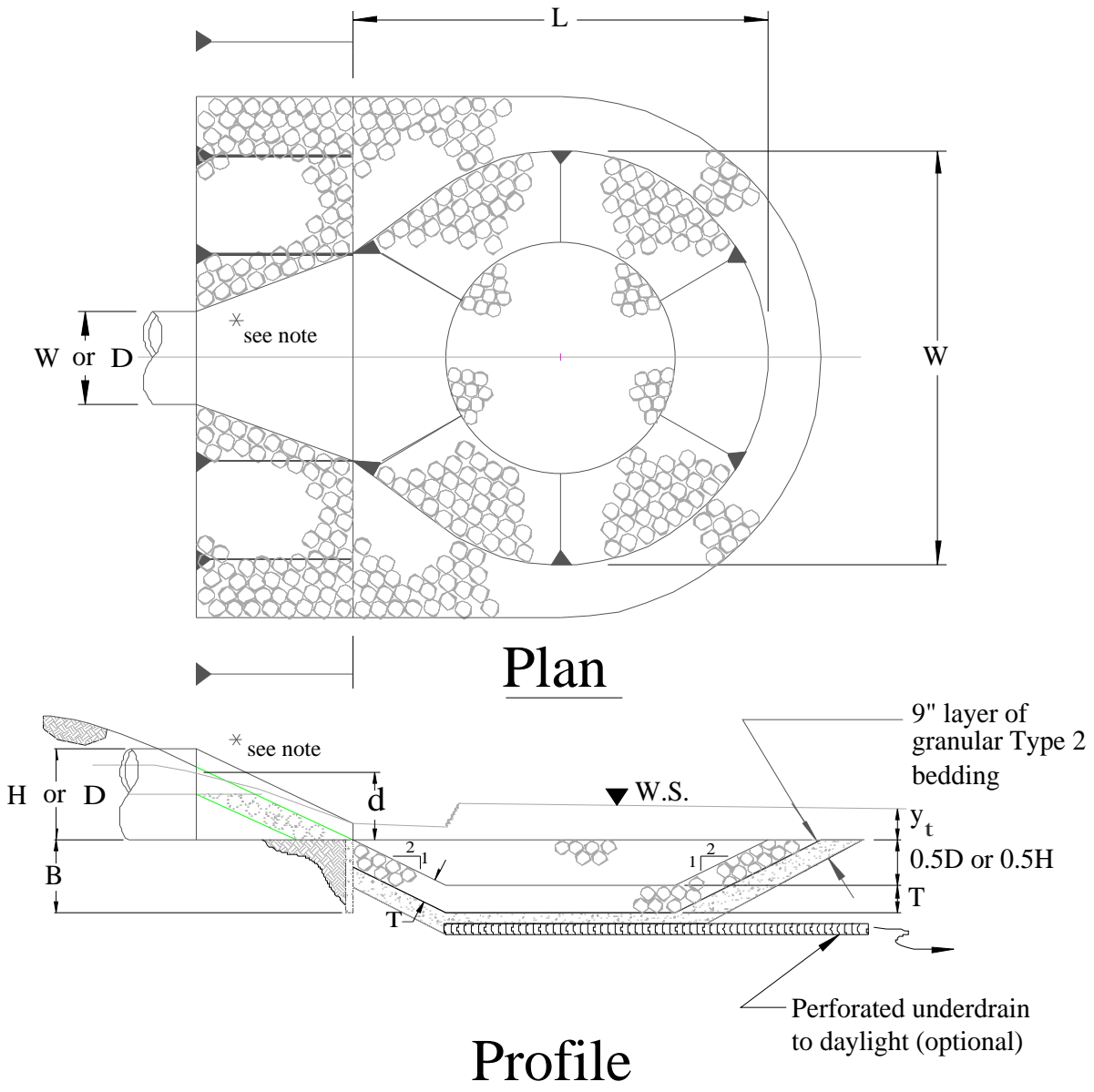

* Note: For rectangular conduits use a standard design for a headwall with wingwalls, paved bottom between the wingwalls, with an end cutoff wall extending to a minimum depth equal to B

**Figure HS-19—Low Tailwater Riprap Basins for Storm Sewer Pipe Outlets—
Low Tailwater Basin at Pipe Outlets
(Stevens and Urbonas 1996)**

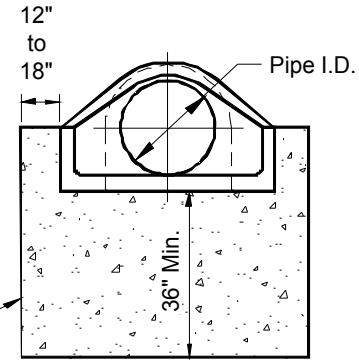
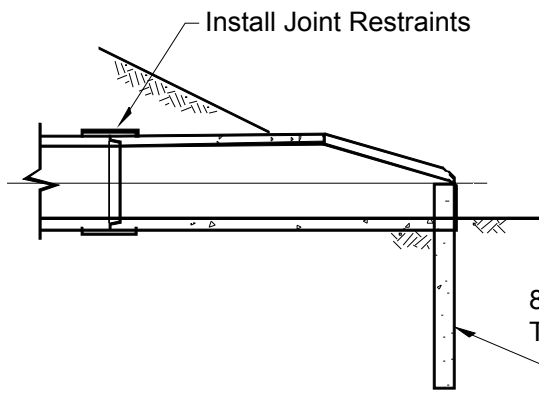
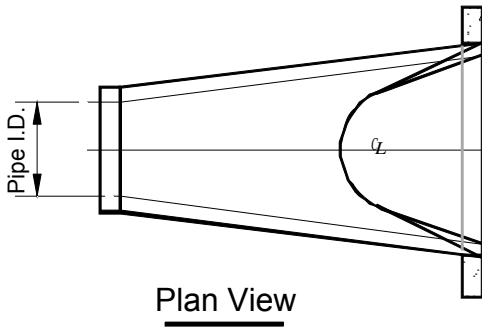

Figure HS-19a—Concrete Flared End Section with Cutoff Wall for all Pipe Outlets



Photograph HS-12—Upstream and downstream views of a low tailwater basin in Douglas County protecting downstream wetland area. Burying and revegetation of the rock would blend the structure better with the adjacent terrain.

When the riprap sizing design parameter indicates conditions that place the design above the Type H riprap line in [Figure HS-20](#), use B18, or larger, grouted boulders. An alternative to a grouted boulder or loose riprap basin is to use the standard USBR Impact Basin VI or one of its modified versions, described earlier in this Chapter of the *Manual*.

After the riprap size has been selected, the minimum thickness of the riprap layer, T , in feet, in the basin is set at:

$$T = 1.75D_{50} \tag{HS-17}$$

in which:

D_{50} = the median size of the riprap (see Table HS-9.)

Table HS-9—Median (i.e., D_{50}) Size of District's Riprap/Boulder

Riprap Type	D_{50} —Median Rock Size (inches)
L	9
M	12
H	18
B18	18 (minimum dimension of grouted boulders)

3.4.3.3 Basin Length

The minimum length of the basin, L , in [Figure HS-19](#), is defined as being the greater of the following:

for circular pipe: $L = 4D$ or $L = (D)^{1/2} \left(\frac{V}{2} \right)$ (HS-18)

for rectangular pipe: $L = 4H$ or $L = (H)^{1/2} \left(\frac{V}{2} \right)$ (HS-19)

in which:

L = basin length

H = height of rectangular conduit

V = design flow velocity at outlet

D = diameter of circular conduit

3.4.3.4 Basin Width

The minimum width, W , of the basin downstream of the pipe's flared end section is set as follows:

for circular pipes: $W = 4D$ (HS-20)

for rectangular pipe: $W = w + 4H$ (HS-21)

in which,

W = basin width ([Figure HS-19](#))

D = diameter of circular conduit

w = width of rectangular conduit

3.4.3.5 Other Design Requirements

All slopes in the pre-shaped riprapped basin are 2H to 1V.

Provide pipe joint fasteners and a structural concrete cutoff wall at the end of the flared end section for a circular pipe or a headwall with wingwalls and a paved bottom between the walls, both with a cutoff wall that extends down to a depth of:

$$B = \frac{D}{2} + T \text{ or } B = \frac{H}{2} + T \quad (\text{HS-22})$$

in which,

B = cutoff wall depth

D = diameter of circular conduit

T = Equation HS-17

The riprap must be extended up the outlet embankment's slope to the mid-pipe level.

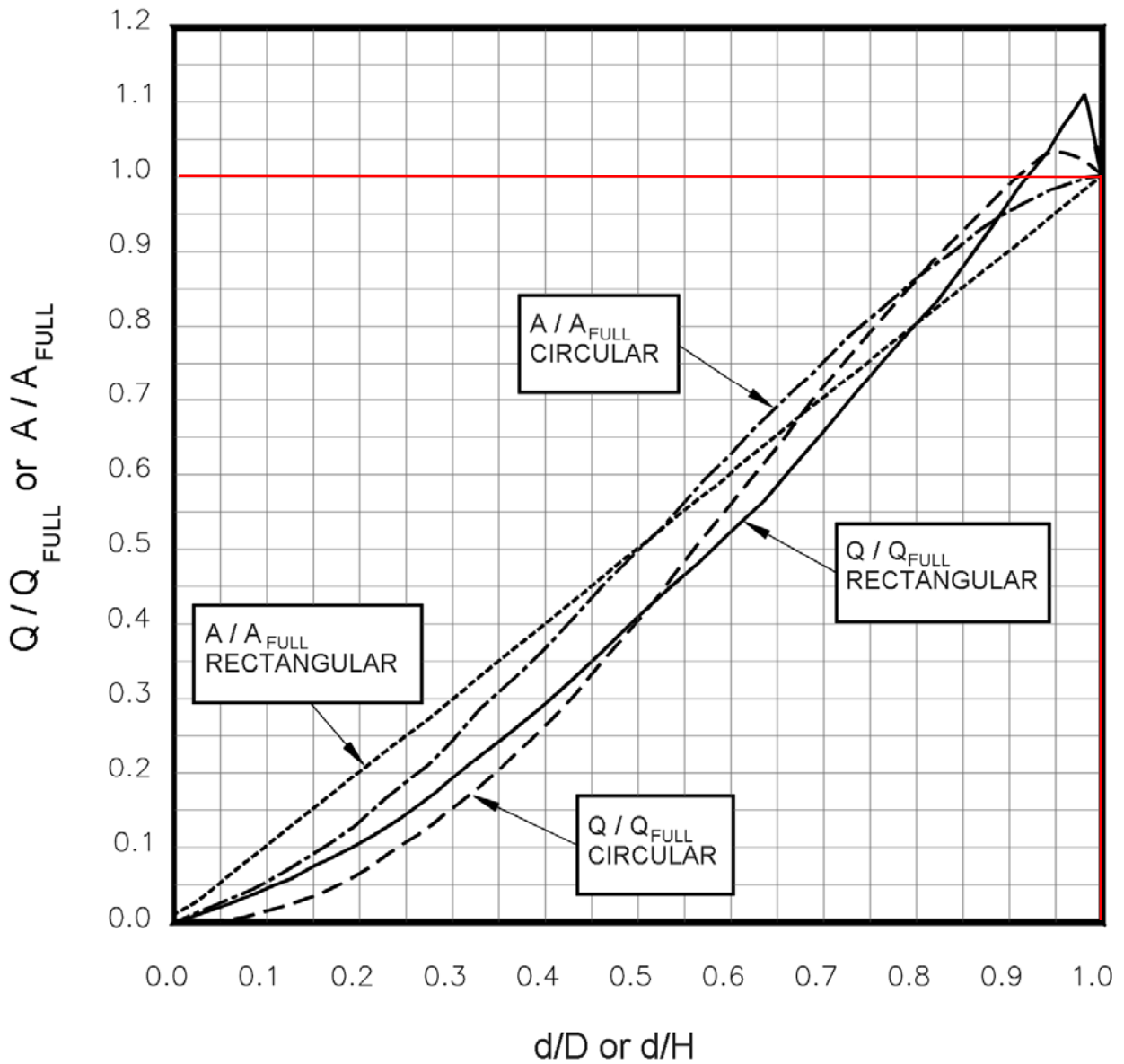

**Figure HS-20a—Low Tailwater Riprap Basins for Storm Sewer Pipe Outlets—
Discharge and Flow Area Relationships for Circular and Rectangular Pipes**
(Ratios for Flow Based on Manning's *n* Varying With Depth)
(Stevens and Urbonas 1996)

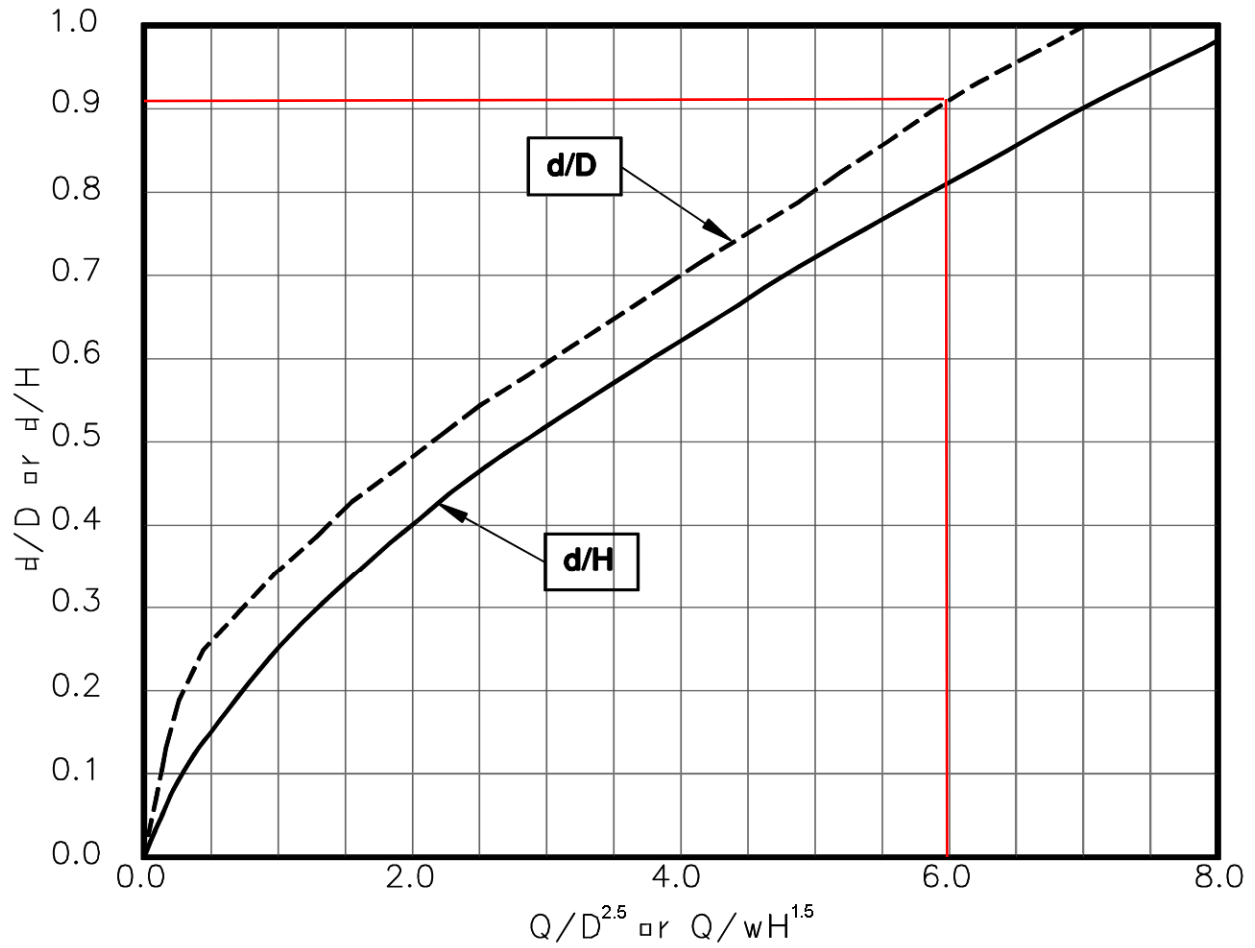

**Figure HS-20b—Low Tailwater Riprap Basins for Storm Sewer Pipe Outlets—
Brink Depth for Horizontal Pipe Outlets**
(Stevens and Urbonas 1996)

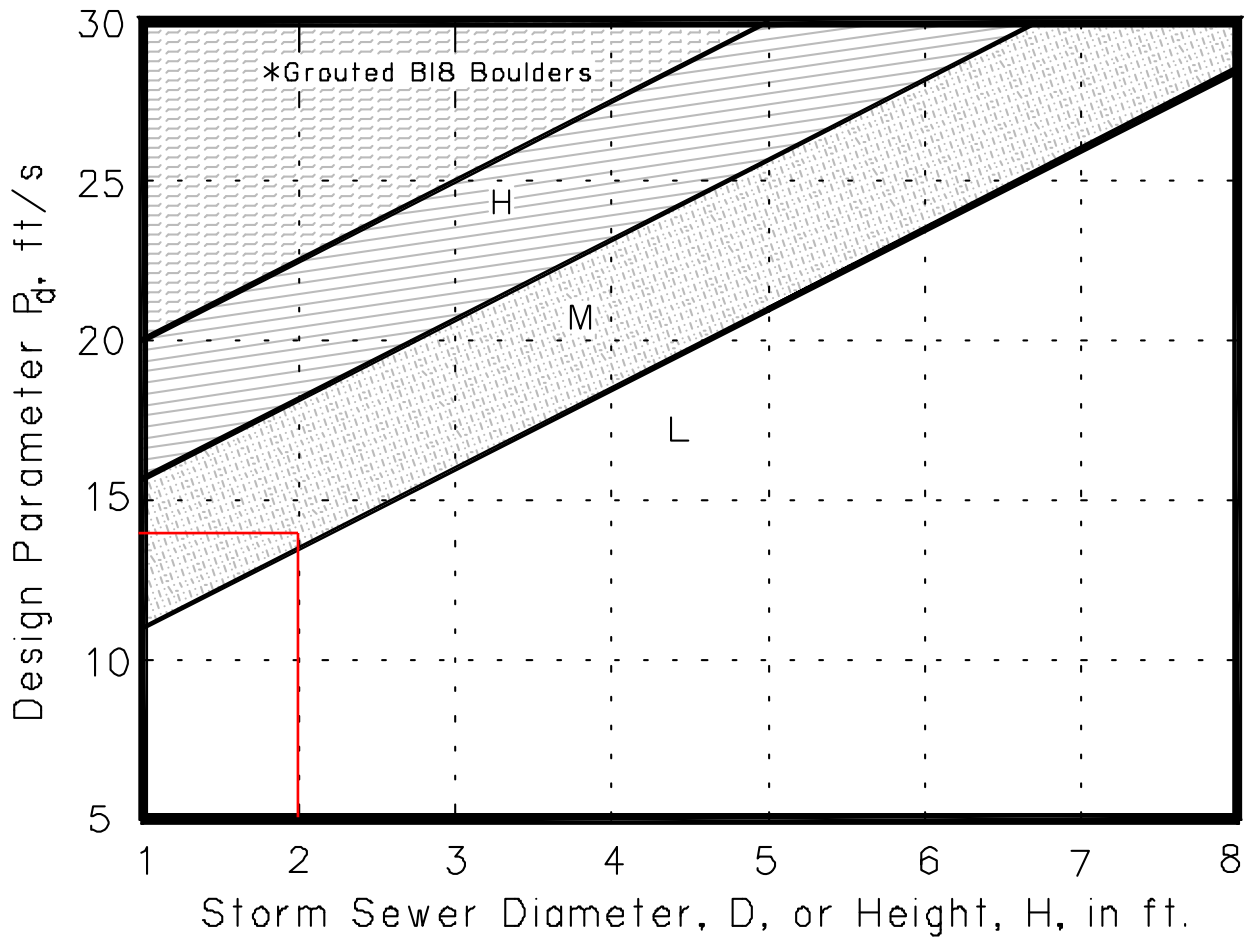

**Figure HS-20c—Low Tailwater Riprap Basins for Storm Sewer Pipe Outlets—
Riprap Selection Chart for Low Tailwater Basin at Pipe Outlet**
(Stevens and Urbonas 1996)

RIP RAP PLUNGE POOL

Urban Drainage & Flood Control District Pipe Outlet Design
Low Tailwater Design ($y_t \leq D/3$)

OUTLET # **OS3**

Outlet Size (D) :	24	in.	Discharge (q):	34	CFS
Capacity (Q): (full flow)	23	CFS	Flow depth (d): (calculated)	21.8	in.

Q _{full} =	23 CFS	q/Q _{full} =	1.48
A _{full} =	3.1 SF		
V _{full} =	7.3 FPS	Q/D ^{2.5} =	6.0

d/D	1.00	from HS-20a using q/Q _{full}
d/D	0.91	from HS-20b using Q/D ^{2.5}

A' (A/A _{full})	0.91	from HS-20a using smaller d/D from above	Flow Area (a=A' x A _{full})	2.9	SF
------------------------------	------	---	--	-----	----

Outlet Velocity (V = q/a) 11.9 FPS

$P_d = (V^2 + gd)^{1/2} =$ 14

RIP-RAP SIZE: **M** from HS-20c

d₅₀ = 12 in T=1.75xd₅₀ 1.75 ft

Basin Length (L)	8.4 FT.	Cutoff Wall Depth	2.75	FT
Basin Width (W)	8.0 FT.	(B=D/2+T)		

Appendix E – Street Flow

Worksheet for Ramp Full Street Section

Project Description

Friction Method Manning Formula
 Solve For Discharge

Input Data

Channel Slope 0.00500 ft/ft
 Normal Depth 0.75 ft
 Section Definitions

Station (ft)	Elevation (ft)
0+00	0.00
0+13	-0.25
0+14	-0.75
0+15	-0.59
0+30	-0.29
0+45	-0.59
0+46	-0.75
0+48	-0.25
0+60	0.00

Roughness Segment Definitions

Start Station	Ending Station	Roughness Coefficient
(0+00, 0.00)	(0+13, -0.25)	0.030
(0+13, -0.25)	(0+15, -0.59)	0.013
(0+15, -0.59)	(0+45, -0.59)	0.015
(0+45, -0.59)	(0+48, -0.25)	0.013
(0+48, -0.25)	(0+60, 0.00)	0.030
<None>	(0+60, 0.00)	0.030

Options

Current Roughness Weighted Method Pavlovskii's Method
 Open Channel Weighting Method Pavlovskii's Method
 Closed Channel Weighting Method Pavlovskii's Method

Worksheet for Ramp Full Street Section

Results

Discharge		42.54	ft ³ /s
Elevation Range	-0.75 to 0.00 ft		
Flow Area		19.32	ft ²
Wetted Perimeter		60.21	ft
Hydraulic Radius		0.32	ft
Top Width		60.00	ft
Normal Depth		0.75	ft
Critical Depth		0.66	ft
Critical Slope		0.01121	ft/ft
Velocity		2.20	ft/s
Velocity Head		0.08	ft
Specific Energy		0.83	ft
Froude Number		0.68	
Flow Type	Subcritical		

GVF Input Data

Downstream Depth	0.00	ft
Length	0.00	ft
Number Of Steps	0	

GVF Output Data

Upstream Depth	0.00	ft
Profile Description		
Profile Headloss	0.00	ft
Downstream Velocity	Infinity	ft/s
Upstream Velocity	Infinity	ft/s
Normal Depth	0.75	ft
Critical Depth	0.66	ft
Channel Slope	0.00500	ft/ft
Critical Slope	0.01121	ft/ft

Cross Section for Ramp Full Street Section

Project Description

Friction Method Manning Formula
Solve For Discharge

Input Data

Channel Slope	0.00500	ft/ft
Normal Depth	0.75	ft
Discharge	42.54	ft ³ /s

Cross Section Image

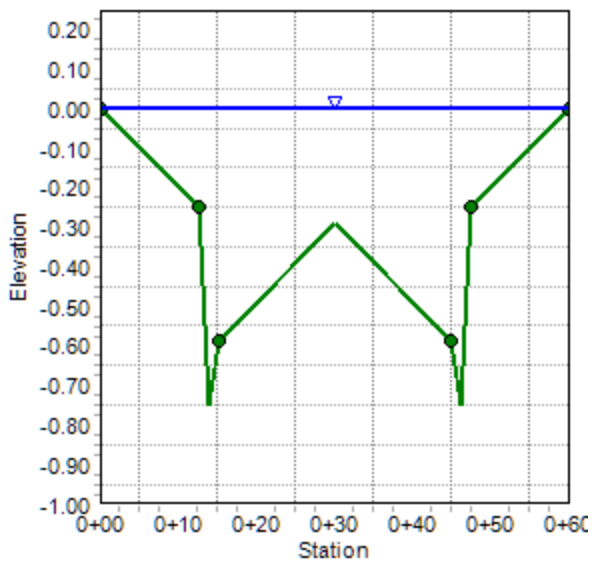

RESIDENTIAL STREET SECTION
RAMP CURB

5-Year Storm Event Maximum Allowable Street Flows (Maximum Flow to Top of Curb)									
Channel Slope (ft/ft)	Full Street Width					Half Street Width			
	Discharge (ft ³ /s)	Velocity (ft/s)	Flow Area (ft ²)	Wetted Perimeter (ft)	Top Width (ft)	Discharge (ft ³ /s)	Velocity (ft/s)	Flow Area (ft ²)	Top Width (ft)
0.0050	19	2.5	7.45	35.2	35.0	9.4	2.5	3.7	17.5
0.0063	21	2.8	7.45	35.2	35.0	11	2.8	3.7	17.5
0.0075	23	3.1	7.45	35.2	35.0	12	3.1	3.7	17.5
0.0088	25	3.4	7.45	35.2	35.0	12	3.3	3.7	17.5
0.0100	27	3.6	7.45	35.2	35.0	13	3.6	3.7	17.5
0.0113	28	3.8	7.45	35.2	35.0	14	3.8	3.7	17.5
0.0125	30	4.0	7.45	35.2	35.0	15	4.0	3.7	17.5
0.0138	31	4.2	7.45	35.2	35.0	16	4.2	3.7	17.5
0.0150	33	4.4	7.45	35.2	35.0	16	4.4	3.7	17.5
0.0163	34	4.6	7.45	35.2	35.0	17	4.5	3.7	17.5
0.0175	35	4.7	7.45	35.2	35.0	18	4.7	3.7	17.5
0.0188	37	4.9	7.45	35.2	35.0	18	4.9	3.7	17.5
0.0200	38	5.1	7.45	35.2	35.0	19	5.0	3.7	17.5
0.0213	39	5.2	7.45	35.2	35.0	19	5.2	3.7	17.5
0.0225	40	5.4	7.45	35.2	35.0	20	5.4	3.7	17.5
0.0238	41	5.5	7.45	35.2	35.0	20	5.5	3.7	17.5
0.0250	42	5.7	7.45	35.2	35.0	21	5.6	3.7	17.5
0.0263	43	5.8	7.45	35.2	35.0	22	5.8	3.7	17.5
0.0275	44	5.9	7.45	35.2	35.0	22	5.9	3.7	17.5
0.0288	45	6.1	7.45	35.2	35.0	23	6.0	3.7	17.5
0.0300	46	6.2	7.45	35.2	35.0	23	6.2	3.7	17.5
0.0313	47	6.3	7.45	35.2	35.0	23	6.3	3.7	17.5
0.0325	48	6.5	7.45	35.2	35.0	24	6.4	3.7	17.5
0.0338	49	6.6	7.45	35.2	35.0	24	6.6	3.7	17.5
0.0350	50	6.7	7.45	35.2	35.0	25	6.7	3.7	17.5
0.0363	51	6.8	7.45	35.2	35.0	25	6.8	3.7	17.5
0.0375	52	6.9	7.45	35.2	35.0	26	6.9	3.7	17.5
0.0388	53	7.1	7.45	35.2	35.0	26	7.0	3.7	17.5
0.0400	53	7.2	7.45	35.2	35.0	27	7.1	3.7	17.5

100-Year Storm Event Maximum Allowable Street Flows (Maximum Flow to Right-of-Way)									
Channel Slope (ft/ft)	Full Street Width					Half Street Width			
	Discharge (ft ³ /s)	Velocity (ft/s)	Flow Area (ft ²)	Wetted Perimeter (ft)	Top Width (ft)	Discharge (ft ³ /s)	Velocity (ft/s)	Flow Area (ft ²)	Top Width (ft)
0.0050	43	2.2	19.32	60.2	60.0	21	2.2	9.7	30
0.0063	48	2.5	19.32	60.2	60.0	24	2.4	9.7	30
0.0075	52	2.7	19.32	60.2	60.0	26	2.7	9.7	30
0.0088	56	2.9	19.32	60.2	60.0	28	2.9	9.7	30
0.0100	60	3.1	19.32	60.2	60.0	30	3.1	9.7	30
0.0113	64	3.3	19.32	60.2	60.0	32	3.3	9.7	30
0.0125	67	3.5	19.32	60.2	60.0	33	3.5	9.7	30
0.0138	71	3.7	19.32	60.2	60.0	35	3.6	9.7	30
0.0150	74	3.8	19.32	60.2	60.0	36	3.8	9.7	30
0.0163	77	4.0	19.32	60.2	60.0	38	3.9	9.7	30
0.0175	80	4.1	19.32	60.2	60.0	39	4.1	9.7	30
0.0188	82	4.3	19.32	60.2	60.0	41	4.2	9.7	30
0.0200	85	4.4	19.32	60.2	60.0	42	4.4	9.7	30
0.0213	88	4.5	19.32	60.2	60.0	43	4.5	9.7	30
0.0225	90	4.7	19.32	60.2	60.0	45	4.6	9.7	30
0.0238	93	4.8	19.32	60.2	60.0	46	4.8	9.7	30
0.0250	95	4.9	19.32	60.2	60.0	47	4.9	9.7	30
0.0263	97	5.0	19.32	60.2	60.0	48	5.0	9.7	30
0.0275	100	5.2	19.32	60.2	60.0	49	5.1	9.7	30
0.0288	102	5.3	19.32	60.2	60.0	50	5.2	9.7	30
0.0300	104	5.4	19.32	60.2	60.0	52	5.3	9.7	30
0.0313	106	5.5	19.32	60.2	60.0	53	5.5	9.7	30
0.0325	108	5.6	19.32	60.2	60.0	54	5.6	9.7	30
0.0338	111	5.7	19.32	60.2	60.0	55	5.7	9.7	30
0.0350	113	5.8	19.32	60.2	60.0	56	5.8	9.7	30
0.0363	115	5.9	19.32	60.2	60.0	57	5.9	9.7	30
0.0375	117	6.0	19.32	60.2	60.0	58	6.0	9.7	30
0.0388	118	6.1	19.32	60.2	60.0	59	6.1	9.7	30
0.0400	120	6.2	19.32	60.2	60.0	60	6.2	9.7	30

the proposed roads have a 50 ft. ROW. not 60'. Revise accordingly.

Street Flows Ramp Curb
(Maximum Flow to Crown of Roadway)

Channel Slope (ft/ft)	Full Street Width					Half Street Width			
	Discharge (ft ³ /s)	Velocity (ft/s)	Flow Area (ft ²)	Wetted Perimeter (ft)	Top Width (ft)	Discharge (ft ³ /s)	Velocity (ft/s)	Flow Area (ft ²)	Top Width (ft)
0.0050	13	2.2	6.05	35.0	34.8	6.7	2.2	3.0	17.4
0.0063	15	2.5	6.05	35.0	34.8	7.5	2.5	3.0	17.4
0.0075	16	2.7	6.05	35.0	34.8	8.2	2.7	3.0	17.4
0.0088	18	2.9	6.05	35.0	34.8	8.9	2.9	3.0	17.4
0.0100	19	3.1	6.05	35.0	34.8	9.5	3.1	3.0	17.4
0.0113	20	3.3	6.05	35.0	34.8	10	3.3	3.0	17.4
0.0125	21	3.5	6.05	35.0	34.8	11	3.5	3.0	17.4
0.0138	22	3.7	6.05	35.0	34.8	11	3.7	3.0	17.4
0.0150	23	3.8	6.05	35.0	34.8	12	3.8	3.0	17.4
0.0163	24	4.0	6.05	35.0	34.8	12	4.0	3.0	17.4
0.0175	25	4.1	6.05	35.0	34.8	13	4.1	3.0	17.4
0.0188	26	4.3	6.05	35.0	34.8	13	4.3	3.0	17.4
0.0200	27	4.4	6.05	35.0	34.8	13	4.4	3.0	17.4
0.0213	28	4.6	6.05	35.0	34.8	14	4.6	3.0	17.4
0.0225	28	4.7	6.05	35.0	34.8	14	4.7	3.0	17.4
0.0238	29	4.8	6.05	35.0	34.8	15	4.8	3.0	17.4
0.0250	30	5.0	6.05	35.0	34.8	15	5.0	3.0	17.4
0.0263	31	5.1	6.05	35.0	34.8	15	5.1	3.0	17.4
0.0275	31	5.2	6.05	35.0	34.8	16	5.2	3.0	17.4
0.0288	32	5.3	6.05	35.0	34.8	16	5.3	3.0	17.4
0.0300	33	5.4	6.05	35.0	34.8	16	5.4	3.0	17.4
0.0313	34	5.5	6.05	35.0	34.8	17	5.5	3.0	17.4
0.0325	34	5.7	6.05	35.0	34.8	17	5.6	3.0	17.4
0.0338	35	5.8	6.05	35.0	34.8	17	5.8	3.0	17.4
0.0350	35	5.9	6.05	35.0	34.8	18	5.9	3.0	17.4
0.0363	36	6.0	6.05	35.0	34.8	18	6.0	3.0	17.4
0.0375	37	6.1	6.05	35.0	34.8	18	6.1	3.0	17.4
0.0388	37	6.2	6.05	35.0	34.8	19	6.2	3.0	17.4
0.0400	38	6.3	6.05	35.0	34.8	19	6.3	3.0	17.4

Worksheet for Vertical Full Street Section

Project Description

Friction Method Manning Formula
 Solve For Discharge

Input Data

Channel Slope 0.00500 ft/ft
 Normal Depth 0.75 ft
 Section Definitions

Station (ft)	Elevation (ft)
0+00	0.00
0+13	-0.25
0+13	-0.25
0+13	-0.75
0+15	-0.58
0+30	-0.28
0+45	-0.58
0+47	-0.75
0+47	-0.25
0+48	-0.25
0+60	0.00

Roughness Segment Definitions

Start Station	Ending Station	Roughness Coefficient
(0+00, 0.00)	(0+13, -0.25)	0.030
(0+13, -0.25)	(0+15, -0.58)	0.013
(0+15, -0.58)	(0+45, -0.58)	0.015
(0+45, -0.58)	(0+48, -0.25)	0.013
(0+48, -0.25)	(0+60, 0.00)	0.030
<None>	(0+60, 0.00)	0.030

Options

Current Roughness Weighted Method Pavlovskii's Method
 Open Channel Weighting Method Pavlovskii's Method

Worksheet for Vertical Full Street Section

Options

Closed Channel Weighting Method Pavlovskii's Method

Results

Discharge		41.33	ft ³ /s
Elevation Range	-0.75 to 0.00 ft		
Flow Area		19.04	ft ²
Wetted Perimeter		61.02	ft
Hydraulic Radius		0.31	ft
Top Width		60.00	ft
Normal Depth		0.75	ft
Critical Depth		0.66	ft
Critical Slope		0.01143	ft/ft
Velocity		2.17	ft/s
Velocity Head		0.07	ft
Specific Energy		0.82	ft
Froude Number		0.68	
Flow Type	Subcritical		

GVF Input Data

Downstream Depth	0.00	ft
Length	0.00	ft
Number Of Steps	0	

GVF Output Data

Upstream Depth	0.00	ft
Profile Description		
Profile Headloss	0.00	ft
Downstream Velocity	Infinity	ft/s
Upstream Velocity	Infinity	ft/s
Normal Depth	0.75	ft
Critical Depth	0.66	ft
Channel Slope	0.00500	ft/ft
Critical Slope	0.01143	ft/ft

Cross Section for Vertical Full Street Section

Project Description

Friction Method Manning Formula
Solve For Discharge

Input Data

Channel Slope	0.00500	ft/ft
Normal Depth	0.75	ft
Discharge	41.33	ft ³ /s

Cross Section Image

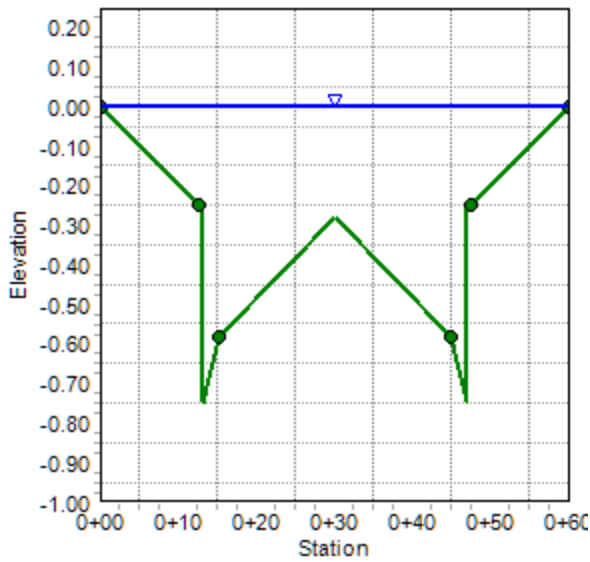

RESIDENTIAL STREET SECTION
VERTICAL CURB

5-Year Storm Event Maximum Allowable Street Flows (Maximum Flow to Top of Curb)									
Channel Slope (ft/ft)	Full Street Width					Half Street Width			
	Discharge (ft ³ /s)	Velocity (ft/s)	Flow Area (ft ²)	Wetted Perimeter (ft)	Top Width (ft)	Discharge (ft ³ /s)	Velocity (ft/s)	Flow Area (ft ²)	Top Width (ft)
0.0050	18	2.5	7.17	35.0	34.0	8.9	2.5	3.6	17
0.0063	20	2.8	7.17	35.0	34.0	9.9	2.8	3.6	17
0.0075	22	3.0	7.17	35.0	34.0	11	3.0	3.6	17
0.0088	23	3.3	7.17	35.0	34.0	12	3.3	3.6	17
0.0100	25	3.5	7.17	35.0	34.0	13	3.5	3.6	17
0.0113	27	3.7	7.17	35.0	34.0	13	3.7	3.6	17
0.0125	28	3.9	7.17	35.0	34.0	14	3.9	3.6	17
0.0138	29	4.1	7.17	35.0	34.0	15	4.1	3.6	17
0.0150	31	4.3	7.17	35.0	34.0	15	4.3	3.6	17
0.0163	32	4.5	7.17	35.0	34.0	16	4.5	3.6	17
0.0175	33	4.6	7.17	35.0	34.0	17	4.6	3.6	17
0.0188	34	4.8	7.17	35.0	34.0	17	4.8	3.6	17
0.0200	36	5.0	7.17	35.0	34.0	18	5.0	3.6	17
0.0213	37	5.1	7.17	35.0	34.0	18	5.1	3.6	17
0.0225	38	5.3	7.17	35.0	34.0	19	5.3	3.6	17
0.0238	39	5.4	7.17	35.0	34.0	19	5.4	3.6	17
0.0250	40	5.5	7.17	35.0	34.0	20	5.5	3.6	17
0.0263	41	5.7	7.17	35.0	34.0	20	5.7	3.6	17
0.0275	42	5.8	7.17	35.0	34.0	21	5.8	3.6	17
0.0288	43	5.9	7.17	35.0	34.0	21	5.9	3.6	17
0.0300	43	6.1	7.17	35.0	34.0	22	6.1	3.6	17
0.0313	44	6.2	7.17	35.0	34.0	22	6.2	3.6	17
0.0325	45	6.3	7.17	35.0	34.0	23	6.3	3.6	17
0.0338	46	6.4	7.17	35.0	34.0	23	6.4	3.6	17
0.0350	47	6.6	7.17	35.0	34.0	23	6.6	3.6	17
0.0363	48	6.7	7.17	35.0	34.0	24	6.7	3.6	17
0.0375	49	6.8	7.17	35.0	34.0	24	6.8	3.6	17
0.0388	49	6.9	7.17	35.0	34.0	25	6.9	3.6	17
0.0400	50	7.0	7.17	35.0	34.0	25	7.0	3.6	17
100-Year Storm Event Maximum Allowable Street Flows (Maximum Flow to Right-of-Way)									
Channel Slope (ft/ft)	Full Street Width					Half Street Width			
	Discharge (ft ³ /s)	Velocity (ft/s)	Flow Area (ft ²)	Wetted Perimeter (ft)	Top Width (ft)	Discharge (ft ³ /s)	Velocity (ft/s)	Flow Area (ft ²)	Top Width (ft)
0.0050	41	2.2	19.04	61.0	60.0	21	2.2	9.5	30
0.0063	46	2.4	19.04	61.0	60.0	23	2.4	9.5	30
0.0075	51	2.7	19.04	61.0	60.0	25	2.7	9.5	30
0.0088	55	2.9	19.04	61.0	60.0	27	2.9	9.5	30
0.0100	58	3.1	19.04	61.0	60.0	29	3.1	9.5	30
0.0113	62	3.3	19.04	61.0	60.0	31	3.2	9.5	30
0.0125	65	3.4	19.04	61.0	60.0	33	3.4	9.5	30
0.0138	69	3.6	19.04	61.0	60.0	34	3.6	9.5	30
0.0150	72	3.8	19.04	61.0	60.0	36	3.8	9.5	30
0.0163	75	3.9	19.04	61.0	60.0	37	3.9	9.5	30
0.0175	77	4.1	19.04	61.0	60.0	39	4.1	9.5	30
0.0188	80	4.2	19.04	61.0	60.0	40	4.2	9.5	30
0.0200	83	4.3	19.04	61.0	60.0	41	4.3	9.5	30
0.0213	85	4.5	19.04	61.0	60.0	42	4.5	9.5	30
0.0225	88	4.6	19.04	61.0	60.0	44	4.6	9.5	30
0.0238	90	4.7	19.04	61.0	60.0	45	4.7	9.5	30
0.0250	92	4.9	19.04	61.0	60.0	46	4.8	9.5	30
0.0263	95	5.0	19.04	61.0	60.0	47	5.0	9.5	30
0.0275	97	5.1	19.04	61.0	60.0	48	5.1	9.5	30
0.0288	99	5.2	19.04	61.0	60.0	49	5.2	9.5	30
0.0300	101	5.3	19.04	61.0	60.0	50	5.3	9.5	30
0.0313	103	5.4	19.04	61.0	60.0	51	5.4	9.5	30
0.0325	105	5.5	19.04	61.0	60.0	52	5.5	9.5	30
0.0338	107	5.6	19.04	61.0	60.0	53	5.6	9.5	30
0.0350	109	5.7	19.04	61.0	60.0	54	5.7	9.5	30
0.0363	111	5.8	19.04	61.0	60.0	55	5.8	9.5	30
0.0375	113	5.9	19.04	61.0	60.0	56	5.9	9.5	30
0.0388	115	6.0	19.04	61.0	60.0	57	6.0	9.5	30
0.0400	117	6.1	19.04	61.0	60.0	58	6.1	9.5	30

see comment above

Street Flows Vertical Curb
(Maximum Flow to Crown of Roadway)

Channel Slope (ft/ft)	Full Street Width					Half Street Width			
	Discharge (ft ³ /s)	Velocity (ft/s)	Flow Area (ft ²)	Wetted Perimeter (ft)	Top Width (ft)	Discharge (ft ³ /s)	Velocity (ft/s)	Flow Area (ft ²)	Top Width (ft)
0.0050	14	2.2	6.15	35.0	34.0	6.7	2.2	3.0	17
0.0063	15	2.5	6.15	35.0	34.0	7.5	2.5	3.0	17
0.0075	17	2.7	6.15	35.0	34.0	8.2	2.7	3.0	17
0.0088	18	3.0	6.15	35.0	34.0	8.8	2.9	3.0	17
0.0100	19	3.2	6.15	35.0	34.0	9.4	3.1	3.0	17
0.0113	21	3.4	6.15	35.0	34.0	10	3.3	3.0	17
0.0125	22	3.5	6.15	35.0	34.0	11	3.5	3.0	17
0.0138	23	3.7	6.15	35.0	34.0	11	3.7	3.0	17
0.0150	24	3.9	6.15	35.0	34.0	12	3.8	3.0	17
0.0163	25	4.0	6.15	35.0	34.0	12	4.0	3.0	17
0.0175	26	4.2	6.15	35.0	34.0	12	4.1	3.0	17
0.0188	27	4.3	6.15	35.0	34.0	13	4.3	3.0	17
0.0200	28	4.5	6.15	35.0	34.0	13	4.4	3.0	17
0.0213	28	4.6	6.15	35.0	34.0	14	4.6	3.0	17
0.0225	29	4.8	6.15	35.0	34.0	14	4.7	3.0	17
0.0238	30	4.9	6.15	35.0	34.0	15	4.8	3.0	17
0.0250	31	5.0	6.15	35.0	34.0	15	4.9	3.0	17
0.0263	32	5.1	6.15	35.0	34.0	15	5.1	3.0	17
0.0275	32	5.3	6.15	35.0	34.0	16	5.2	3.0	17
0.0288	33	5.4	6.15	35.0	34.0	16	5.3	3.0	17
0.0300	34	5.5	6.15	35.0	34.0	16	5.4	3.0	17
0.0313	34	5.6	6.15	35.0	34.0	17	5.5	3.0	17
0.0325	35	5.7	6.15	35.0	34.0	17	5.6	3.0	17
0.0338	36	5.8	6.15	35.0	34.0	17	5.7	3.0	17
0.0350	36	5.9	6.15	35.0	34.0	18	5.9	3.0	17
0.0363	37	6.0	6.15	35.0	34.0	18	6.0	3.0	17
0.0375	38	6.1	6.15	35.0	34.0	18	6.1	3.0	17
0.0388	38	6.2	6.15	35.0	34.0	19	6.2	3.0	17
0.0400	39	6.3	6.15	35.0	34.0	19	6.3	3.0	17

Appendix F – East Grass Swale Analysis

East Swale - Northern Portion

Project Description	
Friction Method	Manning Formula
Solve For	Normal Depth
Input Data	
Roughness Coefficient	0.030
Channel Slope	0.008 ft/ft
Left Side Slope	4.000 H:V
Right Side Slope	4.000 H:V
Discharge	5.80 cfs
Results	
Normal Depth	9.5 in
Flow Area	2.5 ft ²
Wetted Perimeter	6.5 ft
Hydraulic Radius	4.6 in
Top Width	6.31 ft
Critical Depth	8.0 in
Critical Slope	0.020 ft/ft
Velocity	2.33 ft/s
Velocity Head	0.08 ft
Specific Energy	0.87 ft
Froude Number	0.655
Flow Type	Subcritical
GVF Input Data	
Downstream Depth	0.0 in
Length	0.0 ft
Number Of Steps	0
GVF Output Data	
Upstream Depth	0.0 in
Profile Description	N/A
Profile Headloss	0.00 ft
Downstream Velocity	0.00 ft/s
Upstream Velocity	0.00 ft/s
Normal Depth	9.5 in
Critical Depth	8.0 in
Channel Slope	0.008 ft/ft
Critical Slope	0.020 ft/ft

East Swale - Southern Portion

Project Description	
Friction Method	Manning Formula
Solve For	Normal Depth

Input Data	
Roughness Coefficient	0.030
Channel Slope	0.008 ft/ft
Left Side Slope	4.000 H:V
Right Side Slope	4.000 H:V
Discharge	9.60 cfs

Results	
Normal Depth	11.4 in
Flow Area	3.6 ft ²
Wetted Perimeter	7.9 ft
Hydraulic Radius	5.5 in
Top Width	7.62 ft
Critical Depth	9.8 in
Critical Slope	0.018 ft/ft
Velocity	2.65 ft/s
Velocity Head	0.11 ft
Specific Energy	1.06 ft
Froude Number	0.677
Flow Type	Subcritical

GVF Input Data	
Downstream Depth	0.0 in
Length	0.0 ft
Number Of Steps	0

GVF Output Data	
Upstream Depth	0.0 in
Profile Description	N/A
Profile Headloss	0.00 ft
Downstream Velocity	0.00 ft/s
Upstream Velocity	0.00 ft/s
Normal Depth	11.4 in
Critical Depth	9.8 in
Channel Slope	0.008 ft/ft
Critical Slope	0.018 ft/ft

Appendix G – Soil Resource Report



United States
Department of
Agriculture

NRCS

Natural
Resources
Conservation
Service

A product of the National
Cooperative Soil Survey,
a joint effort of the United
States Department of
Agriculture and other
Federal agencies, State
agencies including the
Agricultural Experiment
Stations, and local
participants

Custom Soil Resource Report for El Paso County Area, Colorado

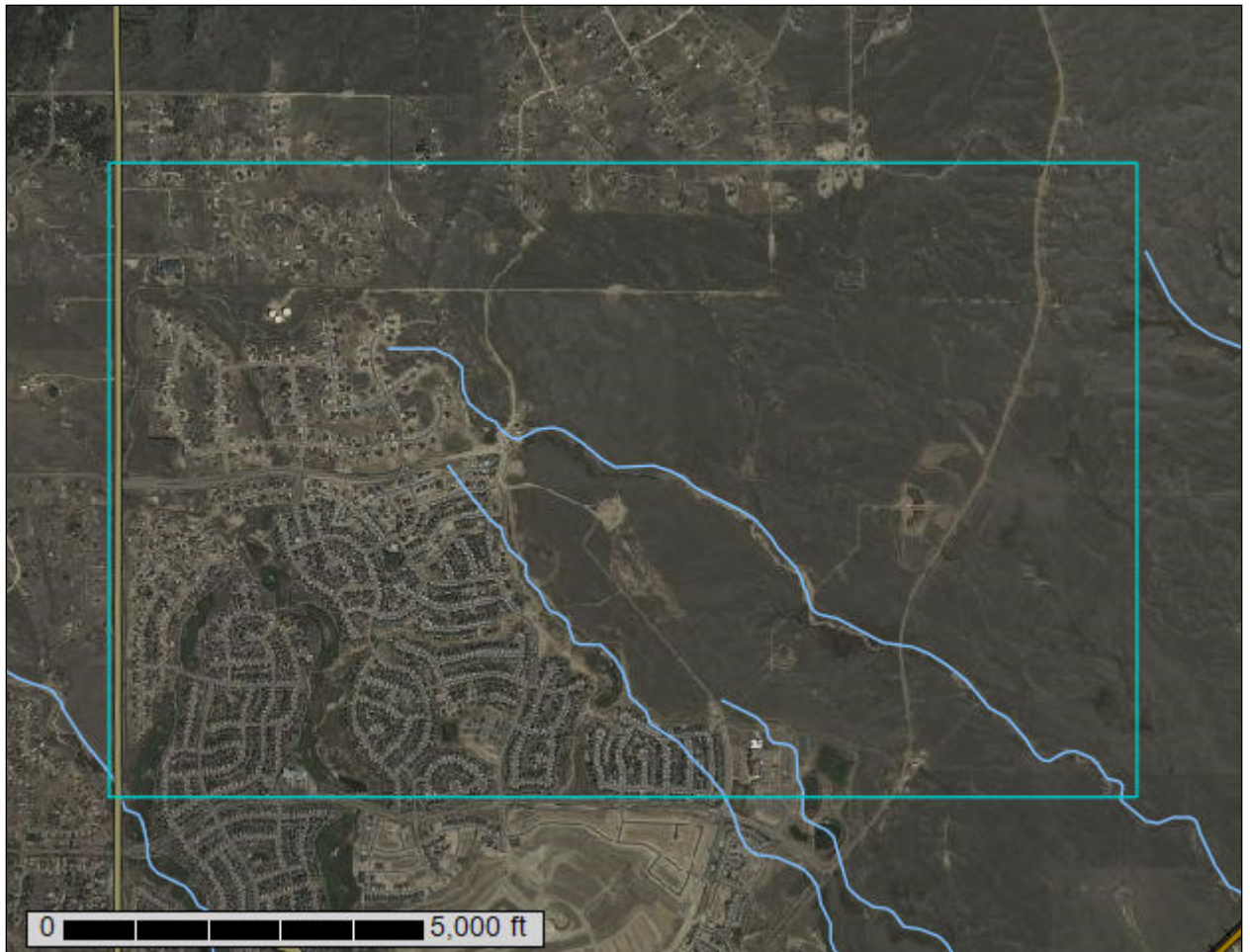

Preface

Soil surveys contain information that affects land use planning in survey areas. They highlight soil limitations that affect various land uses and provide information about the properties of the soils in the survey areas. Soil surveys are designed for many different users, including farmers, ranchers, foresters, agronomists, urban planners, community officials, engineers, developers, builders, and home buyers. Also, conservationists, teachers, students, and specialists in recreation, waste disposal, and pollution control can use the surveys to help them understand, protect, or enhance the environment.

Various land use regulations of Federal, State, and local governments may impose special restrictions on land use or land treatment. Soil surveys identify soil properties that are used in making various land use or land treatment decisions. The information is intended to help the land users identify and reduce the effects of soil limitations on various land uses. The landowner or user is responsible for identifying and complying with existing laws and regulations.

Although soil survey information can be used for general farm, local, and wider area planning, onsite investigation is needed to supplement this information in some cases. Examples include soil quality assessments (<http://www.nrcs.usda.gov/wps/portal/nrcs/main/soils/health/>) and certain conservation and engineering applications. For more detailed information, contact your local USDA Service Center (<https://offices.sc.egov.usda.gov/locator/app?agency=nrcs>) or your NRCS State Soil Scientist (http://www.nrcs.usda.gov/wps/portal/nrcs/detail/soils/contactus/?cid=nrcs142p2_053951).

Great differences in soil properties can occur within short distances. Some soils are seasonally wet or subject to flooding. Some are too unstable to be used as a foundation for buildings or roads. Clayey or wet soils are poorly suited to use as septic tank absorption fields. A high water table makes a soil poorly suited to basements or underground installations.

The National Cooperative Soil Survey is a joint effort of the United States Department of Agriculture and other Federal agencies, State agencies including the Agricultural Experiment Stations, and local agencies. The Natural Resources Conservation Service (NRCS) has leadership for the Federal part of the National Cooperative Soil Survey.

Information about soils is updated periodically. Updated information is available through the NRCS Web Soil Survey, the site for official soil survey information.

The U.S. Department of Agriculture (USDA) prohibits discrimination in all its programs and activities on the basis of race, color, national origin, age, disability, and where applicable, sex, marital status, familial status, parental status, religion, sexual orientation, genetic information, political beliefs, reprisal, or because all or a part of an individual's income is derived from any public assistance program. (Not all prohibited bases apply to all programs.) Persons with disabilities who require

alternative means for communication of program information (Braille, large print, audiotape, etc.) should contact USDA's TARGET Center at (202) 720-2600 (voice and TDD). To file a complaint of discrimination, write to USDA, Director, Office of Civil Rights, 1400 Independence Avenue, S.W., Washington, D.C. 20250-9410 or call (800) 795-3272 (voice) or (202) 720-6382 (TDD). USDA is an equal opportunity provider and employer.

Contents

Preface	2
How Soil Surveys Are Made	5
Soil Map	8
Soil Map.....	9
Legend.....	10
Map Unit Legend.....	11
Map Unit Descriptions.....	11
El Paso County Area, Colorado.....	13
19—Columbine gravelly sandy loam, 0 to 3 percent slopes.....	13
71—Pring coarse sandy loam, 3 to 8 percent slopes.....	14
83—Stapleton sandy loam, 3 to 8 percent slopes.....	15
References	17

How Soil Surveys Are Made

Soil surveys are made to provide information about the soils and miscellaneous areas in a specific area. They include a description of the soils and miscellaneous areas and their location on the landscape and tables that show soil properties and limitations affecting various uses. Soil scientists observed the steepness, length, and shape of the slopes; the general pattern of drainage; the kinds of crops and native plants; and the kinds of bedrock. They observed and described many soil profiles. A soil profile is the sequence of natural layers, or horizons, in a soil. The profile extends from the surface down into the unconsolidated material in which the soil formed or from the surface down to bedrock. The unconsolidated material is devoid of roots and other living organisms and has not been changed by other biological activity.

Currently, soils are mapped according to the boundaries of major land resource areas (MLRAs). MLRAs are geographically associated land resource units that share common characteristics related to physiography, geology, climate, water resources, soils, biological resources, and land uses (USDA, 2006). Soil survey areas typically consist of parts of one or more MLRA.

The soils and miscellaneous areas in a survey area occur in an orderly pattern that is related to the geology, landforms, relief, climate, and natural vegetation of the area. Each kind of soil and miscellaneous area is associated with a particular kind of landform or with a segment of the landform. By observing the soils and miscellaneous areas in the survey area and relating their position to specific segments of the landform, a soil scientist develops a concept, or model, of how they were formed. Thus, during mapping, this model enables the soil scientist to predict with a considerable degree of accuracy the kind of soil or miscellaneous area at a specific location on the landscape.

Commonly, individual soils on the landscape merge into one another as their characteristics gradually change. To construct an accurate soil map, however, soil scientists must determine the boundaries between the soils. They can observe only a limited number of soil profiles. Nevertheless, these observations, supplemented by an understanding of the soil-vegetation-landscape relationship, are sufficient to verify predictions of the kinds of soil in an area and to determine the boundaries.

Soil scientists recorded the characteristics of the soil profiles that they studied. They noted soil color, texture, size and shape of soil aggregates, kind and amount of rock fragments, distribution of plant roots, reaction, and other features that enable them to identify soils. After describing the soils in the survey area and determining their properties, the soil scientists assigned the soils to taxonomic classes (units). Taxonomic classes are concepts. Each taxonomic class has a set of soil characteristics with precisely defined limits. The classes are used as a basis for comparison to classify soils systematically. Soil taxonomy, the system of taxonomic classification used in the United States, is based mainly on the kind and character of soil properties and the arrangement of horizons within the profile. After the soil

Custom Soil Resource Report

scientists classified and named the soils in the survey area, they compared the individual soils with similar soils in the same taxonomic class in other areas so that they could confirm data and assemble additional data based on experience and research.

The objective of soil mapping is not to delineate pure map unit components; the objective is to separate the landscape into landforms or landform segments that have similar use and management requirements. Each map unit is defined by a unique combination of soil components and/or miscellaneous areas in predictable proportions. Some components may be highly contrasting to the other components of the map unit. The presence of minor components in a map unit in no way diminishes the usefulness or accuracy of the data. The delineation of such landforms and landform segments on the map provides sufficient information for the development of resource plans. If intensive use of small areas is planned, onsite investigation is needed to define and locate the soils and miscellaneous areas.

Soil scientists make many field observations in the process of producing a soil map. The frequency of observation is dependent upon several factors, including scale of mapping, intensity of mapping, design of map units, complexity of the landscape, and experience of the soil scientist. Observations are made to test and refine the soil-landscape model and predictions and to verify the classification of the soils at specific locations. Once the soil-landscape model is refined, a significantly smaller number of measurements of individual soil properties are made and recorded. These measurements may include field measurements, such as those for color, depth to bedrock, and texture, and laboratory measurements, such as those for content of sand, silt, clay, salt, and other components. Properties of each soil typically vary from one point to another across the landscape.

Observations for map unit components are aggregated to develop ranges of characteristics for the components. The aggregated values are presented. Direct measurements do not exist for every property presented for every map unit component. Values for some properties are estimated from combinations of other properties.

While a soil survey is in progress, samples of some of the soils in the area generally are collected for laboratory analyses and for engineering tests. Soil scientists interpret the data from these analyses and tests as well as the field-observed characteristics and the soil properties to determine the expected behavior of the soils under different uses. Interpretations for all of the soils are field tested through observation of the soils in different uses and under different levels of management. Some interpretations are modified to fit local conditions, and some new interpretations are developed to meet local needs. Data are assembled from other sources, such as research information, production records, and field experience of specialists. For example, data on crop yields under defined levels of management are assembled from farm records and from field or plot experiments on the same kinds of soil.

Predictions about soil behavior are based not only on soil properties but also on such variables as climate and biological activity. Soil conditions are predictable over long periods of time, but they are not predictable from year to year. For example, soil scientists can predict with a fairly high degree of accuracy that a given soil will have a high water table within certain depths in most years, but they cannot predict that a high water table will always be at a specific level in the soil on a specific date.

After soil scientists located and identified the significant natural bodies of soil in the survey area, they drew the boundaries of these bodies on aerial photographs and

Custom Soil Resource Report

identified each as a specific map unit. Aerial photographs show trees, buildings, fields, roads, and rivers, all of which help in locating boundaries accurately.

Soil Map

The soil map section includes the soil map for the defined area of interest, a list of soil map units on the map and extent of each map unit, and cartographic symbols displayed on the map. Also presented are various metadata about data used to produce the map, and a description of each soil map unit.

Custom Soil Resource Report Soil Map

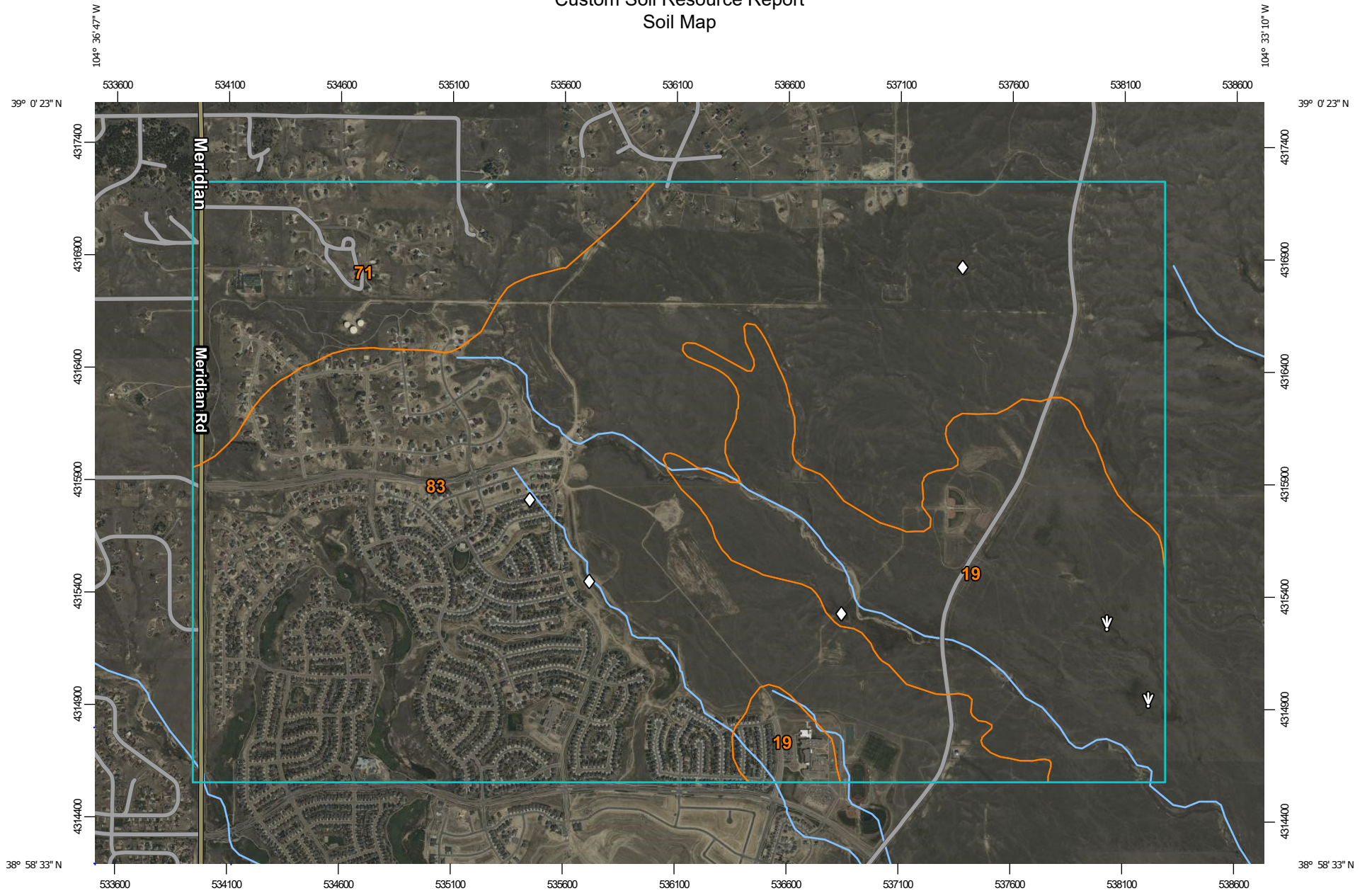

Map Scale: 1:23,900 if printed on A landscape (11" x 8.5") sheet.

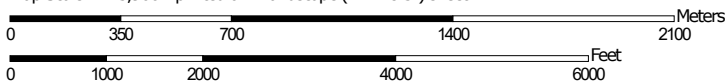

Map projection: Web Mercator Corner coordinates: WGS84 Edge tics: UTM Zone 13N WGS84



MAP LEGEND

Area of Interest (AOI)

 Area of Interest (AOI)

Soils







 Soil Map Unit Polygons

 Soil Map Unit Lines

 Soil Map Unit Points

Special Point Features





-  Blowout
-  Borrow Pit
-  Clay Spot
-  Closed Depression
-  Gravel Pit
-  Gravelly Spot
-  Landfill
-  Lava Flow
-  Marsh or swamp
-  Mine or Quarry
-  Miscellaneous Water
-  Perennial Water
-  Rock Outcrop
-  Saline Spot
-  Sandy Spot
-  Severely Eroded Spot
-  Sinkhole
-  Slide or Slip
-  Sodic Spot

-  Spoil Area
-  Stony Spot
-  Very Stony Spot
-  Wet Spot
-  Other
-  Special Line Features

Water Features

 Streams and Canals

Transportation

-  Rails
-  Interstate Highways
-  US Routes
-  Major Roads
-  Local Roads

Background

 Aerial Photography

MAP INFORMATION

The soil surveys that comprise your AOI were mapped at 1:24,000.

Please rely on the bar scale on each map sheet for map measurements.

Source of Map: Natural Resources Conservation Service
 Web Soil Survey URL:
 Coordinate System: Web Mercator (EPSG:3857)

Maps from the Web Soil Survey are based on the Web Mercator projection, which preserves direction and shape but distorts distance and area. A projection that preserves area, such as the Albers equal-area conic projection, should be used if more accurate calculations of distance or area are required.

This product is generated from the USDA-NRCS certified data as of the version date(s) listed below.

Soil Survey Area: El Paso County Area, Colorado
 Survey Area Data: Version 19, Aug 31, 2021

Soil map units are labeled (as space allows) for map scales 1:50,000 or larger.

Date(s) aerial images were photographed: Sep 11, 2018—Oct 20, 2018

The orthophoto or other base map on which the soil lines were compiled and digitized probably differs from the background imagery displayed on these maps. As a result, some minor shifting of map unit boundaries may be evident.

Map Unit Legend

Map Unit Symbol	Map Unit Name	Acres in AOI	Percent of AOI
19	Columbine gravelly sandy loam, 0 to 3 percent slopes	575.5	20.0%
71	Pring coarse sandy loam, 3 to 8 percent slopes	339.8	11.8%
83	Stapleton sandy loam, 3 to 8 percent slopes	1,964.3	68.2%
Totals for Area of Interest		2,879.9	100.0%

Map Unit Descriptions

The map units delineated on the detailed soil maps in a soil survey represent the soils or miscellaneous areas in the survey area. The map unit descriptions, along with the maps, can be used to determine the composition and properties of a unit.

A map unit delineation on a soil map represents an area dominated by one or more major kinds of soil or miscellaneous areas. A map unit is identified and named according to the taxonomic classification of the dominant soils. Within a taxonomic class there are precisely defined limits for the properties of the soils. On the landscape, however, the soils are natural phenomena, and they have the characteristic variability of all natural phenomena. Thus, the range of some observed properties may extend beyond the limits defined for a taxonomic class. Areas of soils of a single taxonomic class rarely, if ever, can be mapped without including areas of other taxonomic classes. Consequently, every map unit is made up of the soils or miscellaneous areas for which it is named and some minor components that belong to taxonomic classes other than those of the major soils.

Most minor soils have properties similar to those of the dominant soil or soils in the map unit, and thus they do not affect use and management. These are called noncontrasting, or similar, components. They may or may not be mentioned in a particular map unit description. Other minor components, however, have properties and behavioral characteristics divergent enough to affect use or to require different management. These are called contrasting, or dissimilar, components. They generally are in small areas and could not be mapped separately because of the scale used. Some small areas of strongly contrasting soils or miscellaneous areas are identified by a special symbol on the maps. If included in the database for a given area, the contrasting minor components are identified in the map unit descriptions along with some characteristics of each. A few areas of minor components may not have been observed, and consequently they are not mentioned in the descriptions, especially where the pattern was so complex that it was impractical to make enough observations to identify all the soils and miscellaneous areas on the landscape.

The presence of minor components in a map unit in no way diminishes the usefulness or accuracy of the data. The objective of mapping is not to delineate pure taxonomic classes but rather to separate the landscape into landforms or

Custom Soil Resource Report

landform segments that have similar use and management requirements. The delineation of such segments on the map provides sufficient information for the development of resource plans. If intensive use of small areas is planned, however, onsite investigation is needed to define and locate the soils and miscellaneous areas.

An identifying symbol precedes the map unit name in the map unit descriptions. Each description includes general facts about the unit and gives important soil properties and qualities.

Soils that have profiles that are almost alike make up a *soil series*. Except for differences in texture of the surface layer, all the soils of a series have major horizons that are similar in composition, thickness, and arrangement.

Soils of one series can differ in texture of the surface layer, slope, stoniness, salinity, degree of erosion, and other characteristics that affect their use. On the basis of such differences, a soil series is divided into *soil phases*. Most of the areas shown on the detailed soil maps are phases of soil series. The name of a soil phase commonly indicates a feature that affects use or management. For example, Alpha silt loam, 0 to 2 percent slopes, is a phase of the Alpha series.

Some map units are made up of two or more major soils or miscellaneous areas. These map units are complexes, associations, or undifferentiated groups.

A *complex* consists of two or more soils or miscellaneous areas in such an intricate pattern or in such small areas that they cannot be shown separately on the maps. The pattern and proportion of the soils or miscellaneous areas are somewhat similar in all areas. Alpha-Beta complex, 0 to 6 percent slopes, is an example.

An *association* is made up of two or more geographically associated soils or miscellaneous areas that are shown as one unit on the maps. Because of present or anticipated uses of the map units in the survey area, it was not considered practical or necessary to map the soils or miscellaneous areas separately. The pattern and relative proportion of the soils or miscellaneous areas are somewhat similar. Alpha-Beta association, 0 to 2 percent slopes, is an example.

An *undifferentiated group* is made up of two or more soils or miscellaneous areas that could be mapped individually but are mapped as one unit because similar interpretations can be made for use and management. The pattern and proportion of the soils or miscellaneous areas in a mapped area are not uniform. An area can be made up of only one of the major soils or miscellaneous areas, or it can be made up of all of them. Alpha and Beta soils, 0 to 2 percent slopes, is an example.

Some surveys include *miscellaneous areas*. Such areas have little or no soil material and support little or no vegetation. Rock outcrop is an example.

El Paso County Area, Colorado

19—Columbine gravelly sandy loam, 0 to 3 percent slopes

Map Unit Setting

National map unit symbol: 367p
Elevation: 6,500 to 7,300 feet
Mean annual precipitation: 14 to 16 inches
Mean annual air temperature: 46 to 50 degrees F
Frost-free period: 125 to 145 days
Farmland classification: Not prime farmland

Map Unit Composition

Columbine and similar soils: 97 percent
Minor components: 3 percent
Estimates are based on observations, descriptions, and transects of the mapunit.

Description of Columbine

Setting

Landform: Flood plains, fan terraces, fans
Down-slope shape: Linear
Across-slope shape: Linear
Parent material: Alluvium

Typical profile

A - 0 to 14 inches: gravelly sandy loam
C - 14 to 60 inches: very gravelly loamy sand

Properties and qualities

Slope: 0 to 3 percent
Depth to restrictive feature: More than 80 inches
Drainage class: Well drained
Runoff class: Very low
Capacity of the most limiting layer to transmit water (Ksat): High to very high (5.95 to 19.98 in/hr)
Depth to water table: More than 80 inches
Frequency of flooding: None
Frequency of ponding: None
Available water supply, 0 to 60 inches: Very low (about 2.5 inches)

Interpretive groups

Land capability classification (irrigated): 4e
Land capability classification (nonirrigated): 6e
Hydrologic Soil Group: A
Ecological site: R049XY214CO - Gravelly Foothill
Hydric soil rating: No

Minor Components

Fluvaquentic haplaquolls

Percent of map unit: 1 percent
Landform: Swales
Hydric soil rating: Yes

Other soils

Percent of map unit: 1 percent
Hydric soil rating: No

Pleasant

Percent of map unit: 1 percent
Landform: Depressions
Hydric soil rating: Yes

71—Pring coarse sandy loam, 3 to 8 percent slopes

Map Unit Setting

National map unit symbol: 369k
Elevation: 6,800 to 7,600 feet
Farmland classification: Not prime farmland

Map Unit Composition

Pring and similar soils: 85 percent
Estimates are based on observations, descriptions, and transects of the mapunit.

Description of Pring

Setting

Landform: Hills
Landform position (three-dimensional): Side slope
Down-slope shape: Linear
Across-slope shape: Linear
Parent material: Arkosic alluvium derived from sedimentary rock

Typical profile

A - 0 to 14 inches: coarse sandy loam
C - 14 to 60 inches: gravelly sandy loam

Properties and qualities

Slope: 3 to 8 percent
Depth to restrictive feature: More than 80 inches
Drainage class: Well drained
Runoff class: Low
Capacity of the most limiting layer to transmit water (Ksat): High (2.00 to 6.00 in/hr)
Depth to water table: More than 80 inches
Frequency of flooding: None
Frequency of ponding: None
Available water supply, 0 to 60 inches: Low (about 6.0 inches)

Interpretive groups

Land capability classification (irrigated): None specified
Land capability classification (nonirrigated): 3e
Hydrologic Soil Group: B
Ecological site: R048AY222CO - Loamy Park
Hydric soil rating: No

Minor Components

Pleasant

Percent of map unit:
Landform: Depressions
Hydric soil rating: Yes

Other soils

Percent of map unit:
Hydric soil rating: No

83—Stapleton sandy loam, 3 to 8 percent slopes

Map Unit Setting

National map unit symbol: 369z
Elevation: 6,500 to 7,300 feet
Mean annual precipitation: 14 to 16 inches
Mean annual air temperature: 46 to 48 degrees F
Frost-free period: 125 to 145 days
Farmland classification: Not prime farmland

Map Unit Composition

Stapleton and similar soils: 97 percent
Minor components: 3 percent
Estimates are based on observations, descriptions, and transects of the mapunit.

Description of Stapleton

Setting

Landform: Hills
Landform position (three-dimensional): Side slope
Down-slope shape: Linear
Across-slope shape: Linear
Parent material: Sandy alluvium derived from arkose

Typical profile

A - 0 to 11 inches: sandy loam
Bw - 11 to 17 inches: gravelly sandy loam
C - 17 to 60 inches: gravelly loamy sand

Properties and qualities

Slope: 3 to 8 percent
Depth to restrictive feature: More than 80 inches
Drainage class: Well drained
Runoff class: Low
Capacity of the most limiting layer to transmit water (Ksat): High (2.00 to 6.00 in/hr)
Depth to water table: More than 80 inches
Frequency of flooding: None
Frequency of ponding: None

Custom Soil Resource Report

Available water supply, 0 to 60 inches: Low (about 4.7 inches)

Interpretive groups

Land capability classification (irrigated): None specified

Land capability classification (nonirrigated): 3e

Hydrologic Soil Group: B

Ecological site: R049XY214CO - Gravelly Foothill

Hydric soil rating: No

Minor Components

Fluvaquentic haplaquolls

Percent of map unit: 1 percent

Landform: Swales

Hydric soil rating: Yes

Other soils

Percent of map unit: 1 percent

Hydric soil rating: No

Pleasant

Percent of map unit: 1 percent

Landform: Depressions

Hydric soil rating: Yes

References

- American Association of State Highway and Transportation Officials (AASHTO). 2004. Standard specifications for transportation materials and methods of sampling and testing. 24th edition.
- American Society for Testing and Materials (ASTM). 2005. Standard classification of soils for engineering purposes. ASTM Standard D2487-00.
- Cowardin, L.M., V. Carter, F.C. Golet, and E.T. LaRoe. 1979. Classification of wetlands and deep-water habitats of the United States. U.S. Fish and Wildlife Service FWS/OBS-79/31.
- Federal Register. July 13, 1994. Changes in hydric soils of the United States.
- Federal Register. September 18, 2002. Hydric soils of the United States.
- Hurt, G.W., and L.M. Vasilas, editors. Version 6.0, 2006. Field indicators of hydric soils in the United States.
- National Research Council. 1995. Wetlands: Characteristics and boundaries.
- Soil Survey Division Staff. 1993. Soil survey manual. Soil Conservation Service. U.S. Department of Agriculture Handbook 18. http://www.nrcs.usda.gov/wps/portal/nrcs/detail/national/soils/?cid=nrcs142p2_054262
- Soil Survey Staff. 1999. Soil taxonomy: A basic system of soil classification for making and interpreting soil surveys. 2nd edition. Natural Resources Conservation Service, U.S. Department of Agriculture Handbook 436. http://www.nrcs.usda.gov/wps/portal/nrcs/detail/national/soils/?cid=nrcs142p2_053577
- Soil Survey Staff. 2010. Keys to soil taxonomy. 11th edition. U.S. Department of Agriculture, Natural Resources Conservation Service. http://www.nrcs.usda.gov/wps/portal/nrcs/detail/national/soils/?cid=nrcs142p2_053580
- Tiner, R.W., Jr. 1985. Wetlands of Delaware. U.S. Fish and Wildlife Service and Delaware Department of Natural Resources and Environmental Control, Wetlands Section.
- United States Army Corps of Engineers, Environmental Laboratory. 1987. Corps of Engineers wetlands delineation manual. Waterways Experiment Station Technical Report Y-87-1.
- United States Department of Agriculture, Natural Resources Conservation Service. National forestry manual. http://www.nrcs.usda.gov/wps/portal/nrcs/detail/soils/home/?cid=nrcs142p2_053374
- United States Department of Agriculture, Natural Resources Conservation Service. National range and pasture handbook. <http://www.nrcs.usda.gov/wps/portal/nrcs/detail/national/landuse/rangepasture/?cid=stelprdb1043084>

Custom Soil Resource Report

United States Department of Agriculture, Natural Resources Conservation Service. National soil survey handbook, title 430-VI. http://www.nrcs.usda.gov/wps/portal/nrcs/detail/soils/scientists/?cid=nrcs142p2_054242

United States Department of Agriculture, Natural Resources Conservation Service. 2006. Land resource regions and major land resource areas of the United States, the Caribbean, and the Pacific Basin. U.S. Department of Agriculture Handbook 296. http://www.nrcs.usda.gov/wps/portal/nrcs/detail/national/soils/?cid=nrcs142p2_053624

United States Department of Agriculture, Soil Conservation Service. 1961. Land capability classification. U.S. Department of Agriculture Handbook 210. http://www.nrcs.usda.gov/Internet/FSE_DOCUMENTS/nrcs142p2_052290.pdf

Appendix H – Drainage Maps

THE SANCTUARY - PDR/FDR

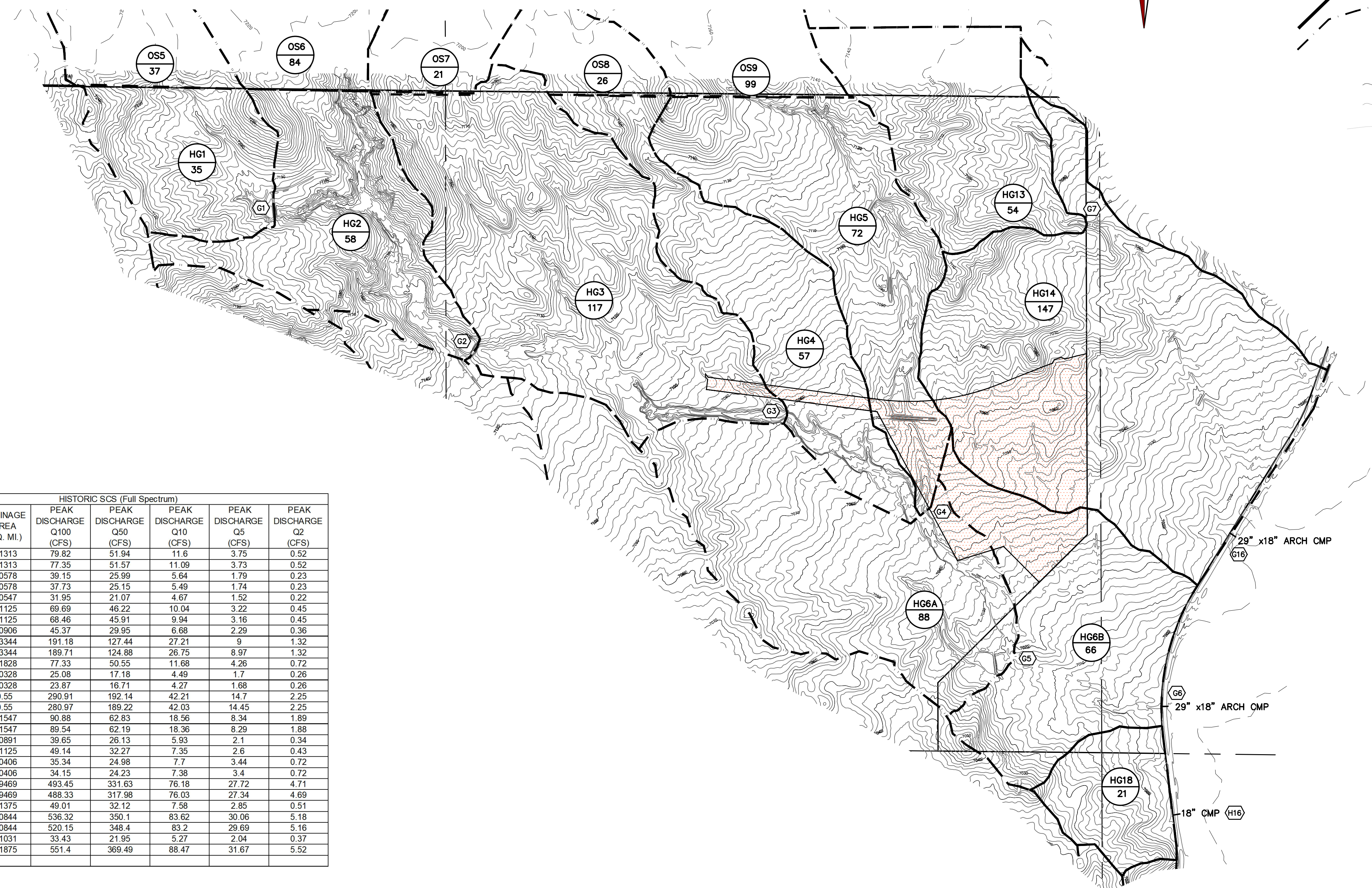
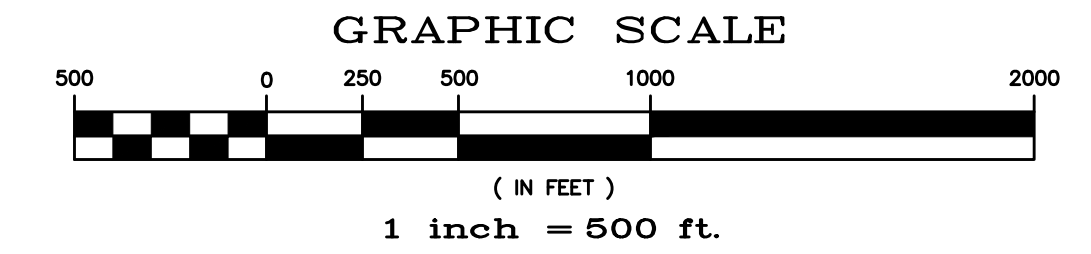

LEGEND

- MAJOR BASIN BOUNDARY
- MINOR BASIN BOUNDARY
- SCS MODEL ID **EB15**
- SIZE ACRES **65**
- DESIGN POINTS **(G1) (G2) (G3) (G4) (G5) (G6) (G7) (G10)**
- MAJOR CONTOUR INTERVAL
- MINOR CONTOUR INTERVAL
- 100 YEAR FLOOD PLAN

HYDROLOGIC ELEMENT	DRAINAGE AREA (SQ. MI.)	HISTORIC SCS (Full Spectrum)				
		PEAK DISCHARGE Q100 (CFS)	PEAK DISCHARGE Q50 (CFS)	PEAK DISCHARGE Q10 (CFS)	PEAK DISCHARGE Q5 (CFS)	PEAK DISCHARGE Q2 (CFS)
OS06	0.1313	79.82	51.94	11.6	3.75	0.52
OS06-G02	0.1313	77.35	51.57	11.09	3.73	0.52
OS05	0.0578	39.15	25.99	5.64	1.79	0.23
OS05-G01	0.0578	37.73	25.15	5.49	1.74	0.23
HG01	0.0547	31.95	21.07	4.67	1.52	0.22
G01	0.1125	69.69	46.22	10.04	3.22	0.45
G01-G02	0.1125	68.46	45.91	9.94	3.16	0.45
HG02	0.0906	45.37	29.95	6.68	2.29	0.36
G02	0.3344	191.18	127.44	27.21	9	1.32
G02-G03	0.3344	189.71	124.88	26.75	8.97	1.32
HG03	0.1828	77.33	50.55	11.68	4.26	0.72
OS07	0.0328	25.08	17.18	4.49	1.7	0.26
OS07-G03	0.0328	23.87	16.71	4.27	1.68	0.26
G03	0.55	290.91	192.14	42.21	14.7	2.25
G03-G04	0.55	280.97	189.22	42.03	14.45	2.25
OS09	0.1547	90.88	62.83	18.56	8.34	1.89
OS09-G04	0.1547	89.54	62.19	18.36	8.29	1.88
HG04	0.0891	39.65	26.13	5.93	2.1	0.34
HG05	0.1125	49.14	32.27	7.35	2.6	0.43
OS08	0.0406	35.34	24.98	7.7	3.44	0.72
OS08-G04	0.0406	34.15	24.23	7.38	3.4	0.72
G04	0.9469	493.45	331.63	76.18	27.72	4.71
G04-G05	0.9469	488.33	317.98	76.03	27.34	4.69
HG06A	0.1375	49.01	32.12	7.58	2.85	0.51
G05	1.0844	536.32	350.1	83.62	30.06	5.18
G05-G06	1.0844	520.15	348.4	83.2	29.69	5.16
HG06B	0.1031	33.43	21.95	5.27	2.04	0.37
G06	1.1875	551.4	369.49	88.47	31.67	5.52

HISTORIC CONDITIONS - SCS MAP

FIGURE 4

Scale AS SHOWN	Drawn by TAK	Checked by RA	Date MAY 2022	No.	Revisions	Date	Appr.	Date
				-	-	-	-	-
<p>HISTORIC CONDITIONS - SCS MAP THE SANCTUARY FILING 1 PUD - PDR</p>								
<p>MERIDIAN RANCH</p>								
<p>TECH CONTRACTORS 11886 STAPLETON DRIVE FALCON, CO 80831 TELEPHONE: 719.495.7444 FAX: 719.495.3349</p>								

S:\OneDrive\City\Rolling Hills Filing 4\DWG\Plan Sheets\DRAINAGE MAPS\PDR - FDR\THE SANCTUARY PDR - FDR - SCS - HIST.dwg, 4/25/2022 12:01:29 PM

*NOTE: PRELIMINARY STORAGE VOLUMES AND OUTFLOW QUANTITIES HAVE BEEN PROVIDED FOR EACH OF THE FUTURE DETENTION FACILITIES LOCATED WITHIN THE DEVELOPMENT. THE ACTUAL STORAGE VOLUMES AND DISCHARGE RATES WILL BE DETERMINED UPON A COMPLETE ANALYSIS FOR EACH DETENTION FACILITY PRIOR TO CONSTRUCTION. THE VALUES GIVEN FOR DISCHARGE AND VOLUME ARE ESTIMATES FOR PLANNING PURPOSES ONLY.

THE SANCTUARY FILING 1

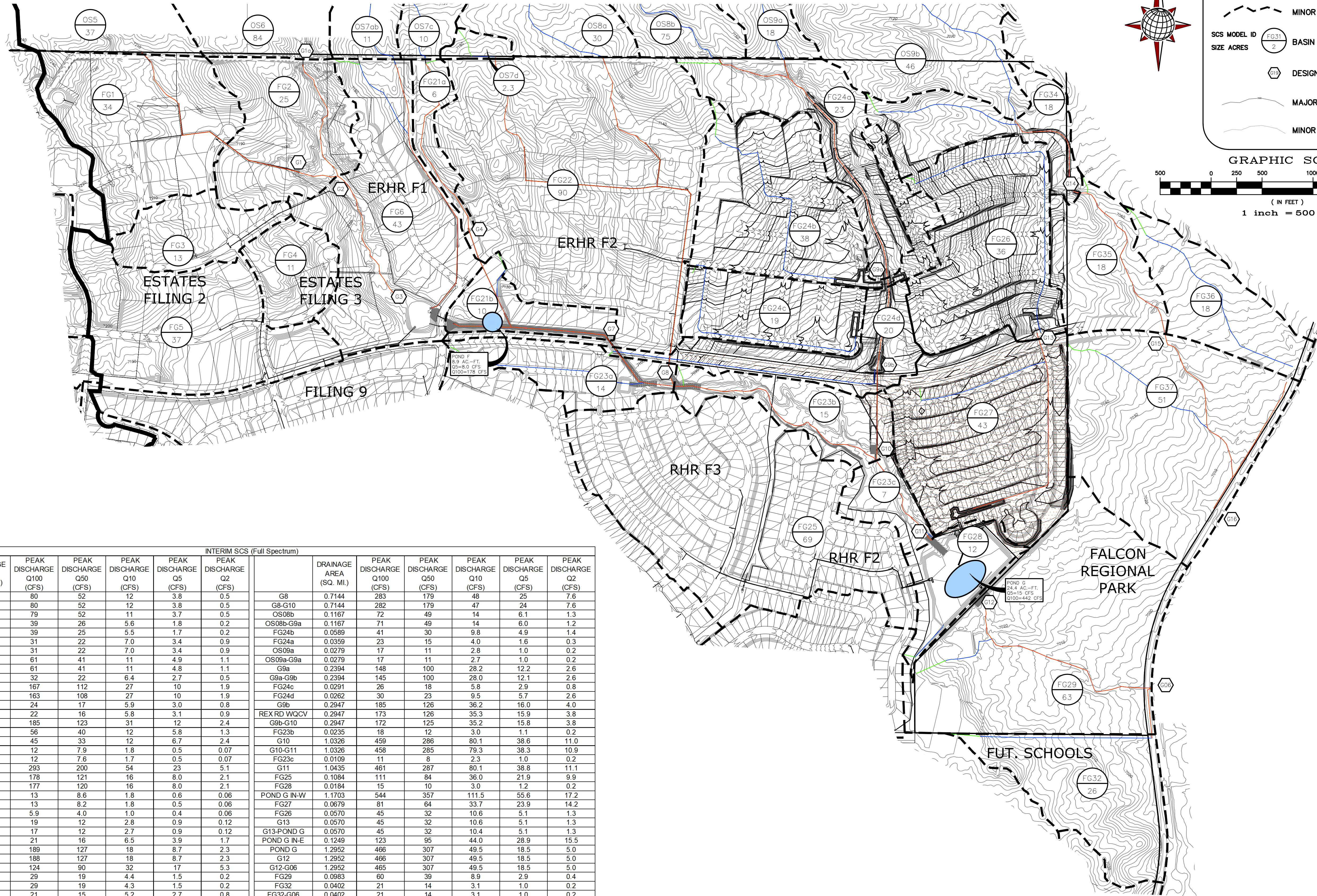

LEGEND

- MAJOR BASIN BOUNDARY
- MINOR BASIN BOUNDARY
- SCS MODEL ID (FG31) BASIN IDENTIFICATION
- SIZE ACRES (2) BASIN IDENTIFICATION
- DESIGN POINT
- MAJOR CONTOUR INTERVAL
- MINOR CONTOUR INTERVAL

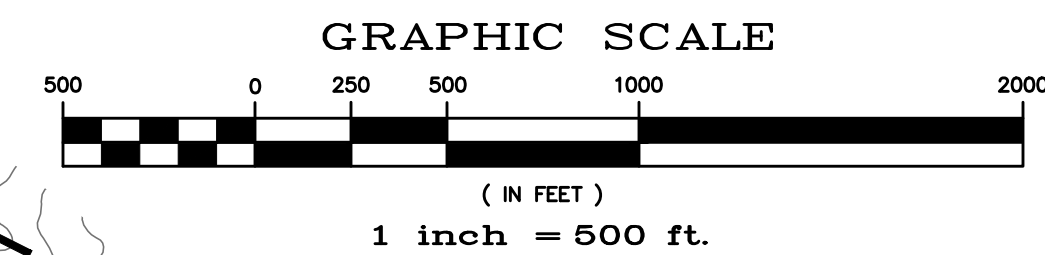

INTERIM SCS (Full Spectrum)													
	DRAINAGE AREA (SQ. MI.)	PEAK DISCHARGE Q100 (CFS)	PEAK DISCHARGE Q50 (CFS)	PEAK DISCHARGE Q10 (CFS)	PEAK DISCHARGE Q5 (CFS)	PEAK DISCHARGE Q2 (CFS)		DRAINAGE AREA (SQ. MI.)	PEAK DISCHARGE Q100 (CFS)	PEAK DISCHARGE Q50 (CFS)	PEAK DISCHARGE Q10 (CFS)	PEAK DISCHARGE Q5 (CFS)	PEAK DISCHARGE Q2 (CFS)
OS06	0.1313	80	52	12	3.8	0.5	G8	0.7144	283	179	48	25	7.6
G1a	0.1313	80	52	12	3.8	0.5	G8-G10	0.7144	282	179	47	24	7.6
G1a-G2	0.1313	79	52	11	3.7	0.5	OS08b	0.1167	72	49	14	6.1	1.3
OS05	0.0578	39	26	5.6	1.8	0.2	OS08b-G9a	0.1167	71	49	14	6.0	1.2
OS05-G1	0.0578	39	25	5.5	1.7	0.2	FG24b	0.0589	41	30	9.8	4.9	1.4
FG01	0.0538	31	22	7.0	3.4	0.9	FG24a	0.0359	23	15	4.0	1.6	0.3
FG01-G1	0.0538	31	22	7.0	3.4	0.9	OS09a	0.0279	17	11	2.8	1.0	0.2
G1	0.1116	61	41	11	4.9	1.1	OS09a-G9a	0.0279	17	11	2.7	1.0	0.2
G1-G2	0.1116	61	41	11	4.8	1.1	G9a	0.2394	148	100	28.2	12.2	2.6
FG02	0.0391	32	22	6.4	2.7	0.5	G9a-G9b	0.2394	145	100	28.0	12.1	2.6
G2	0.2820	167	112	27	10	1.9	FG24c	0.0291	26	18	5.8	2.9	0.8
G2-G3	0.2820	163	108	27	10	1.9	FG24d	0.0262	30	23	9.5	5.7	2.6
FG03	0.0203	24	17	5.9	3.0	0.8	G9b	0.2947	185	126	36.2	16.0	4.0
FG04	0.0172	22	16	5.8	3.1	0.9	REX RD WQCV	0.2947	173	126	35.3	15.9	3.8
G3	0.3195	185	123	31	12	2.4	G9b-G10	0.2947	172	125	35.2	15.8	3.8
FG06	0.0675	46	32	12	5.8	1.3	FG23b	0.0235	18	12	3.0	1.1	0.2
FG05	0.0580	45	33	12	6.7	2.4	G10	1.0326	459	286	80.1	38.6	11.0
OS07ab	0.0170	12	7.9	1.8	0.5	0.07	G10-G11	1.0326	458	285	79.3	38.3	10.9
OS07ab-POND F	0.0170	12	7.6	1.7	0.5	0.07	FG23c	0.0109	11	8	2.3	1.0	0.2
POND F IN	0.4620	293	200	54	23	5.1	G11	1.0435	461	287	80.1	38.8	11.1
POND F	0.4620	178	121	16	8.0	2.1	FG25	0.1084	111	84	36.0	21.9	9.9
POND F-G7	0.4620	177	120	16	8.0	2.1	FG28	0.0184	15	10	3.0	1.2	0.2
OS07c	0.0158	13	8.6	1.8	0.6	0.06	POND G IN-W	1.1703	544	357	111.5	55.6	17.2
OS07c-G4	0.0158	13	8.2	1.8	0.5	0.06	FG27	0.0679	81	64	33.7	23.9	14.2
FG21a	0.0095	5.9	4.0	1.0	0.4	0.06	FG26	0.0570	45	32	10.6	5.1	1.3
G4	0.0253	19	12	2.8	0.9	0.12	G13	0.0570	45	32	10.6	5.1	1.3
G4-G7	0.0253	17	12	2.7	0.9	0.12	G13-POND G	0.0570	45	32	10.4	5.1	1.3
FG21b	0.0150	21	16	6.5	3.9	1.7	POND G IN-E	0.1249	123	95	44.0	28.9	15.5
G7	0.5023	189	127	18	8.7	2.3	POND G	1.2952	466	307	49.5	18.5	5.0
G7-G8	0.5023	188	127	18	8.7	2.3	G12	1.2952	466	307	49.5	18.5	5.0
FG22	0.1400	124	90	32	17	5.3	G12-G06	1.2952	465	307	49.5	18.5	5.0
OS08a	0.0469	29	19	4.4	1.5	0.2	FG29	0.0983	60	39	8.9	2.9	0.4
OS08-G8	0.0469	29	19	4.3	1.5	0.2	FG32	0.0402	21	14	3.1	1.0	0.2
FG23a	0.0216	21	15	5.2	2.7	0.8	FG32-G06	0.0402	21	14	3.1	1.0	0.2
OS07d	0.0036	2.6	1.7	0.4	0.1	0.01	G06	1.4337	491	323	52.4	19.6	5.3
OS07d-G8	0.0036	2.6	1.7	0.4	0.1	0.01							

INTERIM CONDITIONS - SCS MAP

FIGURE 5

Scale	AS SHOWN	Drawn by	TAK	Checked by	Date	No.	Revisions	Date	Inst.	Appr.	Date
<p>TECH CONTRACTORS 11886 STAPLETON DRIVE FALCON, CO 80831 TELEPHONE: 719.495.7444 FAX: 719.495.3349</p> <p>MERIDIAN RANCH</p> <p>INTERIM CONDITIONS - SCS MAP THE SANCTUARY FILING 1 FDR - FDR</p> <p>MAY 2022</p>											

*NOTE: PRELIMINARY STORAGE VOLUMES AND OUTFLOW QUANTITIES HAVE BEEN PROVIDED FOR EACH OF THE FUTURE DETENTION FACILITIES LOCATED WITHIN THE DEVELOPMENT. THE ACTUAL STORAGE VOLUMES AND DISCHARGE RATES WILL BE DETERMINED UPON A COMPLETE ANALYSIS FOR EACH DETENTION FACILITY PRIOR TO CONSTRUCTION. THE VALUES GIVEN FOR DISCHARGE AND VOLUME ARE ESTIMATES FOR PLANNING PURPOSES ONLY.

THE SANCTUARY FILING 1

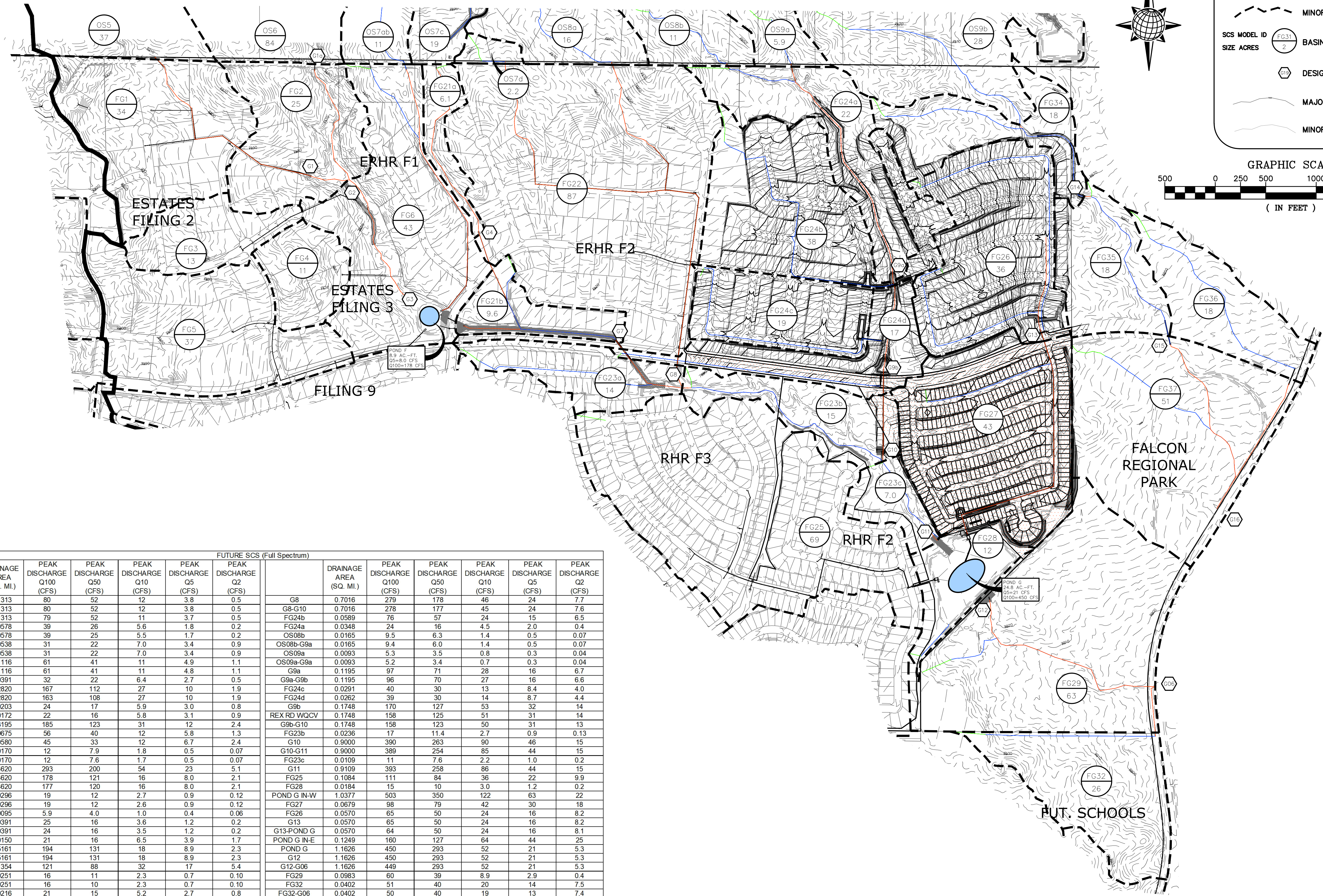

LEGEND

- MAJOR BASIN BOUNDARY
- MINOR BASIN BOUNDARY
- SCS MODEL ID: FG31
- SIZE ACRES: 2
- BASIN IDENTIFICATION
- DESIGN POINT
- MAJOR CONTOUR INTERVAL
- MINOR CONTOUR INTERVAL

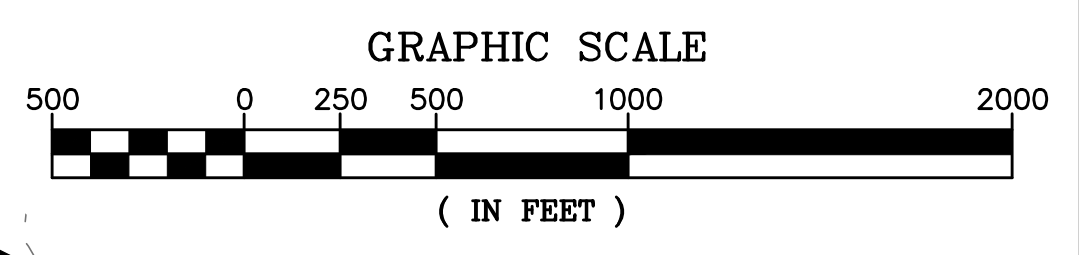

FUTURE SCS (Full Spectrum)													
	DRAINAGE AREA (SQ. MI.)	PEAK DISCHARGE Q100 (CFS)	PEAK DISCHARGE Q50 (CFS)	PEAK DISCHARGE Q10 (CFS)	PEAK DISCHARGE Q5 (CFS)	PEAK DISCHARGE Q2 (CFS)		DRAINAGE AREA (SQ. MI.)	PEAK DISCHARGE Q100 (CFS)	PEAK DISCHARGE Q50 (CFS)	PEAK DISCHARGE Q10 (CFS)	PEAK DISCHARGE Q5 (CFS)	PEAK DISCHARGE Q2 (CFS)
OS06	0.1313	80	52	12	3.8	0.5	G8	0.7016	279	178	46	24	7.7
G1a	0.1313	80	52	12	3.8	0.5	G8-G10	0.7016	278	177	45	24	7.6
G1a-G2	0.1313	79	52	11	3.7	0.5	FG24b	0.0589	76	57	24	15	6.5
OS05	0.0578	39	26	5.6	1.8	0.2	FG24a	0.0348	24	16	4.5	2.0	0.4
OS05-G1	0.0578	39	25	5.5	1.7	0.2	OS08b	0.0165	9.5	6.3	1.4	0.5	0.07
FG01	0.0538	31	22	7.0	3.4	0.9	OS08b-G9a	0.0165	9.4	6.0	1.4	0.5	0.07
FG01-G1	0.0538	31	22	7.0	3.4	0.9	OS09a	0.0093	5.3	3.5	0.8	0.3	0.04
G1	0.1116	61	41	11	4.9	1.1	OS09a-G9a	0.0093	5.2	3.4	0.7	0.3	0.04
G1-G2	0.1116	61	41	11	4.8	1.1	G9a	0.1195	97	71	28	16	6.7
FG02	0.0391	32	22	6.4	2.7	0.5	G9a-G9b	0.1195	96	70	27	16	6.6
G2	0.2820	167	112	27	10	1.9	FG24c	0.0291	40	30	13	8.4	4.0
G2-G3	0.2820	163	108	27	10	1.9	FG24d	0.0262	39	30	14	8.7	4.4
FG03	0.0203	24	17	5.9	3.0	0.8	G9b	0.1748	170	127	53	32	14
FG04	0.0172	22	16	5.8	3.1	0.9	REX RD WOCV	0.1748	158	125	51	31	14
G3	0.3195	185	123	31	12	2.4	G9b-G10	0.1748	158	123	50	31	13
FG06	0.0675	56	40	12	5.8	1.3	FG23b	0.0236	17	11.4	2.7	0.9	0.13
FG05	0.0580	45	33	12	6.7	2.4	G10	0.9000	390	263	90	46	15
OS07ab	0.0170	12	7.9	1.8	0.5	0.07	G10-G11	0.9000	389	254	85	44	15
OS07ab-POND F	0.0170	12	7.6	1.7	0.5	0.07	FG23c	0.0109	11	7.6	2.2	1.0	0.2
POND F IN	0.4620	293	200	54	23	5.1	G11	0.9109	393	258	86	44	15
POND F	0.4620	178	121	16	8.0	2.1	FG25	0.1084	111	84	36	22	9.9
POND F-G7	0.4620	177	120	16	8.0	2.1	FG28	0.0184	15	10	3.0	1.2	0.2
OS07c	0.0296	19	12	2.7	0.9	0.12	POND G IN-W	1.0377	503	350	122	63	22
OS07c-G4	0.0296	19	12	2.6	0.9	0.12	FG27	0.0679	98	79	42	30	18
FG21a	0.0095	5.9	4.0	1.0	0.4	0.06	FG26	0.0570	65	50	24	16	8.2
G4	0.0391	25	16	3.6	1.2	0.2	G13	0.0570	65	50	24	16	8.2
G4-G7	0.0391	24	16	3.5	1.2	0.2	G13-POND G	0.0570	64	50	24	16	8.1
FG21b	0.0150	21	16	6.5	3.9	1.7	POND G IN-E	0.1249	160	127	64	44	25
G7	0.5161	194	131	18	8.9	2.3	POND G	1.1626	450	293	52	21	5.3
G7-G8	0.5161	194	131	18	8.9	2.3	G12	1.1626	450	293	52	21	5.3
FG22	0.1354	121	88	32	17	5.4	G12-G06	1.1626	449	293	52	21	5.3
OS08a	0.0251	16	11	2.3	0.7	0.10	FG29	0.0983	60	39	8.9	2.9	0.4
OS08-G8	0.0251	16	10	2.3	0.7	0.10	FG32	0.0402	51	40	20	14	7.5
FG23a	0.0216	21	15	5.2	2.7	0.8	FG32-G06	0.0402	50	40	19	13	7.4
OS07d	0.0034	2.5	1.6	0.4	0.1	0.01	G06	1.3011	491	317	57	22	7.5
OS07d-G8	0.0034	2.4	1.6	0.3	0.1	0.01							

FUTURE CONDITIONS - SCS MAP

FIGURE 6

Scale	AS SHOWN	of	
Drawn by	TAK	Checked by	
Date		Date	MAY 2022
FUTURE CONDITIONS - SCS MAP			
THE SANCTUARY FILING 1			
FDR - FDR			
TECH CONTRACTORS 1.1910 TOURMALINE DR #130 FALCON, CO 80831 TELEPHONE: 719.495.7444			
No.		Revisions	
Date		Inst.	
Appr.			
Date			

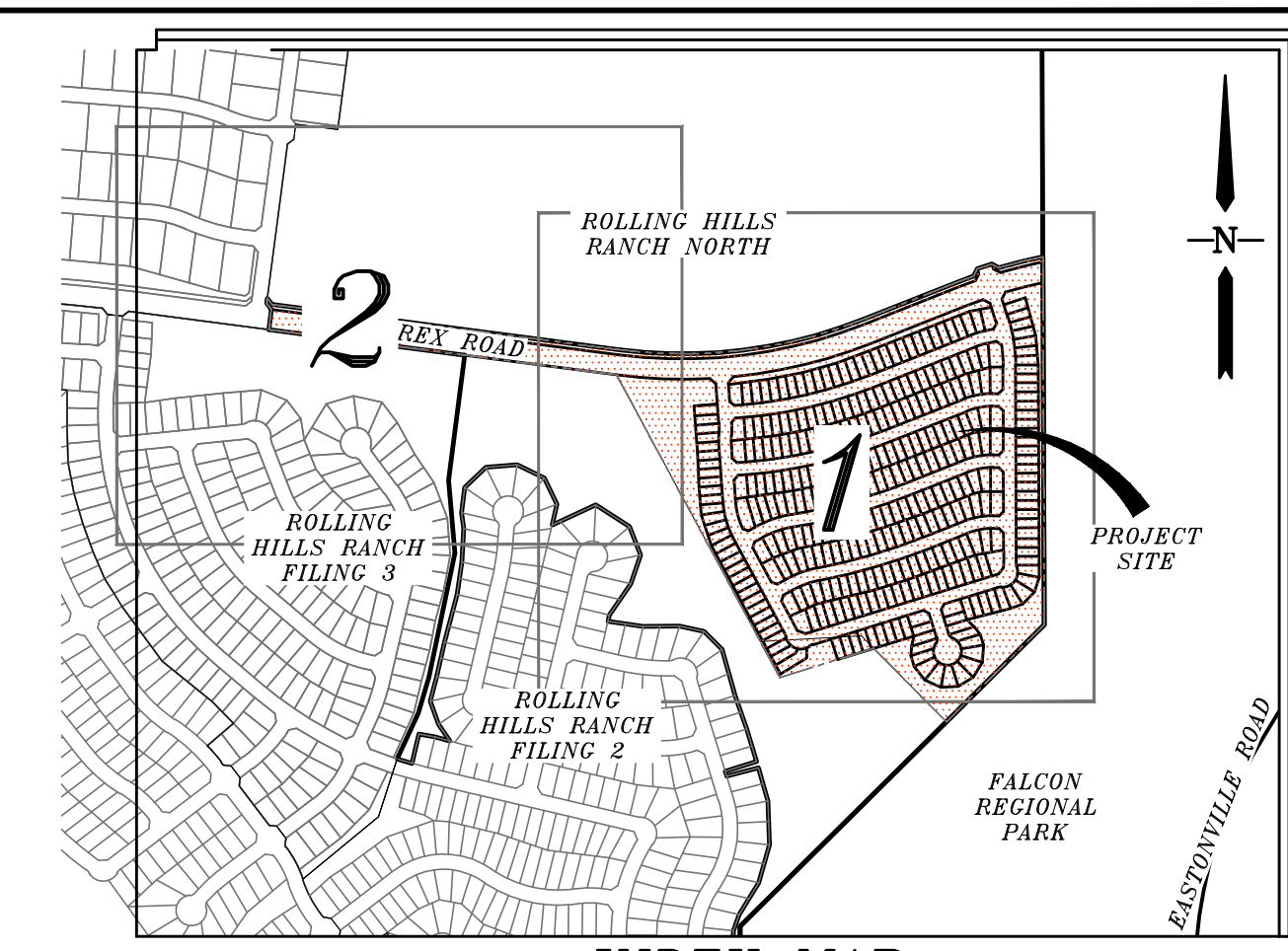
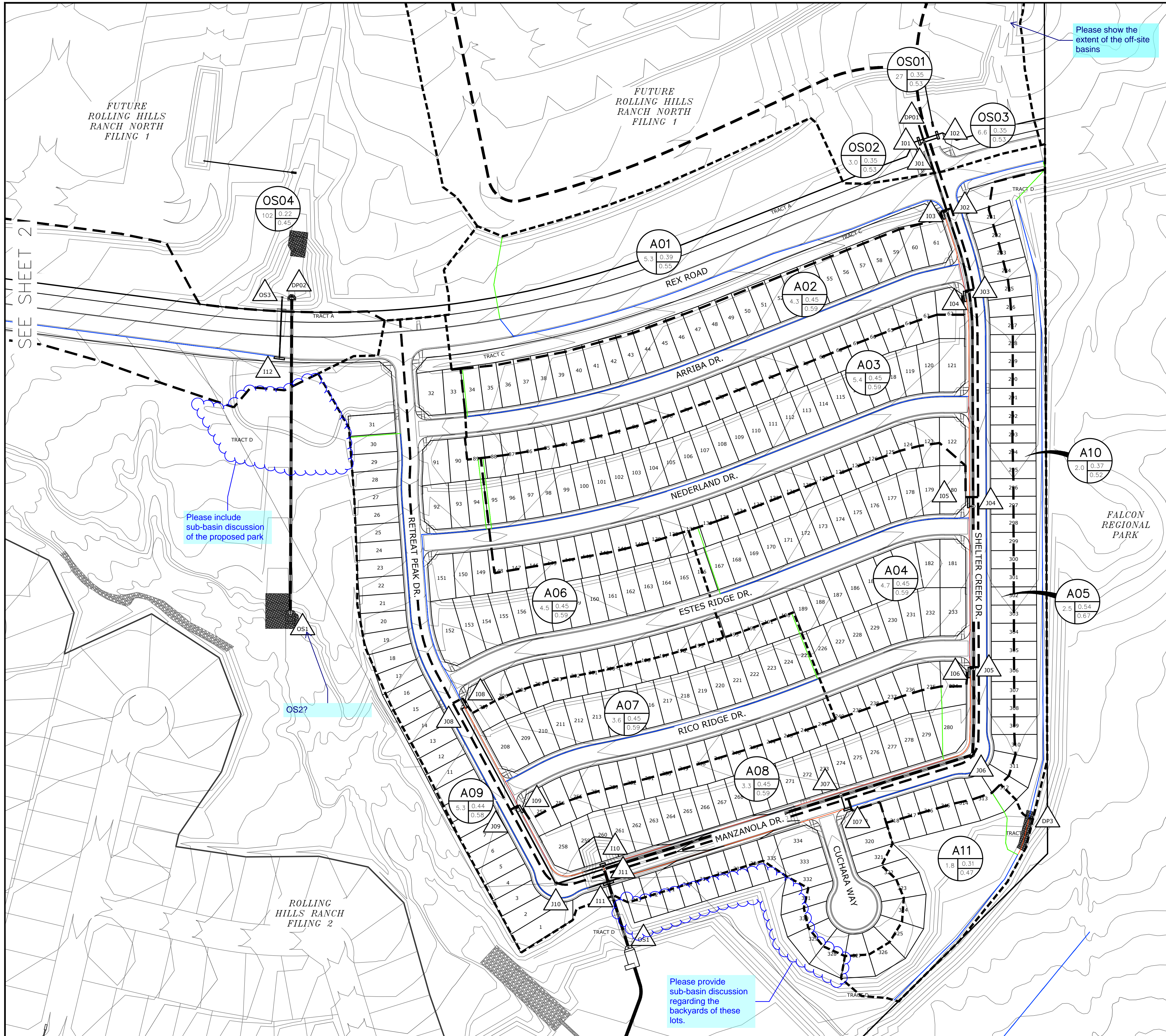

INDEX MAP
N.T.S.

- G01 BASIN DESIGNATION
- Sub-watershed Designation
- MINOR/MAJOR STORM COEFFICIENT
- 61 BASIN AREA IN ACRES
- 61 DESIGN POINT DESIGNATION
- MAJOR BASIN BOUNDARY
- SUB-BASIN BOUNDARY
- EXISTING CONTOUR
- PROPOSED CONTOUR
- PROPOSED STORM SEWER
- INITIAL OVERLAND TIME (Ti)
- TRAVEL TIME (Tt)
- OVERLAND TIME (To)

GRAPHIC SCALE
1 inch = 100 ft.

UPSTREAM DP	BASIN	AREA (AC)	Q(5) (CFS)	Q(100) (CFS)	INLET	Q(5) (CFS)	Q(100) (CFS)	PIPE
DP1	OS01	27	29	60		29	61	36" RCP
I01	OS02	3.0	3.6	19	PR 15" SUMP	3.6	19	18" RCP
I02	OS03	6.6	7.4	19	PR 15" SUMP	7.4	19	18" RCP
J01								38 93 42" RCP
I03	A01	5.3	6.9	17	PR 15" FLOW-BY	4.6	9	18" RCP
J02								42 100 42" RCP
I04	A02	4.3	8.6	22	PR 20" FLOW-BY	6.2	13	18" RCP
J03								47 112 48" RCP
I05	A03	5.5	9.8	24	PR 20" FLOW-BY	7.7	17	18" RCP
J04								53 126 54" RCP
I06	A04	4.7	8.0	21	PR 20" FLOW-BY	6.5	14	18" RCP
J05								59 138 54" RCP
J06								59 137 54" RCP
I07	A05	2.5	4.4	9	PR 15" FLOW-BY	3.7	7	18" RCP
J07								61 141 54" RCP
I08	A06	4.5	7.8	17	PR 20" FLOW-BY	5.7	11	18" RCP
J08								5.7 11 18" RCP
I09	A07	3.6	7.7	18	PR 15" FLOW-BY	5.4	11	24" RCP
J09								11 22 24" RCP
J10								11 21 24" RCP
I10	A08	3.3	6.2	18	PR 10" SUMP	6.2	14	18" RCP
J11								66 150 54" RCP
I11	A09	5.3	7.9	18	PR 20" SUMP	7.4	168	54" RCP
	A10	2.0	2.5	5.8	SWALE	2.5	5.8	
DP3	A11	1.8	2.1	5.2	SWALE	3.9	9.6	
I12	A12	9.9	15	34	PR 20" SUMP	15	34	24" RCP
DP02	OS04	102	46	158		46	159	54" RCP

BENCH MARK:
INTERSECTION OF WOODMEN RD AND MERIDIAN ROAD AT SW CORNER (BRASS CAP W/ NO. GF-9)
ELEVATION = 6874.00

NOTE:
COUNTY PLAN REVIEW IS PROVIDED ONLY FOR GENERAL CONFORMANCE WITH COUNTY DESIGN CRITERIA. THE COUNTY IS NOT RESPONSIBLE FOR THE ACCURACY AND ADEQUACY OF THE DESIGN, DIMENSIONS, AND/OR ELEVATIONS WHICH SHALL BE CONFIRMED AT THE JOB SITE. THE COUNTY THROUGH THE APPROVAL OF THIS DOCUMENT ASSUMES NO RESPONSIBILITY FOR THE COMPLETENESS AND/OR ACCURACY OF THIS DOCUMENT.

SEE SHEET 21

Please include sub-basin discussion of the proposed park

Please show the extent of the off-site basins

Please provide sub-basin discussion regarding the backyards of these lots.

TECH CONTRACTORS 11886 STAPLETON DRIVE FALCON, CO 80831 TELEPHONE: 719.495.7444 FAX: 719.495.3349	
MERIDIAN RANCH	
RATIONAL DRAINAGE MAP FINAL DRAINAGE REPORT THE SANCTUARY FILING 1 AT MERIDIAN RANCH	
Drawn by TAK	Checked by -
Scale 1" = 100'	Date MAY 2022
1 of 2	2
No.	Revisions
Date	Inst.
Date	Appr.
Date	Date

FIGURE 7

S:\OneDrive\Civil\Rolling Hills Filing 4\DWG\Plan Sheets\DRAINAGE MAPS\DR - FDR\SANCTUARY FILING 1 FOR RATIONAL MAP.dwg, 4/18/2022 1:59:59 PM

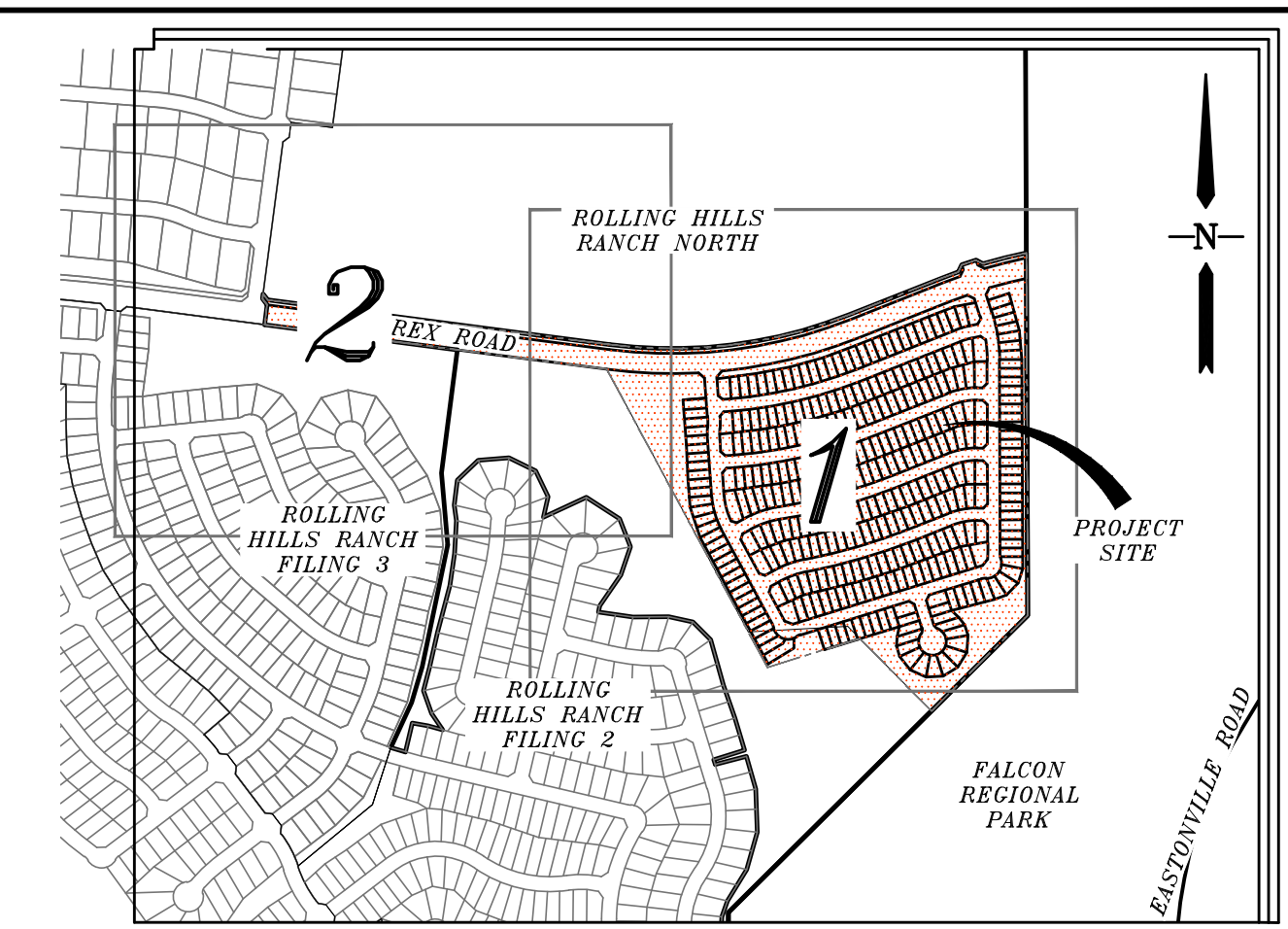
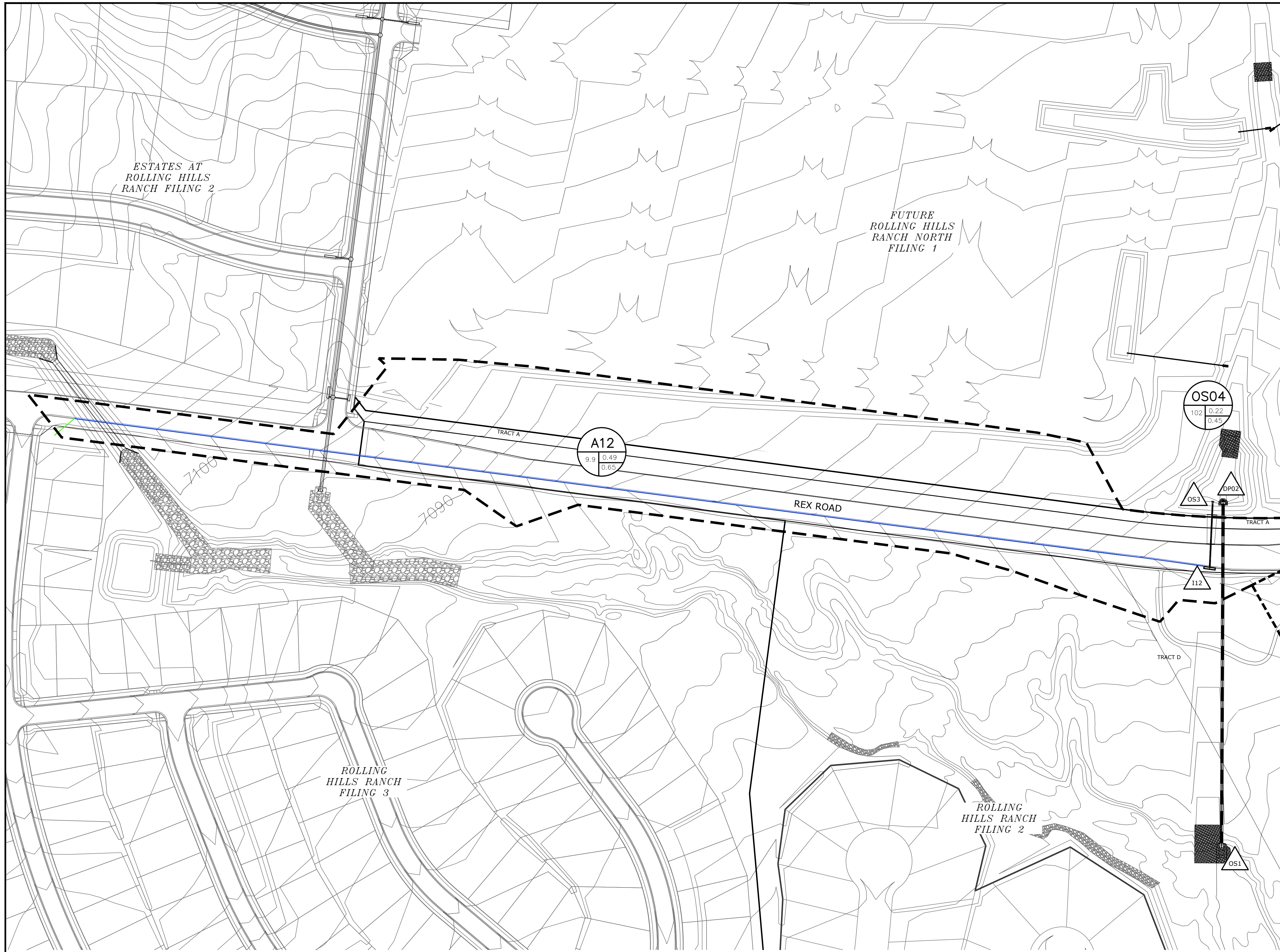

INDEX MAP
N.T.S.

- G01 BASIN DESIGNATION
- 2.7 0.40
0.56 SUB-WATERSHED DESIGNATION
- 9.9 0.49
0.65 MINOR/MAJOR STORM COEFFICIENT
- 102 0.22
0.45 BASIN AREA IN ACRES
- 61 DESIGN POINT DESIGNATION
- MAJOR BASIN BOUNDARY
- SUB-BASIN BOUNDARY
- 6130 — EXISTING CONTOUR
- 6130 — PROPOSED CONTOUR
- PROPOSED STORM SEWER
- INITIAL OVERLAND TIME (T_I)
- TRAVEL TIME (T_T)
- OVERLAND TIME (T_O)

GRAPHIC SCALE
(IN FEET)
1 inch = 100 ft.

UPSTREAM DP	BASIN	AREA (AC)	Q(5) (CFS)	Q(100) (CFS)	INLET	Q(5) (CFS)	Q(100) (CFS)	PIPE
DP1	OS01	27	29	60		29	61	36" RCP
I01	OS02	3.0	3.6	19	PR 15" SUMP	3.6	19	18" RCP
I02	OS03	6.6	7.4	19	PR 15" SUMP	7.4	19	18" RCP
J01						38	93	42" RCP
I03	A01	5.3	6.9	17	PR 15" FLOW-BY	4.6	9	18" RCP
J02						42	100	42" RCP
I04	A02	4.3	8.6	22	PR 20" FLOW-BY	6.2	13	18" RCP
J03						47	112	48" RCP
I05	A03	5.5	9.8	24	PR 20" FLOW-BY	7.7	17	18" RCP
J04						53	126	54" RCP
I06	A04	4.7	8.0	21	PR 20" FLOW-BY	6.5	14	18" RCP
J05						59	138	54" RCP
J06						59	137	54" RCP
I07	A05	2.5	4.4	9	PR 15" FLOW-BY	3.7	7	18" RCP
J07						61	141	54" RCP
I08	A06	4.5	7.8	17	PR 20" FLOW-BY	5.7	11	18" RCP
J08						5.7	11	18" RCP
I09	A07	3.6	7.7	18	PR 15" FLOW-BY	5.4	11	24" RCP
J09						11	22	24" RCP
I10						11	21	24" RCP
I10	A08	3.3	6.2	18	PR 10" SUMP	6.2	14	18" RCP
J11						66	150	54" RCP
I11	A09	5.3	7.9	18	PR 20" SUMP	7.4	168	54" RCP
A10		2.0	2.5	5.8	SWALE	2.5	5.8	
A11		1.8	2.1	5.2	SWALE	3.9	9.6	
I12	A12	9.9	15	34	PR 20" SUMP	15	34	24" RCP
DP02	OS04	102	46	158		46	159	54" RCP

BENCH MARK:
INTERSECTION OF WOODMEN RD AND MERIDIAN ROAD AT SW CORNER (BRASS CAP W/ NO. GF-9)
ELEVATION = 6874.00

NOTE:
COUNTY PLAN REVIEW IS PROVIDED ONLY FOR GENERAL CONFORMANCE WITH COUNTY DESIGN CRITERIA. THE COUNTY IS NOT RESPONSIBLE FOR THE ACCURACY AND ADEQUACY OF THE DESIGN, DIMENSIONS, AND/OR ELEVATIONS WHICH SHALL BE CONFIRMED AT THE JOB SITE. THE COUNTY THROUGH THE APPROVAL OF THIS DOCUMENT ASSUMES NO RESPONSIBILITY FOR THE COMPLETENESS AND/OR ACCURACY OF THIS DOCUMENT.

SEE SHEET 1

<p>MERIDIAN RANCH</p>	<p>RATIONAL DRAINAGE MAP FINAL DRAINAGE REPORT THE SANCTUARY FILING 1 AT MERIDIAN RANCH</p>												
<p>TECH CONTRACTORS 11886 STAPLETON DRIVE FALCON, CO 80831 TELEPHONE: 719.495.7444 FAX: 719.495.3349</p>	<table border="1" style="width: 100%; border-collapse: collapse;"> <tr> <th>No.</th> <th>Revisions</th> <th>Date</th> <th>Inst.</th> <th>Appr.</th> <th>Date</th> </tr> <tr> <td> </td> <td> </td> <td> </td> <td> </td> <td> </td> <td> </td> </tr> </table>	No.	Revisions	Date	Inst.	Appr.	Date						
No.	Revisions	Date	Inst.	Appr.	Date								
<p>Scale: 1" = 100'</p>	<p>Drawn by: TK Checked by: - Date: MAY 2022</p>												
<p>2 of 2</p>	<p>2 of 2</p>												

FIGURE 7

S:\OneDrive\Civil\Rolling Hills Filing 4\DWG\Plan Sheets\DRAINAGE MAPS\DR - FDR\SANCTUARY FILING 1\DWG\PLAN SHEETS\DRAINAGE MAP.dwg, 4/18/2022 2:01:08 PM