



ENTECH
ENGINEERING, INC.

505 ELKTON DRIVE
COLORADO SPRINGS, CO 80907
PHONE (719) 531-5599
FAX (719) 531-5238

**SOIL, GEOLOGY, GEOLOGIC HAZARD,
AND WASTEWATER STUDY,
ROLLIN RIDGE ESTATES
HODGEN ROAD AND HIGHWAY 83 – SOUTHWEST CORNER
EL PASO COUNTY, COLORADO**

Prepared for

Carl Turse
17572 Colonial Park Drive
Monument, Colorado 80132

November 24, 2017

Respectfully Submitted,

ENTECH ENGINEERING, INC.

Logan L. Langford
Geologist

LLL/nc

Encl.

Entech Job No. 170837
A\projects\2017\170837 countysoil\geo\ww

Reviewed by:

Joseph C. Gooden, Jr., P.E.
President

COLORADO LICENSED
JOSEPH COLLIN GOODEN
23725
11-24-17
PROFESSIONAL ENGINEER

TABLE OF CONTENTS

1.0 SUMMARY 1
2.0 GENERAL SITE CONDITIONS AND PROJECT DESCRIPTION 2
3.0 SCOPE OF THE REPORT 2
4.0 FIELD INVESTIGATION 3
5.0 SOIL, GEOLOGY AND ENGINEERING GEOLOGY 4
 5.1 General Geology 4
 5.2 Soil Conservation Survey 4
 5.3 Site Stratigraphy 5
 5.4 Soil Conditions 6
 5.5 Groundwater 7
6.0 ENGINEERING GEOLOGY – IDENTIFICATION AND MITIGATION OF GEOLOGIC HAZARDS 7
 6.1 Relevance of Geologic Conditions to Land Use Planning 9
7.0 ON-SITE DISPOSAL OF WASTEWATER 10
8.0 ECONOMIC MINERAL RESOURCES 12
9.0 EROSION CONTROL 13
10.0 CLOSURE 14
BIBLIOGRAPHY 15

TABLES

- Table 1: Summary of Laboratory Test Results
- Table 2: Summary of Percolation Test Results and Tactile Test Pits

FIGURES

- Figure 1: Vicinity Map
- Figure 2: USGS Map
- Figure 3: Development Plan/Test Boring Location Map
- Figure 4: Soil Survey Map
- Figure 5: Monument Quadrangle Geology Map
- Figure 6: Geology Map/Engineering Geology
- Figure 7: Floodplain Map
- Figure 8: Typical Perimeter Drain Details
- Figure 9: Septic Suitability Map - Residential Lots
- Figure 10: Septic Suitability Map - Commercial Lots

- APPENDIX A: Site Photographs
- APPENDIX B: Profile Hole Logs and Test Pit Logs
- APPENDIX C: Laboratory Test Results
- APPENDIX D: Soil Survey Descriptions
- APPENDIX E: Percolation Test Results
- APPENDIX F: El Paso County Health Department Septic Records

1.0 SUMMARY

Project Location

The project lies in a portion of the NE¼ of the NW¼ and the NW¼ of the NE¼ of Section 27, Township 11 South, Range 66 West of the 6th Principal Meridian in El Paso County, Colorado. The site is located approximately 4½ miles southeast of Monument, Colorado.

Project Description

Total acreage involved in the project is approximately 57 acres. The proposed site development consists of sixteen single-family rural residential lots and three commercial lots. The development will utilize individual wells and on-site wastewater treatment systems.

Scope of Report

This report presents the results of our geologic evaluation, treatment of engineering geologic hazard study and wastewater study for individual on-site wastewater treatment systems.

Land Use and Engineering Geology

This site was found to be suitable for the proposed development. Areas were encountered where the geologic conditions will impose some constraints on development and land use. These include areas of artificial fill, expansive soils, and seasonal shallow groundwater areas. Based on the proposed development plan, it appears that these areas will have some impact on the development. These conditions will be discussed in greater detail in the report.

In general, it is our opinion that the development can be achieved if the observed geologic conditions on site are either avoided or properly mitigated. All recommendations are subject to the limitations discussed in the report.

2.0 GENERAL SITE CONDITIONS AND PROJECT DESCRIPTION

The site is located in a portion of the NE $\frac{1}{4}$ of the NW $\frac{1}{4}$ and the NW $\frac{1}{4}$ of the NE $\frac{1}{4}$ of Section 27, Township 11 South, Range 66 West of the 6th Principal Meridian in El Paso County, Colorado. The site is located approximately 4½ miles northeast of Monument, Colorado, southwest of Hodgen Road and Highway 83. The location of the site is as shown on the Vicinity Map, Figure 1.

The topography of the site consists of rolling hills that vary from gradually to moderately sloping generally to the northwest and northeast, with steep slopes along the man-made dam in the northeastern portion of the site. The drainages on site flow in northerly direction through the eastern portion of the site. Water was not observed in the pond or drainages at the time of this investigation. The site boundaries are indicated on the USGS Map, Figure 2. Previous land uses have included grazing and pasture land. The site contains primarily field grasses and weeds with areas of ponderosa pines in the southwestern and western portion of the site. An existing house is located on Lot 8 which will remain. Several pole barns are located around the area of the house and will be removed. An existing septic system and water well are located at the house. El Paso County Health Department records for the septic are included in Appendix F. Site photographs, taken June 27 and July 10, 2017, are included in Appendix A.

Total acreage involved in the proposed development is approximately 57 acres. Sixteen single-family rural residential lots are proposed and three commercial lots. The proposed lots are approximately 2.5 to 2.8 acres each. The area will be serviced by individual wells and on-site wastewater treatment systems. The proposed Development Plan/Test Boring Location Map is presented in Figure 3.

3.0 SCOPE OF THE REPORT

The scope of the report will include the following:

- A general geologic analysis utilizing published geologic data. Detailed site-specific mapping will be conducted to obtain general information in respect to major geographic and geologic features, geologic descriptions and their effects on the development of the property.

- The site will be evaluated for individual on-site wastewater treatment systems in accordance with El Paso Land Development Code.

4.0 FIELD INVESTIGATION

Our field investigation consisted of the preparation of a geologic map of any bedrock features and significant surficial deposits. The Natural Resource Conservation Service (NRCS), previously the Soil Conservation Service (SCS) survey was also reviewed to evaluate the site. The position of mappable units within the subject property are shown on the Geologic Map. Our mapping procedures involved both field reconnaissance and measurements and air photo reconnaissance and interpretation. The same mapping procedures have also been utilized to produce the Geology/Engineering Geology Map which identified pertinent geologic conditions affecting development. The field mapping was performed by personnel of Entech Engineering, Inc. on July 10, 2017.

Two (2) percolation tests, and fourteen (14) test pits were performed on the site to determine general suitability of the site for the use of on-site wastewater treatment systems. Ten test pits were excavated in the three commercial lots for OWTS evaluations. The locations of the percolation tests, test borings, and test pits are indicated on the Development Plan/Test Boring Location Map, Figure 3. The Profile Hole and Test Pit Logs are presented in Appendix B. Results of this testing will be discussed later in this report.

Laboratory testing was also performed on some of the soils to classify and determine the soils engineering characteristics. Laboratory tests included grain-size analysis, ASTM D-422, and Atterberg Limits, ASTM D-4318. Results of the laboratory testing are included in Appendix C. A Summary of Laboratory Test Results is presented in Table 1.

5.0 SOIL, GEOLOGY AND ENGINEERING GEOLOGY

5.1 General Geology

Physiographically, the site lies in the western portion of the Great Plains Physiographic Province along the Palmer Divide. Approximately 8 miles to the west is a major structural feature known as the Rampart Range Fault. This fault marks the boundary between the Great Plains Physiographic Province and the Southern Rocky Mountain Province. The site exists within the southeastern edge of a large structural feature known as the Denver Basin. Bedrock in the area tends to be very gently dipping in a northeasterly direction (Reference 1). The rocks in the area of the site are sedimentary in nature and typically Tertiary to Upper Cretaceous in age. The bedrock underlying the site consists of the Dawson Arkose Formation. Overlying this formation are unconsolidated deposits of residual soils, man-made, and alluvial soils of the Quaternary Age. The residual soils are produced by the in-situ action of weathering of the bedrock on site. The alluvial soils were deposited by water in the major drainages on site and as stream terraces on some of the ridge lines. Man-made soils exist as earthen dams and erosion berms. The site's stratigraphy will be discussed in more detail in Section 5.3.

5.2 Soil Conservation Survey

The Natural Resource Conservation Service (Reference 2), previously the Soil Conservation Service (Reference 3) has mapped four soil types on the site (Figure 4). In general, they vary from gravelly loamy sand to sandy loam. The soils are described as follows:

<u>Type</u>	<u>Description</u>
21	Cruckton Sandy Loam, 1-9% slopes
28	Ellicott Loamy Coarse Sand, 0-5% slopes
41	Kettle Gravelly Loamy Sands, 8-40% slopes
68	Peyton-Pring Complex, 3-8% slopes

Complete descriptions of each soil type are presented in Appendix D. The soils have generally been described to typically have moderate to moderately rapid permeabilities. Roads may need to be designed to minimize frost-heave potential. Possible hazards with soil erosion are present on the site. The erosion potential can be controlled with vegetation. The majority of the soils have been described to have slight to moderate erosion hazards.

5.3 Site Stratigraphy

The Monument Quadrangle Geology Map showing the site is presented in Figure 5 (Reference 4). The Geology Map prepared for the site is presented in Figure 6. Four mappable units were identified on this site which are described as follows:

- Qal Recent Alluvium of Holocene Age:** These are recent deposits that have been deposited along the drainage that exist on-site. These materials typically consist of silty to clayey sands and sandy clays. Some of these alluviums contain highly organic soils.
- Qaf Recent Artificial Fill of Holocene Age:** These are man-made fill deposits associated with erosion berms and earthen dams on-site.
- QTa Alluvium of Palmer Divide of Pleistocene Age:** These materials consist of water-deposited stream terrace deposits. They typically consist of silty to clayey sands with gravelly lenses and may contain areas of pebble and cobble lenses.
- Tkd Dawson Formation of Tertiary to Cretaceous Age:** The Dawson formation typically consists of arkosic sandstone with interbedded fine-grained sandstone, siltstone and claystone. Overlying this formation is a variable layer of residual soil. The residual soils were derived from the in-situ weathering of the bedrock materials on-site. These soils consisted of silty to clayey sands, sandy clays and sandy silts.

The soils listed above were mapped from site-specific mapping, the *Geologic Map of the Monument Quadrangle* distributed by the Colorado Geological Survey in 2003 (Reference 4), the *Geologic Map of the Colorado Springs-Castle Rock Area*, distributed by the US Geological Survey in 1979 (Reference 5), and the *Geologic Map of the Denver 1^o x 2^o Quadrangle*, distributed by the US Geological Survey in 1981 (Reference 6). The Test Pits and Profile Holes were also used in evaluating the site and are included in Appendix B. The Geology Map prepared for the site is presented in Figure 6.

5.4 Soil Conditions

The soils encountered in the Profile Holes can be grouped into three general soil and rock types. The profile hole soils were classified using the Unified Soil Classification System (USCS). The soils encountered in the Test Pits can be grouped into three general soil types. The test pit soils were classified using the USDA Textural Soil Classification.

Soil Type 1 is a very sandy to sandy clay and silty clay loam (CL, ML). This material was encountered in both of the profile holes and in six of the test pits. The clay and silt soils were encountered at the existing surface and extended to depths ranging from 3 to 10 feet bgs. These soils were encountered at soft to firm states and at dry to moist conditions. Samples tested had 55 to 73 percent passing the No. 200 Sieve. FHA Swell Testing on a sample of sandy clay resulted in an expansion pressure of 430 psf, which is in the low expansion range.

Soil Type 2 is a clayey sand, sandy loam, and slightly silty to silty sand (SC, SM-SW). This material was encountered in Profile Hole No. 1 and in eight of the test pits. The sands were encountered at depths ranging from the existing surface grade to 3 feet and extended to depths ranging from 5 to 12 feet. The sands were encountered at medium dense to states and dry to moist conditions. Samples tested had 6 to 40 percent passing the No. 200 sieve. FHA Swell Testing on a sample of clayey sand resulted in an expansion pressure of 556 psf, which is in the low expansion range.

Soil Type 3 is a slightly silty to silty sandstone and clayey sandstone (SM-SW, SM, SC). This material was encountered in Profile Hole No. 2 and in eleven of the test pits. The sandstone was encountered at depths ranging from the 1 to 12 feet and extended to the termination of the profile hole (20 feet) and test pits (8 to 9 feet). The sandstone was encountered at dense to very dense states and moist conditions. Samples tested had 9 to 25 percent passing the No. 200 sieve. The sandstones are typically non-expansive, however; expansive clayey sandstone and claystone are common in the area.

The Test Boring Logs and the Profile Hole Logs are presented in Appendix B. Laboratory Test Results are presented in Appendix C. A Summary of Laboratory Test Results is presented in Table 1.

5.5 Groundwater

Groundwater was not encountered in the profile holes which were drilled to 10 to 20 feet. Signs of seasonally occurring groundwater was observed in ten of the test pits at depths ranging from 5 to 8 feet. Areas of seasonal shallow groundwater and ponded water have been mapped in low-lying areas and in the drainage on-site. These areas are discussed in the following section. Fluctuation in groundwater conditions may occur due to variations in rainfall and other factors not readily apparent at this time.

It should be noted that in the sandy materials on site, some groundwater conditions might be encountered due to the variability in the soil profile. Isolated sand and gravel layers within the soils, sometimes only a few feet in thickness and width, can carry water in the subsurface. Groundwater may also flow on top of the underlying bedrock. Builders and planners should be cognizant of the potential for the occurrence of such subsurface water features during construction on-site and deal with each individual problem as necessary at the time of construction.

6.0 ENGINEERING GEOLOGY – IDENTIFICATION AND MITIGATION OF GEOLOGIC HAZARDS

As mentioned previously, detailed mapping has been performed on this site to produce an Geology/Engineering Geology Map (Figure 6). This map shows the location of various geologic conditions of which the developers should be cognizant during the planning, design and construction stages of the project. These hazards and the recommended mitigation techniques are as follows:

Artificial Fill

These are man-made fill deposits associated with erosion berms and the earthen dam on-site.

Mitigation: The earthen dam will be avoided by the development, and the small erosion berms can easily be removed or penetrated by foundations. Should any uncontrolled fill be encountered beneath foundations, removal and recompaction at 95% of its maximum Modified Proctor Dry Density, ASTM D-1557 will be required.

Expansive Soils

Expansive soils were encountered in the test borings drilled and test pits excavated on-site. Expansive claystone is commonly encountered within the Dawson Formation. These occurrences are typically sporadic; therefore, none have been indicated on the maps. These expansive, if encountered beneath foundations, can cause differential movement in the structure foundation. These occurrences should be identified and mitigated on an individual basis.

Mitigation: Should expansive soils be encountered beneath the foundation, mitigation will be necessary. Mitigation of expansive soils will require special foundation design. Overexcavation and replacement with non-expansive soils at a minimum of 95% of its maximum Modified Proctor Dry Density, ASTM D-1557 is a suitable mitigation, which is common in the area. Another alternative in areas of highly expansive soils is the use of drilled pier foundation systems. Typical minimum pier depths are on the order of 20 feet or more and require penetration into the bedrock material a minimum of 4 to 6 feet, depending upon building loads. Floor slabs on expansive soils should be expected to experience movement. Overexcavation and replacement has been successful in minimizing slab movements. The use of structural floors should be considered for basement construction on highly expansive clays. Final recommendations should be determined after additional investigation of each building site.

Floodplain and Seasonal Shallow Groundwater Area

The site is not mapped within any floodplains according to the FEMA Map No. 08041CO285F, dated March 17, 1997 (Figure 7, Reference 7). Areas of seasonal shallow groundwater were observed across the site. In these areas, we would anticipate the potential for periodically high subsurface moisture conditions and frost heave potential. These areas lie within low-lying areas along the drainage in the eastern portion of the site and in the low-lying area in the northwest corner of the site, and the pond located in the northeastern portion of the site. Water was not observed in any of the drainages or the pond at the time of our site investigation. These areas can likely be avoided or properly mitigated by development. The potential exists for high groundwater levels during high moisture periods and should structures encroach on these areas the following precautions should be followed.

Mitigation: Foundations must have a minimum 30-inch depth for frost protection. In areas where high subsurface moisture conditions are anticipated periodically, subsurface perimeter drains are recommended to help prevent the intrusion of water into areas below grade. Typical drain details are presented in Figure 8. Any grading in these areas should be done to direct surface flow around construction to avoid areas of ponded water. All organic material would be completely removed prior to any fill placement. Specific drainage studies are beyond the scope of this report.

6.1 Relevance of Geologic Conditions to Land Use Planning

As mentioned earlier in this report, we understand that the development will be rural residential and commercial. It is our opinion that the existing geologic and engineering geologic conditions will impose some minor constraints on the proposed development and construction. The most significant problems affecting development will be those associated with the drainages on site that can be avoided or properly mitigated during site grading. Other hazards on site may be satisfactorily mitigated through proper engineering design and construction practices.

The upper materials are typically at medium dense states and firm consistencies. The granular soils encountered in the upper soil profiles of the profile holes and test pits should provide good support for foundations. Expansive soils although sporadic were encountered. Expansive clayey sandstone and claystone is common in the Dawson Formation, and may require mitigation. Foundations anticipated for the site are standard spread footings possibly in conjunction with overexcavation in areas of expansive soils or loose soils. Areas containing arkosic sandstone will have high allowable bearing conditions. Difficult excavation should be anticipated in areas of shallow bedrock. Expansive layers may also be encountered in the soil and bedrock on this site. Areas of expansive soils encountered on site are sporadic; therefore, none have been indicated on the maps. Expansive soils, if encountered, will require special foundation design and/or overexcavation. These soils will not prohibit development.

Areas of seasonal shallow groundwater and potentially seasonal shallow groundwater were encountered on site. A pond and earthen dam are located in the northeastern portion of the site. Water was not observed in the pond or drainages on-site. Due to the size of the lots and the proposed development, these areas can be avoided by construction on the residential lots. Structures should not block drainages. Septic fields should not be located in these areas due to the potential for periodic high groundwater conditions.

Development of the commercial lots will likely require significant site grading. Based on the Development Plan (Figure, 3) the existing dam and pond will be removed, and a new detention pond constructed at the southeast corner of the proposed Cherry Crossing Court and Hodgen Road. All organic material will need to be completely removed prior to any fill placement in the area of the existing pond or drainages to receive fill during the site development.

In summary, development of the site can be achieved if the items mentioned above are mitigated. These items can be mitigated through proper design and construction or through avoidance. Investigation on each lot is recommended prior to construction.

7.0 ON-SITE WASTEWATER TREATMENT

The site was evaluated for individual and commercial on-site wastewater treatment systems in accordance with El Paso Land Development Code. Two (2) percolation tests and fourteen (14) test pits were performed on the property. Percolation tests and test pits were located in potential locations of future systems. Four (4) of the test pits were excavated on the residential lots, and ten (10) of the test pits were excavated on the commercial lots. The approximate locations of the percolation tests are indicated on Figure 3, on the Geology/Engineering Geology Map, Figure 6, and on the Septic Suitability Maps, Figures 9 and 10. A table showing the results of the percolation tests is presented in Table 2. The specific percolation test results are presented in Appendix E of this report.

The Natural Resource Conservation Service (Reference 2), previously the Soil Conservation Service (Reference 3) has been mapped with four soil descriptions. The Soil Survey Map (Reference 2) is presented in Figure 4, and the Soil Survey Descriptions are presented in Appendix D. The soils are described as having moderate to moderately rapid percolation rates.

The percolation rates were 67 and 76 minutes per inch. Neither of the percolation rates are suitable for conventional on-site wastewater treatment systems. Both of the percolation rates are slower than 60 minutes per inch which will require designed systems. Shallow bedrock was also encountered in ten of the test pits, which will required designed systems. Additional investigation may identify areas where suitable for conventional systems could be used.

Standard penetration testing, ASTM D-1586, was performed in each profile hole to evaluate the density of the soil and the presence of bedrock. Bedrock was encountered in Profile Hole No. 2 at 12 feet. Absorption fields must be maintained a minimum of 4 feet above groundwater bedrock, or confining layer. Groundwater was not encountered in the profile holes which were drilled to depths of 10 to 20 feet. Shallow bedrock was encountered in ten (10) of the test pits at depths ranging from 1.5 to 6 feet. Should groundwater or bedrock be encountered within 6 feet of the surface, designed systems will be required.

Soils encountered in the tactile test pits consisted of loamy sand, silty clay loam and sandy clay, with underlying weathered silty to slightly silty sandstone and clayey sandstone. The limiting layers encountered in the test pits are the sandy loam, silty clay loam, sandy clay, and weathered sandstone, which corresponds to an LTAR values of 0.35 to 0.15 gallons per day per square foot. The bedrock was encountered at approximately 5 feet in Test Pit No. 3. The conditions encountered in the Test Pit No. 3 will require a designed system.

Commercial Lots

Test pits (TP-5 to TP-14) were excavated in potential areas of absorptions fields and alternate locations on the commercial lots. Two of the proposed fields are located in the existing pond and drainage area in the western portion of Lot 19. Additional testing for these field will be required after site grading is completed. The other test locations should be evaluated after grading is completed to determine if test results from our investigation remain valid.

In summary, it is our opinion the site is suitable for individual and commercial on-site wastewater treatment systems (OWTS) and that contamination of surface and subsurface water resources should not occur provided the OWTS sites are evaluated and installed according to El Paso County and State Guidelines and properly maintained. Based on the testing performed as part of this investigation designed systems will be required for the majority of the lots. Septic Suitability Maps are presented in Figures 9 and 10. Individual soil testing is required on each lot prior to construction. Absorption fields must be located a minimum of 100 feet from any well, including those on adjacent properties. Absorption fields must also be located a minimum of 50 feet from any drainages, floodplains or ponded areas and 25 feet from dry gulches.

8.0 ECONOMIC MINERAL RESOURCES

Some of the sandy materials on-site could be considered a low-grade sand resource. According to the *El Paso County Aggregate Resource Evaluation Map* (Reference 8), the area is not mapped with any aggregate deposits. According to the *Atlas of Sand, Gravel and Quarry Aggregate Resources, Colorado Front Range Counties* distributed by the Colorado Geological Survey (Reference 9), areas of the site are not mapped with any resources. According to the *Evaluation of Mineral and Mineral Fuel Potential* (Reference 10), the area of the site has been mapped as "Fair" for industrial minerals. However, considering the silty to clayey nature of much of these materials and abundance of similar materials through the region and the close proximity to developed land, they would be considered to have little significance as an economic resource.

According to the *Evaluation of Mineral and Mineral Fuel Potential of El Paso County State Mineral Lands* (Reference 10), the site is mapped within the Denver Basin Coal Region. However, the area of the site has been mapped as "Poor" for coal resources. No active or inactive mines have been mapped in the area of the site. No metallic mineral resources have been mapped on the site (Reference 10).

The site has been mapped as "Fair" for oil and gas resources (Reference 10). No oil or gas fields have been discovered in the area of the site. The sedimentary rocks in the area may lack the geologic structure for trapping oil or gas; therefore, it may not be considered a significant resource. Hydraulic fracturing is a new method that is being used to extract oil and gas from rocks. It utilizes pressurized fluid to extract oil and gas from rocks that would not normally be productive. The area of the site has not been explored to determine if the rocks underlying the site would be commercially viable utilizing hydraulic fracturing. The practice of hydraulic fracturing has come under review due to concerns about environmental impacts, health and safety.

9.0 EROSION CONTROL

The soil types observed on the site are mildly to highly susceptible to wind erosion, and moderately to highly susceptible to water erosion. A minor wind erosion and dust problem may be created for a short time during and immediately after construction. Should the problem be considered severe enough during this time, watering of the cut areas or the use of chemical palliative may be required to control dust. However, once construction has been completed and vegetation re-established, the potential for wind erosion should be considerably reduced.

With regard to water erosion, loosely compacted soils will be the most susceptible to water erosion, residually weathered soils and weathered bedrock materials become increasingly less susceptible to water erosion. For the typical soils observed on site, allowable velocities or unvegetated and unlined earth channels would be on the order of 3 to 4 feet/second, depending upon the sediment load carried by the water. Permissible velocities may be increased through the use of vegetation to something on the order of 4 to 7 feet/second, depending upon the type of vegetation established. Should the anticipated velocities exceed these values, some form of channel lining material may be required to reduce erosion potential. These might consist of some of the synthetic channel lining materials on the market or conventional riprap. In cases where ditch-lining materials are still insufficient to control erosion, small check dams or sediment traps may be required. The check dams will serve to reduce flow velocities, as well as provide small traps for containing sediment. The determination of the amount, location and placement of ditch linings, check dams and of the special erosion control features should be performed by or in conjunction with the drainage engineer who is more familiar with the flow quantities and velocities.

Cut and fill slope areas will be subjected primarily to sheetwash and rill erosion. Unchecked rill erosion can eventually lead to concentrated flows of water and gully erosion. The best means to combat this type of erosion is, where possible, the adequate re-vegetation of cut and fill slopes. Cut and fill slopes having gradients more than three (3) horizontal to one (1) vertical become increasingly more difficult to revegetate successfully. Therefore, recommendations pertaining to the vegetation of the cut and fill slopes may require input from a qualified landscape architect and/or the Soil Conservation Service.

10.0 CLOSURE

It is our opinion that the existing geologic engineering and geologic conditions will impose some minor constraints on development and construction of the site. The majority of these conditions can be avoided by construction. Others can be mitigated through proper engineering design and construction practices. The proposed development and use is consistent with anticipated geologic and engineering geologic conditions.

It should be pointed out that because of the nature of data obtained by random sampling of such variable and non-homogeneous materials as soil and rock, it is important that we be informed of any differences observed between surface and subsurface conditions encountered in construction and those assumed in the body of this report. Individual investigations for building sites and septic systems will be required prior to construction. Construction and design personnel should be made familiar with the contents of this report. Reporting such discrepancies to Entech Engineering, Inc. soon after they are discovered would be greatly appreciated and could possibly help avoid construction and development problems.

This report has been prepared for Carl Turse, for application to the proposed project in accordance with generally accepted geologic soil and engineering practices. No other warranty expressed or implied is made.

We trust that this report has provided you with all the information that you required. Should you require additional information, please do not hesitate to contact Entech Engineering, Inc.

BIBLIOGRAPHY

1. Bryant, Bruce; McGrew, Laura W, and Wabus, Reinhard A. 1981. *Geologic Structure Map of the Denver 1° x 2° Quadrangle, North-Central Colorado*. Sheet 2. U.S. Geologic Survey. Map I-1163.
2. Natural Resource Conservation Service, September 23, 2016. *Web Soil Survey*. United States Department Agriculture, <http://websoilsurvey.sc.egov.usda.gov/App/HomePage.htm>.
3. United States Department of Agriculture Soil Conservation Service. June 1981. *Soil Survey of El Paso County Area, Colorado*.
4. Thorson, Jon P. and Madole, Richard F., 2003. *Geologic Map of the Monument Quadrangle, El Paso County, Colorado*. Colorado Geological Survey. Open-File Report 02-40.
5. Trimble, Donald E. and Machette, Michael N. 1979. *Geologic Map of the Colorado Springs-Castle Rock Area, Front Range Urban Corridor, Colorado*. USGS, Map I-857-F.
6. Bryant, Bruce; McGrew, Laura W. and Wobus, Reinhard A. 1981. *Geologic Map of the Denver 1° x 2° Quadrangle, North-Central Colorado*. U.S. Geologic Survey. Map 1-1163.
7. Federal Emergency Management Agency. March 17, 1997. *Flood Insurance Rate Maps for the City of Colorado Springs, Colorado*. Map Number 08041CO315F
8. El Paso County Planning Development. December 1995. *El Paso County Aggregate Resource Evaluation Maps*.
9. Schwochow, S.D.; Shroba, R.R. and Wicklein, P.C. 1974. *Atlas of Sand, Gravel, and Quarry Aggregate Resources, Colorado Front Range Counties*. Colorado Geological Survey. Special Publication 5-B.
10. Keller, John W.; TerBest, Harry and Garrison, Rachel E. 2003. *Evaluation of Mineral and Mineral Fuel Potential of El Paso County State Mineral Lands Administered by the Colorado State Land Board*. Colorado Geological Survey. Open-File Report 03-07.

TABLES

TABLE 1

SUMMARY OF LABORATORY TEST RESULTS

CLIENT CARL TURSE
 PROJECT ROLLIN RIDGE ESTATES
 JOB NO. 170837

SOIL TYPE	TEST BORING NO.	DEPTH (FT)	WATER (%)	DRY DENSITY (PCF)	PASSING NO. 200 SIEVE (%)	LIQUID LIMIT (%)	PLASTIC INDEX (%)	SULFATE (WT %)	FHA SWELL (PSF)	SWELL/CONSOL (%)	UNIFIED CLASSIFICATION	SOIL DESCRIPTION
1	1	2-3			55.0						CL	CLAY, VERY SANDY
1	TP-1	2-3			71.7			430			CL	CLAY, SANDY
1	TP-1	5-6			56.0						ML	SILTY CLAY LOAM
1	TP-2	2-3			62.2						ML	SILTY CLAY LOAM
1	TP-3	2-3			63.2						ML	SILTY CLAY LOAM
1	TP-5	2-3			58.2						CL	CLAY, VERY SANDY
1	TP-10	6-8			54.5						CL	CLAY, VERY SANDY
1	TP-14	3-4			64.5						CL	CLAY, SANDY
2	2	5			34.6				556		SC	SAND, CLAYEY
2	TP-4	5-6			38.9						SC	SANDY LOAM
2	TP-5	6-8			6.0						SM-SW	SAND, SLIGHTLY SILTY
2	TP-6	3-8			41.7						SC	SAND, VERY CLAYEY
2	TP-11	4-6			26.4						SM	SAND, SILTY
3	2	15			11.9						SM-SW	SANDSTONE, SLIGHTLY SILTY
3	TP-3	5-6			13.9						SC	SANDSTONE, CLAYEY
3	TP-7	6-8			8.8						SM-SW	SANDSTONE, SLIGHTLY SILTY
3	TP-8	6-8			14.3						SM	SANDSTONE, SILTY
3	TP-12	5-6			12.2						SM	SANDSTONE, SILTY
3	TP-13	1.5-8			25.4						SM	SANDSTONE, SILTY

Table 2: Summary of Percolation Test and Tactile Test Pit Results

Percolation Test No.	Percolation Rate (min/in)	Depth to Bedrock (ft.)	Depth to Groundwater (ft.)
1	67*	N/A	N/A
2	76*	12	N/A

Test Pit No.	USDA Soil Type	LTAR Value	Depth to Bedrock (ft.)	Depth to Seasonally Occurring Groundwater (ft.)
1	3	0.35	N/A	N/A
2	3	0.35	N/A	N/A
3	4A*	0.15	5**	N/A
4	2A	0.50	N/A	N/A
5	3A*	0.30	6**	6
6	3A*	0.30	8**	8
7	3A*	0.30	5**	6.5
8	4*	0.20	6**	6
9	4A*	0.15	6**	6
10	4A*	0.15	6**	6
11	3A*	0.30	5**	5
12	3A*	0.30	5**	5
13	3A*	0.30	1**	N/A
14	3A*	0.30	5**	5

*- Conditions that will require an engineered OWTS

** - Sandstone highly weathered to formational (Dawson Formation)

FIGURES



SITE



ENTECH
ENGINEERING, INC.
505 ELKTON DRIVE
 COLORADO SPRINGS, CO. 80907 (719) 531-5599

VICINITY MAP
ROLLIN RIDGE ESTATES
HODGEN ROAD AND HIGHWAY 83
EL PASO COUNTY, CO.
FOR: CARL TURSE

DRAWN: LLL	DATE: 7/19/17	CHECKED:	DATE:
----------------------	-------------------------	-----------------	--------------

JOB NO.:
170837
FIG NO.:
1

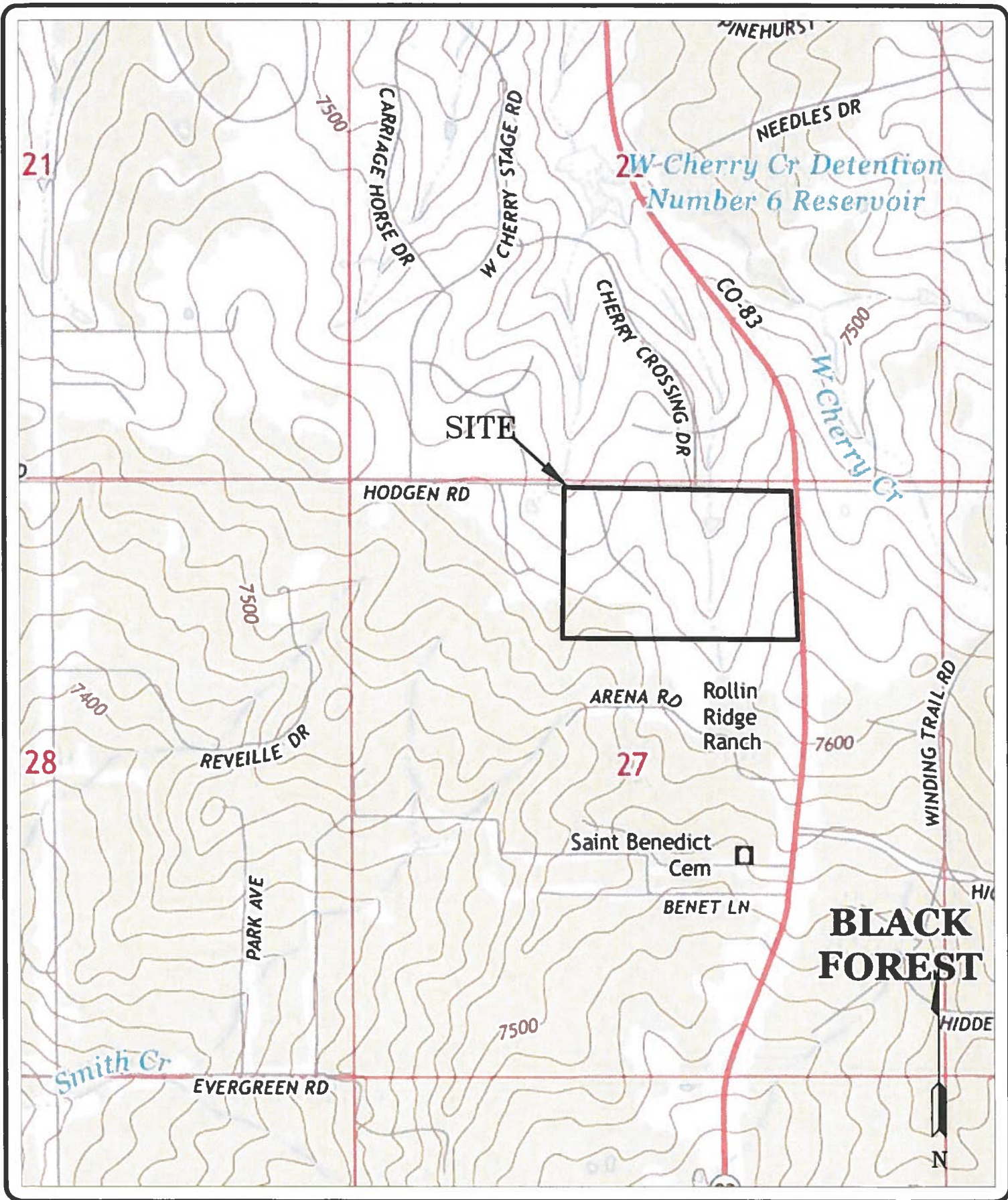



ENTECH
ENGINEERING, INC.
505 ELKTON DRIVE
COLORADO SPRINGS, CO. 80907 (719) 531-3399

USGS MAP
ROLLIN RIDGE ESTATES
HODGEN ROAD AND HIGHWAY 83
EL PASO COUNTY, CO.
FOR: CARL TURSE

DRAWN: LLL	DATE: 10/17/16	CHECKED:	DATE:
---------------	-------------------	----------	-------

JOB NO.:
170837

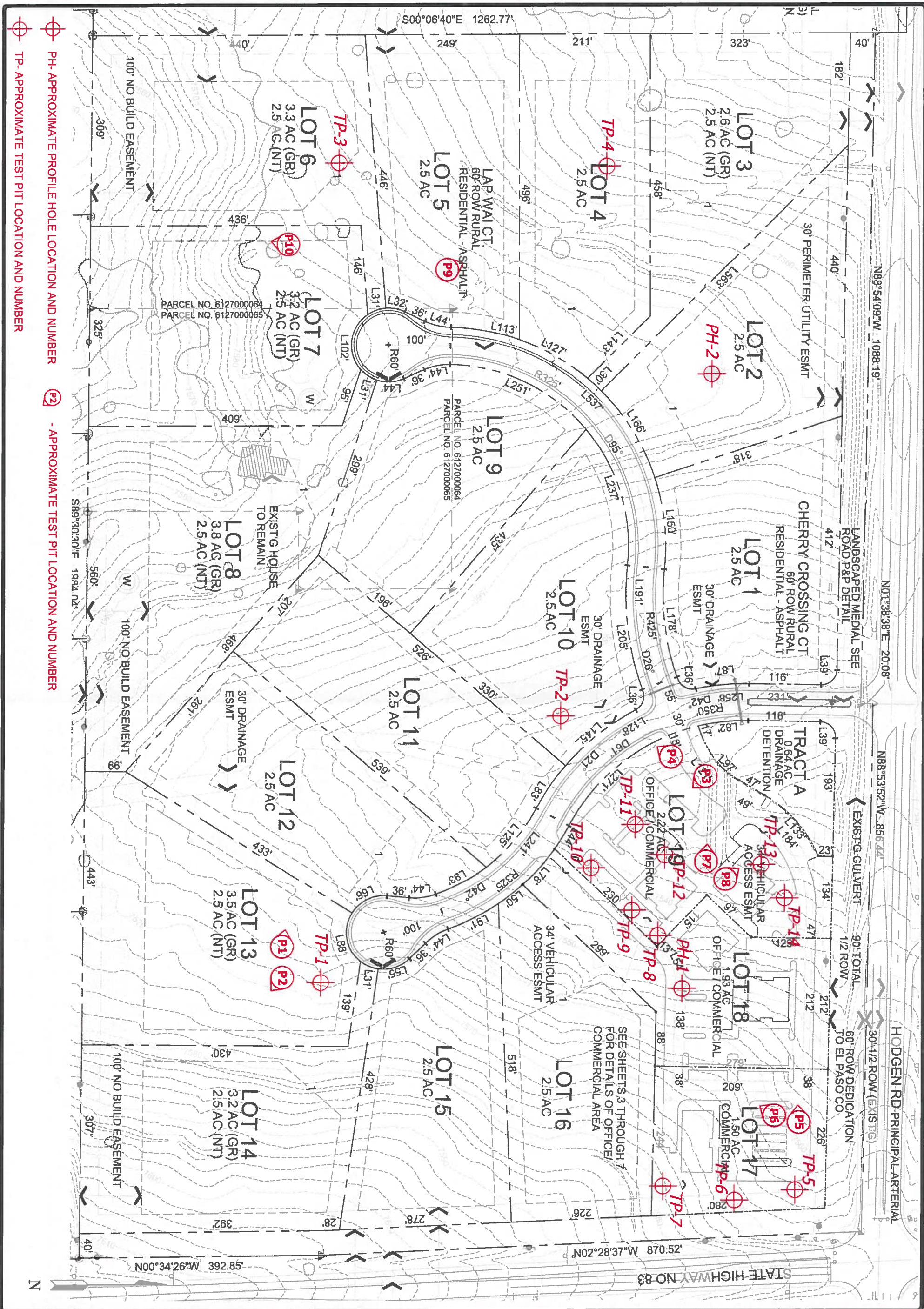
FIG NO.:
2



PH- APPROXIMATE PROFILE HOLE LOCATION AND NUMBER
 TP- APPROXIMATE TEST PIT LOCATION AND NUMBER

DEVELOPMENT PLAN/TEST BORING AND TEST PIT LOCATION MAP
 ROLLIN RIDGE ESTATES
 HODGEN ROAD AND HIGHWAY 83
 EL PASO COUNTY, CO.
 FOR: CARL TURSE

ENTECH ENGINEERING, INC.
 505 ELKTON DRIVE
 COLORADO SPRINGS, CO. 80907 (719) 531-5599

REVISION	BY

DATE	SCALE	AS SHOWN	DATE
10/27/17	AS SHOWN	1708937	FILED IN

3



ENTECH
ENGINEERING, INC.
505 ELKTON DRIVE
COLORADO SPRINGS, CO. 80907 (719) 531-5599

SCS MAP
ROLLIN RIDGE ESTATES
HODGEN ROAD AND HIGHWAY 83
EL PASO COUNTY, CO.
FOR: CARL TURSE

DRAWN:
LLL

DATE:
7/19/17

CHECKED:

DATE:

JOB NO.:
170837

FIG NO.:
4

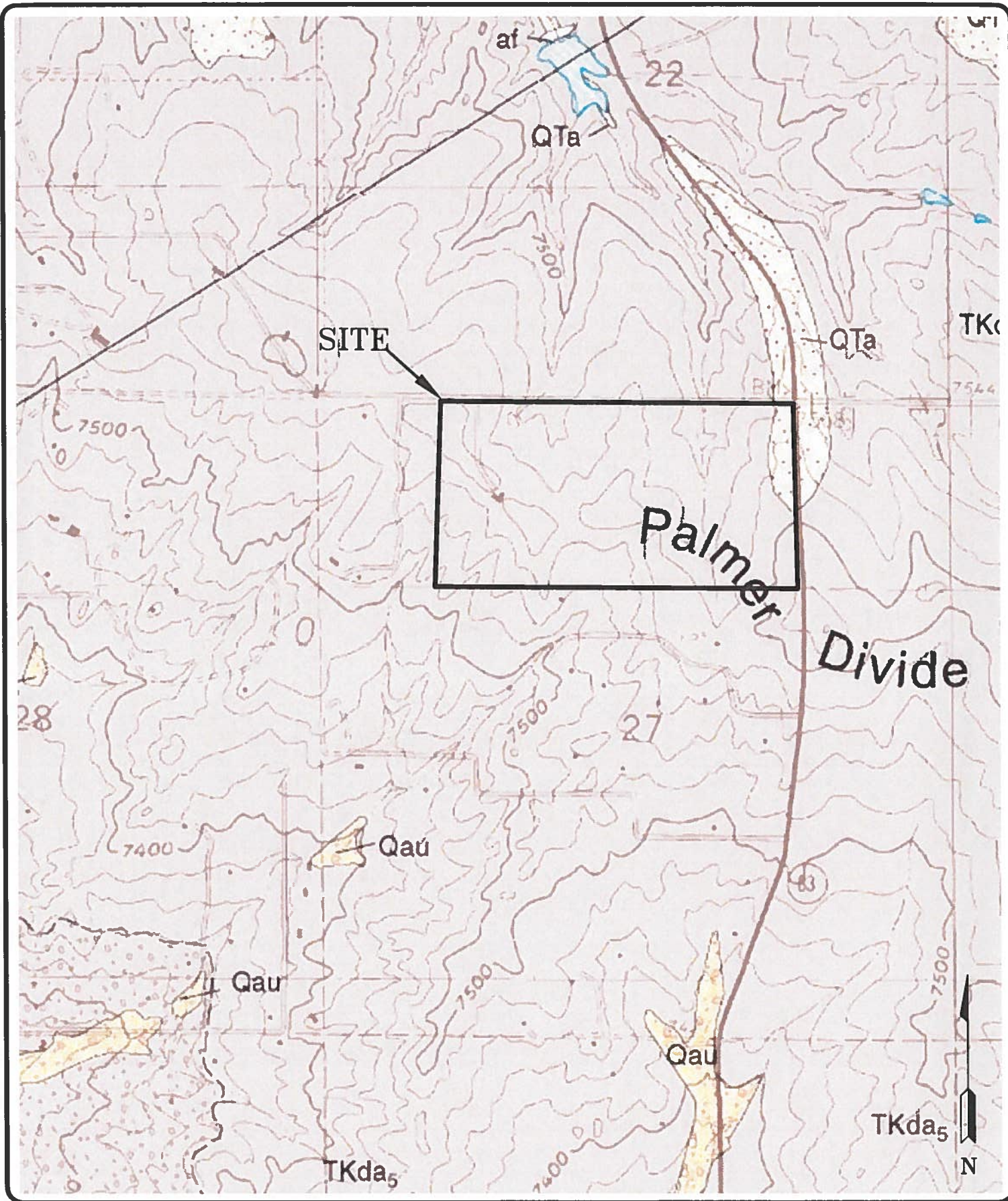

ENTECH
ENGINEERING, INC.
505 ELIXTON DRIVE
COLORADO SPRINGS, CO. 80907 (719) 531-5599

MONUMENT QUADRANGLE GEOLOGIC MAP
ROLLIN RIDGE ESTATES
HODGEN ROAD AND HIGHWAY 83
EL PASO COUNTY, CO.
FOR: CARL TURSE

DRAWN: LLL	DATE: 7/19/17	CHECKED:	DATE:
---------------	------------------	----------	-------

JOB NO.:
170837

FIG NO.:
5

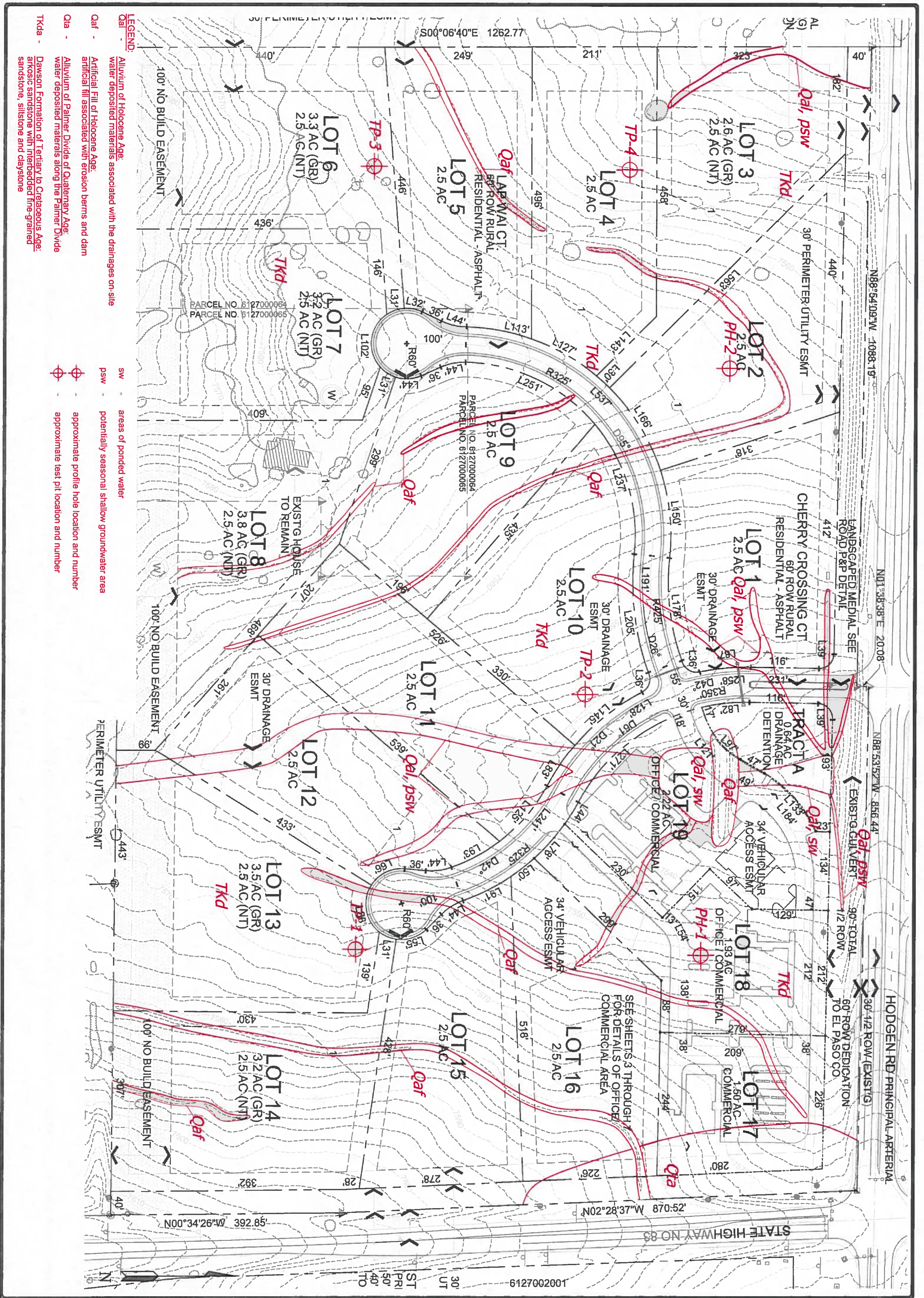

- LEGEND:**
- Qal - Alluvium of Holocene Age
 - psw - water deposited materials associated with the drainages on-site
 - TKd - Artificial fill associated with erosion berms and dam
 - Oia - Alluvium of Palmer Divide of Quaternary Age
 - TKda - water deposited materials along the Palmer Divide
 - TKda - Dawson Formation of Tertiary to Cretaceous Age: arkosic sandstone with interbedded fine-grained sandstone, siltstone and claystone

- SW - areas of ponded water
- psw - potentially seasonal shallow groundwater area
- TP-1, TP-2, TP-3, TP-4 - approximate test pit location and number
- PH-1, PH-2 - approximate profile hole location and number

GEOLOGY/ENGINEERING GEOLOGY MAP
 ROLLIN RIDGE ESTATES
 HODGEN ROAD AND HIGHWAY 83
 EL PASO COUNTY, CO.
 FOR: CARL TURSE

ENTECH ENGINEERING, INC.
 505 ELKTON DRIVE
 COLORADO SPRINGS, CO. 80907 (719) 531-5599

DATE	10/28/17
SCALE	AS SHOWN
DRAWN BY	AS SHOWN
CHECKED	170837
PROJECT NO.	6

REVISION	BY

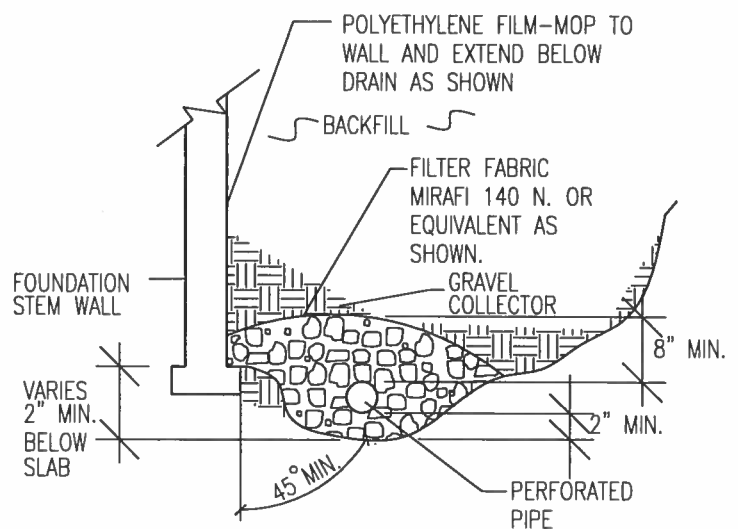
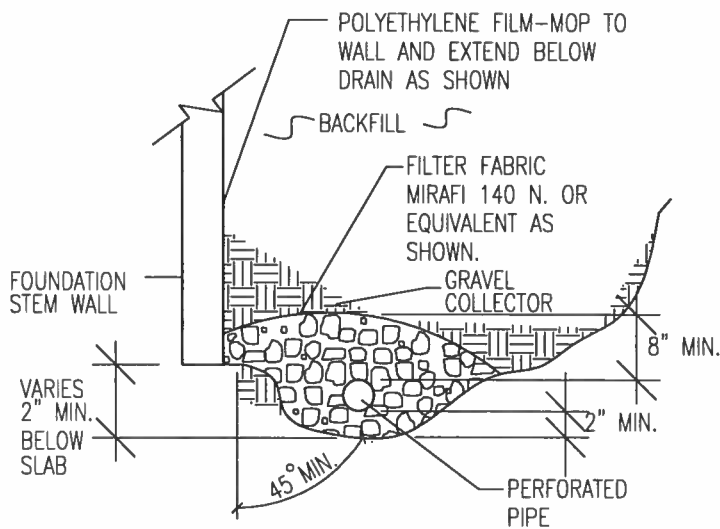

NOTES:

-GRAVEL SIZE IS RELATED TO DIAMETER OF PIPE PERFORATIONS-85% GRAVEL GREATER THAN 2x PERFORATION DIAMETER.

-PIPE DIAMETER DEPENDS UPON EXPECTED SEEPAGE. 4-INCH DIAMETER IS MOST OFTEN USED.

-ALL PIPE SHALL BE PERFORATED PLASTIC. THE DISCHARGE PORTION OF THE PIPE SHOULD BE NON-PERFORATED PIPE.

-FLEXIBLE PIPE MAY BE USED UP TO 8 FEET IN DEPTH, IF SUCH PIPE IS DESIGNED TO WITHSTAND THE PRESSURES. RIGID PLASTIC PIPE WOULD OTHERWISE BE REQUIRED.

-MINIMUM GRADE FOR DRAIN PIPE TO BE 1% OR 3 INCHES OF FALL IN 25 FEET.

-DRAIN TO BE PROVIDED WITH A FREE GRAVITY OUTFALL, IF POSSIBLE. A SUMP AND PUMP MAY BE USED IF GRAVITY OUT FALL IS NOT AVAILABLE.



ENTECH
ENGINEERING, INC.
 505 ELKTON DRIVE
 COLORADO SPRINGS, CO. 80907 (719) 531-5599

PERIMETER DRAIN DETAIL

DRAWN:

DATE DRAWN:

DESIGNED BY:

CHECKED:

DS

LLL

JOB NO.:

170837

FIG. NO.:

8

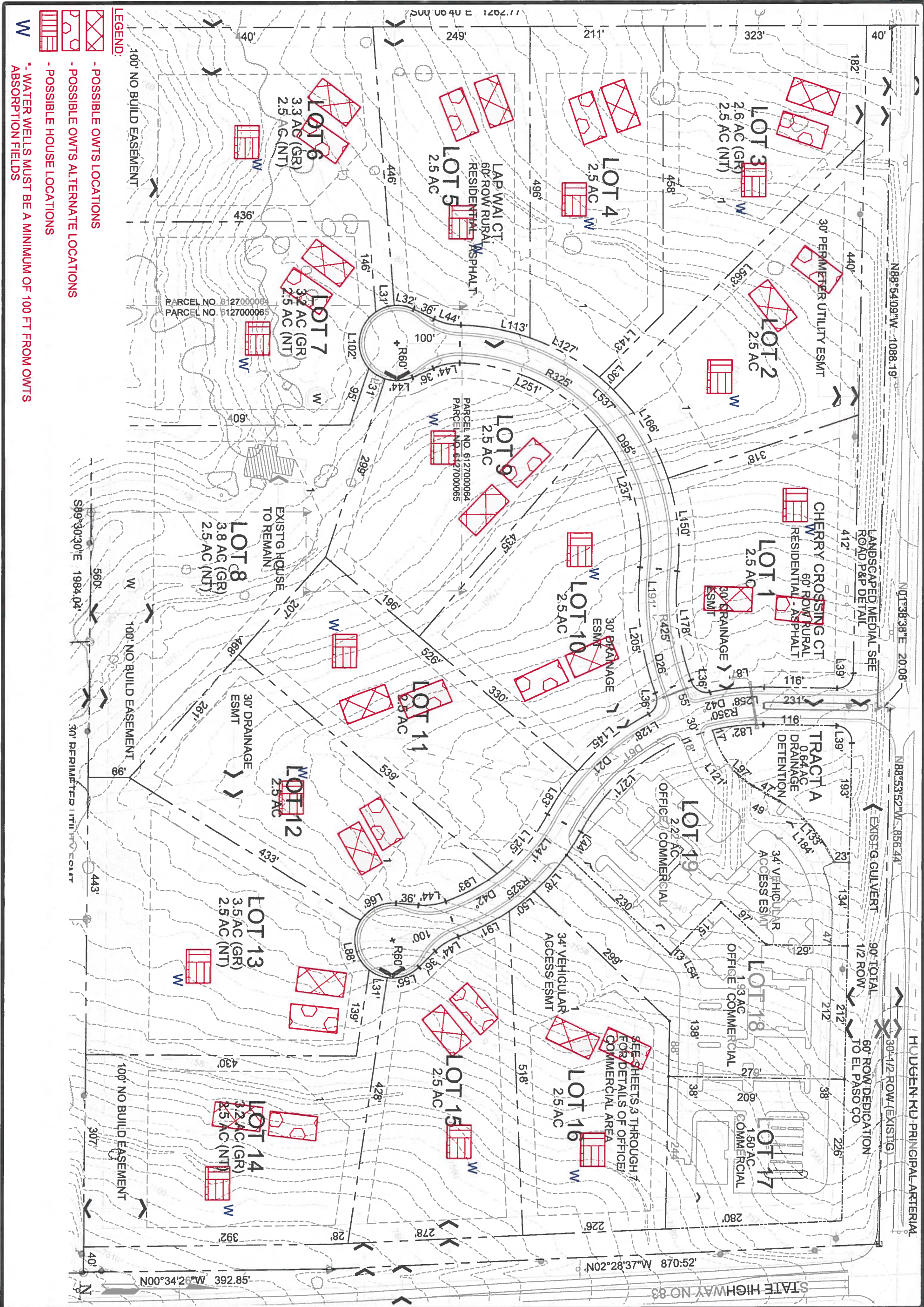

- LEGEND:**
- POSSIBLE OWTS LOCATIONS
 - POSSIBLE OWTS ALTERNATE LOCATIONS
 - POSSIBLE HOUSE LOCATIONS
 - WATER WELLS MUST BE A MINIMUM OF 100 FT FROM OWTS ABSORPTION FIELDS
 - 100' NO BUILD EASEMENT
 - 30' PERIMETER UTILITY ESMT
 - 30' DRAINAGE ESMT
 - 34' VEHICULAR ACCESS ESMT
 - EXIST'G. GULVERT
 - EXIST'G. HOUSE TO REMAIN
 - LANDSCAPED MEDIAL SEE ROAD P&P DETAIL
 - HOUGEN RD PRINCIPAL ARTERIAL
 - STATE HIGHWAY NO 83

DATE	7/19/17
SCALE	AS SHOWN
JOB NO.	170837
DESIGNER	FAJALE, MA.
9	

SEPTIC SUITABILITY MAP
 ROLLIN RIDGE ESTATES
 HODGEN ROAD AND HIGHWAY 83
 EL PASO COUNTY, CO.
 FOR: CARL TURSE

ENTECH
 ENGINEERING, INC.
 505 ELKTON DRIVE
 COLORADO SPRINGS, CO. 80907 (719) 531-5599

REVISION	BY

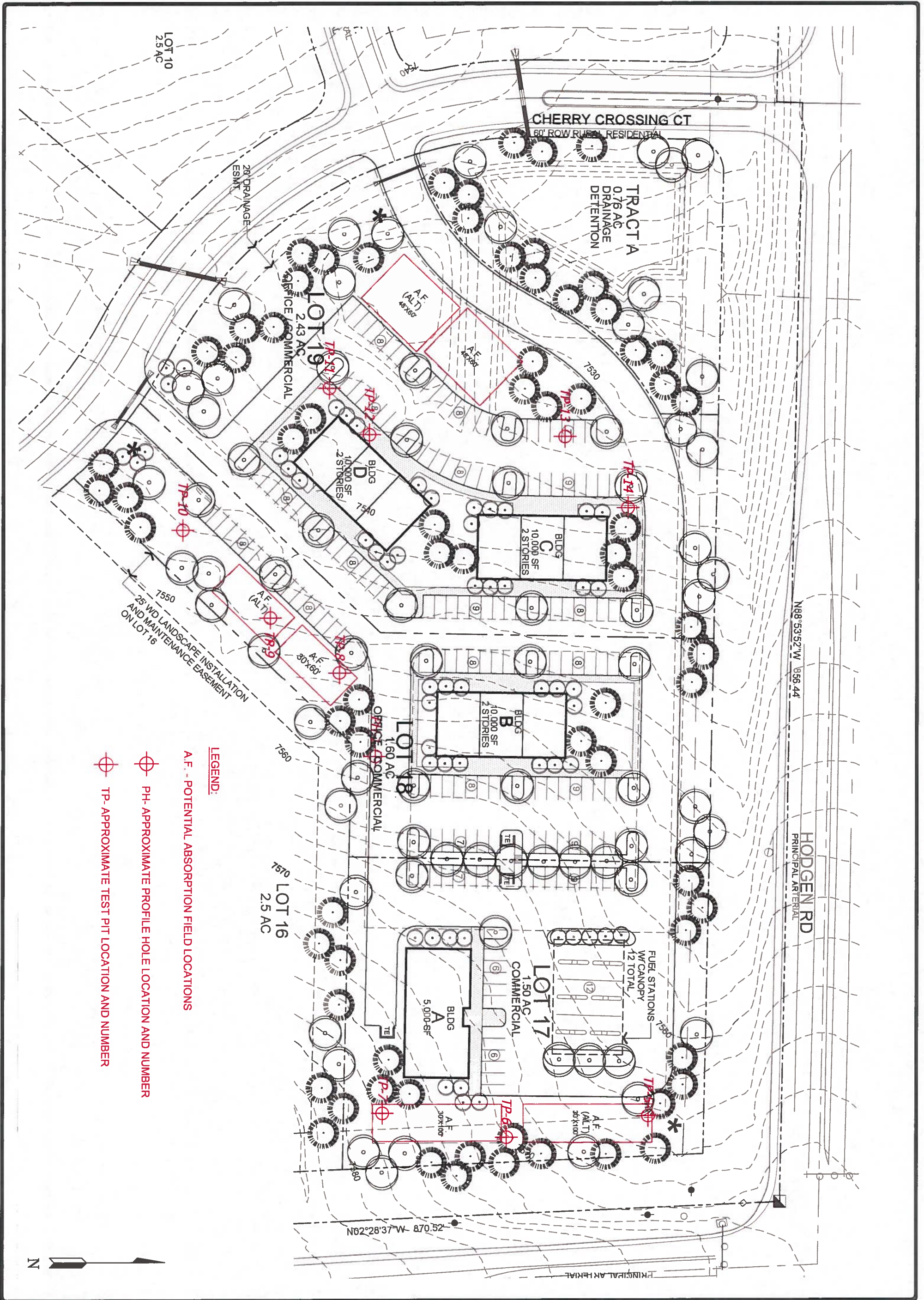

- LEGEND:**
- A.F. - POTENTIAL ABSORPTION FIELD LOCATIONS
 - PH - APPROXIMATE PROFILE HOLE LOCATION AND NUMBER
 - TP - APPROXIMATE TEST PIT LOCATION AND NUMBER

DATE	10/25/17
SCALE	AS SHOWN
DWG. NO.	1708937
FIGURE NO.	10
DRAWN	TLL
CHECKED	

SEPTIC SUITABILITY MAP COMMERCIAL LOTS
 ROLLIN RIDGE ESTATES
 HODGEN ROAD AND HIGHWAY 83
 EL PASO COUNTY, CO.
 FOR: CARL TURSE

ENTECH
 ENGINEERING, INC.
 505 ELKTON DRIVE
 COLORADO SPRINGS, CO. 80907 (719) 531-5599

REVISION	BY

APPENDIX A: Site Photographs

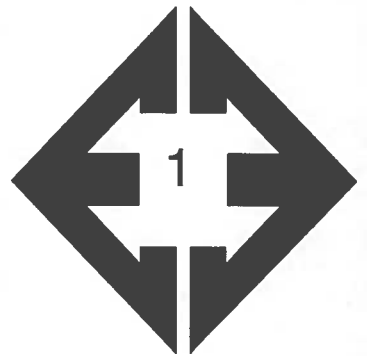
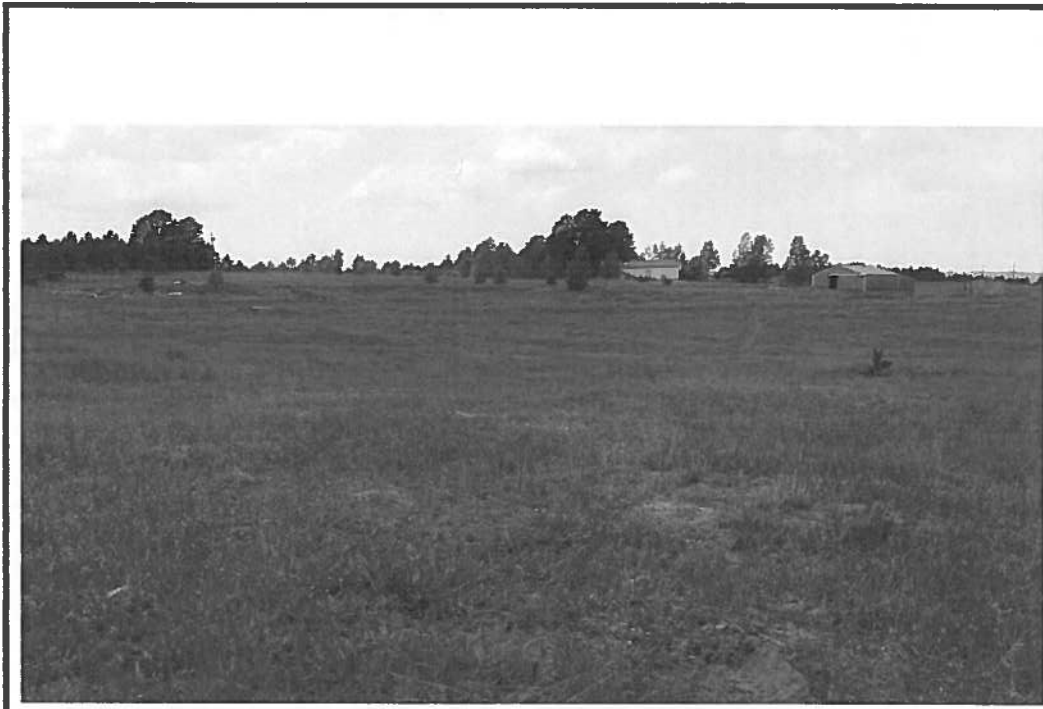

Looking west from the southeastern portion of the site.

June 27, 2017



Looking southeast from Test Pit No. 1 in the southeastern portion of the site.

June 27, 2017

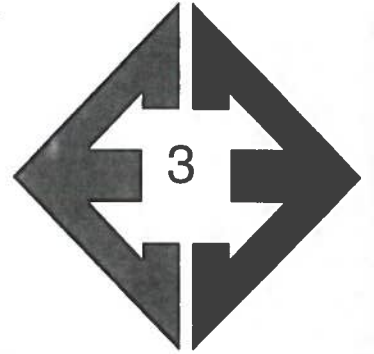

**Looking southeast
from the pond in the
northeastern portion of
the site.**

June 27, 2017

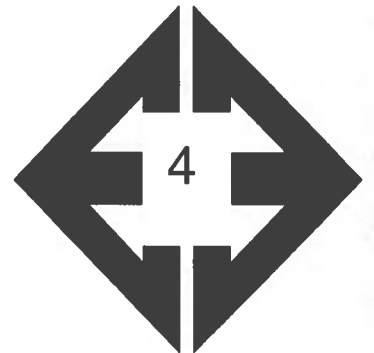

**Looking southwest
from the northern
portion of the site.**

June 27, 2017

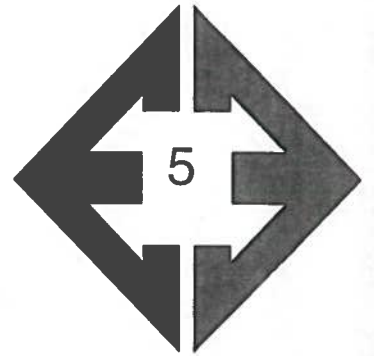

**Looking west from the
northeast corner of the
site.**

July 10, 2017

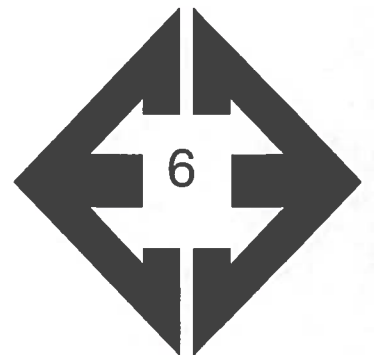

**Looking southwest
from the northeast
corner of the site.**

July 10, 2017



**Looking west along
the dam located in the
northeastern portion of
the site.**

July 10, 2017

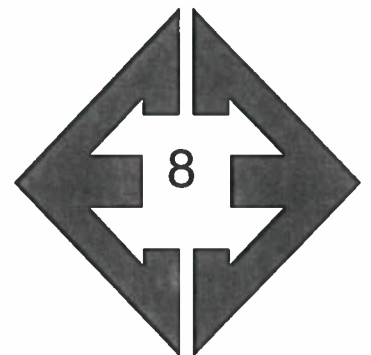

**Looking northwest
from the northeastern
portion of the site.**

July 10, 2017

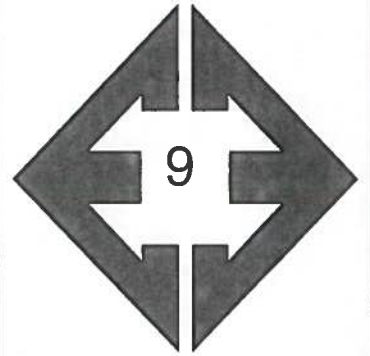

**Looking northwest
from the western
portion of the site.**

July 10, 2017

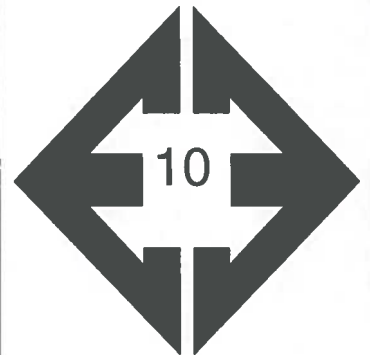

**Looking south from
the southwestern
portion of the site.**

July 10, 2017

**APPENDIX B: Test Boring Logs from the Profile Holes
and Test Pit Logs**

PROFILE HOLE NO. 1
 DATE DRILLED 7/10/2017
 Job # 170837

PROFILE HOLE NO. 2
 DATE DRILLED 7/10/2017
 CLIENT CARL TURSE
 LOCATION ROLLIN RIDGE ESTATES

REMARKS

DRY TO 9.5', 7/11/17
 CLAY, SANDY, TAN, FIRM,
 MOIST

Depth (ft)	Symbol	Samples	Blows per foot	Watercontent %	Soil Type
0 - 5	[Diagonal lines]		10	6.0	1
5 - 10	[Diagonal lines]		12	4.7	1
10 - 15	[Diagonal lines]		15	10.6	1
15 - 20	[Diagonal lines]				

REMARKS

DRY TO 10', 7/10/17
 CAVED TO 10', 7/11/17, DRY

Depth (ft)	Symbol	Samples	Blows per foot	Watercontent %	Soil Type
0 - 5	[Diagonal lines]		5	5.0	1
5 - 10	[Diagonal lines]		30	2.9	2
10 - 15	[Diagonal lines]		47	8.1	2
15 - 20	[Diagonal lines]		50	6.8	3
20 - 22	[Diagonal lines]		32*	12.8	3

* - WEATHERED ZONE



ENTECH
 ENGINEERING, INC.
 505 ELKTON DRIVE
 COLORADO SPRINGS, COLORADO 80907





















PROFILE HOLE LOG

DRAWN:	DATE:	CHECKED:	DATE:
		LLL	7/19/17

JOB NO.:
 170837
 FIG NO.:
 B-1

TEST PIT NO. 1
 DATE EXCAVATED 6/27/2017
 Job # 170837

TEST PIT NO. 2
 DATE EXCAVATED 6/27/2017
 CLIENT CARL TURSE
 LOCATION ROLLIN RIDGE ESTATES

REMARKS	Depth (ft)	Symbol	Samples	Soil Structure Shape	Soil Structure Grade	USDA Soil Type	REMARKS	Depth (ft)	Symbol	Samples	Soil Structure Shape	Soil Structure Grade	USDA Soil Type
topsoil, silty clay loam, brown	1			gr	m	3	topsoil, silty clay loam, brown	1			gr	m	3
silty clay loam, brown	2			gr	m	3	silty clay loam, light brown	2			gr	m	3
	3						sandy loam, fine to medium grained, tan	3			gr	m	2
	4							4					
	5							5					
	6							6					
	7							7					
	8							8					
	9							9					
	10							10					

Soil Structure Shape

- granular - gr
- platy - pl
- blocky - bl
- prismatic - pr
- single grain - sg
- massive - ma



ENTECH
ENGINEERING, INC.

505 ELKTON DRIVE
 COLORADO SPRINGS, COLORADO 80907

TEST PIT LOG

DRAWN:

DATE:

CHECKED:
LLL

DATE:
 7/19/17





















JOB NO.:
 170837

FIG NO.:

B-2

TEST PIT NO. 3
 DATE EXCAVATED 6/27/2017
 Job # 170837

TEST PIT NO. 4
 DATE EXCAVATED 6/27/2017
 CLIENT CARL TURSE
 LOCATION ROLLIN RIDGE ESTATES

REMARKS	Depth (ft)	Symbol	Samples	Soil Structure Shape	Soil Structure Grade	USDA Soil Type	REMARKS	Depth (ft)	Symbol	Samples	Soil Structure Shape	Soil Structure Grade	USDA Soil Type
topsoil, silty clay loam, brown	1			gr	m	3	topsoil, sandy loam. Brown	1			gr	m	2
silty clay loam, orange-brown	2			gr	m	3	sandy loam, fine to medium grained, orange-brown	2			gr	m	2
	3							3					
	4							4					
weathered clayey sandstone, fine to coarse grained, tan	5			ma		4A	sandy loam, fine to medium grained, orange-brown	5			gr	w	2A
	6							6					
	7							7					
	8							8					
	9							9					
	10							10					

Soil Structure Shape

- granular - gr
- platy - pl
- blocky - bl
- prismatic - pr
- single grain - sg
- massive - ma



**ENTECH
ENGINEERING, INC.**

505 ELKTON DRIVE
 COLORADO SPRINGS, COLORADO 80907

TEST PIT LOG

DRAWN: _____ DATE: _____ CHECKED: LLL DATE: 7/19/17

JOB NO.:
170837
 FIG NO.:
B-3

TEST PIT NO. 5
 DATE EXCAVATED 9/18/2017
 Job # 170837

TEST PIT NO. 6
 DATE EXCAVATED 9/18/2017
 CLIENT CARL TURSE
 LOCATION ROLLIN RIDGE ESTATES

REMARKS	Depth (ft)	Symbol	Samples	Soil Structure Shape	Soil Structure Grade	USDA Soil Type	REMARKS	Depth (ft)	Symbol	Samples	Soil Structure Shape	Soil Structure Grade	USDA Soil Type
topsoil, sandy loam, brown	1			gr	m	2	topsoil, sandy loam, brown	1			gr	w	2A
sandy loam, fine to coarse grained, light brown	2			gr	m	2	sandy loam, fine to coarse grained, light brown	2			gr	w	2A
	3							3					
	4							4					
	5							5					
weathered silty sandstone, fine to coarse grained, tan *signs of seasonally occurring groundwater at 6'	6			ma		3A		6					
	7							7					
	8							8					
	9						weathered silty sandstone, fine to coarse grained, buff *signs of seasonally occurring groundwater at 8'	9			ma		3A
	10							10					

Soil Structure Shape

- granular - gr
- platy - pl
- blocky - bi
- prismatic - pr
- single grain - sg
- massive - ma

Soil Structure Grade

- weak - w
- moderate - m
- strong - s
- loose - l



ENTECH
ENGINEERING, INC.

505 ELKTON DRIVE
 COLORADO SPRINGS, COLORADO 80907

TEST PIT LOG

DRAWN:	DATE:	CHECKED: LLL	DATE: 10/24/17
--------	-------	-----------------	-------------------

JOB NO.:
 170837
 FIG NO.:
 B-4

TEST PIT NO. 7
 DATE EXCAVATED 9/18/2017
 Job # 170837

TEST PIT NO. 8
 DATE EXCAVATED 9/18/2017
 CLIENT CARL TURSE
 LOCATION ROLLIN RIDGE ESTATES

REMARKS	Depth (ft)	Symbol	Samples	Soil Structure Shape	Soil Structure Grade	USDA Soil Type	REMARKS	Depth (ft)	Symbol	Samples	Soil Structure Shape	Soil Structure Grade	USDA Soil Type
topsoil, sandy loam, brown	1			gr	m	2	topsoil, sandy clay, brown	1			gr	m	4
sandy loam, fine to coarse grained, light brown	2			gr	m	2	sandy clay, brown	2			gr	m	4
	3							3					
	4							4					
	5							5					
weathered silty sandstone, fine to coarse grained, tan *signs of seasonally occurring groundwater at 6.5'	6			ma		3A	weathered silty sandstone, fine to coarse grained, tan *signs of seasonally occurring groundwater at 6'	6			ma		3A
	7							7					
	8							8					
	9							9					
	10							10					

Soil Structure Shape

granular - gr
 platy - pl
 blocky - bl
 prismatic - pr
 single grain - sg
 massive - ma

Soil Structure Grade

weak - w
 moderate - m
 strong - s
 loose - l



ENTECH
ENGINEERING, INC.

505 ELKTON DRIVE
 COLORADO SPRINGS, COLORADO 80907

TEST PIT LOG

DRAWN:

DATE:

CHECKED:
 LLL

DATE:
 10/24/17

JOB NO.:

170837

FIG NO.:

B-5

TEST PIT NO. 9
 DATE EXCAVATED 9/18/2017
 Job # 170837

TEST PIT NO. 10
 DATE EXCAVATED 9/18/2017
 CLIENT CARL TURSE
 LOCATION ROLLIN RIDGE ESTATES

REMARKS	Depth (ft)	Symbol	Samples	Soil Structure Shape	Soil Structure Grade	USDA Soil Type	REMARKS	Depth (ft)	Symbol	Samples	Soil Structure Shape	Soil Structure Grade	USDA Soil Type
topsoil, sandy clay loam, brown	1	[Symbol]		gr	m	3	topsoil, sandy clay loam, brown	1	[Symbol]		gr	m	3
sandy clay loam, light brown	2	[Symbol]		gr	m	3	sandy clay loam, brown	2	[Symbol]		gr	m	3
	3	[Symbol]						3	[Symbol]				
	4	[Symbol]						4	[Symbol]				
	5	[Symbol]						5	[Symbol]				
	6	[Symbol]						6	[Symbol]				
weathered very clayey sandstone, tan *signs of seasonally occurring groundwater at 6'	7	[Symbol]		ma		4A	weathered very clayey sandstone, tan *signs of seasonally occurring groundwater at 6'	7	[Symbol]		ma		4A
	8	[Symbol]						8	[Symbol]				
	9	[Symbol]						9	[Symbol]				
	10	[Symbol]						10	[Symbol]				

Soil Structure Shape
 granular - gr
 platy - pl
 blocky - bl
 prismatic - pr
 single grain - sg
 massive - ma

Soil Structure Grade
 weak - w
 moderate - m
 strong - s
 loose - l



ENTECH
ENGINEERING, INC.

505 ELKTON DRIVE
 COLORADO SPRINGS, COLORADO 80907

TEST PIT LOG

DRAWN:	DATE:	CHECKED: LLL	DATE: 10/24/17
--------	-------	-----------------	-------------------

JOB NO.:
170837
 FIG NO.:
B-6

TEST PIT NO. 11
 DATE EXCAVATED 9/18/2017
 Job # 170837

TEST PIT NO. 12
 DATE EXCAVATED 9/18/2017
 CLIENT CARL TURSE
 LOCATION ROLLIN RIDGE ESTATES

REMARKS	Depth (ft)	Symbol	Samples	Soil Structure Shape	Soil Structure Grade	USDA Soil Type	REMARKS	Depth (ft)	Symbol	Samples	Soil Structure Shape	Soil Structure Grade	USDA Soil Type
topsoil, sandy loam, brown	1			gr	m	2	topsoil, sandy loam, brown	1			gr	m	2
sandy loam, fine to coarse grained, light brown	2			gr	m	2	sandy loam, fine to coarse grained, light brown	2			gr	m	2
	3							3					
	4							4					
weathered silty sandstone, fine to coarse grained, tan *signs of seasonally occurring groundwater at 5'	5			ma		3A	weathered silty sandstone, fine to coarse grained, tan *signs of seasonally occurring groundwater at 5'	5			ma		3A
	6							6					
	7							7					
	8							8					
	9							9					
	10							10					

Soil Structure Shape

- granular - gr
- platy - pl
- blocky - bl
- prismatic - pr
- single grain - sg
- massive - ma

Soil Structure Grade

- weak - w
- moderate - m
- strong - s
- loose - l



ENTECH
ENGINEERING, INC.

505 ELKTON DRIVE
 COLORADO SPRINGS, COLORADO 80907

TEST PIT LOG

DRAWN:

DATE:

CHECKED:
 LLL

DATE:
 10/24/17

JOB NO.:

170837

FIG NO.:

B-7

TEST PIT NO. 13
 DATE EXCAVATED 9/18/2017
 Job # 170837

TEST PIT NO. 14
 DATE EXCAVATED 9/18/2017
 CLIENT CARL TURSE
 LOCATION ROLLIN RIDGE ESTATES

REMARKS	Depth (ft)	Symbol	Samples	Soil Structure Shape	Soil Structure Grade	USDA Soil Type	REMARKS	Depth (ft)	Symbol	Samples	Soil Structure Shape	Soil Structure Grade	USDA Soil Type
topsoil, sandy loam, brown	1			gr	w	2A	topsoil, sandy clay, brown	1			gr	m	4
weathered to formational silty sandstone, fine to coarse grained, tan	2			ma		3A	sandy clay, brown	2			gr	m	4
	3							3					
	4							4					
	5							5					
	6						weathered to formational silty sandstone, fine to coarse grained, tan *signs of seasonally occurring groundwater at 5'	6			ma		3A
	7							7					
	8							8					
	9							9					
	10							10					

Soil Structure Shape
 granular - gr
 platy - pl
 blocky - bl
 prismatic - pr
 single grain - sg
 massive - ma

Soil Structure Grade
 weak - w
 moderate - m
 strong - s
 loose - l



ENTECH
ENGINEERING, INC.
 505 ELKTON DRIVE
 COLORADO SPRINGS, COLORADO 80907

TEST PIT LOG

DRAWN:	DATE:	CHECKED: LLL	DATE: 10/24/17
--------	-------	-----------------	-------------------

JOB NO.:
 170837
 FIG NO.:
 B-8

APPENDIX C: Laboratory Test Results

<u>UNIFIED CLASSIFICATION</u>	CL	<u>CLIENT</u>	CARL TURSE
<u>SOIL TYPE #</u>	1	<u>PROJECT</u>	ROLLIN RIDGE ESTATES
<u>TEST BORING #</u>	1	<u>JOB NO.</u>	170837
<u>DEPTH (FT)</u>	2-3	<u>TEST BY</u>	BL

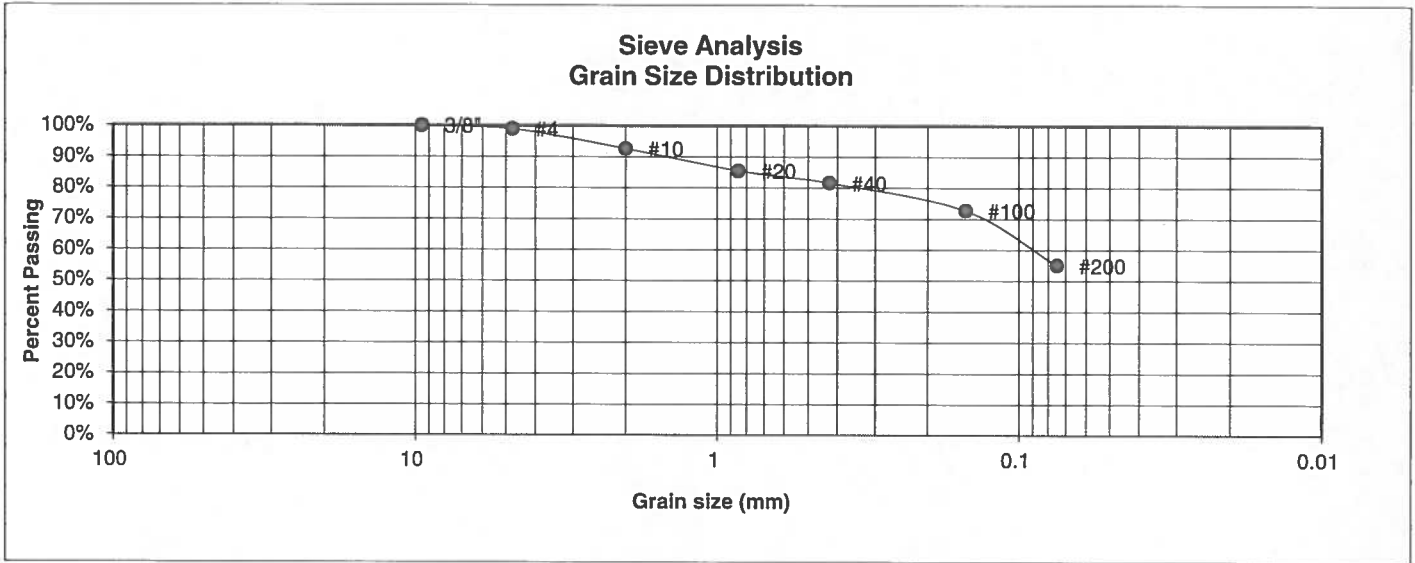

<u>U.S. Sieve #</u>	<u>Percent Finer</u>
3"	
1 1/2"	
3/4"	
1/2"	
3/8"	100.0%
4	98.9%
10	92.7%
20	85.5%
40	81.6%
100	72.7%
200	55.0%

Atterberg Limits
 Plastic Limit
 Liquid Limit
 Plastic Index

Swell
 Moisture at start
 Moisture at finish
 Moisture increase
 Initial dry density (pcf)
 Swell (psf)



**ENTECH
ENGINEERING, INC.**

505 ELKTON DRIVE
COLORADO SPRINGS, COLORADO 80907

**LABORATORY TEST
RESULTS**

<u>DRAWN:</u>	<u>DATE:</u>	<u>CHECKED:</u> LLL	<u>DATE:</u> 10/25/17
---------------	--------------	------------------------	--------------------------

JOB NO.:
170837

FIG NO.:
C-1

<u>UNIFIED CLASSIFICATION</u>	CL	<u>CLIENT</u>	CARL TURSE
<u>SOIL TYPE #</u>	1	<u>PROJECT</u>	ROLLIN RIDGE ESTATES
<u>TEST BORING #</u>	TP-1	<u>JOB NO.</u>	170837
<u>DEPTH (FT)</u>	2-3	<u>TEST BY</u>	BL

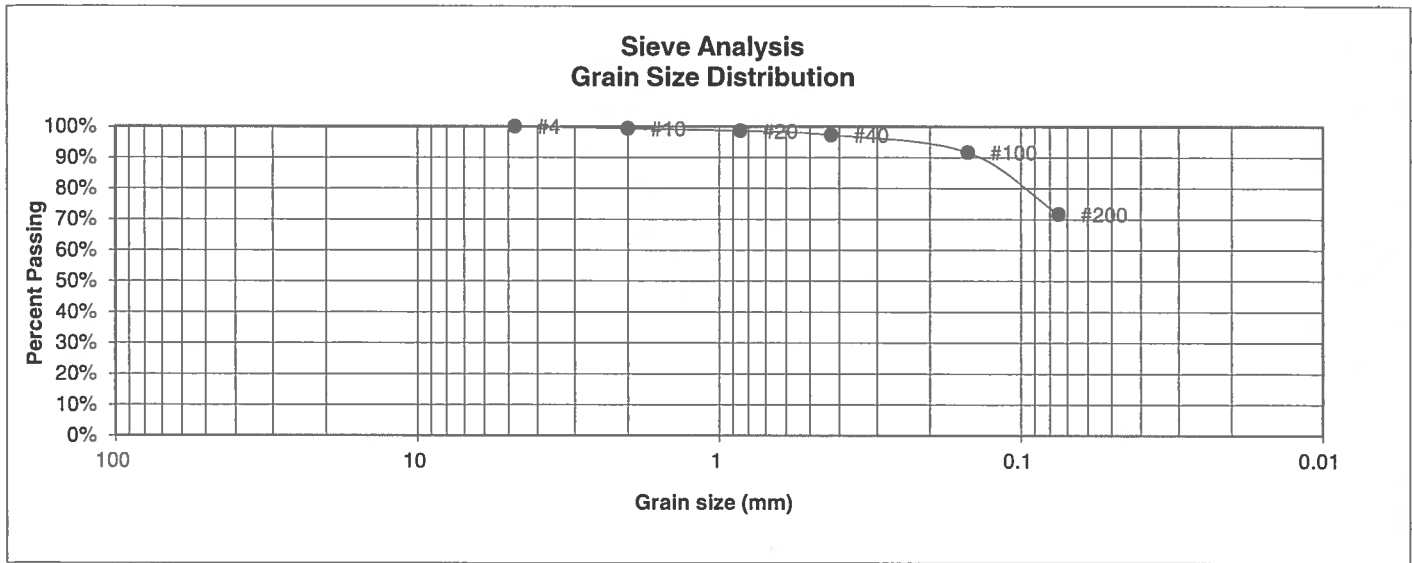

<u>U.S. Sieve #</u>	<u>Percent Finer</u>
3"	
1 1/2"	
3/4"	
1/2"	
3/8"	
4	100.0%
10	99.4%
20	98.6%
40	97.3%
100	91.7%
200	71.7%

Atterberg Limits
 Plastic Limit
 Liquid Limit
 Plastic Index

<u>Swell</u>	
Moisture at start	8.4%
Moisture at finish	20.9%
Moisture increase	12.6%
Initial dry density (pcf)	99
Swell (psf)	430



ENTECH
ENGINEERING, INC.

505 ELKTON DRIVE
 COLORADO SPRINGS, COLORADO 80907

**LABORATORY TEST
 RESULTS**

<u>DRAWN:</u>	<u>DATE:</u>	<u>CHECKED:</u> LLL	<u>DATE:</u> 10/25/17
---------------	--------------	------------------------	--------------------------

JOB NO.:
170837

FIG NO.:
C-2

<u>UNIFIED CLASSIFICATION</u>	CL	<u>CLIENT</u>	CARL TURSE
<u>SOIL TYPE #</u>	1	<u>PROJECT</u>	ROLLIN RIDGE ESTATES
<u>TEST BORING #</u>	TP-1	<u>JOB NO.</u>	170837
<u>DEPTH (FT)</u>	5-6	<u>TEST BY</u>	BL

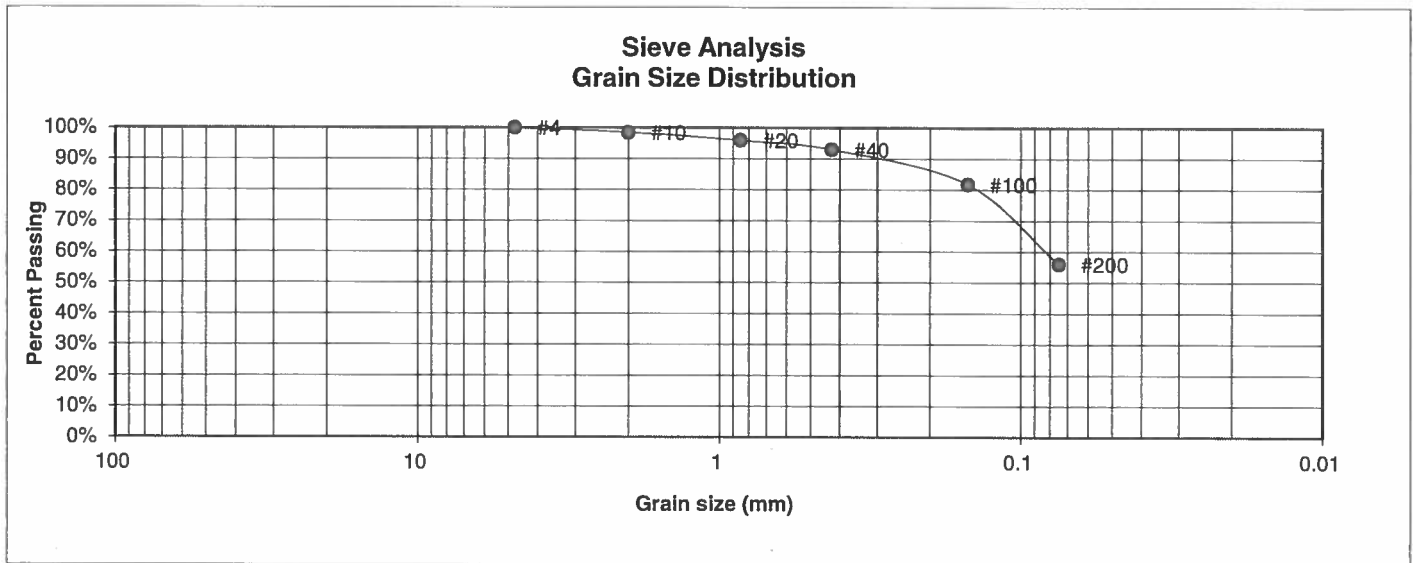

<u>U.S. Sieve #</u>	<u>Percent Finer</u>	<u>Atterberg Limits</u>
3"		Plastic Limit
1 1/2"		Liquid Limit
3/4"		Plastic Index
1/2"		
3/8"		
4	100.0%	<u>Swell</u>
10	98.5%	Moisture at start
20	95.9%	Moisture at finish
40	93.0%	Moisture increase
100	81.8%	Initial dry density (pcf)
200	56.0%	Swell (psf)



ENTECH
ENGINEERING, INC.
505 ELKTON DRIVE
COLORADO SPRINGS, COLORADO 80907

**LABORATORY TEST
RESULTS**

<u>DRAWN:</u>	<u>DATE:</u>	<u>CHECKED:</u> LLL	<u>DATE:</u> 10/25/17
---------------	--------------	------------------------	--------------------------

JOB NO.:
170837

FIG NO.:

L-3

<u>UNIFIED CLASSIFICATION</u>	CL	<u>CLIENT</u>	CARL TURSE
<u>SOIL TYPE #</u>	1	<u>PROJECT</u>	ROLLIN RIDGE ESTATES
<u>TEST BORING #</u>	TP-2	<u>JOB NO.</u>	170837
<u>DEPTH (FT)</u>	2-3	<u>TEST BY</u>	BL

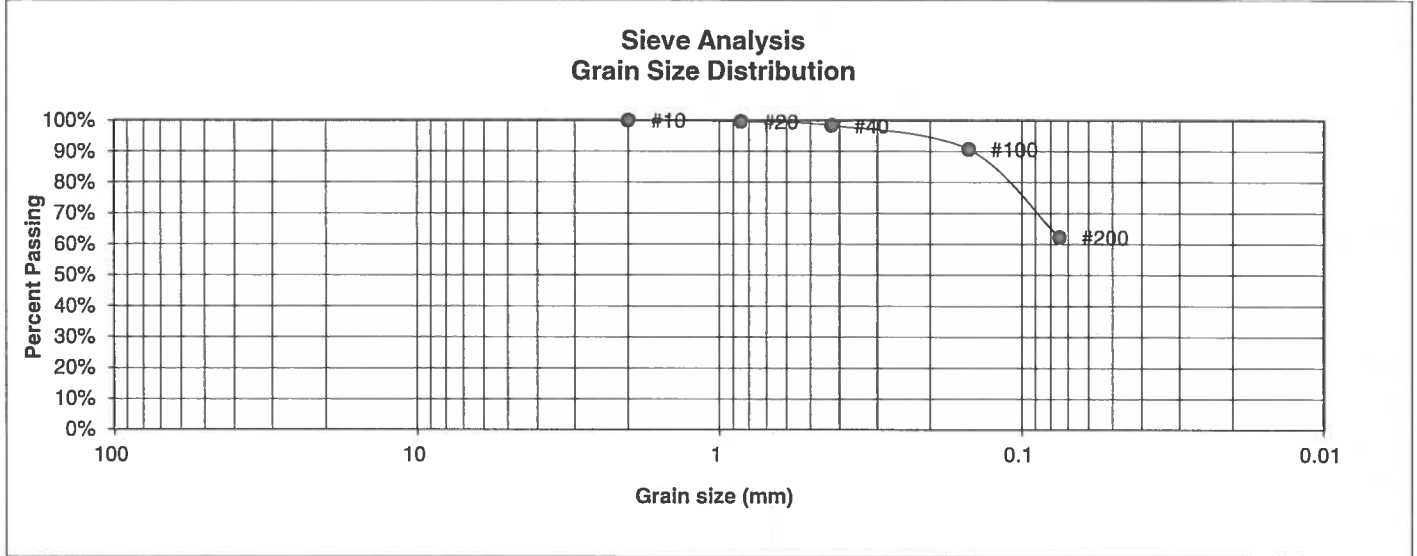

<u>U.S. Sieve #</u>	<u>Percent Finer</u>
3"	
1 1/2"	
3/4"	
1/2"	
3/8"	
4	
10	100.0%
20	99.6%
40	98.3%
100	90.7%
200	62.2%

- Atterberg Limits
 Plastic Limit
 Liquid Limit
 Plastic Index
- Swell
 Moisture at start
 Moisture at finish
 Moisture increase
 Initial dry density (pcf)
 Swell (psf)



**ENTECH
ENGINEERING, INC.**
 505 ELKTON DRIVE
 COLORADO SPRINGS, COLORADO 80907

**LABORATORY TEST
RESULTS**

<u>DRAWN:</u>	<u>DATE:</u>	<u>CHECKED:</u> LLL	<u>DATE:</u> 10/25/17
---------------	--------------	------------------------	--------------------------

JOB NO.:
170837

 FIG NO.:
C-4

<u>UNIFIED CLASSIFICATION</u>	CL	<u>CLIENT</u>	CARL TURSE
<u>SOIL TYPE #</u>	1	<u>PROJECT</u>	ROLLIN RIDGE ESTATES
<u>TEST BORING #</u>	TP-3	<u>JOB NO.</u>	170837
<u>DEPTH (FT)</u>	2-3	<u>TEST BY</u>	BL

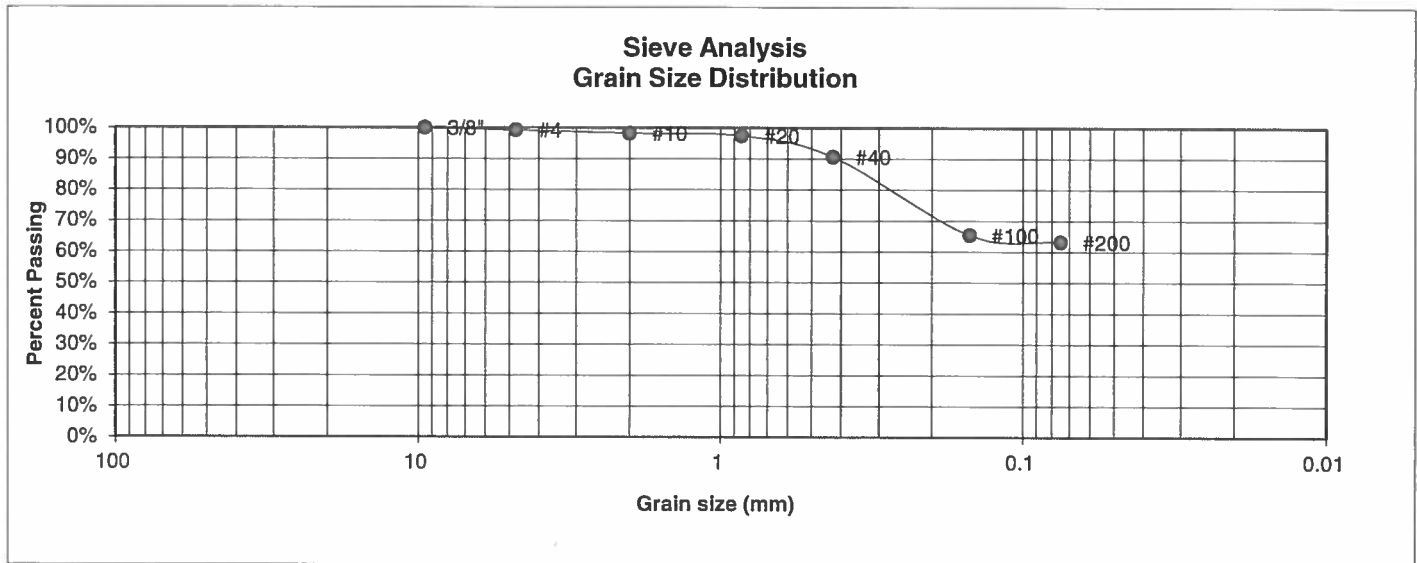

<u>U.S. Sieve #</u>	<u>Percent Finer</u>
3"	
1 1/2"	
3/4"	
1/2"	
3/8"	100.0%
4	99.3%
10	98.3%
20	97.4%
40	90.6%
100	65.4%
200	63.2%

Atterberg Limits
 Plastic Limit
 Liquid Limit
 Plastic Index

Swell
 Moisture at start
 Moisture at finish
 Moisture increase
 Initial dry density (pcf)
 Swell (psf)



**ENTECH
ENGINEERING, INC.**
 505 ELKTON DRIVE
 COLORADO SPRINGS, COLORADO 80907

**LABORATORY TEST
RESULTS**

<u>DRAWN:</u>	<u>DATE:</u>	<u>CHECKED:</u> LLL	<u>DATE:</u> 10/25/17
---------------	--------------	------------------------	--------------------------

JOB NO.:
170837

FIG NO.:
C-5

<u>UNIFIED CLASSIFICATION</u>	CL	<u>CLIENT</u>	CARL TURSE
<u>SOIL TYPE #</u>	1	<u>PROJECT</u>	ROLLIN RIDGE ESTATES
<u>TEST BORING #</u>	TP-5	<u>JOB NO.</u>	170837
<u>DEPTH (FT)</u>	2-3	<u>TEST BY</u>	BL

**Sieve Analysis
Grain Size Distribution**

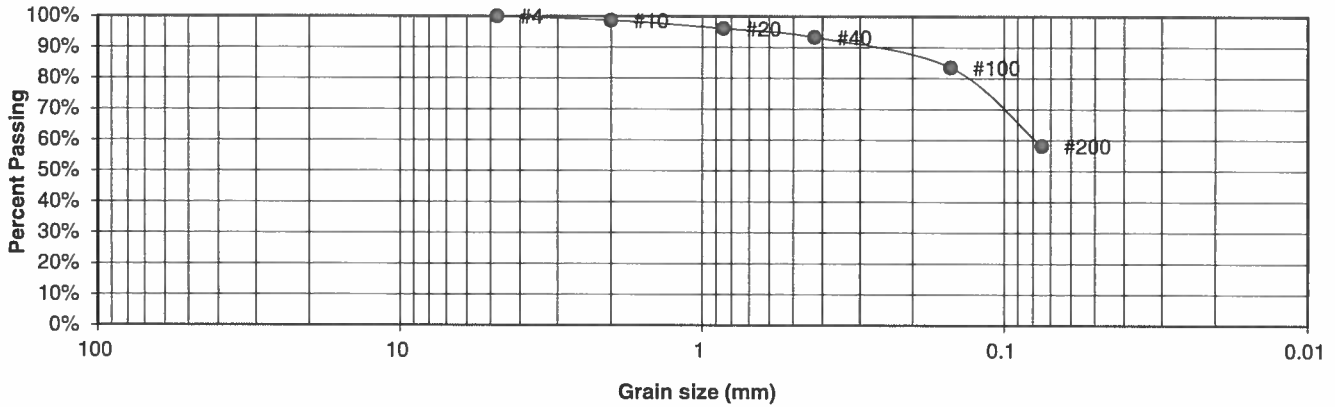

<u>U.S. Sieve #</u>	<u>Percent Finer</u>
3"	
1 1/2"	
3/4"	
1/2"	
3/8"	
4	100.0%
10	98.7%
20	96.1%
40	93.3%
100	83.6%
200	58.2%

Atterberg Limits
 Plastic Limit
 Liquid Limit
 Plastic Index

Swell
 Moisture at start
 Moisture at finish
 Moisture increase
 Initial dry density (pcf)
 Swell (psf)



**ENTECH
ENGINEERING, INC.**

505 ELKTON DRIVE
COLORADO SPRINGS, COLORADO 80907

**LABORATORY TEST
RESULTS**

<u>DRAWN:</u>	<u>DATE:</u>	<u>CHECKED:</u>	<u>DATE:</u>
		LLL	10/25/17

JOB NO.:
170837

FIG NO.:
L-6

<u>UNIFIED CLASSIFICATION</u>	CL	<u>CLIENT</u>	CARL TURSE
<u>SOIL TYPE #</u>	1	<u>PROJECT</u>	ROLLIN RIDGE ESTATES
<u>TEST BORING #</u>	TP-10	<u>JOB NO.</u>	170837
<u>DEPTH (FT)</u>	6-8	<u>TEST BY</u>	BL

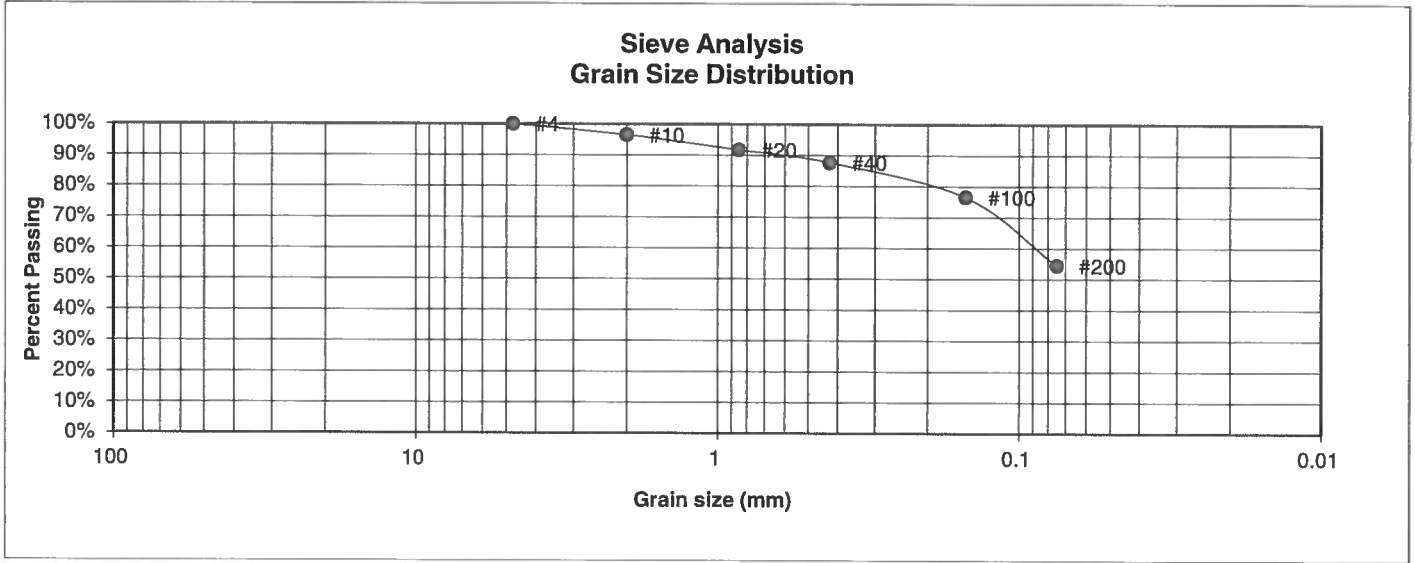

<u>U.S. Sieve #</u>	<u>Percent Finer</u>
3"	
1 1/2"	
3/4"	
1/2"	
3/8"	
4	100.0%
10	96.5%
20	91.7%
40	87.7%
100	76.5%
200	54.5%

Atterberg Limits
 Plastic Limit
 Liquid Limit
 Plastic Index

Swell
 Moisture at start
 Moisture at finish
 Moisture increase
 Initial dry density (pcf)
 Swell (psf)



ENTECH
ENGINEERING, INC.

505 ELKTON DRIVE
 COLORADO SPRINGS, COLORADO 80907

**LABORATORY TEST
 RESULTS**

<u>DRAWN:</u>	<u>DATE:</u>	<u>CHECKED:</u> LLL	<u>DATE:</u> 10/25/17
---------------	--------------	------------------------	--------------------------

JOB NO.:
170837

FIG NO.:
C-7

UNIFIED CLASSIFICATION	CL	CLIENT	CARL TURSE
SOIL TYPE #	1	PROJECT	ROLLIN RIDGE ESTATES
TEST BORING #	TP-14	JOB NO.	170837
DEPTH (FT)	3-4	TEST BY	BL

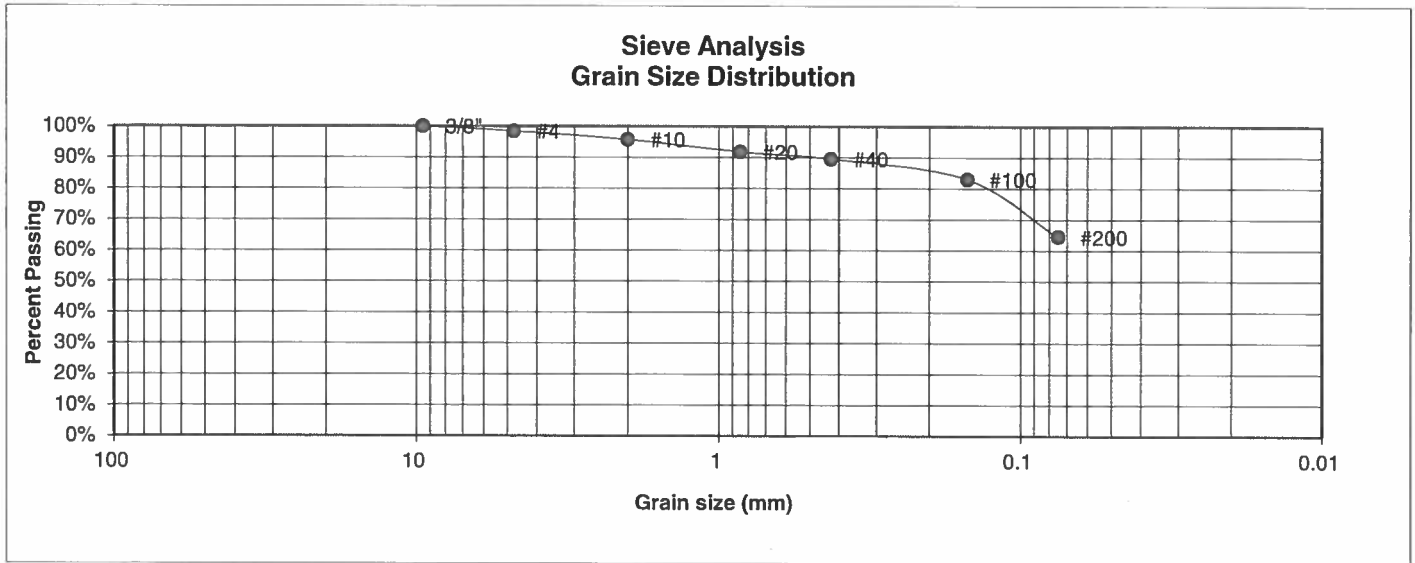

U.S. Sieve #	Percent Finer
3"	
1 1/2"	
3/4"	
1/2"	
3/8"	100.0%
4	98.5%
10	95.7%
20	91.8%
40	89.6%
100	83.0%
200	64.5%

Atterberg Limits
 Plastic Limit
 Liquid Limit
 Plastic Index

Swell
 Moisture at start
 Moisture at finish
 Moisture increase
 Initial dry density (pcf)
 Swell (psf)



**ENTECH
ENGINEERING, INC.**
 505 ELKTON DRIVE
 COLORADO SPRINGS, COLORADO 80907

**LABORATORY TEST
RESULTS**

DRAWN:	DATE:	CHECKED: LLL	DATE: 10/25/17
--------	-------	-----------------	-------------------

JOB NO.:
170837

FIG NO.:
C-8

<u>UNIFIED CLASSIFICATION</u>	SC	<u>CLIENT</u>	CARL TURSE
<u>SOIL TYPE #</u>	2	<u>PROJECT</u>	ROLLIN RIDGE ESTATES
<u>TEST BORING #</u>	2	<u>JOB NO.</u>	170837
<u>DEPTH (FT)</u>	5	<u>TEST BY</u>	BL

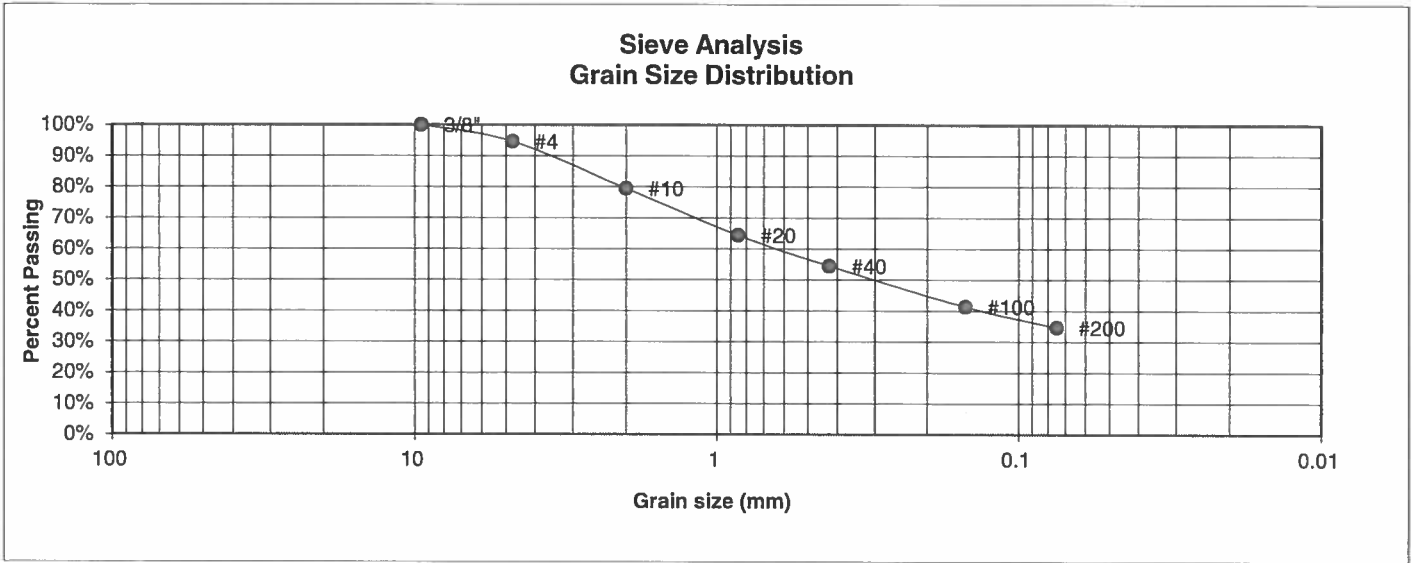

U.S. Sieve #	Percent Finer
3"	
1 1/2"	
3/4"	
1/2"	
3/8"	100.0%
4	94.7%
10	79.5%
20	64.4%
40	54.5%
100	41.4%
200	34.6%

Atterberg Limits
 Plastic Limit
 Liquid Limit
 Plastic Index

<u>Swell</u>	
Moisture at start	4.2%
Moisture at finish	9.5%
Moisture increase	5.3%
Initial dry density (pcf)	211
Swell (psf)	556



**ENTECH
ENGINEERING, INC.**

505 ELKTON DRIVE
COLORADO SPRINGS, COLORADO 80907

**LABORATORY TEST
RESULTS**

DRAWN:	DATE:	CHECKED: LLL	DATE: 10/25/17
--------	-------	-----------------	-------------------

JOB NO.:
170837

FIG NO.:
C-9

UNIFIED CLASSIFICATION	SC	CLIENT	CARL TURSE
SOIL TYPE #	2	PROJECT	ROLLIN RIDGE ESTATES
TEST BORING #	TP-4	JOB NO.	170837
DEPTH (FT)	5-6	TEST BY	BL

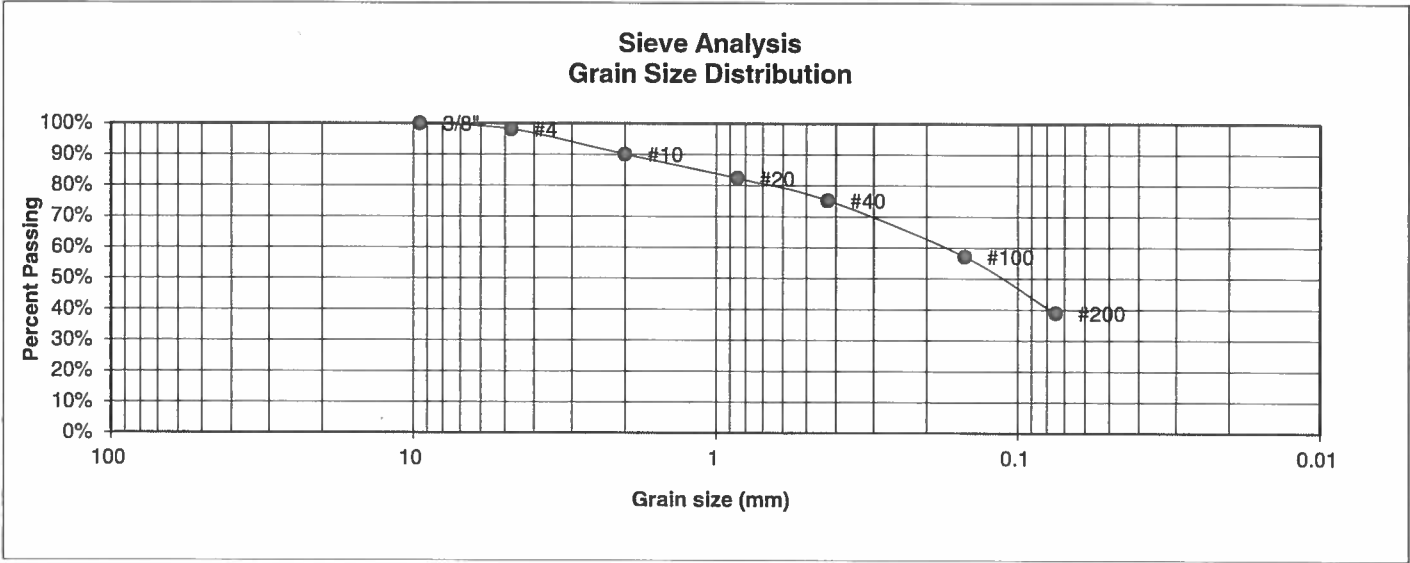

U.S. Sieve #	Percent Finer
3"	
1 1/2"	
3/4"	
1/2"	
3/8"	100.0%
4	98.2%
10	90.1%
20	82.3%
40	75.2%
100	57.1%
200	38.9%

Atterberg Limits
 Plastic Limit
 Liquid Limit
 Plastic Index

Swell
 Moisture at start
 Moisture at finish
 Moisture increase
 Initial dry density (pcf)
 Swell (psf)



**ENTECH
ENGINEERING, INC.**
 505 ELKTON DRIVE
 COLORADO SPRINGS, COLORADO 80907

**LABORATORY TEST
RESULTS**

DRAWN:	DATE:	CHECKED: LLL	DATE: 10/25/17
---------------	--------------	------------------------	--------------------------

JOB NO.:
170837

FIG NO.:
C-10

<u>UNIFIED CLASSIFICATION</u>	SM-SW	<u>CLIENT</u>	CARL TURSE
<u>SOIL TYPE #</u>	2	<u>PROJECT</u>	ROLLIN RIDGE ESTATES
<u>TEST BORING #</u>	TP-5	<u>JOB NO.</u>	170837
<u>DEPTH (FT)</u>	6-8	<u>TEST BY</u>	BL

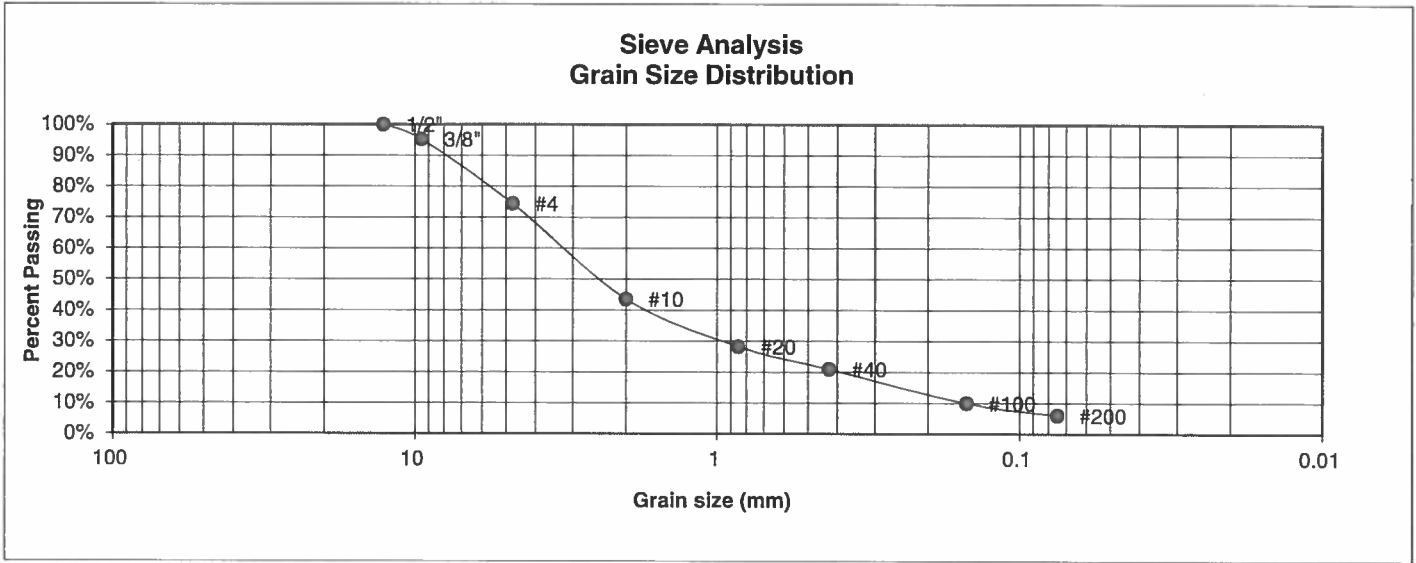

<u>U.S. Sieve #</u>	<u>Percent Finer</u>
3"	
1 1/2"	
3/4"	
1/2"	100.0%
3/8"	95.2%
4	74.4%
10	43.6%
20	28.2%
40	20.9%
100	10.0%
200	6.0%

Atterberg Limits
 Plastic Limit
 Liquid Limit
 Plastic Index

Swell
 Moisture at start
 Moisture at finish
 Moisture increase
 Initial dry density (pcf)
 Swell (psf)



**ENTECH
ENGINEERING, INC.**

505 ELKTON DRIVE
COLORADO SPRINGS, COLORADO 80907

**LABORATORY TEST
RESULTS**

DRAWN:	DATE:	CHECKED: LLL	DATE: 10/25/17
--------	-------	-----------------	-------------------

JOB NO.:
170837

FIG NO.:
C-11

<u>UNIFIED CLASSIFICATION</u>	SC	<u>CLIENT</u>	CARL TURSE
<u>SOIL TYPE #</u>	2	<u>PROJECT</u>	ROLLIN RIDGE ESTATES
<u>TEST BORING #</u>	TP-6	<u>JOB NO.</u>	170837
<u>DEPTH (FT)</u>	3-8	<u>TEST BY</u>	BL

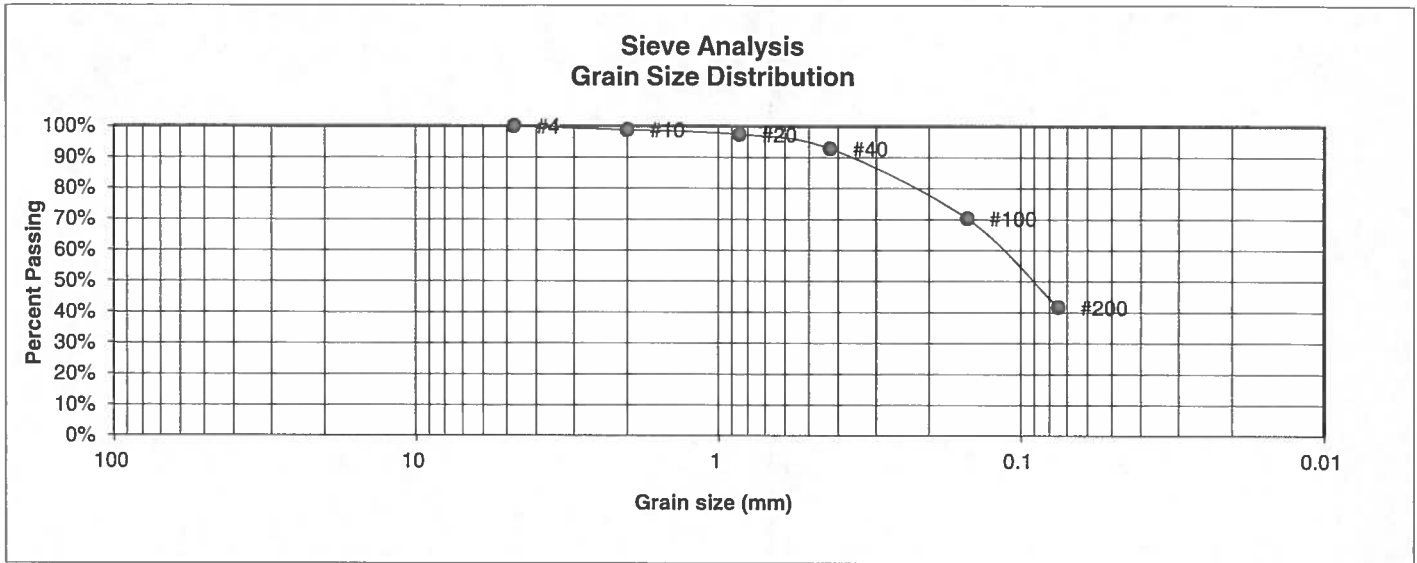

U.S. Sieve #	Percent Finer
3"	
1 1/2"	
3/4"	
1/2"	
3/8"	
4	100.0%
10	98.9%
20	97.4%
40	92.8%
100	70.3%
200	41.7%

Atterberg Limits
 Plastic Limit
 Liquid Limit
 Plastic Index

Swell
 Moisture at start
 Moisture at finish
 Moisture increase
 Initial dry density (pcf)
 Swell (psf)



**ENTECH
ENGINEERING, INC.**
 505 ELKTON DRIVE
 COLORADO SPRINGS, COLORADO 80907

**LABORATORY TEST
RESULTS**

DRAWN:	DATE:	CHECKED: LLL	DATE: 10/25/17
--------	-------	-----------------	-------------------

JOB NO.:
170837
 FIG NO.:
C-12

<u>UNIFIED CLASSIFICATION</u>	SM	<u>CLIENT</u>	CARL TURSE
<u>SOIL TYPE #</u>	2	<u>PROJECT</u>	ROLLIN RIDGE ESTATES
<u>TEST BORING #</u>	TP-11	<u>JOB NO.</u>	170837
<u>DEPTH (FT)</u>	4-6	<u>TEST BY</u>	BL

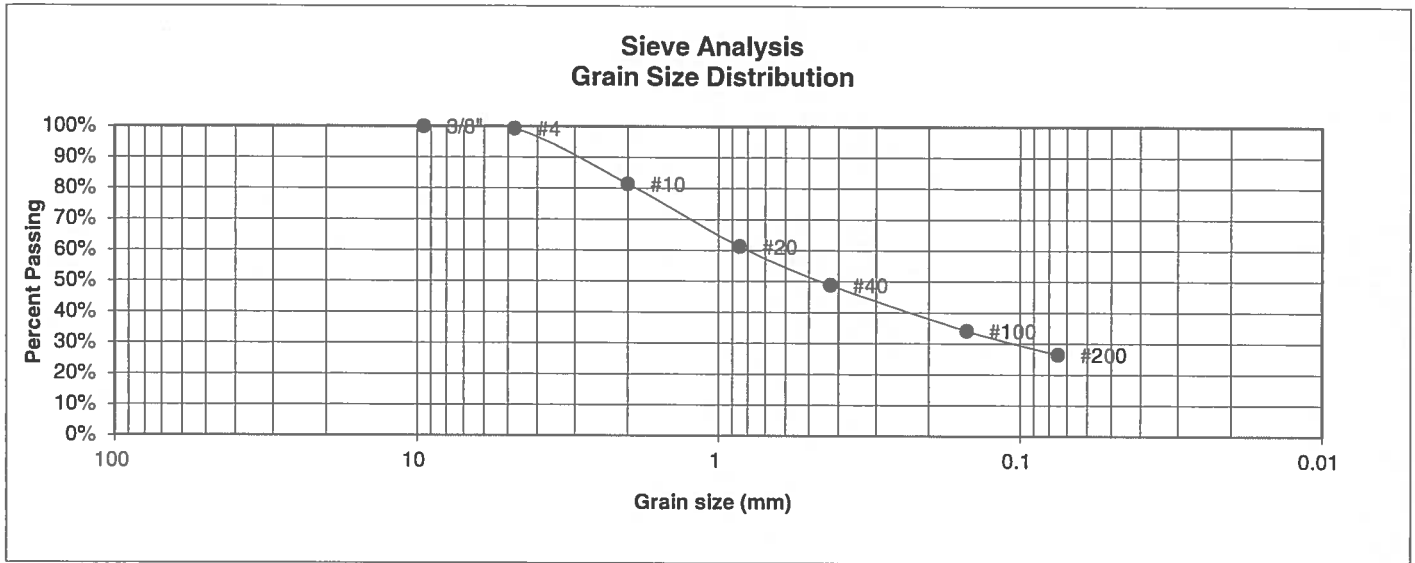

<u>U.S. Sieve #</u>	<u>Percent Finer</u>
3"	
1 1/2"	
3/4"	
1/2"	
3/8"	100.0%
4	99.2%
10	81.5%
20	61.3%
40	48.8%
100	34.2%
200	26.4%

Atterberg Limits
 Plastic Limit
 Liquid Limit
 Plastic Index

Swell
 Moisture at start
 Moisture at finish
 Moisture increase
 Initial dry density (pcf)
 Swell (psf)



**ENTECH
ENGINEERING, INC.**

505 ELKTON DRIVE
COLORADO SPRINGS, COLORADO 80907

**LABORATORY TEST
RESULTS**

<u>DRAWN:</u>	<u>DATE:</u>	<u>CHECKED:</u> LLL	<u>DATE:</u> 10/25/17
---------------	--------------	------------------------	--------------------------

JOB NO.:
170837

FIG NO.:
C-13

<u>UNIFIED CLASSIFICATION</u>	SM	<u>CLIENT</u>	CARL TURSE
<u>SOIL TYPE #</u>	3	<u>PROJECT</u>	ROLLIN RIDGE ESTATES
<u>TEST BORING #</u>	2	<u>JOB NO.</u>	170837
<u>DEPTH (FT)</u>	15	<u>TEST BY</u>	BL

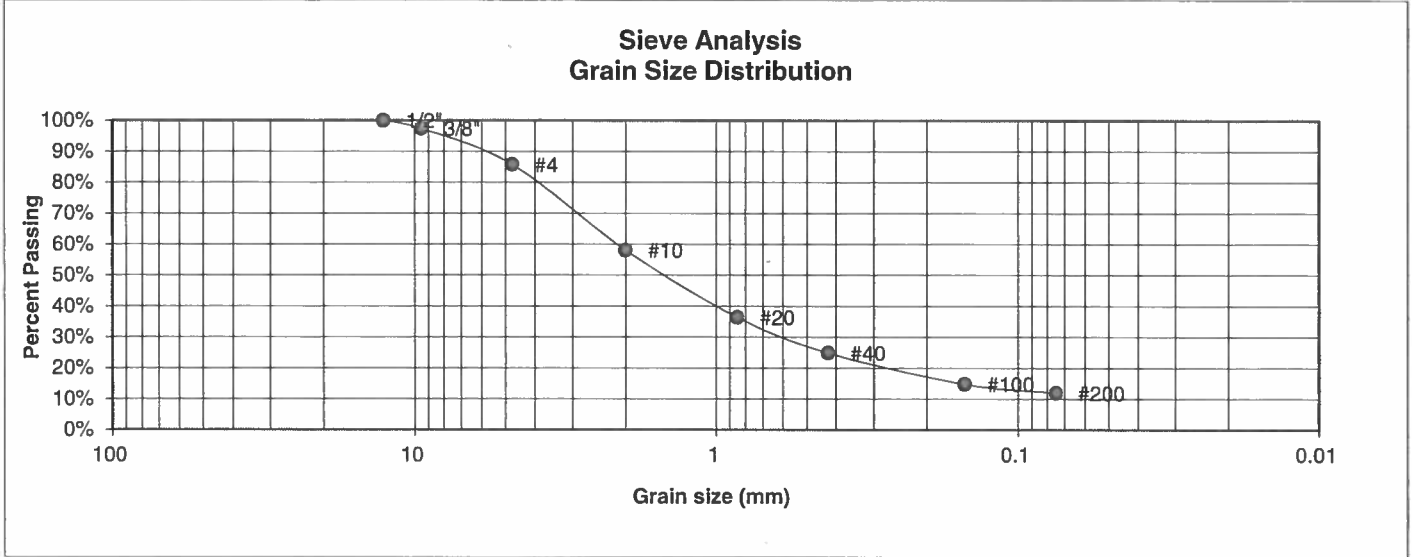

<u>U.S. Sieve #</u>	<u>Percent Finer</u>
3"	
1 1/2"	
3/4"	
1/2"	100.0%
3/8"	97.4%
4	85.8%
10	58.1%
20	36.4%
40	24.9%
100	14.8%
200	11.9%

Atterberg Limits
 Plastic Limit
 Liquid Limit
 Plastic Index

Swell
 Moisture at start
 Moisture at finish
 Moisture increase
 Initial dry density (pcf)
 Swell (psf)



ENTECH
ENGINEERING, INC.

505 ELKTON DRIVE
 COLORADO SPRINGS, COLORADO 80907

**LABORATORY TEST
 RESULTS**

DRAWN:

DATE:

CHECKED:

DATE:

LLL

10/25/17

JOB NO.:
 170837

FIG NO.:

C-14

<u>UNIFIED CLASSIFICATION</u>	SM	<u>CLIENT</u>	CARL TURSE
<u>SOIL TYPE #</u>	3	<u>PROJECT</u>	ROLLIN RIDGE ESTATES
<u>TEST BORING #</u>	TP-3	<u>JOB NO.</u>	170837
<u>DEPTH (FT)</u>	5-6	<u>TEST BY</u>	BL

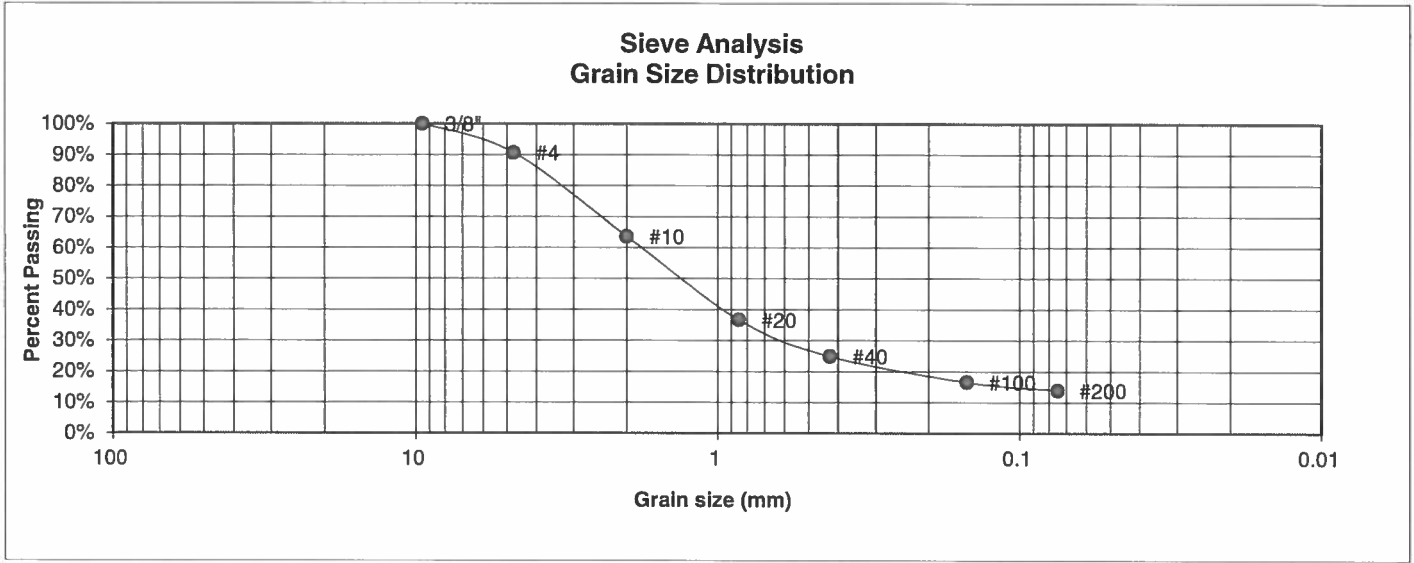

<u>U.S. Sieve #</u>	<u>Percent Finer</u>	<u>Atterberg Limits</u>
3"		Plastic Limit
1 1/2"		Liquid Limit
3/4"		Plastic Index
1/2"		
3/8"	100.0%	
4	90.7%	<u>Swell</u>
10	63.6%	Moisture at start
20	36.7%	Moisture at finish
40	24.9%	Moisture increase
100	16.6%	Initial dry density (pcf)
200	13.9%	Swell (psf)



ENTECH
ENGINEERING, INC.
505 ELKTON DRIVE
COLORADO SPRINGS, COLORADO 80907

**LABORATORY TEST
RESULTS**

DRAWN:	DATE:	CHECKED:	DATE:
		LLL	10/25/17

JOB NO.:
170837

FIG NO.:
C-15

UNIFIED CLASSIFICATION	SM-SW	CLIENT	CARL TURSE
SOIL TYPE #	3	PROJECT	ROLLIN RIDGE ESTATES
TEST BORING #	TP-7	JOB NO.	170837
DEPTH (FT)	6-8	TEST BY	BL

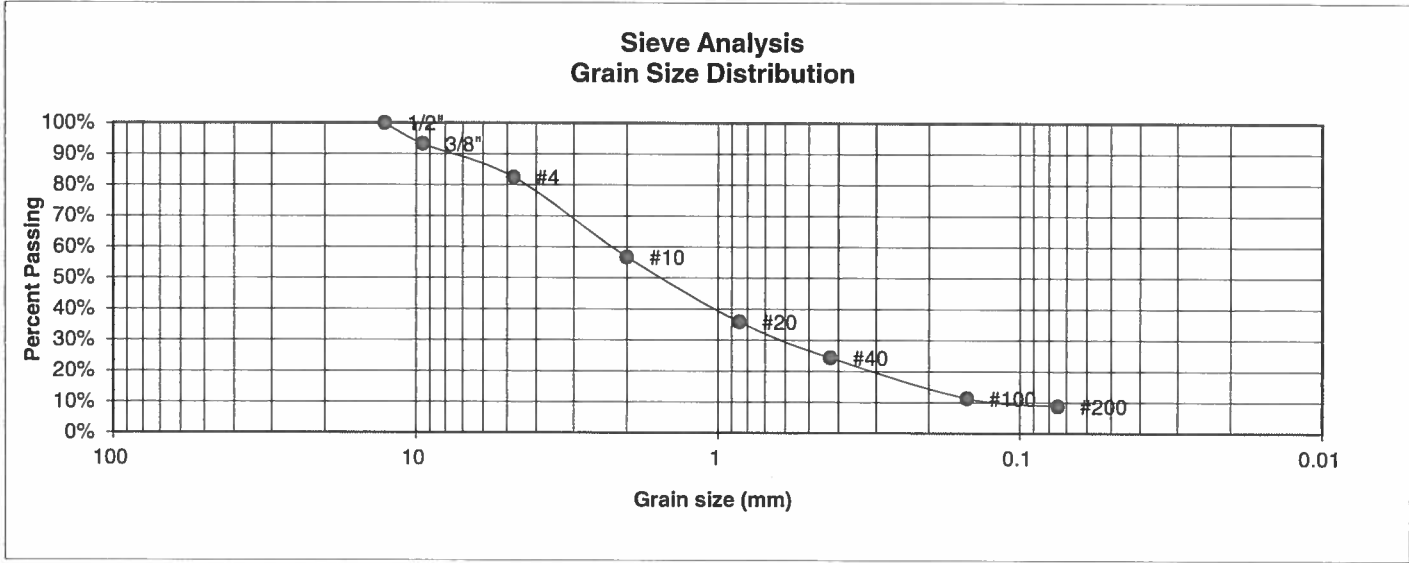

U.S. Sieve #	Percent Finer
3"	
1 1/2"	
3/4"	
1/2"	100.0%
3/8"	93.2%
4	82.5%
10	56.8%
20	35.9%
40	24.3%
100	11.3%
200	8.8%

Atterberg Limits
 Plastic Limit
 Liquid Limit
 Plastic Index

Swell
 Moisture at start
 Moisture at finish
 Moisture increase
 Initial dry density (pcf)
 Swell (psf)



ENTECH ENGINEERING, INC.
 505 ELKTON DRIVE
 COLORADO SPRINGS, COLORADO 80907

LABORATORY TEST RESULTS

DRAWN:	DATE:	CHECKED:	DATE:
		LLL	10/25/17

JOB NO.: 170837
 FIG NO.: C-16

<u>UNIFIED CLASSIFICATION</u>	SM	<u>CLIENT</u>	CARL TURSE
<u>SOIL TYPE #</u>	3	<u>PROJECT</u>	ROLLIN RIDGE ESTATES
<u>TEST BORING #</u>	TP-8	<u>JOB NO.</u>	170837
<u>DEPTH (FT)</u>	6-8	<u>TEST BY</u>	BL

**Sieve Analysis
Grain Size Distribution**

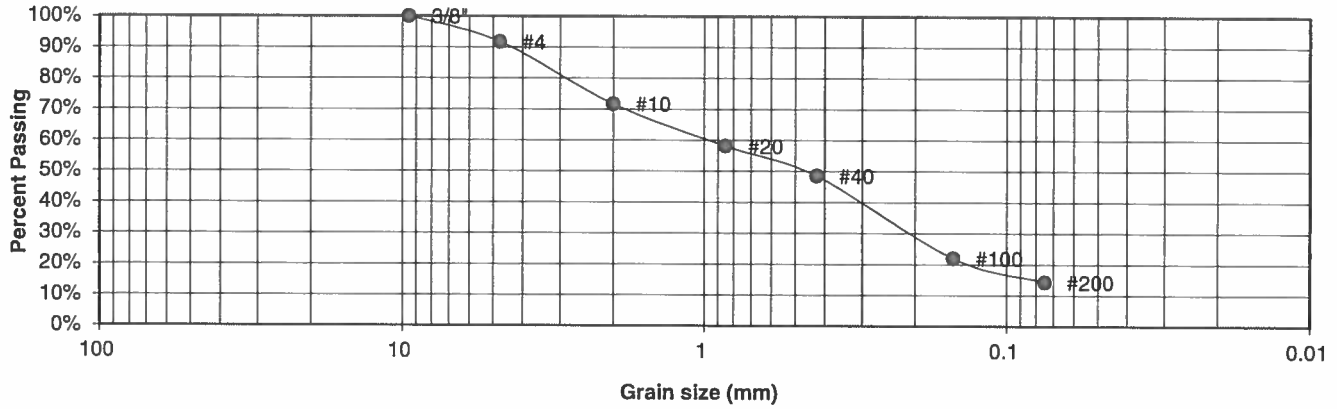

U.S. Sieve #	Percent Finer
3"	
1 1/2"	
3/4"	
1/2"	
3/8"	100.0%
4	91.7%
10	71.7%
20	58.1%
40	48.5%
100	22.0%
200	14.3%

Atterberg Limits
 Plastic Limit
 Liquid Limit
 Plastic Index

Swell
 Moisture at start
 Moisture at finish
 Moisture increase
 Initial dry density (pcf)
 Swell (psf)



**ENTECH
ENGINEERING, INC.**
 505 ELKTON DRIVE
 COLORADO SPRINGS, COLORADO 80907

**LABORATORY TEST
RESULTS**

DRAWN:	DATE:	CHECKED: L L L	DATE: 10/25/17
--------	-------	-------------------	-------------------

JOB NO.:
170837

FIG NO.:
C-17

<u>UNIFIED CLASSIFICATION</u>	SM	<u>CLIENT</u>	CARL TURSE
<u>SOIL TYPE #</u>	3	<u>PROJECT</u>	ROLLIN RIDGE ESTATES
<u>TEST BORING #</u>	TP-12	<u>JOB NO.</u>	170837
<u>DEPTH (FT)</u>	5-6	<u>TEST BY</u>	BL

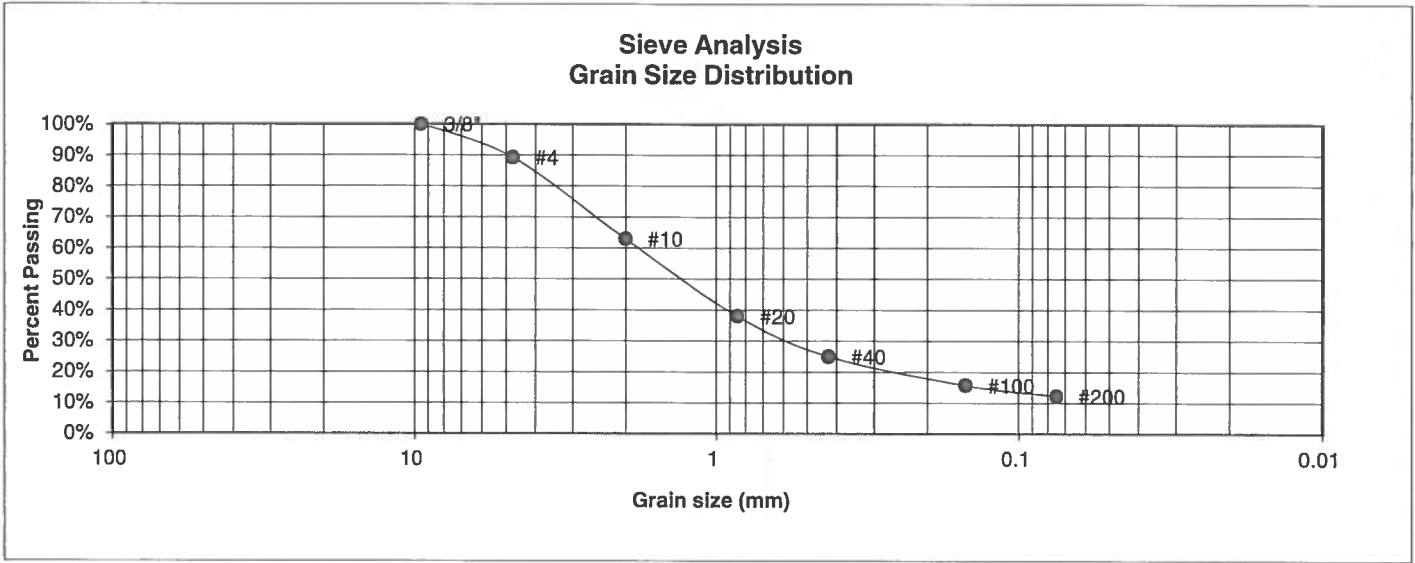

U.S. Sieve #	Percent Finer
3"	
1 1/2"	
3/4"	
1/2"	
3/8"	100.0%
4	89.2%
10	62.9%
20	38.0%
40	25.0%
100	15.7%
200	12.2%

Atterberg Limits
 Plastic Limit
 Liquid Limit
 Plastic Index

Swell
 Moisture at start
 Moisture at finish
 Moisture increase
 Initial dry density (pcf)
 Swell (psf)



ENTECH
ENGINEERING, INC.

505 ELKTON DRIVE
 COLORADO SPRINGS, COLORADO 80907

**LABORATORY TEST
 RESULTS**

DRAWN:	DATE:	CHECKED: LLL	DATE: 10/25/17
--------	-------	-----------------	-------------------

JOB NO.:
170837

FIG NO.:
C-18

UNIFIED CLASSIFICATION	SM	CLIENT	CARL TURSE
SOIL TYPE #	3	PROJECT	ROLLIN RIDGE ESTATES
TEST BORING #	TP-13	JOB NO.	170837
DEPTH (FT)	1.5-8	TEST BY	BL

**Sieve Analysis
Grain Size Distribution**

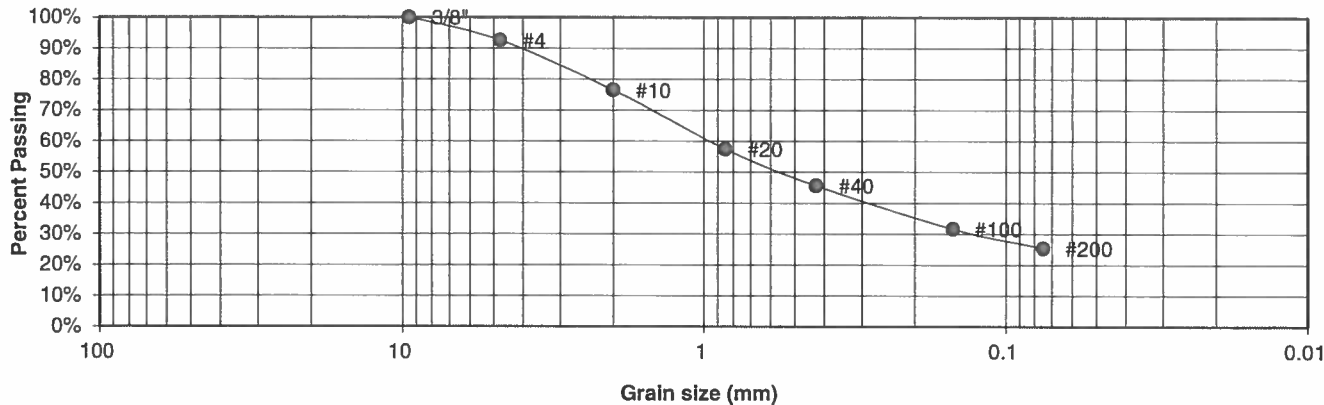

U.S. Sieve #	Percent Finer
3"	
1 1/2"	
3/4"	
1/2"	
3/8"	100.0%
4	92.6%
10	76.5%
20	57.5%
40	45.6%
100	31.7%
200	25.4%

Atterberg Limits
 Plastic Limit
 Liquid Limit
 Plastic Index

Swell
 Moisture at start
 Moisture at finish
 Moisture increase
 Initial dry density (pcf)
 Swell (psf)



**ENTECH
ENGINEERING, INC.**
 505 ELKTON DRIVE
 COLORADO SPRINGS, COLORADO 80907

**LABORATORY TEST
RESULTS**

DRAWN:	DATE:	CHECKED: LLL	DATE: 10/25/17
---------------	--------------	------------------------	--------------------------

JOB NO.:
170837

FIG NO.:
C-19

APPENDIX D: Soil Survey Descriptions

El Paso County Area, Colorado

21—Cruckton sandy loam, 1 to 9 percent slopes

Map Unit Setting

National map unit symbol: 367s
Elevation: 7,200 to 7,600 feet
Mean annual precipitation: 16 to 18 inches
Mean annual air temperature: 42 to 46 degrees F
Frost-free period: 110 to 120 days
Farmland classification: Not prime farmland

Map Unit Composition

Cruckton and similar soils: 85 percent
Estimates are based on observations, descriptions, and transects of the mapunit.

Description of Cruckton

Setting

Landform: Flats, hills
Landform position (three-dimensional): Side slope, talf
Down-slope shape: Linear
Across-slope shape: Linear
Parent material: Alluvium derived from arkose

Typical profile

A - 0 to 11 inches: sandy loam
Bt - 11 to 28 inches: sandy loam
C - 28 to 60 inches: loamy coarse sand

Properties and qualities

Slope: 1 to 9 percent
Depth to restrictive feature: More than 80 inches
Natural drainage class: Well drained
Runoff class: Medium
Capacity of the most limiting layer to transmit water (Ksat):
Moderately high to high (0.60 to 2.00 in/hr)
Depth to water table: More than 80 inches
Frequency of flooding: None
Frequency of ponding: None
Available water storage in profile: Low (about 5.9 inches)

Interpretive groups

Land capability classification (irrigated): None specified
Land capability classification (nonirrigated): 4e
Hydrologic Soil Group: B
Ecological site: Sandy Divide (R049BY216CO)
Hydric soil rating: No

Minor Components

Other soils

Percent of map unit:

Hydric soil rating: No

Data Source Information

Soil Survey Area: El Paso County Area, Colorado

Survey Area Data: Version 14, Sep 23, 2016

El Paso County Area, Colorado

28—Ellicott loamy coarse sand, 0 to 5 percent slopes

Map Unit Setting

National map unit symbol: 3680
Elevation: 5,500 to 6,500 feet
Mean annual precipitation: 13 to 15 inches
Mean annual air temperature: 47 to 50 degrees F
Frost-free period: 125 to 145 days
Farmland classification: Not prime farmland

Map Unit Composition

Ellicott and similar soils: 85 percent
Estimates are based on observations, descriptions, and transects of the mapunit.

Description of Ellicott

Setting

Landform: Flood plains, stream terraces
Landform position (three-dimensional): Tread
Down-slope shape: Linear
Across-slope shape: Linear
Parent material: Sandy alluvium

Typical profile

A - 0 to 4 inches: loamy coarse sand
C - 4 to 60 inches: stratified coarse sand to sandy loam

Properties and qualities

Slope: 0 to 5 percent
Depth to restrictive feature: More than 80 inches
Natural drainage class: Somewhat excessively drained
Runoff class: Very low
Capacity of the most limiting layer to transmit water (Ksat): High to very high (5.95 to 19.98 in/hr)
Depth to water table: More than 80 inches
Frequency of flooding: Frequent
Frequency of ponding: None
Available water storage in profile: Low (about 4.1 inches)

Interpretive groups

Land capability classification (irrigated): None specified
Land capability classification (nonirrigated): 7w
Hydrologic Soil Group: A
Ecological site: Sandy Bottomland LRU's A & B (R069XY031CO)
Other vegetative classification: SANDY BOTTOMLAND (069AY031CO)
Hydric soil rating: No

Minor Components

Fluvaquentic haplaquoll
Percent of map unit:
Landform: Swales
Hydric soil rating: Yes

Other soils
Percent of map unit:
Hydric soil rating: No

Pleasant
Percent of map unit:
Landform: Depressions
Hydric soil rating: Yes

Data Source Information

Soil Survey Area: El Paso County Area, Colorado
Survey Area Data: Version 14, Sep 23, 2016

El Paso County Area, Colorado

41—Kettle gravelly loamy sand, 8 to 40 percent slopes

Map Unit Setting

National map unit symbol: 368h
Elevation: 7,000 to 7,700 feet
Farmland classification: Not prime farmland

Map Unit Composition

Kettle and similar soils: 85 percent
Estimates are based on observations, descriptions, and transects of the mapunit.

Description of Kettle

Setting

Landform: Hills
Landform position (three-dimensional): Side slope
Down-slope shape: Linear
Across-slope shape: Linear
Parent material: Sandy alluvium derived from arkose

Typical profile

E - 0 to 16 inches: gravelly loamy sand
Bt - 16 to 40 inches: gravelly sandy loam
C - 40 to 60 inches: extremely gravelly loamy sand

Properties and qualities

Slope: 8 to 40 percent
Depth to restrictive feature: More than 80 inches
Natural drainage class: Somewhat excessively drained
Runoff class: Medium
Capacity of the most limiting layer to transmit water (Ksat): High
(2.00 to 6.00 in/hr)
Depth to water table: More than 80 inches
Frequency of flooding: None
Frequency of ponding: None
Available water storage in profile: Low (about 3.4 inches)

Interpretive groups

Land capability classification (irrigated): None specified
Land capability classification (nonirrigated): 7e
Hydrologic Soil Group: B
Hydric soil rating: No

Minor Components

Other soils

Percent of map unit:
Hydric soil rating: No

Map Unit Description: Kettle gravelly loamy sand, 8 to 40 percent slopes—El Paso County Area, Colorado

Pleasant

Percent of map unit:

Landform: Depressions

Hydric soil rating: Yes

Data Source Information

Soil Survey Area: El Paso County Area, Colorado

Survey Area Data: Version 14, Sep 23, 2016



El Paso County Area, Colorado

68—Peyton-Pring complex, 3 to 8 percent slopes

Map Unit Setting

National map unit symbol: 369f

Elevation: 6,800 to 7,600 feet

Farmland classification: Not prime farmland

Map Unit Composition

Peyton and similar soils: 40 percent

Pring and similar soils: 30 percent

Estimates are based on observations, descriptions, and transects of the mapunit.

Description of Peyton

Setting

Landform: Hills

Landform position (three-dimensional): Side slope

Down-slope shape: Linear

Across-slope shape: Linear

Parent material: Arkosic alluvium derived from sedimentary rock and/or arkosic residuum weathered from sedimentary rock

Typical profile

A - 0 to 12 inches: sandy loam

Bt - 12 to 25 inches: sandy clay loam

BC - 25 to 35 inches: sandy loam

C - 35 to 60 inches: sandy loam

Properties and qualities

Slope: 3 to 5 percent

Depth to restrictive feature: More than 80 inches

Natural drainage class: Well drained

Runoff class: Low

Capacity of the most limiting layer to transmit water (Ksat):

Moderately high (0.20 to 0.60 in/hr)

Depth to water table: More than 80 inches

Frequency of flooding: None

Frequency of ponding: None

Available water storage in profile: Moderate (about 7.3 inches)

Interpretive groups

Land capability classification (irrigated): None specified

Land capability classification (nonirrigated): 4c

Hydrologic Soil Group: B

Ecological site: Sandy Divide (R049BY216CO)

Hydric soil rating: No

Description of Pring

Setting

Landform: Hills
Landform position (three-dimensional): Side slope
Down-slope shape: Linear
Across-slope shape: Linear
Parent material: Arkosic alluvium derived from sedimentary rock

Typical profile

A - 0 to 14 inches: coarse sandy loam
C - 14 to 60 inches: gravelly sandy loam

Properties and qualities

Slope: 3 to 8 percent
Depth to restrictive feature: More than 80 inches
Natural drainage class: Well drained
Runoff class: Low
Capacity of the most limiting layer to transmit water (Ksat): High
(2.00 to 6.00 in/hr)
Depth to water table: More than 80 inches
Frequency of flooding: None
Frequency of ponding: None
Available water storage in profile: Low (about 6.0 inches)

Interpretive groups

Land capability classification (irrigated): None specified
Land capability classification (nonirrigated): 3e
Hydrologic Soil Group: B
Ecological site: Loamy Park (R048AY222CO)
Hydric soil rating: No

Minor Components

Other soils

Percent of map unit:
Hydric soil rating: No

Pleasant

Percent of map unit:
Landform: Depressions
Hydric soil rating: Yes

Data Source Information

Soil Survey Area: El Paso County Area, Colorado
Survey Area Data: Version 14, Sep 23, 2016

APPENDIX E: Percolation Test Results

Client: Carl Turse
Test Location: Rollin Ridge Estates

Job Number: 170837

PERCOLATION HOLES

Date Holes Prepared: 7/10/2017

Date Hole Completed: 7/11/2017

PH-1

Hole No. 1

Depth: 34"

Hole No. 2

Depth: 36"

Hole No. 3

Depth: 33"

Hole No. 1			Hole No. 2			Hole No. 3		
Trial	Time (min.)	Water Level Change (in.)	Trial	Time (min.)	Water Level Change (in.)	Trial	Time (min.)	Water Level Change (in.)
1	10	1/8	1	10	1/8	1	10	1/4
2	10	1/4	2	10	1/8	2	10	1/4
3	10	1/8	3	10	1/8	3	10	1/4

Perc Rate (min./in.): 80

Perc Rate (min./in.): 80

Perc Rate (min./in.): 40

Average Perc Rate (min./in.): 67

PROFILE HOLE

Date Profile Hole Completed: 7/10/2017

Depth 0-10' Visual Classification Clay, sandy, tan

Remarks

No Bedrock
No Groundwater

10 Blows / ft. @ 2'
12 Blows / ft. @ 4'
15 Blows / ft. @ 9'

LTAR = 0.30 gallons per square foot per day.

Remarks:

Observer: Stu Wood

By:



ENTECH
ENGINEERING, INC.

505 ELKTON DRIVE
COLORADO SPRINGS, COLORADO 80907

PERCOLATION TEST RESULTS

DRAWN:

DATE:

CHECKED:
LLL

DATE:
7/19/17

JOB NO.:

170837

FIG NO.:

E-1

Client: Carl Turse
Test Location: Rollin Ridge Estates

Job Number: 170837

PERCOLATION HOLES

Date Holes Prepared: 7/10/2017

Date Hole Completed: 7/11/2017

PH-2

Hole No. 1

Depth: 46"

Hole No. 2

Depth: 42"

Hole No. 3

Depth: 40"

Hole No. 1			Hole No. 2			Hole No. 3		
Trial	Time (min.)	Water Level Change (in.)	Trial	Time (min.)	Water Level Change (in.)	Trial	Time (min.)	Water Level Change (in.)
1	10	1/16	1	10	3/4	1	10	1/2
2	10	1/8	2	10	1/2	2	10	3/8
3	10	1/16	3	10	1/4	3	10	3/8

Perc Rate (min./in.): 160

Perc Rate (min./in.): 40

Perc Rate (min./in.): 27

Average Perc Rate (min./in.) 76

PROFILE HOLE

Date Profile Hole Completed: 7/10/2017

Depth	Visual Classification	Remarks
0-3'	Clay, sandy, tan	
3-12'	Sand, clayey, fine to coarse grained, tan	Sandstone Bedrock at 12'
12-20'	Sandstone, slightly silty, fine to coarse grained, tan	No Groundwater

Blows / ft. @ 2'
Blows / ft. @ 4'
Blows / ft. @ 9'

LTAR = 0.20 gallons per square foot per day.

Remarks:

Observer: Stu Wood

By:



ENTECH
ENGINEERING, INC.

505 ELKTON DRIVE
COLORADO SPRINGS, COLORADO 80907

PERCOLATION TEST RESULTS

DRAWN:

DATE:

CHECKED:
LLL

DATE:
7/19/17

JOB NO.:

170837

FIG NO.:

E-2

**APPENDIX F: El Paso County Health Department
Septic Records**

EL PASO COUNTY
DEPARTMENT OF HEALTH AND ENVIRONMENT
301 S Union Blvd, Colorado Springs, Colorado 719-575-8636

INDIVIDUAL SEWAGE DISPOSAL SYSTEM PERMIT

OWNER NAME: KAY T COOPER PERMIT NUMBER: ON0007076
ADDRESS: 3285 HODGEN ROAD DATE PERMITTED: 3/30/2006
CITY, STATE, ZIP: COLORADO SPRINGS CO 80921 PHONE NUMBER: 7194953152
INSTALLED BY:

This permit is issued in accordance with 25-10-107 Colorado Revised Statutes. PERMIT EXPIRES upon completion-installation of sewage-disposal system or at the end of twelve (12) months from date of issue- whichever occurs first-(unless work is in progress). If both a building and an ISDS permit are issued for the same property and construction has not commenced prior to the expiration date of the building permit, the ISDS permit shall expire at the same time as the building permit. This permit is revokable if all stated requirements are not met.

Sewage disposal system to be installed by an El Paso County Licensed System Contractor or the property owner.

THIS PERMIT DOES NOT DENOTE APPROVAL OF ZONING AND ACREAGE REQUIREMENTS.

Rosemary C. Baker-Martin

DIRECTOR, EL PASO COUNTY DEPARTMENT OF HEALTH AND ENVIRONMENT

PERMIT EXPIRATION DATE :
Expires twelve months from date of issue

Janet Christensen 578-3141
ENVIRONMENTALIST / PHONE NUMBER*

* NOTE: FOR INSPECTIONS CALL 575-8699 BEFORE 8:30 A.M. OF THE DAY TO BE INSPECTED.
(WEEKENDS & HOLIDAYS EXCLUDED)

LEAVE THE ENTIRE SEWAGE DISPOSAL SYSTEM UNCOVERED FOR FINAL INSPECTION.

WATER SOURCE: WELL

MINIMUM SEPTIC TANK SIZE: Existing 1250 GALLONS

MINIMUM ABSORPTION AREA REQUIRED N/A SQ FT

PLANNING DEPARTMENT



ENUMERATION



FLOOD PLAIN



WASTEWATER



COMMENTS:

OWNER MAY ADD DESIRED SQUARE FOOTAGE DIRECTLY TO THE EXISTING LEACH FIELD.

DEPTH OF SYSTEM SHALL NOT EXCEED 4 FEET BELOW NATIVE GROUND SURFACE DUE TO BEDROCK AT 8 FEET. (SOIL PERCOLATION TEST OF FEB 1993).

IF A DIVERTER VALVE IS INSTALLED - A MINIMUM OF 917 SQUARE FEET ABSORPTION AREA MUST BE INSTALLED. IF OWNER DESIRES TO BRING EXISTING ABSORPTION AREA SQUARE FOOTAGE TO CURRENT REGULATION SIZE, AN ADDITIONAL 317 SQUARE FEET PLUS CURRENT 600 SQUARE FEET = 917 SQUARE FEET.

The Health Office shall assume no responsibility in case of failure or inadequacy of a sewage-disposal system, beyond consulting in good faith with the property owner or representative. Free access to the property shall be authorized at reasonable time for the purpose of making such inspections as are necessary to determine compliance with requirements of this law.

FOR ADMINISTRATIVE USE ONLY

Permit Ready: 3-30-06 Called _____ Mailed _____

Final Inspection Requested: BY: Jackie Downbeath Date Called In: 4/17/06 '6:24

Phone # 495-3660

Septic Site will be ready: now

Inspector _____

Record I.D. 7076

EL PASO COUNTY DEPARTMENT OF HEALTH & ENVIRONMENT

301 South Union Boulevard • Colorado Springs, CO • 80910-3123 • (719) 575-8635 • Fax: (719) 578-3188

***ALL PAYMENTS ARE DUE AT TIME OF SUBMITTAL IN CASH OR CHECK**

APPLICATION FOR AN ON-SITE WASTEWATER TREATMENT SYSTEM PERMIT

NEW CONSTRUCTION MINOR REPAIR MAJOR REPAIR/ADD

Owner Kay T Cooper / Michael D Stowell Daytime Phone 719-344-495-3152

Address of Property 3285 Hodgen Road City & Zip C/S CO 80921

Legal Description E2 NE4 NW4 EX N 30 FT SEC 27-11-66

Owner's MAILING Address same City, State & Zip _____

Lot Size 2162 Tax Schedule # 61270-00-055

Type of Building: Frame Modular Mobile Commercial Manufactured Other _____

Water Supply: Well or Spring Cistern Public Inside City Limits: No Yes-City _____

MAIL PERMIT OR PICK UP PERMIT THERE IS AN ADDITIONAL RESIDENCE ON THIS PROPERTY

MAXIMUM POTENTIAL NUMBER OF BEDROOMS 3

Percolation Test Attached Y Basement Y Garbage Disposal Y N Clothes Washer Y N

I have supplied a plot plan as described on the back of this form. I acknowledge the completeness of the application is conditional upon such further mandatory and additional tests and reports as may be required by the Department to be made and furnished by an applicant for purposes of evaluating the application, and issuance of the permit is subject to such terms and conditions as deemed necessary to ensure compliance with rules and regulations adopted pursuant to C.R.S. 25-10-107 et. seq. I hereby certify all represented to be true and correct to the best of my knowledge and belief, and are designed to be relied on by the El Paso County Department of Health and Environment in evaluating the same for purposes of issuing the permit applied for herein. I further understand any falsification or misrepresentation may result in the denial of the application or revocation of any permit granted based upon said application and in legal action for perjury as provided by law.

OWNER'S SIGNATURE see attached application Date 3/29/06

You will be notified by telephone when your permit is ready for pick up. Please allow a minimum of 10 days for new septic.

DEPARTMENT OF HEALTH USE ONLY

Existing 1250 Minimum Tank Capacity N/A Minimum Absorption Area 30 March 2006 Date of Site Inspection

REMARKS: Owner may add desired square footage directly to the existing leach field. Depth of system shall not exceed 4ft below native ground surface due to bedrock at 8ft. (Soil percolation test of Feb. 1993). If a diverter valve is installed - a minimum of 917 ft² absorption area must be installed. If owner desires to bring existing absorption area square footage to current regulation size, an additional 317 ft² + current 600 ft² = 917 ft².

EHS INSPECTOR Janet Doustman DATE 03-30-06 APPROVED DENIED

FEES AS OF 02/22/2006:

NEW CONSTRUCTION \$350.00 + Planning Department Surcharge of \$118.00. 468.00
MAJOR REPAIR/ADDITION ~~\$430.00~~
MINOR REPAIR/ADDITION \$179.00

DATE TO PLANNING / WASTEWATER: _____

DATE TO FLOODPLAIN/ENUMERATIONS _____

PLEASE COMPLETE THE BACK OF THIS FORM

- 1) We require an original of your **PERCOLATION (PERC) TEST** with an original professional engineer's (PE) stamp and signature as well as a plot of the percolation test hole locations with measurements from a fixed reference point.
- 2) **PROPERTY ADDRESS OR LOT NUMBER MUST BE POSTED AND CLEARLY VISIBLE FROM ROAD. PERC HOLES MUST BE CLEARLY MARKED OR AN ADDITIONAL CHARGE FOR A RETURN TRIP TO THE SITE MAY BE ASSESSED.**

3) A **PLOT PLAN** must be drawn (not to scale) on an 8 1/2 x 11 sheet of paper. The plot plan must include:

- | | | |
|------------------------|---|---|
| 1) a north bearing | 4) all buildings (proposed or existing) | 7) driveway (proposed or existing and name of adjoining street) |
| 2) property lines | 5) proposed septic system site | |
| 3) property dimensions | 6) alternate septic system site | |

4) Initial any of the following features that apply to your property and **INCLUDE** them on your **PLOT PLAN**.

- | | | |
|----------------------------------|--|--|
| <input type="checkbox"/> Well(s) | <input type="checkbox"/> Adjacent property well(s) | <input type="checkbox"/> Subsoil drain |
| <input type="checkbox"/> Cistern | <input type="checkbox"/> Water line | |

5) Initial any of the following that are within 100 feet of your proposed septic system and **INCLUDE** on your **PLOT PLAN**.

- | | |
|--|---|
| <input type="checkbox"/> Spring(s) | <input type="checkbox"/> Lake(s) |
| <input type="checkbox"/> Pond(s) | <input type="checkbox"/> Stream(s) |
| <input type="checkbox"/> Dry Gulch(es) | <input type="checkbox"/> Natural drainage course(s) |

6) **GIVE COMPLETE DIRECTIONS TO THE PROPERTY FROM A MAIN HIGHWAY**

Hwy 83 North

West on Hodgen

about 1/4 mile driveway on LEFT side.

* please call before going out *

Cell-210-1971

Percolation rate 18 min/inch bedrock @ 8ft
 9.17 ft² = current reg. cr. 36 chambers trench or 39 in bed
 Existing 13' Bio. Filters - credited for 600 ft²