



INNOVATIVE DESIGN. CLASSIC RESULTS.

**WATER RESOURCES REPORT
FOR
RISING MOON FILING NO. 1 & 2**

MARCH 2025

Prepared By:

**Classic Consulting Engineers & Surveyors LLC
619 N. Cascade Ave. Suite 200
Colorado Springs, CO 80903**

Prepared for:

**Colorado Centre Metropolitan District
4770 Horizonview Dr.
Colorado Springs, CO 80925**

Job No. 2506.03



TABLE OF CONTENTS

1.0	INTRODUCTION AND EXECUTIVE SUMMARY	Page 1
2.0	PROJECTED LAND USES	Page 1
2.1	Projected Land Uses	Page 1
2.2	Water Demands for the Subject Property	Page 1
2.3	Service	Page 2
3.0	DISTRICT WATER NEEDS AND PROJECTED DEMANDS	Page 3
3.1	Actual Water Demand Summary	Page 3
3.2	Unit Water User Characteristics	Page 4
3.3	Current Demands versus Supply	Page 4
4.0	WATER RIGHTS AND SUPPLY	Page 5
4.1	District Water Rights	Page 5
4.2	Adequacy of Water Rights	Page 5
4.3	Description of Current Water Rights	Page 6
5.0	WATER SYSTEM FACILITIES AND PHYSICAL SUPPLY	Page 6
5.1	Source of Supply	Page 6
5.2	Water Treatment	Page 7
5.3	Water Storage	Page 7
5.4	Distribution, Pumping, and Transmission Lines	Page 7
5.5	Recent and Upcoming System Expansions	Page 7
5.6	Water Quality	Page 8
6.0	EL PASO COUNTY MASTER PLANNING ELEMENTS	Page 9
6.1	County Water Master Plan 2040 and 2060 Projections	Page 9
6.2	Description of Long-Term Planning and Future Sources of Supply	Page 10
7.0	CONCLUSION	Page 10

APPENDICES

- Appendix A – Land Use Exhibit
- Appendix B – Water Supply Information Summary
- Appendix C – Service Commitment Letter
- Appendix D – Supporting Colorado Centre Metropolitan District Spreadsheets
- Appendix E – Necessary Improvements to Provide Service (PUD Preliminary Utility Sheet)
- Appendix F – District Service Map

1.0 INTRODUCTION AND EXECUTIVE SUMMARY

The purpose of this report is to address the specific water needs of the proposed 41 Single Family Residential lot subdivision for Rising Moon Filing No. 1 & 2 located north of Peaceful Meadow Street and west of Shining Star Drive in El Paso County, Colorado. The proposed residential development is being subdivided out of a larger 9.00-acre previously platted Tract (Tract B, Morning Sun, Book 44, Page 179 of the Records of El Paso County) as shown on the Preliminary Plan contained in Appendix A. This project is currently seeking approval of a Preliminary Plan through El Paso County, and this report is a requirement for approval. Please note that this report was based on Entitlement Plan level drawings (Appendix A) and information, and that the final approval project may differ from the information used to generate this report as construction drawings are prepared.

EXECUTIVE SUMMARY: Per the issued March 18, 2025 letter from Colorado Centre Metropolitan District (CCMD), the District has adequate water supply to meet the needs of the proposal residential subdivision. Wastewater treatment will also be provided by CCMD as well and is addressed in the Wastewater Disposal Report.

2.0 PROJECTED LAND USES

2.1 Projected Land Uses

The 9.00 acres of land within the subject area (located on El Paso County Parcel – Tax ID # 55031-01-010) is currently vacant. The plan is to subdivide 41 single family residential lots out of this property (average lot size is 5,914 SF). This report and associated commitments pertain to the properties proposed to encompass the entire previously platted tract area. Please refer to the Exhibit in Appendix A.

2.2 Water Demands for the Subject Property

Lots within the subject area have been planned as a typical single family lot residential development. The overall 41 lot residential development will demand typical (unless noted) on lot irrigation demands constants per El Paso County Land Code per Section 8.4.7(B)(7)(d). Projected demands for the 41-lot

residential community are projected to require 10.660 AF/year. Irrigation demand is anticipated to require 5.211 AF/year. Total combined demand is 15.871 AF/year

2.3 Service

The proposed subdivision is located within the Colorado Centre Metropolitan District (CCMD) service area. Therefore, the 41 lots can and will be provided water services by CCMD. (See service commitment letter from CCMD provided in Appendix C, and schematic of district water services boundary map provided in Appendix F). To provide service to the 41 proposed lots, two public water main extensions must be extended into the site from the existing 8" PVC mainline in Peaceful Valley Street. Currently, the 8" PVC main in Peaceful Valley Street supports service to the existing residential area to the south. It is estimated that with connection to this existing 8" system and associated loop through the development, this would be sufficient to provide adequate water service pressure and fire flows for the proposed 41 lots. A secondary water connection in Chia Drive, looping north to Sand Myrtle Drive will allow a redundant looped water main in the development. The developer's engineer will need to work with CCMD's consulting engineer and the jurisdictional fire department (in this case being the Colorado Springs Fire Department) to determine the final alignment and size of the proposed water main and associated water taps to facilitate adequate fire flows and service pressures. A preliminary depiction of the potential water service lines and associated fire hydrants is shown in Appendix E.

Summary of Expected Water Demands & Wastewater Loads

Table 2-1

Rising Moon Filing No. 1 & 2

Estimate of Water Demands & Wastewater Loads

# of Units	Land Use	Water Use per Unit (AF/Unit)	Annual Demand (AF)	Average Daily Flow (ADF) (GPD)
41	Residential	0.260	10.660	9,511
41	Res. Irrig.	0.127	5.211	4,649

3.0 DISTRICT WATER NEEDS AND PROJECTED DEMANDS

3.1 Actual Water Demand Summary

Appendix D reflects the CCMD provided Tabulation of Current and Projected Water Consumption.

3.2 Unit Water User Characteristics

Unit water user characteristics are counted on a Single-Family Equivalent (SFE) basis. As provided by CCMD, the District bases its connection fees and /or taps on the demand volumes required by the State for planning purposes. For residential uses, that number is 0.24 gallons per minute or 345.6 gallons per day, or 126,144 gallons per year, or 0.3871 ac-ft per year. Which for 41 single family units totals 15,871 ac-ft per year total. Even though this community is comprised of small single family residential homes, the typical single family consumption rate is used.

It should be noted that water saving fixtures have increased in installation since 2014 across the United States. The above stated demand numbers should be considered conservative.

3.3 Current Demands versus Supply

Appendix D reflects the CCMD provided Tabulation of Current and Projected Water Consumption.

4.0 WATER RIGHTS AND SUPPLY

4.1 District Water Rights

Colorado Centre Metropolitan District has water rights from several different sources including Janitell Wells, Cuchares Wells and Robinson Ditch rights.

5.0 WATER SYSTEM FACILITIES AND PHYSICAL SUPPLY

5.1 Source of Supply

See Section 4.1 above for description of available water sources.

6.0 EL PASO COUNTY MASTER PLANNING ELEMENTS

6.1 County Water Master Plan 2040 and 2060 Projections

Rising Moon Filing No. 1 & 2 lies within the El Paso County Master Planning area, and is identified as suburban residential. Rising Moon Filing No. 1 & 2 will be served by Colorado Centre Metropolitan District for water services.

7.0 CONCLUSION

Colorado Centre Metropolitan District has adequate water supply to meet the needs of this proposed land use.

REFERENCE:

Provided Colorado Centre Metropolitan District March 18, 2025 letter and supporting calculations.

sm/n drive/250603/reports/water resources report

APPENDIX A

RISING MOON FILING NO. 1 & 2

A REPLAT TRACT B OF MORNING SUN I

EAST 1/2 OF SEC. 3, TOWNSHIP 15S, RANGE 65 WEST, COUNTY OF EL PASO, STATE OF COLORADO

PRELIMINARY PLAN

GENERAL NOTES:

- ALL SIDEWALKS SHOWN ON PRELIMINARY PLAN ARE TO BE 5' CONCRETE UNLESS OTHERWISE SPECIFIED.
- DEVELOPER SHALL ANALYZE THE NEED TO PROVIDE ALL NECESSARY OFFSITE ROAD IMPROVEMENTS, WHICH MAY INCLUDE IMPROVEMENTS IN THE CITY OF COLORADO SPRINGS, TO PROVIDE AN APPROPRIATE LEVEL OF SERVICE TO THIS DEVELOPMENT. IF OFFSITE ROAD IMPROVEMENTS ARE NECESSARY, THEY WILL BE SPECIFICALLY OUTLINED PER A SUBDIVISION IMPROVEMENTS AGREEMENT OR DEVELOPMENT AGREEMENT BETWEEN DEVELOPER AND EL PASO COUNTY.
- ALL STREETS SHALL BE NAMED AND CONSTRUCTED TO EL PASO COUNTY STANDARDS AND ANY APPROVED DEVIATION. UPON ACCEPTANCE EL PASO COUNTY, PUBLIC STREETS SHALL BE MAINTAINED BY THE COUNTY.
- NOTWITHSTANDING ANYTHING DEPICTED IN THIS PLAN IN WORDS OR GRAPHIC REPRESENTATION, ALL DESIGN AND CONSTRUCTION RELATED TO ROADS, STORM DRAINAGE AND EROSION CONTROL SHALL CONFORM TO THE STANDARDS AND REQUIREMENTS OF THE MOST RECENT VERSION OF THE RELEVANT ADOPTED EL PASO COUNTY STANDARDS, INCLUDING THE LAND DEVELOPMENT CODE (LDC), THE ECM, THE DRAINAGE CRITERIA MANUAL (DCM), AND THE DCM VOLUME 2. ANY DEVIATIONS FROM THESE STANDARDS MUST BE SPECIFICALLY REQUESTED AND APPROVED IN WRITING TO BE ACCEPTABLE. THE APPROVAL OF THIS PRELIMINARY PLAN DOES NOT IMPLICITLY ALLOW ANY DEVIATIONS OR WAIVERS THAT HAVE NOT BEEN OTHERWISE APPROVED THROUGH THE DEVIATION APPROVAL PROCESS.
- THE SUBDIVIDER(S) AGREE ON BEHALF OF HIM/HERSELF AND ANY DEVELOPER OR BUILDER SUCCESSORS AND ASSIGNEES THAT SUBDIVIDER AND/OR SAID SUCCESSORS AND ASSIGNS SHALL BE REQUIRED TO PAY TRAFFIC IMPACT FEES IN ACCORDANCE WITH THE EL PASO COUNTY ROAD IMPACT FEE PROGRAM RESOLUTIONS (RESOLUTION NO.19-471), OR ANY AMENDMENTS THERETO, AT OR PRIOR TO THE TIME OF BUILDING PERMIT SUBMITTALS. THE FEE OBLIGATION, IF NOT PAID AT FINAL PLAT RECORDING, SHALL BE DOCUMENTED ON ALL SALES DOCUMENTS AND ON PLAT NOTES TO ENSURE THAT A TITLE SEARCH WOULD FIND THE FEE OBLIGATION BEFORE SALE OF THE PROPERTY.
- THE FOLLOWING UTILITY PROVIDERS WILL SERVE THE RISING MOON FILING NO. 1 PRELIMINARY PLAN AREA INSTALLED BY THE DEVELOPER:
 - PIKES PEAK HABITAT FOR HUMANITY, INC.
 - COLORADO CENTRE METROPOLITAN DISTRICT
 - COLORADO CENTRE METROPOLITAN DISTRICT
 - COLORADO SPRINGS UTILITIES GAS
 - MOUNTAIN VIEW ELECTRIC ASSOCIATION, INC.
- THE FOLLOWING REPORTS HAVE BEEN SUBMITTED IN ASSOCIATION WITH THE PRELIMINARY PLAN FOR THIS SUBDIVISION AND ARE ON FILE AT THE COUNTY PLANNING AND COMMUNITY DEVELOPMENT DEPARTMENT: TRANSPORTATION IMPACT STUDY; DRAINAGE REPORT; WATER RESOURCES REPORT; WASTEWATER DISPOSAL REPORT; GEOLOGY AND SOILS REPORT; FIRE PROTECTION REPORT.
- DEVELOPER SHALL COMPLY WITH FEDERAL AND STATE LAWS, REGULATION, ORDINANCES, REVIEW AND PERMIT REQUIREMENTS, AND OTHER AGENCY REQUIREMENTS, IF ANY, OF APPLICABLE AGENCIES INCLUDING, BUT NOT LIMITED TO, THE COLORADO PARKS AND WILDLIFE, COLORADO DEPARTMENT OF TRANSPORTATION, U.S. ARMY CORPS OF ENGINEERS AND THE U.S. FISH AND WILDLIFE SERVICE REGARDING THE ENDANGERED SPECIES ACT, PARTICULARLY AS IT RELATES TO THE LISTED SPECIES (E.G., PREBLE'S MEADOW JUMPING MOUSE).
- THE PARTIES RESPONSIBLE FOR THIS PLAN HAVE FAMILIARIZED THEMSELVES WITH ALL CURRENT ACCESSIBILITY CRITERIA AND SPECIFICATIONS AND THE PROPOSED PLAN REFLECTS ALL SITE ELEMENTS REQUIRED BY THE APPLICABLE ADA DESIGN STANDARDS AND GUIDELINES AS PUBLISHED BY THE UNITED STATES DEPARTMENT OF JUSTICE. APPROVAL OF THIS PLAN BY EL PASO COUNTY DOES NOT ASSURE COMPLIANCE WITH THE ADA OR ANY REGULATIONS OR GUIDELINES ENACTED OR PROMULGATED UNDER OR WITH RESPECT TO SUCH LAWS.
- UNLESS OTHERWISE INDICATED, ALL LOTS HAVE THE FOLLOWING EASEMENTS, 7' REAR PUBLIC UTILITY AND DRAINAGE EASEMENT, 5' SIDE PUBLIC EASEMENTS, 5' FRONT PUBLIC UTILITY AND PUBLIC IMPROVEMENT EASEMENT, AND ADDITIONAL EXCLUSIVE 10' FRONT PUBLIC UTILITY EASEMENT. THE SOLE RESPONSIBILITY FOR MAINTENANCE OF THESE EASEMENTS IS HEREBY VESTED WITH THE INDIVIDUAL PROPERTY OWNERS.
- THERE SHALL BE NO DIRECT LOT ACCESS TO PEACEFUL MEADOW STREET FOR ANY RESIDENTIAL LOTS.
- ANY LANDSCAPING IN THE PUBLIC RIGHT-OF-WAY WILL REQUIRE A LICENSE AGREEMENT WITH THE HOMEOWNERS ASSOCIATION AT TIME OF FINAL PLAT.
- SOIL AND GEOLOGY CONDITIONS:
 - GEOLOGIC HAZARD NOTE-PRELIMINARY PLAN: THE FOLLOWING LOTS HAVE BEEN FOUND TO BE IMPACTED BY GEOLOGIC HAZARDS. MITIGATION MEASURES AND A MAP OF THE HAZARD AREA CAN BE FOUND IN THE REPORT "SOILS AND GEOLOGY STUDY RISING MOON - HABITAT FOR HUMANITY" BY ENTECH ENGINEERING INC. DATED MARCH 27, 2024 IN FILE (SP243) AVAILABLE AT THE EL PASO COUNTY PLANNING AND COMMUNITY DEVELOPMENT DEPARTMENT:
 - EXPANDABLE SOILS: (ALL LOTS)
 - LOOSE/COLLAPSIBLE SOILS: (ALL LOTS)

IN AREAS OF HIGH GROUNDWATER: DUE TO THE POTENTIAL FOR GROUNDWATER IN THE AREA, ALL FOUNDATIONS SHALL INCORPORATE AN UNDERGROUND DRAINAGE SYSTEM FOR ANY HOMES WITH USABLE BELOW GRADE SPACE.

GEOLOGIC HAZARD NOTE: THE GEOLOGIC HAZARD IDENTIFIED IN THE ENTECH REPORT INCLUDE THE POTENTIAL FOR RADON. A MAP OF THE AREA CAN BE FOUND IN THE REPORT "SOILS AND GEOLOGY STUDY RISING MOON - HABITAT FOR HUMANITY" PREPARED BY ENTECH ENGINEERING, INC., DATED MARCH 27, 2024 AVAILABLE AT THE EL PASO COUNTY PLANNING AND COMMUNITY DEVELOPMENT DEPARTMENT.

INVESTIGATION ON EACH LOT IS RECOMMENDED PRIOR TO CONSTRUCTION PER THE ENTECH REPORT. RECOMMENDATIONS FROM THE GEOTECHNICAL ENGINEER SHOULD BE CAREFULLY FOLLOWED ESPECIALLY REGARDING SITE GRADING FOR SURFACE RUNOFF AND PERIMETER DRAINS WHERE SHALLOW GROUNDWATER IS ENCOUNTERED OR EXPECTED. SITE SPECIFIC SOIL AND FOUNDATION INVESTIGATIONS SHOULD SPECIFICALLY EVALUATE FOR THE PRESENCE OF GROUNDWATER AND POTENTIALLY EXPANSIVE AND/OR COLLAPSIBLE SOILS AND FILL PRIOR TO FOUNDATION DESIGN. ALL RECOMMENDATIONS IN THE ENTECH REPORT SHOULD BE ADHERED TO.

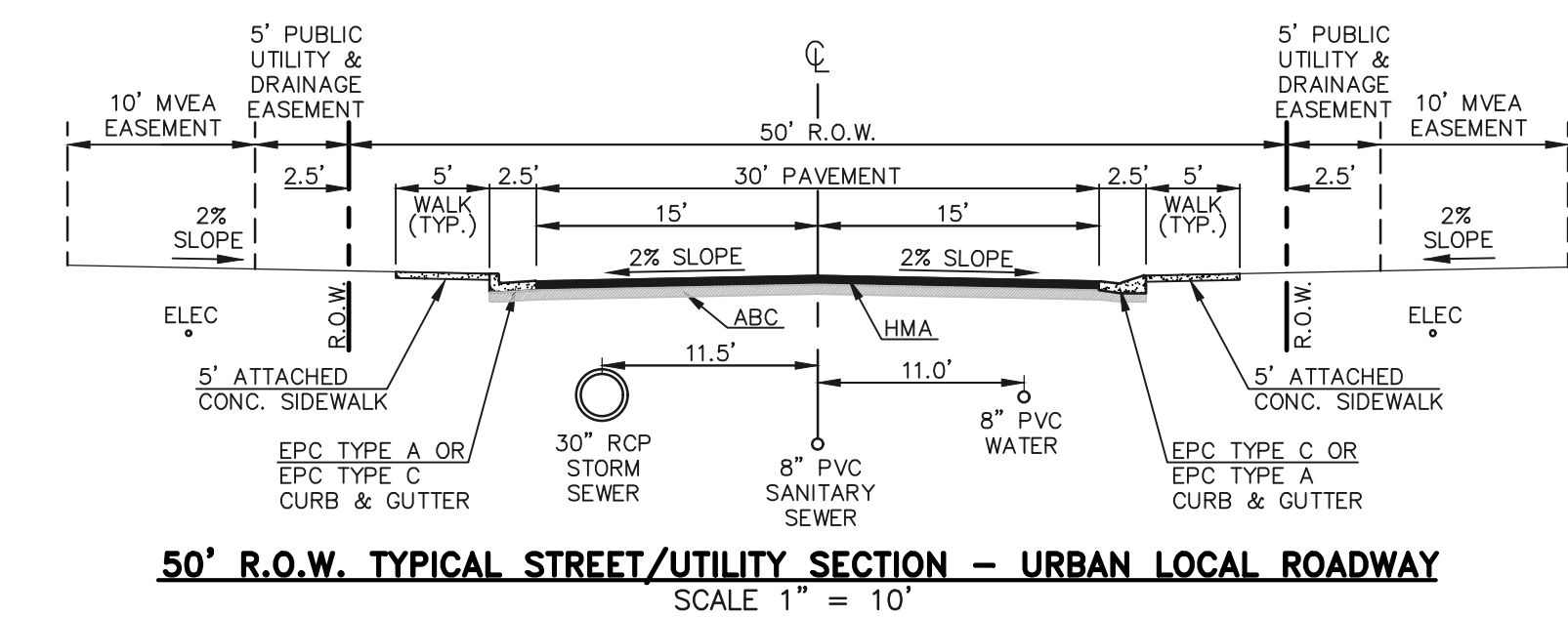

NOTE: THIS COMMUNITY WILL NOT REQUIRE GAS FACILITIES (HOMES ARE ALL ELECTRIC)

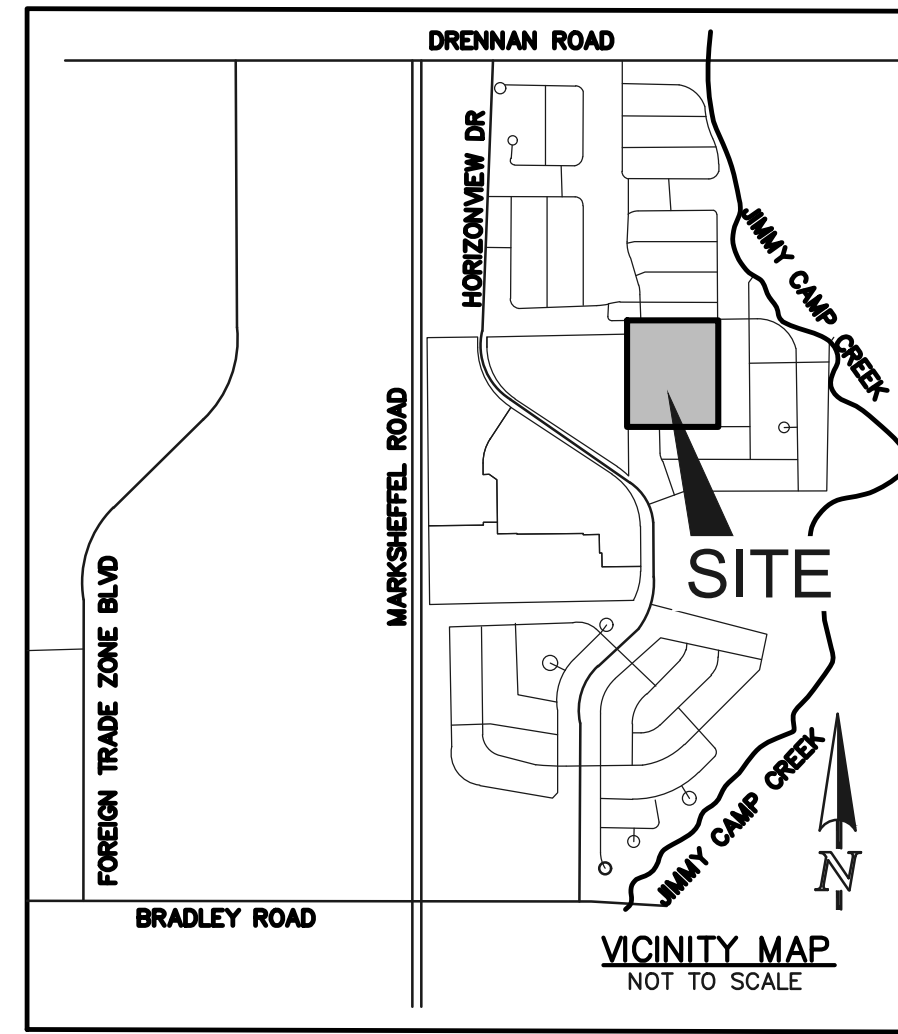

SITE DATA

TAX ID NUMBER:	5503101010
TOTAL AREA:	9.00 ACRES
DEVELOPMENT SCHEDULE:	SPRING 2025
CURRENT ZONING:	RS-5000 CAD-O
CURRENT USE:	VACANT
PROPOSED USE:	SINGLE FAMILY RESIDENTIAL SUBURBAN
PROPOSED GROSS DENSITY:	4.5 DU/AC (41 LOTS/9.00 AC)
PROPOSED NET DENSITY:	7.0 DU/AC (41 LOTS/5.80 AC)
LANDSCAPE SETBACKS:	10' ALONG PEACEFUL MEADOW STREET

TRACT TABLE

TRACT	AREA (SF)	AREA (AC.)	USE	OWNERSHIP/MAINTENANCE
A FIL.1	46,894	1.08	PARK, LANDSCAPE, OPEN SPACE, DRAINAGE, DETENTION, UTILITIES	HOMEOWNERS ASSOCIATION
B FIL.1	1,763	0.04	DRAINAGE, LANDSCAPE, UTILITIES	HOMEOWNERS ASSOCIATION
A FIL.2	824	0.02	DRAINAGE, LANDSCAPE, UTILITIES	HOMEOWNERS ASSOCIATION
TOTAL TRACT AREA = 1.14 ACRES				

ZONE DIMENSIONAL STANDARDS

ZONE	MIN. LOT SIZE	MAX. BUILDING HEIGHT	MAX. LOT COVERAGE	MIN. LOT WIDTH AT FRONT SETBACK LINE	FRONT BUILDING SETBACK	SIDE BUILDING SETBACK	REAR BUILDING SETBACK
RS-5000/CAD-O	5,000 SF	30'	40%/45%	50'	25'	5'	25'

LAND USE DATA TABLE

LAND USE	ACRES	% OF LAND
SINGLE FAMILY	5.80	64.4%
ROAD ROW	2.07	23.0%
DRAINAGE, LANDSCAPE, UTILITIES	0.05	0.6%
PARK, LANDSCAPE, UTILITIES, OPEN SPACE, DETENTION	1.08	12.0%
TOTAL	9.00	100%

PROJECT TEAM

OWNER: PIKES PEAK HABITAT FOR HUMANITY INC.
2802 N. PROSPECT ST.
COLORADO SPRINGS, CO 80907
(719)661-5527
BINGELS@ORWOOD.DEV

APPLICANT/CIVIL CONSULTANT: CLASSIC CONSULTING ENGINEERS & SURVEYORS, LLC
619 N. CASCADE AVENUE, SUITE 200
COLORADO SPRINGS, CO 80903
MR. KYLE CAMPBELL, P.E.
(719) 785-0790

SHEET INDEX:

TITLE SHEET	SHEET 1 OF 4
LEGAL BOUNDARY & ADJACENT PROPERTY OWNERS EXHIBIT	SHEET 2 OF 4
PRELIMINARY SITE PLAN	SHEET 3 OF 4
PRELIMINARY GRADING & UTILITY PLAN	SHEET 4 OF 4

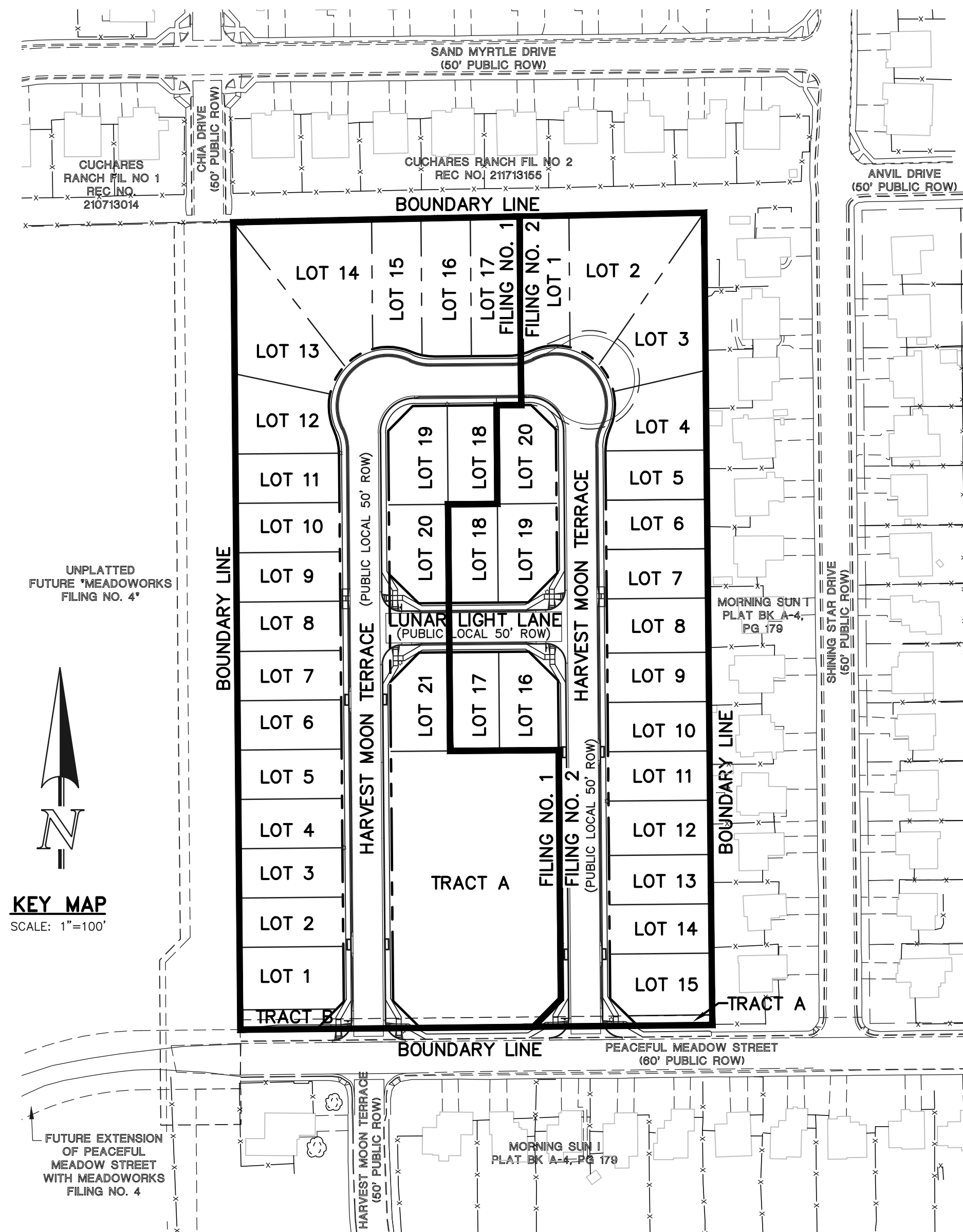

EL PASO COUNTY FILE NO.: SP243

	RISING MOON FILING NO. 1 & 2 PRELIMINARY PLAN TITLE SHEET			
	DESIGNED BY	MES		SCALE
DRAWN BY	KES	(H) 1" = 100'	SHEET	1 OF 4
CHECKED BY	(V) 1" = N/A	JOB NO.	2506.03	

619 N. Cascade Avenue, Suite 200 (719)785-0790 Colorado Springs, Colorado 80903

RISING MOON FILING NO. 1 & 2

REPLAT TRACT B OF MORNING SUN I
EAST 1/2 OF SEC. 3, TOWNSHIP 15S, RANGE 65 WEST, COUNTY OF EL PASO, STATE OF COLORADO

PRELIMINARY PLAN

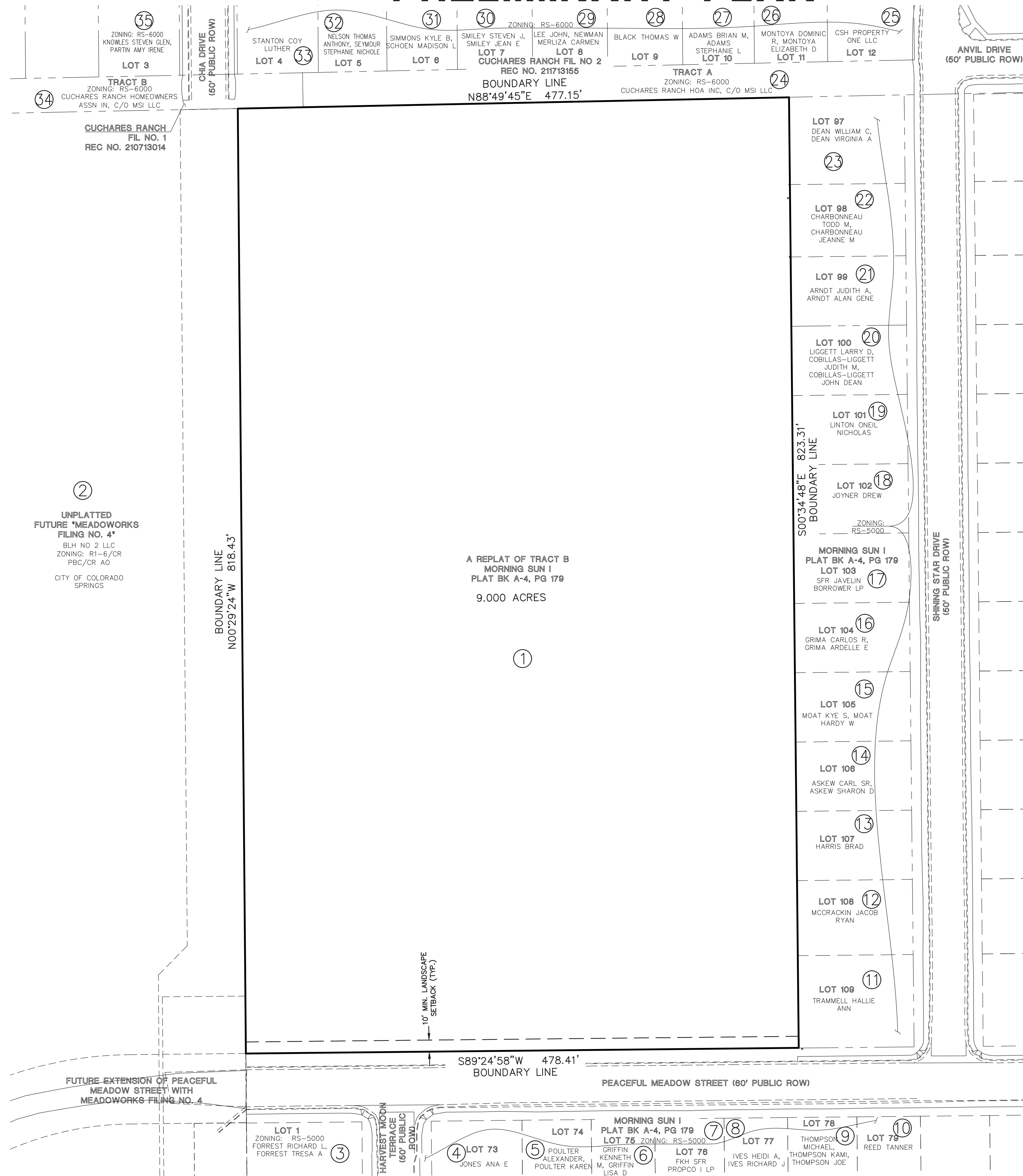

LEGAL DESCRIPTION

LEGAL DESCRIPTION: RISING MOON FILING NO. 1 PRELIMINARY PLAN.

A REPLAT TRACT B OF MORNING SUN I RECORDED IN PLAT BOOK A-4 AT PAGE 179 BEING LOCATED IN THE EAST 1/2 OF SECTION 3, TOWNSHIP 15 SOUTH, RANGE 65 WEST OF THE SIXTH PRINCIPAL MERIDIAN, COUNTY OF EL PASO, STATE OF COLORADO.

CONTAINING A CALCULATED AREA OF 9.000 ACRES.

BASIS OF BEARINGS

ALL BEARINGS ARE RELATIVE TO THE NORTH LINE OF SECTION 3, TOWNSHIP 15 SOUTH, RANGE 65 WEST OF THE 6TH PRINCIPAL MERIDIAN, EL PASO COUNTY, COLORADO, IS ASSUMED TO BEAR S89°53'55"W.

ADJACENT OWNER	NAME	MAILING ADDRESS	CITY, STATE, ZIP CODE
1	PIKES PEAK HABITAT FOR HUMANITY, INC.	2802 N PROSPECT ST	COLORADO SPRINGS CO 80907-6325
2	BLH NO 2 LLC	111 S TEJON ST STE 222	COLORADO SPRINGS CO 80903-2246
3	FORREST RICHARD L	4052 HARVEST MOON TER	COLORADO SPRINGS CO 80925-1110
4	JONES ANA E	9303 PEACEFUL MEADOW ST	COLORADO SPRINGS CO 80925-1120
5	POULTER ALEXANDER	9311 PEACEFUL MEADOW ST	COLORADO SPRINGS CO 80925-1120
6	GRIFFIN KENNETH M	9319 PEACEFUL MEADOW ST	COLORADO SPRINGS CO 80925-1120
7	FKH SFR PROPCO I LP	31 W 27TH ST 4TH FLOOR	NEW YORK NY 10001
8	IVES HEIDI A	9335 PEACEFUL MEADOW ST	COLORADO SPRINGS CO 80925-1120
9	THOMPSON MICHAEL	9343 PEACEFUL MEADOW ST	COLORADO SPRINGS CO 80925-1120
10	REED TANNER	9351 PEACEFUL MEADOW ST	COLORADO SPRINGS CO 80925-1120
11	TRAMMELL HALLIE ANN	4036 SHINING STAR DR	COLORADO SPRINGS CO 80925-1103
12	MCCRACKIN JACOB RYAN	4028 SHINING STAR DR	COLORADO SPRINGS CO 80925
13	HARRIS BRAD	4020 SHINING STAR DR	COLORADO SPRINGS CO 80925-1103
14	ASKEW CARL SR	4012 SHINING STAR DR	COLORADO SPRINGS CO 80925-1103
15	MOAT KYE S	7049 TAFT COURT	COLORADO SPRINGS CO 80911
16	GRIMA CARLOS R	3960 SHINING STAR DR	COLORADO SPRINGS CO 80925-1133
17	SFR JAVELIN BORROWER LP	1717 MAIN ST SUITE 2000	DALLAS TX 75201
18	JOYNER DREW	3944 SHINING STAR DR	COLORADO SPRINGS CO 80925-1133
19	LINTON ONEIL NICHOLAS	3355 CALAVERAS WAY	COLORADO SPRINGS CO 80910-1409
20	LIGGETT LARRY D	3928 SHINING STAR DR	COLORADO SPRINGS CO 80925
21	ARNDT JUDITH A	3920 SHINING STAR DR	COLORADO SPRINGS CO 80925-1101
22	CHARBONNEAU TODD M	3912 SHINING STAR DR	COLORADO SPRINGS CO 80925-1101
23	DEAN WILLIAM C	3904 SHINING STAR DR	COLORADO SPRINGS CO 80925-1101
24	CUCHARS RANCH HOMEOWNERS ASSN INC	11002 BENTON ST	BROOMFIELD CO 80020-3286
25	CSH PROPERTY ONE LLC	1717 MAIN ST STE#2000	DALLAS TX 75201
26	MONTOKA DOMINIC R	9575 SAND MYRTLE DR	COLORADO SPRINGS CO 80925-1113
27	ADAMS BRIAN M	9565 SAND MYRTLE DR	PUEBLO CO 81003
28	BLACK THOMAS W	10445 CHEETAH WINDS	LONE TREE CO 80124
29	LEE JOHN	9545 SAND MYRTLE DR	COLORADO SPRINGS CO 80925-1113
30	SMILEY STEVEN J	9535 SAND MYRTLE DR	COLORADO SPRINGS CO 80925-1113
31	SIMMONS KYLE B	9525 SAND MYRTLE DR	COLORADO SPRINGS CO 80925
32	NELSON THOMAS ANTHONY	9515 SAND MYRTLE DR	COLORADO SPRINGS CO 80925-1113
33	STANTON COY LUTHER	638 E WILLAMETTE AVE	COLORADO SPRINGS CO 80903
34	CUCHARS RANCH HOMEOWNERS ASSN INC	11002 BENTON ST	BROOMFIELD CO 80020-3286
35	KNOWLES STEVEN GLEN	9485 SAND MYRTLE DR	COLORADO SPRINGS CO 80925-1165

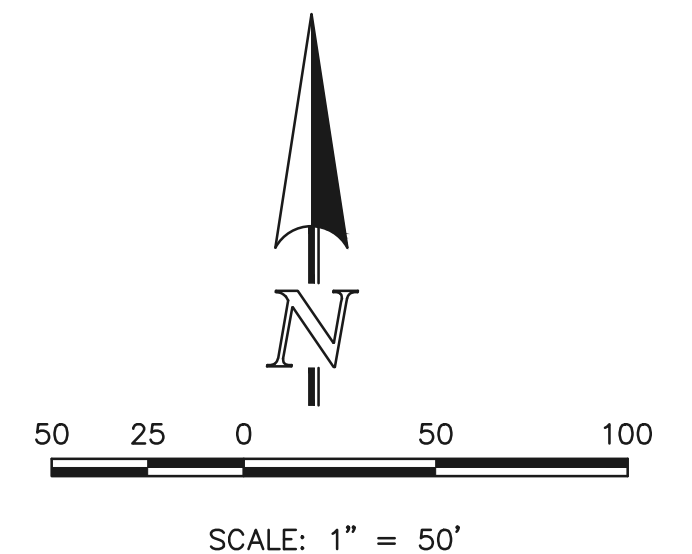

EL PASO COUNTY FILE NO.: SP243

CLASSIC CONSULTING
619 N. Cascade Avenue, Suite 200
Colorado Springs, Colorado 80903
(719)785-0790

**RISING MOON FILING NO. 1 & 2
PRELIMINARY PLAN**
LEGAL BOUNDARY & ADJACENT PROPERTY OWNERS EXHIBIT

DESIGNED BY	MES	SCALE	DATE	01/15/25
DRAWN BY	KES	(H) 1" = 50'	SHEET	2 OF 4
CHECKED BY		(V) 1" = N/A	JOB NO.	2506.03



N:\250603\SP243\AVI\AVI\DEVELOPMENT\PRELIM PLAN\02-250603\01 - PROP.dwg, 1/15/2025 4:00:52 PM, 1:1

RISING MOON FILING NO. 1 & 2

REPLAT TRACT B OF MORNING SUN I

EAST 1/2 OF SEC. 3, TOWNSHIP 15S, RANGE 65 WEST, COUNTY OF EL PASO, STATE OF COLORADO

PRELIMINARY PLAN

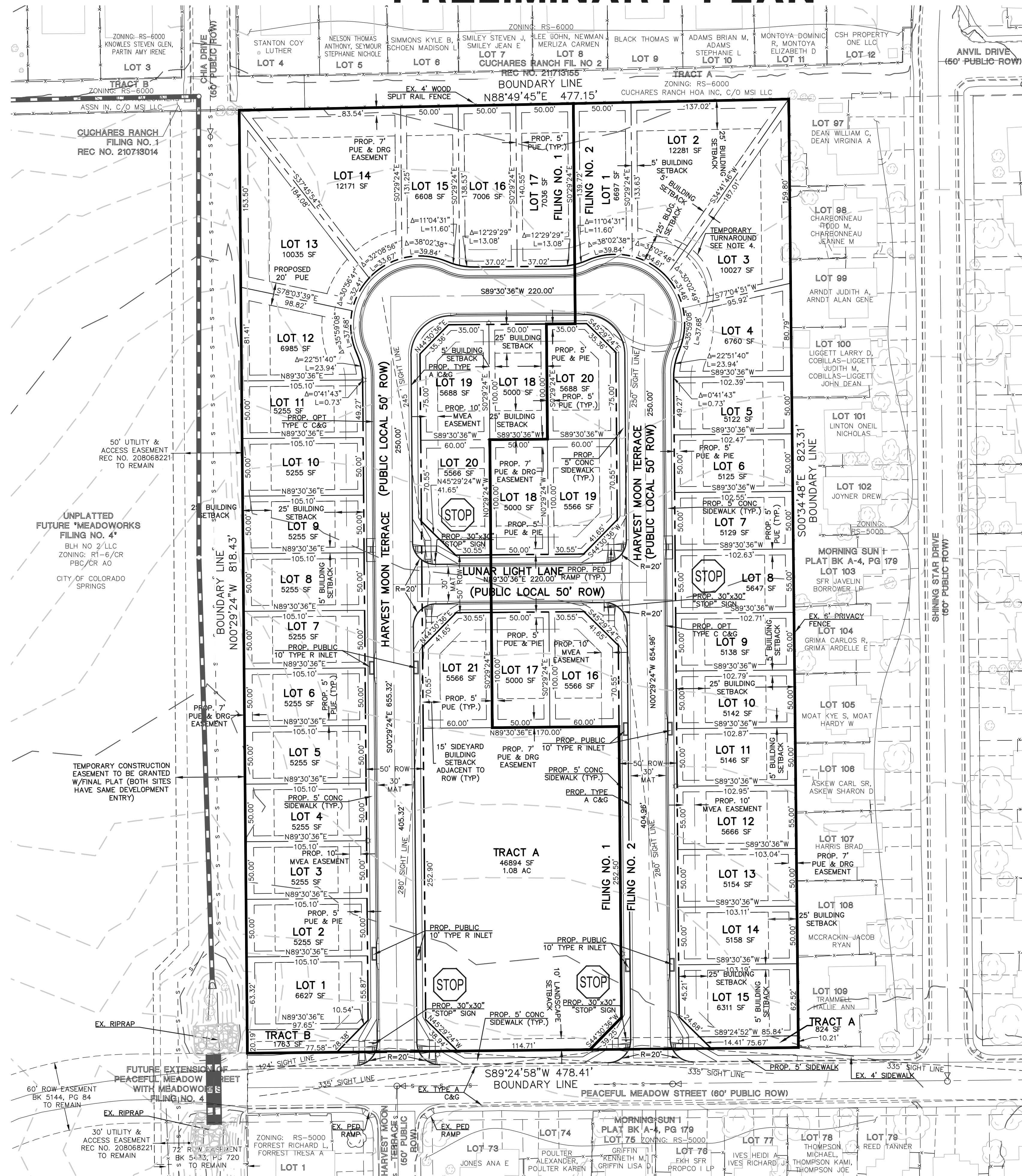

LEGEND

- EXISTING FIRE HYDRANT
- EXISTING WATER MAIN
- EXISTING SANITARY SEWER MAIN W/ MANHOLE
- PROPOSED STORM INLET
- EXISTING GAS MAIN
- EXISTING FENCE
- SETBACK
- MVEA EASEMENT
- LOT EASEMENT
- LOT SETBACK

- NOTES:
1. ALL TYPE C CURB & GUTTER IS THE OPTIONAL TYPE C CURB & GUTTER PER EPC STANDARDS.
 2. ALL PROPOSED PEDESTRIAN RAMPS, LANDINGS, AND CROSS SLOPES TO BE 2% MAXIMUM PER CURRENT EL PASO COUNTY ENGINEERING CRITERIA MANUAL.
 3. ALL PEDESTRIAN RAMPS/PATHS TO BE CONSTRUCTED IN ACCORDANCE WITH ECM CHAPTER 6. SEE ECM STANDARD DRAWINGS SD_2-40, 2-41, 2-42 AND 2-50.
 4. TEMPORARY TURNAROUND (AS SHOWN) SHALL BE CONSTRUCTED AT THE HARVEST MOON TERRACE FILING NO. 1 DEAD END IN ACCORDANCE WITH ECM CHAPTER 2.3, FIGURE 2-33. THE NON-REVOCABLE PUBLIC IMPROVEMENT EASEMENT SHOWN AT THE END OF HARVEST MOON TERRACE CUL-DE-SAC IS INTENDED FOR TURN AROUND AND EMERGENCY RESPONSE PURPOSES. AT SUCH A TIME THAT HARVEST MOON TERRACE IS EXTENDED BY THE ADJACENT PROPERTY OWNER/DEVELOPER AND ACCEPTED BY THE COUNTY, THE NON-REVOCABLE PUBLIC IMPROVEMENT EASEMENT FOR THE CUL-DE-SAC WILL BE VACATED, LEAVING A STANDARD STREET ROW AND THE CUL-DE-SAC IMPROVEMENTS WILL BE REMOVED AND REPLACED WITH A STANDARD STREET SECTION. THE EASEMENT VACATION, CUL-DE-SAC REMOVAL AND STANDARD STREET SECTION CONSTRUCTION AND SITE RESTORATION IS THE RESPONSIBILITY OF THE OWNER/DEVELOPER EXTENDING HARVEST MOON TERRACE.

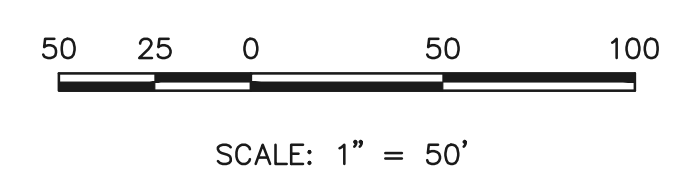
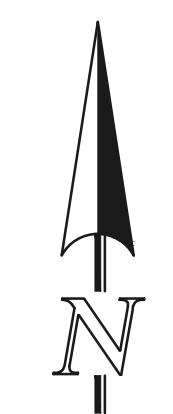

EL PASO COUNTY FILE NO.: SP243

CLASSIC CONSULTING

RISING MOON FILING NO. 1 & 2
PRELIMINARY PLAN
 PRELIMINARY SITE PLAN

DESIGNED BY	MES	SCALE	DATE	01/15/25
DRAWN BY	KES	(H) 1" = 50'	SHEET	3 OF 4
CHECKED BY	(V) 1" = N/A	JOB NO.	2506.03	

619 N. Cascade Avenue, Suite 200 (719)785-0790
 Colorado Springs, Colorado 80903

N:\250603\UPR\AMM\DEVELOPMENT\PRELIM PLAN\03-250603SP.dwg, 1/16/2025 9:33:55 AM, 1:1

RISING MOON FILING NO. 1 & 2

REPLAT TRACT B OF MORNING SUN I

EAST 1/2 OF SEC. 3, TOWNSHIP 15S, RANGE 65 WEST, COUNTY OF EL PASO, STATE OF COLORADO

PRELIMINARY PLAN

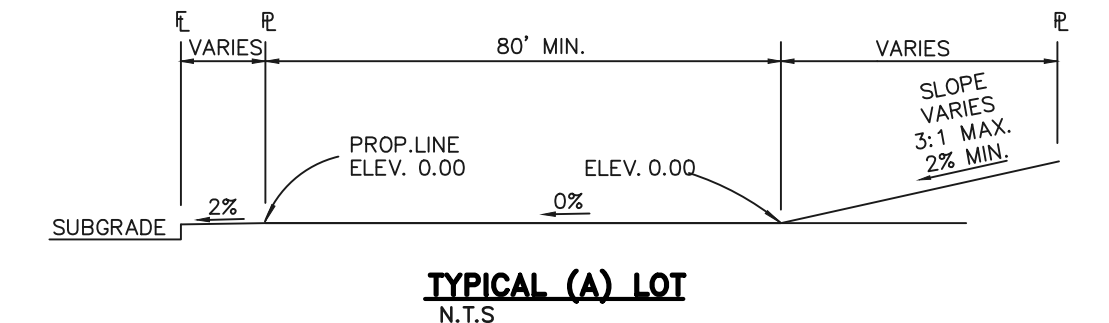
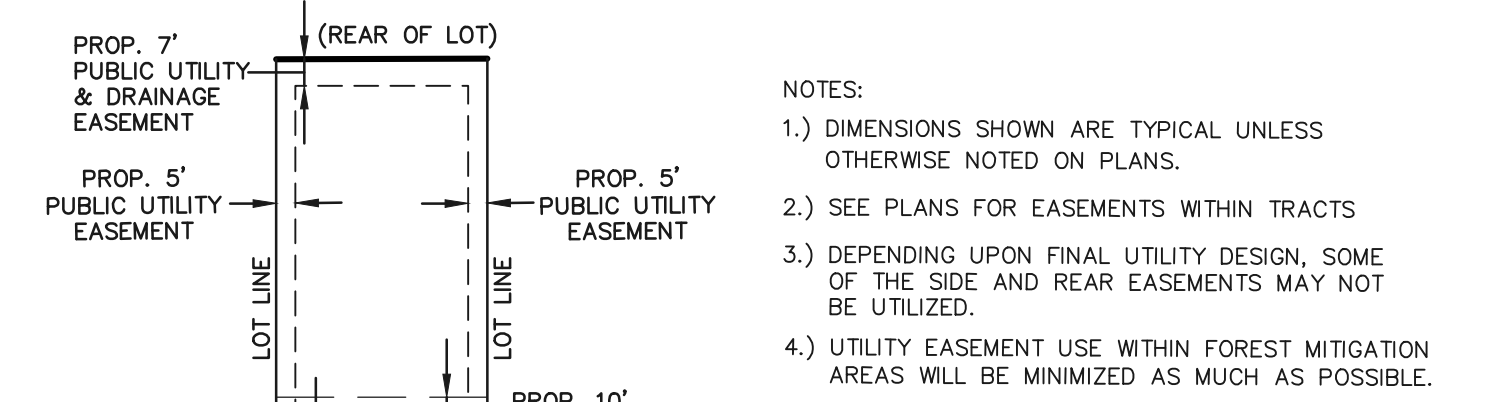

- NOTES:**
1. ALL TYPE C CURB & GUTTER IS THE OPTIONAL TYPE C CURB & GUTTER PER EPC STANDARDS.
 2. ALL PROPOSED PEDESTRIAN RAMPS, LANDINGS, AND CROSS SLOPES TO BE 2% MAXIMUM PER CURRENT EL PASO COUNTY ENGINEERING CRITERIA MANUAL.
 3. ALL PEDESTRIAN RAMPS/PATHS TO BE CONSTRUCTED IN ACCORDANCE WITH ECM CHAPTER 6. SEE ECM STANDARD DRAWINGS SD_2-40, 2-41, 2-42 AND 2-50.
 4. TEMPORARY TURNAROUND (AS SHOWN) SHALL BE CONSTRUCTED AT THE HARVEST MOON TERRACE FILING NO. 1 DEAD END IN ACCORDANCE WITH ECM CHAPTER 2.3, FIGURE 2-33. THE NON-REVOCABLE PUBLIC IMPROVEMENT EASEMENT SHOWN AT THE END OF HARVEST MOON TERRACE CUL-DE-SAC IS INTENDED FOR TURN AROUND AND EMERGENCY RESPONSE PURPOSES. AT SUCH A TIME THAT HARVEST MOON TERRACE IS EXTENDED BY THE ADJACENT PROPERTY OWNER/DEVELOPER AND ACCEPTED BY THE COUNTY, THE NON-REVOCABLE PUBLIC IMPROVEMENT EASEMENT FOR THE CUL-DE-SAC WILL BE VACATED, LEAVING A STANDARD STREET ROW AND THE CUL-DE-SAC IMPROVEMENTS WILL BE REMOVED AND REPLACED WITH A STANDARD STREET SECTION. THE EASEMENT VACATION, CUL-DE-SAC REMOVAL AND STANDARD STREET SECTION CONSTRUCTION AND SITE RESTORATION IS THE RESPONSIBILITY OF THE OWNER/DEVELOPER EXTENDING HARVEST MOON TERRACE.

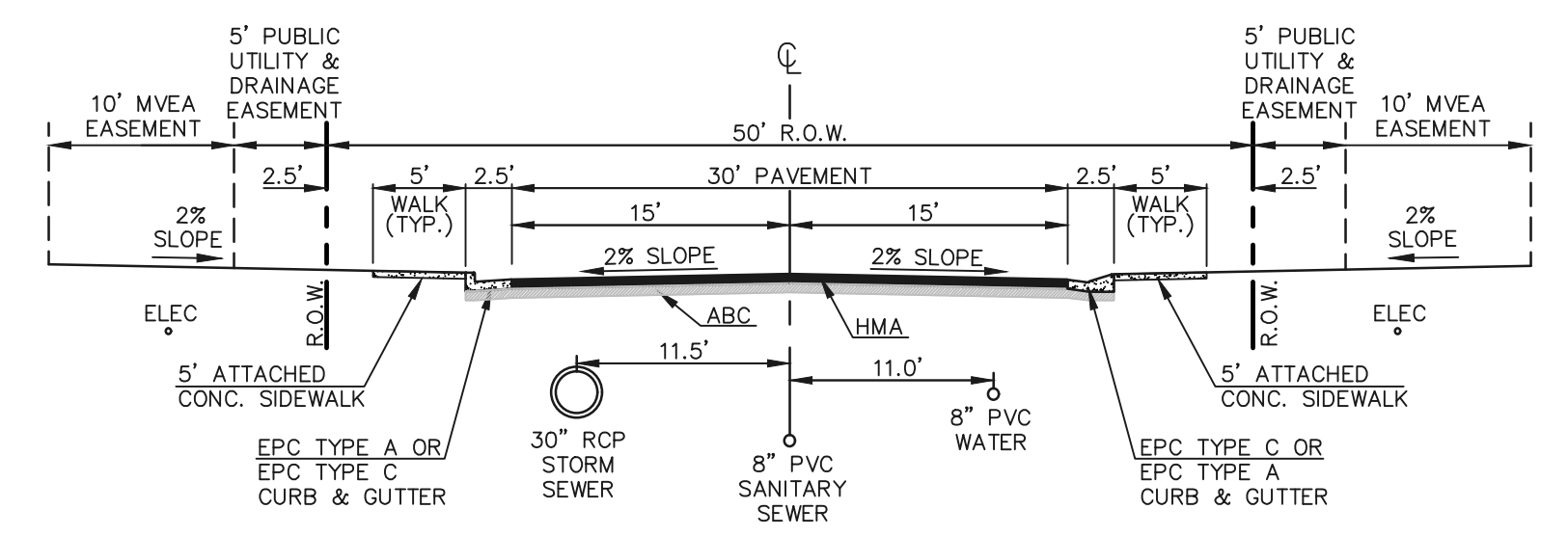

NOTE: THIS COMMUNITY WILL NOT REQUIRE GAS FACILITIES (HOMES ARE ALL ELECTRIC)

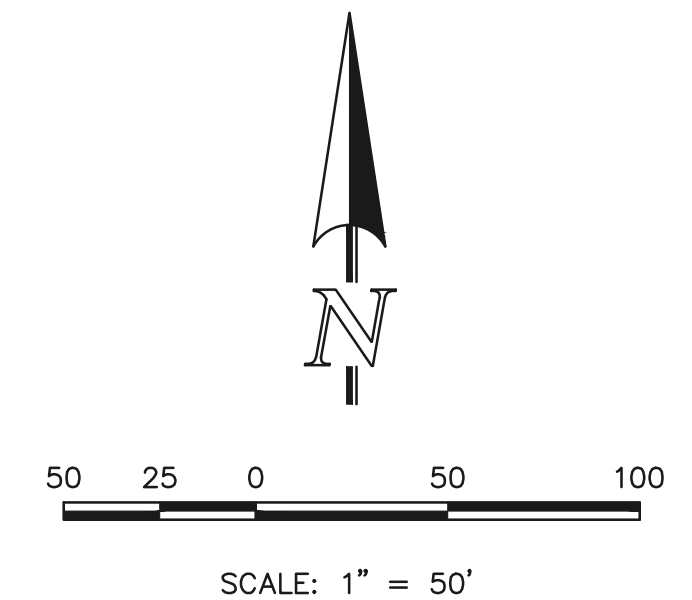

- LEGEND**
- PROPOSED CONTOUR-5
 - PROPOSED CONTOUR-1
 - EXISTING CONTOUR-5
 - EXISTING CONTOUR-1
 - EXISTING DIRECTION OF FLOW
 - PROPOSED DIRECTION OF FLOW
 - PROPOSED HIGH POINT
 - PROPOSED LOW POINT
 - EXISTING FIRE HYDRANT
 - EXISTING WATER MAIN
 - EXISTING SANITARY SEWER MAIN W/ MANHOLE
 - PROPOSED WATER MAIN
 - PROPOSED FIRE HYDRANT
 - PROPOSED STORM INLET
 - PROPOSED STORM SEWER
 - EXISTING STORM INLET
 - EXISTING STORM SEWER
 - PROPOSED SANITARY SEWER MAIN W/ MANHOLE
 - EXISTING GAS MAIN
 - EXISTING FENCE
 - SETBACK
 - MVEA EASEMENT
 - LOT EASEMENT

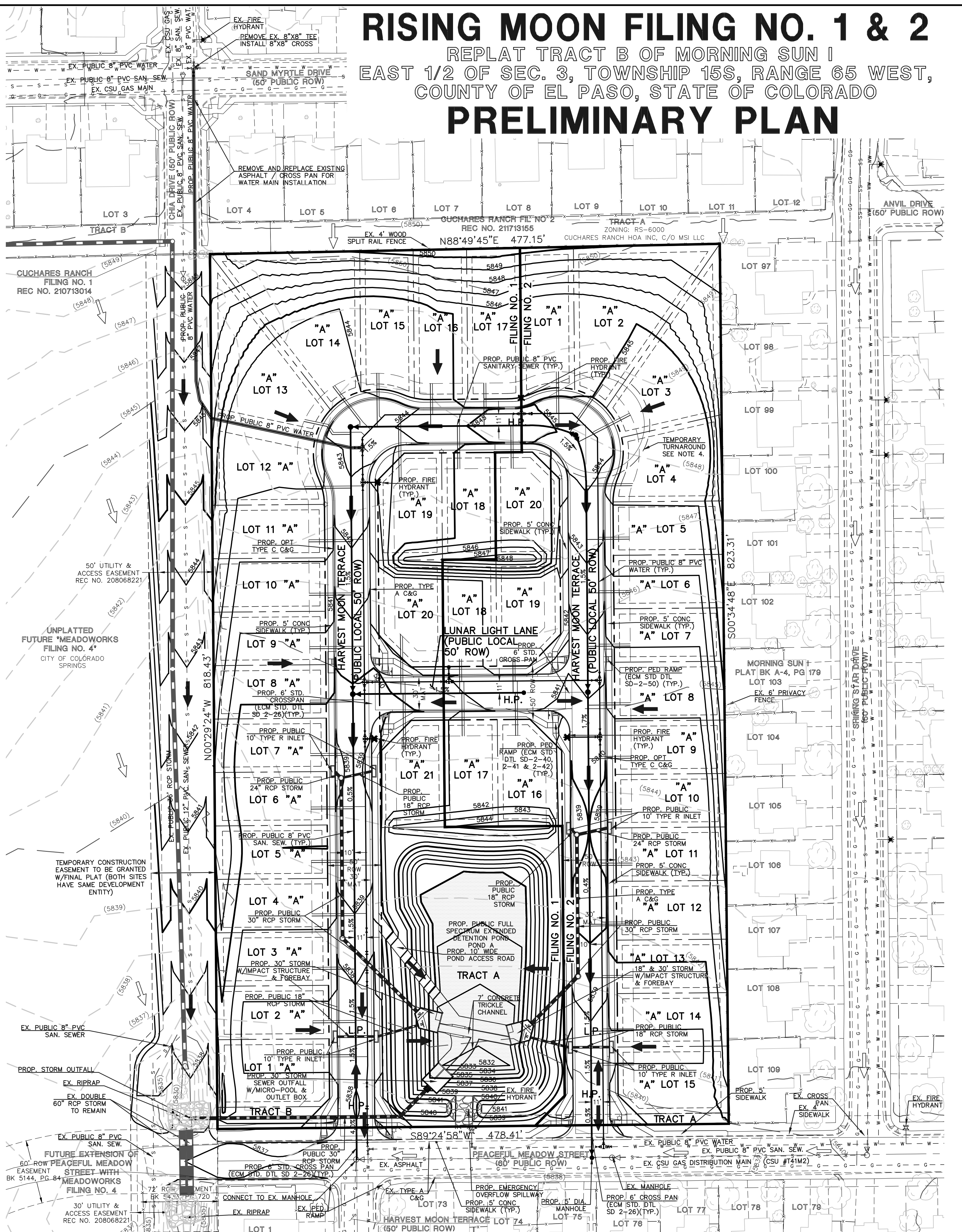

EL PASO COUNTY FILE NO.: SP243

CLASSIC CONSULTING

619 N. Cascade Avenue, Suite 200
Colorado Springs, Colorado 80903

RISING MOON FILING NO. 1 & 2

PRELIMINARY PLAN

PRELIMINARY GRADING & UTILITY PLAN

DESIGNED BY MES SCALE DATE 01/15/25

DRAWN BY KES (H) 1" = 50' SHEET 4 OF 4

CHECKED BY (V) 1" = N/A JOB NO. 2506.03

N:\250603\ORIG\AMCS\DEVELOPMENT\PRELIM PLAN\04-250603PG-PU.dwg, 1/16/2025 9:34:20 AM, 1:1

APPENDIX B

FORM NO.
GWS-76
05/2011

WATER SUPPLY INFORMATION SUMMARY
STATE OF COLORADO, OFFICE OF THE STATE ENGINEER
1313 Sherman St., Room 821, Denver, CO 80203
Main (303) 866-3581 dwr.colorado.gov

Section 30-28-133,(d), C.R.S. requires that the applicant submit to the County, "Adequate evidence that a water supply that is sufficient in terms of quantity, quality, and dependability will be available to ensure an adequate supply of water."

1. NAME OF DEVELOPMENT AS PROPOSED: Rising Moon Filing No. 1 & 2

2. LAND USE ACTION: Subdivide Tract B to Single Family Lots (41)- Prelim Plan

3. NAME OF EXISTING PARCEL AS RECORDED:
SUBDIVISION: Tract B, Morning Sun 1, FILING (UNIT) _____, BLOCK _____, LOT _____

4. TOTAL ACREAGE: 9.0 | 5. NUMBER OF LOTS PROPOSED 41 | PLAT MAP ENCLOSED? YES or NO

6. PARCEL HISTORY – Please attach copies of deeds, plats, or other evidence or documentation.

- A. Was parcel recorded with county prior to June 1, 1972? YES or NO
 - B. Has the parcel ever been part of a division of land action since June 1, 1972? YES or NO
- If yes, describe the previous action:

7. LOCATION OF PARCEL – Include a map delineating the project area and tie to a section corner.

_____ 1/4 of the _____ 1/4, Section 3, Township 15 N or S, Range 65 E or W
Principal Meridian (choose only one): Sixth New Mexico Ute Costilla

Optional GPS Location: GPS Unit must use the following settings: Format must be **UTM**, Units must be **meters**, Datum must be **NAD83**, Unit must be set to **true N**, Zone 12 or Zone 13
Easting: _____
Northing: _____

8. PLAT – Location of all wells on property must be plotted and permit numbers provided.

Surveyor's Plat: YES or NO | If not, scaled hand drawn sketch: YES or NO | N/A

9. ESTIMATED WATER REQUIREMENTS | 10. WATER SUPPLY SOURCE

USE	WATER REQUIREMENTS		<input type="checkbox"/> EXISTING WELL <input type="checkbox"/> DEVELOPED SPRING WELL PERMIT NUMBERS _____ _____ _____	<input type="checkbox"/> NEW WELLS - PROPOSED AQUIFERS – (CHECK ONE) <input type="checkbox"/> ALLUVIAL <input type="checkbox"/> UPPER ARAPAHOE <input type="checkbox"/> UPPER DAWSON <input type="checkbox"/> LOWER ARAPAHOE <input type="checkbox"/> LOWER DAWSON <input type="checkbox"/> LARAMIE FOX HILLS <input type="checkbox"/> DENVER <input type="checkbox"/> DAKOTA <input type="checkbox"/> OTHER: _____
	Gallons per Day	Acre-Feet per Year		
HOUSEHOLD USE # <u>41</u> of units	<u>9,511</u>	<u>10.660</u>		
COMMERCIAL USE # <u>0</u> of S. F	_____	_____		
2,245sf/unit = 92,045sf IRRIGATION # _____ of acres <u>2.11</u>	<u>4,649</u>	<u>5.211</u>		
STOCK WATERING # <u>0</u> of head	_____	_____	<input type="checkbox"/> MUNICIPAL <input type="checkbox"/> ASSOCIATION <input type="checkbox"/> COMPANY <input checked="" type="checkbox"/> DISTRICT NAME <u>Colorado Centre</u> LETTER OF COMMITMENT FOR SERVICE <input type="checkbox"/> YES or <input type="checkbox"/> NO	WATER COURT DECREE CASE NUMBERS: _____ _____ _____
OTHER: _____	_____	_____		
TOTAL	<u>14,160</u>	<u>15.871</u>		

11. WAS AN ENGINEER'S WATER SUPPLY REPORT DEVELOPED? YES or NO IF YES, PLEASE FORWARD WITH THIS FORM.
(This may be required before our review is completed.)

12. TYPE OF SEWAGE DISPOSAL SYSTEM

- SEPTIC TANK/LEACH FIELD
- LAGOON
- ENGINEERED SYSTEM (Attach a copy of engineering design.)
- CENTRAL SYSTEM
DISTRICT NAME: Colorado Centre Metro District
- VAULT
LOCATION SEWAGE HAULED TO: _____
- OTHER:

APPENDIX C



Colorado Centre Metropolitan District

9686 Flagstone Street, Colorado Springs, Colorado 80925

Telephone: 719-390-7000

E-mail: customerservice@coloradocentre.org Web: www.coloradocentre.org

March 18, 2025

Kylie Bagley, Project Manager
El Paso County Planning and Community Development Department
Transmitted via EDARP portal: epcdevplanreview.com

Re: Habitat for Humanity Preliminary Plan (AKA Rising Moon Filing 1 and 2)
File No.: SP243
Part of Sec. 3, T15S, R65W of the 6th PM
CDWR Assigned Subdivision No. 32443 – 2nd letter.

Dear Kylie Bagley,

In response to the letter from Ivan Franco, P.E., of the State of Colorado's Division of Water Resources, I have the following comments:

Colorado Centre Metropolitan District (CCMD or District) bases its connection fees and/or taps on the demand volumes required by the State for planning purposes. For residential uses, that number is 0.24 gallons per minute or 345.6 gallons per day, or 126,144 gallons per year or 0.3871 ac-ft per year. Which for 41 single family units totals 15.8711 ac-ft per year total. This amount of water is included in the 599.66 ac-ft per year that the District has allocated to the existing and future developments from its water entitlements of 849 ac-ft/yr that are shown in the attached Water Availability Database. This means that the District has 249.34 ac-ft/yr of water that is uncommitted and, furthermore, the District has no additional development areas. In fact, there's one more parcel that may be seeking annexation to Colorado Springs which should further reduce the District's obligation to supply water. The attached database has been updated as of March 2025 and should replace all previous databases provided.

In summary, the District, upon payment of the appropriate taps and connection fees by the developer, commits to servicing this development with 15.8711 ac-ft/year of potable water. Thank you.

Cordially,

Alvaro J. Testa, District Manager

Attachment: Water Availability Report Updated March 2025

Transmitted through EDARP Portal

AVERAGE WATER DEMANDS FOR ALL LAND USES WITHIN THE COLORADO CENTRE METROPOLITAN DISTRICT'S UNINCORPORATED AREAS

COUNTY ASSESSOR NUMBER	DESCRIPTION	USE	STATUS	GROSS AREA (ACRE)	GROSS AREA (SF)	F.A.R.	USABLE AREA (SF)	DENSITY UNIT PER ACRE	TOTAL UNITS	CONSUMPTION FACTOR (SEE NOTES)	ESTIMATED AVERAGE WATER DEMAND (GPM)
55044-01-001	WIDEFIELD S. D. 3	BP	PLATTED				46,656			8.42E-05	3.93
55032-01-001	HARRIS	BP	PLATTED				42,984			8.42E-05	3.62
55091-02-001	HARRIS - 2 BUILDINGS	BP	PLATTED				70,280			8.42E-05	5.92
55091-00-004	WIDEFIELD S. D. 3	BP	UN-PLATTED	13.2	574,992	0.02	10,000			8.42E-05	0.84
55091-00-005	STOEN	BP	UN-PLATTED	19.27	839,401	0.35	293,790			8.42E-05	24.74
VARIES	COLO. CTR. RES. No. 1	SF	PLATTED						22	0.24	5.28
VARIES	COLO. CTR. RES. No. 2	SF	PLATTED						150	0.24	36.00
VARIES	COLO. CTR. RES. No. 3	SF	PLATTED						89	0.24	21.36
VARIES	COLO. CTR. RES. No. 4	SF	PLATTED						87	0.24	20.88
VARIES	COLO. CTR. RES. No. 5	SF	PLATTED						73	0.24	17.52
VARIES	COLO. CTR. RES. No. 6	SF	PLATTED						82	0.24	19.68
VARIES	MORNING SUN I	SF	PLATTED						109	0.24	26.16
VARIES	MORNING SUN II	SF	PLATTED						130	0.24	31.20
VARIES	MORNING SUN II	SF	VACATED						-25	0.24	-6.00
VARIES	CUCHARES FILING 1	SF	PLATTED						112	0.24	26.88
VARIES	CUCHARES FILING 2	SF	PLATTED						30	0.24	7.20
VARIES	CUCHARES FILING 3	SF	PLATTED						27	0.24	6.48
VARIES	CUCHARES FILING 4	SF	PLATTED						54	0.24	12.96
VARIES	CUCHARES FILING 5	SF	PLATTED						70	0.24	16.80
VARIES	CUCHARES FILING 6	SF	PLATTED						61	0.24	14.64
VARIES	CUCHARES FILING 7	SF	PLATTED						55	0.24	13.20
VARIES	CUCHARES LANDSCAPING	OS	ROW	1						1.52	1.52
55034-00-003	CCMD ADMIN BLDG & PLANT	BP	UN-PLATTED		336,719	0.04	15,000			8.42E-05	1.26
VARIES	CCMD OS/PARKS	SF	UN-PLATTED	24.2						1.52	36.78
55031-01-010	RISING MOON F1&2	ES	PLATTED						41	0.24	9.84
55034-17-026	COLO. CTR. RES. - SCHOOL	ES	PLATTED	9.23						1.30	12.00
55102-00-003	CCMD FIRE STATION/FLUSH	FS	BUILT/JUNPLAT	1						1.05	1.05

WATER CURRENTLY IN USE (GPM)	WATER COMMITTED (GPM)
3.93	
3.62	
5.92	
0.84	
24.74	24.74
5.28	
36.00	
21.36	
20.88	
17.52	
19.68	
26.16	
31.20	
-6.00	
26.88	
7.20	
6.48	
12.96	
16.80	
14.64	
13.20	
1.60	
1.26	
36.78	
9.84	9.84
12.00	12.00
1.05	

371.74 GPM
 OR 195,386,763 GAL / YR
 OR 599.66 AC-FT/YR

325.24 GPM
 170,948,385 GAL / YR
 524.66 AC-FT/YR

46.58 GPM
 24,480,426 GAL / YR
 75.13 AC-FT/YR

1167 SF
 194 SFE
 1361 SFE

CONSUMABLE AVAILABLE WATER	
CASE 86CW31 :	420 AC-FT/YR
CASE 07CW47 :	154 AC-FT/YR
CASE 20CW3053:	7 AC-FT/YR
ROBINSON (#13):	268 AC-FT/YR
TOTAL :	849 AC-FT/YR

NOTES:

THE FOLLOWING ARE THE COMPUTATIONS OF THE FACTORS USED TO DETERMINE THE AVERAGE WATER DEMAND FOR EACH LAND USE.

BP	(1 PERSON / 165 SF)(20 GAL / PERSON / DAY)(1 DAY / 1440 MINUTES) =	8.42E-05	GPM/PERSON
SF	(3.5 PERSONS / UNIT)(100 GAL / DAY / PERSON)(1 DAY / 1440 MINUTES) =	0.24	GPM/SF
SFS	(3.5 PERSONS / UNIT)(70 GAL / DAY / PERSON)(1 DAY / 1440 MINUTES) =	0.17	GPM/UNIT
MHP	(2.5 PERSONS / UNIT)(100 GAL / DAY / PERSON)(1 DAY / 1440 MINUTES) =	0.17	GPM/UNIT
ES	(1872 GAL / DAY / ACRE)(1 DAY / 1440 MINUTES) =	1.30	GPM/UNIT
P	(2.46 ACRE-FEET / ACRE / YEAR)(43,560 SF / ACRE)(7.48 GAL / CF)(1 YEAR / (365*1440) MINUTES) =	1.52	GPM/ACRE

APPENDIX D

**AVERAGE WATER DEMANDS FOR ALL LAND USES WITHIN THE
COLORADO CENTRE METROPOLITAN DISTRICT'S UNINCORPORATED AREAS**

COUNTY ASSESSOR NUMBER	DESCRIPTION	USE	STATUS	GROSS AREA (ACRE)	GROSS AREA (SF)	F.A.R.	USABLE AREA (SF)	DENSITY UNIT PER ACRE	TOTAL UNITS	CONSUMPTION FACTOR (SEE NOTES)	ESTIMATED AVERAGE WATER DEMAND (GPM)	WATER CURRENTLY IN USE (GPM)	WATER COMMITTED (GPM)				
55044-01-001	WIDEFIELD S. D. 3	BP	PLATTED				46,656			8.42E-05	3.93	3.93					
55032-01-001	HARRIS	BP	PLATTED				42,984			8.42E-05	3.62	3.62					
55091-02-001	HARRIS - 2 BUILDINGS	BP	PLATTED				70,280			8.42E-05	5.92	5.92					
55091-00-004	WIDEFIELD S. D. 3	BP	UN-PLATTED	13.2	574,992	0.02	10,000			8.42E-05	0.84	0.84					
55091-00-005	STOEN	BP	UN-PLATTED	19.27	839,401	0.35	293,790			8.42E-05	24.74		24.74				
VARIES	COLO. CTR. RES. No. 1	SF	PLATTED						22	0.24	5.28	5.28					
VARIES	COLO. CTR. RES. No. 2	SF	PLATTED						150	0.24	36.00	36.00					
VARIES	COLO. CTR. RES. No. 3	SF	PLATTED						89	0.24	21.36	21.36					
VARIES	COLO. CTR. RES. No. 4	SF	PLATTED						87	0.24	20.88	20.88					
VARIES	COLO. CTR. RES. No. 5	SF	PLATTED						73	0.24	17.52	17.52					
VARIES	COLO. CTR. RES. No. 6	SF	PLATTED						82	0.24	19.68	19.68					
VARIES	MORNING SUN I	SF	PLATTED						109	0.24	26.16	26.16					
VARIES	MORNING SUN II	SF	PLATTED						130	0.24	31.20	31.20					
VARIES	MORNING SUN II	SF	VACATED						-25	0.24	-6.00	-6.00					
VARIES	CUCHARS FILING I	SF	PLATTED						112	0.24	26.88	26.88					
VARIES	CUCHARS FILING 2	SF	PLATTED						30	0.24	7.20	7.20					
VARIES	CUCHARS FILING 3	SF	PLATTED						27	0.24	6.48	6.48					
VARIES	CUCHARS FILING 4	SF	PLATTED						54	0.24	12.96	12.96					
VARIES	CUCHARS FILING 5	SF	PLATTED						70	0.24	16.80	16.80					
VARIES	CUCHARS FILING 6	SF	PLATTED						61	0.24	14.64	14.64					
VARIES	CUCHARS FILING 7	SF	PLATTED						55	0.24	13.20	13.20					
VARIES	CUCHARS LANDSCAPING	OS	ROW	1						1.52	1.52	1.60					
55034-00-003	CCMD ADMIN BLDG & PLANT	BP	UN-PLATTED		336,719	0.04	15,000			8.42E-05	1.26	1.26					
VARIES	CCMD OS/PARKS	SF	UN-PLATTED	24.2						1.52	36.78	36.78					
55031-01-010	RISING MOON F1&2	ES	PLATTED						41	0.24	9.84		9.84				
55034-17-026	COLO. CTR. RES. - SCHOOL	ES	PLATTED	9.23						1.30	12.00		12.00				
55102-00-003	CCMD FIRE STATION/FLUSH	FS	BUILT/UNPLAT	1						1.05	1.05	1.05					
											371.74	GPM	325.24	GPM	46.58	GPM	
											OR	195,386,763	GAL / YR	170,948,385	GAL / YR	24,480,426	GAL / YR
											OR	599.66	AC-FT/YR	524.66	AC-FT/YR	75.13	AC-FT/YR

1167 SF
194 SFE

1361 SFE

CONSUMABLE AVAILABLE WATER	
CASE 86CW31 :	420 AC-FT/YR
CASE 07CW47 :	154 AC-FT/YR
CASE 20CW3053:	7 AC-FT/YR
ROBINSON (#13):	268 AC-FT/YR
TOTAL :	849 AC-FT/YR

NOTES:

THE FOLLOWING ARE THE COMPUTATIONS OF THE FACTORS USED TO DETERMINE THE AVERAGE WATER DEMAND FOR EACH LAND USE.

BP	(1 PERSON / 165 SF)(20 GAL / PERSON / DAY)(1DAY / 1440 MINUTES) =	8.42E-05	GPM/PERSON
SF	(3.5 PERSONS / UNIT)(100 GAL / DAY / PERSON)(1 DAY / 1440 MINUTES) =	0.24	GPM/SF
SFS	(3.5 PERSONS / UNIT)(70 GAL / DAY / PERSON)(1 DAY / 1440 MINUTES) =	0.17	GPM/UNIT
MHP	(2.5 PERSONS / UNIT)(100 GAL / DAY / PERSON)(1 DAY / 1440 MINUTES) =	0.17	GPM/UNIT
ES	(1872 GAL / DAY / ACRE)(1 DAY / 1440 MINUTES) =	1.30	GPM/UNIT
P	(2.46 ACRE-FEET / ACRE / YEAR)(43,560 SF / ACRE)(7.48 GAL / CF)(1 YEAR / (365*1440) MINUTES) =	1.52	GPM/ACRE

APPENDIX E

RISING MOON FILING NO. 1 & 2

REPLAT TRACT B OF MORNING SUN I

EAST 1/2 OF SEC. 3, TOWNSHIP 15S, RANGE 65 WEST, COUNTY OF EL PASO, STATE OF COLORADO

PRELIMINARY PLAN

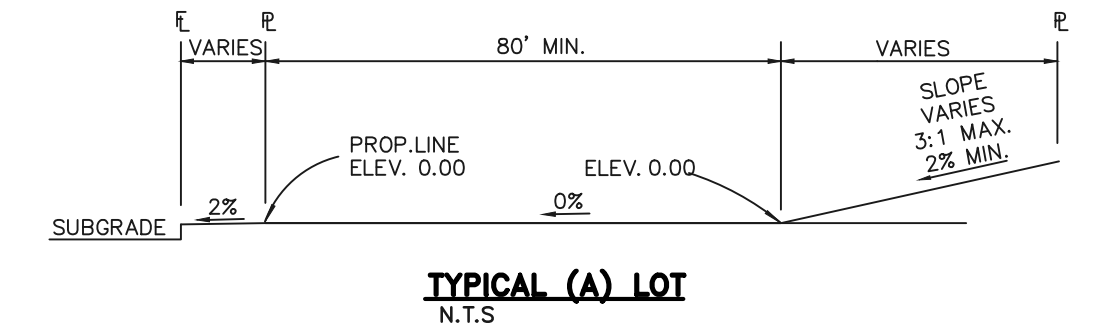
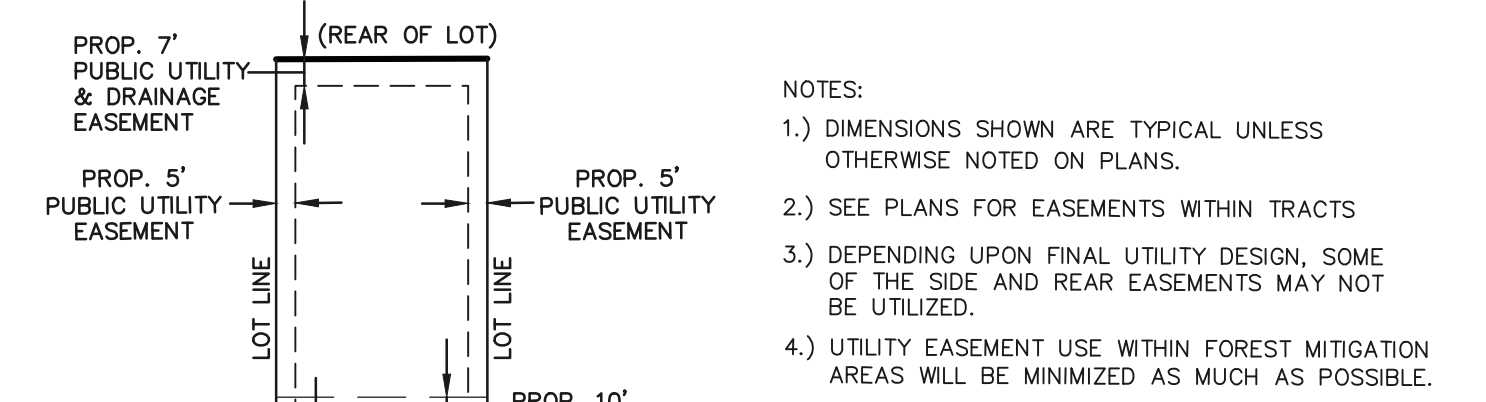

- NOTES:**
1. ALL TYPE C CURB & GUTTER IS THE OPTIONAL TYPE C CURB & GUTTER PER EPC STANDARDS.
 2. ALL PROPOSED PEDESTRIAN RAMPS, LANDINGS, AND CROSS SLOPES TO BE 2% MAXIMUM PER CURRENT EL PASO COUNTY ENGINEERING CRITERIA MANUAL.
 3. ALL PEDESTRIAN RAMPS/PATHS TO BE CONSTRUCTED IN ACCORDANCE WITH ECM CHAPTER 6. SEE ECM STANDARD DRAWINGS SD_2-40, 2-41, 2-42 AND 2-50.
 4. TEMPORARY TURNAROUND (AS SHOWN) SHALL BE CONSTRUCTED AT THE HARVEST MOON TERRACE FILING NO. 1 DEAD END IN ACCORDANCE WITH ECM CHAPTER 2.3, FIGURE 2-33. THE NON-REVOCAABLE PUBLIC IMPROVEMENT EASEMENT SHOWN AT THE END OF HARVEST MOON TERRACE CUL-DE-SAC IS INTENDED FOR TURN AROUND AND EMERGENCY RESPONSE PURPOSES. AT SUCH A TIME THAT HARVEST MOON TERRACE IS EXTENDED BY THE ADJACENT PROPERTY OWNER/DEVELOPER AND ACCEPTED BY THE COUNTY, THE NON-REVOCAABLE PUBLIC IMPROVEMENT EASEMENT FOR THE CUL-DE-SAC WILL BE VACATED, LEAVING A STANDARD STREET ROW AND THE CUL-DE-SAC IMPROVEMENTS WILL BE REMOVED AND REPLACED WITH A STANDARD STREET SECTION. THE EASEMENT VACATION, CUL-DE-SAC REMOVAL AND STANDARD STREET SECTION CONSTRUCTION AND SITE RESTORATION IS THE RESPONSIBILITY OF THE OWNER/DEVELOPER EXTENDING HARVEST MOON TERRACE.

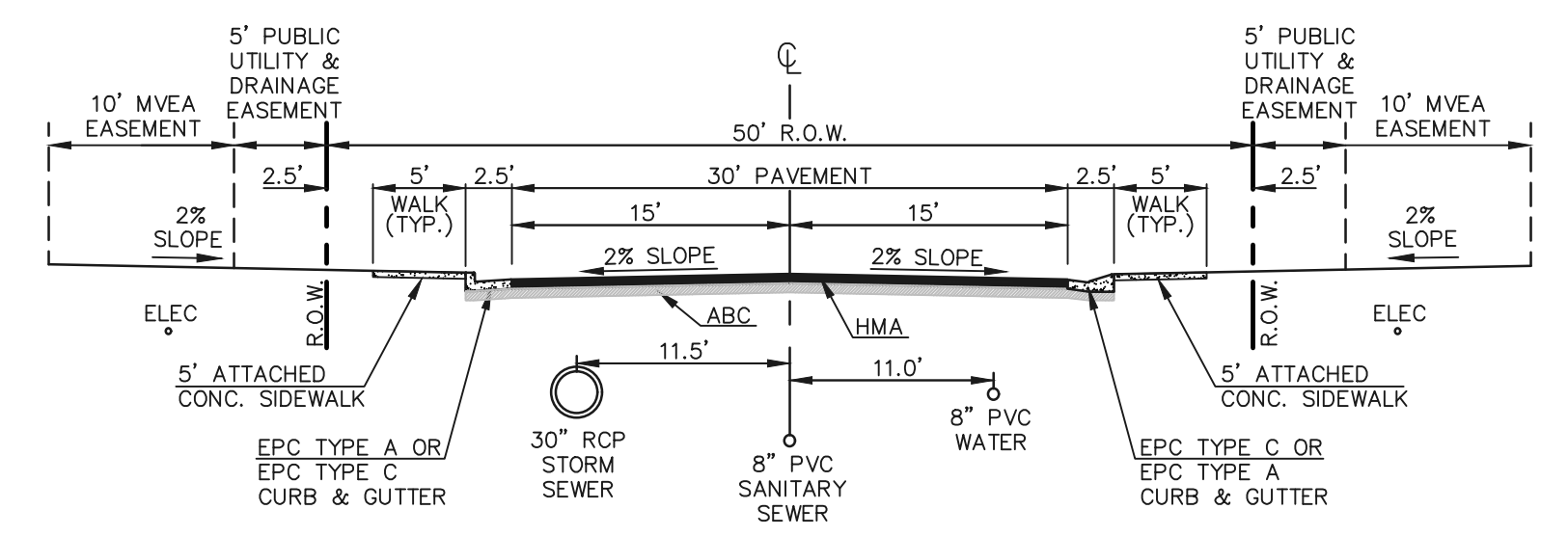

NOTE: THIS COMMUNITY WILL NOT REQUIRE GAS FACILITIES (HOMES ARE ALL ELECTRIC)

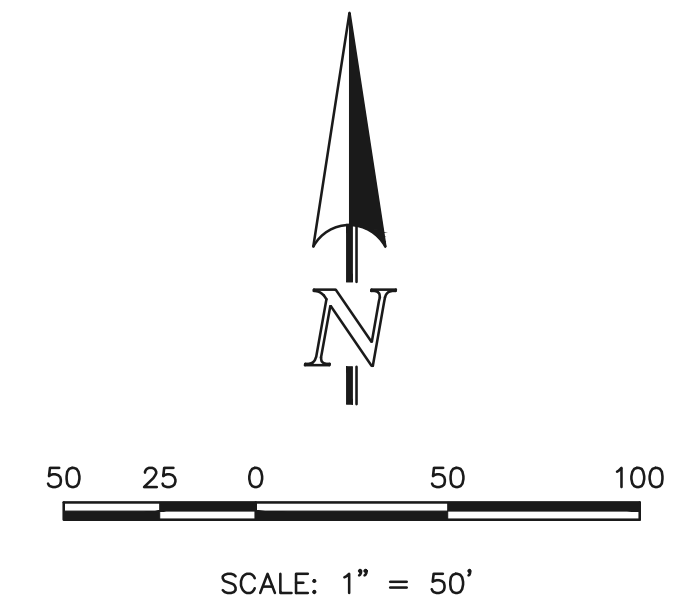

- LEGEND**
- PROPOSED CONTOUR-5
 - PROPOSED CONTOUR-1
 - EXISTING CONTOUR-5
 - EXISTING CONTOUR-1
 - EXISTING DIRECTION OF FLOW
 - PROPOSED DIRECTION OF FLOW
 - PROPOSED HIGH POINT
 - PROPOSED LOW POINT
 - EXISTING FIRE HYDRANT
 - EXISTING WATER MAIN
 - EXISTING SANITARY SEWER MAIN W/ MANHOLE
 - PROPOSED WATER MAIN
 - PROPOSED FIRE HYDRANT
 - PROPOSED STORM INLET
 - PROPOSED STORM SEWER
 - EXISTING STORM INLET
 - EXISTING STORM SEWER
 - PROPOSED SANITARY SEWER MAIN W/ MANHOLE
 - EXISTING GAS MAIN
 - EXISTING FENCE
 - SETBACK
 - MVEA EASEMENT
 - LOT EASEMENT

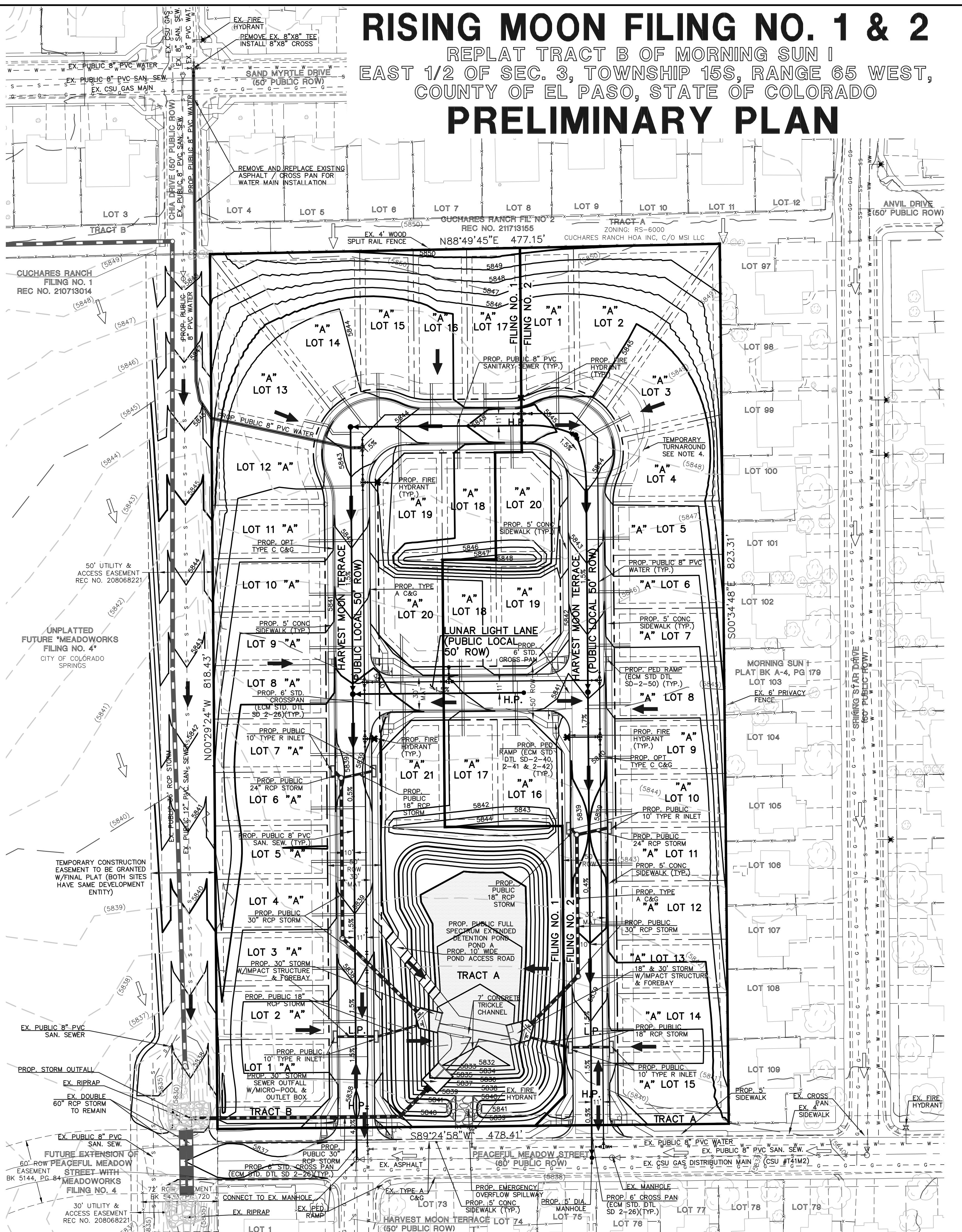

EL PASO COUNTY FILE NO.: SP243

CLASSIC CONSULTING

619 N. Cascade Avenue, Suite 200
Colorado Springs, Colorado 80903

RISING MOON FILING NO. 1 & 2
PRELIMINARY PLAN
PRELIMINARY GRADING & UTILITY PLAN

DESIGNED BY	MES	SCALE	DATE	01/15/25
DRAWN BY	KES	(H) 1" = 50'	SHEET	4 OF 4
CHECKED BY	(V) 1" = N/A	JOB NO.	2506.03	

APPENDIX F

COLORADO CENTRE BOUNDARY MAP

