



INNOVATIVE DESIGN. CLASSIC RESULTS.

**STORMWATER MANAGEMENT PLAN
FOR
BENT GRASS EAST COMMERCIAL FILING NO. 3**

SF-21-XXX



SF2147

Prepared for:

LAND FIRST, INC.

1378 PROMONTORY BLUFF VIEW

COLORADO SPRINGS, CO 80921

Prepared by:

Classic Consulting Engineers & Surveyors

619 N. Cascade Ave., Suite 200

Colorado Springs, CO 80903

(719) 785-0790

Job No. 2177.64

Qualified Stormwater Manager:

Contractor:



COLORADO DISCHARGE PERMIT SYSTEM STATEMENT (CDPS)/
EROSION AND STORMWATER QUALITY CONTROL PLAN (ESQCP)

Site Inspector

The following Erosion and Stormwater Quality Control Plan (ESQCP) is a detailed account of the requirements of the City of Colorado Springs El Paso County Drainage Criteria Manual, Volume 2 – Stormwater Quality Policies, Procedures and Best Management Practices as amended by the ECM. The main objective of this plan is to help mitigate the increased soil erosion and subsequent deposition of sediment off-site and other potential stormwater quality impacts during the period of construction from start of earth disturbance until final landscaping and other potential permanent stormwater quality measures are effectively in place.

This document must be kept at the construction site at all times and be made available to the public and any representative of the Colorado Department of Health - Water Quality Control Division, if requested.

This report is also proposed to meet all requirements of the Colorado Discharge Permit System for Construction Activity. If any discrepancies between this report and Volume 2 exist, the City/County Manual will prevail.

STORMWATER MANAGEMENT PLAN FOR
BENT GRASS EAST COMMERCIAL FILING NO. 3

TABLE OF CONTENTS

➤ SITE DESCRIPTION	4
▪ RECEIVING WATER(S)	5
▪ PROPOSED CONSTRUCTION ACTIVITY	5
▪ PROPOSED SEQUENCE OF ACTIVITIES/ CONSTRUCTION TIMING	5
▪ EROSION & SEDIMENT CONTROL	6
▪ DEVELOPMENT AREA	6
▪ SOILS INFORMATION	6
▪ EXISTING SITE CONDITIONS.	7
➤ SITE MAP (See Appendix)	7
➤ STORMWATER MANAGEMENT CONTROLS	8
▪ QUALIFIED STORMWATER MANAGER	8
▪ POTENTIAL POLLUTANT SOURCES	8
▪ BMPS FOR POLLUTION PREVENTION	9
▪ BMP SELECTION	10
▪ MATERIAL HANDLING & SPILL PREVENTION	10
▪ CONCRETE/ASPHALT BATCH PLANTS	11
▪ WASTE MANAGEMENT & DISPOSAL INCLUDING CONCRETE WASHOUT	11
▪ DOCUMENTING SELECTED BMPS	11
▪ NON-STORMWATER DISCHARGES	11
▪ STORMWATER DEWATERING	11
▪ REVISING BMPS AND THE SWMP	12
➤ FINAL STABILIZATION AND LONG-TERM STORMWATER MGMT	12
➤ INSPECTION AND MAINTENANCE PROCEDURES	13
▪ SWMP MANAGER INSPECTION PROCEDURES & SCHEDULES	13
▪ BMP MAINTENANCE/REPLACEMENT & FAILED BMPS	14
▪ RECORD KEEPING AND DOCUMENTING INSPECTIONS	14
➤ EROSION CONTROL COST OPINION	15

APPENDIX

VICINITY MAP

COPY OF GENERAL PERMIT APPLICATION

CONTRACTOR SEQUENCE OF ACTIVITIES

OPERATION & MAINTENANCE INSPECTION RECORD

STANDARD BMP DETAILS w/ INSTALLATION & MAINTENANCE REQUIREMENTS



SITE DESCRIPTION

Bent Grass East Commercial Filing No. 3 has a total acreage of 5.048 acres located in Section 1, Township 13 South, Range 65 West of the Sixth Principal Meridian in the County of El Paso, and State of Colorado. This site is bounded on the north by Bent Grass Meadows Drive, on the south by an existing private detention facility, on the west by Bent Grass Residential Filing No. 1 (Residential use) and to the east by Meridian Park Dr. The property is zoned CS. 6 commercial lots and a private roadway are planned within this plat. Portions of this site were previously overlotted graded along with the surrounding developments. The intent of this plat and associated CD's are to allow for the construction of the private roadway and associated grading and utility installations stubbed to each lot. Separate individual lot site plans must be submitted, reviewed and approved by the County prior to any vertical development. The private roadway and all lot development will drain to the existing EDB due south of this property constructed with Bent Grass Residential Filing No. 1.

Based on a field investigation, the property was indeed previously overlotted graded and contains primarily short field grasses. The Natural Resource Conservation Service has mapped the general soil type as gravelly sandy loam. More specifically described as Type 19, Columbine gravelly sandy loam, 0 to 3% slopes. The soils have generally been described to be well drained with very low runoff class. The majority of the soils have been described to have moderate erosion hazards. (Reference: taken from "Soils, Geology and Geologic Hazard Evaluation" prepared by Entech Engineering, October 2020)

The entire site generally drains north-south at approximate slopes of 1%-3%. The total disturbance area is shown on the Grading and Erosion Control Plan and totals nearly the entire site of 5.05 ac. No wetlands are currently present on site. No springs, landscape irrigation return flows or construction dewatering is anticipated within the limits of construction of this site. Should any of the above items occur unexpectedly, BMPs shall be implemented immediately. The local regulatory agency shall be notified for approval of the BMPs and methods.

Falcon what? Creek?

• **RECEIVING WATERS**

Name of Receiving Water(s)	Falcon
Size/Type/Location of Outfall(s)	Proposed 24" RCP storm outfall from the on-site storm system into existing EDB to the south
Discuss discharge connection to Municipal system (include system name, location, and ultimate receiving water(s):	Existing EDB with outfall location directly into ditch along Meridian Road within the Falcon Basin and ultimately to (Fountain Creek)

• **PROPOSED CONSTRUCTION ACTIVITY**

Proposed construction activities within this project include grading of the proposed private roadway, overlot grading for lots and utility/road installation. See "Final Stabilization and Long term Storm-water Management" section below for final stabilization activities.

• **PROPOSED SEQUENCE OF ACTIVITY/CONSTRUCTION TIMING**

Proposed construction activities within this project include grading and utility/road construction for the proposed commercial subdivision. Sequence of activities will be based upon site contractor timing and scheduling. Upon site contractor selection, contractor to include sequence of activities schedule in the section provided in the Appendix of this report. A standard sequence of events typically includes the following:

- 1) Install perimeter, interior & exterior BMPs (Immediately upon plan approval/permitting – Late Spring 2022) – **Initial Phase**
- 2) Clear and grub site for proposed lots and roadways (After installation of perimeter BMPs - Late Spring 2022) – **Initial Phase**
- 3) Excavation & installation of utilities (Summer 2022) – **Interim Phase**
- 4) Curb/Gutter, paving, installation of perimeter sidewalks and ped-ramps (Summer 2022) – **Interim Phase**
- 5) No vertical Building construction included with this development.



The anticipated start and completion time period for site grading operations is to start in late Spring 2022 with site final site stabilization by Late Summer 2022.

- **EROSION AND SEDIMENT CONTROL**

Erosion control measures shall be implemented in a manner that will protect properties and public facilities from the adverse effects of erosion and sedimentation as a result of construction and earthwork activities. In order to prevent a net increase of sediment load, Best Management Practices will be implemented during the construction life of this project. A silt fence will be installed per the approved grading and erosion control plan in order to protect undisturbed areas. All roads will be inspected to ensure that sediment from on-site construction activity is not being discharged with the stormwater. Roadways shall be swept as needed for controlling tracking of mud onto public roadways. Vehicle tracking control pads will aid in minimizing soil tracking onto roadways. All disturbed areas, not sodded, will be reseeded with a native seed mix and watered until a mature stand is established. All areas disturbed will be protected with silt fence, diversion swales and temporary sediment traps (as needed basis only) until such time as the site has been revegetated. Vegetation and vegetated buffers shall be preserved as much as possible. Wherever feasible, vegetated buffers shall be maintained free from vehicle/equipment parking, storage, stockpiles, or other impacts.

- **DEVELOPMENT AREA/AREAS AND VOLUME STATEMENT**

Total Platted Site Area	<u>5.048</u> Acres
Initial Site area to be disturbed	<u>4.4</u> Acres for overlot/roadway const.
Percent disturbance	<u>87.2</u> %

The total volume of earthwork cut/fill operations is more than 500 CY.

- **SOILS INFORMATION**

The average soil condition reflects Hydrologic Group "A" (Type 19 – Columbine gravelly sandy loam), as determined by the "Soil Survey of El Paso County Area," prepared by the Soil Conservation



Service. The soils have generally been described to be well drained with very low runoff class. The majority of the soils have been described to have moderate erosion hazards but may be controlled by vegetation. Permissible velocities of 4 to 7 ft/sec. allowed with re-established vegetation. Based upon the current proposed development of this site, the following 100-year runoff coefficients would be realized:

Existing site runoff coefficient =	= <u>.35</u>
Developed site runoff coefficient	= <u>.50</u> landscape / seeded areas
Percent disturbance	= <u>.90</u> driveway / paved areas

- **EXISTING SITE CONDITIONS**

This property lies within the Falcon Drainage Basin. The existing drainage patterns generally run in a southerly direction directly into the existing adjacent detention facility. As stated in the approved “Final Drainage Report Addendum No. 2 Bent Grass Residential Filing No. 1 for Bent Grass East Commercial Filing No. 3” this existing detention facility was designed to account for this proposed development.

This site is currently vegetated with native grasses (approximately 85% ground cover) as determined visually during site visit. Existing slopes range from approximately 1 to 3 percent. Reference the Site Description portion of this report for further site conditions.

SITE MAP

With approval of this report is the approved grading, erosion and stormwater quality control plan for the subject property which will serve as the SWMP site map. This document contains site specific grading and erosion control BMP measures as required and approved by the El Paso County. Limits of disturbance, areas of cuts/fills, proposed stockpile areas, areas used for storage of materials, equipment, soil, or waste, batch plants, minimum and maximum cut/fill slopes, existing limits of significant vegetation, locations of springs, streams, and/or wetlands, and existing facilities (including but not limited to: misc. structures, gas main, electric and telecom vaults and fences) will be represented on this plan. The site map will depict locations of specific interim and ultimate stormwater management BMPs throughout the lifetime of the project. Erosion control cost assurances must be posted to the county in the amount listed on Financial



Assurance Estimate Form. The site map/grading plan shall be amended to include any additional interim or phased BMPs over and above measures included on the site map, as required by contractor's construction schedule. All construction BMP details will be included in the appendix of this report. Detail sheets include installation and maintenance requirements. Also reference "Drainage Criteria Manual, Volume 2 Stormwater Quality Policies, Procedure, and Best Management Practices" and the El Paso County ECM for additional information and guidance regarding construction BMPs.

STORMWATER MANAGEMENT

• QUALIFIED STORMWATER MANAGER

The Qualified Stormwater Manager can be an individual(s), position, or title – this entity is responsible for developing, implementing, maintaining, and revising the SWMP. The Qualified Stormwater Manager is the contact for all SWMP related issues and is the entity responsible for its accuracy, completeness, and implementation. Therefore, the Qualified Stormwater Manager should be a person with authority to adequately manage and direct day to day stormwater quality management activities on the subject site. Reference the Appendix of this report for the SWMP permit application which names the individual/entity applying for the permit and naming the Qualified Stormwater Manager of the SWMP. This individual will be sufficiently qualified for these duties per the ECM Appendix I.5.2.A.

• POTENTIAL POLLUTANT SOURCES

Potential pollutant sources which shall be evaluated for potential to contribute pollutants to stormwater discharge from the subject site may include the following:

- Disturbed and stored soils
- Vehicle tracking of sediments
- Management of contaminated soils
- Loading and unloading operations
- Outdoor storage activities (building materials, utility piping and appurtenances, etc.)
- Vehicle and equipment maintenance and fueling
- Significant dust or particulate generating processes
- On-site waste management practices (waste piles, liquid wastes, dumpsters)

- Concrete truck/equipment washing, including the concrete truck chute associated fixtures and equipment
- Non-industrial waste sources such as worker trash and portable toilets
- Other areas or procedures where potential spills can occur.

The location and description of these areas are shown on the attached SWMP Site Map.

- **BMPS FOR POLLUTANT PREVENTION**

The following are common practices to mitigate potential pollutants:

Structural Measures

- Sanitary facilities shall be placed at a minimum of 10' from any curblineline and 50' from any inlet. They will be secured on all four corners to prevent overturning, cleaned on a weekly basis and inspected daily for spills. If not feasible for the project, use of a secondary containment shall be implemented.
- Equipment loading/unloading, fueling and Maintenance Services – a designated loading/unloading and fueling area will be established to contain any spill resulting from loading/unloading, fueling, maintenance, or repair of equipment. Contractors will be responsible for containment, cleanup, and disposal of any leak or spill in this designated area and any costs associated with the cleanup and disposal.
- Concrete washout area will be established on site for all concrete truck/equipment washing. Contractor responsible for cleanup and maintenance of this area.
- Outdoor storage activities – a designated storage area for all building materials, utility piping and appurtenances will be established and maintained by the contractors. Contractors responsible for all cleanup and containment of trash/debris in this area.
- Material stockpiles (soils, soil amendments, debris/trash piles) – All construction trash and debris will be deposited in the dumpster. Dumpster inspected daily for leaks and capacity. Dumpster emptied on a weekly basis or when capacity exceeds the top of the dumpster.

Non-Structural Measures

- Chemical products shall be protected from precipitation, free from ground contact, and stored properly to prevent damage from equipment or vehicles.

- Wind erosion shall be controlled by sprinkling the site roadways with water and/or temporary stabilizing stockpiles by spraying with water from water truck. Each dump truck hauling material from the site will be required to be covered with a tarpaulin.
- Sediment and Migration of Sediment – Sweeping operations will take place as needed to keep roadways maintained. The perimeter of the site will be evaluated for any potential impact resulting from trucking operations or sediment migration from the site. Vehicle tracking controls will be placed and daily maintained at each entry/exit of site. BMP devices such as straw bale inlet protection and rock socks will be placed to protect storm system inlets should any roadway tracking or sediment migration occur.
- Snow removal and/or stockpiling will be considered prior to placement at the site. Snow stockpiles must be kept away from any stormwater conveyance system (i.e., inlets, ponds, outfall locations, roadway surfaces, etc.)

- **BMP SELECTION**

Selection of the appropriate BMP will limit the source of the pollutant. Guidance for the selection process can be found by referencing the City of Colorado Springs/El Paso County “Drainage Criteria Manual Volume 2”.

During grading construction activity for the subject site, silt fence will be installed per the approved plan in order to protect undisturbed areas. Check dams will be installed along all permanent and temporary sideroad swales to minimize erosion in areas of concentrated stormwater. Vehicle tracking control pads will be installed at all access points to the property. Regular maintenance and inspection of these facilities will be necessary throughout driveway construction and until vegetation is reestablished to ensure proper function of the temporary sediment basin outlet structures.

- **MATERIAL HANDLING & SPILL PREVENTION**

Where materials can impact stormwater runoff, existing and planned practices that reduce the potential for pollution must be included in a material handling/spill prevention plan, to be provided by the contractor. Material handling/Spill prevention plans shall include

- Notification procedures to be used in the event of an accident
- Instruction for clean-up procedures, and identification of a spill kit location

- Provisions for absorbents to be made available for use in fuel areas, and for containers to be available for used absorbents
- Procedures for properly washing out concrete truck chutes and other equipment in a manner and location so that the materials and wash water can not discharge from the site and never into a storm sewer system or stream.
- Procedures for properly handling materials and cleanup, identification of material storage areas and associated BMPs such as silt fencing and straw waddles for containment with no discharge from the site will be provided to the Contractor.

- **CONCRETE/ASPHALT BATCH PLANTS**

Where applicable, the SWMP must be amended by the contractor to describe and locate on the Site Map all practices used to control stormwater pollution from dedicated asphalt or concrete batch plants. However, no batch plants are planned for this site.

- **WASTE MANAGEMENT AND DISPOSAL INCLUDING CONCRETE WASHOUT**

Where applicable, the SWMP must be amended by the contractor to describe and locate on the Site Map all practices implemented at the site to control stormwater pollution from all construction site wastes (liquid and solid) including concrete washout activities. The concrete washout area will be located by the contractor and marked-up on the SWMP map kept on-site. Construction site waste area will also be designated by the Contractor and documented on the SWMP map. Procedures for material handling/spill prevention provided as described above.

- **DOCUMENTING SELECTED BMPS**

As discussed in the SITE MAP section of this report, documentation of the selected BMPs will be included on the site map / overlot grading plan included in this report. The site map/overlot grading plan shall be amended to include any additional interim or phased BMPs over and above measures included on the site map, as required by contractor's construction schedule.

- **NON-STORMWATER DISCHARGES**

The SWMP permit covers only discharges composed entirely of stormwater and does not include the following: fire fighting activities, landscape irrigation return-flow and uncontaminated springs. However, none of the above non-stormwater discharges are anticipated for this site.

- **STORMWATER DEWATERING**

The discharge of pumped water, ONLY from excavations, ponds, depressions, etc., to surface waters or to a municipal separate storm-sewer system is allowed by the Stormwater Dewatering Permit as long as the dewatering activity and associated BMPs are identified in the SWMP (including location of activity), and the BMPs are implemented in accordance with the SWMP. Where applicable, all stormwater and groundwater dewatering practices implemented to control stormwater pollution for dewatering must be amended in the SWMP and Site Map by the contractor.

- **REVISING BMPs AND THE SWMP**

The implemented BMPs will need to be modified and maintained regularly to adapt to changing site conditions and to ensure that all potential stormwater pollutants are properly managed. The BMPs and pollutant sources must be reviewed on an ongoing basis by the Qualified Stormwater Manager as assigned by the Permit. With any construction project, special attention must be paid to construction phasing and therefore revisions to the SWMP to include any additional or modification to the BMPs and SWMP report. The SWMP must be modified or amended to accurately reflect the field conditions. Examples include - but are not limited to – removal of BMPs, identification of new potential pollutant procedures, and changes to information provided in the site map/overlot grading plan. SWMP revisions must be made prior to changes in site conditions. The SWMP should be viewed as a “living document” throughout the lifetime of the project.

**FINAL STABILIZATION AND
LONG-TERM STORMWATER MANAGEMENT**

Note that the contractor will be responsible for any re-excavation of sediment and debris that collects in the existing pond, required to ensure that the pond meets the design grades following construction. The storm lines shall also be cleaned and free of sediment once the site becomes stabilized.

Permanent stabilization of the site includes seeding and mulching the site. Seeding and mulching consists of loosening soil, applying topsoil (if permanent seeding) and drill seeding disturbed areas with grasses and crimping in straw mulch to provide immediate protection from raindrop and wind erosion. As the grass cover becomes established, provide long term stabilization of exposed soils.

Once the construction activity ceases permanently, the area will be stabilized with permanent seed and mulch within 14 days. All areas that will not be impacted by construction of buildings will be seeded and landscaped as feasible. After seeding, each area will be mulched with straw. The straw mulch is to be tacked into place by a disc with blades set nearly straight. Topsoil stockpiles will be stabilized with

temporary seed and mulch. Areas of the site that are to be paved will be temporarily stabilized until asphalt is applied. Rough cut street controls will be utilized in these areas to control erosion by minimizing concentration of flow and reducing runoff velocity.

The temporary perimeter controls (silt fence or equivalent) will not be removed until all construction activities at the site are complete and soils have been stabilized and final stabilization has been achieved. Upon completion of construction activities, the site shall be inspected to ensure all equipment, waste materials, and debris have been removed. All other BMPs or other control practices and measure that are to remain after completion of construction will be inspected to ensure they are properly functioning. Final stabilization is reached when all soil disturbing activities at the site have been completed and uniform vegetative cover has been established with a density of at least 70% of pre-disturbance levels. For purposes of the SWMP, establishment of a vegetative cover capable of providing erosion control equivalent to the pre-existing conditions at the site can be considered final stabilized.

Long term stormwater quality management and providing water quality capture volume (WQCV) is required for this site. As mentioned earlier, the existing off-site detention facility was designed and constructed to handle the required WQCV for the impervious area within this property.

INSPECTION AND MAINTENANCE PROCEDURES

All drainage facilities will be monitored using the enclosed "Monitoring and Maintenance Inspection Record" checklist (Appendix II).

- **SWMP QUALIFIED STORMWATER MANAGER INSPECTION PROCEDURES & SCHEDULES**

The Qualified Stormwater Manager shall adhere to the following inspection procedures during the development of the site:

1. Make thorough inspection of the stormwater management system at least every 14 days.
2. Make thorough inspection of the stormwater management system within 24 hrs of each precipitation or snow melt event that creates runoff.
3. If any system deficiencies are noted, corrective actions must begin immediately. Documentation of inspection must be available if requested.
4. Records of the site inspections or facility replacement modifications must be kept at the site within this report.

Item 26. Discuss BMPs owned or operated by another entity, or lack thereof.

5. 30-day inspections must take place on this site where construction activity is complete, but vegetative cover is still being established.

In this report's appendix, a site inspection form has been included for use by the Inspector. Upon completion of this form, the document is to be kept in the provided folder also in the rear of this report.

- **BMP MAINTENANCE / REPLACEMENT & FAILED BMPs**

The Stormwater Construction Permit requires that all erosion and sediment control practices and other protective measures identified in the SWMP be maintained in effective and operation condition. A preventative maintenance program should be in place to prevent BMP breakdowns and failures by proactively maintaining or replacing BMPs and equipment. The inspections process should also include procedures to ensure that BMPs are replaced or new BMPs added to adequately manage the pollutant sources at the site. This procedure is part of the ongoing process of revising the BMPs and SWMP as previously discussed, and any changes shall be recorded in the SWMP.

- **RECORD KEEPING AND DOCUMENTING INSPECTIONS**

The following items must be documented by the Qualified Stormwater Manager as part of the site inspections and kept in a notebook located on-site with the approved grading and erosion control plans:

- Inspection date
- Name(s) and title(s) and signature(s) of personnel making inspection
- Location(s) of discharges of sediment or other pollutants from site
- Location(s) of BMPs that need to be maintained
- Location(s) of BMPs that fail to operate as designed or proved inadequate in a particular location
- Location(s) where additional BMPs are needed that were not in place at time of inspection
- Deviations from the minimum inspection schedule
- Descriptions of corrective action for items above including dates and measures taken to prevent future violations
- Signed statement of compliance added to the report after correction action has been taken

EROSION CONTROL COST OPINION

ITEM	DESCRIPTION	QUANTITY	UNIT COST	COST
1.	Permanent E.C Blanket	140 SY	\$6.00/SY	\$ 840.00
2.	Vehicle Tracking Control	2 EACH	\$2,453/EA	\$ 4,906.00
3.	Silt Fence	700 LF	\$2.60/LF	\$ 1,820.00
4.	Temporary Seeding	3.8 AC.	\$650/AC.	\$ 2,470.00
5.	Temporary Mulch	3.8 AC.	\$777/AC.	\$ 2,952.60
6.	Erosion Bales	6 EACH	\$26.00/EA	\$ 156.00
7.	Inlet Protection	2 EACH	\$173.00/EA	\$ 346.00
8.	Concrete Washout	1 EACH	\$932.00/EA	\$ 932.00
SUB TOTAL				\$ 14,422.60
Maintenance (35% of construction BMPs)				\$ 5,047.91
TOTAL				<u>\$ 19,470.51</u>

Classic Consulting Engineers & Surveyors cannot and does not guarantee that the construction cost will not vary from these opinions of probable construction costs. These opinions represent our best judgment as design professionals familiar with the construction industry and this development in particular.

PREPARED BY:

Classic Consulting Engineers & Surveyors, LLC



Marc A. Whorton, P.E.
Project Manager

maw/2177.64/Reports/SWMP Report Vol2.doc



VICINITY MAP



Bent Grass East Commercial Filing 3 - Vicinity Map

DATE: 10/30/2020
 ISSUED FOR: '
 DRAWN BY: JS
 DWG. REF.:

SCALE: 1" = 250'
 DWG. #:

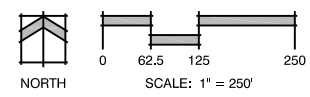

N.E.S. Inc.
 619 N. Cascade Ave.
 Suite 200
 Colorado Springs, CO 80903
 Tel. 719.471.0073
 Fax 719.471.0267
 www.nescolorado.com

COPY OF PERMIT APPLICATION

General permit application for stormwater discharges associated with construction activity.





STATE OF COLORADO

COLORADO DEPARTMENT OF PUBLIC HEALTH AND ENVIRONMENT

Water Quality Control Division

CDPS GENERAL PERMIT
STORMWATER DISCHARGES ASSOCIATED WITH
CONSTRUCTION ACTIVITY
AUTHORIZATION TO DISCHARGE UNDER THE
COLORADO DISCHARGE PERMIT SYSTEM (CDPS)

In compliance with the provisions of the Colorado Water Quality Control Act, (25-8-101 et seq., CRS, 1973 as amended) and the Federal Water Pollution Control Act, as amended (33 U.S.C. 1251 et seq.; the "Act"), this permit authorizes the discharge of stormwater associated with construction activities (and specific allowable non-stormwater discharges in accordance with Part I.A.1. of the permit) certified under this permit, from those locations specified throughout the State of Colorado to specified waters of the State.

Such discharges shall be in accordance with the conditions of this permit. This permit specifically authorizes the facility listed on the certification to discharge in accordance with permit requirements and conditions set forth in Parts I and II hereof. All discharges authorized herein shall be consistent with the terms and conditions of this permit.

This permit becomes effective on April 1, 2019, and shall expire at midnight March 31, 2024.

Issued and signed this 1st day of November 2018.

COLORADO DEPARTMENT OF PUBLIC HEALTH AND ENVIRONMENT

Ellen Howard Kutzer, Permits Section Manager
Water Quality Control Division

Permit History

Originally signed and issued October 31, 2018; effective April 1, 2019.

CONTRACTOR SEQUENCE OF ACTIVITIES

Table CP-1. Typical Phased BMP Installation for Construction Projects

Project Phase	BMPs
Pre-disturbance, Site Access	<ul style="list-style-type: none"> ▪ Install sediment controls downgradient of access point (on paved streets this may consist of inlet protection). ▪ Establish vehicle tracking control at entrances to paved streets. Fence as needed. ▪ Use construction fencing to define the boundaries of the project and limit access to areas of the site that are not to be disturbed. <p>Note: it may be necessary to protect inlets in the general vicinity of the site, even if not downgradient, if there is a possibility that sediment tracked from the site could contribute to the inlets.</p>
Site Clearing and Grubbing	<ul style="list-style-type: none"> ▪ Install perimeter controls as needed on downgradient perimeter of site (silt fence, wattles, etc). ▪ Limit disturbance to those areas planned for disturbance and protect undisturbed areas within the site (construction fence, flagging, etc). ▪ Preserve vegetative buffer at site perimeter. ▪ Create stabilized staging area. ▪ Locate portable toilets on flat surfaces away from drainage paths. Stake in areas susceptible to high winds. ▪ Construct concrete washout area and provide signage. ▪ Establish waste disposal areas. ▪ Install sediment basins. ▪ Create dirt perimeter berms and/or brush barriers during grubbing and clearing. ▪ Separate and stockpile topsoil, leave roughened and/or cover. ▪ Protect stockpiles with perimeter control BMPs. Stockpiles should be located away from drainage paths and should be accessed from the upgradient side so that perimeter controls can remain in place on the downgradient side. Use erosion control blankets, temporary seeding, and/or mulch for stockpiles that will be inactive for an extended period. ▪ Leave disturbed area of site in a roughened condition to limit erosion. Consider temporary revegetation for areas of the site that have been disturbed but that will be inactive for an extended period. ▪ Water to minimize dust but not to the point that watering creates runoff.

Project Phase	BMPs
Utility And Infrastructure Installation	<p>In Addition to the Above BMPs:</p> <ul style="list-style-type: none"> ▪ Close trench as soon as possible (generally at the end of the day). ▪ Use rough-cut street control or apply road base for streets that will not be promptly paved. ▪ Provide inlet protection as streets are paved and inlets are constructed. ▪ Protect and repair BMPs, as necessary. ▪ Perform street sweeping as needed.
Building Construction	<p>In Addition to the Above BMPs:</p> <ul style="list-style-type: none"> ▪ Implement materials management and good housekeeping practices for home building activities. ▪ Use perimeter controls for temporary stockpiles from foundation excavations. ▪ For lots adjacent to streets, lot-line perimeter controls may be necessary at the back of curb.
Final Grading	<p>In Addition to the Above BMPs:</p> <ul style="list-style-type: none"> ▪ Remove excess or waste materials. ▪ Remove stored materials.
Final Stabilization	<p>In Addition to the Above BMPs:</p> <ul style="list-style-type: none"> ▪ Seed and mulch/tackify. ▪ Seed and install blankets on steep slopes. ▪ Remove all temporary BMPs when site has reached final stabilization.

**COLORADO DISCHARGE PERMIT
SYSTEM (CDPS) CHECKLIST
Operation & Maintenance Inspection Record**

The following inspection records are to be used at each bi-monthly stormwater management system inspection and after any precipitation or snowmelt event that causes surface runoff. As a result of these inspections, the SWMP may need to be revised. The inspection records and revised SWMP shall be made available to the division upon request. If the construction activity lasts more than 12 months, a copy of the inspection records and revised SWMP shall be sent to the division by May 1 of each year covering April 1 to March 31.



CONSTRUCTION STORMWATER SITE INSPECTION REPORT

Facility Name		Permittee					
Date of Inspection		Weather Conditions					
Permit Certification #		Disturbed Acreage					
Phase of Construction		Inspector Title					
Inspector Name							
Is the above inspector a qualified stormwater manager? (permittee is responsible for ensuring that the inspector is a qualified stormwater manager)			<table border="1" style="width: 100%; border-collapse: collapse;"> <tr> <td style="width: 50%; text-align: center;">YES</td> <td style="width: 50%; text-align: center;">NO</td> </tr> <tr> <td style="text-align: center;"><input type="checkbox"/></td> <td style="text-align: center;"><input type="checkbox"/></td> </tr> </table>	YES	NO	<input type="checkbox"/>	<input type="checkbox"/>
YES	NO						
<input type="checkbox"/>	<input type="checkbox"/>						

INSPECTION FREQUENCY					
Check the box that describes the minimum inspection frequency utilized when conducting each inspection					
At least one inspection every 7 calendar days	<input type="checkbox"/>				
At least one inspection every 14 calendar days, with post-storm event inspections conducted within 24 hours after the end of any precipitation or snowmelt event that causes surface erosions	<input type="checkbox"/>				
<ul style="list-style-type: none"> • This is this a post-storm event inspection. Event Date: _____ 	<input type="checkbox"/>				
Reduced inspection frequency - Include site conditions that warrant reduced inspection frequency	<input type="checkbox"/>				
<ul style="list-style-type: none"> • Post-storm inspections at temporarily idle sites 	<input type="checkbox"/>				
<ul style="list-style-type: none"> • Inspections at completed sites/area 	<input type="checkbox"/>				
<ul style="list-style-type: none"> • Winter conditions exclusion 	<input type="checkbox"/>				
Have there been any deviations from the minimum inspection schedule? If yes, describe below.	<table border="1" style="width: 100%; border-collapse: collapse;"> <tr> <td style="width: 50%; text-align: center;">YES</td> <td style="width: 50%; text-align: center;">NO</td> </tr> <tr> <td style="text-align: center;"><input type="checkbox"/></td> <td style="text-align: center;"><input type="checkbox"/></td> </tr> </table>	YES	NO	<input type="checkbox"/>	<input type="checkbox"/>
YES	NO				
<input type="checkbox"/>	<input type="checkbox"/>				

INSPECTION REQUIREMENTS*
i. Visually verify all implemented control measures are in effective operational condition and are working as designed in the specifications
ii. Determine if there are new potential sources of pollutants
iii. Assess the adequacy of control measures at the site to identify areas requiring new or modified control measures to minimize pollutant discharges
iv. Identify all areas of non-compliance with the permit requirements, and if necessary, implement corrective action
*Use the attached Control Measures Requiring Routine Maintenance and Inadequate Control Measures Requiring Corrective Action forms to document results of this assessment that trigger either maintenance or corrective actions

AREAS TO BE INSPECTED			
Is there evidence of, or the potential for, pollutants leaving the construction site boundaries, entering the stormwater drainage system or discharging to state waters at the following locations?			
	NO	YES	If "YES" describe discharge or potential for discharge below. Document related maintenance, inadequate control measures and corrective actions Inadequate Control Measures Requiring Corrective Action form
Construction site perimeter	<input type="checkbox"/>	<input type="checkbox"/>	
All disturbed areas	<input type="checkbox"/>	<input type="checkbox"/>	
Designated haul routes	<input type="checkbox"/>	<input type="checkbox"/>	
Material and waste storage areas exposed to precipitation	<input type="checkbox"/>	<input type="checkbox"/>	
Locations where stormwater has the potential to discharge offsite	<input type="checkbox"/>	<input type="checkbox"/>	
Locations where vehicles exit the site	<input type="checkbox"/>	<input type="checkbox"/>	
Other: _____	<input type="checkbox"/>	<input type="checkbox"/>	

REPORTING REQUIREMENTS

The permittee shall report the following circumstances orally within twenty-four (24) hours from the time the permittee becomes aware of the circumstances, and shall mail to the division a written report containing the information requested within five (5) working days after becoming aware of the following circumstances. The division may waive the written report required if the oral report has been received within 24 hours.

All Noncompliance Requiring 24-Hour Notification per Part II.L.6 of the Permit		
a. Endangerment to Health or the Environment Circumstances leading to any noncompliance which may endanger health or the environment regardless of the cause of the incident (See Part II.L.6.a of the Permit) <i>This category would primarily result from the discharge of pollutants in violation of the permit</i>		
b. Numeric Effluent Limit Violations <ul style="list-style-type: none"> o Circumstances leading to any unanticipated bypass which exceeds any effluent limitations (See Part II.L.6.b of the Permit) o Circumstances leading to any upset which causes an exceedance of any effluent limitation (See Part II.L.6.c of the Permit) o Daily maximum violations (See Part II.L.6.d of the Permit) <i>Numeric effluent limits are very uncommon in certifications under the COR400000 general permit. This category of noncompliance only applies if numeric effluent limits are included in a permit certification.</i>		

Has there been an incident of noncompliance requiring 24-hour notification?	NO	YES	
	<input type="checkbox"/>	<input type="checkbox"/>	If "YES" document below

Date and Time of Incident	Location	Description of Noncompliance	Description of Corrective Action	Date and Time of 24 Hour Oral Notification	Date of 5 Day Written Notification *

*Attach copy of 5 day written notification to report. Indicate if written notification was waived, including the name of the division personnel who granted waiver.

After adequate corrective action(s) and maintenance have been taken, or where a report does not identify any incidents requiring corrective action or maintenance, the individual(s) designated as the Qualified Stormwater Manager, shall sign and certify the below statement:

"I verify that, to the best of my knowledge and belief, all corrective action and maintenance items identified during the inspection are complete, and the site is currently in compliance with the permit."

Name of Qualified Stormwater Manager

Title of Qualified Stormwater Manager

Signature of Qualified Stormwater Manager

Date

Notes/Comments

**COMPLETED OPERATION AND
MAINTENANCE INSPECTION RECORDS**

STANDARD BMP DETAILS
W/ INSTALLATION AND MAINTENANCE REQUIREMENTS

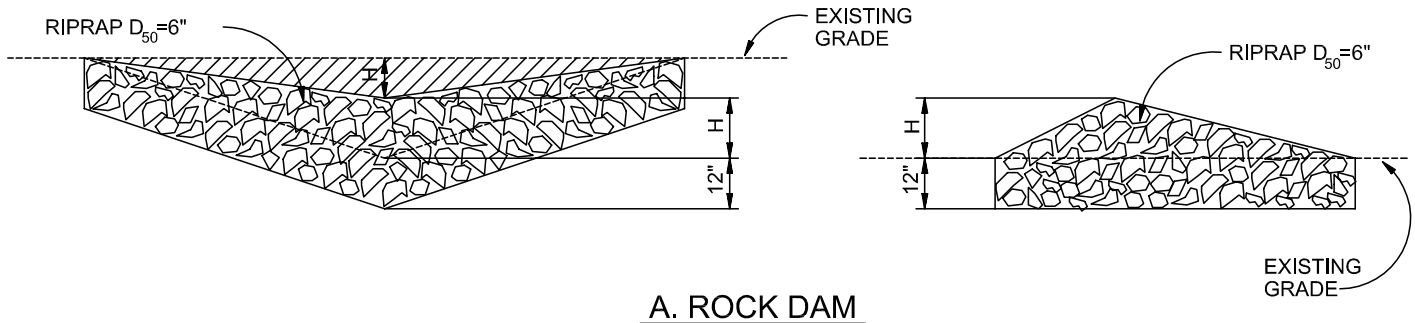

A. ROCK DAM

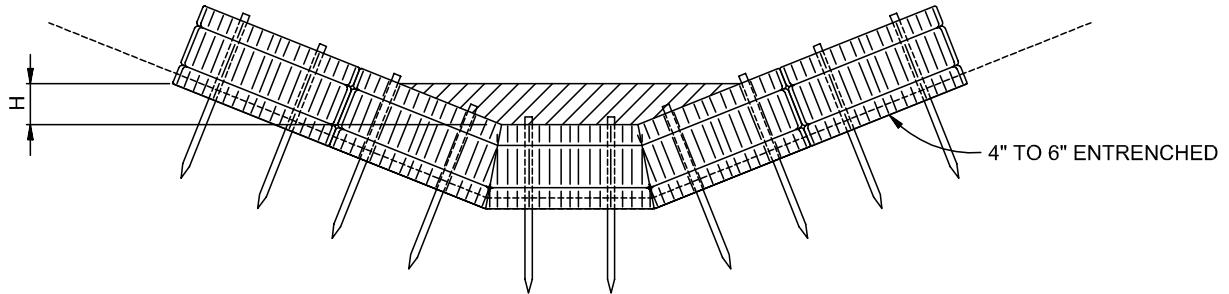

B. STRAW BALE CHECK DAM

(SEE STRAW BALE BARRIER INSTALLATION)

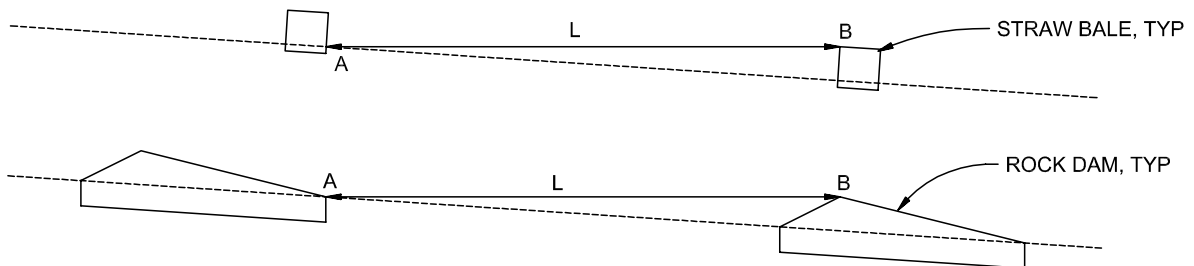

L= THE DISTANCE SUCH THAT POINTS A AND B ARE AT THE SAME ELEVATION.

C. SPACING CHECK DAMS

CHECK DAM

NTS

CHECK DAM NOTES

INSTALLATION REQUIREMENTS

1. STRAW BALES USED AS CHECK DAMS ARE TO MEET THE REQUIREMENTS STATED IN FIGURE SBB-2.
2. THE "H" DIMENSION SHALL BE SELECTED TO PROVIDE WEIR FLOW CONVEYANCE FOR 2-YEAR FLOW OR GREATER.

MAINTENANCE REQUIREMENTS

1. REGULAR INSPECTIONS ARE TO BE MADE OF ALL CHECK DAMS, ESPECIALLY AFTER STORM EVENTS.
2. REPLACE STONE AS NECESSARY TO MAINTAIN THE CORRECT HEIGHT OF THE DAM.
3. ACCUMULATED SEDIMENT AND DEBRIS IS TO BE REMOVED FROM BEHIND THE DAMS AFTER EACH STORM OR WHEN 1/2 OF THE ORIGINAL HEIGHT OF THE DAM IS REACHED.
3. CHECK DAMS ARE TO REMAIN IN PLACE AND OPERATIONAL UNTIL THE DRAINAGE AREA AND CHANNEL ARE PERMANENTLY STABILIZED.
4. WHEN CHECK DAMS ARE REMOVED THE CHANNEL LINING OR VEGETATION IS TO BE RESTORED.

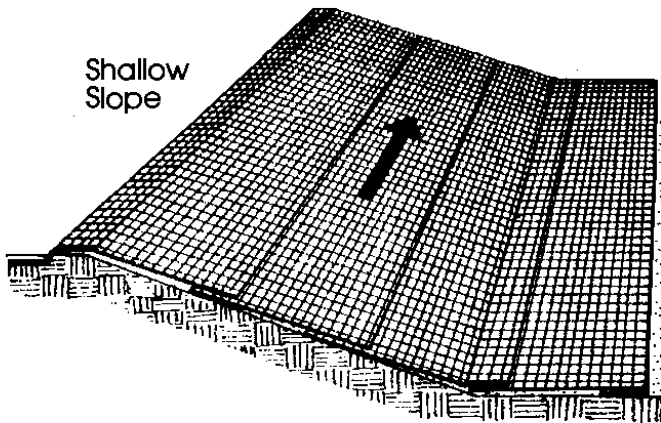

Shallow Slope

On shallow slopes, strips of netting may be applied across the slope.

Where there is a berm at the top of the slope, bring the netting over the berm and anchor it behind the berm.

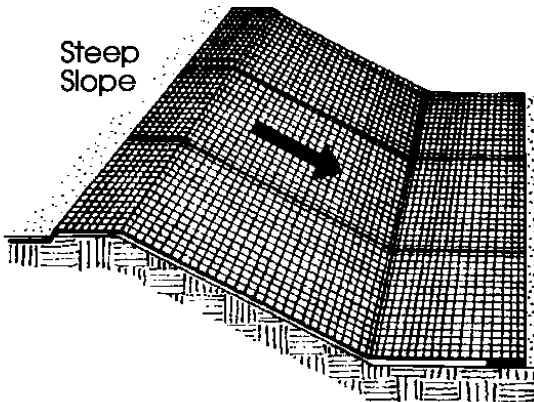

Steep Slope

On steep slopes, apply strips of netting parallel to the direction of flow and anchor securely.

Bring netting down to a level area before terminating the installation. Turn the end under 6" and staple at 12" intervals.

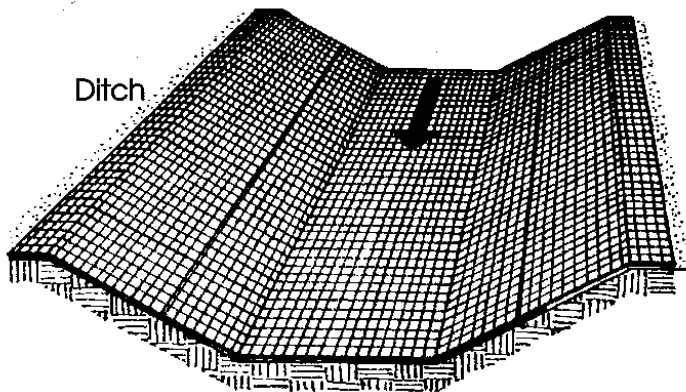
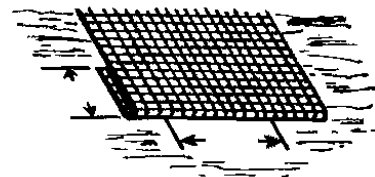

Ditch

In ditches, apply netting parallel to the direction of flow. Use check slots every 15 feet. Do not join strips in the center of the ditch.

From: Virginia Soil and Water Conservation Commission, 1985

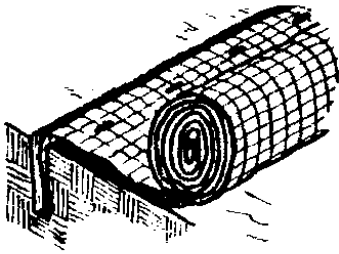

Anchor Slot: Bury the up-channel end of the net in a 6" deep trench. Tamp the soil firmly. Staple at 12" intervals across the net.

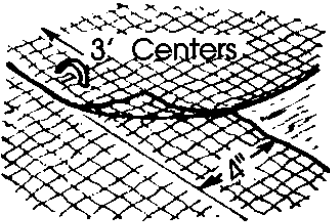

Overlap: Overlap edges of the strips at least 4". Staple every 3 feet down the center of the strip.

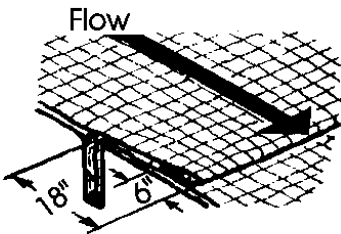
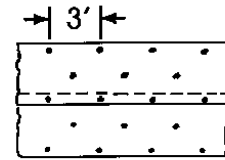

Joining Strips: Insert the new roll of net in a trench, as with the Anchor Slot. Overlap the up-channel end of the previous roll 18" and turn the end under 6". Staple the end of the previous roll just below the anchor slot and at the end at 12" intervals.

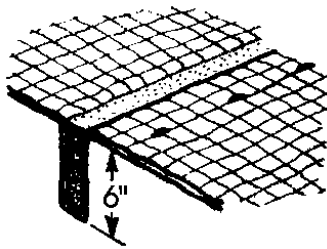

Check Slots: On erodible soils or steep slopes, check slots should be made every 15 feet. Insert a fold of the net into a 6" trench and tamp firmly. Staple at 12" intervals across the net. Lay the net smoothly on the surface of the soil - do not stretch the net, and do not allow wrinkles.

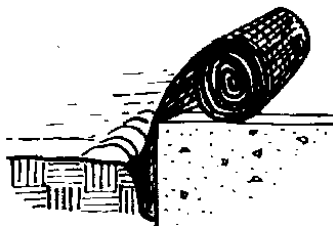

Anchoring Ends At Structures: Place the end of the net in a 6" slot on the up-channel side of the structure. Fill the trench and tamp firmly. Roll the net up the channel. Place staples at 12" intervals along the anchor end of the net.

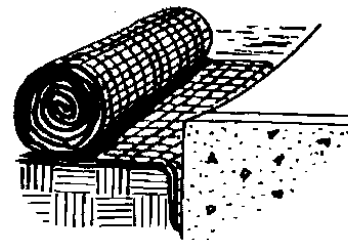

From: Virginia Soil and Water Conservation Commission, 1985

City of Colorado Springs
Storm Water Quality

Figure ECB-2
Erosion Control Blanket
Installation Requirements

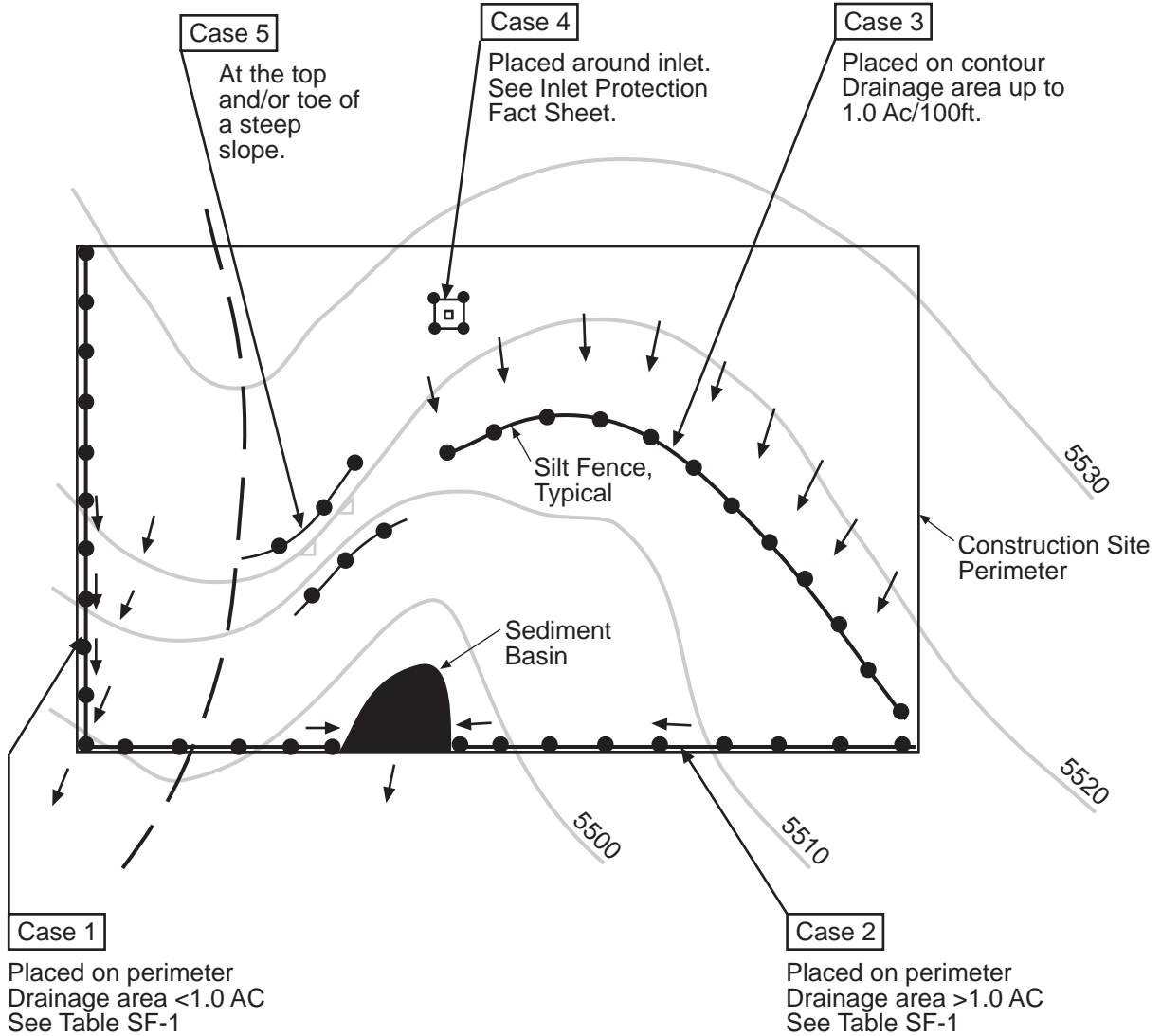

Table SF-1

Silt Fence Used as Perimeter Control	Case 1		Case 2 DA > 1.0 AC
	DA < 0.25 AC	0.25 < DA < 1 AC	
Continuous Grade	OK ⁽¹⁾	OK ⁽¹⁾	OK ⁽¹⁾
Area of Concentrated Flow	OK	NO ⁽²⁾	NO ⁽³⁾

(1) Temporary Swale or Straw Bale Barrier may be used as alternative to a Silt Fence.

(2) Check Dam may also be used as alternative to Silt Fence at low point.

(3) Sediment Basin is required for concentrated flow from drainage areas > 1.0 AC.

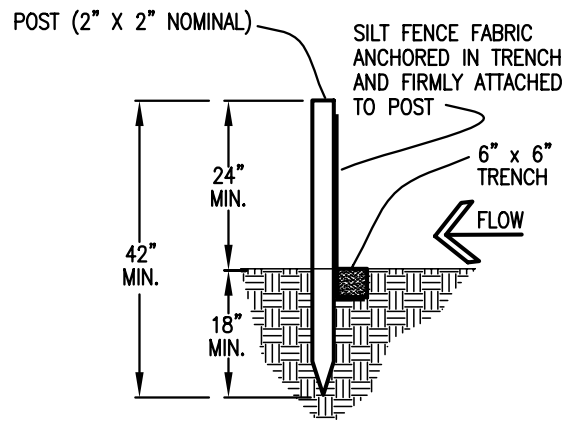
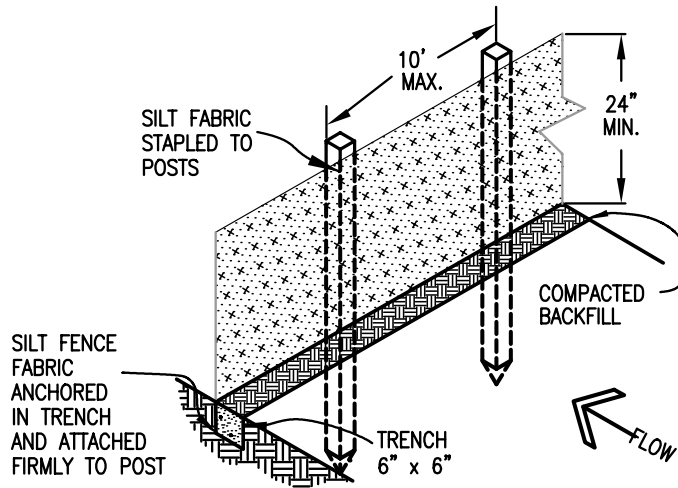

SILT FENCE

SILT FENCE NOTES

INSTALLATION REQUIREMENTS

1. SILT FENCES SHALL BE INSTALLED PRIOR TO ANY LAND DISTURBING ACTIVITIES.
2. WHEN JOINTS ARE NECESSARY, SILT FENCE GEOTEXTILE SHALL BE SPLICED TOGETHER ONLY AT SUPPORT POST AND SECURELY SEALED.
3. METAL POSTS SHALL BE "STUDDED TEE" OR "U" TYPE WITH MINIMUM WEIGHT OF 1.33 POUNDS PER LINEAR FOOT. WOOD POSTS SHALL HAVE A MINIMUM DIAMETER OR CROSS SECTION DIMENSION OF 2 INCHES.
4. THE FILTER MATERIAL SHALL BE FASTENED SECURELY TO METAL OR WOOD POSTS USING WIRE TIES, OR TO WOOD POSTS WITH 3/4" LONG #9 HEAVY-DUTY STAPLES. THE SILT FENCE GEOTEXTILE SHALL NOT BE STAPLED TO EXISTING TREES.
5. WHILE NOT REQUIRED, WIRE MESH FENCE MAY BE USED TO SUPPORT THE GEOTEXTILE. WIRE FENCE SHALL BE FASTENED SECURELY TO THE UPSLOPE SIDE OF THE POSTS USING HEAVY-DUTY WIRE STAPLES AT LEAST 3/4" LONG, TIE WIRES OR HOG RINGS. THE WIRE SHALL EXTEND INTO THE TRENCH A MINIMUM OF 6" AND SHALL NOT EXTEND MORE THAN 3' ABOVE THE ORIGINAL GROUND SURFACE.

6. ALONG THE TOE OF FILLS, INSTALL THE SILT FENCE ALONG A LEVEL CONTOUR AND PROVIDE AN AREA BEHIND THE FENCE FOR RUNOFF TO POND AND SEDIMENT TO SETTLE. A MINIMUM DISTANCE OF 5 FEET FROM THE TOE OF THE FILL IS RECOMMENDED.
7. THE HEIGHT OF THE SILT FENCE FROM THE GROUND SURFACE SHALL BE MINIMUM OF 24 INCHES AND SHALL NOT EXCEED 36 INCHES; HIGHER FENCES MAY INPOUND VOLUMES OF WATER SUFFICIENT TO CAUSE FAILURE OF THE STRUCTURE.

MAINTENANCE REQUIREMENTS

1. CONTRACTOR SHALL INSPECT SILT FENCES IMMEDIATELY AFTER EACH RAINFALL, AT LEAST DAILY DURING PROLONGED RAINFALL, AND WEEKLY DURING PERIODS OF NO RAINFALL. DAMAGED, COLLAPSED, UNENTRENCHED OR INEFFECTIVE SILT FENCES SHALL BE PROMPTLY REPAIRED OR REPLACED.
2. SEDIMENT SHALL BE REMOVED FROM BEHIND SILT FENCE WHEN IT ACCUMULATES TO HALF THE EXPOSED GEOTEXTILE HEIGHT.
3. SILT FENCES SHALL BE REMOVED WHEN ADEQUATE VEGETATIVE COVER IS ATTAINED AS APPROVED BY THE CITY.

Top View of Silt Fence Posts Detail

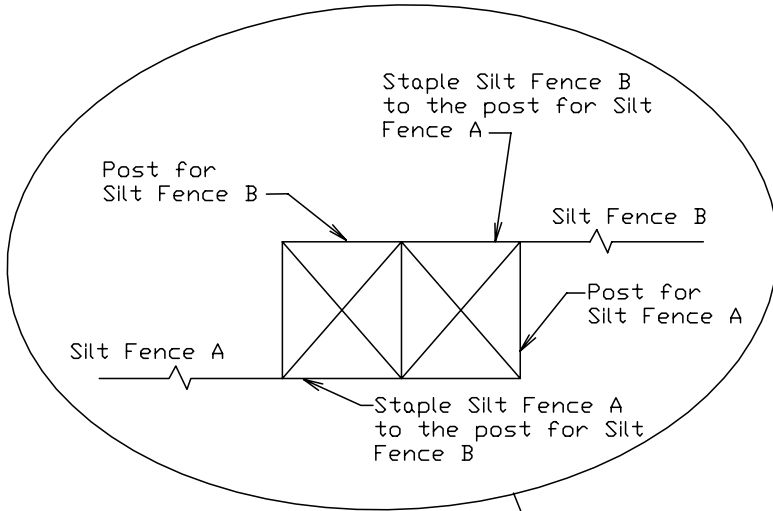

Refer to "Top View of Silt Fence Posts Detail"

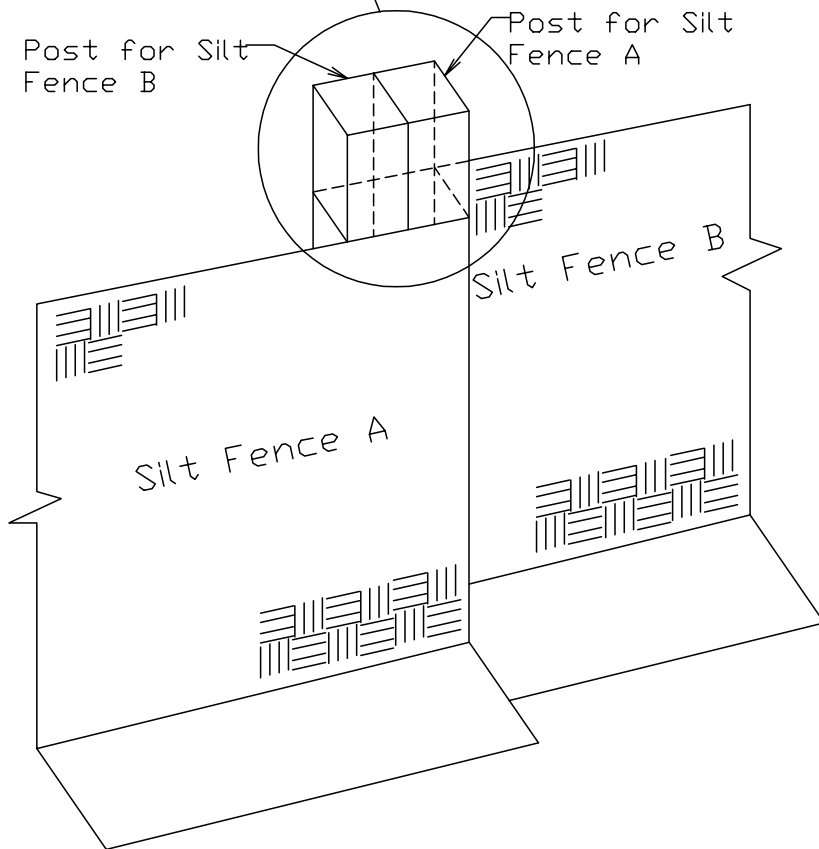

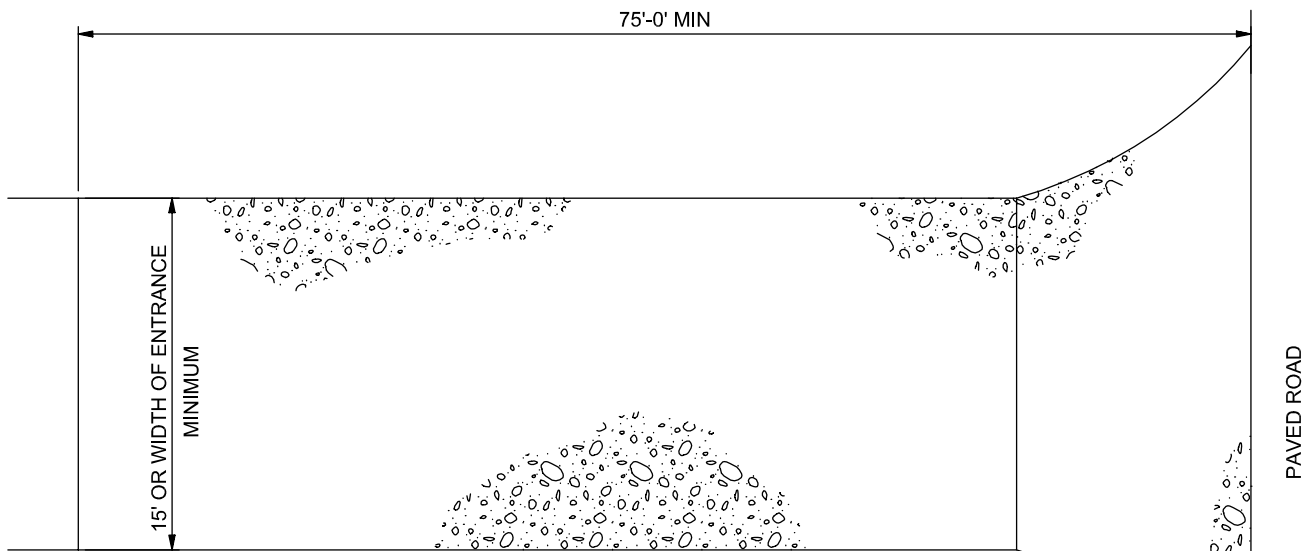

PLAN

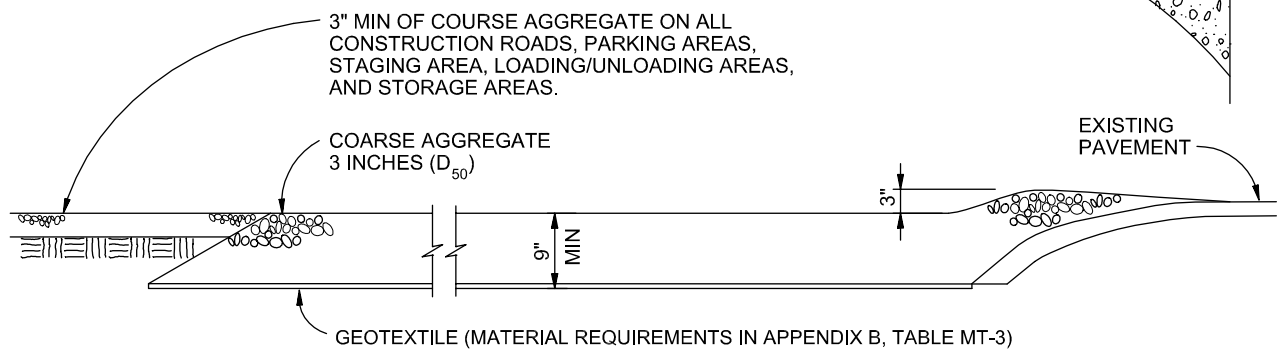

SECTION

VEHICLE TRACKING

NTS

VEHICLE TRACKING NOTES

INSTALLATION REQUIREMENTS

1. ALL ENTRANCES TO THE CONSTRUCTION SITE ARE TO BE STABILIZED PRIOR TO CONSTRUCTION BEGINNING.
2. CONSTRUCTION ENTRANCES ARE TO BE BUILT WITH AN APRON TO ALLOW FOR TURNING TRAFFIC, BUT SHOULD NOT BE BUILT OVER EXISTING PAVEMENT EXCEPT FOR A SLIGHT OVERLAP.
3. AREAS TO BE STABILIZED ARE TO BE PROPERLY GRADED AND COMPACTED PRIOR TO LAYING DOWN GEOTEXTILE AND STONE.
4. CONSTRUCTION ROADS, PARKING AREAS, LOADING/UNLOADING ZONES, STORAGE AREAS, AND STAGING AREAS ARE TO BE STABILIZED.
5. CONSTRUCTION ROADS ARE TO BE BUILT TO CONFORM TO SITE GRADES, BUT SHOULD NOT HAVE SIDE SLOPES OR ROAD GRADES THAT ARE EXCESSIVELY STEEP.

MAINTENANCE REQUIREMENTS

1. REGULAR INSPECTIONS ARE TO BE MADE OF ALL STABILIZED AREAS, ESPECIALLY AFTER STORM EVENTS.
2. STONES ARE TO BE REAPPLIED PERIODICALLY AND WHEN REPAIR IS NECESSARY.
3. SEDIMENT TRACKED ONTO PAVED ROADS IS TO BE REMOVED DAILY BY SHOVELING OR SWEEPING. SEDIMENT IS NOT TO BE WASHED DOWN STORM SEWER DRAINS.
4. STORM SEWER INLET PROTECTION IS TO BE IN PLACE, INSPECTED, AND CLEANED IF NECESSARY.
5. OTHER ASSOCIATED SEDIMENT CONTROL MEASURES ARE TO BE INSPECTED TO ENSURE GOOD WORKING CONDITION.

City of Colorado Springs
Stormwater Quality

Figure VT-2
Vehicle Tracking

Application Examples

CWA MAINTENANCE NOTES

1. INSPECT BMPs EACH WORKDAY, AND MAINTAIN THEM IN EFFECTIVE OPERATING CONDITION. MAINTENANCE OF BMPs SHOULD BE PROACTIVE, NOT REACTIVE. INSPECT BMPs AS SOON AS POSSIBLE (AND ALWAYS WITHIN 24 HOURS) FOLLOWING A STORM THAT CAUSES SURFACE EROSION, AND PERFORM NECESSARY MAINTENANCE.

2. FREQUENT OBSERVATIONS AND MAINTENANCE ARE NECESSARY TO MAINTAIN BMPs IN EFFECTIVE OPERATING CONDITION. INSPECTIONS AND CORRECTIVE MEASURES SHOULD BE DOCUMENTED THOROUGHLY.

3. WHERE BMPs HAVE FAILED, REPAIR OR REPLACEMENT SHOULD BE INITIATED UPON DISCOVERY OF THE FAILURE.

4. THE CWA SHALL BE REPAIRED, CLEANED, OR ENLARGED AS NECESSARY TO MAINTAIN CAPACITY FOR CONCRETE WASTE. CONCRETE MATERIALS, ACCUMULATED IN PIT, SHALL BE REMOVED ONCE THE MATERIALS HAVE REACHED A DEPTH OF 2'.

5. CONCRETE WASHOUT WATER, WASTED PIECES OF CONCRETE AND ALL OTHER DEBRIS IN THE SUBSURFACE PIT SHALL BE TRANSPORTED FROM THE JOB SITE IN A WATER-TIGHT CONTAINER AND DISPOSED OF PROPERLY.

6. THE CWA SHALL REMAIN IN PLACE UNTIL ALL CONCRETE FOR THE PROJECT IS PLACED.

7. WHEN THE CWA IS REMOVED, COVER THE DISTURBED AREA WITH TOP SOIL, SEED AND MULCH OR OTHERWISE STABILIZED IN A MANNER APPROVED BY THE LOCAL JURISDICTION.

(DETAIL ADAPTED FROM DOUGLAS COUNTY, COLORADO AND THE CITY OF PARKER, COLORADO, NOT AVAILABLE IN AUTOCAD).

NOTE: MANY JURISDICTIONS HAVE BMP DETAILS THAT VARY FROM UDFCD STANDARD DETAILS. CONSULT WITH LOCAL JURISDICTIONS AS TO WHICH DETAIL SHOULD BE USED WHEN DIFFERENCES ARE NOTED.

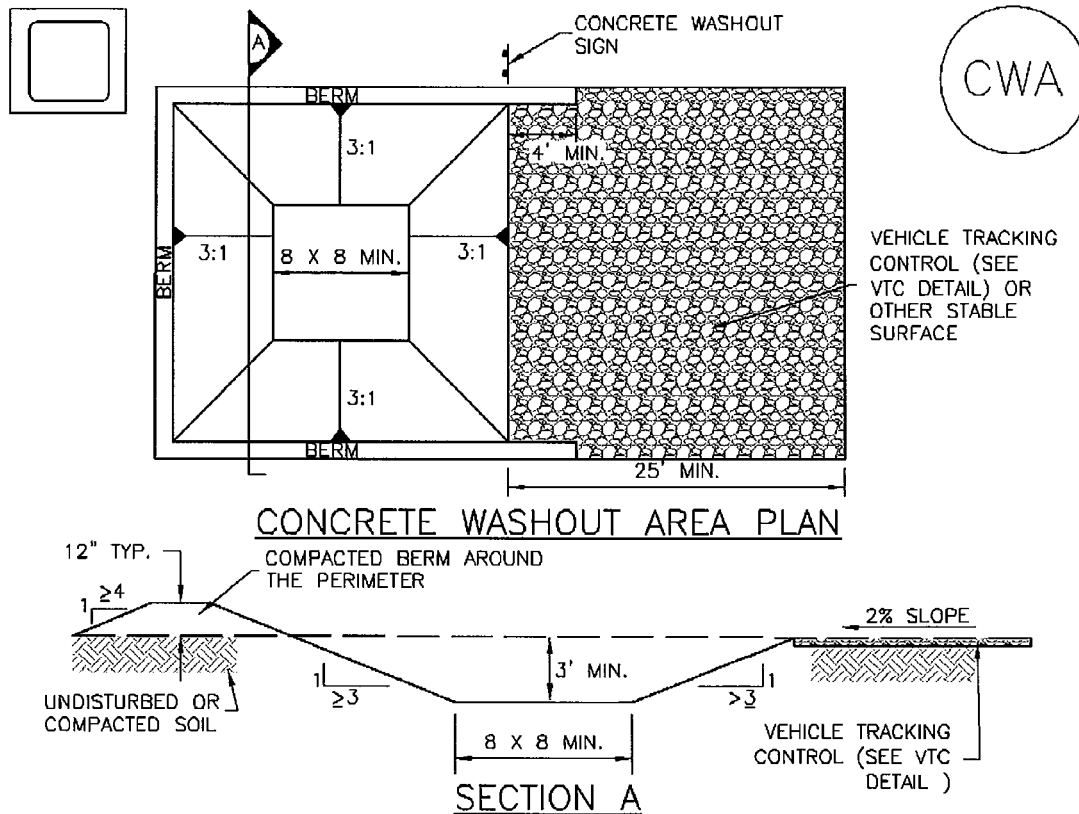

CWA-1. CONCRETE WASHOUT AREA

CWA INSTALLATION NOTES

1. SEE PLAN VIEW FOR:
-CWA INSTALLATION LOCATION.
2. DO NOT LOCATE AN UNLINED CWA WITHIN 400' OF ANY NATURAL DRAINAGE PATHWAY OR WATERBODY. DO NOT LOCATE WITHIN 1,000' OF ANY WELLS OR DRINKING WATER SOURCES. IF SITE CONSTRAINTS MAKE THIS INFEASIBLE, OR IF HIGHLY PERMEABLE SOILS EXIST ON SITE, THE CWA MUST BE INSTALLED WITH AN IMPERMEABLE LINER (16 MIL MIN. THICKNESS) OR SURFACE STORAGE ALTERNATIVES USING PREFABRICATED CONCRETE WASHOUT DEVICES OR A LINED ABOVE GROUND STORAGE ARE SHOULD BE USED.
3. THE CWA SHALL BE INSTALLED PRIOR TO CONCRETE PLACEMENT ON SITE.
4. CWA SHALL INCLUDE A FLAT SUBSURFACE PIT THAT IS AT LEAST 8' BY 8' SLOPES LEADING OUT OF THE SUBSURFACE PIT SHALL BE 3:1 OR FLATTER. THE PIT SHALL BE AT LEAST 3' DEEP.
5. BERM SURROUNDING SIDES AND BACK OF THE CWA SHALL HAVE MINIMUM HEIGHT OF 1'.
6. VEHICLE TRACKING PAD SHALL BE SLOPED 2% TOWARDS THE CWA.
7. SIGNS SHALL BE PLACED AT THE CONSTRUCTION ENTRANCE, AT THE CWA, AND ELSEWHERE AS NECESSARY TO CLEARLY INDICATE THE LOCATION OF THE CWA TO OPERATORS OF CONCRETE TRUCKS AND PUMP RIGS.
8. USE EXCAVATED MATERIAL FOR PERIMETER BERM CONSTRUCTION.

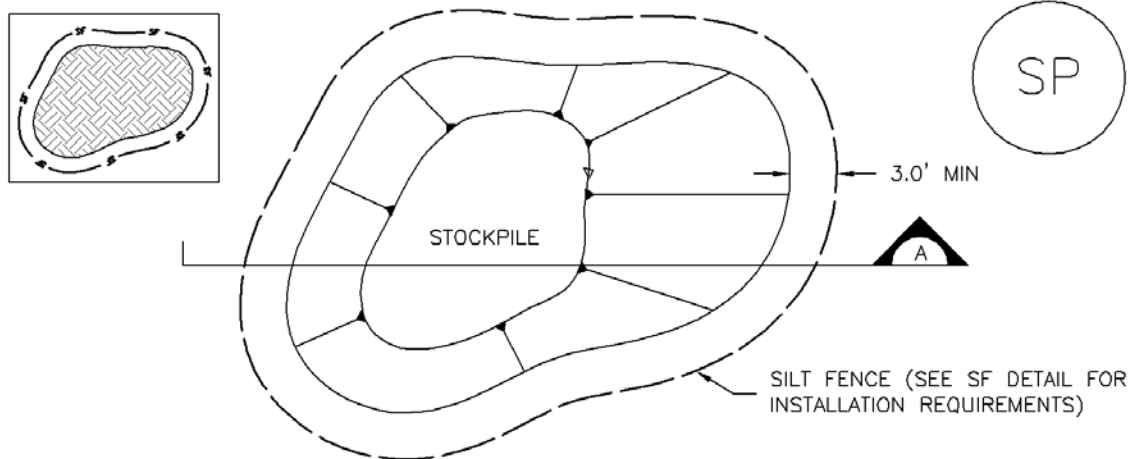

STOCKPILE PROTECTION PLAN

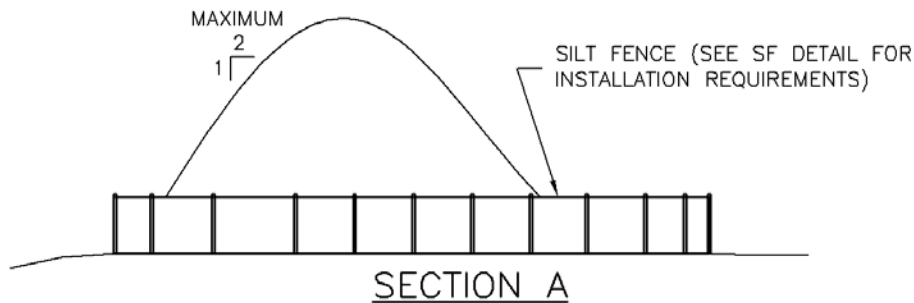

SP-1. STOCKPILE PROTECTION

STOCKPILE PROTECTION INSTALLATION NOTES

1. SEE PLAN VIEW FOR:
 - LOCATION OF STOCKPILES.
 - TYPE OF STOCKPILE PROTECTION.
2. INSTALL PERIMETER CONTROLS IN ACCORDANCE WITH THEIR RESPECTIVE DESIGN DETAILS. SILT FENCE IS SHOWN IN THE STOCKPILE PROTECTION DETAILS; HOWEVER, OTHER TYPES OF PERIMETER CONTROLS INCLUDING SEDIMENT CONTROL LOGS OR ROCK SOCKS MAY BE SUITABLE IN SOME CIRCUMSTANCES. CONSIDERATIONS FOR DETERMINING THE APPROPRIATE TYPE OF PERIMETER CONTROL FOR A STOCKPILE INCLUDE WHETHER THE STOCKPILE IS LOCATED ON A PERVIOUS OR IMPERVIOUS SURFACE, THE RELATIVE HEIGHTS OF THE PERIMETER CONTROL AND STOCKPILE, THE ABILITY OF THE PERIMETER CONTROL TO CONTAIN THE STOCKPILE WITHOUT FAILING IN THE EVENT THAT MATERIAL FROM THE STOCKPILE SHIFTS OR SLUMPS AGAINST THE PERIMETER, AND OTHER FACTORS.
3. STABILIZE THE STOCKPILE SURFACE WITH SURFACE ROUGHENING, TEMPORARY SEEDING AND MULCHING, EROSION CONTROL BLANKETS, OR SOIL BINDERS. SOILS STOCKPILED FOR AN EXTENDED PERIOD (TYPICALLY FOR MORE THAN 60 DAYS) SHOULD BE SEEDDED AND MULCHED WITH A TEMPORARY GRASS COVER ONCE THE STOCKPILE IS PLACED (TYPICALLY WITHIN 14 DAYS). USE OF MULCH ONLY OR A SOIL BINDER IS ACCEPTABLE IF THE STOCKPILE WILL BE IN PLACE FOR A MORE LIMITED TIME PERIOD (TYPICALLY 30-60 DAYS).
4. FOR TEMPORARY STOCKPILES ON THE INTERIOR PORTION OF A CONSTRUCTION SITE, WHERE OTHER DOWNGRADIENT CONTROLS, INCLUDING PERIMETER CONTROL, ARE IN PLACE, STOCKPILE PERIMETER CONTROLS MAY NOT BE REQUIRED.

STOCKPILE PROTECTION MAINTENANCE NOTES

1. INSPECT BMPs EACH WORKDAY, AND MAINTAIN THEM IN EFFECTIVE OPERATING CONDITION. MAINTENANCE OF BMPs SHOULD BE PROACTIVE, NOT REACTIVE. INSPECT BMPs AS SOON AS POSSIBLE (AND ALWAYS WITHIN 24 HOURS) FOLLOWING A STORM THAT CAUSES SURFACE EROSION, AND PERFORM NECESSARY MAINTENANCE.

2. FREQUENT OBSERVATIONS AND MAINTENANCE ARE NECESSARY TO MAINTAIN BMPs IN EFFECTIVE OPERATING CONDITION. INSPECTIONS AND CORRECTIVE MEASURES SHOULD BE DOCUMENTED THOROUGHLY.

3. WHERE BMPs HAVE FAILED, REPAIR OR REPLACEMENT SHOULD BE INITIATED UPON DISCOVERY OF THE FAILURE.

STOCKPILE PROTECTION MAINTENANCE NOTES

4. IF PERIMETER PROTECTION MUST BE MOVED TO ACCESS SOIL STOCKPILE, REPLACE PERIMETER CONTROLS BY THE END OF THE WORKDAY.

5. STOCKPILE PERIMETER CONTROLS CAN BE REMOVED ONCE ALL THE MATERIAL FROM THE STOCKPILE HAS BEEN USED.

(DETAILS ADAPTED FROM PARKER, COLORADO, NOT AVAILABLE IN AUTOCAD)

NOTE: MANY JURISDICTIONS HAVE BMP DETAILS THAT VARY FROM UDFCD STANDARD DETAILS. CONSULT WITH LOCAL JURISDICTIONS AS TO WHICH DETAIL SHOULD BE USED WHEN DIFFERENCES ARE NOTED.

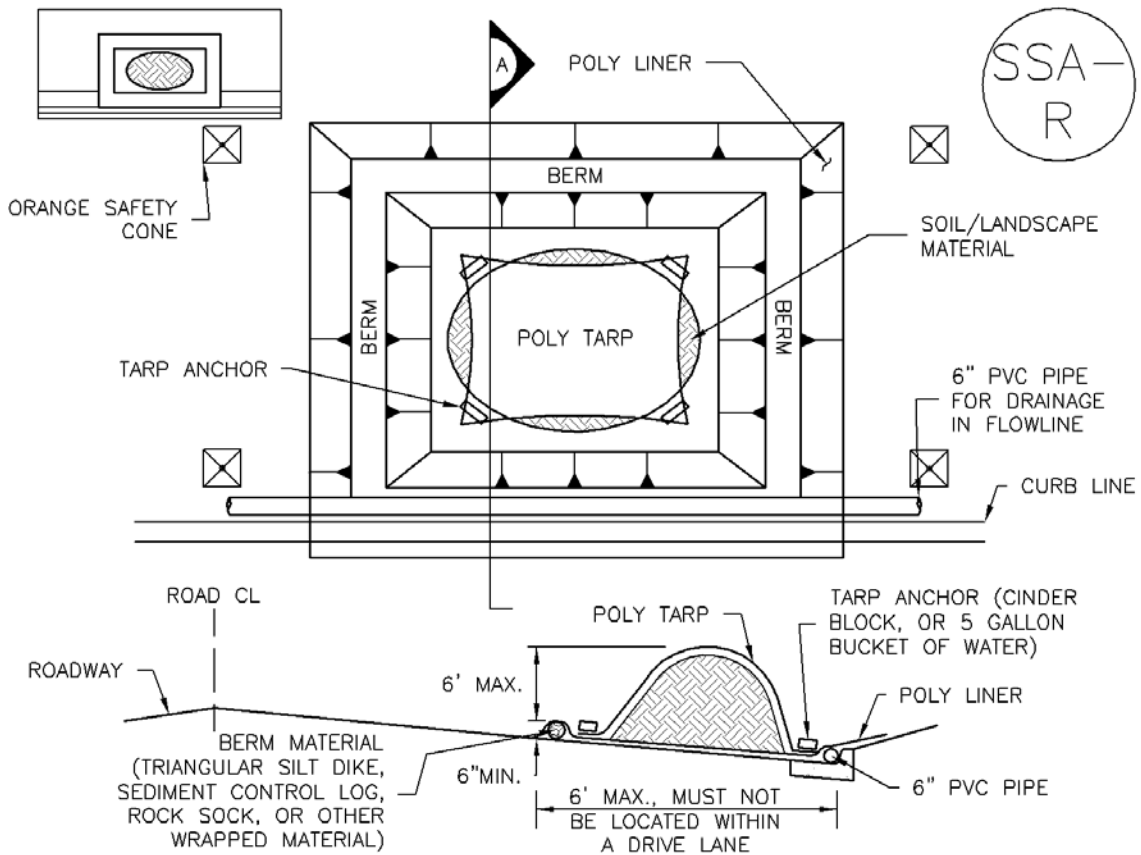

SP-2. MATERIALS STAGING IN ROADWAY

MATERIALS STAGING IN ROADWAYS INSTALLATION NOTES

1. SEE PLAN VIEW FOR
 - LOCATION OF MATERIAL STAGING AREA(S).
 - CONTRACTOR MAY ADJUST LOCATION AND SIZE OF STAGING AREA WITH APPROVAL FROM THE LOCAL JURISDICTION.
2. FEATURE MUST BE INSTALLED PRIOR TO EXCAVATION, EARTHWORK OR DELIVERY OF MATERIALS.
3. MATERIALS MUST BE STATIONED ON THE POLY LINER. ANY INCIDENTAL MATERIALS DEPOSITED ON PAVED SECTION OR ALONG CURB LINE MUST BE CLEANED UP PROMPTLY.
4. POLY LINER AND TARP COVER SHOULD BE OF SIGNIFICANT THICKNESS TO PREVENT DAMAGE OR LOSS OF INTEGRITY.
5. SAND BAGS MAY BE SUBSTITUTED TO ANCHOR THE COVER TARP OR PROVIDE BERMING UNDER THE BASE LINER.
6. FEATURE IS NOT INTENDED FOR USE WITH WET MATERIAL THAT WILL BE DRAINING AND/OR SPREADING OUT ON THE POLY LINER OR FOR DEMOLITION MATERIALS.
7. THIS FEATURE CAN BE USED FOR:
 - UTILITY REPAIRS.
 - WHEN OTHER STAGING LOCATIONS AND OPTIONS ARE LIMITED.
 - OTHER LIMITED APPLICATION AND SHORT DURATION STAGING.

MATERIALS STAGING IN ROADWAY MAINTENANCE NOTES

1. INSPECT BMPs EACH WORKDAY, AND MAINTAIN THEM IN EFFECTIVE OPERATING CONDITION. MAINTENANCE OF BMPs SHOULD BE PROACTIVE, NOT REACTIVE. INSPECT BMPs AS SOON AS POSSIBLE (AND ALWAYS WITHIN 24 HOURS) FOLLOWING A STORM THAT CAUSES SURFACE EROSION, AND PERFORM NECESSARY MAINTENANCE.
2. FREQUENT OBSERVATIONS AND MAINTENANCE ARE NECESSARY TO MAINTAIN BMPs IN EFFECTIVE OPERATING CONDITION. INSPECTIONS AND CORRECTIVE MEASURES SHOULD BE DOCUMENTED THOROUGHLY.
3. WHERE BMPs HAVE FAILED, REPAIR OR REPLACEMENT SHOULD BE INITIATED UPON DISCOVERY OF THE FAILURE.
4. INSPECT PVC PIPE ALONG CURB LINE FOR CLOGGING AND DEBRIS. REMOVE OBSTRUCTIONS PROMPTLY.
5. CLEAN MATERIAL FROM PAVED SURFACES BY SWEEPING OR VACUUMING.

NOTE: MANY JURISDICTIONS HAVE BMP DETAILS THAT VARY FROM UDFCD STANDARD DETAILS. CONSULT WITH LOCAL JURISDICTIONS AS TO WHICH DETAIL SHOULD BE USED WHEN DIFFERENCES ARE NOTED.

(DETAILS ADAPTED FROM AURORA, COLORADO)

SITE MAP/ GRADING, EROSION CONTROL PLAN



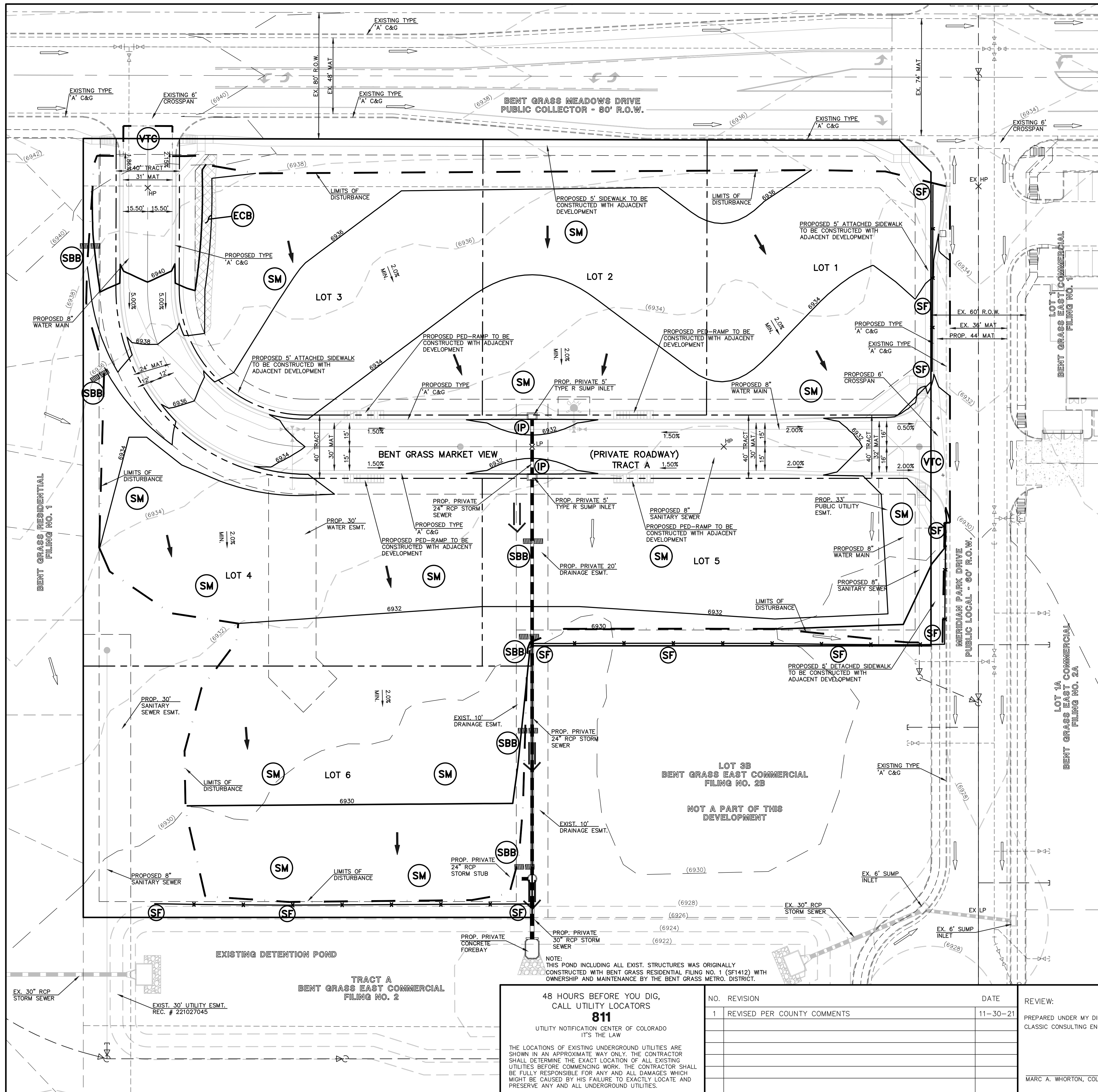

LEGEND

DESCRIPTION	SYMBOL
PROPOSED CONTOUR-10	
PROPOSED CONTOUR-2	
EXISTING CONTOUR-10	
EXISTING CONTOUR-2	
PROPERTY LINE	
BOUNDARY LINE	
PROPOSED PRIVATE STORM SEWER	
PROPOSED STORM INLET	
EXISTING STORM SEWER	
EXISTING STORM INLET	
EXISTING FIRE HYDRANT	
EXISTING WATER MAIN	
EXISTING SANITARY SEWER MAIN W/ MANHOLE	
PROPOSED SANITARY	
PROPOSED WATER	
LIMITS OF GRADING	
EXISTING FLOW DIRECTION	
PROPOSED FLOW	
HIGH POINT	HP
LOW POINT	LP
OVERFLOW ROUTE	
CUT/FILL LINE	
SILT FENCE	
VEHICLE TRACKING CONTROL	
STRAW BALES	
INLET PROTECTION	
EROSION CONTROL BLANKET	
EROSION CONTROL BLANKET (NORTH AMERICAN GREEN - SC150 OR EQUIVALENT) TO BE INSTALLED ON ALL 3:1 SLOPES OR GREATER	
SEEDING/MULCHING	

SEEDING/MULCHING NOTE:
SEEDING AND MULCHING SHALL BE INSTALLED INSIDE THE ENTIRE LIMITS OF GRADING EXCLUDING ROADWAY SURFACES, SIDEWALK AREAS AND RIP-RAP AREAS.

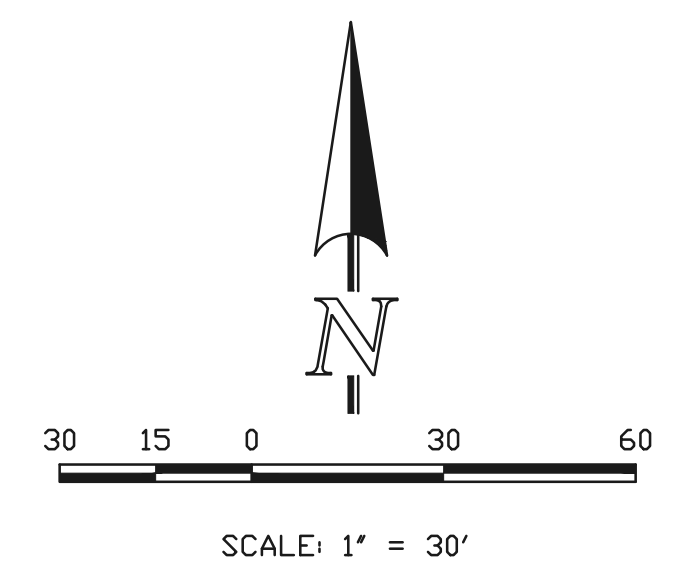

48 HOURS BEFORE YOU DIG,
CALL UTILITY LOCATORS
811
UTILITY NOTIFICATION CENTER OF COLORADO
IT'S THE LAW

THE LOCATIONS OF EXISTING UNDERGROUND UTILITIES ARE SHOWN IN AN APPROXIMATE WAY ONLY. THE CONTRACTOR SHALL DETERMINE THE EXACT LOCATION OF ALL EXISTING UTILITIES BEFORE COMMENCING WORK. THE CONTRACTOR SHALL BE FULLY RESPONSIBLE FOR ANY AND ALL DAMAGES WHICH MIGHT BE CAUSED BY HIS FAILURE TO EXACTLY LOCATE AND PRESERVE ANY AND ALL UNDERGROUND UTILITIES.

NO.	REVISION	DATE
1	REVISED PER COUNTY COMMENTS	11-30-21

REVIEW:
PREPARED UNDER MY DIRECT SUPERVISION FOR AND ON BEHALF OF CLASSIC CONSULTING ENGINEERS AND SURVEYORS, LLC
MARC A. WHORTON, COLORADO P.E. #37155 DATE



BENT GRASS EAST COMMERCIAL FILING NO. 3 OVERLOT GRADING & EROSION CONTROL PLAN			
DESIGNED BY	PRA	SCALE	DATE 04-21-21
DRAWN BY	PRA	(H) 1" = 30'	SHEET 3 OF 7
CHECKED BY	(V) 1" = N/A	JOB NO.	2177.64

