

DRAINAGE LETTER REPORT

for

NOR'WOOD BIBLE CHURCH LOT 38, SADDLEHORN RANCH FILING NO. 3

Prepared for:

ROI Property Group, LLC
2495 Rigdon Street
Napa, CA 94558

October 13, 2023
Revised January 15, 2024
Revised May 9, 2024
Revised June 28, 2024

Prepared by:

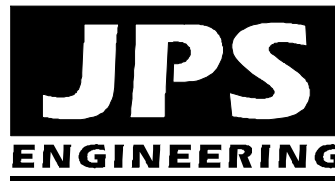

**19 E. Willamette Ave.
Colorado Springs, CO 80903
(719)-477-9429
www.jpsengr.com**

**JPS Project No. 042303
PCD Filing No. PPR2346**

**NOR'WOOD BIBLE CHURCH
LOT 38, SADDLEHORN RANCH FILING NO. 3
DRAINAGE LETTER REPORT
TABLE OF CONTENTS**

	<u>PAGE</u>
DRAINAGE STATEMENT	i
I. INTRODUCTION	1
II. EXISTING / PROPOSED DRAINAGE CONDITIONS	2
III. DRAINAGE PLANNING FOUR STEP PROCESS.....	5
IV. FLOODPLAIN IMPACTS.....	6
V. STORMWATER DETENTION AND WATER QUALITY	6
VI. PUBLIC IMPROVEMENTS / DRAINAGE BASIN FEES	6
VII. SUMMARY	7

APPENDICES

APPENDIX A	Excerpts from Subdivision Drainage Report
APPENDIX B	Hydrologic Calculations
APPENDIX C	Hydraulic Calculations
APPENDIX D	Drainage Cost Estimate
APPENDIX E	Figures
Sheet EX1	Existing Conditions Drainage Plan
Sheet PBMP	PBMP Applicability Exhibit
Sheet D1	Developed Drainage Plan

DRAINAGE STATEMENT

Engineer's Statement:

The attached drainage plan and report were prepared under my direction and supervision and are correct to the best of my knowledge and belief. Said drainage report has been prepared according to the criteria established by the County for drainage reports and said report is in conformity with the master plan of the drainage basin. I accept responsibility for liability caused by negligent acts, errors or omissions on my part in preparing this report.

John P. Schwab

John P. Schwab, P.E. #29891



Developer's Statement:

I, the developer have read and will comply with all of the requirements specified in this drainage report and plan.

By DocuSigned by:
Allyson Rubini manager Gorilla Capital CO Saddlehorn Ranch, LLC 8/6/2024

OWNER SIGNATURE DATE

El Paso County's Statement

Filed in accordance with the requirements of the El Paso County Land Development Code, Drainage Criteria Manual, Volumes 1 and 2, and Engineering Criteria Manual as amended.

Joshua Palmer, P.E.
County Engineer / ECM Administrator

Date

Conditions:

I. INTRODUCTION

A. Property Location and Description

Nor’ Wood Bible Church is planning to construct a new church on a vacant 5-acre property in the Saddlehorn Ranch Subdivision southeast of the intersection of Judge Orr Road and Curtis Road in eastern El Paso County, Colorado. The property is currently being platted as Lot 38, Saddlehorn Ranch Filing No. 3 (currently a part of the tract identified as El Paso County Assessor’s Parcel Number 43000-00-635). The site is located along the east side of Barrosito Trail.

The project consists of a new 12,000 square-foot, single-story Church Building with associated parking and site improvements. The property is bounded by platted rural residential lots within Saddlehorn Ranch Filing No. 3 along the west, south, and east sides. The north boundary of the property adjoins Judge Orr Road, which is an asphalt-paved arterial public street. The west boundary of the site adjoins Barrosito Trail, which is an asphalt-paved local public street.

The total anticipated land disturbance associated with the project is approximately 3.8 acres.

The property is zoned RR-2.5 (Rural Residential – 2.5-acre minimum lot sizes), and the proposed site development is a permitted use within the existing zoning of the site. Access to the site will be provided by a private driveway connection to Barrosito Trail along the west boundary of the property.

The site is located in the Haegler Ranch Drainage Basin, and surface drainage from this site flows southeasterly to existing drainage swales and channels, ultimately flowing to Black Squirrel Creek.

JR Engineering, LLC prepared the “Final Drainage Report for Saddlehorn Ranch – Filing 3,” dated April 22, 2024 (EDARP Project No. SF234) which provides detailed drainage planning for the subdivision filing including this lot. This report is intended to meet the requirements of a site-specific “Letter Type” drainage report in accordance with El Paso County subdivision drainage criteria.

B. Drainage Analysis Methods and Criteria

ITEM	DESCRIPTION	REFERENCE
Design Storm (initial/major)	5-year/100-year	CS/EPC DCM
Storm Runoff	Rational Method (Area<100acres)	CS/EPC DCM
Major Drainage Basin	Haegler Ranch	
Floodplain Impacts	Parcel is located outside any delineated FEMA floodplains	FIRM
Existing Downstream Facilities	Existing roadside ditches and culverts flowing to Saddlehorn Ranch Detention Pond D	

CS/EPC DCM = City of Colorado Springs & El Paso County Drainage Criteria Manual

C:\Users\Owner\Dropbox\jpsprojects\042303.saddlehorn\admin\drainage\Drg-Ltr-Norwood-Bible-0624.docx

C. References

City of Colorado Springs & El Paso County “Drainage Criteria Manual, Volumes 1 and 2,” revised May, 2014.

El Paso County “Engineering Criteria Manual,” December 13, 2016.

JR Engineering, LLC, “Final Drainage Report (FDR) for Saddlehorn Ranch – Filing 3,” April 22, 2024 (EDARP Project No. SF234).

JR Engineering, LLC, “Master Development Drainage Plan and Preliminary Drainage Report for Saddlehorn Ranch,” May 8, 2020.

II. EXISTING / PROPOSED DRAINAGE CONDITIONS

The site slopes downward to the southeast, with average grades of 1-4 percent.

As detailed in the subdivision drainage report, on-site soils are classified by SCS as type 19, “Columbine gravelly sandy loam” soils. These soils have high infiltration rates, rapid permeability, and low runoff potential. The soils are classified as hydrologic soils group A.

Subdivision Drainage Report

Drainage planning for this site was previously studied in the detailed subdivision drainage report entitled “Final Drainage Report (FDR) for Saddlehorn Ranch – Filing 3,” dated July 13, 2023, by JR Engineering, LLC. According to the FDR, the proposed church site lies within Basin D1, which is described as follows:

“Basin D consists of Sub-basins D1-D7 combining for a total of 74.66 acres. In its existing condition, Basin D is rolling rangeland and runoff generally flows east to Drainageway WF-R7A. In the proposed condition, Basin D will be rural 2.5 acre lots, paved roadway, a church site and will include Pond D located in the northeast corner of the future Filing 4 development. Pond D is a full spectrum water quality and detention pond, and will release at less than historic rates into Drainageway WF-R7A.”

The FDR identifies Basin D1 as having developed peak flows of $Q_5 = 4.2$ cfs and $Q_{100} = 13.5$ cfs (see “Proposed Drainage Map, Sheet 1 of 4” Appendix A). The subdivision drainage report accounted for the proposed church site development within Basin D1, and the church site layout depicted on the subdivision drainage plan is fully consistent with the currently proposed site development plan. “Proposed Drainage Map, Sheet 2 of 4” depicts the downstream roadside ditches and culverts flowing easterly along Barrosito Trail and Barranca Place into Detention Pond D.

The rational method hydrologic calculations in the FDR assumed an impervious area of 35% for the church site development (see Appendix A), which is slightly higher than the actual impervious area calculated for the proposed church site (30.5% as tabulated in Appendix B).

Existing Conditions Drainage Plan

For consistency with the previously approved subdivision drainage report, the church site has been delineated as Basin D1.1 (see Sh. EX1, Appendix E). The church site is not impacted by any off-site runoff. The existing vacant site sheet flows towards the southeast corner of the property, with existing peak flows calculated as $Q_5 = 1.1$ cfs and $Q_{100} = 7.8$ cfs.

Developed Drainage Plan

General Description

As shown on the Developed Drainage Plan (Sh. D1, Appendix D), the proposed church site has been delineated as Basin D1.1, which drains by sheet flow, curb and gutter, and drainage swales to the roadside ditch at the southeast corner of the property. Basin D1.1 in this report is a subset of “Basin D1” identified in the FDR, comprising only the church site.

Developed flows have been calculated based on the impervious areas associated with the proposed building and parking improvements. The enclosed calculations include the currently proposed building and parking areas along with the future pole barn building and gravel parking areas identified on the Developed Drainage Plan.

The proposed building pad will be graded with protective slopes to provide positive drainage away from the building, and the curb, gutter, crosspans, and drainage swales will convey developed flows to the existing roadside ditch at the southeast corner of the site. Runoff reduction will be provided by routing developed flows through grass-lined drainage ditches and channels within the property.

As detailed in the subdivision drainage report, the downstream ditches and culverts have been designed to convey developed flows from the church site to Saddlehorn Ranch Detention Pond D, which provides stormwater detention and water quality for this site.

Developed Sub-Basins

Sub-Basin D1.1a (1.5-acres) has been delineated as the developed drainage area at the north end of the property, which flows southeasterly around the proposed church building in proposed grass-lined Ditch D1.1a. Developed peak flows from Sub-Basin D1.1a are calculated as $Q_5 = 0.8$ cfs and $Q_{100} = 3.5$ cfs.

Sub-Basin D1.1b (0.4-acres) has been delineated as the developed drainage area on the east side of the new building, which flows southeasterly around the proposed building in proposed grass-lined Ditch D1.1b. Flows from Sub-Basins D1.1a and D1.1b combine at Design Point D1.1b, with developed peak flows calculated as $Q_5 = 1.3$ cfs and $Q_{100} = 4.8$ cfs.

Sub-Basin D1.1c (1.9-acres) has been delineated as the developed drainage area comprising the southwest part of the new church building and the majority of the parking lot, which flows southeasterly to Grass-Lined Channel D1.1c. Developed peak flows from Sub-Basin D1.1c are calculated as $Q_5 = 3.9$ cfs and $Q_{100} = 8.5$ cfs.

Sub-Basin D1.1d (0.8-acres) has been delineated as the developed drainage area on the south end of the property, which flows southeasterly to the roadside ditch along the north side of Barrosito Trail. Flows from Sub-Basins D1.1a-D1.1d combine at Design Point D1.1d, with developed peak flows calculated as $Q_5 = 4.7$ cfs and $Q_{100} = 12.9$ cfs. Grass-lined Channel D1.1d will convey the combined flow from Sub-Basins D1.1a-D1.1d to the public ditch at the southeast corner of the property.

Sub-Basin D1.1e (0.14-acres) has been delineated as the narrow area within the Barrosito Trail right-of-way along the southwest frontage of the property, which flows southeasterly in the roadside ditch along the northeast side of Barrosito Trail. Flows from Sub-Basins D1.1e are calculated as $Q_5 = 0.1$ cfs and $Q_{100} = 0.18$ cfs.

The subdivision drainage report identified proposed driveway culverts at the church access points as Culverts CH1 and CH2 (see JR Drainage Plan in Appendix A). Based on the final site plan, the northerly driveway shown in the subdivision drainage report has been eliminated, so only Culvert CH2 will be constructed. The drainage area along the northwest frontage of the site draining to the proposed driveway culvert has been identified as Basin CH2 for consistency with the subdivision drainage report. Basin CH2 flows southeasterly in the roadside ditch along the east side of Barrosito Trail, with developed peak flows calculated as $Q_5 = 0.9$ cfs and $Q_{100} = 2.5$ cfs. Culvert CH2 was sized as an 18" RCP culvert in the subdivision drainage report based on a design flow of $Q_5 = 2.8$ cfs and $Q_{100} = 9.1$ cfs (see Appendix A). The actual developed flows reaching the driveway culvert at Design Point CH2 are lower than anticipated in the subdivision drainage report, and the 18" RCP culvert size is adequate for the site access drive.

Summary

Flows from Sub-Basins D1.1a-D1.1d and Basin CH2 combine at Design Point D1.1 in the southeast corner of the property, with developed peak flows calculated as $Q_5 = 5.4$ cfs and $Q_{100} = 14.9$ cfs. The church site is not impacted by any off-site runoff.

As previously noted, the total impervious area for the church site (Lot 38) identified in this report (30.5%) is below the impervious area assumed for the church site in the FDR ("conservatively rounded to 35%" as detailed in JR Engineering Report; see excerpt in Appendix A). The impervious area in this report is lower than previously assumed in the

subdivision drainage report by JR Engineering. As such, the downstream drainage facilities and detention pond have been sized to account for the fully developed flows from the church site.

Saddlehorn Ranch Subdivision Detention Pond D will provide long-term stormwater detention and water quality treatment for this site. Detention Pond D will be constructed as part of the subdivision infrastructure for Saddlehorn Ranch Filing No. 3, in advance of this church project. Detention Pond D is a control measure owned and operated by the Saddlehorn Metropolitan District, as documented in the Final Drainage Report, O&M Manual, Detention Maintenance Agreement and related documents under Saddlehorn Ranch Subdivision Filing No. 3 (EDARP Project No. SF234).

Channel hydraulic calculations have been performed to evaluate stability of the proposed ditches and drainage swales within the site. As detailed in Appendix C, erosion-control blanket lining has been specified for Channel D1.1b and Channel D1.1c to mitigate potential concerns with channel velocities.

Hydrologic and hydraulic calculations for the site are detailed in the appendices (Appendix B and C), and peak flows are identified on Figure D1 (Appendix E).

III. DRAINAGE PLANNING FOUR STEP PROCESS

El Paso County Drainage Criteria require drainage planning to include a Four Step Process for receiving water protection that focuses on reducing runoff volumes, treating the water quality capture volume (WQCV), stabilizing drainageways, and implementing long-term source controls.

As stated in ECM Appendix I.7., the Four Step Process is applicable to all new and re-development projects with construction activities that disturb 1 acre or greater or that disturb less than 1 acre but are part of a larger common plan of development. The Four Step Process has been implemented as follows in the planning of this project:

Step 1: Employ Runoff Reduction Practices

- Minimize Directly Connected Impervious Areas (MDCIA): Roof drain downspouts will flow across grass-lined drainage swales, ditches, and channels within the property prior to reaching the downstream roadside ditch.
- Grass-Lined Drainage Swales: Grass-lined drainage swales, ditches, and channels have been designed to convey developed drainage across the site, encouraging stormwater infiltration while flowing to the existing downstream roadside ditch.

Step 2: Stabilize Drainageways

- There are no drainageways directly adjacent to this project site. The on-site private drainage improvements will convey developed flows to the existing downstream roadside ditches and culverts flowing to the subdivision detention basin which has been designed to minimize downstream drainage impacts.

- Drainage basin fees paid during recording of the subdivision plat provide the applicable cost contribution towards regional drainage improvements.

Step 3: Provide Water Quality Capture Volume (WQCV)

- Water quality treatment for this site is provided in the subdivision detention pond (Saddlehorn Ranch Subdivision Detention Pond D; constructed with Saddlehorn Ranch Subdivision Filing No. 3; EDARP Project No. SF234).

Step 4: Consider Need for Industrial and Commercial BMPs

- No industrial uses are proposed for this site.
- The church property owner will implement a Stormwater Management Plan including proper housekeeping practices and spill containment procedures.

IV. FLOODPLAIN IMPACTS

According to the FEMA floodplain map for this area, El Paso County FIRM Panel No. 08041C0558G, dated December 7, 2018, the site is located beyond the limits of any delineated 100-year floodplains. The site is identified as being in Zone X, which is defined as areas outside of the Special Flood Hazard Area (SFHA) and higher than the elevation of the 0.2-percent annual chance (or 500-year) flood.

V. STORMWATER DETENTION AND WATER QUALITY

Stormwater detention and water quality for this site is provided in Saddlehorn Ranch Detention Pond D, which was sized to account for fully developed flows from this church site. Detention Pond D is a control measure owned and operated by the Saddlehorn Metropolitan District, as documented in the Final Drainage Report, O&M Manual, Detention Maintenance Agreement and related documents under Saddlehorn Ranch Subdivision Filing No. 3 (EDARP Project No. SF234). The subdivision infrastructure improvements for Saddlehorn Ranch Filing No. 3 are currently under construction, and financial assurances have been posted by the developer to ensure that the subdivision drainage facilities and detention pond function as intended.

As stated in the FDR, “In the proposed condition, Basin D will be rural 2.5 acre lots, paved roadway, a church site and will include Pond D located in the northeast corner of the future Filing 4 development. Pond D is a full spectrum water quality and detention pond, and will release at less than historic rates into Drainageway WF-R7A.”

As detailed in Appendix B, the calculated impervious area for the proposed site development is 30.5 percent, which is lower than the impervious area of 35 percent that was previously assumed for the church site in the subdivision drainage report (“conservatively rounded to 35%” as detailed in JR Engineering Report; see excerpt in Appendix A). Based on the site impervious areas in this report being below the estimate in the subdivision drainage report, the corresponding runoff coefficients and impervious areas within Basin D1 will also remain below the FDR assumptions. As a result, there

will be no increase in the developed flows calculated for Basin D1 in the FDR. As such, the downstream drainage and detention facilities have been designed conservatively to fully account for the church site development.

VI. PUBLIC IMPROVEMENTS / DRAINAGE BASIN FEES

No public drainage improvements are required or proposed for the church site development project. The estimated cost of the on-site private drainage improvements is approximately \$8,235, as detailed in Appendix D.

The site lies completely within the Haegler Ranch Drainage Basin. Applicable drainage basin fees were due at the time of subdivision platting, so no drainage basin fees or bridge fees are applicable at this time.

VII. SUMMARY

The developed drainage patterns for the proposed Nor'Wood Bible Church site development on Lot 38, Saddlehorn Ranch Filing No. 3 will be fully consistent with the assumptions in the approved subdivision drainage report. The grading and drainage plan for the proposed church site development fully conforms to the approved drainage plan for this subdivision.

Developed flows from the site will drain through on-site grass-lined drainage swales, ditches, and channels, flowing into the public roadside ditch at the southeast corner of the property. The downstream roadside ditches and culverts flow into Saddlehorn Ranch Detention Pond D, which has been designed to provide stormwater detention and water quality for the proposed church site development.

Construction and proper maintenance of the on-site drainage facilities, in conjunction with proper erosion control practices, will ensure that this developed site has no significant adverse drainage impact on downstream or surrounding areas.

APPENDIX A

EXCERPTS FROM SUBDIVISION DRAINAGE REPORT

**FINAL DRAINAGE REPORT
FOR
SADDLEHORN RANCH – FILING 3**

**Prepared For:
ROI Property Group, LLC
2495 Rigdon Street
Napa, CA 94558
(707) 365-6891**

**April 22, 2024
Project No. 25142.05**

**Prepared By:
JR Engineering, LLC
5475 Tech Center Drive
Colorado Springs, CO 80919
719-593-2593**

**El Paso County PCD File No.:
SF234**

Existing Sub-basin Drainage

On-site, existing sub-basin drainage patterns are generally from northwest to southeast by way of Drainageway MS-06 and Drainageway WF-R7A. On-site areas flow directly into these drainageways, which also bypass off-site flows through the site.

On-site, existing drainage basins were established based upon existing topography and the limits of the 100-year floodplain. These existing sub-basins were analyzed in the *Master Development Drainage Plan and Preliminary Drainage Report for Saddlehorn Ranch*. An existing drainage map has been provided in Appendix E.

Proposed Sub-basin Drainage

The proposed Filing 3 basin delineation is as follows;

Basin C consists of Sub-Basins C1-C10 combining for a total of 93.77 acres. In its existing condition, Basin C is rolling rangeland and runoff generally flows southeast towards Drainageway MS-06. In the proposed condition, Basin C will be rural 2.5 acre lots, paved roadway, and will include Pond C. Runoff from this basin will be collected in road side ditches and conveyed to Pond C located in the southeast corner of the future Filing 4 development. Pond C will be a full spectrum water quality and detention pond, and will release at less than historic rates into Drainageway MS-06.

Basin D consists of Sub-basins D1-D7 combining for a total of 74.66 acres. In its existing condition, Basin D is rolling rangeland and runoff generally flows east to Drainageway WF-R7A. In the proposed condition, Basin D will be rural 2.5 acre lots, paved roadway, a church site and will include Pond D. Runoff from this basin will be collected in road side ditches and conveyed west to Pond D located in the northeast corner of the future Filing 4 development. Pond D is a full spectrum water quality and detention pond, and will release at less than historic rates into Drainageway WF-R7A.

Basin E consists of Sub-basins E1-E4 combining for a total of 18.37 acres. In its existing condition, Basin E is rolling rangeland and runoff generally flows south towards Drainageway MS-06. In the proposed condition, Basin E will be rural 2.5 acre lots, paved roadway, and will include Pond E. Runoff from this basin will be collected in road side ditches and conveyed to Pond E located in the southern portion of the Filing 3 development along San Isidro Trail. Pond E will be a full spectrum water quality and detention pond, and will release at less than historic rates into Drainageway MS-06.

Basin F consists of Sub-basins F1-F4 combining for a total of 14.32 acres. In its existing condition, Basin F is rolling rangeland and paved road (Curtis Road and Benito Wells Trail). Runoff generally flows east along Benito Wells Trail. In the proposed condition, Basin F will be rural 2.5 acre lots and paved roadway. Runoff from this basin will be collected in road side ditches and conveyed to Pond F located in the southeastern portion of the Filing 2 development along Benito Wells Trail. Pond F will be a full spectrum water quality and detention pond, and will release at less than historic rates into Drainageway MS-06.

Basin UD consists of Sub-basins UD1-UD5 combining for a total of 74.27 acres. In their existing condition, these basins are rolling rangeland. Runoff from Basins UD1-UD3 generally flows south and

**Final Drainage Report
Filing 3 - Saddlehorn Ranch**

east to Drainageway MS-06. Basin UD5 flows east to Drainageway MS-06. Basin UD4 represents Drainageway MS-06 and the runoff generated along the Filing 3 boundary. In the proposed condition, Basins UD1, UD2, UD3, and most of UD5 will be rural 2.5 acre lots with an Imperviousness = 6.2% and will be excluded from permanent stormwater quality management per Section I.7.1.B.5 of the ECM – Stormwater Quality Policy and Procedures. Per the MS4 Permit Exclusion Map, 0.53 acres of Basin UD5, which consists of paved roads at 45% imperviousness, will be excluded per Section I.7.1.C.1. shown in red. Additionally, the entirety of Basin UD4, which is a non-jurisdictional wetland to remain undeveloped at 2% impervious, will not be detained in PBMP per section I.7.1.B.7.

Basin OS consists of Sub-basins OS1-OS5 combining for a total of 9.35 acres of offsite area. In their existing condition, these basins are paved roadway (Curtis Road & Judge Orr Road) and undeveloped area. In the proposed condition, these basins will be improved with 8' of pavement width for both the Curtis Road and Judge Orr Road stretches. Basins OS1-OS4 will flow on-site prior to being captured in a roadside swale and conveyed to a proposed full spectrum detention pond prior to being released into Drainageway MS-06 or Drainageway WF-R7A. Basin OS5 will not be detained by a pond due to its location relative to the site. The improvements along Curtis Road within Basin OS5 will follow historic patterns and drain directly into Drainageway MS-06.

A summary table of proposed basin parameters and flow rates are presented in Appendix B.

Basin C runoff along with runoff from Sub-Basins OS1 and OS2 will be captured in roadside swales and conveyed to the proposed Pond C. This full spectrum pond will release treated flows at less than historic rates to minimize adverse impacts downstream. Basin D along with runoff from Sub-Basins OS3 and OS4 will be captured in roadside swales and conveyed to the proposed Pond D. Basin E will be captured in roadside swales and conveyed to the proposed Pond E. Pond C and Pond E will discharge into Drainageway MS-06. Pond D will discharge into Drainageway WF-R7A.

See Table 3 below for proposed Filing 3 pond parameters.

Table 3: Pond Summary

Tributary Sub-Basin	Pond Name	Tributary Acres	WQ Volume (ac-ft)	Total Detention Volume (ac-ft)	Provided Volume (ac-ft)	Maximum 100-Year Discharge (cfs)
C	POND C	96.84	0.737	3.064	4.235	41.2
D	POND D	78.02	0.673	3.026	3.127	60.9
E	POND E	18.37	0.086	0.419	0.424	9.2

Drainageway MS-06

Drainageway MS-06 was evaluated in its existing conditions as part of the Filing 2 report to analyze the existing flood plain and channel stability. The proposed improvements for the upper reach (5,300 FT) of this Filing 3 adjacent drainage way have been evaluated in this Filing 3 Drainage report. In

COMPOSITE % IMPERVIOUS CALCULATIONS

Subdivision: Saddlehorn Ranch Filing 3
 Location: El Paso County

Project Name: Saddlehorn Ranch
 Project No.: 25142.05
 Calculated By: AAM
 Checked By: TBD
 Date: 6/16/23

Basin ID	Total Area (ac)	Paved Roads			2.5 Acre Rural Lots			Lawns			Church Site			Basins Total Weighted % Imp.
		% Imp.	Area (ac)	Weighted % Imp.	% Imp.	Area (ac)	Weighted % Imp.	% Imp.	Area (ac)	Weighted % Imp.	% Imp.	Area (ac)	Weighted % Imp.	
C1	6.04	45%	1.07	8.0%	6.2%	4.97	5.1%	2%	0.00	0.0%	35%	0.00	0.0%	13.1%
C2	3.35	45%	1.50	20.1%	6.2%	1.85	3.4%	2%	0.00	0.0%	35%	0.00	0.0%	23.6%
C3	23.44	45%	1.63	3.1%	6.2%	21.81	5.8%	2%	0.00	0.0%	35%	0.00	0.0%	8.9%
C4	10.94	45%	3.40	14.0%	6.2%	7.54	4.3%	2%	0.00	0.0%	35%	0.00	0.0%	18.3%
C5	2.35	45%	0.83	15.9%	6.2%	1.52	4.0%	2%	0.00	0.0%	35%	0.00	0.0%	19.9%
C6	3.95	45%	1.59	18.1%	6.2%	2.36	3.7%	2%	0.00	0.0%	35%	0.00	0.0%	21.8%
C7	2.14	45%	1.00	21.0%	6.2%	1.14	3.3%	2%	0.00	0.0%	35%	0.00	0.0%	24.3%
C8	22.55	45%	2.21	4.4%	6.2%	20.34	5.6%	2%	0.00	0.0%	35%	0.00	0.0%	10.0%
C9	2.63	45%	1.98	33.9%	6.2%	0.65	1.5%	2%	0.00	0.0%	35%	0.00	0.0%	35.4%
C10	16.38	45%	2.47	6.8%	6.2%	11.85	4.5%	2%	2.06	0.3%	35%	0.00	0.0%	11.5%
D1	9.11	45%	1.53	7.6%	6.2%	2.70	1.8%	2%	0.00	0.0%	35%	4.88	18.7%	28.1%
D2	8.49	45%	1.49	7.9%	6.2%	7.00	5.1%	2%	0.00	0.0%	35%	0.00	0.0%	13.0%
D3	3.21	45%	0.19	2.7%	6.2%	3.02	5.8%	2%	0.00	0.0%	35%	0.00	0.0%	8.5%
D4	10.01	45%	0.35	1.6%	6.2%	8.21	5.1%	2%	1.45	0.3%	35%	0.00	0.0%	6.9%
D5	9.56	45%	2.78	13.1%	6.2%	6.78	4.4%	2%	0.00	0.0%	35%	0.00	0.0%	17.5%
D6	0.34	45%	0.34	45.0%	6.2%	0.00	0.0%	2%	0.00	0.0%	35%	0.00	0.0%	45.0%
D7	33.94	45%	7.65	10.1%	6.2%	24.05	4.4%	2%	2.24	0.1%	35%	0.00	0.0%	14.7%
E1	17.12	45%	0.71	1.9%	6.2%	13.22	4.8%	2%	3.19	0.4%	35%	0.00	0.0%	7.0%
E2	0.37	45%	0.37	45.0%	6.2%	0.00	0.0%	2%	0.00	0.0%	35%	0.00	0.0%	45.0%
E3	0.20	45%	0.20	45.0%	6.2%	0.00	0.0%	2%	0.00	0.0%	35%	0.00	0.0%	45.0%
E4	0.68	45%	0.00	0.0%	6.2%	0.19	1.7%	2%	0.49	1.4%	35%	0.00	0.0%	3.2%
UD1	7.48	45%	0.00	0.0%	6.2%	7.48	6.2%	2%	0.00	0.0%	35%	0.00	0.0%	6.2%
UD2	9.17	45%	0.00	0.0%	6.2%	9.17	6.2%	2%	0.00	0.0%	35%	0.00	0.0%	6.2%
UD3	2.23	45%	0.00	0.0%	6.2%	2.23	6.2%	2%	0.00	0.0%	35%	0.00	0.0%	6.2%
UD4	34.90	45%	0.00	0.0%	6.2%	0.00	0.0%	2%	34.90	2.0%	35%	0.00	0.0%	2.0%
UD5	17.63	45%	0.00	0.0%	6.2%	17.63	6.2%	2%	0.00	0.0%	35%	0.00	0.0%	6.2%
OS1	2.37	100%	1.35	57.0%	6.2%	0.00	0.0%	2%	1.02	0.9%	35%	0.00	0.0%	57.8%
OS2	0.70	100%	0.21	30.0%	6.2%	0.00	0.0%	2%	0.49	1.4%	35%	0.00	0.0%	31.4%
OS3	2.28	100%	1.35	59.2%	6.2%	0.00	0.0%	2%	0.93	0.8%	35%	0.00	0.0%	60.0%
OS4	1.08	100%	0.58	53.7%	6.2%	0.00	0.0%	2%	0.50	0.9%	35%	0.00	0.0%	54.6%
OS5	2.92	100%	0.59	20.2%	6.2%	0.94	2.0%	2%	1.39	1.0%	35%	0.00	0.0%	23.2%
F1	1.35	100%	0.53	39.3%	6.2%	0.00	0.0%	2%	0.82	1.2%	35%	0.00	0.0%	40.5%
F2	7.67	45%	0.98	5.7%	6.2%	6.69	5.4%	2%	0.00	0.0%	35%	0.00	0.0%	11.2%
F3	5.44	45%	2.37	19.6%	6.2%	3.07	3.5%	2%	3.07	1.1%	35%	0.00	0.0%	24.2%
F4	2.93	45%	2.93	45.0%	6.2%	0.00	0.0%	2%	0.00	0.0%	35%	0.00	0.0%	45.0%
TOTAL	284.95													12.9%

Land Use or Surface Characteristics	Percent Impervious	Runoff Coefficients											
		2-year		5-year		10-year		25-year		50-year		100-year	
		Imp. Area	Imp. Coef.	Imp. Area	Imp. Coef.	Imp. Area	Imp. Coef.	Imp. Area	Imp. Coef.	Imp. Area	Imp. Coef.	Imp. Area	Imp. Coef.
Business													
Commercial Area	95	0.79	0.80	0.81	0.82	0.83	0.84	0.85	0.87	0.88	0.88	0.89	0.89
HighSchool Area	90	0.45	0.49	0.48	0.51	0.53	0.57	0.58	0.62	0.65	0.65	0.67	0.68
Residential													
1.5 Acre or less	65	0.43	0.45	0.45	0.49	0.49	0.54	0.54	0.59	0.57	0.62	0.59	0.60
1.5-4 Acre	40	0.28	0.28	0.30	0.35	0.35	0.41	0.41	0.50	0.56	0.54	0.55	0.58
4-10 Acre	30	0.18	0.22	0.22	0.29	0.31	0.38	0.39	0.47	0.48	0.52	0.47	0.57
10-20 Acre	25	0.15	0.20	0.22	0.28	0.30	0.36	0.37	0.46	0.43	0.51	0.46	0.56
1 Acre	20	0.12	0.17	0.20	0.26	0.27	0.34	0.35	0.44	0.40	0.49	0.44	0.55
Industrial													
Light Area	80	0.57	0.60	0.59	0.63	0.63	0.68	0.67	0.72	0.68	0.72	0.70	0.74
Heavy Area	90	0.71	0.75	0.73	0.75	0.75	0.77	0.78	0.80	0.80	0.82	0.81	0.85
Parkland/Composites	7	0.05	0.05	0.11	0.11	0.23	0.23	0.30	0.40	0.34	0.46	0.39	0.50
Playgrounds	15	0.07	0.13	0.15	0.23	0.24	0.31	0.32	0.42	0.37	0.48	0.41	0.54
Unimproved Yard Areas	40	0.24	0.28	0.30	0.35	0.36	0.42	0.42	0.50	0.46	0.54	0.50	0.58
Unimproved Areas													
Woods/Open Fields													
Greenbelts/Agriculture	5	0.08	0.05	0.09	0.16	0.17	0.26	0.26	0.38	0.31	0.45	0.36	0.51
Pasture/Meadow	0	0.02	0.04	0.08	0.15	0.15	0.25	0.25	0.37	0.30	0.44	0.35	0.50
Fields	0	0.02	0.04	0.08	0.15	0.15	0.25	0.25	0.37	0.30	0.44	0.35	0.50
Grassland/Park	100	0.87	0.89	0.90	0.90	0.90	0.92	0.94	0.95	0.95	0.95	0.96	0.96
Other Run-off Areas (lawns, landscape, sand/bedrock)	40	0.26	0.31	0.32	0.37	0.38	0.44	0.44	0.51	0.48	0.56	0.51	0.59
Streets													
Paved	100	0.89	0.89	0.90	0.90	0.90	0.92	0.94	0.94	0.95	0.95	0.96	0.96
Unpaved	80	0.57	0.60	0.59	0.63	0.63	0.68	0.68	0.72	0.68	0.72	0.70	0.74
Driveway/Walks	100	0.89	0.89	0.90	0.90	0.90	0.92	0.94	0.94	0.95	0.95	0.96	0.96
Roofs	90	0.73	0.73	0.73	0.75	0.75	0.77	0.78	0.80	0.80	0.82	0.81	0.85
Lawns	0	0.02	0.04	0.08	0.15	0.15	0.25	0.25	0.37	0.30	0.44	0.35	0.50

2.5 Acre Rural Lots - Comp. % Impervious Calculation			
Total Area (ac)	Area (ac) - Roofs (90%)	Area (ac) - Drives (100%)	Area (ac) - Lawns (2%)
2.50	0.068	0.046	2.39
Comp % Imperviousness	6.20%		

Roads w/ Roadside Ditches - Comp. % Impervious Calculation		
Area* (ac)	Area - Ditch (5%)	Area - Roads (100%)
0.2124	0.1320	0.0804
Comp % Imperviousness	0.41	

*Area based on 250 LF roadway from CL to outside edge of roadside ditch
 The above conservatively rounded to 45%.

Church Site - Comp. % Impervious Calculation				
Total Area (ac)	Area (ac) - Roofs (90%)	Area (ac) - Paved (100%)	Area (ac) - Gravel (80%)	Area (ac) - Lawns (2%)
4.88	0.30	1.01	0.22	3.35
Comp % Imperviousness	31.21%			

*Area based on Church site comprising of lot 38 and lot 39
 The above conservatively rounded to 35%.

**STANDARD FORM SF-2
TIME OF CONCENTRATION**

Subdivision: Saddlehorn Ranch Filing 3
Location: El Paso County

Project Name: Saddlehorn Ranch
Project No.: 25142.05
Calculated By: AAM
Checked By: TBD
Date: 6/16/23

SUB-BASIN DATA						INITIAL/OVERLAND (T _i)			TRAVEL TIME (T _t)					t _c CHECK (URBANIZED BASINS)			FINAL t _c (min)
BASIN ID	D.A. (ac)	Hydrologic Soils Group	Impervious (%)	C ₅	C ₁₀₀	L (ft)	S _o (%)	t _i (min)	L _t (ft)	S _t (%)	K	VEL. (ft/s)	t _t (min)	COMP. t _c (min)	TOTAL LENGTH (ft)	Urbanized t _c (min)	t _c (min)
C1	6.04	A	13%	0.06	0.21	300	2.1%	25.4	940	1.0%	15.0	1.5	10.4	35.8	1240.0	38.2	35.8
C2	3.35	A	24%	0.14	0.29	155	1.9%	17.5	1661	1.8%	15.0	2.0	14.0	31.5	1816.0	39.0	31.5
C3	23.44	A	9%	0.04	0.18	268	2.5%	23.2	1620	1.0%	15.0	1.5	18.0	41.2	1888.0	50.8	41.2
C4	10.94	D	18%	0.14	0.42	26	33.0%	2.8	3375	1.0%	15.0	1.5	37.5	40.3	3401.0	71.6	40.3
C5	2.35	A	20%	0.11	0.26	300	2.7%	22.3	190	2.1%	15.0	2.2	1.5	23.8	490.0	24.5	23.8
C6	3.95	A	22%	0.12	0.28	97	1.4%	15.5	997	1.0%	15.0	1.5	11.1	26.6	1094.0	36.1	26.6
C7	2.14	A	24%	0.17	0.38	52	7.5%	6.2	689	1.0%	15.0	1.5	7.7	13.9	741.0	31.1	13.9
C8	22.55	A	10%	0.05	0.19	300	1.9%	26.7	630	1.0%	15.0	1.5	7.0	33.7	930.0	34.4	33.7
C9	2.63	A	35%	0.23	0.39	136	1.2%	17.2	1374	1.5%	15.0	1.8	12.5	29.6	1510.0	33.4	29.6
C10	16.38	A	12%	0.05	0.20	147	3.7%	14.9	1406	1.5%	15.0	1.8	12.8	27.6	1553.0	42.1	27.6
D1	9.11	A	28%	0.17	0.33	200	2.0%	18.9	930	1.9%	15.0	2.1	7.5	26.4	1130.0	29.9	26.4
D2	8.49	A	13%	0.07	0.25	300	2.7%	23.1	1095	1.1%	15.0	1.6	11.6	34.7	1395.0	39.9	34.7
D3	3.21	A	8%	0.04	0.18	100	1.0%	19.2	170	1.0%	15.0	1.5	1.9	21.1	270.0	27.3	21.1
D4	10.01	D	7%	0.07	0.40	300	1.8%	26.5	1201	1.0%	15.0	1.5	13.3	39.8	1501.0	44.9	39.8
D5	9.56	D	17%	0.14	0.43	266	2.3%	21.4	1463	1.0%	15.0	1.5	16.3	37.6	1729.0	44.3	37.6
D6	0.34	A	45%	0.36	0.57	46	8.0%	4.6	332	1.0%	15.0	1.5	3.7	8.3	378.0	22.0	8.3
D7	33.94	A	15%	0.10	0.31	300	3.9%	20.0	1645	1.0%	15.0	1.5	18.3	38.3	1945.0	48.3	38.3
E1	17.12	A	7%	0.04	0.22	300	1.3%	30.4	1486	1.3%	7.0	0.8	31.0	61.4	1786.0	46.6	46.6
E2	0.37	A	45%	0.31	0.46	24	9.7%	3.3	402	1.0%	15.0	1.5	4.5	7.8	426.0	22.7	7.8
E3	0.20	A	45%	0.32	0.48	24	9.7%	3.3	185	1.1%	15.0	1.6	2.0	5.2	209.0	20.3	5.2
E4	0.68	A	3%	0.01	0.14	95	3.3%	12.9	97	1.8%	7.0	0.9	1.7	14.6	192.0	26.7	14.6
UD1	7.48	A	6%	0.03	0.16	300	1.9%	27.2	683	1.8%	7.0	0.9	12.1	39.3	983.0	33.5	33.5
UD2	9.17	A	6%	0.03	0.16	300	1.8%	27.7	445	1.9%	7.0	1.0	7.7	35.4	745.0	30.4	30.4
UD3	2.23	A	6%	0.04	0.24	300	2.0%	26.4	171	2.0%	7.0	1.0	2.9	29.3	471.0	27.0	27.0
UD4	34.90	D	2%	0.04	0.39	300	1.1%	32.2	2602	1.7%	15.0	2.0	22.2	54.3	2902.0	61.5	54.3
UD5	17.63	A	6%	0.04	0.26	300	1.7%	27.7	1230	1.5%	7.0	0.9	23.9	51.6	1530.0	41.9	41.9
OS1	2.37	A	58%	0.43	0.56	59	2.0%	7.4	1216	1.1%	15.0	1.6	12.9	20.3	1275.0	27.5	20.3
OS2	0.70	A	31%	0.20	0.35	59	3.3%	8.5	421	1.0%	15.0	1.5	4.7	13.1	480.0	25.9	13.1
OS3	2.28	A	60%	0.45	0.58	66	8.5%	4.7	1326	1.0%	15.0	1.5	14.7	19.5	1392.0	28.5	19.5
OS4	1.08	D	55%	0.44	0.63	66	8.5%	4.8	636	1.0%	15.0	1.5	7.1	11.8	702.0	23.1	11.8
OS5	2.92	A	23%	0.17	0.42	55	3.4%	8.3	857	1.0%	15.0	1.5	9.5	17.8	912.0	33.7	17.8

STANDARD FORM SF-3
STORM DRAINAGE SYSTEM DESIGN
(RATIONAL METHOD PROCEDURE)

Subdivision: Saddlehorn Ranch Filing 3
Location: El Paso County
Design Storm: 5-Year

Project Name: Saddlehorn Ranch
Project No.: 25142.05
Calculated By: AAM
Checked By: TBD
Date: 6/16/23

STREET	Design Point	DIRECT RUNOFF							TOTAL RUNOFF				SWALE			PIPE				TRAVEL TIME			REMARKS
		Basin ID	Area (Ac)	Runoff Coeff.	t _c (min)	C*A (Ac)	I (in/hr)	Q (cfs)	t _c (min)	C*A (ac)	I (in/hr)	Q (cfs)	Q _{street} (cfs)	C*A (ac)	Slope (%)	Q _{pipe} (cfs)	C*A (ac)	Slope (%)	Pipe Size (inches)	Length (ft)	Velocity (fps)	t _t (min)	
	OS1	OS1	2.37	0.43	20.3	1.01	3.07	3.1				3.1	1.01	2.5					114	3.2	0.6	Roadside Swale Swale conveyance to DP 1.0	
	1	C1	6.04	0.06	35.8	0.39	2.22	0.9				0.9	0.39	1.0					0	2.0	0.0	Roadside Swale Swale conveyance to DP 1.0	
	1.0							35.8	1.40	2.22	3.1	3.1	1.40	2.1					752	2.9	4.3	Sum of DP OS1 and DP 1 Swale conveyance to DP 1.1	
	2	C2	3.35	0.14	31.5	0.46	2.41	1.1				1.1	0.46	1.0					0	2.0	0.0	Roadside Swale Swale conveyance to DP 1.1	
	3	C3	23.44	0.04	41.2	0.91	2.01	1.8				1.8	0.91	1.0					0	2.0	0.0	Roadside Swale Swale conveyance to DP 1.1	
	OS2	OS2	0.70	0.20	13.1	0.14	3.72	0.5				0.5	0.14	1.0					0	2.0	0.0	Roadside Swale Swale conveyance to DP 1.1	
	1.1							41.2	2.91	2.01	5.8	5.8	2.91	1.0					1716	2.0	14.3	Sum of DP 1.0, DP 2, DP OS2 & DP 3 Swale conveyance to DP 1.2	
	4	C4	10.94	0.14	40.3	1.58	2.04	3.2				3.2	1.58	0.5					0	1.4	0.0	Roadside Swale Swale conveyance to DP 1.2	
	1.2							55.5	4.49	1.56	7.0	7.0	4.49	1.0					344	2.0	2.9	Sum of DP 1.1 and DP 4 Swale conveyance to DP 1.3	
	5	C5	2.35	0.11	23.8	0.26	2.83	0.7				0.7	0.26	1.0					0	2.0	0.0	Roadside Swale Swale conveyance to DP 1.3	
	1.3							58.3	4.75	1.48	7.0	7.0	4.75	1.0					1147	2.0	9.6	Sum of DP 1.2 and DP 5 Culvert conveyance to DP 1.4	
	6	C6	3.95	0.12	26.6	0.49	2.66	1.3				1.3	0.49	1.0					0	2.0	0.0	Roadside Swale Swale conveyance to DP 1.4	
	1.4							58.3	5.24	1.48	7.8				7.8	5.24	1.0	24	59	6.5	0.2	Sum of DP 1.3 and DP 6 Culvert conveyance to DP 1.6	
	7	C7	2.14	0.17	13.9	0.36	3.64	1.3				1.3	0.36	1.0					1214	2.0	10.1	Roadside Swale Swale conveyance to DP 1.5	
	8	C8	22.55	0.05	33.7	1.04	2.31	2.4				2.4	1.04	1.0					0	2.0	0.0	Roadside Swale Swale conveyance to DP 1.5	
	1.5							33.7	1.40	2.31	3.2	3.2	1.40	1.0					278	2.0	2.3	Sum of DP 7 and DP 8 Swale conveyance to DP 1.6	
	9	C9	2.63	0.23	29.6	0.60	2.50	1.5				1.5	0.60	1.0					0	2.0	0.0	Roadside Swale Swale conveyance to DP 1.6	
	1.6							58.5	7.24	1.48	10.7	10.7	7.24	0.75					388	1.7	3.7	Sum of DP 1.4, DP 1.5, and DP 9 Swale/ Pond conveyance to DP 1.7	
	10	C10	16.38	0.05	27.6	0.90	2.61	2.3				2.3	0.90	1.0					0	2.0	0.0	Proposed Pond C, future Filing 4 Lots, and Filing 4 roadways Overland flow, future road swales, and pond conveyance to DP 1.7	
	1.7							62.2	8.14	1.39	11.3											Sum of DP 1.6 and DP 10 Outlet structure release into Drainageway MS-06	
	11	D1	9.11	0.17	26.4	1.56	2.67	4.2				4.2	1.56	1.0					682	2.0	5.7	Roadside Swale Swale conveyance to DP 2.0	

STANDARD FORM SF-3
STORM DRAINAGE SYSTEM DESIGN
(RATIONAL METHOD PROCEDURE)

Subdivision: Saddlehorn Ranch Filing 3
Location: El Paso County
Design Storm: 100-Year

Project Name: Saddlehorn Ranch
Project No.: 25142.05
Calculated By: AAM
Checked By: TBD
Date: 6/16/23

STREET	Design Point	DIRECT RUNOFF							TOTAL RUNOFF				SWALE			PIPE				TRAVEL TIME			REMARKS
		Basin ID	Area (ac)	Runoff Coeff.	t _c (min)	C*A (ac)	I (in/hr)	Q (cfs)	t _c (min)	C*A (ac)	I (in/hr)	Q (cfs)	Q _{swale} (cfs)	C*A (ac)	Slope (%)	Q _{pipe} (cfs)	C*A (ac)	Slope (%)	Pipe Size (inches)	Length (ft)	Velocity (fps)	t _t (min)	
	OS1	OS1	2.37	0.56	20.3	1.33	5.15	6.8					6.8	1.33	2.5					114	3.2	0.6	Roadside Swale Swale conveyance to DP 1.0
	1	C1	6.04	0.21	35.8	1.28	3.72	4.8					4.8	1.28	1.0					0	2.0	0.0	Roadside Swale Swale conveyance to DP 1.0
	1.0							35.8	2.61	3.72	9.7	9.7	2.61	2.1						752	2.9	4.3	Sum of DP OS1 and DP 1 Swale conveyance to DP 1.1
	2	C2	3.35	0.29	31.5	0.98	4.04	4.0					4.0	0.98	1.0					0	2.0	0.0	Roadside Swale Swale conveyance to DP 1.1
	3	C3	23.44	0.18	41.2	4.20	3.37	14.1					14.1	4.20	1.0					0	2.0	0.0	Roadside Swale Swale conveyance to DP 1.1
	OS2	OS2	0.70	0.35	13.1	0.25	6.25	1.6					1.6	0.25	1.0					0	2.0	0.0	Roadside Swale Swale conveyance to DP 1.1
	1.1							41.2	8.04	3.37	27.1	27.1	8.04	1.0						1716	2.0	14.3	Sum of DP 1.0, DP 2, DP OS 2 & DP 3 Swale conveyance to DP 1.2
	4	C4	10.94	0.42	40.3	4.54	3.42	15.5					15.5	4.54	0.5					0	1.4	0.0	Roadside Swale Swale conveyance to DP 1.2
	1.2							55.5	12.58	2.61	32.9	32.9	12.58	1.0						344	2.0	2.9	Sum of DP 1.1 and DP 4 Swale conveyance to DP 1.3
	5	C5	2.35	0.26	23.8	0.62	4.75	2.9					2.9	0.62	1.0					0	2.0	0.0	Roadside Swale Swale conveyance to DP 1.3
	1.3							58.3	13.20	2.49	32.8	32.8	13.20	1.0						1147	2.0	9.6	Sum of DP 1.2 and DP 5 Culvert conveyance to DP 1.4
	6	C6	3.95	0.28	26.6	1.11	4.46	5.0					5.0	1.11	1.0					0	2.0	0.0	Roadside Swale Swale conveyance to DP 1.4
	1.4							58.3	14.31	2.49	35.6				35.6	14.31	1.0	24	59	11.3	0.1	Sum of DP 1.3 and DP 6 Culvert conveyance to DP 1.6	
	7	C7	2.14	0.38	13.9	0.81	6.10	4.9					4.9	0.81	1.0					1214	2.0	10.1	Roadside Swale Swale conveyance to DP 1.5
	8	C8	22.55	0.19	33.7	4.24	3.87	16.4					16.4	4.24	1.0					0	2.0	0.0	Roadside Swale Swale conveyance to DP 1.5
	1.5							33.7	5.05	3.87	19.6	19.6	5.05	1.0						278	2.0	2.3	Sum of DP 7 and DP 8 Swale conveyance to DP 1.6
	9	C9	2.63	0.39	29.6	1.02	4.19	4.3					4.3	1.02	1.0					0	2.0	0.0	Roadside Swale Swale conveyance to DP 1.6
	1.6							58.4	20.38	2.48	50.6	50.6	20.38	0.75						388	1.7	3.7	Sum of DP 1.4, DP 1.5, and DP 9 Swale/ Pond conveyance to DP 1.7
	10	C10	16.38	0.20	27.6	3.28	4.37	14.3					14.3	3.28	1.0					0	2.0	0.0	Proposed Pond C, future Filing 4 Lots, and Filing 4 roadways Overland flow, future road swales, and pond conveyance to DP 1.7
	1.7							58.4	23.66	2.48	58.8												Sum of DP 1.6 and DP 10 Outlet structure release into Drainageway MS-06
	11	D1	9.11	0.33	26.4	3.01	4.49	13.5					13.5	3.01	1.0					682	2.0	5.7	Roadside Swale Swale conveyance to DP 2.0

Culvert Report

CALCULATED FLOWS FOR BASIN CH2 (APPENDIX B):
 Q5 = 0.9 CFS; Q100 = 2.5 CFS) ARE WELL BELOW THE ESTIMATED
 FDR FLOWS IN THIS CALCULATION

Culvert CH2 (Q5=2.81 cfs, Q100=9.05 cfs)

Invert Elev Dn (ft)	=	6755.18
Pipe Length (ft)	=	62.61
Slope (%)	=	2.78
Invert Elev Up (ft)	=	6756.92
Rise (in)	=	18.0
Shape	=	Circular
Span (in)	=	18.0
No. Barrels	=	1
n-Value	=	0.013
Culvert Type	=	Circular Concrete
Culvert Entrance	=	Square edge w/headwall (C)
Coeff. K,M,c,Y,k	=	0.0098, 2, 0.0398, 0.67, 0.5

Embankment

Top Elevation (ft)	=	6761.00
Top Width (ft)	=	45.00
Crest Width (ft)	=	0.00

Calculations

Qmin (cfs)	=	2.81
Qmax (cfs)	=	9.05
Tailwater Elev (ft)	=	(dc+D)/2

Highlighted

Qtotal (cfs)	=	9.05
Qpipe (cfs)	=	9.05
Qovertop (cfs)	=	0.00
Veloc Dn (ft/s)	=	5.46
Veloc Up (ft/s)	=	6.16
HGL Dn (ft)	=	6756.51
HGL Up (ft)	=	6758.08
Hw Elev (ft)	=	6758.95
Hw/D (ft)	=	1.35
Flow Regime	=	Inlet Control

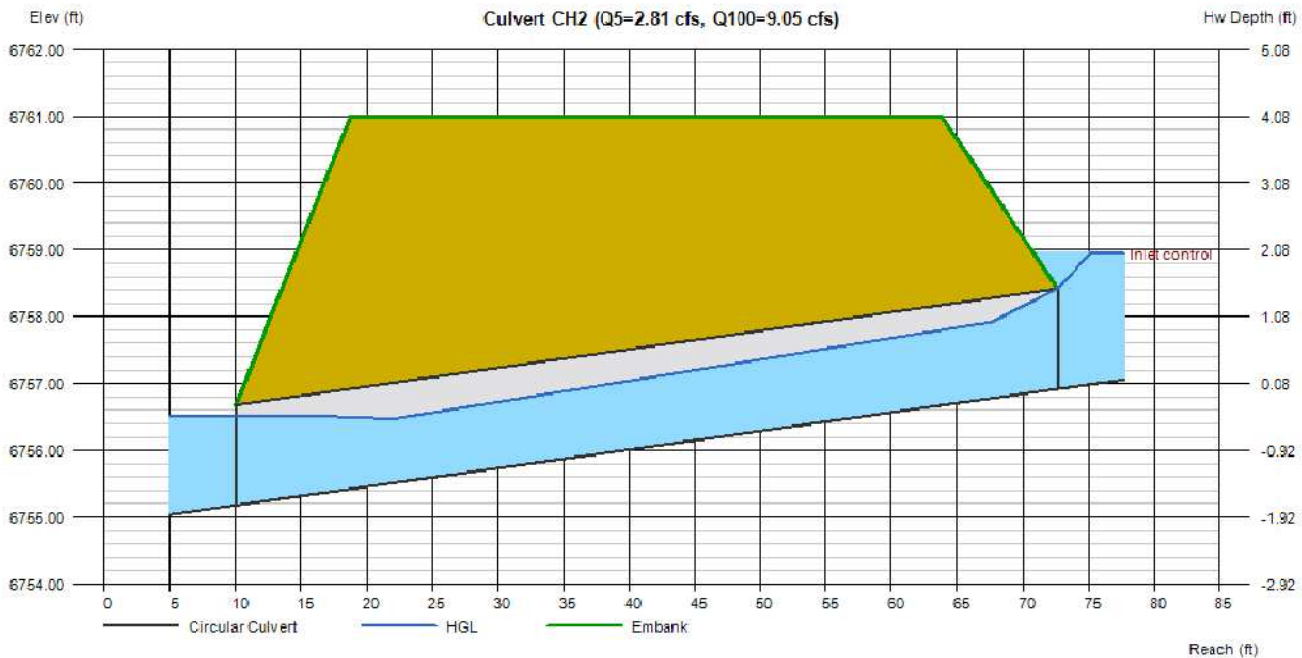

This culvert will be constructed by a different contractor alongside construction of the church site. The estimated flow being captured by this culvert is estimated to be 67% of the flow generated by Basin D1. This flow estimate is larger than what will actually flow to this culvert given where the culvert is placed in relation to the basin.

Pond Summary Table

Pond C

Tributary Sub-basin	Area (acres)	Percent Impervious
C1	6.04	13.1%
C2	3.35	23.6%
C3	23.44	8.9%
C4	10.94	18.3%
C5	2.35	19.9%
C6	3.95	21.8%
C7	2.14	24.3%
C8	22.55	10.0%
C9	2.63	35.4%
C10	16.38	11.5%
OS1	2.37	57.8%
OS2	0.70	31.4%
Total	96.84	14.4%

Pond D

Tributary Sub-basin	Area (acres)	Percent Impervious
D1	9.11	28.1%
D2	8.49	13.0%
D3	3.21	8.5%
D4	10.01	6.9%
D5	9.56	17.5%
D6	0.34	45.0%
D7	33.94	14.7%
OS3	2.28	60.0%
OS4	1.08	54.6%
Total	78.02	17.2%

Pond E

Tributary Sub-basin	Area (acres)	Percent Impervious
E1	17.12	7.0%
E2	0.37	45.0%
E3	0.20	45.0%
E4	0.68	3.2%
Total	18.37	8.1%

SADDLEHORN RANCH - FILING 3

PROPOSED DRAINAGE MAP

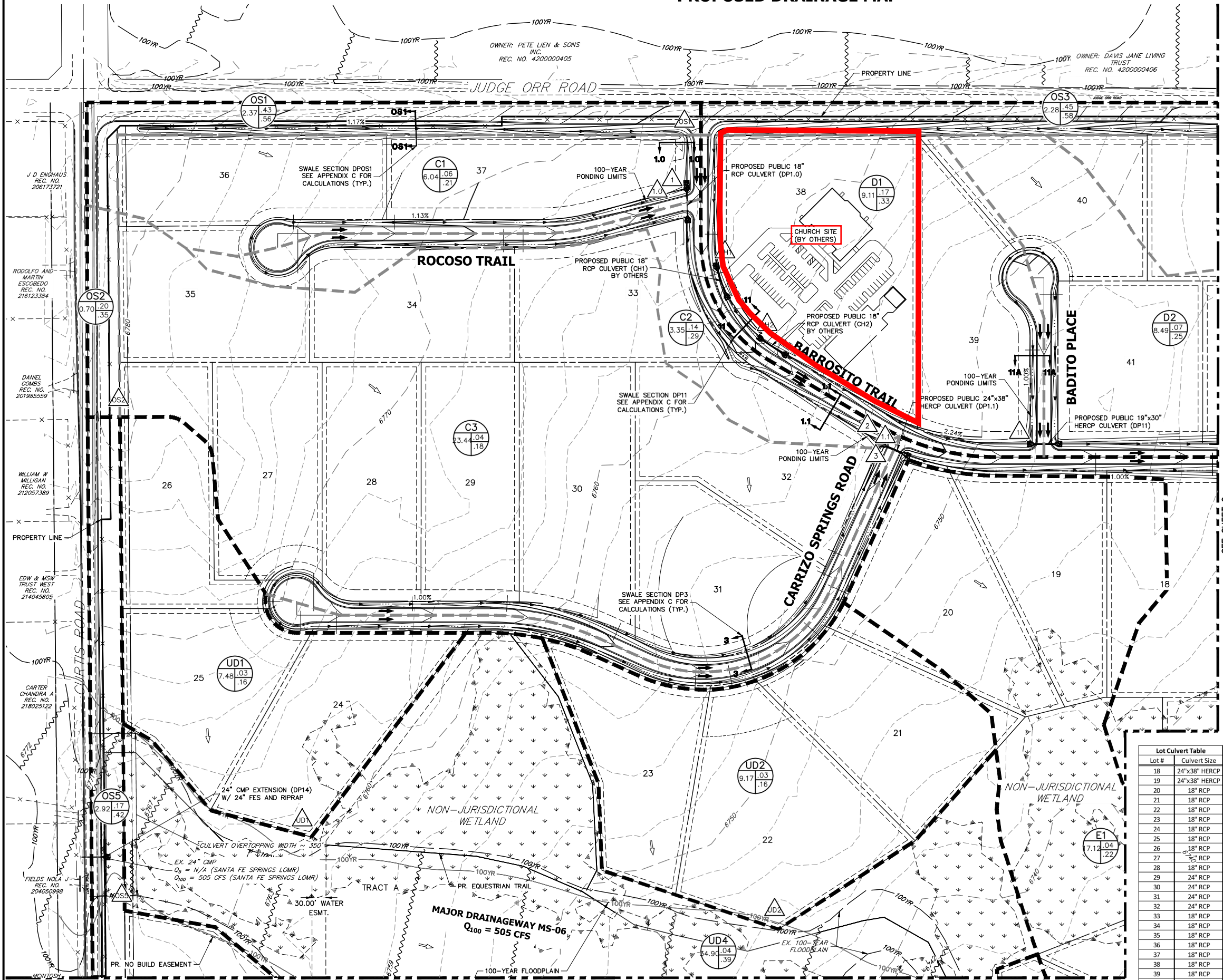
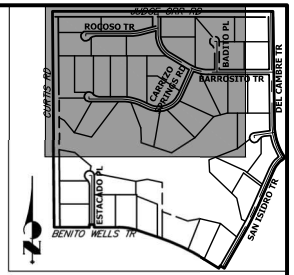

FILING 3 - SUB-BASIN SUMMARY TABLE

Tributary Sub-basin	Area (acres)	Percent Impervious	C _s	C ₁₀₀	t _c (min)	Q _s (cfs)	Q ₁₀₀ (cfs)
C1	6.04	13%	0.06	0.21	35.8	0.9	4.8
C2	3.35	24%	0.14	0.29	31.5	1.1	4.0
C3	23.44	9%	0.04	0.18	41.2	1.8	14.1
C4	10.94	18%	0.14	0.42	40.3	3.2	15.5
C5	2.35	20%	0.11	0.26	23.8	0.7	2.9
C6	3.95	22%	0.12	0.28	26.6	1.3	5.0
C7	2.14	24%	0.17	0.38	13.9	1.3	4.9
C8	22.55	10%	0.05	0.19	33.7	2.4	16.4
C9	2.63	35%	0.23	0.39	29.6	1.5	4.3
C10	16.38	12%	0.05	0.20	27.6	2.3	14.3
D1	9.11	28%	0.17	0.33	26.4	4.2	13.5
D2	8.49	13%	0.07	0.25	34.7	1.4	8.2
D3	3.21	8%	0.04	0.18	21.1	0.4	2.8
D4	10.01	7%	0.07	0.40	39.8	1.5	13.9
D5	9.56	17%	0.14	0.43	37.6	3.0	14.9
D6	0.34	45%	0.36	0.57	8.3	0.5	1.4
D7	33.94	15%	0.10	0.31	38.3	6.9	37.3
E1	17.12	7%	0.04	0.22	46.6	1.3	11.8
E2	0.37	45%	0.31	0.46	7.8	0.5	1.3
E3	0.20	45%	0.32	0.48	5.2	0.3	0.8
E4	0.68	3%	0.01	0.14	14.6	0.04	0.6
UD1	7.48	6%	0.03	0.16	33.5	0.4	4.6
UD2	9.17	6%	0.03	0.16	30.4	0.6	6.0
UD3	2.23	6%	0.04	0.24	27.0	0.2	2.3
UD4	34.90	2%	0.04	0.39	54.3	2.2	36.5
UD5	17.63	6%	0.04	0.26	41.9	1.5	15.4
OS1	2.37	58%	0.43	0.56	20.3	3.1	6.8
OS2	0.70	31%	0.20	0.35	13.1	0.5	1.6
OS3	2.28	60%	0.45	0.58	19.5	3.2	6.9
OS4	1.08	55%	0.44	0.63	11.8	1.9	4.4
OS5	2.92	23%	0.17	0.42	17.8	1.7	6.7
F1	1.35	40%	0.27	0.43	12.7	1.4	3.6
F2	7.67	11%	0.05	0.20	35.0	0.9	5.7
F3	5.44	24%	0.20	0.48	31.1	2.6	10.6
F4	2.93	45%	0.34	0.52	32.3	2.3	6.0

FILING 3 - DESIGN POINT SUMMARY TABLE

Design Point	Q _s (cfs)	Q ₁₀₀ (cfs)
1	0.9	4.8
2	1.1	4.0
3	1.8	14.1
4	3.2	15.5
5	0.7	2.9
6	1.3	5.0
7	1.3	4.9
8	2.4	16.4
9	1.5	4.3
10	2.3	14.3
11	4.2	13.5
12	1.4	8.2
13	0.4	2.8
14	1.5	13.9
15	3.0	14.9
16	0.5	1.4
17	6.9	37.3
21	1.3	11.8
22	0.5	1.3
23	0.3	0.8
24	0.04	0.6
25	0.90	5.7
OS1	3.1	6.8
OS2	0.5	1.6
OS3	3.2	6.9
OS4	1.9	4.4
OS5	1.7	6.7
UD1	0.4	4.6
UD2	0.6	6.0
UD3	0.2	2.3
UD4	2.2	36.5
UD5	1.5	15.4
1.0	3.1	9.7
1.1	5.8	27.1
1.2	7.0	32.9
1.3	7.0	32.8
1.4	7.8	35.6
1.5	3.2	19.6
1.6	10.7	50.6
1.7	11.3	58.8
2.0	5.0	19.6
2.1	3.4	9.5
2.2	4.3	11.3
2.3	6.7	34.1
2.4	10.7	55.5
2.5	15.0	83.6
3.0	1.6	12.6
3.1	1.5	12.6

LEGEND

- I.D.** BASIN DESIGNATION
- A/B/C** I.D.: BASIN IDENTIFIER
- A**: BASIN AREA
- B**: C_s
- C**: C₁₀₀
- X** DESIGN POINT
- MAJOR BASIN DELINEATION
- - -** SUB-BASIN DELINEATION
- 6700-** EXISTING INDEX CONTOURS
- - -6700-** EXISTING INTERMEDIATE CONTOURS
- 6700-** PROPOSED INDEX CONTOURS
- - -6700-** PROPOSED INTERMEDIATE CONTOURS
- EXISTING FLOW DIRECTION
- PROPOSED FLOW DIRECTION
- HP** PROPOSED HIGH POINT
- LP** PROPOSED LOW POINT
- WETLANDS HATCH** WETLANDS HATCH
- SETBACK LINE

100 50 0 100 200
ORIGINAL SCALE: 1" = 100'

Lot Culvert Table

Lot #	Culvert Size
18	24"x38" HERCP
19	24"x38" HERCP
20	18" RCP
21	18" RCP
22	18" RCP
23	18" RCP
24	18" RCP
25	18" RCP
26	18" RCP
27	18" RCP
28	18" RCP
29	24" RCP
30	24" RCP
31	24" RCP
32	24" RCP
33	18" RCP
34	18" RCP
35	18" RCP
36	18" RCP
37	18" RCP
38	18" RCP
39	18" RCP
40	19"x30" HERCP
41	18" RCP
42	18" RCP

SADDLEHORN RANCH - FILING 3
PROPOSED DRAINAGE MAP
JOB NO. 25142.05
5/15/24
SHEET 1 OF 4

J-R ENGINEERING
A Westrian Company

Centennial 303-740-9333 • Colorado Springs 719-593-2593
Fort Collins 970-491-9888 • www.jrengineering.com

SEE SHEET 4

SEE SHEET 2

SADDLEHORN RANCH - FILING 3

PROPOSED DRAINAGE MAP

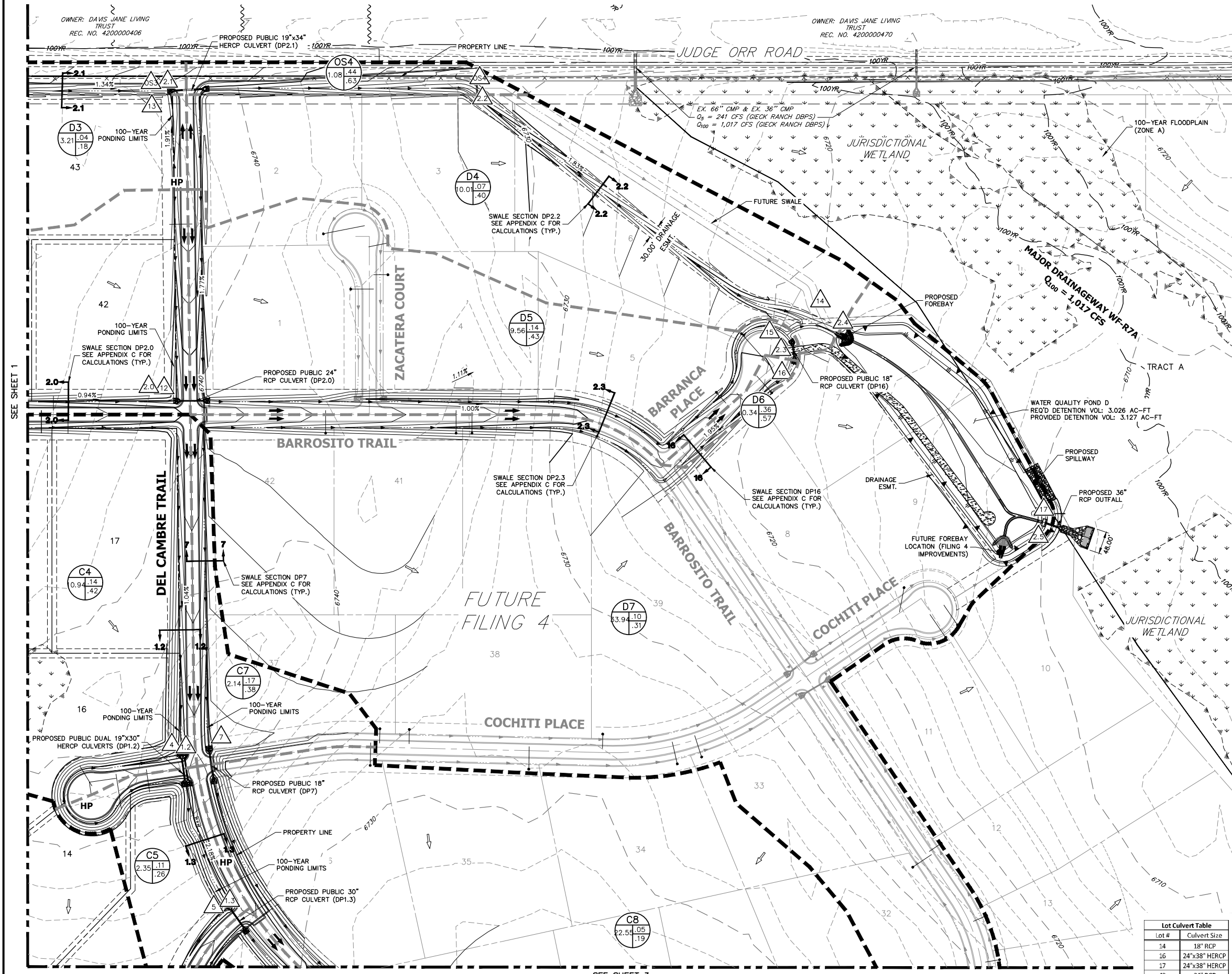

FILING 3 - SUB-BASIN SUMMARY TABLE

Tributary Sub-basin	Area (acres)	Percent Impervious	C _s	C ₁₀₀	t _c (min)	Q _s (cfs)	Q ₁₀₀ (cfs)
C1	6.04	13%	0.06	0.21	35.8	0.9	4.8
C2	3.35	24%	0.14	0.29	31.5	1.1	4.0
C3	23.44	9%	0.04	0.18	41.2	1.8	14.1
C4	10.94	18%	0.14	0.42	40.3	3.2	15.5
C5	2.35	20%	0.11	0.26	23.8	0.7	2.9
C6	3.95	22%	0.12	0.28	26.6	1.3	5.0
C7	2.14	24%	0.17	0.38	13.9	1.3	4.9
C8	22.55	10%	0.05	0.19	33.7	2.4	16.4
C9	2.63	35%	0.23	0.39	29.6	1.5	4.3
C10	16.38	12%	0.05	0.20	27.6	2.3	14.3
D1	9.11	28%	0.17	0.33	26.4	4.2	13.5
D2	8.49	13%	0.07	0.25	34.7	1.4	8.2
D3	3.21	8%	0.04	0.18	21.1	0.4	2.8
D4	10.01	7%	0.07	0.40	39.8	1.5	13.9
D5	9.56	17%	0.14	0.43	37.6	3.0	14.9
D6	0.34	45%	0.36	0.57	8.3	0.5	1.4
D7	33.94	15%	0.10	0.31	38.3	6.9	37.3
E1	17.12	7%	0.04	0.22	46.6	1.3	11.8
E2	0.37	45%	0.31	0.46	7.8	0.5	1.3
E3	0.20	45%	0.32	0.48	5.2	0.3	0.8
E4	0.68	3%	0.01	0.14	14.6	0.04	0.6
UD1	7.48	6%	0.03	0.16	33.5	0.4	4.6
UD2	9.17	6%	0.03	0.16	30.4	0.6	6.0
UD3	2.23	6%	0.04	0.24	27.0	0.2	2.3
UD4	34.90	2%	0.04	0.39	54.3	2.2	36.5
UD5	17.63	6%	0.04	0.26	41.9	1.5	15.4
OS1	2.37	58%	0.43	0.56	20.3	3.1	6.8
OS2	0.70	31%	0.20	0.35	13.1	0.5	1.6
OS3	2.28	60%	0.45	0.58	19.5	3.2	6.9
OS4	1.08	55%	0.44	0.63	11.8	1.9	4.4
OS5	2.92	23%	0.17	0.42	17.8	1.7	6.7
F1	1.35	40%	0.27	0.43	12.7	1.4	3.6
F2	7.67	11%	0.05	0.20	35.0	0.9	5.7
F3	5.44	24%	0.20	0.48	31.1	2.6	10.6
F4	2.93	45%	0.34	0.52	32.3	2.3	6.0

FILING 3 - DESIGN POINT SUMMARY TABLE

Design Point	Q _s (cfs)	Q ₁₀₀ (cfs)
1	0.9	4.8
2	1.1	4.0
3	1.8	14.1
4	3.2	15.5
5	0.7	2.9
6	1.3	5.0
7	1.3	4.9
8	2.4	16.4
9	1.5	4.3
10	2.3	14.3
11	4.2	13.5
12	1.4	8.2
13	0.4	2.8
14	1.5	13.9
15	3.0	14.9
16	0.5	1.4
17	6.9	37.3
21	1.3	11.8
22	0.5	1.3
23	0.3	0.8
24	0.04	0.6
25	0.90	5.7
OS1	3.1	6.8
OS2	0.5	1.6
OS3	3.2	6.9
OS4	1.9	4.4
OS5	1.7	6.7
UD1	0.4	4.6
UD2	0.6	6.0
UD3	0.2	2.3
UD4	2.2	36.5
UD5	1.5	15.4
1.0	3.1	9.7
1.1	5.8	27.1
1.2	7.0	32.9
1.3	7.0	32.8
1.4	7.8	35.6
1.5	3.2	19.6
1.6	10.7	50.6
1.7	11.3	58.8
2.0	5.0	19.6
2.1	3.4	9.5
2.2	4.3	11.3
2.3	6.7	34.1
16	24"x38" HERCP	
17	24"x38" HERCP	
43	24" RCP	
44	18" RCP	

LEGEND

- I.D. BASIN DESIGNATION
- I.D.: BASIN IDENTIFIER
- A: BASIN AREA
- B: C_s
- C: C₁₀₀
- △ DESIGN POINT
- MAJOR BASIN DELINEATION
- SUB-BASIN DELINEATION
- 6700- EXISTING INDEX CONTOURS
- - - - - EXISTING INTERMEDIATE CONTOURS
- 6700- PROPOSED INDEX CONTOURS
- - - - - PROPOSED INTERMEDIATE CONTOURS
- EXISTING FLOW DIRECTION
- PROPOSED FLOW DIRECTION
- HP PROPOSED HIGH POINT
- LP PROPOSED LOW POINT
- WETLANDS HATCH
- SETBACK LINE

100 50 0 100 200
ORIGINAL SCALE: 1" = 100'

SADDLEHORN RANCH - FILING 3
PROPOSED DRAINAGE MAP
JOB NO. 25142.05
5/15/24
SHEET 2 OF 4

J-R ENGINEERING
A Westrian Company

Centennial 303-740-9333 • Colorado Springs 719-593-2593
Fort Collins 970-491-9888 • www.jrengineering.com

SEE SHEET 1

SEE SHEET 3

APPENDIX B
HYDROLOGIC CALCULATIONS

Table 6-6. Runoff Coefficients for Rational Method
(Source: UDFCD 2001)

Land Use or Surface Characteristics	Percent Impervious	Runoff Coefficients											
		2-year		5-year		10-year		25-year		50-year		100-year	
		HSG A&B	HSG C&D	HSG A&B	HSG C&D	HSG A&B	HSG C&D	HSG A&B	HSG C&D	HSG A&B	HSG C&D	HSG A&B	HSG C&D
Business													
Commercial Areas	95	0.79	0.80	0.81	0.82	0.83	0.84	0.85	0.87	0.87	0.88	0.88	0.89
Neighborhood Areas	70	0.45	0.49	0.49	0.53	0.53	0.57	0.58	0.62	0.60	0.65	0.62	0.68
Residential													
1/8 Acre or less	65	0.41	0.45	0.45	0.49	0.49	0.54	0.54	0.59	0.57	0.62	0.59	0.65
1/4 Acre	40	0.23	0.28	0.30	0.35	0.36	0.42	0.42	0.50	0.46	0.54	0.50	0.58
1/3 Acre	30	0.18	0.22	0.25	0.30	0.32	0.38	0.39	0.47	0.43	0.52	0.47	0.57
1/2 Acre	25	0.15	0.20	0.22	0.28	0.30	0.36	0.37	0.46	0.41	0.51	0.46	0.56
1 Acre	20	0.12	0.17	0.20	0.26	0.27	0.34	0.35	0.44	0.40	0.50	0.44	0.55
Industrial													
Light Areas	80	0.57	0.60	0.59	0.63	0.63	0.66	0.66	0.70	0.68	0.72	0.70	0.74
Heavy Areas	90	0.71	0.73	0.73	0.75	0.75	0.77	0.78	0.80	0.80	0.82	0.81	0.83
Parks and Cemeteries	7	0.05	0.09	0.12	0.19	0.20	0.29	0.30	0.40	0.34	0.46	0.39	0.52
Playgrounds	13	0.07	0.13	0.16	0.23	0.24	0.31	0.32	0.42	0.37	0.48	0.41	0.54
Railroad Yard Areas	40	0.23	0.28	0.30	0.35	0.36	0.42	0.42	0.50	0.46	0.54	0.50	0.58
Undeveloped Areas													
Historic Flow Analysis-- Greenbelts, Agriculture	2	0.03	0.05	0.09	0.16	0.17	0.26	0.26	0.38	0.31	0.45	0.36	0.51
Pasture/Meadow	0	0.02	0.04	0.08	0.15	0.15	0.25	0.25	0.37	0.30	0.44	0.35	0.50
Forest	0	0.02	0.04	0.08	0.15	0.15	0.25	0.25	0.37	0.30	0.44	0.35	0.50
Exposed Rock	100	0.89	0.89	0.90	0.90	0.92	0.92	0.94	0.94	0.95	0.95	0.96	0.96
Offsite Flow Analysis (when landuse is undefined)	45	0.26	0.31	0.32	0.37	0.38	0.44	0.44	0.51	0.48	0.55	0.51	0.59
Streets													
Paved	100	0.89	0.89	0.90	0.90	0.92	0.92	0.94	0.94	0.95	0.95	0.96	0.96
Gravel	80	0.57	0.60	0.59	0.63	0.63	0.66	0.66	0.70	0.68	0.72	0.70	0.74
Drive and Walks	100	0.89	0.89	0.90	0.90	0.92	0.92	0.94	0.94	0.95	0.95	0.96	0.96
Roofs	90	0.71	0.73	0.73	0.75	0.75	0.77	0.78	0.80	0.80	0.82	0.81	0.83
Lawns	0	0.02	0.04	0.08	0.15	0.15	0.25	0.25	0.37	0.30	0.44	0.35	0.50

3.2 Time of Concentration

One of the basic assumptions underlying the Rational Method is that runoff is a function of the average rainfall rate during the time required for water to flow from the hydraulically most remote part of the drainage area under consideration to the design point. However, in practice, the time of concentration can be an empirical value that results in reasonable and acceptable peak flow calculations.

For urban areas, the time of concentration (t_c) consists of an initial time or overland flow time (t_i) plus the travel time (t_r) in the storm sewer, paved gutter, roadside drainage ditch, or drainage channel. For non-urban areas, the time of concentration consists of an overland flow time (t_i) plus the time of travel in a concentrated form, such as a swale or drainageway. The travel portion (t_r) of the time of concentration can be estimated from the hydraulic properties of the storm sewer, gutter, swale, ditch, or drainageway. Initial time, on the other hand, will vary with surface slope, depression storage, surface cover, antecedent rainfall, and infiltration capacity of the soil, as well as distance of surface flow. The time of concentration is represented by Equation 6-7 for both urban and non-urban areas.

$$t_c = t_i + t_t \quad (\text{Eq. 6-7})$$

Where:

t_c = time of concentration (min)

t_i = overland (initial) flow time (min)

t_t = travel time in the ditch, channel, gutter, storm sewer, etc. (min)

3.2.1 Overland (Initial) Flow Time

The overland flow time, t_i , may be calculated using Equation 6-8.

$$t_i = \frac{0.395(1.1 - C_5)\sqrt{L}}{S^{0.33}} \quad (\text{Eq. 6-8})$$

Where:

t_i = overland (initial) flow time (min)

C_5 = runoff coefficient for 5-year frequency (see Table 6-6)

L = length of overland flow (300 ft maximum for non-urban land uses, 100 ft maximum for urban land uses)

S = average basin slope (ft/ft)

Note that in some urban watersheds, the overland flow time may be very small because flows quickly concentrate and channelize.

3.2.2 Travel Time

For catchments with overland and channelized flow, the time of concentration needs to be considered in combination with the travel time, t_t , which is calculated using the hydraulic properties of the swale, ditch, or channel. For preliminary work, the overland travel time, t_t , can be estimated with the help of Figure 6-25 or Equation 6-9 (Guo 1999).

$$V = C_v S_w^{0.5} \quad (\text{Eq. 6-9})$$

Where:

V = velocity (ft/s)

C_v = conveyance coefficient (from Table 6-7)

S_w = watercourse slope (ft/ft)

Table 6-7. Conveyance Coefficient, C_v

Type of Land Surface	C_v
Heavy meadow	2.5
Tillage/field	5
Riprap (not buried)*	6.5
Short pasture and lawns	7
Nearly bare ground	10
Grassed waterway	15
Paved areas and shallow paved swales	20

* For buried riprap, select C_v value based on type of vegetative cover.

The travel time is calculated by dividing the flow distance (in feet) by the velocity calculated using Equation 6-9 and converting units to minutes.

The time of concentration (t_c) is then the sum of the overland flow time (t_i) and the travel time (t_t) per Equation 6-7.

3.2.3 First Design Point Time of Concentration in Urban Catchments

Using this procedure, the time of concentration at the first design point (typically the first inlet in the system) in an urbanized catchment should not exceed the time of concentration calculated using Equation 6-10. The first design point is defined as the point where runoff first enters the storm sewer system.

$$t_c = \frac{L}{180} + 10 \quad (\text{Eq. 6-10})$$

Where:

t_c = maximum time of concentration at the first design point in an urban watershed (min)

L = waterway length (ft)

Equation 6-10 was developed using the rainfall-runoff data collected in the Denver region and, in essence, represents regional “calibration” of the Rational Method. Normally, Equation 6-10 will result in a lesser time of concentration at the first design point and will govern in an urbanized watershed. For subsequent design points, the time of concentration is calculated by accumulating the travel times in downstream drainageway reaches.

3.2.4 Minimum Time of Concentration

If the calculations result in a t_c of less than 10 minutes for undeveloped conditions, it is recommended that a minimum value of 10 minutes be used. The minimum t_c for urbanized areas is 5 minutes.

3.2.5 Post-Development Time of Concentration

As Equation 6-8 indicates, the time of concentration is a function of the 5-year runoff coefficient for a drainage basin. Typically, higher levels of imperviousness (higher 5-year runoff coefficients) correspond to shorter times of concentration, and lower levels of imperviousness correspond to longer times of

Figure 6-5. Colorado Springs Rainfall Intensity Duration Frequency

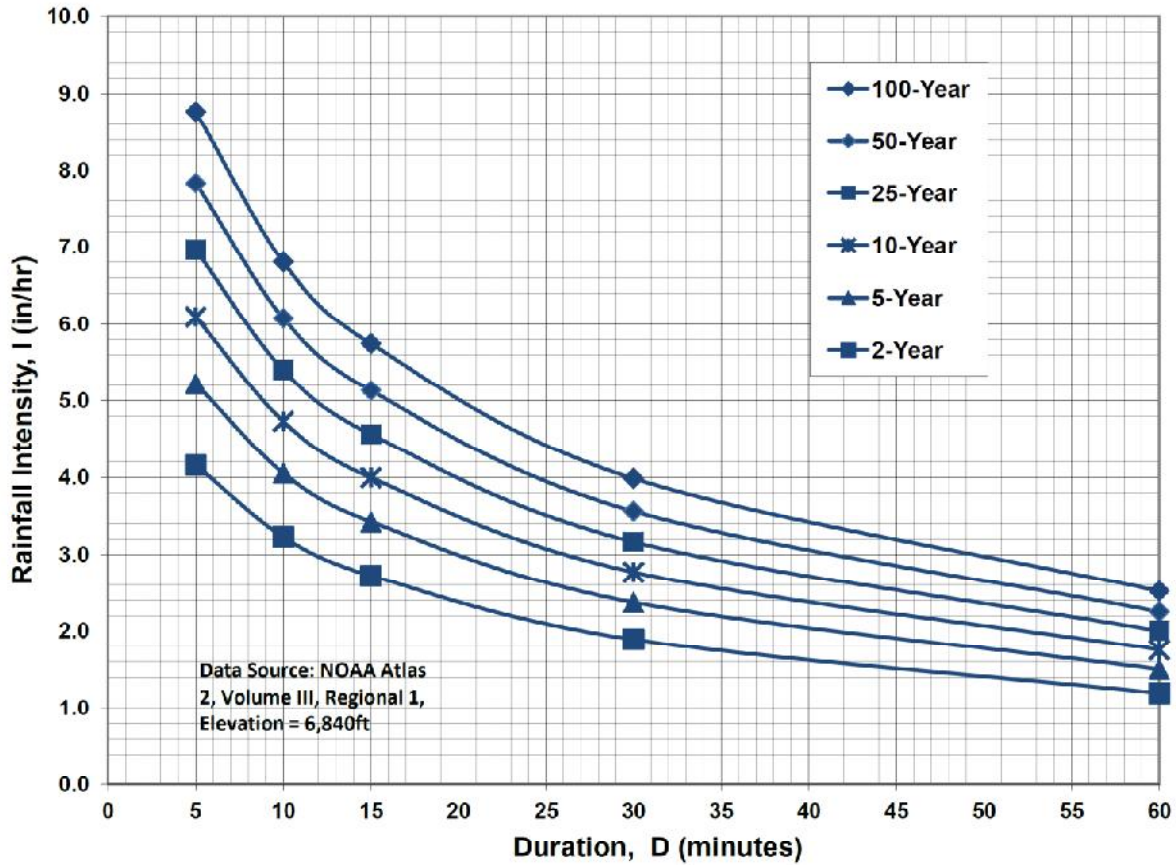

IDF Equations

$$I_{100} = -2.52 \ln(D) + 12.735$$

$$I_{50} = -2.25 \ln(D) + 11.375$$

$$I_{25} = -2.00 \ln(D) + 10.111$$

$$I_{10} = -1.75 \ln(D) + 8.847$$

$$I_5 = -1.50 \ln(D) + 7.583$$

$$I_2 = -1.19 \ln(D) + 6.035$$

Note: Values calculated by equations may not precisely duplicate values read from figure.

NORWOOD BIBLE CHURCH
COMPOSITE RUNOFF COEFFICIENTS

DEVELOPED CONDITIONS											
5-YEAR C VALUES											
BASIN	TOTAL AREA (AC)	(AC)	SUB-AREA 1 DEVELOPMENT/ COVER	C	AREA (AC)	SUB-AREA 2 DEVELOPMENT/ COVER	C	(AC)	SUB-AREA 3 DEVELOPMENT/ COVER	C	WEIGHTED C VALUE
D1.1a	1.46	0.150	BUILDING / ASPHALT	0.9	0.000	GRAVEL	0.59	1.310	LANDSCAPED	0.08	0.164
D1.1b	0.43	0.150	BUILDING / ASPHALT	0.9	0.000	GRAVEL	0.59	0.280	LANDSCAPED	0.08	0.366
D1.1a,D1.1b	1.89										0.210
D1.1c	1.91	0.892	BUILDING / ASPHALT	0.9	0.214	GRAVEL	0.59	0.804	LANDSCAPED	0.08	0.520
D1.1d	0.83	0.050	BUILDING / ASPHALT	0.9	0.000	GRAVEL	0.59	0.780	LANDSCAPED	0.08	0.129
D1.1a-D1.1d	4.63										0.324
CH2	0.77	0.200	BUILDING / ASPHALT	0.9	0.000	GRAVEL	0.59	0.570	LANDSCAPED	0.08	0.293
D1.1a-D1.1d,CH2	5.40										0.319
D1.1e	0.14	0.018	ASPHALT	0.9	0.000	GRAVEL	0.59	0.122	LANDSCAPED	0.08	0.185
100-YEAR C VALUES											
BASIN	TOTAL AREA (AC)	(AC)	SUB-AREA 1 DEVELOPMENT/ COVER	C	AREA (AC)	SUB-AREA 2 DEVELOPMENT/ COVER	C	(AC)	SUB-AREA 3 DEVELOPMENT/ COVER	C	WEIGHTED C VALUE
D1.1a	1.46	0.150	BUILDING / ASPHALT	0.96	0.000	GRAVEL	0.70	1.310	LANDSCAPED	0.35	0.413
D1.1b	0.43	0.150	BUILDING / ASPHALT	0.96	0.000	GRAVEL	0.70	0.280	LANDSCAPED	0.35	0.563
D1.1a,D1.1b	1.89										0.447
D1.1c	1.91	0.892	BUILDING / ASPHALT	0.96	0.214	GRAVEL	0.70	0.804	LANDSCAPED	0.35	0.674
D1.1d	0.83	0.050	BUILDING / ASPHALT	0.96	0.000	GRAVEL	0.70	0.780	LANDSCAPED	0.35	0.387
D1.1a-D1.1d	4.63										0.530
CH2	0.77	0.200	BUILDING / ASPHALT	0.96	0.000	GRAVEL	0.70	0.570	LANDSCAPED	0.35	0.508
D1.1a-D1.1d,CH2	5.40										0.527
D1.1e	0.14	0.018	ASPHALT	0.96	0.000	GRAVEL	0.7	0.122	LANDSCAPED	0.08	0.193
IMPERVIOUS AREAS											
BASIN	TOTAL AREA (AC)	(AC)	SUB-AREA 1 DEVELOPMENT/ COVER	PERCENT IMPERVIOUS	AREA (AC)	SUB-AREA 2 DEVELOPMENT/ COVER	PERCENT IMPERVIOUS	(AC)	SUB-AREA 3 DEVELOPMENT/ COVER	PERCENT IMPERVIOUS	WEIGHTED % IMP
D1.1a	1.46	0.150	BUILDING / ASPHALT	100	0.000	GRAVEL	80	1.310	LANDSCAPED	0	10.274
D1.1b	0.43	0.150	BUILDING / ASPHALT	100	0.000	GRAVEL	80	0.280	LANDSCAPED	0	34.884
D1.1a,D1.1b	1.89										15.873
D1.1c	1.91	0.892	BUILDING / ASPHALT	100	0.214	GRAVEL	80	0.804	LANDSCAPED	0	55.665
D1.1d	0.83	0.050	BUILDING / ASPHALT	100	0.000	GRAVEL	80	0.780	LANDSCAPED	0	6.024
D1.1a-D1.1d	4.63										30.523
CH2	0.77	0.200	BUILDING / ASPHALT	100	0.000	GRAVEL	80	0.570	LANDSCAPED	0	25.974
D1.1a-D1.1d,CH2	5.40										29.874

**NORWOOD BIBLE CHURCH
RATIONAL METHOD**

HISTORIC (PRE-DEVELOPMENT) CONDITIONS

BASIN	DESIGN POINT	AREA (AC)	C		Overland Flow			Channel flow					TOTAL Tc ⁽⁴⁾ (MIN)	TOTAL Tc ⁽⁴⁾ (MIN)	INTENSITY ⁽⁵⁾		PEAK FLOW	
			5-YEAR	100-YEAR	LENGTH (FT)	SLOPE (FT/FT)	Tco ⁽¹⁾ (MIN)	CHANNEL LENGTH (FT)	CONVEYANCE COEFFICIENT C	SLOPE (FT/FT)	SCS ⁽²⁾ VELOCITY (FT/S)	Tt ⁽³⁾ (MIN)			5-YR (IN/HR)	100-YR (IN/HR)	Q5 ⁽⁶⁾ (CFS)	Q100 ⁽⁶⁾ (CFS)
			D1.1	D1.1	5.0	0.080	0.350	300	0.023	24.5	320	15			0.028	2.51	2.1	26.6

DEVELOPED CONDITIONS

BASIN	DESIGN POINT	AREA (AC)	C		Overland Flow			Channel flow					TOTAL Tc ⁽⁴⁾ (MIN)	TOTAL Tc ⁽⁴⁾ (MIN)	INTENSITY ⁽⁵⁾		PEAK FLOW	
			5-YEAR	100-YEAR	LENGTH (FT)	SLOPE (FT/FT)	Tco ⁽¹⁾ (MIN)	CHANNEL LENGTH (FT)	CONVEYANCE COEFFICIENT C	SLOPE (FT/FT)	SCS ⁽²⁾ VELOCITY (FT/S)	Tt ⁽³⁾ (MIN)			5-YR (IN/HR)	100-YR (IN/HR)	Q5 ⁽⁶⁾ (CFS)	Q100 ⁽⁶⁾ (CFS)
			D1.1a	D1.1a	1.46	0.164	0.413	100	0.030	11.9	390	15			0.015	1.84	3.5	15.4
D1.1b		0.43	0.366	0.563	100	0.020	10.7	130	15	0.031	2.64	0.8	11.5	11.5	3.92	6.58	0.62	1.59
Tt D1.1a-D1.1b								170	15	0.035	2.81	1.0						
D1.1a,D1.1b	D1.1b	1.89	0.210	0.447									16.4	16.4	3.38	5.68	1.34	4.80
D1.1c	D1.1c	1.91	0.520	0.674	100	0.020	8.4	480	20	0.019	2.76	2.9	11.3	11.3	3.94	6.62	3.91	8.52
D1.1d		0.83	0.129	0.387	100	0.080	8.9	270	15	0.010	1.50	3.0	11.9	11.9	3.87	6.50	0.41	2.09
Tt D1.1b-D1.1d								285	15	0.010	1.50	3.2						
D1.1a-D1.1d	D1.1d	4.63	0.324	0.530									19.6	19.6	3.12	5.24	4.68	12.85
CH2	CH2	0.77	0.293	0.508	100	0.040	9.3	430	15	0.033	2.72	2.6	11.9	11.9	3.86	6.49	0.87	2.54
D1.1a-D1.1d,CH2	D1.1	5.40	0.319	0.527									19.6	19.6	3.12	5.24	5.37	14.90
D1.1e	D1.1e	0.14	0.185	0.193	70	0.043	8.6	320	15	0.016	1.90	2.8	11.4	11.4	3.93	6.59	0.10	0.18

1) OVERLAND FLOW Tco = (0.395*(1.1-RUNOFF COEFFICIENT)*(OVERLAND FLOW LENGTH^(0.5))/(SLOPE^(0.333))

2) SCS VELOCITY = C * ((SLOPE(FT/FT)^0.5)

C = 2.5 FOR HEAVY MEADOW

C = 5 FOR TILLAGE/FIELD

C = 7 FOR SHORT PASTURE AND LAWNS

C = 10 FOR NEARLY BARE GROUND

C = 15 FOR GRASSED WATERWAY

C = 20 FOR PAVED AREAS AND SHALLOW PAVED SWALES

3) MANNING'S CHANNEL TRAVEL TIME = L/V (WHEN CHANNEL VELOCITY IS KNOWN)

4) Tc = Tco + Tt

*** IF TOTAL TIME OF CONCENTRATION IS LESS THAN 5 MINUTES, THEN 5 MINUTES IS USED

5) INTENSITY BASED ON I-D-F EQUATIONS IN CITY OF COLORADO SPRINGS DRAINAGE CRITERIA MANUAL

$$I_5 = -1.5 * \ln(Tc) + 7.583$$

$$I_{100} = -2.52 * \ln(Tc) + 12.735$$

6) Q = CiA

APPENDIX C
HYDRAULIC CALCULATIONS

**NORWOOD BIBLE CHURCH
CHANNEL CALCULATIONS
DEVELOPED FLOWS**

PROPOSED CHANNELS

CHANNEL	PROPOSED SLOPE (%)	BOTTOM WIDTH (B, FT)	SIDE SLOPE (Z)	CHANNEL DEPTH (FT)	FRICTION FACTOR (n)	DESIGN POINT	BASIN Q100 (CFS)	CHANNEL PERCENT OF BASIN	Q100 FLOW (CFS) ^a	Q100 DEPTH (FT)	Q100 VELOCITY (FT/S)	CHANNEL LINING
D1.1a	1.0	0	4:1	1.5	0.030	D1.1a	3.5	100	3.5	0.6	2.2	GRASS
D1.1b	6.4	0	4:1	1.5	0.030	D1.1b	4.8	100	4.8	0.5	4.9	GRASS / TRM
D1.1c-Crossspan	1.4	0	50:1	1.0	0.016	D1.1c	8.5	50	4.3	0.2	2.3	CONCRETE
D1.1c-Chase	3.3	2	0:1	0.5	0.013	D1.1c	8.5	100	8.5	0.5	9.5	CONCRETE
D1.1c-Channel	6.7	4	4:1	1.5	0.030	D1.1c	8.5	100	8.5	0.3	5.1	GRASS / TRM
D1.1d	0.88	4	4:1	1.5	0.030	D1.1d	12.9	100	12.9	0.7	2.8	GRASS

^a Channel Q100 Flow = (Basin Q100) * (Channel Percent of Basin)

- 1) Channel flow calculations based on Manning's Equation
- 2) n = 0.03 for grass-lined non-irrigated channels
- 3) Vmax = 4.0 fps for 100-year flows w/ grass-lined channels (assuming grass-legume mixture)
(per EPC DCM Vol. 1, Table 10-4)
- 4) Vmax = 8.0 fps for 100-year flows w/ Erosion Control Blankets / Turf Reinforcement Mats (Tensar Eronet SC150 or equal)

The complete line of RollMax™ products offers a variety of options for both short-term and permanent erosion control needs. Reference the RollMax Products Chart below to find the right solution for your next project.



RollMax Product Selection Chart

	TEMPORARY						BIONET
	ERONET						
	DS75	DS150	S75	S150	SC150	C125	S75BN
Longevity	45 days	60 days	12 mo.	12 mo.	24 mo.	36 mo.	12 mo.
Applications	Low Flow Channels 4:1-3:1 Slopes	Moderate Flow Channels 3:1-2:1 Slopes	Low Flow Channels 4:1-3:1 Slopes	Moderate Flow Channels 3:1-2:1 Slopes	Medium Flow Channels 2:1-1:1 Slopes	High-Flow Channels 1:1 and Greater Slopes	Low Flow Channels 4:1-3:1 Slopes
Design Permissible Shear Stress lbs/ft ² (Pa)	Unvegetated 1.55 (74)	Unvegetated 1.75 (84)	Unvegetated 1.55 (74)	Unvegetated 1.75 (84)	Unvegetated 2.00 (96)	Unvegetated 2.25 (108)	Unvegetated 1.60 (76)
Design Permissible Velocity ft/s (m/s)	Unvegetated 5.00 (1.52)	Unvegetated 6.00 (1.52)	Unvegetated 5.00 (1.2)	Unvegetated 6.00 (1.83)	Unvegetated 8.00 (2.44)	Unvegetated 10.00 (3.05)	Unvegetated 5.00 (1.52)
Top Net	Lightweight accelerated photodegradable polypropylene 1.50 lbs/1000 ft ² (0.73 kg/100 m ²) approx wt	Lightweight accelerated photodegradable polypropylene 1.50 lbs/1000 ft ² (0.73 kg/100 m ²) approx wt	Lightweight photodegradable polypropylene 1.50 lbs/1000 ft ² (0.73 kg/100 m ²) approx wt	Lightweight photodegradable polypropylene 1.50 lbs/1000 ft ² (0.73 kg/100 m ²) approx wt	Heavyweight UV-stabilized polypropylene 2.9 lbs/1000 ft ² (1.47 kg/100 m ²) approx wt	Heavyweight UV-stabilized polypropylene 2.9 lbs/1000 ft ² (1.47 kg/100 m ²) approx wt	Leno woven, 100% biodegradable jute fiber 9.30 lbs/1000 ft ² (4.53 kg/100 m ²) approx wt
Center Net	N/A	N/A	N/A	N/A	N/A	N/A	N/A
Fiber Matrix	Straw fiber 0.50 lbs/yd ² (0.27 kg/m ²)	Straw fiber 0.50 lbs/yd ² (0.27 kg/m ²)	Straw fiber 0.50 lbs/yd ² (0.27 kg/m ²)	Straw fiber 0.50 lbs/yd ² (0.27 kg/m ²)	Straw/coconut matrix 70% Straw 0.35 lbs/yd ² (0.19 kg/m ²) 30% Coconut 0.15 lbs/yd ² (0.08 kg/m ²)	Coconut fiber 0.50 lbs/yd ² (0.27 kg/m ²)	Straw fiber 0.50 lbs/yd ² (0.27 kg/m ²)
Bottom Net	N/A	Lightweight accelerated photodegradable polypropylene 1.50 lbs/1000 ft ² (0.73 kg/100 m ²) approx wt	N/A	Lightweight photodegradable polypropylene 1.50 lbs/1000 ft ² (0.73 kg/100 m ²) approx wt	Lightweight photodegradable polypropylene 1.50 lbs/1000 ft ² (0.73 kg/100 m ²) approx wt	Heavyweight UV-stabilized polypropylene 2.9 lbs/1000 ft ² (1.47 kg/100 m ²) approx wt	N/A
Thread	Accelerated degradable	Accelerated degradable	Degradable	Degradable	Degradable	UV-stabilized polypropylene	Biodegradable

Hydraulic Analysis Report

Project Data

Project Title: Project - Norwood Bible Church
Designer: JPS
Project Date: Friday, September 22, 2023
Project Units: U.S. Customary Units
Notes:

Channel Analysis: Channel Analysis - Ditch D1.1a

Notes:

Input Parameters

Channel Type: Triangular
Side Slope 1 (Z1): 4.0000 ft/ft
Side Slope 2 (Z2): 4.0000 ft/ft
Longitudinal Slope: 0.0100 ft/ft
Manning's n: 0.0300
Flow: 3.5000 cfs

Result Parameters

Depth: 0.6255 ft
Area of Flow: 1.5649 ft²
Wetted Perimeter: 5.1579 ft
Hydraulic Radius: 0.3034 ft
Average Velocity: 2.2365 ft/s
Top Width: 5.0039 ft
Froude Number: 0.7048
Critical Depth: 0.5438 ft
Critical Velocity: 2.9589 ft/s
Critical Slope: 0.0211 ft/ft
Critical Top Width: 4.35 ft
Calculated Max Shear Stress: 0.3903 lb/ft²
Calculated Avg Shear Stress: 0.1893 lb/ft²

Channel Analysis: Channel Analysis - Ditch D1.1b

Notes:

Input Parameters

Channel Type: Triangular
Side Slope 1 (Z1): 4.0000 ft/ft
Side Slope 2 (Z2): 4.0000 ft/ft
Longitudinal Slope: 0.0640 ft/ft
Manning's n: 0.0300
Flow: 4.8000 cfs

Result Parameters

Depth: 0.4972 ft
Area of Flow: 0.9887 ft²
Wetted Perimeter: 4.0997 ft
Hydraulic Radius: 0.2412 ft
Average Velocity: 4.8550 ft/s
Top Width: 3.9773 ft
Froude Number: 1.7160 [TRM Lining Specified based on high velocities and Froude Number](#)
Critical Depth: 0.6170 ft
Critical Velocity: 3.1519 ft/s
Critical Slope: 0.0202 ft/ft
Critical Top Width: 4.94 ft
Calculated Max Shear Stress: 1.9855 lb/ft²
Calculated Avg Shear Stress: 0.9631 lb/ft²

Channel Analysis: Channel Analysis - Crossspan D1.1c

Notes:

Input Parameters

Channel Type: Triangular
Side Slope 1 (Z1): 50.0000 ft/ft
Side Slope 2 (Z2): 50.0000 ft/ft
Longitudinal Slope: 0.0140 ft/ft
Manning's n: 0.0160
Flow: 4.3000 cfs

Result Parameters

Depth: 0.1929 ft
Area of Flow: 1.8607 ft²
Wetted Perimeter: 19.2949 ft
Hydraulic Radius: 0.0964 ft
Average Velocity: 2.3109 ft/s
Top Width: 19.2910 ft
Froude Number: 1.3113
Critical Depth: 0.2150 ft
Critical Velocity: 1.8605 ft/s
Critical Slope: 0.0079 ft/ft
Critical Top Width: 21.50 ft
Calculated Max Shear Stress: 0.1685 lb/ft²
Calculated Avg Shear Stress: 0.0842 lb/ft²

Channel Analysis: Channel Analysis - Chase D1.1c

Notes:

Input Parameters

Channel Type: Rectangular
Channel Width: 2.0000 ft
Longitudinal Slope: 0.0330 ft/ft
Manning's n: 0.0130
Flow: 8.5000 cfs

Result Parameters

Depth: 0.4476 ft
Area of Flow: 0.8953 ft²
Wetted Perimeter: 2.8953 ft
Hydraulic Radius: 0.3092 ft
Average Velocity: 9.4944 ft/s
Top Width: 2.0000 ft
Froude Number: 2.5008
Critical Depth: 0.8247 ft
Critical Velocity: 5.1533 ft/s
Critical Slope: 0.0059 ft/ft
Critical Top Width: 2.00 ft
Calculated Max Shear Stress: 0.9218 lb/ft²
Calculated Avg Shear Stress: 0.6367 lb/ft²

Channel Analysis: Channel Analysis - Channel D1.1c

Notes:

Input Parameters

Channel Type: Trapezoidal
Side Slope 1 (Z1): 4.0000 ft/ft
Side Slope 2 (Z2): 4.0000 ft/ft
Channel Width: 4.0000 ft
Longitudinal Slope: 0.0670 ft/ft
Manning's n: 0.0300
Flow: 8.5000 cfs

Result Parameters

Depth: 0.3157 ft
Area of Flow: 1.6615 ft²
Wetted Perimeter: 6.6033 ft
Hydraulic Radius: 0.2516 ft
Average Velocity: 5.1160 ft/s
Top Width: 6.5256 ft
Froude Number: 1.7868
Critical Depth: 0.4447 ft
Critical Velocity: 3.3076 ft/s
Critical Slope: 0.0192 ft/ft
Critical Top Width: 7.56 ft
Calculated Max Shear Stress: 1.3199 lb/ft²
Calculated Avg Shear Stress: 1.0519 lb/ft²

TRM Lining Specified based on high velocities
and Froude Number

Channel Analysis: Channel Analysis - Channel D1.1d

Notes:

Input Parameters

Channel Type: Trapezoidal
Side Slope 1 (Z1): 4.0000 ft/ft
Side Slope 2 (Z2): 4.0000 ft/ft
Channel Width: 4.0000 ft
Longitudinal Slope: 0.0088 ft/ft
Manning's n: 0.0300
Flow: 12.9000 cfs

Result Parameters

Depth: 0.6792 ft
Area of Flow: 4.5622 ft²
Wetted Perimeter: 9.6010 ft
Hydraulic Radius: 0.4752 ft
Average Velocity: 2.8276 ft/s
Top Width: 9.4337 ft
Froude Number: 0.7165
Critical Depth: 0.5641 ft
Critical Velocity: 3.6556 ft/s
Critical Slope: 0.0180 ft/ft
Critical Top Width: 8.51 ft
Calculated Max Shear Stress: 0.3730 lb/ft²
Calculated Avg Shear Stress: 0.2609 lb/ft²

$Q_{100} \text{ (max)} = 8.5 \text{ cfs (DP-D1.1c); } D = 2.0 \text{ ft}$
 $Q / D^{1.5} = 8.5 / (2.0^{1.5}) = 3.0$

$$H_a = \frac{(H + Y_n)}{2}$$

Equation 9-19

Where the maximum value of H_a shall not exceed H , and:

D_a = parameter to use in place of D in Figure 9-38 when flow is supercritical (ft)

D_c = diameter of circular culvert (ft)

H_a = parameter to use in place of H in Figure 9-39 when flow is supercritical (ft)

H = height of rectangular culvert (ft)

Y_n = normal depth of supercritical flow in the culvert (ft)

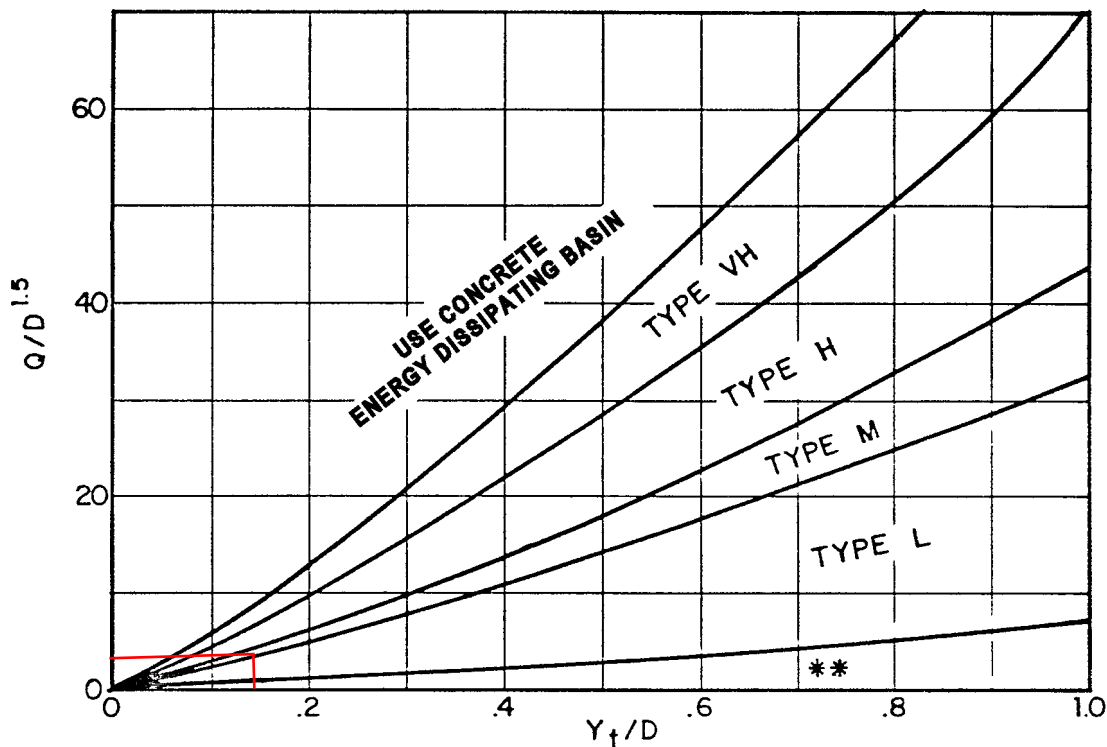

$Y_t = 0.3 \text{ ft (Channel D1.1c); } Y_t / D = (0.3 / 2.0) = 0.15$

Use D_a instead of D whenever flow is supercritical in the barrel.

** Use Type L for a distance of $3D$ downstream.

Use Type M Riprap

Figure 9-38. Riprap erosion protection at circular conduit outlet (valid for $Q/D^{2.5} \leq 6.0$)

APPENDIX D

DRAINAGE COST ESTIMATE

**NORWOOD BIBLE CHURCH - LOT 38, SADDLEHORN RANCH FILING NO. 3
ENGINEER'S COST ESTIMATE
DRAINAGE IMPROVEMENTS (PRIVATE)**

Item No.	Description	Quantity	Unit	Unit Cost (\$\$)	Total Cost (\$\$)
PRIVATE DRAINAGE FACILITIES (NON-REIMBURSABLE)					
	Riprap Aprons (12" Riprap)	16.0	TN	\$104	\$1,664
	18" RCP Driveway Culvert	59	LF	\$82	\$4,838
	18" RCP Flared End Sections	2	EA	\$492	\$984
	SUBTOTAL				\$7,486
	Contingency @ 10%				\$749
	TOTAL				\$8,235

The cost estimate submitted herein is based on time-honored practices within the construction industry. As such the engineer does not control the cost of labor, materials, equipment or a contractor's method of determining prices and competitive bidding practices or market conditions. The estimate represents our best judgement as design professionals using current information available at the time of the preparation. The engineer cannot guarantee that proposals, bids and/or construction costs will not vary from this cost estimate.

APPENDIX E

FIGURES

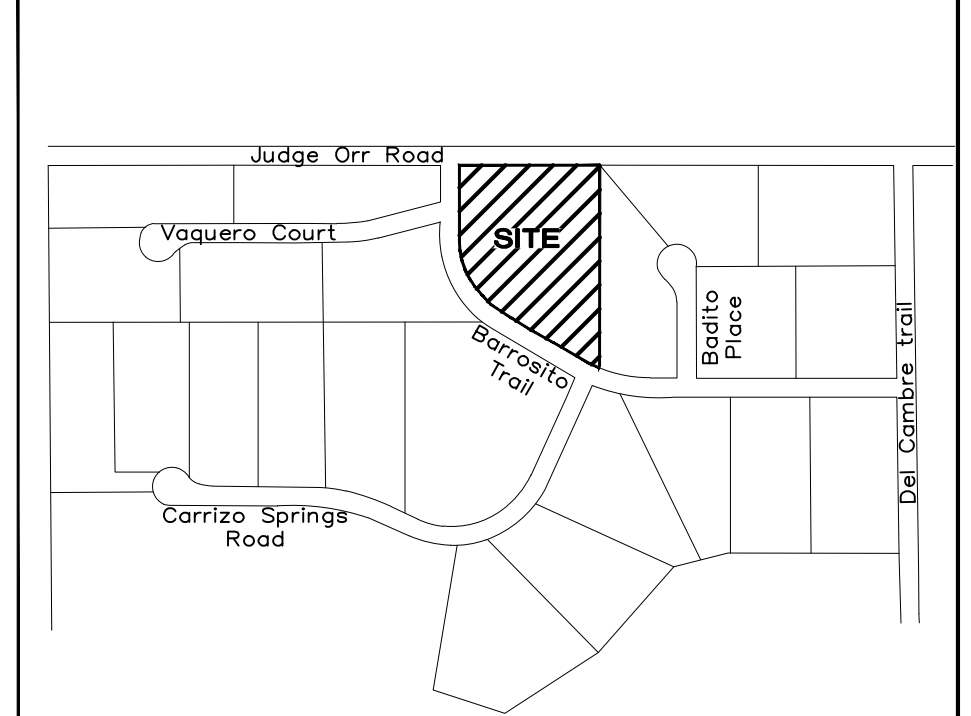
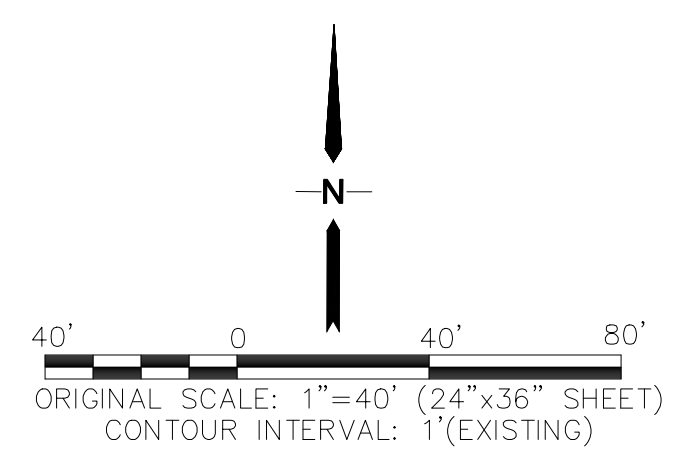
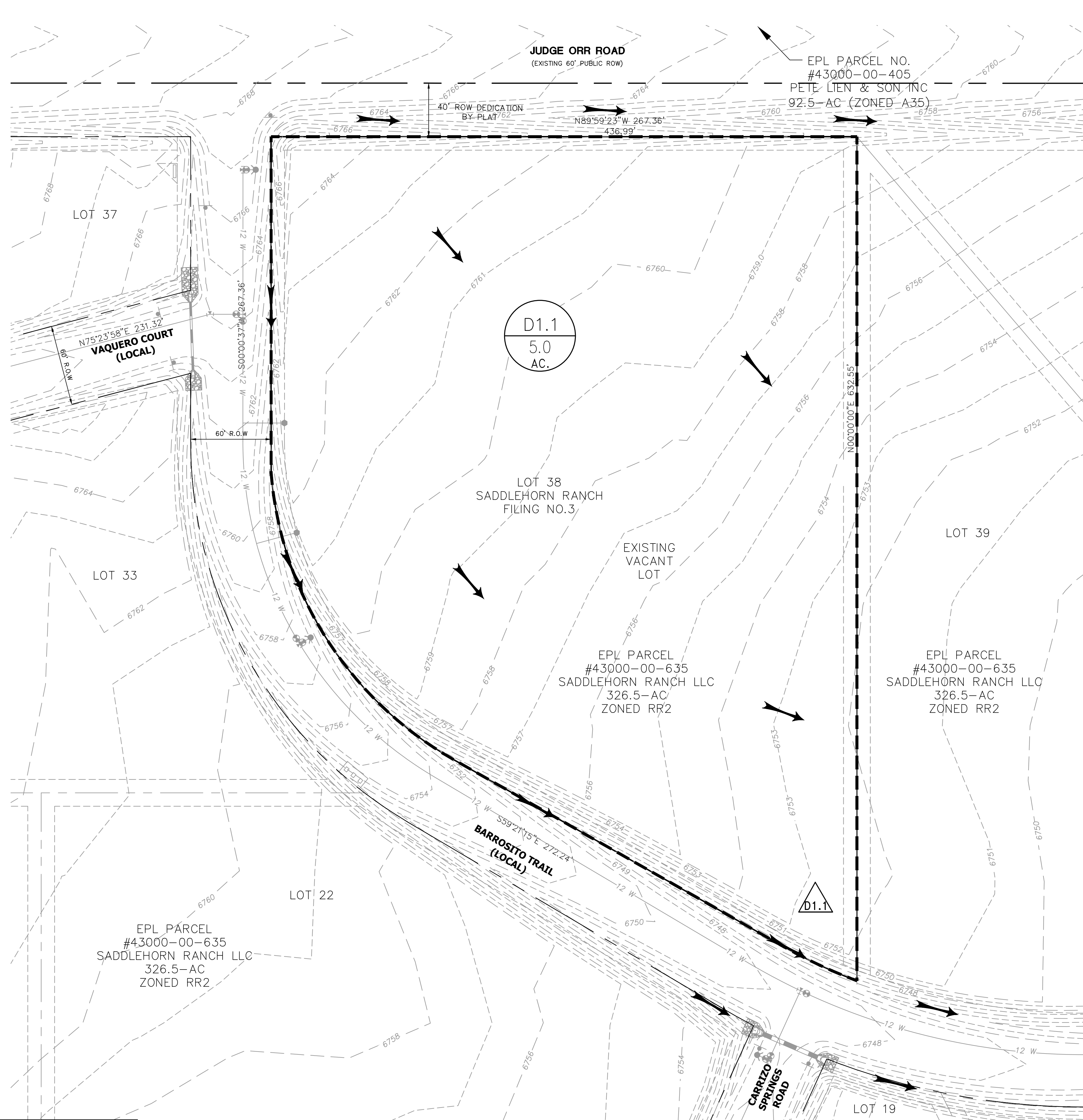

VICINITY MAP

LEGEND

- LIMITS OF DISTURBANCE
- FEMA 100-YEAR FLOODWAY
- FEMA 100-YR FLOODPLAIN
- PROPERTY BOUNDARY
- DRAINAGE BASIN BOUNDARY
- PROPOSED CONTOUR
- EXISTING CONTOUR
- FLOWLINE
- FLOW DIRECTION ARROW
- DESIGN POINT
- BASIN DESIGNATION
- BASIN AREA (ACRES)

SUMMARY HYDROLOGY TABLE

DESIGN POINT	Q5 (CFS)	Q100 (CFS)
D1.1	1.1	7.8

BASIN SUMMARY TABLE

BASIN	AREA (AC)	Q5 (CFS)	Q100 (CFS)
D1.1	5.0	1.1	7.8

BENCHMARK
 THE VERTICAL DATUM IS BASED OFF AN OPUS SOLUTION RAN ON CONTROL POINT #100 (NO. 4 REBAR) AND IS ADJUSTED TO NGVD 1929, ELEVATION 6754.61

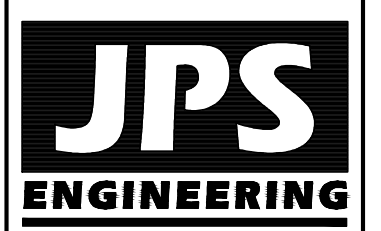

19 E. Willamette Ave.
 Colorado Springs, CO 80903
 PH: 719-477-9429
 FAX: 719-471-0766
 www.jpseng.com



CALL UTILITY NOTIFICATION CENTER OF COLORADO
 1-800-922-1987
 CALL 2-BUSINESS DAYS IN ADVANCE BEFORE YOU DIG, GRADE, OR EXCAVATE FOR THE MARKING OF UNDERGROUND MEMBER UTILITIES.

**NORWOOD BIBLE CHURCH
 LOT 38, SADDLEHORN RANCH FILING NO. 3**

**EXISTING CONDITIONS
 DRAINAGE PLAN**

NO.	REVISION	BY	DATE
1			

HORZ. SCALE: 1"=40'	DRAWN: PV
VERT. SCALE: N/A	DESIGNED: JPS
SURVEYED: JR	CHECKED: JPS
CREATED: 08/29/22	LAST MODIFIED: 06/25/24
PROJECT NO: 042303	MODIFIED BY: PV
SHEET:	

PCD FILE NO. PPR2346

EX1

PBMP SUMMARY TABLE

BASINS	PBMP TRIBUTARY AREA (AC)	PBMP
D1.1	5.0	SADDLEHORN RANCH DETENTION POND D

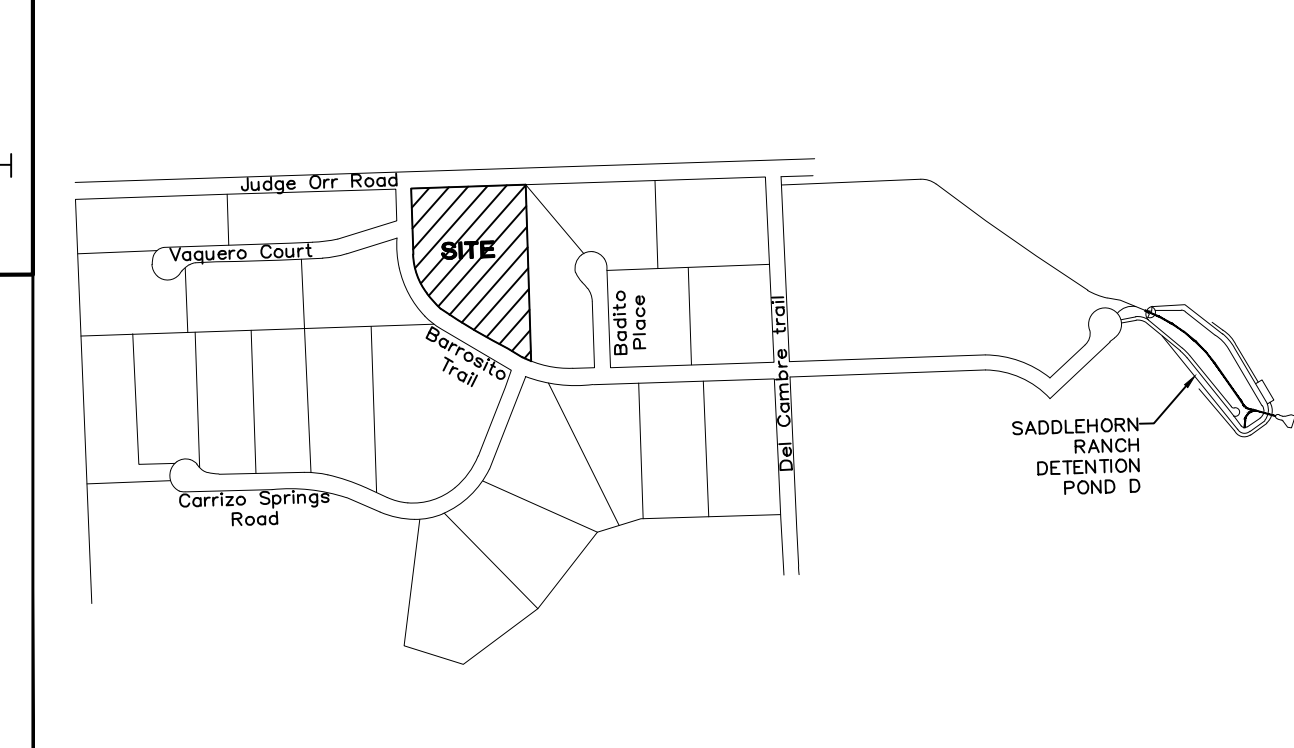

VICINITY MAP
SCALE 1"=700'

LEGEND

- L00 — LIMITS OF DISTURBANCE
- - - FEMA 100-YEAR FLOODWAY
- - - FEMA 100-YR FLOODPLAIN
- - - PROPERTY BOUNDARY
- - - DRAINAGE BASIN BOUNDARY
- - - 6750 PROPOSED CONTOUR
- - - 6750 EXISTING CONTOUR
- - - FLOWLINE
- ← FLOW DIRECTION ARROW
- (E) EXISTING
- (P) PROPOSED
- DS → DOWNSPOUT CONNECTION TO STORM SEWER; INSTALL TRANSITION COUPLINGS & EXTEND 6" PVC (SDR35) AT 1.0% MIN. SLOPE TO SD
- ▲ DESIGN POINT
- BASIN DESIGNATION
- BASIN AREA (ACRES)
- DISTURBED AREA RECEIVING WQC AT REGIONAL DETENTION POND (SADDLEHORN RANCH DETENTION POND D)

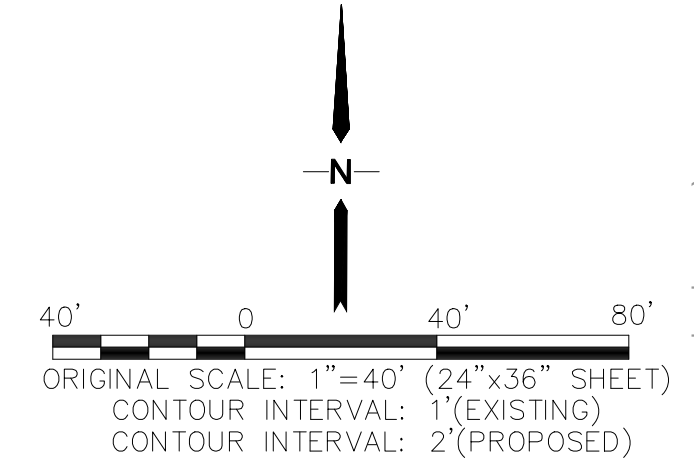
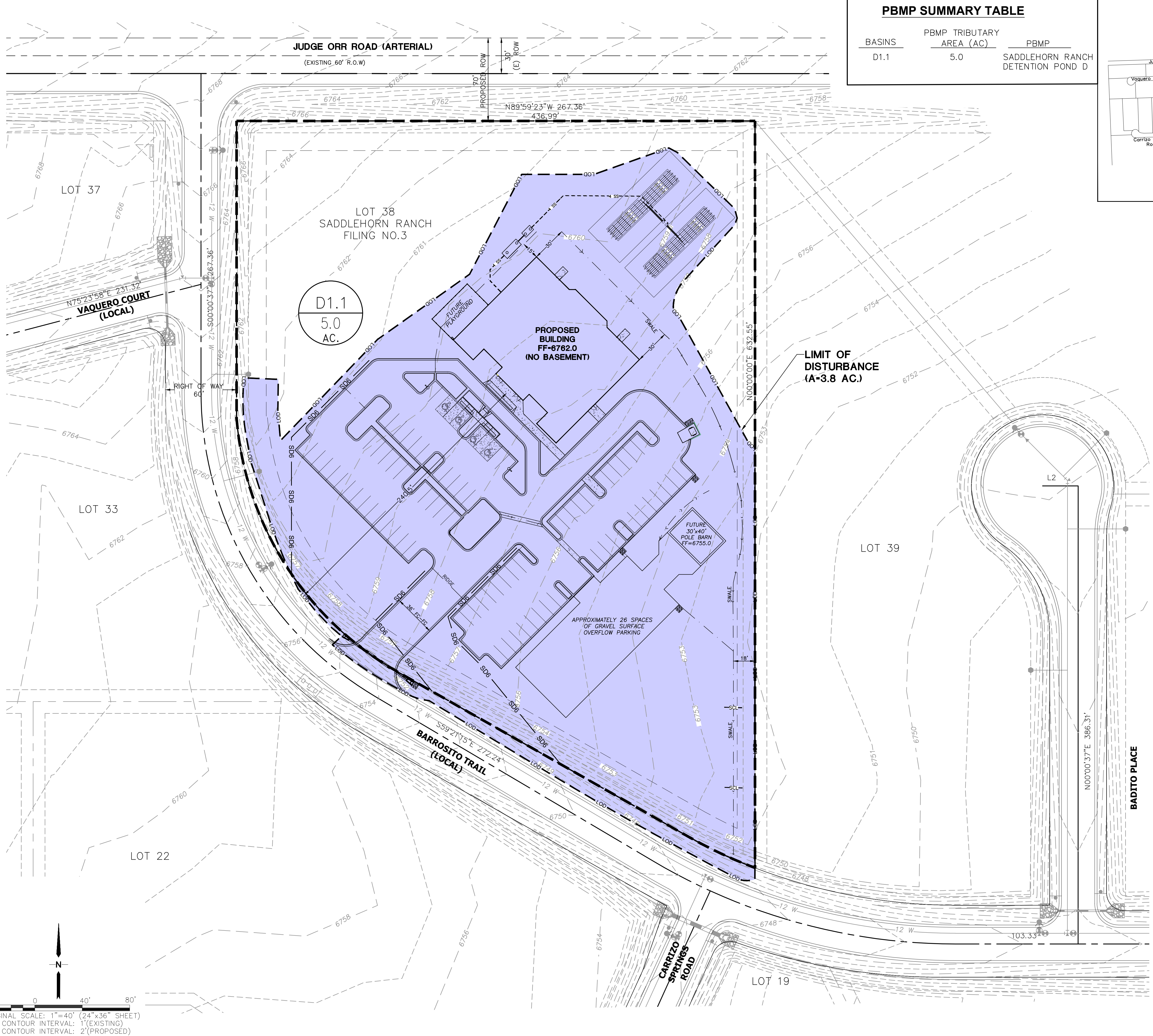

**NORWOOD BIBLE CHURCH
LOT 38, SADDLEHORN RANCH FILING NO. 3**

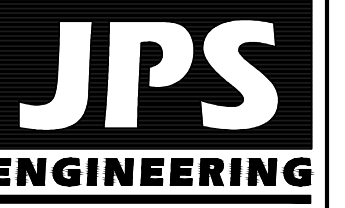

19 E. Willamette Ave.
Colorado Springs, CO
80903
PH: 719-477-9429
FAX: 719-471-0766
www.jpseng.com

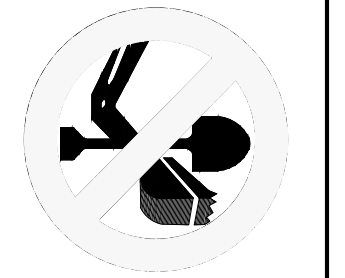

CALL UTILITY NOTIFICATION
CENTER OF COLORADO
1-800-922-1987
CALL 2-BUSINESS DAYS IN ADVANCE
BEFORE YOU DIG, GRADE, OR EXCAVATE
FOR THE MARKING OF UNDERGROUND
MEMBER UTILITIES.

No.	REVISION	BY	DATE
1		JPS	

**PBMP APPLICABILITY
EXHIBIT**

HORZ. SCALE: 1"=40'	DRAWN: PV
VERT. SCALE: N/A	DESIGNED: JPS
SURVEYED: JR	CHECKED: JPS
CREATED: 08/29/22	LAST MODIFIED: 06/26/24
PROJECT NO: 042303	MODIFIED BY: PV
SHEET: PBMP	

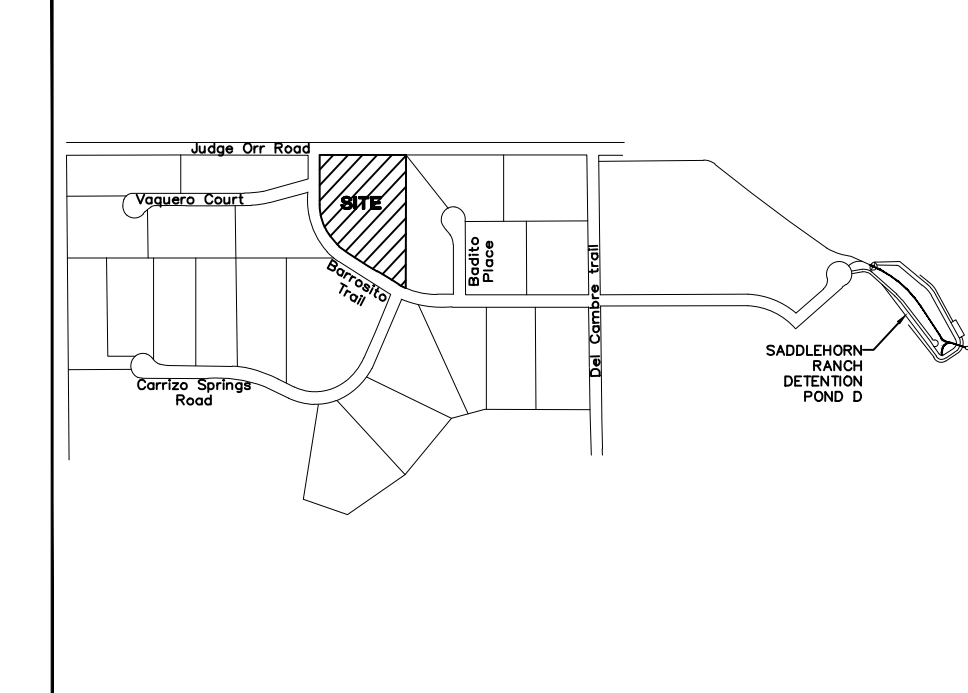
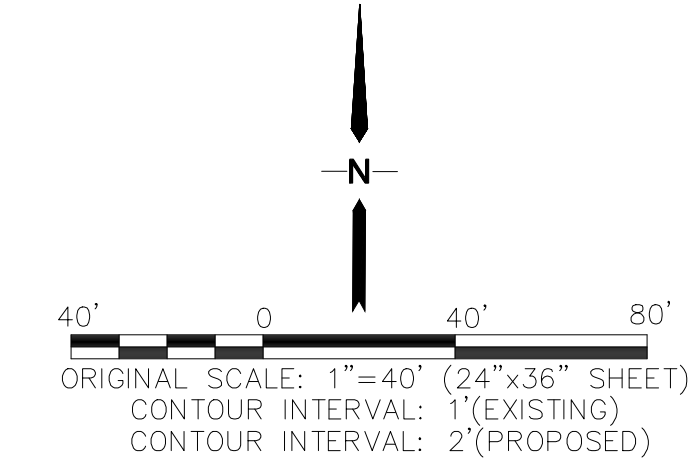
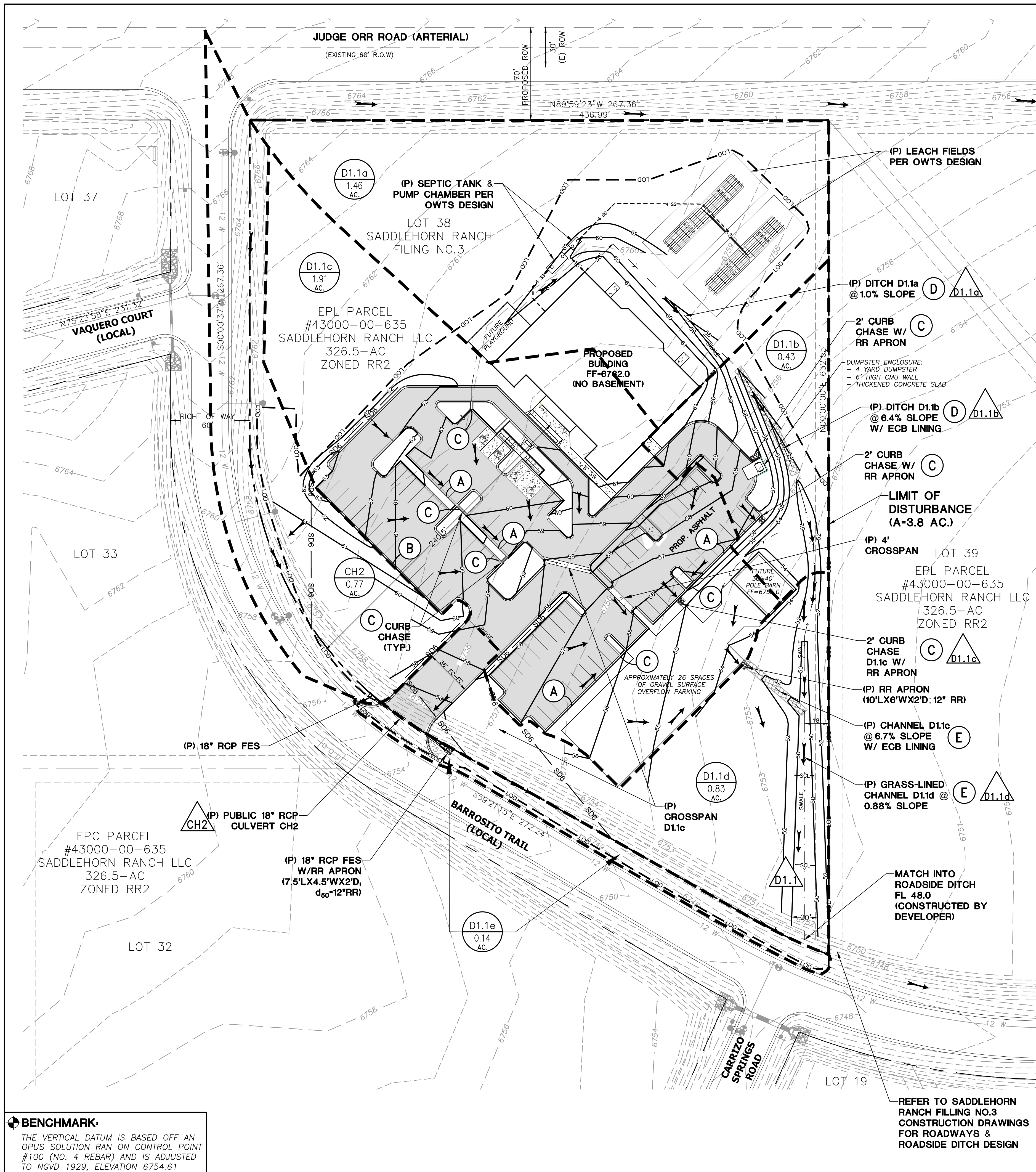

IMPERVIOUS AREA CALCULATIONS:

BASIN D1.1a AREA	= 1.46 AC.
SURFACE TYPE	AREA
PROP. BUILDINGS	6,313 SF
PROP. ASPHALT/SIDEWALK	120 SF
TOTAL IMPERVIOUS AREA	6,433 SF = 0.15 AC
= 10.3%	

IMPERVIOUS AREA CALCULATIONS:

BASIN D1.1b AREA	= 0.43 AC.
SURFACE TYPE	AREA
PROP+FUTURE BUILDINGS	539 SF
PROP. ASPHALT/SIDEWALK	2474 SF
TOTAL IMPERVIOUS AREA	2,953 SF = 0.07 AC
= 16.3%	

IMPERVIOUS AREA CALCULATIONS:

BASIN D1.1c AREA	= 1.91 AC.
SURFACE TYPE	AREA
PROP+FUTURE BUILDINGS	5,892 SF
PROP. ASPHALT/SIDEWALK	32,956 SF
PROP. GRAVEL 9,310 SF @ 80% IMPERVIOUS=	7,448 SF.
TOTAL IMPERVIOUS AREA	46,296 SF = 1.06 AC
= 55.5%	

IMPERVIOUS AREA CALCULATIONS:

BASIN D1.1d AREA	= 0.83 AC.
SURFACE TYPE	AREA
PROP. BUILDINGS	0,000 SF
PROP. ASPHALT/SIDEWALK	2,170 SF
TOTAL IMPERVIOUS AREA	2,170 SF = 0.05 AC
= 6.2%	

IMPERVIOUS AREA CALCULATIONS:

BASIN CH2 AREA	= 0.77 AC.
SURFACE TYPE	AREA
PROP. BUILDINGS	0,000 SF
PROP. ASPHALT/SIDEWALK	8,750 SF
TOTAL IMPERVIOUS AREA	8,750 SF = 0.2 AC
= 26.0%	

SUMMARY HYDROLOGY TABLE

DESIGN POINT	Q5 (CFS)	Q100 (CFS)
D1.1a	0.8	3.5
D1.1b	1.3	4.8
D1.1c	3.9	8.5
CH2	0.9	2.5
D1.1d	4.7	12.9
D1.1	5.4	14.9

BASIN SUMMARY TABLE

DESIGN POINT	Q5 (CFS)	Q100 (CFS)
D1.1a	0.8	3.5
D1.1b	1.3	4.8
D1.1c	3.9	8.5
D1.1d	4.7	12.9
D1.1e	0.1	0.18

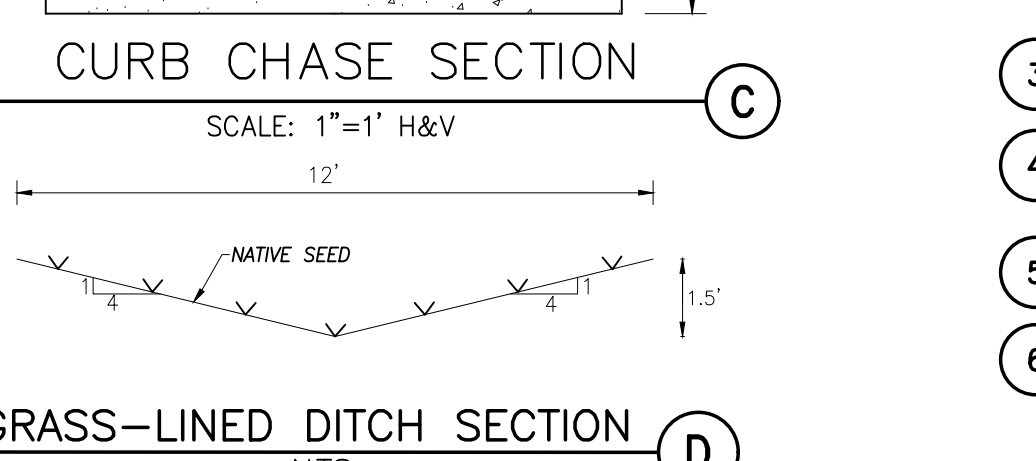
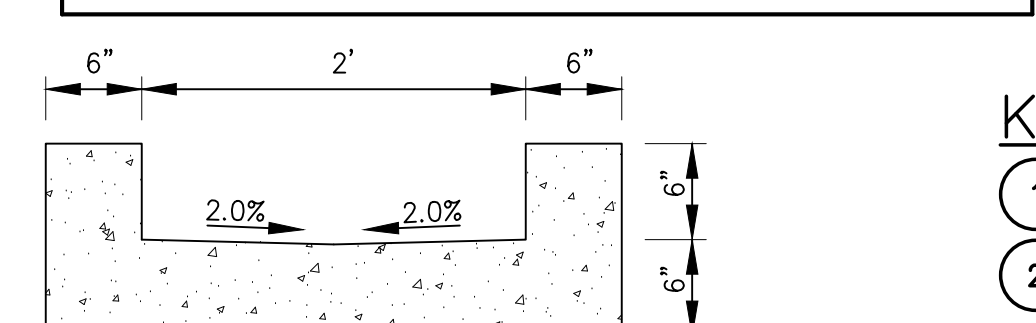
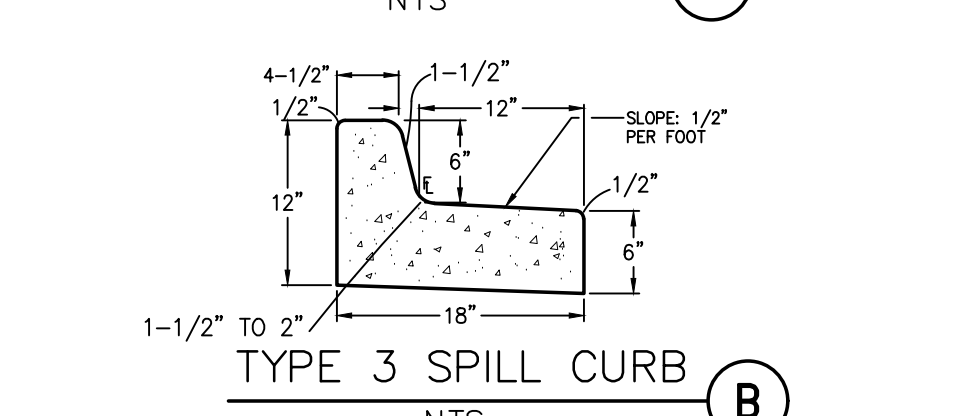
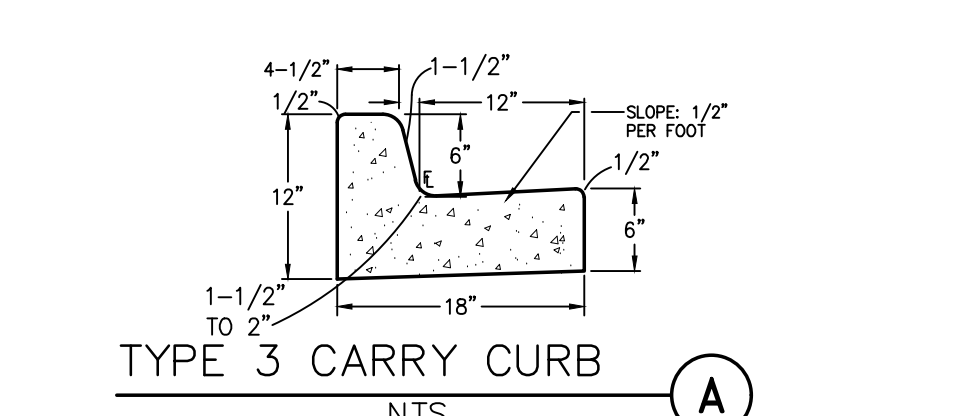
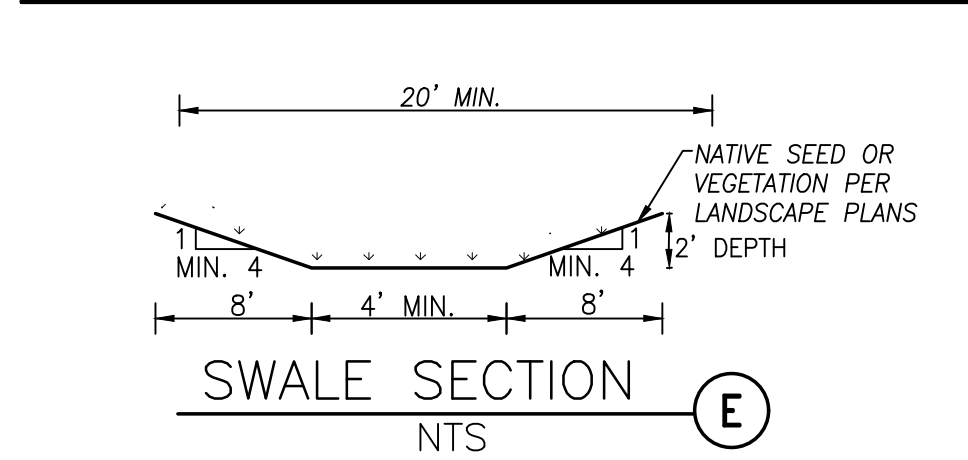
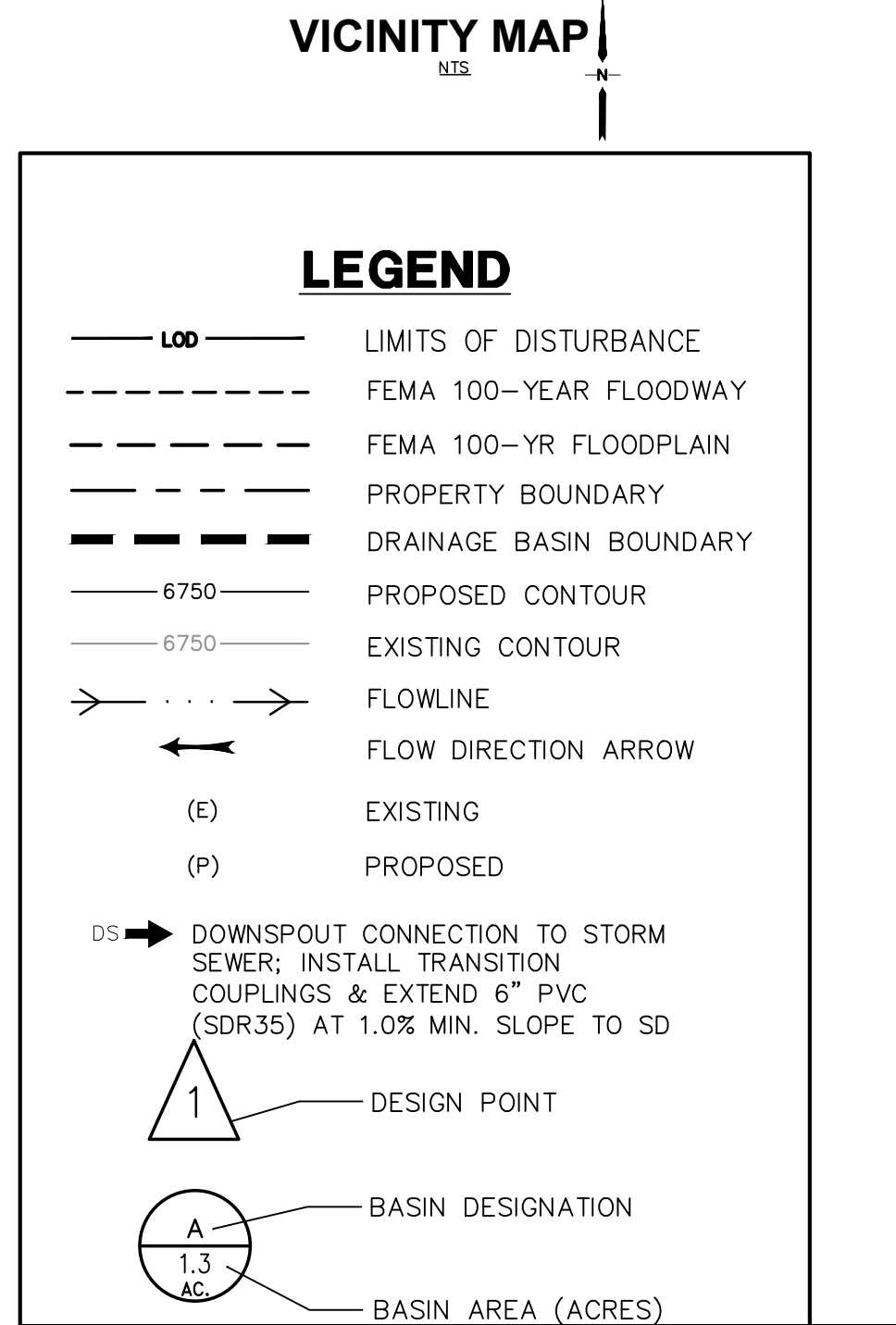

- KEYED NOTES:**
- TOPSOIL & STRIPPINGS STOCKPILE AREA
 - CONTRACTOR MAY WASTE EXCESS CUT MATERIAL OR BORROW SUITABLE FILL MATERIAL FROM THIS AREA. MAINTAIN POSITIVE DRAINAGE & MATCH INTO EXISTING GRADES WITH 3:1 MAX. SLOPE.
 - PREPARE AND COMPACT BUILDING FOUNDATION & SLABS PER PROJECT GEOTECHNICAL REPORT
 - PARKING LOT PAVING PER GEOTECHNICAL REPORT (4" ASPHALT OVER 6" AGGREGATE BASE UNLESS NOTED OTHERWISE)
 - STORAGE AREA FOR BUILDING MATERIALS, EQUIPMENT & CONSTRUCTION WASTE (CONTRACTOR MAY ADJUST AS NEEDED)
 - MIN 4'x4' CONCRETE LANDING AT DOOR W/2.0% MAX. SLOPE AWAY FROM BUILDING

BENCHMARK
THE VERTICAL DATUM IS BASED OFF AN OPUS SOLUTION RAN ON CONTROL POINT #100 (NO. 4 REBAR) AND IS ADJUSTED TO NGVD 1929, ELEVATION 6754.61

REFER TO SADDLEHORN RANCH FILING NO.3 CONSTRUCTION DRAWINGS FOR ROADWAYS & ROADSIDE DITCH DESIGN

NORWOOD BIBLE CHURCH LOT 38, SADDLEHORN RANCH FILING NO. 3

DEVELOPED DRAINAGE PLAN

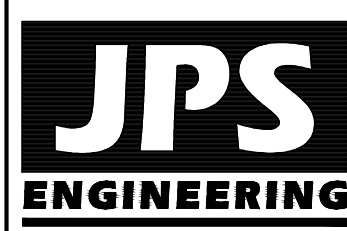

19 E. Wilamette Ave.
Colorado Springs, CO 80903
PH: 719-477-9429
FAX: 719-471-0766
www.jpsengr.com



CALL UTILITY NOTIFICATION CENTER OF COLORADO
1-800-922-1987
CALL 2-BUSINESS DAYS IN ADVANCE BEFORE YOU DIG, GRADE, OR EXCAVATE FOR THE MARKING OF UNDERGROUND MEMBER UTILITIES.

NO.	REVISION	BY	DATE

HORZ. SCALE: 1"=40'	DRAWN: PV
VERT. SCALE: N/A	DESIGNED: JPS
SURVEYED: N/A	CHECKED: JPS
CREATED: 08/29/22	LAST MODIFIED: 06/26/24
PROJECT NO: 042303	MODIFIED BY: PV
SHEET:	

PCD FILE NO. PPR2346

D1