

PARCEL SCHED #: 4300000635
 OWNER: GORILLA CAPITAL CO
 CONTACT: NATHAN STEELE
 PH: 949-609-9492
 EM: nathan.steele@roiropertygroup.com
 MAILING ADDRESS: 1342 HIGH ST
 EUGENE, OR 97401
 ZONING: RR-2.5
 LAND USE: AG GRAZING
 AREA: 14,222,775 SF (326.5 AC)
 DEVELOPED AREA: 217,800 SF (5.0 AC)

V3: Please include a graphical depiction of the screening mechanism

V3: Please indicate sight distance triangles and any plantings, signs, walls, structures, or other visual obstructions within the triangles where applicable

DUMPSTER ENCLOSURE:
 - 4 YARD DUMPSTER
 - 6' HIGH CMU WALL
 - THICKENED CONCRETE SLAB

LEGAL DESCRIPTION:
 N2 SEC 3-13-64 EX THAT PT CONVEYED BY REC NO 215008985, 215008986, 219146505, 219146506 & THAT PT PLATTED TO SADDLEHORN RANCH FIL NO 2

APPLICANT/PLAN PREPARER:
 VERTEX CONSULTING SERVICES
 CONTACT: NINA RUIZ
 719-733-8605
 nina.ruiz@vertexcos.com

LEGEND

---	PROPERTY LINE
---	BUILDING SETBACK
---	LANDSCAPE SETBACK
---	EX EASEMENT LINE
---	EX CONTOUR (MAJOR)
---	EX CONTOUR (MINOR)
---	EX WATER LINE
---	EX FIRE HYDRANT
---	EX RDWAY SIGN
4W	PP WATER/FIRE SERVICE LINE
WT	PP WATER SERVICE LINE
SD6	PP STORM DRAIN

GENERAL NOTES

1. THE PARTIES RESPONSIBLE FOR THIS PLAN HAVE FAMILIARIZED THEMSELVES WITH ALL CURRENT ACCESSIBILITY CRITERIA AND SPECIFICATION AND THE PROPOSED PLAN REFLECTS ALL SITE ELEMENTS REQUIRED BY THE APPLICABLE ADA DESIGN STANDARDS AND GUIDELINES AS PUBLISHED BY THE UNITED STATES DEPARTMENT OF JUSTICE. APPROVAL OF THIS PLAN BY EL PASO COUNTY DOES NOT ASSURE COMPLIANCE WITH THE ADA OR ANY OTHER FEDERAL OR STATE ACCESSIBILITY LAWS OR ANY REGULATIONS OR GUIDELINES ENACTED OR PROMULGATED UNDER OR WITH RESPECT TO SUCH LAWS.
2. FEMA 100-YR FLOODPLAIN NOT WITHIN SITE BOUNDARIES.
3. UTILITY LOCATIONS SHOWN ARE APPROXIMATE AND MAY NOT BE ALL INCLUSIVE. CONTRACTOR TO VERIFY. SEE GEC DRAWINGS FOR GRADING AND EROSION CONTROL DETAILS INCLUDING UTILITY DETAILS.

FOR REVIEW

NO.	REVISION/ISSUE	DATE

ROI PROPERTY GROUP
 NOR'WOOD BIBLE CHURCH
 ALTERNATE LANDSCAPE PLAN

VERTEX
 Consulting Services
 455 E. Pikes Peak Avenue, Suite 101
 Colorado Springs, Colorado 80903
 719-733-8605

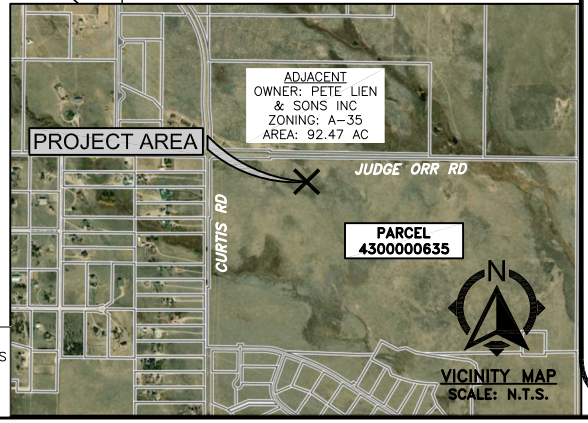

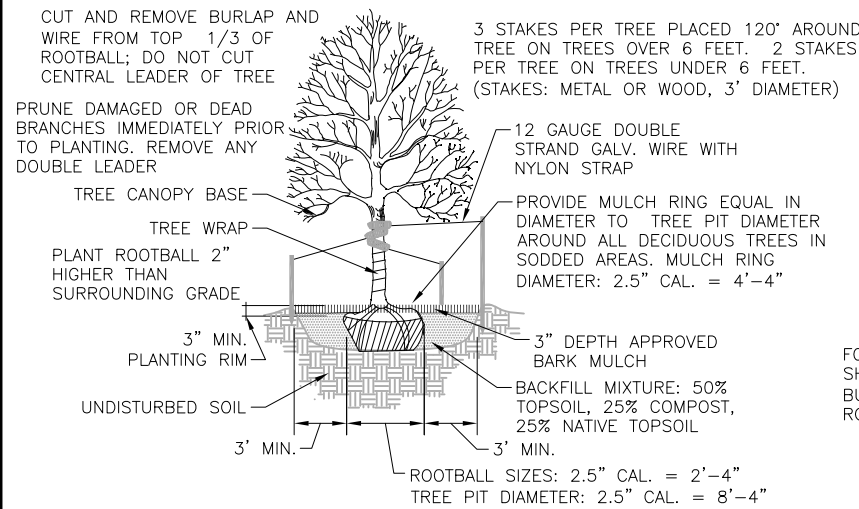

A TREE PLANTING
LS2 SCALE: N.T.S.

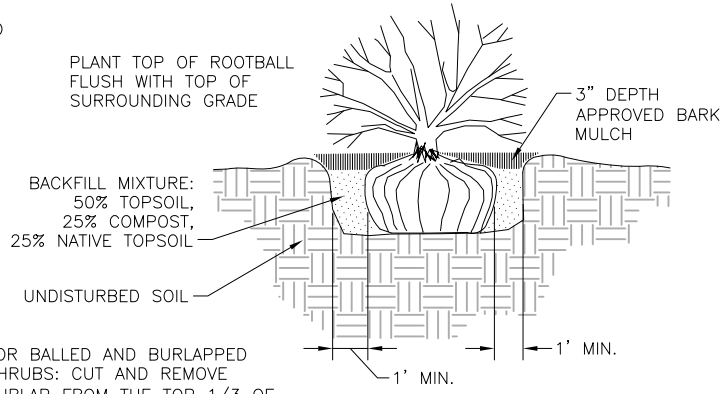

B SHRUB/DECORATIVE GRASS PLANTING
LS2 SCALE: N.T.S.

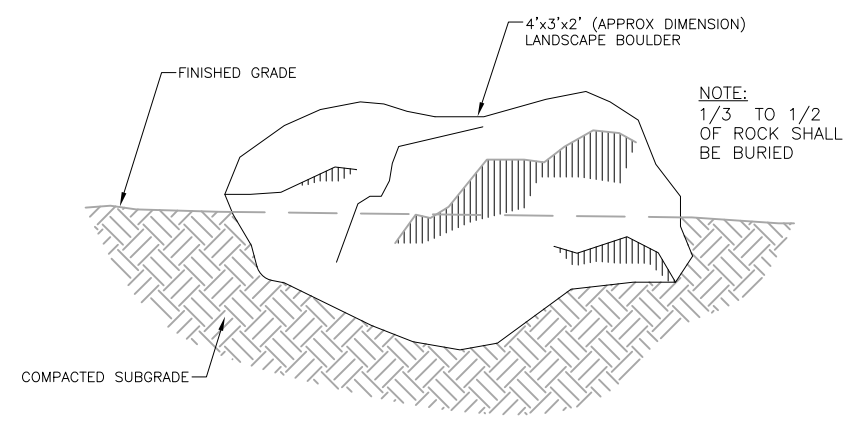

C LANDSCAPE BOULDER
LS2 SCALE: N.T.S.

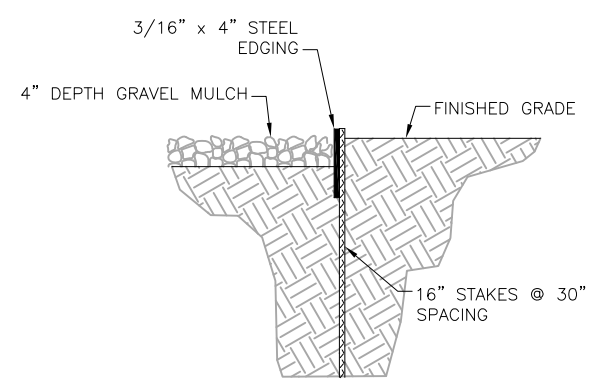

D STEEL EDGE
LS2 SCALE: N.T.S.

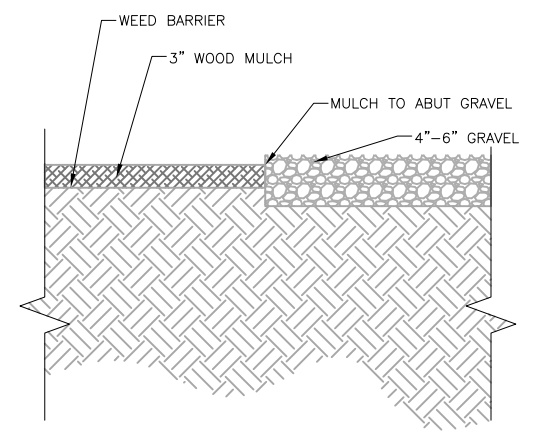

E GRAVEL @ MULCH
LS2 SCALE: N.T.S.

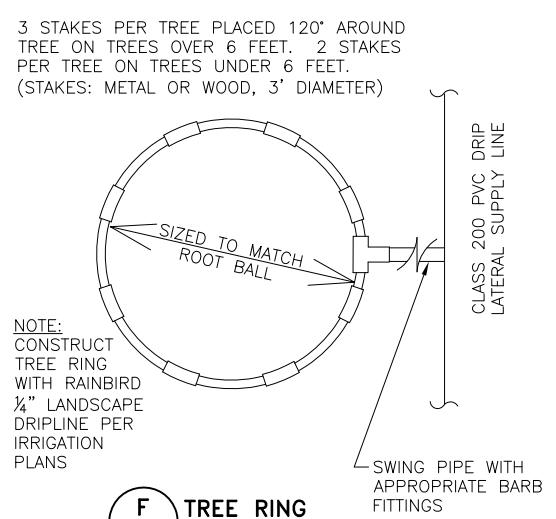

F TREE RING
LS2 SCALE: N.T.S.

LANDSCAPE SCHEDULE - HARDSCAPE/MULCH

3/8" PEA GRAVEL: WASHED RIVER ROCK OR APPROVED EQUAL
BREEZE/MINUS: PIONEER GRANITE OR APPROVED EQUAL
DECORATIVE ROCK: 3/4" - 1-1/2" MIX PIONEER GRANITE OR APPROVED EQUAL
SHREDDED WOOD MULCH: BROWN
DECORATIVE ROCK BOULDERS: PIONEER GRAY GRANITE OR APPROVED EQUAL

- 1 TYP PLANTING. REF: DETAILS LEFT
- 2 STEEL EDGE. TYP FOR SEPARATION BETWEEN SEED AND MULCH AREAS (GRAVEL, BREEZE, ROCK, WOOD MULCH). REF: DETAIL D/LS2
- 3 3/8" PEA GRAVEL @ 4" DEPTH MIN
- 4 BREEZE/MINUS @ 4" DEPTH MIN
- 5 DECORATIVE ROCK @ 4" DEPTH MIN
- 6 SHREDDED WOOD MULCH @ 3" DEPTH MIN
- 7 DECORATIVE ROCK BOULDERS. REF: DETAIL C/LS2

LANDSCAPE COVERAGE:

REDUCED BOUNDARY AREA (97,830)	REQUIRED	PROVIDED	REMARKS
ROADWAY FRONTAGE			
-DEPTH	15'	15'	
-TREES	8	8	
PARKING LOT	5	7	
INTERNAL	4,892 SF	6,425 SF	INCLUDES RDWAY FRONTAGE, EXCLUDES PARKING LOT LANDSCAPE

LANDSCAPE SCHEDULE - XERIC/LOW WATER VEGETATION

SYMBOL	BOTANICAL NAME	COMMON NAME	QTY.	MATURE SIZE (HxW)	PLANTING SIZE (MIN)	COMMENTS
	GRASS					
	SCHIZACHYRIUM SCOPARIUM	LITTLE BLUESTEM	84	2'-0" x 1'-6"	#3 CONT.	MAINTAIN SHAPE AND SIZE BY PRUNING LATE MARCH
	CALAMAGROSTIS ACUTIFLORA	KARL FOERSTER FEATHER REED	68	4'/6"-0" x 2'-0"	#5 CONT.	CUT CLUMPS OF GRASS NEAR THE GROUND LATE WINTER PRIOR TO NEW SHOOTS APPEARING
	SHRUB					
	RHUS TRILOBATA	SKUNKBUSH SUMAC	11	4'-0" x 3'-8"	#5 CONT.	MAINTAIN SHAPE AND SIZE BY PRUNING LATE WINTER
	POTENTILLA FRUTICOSA	GOLDSTAR POTENTILLA	58	2'-6" x 3'-0"	#5 CONT.	MAINTAIN SHAPE AND SIZE BY PRUNING EARLY SPRING
	GROUNDCOVER					
	RHUS TRILOBATA (R.AROMATICA 'GRO-LOW')	GROW-LOW FRAGRANT SUMAC	20	4'-0" x 3'-0"	#5 CONT.	MAINTAIN SHAPE AND SIZE BY PRUNING EARLY SPRING
	EVERGREEN TREE					
	PINUS EDULIS	PINON PINE	3	25'-0" x 15'-0"	4' MIN. HEIGHT	MUST ARRIVE BALLED AND BURLAPPED. PRUNE TO SHAPE TREE AT EARLY GROWTH
	JUNIPERUS SCOPULORUM	ROCKY MOUNTAIN JUNIPER	13	15'-0" x 8'-0"	4' MIN. HEIGHT	MUST ARRIVE BALLED AND BURLAPPED. PRUNE OUT SPORE HORNS WHEN SEEN IN SPRING
	DECIDUOUS ORNAMENTAL TREE					
	ROBINIA NEOMEXICANA	NEW MEXICO LOCUST	5	15'/25'-0" x 10'/15'-0"	1" CAL	MUST ARRIVE BALLED AND BURLAPPED. CALIPER SHALL BE MEASURED 6" ABOVE GROUND
	GLEDITSIA TRIACANTHOS VAR. INERMIS	IMPERIAL HONEYLOCUST	2	35'-0" x 30'-0"	1.5" CAL	MUST ARRIVE BALLED AND BURLAPPED. PRUNING BEST DONE IN LATE WINTER TO EARLY SPRING

LANDSCAPE NOTES:

1. **PLANT QUANTITY AND SUBSTITUTION:** IN CASE OF DISCREPANCY IN PLANT QUANTITIES SHOWN ON THE PLANT TABLE AND THOSE SHOWN ON THE PLANTING PLAN, THE QUANTITIES SHOWN ON THE PLANTING PLAN SHALL GOVERN. THE MINIMUM ACCEPTABLE SIZES OF PLANTS MEASURED BEFORE PRUNING WITH BRANCHES IN NORMAL POSITION SHALL CONFORM TO THE PLANTING SIZES AS SPECIFIED IN THE SCHEDULE. ANY SUBSTITUTION OF PLANT SIZE OR SPECIES MUST BE SUBMITTED TO THE OWNER/OWNER REPRESENTATIVE IN WRITING FOR APPROVAL PRIOR TO INSTALLATION.
 2. **ACCEPTABLE PLANT MATERIAL:** ALL PLANTS SHALL MEET OR EXCEED STANDARDS SET BY THE "COLORADO NURSERY ASSOCIATION," AND THE "AMERICAN STANDARD OF NURSERY STOCK." ALL PLANTS SHALL BE TYPICAL OF THEIR SPECIES, HEALTHY, FREE OF DISEASE, INSECT PESTS, MECHANICAL INJURIES, AND HAVE ADEQUATE ROOT SYSTEMS. ALL PLANTINGS SHALL BE INSTALLED PER PLANTING DETAILS. ALL PLANT MATERIAL SHALL BE INSPECTED BY THE OWNER/OWNER REPRESENTATIVE PRIOR TO INSTALLATION. STAKING/CONTRACTOR INSPECTION NOTE: ALL PLANTING LOCATIONS TO BE STAKED AND INSPECTED BY CONTRACTOR PRIOR TO INSTALLATION. ALL PLANTS TO BE INSPECTED AT NURSERY LOCATION PRIOR TO TRANSPORTING TO THE SITE.
 3. **SITE DISTURBANCE:** ALL AREAS OF SITE DISTURBANCE DUE TO CONSTRUCTION SHALL BE RENOVATED OR PLANTED PER THIS PLAN UNLESS OTHERWISE NOTED. SITE-SPECIFIC LANDSCAPING SHALL AT A MINIMUM, INCLUDE REVEGETATION OF DISTURBED AREAS WITH MATERIALS INDIGENOUS TO THE SITE OR OTHERWISE ADAPTABLE.
 4. **SOIL AMENDMENTS:** CONTRACTOR SHALL AMEND PLANTING AREAS AS FOLLOWS:
-ADD MINIMUM OF 3 CUBIC YARDS OF WELL-COMPOSTED AGED MANURE OR PREMIUM COMPOST PER 1000 S.F.
-ALL AMENDED AREAS SHALL BE TILLED TO A DEPTH OF 6" PRIOR TO PLANTING.
-3 CUBIC YARDS PER 1000 S.F. OF WELL-COMPOSTED AGED MANURE OR PREMIUM COMPOST.
-ALL AMENDED AREAS SHALL BE TILLED TO A DEPTH OF 6" PRIOR TO PLANTING.
 5. **SEEDED TURF:** ALL SEEDED OR HYDROMULCHED AREAS SHALL DEMONSTRATE 95% GERMINATION PRIOR TO FINAL ACCEPTANCE.
 6. **IRRIGATION:** OWNER TO IRRIGATE FOR ONE TO TWO GROWING SEASONS UNTIL ESTABLISHED AND ON AN AS-NEEDED BASIS THEREAFTER. DISTURBED AREA SEED/GRASS MIXTURE MUST BE IRRIGATED BY OWNER UNTIL ESTABLISHED AND IN TIMES OF DROUGHT. THE ON-GOING MAINTENANCE OF THE NATIVE GRASS IS THE RESPONSIBILITY OF OWNER.
 7. **INORGANIC MULCH AND FABRIC:** ALL PLANTINGS TO RECEIVE 3-INCH DEPTH OF INORGANIC MULCH. MULCH RINGS TO BE 15-INCH DIA. FOR (5) GALLON SHRUBS/GRASSES (SEE DRAWING DETAILS). HIGH QUALITY COMMERCIAL-GRADE (SPUN-BONDED POLYPROPYLENE OR EQUAL) LANDSCAPING FABRIC SHALL BE APPLIED UNDER ALL ROCK/MULCH BASES.
 8. **STEEL EDGE:** ALL EDGER SHALL BE ACME 4" PERFORATED STEEL EDGER "SELF COLORING" 14 GAUGE OR APPROVED EQUAL.
 9. **APPROVAL:** ANY FIELD CHANGES OR DEVIATIONS TO THESE PLANS WITHOUT PRIOR APPROVAL OF AN AMENDED DEVELOPMENT PLAN MAY RESULT IN A DELAY OF FINAL APPROVAL AND THE ISSUANCE OF A CERTIFICATE OF OCCUPANCY.
 10. **FINAL TREE AND SHRUB LOCATIONS:** ALL TREE LOCATIONS SHALL BE STAKED FOR APPROVAL BY OWNER/OWNER REPRESENTATIVE PRIOR TO PLANTING. SHRUBS SHALL BE PLACED IN THEIR LOCATIONS PER THIS PLAN AND APPROVED BY OWNER/OWNER REPRESENTATIVE. THE FINAL LOCATION OF TREES TO BE PLANTED MAY REQUIRE ADJUSTMENT BASED ON APPROVAL OF THE FINAL UTILITIES PLANS AND ANY ASSOCIATED FINAL EASEMENTS LOCATIONS.
 11. **COMPLIANCE WITH PLANS:** THE COMPLETED LANDSCAPING SHALL COMPLY WITH THE APPROVED ALTERNATE LANDSCAPE PLAN AND SHALL INCLUDE THE QUANTITIES, LOCATIONS, SPECIES AND SIZES OF PLANTS AND OTHER LANDSCAPE MATERIALS AS REPRESENTED ON THE APPROVED PLAN. SEEDED LANDSCAPE AREAS SHALL HAVE NO BARE AREAS LARGER THAN 6 SQUARE INCHES AFTER GERMINATION.
 12. **MAINTENANCE:**
A. THE OWNER IS RESPONSIBLE FOR ALL REGULAR AND NORMAL MAINTENANCE OF REQUIRED LANDSCAPING INCLUDING WEEDING, IRRIGATION, FERTILIZING, PRUNING AND MOWING.
B. REPLACEMENT OF DEAD, DISEASED OR SUBSTANTIALLY DAMAGED PLANT MATERIALS SHALL OCCUR WITHIN 6 MONTHS FROM WHEN THE PLANT MATERIAL DIED, OR WHEN THE INSPECTION DETERMINED THE PLANT MATERIAL WAS DEAD OR DAMAGED. REPLACEMENT SHALL BE OF THE SAME OR SIMILAR TYPE AS ORIGINALLY APPROVED. AN ALTERNATIVE TYPE OF SPECIES SHALL REQUIRE APPROVAL BY THE PCD DIRECTOR.
C. MAINTENANCE INSPECTIONS MAY BE PERFORMED PERIODICALLY. FAILURE TO MAINTAIN THE LANDSCAPING IN COMPLIANCE WITH THE APPROVAL IS CONSIDERED A ZONING VIOLATION.
- * THE PROPOSED ALTERNATE LANDSCAPE DESIGN INTENT PROMOTES WATER CONSERVATION WHILE MEETING THE PURPOSES DESCRIBED IN THE EL PASO COUNTY LAND DEVELOPMENT CODE.

GENERAL NOTES

FOR REVIEW

NO.	REVISION/ISSUE	DATE

ROI PROPERTY GROUP
NORWOOD BIBLE CHURCH
ALTERNATE LANDSCAPE PLAN
DETAILS

VERTEX
Consulting Services
455 E. Pikes Peak Avenue, Suite 101
Colorado Springs, Colorado 80903
719-733-8605

PROJECT NO.	SHEET
DATE 10/19/23	LS2
PREPARED GGM	
APPROVED CAD	