

**Construction Activities**  
**Stormwater Management Plan (SWMP)**

**Lot1 Seder Subdivision**  
**(Landscape Endeavors Building Addition)**

2725 Akers Drive, Colorado Springs, Colorado 80922

**Permittee:**

CES Property Endeavors, LLC  
9818 Morning Vista Drive, Peyton, Colorado 80831  
(719) 683-5480

**GEC Administrator:**

Name: \_\_\_\_\_ Cell Phone: \_\_\_\_\_

Address: \_\_\_\_\_

Office Phone Number: \_\_\_\_\_

SWMP Checklist Item 1. Add Contractor information to cover/title sheet. If unknown, add a placeholder to be updated prior to the pre-construction meeting.

**Prepared for:**

CES Property Endeavors, LLC  
9818 Morning Vista Drive  
Peyton, Colorado 80831  
(719) 683-5480

**Prepared by:**



1604 South 21st Street  
Colorado Springs, Colorado 80904  
(719) 630-7342

Kiowa Project No. 24060

**January 31, 2025**

**EPC FILE NO. PPR255**

**Signature Page 1**

**Lot1 Seder Subdivision**

**Contractor's Statement**

I will comply with the requirements of the SWMP including Construction Control Measure inspection requirements and final stabilization requirements. I acknowledge the responsibility to determine whether the construction activities on these plans require Colorado Discharge Permit System (CDPS) permitting for stormwater discharges associated with construction activity.

Name of Contractor: \_\_\_\_\_

Authorized Signature: \_\_\_\_\_ Date \_\_\_\_\_

Printed Name: \_\_\_\_\_

Title: \_\_\_\_\_

Phone Number: \_\_\_\_\_

Address: \_\_\_\_\_

Email Address: \_\_\_\_\_

**Engineer's Statement**

This Engineer of Record:

The Stormwater Management Plan was prepared under my direction and supervision and is correct to the best of my knowledge and belief. Said Plan has been prepared according to the criteria established by the County and State for Stormwater Management Plans.

\_\_\_\_\_  
Andrew W. McCord

Date: \_\_\_\_\_

Engineer of Record Signature

## Table of Contents

SIGNATURE PAGES .....	2
STATE STORMWATER DISCHARGE PERMIT REQUIREMENTS .....	5
Stormwater Plan Objectives .....	4
I.    SITE DEsCRPTION.....	5
A. Nature of the Construction Activity .....	5
B. Sequence of Major Activities .....	5
C. Estimate of Area and Volume Disturbed.....	6
D. Soil Data .....	7
E. Existing Vegetation and Ground Cover.....	7
F. Potential Pollution Sources.....	7
G. Non-stormwater Discharges .....	7
H. Receiving Waters.....	7
II.   SWMP SITE MAP .....	8
III.  STORMWATER MANAGEMENT CONTROLS.....	8
A. QSM Administrator: .....	8
B. Identification of Potential Pollutant Sources: .....	8
C. Construction Control Measures (CCM) for Pollution Prevention .....	9
IV.  FINAL STABILIZATION AND LONG-TERM STORMWATER MANAGEMENT.....	14
V.   RECOMMENDED INSPECTION AND MAINTENANCE PROCEDURES .....	15
A. Self-Inspections .....	15
B. Minimum Inspection Schedule .....	15
C. Correction of Deficiencies .....	17
D. CCM Operation and Maintenance .....	17
REFERENCES .....	18
APPENDIX 1.....	19
SWMP Application.....	19
APPENDIX 2.....	20
Construction Activity Stormwater Permit .....	20
APPENDIX 3.....	21
Exhibit A - Erosion and Sediment Control Field Inspection Report .....	21
APPENDIX 4.....	22

## **State Stormwater Discharge Permit Requirements**

At least ten days prior to the anticipated start of construction activities (i.e. the initial disturbance of soils associated with clearing, grading, excavation activities, installation of structural Construction Control Measures, or other activities), for projects that will disturb one (1.0) acre or greater, the owner or operator of the construction activity must submit an application as provided by the Colorado Department of Public Health and Environment, Water Quality Control Division (Division). This form may be reproduced and is also available from the Division's web site. Applications received by the Division are processed and a permit certification and other relevant materials will be sent to the attention of the legally responsible person. The application contains certification of completion of a storm water management plan (SWMP). Do not include a copy of the Stormwater Management Plan, unless requested by the Division.

For information or application materials contact:

Colorado Department of Public Health and Environment  
Water Quality Control Division  
WQCD-P-B2  
4300 Cherry Creek Drive South  
Denver, Colorado 80246-1530

<https://www.colorado.gov/pacific/cdphe/wq-construction-general-permits>

Electronic Application – CDPHE website:

<https://www.colorado.gov/pacific/cdphe/WQ%20permits%20construction%20electronic%20application>

## **Stormwater Plan Objectives**

The objective of the Stormwater Management Plan (SWMP) is to define controls and measures to maintain water quality by eliminating or reducing pollutants in stormwater discharges during construction activities. A general schedule or phasing of Construction Control Measures (CCM) will be determined by construction schedule and ground disturbances necessitating required erosion control methods/CCM. Evaluations of and modifications to this plan may be necessary during the length of the construction project until the site is finally stabilized. This SWMP should be reviewed and modified as a part of the overall process of evaluating and managing stormwater quality issues on a regular basis. A copy of the Stormwater Discharge Permit, SWMP, SWMP Site Map (Figure 2) and inspection logs shall be kept on site by the SWMP Administrator as to be available to federal, state and local agencies for inspection.



A Construction Activities Stormwater Discharge Permit will be applied for on \_\_\_\_\_ from the Colorado Department of Public Health and Environment and is included in Appendix 1. The general conditions associated with this permit should be followed through the duration of the land disturbing activities at the site. For additional details or more specific information, consult CDPS General Permit No. COR040000 in Appendix 2.

## **I. SITE DESCRIPTION**

### **A. Nature of the Construction Activity**

Lot 1 Seder Subdivision is approximately 2.76 acres and is located on the east side of Akers Drive, north of Constitution Avue and south of Electrics Drive.

The property currently is developed and has natural vegetation. There is existing curb and gutter along the south side of the access into the site east to Marksheffel and the existing detention facility.

The existing topography consists of grades between 2 and 5 percent. Drainage patterns sheet flow across the parcel southeasterly and to the curb and gutter on the south side of the access drive to Lot 2 and ultimately to the existing detention facility.

The proposed development will consist of an addition to the existing building, addition of a paved parking area, and new retaining walls that will help level the site. Other on-site features include a new paved parking area to the west, retaining wall to the north and south to level the overall site, and landscaping.

The existing access point to the property will be maintained. The access will continue to allow access to Lot 2 as now exists.

### **B. Sequence of Major Activities**

Construction activities for the project are expected to begin in the 2nd Quarter, 2025. Prior to the commencement of the clearing and grubbing activities, minimal clearing and grubbing may be necessary prior to install the initial erosion control features such as silt fencing, safety (construction) fencing and vehicle tracking control. After the installation of the silt fences and vehicle control, clearing and grubbing will commence, and grading will proceed as shown on the SWMP Site Plan. When the finished grades are attained, the building addition, parking area, retaining walls, and landscaping will be installed. In general, the SWMP Administrator will identify the precise schedule to be used during the term of this project and include the schedule in this SWMP when available. Temporary erosion control measures are anticipated to be removed in the Winter of 2025. Temporary Control Measures (TCMs) shall not be removed until Final Stabilization has been achieved. Final Stabilization is anticipated to occur in the Summer of 2026.

**VICINITY MAP**  
**NORTHCREST CENTER**  
TBD BISMARCK ROAD  
COLORADO SPRINGS, COLORADO 80922  
EL PASO COUNTY

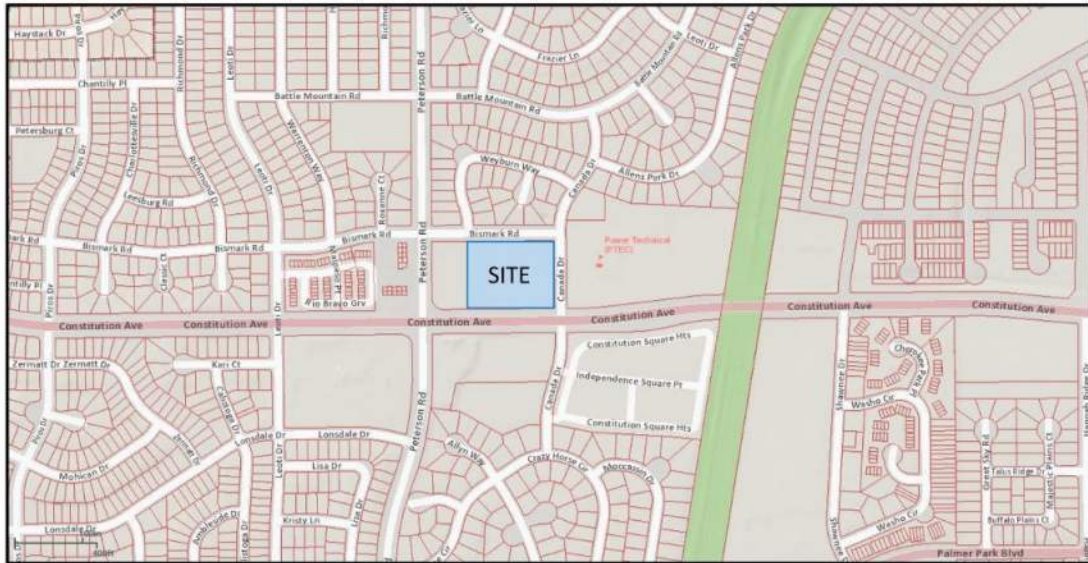

Figure 1

**C. Estimate of Area and Volume Disturbed**

The project area totals 2.76 acres of which approximately 2.38 acres will be subject to disturbance. The estimated acres of disturbance correspond to that necessary to install the building addition, parking,, sidewalks, retaining walls, and landscaping. Locations of disturbed areas are as shown on the SWMP Site Map (Figure 2). All other areas are to remain undisturbed.

Earthwork cut and fill operations are more than 500 cubic yards. Estimated earthwork is: Cut=1,900 cubic yards; Fill=1,400 cubic yards; Net Cut= 500 cubic yards.

If site was previously graded or land use was such that there is no or minimal vegetation, the % cover required for final stabilization should then be based on neighboring properties to show natural native vegetative cover (ie: an adequate reference site). If surrounding sites are also being developed, use historic aerial photos to make determination.

#### **D. Soil Data**

The soil indicative to the site is classified as Blakeland loamy sand by the USDA Soil Conservation Service and is listed as NRCS (National Resources Conservation Service) Hydrologic Soil Group A.

A subsurface soils investigation was conducted for 2725 Akers Drive, with a report entitled *Geotechnical and Pavement Report* by Entech Engineering, Inc. dated January 14, 2025.

The study found that groundwater was found in two of the test borings during field exploration.

These soils are classified within Hydrologic Soil Group A. Permeability is rapid surface runoff is slow and the hazard of erosion is moderate.

#### **E. Existing Vegetation and Ground Cover**

The total site is approximately 30% vegetated. The site slopes generally to the southeast at approximately 5%. The vegetation consists primarily of native grasses and weeds. The level of vegetative cover at the site was determined through a combination of site visits, photography, and published aerial data.

#### **F. Potential Pollution Sources**

The location of all potential pollution sources, including groundbreaking disturbing activities, vehicle fueling, storage of fertilizers or chemicals, concrete or asphalt batch plants, concrete washouts, among numerous other potential pollutants are enumerated in this SWMP. Further descriptions and locations can be found in Section III B 1 thru 13 of this report.

#### **G. Non-stormwater Discharges**

No non-stormwater components of discharge, such as springs, landscape irrigation return flows, construction dewatering or other discharges are known to exist. If any non-stormwater components of discharge are known to exist, these items will be addressed in Section III C 8 of this report. If any non-stormwater discharges become apparent during the term of construction, the occurrence and mitigation shall be addressed in an addendum by the QSM Administrator (Qualified Stormwater Manager).

SWMP Checklist Item 14. Discuss Location and description of any anticipated allowable non-stormwater discharge. Discharge of concrete wash water to ground (e.g. a concrete washout area) is an allowable non-stormwater discharge per the COR400000 Permit if properly identified in the SWMP and if the appropriate control measures are implemented. Revise discussion.

#### **H. Receiving Waters**

The project area will drain via surface flow and storm sewer facilities to a private detention facility situated at the southeast corner of the overall Seder Subdivision just west of Marksheffel Road. Runoff collected in the detention facility will be released at or below historic rates to an existing inlet along Marksheffel Road. Flows continue in pipe and are released into Sand Creek, which drains to Fountain Creek, which in turn drains to the Arkansas River.

## **II. SWMP SITE MAP**

The Stormwater Management Plan Site Map (Figure 2) is included in Appendix 4 and identifies the following:

- A. Construction site boundaries;
- B. All areas of ground disturbance;
- C. Areas of cut and fill;
- D. Areas used for storage of building materials, equipment, soil, or waste;
- E. Locations of dedicated asphalt or concrete batch plants;
- F. Locations of all structural CCM;
- G. Locations of non-structural CCM where applicable;
- H. Locations of springs, streams, wetlands, detention basins, irrigation canals, roadside ditches and other surface waters.

The SWMP Site Map must be updated by the SWMP Administrator on a regular basis to reflect current conditions of the site at all times.

## **III. STORMWATER MANAGEMENT CONTROLS**

### **A. QSM Administrator:**

QSM Administrator: \_\_\_\_\_ Phone: (\_\_\_\_)\_\_\_\_\_. The QSM Administrator will likely be the Contractor or his/her designated representative and is responsible for developing, implementing, maintaining and revising the SWMP. Should the QSM Administrator change for any reason, it shall be noted on this Plan.

### **B. Identification of Potential Pollutant Sources:**

At a minimum, the following activities and sources shall be evaluated for the potential to contribute pollutants to stormwater discharges. The SWMP Administrator shall determine the need for and locations of each of the following potential pollutant sources during the course of the construction project. There are no stream crossings impacting or traversing the property.

The sources of any potential pollutants must be controlled through CCM selection and implementation:

- 1. All disturbed and stored soils;
- 2. Vehicle tracking of sediments;
- 3. Management of contaminated soils;
- 4. Loading and unloading operations;
- 5. Outdoor storage activities (building materials, fertilizers, chemicals, etc.);
- 6. Vehicle and equipment maintenance and fueling;
- 7. Significant dust or particulate generating processes shall be controlled by sprinkling with water and other appropriate means;
- 8. Routine maintenance activities involving fertilizers, pesticides, detergents, fuels, solvents, oils, etc.
- 9. On-site waste management practices such as waste piles, liquid wastes, dumpsters, etc.

10. Concrete truck/equipment washing, including the concrete truck chute and associated fixtures and equipment;
11. Dedicated asphalt and concrete batch plants;
12. Non-industrial waste sources such as worker trash and portable toilets; and
13. Any other areas or procedures where potential spills could occur.

sediment control logs are also proposed

### C. Construction Control Measures (CCM) for Pollution Prevention

1. Structural practices for erosion and sediment control implemented on the site to minimize erosion and sediment are shown on sheet C300 to C305 and are as follows:

Structural practices to be used on-site are, silt fences, rock socks, inlet/outlet protection, concrete washout area, stabilized staging area, stockpile management, portable toilet, vehicle tracking control and a temporary sediment basin. Show TSB on GEC Plan

Minimal clearing and grubbing may be necessary prior to installing the initial erosion control features such as silt fences and vehicle tracking control. Prior to any construction activities, silt fences around proposed grading areas as shown on attached Sheet C301 will be installed. Vehicle tracking control will be installed to manage sedimentation from construction vehicles exiting the site. Inlet protection will be installed to filter stormwater before entering any watercourses. Final stabilization is anticipated to occur during Summer 2026.

2. Non-structural practices for erosion and sediment control to be used to minimize erosion and sediment transport are:

Temporary and permanent vegetation, mulching, geotextiles, sod stabilization, protection of trees and preservation of mature vegetation.

Minimize the amount of existing vegetation to be removed during construction, leaving native vegetation in place when possible. Only the existing vegetation that is specified or requiring removal shall be disturbed or removed. If possible, leave existing ground cover, including asphalt in place or remove just prior to grading to minimize the length of soil exposure.

3. Phased CCM Implementation:

Minimal clearing and grubbing may be necessary prior to installing the initial erosion control features such as silt fences and vehicle tracking control. Prior to any construction activities, silt fences around proposed grading areas as shown on the SWMP Site Plan will be installed. Vehicle tracking control will be installed to manage sediment from construction vehicles exiting the site. Inlet protection and rock socks will be installed to filter stormwater before entering the storm sewer systems.

4. Materials handling and spill prevention:

The site superintendent will inspect daily to ensure proper use and disposal of materials on-site including building materials, paints, solvents, fertilizers, chemicals, waste materials and equipment maintenance or fueling procedures. All materials stored on-site will be stored in a neat and orderly manner in the original containers with the original manufacturer's label, and if possible, under a roof or other enclosure. Before disposing of the container, all of a product will be used up whenever possible and manufacturer's recommendations for proper disposal will be followed according to state and local regulations. Material and equipment necessary for spill cleanup will be kept in the material storage area on-site. Manufacturer's recommendations for spill cleanup will be posted and site personnel will be made aware of the procedures along with the location of the information and cleanup supplies.

Building Material Handling and Staging Areas: Paints, solvents, pesticides, fuels and oils, other hazardous materials or building materials that have the potential to contaminate stormwater should be stored indoors or under cover whenever possible or in areas with secondary containment. Secondary containment measures prevent a spill from spreading across the site and may include dikes, berms, curbing, or other containment methods. Secondary containment techniques should also ensure the protection of groundwater. Designate staging areas for activities such as fueling vehicles, mixing paints, plaster, mortar, and other potential pollutants. Designated staging areas enable easier monitoring of the use of materials and clean up of spills. Training employees and subcontractors is essential to the success of this pollution prevention principle. The following specific materials handling and staging practices should be used:

- a) Train employees and subcontractors in proper handling and storage practices.
- b) Clearly designate site areas for staging and storage with signs and on construction drawings. Staging areas should be located in areas central to the construction site. Segment the staging area into sub-areas designated for vehicles, equipment, or stockpiles. Construction entrances and exits should be clearly marked so that delivery vehicles enter/exit through stabilized areas with vehicle tracking controls (See Vehicle Tracking Control).
- c) Provide storage in accordance with Spill Protection, Control and Countermeasures (SPCC) requirements and plans and provide cover and impermeable perimeter

control, as necessary, for hazardous materials and contaminated soils that must be stored on site.

- d) Ensure that storage containers are regularly inspected for leaks, corrosion, support or foundation failure, or other signs of deterioration and tested for soundness.
- e) Reuse and recycle construction materials when possible.

Vehicle Fueling and Maintenance Practices: Create a clearly designated on-site fueling and maintenance area that is clean and dry. The on-site fueling area should have a spill kit, and staff should know how to use it. If possible, conduct vehicle fueling and maintenance activities in a covered area. The following practices to help prevent the discharge of pollutants to stormwater from equipment/vehicle fueling and maintenance should be used:

- a) Train employees and subcontractors in proper fueling procedures (stay with vehicles during fueling, proper use of pumps, emergency shutoff valves, etc.).
- b) Inspect on-site vehicles and equipment regularly for leaks, equipment damage, and other service problems.
- c) Clearly designate vehicle/equipment service areas away from drainage facilities and watercourses to prevent stormwater run-on and runoff.
- d) Use drip pans, drip cloths, or absorbent pads when replacing spent fluids.
- e) Collect all spent fluids, store in appropriate labeled containers in the proper storage areas, and recycle fluids whenever possible.

Spill Prevention and Response: Representative procedures include identifying ways to reduce the chance of spills, stop the source of spills, contain and clean up spills, dispose of materials contaminated by spills, and train personnel responsible for spill prevention and response. The following material handling procedures and storage requirements should be used to ensure that clear and concise spill cleanup procedures are provided and posted for areas in which spills may potentially occur:

- a) Note the locations of chemical storage areas, storm drains, tributary drainage areas, surface waterbodies on or near the site, and measures to stop spills from leaving the site.

- b) Provide proper handling and safety procedures for each type of waste. Keep Material Safety Data Sheets (MSDSs) for chemical used on site.
- c) Establish an education program for employees and subcontractors on the potential hazards to humans and the environment from spills and leaks.
- d) Specify how to notify appropriate authorities, such as police and fire departments, hospitals, or municipal sewage treatment facilities to request assistance. Emergency procedures and contact numbers should be provided and posted at storage locations.
- e) Use proper procedures, equipment and materials for immediate cleanup of spills and proper disposal.
- f) Identify personnel responsible for implementing the plan in the event of a spill. Update the spill prevention plan and clean up materials as changes occur to the types of chemicals stored and used at the facility.

5. Concrete and asphalt batch plants:

Dedicated concrete or asphalt batch plants are not anticipated to be used.

6. Vehicle tracking control:

Off-site vehicle tracking of sediment shall be minimized and is as shown on the CSWMP Site Map. Streets shall be kept clean and free of mud, soil and construction waste. Street sweeping or other acceptable methods shall be used to prevent sediment from being washed from the project site. Streets shall not be washed down with water. Street cleaning operations shall occur, if necessary or as directed by the County.

7. Waste management and disposal including concrete washout:

A concrete washout area shall be specified in a location near concrete work areas. Concrete wash water shall not be discharged to state waters or to storm sewer systems. The washout area shall be a shallow excavation with a small perimeter berm to isolate concrete truck washout operations. At the end of construction, all concrete shall be removed from the site and disposed of at an approved waste site. Signs shall be placed at the washout to clearly indicate the concrete washout area to operators of concrete trucks and pump rigs.

All construction site waste both liquid and solid must be contained in approved waste containers and disposed of off-site according to state and local regulations. Locations are unknown at this time but will be shown on the SWMP Site Map when determined. Portable sanitary facilities shall be provided at the site throughout the construction phase.



Portable Toilets (PT) will be located a minimum of 10ft from stormwater inlets and 50ft from State Waters. They will be secured at all four corners to prevent overturning and cleaned on a weekly basis. They will be inspected daily for spills.

Waste Disposal Bins shall be inspected daily and emptied each week at a minimum. Full or overflowing waste bins shall not be left uncovered overnight.

8. Groundwater and stormwater dewatering:

Groundwater and/or stormwater dewatering is not anticipated on this site.

9. Self-Inspections:

The QSM Administrator is required to conduct self-inspections. The purpose of these inspections is to ensure that all Control Measures are installed according to the approved plans, appropriate as to the intended use, operating effectively, and being properly maintained. The GEC Administrator must be qualified according to Chapter 2, Section 5.0 of the Stormwater Construction Manual.

The QSM Administrator shall, at a minimum, make a thorough inspection at least once every 14 calendar days. Also, post-storm event inspections must be conducted within 24 hours following the end of any precipitation or snowmelt event that causes surface erosion. Provided the timing is appropriate, the post-storm inspections may be used to fulfill the 14-day routine inspection requirement. Alternatively, the QSM Administrator may choose to perform self-inspections every 7 calendar days and forego post-storm event inspections. The self-inspection schedule must be identified in the QSM Administrator's most recent self-inspection. A more frequent inspection schedule than the minimum described may be necessary to ensure that Control Measures continue to operate as needed to comply with the GEC Plan. Site conditions such as steep grades and close proximity to a state water are reasons for increasing the frequency of self-inspections.

The QSM Administrator shall submit documentation of the self-inspections by uploading the document to the County's Electronic Permitting Management System. **Completed self-inspection forms must be submitted electronically within 5 business days of the self-inspection.** The self-inspections must also be available either physically or electronically at the construction site at all times throughout the duration of the project. Inspectors will review self-inspections during compliance inspections. The use of a third-party inspection program does not remove this requirement. Additionally, the use of a third-party inspection program does not relieve the Permittee of the requirement to comply with all compliance inspections.

For sites or portions of sites where construction activities have been completed and final stabilization measures installed but final stabilization has not yet been achieved, the QSM Administrator shall make a thorough inspection of their Control Measures at least once every month. Post-storm event inspections must be conducted within 72 hours following the end of any precipitation or snowmelt event that causes surface erosion. The GEC Plan must be amended to indicate those areas where construction activities have been completed but final stabilization has not yet been achieved that will be inspected once a month.

When site conditions make the schedule required in this section impractical, the permittee may petition the County to grant an alternate inspection schedule. The alternative inspection schedule may not be implemented prior to written approval by the County and incorporation into the SWMP.

The Permittee is responsible to confirm that the frequency of inspections is sufficient to ensure that Control Measures remain in good working condition at all times.

#### **IV. FINAL STABILIZATION AND LONG-TERM STORMWATER MANAGEMENT**

Final stabilization is anticipated to occur during Summer 2026. Final stabilization is reached when all soil disturbing activities at the site have been completed and uniform vegetative cover has been established with a density of at least 70 percent of pre-disturbance levels, or equivalent permanent, physical erosion reductions have been employed. For the purposes of the SWMP, establishment of a vegetative cover capable of providing erosion control equivalent to pre-existing conditions at the site can be considered final stabilization. The contractor will be responsible for providing the documentation to make this comparison to the State of Colorado, Water Quality Control Division.

The project site shall be seeded with the seed mix as shown on the SWMP CCM Details (Sheet C304), where the application methods and soil preparations are also found. All slopes greater (steeper) than three-to-one will be covered with erosion control blankets.

Management of storm water after completion of construction will be accomplished by utilizing the practices listed below.

- Upon completion of construction, the site shall be inspected to ensure that all equipment, waste materials and debris have been removed.
- The site will be inspected to make certain that all graded surfaces have been paved, landscaped, or seeded with an appropriate ground cover.

Address long-term stormwater quality. This site is being treated by an existing water quality facility.

- All silt fence, inlet protection, sediment logs, curb socks and all other control practices and measures that are to remain after completion of construction will be inspected to ensure their proper functioning.
- The contractor shall remove erosion control measures that are not required to remain.

After all construction activities are completed on the site, but final stabilization has not been achieved, the contractor shall make a thorough inspection of the stormwater management system at least once every month.

The contractor shall be responsible for maintaining the storm water controls in good working order and shall also be responsible for the costs incurred until such time as final stabilization is reached. Once final stabilization has been achieved the contractor shall be responsible for removal of the erosion control measures.

Should any of the erosion control facilities come into disrepair prior to the establishment of the native or natural erosion control measures, the Contractor is responsible for the cost of such maintenance. The Contractor is also responsible for the clean up of offsite areas affected by any sediment that may leave the site. Control of erosion from areas disturbed by utility or building construction will be the responsibility of the respective contractor. All erosion control measures shown on the plan shall be installed and maintained in accordance with Construction Control Measures.

## **V. RECOMMENDED INSPECTION AND MAINTENANCE PROCEDURES**

### **A. Self-Inspections**

Self-inspections shall be conducted by the qualified QSM Administrator. These inspections are to ensure that all Control Measures are installed according to the approved plans, appropriate as to the intended use, operating effectively, and being properly maintained.

### **B. Minimum Inspection Schedule**

- a) **Frequency.** Contractor should inspect Construction CCM's at the following times and intervals.
  - (1) After installation of any Construction CCM;
  - (2) Post storm inspections -- within 24 hours after any runoff event (rainfall or snowmelt) that causes surface erosion;
  - (3) Routine inspections -- at a minimum once every 14 days, but a more frequent inspection schedule may be necessary to ensure that CCM continue to operate as needed to comply with the permit. Post storm inspections may be used to fulfill routine inspections.

- (4) Alternate inspection schedule -- perform self-inspections every 7 calendar days and forego post-storm event inspections.
- (5) A more frequent inspection schedule than the minimum described may be necessary to ensure that Control Measures continue to operate as needed to comply with the GEC Plan. Site conditions such as steep grades and close proximity to a state water are reasons for increasing the frequency of self-inspections.
- (6) Construction activities have been completed and final stabilization measures installed but final stabilization has not yet been achieved -- the GEC Administrator shall make a thorough inspection of their Control Measures at least once every month. Post-storm event inspections must be conducted within 72 hours following the end of any precipitation or snowmelt event that causes surface erosion. The GEC Plan must be amended to indicate those areas where construction activities have been completed but final stabilization has not yet been achieved that will be inspected once a month.
- (7) When site conditions make the schedule required in this section impractical, the permittee may petition the County to grant an alternate inspection schedule. The alternative inspection schedule may not be implemented prior to written approval by the County and incorporation into the SWMP.
- (8) The Permittee is responsible to confirm that the frequency of inspections is sufficient to ensure that Control Measures remain in good working condition at all times.
- (9) Consult Permit No. COR040000 for alternate inspection requirements at temporarily idle sites, at completed sites, or for winter conditions.

b) **Inspection Log.** The QSM Administrator should record the inspection results on a site-specific standardized inspection log to be maintained and kept on the construction site, for review by agencies. The QSM Administrator shall submit documentation of the self-inspections by uploading the document to the County's Electronic Permitting Management System. Completed self-inspection forms must be submitted electronically within 5 business days of the self-inspection. The self-inspections must also be available either physically or electronically at the construction site at all times throughout the duration of the project. Inspectors will review self-inspections during compliance inspections. The use of a third-party inspection program does not remove this requirement. Additionally, the use of a third-party inspection program does not relieve the Permittee of the requirement to comply with all compliance inspections.

c) A template for the inspection log format is included in Appendix 3. The QSM Administrator should develop site-specific inspection logs that itemize the selected Construction CCM's for their site. At a minimum the following information from each inspection should be recorded on the site-specific log:

- (1) Date of Inspection;
- (2) Name and title and signature of inspector;
- (3) Self-inspection schedule;
- (4) Location(s) of discharges of sediment or other pollutants from the site;

- (5) Location(s) of CCM that need to be maintained;
- (6) Location(s) of CCM that failed to operate as designed or proved inadequate for a particular location;
- (7) Location(s) where additional CCM are needed that were not in place at the time of inspection;
- (8) Deviations from the minimum inspection schedule as provided in the permit;
- (9) Descriptions of corrective actions for any item above, date(s) of corrective actions taken, and measures taken to prevent future violations, including requisite changes to the SWMP, as necessary and
- (10) After corrective action(s) have been taken, or where a report does not identify any incidents requiring corrective actions, the report shall contain a signed statement indicating the site is in compliance with the permit to the best of the signer's knowledge and belief.

### **C. Correction of Deficiencies**

The Permittee and QSM Administrator are responsible to ensure and document that Control Measures are maintained when and where deficiencies have been noted on self-inspections. When Control Measures have failed as determined by the QSM Administrator, they must be addressed as soon as possible, immediately in most cases, to minimize the discharge of pollutants. All issues must ultimately be resolved within 3 calendar days after the noncompliance issue is first identified.

### **D. CCM Operation and Maintenance.**

The QSM Administrator is responsible for operation and maintenance of construction CCM. The QSM Administrator will inspect the site per inspection and monitoring protocol outlined above and make any necessary repairs to construction CCM immediately after a defect or other need for repair is discovered. The project site and the adjacent streets impacted by the construction shall be kept neat, clean, and free of debris. The erosion control measures and facilities will be maintained in good working order until final stabilization. Any items that are not functioning properly or are inadequate will be promptly repaired or upgraded. Records of inspections must be kept and be available for review by the State of Colorado Water Quality Control Division or the County.

The SWMP should be viewed as a 'living document' that is continuously being reviewed and modified as a part of the overall process of evaluating and managing Stormwater issues at the site. The QSM shall amend the SWMP when there is a change in design, construction, or Operating & Maintenance of the site which would require the implementation of new or revised BMPs or if the SWMP proves to be ineffective in achieving the general objectives of controlling pollutants in stormwater discharges associated with construction activities, or when BMPs are no longer necessary and could be removed.

This project does not rely on control measures owned or operated by others.

## REFERENCES

The following reports and plans were used in the process of preparing this Stormwater Management Plan:

1. *CDPS General Permit: Stormwater Discharges Associated with Construction Activity Permit No. COR040000*. Colorado Department of Public Health and Environment. January 21, 2021.
2. *Final Drainage Report – Peaceful Valley Subdivision Prepared by: Kiowa Engineering Corporation [No. 04092], July 20, 2006*
3. *West Fork Jimmy Camp Creek Drainage Basin Planning Study, prepared by Kiowa Engineering Corporation, dated October 17, 2003.*
4. *City of Colorado Springs and El Paso County Flood Insurance Study, prepared by the Federal Emergency Management Agency, dated March 1997.*
5. *El Paso County Drainage Criteria Manual (Volumes 1 and 2) and Engineering Criteria Manual, current editions.*
6. *Soil Survey of El Paso County Area, Colorado, prepared by United States Department of Agriculture Soil Conservation Service, dated June 1981.*

**APPENDIX 1**  
**SWMP Application**

**APPENDIX 2**

**Construction Activity Stormwater Permit**





# STATE OF COLORADO

## COLORADO DEPARTMENT OF PUBLIC HEALTH AND ENVIRONMENT

### Water Quality Control Division

CDPS GENERAL PERMIT STORMWATER DISCHARGES ASSOCIATED WITH  
CONSTRUCTION ACTIVITY AUTHORIZATION TO DISCHARGE UNDER THE COLORADO DISCHARGE PERMIT SYSTEM (CDPS)  
**COR400000**

In compliance with the provisions of the Colorado Water Quality Control Act, (25-8-101 et seq., CRS, 1973 as amended) and the Federal Water Pollution Control Act, as amended (33 U.S.C. 1251 et seq.; the "Act"), this permit authorizes the discharge of stormwater associated with construction activities (and specific allowable non-stormwater discharges in accordance with Part I.A.1. of the permit) certified under this permit, from those locations specified throughout the State of Colorado to specified waters of the State.

Such discharges shall be in accordance with the conditions of this permit. This permit specifically authorizes the facility listed on the certification to discharge in accordance with permit requirements and conditions set forth in Parts I and II hereof. All discharges authorized herein shall be consistent with the terms and conditions of this permit.

This permit becomes effective on April 1, 2019, and shall expire at midnight March 31, 2024.

Issued and signed this 28th day of January, 2021.

*Meg Parish*

Meg Parish, Permits Section Manager Water Quality Control Division

COLORADO DEPARTMENT OF PUBLIC HEALTH AND ENVIRONMENT

#### Permit History

Minor Modification Issued January 28, 2021 Effective February 1, 2021

Modification Issued December 31, 2020 Effective February 1, 2021

Originally signed and issued October 31, 2018; effective April 1, 2019

Table of Contents

PART I ..... 3

    A. COVERAGE UNDER THIS PERMIT ..... 3

        1. Authorized Discharges..... 3

        2. Limitations on Coverage ..... 3

        3. Permit Certification and Submittal Procedures ..... 4

    B. EFFLUENT LIMITATIONS ..... 8

        1. Requirements for Control Measures Used to Meet Effluent Limitations..... 8

        2. Discharges to an Impaired Waterbody..... 11

        3. General Requirements ..... 12

    C. STORMWATER MANAGEMENT PLAN (SWMP) REQUIREMENTS..... 12

        1. SWMP General Requirements ..... 12

        2. SWMP Content ..... 13

        3. SWMP Review and Revisions..... 15

        4. SWMP Availability ..... 16

    D. SITE INSPECTIONS ..... 16

        1. Person Responsible for Conducting Inspections ..... 16

        2. Inspection Frequency..... 16

        3. Inspection Frequency for Discharges to Outstanding Waters..... 17

        4. Reduced Inspection Frequency ..... 17

        5. Inspection Scope ..... 17

    E. DEFINITIONS..... 19

    F. MONITORING ..... 22

    G. OIL AND GAS CONSTRUCTION ..... 22

PART II: STANDARD PERMIT CONDITIONS ..... 24

    A. DUTY TO COMPLY ..... 24

    B. DUTY TO REAPPLY ..... 24

    C. NEED TO HALT OR REDUCE ACTIVITY NOT A DEFENSE..... 24

    D. DUTY TO MITIGATE ..... 24

    E. PROPER OPERATION AND MAINTENANCE ..... 24

    F. PERMIT ACTIONS..... 24

    G. PROPERTY RIGHTS ..... 24

    H. DUTY TO PROVIDE INFORMATION ..... 25

    I. INSPECTION AND ENTRY ..... 25

    J. MONITORING AND RECORDS ..... 25

    K. SIGNATORY REQUIREMENTS ..... 26

        1. Authorization to Sign: ..... 26

        2. Electronic Signatures ..... 26

3. Change in Authorization to Sign .....	26
L. REPORTING REQUIREMENTS .....	27
1. Planned Changes .....	27
2. Anticipated Non-Compliance.....	27
3. Transfer of Ownership or Control .....	27
4. Monitoring reports .....	27
5. Compliance Schedules .....	27
6. Twenty-four Hour Reporting .....	28
7. Other Non-Compliance .....	28
8. Other Information.....	28
M. BYPASS.....	28
1. Bypass Not Exceeding Limitations.....	28
2. Notice of Bypass.....	28
3. Prohibition of Bypass .....	28
N. UPSET .....	29
1. Effect of an upset.....	29
2. Conditions Necessary for Demonstration of an Upset .....	29
3. Burden of Proof .....	29
O. RETENTION OF RECORDS .....	29
1. Post-Expiration or Termination Retention.....	29
2. On-site Retention .....	29
P. REOPENER CLAUSE .....	30
1. Procedures for Modification or Revocation.....	30
2. Water Quality Protection .....	30
Q. SEVERABILITY .....	30
R. NOTIFICATION REQUIREMENTS.....	30
1. Notification to Parties .....	30
S. RESPONSIBILITIES .....	30
1. Reduction, Loss, or Failure of Treatment Facility .....	30
T. OIL AND HAZARDOUS SUBSTANCE LIABILITY.....	30
U. EMERGENCY POWERS .....	31
V. CONFIDENTIALITY .....	31
W. FEES .....	31
X. DURATION OF PERMIT .....	31
Y. SECTION 307 TOXICS.....	31

## Part I

Note: At the first mention of terminology that has a specific connotation for the purposes of this permit, the terminology is electronically linked to the definitions section of the permit in Part I.E.

### A. COVERAGE UNDER THIS PERMIT

#### 1. Authorized Discharges

This general permit authorizes permittee(s) to discharge the following to state waters: stormwater associated with construction activity and specified non-stormwater associated with construction activity. The following types of stormwater and non-stormwater discharges are authorized under this permit:

##### a. Allowable Stormwater Discharges

- i. Stormwater discharges associated with construction activity.
- ii. Stormwater discharges associated with producing earthen materials, such as soils, sand, and gravel dedicated to providing material to a single contiguous site, or within ¼ mile of a construction site (e.g. borrow or fill areas).
- iii. Stormwater discharges associated with [dedicated asphalt](#), [concrete batch plants](#) and [masonry mixing stations](#) (Coverage under this permit is not required if alternative coverage has been obtained.)

##### b. Allowable Non-Stormwater Discharges

The following non-stormwater discharges are allowable under this permit if the discharges are identified in the stormwater management plan in accordance with [Part I.C](#) and if they have appropriate [control measures](#) in accordance with [Part I.B.1](#).

- i. Discharges from uncontaminated springs that do not originate from an area of land disturbance.
- ii. Discharges to the ground of concrete washout water associated with the washing of concrete tools and concrete mixer chutes. Discharges of concrete washout water must not leave the site as surface runoff or reach [receiving waters](#) as defined by this permit. Concrete on-site waste disposal is not authorized by this permit except in accordance with [Part I.B.1.a.ii\(b\)](#).
- iii. Discharges of landscape irrigation return flow.
- iv. Discharges from [diversions](#) of state waters within the permitted site.

##### c. Emergency Fire Fighting

Discharges resulting from emergency firefighting activities during the active emergency response are authorized by this permit.

#### 2. Limitations on Coverage

Discharges not authorized by this permit include, but are not limited to, the discharges and activities listed below. Permittees may seek individual or alternate general permit coverage for the discharges, as appropriate and available.

##### a. Discharges of Non-Stormwater

Discharges of non-stormwater, except the authorized non-stormwater discharges listed in Part

I.A.1.b., are not eligible for coverage under this permit.

- b. Discharges Currently Covered by another Individual or General Permit
- c. Discharges Currently Covered by a Water Quality Control Division (division) Low Risk Guidance Document

### 3. Permit Certification and Submittal Procedures

#### a. Duty to Apply

The following activities shall apply for coverage under this permit:

- i. Construction activity that will disturb one acre or more; or
- ii. Construction activity that is part of a [common plan of development or sale](#); or
- iii. Stormwater discharges that are designated by the division as needing a stormwater permit because the discharge:
  - (a) Contributes to a violation of a water quality standard; or
  - (b) Is a significant contributor of [pollutants](#) to state waters.

#### b. Application Requirements

To obtain authorization to discharge under this permit, applicants applying for coverage following the effective date of the renewal permit shall meet the following requirements:

- i. Owners and operators submitting an application for permit coverage will be co-permittees subject to the same benefits, duties, and obligations under this permit.
- ii. Signature requirements: Both the [owner](#) and [operator](#) (permittee) of the construction site, as defined in Part I.E., must agree to the terms and conditions of the permit and submit a completed application that includes the signature of both the owner and the operator. In cases where the duties of the owner and operator are managed by the owner, both application signatures may be completed by the owner. Both the owner and operator are responsible for ensuring compliance with all terms and conditions of the permit, including implementation of the stormwater management plan.
- iii. The applicant(s) must develop a stormwater management plan (SWMP) in accordance with the requirements of Part I.C. The applicant(s) must also certify that the SWMP is complete, or will be complete, prior to commencement of any construction activity.
- iv. In order to apply for certification under this general permit, the applicant(s) must submit a complete, accurate, and signed permit application form as provided by the division by electronic delivery at least 10 days prior to the commencement of construction activity, except those construction activities that are in response to a [public emergency related site](#); [public emergency related sites](#) shall apply for coverage no later than 14 days after the commencement of construction activities. The provisions of this part in no way remove a violation of the Colorado Water Quality Control Act if a [point source](#) discharge occurs prior to the issuance of a CDPS permit.
- v. The application in its entirety must be submitted via the division's online permitting system unless a waiver is granted by the division. If a waiver is granted, the application in its entirety, including signatures by both the owner and operator, must be submitted to:

Colorado Department of Public Health and Environment  
Water Quality Control Division  
Permits Section, WQCD-PS-B2  
4300 Cherry Creek Drive South  
Denver, CO 80246

- vi. The applicant(s) must receive written notification that the division granted permit coverage prior to conducting construction activities except for construction activities that are in response to a public emergency related site.

c. Division Review of Permit Application

Within 10 days of receipt of the application, and following review of the application, the division may:

- i. Issue a certification of coverage;
- ii. Request additional information necessary to evaluate the discharge;
- iii. Delay the authorization to discharge pending further review;
- iv. Notify the applicant that additional terms and conditions are necessary; or
- v. Deny the authorization to discharge under this general permit.

d. Alternative Permit Coverage

i. Division Required Alternative Permit Coverage:

The division may require an applicant or permittee to apply for an individual permit or an alternative general permit if it determines the discharge does not fall under the scope of this general permit, including if any additional terms and conditions are necessary in order to ensure that discharges authorized by this permit shall not cause, have the reasonable potential to cause, or measurably contribute to an exceedance of any applicable water quality standard, including narrative standards for water quality. In this case, the division will notify the applicant or permittee that an individual permit application is required.

ii. Permittee Request for Alternative Permit Coverage:

A permittee authorized to discharge stormwater under this permit may request to be excluded from coverage under this general permit by applying for an individual permit. In this case, the permittee must submit an individual application, with reasons supporting the request, to the division at least 180 days prior to any discharge. When an individual permit is issued, the permittee's authorization to discharge under this permit is terminated on the effective date of the individual permit.

e. Submittal Signature Requirements

Documents required for submittal to the division in accordance with this permit, including applications for permit coverage and other documents as requested by the division, must include signatures by **both** the owner and the operator, except for instances where the duties of the owner and operator are managed by the owner.

Signatures on all documents submitted to the division as required by this permit must meet the Standard Signatory Requirements in [Part II.K](#) of this permit in accordance with 40 C.F.R. 122.41(k).

i. Signature Certification

Any person(s) signing documents required for submittal to the division must make the following

certification:

“I certify under penalty of law that this document and all attachments were prepared under my direction or supervision in accordance with a system designed to assure that qualified personnel properly gather and evaluate the information submitted. Based on my inquiry of the person or persons who manage the system, or those persons directly responsible for gathering the information, the information submitted is, to the best of my knowledge and belief, true, accurate, and complete. I am aware that there are significant penalties for submitting false information, including the possibility of fine and imprisonment for knowing violations.”

f. Compliance Document Signature Requirements

Documents which are required for compliance with the permit, but for which submittal to the division is not required unless specifically requested by the division, must be signed by the individual(s) designated as the [Qualified Stormwater Manager](#), as defined in Part I.E.

- i. Any person(s) signing inspection documents required for compliance with the permit per [Part I.D.5.c.xiii](#) must make the following statement and provide the date of the statement:

“I verify that, to the best of my knowledge and belief, that if any corrective action items were identified during the inspection, those corrective actions are complete, and the site is currently in compliance with the permit.”

g. Field Wide Permit Coverage for Oil and Gas Construction

At the discretion of the division, a single permit certification may be issued to a single oil and gas permittee to cover construction activity related discharges from an oil and gas field at multiple locations that are not necessarily contiguous.

h. Permit Coverage without Application

**Qualifying Local Program:** When a small construction site is within the jurisdiction of a qualifying local program, the owner and operator of the construction activity are authorized to discharge stormwater associated with **small construction activity** under this general permit without the submittal of an application to the division. Sites covered by a qualifying local program are exempt from the following sections of this general permit: Part I.A.3.a.; Part I.A.3.b.; Part I.A.3.c.; Part I.A.3.d.; Part I.A.3.g.; Part I.A.3.i.; Part I.A.3.j.; Part I.A.3.k.

Sites covered by a qualifying local program are subject to the following requirements:

- i. **Local Agency Authority:** This permit does not pre-empt or supersede the authority of local agencies to prohibit, restrict, or control discharges of stormwater to storm drain systems or other water courses within their jurisdiction.
- ii. **Permit Coverage Termination:** When a site under a Qualifying Local Program is finally stabilized, coverage under this permit is automatically terminated.
- iii. **Compliance with Qualifying Local Program:** Qualifying Local Program requirements that are equivalent to the requirements of this permit are incorporated by reference. Permittees authorized to discharge under this permit, must comply with the equivalent requirements of the Qualifying Local Program that has jurisdiction over the site as a condition of this permit.
- iv. **Compliance with Remaining Permit Conditions.** Requirements of this permit that are in addition to or more stringent than the requirements of the Qualifying Local Program apply in addition to the requirements of the Qualifying Local Program.
- v. **Written Authorization of Coverage:** The division or local municipality may require any permittee within the jurisdiction of a Qualifying Local Program covered under this permit to

apply for, and obtain written authorization of coverage under this permit. The permittee must be notified in writing that an application for written authorization of coverage is required.

i. Permittee Initiated Permit Actions

Permittee initiated permit actions, including but not limited to modifications, contact changes, transfers, and terminations, shall be conducted following [Part II.L](#), division guidance and using appropriate division-provided forms.

j. Sale of Residence to Homeowner

**Residential construction sites only:** The permittee may remove residential lots from permit coverage once the lot meets the following criteria:

- i. The residential lot has been sold to the homeowner(s) for private residential use;
- ii. A certificate of occupancy, or equivalent, is maintained on-site and is available during division inspections;
- iii. The lot is less than one acre of disturbance;
- iv. All construction activity conducted on the lot by the permittee is complete;
- v. The permittee is not responsible for final stabilization of the lot; and
- vi. The SWMP was modified to indicate the lot is no longer part of the construction activity.

If the residential lot meets the criteria listed above then activities occurring on the lot are no longer considered to be construction activities with a duty to apply and maintain permit coverage. Therefore, the permittee is not required to meet the final stabilization requirements and may terminate permit coverage for the lot.

k. Permit Expiration and Continuation of Permit Coverage

Authorization to discharge under this general permit shall expire at midnight on March 31, 2024. While Regulation 61.4 requires a permittee to submit an application for continuing permit coverage 180 days before the permit expires, the division is requiring that permittees desiring continued coverage under this general permit must reapply at least 90 days in advance of this permit expiration. The division will determine if the permittee may continue to discharge stormwater under the terms of the general permit. An individual permit may be required for any facility not reauthorized to discharge under the reissued general permit.

If this permit is not reissued or replaced prior to the expiration date, it will be administratively continued and remain in force and effect. For permittees that have applied for continued permit coverage, discharges authorized under this permit prior to the expiration date will automatically remain covered by this permit until the earliest of:

- i. An authorization to discharge under a reissued permit, or a replacement of this permit, following the timely and appropriate submittal of a complete application requesting authorization to discharge under the new permit and compliance with the requirements of the new permit; or
- ii. The issuance and effect of a termination issued by the division; or
- iii. The issuance or denial of an individual permit for the facility's discharges; or
- iv. A formal permit decision by the division not to reissue this general permit, at which time the division will identify a reasonable time period for covered dischargers to seek coverage under



an alternative general permit or an individual permit. Coverage under this permit will cease when coverage under another permit is granted/authorized; or

- v. The division has informed the permittee that discharges previously authorized under this permit are no longer covered under this permit.

## B. EFFLUENT LIMITATIONS

### 1. Requirements for Control Measures Used to Meet Effluent Limitations

The permittee must implement control measures to [minimize](#) the discharge of pollutants from all potential pollutant sources at the site. Control measures must be installed prior to commencement of construction activities. Control measures must be selected, designed, installed and maintained in accordance with [good engineering, hydrologic and pollution control practices](#). Control measures implemented at the site must be designed to prevent pollution or degradation of state waters.

#### a. Stormwater Pollution Prevention

The permittee must implement structural and/or nonstructural control measures that effectively minimize erosion, sediment transport, and the release of other pollutants related to construction activity.

##### i. Control Measures for Erosion and Sediment Control

Control measures for erosion and sediment control may include, but are not limited to, wattles/sediment control logs, silt fences, earthen dikes, drainage swales, sediment traps, subsurface drains, pipe slope drains, inlet protection, outlet protection, gabions, sediment basins, temporary vegetation, permanent vegetation, mulching, geotextiles, sod stabilization, slope roughening, maintaining existing vegetation, protection of trees, and preservation of mature vegetation.

Specific control measures must meet the requirements listed below.

- (a) Structural and nonstructural vehicle tracking controls shall be implemented to minimize vehicle tracking of sediment from disturbed areas and may include tracking pads, minimizing site access, wash racks, graveled parking areas, maintaining vehicle traffic to paved areas, street sweeping and sediment control measures.
- (b) Stormwater runoff from all disturbed areas and soil storage areas must utilize or flow to one or more control measures to minimize erosion or sediment in the discharge. The control measure(s) must be selected, designed, installed and adequately sized in accordance with good engineering, hydrologic and pollution control practices for the intended application. The control measure(s) must contain or filter flows in order to prevent the [bypass](#) of flows without treatment and must be appropriate for stormwater runoff from disturbed areas and for the expected flow rate, duration, and flow conditions (e.g. sheet or concentrated flow).
- (c) Selection of control measures should prioritize the use of structural and nonstructural control measures that minimize the potential for erosion (i.e. covering materials). Selection should also prioritize phasing construction activities to minimize the amount of soil disturbance at any point in time throughout the duration of construction.
- (d) Outlets that withdraw water from or near the surface shall be installed when discharging from basins and impoundments, unless [infeasible](#).
- (e) Maintain pre-existing vegetation or equivalent control measures for areas within 50 horizontal feet of receiving waters as defined by this permit, unless infeasible.

- (f) Soil compaction must be minimized for areas where infiltration control measures will occur or where [final stabilization](#) will be achieved through vegetative cover.
  - (g) Unless infeasible, topsoil shall be preserved for those areas of a site that will utilize vegetative final stabilization.
  - (h) Minimize the amount of soil exposed during construction activity, including the disturbance of [steep slopes](#).
  - (i) Diversion control measures must minimize soil transport and erosion within the entire diversion, minimize erosion during discharge, and minimize run-on into the diversion. The permittee must minimize the discharge of pollutants throughout the installation, implementation and removal of the diversion. Diversions must meet one or more of the following conditions:
    - (1) Lined or piped structures that result in no erosion in all flow conditions.
    - (2) Diversion channels, berms, and coffer dams must be lined or composed of a material that minimizes potential for soil loss in the entire wetted perimeter during anticipated flow conditions (e.g. vegetated swale, non-erosive soil substrate). The entire length of the diversion channel must be designed with all of the following considerations: maximum flow velocity for the type of material(s) exposed to the anticipated flows to ensure that the calculated maximum shear stress of flows in the channel is not expected to result in physical damage to the channel or liner and result in discharge of pollutants. Additionally, the conditions relied on to minimize soil loss must be maintained for the projected life of the diversion (i.e. a vegetated swale must be limited to a period of time that ensures vegetative growth, minimizes erosion and maintains stable conditions).
    - (3) An alternative diversion criteria, approved by the division prior to implementation. The diversion method must be designed to minimize the discharge of pollutants and to prevent the potential for pollution or degradation to state waters as a result of the diverted flow through the diversion structure. In addition, the alternative diversion method must minimize the discharge of pollutants throughout the installation, implementation and removal of the diversion.
- ii. Practices for Other Common Pollutants
- (a) Bulk storage, individual containers of 55 gallons or greater, for petroleum products and other liquid chemicals must have secondary containment, or equivalent protection, in order to contain [spills](#) and to prevent spilled material from entering state waters.
  - (b) Control measures designed for concrete washout waste must be implemented. This includes washout waste discharged to the ground as authorized under this permit and washout waste from concrete trucks and masonry operations contained on site. The permittee must ensure the washing activities do not contribute pollutants to stormwater runoff, or receiving waters in accordance [Part I.A.1.b.ii](#). Discharges that may reach groundwater must flow through soil that has buffering capacity prior to reaching groundwater, as necessary to meet the effluent limits in this permit, including [Part I.B.3.a](#). The concrete washout location must not be located in an area where shallow groundwater may be present and would result in buffering capacity not being adequate, such as near natural drainages, springs, or wetlands. This permit authorizes discharges to the ground of concrete washout waste, but does not authorize on-site waste disposal per [Part I.B.3.d](#).
  - (c) In the event that water remains onsite and contains pollutants either from the

firefighting activities or picked up from the site (i.e. in a gutter, sediment basin, etc.) after active emergency response is complete, the permittee must ensure the remaining water containing pollutants is properly removed and disposed of in order to minimize pollutants from discharging from the site, unless infeasible.

iii. Stabilization Requirements

The following requirements must be implemented for each site.

- (a) Temporary stabilization must be implemented for earth disturbing activities on any portion of the site where ground disturbing construction activity has permanently ceased, or temporarily ceased for more than 14 calendar days. Temporary stabilization methods may include, but are not limited to, tarps, soil tackifier, and hydroseed. The permittee may exceed the 14-day schedule when either the function of the specific area of the site requires it to remain disturbed or physical characteristics of the terrain and climate prevent stabilization. The SWMP must document the constraints necessitating the alternative schedule, provide the alternate stabilization schedule, and identify all locations where the alternative schedule is applicable on the site map. Minimum inspection frequency and scope, as directed in Part I.D., must be followed for temporarily stabilized areas.
- (b) Final stabilization must be implemented for all construction sites covered under this permit. Final stabilization is reached when (1), (2), and (3) below are complete:
  - (1) All construction activities are complete.
  - (2) Permanent stabilization methods are complete. Permanent stabilization methods include, but are not limited to, permanent pavement or concrete, hardscape, xeriscape, stabilized driving surfaces, vegetative cover, or equivalent permanent alternative stabilization methods. The division may approve alternative final stabilization criteria for specific operations. Vegetative cover must meet the following criteria:
    - a. Evenly distributed perennial vegetation, and
    - b. Coverage, at a minimum, equal to 70 percent of what would have been provided by native vegetation in a local, undisturbed area or adequate reference site, and
  - (3) The permittee must ensure all temporary control measures are removed from the construction site once final stabilization is achieved, except when the control measure specifications allow the control measure to be left in place (i.e. bio-degradable control measures).
- (c) Final stabilization must be designed and installed as a permanent feature. Final stabilization measures for obtaining a vegetative cover or alternative stabilization methods include, but are not limited to, the following as appropriate:
  - (1) Seed mix selection and application methods;
  - (2) Soil preparation and amendments;
  - (3) Soil stabilization methods to provide adequate protection to minimize erosion (e.g. crimped straw, hydro mulch or rolled erosion control products);
  - (4) Appropriate sediment control measures as needed until final stabilization is achieved;

(5) Permanent pavement, hardscape, xeriscape, stabilized driving surfaces;

(d) Other alternative stabilization practices as applicable.

b. Maintenance

The permittee must ensure that all control measures remain in effective operating condition and are protected from activities that would reduce their effectiveness. Control measures must be maintained in accordance with good engineering, hydrologic and pollution control practices. Observations leading to the required maintenance of control measures can be made during a site inspection, or during general observations of site conditions. The necessary repairs or modifications to a [control measure requiring routine maintenance](#), as defined in Part I.E., must be conducted to maintain an effective operating condition. This section is not subject to the requirements in [Part I.B.1.c](#) below.

c. Corrective Actions

The permittee must assess the adequacy of control measures at the site, and the need for changes to those control measures, to ensure continued effective performance.

When an [inadequate control measure](#), as defined in Part I.E., is identified (i.e., new or replacement control measures become necessary), the following corrective action requirements apply. The permittee is in noncompliance with the permit until the inadequate control measure is replaced or corrected and returned to effective operating condition in compliance with [Part I.B.1](#) and the general requirements in [Part I.B.3](#). If the inadequate control measure results in noncompliance that meets the conditions of Part II.L., the permittee must also meet the requirements of that section.

i. The permittee must take all necessary steps to minimize or prevent the discharge of pollutants from the permitted area and manage any stormwater run-on onto the site until a control measure is implemented and made operational and/or an inadequate control measure is replaced or corrected and returned to effective operating condition. If it is infeasible to install or repair the control measure immediately after discovering the deficiency, the following must be documented in the SWMP in [Part I.D.5.c](#) and kept on record in accordance with the recordkeeping requirements in Part II.

(a) Describe why it is infeasible to initiate the installation or repair immediately; and

(b) Provide a schedule for installing or repairing the control measure and returning it to an effective operating condition as soon as possible.

ii. If applicable, the permittee must remove and properly dispose of any unauthorized release or discharge within and from the permitted area (e.g., discharge of non-stormwater, untreated stormwater containing pollutants, spill, or leak not authorized by this permit.) The permittee must also clean up any contaminated surfaces, if feasible, to minimize discharges of the material in subsequent storm events, including water remaining from the response that contains pollutants after active emergency firefighting response is complete.

2. Discharges to an Impaired Waterbody

a. [Total Maximum Daily Load](#) (TMDL)

If the discharge from the site of permit coverage flows to or could reasonably be expected to flow to any water body for which a TMDL has been approved, and stormwater discharges associated with construction activity were assigned a pollutant-specific Wasteload Allocation (WLA) under the TMDL, the division may:

i. Ensure the WLA is implemented properly through alternative local requirements, such as by a

municipal stormwater permit; or

- ii. Notify the permittee of the WLA and amend the permittee's certification to add specific effluent limits and other requirements, as appropriate. The permittee may be required to do the following:
  - (a) Under the permittee's SWMP, implement specific control measures based on requirements of the WLA, and evaluate whether the requirements are met through implementation of existing stormwater control measures or if additional control measures are necessary. Document the calculations or other evidence demonstrating that the requirements are expected to be met; and
  - (b) If the evaluation shows that additional or modified control measures are necessary, describe the type and schedule for the control measure additions or modifications.
- iii. Discharge monitoring may also be required. The permittee may maintain coverage under the general permit provided they comply with the applicable requirements outlined above. The division reserves the right to require individual or alternate general permit coverage.

### 3. General Requirements

- a. Discharges authorized by this permit shall not cause, have the reasonable potential to cause, or measurably contribute to an exceedance of any applicable water quality standard, including narrative standards for water quality.
- b. The division may require sampling and testing, on a case-by-case basis, in the event that there is reason to suspect that the SWMP is not adequately minimizing pollutants in stormwater or in order to measure the effectiveness of the control measures in removing pollutants in the effluent. Such monitoring may include Whole Effluent Toxicity testing.
- c. The permittee must comply with the lawful requirements of federal agencies, municipalities, counties, drainage districts and other local agencies including applicable requirements in [Municipal Stormwater Management Programs](#) developed to comply with CDPS permits. The permittee must comply with local stormwater management requirements, policies and guidelines including those for erosion and sediment control.
- d. All construction site wastes must be properly managed to prevent potential pollution of state waters. This permit does not authorize on-site waste disposal.
- e. This permit does not relieve the permittee of the reporting requirements in 40 CFR 110, 40 CFR 117 or 40 CFR 302. Any discharge of hazardous material must be handled in accordance with the division's Noncompliance Notification Requirements (see [Part II.L](#) of the permit).

## C. STORMWATER MANAGEMENT PLAN (SWMP) REQUIREMENTS

### 1. SWMP General Requirements

- a. A SWMP shall be developed for each construction site listed under [Part I.A.3.a](#), including but not limited to, construction activity that will disturb one acre or more and/or are part of a common plan of development or sale covered by this permit. The SWMP must be prepared in accordance with good engineering, hydrologic and pollution control practices.
  - i. For public emergency related sites, a SWMP shall be created no later than 14 days after the commencement of construction activities.
- b. The permittee must implement the provisions of the SWMP as written and updated, from commencement of construction activity until final stabilization is complete. The division may review the SWMP.

- c. A copy of the SWMP must be retained onsite or be onsite when construction activities are occurring at the site unless the permittee specifies another location and obtains approval from the division.

## 2. SWMP Content

- a. The SWMP, at a minimum, must include the following elements.
  - i. Qualified Stormwater Manager. The SWMP must list individual(s) by title and name who are designated as responsible for implementing the SWMP in its entirety and meet the definition of a Qualified Stormwater Manager. This role may be filled by more than one individual.
  - ii. Spill Prevention and Response Plan. The SWMP must have a spill prevention and response plan. The plan may incorporate by reference any part of a Spill Prevention Control and Countermeasure (SPCC) plan under section 311 of the Clean Water Act (CWA) or a Spill Prevention Plan required by a separate CDPS permit. The relevant sections of any referenced plans must be available as part of the SWMP consistent with Part I.C.4.
  - iii. Other CDPS Permits. The SWMP must list the applicable CDPS permits associated with the permitted site and the activities occurring on the permitted site (e.g. a CDPS Dewatering Permit).
  - iv. Materials Handling. The SWMP must describe handling procedures of all control measures implemented at the site to minimize impacts from handling significant materials that could contribute pollutants to runoff. These handling procedures can include control measures for pollutants and activities such as, exposed storage of building materials, paints and solvents, landscape materials, fertilizers or chemicals, sanitary waste material, trash and equipment maintenance or fueling procedures.
  - v. Potential Sources of Pollution. The SWMP must list all potential sources of pollution which may reasonably be expected to affect the quality of stormwater discharges associated with construction activity from the site. This may include, but is not limited to, the following pollutant sources:
    - (a) Disturbed and stored soils;
    - (b) Vehicle tracking of sediments;
    - (c) Management of contaminated soils, if known to be present, or if contaminated soils are found during construction;
    - (d) Loading and unloading operations;
    - (e) Outdoor storage activities (erodible building materials, fertilizers, chemicals, etc.);
    - (f) Vehicle and equipment maintenance and fueling;
    - (g) Significant dust or particulate generating processes (e.g., saw cutting material, including dust);
    - (h) Routine maintenance activities involving fertilizers, pesticides, herbicides, detergents, fuels, solvents, oils, etc.;
    - (i) On-site waste management practices (waste piles, liquid wastes, dumpsters);
    - (j) Concrete truck/equipment washing, including washing of the concrete truck chute and associated fixtures and equipment;
    - (k) Dedicated asphalt, concrete batch plants and masonry mixing stations;

(l) Non-industrial waste sources such as worker trash and portable toilets.

- vi. Implementation of Control Measures. The SWMP must include design specifications that contain information on the implementation of all the structural and nonstructural control measures in use on the site in accordance with good engineering, hydrologic and pollution control practices; including, as applicable, drawings, dimensions, installation information, materials, implementation processes, control measure-specific inspection expectations, and maintenance requirements.

The SWMP must include a documented use agreement between the permittee and the owner or operator of any control measures located outside of the permitted area, that are utilized by the permittee's construction site for compliance with this permit, but not under the direct control of the permittee. The permittee is responsible for ensuring that all control measures located outside of their permitted area, that are being utilized by the permittee's construction site, are properly maintained and in compliance with all terms and conditions of the permit. The SWMP must include all information required of and relevant to any such control measures located outside the permitted area, including location, installation specifications, design specifications and maintenance requirements.

- vii. Site Description. The SWMP must include a site description which includes, at a minimum, the following:
- (a) The nature of the construction activity at the site;
  - (b) The proposed schedule for the sequence for major construction activities and the planned implementation of control measures for each phase. (e.g. clearing, grading, utilities, vertical, etc.);
  - (c) Estimates of the total acreage of the site, and the acreage expected to be disturbed by clearing, excavation, grading, or any other construction activities;
  - (d) A summary of any existing data and sources used in the development of the construction site plans or SWMP that describe the soil types found in the permitted area and the erodibility of the identified soil types;
  - (e) A description of the percent cover of native vegetation on the site if the site is undisturbed, or the percent cover of native vegetation in a similar, local undisturbed area or adequate reference area if the site is disturbed. Include the source or methodology for determining the percentage. If a percent cover is not appropriate for the site location (i.e. arid), describe the technique and justification for the identified cover of native vegetation;
  - (f) A description of any allowable non-stormwater discharges at the site, including those being discharged under a separate CDPS permit or a division low risk discharge guidance policy, and applicable control measures installed;
  - (g) A description of the drainage patterns from the site, including a description of the immediate source receiving the discharge and the receiving water(s) of the discharge, if different than the immediate source. If the stormwater discharge is to a [municipal separate storm sewer system](#), include the name of the entity owning that system, the location(s) of the stormwater discharge, and the receiving water(s);
  - (h) A description of all stream crossings located within the construction site boundary; and
  - (i) A description of the alternate temporary stabilization schedule, if applicable ([Part I.B.1.a.iii\(a\)](#)).



- (j) A description of the alternative diversion criteria as approved by the division, if applicable ([Part I.B.1.a.i\(i\)\(3\)](#)).

viii. Site Map. The SWMP must include a site map which includes, at a minimum, the following:

- (a) Construction site boundaries;
- (b) Flow arrows that depict stormwater flow directions on-site and runoff direction;
- (c) All areas of ground disturbance including areas of borrow and fill;
- (d) Areas used for storage of soil;
- (e) Locations of all waste accumulation areas, including areas for liquid, concrete, masonry, and asphalt;
- (f) Locations of dedicated asphalt, concrete batch plants and masonry mixing stations;
- (g) Locations of all structural control measures;
- (h) Locations of all non-structural control measures (e.g. temporary stabilization);
- (i) Locations of springs, streams, wetlands, diversions and other state waters, including areas that require pre-existing vegetation be maintained within 50 feet of a receiving water, where determined feasible in accordance with [Part I.B.1.a.i\(e\)](#);
- (j) Locations of all stream crossings located within the construction site boundary; and
- (k) Locations where alternative temporary stabilization schedules apply.

ix. Temporary Stabilization, Final Stabilization and Long Term Stormwater Management.

- (a) The SWMP must document the constraints necessitating an alternative temporary stabilization schedule, as referenced in [Part I.B.1.a.iii\(a\)](#), provide the alternate stabilization schedule, and identify all locations where the alternative schedule is applicable on the site map.
- (b) The SWMP must describe and locate the methods used to achieve final stabilization of all disturbed areas at the site, as listed in [Part I.B.1.a.iii\(b\)](#).
- (c) The SWMP must describe the measures used to establish final stabilization through vegetative cover or alternative stabilization method, as referenced in [Part I.B.1.a.iii\(c\)](#), and describe and locate any temporary control measures in place during the process of final stabilization.
- (d) The SWMP must describe and locate any planned permanent control measures to control pollutants in stormwater discharges that will occur after construction operations are completed, including but not limited to, detention/retention ponds, rain gardens, stormwater vaults, etc.

x. Inspection Reports. The SWMP must include documented inspection reports in accordance with [Part I.D.5.c](#).

### 3. SWMP Review and Revisions

Permittees must keep a record of SWMP changes made that includes the date and identification of the changes. The SWMP must be amended when the following occurs:

- a. A change in design, construction, operation, or maintenance of the site requiring implementation



of new or revised control measures;

- b. The SWMP proves ineffective in controlling pollutants in stormwater runoff in compliance with the permit conditions;
- c. Control measures identified in the SWMP are no longer necessary and are removed; and
- d. Corrective actions are taken onsite that result in a change to the SWMP.
- e. The site or areas of the site qualifying for reduced frequency inspections under [Part I.D.4](#).

For SWMP revisions made prior to or following a change(s) onsite, including revisions to sections addressing site conditions and control measures, a notation must be included in the SWMP that identifies the date of the site change, the control measure removed, or modified, the location(s) of those control measures, and any changes to the control measure(s). The permittee must ensure the site changes are reflected in the SWMP. The permittee is noncompliant with the permit until the SWMP revisions have been made.

#### 4. SWMP Availability

A copy of the SWMP must be provided upon request to the division, EPA, and any local agency with authority for approving sediment and erosion plans, grading plans or stormwater management plans within the time frame specified in the request. If the SWMP is required to be submitted to any of these entities, the submission must include a signed certification in accordance with [Part I.A.3.e](#), certifying that the SWMP is complete and compliant with all terms and conditions of the permit.

All SWMPs required under this permit are considered reports that must be available to the public under Section 308(b) of the CWA and Section 61.5(4) of the CDPS regulations. The permittee must make plans available to members of the public upon request. However, the permittee may claim any portion of a SWMP as confidential in accordance with 40 CFR Part 2.

### D. SITE INSPECTIONS

Site inspections must be conducted in accordance with the following requirements. The required inspection schedules are a minimum frequency and do not affect the permittee's responsibility to implement control measures in effective operating condition as prescribed in the SWMP, [Part I.C.2.a.vi](#), as proper maintenance of control measures may require more frequent inspections. Site inspections shall start within 7 calendar days of the commencement of construction activities on site.

#### 1. Person Responsible for Conducting Inspections

The person(s) inspecting the site may be on the permittee's staff or a third party hired to conduct stormwater inspections under the direction of the permittee(s). The permittee is responsible for ensuring that the inspector meets the definition of a Qualified Stormwater Manager. The inspector may be different than the individual(s) listed in [Part I.C.2.a.i](#).

#### 2. Inspection Frequency

Permittees must conduct site inspections in accordance with on the following minimum frequencies, unless the site meets the requirements of [Part I.D.3](#). All inspections must be recorded per [Part I.D.5.c](#).

- a. At least one inspection every 7 calendar days; or
- b. At least one inspection every 14 calendar days, if post-storm event inspections are conducted within 24 hours after the end of any precipitation or snowmelt event that causes surface erosion. Post-storm inspections may be used to fulfill the 14-day routine inspection requirement.
- c. When site conditions make the schedule required in this section impractical, the permittee may

petition the division to grant an alternate inspection schedule. The alternative inspection schedule must not be implemented prior to written approval by the division and incorporation into the SWMP.

### 3. Inspection Frequency for Discharges to Outstanding Waters

Permittees must conduct site inspections at least once every 7 calendar days for sites that discharge to a water body designated as an Outstanding Water by the Water Quality Control Commission.

### 4. Reduced Inspection Frequency

The permittee may perform site inspections at the following reduced frequencies when one of the following conditions exists:

#### a. Post-Storm Inspections at Temporarily Idle Sites

For permittees choosing an inspection frequency pursuant to [Part I.D.2.b](#) and if no construction activities will occur following a storm event, post-storm event inspections must be conducted prior to re-commencing construction activities, and no later than 72 hours following the storm event. If the post-storm event inspection qualifies under this section, the inspection delay must be documented in the inspection record per [Part I.D.5.c](#). Routine inspections must still be conducted at least every 14 calendar days.

#### b. Inspections at Completed Sites/Areas

When the site, or portions of a site, are awaiting establishment of a vegetative ground cover and final stabilization, the permittee must conduct a thorough inspection of the stormwater management system at least once every 30 days. Post-storm event inspections are not required under this schedule. This reduced inspection schedule is allowed if all of the following criteria are met:

- i. All construction activities resulting in ground disturbance are complete;
- ii. All activities required for final stabilization, in accordance with [Part I.B.1.a.iii\(b\) & \(c\)](#) and with the SWMP, have been completed, with the exception of the application of seed that has not occurred due to seasonal conditions or the necessity for additional seed application to augment previous efforts; and
- iii. The SWMP has been amended to locate those areas to be inspected in accordance with the reduced schedule allowed for in this paragraph.

#### c. Winter Conditions Inspections Exclusion

Inspections are not required for sites that meet all of the following conditions: construction activities are temporarily halted, snow cover exists over the entire site for an extended period, and melting conditions posing a risk of surface erosion do not exist. This inspection exception is applicable only during the period where melting conditions do not exist, and applies to the routine 7-day, 14-day and monthly inspections, as well as the post-storm-event inspections. When this inspection exclusion is implemented, the following information must be documented in accordance with the requirements in [Part I.C.3](#) and [Part I.D.5.c](#):

- i. Dates when snow cover existed;
- ii. Date when construction activities ceased; and
- iii. Date melting conditions began.

### 5. Inspection Scope

a. Areas to Be Inspected

When conducting a site inspection the following areas, if applicable, must be inspected for evidence of, or the potential for, pollutants leaving the construction site boundaries, entering the stormwater drainage system or discharging to state waters:

- i. Construction site perimeter;
- ii. All disturbed areas;
- iii. Locations of installed control measures;
- iv. Designated haul routes;
- v. Material and waste storage areas exposed to precipitation;
- vi. Locations where stormwater has the potential to discharge offsite; and
- vii. Locations where vehicles exit the site.

b. Inspection Requirements

- i. Visually verify whether all implemented control measures are in effective operational condition and are working as designed in their specifications to minimize pollutant discharges.
- ii. Determine if there are new potential sources of pollutants.
- iii. Assess the adequacy of control measures at the site to identify areas requiring new or modified control measures to minimize pollutant discharges.
- iv. Identify all areas of non-compliance with the permit requirements and, if necessary, implement corrective action(s) in accordance with [Part I.B.1.c](#).

c. Inspection Reports

The permittee must keep a record of all inspections conducted for each permitted site. Inspection reports must identify any incidents of noncompliance with the terms and conditions of this permit. All inspection reports must be signed and dated in accordance with [Part I.A.3.f](#). Inspection records must be retained in accordance with [Part II.O](#). At a minimum, the inspection report must include:

- i. The inspection date;
- ii. Name(s) and title(s) of personnel conducting the inspection;
- iii. Weather conditions at the time of inspection;
- iv. Phase of construction at the time of inspection;
- v. Estimated acreage of disturbance at the time of inspection;
- vi. Location(s) and identification of control measures requiring routine maintenance;
- vii. Location(s) and identification of discharges of sediment or other pollutants from the site;
- viii. Location(s) and identification of inadequate control measures;
- ix. Location(s) and identification of additional control measures needed that were not in place at the time of inspection;

- x. Description of corrective action(s) for items vii, viii, ix, above, dates corrective action(s) were completed, including requisite changes to the SWMP, as necessary;
- xi. Description of the minimum inspection frequency (either in accordance with [Part I.D.2](#), [Part I.D.3](#) or [Part I.D.4.](#)) utilized when conducting each inspection.
- xii. Deviations from the minimum inspection schedule as required in [Part I.D.2](#). This would include documentation of division approval for an alternate inspection schedule outlined in [Part I.D.2.c](#);
- xiii. After adequate corrective action(s) have been taken, or where a report does not identify any incidents requiring corrective action, the report shall contain a statement as required in [Part I.A.3.f](#).

## E. DEFINITIONS

For the purposes of this permit:

- (1) Bypass the intentional diversion of waste streams from any portion of a treatment facility in accordance with 40 CFR 122.41(m)(1)(i) and Regulation 61.2(12).
- (2) Common Plan of Development or Sale - A contiguous area where multiple separate and distinct construction activities may be taking place at different times on different schedules, but remain related. The division has determined that “contiguous” means construction activities located in close proximity to each other (within ¼ mile). Construction activities are considered to be “related” if they share the same development plan, builder or contractor, equipment, storage areas, etc. “Common plan of development or sale” includes construction activities that are associated with the construction of field wide oil and gas permits for facilities that are related.
- (3) Construction Activity - Ground surface disturbing and associated activities (land disturbance), which include, but are not limited to, clearing, grading, excavation, demolition, installation of new or improved haul roads and access roads, staging areas, stockpiling of fill materials, and borrow areas. Construction does not include routine maintenance to maintain the original line and grade, hydraulic capacity, or original purpose of the facility. Activities to conduct repairs that are not part of routine maintenance or for replacement are construction activities and are not routine maintenance. Repaving activities where underlying and/or surrounding soil is exposed as part of the repaving operation are considered construction activities. Construction activity is from initial ground breaking to final stabilization regardless of ownership of the construction activities.
- (4) Control Measure - Any best management practice or other method used to prevent or reduce the discharge of pollutants to state waters. Control measures include, but are not limited to, best management practices. Control measures can include other methods such as the installation, operation, and maintenance of structural controls and treatment devices.
- (5) Control Measure Requiring Routine Maintenance - Any control measure that is still operating in accordance with its design and the requirements of this permit, but requires maintenance to prevent a breach of the control measure. See also inadequate control measure.
- (6) Dedicated Asphalt, Concrete Batch Plants and Masonry Mixing Stations - Are batch plants or mixing stations located on, or within ¼ mile of, a construction site and that provide materials only to that specific construction site.
- (7) Diversion - Discharges of state waters that are temporarily routed through channels or structures (e.g. in-stream, uncontaminated springs, non-pumped groundwater, temporary rerouting of surface waters).
- (8) Final Stabilization - The condition reached when construction activities at the site have been

- completed, permanent stabilization methods are complete, and temporary control measures are removed. Areas being stabilized with a vegetative cover must have evenly distributed perennial vegetation. The vegetation coverage must be, at a minimum, equal to 70 percent of what would have been provided by native vegetation in a local, undisturbed area or adequate reference site.
- (9) Good Engineering, Hydrologic and Pollution Control Practices: are methods, procedures, and practices that:
- a. Are based on basic scientific fact(s).
  - b. Reflect best industry practices and standards.
  - c. Are appropriate for the conditions and pollutant sources.
  - d. Provide appropriate solutions to meet the associated permit requirements, including practice based effluent limits.
- (10) Inadequate Control Measure - Any control measure that is not designed or implemented in accordance with the requirements of the permit and/or any control measure that is not implemented to operate in accordance with its design. See also Control Measure Requiring Routine Maintenance.
- (11) Infeasible - Not technologically possible, or not economically practicable and achievable in light of best industry practices.
- (12) Minimize - reduce or eliminate to the extent achievable using control measures that are technologically available and economically practicable and achievable in light of best industry practice.
- (13) Municipality - A city, town, county, district, association, or other public body created by, or under, State law and having jurisdiction over disposal of sewage, industrial wastes, or other wastes, or a designated and approved management agency under section 208 of CWA (1987).
- (14) Municipal Separate Storm Sewer System (MS4) - A conveyance or system of conveyances (including roads with drainage systems, municipal streets, catch basins, curbs, gutters, ditches, man-made channels, or storm drains):
- a. Owned or operated by a State, city, town, county, district, association, or other public body (created by or pursuant to State law) having jurisdiction over disposal of sewage, industrial wastes, stormwater, or other wastes, including special districts under State law such as a sewer district, flood control district or drainage district, or similar entity, or a designated and approved management agency under section 208 of the CWA that discharges to state waters;
    - i. Designed or used for collecting or conveying stormwater;
    - ii. Are not a combined sewer; and
    - iii. Are not part of a Publicly Owned Treatment Works (POTW). See 5 CCR 1002-61.2(62).
- (15) Municipal Stormwater Management Program - A stormwater program operated by a municipality, typically to meet the requirements of the municipalities MS4 discharge certification.
- (16) Operator - The party that has operational control over day-to-day activities at a project site which are necessary to ensure compliance with the permit. This party is authorized to direct individuals at a site to carry out activities required by the permit (i.e. the general contractor).

- (17) Outstanding Waters - Waters designated as outstanding waters pursuant to Regulation 31, Section 31.8(2)(a). The highest level of water quality protection applies to certain waters that constitute an outstanding state or national resource.
- (18) Owner - The party that has overall control of the activities and that has funded the implementation of the construction plans and specifications. This is the party that may have ownership of, a long term lease of, or easements on the property on which the construction activity is occurring (e.g. the developer).
- (19) Permittee(s) - The owner and operator named in the discharge certification issued under this permit for the construction site specified in the certification.
- (20) Point Source - Any discernible, confined, and discrete conveyance, including, but not limited to, any pipe, ditch, channel, tunnel, conduit, well, discrete fissure, container, rolling stock, concentrated animal feeding operation, or vessel or other floating craft, from which pollutants are or may be discharged. Point source does not include irrigation return flow. See 5 CCR 102-61.2(75).
- (21) Pollutant - Dredged spoil, dirt, slurry, solid waste, incinerator residue, sewage, sewage sludge, garbage, trash, chemical waste, biological nutrient, biological material, radioactive material, heat, wrecked or discarded equipment, rock, sand, or any industrial, municipal or agricultural waste. See 5 CCR 1002-61.2(76).
- (22) Presentation of credentials - a government issued form of identification, if in person; or (ii) providing name, position and purpose of inspection if request to enter is made via telephone, email or other form of electronic communication. A Permittee's non-response to a request to enter upon presentation of credentials constitutes a denial to such request, and may result in violation of the Permit.
- (23) Process Water - Any water which, during manufacturing or processing, comes into contact with or results from the production of any raw material, intermediate product, finished product, by product or waste product.
- (24) Public Emergency Related Site - a project initiated in response to an unanticipated emergency (e.g., mud slides, earthquake, extreme flooding conditions, disruption in essential public services), for which the related work requires immediate authorization to avoid imminent endangerment to human health or the environment, or to reestablish essential public services.
- (25) Qualified Stormwater Manager - An individual knowledgeable in the principles and practices of erosion and sediment control and pollution prevention, and with the skills to assess conditions at construction sites that could impact stormwater quality and to assess the effectiveness of stormwater controls implemented to meet the requirements of this permit.
- (26) Qualifying Local Program - A municipal program for stormwater discharges associated with small construction activity that was formally approved by the division as a qualifying local program.
- (27) Receiving Water - Any classified or unclassified surface water segment (including tributaries) in the State of Colorado into which stormwater associated with construction activities discharges. This definition includes all water courses, even if they are usually dry, such as borrow ditches, arroyos, and other unnamed waterways.
- (28) Severe Property Damage - substantial physical damage to property, damage to the treatment facilities which causes them to become inoperable, or substantial and permanent loss of natural resources which can reasonably be expected to occur in the absence of a bypass. Severe property damage does not mean economic loss caused by delays in production. See 40 CFR 122.41(m)(1)(ii).
- (29) Significant Materials - Include, but not limited to, raw materials; fuels; materials such as solvents, detergents, and plastic pellets; finished materials such as metallic products; raw materials used in

- food processing or production; hazardous substances designated under section 101(14) of CERCLA; any chemical the permittee is required to report under section 313 of Title III of the Superfund Amendments and Reauthorization Act (SARA); fertilizers; pesticides; and waste products such as ashes, slag and sludge that have the potential to be released with stormwater discharges.
- (30) Small Construction Activity - The discharge of stormwater from construction activities that result in land disturbance of equal to, or greater than, one acre and less than five acres. Small construction activity also includes the disturbance of less than one acre of total land area that is part of a larger common plan of development or sale, if the larger common plan ultimately disturbs equal to, or greater than, one acre and less than five acres.
- (31) Spill - An unintentional release of solid or liquid material which may pollute state waters.
- (32) State Waters - means any and all surface and subsurface waters which are contained in or flow in or through this state, but does not include waters in sewage systems, waters in treatment works of disposal systems, waters in potable water distribution systems, and all water withdrawn for use until use and treatment have been completed.
- (33) Steep Slopes: where a local government, or industry technical manual (e.g. stormwater BMP manual) has defined what is to be considered a “steep slope”, this permit’s definition automatically adopts that definition. Where no such definition exists, steep slopes are automatically defined as those that are 3:1 or greater.
- (34) Stormwater - Precipitation runoff, snow melt runoff, and surface runoff and drainage. See 5 CCR 1002-61.2(103).
- (35) Total Maximum Daily Loads (TMDLs) -The sum of the individual wasteload allocations (WLA) for point sources and load allocations (LA) for nonpoint sources and natural background. For the purposes of this permit, a TMDL is a calculation of the maximum amount of a pollutant that a waterbody can receive and still meet water quality standards, and an allocation of that amount to the pollutant’s sources. A TMDL includes WLAs, LAs, and must include a margin of safety (MOS), and account for seasonal variations. See section 303(d) of the CWA and 40 C.F.R. 130.2 and 130.7.
- (36) Upset - an exceptional incident in which there is unintentional and temporary noncompliance with permit effluent limitations because of factors beyond the reasonable control of the permittee. An upset does not include noncompliance to the extent caused by operational error, improperly designed treatment facilities, inadequate treatment facilities, lack of preventative maintenance, or careless or improper operation in accordance with 40 CFR 122.41(n) and Regulation 61.2(114).

#### F. MONITORING

The division may require sampling and testing, on a case-by-case basis. If the division requires sampling and testing, the division will send a notification to the permittee. Reporting procedures for any monitoring data collected will be included in the notification.

If monitoring is required, the following applies:

1. The thirty (30) day average must be determined by the arithmetic mean of all samples collected during a thirty (30) consecutive-day period; and
2. A grab sample, for monitoring requirements, is a single “dip and take” sample.

#### G. OIL AND GAS CONSTRUCTION

Stormwater discharges associated with construction activities directly related to oil and gas exploration, production, processing, and treatment operations or transmission facilities are regulated under the Colorado Discharge Permit System Regulations (5 CCR 1002-61), and require coverage under this permit in accordance with that regulation. However, references in this permit to specific authority under the CWA do not apply to

stormwater discharges associated with these oil and gas related construction activities, to the extent that the references are limited by the federal Energy Policy Act of 2005.



## Part II: Standard Permit Conditions

### A. DUTY TO COMPLY

The permittee must comply with all conditions of this permit. Any permit noncompliance constitutes a violation of the Water Quality Control Act and is grounds for:

1. Enforcement action;
2. Permit termination, revocation and reissuance, or modification; or
3. Denial of a permit renewal application.

### B. DUTY TO REAPPLY

If the permittee wishes to continue an activity regulated by this permit after the expiration date of this permit, the permittee must apply for and obtain authorization as required by Part I.A.3.k. of the permit.

### C. NEED TO HALT OR REDUCE ACTIVITY NOT A DEFENSE

It shall not be a defense for a permittee in an enforcement action that it would have been necessary to halt or reduce the permitted activity in order to maintain compliance with the conditions of this permit.

### D. DUTY TO MITIGATE

A permittee must take all reasonable steps to minimize or prevent any discharge in violation of this permit which has a reasonable likelihood of adversely affecting human health or the environment.

### E. PROPER OPERATION AND MAINTENANCE

A permittee must at all times properly operate and maintain all facilities and systems of treatment and control (and related appurtenances) that are installed or used by the permittee to achieve compliance with the conditions of this permit. Proper operation and maintenance also includes adequate laboratory controls and appropriate quality assurance procedures. This provision requires the operation of backup or auxiliary facilities or similar systems which are installed by the permittee only when the operation is necessary to achieve compliance with the conditions of this permit. This requirement can be met by meeting the requirements for Part I.B., I.C., and I.D. above. See also 40 C.F.R. § 122.41(e).

### F. PERMIT ACTIONS

This permit may be modified, revoked and reissued, or terminated for cause. The permittee request for a permit modification, revocation and reissuance, or termination, or a notification of planned changes or anticipated noncompliance does not stay any permit condition. Any request for modification, revocation, reissuance, or termination under this permit must comply with all terms and conditions of Regulation 61.8(8).

### G. PROPERTY RIGHTS

In accordance with 40 CFR 122.41(g) and 5 CCR 1002-61, 61.8(9):

1. The issuance of a permit does not convey any property or water rights in either real or personal property, or stream flows or any exclusive privilege.
2. The issuance of a permit does not authorize any injury to person or property or any invasion of personal rights, nor does it authorize the infringement of federal, state, or local laws or regulations.
3. Except for any toxic effluent standard or prohibition imposed under Section 307 of the Federal act or any standard for sewage sludge use or disposal under Section 405(d) of the Federal act, compliance with a permit during its term constitutes compliance, for purposes of enforcement, with Sections 301,

302, 306, 318, 403, and 405(a) and (b) of the Federal act. However, a permit may be modified, revoked and reissued, or terminated during its term for cause as set forth in Section 61.8(8) of the Colorado Discharge Permit System Regulations.

#### H. DUTY TO PROVIDE INFORMATION

The permittee shall furnish to the division, within a reasonable time, any information which the division may request to determine whether cause exists for modifying, revoking and reissuing, or terminating this permit, or to determine compliance with this permit. The permittee shall also furnish to the division, upon request, copies of records required to be kept by this permit in accordance with 40 CFR 122.41(h) and/or Regulation 61.8(3)(q).

#### I. INSPECTION AND ENTRY

The permittee shall allow the division and the authorized representative, upon the [presentation of credentials](#) as required by law, to allow for inspections to be conducted in accordance with 40 CFR 122.41(i), Regulation 61.8(3), and Regulation 61.8(4):

1. To enter upon the permittee's premises where a regulated facility or activity is located or in which any records are required to be kept under the terms and conditions of this permit;
2. At reasonable times to have access to and copy any records required to be kept under the terms and conditions of this permit;
3. At reasonable times, inspect any monitoring equipment or monitoring method required in the permit; and
4. To enter upon the permittee's premises in a reasonable manner and at a reasonable time to inspect or investigate, any actual, suspected, or potential source of water pollution, or any violation of the Colorado Water Quality Control Act. The investigation may include: sampling of any discharges, stormwater or [process water](#), taking of photographs, interviewing site staff on alleged violations and other matters related to the permit, and assessing any and all facilities or areas within the site that may affect discharges, the permit, or an alleged violation.

The permittee shall provide access to the division or other authorized representatives upon presentation of proper credentials. A permittee's non-response to a request to enter upon presentation of credentials constitutes a denial of such request, and may result in a violation of the permit.

#### J. MONITORING AND RECORDS

1. Samples and measurements taken for the purpose of monitoring must be representative of the volume and nature of the monitored activity.
2. The permittee must retain records of all monitoring information, including all calibration and maintenance records and all original strip chart recordings for continuous monitoring instrumentation, copies of all reports required by this permit, and records of all data used to complete the application for this permit, for a period of at least three years from the date the permit expires or the date the permittee's authorization is terminated. This period may be extended by request of the division at any time.
3. Records of monitoring information must include:
  - a. The date, exact place, and time of sampling or measurements;
  - b. The individual(s) who performed the sampling or measurements;
  - c. The date(s) analyses were performed

- d. The individual(s) who performed the analyses;
  - e. The analytical techniques or methods used; and
  - f. The results of such analyses.
4. Monitoring must be conducted according to test procedures approved under 40 CFR Part 136, unless other test procedures have been specified in the permit.

#### K. SIGNATORY REQUIREMENTS

##### 1. Authorization to Sign:

All documents required to be submitted to the division by the permit must be signed in accordance with the following criteria:

- a. For a corporation: by a responsible corporate officer. For the purpose of this subsection, a responsible corporate officer means:
  - i. A president, secretary, treasurer, or vice president of the corporation in charge of a principal business function, or any other person who performs similar policy- or decision-making functions for the corporation, or
  - ii. The manager of one or more manufacturing, production, or operating facilities, provided, the manager is authorized to make management decisions which govern the operation of the regulated facility including having the explicit or implicit duty of making major capital investment recommendations, and initiating and directing other comprehensive measures to assure long term environmental compliance with environmental laws and regulations; the manager can ensure that the necessary systems are established or actions taken to gather complete and accurate information for permit application requirements; and where authority to sign documents has been assigned or delegated to the manager in accordance with corporate procedures.
- b. For a partnership or sole proprietorship: by a general partner or the proprietor, respectively; or
- c. For a [municipality](#), state, federal, or other public agency: By either a principal executive officer or ranking elected official. For purposes of this subsection, a principal executive officer of a federal agency includes
  - i. The chief executive officer of the agency, or
  - ii. A senior executive officer having responsibility for the overall operations of a principal geographic unit of the agency. (e.g. Regional Administrator of EPA)

##### 2. Electronic Signatures

For persons signing applications for coverage under this permit electronically, in addition to meeting other applicable requirements stated above, such signatures must meet the same signature, authentication, and identity-proofing standards set forth at 40 CFR § 3.2000(b) for electronic reports (including robust second-factor authentication). Compliance with this requirement can be achieved by submitting the application using the Colorado Environmental Online Service (CEOS) system.

##### 3. Change in Authorization to Sign

If an authorization is no longer accurate because a different individual or position has responsibility for the overall operation of the facility, a new authorization must be submitted to the division, prior to the re-authorization, or together with any reports, information, or applications to be signed by an authorized representative.

## L. REPORTING REQUIREMENTS

### 1. Planned Changes

The permittee shall give advance notice to the division, in writing, of any planned physical alterations or additions to the permitted facility in accordance with 40 CFR 122.41(l) and Regulation 61.8(5)(a). Notice is required only when:

- a. The alteration or addition to a permitted facility may meet one of the criteria for determining whether a facility is a new source in 40 CFR 122.29(b); or
- b. The alteration or addition could significantly change the nature or increase the quantity of pollutants discharged. This notification applies to pollutants which are subject neither to effluent limitations in the permit, nor to notification requirements under 40 CFR 122.41(a)(1).

### 2. Anticipated Non-Compliance

The permittee shall give advance notice to the division, in writing, of any planned changes in the permitted facility or activity that may result in noncompliance with permit requirements. The timing of notification requirements differs based on the type of non-compliance as described in subparagraphs 5, 6, 7, and 8 below.

### 3. Transfer of Ownership or Control

The permittee shall notify the division, in writing, ten (10) calendar days in advance of a proposed transfer of the permit. This permit is not transferable to any person except after notice is given to the division.

- a. Where a facility wants to change the name of the permittee, the original permittee (the first owner or operators) must submit a Notice of Termination.
- b. The new owner or operator must submit an application. See also signature requirements in Part II.K, above.
- c. A permit may be automatically transferred to a new permittee if:
  - i. The current permittee notifies the division in writing 30 calendar days in advance of the proposed transfer date; and
  - ii. The notice includes a written agreement between the existing and new permittee(s) containing a specific date for transfer of permit responsibility, coverage and liability between them; and
  - iii. The division does not notify the existing permittee and the proposed new permittee of its intent to modify, or revoke and reissue the permit.
  - iv. Fee requirements of the Colorado Discharge Permit System Regulations, Section 61.15, have been met.

### 4. Monitoring reports

Monitoring results must be reported at the intervals specified in this permit per the requirements of 40 CFR 122.41(l)(4).

### 5. Compliance Schedules

Reports of compliance or noncompliance with, or any progress reports on, interim and final requirements contained in any compliance schedule in the permit, shall be submitted on the date listed

in the compliance schedule section. The fourteen (14) calendar day provision in Regulation 61.8(4)(n)(i) has been incorporated into the due date.

6. Twenty-four Hour Reporting

In addition to the reports required elsewhere in this permit, the permittee shall report the following circumstances orally within twenty-four (24) hours from the time the permittee becomes aware of the circumstances, and shall mail to the division a written report containing the information requested within five (5) working days after becoming aware of the following circumstances:

- a. Circumstances leading to any noncompliance which may endanger health or the environment regardless of the cause of the incident;
- b. Circumstances leading to any unanticipated bypass which exceeds any effluent limitations in the permit;
- c. Circumstances leading to any upset which causes an exceedance of any effluent limitation in the permit;
- d. Daily maximum violations for any of the pollutants limited by Part I of this permit. This includes any toxic pollutant or hazardous substance or any pollutant specifically identified as the method to control any toxic pollutant or hazardous substance.
- e. The division may waive the written report required under subparagraph 6 of this section if the oral report has been received within 24 hours.

7. Other Non-Compliance

A permittee must report all instances of noncompliance at the time monitoring reports are due. If no monitoring reports are required, these reports are due at least annually in accordance with Regulation 61.8(4)(p). The annual report must contain all instances of non-compliance required under either subparagraph 5 or subparagraph 6 of this subsection.

8. Other Information

Where a permittee becomes aware that it failed to submit any relevant facts in a permit application, or submitted incorrect information in a permit application, or in any report to the Permitting Authority, it has a duty to promptly submit such facts or information.

M. BYPASS

1. Bypass Not Exceeding Limitations

The permittees may allow any bypass to occur which does not cause effluent limitations to be exceeded, but only if it also is for essential maintenance to assure efficient operation. These bypasses are not subject to the provisions of Part II.M.2 of this permit. See 40 CFR 122.41(m)(2).

2. Notice of Bypass

- a. Anticipated bypass. If the permittee knows in advance of the need for a bypass, the permittee must submit prior notice, if possible at least ten days before the date of the bypass. See 40 CFR §122.41(m)(3)(i) and/or Regulation 61.9(5)(c).
- b. Unanticipated bypass. The permittee must submit notice of an unanticipated bypass in accordance with Part II.L.6. See 40 CFR §122.41(m)(3)(ii).

3. Prohibition of Bypass

Bypasses are prohibited and the division may take enforcement action against the permittee for bypass, unless:

- a. The bypass is unavoidable to prevent loss of life, personal injury, or severe property damage;
- b. There were no feasible alternatives to the bypass, such as the use of auxiliary treatment facilities, retention of untreated wastes, or maintenance during normal periods of equipment downtime. This condition is not satisfied if adequate backup equipment should have been installed in the exercise of reasonable engineering judgment to prevent a bypass which occurred during normal periods of equipment downtime or preventive maintenance; and
- c. Proper notices were submitted to the division.

#### N. UPSET

##### 1. Effect of an upset

An upset constitutes an affirmative defense to an action brought for noncompliance with permit effluent limitations if the requirements of Part II.N.2. of this permit are met. No determination made during administrative review of claims that noncompliance was caused by upset, and before an action for noncompliance, is final administrative action subject to judicial review in accordance with Regulation 61.8(3)(j).

##### 2. Conditions Necessary for Demonstration of an Upset

A permittee who wishes to establish the affirmative defense of upset shall demonstrate through properly signed contemporaneous operating logs, or other relevant evidence that:

- a. An upset occurred and the permittee can identify the specific cause(s) of the upset;
- b. The permitted facility was at the time being properly operated and maintained; and
- c. The permittee submitted proper notice of the upset as required in Part II.L.6. (24- hour notice); and
- d. The permittee complied with any remedial measure necessary to minimize or prevent any discharge or sludge use or disposal in violation of this permit which has a reasonable likelihood of adversely affecting human health or the environment. In addition to the demonstration required above, a permittee who wishes to establish the affirmative defense of upset for a violation of effluent limitations based upon water quality standards shall also demonstrate through monitoring, modeling or other methods that the relevant standards were achieved in the receiving water.

##### 3. Burden of Proof

In any enforcement proceeding, the permittee seeking to establish the occurrence of an upset has the burden of proof.

#### O. RETENTION OF RECORDS

##### 1. Post-Expiration or Termination Retention

Copies of documentation required by this permit, including records of all data used to complete the application for permit coverage to be covered by this permit, must be retained for at least three years from the date that permit coverage expires or is terminated. This period may be extended by request of EPA at any time.

##### 2. On-site Retention

The permittee must retain an electronic version or hardcopy of the SWMP at the construction site from

the date of the initiation of construction activities to the date of expiration or inactivation of permit coverage; unless another location, specified by the permittee, is approved by the division.

#### P. REOPENER CLAUSE

##### 1. Procedures for Modification or Revocation

Permit modification or revocation of this permit or coverage under this permit will be conducted according to Regulation 61.8(8).

##### 2. Water Quality Protection

If there is evidence indicating that the stormwater discharges authorized by this permit cause, have the reasonable potential to cause or contribute to an excursion above any applicable water quality standard, the permittee may be required to obtain an individual permit, or the permit may be modified to include different limitations and/or requirements.

#### Q. SEVERABILITY

The provisions of this permit are severable. If any provisions or the application of any provision of this permit to any circumstances, is held invalid, the application of such provision to other circumstances and the application of the remainder of this permit shall not be affected.

#### R. NOTIFICATION REQUIREMENTS

##### 1. Notification to Parties

All notification requirements, excluding information submitted using the CEOS portal, shall be directed as follows:

- a. Oral Notifications, during normal business hours shall be to:  
Clean Water Compliance Section  
Water Quality Control Division  
Telephone: (303) 692-3500
- b. Written notification shall be to:  
Clean Water Compliance Section  
Water Quality Control Division  
Colorado Department of Public Health and Environment  
WQCD-WQP-B2  
4300 Cherry Creek Drive South  
Denver, CO 80246-1530

#### S. RESPONSIBILITIES

##### 1. Reduction, Loss, or Failure of Treatment Facility

The permittee has the duty to halt or reduce any activity if necessary to maintain compliance with the effluent limitations of the permit. It shall not be a defense for a permittee in an enforcement action that it would be necessary to halt or reduce the permitted activity in order to maintain compliance with the conditions of this permit.

#### T. OIL AND HAZARDOUS SUBSTANCE LIABILITY

Nothing in this permit shall be construed to preclude the institution of any legal action or relieve the permittee from any responsibilities, liabilities, or penalties to which the permittee is or may be subject to under Section 311 (Oil and Hazardous Substance Liability) of the CWA.

#### U. EMERGENCY POWERS

Nothing in this permit shall be construed to prevent or limit application of any emergency power of the division.

#### V. CONFIDENTIALITY

Any information relating to any secret process, method of manufacture or production, or sales or marketing data which has been declared confidential by the permittee, and which may be acquired, ascertained, or discovered, whether in any sampling investigation, emergency investigation, or otherwise, shall not be publicly disclosed by any member, officer, or employee of the Water Quality Control Commission or the division, but shall be kept confidential. Any person seeking to invoke the protection of this section shall bear the burden of proving its applicability. This section shall never be interpreted as preventing full disclosure of effluent data.

#### W. FEES

The permittee is required to submit payment of an annual fee as set forth in the 2016 amendments to the Water Quality Control Act. Section 25-8-502 (1.1) (b), and the Colorado Discharge Permit System Regulations 5 CCR 1002-61, Section 61.15 as amended. Failure to submit the required fee when due and payable is a violation of the permit and will result in enforcement action pursuant to Section 25-8-601 et. seq., C.R.S.1973 as amended.

#### X. DURATION OF PERMIT

The duration of a permit shall be for a fixed term and shall not exceed five (5) years. If the permittee desires to continue to discharge, a permit renewal application shall be submitted at least ninety (90) calendar days before this permit expires. Filing of a timely and complete application shall cause the expired permit to continue in force to the effective date of the new permit. The permit's duration may be extended only through administrative extensions and not through interim modifications. If the permittee anticipates there will be no discharge after the expiration date of this permit, the division should be promptly notified so that it can terminate the permit in accordance with Part I.A.3.i.

#### Y. SECTION 307 TOXICS

If a toxic effluent standard or prohibition, including any applicable schedule of compliance specified, is established by regulation pursuant to Section 307 of the Federal Act for a toxic pollutant which is present in the permittee's discharge and such standard or prohibition is more stringent than any limitation upon such pollutant in the discharge permit, the division shall institute proceedings to modify or revoke and reissue the permit to conform to the toxic effluent standard or prohibition



**APPENDIX 3**

**Exhibit A - Erosion and Sediment Control Field Inspection Report**

**Exhibit B - Corrective Action Report**

**Exhibit A  
Erosion and Sediment Control Field Inspection Report**

Project Name:	Date of Inspection:
Project Address/Location:	Time of Inspection:
Contractor:	Name of Inspector:

Reason for Inspection:

BMP for Erosion Control	Practice Used		Maintenance or Sediment Removal Required		Explain Required Action
	Yes	No	Yes	No	
Check Dams					
Concrete Washout Area					
Construction Fence					
Diversion Ditch/Swales/Berms					
Erosion Control Blankets					
Inlet Protection					
Reinforced Rock Berms					
Reinforced Rock Berms - Culvert					
Sediment Basin					
Sediment Control Log					
Seed & Mulch (Temp. or Permanent)					
Silt Fence					
Sodding					
Stabilized Staging Area					
Straw Bale Barrier					
Surface Roughening					
Vehicle Tracking Control Pad					

Contractor's Comments:

Inspector's Comments:

I certify this Erosion and Sediment Control Field Inspection Report is complete and accurate, to my knowledge and belief.

Inspector Signature and Date:	Reviewed By:
-------------------------------	--------------

**Exhibit B**  
**Corrective Action Report**

Site: \_\_\_\_\_

Inspector: \_\_\_\_\_

Date: \_\_\_\_\_

.....  
Erosion Control Measure/Facility Requiring Attention:

\_\_\_\_\_  
\_\_\_\_\_  
\_\_\_\_\_

Recommended Corrective Action:

\_\_\_\_\_  
\_\_\_\_\_  
\_\_\_\_\_

Scheduled Completion Date: \_\_\_\_\_ Date Completed: \_\_\_\_\_

.....

Erosion Control Measure/Facility Requiring Attention:

\_\_\_\_\_  
\_\_\_\_\_  
\_\_\_\_\_

Recommended Corrective Action:

\_\_\_\_\_  
\_\_\_\_\_  
\_\_\_\_\_

Scheduled Completion Date: \_\_\_\_\_ Date Completed: \_\_\_\_\_

.....

Erosion Control Measure/Facility Requiring Attention:

\_\_\_\_\_  
\_\_\_\_\_  
\_\_\_\_\_

Recommended Corrective Action:

\_\_\_\_\_  
\_\_\_\_\_  
\_\_\_\_\_

Scheduled Completion Date: \_\_\_\_\_ Date Completed: \_\_\_\_\_

**APPENDIX 4**

**Geotechnical and Pavement Design Report**

**Figure 2**

**SWMP Site Plan – Cover Sheet - C300**

**SWMP Site Plan - Initial Condition - C301**

**SWMP Site Plan – Interim Condition – C302**

**SWMP Site Plan - Final Condition – C303**

**Details of Construction CCMs – Exhibits C304 & C305**



**ENTECH**  
ENGINEERING, INC.

505 ELKTON DRIVE  
COLORADO SPRINGS, CO 80907  
PHONE (719) 531-5599

**GEOTECHNICAL AND PAVEMENT DESIGN REPORT  
2725 AKERS DRIVE – ADDITION AND RETAINING WALLS  
COLORADO SPRINGS, COLORADO**

Prepared for:  
**Bucher Design Studio, Inc.**  
**12325 Oracle Blvd., Suite 101**  
**Colorado Springs, Colorado 80921**

Attn: Nick Sallecchia

January 14, 2025

Respectfully Submitted,

ENTECH ENGINEERING, INC.

Zachary C. Gutierrez, E.I.T.  
Geotechnical Engineering Staff

Reviewed by:



Digitally signed by Joseph C Goode III  
Date: 01/14/25

Joseph C. Goode III, P.E.  
Sr. Engineer

ZCG:JCG/ed

**Table of Contents**

<b>1</b>	<b><i>Introduction</i></b> .....	<b>1</b>
<b>2</b>	<b><i>Project and Site Description</i></b> .....	<b>1</b>
<b>3</b>	<b><i>Subsurface Explorations and Laboratory Testing</i></b> .....	<b>1</b>
	3.1 Subsurface Exploration Program .....	1
	3.2 Laboratory Testing.....	2
<b>4</b>	<b><i>Subsurface Conditions</i></b> .....	<b>2</b>
	4.1 Soil and Bedrock.....	3
	4.2 Groundwater.....	3
<b>5</b>	<b><i>Geotechnical Evaluation and Recommendations</i></b> .....	<b>3</b>
	5.1 Shallow Foundations .....	4
	5.2 On-Grade Floor Slabs.....	5
	5.3 Design Parameters for Retaining Walls .....	5
	5.4 Seismic Site Classification .....	6
	5.5 Surface and Subsurface Drainage .....	6
<b>6</b>	<b><i>Pavement Design Recommendations</i></b> .....	<b>7</b>
	6.1 Pavement Subgrade Conditions .....	7
	6.2 Swell Mitigation.....	8
	6.3 Traffic Loading.....	8
	6.4 Pavement Designs.....	8
<b>7</b>	<b><i>Construction Recommendations</i></b> .....	<b>9</b>
	7.1 Earthwork Recommendations for Structures.....	9
	7.1.1 Subgrade Preparation .....	9
	7.1.2 Granular Fill .....	9
	7.1.3 Fill Placement and Compaction.....	10
	7.2 Pavements.....	10
	7.2.1 Pavement Subgrade Preparation .....	10
	7.2.2 Aggregate Base Course and Recycled Concrete Base .....	11
	7.3 Excavation Potential .....	11
	7.4 Excavation Stability.....	11
	7.5 Utility Trench Backfill .....	11
	7.6 General Backfill.....	11
	7.7 Concrete Degradation Due to Sulfate Attack.....	12
	7.8 Winter Construction .....	12
	7.9 Foundation Excavation and Construction Observation.....	12
<b>8</b>	<b><i>Closure</i></b> .....	<b>13</b>

**Table of Contents (cont.)**

**Figures**

*Figure 1: Vicinity Map*

*Figure 2: Site and Exploration Plan*

*Figure 3: Perimeter Drain Detail*

**List of Appendices**

*Appendix A: Test Boring Logs*

*Appendix B: Laboratory Test Results*

*Appendix C: Pavement Design Calculations*



## **1 Introduction**

Entech Engineering Inc. (Entech) completed this geotechnical and pavement design report for a new building addition, retaining walls, and associated site improvements in Colorado Springs, Colorado. This report describes the subsurface exploration program conducted for the planned commercial addition and provides recommendations for foundation design, retaining walls, pavement sections, and construction. Our services were completed for Bucher Design Studio, Inc. in accordance with our geotechnical service agreements dated November 26, 2024. The contents of this report, including the geotechnical evaluation and recommendations, are subject to the limitations and assumptions presented in Section 8.

## **2 Project and Site Description**

We understand that the project will consist of the construction of a new 7,100-square-foot addition, three retaining walls, and associated site improvements at the existing commercial property located at 2725 Akers Drive in Colorado Springs, Colorado. Retaining walls are proposed along the northern, southern, and western edges of the site. The location of the project site is shown on the Vicinity Map (Figure 1).

At the time of drilling, the property was an occupied commercial property with an existing warehouse located centrally on the property with variable grades across the site. Vegetation was absent due to the previous asphalt recovery processes conducted on the site. The site is surrounded by commercial properties with a residential neighborhood to the west across Akers Drive. Building loads are expected to be light to moderate.

## **3 Subsurface Explorations and Laboratory Testing**

### **3.1 Subsurface Exploration Program**

Subsurface conditions at the project site were explored by nine test borings, designated TB-1 through TB-9, drilled on December 13 and 16, 2024 at the approximate locations shown on the Site and Exploration Plan (Figure 2). Two borings (TB-1 and TB-2) were drilled in the addition footprint and five (TB-3 through TB-7) were drilled for the three retaining walls. Two additional borings (TB-8 and TB-9) were drilled in the parking lot and drive lanes to provide pavement design recommendations. The borings in the building footprint and at the proposed retaining wall locations were drilled to depths of 20 feet below the existing ground surface (bgs), and the borings



in the parking and drive areas were drilled to depths of 10 feet bgs. The drilling was performed using a truck-mounted, continuous flight auger drill rig supplied and operated by Entech. Descriptive boring logs providing the lithologies of the subsurface conditions encountered during drilling are presented in Appendix A. Groundwater levels were measured in each of the open boreholes at the conclusion of, and subsequent to, drilling.

Soil and bedrock samples were obtained from the borings utilizing the Standard Penetration Test (ASTM D1586) using a split-barrel California sampler. Results of the Standard Penetration Test (SPT) are included on the boring logs in terms of N-values expressed in blows per foot (bpf). Soil and bedrock samples recovered from the borings were visually classified and recorded on the boring logs. The soil and bedrock classifications were later verified utilizing laboratory testing and grouped by soil type. The soil and bedrock type numbers are included on the boring logs. It should be understood that soil and bedrock descriptions shown on the boring logs may vary between boring location and sample depths. It should also be noted that the lines of stratigraphic separation shown on the boring logs represent approximate boundaries between soil and bedrock types, and the actual stratigraphic transitions may be more gradual or variable with location.

### **3.2 Laboratory Testing**

Water content testing (ASTM D2216) was performed on the samples recovered from the borings, and the results are shown on the boring logs. Grain-Size Analysis (ASTM D422) and Atterberg Limits testing (ASTM D4318) were performed on selected samples to assist in classifying the materials encountered in the borings. One-dimensional swell/collapse testing (ASTM D4546) was performed to evaluate the expansive characteristics and collapse potential characteristics. Soluble sulfate testing was performed on select soil samples to evaluate the potential for below-grade degradation of concrete due to sulfate attack.

For pavement design, a Standard Proctor (ASTM D698) and California Bearing Ratio (CBR) test (ASTM D1883) were completed on a bulk sample from the roadway subgrade. The Laboratory Testing Results are presented in Appendix B and summarized in Table B-1.

## **4 Subsurface Conditions**

Two primary soil types were encountered in the test borings drilled for the subsurface investigation. Each soil type was classified in accordance with the Unified Soil Classification System (USCS) and the American Association of State Highway and Transportation Officials

(AASHTO) soil classification system using the laboratory testing results and the observations made during drilling.

#### **4.1 Soil and Bedrock**

Soil Type 1 classified as clayey sand or silty sand (SM, SC). The medium dense sand was encountered in all test borings at ground surface to 9 feet bgs and extended to depths of 9 feet bgs or to the termination depth of the boring at 10 or 20 feet. One-dimensional swell or collapse testing on a sample of the sands resulted in volume changes of -1.8% to 0.6% indicating low to moderate expansion and collapse potential.

Pavement subgrade soils generally consisted of Soil Type 1 which classified as AASHTO A-6.

Soil Type 1A classified as clayey sand fill (SC). The sand fill was encountered in the majority of test borings at ground surface and extended to depths of 1.5 to 2 feet bgs. The on-site sands are expected to have a low potential for expansion or collapse.

Soil Type 2 classified as native sandy clay (CL). The stiff native clay was encountered in TB-4 at the existing ground surface and extended to a depth of 9 feet bgs and was encountered in TB-6 at 9 feet bgs and extended to the termination depth of the boring at 20 feet bgs. The encountered clay is expected to have low to moderate expansion potential.

#### **4.2 Groundwater**

Groundwater was encountered in test borings TB-1 and TB-3 during our subsurface exploration program at 19.5 and 19 feet bgs, respectively. It should be noted that groundwater levels could change due to seasonal variations, changes in land runoff characteristics, and future development of nearby areas.

## **5 Geotechnical Evaluation and Recommendations**

*The following discussion is based on the subsurface conditions encountered in the borings drilled on the planned lot for construction. If subsurface conditions different from those described herein are encountered during construction, or if the project elements change from those described, Entech should be notified so that the evaluation and recommendations presented can be reviewed and revised if necessary.*

As discussed in Section 2, we understand that the site will be developed with a new commercial addition, retaining walls, and associated site improvements. The proposed structure is expected



to have a shallow foundation system. Anticipated subsurface conditions at footing grade are expected to consist of native granular soil or recompacted onsite granular material and are suitable for support of shallow foundations.

### **5.1 Shallow Foundations**

For shallow foundation design, continuous spread footings are recommended to have a minimum width of 16 inches, and individual column footings for main support beams should have minimum plan dimensions of 24 inches on each side in order to avoid punching failure into the supporting subgrade soils. Subgrades should be prepared as discussed in Section 7.1.1. Refer to Exhibit 1 for the recommended allowable bearing capacity values. Shallow foundations shall not be placed on soils with differential bearing capacities, loose granular soil, or uncontrolled fill. Undocumented, uncontrolled fill was encountered throughout the site to depths of up to 2 feet. We anticipate that this fill will be penetrated by the proposed shallow foundations. If grades on the site are raised, the undocumented fill material should be overexcavated and recompacted below foundation components and slabs on grade.

Foundation walls should be designed to resist lateral pressures generated by the soils used for wall backfill. Recommended active equivalent fluid density parameters for the on-site granular soils are provided in Exhibit 1. Clay/silt soils (more than 50% passing the No. 200 sieve) are not recommended for backfill against the walls. It should be noted that this value applies to level backfill conditions. If sloping backfill conditions exist, pressures will increase substantially depending on the conditions adjacent to the walls. Surcharge loading should also be considered in wall designs. Equivalent fluid pressures for sloping conditions should be determined on an individual basis. Exterior footings should extend a minimum of 30 inches below the adjacent exterior site grade for frost protection.

**Exhibit 1: Foundation Design Parameters**

Design Parameter	Value
<b>Allowable Bearing Capacity <sup>1</sup></b>	
Medium Dense Native Sand or Granular Fill	2,200 psf
<b>Lateral Earth Pressure Equivalent Fluid Density <sup>2</sup></b>	
Active Conditions – On-Site Granular Backfill	45 pcf

*pcf = pounds per cubic foot; psf = pounds per square foot*

Notes:

1. Assumes a minimum embedment of 30 inches for frost protection.
2. Assumes level backfill conditions.

Actual bearing capacities will be verified at the time of the open excavation observation (Section 7.9).

**5.2 On-Grade Floor Slabs**

On-grade floor slabs for the planned structure should be supported on native, medium dense sand or 2 feet of moisture-conditioned and recompacted site or imported granular soils prepared in accordance with Section 7.1.1, and any loose soils or uncontrolled fill encountered will require removal.

Grade-supported floor slabs should be separated from other building structural components and utility penetrations to allow for possible future vertical movement. Interior partition walls should be constructed in such a manner so as not to transfer slab movement into the overlying floor(s) and/or roof members, should slab movement occur. Control joints in grade-supported slabs are recommended at 10- to 15-foot perpendicular spacings to control cracking. If slab movement cannot be tolerated, a structural floor system should be used.

**5.3 Design Parameters for Retaining Walls**

Based on the material encountered in the test borings, the proposed retaining walls can be supported on a gravel leveling pad (for segmental walls) or a shallow concrete footing (for cast-in-place concrete walls), bearing on native medium dense granular fill. A bearing capacity for the site granular material is presented in Exhibit 2. Any loose or uncontrolled fill material encountered in the wall subgrade should be removed completely and recompacted under controlled conditions. Any fill material should be placed in finished lifts no thicker than 6 inches, compacted to at least



95% of the Modified Proctor (ASTM D1557) maximum dry density at a moisture content conducive to compaction, usually within +/- 2% of optimum.

Retaining walls should be designed to resist lateral earth pressures generated by the soils used for wall backfill. Equivalent hydrostatic fluid pressures are also provided in Exhibit 2 for the approved site soils. It should be noted that this value applies to level backfill conditions. Pressures will increase substantially depending on the conditions adjacent to the wall. Surcharge loading should be considered in wall design. The following values are recommended for use in the design of the retaining wall associated with this project:

**Exhibit 2: Retaining Wall Design Recommendations**

Design Parameter (On-site granular soil)	Value
Equivalent Fluid Pressure (active case), pcf	45
Equivalent Fluid Pressure (passive case), pcf	300
Equivalent Fluid Pressure (at rest), pcf	65
Soil Density, pcf	120
Angle of Internal Friction, degrees	28
Coefficient of Sliding (Concrete & Sand)	0.35
Soil Bearing Capacity	2,200 psf

The wall should include a subsurface drain installed according to the design drawings in order to avoid accumulation of hydrostatic pressures on the wall.

**5.4 Seismic Site Classification**

Based on the subsurface conditions encountered at the site, and in accordance with Section 1613 of the 2021 *International Building Code (IBC)*, the site meets the conditions of a Site Class D.

**5.5 Surface and Subsurface Drainage**

Positive surface drainage is recommended around the building’s perimeter to minimize infiltration of surface water into the supporting foundation soils. A minimum ground surface slope of 5% in the first 10 feet adjacent to exterior foundation walls is recommended for unpaved areas. For paved areas and other impervious surfaces, a minimum slope of 2% is adequate. All roof drains and gutter downspouts should be extended to discharge well beyond the building’s foundation backfill zone or be connected to a storm sewer system.

To help minimize infiltration of water into the foundation zone, vegetative plantings placed close to foundation walls should be limited to those species having low watering requirements, and irrigated grass should not be located within 5 feet of the foundation. Sprinklers are not recommended to discharge water within 5 feet of foundations. Irrigation near foundations should be limited to the minimum amount sufficient to maintain vegetation. The application of more irrigation water than necessary can increase the potential for slab and foundation movement.

Perimeter drains are recommended for usable space below grade (areas where the interior slab or bottom of the crawl space is below the exterior grade). A typical perimeter drain detail is shown in Figure 3.

## 6 Pavement Design Recommendations

Pavement design recommendations were made in accordance with the *City of Colorado Springs Pavement Design Criteria Manual*.

### 6.1 Pavement Subgrade Conditions

Two test borings (TB-8 and TB-9) were drilled to depths of approximately 10 feet below the existing subgrade surface in the parking lot and drive lanes. The soils at the roadway subgrade depth consisted of silty sand and clayey sand. The sands classified as A-6 using the AASHTO classification system.

California Bearing Ratio (CBR) testing was performed on a representative bulk sample of the clayey sand (Soil Type 1) from TB-8 to determine the support characteristics of the subgrade soils for the pavement sections. The results of the CBR testing are presented in Appendix B and summarized in Exhibit 2.

**Exhibit 2: Pavement Subgrade Laboratory Summary**

Design Parameter	Value
Soil Type	1-Clayey Sand
CBR at 95%	4.7
Design CBR	4.7
Liquid Limit	31
Plasticity Index	10
Percent Passing 200	43.5
AASHTO Classification	A-6
Group Index	1
Unified Soils Classification	SC



## 6.2 Swell Mitigation

The City of Colorado Springs requires swell mitigation of expansive soils criteria for soils with swell testing results greater than 4% under a 200 pounds per square foot (psf) surcharge. Based on the swell testing and classification of the subgrade soils, mitigation for expansive soils is not required on this site.

## 6.3 Traffic Loading

Traffic data is not available for the parking lot and access road. Based on the Colorado Asphalt Pavement Association (CAPA) *Guideline for the Design and Construction of Asphalt Parking Lots in Colorado* (2006), an 18-kip equivalent single axle loading (ESAL) of 50,000 is appropriate for moderate traffic levels which includes passenger cars and light trucks.

## 6.4 Pavement Designs

The recommended pavement sections were determined utilizing the *City of Colorado Springs Pavement Design Criteria Manual*, the CBR testing, and default ESAL. Design parameters used in the pavement analysis are presented in Exhibit 2.

**Exhibit 2: Pavement Design Parameters**

Design Parameter	Values
Reliability	85%
Standard Deviation	0.44
Serviceability Loss ( $\Delta$ psi)	2.5
Design CBR	4.7
Resilient Modulus - Soil Type 1	7,050 psi
Structural Coefficients	
Hot Mix Asphalt	0.44
Aggregate Base Course	0.12
Recycled Concrete Base	0.12

Pavement sections are presented below in Exhibit 4. Any additional grading may result in subgrade soils with different support characteristics. The following pavement sections should be re-evaluated if additional grading is performed.

#### Exhibit 4: Recommended Pavement Sections

Pavement Area	Design ESAL	Alternative <sup>1</sup>
Parking Areas and Drive Lanes	50,000	1. 4.0 inches HMA over 4.0 inches ABC/RCB

*ABC = Aggregate Base Course; ESAL = Equivalent Single Axle Loads; HMA = Hot Mix Asphalt; RCB = Recycled Concrete Base*

**Notes:**

1. All pavement alternatives meet the minimum sections required per the *City of Colorado Springs Pavement Design Criteria Manual*.
2. Full-depth sections are not allowed within the City of Colorado Springs.

## 7 Construction Recommendations

### 7.1 Earthwork Recommendations for Structures

#### 7.1.1 Subgrade Preparation

We anticipate that the shallow foundations will penetrate the undocumented fill encountered throughout the site. We recommend that the undocumented fill be overexcavated and recompacted in place in the slab-on-grade areas or in areas where grades are raised and the bottom of shallow foundations do not penetrate the undocumented fill.

Where applicable, undocumented fill should be fully penetrated (anticipated depth of 2 feet) to expose a dense and unyielding native subgrade. Once suitable materials are encountered, the subgrade should be scarified to a depth of 6 inches and then recompacted to 95% of the Modified Proctor (ASTM D1557) maximum dry density within +/- 2% of the optimum moisture content. The overexcavated material can then be replaced in 6-inch lifts and recompacted to the same specifications as described above. The suitability of subgrades and/or overexcavation depth should be determined during the excavation observation.

Foundations and on-grade floor slabs may be placed on controlled, well-compacted, site or imported granular fill. All soil beneath the foundation and slabs should be free of organics, debris, and cobbles larger than 3 inches in diameter.

#### 7.1.2 Granular Fill

Granular fill placed beneath foundation components and floor slabs shall consist of nonexpansive, granular soil, free of organic matter, unsuitable materials, debris, and cobbles greater than 3 inches in diameter. On-site granular soils may be used as granular fill. Entech should approve



any imported granular or structural fill to be used within the foundation area prior to delivery to the site.

### **7.1.3 Fill Placement and Compaction**

All granular fill placed within the foundation area should be compacted to a minimum of 95% of the Modified Proctor (ASTM D1557) maximum dry density at +/- 2% of optimum moisture content. Fill material should be placed in horizontal lifts such that each finished lift has a compacted thickness of 6 inches or less as determined by ASTM D1557. Mechanical methods can be used for placement and compaction of fill; however, heavy equipment should be kept at a distance from foundation walls and below slab infrastructure to avoid overstressing. No water flooding techniques of any type should be used for compaction or placement of foundation or floor slab fill material.

Fill placement and compaction beneath and around foundations should be observed and tested by Entech during construction. Density tests should be performed frequently to verify compaction with the first density test performed at the overexcavated subgrade elevation and with additional testing once each 12 to 18 inches of granular fill has been placed.

## **7.2 Pavements**

Pavement design recommendations provided herein are contingent on good construction practices, and poor construction techniques may result in poor performance. Our analyses assumed that this project will be constructed according to the *Colorado Springs Engineering Criteria Manual* and the *Pikes Peak Regional Asphalt Paving Specifications*.

### **7.2.1 Pavement Subgrade Preparation**

Proper subgrade preparation is required for adequate pavement performance. Paving areas should be cleared of all deleterious materials including but not limited to existing pavements, utility poles, and fence poles. Surface vegetation should be removed by stripping, with the depth to be field determined.

The final subgrade surface should be scarified to a depth of 12 inches and then recompact to a minimum of 95% of the Modified Proctor (ASTM D1557) maximum dry density at +/- 2% of optimum moisture content. The compacted surface below pavements should be proof-rolled with a fully loaded, tandem-axle, 10-yard dump truck or equivalent. Any areas that are delineated to be soft, loose, or yielding during proof-rolling should be removed and reconditioned or replaced.

We do not anticipate issues with the subgrade in regard to shallow water, frost-susceptible soils, groundwater or drainage conditions, or cold weather construction.

### **7.2.2 Aggregate Base Course and Recycled Concrete Base**

ABC or RCB materials shall conform to the *Colorado Springs Standard Specifications Manual*, Section 300 Aggregate Base Course. ABC or RCB materials should be compacted to a minimum of 95% of the Modified Proctor (ASTM D1557) maximum dry density within +/-2% of optimum moisture content.

### **7.3 Excavation Potential**

Excavation of the upper granular soils should be feasible with rubber-tired equipment.

### **7.4 Excavation Stability**

Excavation sidewalls must be properly sloped, benched, and/or otherwise supported in order to maintain stable conditions. All excavation openings and work completed therein shall conform to OSHA Standards as put forward in CFR 29, Part 1926.650-652, (Subpart P).

### **7.5 Utility Trench Backfill**

Trench backfill placement should be performed in accordance with Colorado Springs specifications. All excavation and excavation shoring/bracing should be performed in accordance with OSHA guidelines.

Fill placement and compaction in utility trenches should be observed and tested by Entech during construction. Fill should be placed in horizontal lifts having a compacted thickness of 6 inches or less and at a water content conducive to adequate compaction, within +/-2% of optimum water content. No water flooding techniques of any type should be used for compaction or placement of utility trench fill.

### **7.6 General Backfill**

Any areas to receive general grading fill should have all topsoil, organic material, and debris removed. Fill must be properly benched into existing slopes in order to be adequately compacted. The fill-receiving surface should be scarified to a depth of 12 inches and then recompact to a minimum of 95% of the Modified Proctor (ASTM D1557) maximum dry density at +/-2% of optimum moisture content or the Standard Proctor (ASTM D698) for cohesive soils before the addition of new fill. Fill should be placed in thin lifts not to exceed 6 inches in thickness. Fill material



should be free of vegetation and other unsuitable material and should not contain cobbles or fragments larger than 3 inches. Topsoil and strippings should be segregated from all other fill sources on the site. Fill placement and compaction beneath and around foundations, in utility trenches, or beneath roadways or other structural features of the project should be observed and tested by Entech during construction.

### **7.7 Concrete Degradation Due to Sulfate Attack**

Sulfate solubility testing was conducted on several samples recovered from the test borings to evaluate the potential for sulfate attack on concrete placed below surface grade. The test results indicated less than 0.01 and 0.00% soluble sulfate (by weight). The test results indicate the sulfate component of the in-place soils presents a negligible exposure threat to concrete placed below the site grade.

Type 1L or Type II cement is recommended for concrete on the site. To further avoid concrete degradation during construction, it is recommended that concrete not be placed on frozen or wet ground. Care should be taken to prevent the accumulation or ponding of water in the foundation excavation prior to the placement of concrete. If standing water is present in the foundation excavation, it should be removed by ditching to sumps and pumping the water away from the foundation area prior to concrete placement. If concrete is placed during periods of cold temperatures, the concrete must be kept from freezing. This may require covering the concrete with insulated blankets and adding heat to prohibit freezing.

### **7.8 Winter Construction**

In the event construction of the planned facility occurs during winter, foundations and subgrades should be protected from freezing conditions. Concrete should not be placed on frozen soil and once concrete has been placed, it should not be allowed to freeze. Similarly, once exposed, the foundation subgrade should not be allowed to freeze. During site grading and subgrade preparation, care should be taken to eliminate the burial of snow, ice, or frozen material within the planned construction area.

### **7.9 Foundation Excavation and Construction Observation**

Subgrade preparation for building foundations should be observed by Entech prior to construction of the footings and floor slabs in order to verify that (1) no anomalies are present, (2) materials similar to those described in this report have been encountered or placed, and (3) no soft spots, expansive or organic soil, or debris are present in the foundation area prior to concrete placement

or backfilling. Entech should make final recommendations for overexcavation, if required, and foundation drainage at the time of excavation observation, if necessary.

In addition, Entech should observe and document placement and compaction of utility bedding and trench backfill.

## **8 Closure**

The subsurface investigation, geotechnical evaluation, and recommendations presented in this report are intended for use by Bucher Design Studio with application to the planned new addition, retaining walls, and associated site improvements located in Colorado Springs, Colorado. In conducting the subsurface investigation, laboratory testing, engineering evaluation, and reporting, Entech Engineering, Inc. endeavored to work in accordance with generally accepted professional geotechnical and geologic practices and principles consistent with the level of care and skill ordinarily exercised by members of the geotechnical profession currently practicing in the same locality and under similar conditions. No other warranty, expressed or implied, is made. During final design and/or construction, if conditions are encountered that appear different from those described in this report, Entech Engineering, Inc. requests to be notified so that the evaluation and recommendations presented herein can be reviewed and modified as appropriate.

If there are any questions regarding the information provided herein, or if Entech Engineering, Inc. can be of further assistance, please do not hesitate to contact us.



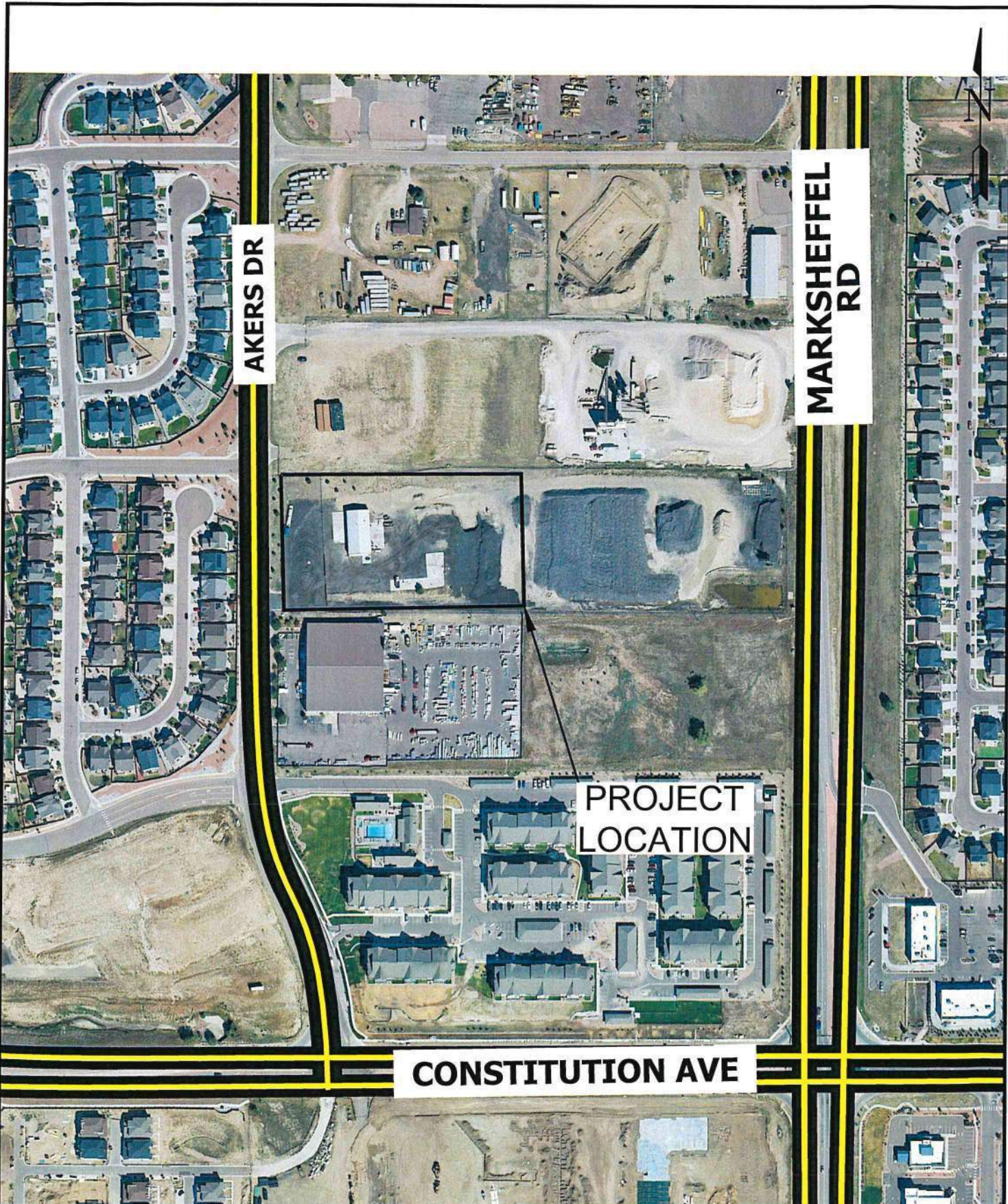

**AKERS DR**

**MARKSHEFFEL  
RD**

**PROJECT  
LOCATION**

**CONSTITUTION AVE**



**VICINITY MAP**  
2725 AKERS DRIVE  
BUCHER DESIGN STUDIO

JOB NO.  
242065  
**FIG. 1**



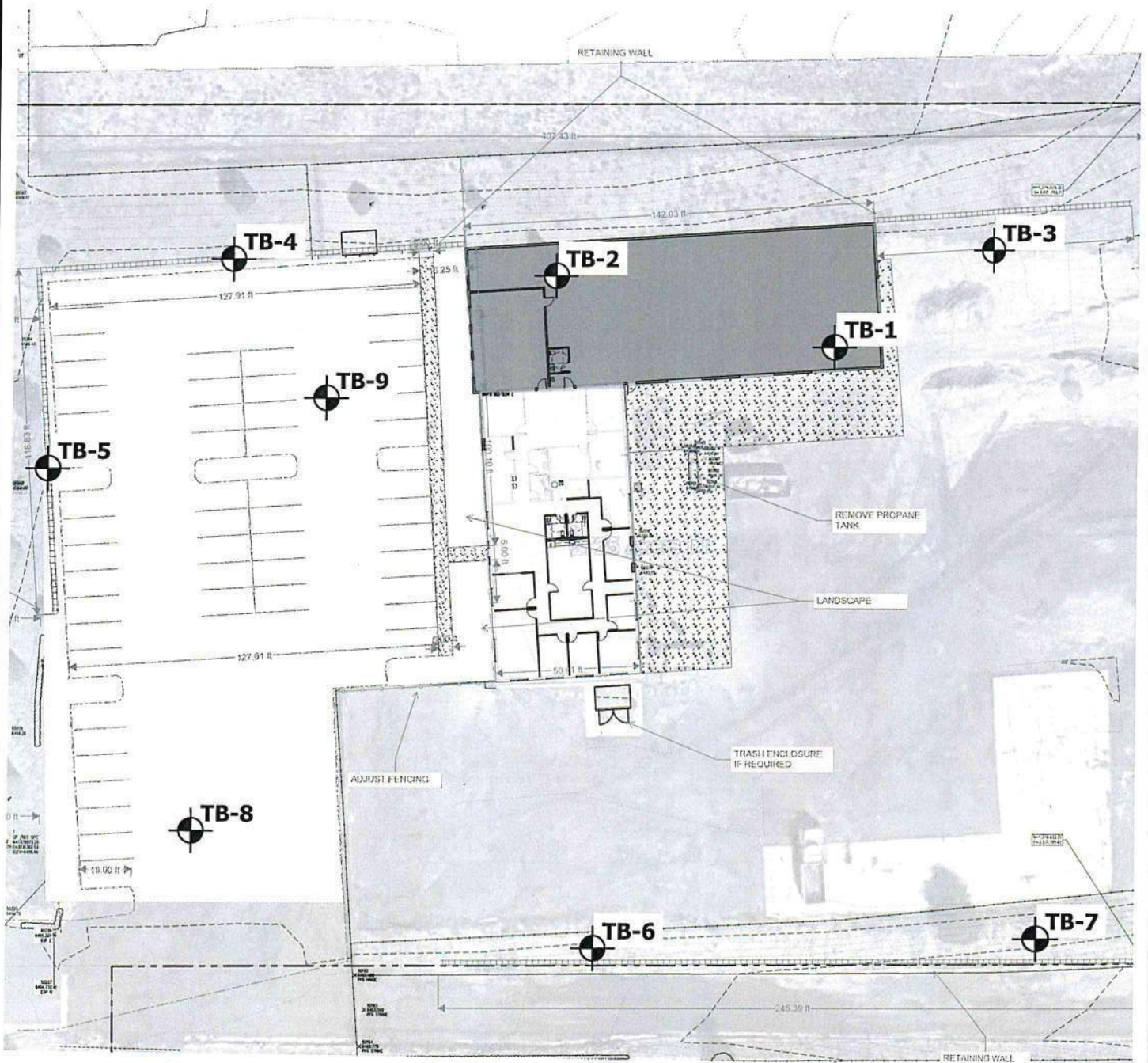

 **TB- APPROXIMATE TEST BORING LOCATION AND NUMBER**



### SITE AND EXPLORATION PLAN

2725 AKERS DRIVE  
BUCHER DESIGN STUDIO

JOB NO.  
242065

FIG. 2

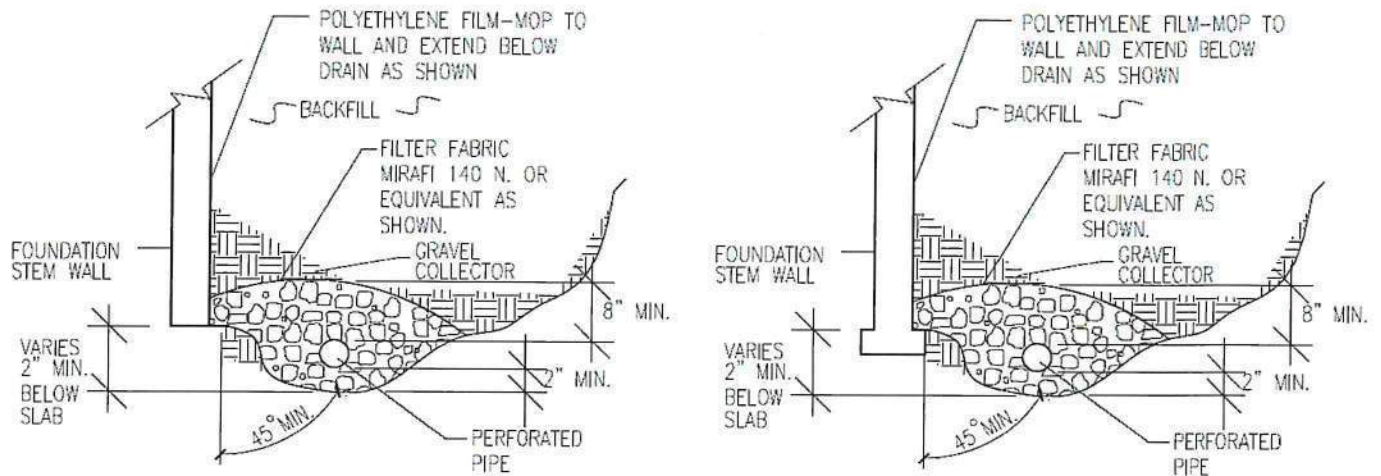

NOTES:

-GRAVEL SIZE IS RELATED TO DIAMETER OF PIPE PERFORATIONS-85% GRAVEL GREATER THAN 2x PERFORATION DIAMETER.

-PIPE DIAMETER DEPENDS UPON EXPECTED SEEPAGE. 4-INCH DIAMETER IS MOST OFTEN USED.

-ALL PIPE SHALL BE PERFORATED PLASTIC. THE DISCHARGE PORTION OF THE PIPE SHOULD BE NON-PERFORATED PIPE.

-FLEXIBLE PIPE MAY BE USED UP TO 8 FEET IN DEPTH, IF SUCH PIPE IS DESIGNED TO WITHSTAND THE PRESSURES. RIGID PLASTIC PIPE WOULD OTHERWISE BE REQUIRED.

-MINIMUM GRADE FOR DRAIN PIPE TO BE 1% OR 3 INCHES OF FALL IN 25 FEET.

-DRAIN TO BE PROVIDED WITH A FREE GRAVITY OUTFALL, IF POSSIBLE. A SUMP AND PUMP MAY BE USED IF GRAVITY OUT FALL IS NOT AVAILABLE.



**PERIMETER DRAIN DETAIL**

2725 AKERS DRIVE  
BUCHER DESIGN STUDIO

JOB NO.  
242065

**FIG. 3**



## **APPENDIX A: Test Boring Logs**



TEST BORING 1  
DATE DRILLED 12/13/2024

TEST BORING 2  
DATE DRILLED 12/13/2024

REMARKS

REMARKS

WATER @ 19.5', 12/17/24

FILL 0-2', SAND, CLAYEY, BROWN

SAND, SILTY, BROWN to LIGHT BROWN, MEDIUM DENSE, MOIST

SAND, CLAYEY, LIGHT BROWN, MEDIUM DENSE, MOIST

Depth (ft)	Symbol	Samples	Blows per foot	Watercontent %	Soil Type
0-2	Diagonal lines				1A
5	Diagonal lines	13	18.5	1	
5	Diagonal lines	11	10.7	1	
10	Diagonal lines	16	18.2	1	
15	Diagonal lines	16	10.4	1	
20	Diagonal lines	24	17.7	1	

DRY TO 20', 12/17/24

SAND, CLAYEY, LIGHT BROWN, MEDIUM DENSE, MOIST

Depth (ft)	Symbol	Samples	Blows per foot	Watercontent %	Soil Type
0-2	Diagonal lines				
5	Diagonal lines	12	19.6	1	
5	Diagonal lines	12	15.2	1	
10	Diagonal lines	16	9.4	1	
15	Diagonal lines	16	9.4	1	
20	Diagonal lines	19	9.4	1	



TEST BORING LOGS

2725 AKERS DRIVE  
BUCHER DESIGN STUDIO

JOB NO.  
242065

FIG. A-1

TEST BORING 3  
 DATE DRILLED 12/13/2024

TEST BORING 4  
 DATE DRILLED 12/13/2024

REMARKS

REMARKS

WATER @ 19', 12/13/24

SAND, CLAYEY, BROWN to LIGHT BROWN, MEDIUM DENSE, MOIST

DRY TO 20', 12/17/24

CLAY, SANDY, BROWN, STIFF, MOIST

Depth (ft)	Symbol	Samples	Blows per foot	Watercontent %	Soil Type	Depth (ft)	Symbol	Samples	Blows per foot	Watercontent %	Soil Type
5			11	12.0	1	5			8	10.1	2
5			13	12.0	1	5			13	13.6	2
10			16	13.3	1	10			15	10.0	1
15			18	10.3	1	15			21	8.5	1
20			19	13.4	1	20			20	12.2	1



TEST BORING LOGS

2725 AKERS DRIVE  
 BUCHER DESIGN STUDIO

JOB NO.  
 242065

FIG. A-2

TEST BORING 5  
 DATE DRILLED 12/16/2024

TEST BORING 6  
 DATE DRILLED 12/16/2024

REMARKS

REMARKS

DRY TO 19.5', 12/17/24

DRY TO 20', 12/17/24

FILL 0-1.5', SAND, CLAYEY, BROWN

FILL 0-2', SAND, CLAYEY, BROWN

SAND, CLAYEY, BROWN to LIGHT  
 BROWN, MEDIUM DENSE, MOIST

SAND, CLAYEY, BROWN to LIGHT  
 BROWN, MEDIUM DENSE, MOIST

Depth (ft)	Symbol	Samples	Blows per foot	Watercontent %	Soil Type
0-1.5'	[Symbol]				1A
5	[Symbol]		13	19.2	1
5	[Symbol]		18	16.4	1
10	[Symbol]		11	12.4	1
15	[Symbol]		15	13.0	1
20	[Symbol]		21	8.7	1

Depth (ft)	Symbol	Samples	Blows per foot	Watercontent %	Soil Type
0-2'	[Symbol]				1A
5	[Symbol]		10	15.8	1
5	[Symbol]		11	18.5	1
10	[Symbol]		12	15.8	2
15	[Symbol]		11	15.4	2
20	[Symbol]		14	13.0	2



**TEST BORING LOGS**

2725 AKERS DRIVE  
 BUCHER DESIGN STUDIO

JOB NO.  
 242065

**FIG. A-3**

TEST BORING 7  
 DATE DRILLED 12/16/2024

TEST BORING 8  
 DATE DRILLED 12/16/2024

REMARKS

REMARKS

DRY TO 19.5', 12/17/24

DRY TO 10', 9/16/24

FILL 0-1.5', SAND, CLAYEY, BROWN

FILL 0-1.5', SAND, CLAYEY, BROWN

SAND, CLAYEY, BROWN to LIGHT  
 BROWN, MEDIUM DENSE, MOIST

SAND, CLAYEY, BROWN to LIGHT  
 BROWN, MEDIUM DENSE, MOIST

Depth (ft)	Symbol	Samples	Blows per foot	Watercontent %	Soil Type
0-1.5	Diagonal lines				1A
1.5-2.5	Diagonal lines		10	9.6	1
2.5-3.5	Diagonal lines		12	10.6	1
3.5-4.5	Diagonal lines				
4.5-5.5	Diagonal lines				
5.5-6.5	Diagonal lines				
6.5-7.5	Diagonal lines				
7.5-8.5	Diagonal lines				
8.5-9.5	Diagonal lines				
9.5-10.5	Diagonal lines		18	10.4	1
10.5-11.5	Diagonal lines				
11.5-12.5	Diagonal lines				
12.5-13.5	Diagonal lines				
13.5-14.5	Diagonal lines				
14.5-15.5	Diagonal lines		16	7.2	1
15.5-16.5	Diagonal lines				
16.5-17.5	Diagonal lines				
17.5-18.5	Diagonal lines				
18.5-19.5	Diagonal lines				
19.5-20	Diagonal lines		14	10.0	1

Depth (ft)	Symbol	Samples	Blows per foot	Watercontent %	Soil Type
0-1.5	Diagonal lines				1A
1.5-2.5	Diagonal lines		11	11.8	1
2.5-3.5	Diagonal lines				
3.5-4.5	Diagonal lines				
4.5-5.5	Diagonal lines		11	13.0	1
5.5-6.5	Diagonal lines				
6.5-7.5	Diagonal lines				
7.5-8.5	Diagonal lines				
8.5-9.5	Diagonal lines		9	18.6	1
9.5-10.5	Diagonal lines				
10.5-11.5	Diagonal lines				
11.5-12.5	Diagonal lines				
12.5-13.5	Diagonal lines				
13.5-14.5	Diagonal lines				
14.5-15.5	Diagonal lines				
15.5-16.5	Diagonal lines				
16.5-17.5	Diagonal lines				
17.5-18.5	Diagonal lines				
18.5-19.5	Diagonal lines				
19.5-20	Diagonal lines				



TEST BORING LOGS

2725 AKERS DRIVE  
 BUCHER DESIGN STUDIO

JOB NO.  
 242065

FIG. A-4

TEST BORING 9  
 DATE DRILLED 12/16/2024

REMARKS

DRY TO 10', 9/16/24

SAND, CLAYEY, BLACK, MEDIUM  
 DENSE, MOIST

Depth (ft)	Symbol	Samples	Blows per foot	Watercontent %	Soil Type
5			19	14.9	1
10			11	12.4	1
15			14	15.3	1



TEST BORING LOGS

2725 AKERS DRIVE  
 BUCHER DESIGN STUDIO

JOB NO.  
 242065

FIG. A-5



## **APPENDIX B: Laboratory Test Results**



**TABLE B-1**  
**SUMMARY OF LABORATORY TEST RESULTS**



SOIL TYPE	TEST BORING NO.	DEPTH (FT)	WATER (%)	DRY DENSITY (PCF)	PASSING NO. 200 SIEVE (%)	LIQUID LIMIT	PLASTIC LIMIT	PLASTIC INDEX	SULFATE (WT %)	FHA SWELL (PSF)	SWELL/ COLLAPSE (%)	AASHTO CLASS. (GROUP INDEX)	USCS	SOIL DESCRIPTION
1, CBR	8	1-3	12.6		43.5	31	21	10				A-6 (1)	SC	SAND, CLAYEY
1	1	5	11.3		29.4	NV	NP	NP	0.00			A-2-4 (0)	SM	SAND, SILTY
1	2	2-3	17.5	93.2	45.2	32	24	8	<0.01		-1.8	A-4 (1)	SC	SAND, CLAYEY
1	3	10	10.9		39.8								SC	SAND, CLAYEY
1	5	5	14.7	103.4	46.5						-0.4		SC	SAND, CLAYEY
1	7	2-3	12.9	90.8	32.1						-0.4		SC	SAND, CLAYEY
1	8	1-2	14.5	102.3	35.6	28	21	7	<0.01		0.8	A-4 (0)	SC	SAND, CLAYEY
1	9	1-2	19.5	109.6	42.4	33	22	11			0.6	A-6 (1)	SC	SAND, CLAYEY
1	1	2-3	14.8	108.9							-0.1		SC	SAND, CLAYEY
2	4	5	11.7		54.9								CL	CLAY, SANDY
2	6	10	14.1		54.5					450			CL	CLAY, SANDY

TEST BORING 8  
 DEPTH (FT) 1-3

SOIL DESCRIPTION SAND, CLAYEY  
 SOIL TYPE 1, CBR

Sieve Analysis  
 Grain Size Distribution

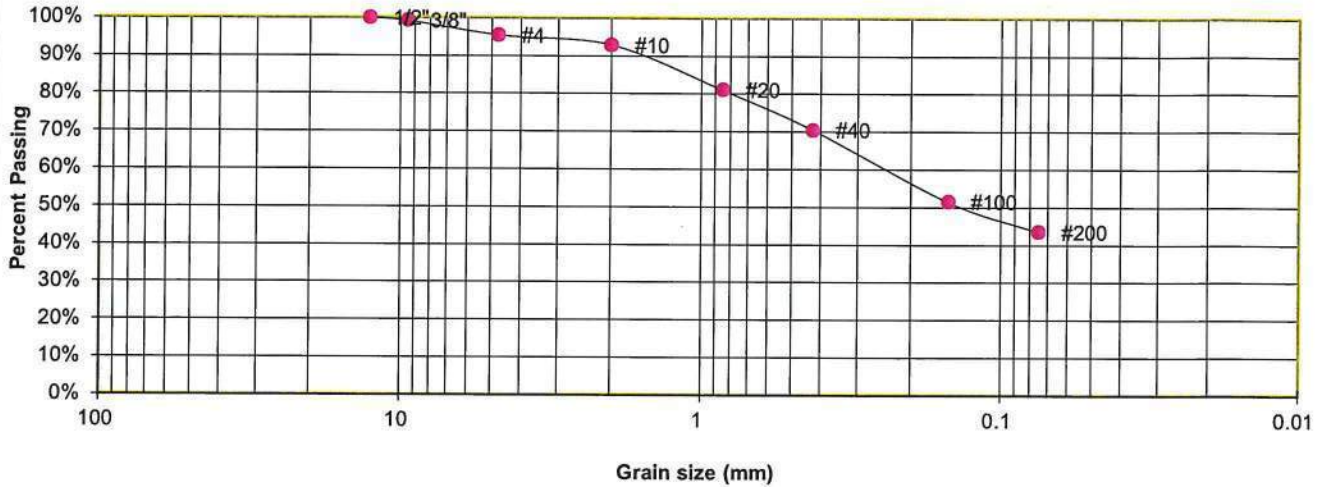

**GRAIN SIZE ANALYSIS**

U.S. Sieve #	Percent Finer
3"	
1 1/2"	
3/4"	
1/2"	100.0%
3/8"	99.3%
4	95.4%
10	92.8%
20	81.1%
40	70.5%
100	51.4%
200	43.5%

**ATTERBERG LIMITS**

Plastic Limit	21
Liquid Limit	31
Plastic Index	10

**SOIL CLASSIFICATION**

USCS CLASSIFICATION:	SC
AASHTO CLASSIFICATION:	A-6
AASHTO GROUP INDEX:	1



LABORATORY TEST RESULTS

2725 AKERS DRIVE  
 BUCHER DESIGN STUDIO

JOB NO.  
 242065

FIG. B-1



TEST BORING 1  
 DEPTH (FT) 5

SOIL DESCRIPTION SAND, SILTY  
 SOIL TYPE 1

**Sieve Analysis  
 Grain Size Distribution**

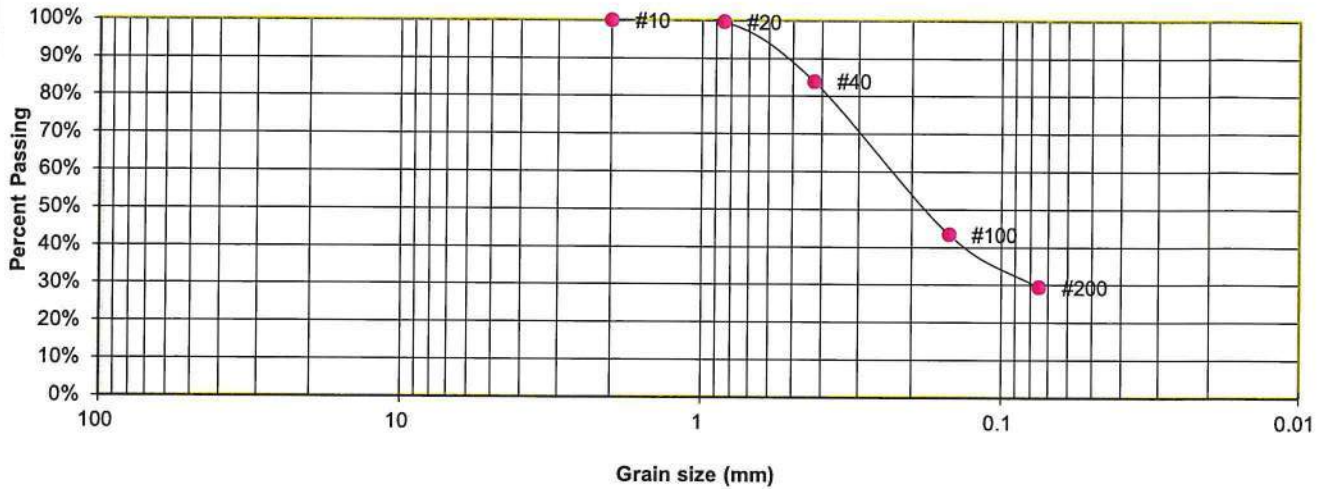

**GRAIN SIZE ANALYSIS**

U.S. Sieve #	Percent Finer
3"	
1 1/2"	
3/4"	
1/2"	
3/8"	
4	
10	100.0%
20	99.6%
40	83.9%
100	43.4%
200	29.4%

**ATTERBERG LIMITS**

Plastic Limit	NP
Liquid Limit	NV
Plastic Index	NP

**SOIL CLASSIFICATION**

USCS CLASSIFICATION: SM  
 AASHTO CLASSIFICATION: A-2-4  
 AASHTO GROUP INDEX: 0



**LABORATORY TEST RESULTS**

2725 AKERS DRIVE  
 BUCHER DESIGN STUDIO

JOB NO.  
 242065

**FIG. B-2**

TEST BORING 2  
 DEPTH (FT) 2-3

SOIL DESCRIPTION SAND, CLAYEY  
 SOIL TYPE 1

Sieve Analysis  
 Grain Size Distribution

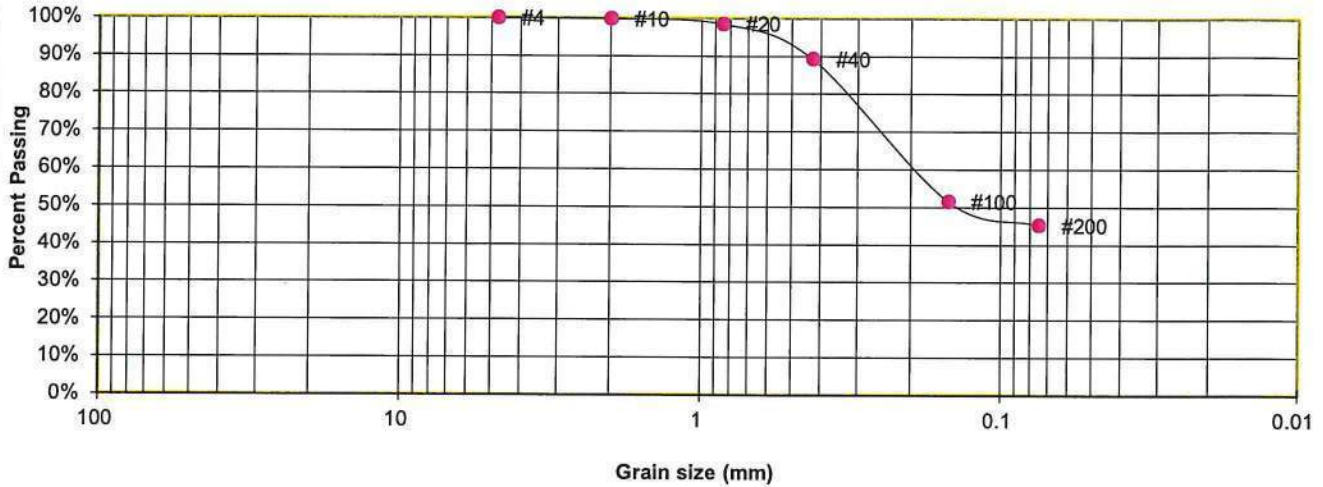

**GRAIN SIZE ANALYSIS**

U.S. Sieve #	Percent Finer
3"	
1 1/2"	
3/4"	
1/2"	
3/8"	
4	100.0%
10	99.9%
20	98.5%
40	89.2%
100	51.6%
200	45.2%

**ATTERBERG LIMITS**

Plastic Limit	24
Liquid Limit	32
Plastic Index	8

**SOIL CLASSIFICATION**

USCS CLASSIFICATION:	SC
AASHTO CLASSIFICATION:	A-4
AASHTO GROUP INDEX:	1



LABORATORY TEST RESULTS

2725 AKERS DRIVE  
 BUCHER DESIGN STUDIO

JOB NO.  
 242065

FIG. B-3

TEST BORING 3  
DEPTH (FT) 10

SOIL DESCRIPTION SAND, CLAYEY  
SOIL TYPE 1

### Sieve Analysis Grain Size Distribution

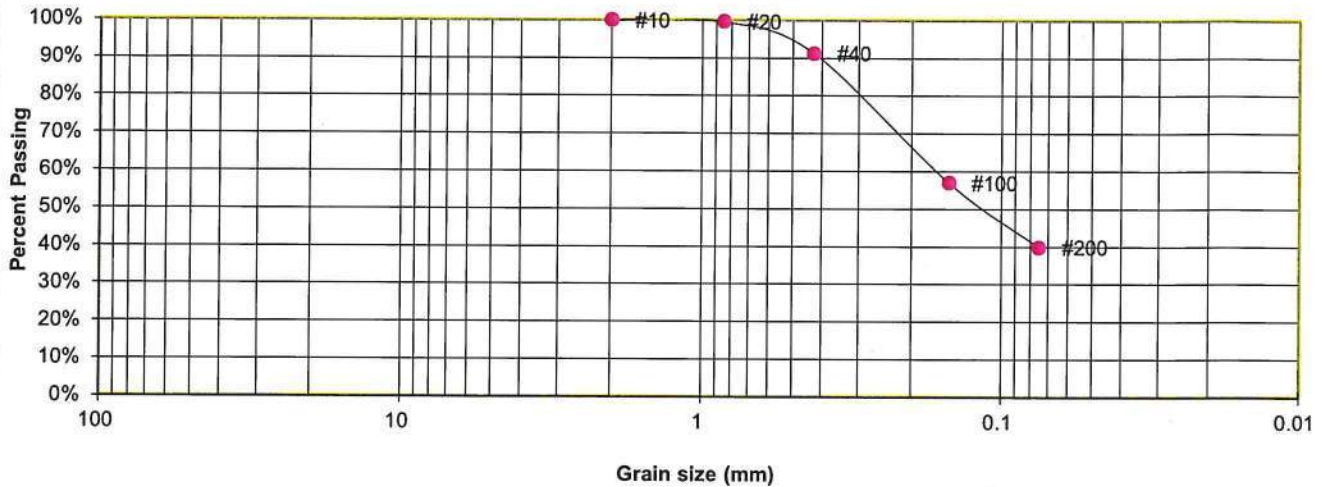

#### GRAIN SIZE ANALYSIS

U.S. Sieve #	Percent Finer
3"	
1 1/2"	
3/4"	
1/2"	
3/8"	
4	
10	100.0%
20	99.6%
40	91.2%
100	57.0%
200	39.8%

#### SOIL CLASSIFICATION

USCS CLASSIFICATION: SC  
AASHTO CLASSIFICATION:  
AASHTO GROUP INDEX:



### LABORATORY TEST RESULTS

2725 AKERS DRIVE  
BUCHER DESIGN STUDIO

JOB NO.  
242065

FIG. B-4

TEST BORING 5  
DEPTH (FT) 5

SOIL DESCRIPTION SAND, CLAYEY  
SOIL TYPE 1

### Sieve Analysis Grain Size Distribution

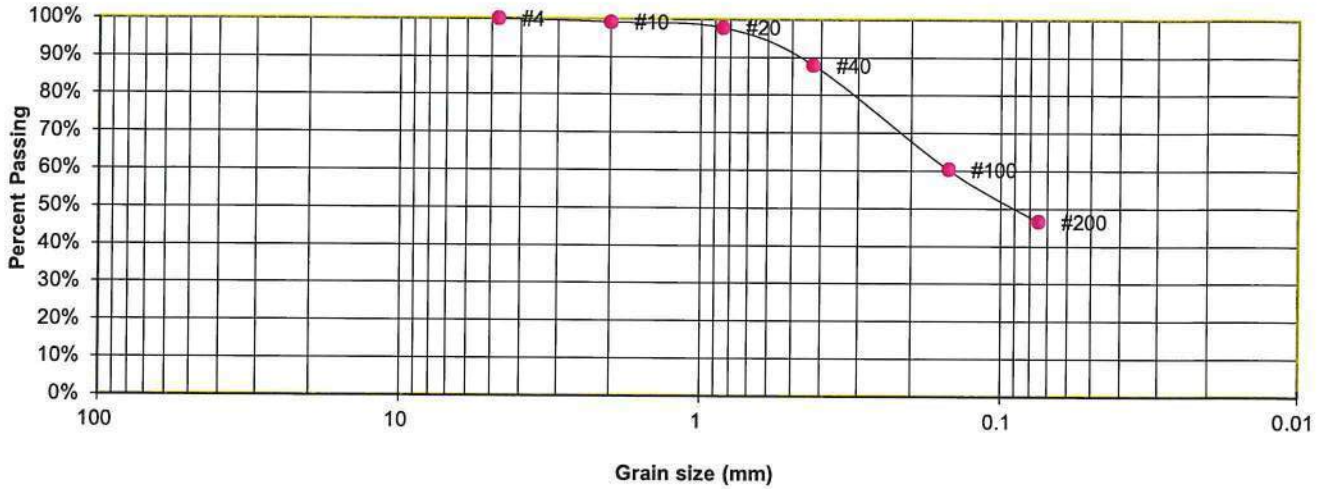

#### GRAIN SIZE ANALYSIS

U.S. Sieve #	Percent Finer
3"	
1 1/2"	
3/4"	
1/2"	
3/8"	
4	100.0%
10	99.2%
20	97.8%
40	87.9%
100	60.3%
200	46.5%

#### SOIL CLASSIFICATION

USCS CLASSIFICATION: SC  
AASHTO CLASSIFICATION:  
AASHTO GROUP INDEX:



### LABORATORY TEST RESULTS

2725 AKERS DRIVE  
BUCHER DESIGN STUDIO

JOB NO.  
242065

FIG. B-5



TEST BORING 7  
DEPTH (FT) 2-3

SOIL DESCRIPTION SAND, CLAYEY  
SOIL TYPE 1

Sieve Analysis  
Grain Size Distribution

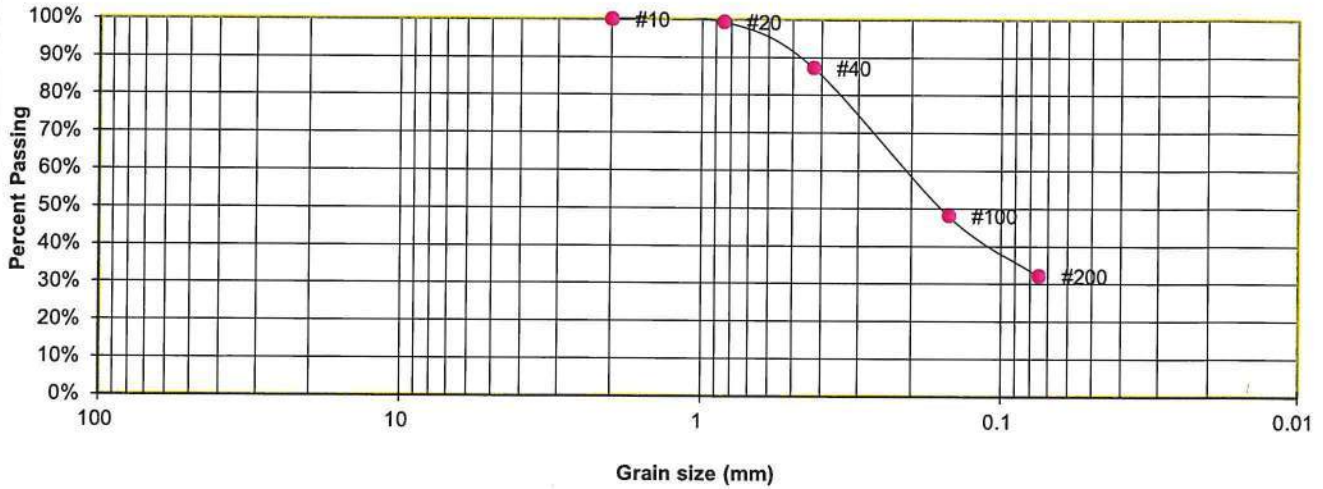

**GRAIN SIZE ANALYSIS**

U.S. Sieve #	Percent Finer
3"	
1 1/2"	
3/4"	
1/2"	
3/8"	
4	
10	100.0%
20	99.3%
40	87.2%
100	48.1%
200	32.1%

**SOIL CLASSIFICATION**

USCS CLASSIFICATION: SC  
AASHTO CLASSIFICATION:  
AASHTO GROUP INDEX:



LABORATORY TEST RESULTS

2725 AKERS DRIVE  
BUCHER DESIGN STUDIO

JOB NO.  
242065

FIG. B-6

TEST BORING 8  
 DEPTH (FT) 1-2

SOIL DESCRIPTION SAND, CLAYEY  
 SOIL TYPE 1

Sieve Analysis  
 Grain Size Distribution

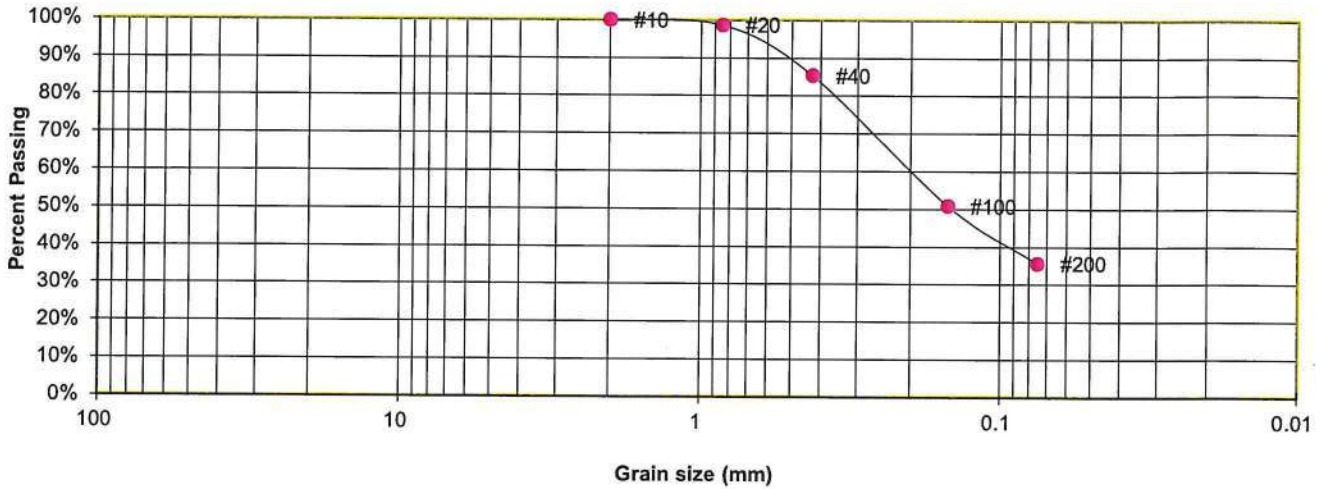

**GRAIN SIZE ANALYSIS**

U.S. Sieve #	Percent Finer
3"	
1 1/2"	
3/4"	
1/2"	
3/8"	
4	
10	100.0%
20	98.7%
40	85.3%
100	50.9%
200	35.6%

**ATTERBERG LIMITS**

Plastic Limit	21
Liquid Limit	28
Plastic Index	7

**SOIL CLASSIFICATION**

USCS CLASSIFICATION:	SC
AASHTO CLASSIFICATION:	A-4
AASHTO GROUP INDEX:	0



**LABORATORY TEST RESULTS**

2725 AKERS DRIVE  
 BUCHER DESIGN STUDIO

JOB NO.  
 242065

**FIG. B-7**

TEST BORING 9  
 DEPTH (FT) 1-2

SOIL DESCRIPTION SAND, CLAYEY  
 SOIL TYPE 1

**Sieve Analysis  
 Grain Size Distribution**

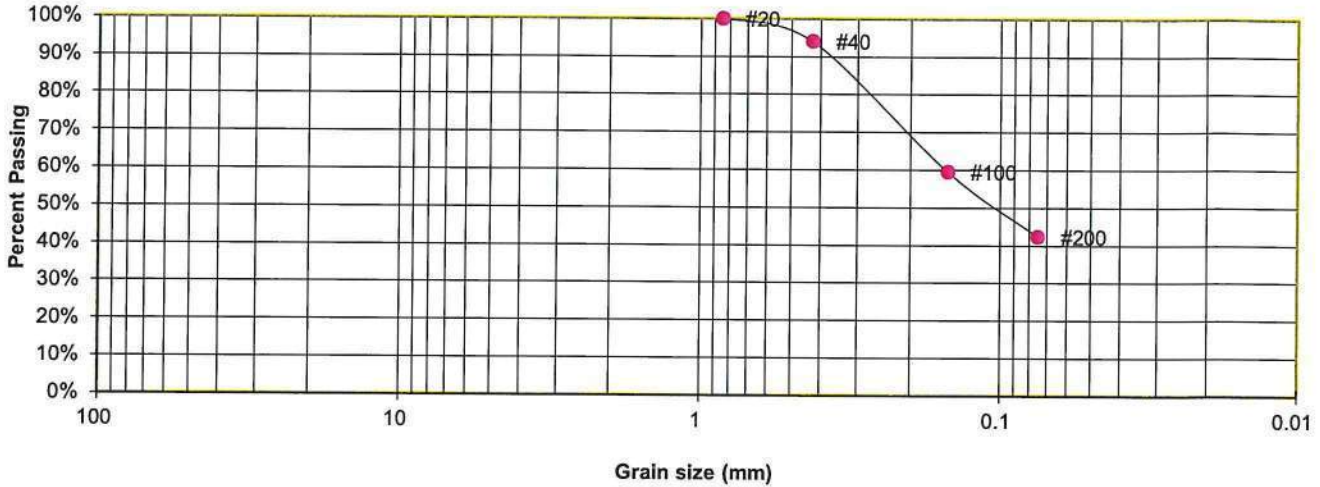

**GRAIN SIZE ANALYSIS**

U.S. Sieve #	Percent Finer
3"	
1 1/2"	
3/4"	
1/2"	
3/8"	
4	
10	
20	100.0%
40	93.9%
100	59.5%
200	42.4%

**ATTERBERG LIMITS**

Plastic Limit	22
Liquid Limit	33
Plastic Index	11

**SOIL CLASSIFICATION**

USCS CLASSIFICATION:	SC
AASHTO CLASSIFICATION:	A-6
AASHTO GROUP INDEX:	1



**LABORATORY TEST RESULTS**

2725 AKERS DRIVE  
 BUCHER DESIGN STUDIO

JOB NO.  
 242065

**FIG. B-8**

TEST BORING 4  
DEPTH (FT) 5

SOIL DESCRIPTION CLAY, SANDY  
SOIL TYPE 2

Sieve Analysis  
Grain Size Distribution

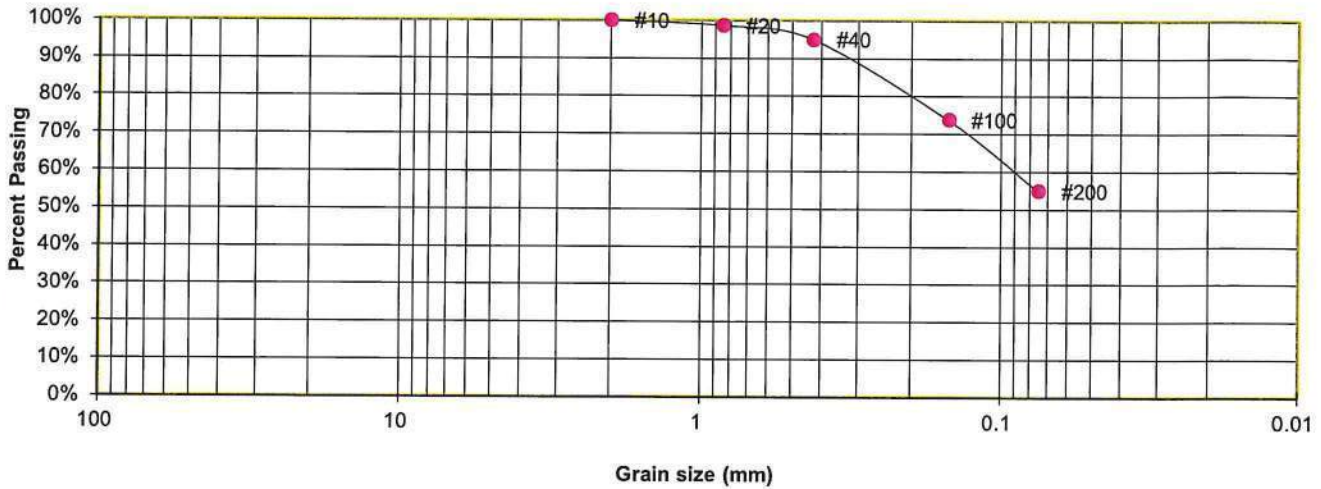

**GRAIN SIZE ANALYSIS**

U.S. Sieve #	Percent Finer
3"	
1 1/2"	
3/4"	
1/2"	
3/8"	
4	
10	100.0%
20	98.7%
40	94.9%
100	73.7%
200	54.9%

**SOIL CLASSIFICATION**

USCS CLASSIFICATION: CL  
AASHTO CLASSIFICATION:  
AASHTO GROUP INDEX:



LABORATORY TEST RESULTS

2725 AKERS DRIVE  
BUCHER DESIGN STUDIO

JOB NO.  
242065

FIG. B-9



TEST BORING 6  
 DEPTH (FT) 10

SOIL DESCRIPTION CLAY, SANDY  
 SOIL TYPE 2

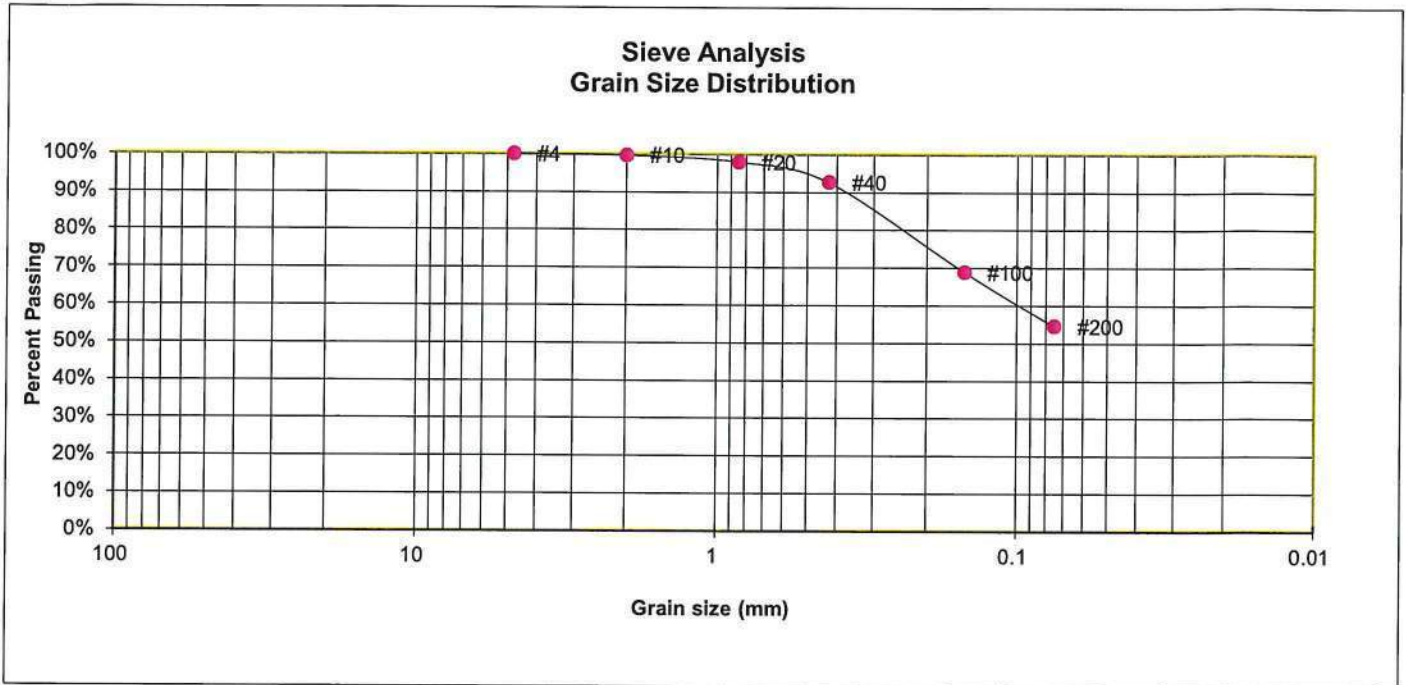

**GRAIN SIZE ANALYSIS**

U.S. Sieve #	Percent Finer
3"	
1 1/2"	
3/4"	
1/2"	
3/8"	
4	100.0%
10	99.7%
20	98.0%
40	92.6%
100	68.9%
200	54.5%

**FHA SWELL**

Moisture at start	12.3%
Moisture at finish	24.9%
Moisture increase	12.6%
Initial dry density (pcf)	95
Swell (psf)	450

**SOIL CLASSIFICATION**

USCS CLASSIFICATION: CL  
 AASHTO CLASSIFICATION:  
 AASHTO GROUP INDEX:



**LABORATORY TEST RESULTS**

2725 AKERS DRIVE  
 BUCHER DESIGN STUDIO

JOB NO.  
 242065

**FIG. B-10**

TEST BORING 1  
DEPTH (FT) 2-3

SOIL DESCRIPTION SAND, CLAYEY  
SOIL TYPE 1

### SWELL CONSOLIDATION

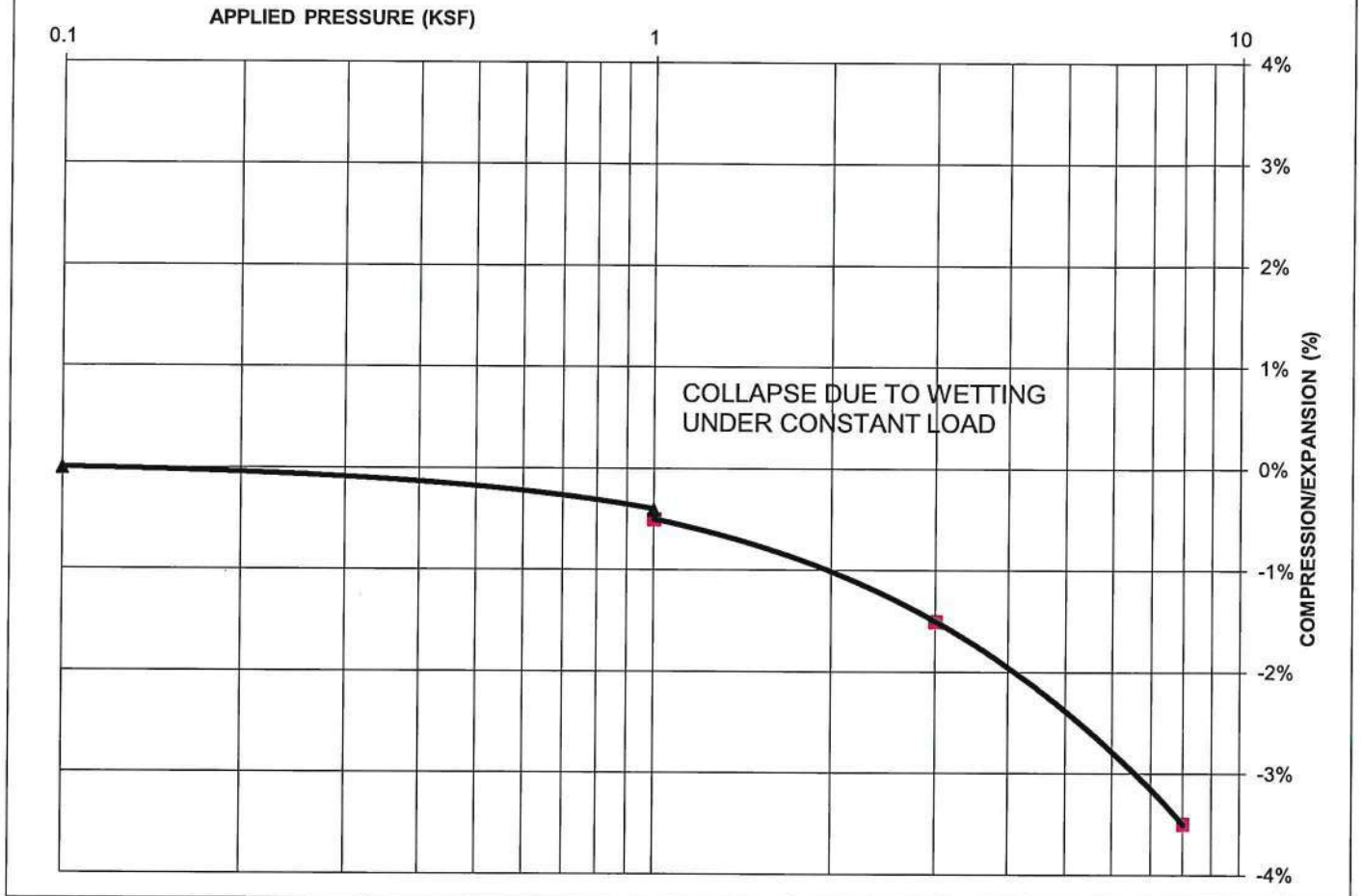

#### SWELL/COLLAPSE TEST RESULTS

NATURAL UNIT DRY WEIGHT (PCF): 109  
NATURAL MOISTURE CONTENT: 14.8%  
SWELL/COLLAPSE (%): -0.1%



### SWELL TEST RESULTS

2725 AKERS DRIVE  
BUCHER DESIGN STUDIO

JOB NO.  
242065

FIG. B-11

TEST BORING 2  
DEPTH (FT) 2-3

SOIL DESCRIPTION SAND, CLAYEY  
SOIL TYPE 1

### SWELL CONSOLIDATION

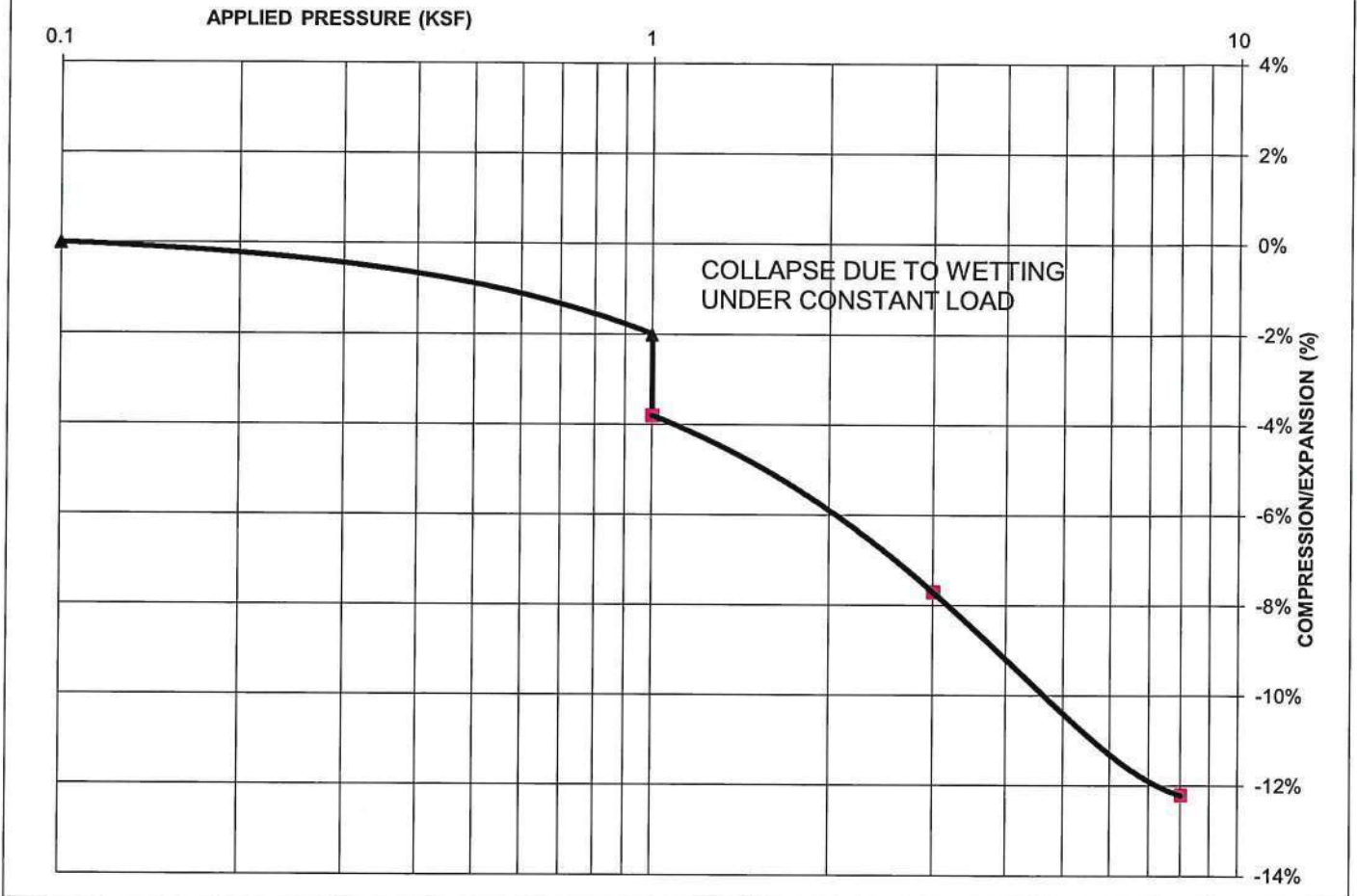

#### SWELL/COLLAPSE TEST RESULTS

NATURAL UNIT DRY WEIGHT (PCF): 93  
NATURAL MOISTURE CONTENT: 17.5%  
SWELL/COLLAPSE (%): -1.8%



### SWELL TEST RESULTS

2725 AKERS DRIVE  
BUCHER DESIGN STUDIO

JOB NO.  
242065

FIG. B-12

TEST BORING 5  
DEPTH (FT) 5

SOIL DESCRIPTION SAND, CLAYEY  
SOIL TYPE 1

### SWELL CONSOLIDATION

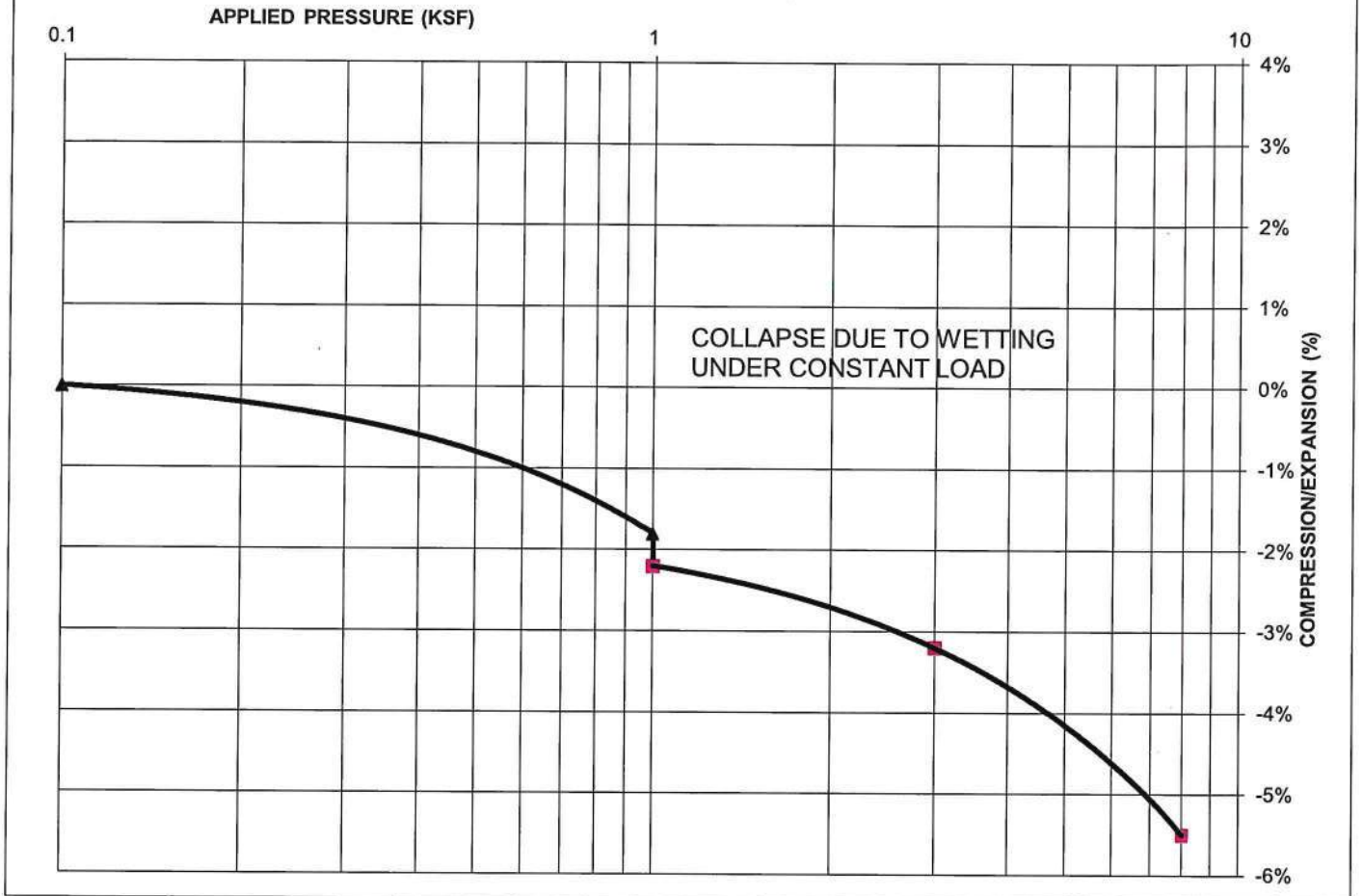

#### SWELL/COLLAPSE TEST RESULTS

NATURAL UNIT DRY WEIGHT (PCF): 103  
NATURAL MOISTURE CONTENT: 14.7%  
SWELL/COLLAPSE (%): -0.4%



### SWELL TEST RESULTS

2725 AKERS DRIVE  
BUCHER DESIGN STUDIO

JOB NO.  
242065

FIG. B-13



TEST BORING 7  
DEPTH (FT) 2-3

SOIL DESCRIPTION SAND, CLAYEY  
SOIL TYPE 1

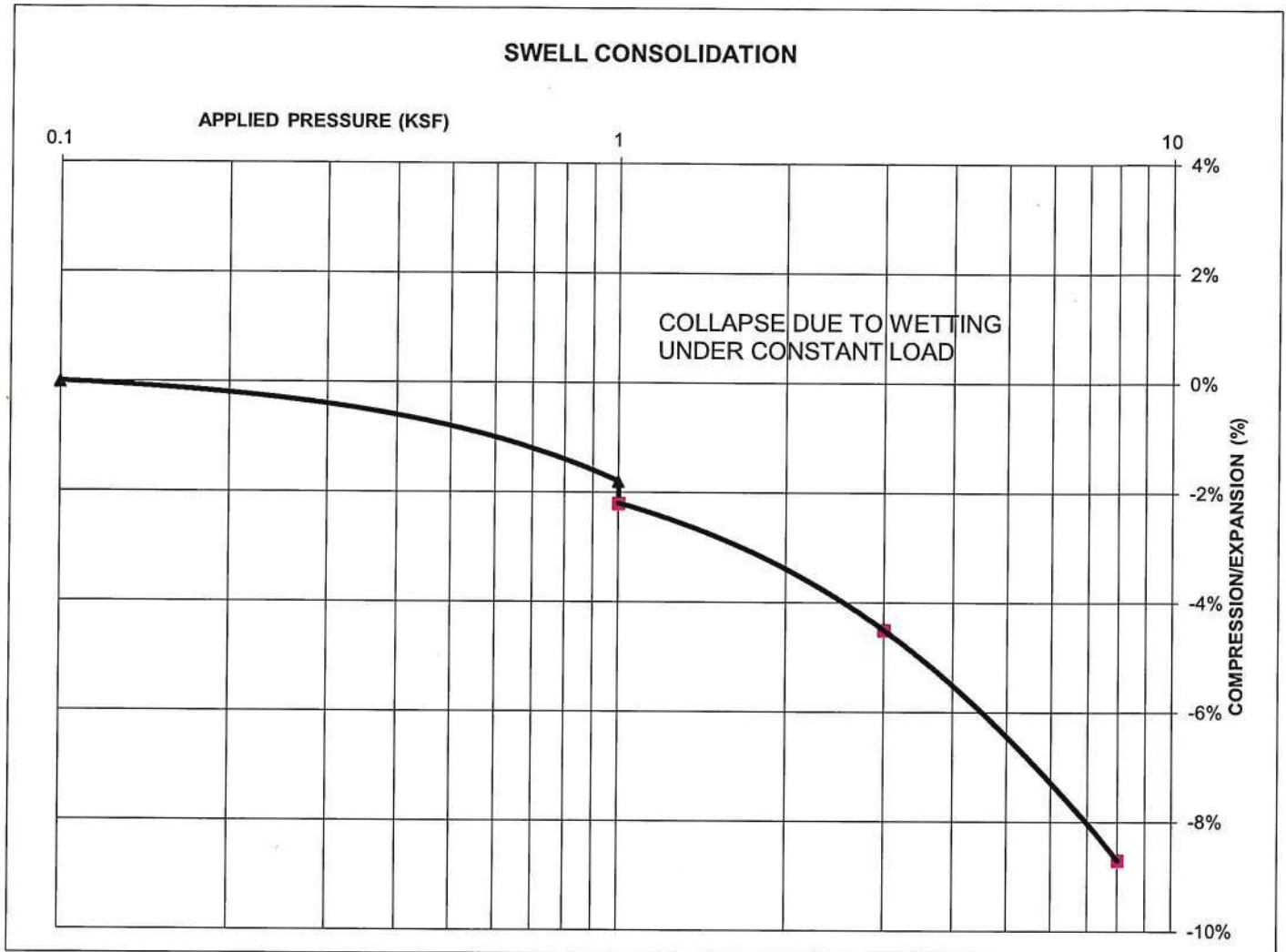

**SWELL/COLLAPSE TEST RESULTS**

NATURAL UNIT DRY WEIGHT (PCF): 91  
NATURAL MOISTURE CONTENT: 12.9%  
SWELL/COLLAPSE (%): -0.4%



**SWELL TEST RESULTS**

2725 AKERS DRIVE  
BUCHER DESIGN STUDIO

JOB NO.  
242065

**FIG. B-14**

TEST BORING 8  
DEPTH (FT) 1-2

SOIL DESCRIPTION SAND, CLAYEY  
SOIL TYPE 1

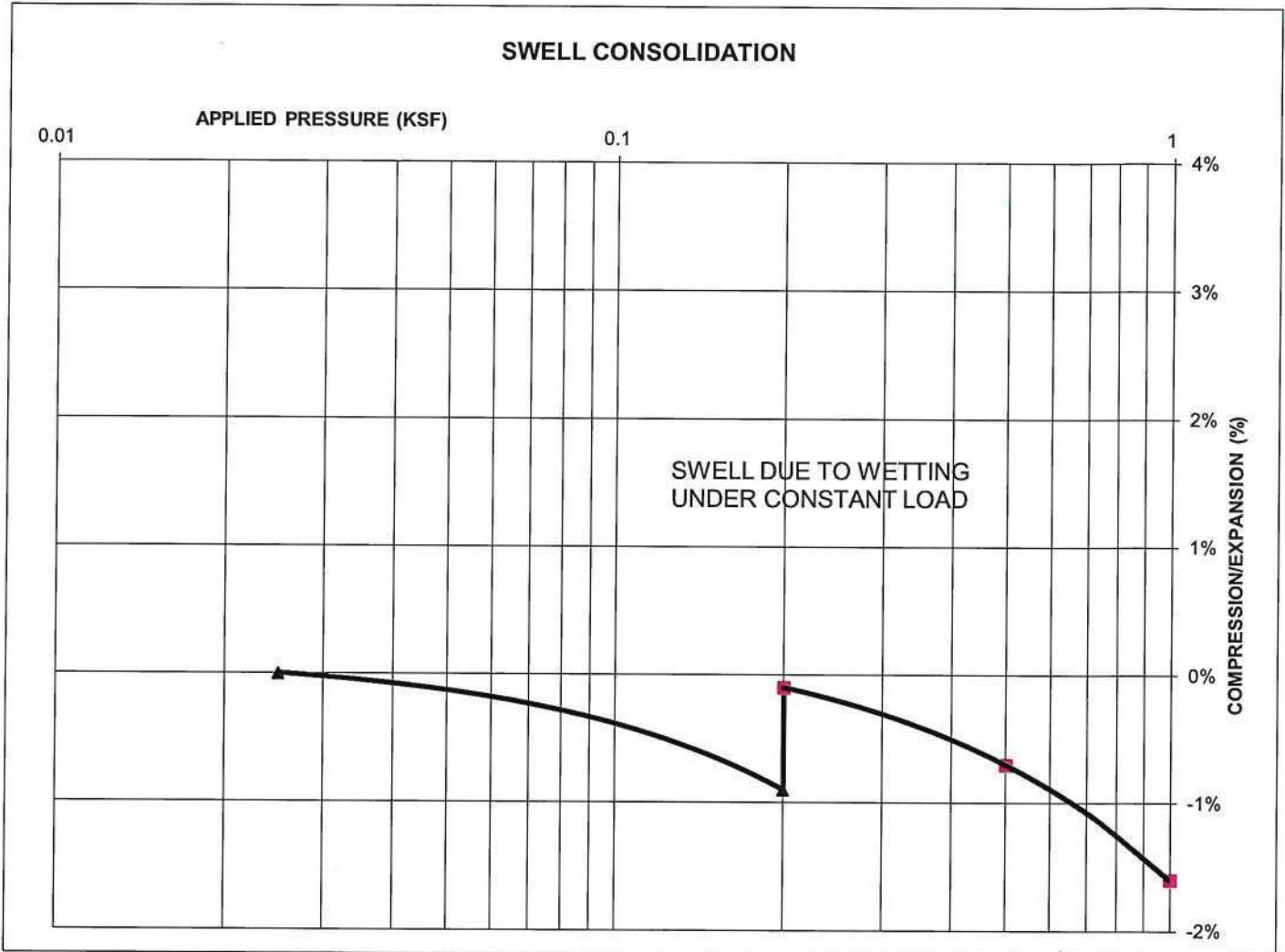

**SWELL/COLLAPSE TEST RESULTS**

NATURAL UNIT DRY WEIGHT (PCF): 102  
NATURAL MOISTURE CONTENT: 14.5%  
SWELL/COLLAPSE (%): 0.8%



**SWELL TEST RESULTS**

2725 AKERS DRIVE  
BUCHER DESIGN STUDIO

JOB NO.  
242065

**FIG. B-15**

TEST BORING 9  
DEPTH (FT) 1-2

SOIL DESCRIPTION SAND, CLAYEY  
SOIL TYPE 1

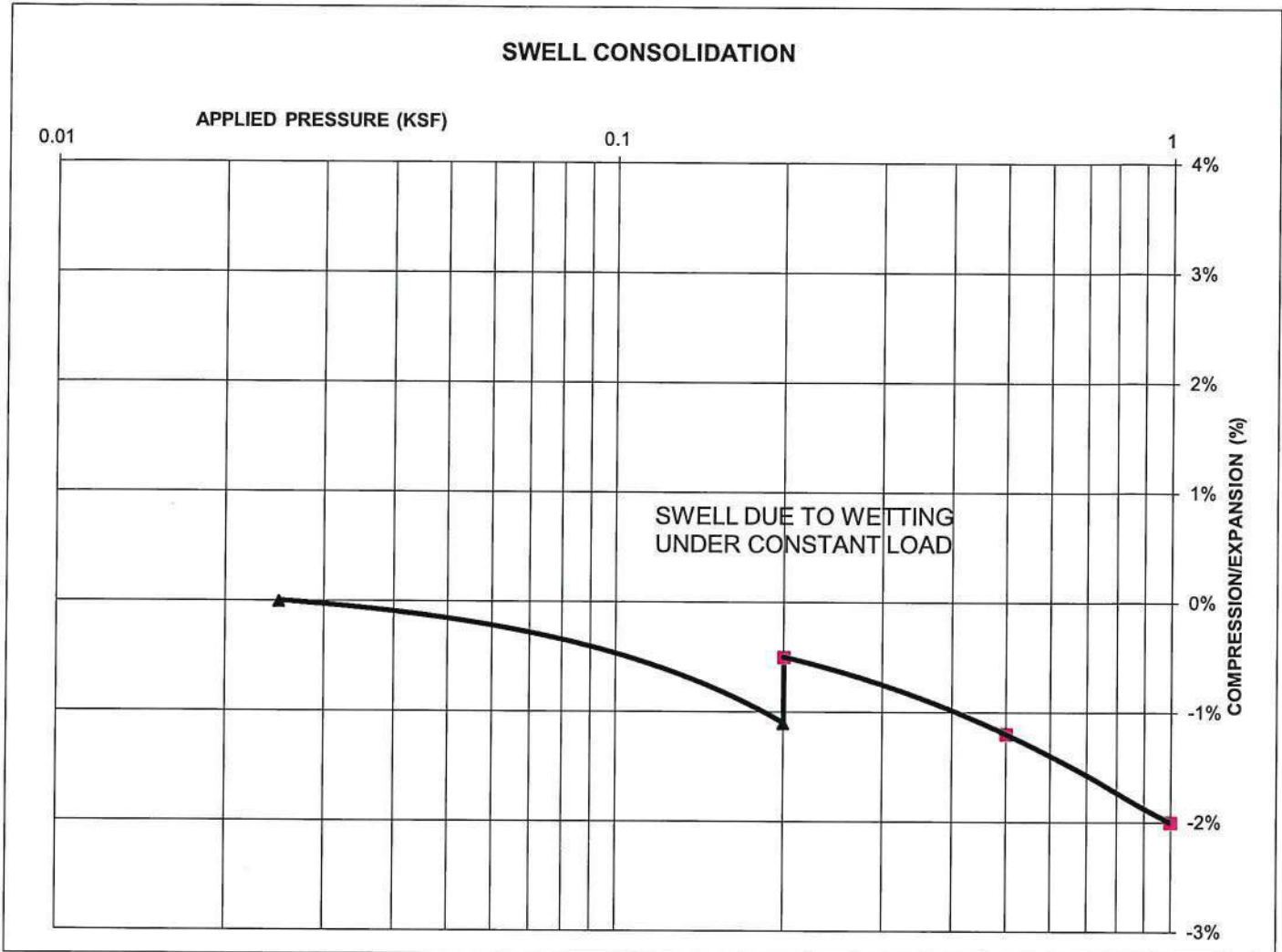

**SWELL/COLLAPSE TEST RESULTS**

NATURAL UNIT DRY WEIGHT (PCF): 110  
NATURAL MOISTURE CONTENT: 19.5%  
SWELL/COLLAPSE (%): 0.6%



**SWELL TEST RESULTS**

2725 AKERS DRIVE  
BUCHER DESIGN STUDIO

JOB NO.  
242065

**FIG. B-16**



SAMPLE LOCATION TB-8 @ 1-3'

SOIL DESCRIPTION SAND, CLAYEY, BLACK  
SOIL TYPE 1

**PROCTOR DATA**

IDENTIFICATION: SC  
PROCTOR TEST #: 1  
TEST BY: PH  
TEST DESIGNATION: ASTM-698-A  
MAXIMUM DRY DENSITY (PCF): 104.8  
OPTIMUM MOISTURE: 13.7

Compaction Curve

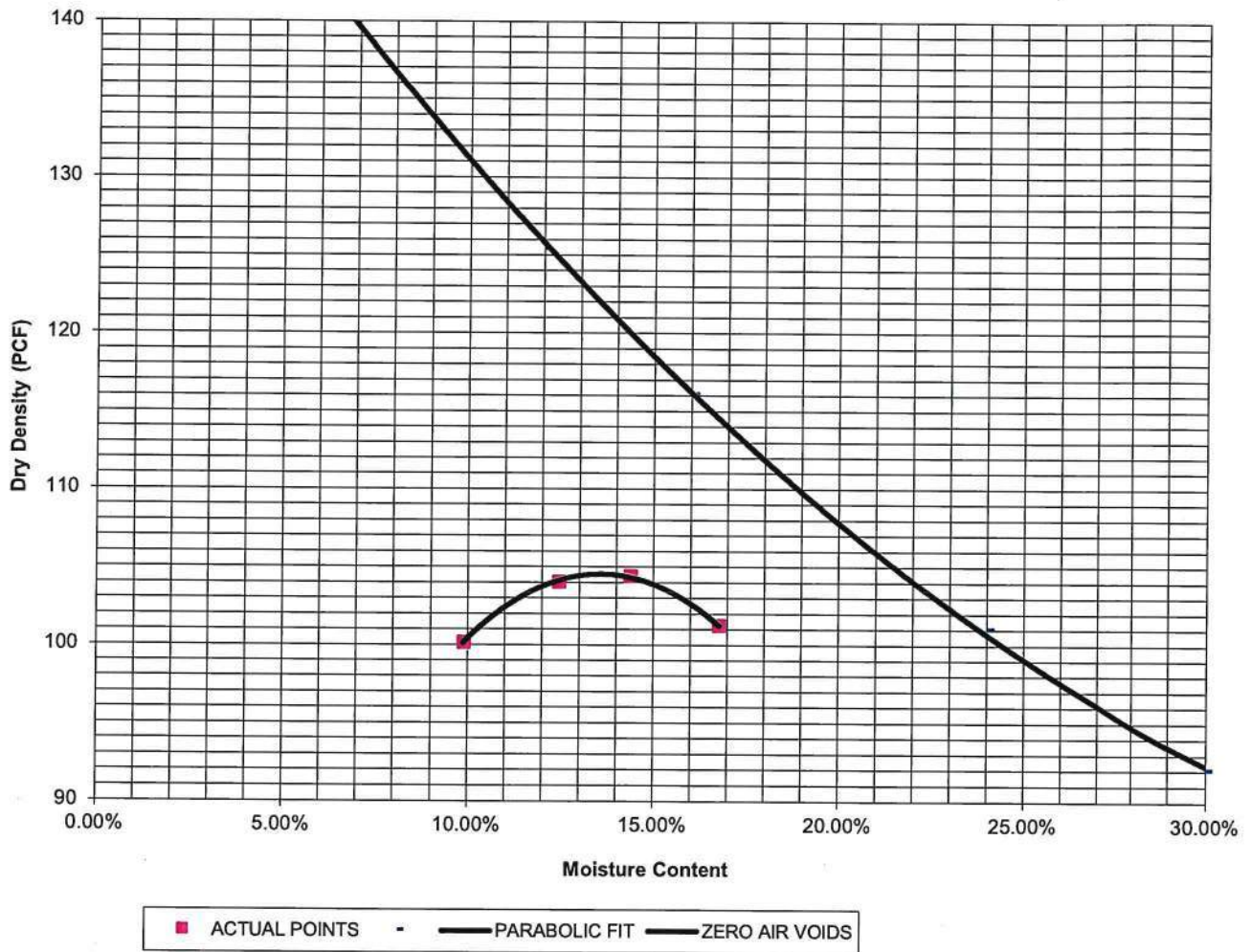

LABORATORY TEST RESULTS

2725 AKERS DRIVE  
BUCHER DESIGN STUDIO

JOB NO.  
242065

FIG. B-17

SAMPLE LOCATION TB-8 @ 1-3'

SOIL DESCRIPTION SAND, CLAYEY, BLACK  
SOIL TYPE 1

**CBR TEST LOAD DATA**

Piston Diameter (cm): 4.958

Piston Area (in<sup>2</sup>): 2.993

Penetration Depth (inches)	10 BLOWS Mold # 1		25 BLOWS Mold # 2		56 BLOWS Mold # 3	
	Load (lbs)	Stress (psi)	Load (lbs)	Stress (psi)	Load (lbs)	Stress (psi)
0.000	0	0.00	0	0.00	0	0.00
0.025	49	16.37	99	33.08	171	57.14
0.050	63	21.05	126	42.11	267	89.22
0.075	75	25.06	149	49.79	339	113.28
0.100	81	27.07	161	53.80	395	132.00
0.125	91	30.41	182	60.82	453	151.38
0.150	103	34.42	206	68.84	507	169.42
0.175	113	37.76	226	75.52	542	181.12
0.200	118	39.43	236	78.86	580	193.82
0.300	133	44.44	266	88.89	721	240.93
0.400	155	51.80	310	103.59	817	273.02
0.500	176	58.81	352	117.63	920	307.43

**MOISTURE AND DENSITY DATA**

	Mold # 1	Mold # 2	Mold # 3
Can #	300	352	361
Wt. Can	8	8.16	8.58
Wt. Can+Wet	150	163.03	162.66
Wt. Can+Dry	130	133.86	139.89
Wt. H2O	20	29.17	22.77
Wt. Dry Soil	122	125.7	131.31
Moisture Content	16.39%	23.21%	17.34%
Wet Density (PCF)	108.7	114.6	119.3
Dry Density (PCF)	95.6	100.8	105.0
% Compaction	91%	96%	100%
CBR	2.71	5.38	13.20

**PROCTOR DATA**

Maximum Dry Density (pcf)	104.8
Optimum Moisture	13.7
90% of Max. Dry Density (pcf)	94.3
95% of Max. Dry Density (pcf)	99.6

CBR at 90% of Max. Density = 2.0 ~ R VALUE 6  
CBR at 95% of Max. Density = 4.7 ~ R VALUE 10



**LABORATORY TEST RESULTS**

2725 AKERS DRIVE  
BUCHER DESIGN STUDIO

JOB NO.  
242065

**FIG. B-18**

SAMPLE LOCATION TB-8 @ 1-3'

SOIL DESCRIPTION SAND, CLAYEY, BLACK  
SOIL TYPE 1

Stress VS Penetration

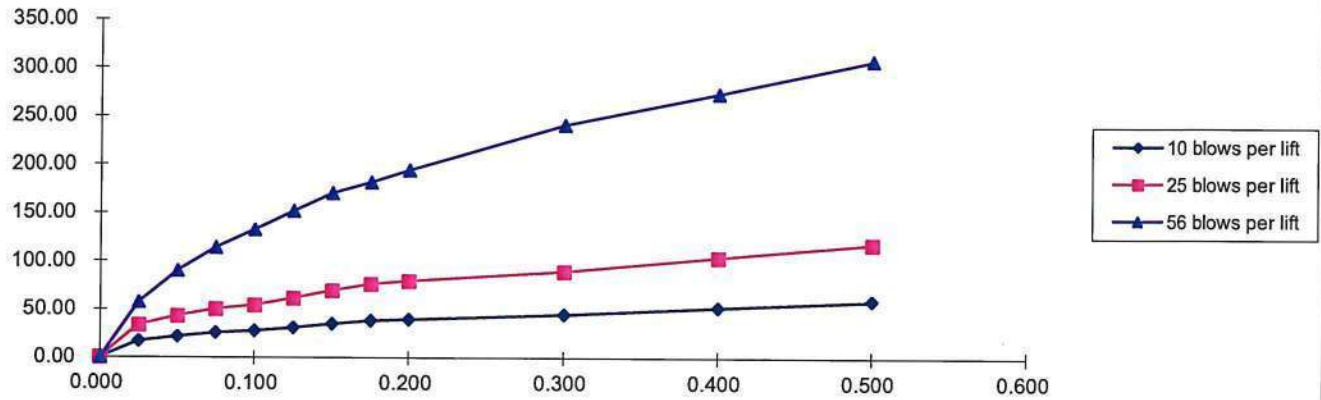

Bearing Ratio VS Dry Density

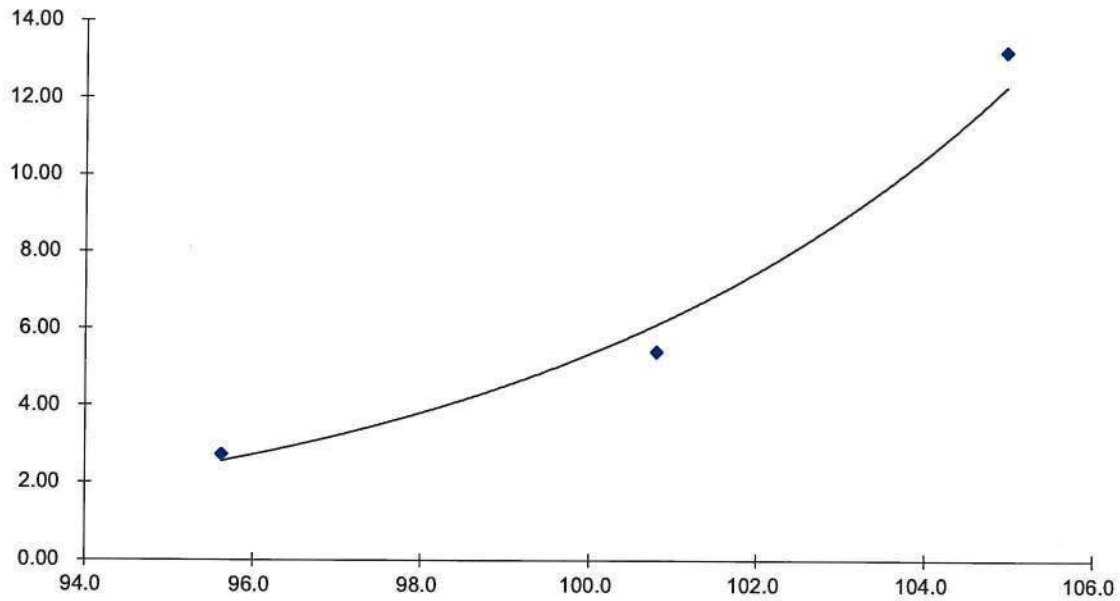

LABORATORY TEST RESULTS

2725 AKERS DRIVE  
BUCHER DESIGN STUDIO

JOB NO.  
242065

FIG. B-19



## **APPENDIX C: Pavement Design Calculations**



## FLEXIBLE PAVEMENT DESIGN

### PROJECT DATA

Project Location: 2725 Akers Drive - Addition and Retaining Walls  
 Job Number: 242065

### DESIGN DATA

Equivalent (18-kip) Single Axle Load Applications (ESAL):	ESAL ( $W_{18}$ ) =	50,000
Design CBR	CBR =	4.7
Standard Deviation	$S_o$ =	0.44
Loss in Serviceability	$\Delta\psi$ =	2.5
Reliability	Reliability =	85
Reliability (z-statistic)	$Z_R$ =	-1.04
Soil Resilient Modulus	$M_R$ =	7,050 psi

Required Structural Number (SN): ➔ SN = 2.03

### DESIGN EQUATIONS

#### Resilient Modulus

If using CBR:

$$M_R = (\text{CBR}) \times 1,500$$

If using R-Value:

$$M_R = 10^{[(S_1 + 18.72) / 6.24]} \text{ where: } S_1 = [(R\text{-value} - 5) / 11.29] + 3$$

#### Required Structural Number

$$\log_{10} W_{18} = Z_R \cdot S_o + 9.36 \cdot \log_{10} (SN+1) - 0.20 + \frac{\log_{10} \left[ \frac{\Delta \text{PSI}}{4.2 - 1.5} \right]}{0.40 + \frac{1094}{(SN+1)^{5.19}}} + 2.32 \cdot \log_{10} M_R - 8.07$$

#### Pavement Section Thickness

$SN^* = C_1 D_1 + C_2 D_2$  where:

- $C_1$  = Strength Coefficient - HMA
- $C_2$  = Strength Coefficient - ABC/RCB
- $D_1$  = Depth of HMA (inches)
- $D_2$  = Depth of ABC/RCB (inches)

### RECOMMENDED THICKNESSES

Layer	Material	Structural Layer	Thickness ( $D^*_i$ )	$SN^*_i$	SN
1	HMA	$C_1 = 0.44$	4.0 inches	1.760	-
2	ABC/RCB	$C_2 = 0.12$	4.0 inches	0.480	
				<b>SN* = 2.240</b>	<b>2.03</b>

Pavement SN > Required SN, Design is Acceptable

FIG. C-1



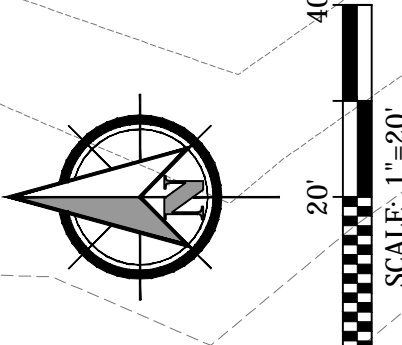

Grading Legend	
EX G	Gas Line (Underground)
EX UOE	Electric Line (Underground)
EX T	Telephone Line (Underground)
+	Accessible Route
▬	Concrete Sidewalk
▬	Concrete Gutter/Pan
+	Asphalt Mill & Overlay
16.04	Spot Elevation Existing or Proposed
3.0%	Flow Direction Arrow/Slope Existing or Proposed
+(H.P.)	Flow Direction Arrow/Slope Existing or Proposed
---	Limits Of Disturbance Construction Site Boundary
---	Existing Index Contour
---	Proposed Index Contour
---	Proposed Inter. Contour
---	Property Line
---	Proposed Ditch Flowline
---	Proposed 4" PVC Sleeve (Water Quality)
---	Proposed Curb Type Designation

Erosion Control Legend	
SF	Silt Fence or Sediment Control Log
CF	Construction Fence
RS	Rock Sock
IP-1	Inlet Protection
CWA	Concrete Washout Area*
SSA	Stabilized Staging Area*
PT	Portable Toilet*
SP	Stock Pile Management*
VTC	Vehicle Tracking (Feet/Alternate)

\* To Be Determined By The Contractor

El Paso County (hereinafter "EPC") has reviewed this Stormwater Management Plan for general conformance with County Design Criteria. The County is not responsible for the accuracy and adequacy of the design, dimensions, and/or other information contained in this document. The user of this document assumes no responsibility for completeness and/or accuracy of this document. Filed in accordance with the requirements of the El Paso County Land Development Code, Drainage Criteria Manual Sections 1- and 2, and Engineering Criteria Manual, as amended.

In accordance with EPC Section 1-12, these construction documents will be void for approval, including payment of review fees of the Planning and Community Development Director's discretion.

County Engineer/ECM Administrator  
Joshua Palmer, P.E.

County Engineer/ECM Administrator  
Andrew W. McCord, P.E. 24057

Engineer's Statement (for standalone EEC Plan):  
I, the undersigned, have read and will comply with the requirements of the Grading and Erosion Control Plan.

Owner's Statement (for standalone EEC Plan):  
I, the undersigned, have read and will comply with the requirements of the Grading and Erosion Control Plan.

Engineer's Statement (for standalone EEC Plan):  
I, the undersigned, have read and will comply with the requirements of the Grading and Erosion Control Plan.

Owner's Statement (for standalone EEC Plan):  
I, the undersigned, have read and will comply with the requirements of the Grading and Erosion Control Plan.

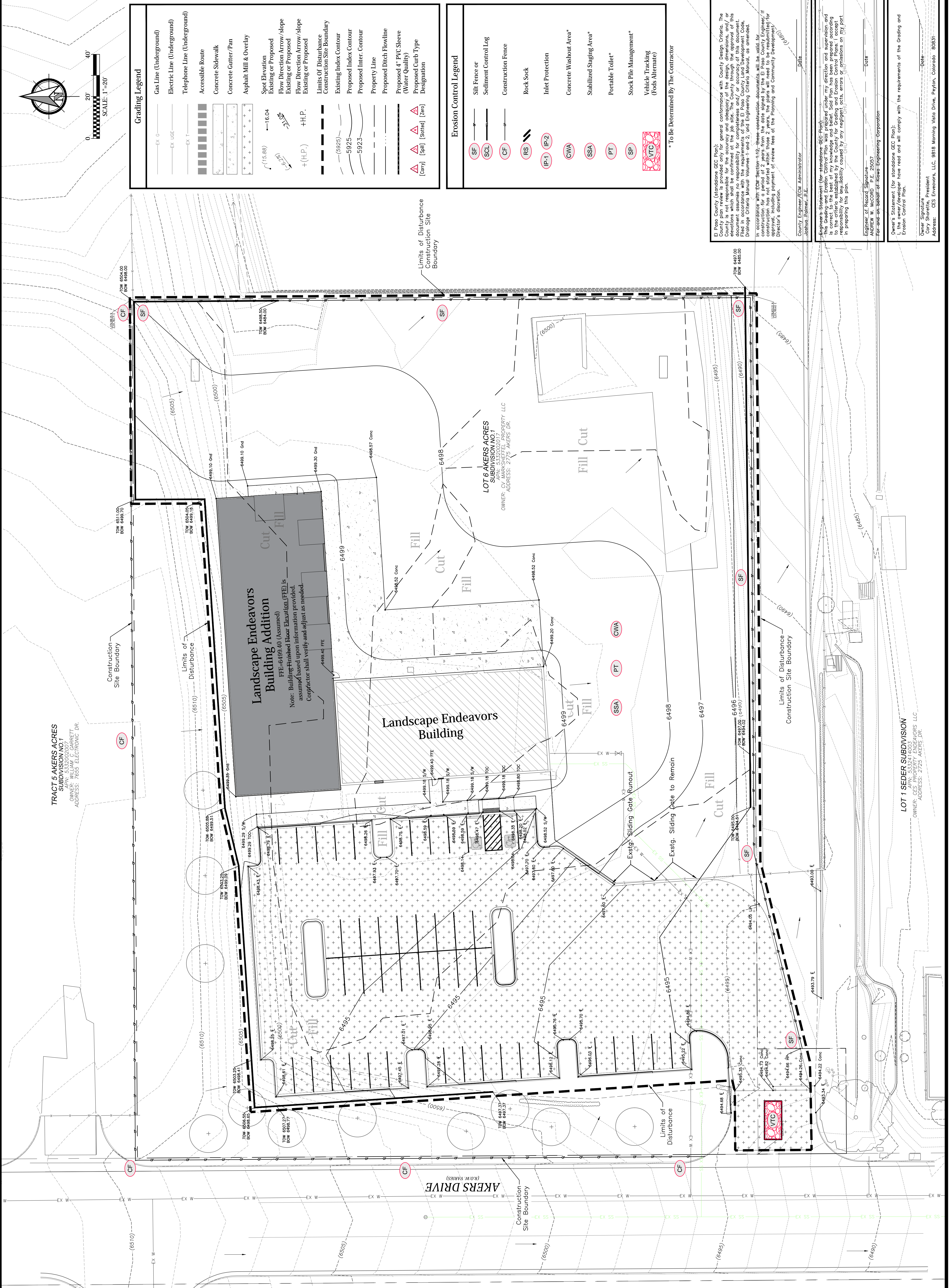



# Landscape Endeavors Building Addition

## Grading and Erosion Control - Cover Sheet

### Prepared for CES Enveavors, LLC

#### PROJECT SPECIFIC GRADING AND EROSION CONTROL NOTES

- Stormwater discharges from construction sites shall not cause or threaten to cause pollution, contamination, or nuisance. Erosion control measures shall be installed in a manner that minimizes pollution of any on-site or off-site waters, including wetlands.
- Notwithstanding anything depicted in these plans in words or graphic representation, all design and construction related to roads, storm drainage and erosion control shall conform to the standards and requirements of the most restrictive of the following: a. City of Colorado Springs/El Paso County Engineering Criteria Manual, Volumes 1 and 2, and the El Paso County Engineering Criteria Manual, Volumes 1 and 2. Any deviations from regulations and standards must be requested, and approved, in writing. b. Colorado Stormwater Management Plan (SWMP) for this project shall be completed and an Erosion and Sediment Control Plan (ESCP) shall be submitted to the City of Colorado Springs/El Paso County Engineering Criteria Manual, Volumes 1 and 2, and the El Paso County Engineering Criteria Manual, Volumes 1 and 2. Any deviations from regulations and standards must be requested, and approved, in writing.
- A separate Stormwater Management Plan (SWMP) for this project shall be completed and an Erosion and Sediment Control Plan (ESCP) shall be submitted to the City of Colorado Springs/El Paso County Engineering Criteria Manual, Volumes 1 and 2, and the El Paso County Engineering Criteria Manual, Volumes 1 and 2. Any deviations from regulations and standards must be requested, and approved, in writing.
- Contractor shall be responsible for the notification and field notification of all existing utilities, whether shown on the plans or not, before beginning construction. Location of existing utilities shall be verified by the contractor prior to construction. Call 811 to contact the Utility Notification Center of Colorado (UNCC).
- Contractor shall keep a copy of these approved plans, the Grading and Erosion Control Plan, the Stormwater Management Plan (SWMP), the Erosion and Sediment Control Plan (ESCP), and the appropriate design and construction standards and specifications at the job site at all times, including the following: a. El Paso County Engineering Criteria Manual (ECM) b. City of Colorado Springs/El Paso County Drainage Criteria Manual, Volumes 1 and 2 c. Colorado Department of Transportation (CDOT) Standard Specifications for Road and Bridge Construction d. CDOT M & S Standards
- Notwithstanding anything depicted in these plans in words or graphic representation, all design and construction related to roads, storm drainage and erosion control shall conform to the standards and requirements of the most restrictive of the following: a. City of Colorado Springs/El Paso County Engineering Criteria Manual, Volumes 1 and 2, and the El Paso County Engineering Criteria Manual, Volumes 1 and 2. Any deviations from regulations and standards must be requested, and approved, in writing. Any modifications necessary to meet criteria after-the-fact will be entirely the developer's responsibility to rectify.
- It is the design engineer's responsibility to accurately show existing conditions, both onsite and offsite, on the construction plans. Any modifications necessary due to conflicts, omissions, or changed conditions will be entirely the developer's responsibility to rectify.
- Contractor shall schedule a pre-construction meeting with El Paso County Planning and Community Development (PCD) - Inspections, prior to starting construction.
- It is the contractor's responsibility to understand the requirements of all jurisdictional agencies and to obtain all required permits, including but not limited to El Paso County Erosion and Stormwater Quality Control Permit (ESQCP), Regional Building Floodplain Development Permit, U.S. Army Corps of Engineers-issued 401 and/or 404 permits, and county and state fugitive dust permits.
- Contractor shall not deviate from the plans without first obtaining written approval from the design engineer and PCD. Contractor shall notify the design engineer immediately upon discovery of any errors or inconsistencies.
- All public storm drain pipes shall be Class III RCP unless otherwise noted and approved by PCD.
- County PCD prior to placement of curb and gutter and pavement.
- All construction traffic must enter/exit the site at approved construction access points.
- Signage and striping shall comply with El Paso County DOT and MUTCD criteria. If applicable, additional signing and striping notes will be provided.
- Contractor shall obtain any permits required by El Paso County DOT, including Work Within the Right-of-Way and Special Transport permits.
- The limits of construction shall remain within the property line unless otherwise noted. The owner/developer shall obtain written permission and easements, where required, from adjoining property owner(s) prior to any off-site disturbance, grading, or construction.

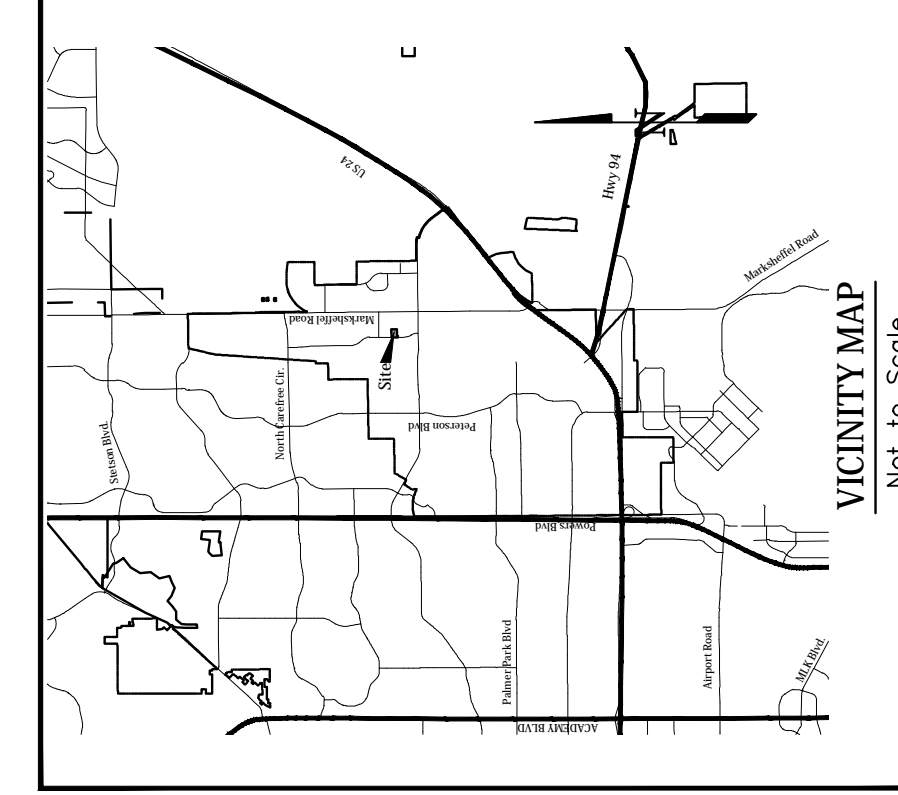
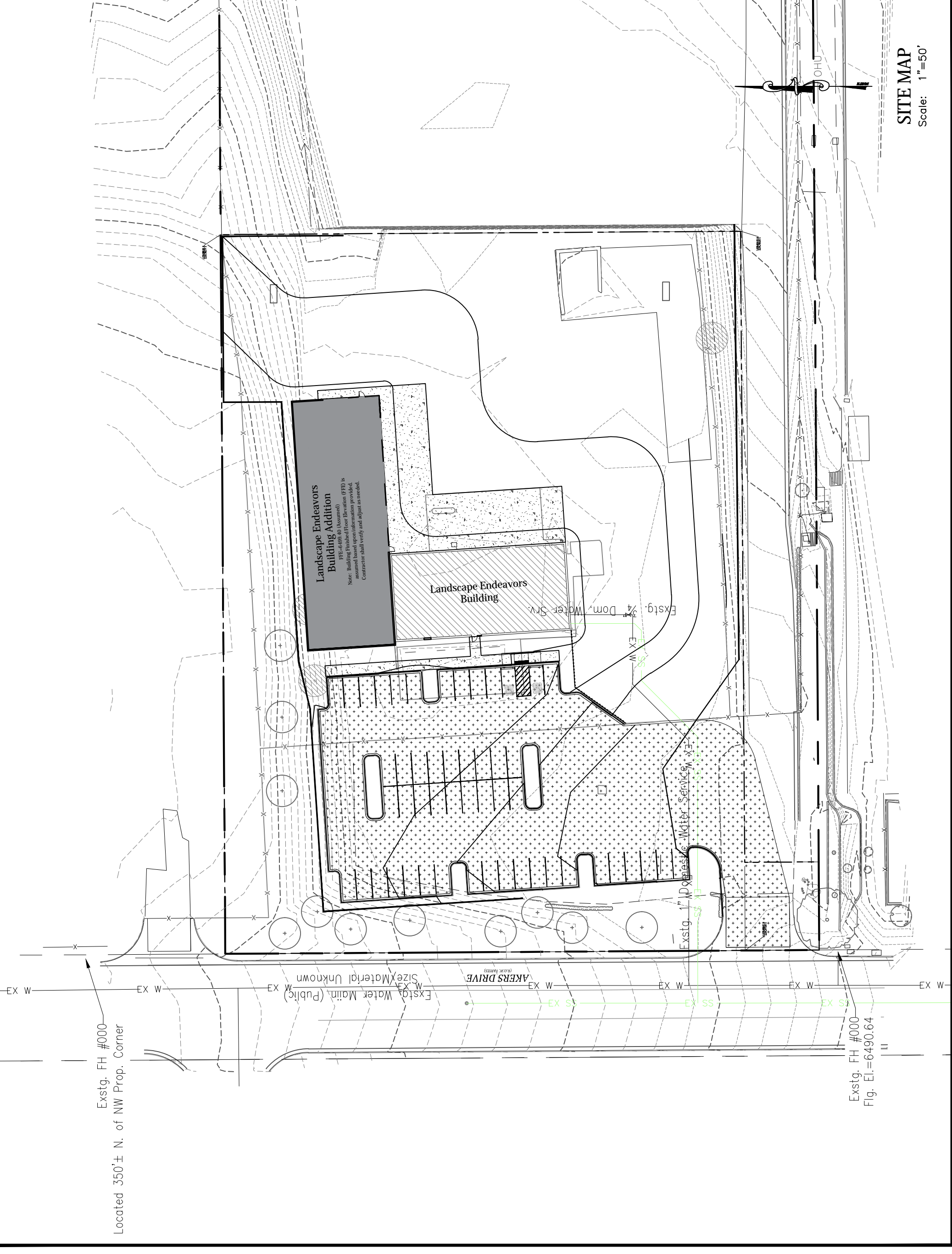

#### INDEX OF SHEETS - GEC Only

Quantity	Unit	Cost	Amount
C300	Grading and Erosion Control Cover Sheet		
C301	Grading and Erosion Control Initial Conditions		
C302	Grading and Erosion Control Interim Conditions		
C303	Grading and Erosion Control Final Conditions		
C304	Grading and Erosion Control Details		

**SITE SOIL TYPE NOTE:**  
The soil type of this site was identified primarily as Blackland heavy sand with slopes ranging from 1-4% and a hydrologic soil grouping of A. Soils associated with hydrologic soil group A have a high/moderate infiltration rate.

**EROSION CONTROL INSPECTION AND MAINTENANCE**  
A thorough inspection of the Erosion Control Plan/Stormwater Management System shall be conducted by the design engineer prior to rain or snowmelt event that causes Surface Erosion:  
• When silt fences have silted up to their height, they shall be repaired or replaced.  
• When silt fences have been damaged or displaced, they shall be repaired or replaced.  
• When silt fences have been removed or displaced, they shall be repaired or replaced.  
• An accumulated trash or debris shall be kept from outlets.  
• An inspection and maintenance log shall be kept.

**SEED MIX**  
Areas disturbed by the earthwork activities and not receiving other treatment shall be permanently revegetated with the following:  
Slopes: Sod Grass, 3.0 lbs/100 sq ft  
Slopes: Sod Grass, 2.5 lbs/100 sq ft  
Western Wheat Grass, 2.0 lbs/100 sq ft  
Little Bluestem, 2.0 lbs/100 sq ft  
Sod Grass, 0.5 lbs/100 sq ft  
Native Prairie, 0.5 lbs/100 sq ft  
Morpho, 28 lbs/100 sq ft  
Seeding Application: Drill seed 1/2" to 3/4" into topsoil. In areas inaccessible to a drill, hand broadcast at double the rate and rake 1/2" to 3/4" into the topsoil. Mulching Application: 1-1/2 tons native hay per acre, mechanically crimped into the topsoil.

**PRE-EXCAVATION CHECKLIST**

- Gas and other utility lines of record shown on the plans.
- Utilities Control Locating called at least 2 business days ahead. (1-800-922-1987)
- Utilities located and marked.
- Employees briefed on marking and color codes.\*
- Employees trained on excavation and safety procedures for natural gas lines.
- When excavation approaches gas lines, employees expose lines by careful probing and hand digging.

\*A.C.A./A.P.W.A. STANDARD UTILITY MARKING COLOR CODE

Natural Gas	Yellow
Electric	Black
Water	Blue
Wastewater	Green

#### OPINION OF COST FOR EROSION CONTROL REQUIREMENTS

Item	Quantity	Unit	Cost	Amount
Vehicle Tracking Control	1	ea	\$3,316.00	\$3,316.00
Silt Fence	557	lf	\$4.00	\$2,228.00
Concrete Wash Out	1	ea	\$1,100.00	\$1,100.00
Maintenance (25% of Erosion Control)	1	ea	\$680.40	\$680.40
			<b>TOTAL</b>	<b>\$7,484.40</b>

**Owner's Statement:**  
I, the owner/developer have read and will comply with the requirements of the Grading and Erosion Control Plan and all of the requirements specified in these detailed plans and specifications.

**Owner Signature:** \_\_\_\_\_ **Date:** \_\_\_\_\_  
Cory Shorette, President  
ADDRESS: CES Endeavors, LLC  
9818 Morning Vista Drive  
Peyton, Colorado 80831

**Review Engineer:** \_\_\_\_\_ **Date:** \_\_\_\_\_  
The Erosion Control Plan was reviewed and found to meet the checklist requirements except where otherwise noted or allowed by an approved deviation request.  
Review Engineer

**PREPARED BY:**  
**Kiowa Engineering Corporation**  
1604 South 21st Street  
Colorado Springs, Colorado 80904  
(719) 630-7342

**DEVELOPER:**  
CES Endeavors, LLC  
9818 Morning Vista Drive  
Peyton, Colorado 80831  
(719) 683-5480



Know what's below.  
Call before you dig.

Project No.: 24060  
Date: January 31, 2025  
Design: AWWC  
Drawn: CAD/JC  
Check: TAC  
Revisions:

Sheet  
**C300**  
of 13 Sheets

Landscape Endeavors Building Addition  
CES Endeavors, LLC  
Grading and Erosion Control - Cover Sheet  
El Paso County, Colorado

**Kiowa Engineering Corporation**  
1604 South 21st Street  
Colorado Springs, Colorado 80904  
(719) 630-7342



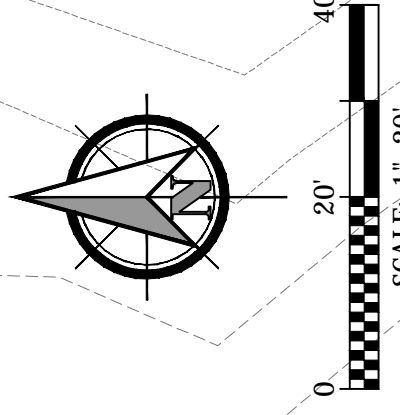

Grading Legend	
EX C	Gas Line (Underground)
EX U/E	Electric Line (Underground)
EX T	Telephone Line (Underground)
█	Accessible Route
▨	Concrete Sidewalk
▩	Concrete Gutter/Pan
▧	Asphalt Mill & Overlay
+	Spot Elevation
— 16.04	Existing or Proposed
→	Flow Direction Arrow/Slope
→	Existing or Proposed
→	Flow Direction Arrow/Slope
→	Existing or Proposed
---	Limits Of Disturbance Construction Site Boundary
---	Existing Index Contour
---	Proposed Index Contour
---	Proposed Inter. Contour
---	Property Line
---	Proposed Ditch Flowline
---	Proposed 4" PVC Sleeve (Water Quality)
---	Proposed Curb Type Designation

Erosion Control Legend	
SF	Silt Fence or Sediment Control Log
SCL	Sediment Control Log
CF	Construction Fence
RS	Rock Sock
IP-1	Inlet Protection
IP-2	Inlet Protection
CWA	Concrete Washout Area*
SSA	Stabilized Staging Area*
PT	Portable Toilet*
SP	Stock Pile Management*
VTC	Vehicle Tracking (Feeds Alternate)

\*To Be Determined By The Contractor

**TRACT 5 AKERS ACRES SUBDIVISION NO.1**  
APN: 533202007  
OWNER: CES ELECTRONIC, LLC  
ADDRESS: 7655 ELECTRONIC DR.

**Landscaping Endeavors Building Addition**  
FFE-6499.40 (Assumed)  
Note: Building Finished Floor Elevation (FFE) is assumed based upon information provided. Contractor shall verify and adjust as needed.

**Landscaping Endeavors Building**

**LOT 6 AKERS ACRES SUBDIVISION NO.1**  
OWNER: CV MARKS/CEFFER/PROPERTY LLC  
ADDRESS: 2775 AKERS DR.

**LOT 1 SEDER SUBDIVISION**  
APN: 533244003  
OWNER: CES ELECTRONIC, LLC  
ADDRESS: 2725 AKERS DR.

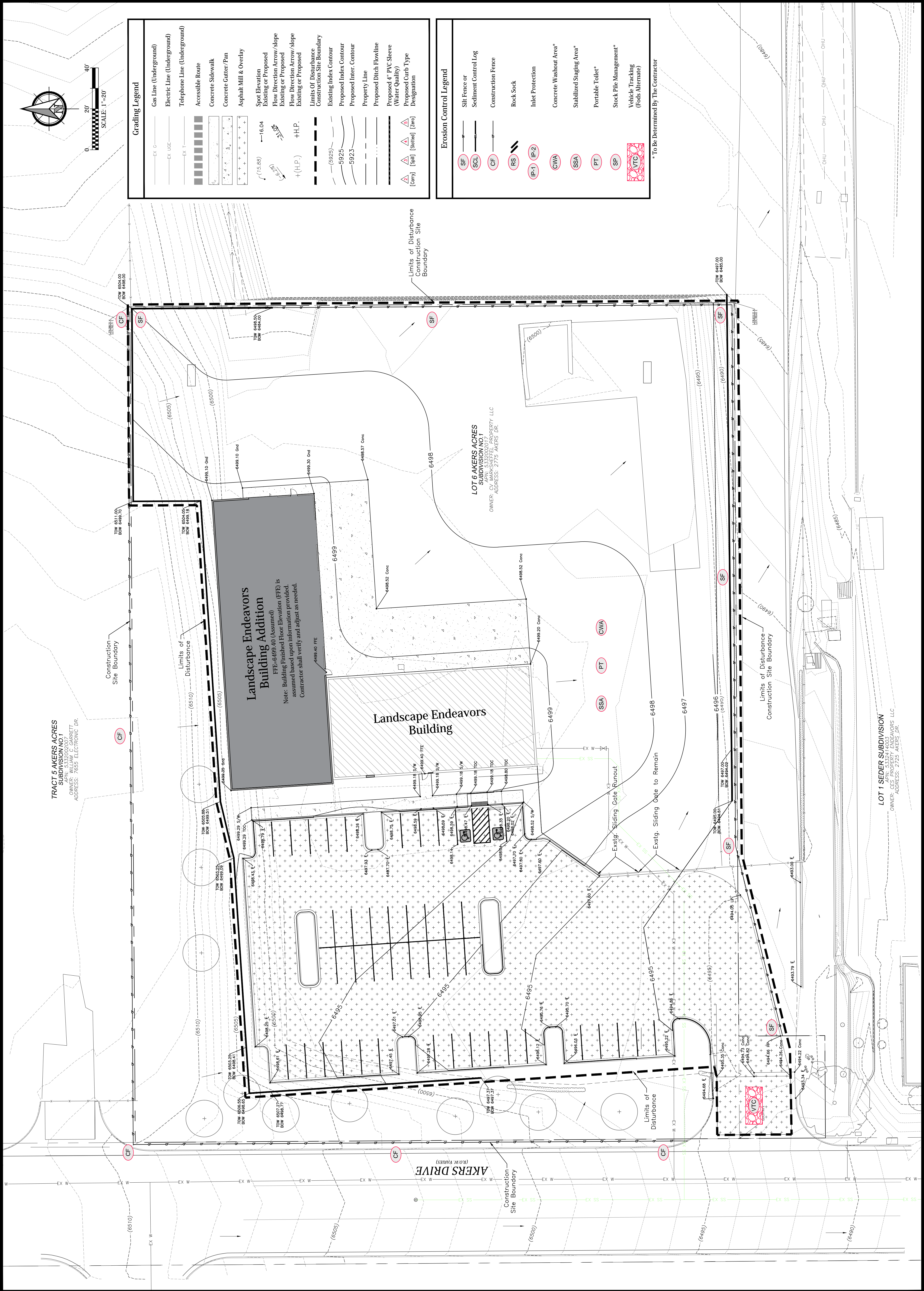



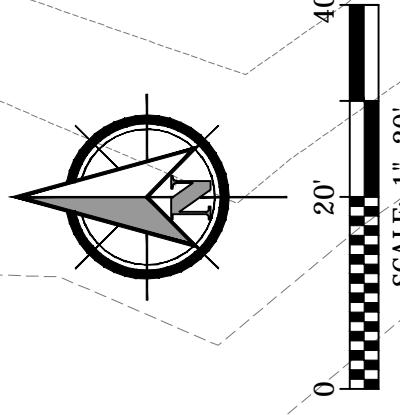

**Grading Legend**

EX C	Gas Line (Underground)
EX U/E	Electric Line (Underground)
EX T	Telephone Line (Underground)
+	Accessible Route
—	Concrete Sidewalk
—	Concrete Gutter/Pan
—	Asphalt Mill & Overlay
•	Spot Elevation
—	Flow Direction Arrow/Slope Existing or Proposed
—	Flow Direction Arrow/Slope Existing or Proposed
—	Flow Direction Arrow/Slope Existing or Proposed
—	Limits Of Disturbance Construction Site Boundary
—	Existing Index Contour
—	Proposed Index Contour
—	Proposed Index Contour
—	Property Line
—	Proposed Ditch Flowline
—	Proposed 4" PVC Sleeve (Water Quality)
—	Proposed Curb Type Designation

**Erosion Control Legend**

SF	Silt Fence or Sediment Control Log
CF	Construction Fence
RS	Rock Sock
IP-1	Inlet Protection
IP-2	Inlet Protection
CWA	Concrete Washout Area*
SSA	Stabilized Staging Area*
PT	Portable Toilet*
SP	Stock Pile Management*
VTC	Vehicle Tracking (Feeds Alternate)

\*To Be Determined By The Contractor

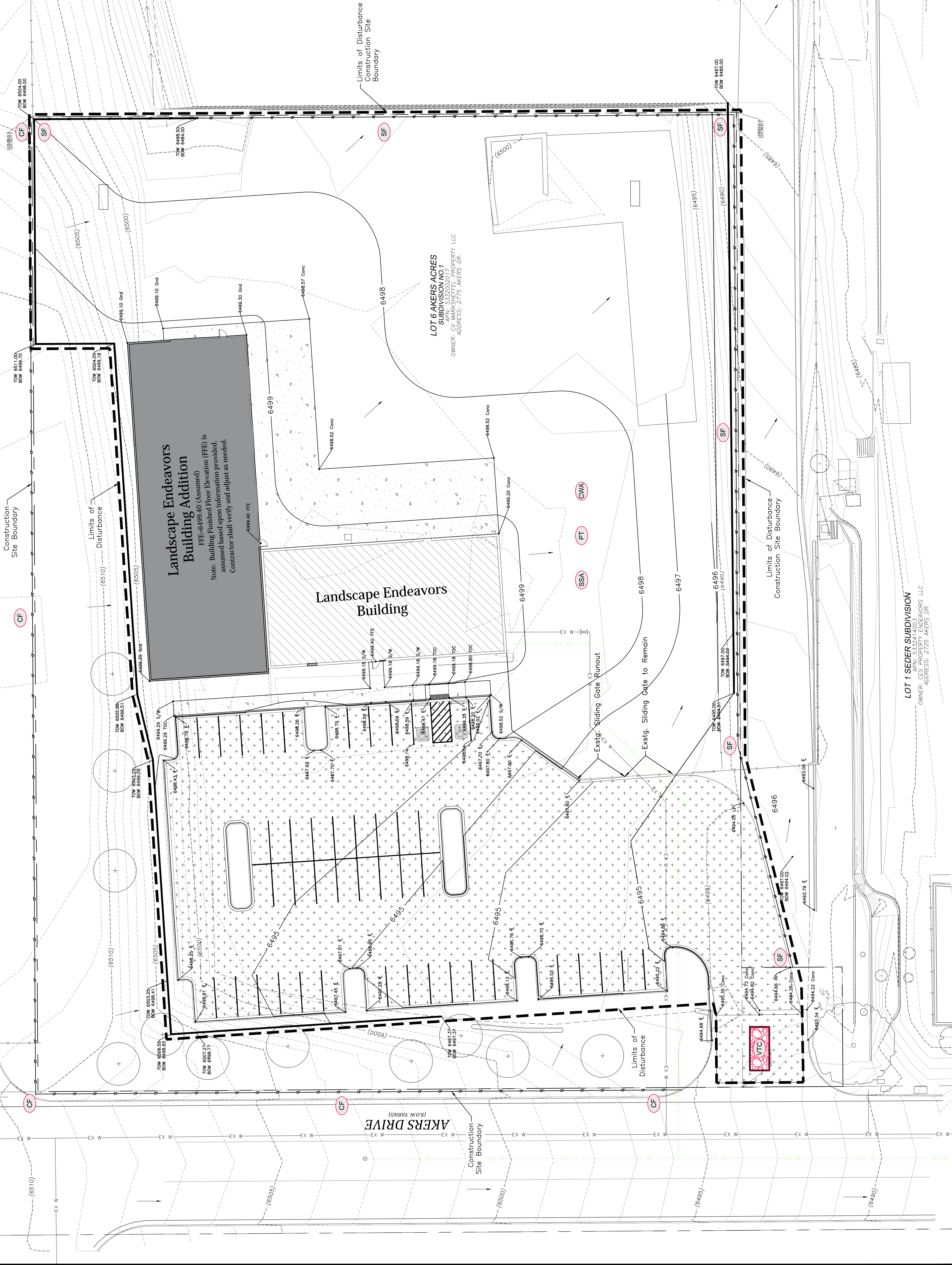

**TRACT 5 AKERS ACRES SUBDIVISION NO.1**  
APN: 5332702007  
OWNER: C&S ELECTRONIC PROPERTY, LLC  
ADDRESS: 7655 ELECTRONIC DR.

**Landscape Endeavors Building Addition**  
FFE-6499.40 (Assumed)  
Note: Building Finished Floor Elevation (FFE) is assumed based upon information provided. Contractor shall verify and adjust as needed.

**Landscape Endeavors Building**

**LOT 6 AKERS ACRES SUBDIVISION NO.1**  
OWNER: CV MARKS EFFE PROPERTY LLC  
ADDRESS: 2775 AKERS DR.

**LOT 1 SEDER SUBDIVISION**  
APN: 533244003  
OWNER: CES ENDEAVORS, LLC  
ADDRESS: 2725 AKERS DR.



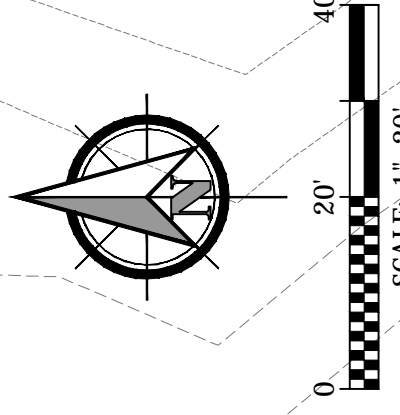

Grading Legend	
EX G	Gas Line (Underground)
EX UOE	Electric Line (Underground)
EX T	Telephone Line (Underground)
+	Accessible Route
—	Concrete Sidewalk
—	Concrete Gutter/Pan
—	Asphalt Mill & Overlay
•	Spot Elevation
→	Flow Direction Arrow/slope Existing or Proposed
→	Flow Direction Arrow/slope Existing or Proposed
→	Flow Direction Arrow/slope Existing or Proposed
—	Limits of Disturbance Construction Site Boundary
—	Existing Index Contour
—	Proposed Index Contour
—	Proposed Inter. Contour
—	Property Line
—	Proposed Ditch Flowline
—	Proposed 4" PVC Sleeve (Water Quality)
—	Proposed Curb Type Designation
△ (arry)	△ (arry) [Sloped] [Area]
△ (arry)	△ (arry) [Sloped] [Area]
△ (arry)	△ (arry) [Sloped] [Area]

Erosion Control Legend	
SF	Silt Fence or Sediment Control Log
CF	Construction Fence
RS	Rock Sock
IP-1	Inlet Protection
IP-2	Inlet Protection
CWA	Concrete Washout Area*
SSA	Stabilized Staging Area*
PT	Portable Toilet*
SP	Stock Pile Management*
TC	Vehicle Tracking (Fods Alternate)

\* To Be Determined By The Contractor

**TRACT 5 AKERS ACRES SUBDIVISION NO.1**  
APN: 5332702007  
OWNER: CFS ENDEAVORS LLC  
ADDRESS: 7655 ELECTRONIC DR.

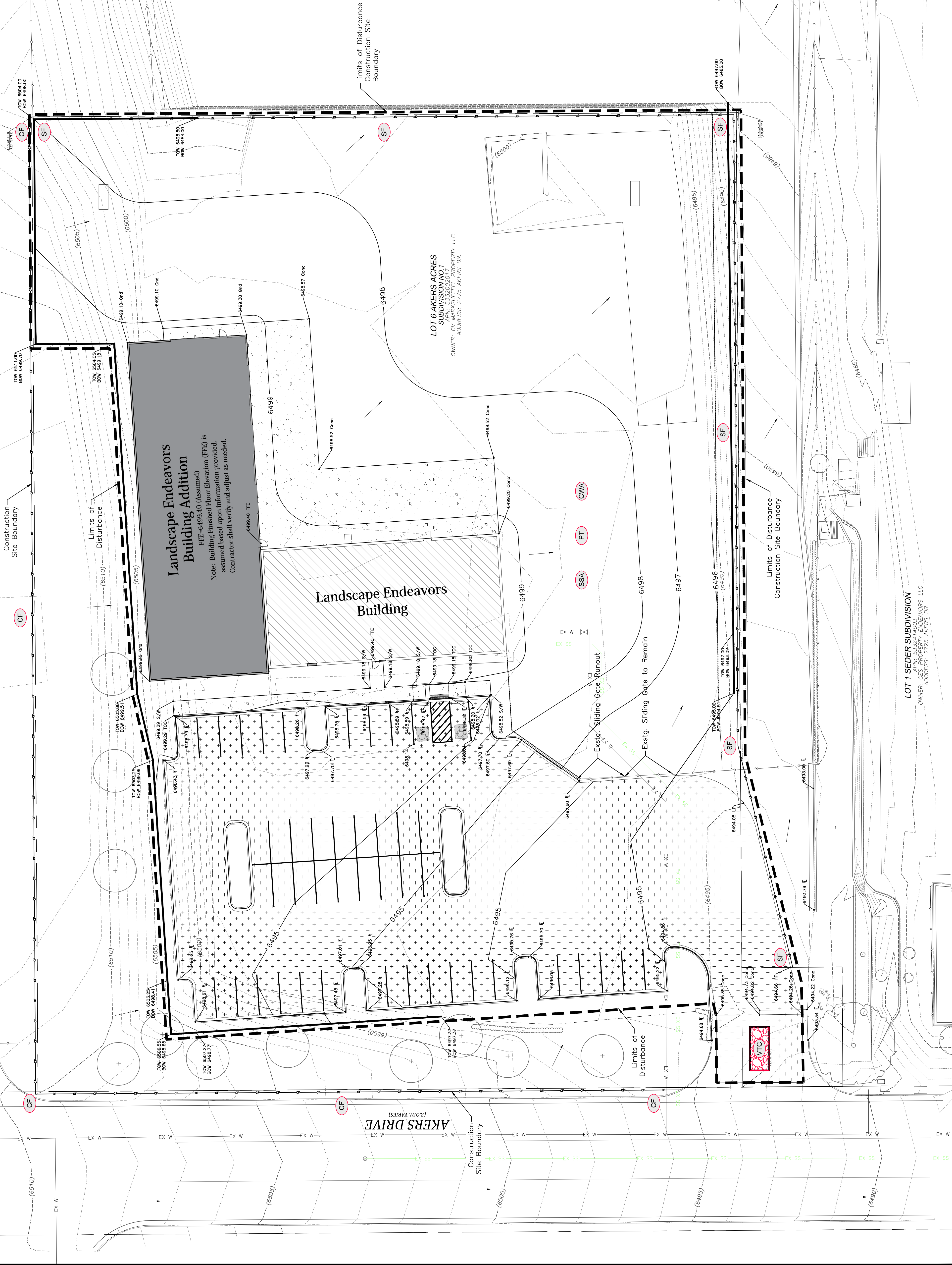

**LOT 1 SEDER SUBDIVISION**  
APN: 5332414003  
OWNER: CFS ENDEAVORS LLC  
ADDRESS: 2725 AKERS DR.







**SM-3 Construction Fence (CF)**

- CONSTRUCTION FENCE MAINTENANCE NOTES**
1. INSPECT BUMP EACH WEEKEND AND MAINTAIN THEM IN EFFECTIVE OPERATING CONDITION. MAINTENANCE OF BMPs SHOULD BE PROACTIVE, NOT REACTIVE. INSPECT BMPs AS SOON AS POSSIBLE (AND ALWAYS WITHIN 24 HOURS) FOLLOWING A STORM THAT CAUSES SURFACE DAMAGE TO THE BMP.
  2. FREQUENT OPERATIONS AND MAINTENANCE ARE NECESSARY TO MAINTAIN BMPs IN EFFECTIVE OPERATING CONDITION. INSPECTIONS AND CORRECTIVE MEASURES SHOULD BE DOCUMENTED THOROUGHLY.
  3. WHERE BMPs HAVE FAILED, REPAIR OR REPLACEMENT SHOULD BE INITIATED UPON DISCOVERY OF THE FAILURE.
  4. WHEN CONSTRUCTION FENCES ARE DAMAGED OR REMOVED, THERE ARE SEVERAL ASPECTS OF DAMAGE SUCH AS TIPS OR SKIDS. CONSTRUCTION FENCE IS TO REMAIN IN PLACE UNTIL THE UPSTREAM DISTURBED AREA IS STABILIZED AND APPROVED BY THE LOCAL JURISDICTION.
  5. WHEN CONSTRUCTION FENCES ARE REMOVED, ALL DELURBED AREAS ASSOCIATED WITH THE FENCE SHOULD BE REVEGETATED WITH TOPSOIL, SEEDING AND MULCHED, OR OTHERWISE STABILIZED AS APPROVED BY LOCAL JURISDICTION.
- NOTE: MANY JURISDICTIONS HAVE BMP DETAILS THAT VARY FROM UFGCD STANDARD DETAILS. LOCAL JURISDICTIONS AS TO WHICH DETAIL SHOULD BE USED WHEN DIFFERENCES ARE NOTED.  
(DETAIL ADAPTED FROM TOWN OF PARKER, COLORADO, NOT AVAILABLE IN AUTOCAD)

**SM-3 Construction Fence (CF)**

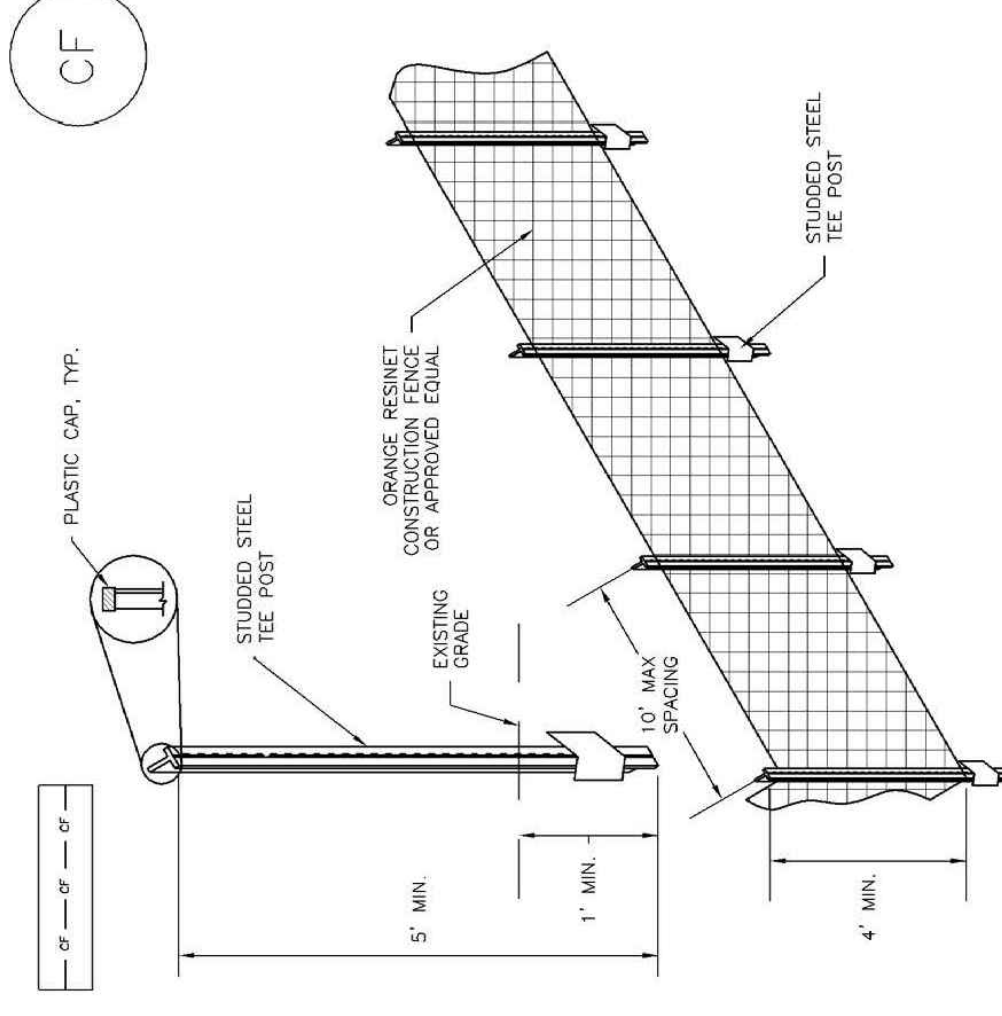

**CF-1.1. PLASTIC MESH CONSTRUCTION FENCE**

- CONSTRUCTION FENCE INSTALLATION NOTES**
1. SEE PLAN VIEW FOR:
    - LOCATION OF CONSTRUCTION FENCE.
  2. CONSTRUCTION FENCE SHOWN SHALL BE INSTALLED PRIOR TO ANY LAND DISTURBING ACTIVITIES.
  3. CONSTRUCTION FENCE SHALL BE COMPOSED OF ORANGE CONSTRUCTION-ORANGE MATERIAL THAT IS AT LEAST 4' HIGH. METAL POSTS SHOULD HAVE A PLASTIC CAP FOR SAFETY.
  4. STUDDED STEEL TEE POSTS SHALL BE UTILIZED TO SUPPORT THE CONSTRUCTION FENCE. MAXIMUM SPACING FOR STEEL TEE POSTS SHALL BE 10'.
  5. CONSTRUCTION FENCE SHALL BE SECURELY FASTENED TO THE TOP, MIDDLE, AND BOTTOM OF EACH POST.

November 2010 Urban Drainage and Flood Control District Urban Storm Drainage Criteria Manual Volume 3

November 2010 Urban Drainage and Flood Control District Urban Storm Drainage Criteria Manual Volume 3

CF-2

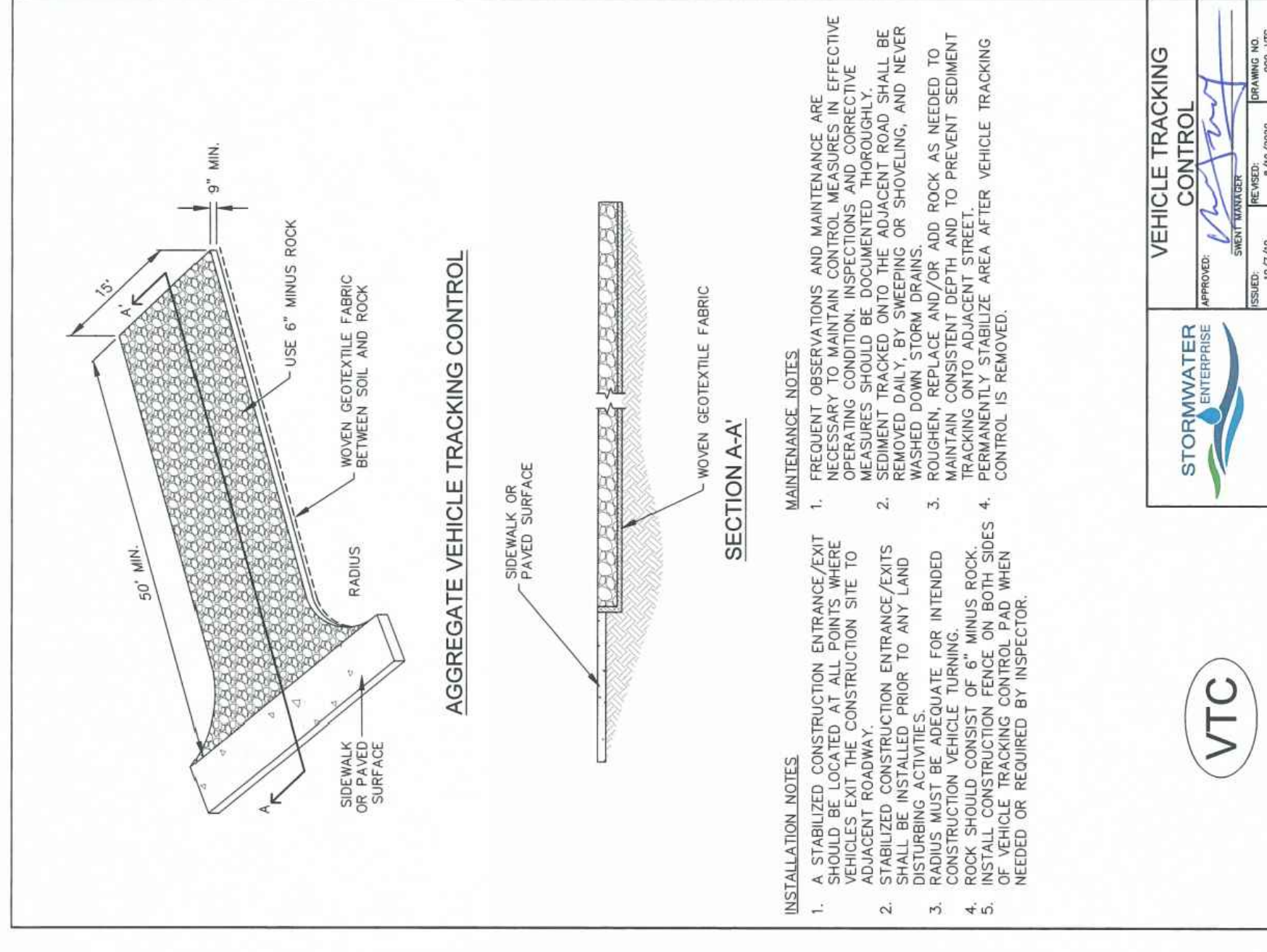

- INSTALLATION NOTES**
1. A STABILIZED CONSTRUCTION ENTRANCE/EXIT SHOULD BE LOCATED AT ALL POINTS WHERE TRAFFIC ENTERS OR EXITS THE CONSTRUCTION SITE TO ADJACENT ROADWAYS.
  2. STABILIZED CONSTRUCTION ENTRANCE/EXITS SHOULD BE INSTALLED PRIOR TO ANY LAND DISTURBING ACTIVITIES.
  3. RADIUS MUST BE ADEQUATE FOR INTENDED PURPOSES.
  4. ROCK SHOULD CONSIST OF 6" MINUS ROCK.
  5. INSTALL CONSTRUCTION FENCE ON BOTH SIDES OF THE TRACKING CONTROL AREA WHEN NEEDED OR REQUIRED BY INSPECTOR.
- MAINTENANCE NOTES**
1. FREQUENT OBSERVATIONS AND MAINTENANCE ARE NECESSARY TO MAINTAIN CONTROL MEASURES IN EFFECTIVE OPERATING CONDITION. INSPECTIONS AND CORRECTIVE MEASURES SHOULD BE DOCUMENTED THOROUGHLY.
  2. SEDIMENT TRACKED ONTO THE ADJACENT ROAD SHALL BE WASHED DOWN STORM DRAINS, OR SHOVELING, AND NEVER DISTURBING ACTIVITIES.
  3. ROUGHEN, REPLACE AND/OR ADD ROCK AS NEEDED TO PERMANENTLY STABILIZE AREA AFTER VEHICLE TRACKING CONTROL IS REMOVED.

**VTC**

**STORMWATER VULNERABILITY**

**VEHICLE TRACKING CONTROL**

DESIGNED BY: *[Signature]*  
DATE: 10/17/18  
SCALE: 1/8"=1'-0"  
DRAWING NO.: 200-175