



INNOVATIVE DESIGN. CLASSIC RESULTS.

**FINAL DRAINAGE REPORT  
FOR  
MONUMENT JUNCTION DEVELOPMENT  
HIGHWAY 105 CORRIDOR &  
JACKSON CREEK PARKWAY  
INTERSECTION IMPROVEMENTS**

July 2023

**CCES  
RESPONSES**

Prepared for:  
ELITE PROPERTIES OF AMERICA, INC  
2138 FLYING HORSE CLUB DR.  
COLORADO SPRINGS, CO 80921

Prepared by:  
CLASSIC CONSULTING  
619 N. CASCADE AVE., SUITE 200  
COLORADO SPRINGS CO 80903  
(719) 785-0790

Job no. 1302.22



# FINAL DRAINAGE REPORT FOR MONUMENT JUNCTION DEVELOPMENT – HIGHWAY 105 CORRIDOR & JACKSON CREEK PARKWAY INTERSECTION IMPROVEMENTS

## DRAINAGE REPORT STATEMENT

### ENGINEER'S STATEMENT:

The attached drainage plan and report were prepared under my direction and supervision and are correct to the best of my knowledge and belief. Said drainage report has been prepared according to the criteria established by the Town for drainage reports and said report is in conformity with the master plan of the drainage basin. I accept responsibility for any liability caused by any negligent acts, errors, or omissions on my part in preparing this report.

\_\_\_\_\_  
Marc A. Whorton, Colorado P.E. #37155

\_\_\_\_\_  
Date

### DEVELOPER'S STATEMENT:

I, the developer, have read and will comply with all of the requirements specified in this drainage report and plan.

Business Name: ELITE PROPERTIES OF AMERICA, INC.

By: \_\_\_\_\_

Title: \_\_\_\_\_

Address: 2138 FLYING HORSE CLUB DR.

COLORADO SPRINGS, CO 80921

### TOWN OF MONUMENT:

Filed in accordance with Sections 12.13.010 of the Subdivision Ordinance for the Town of Monument, revised 1997 and 13.11.160 of the Zoning Ordinance for the Town of Monument, revised 1997.

\_\_\_\_\_  
For Town of Monument

\_\_\_\_\_  
Date

### EL PASO COUNTY:

Filed in accordance with the requirements of the Drainage Criteria Manual, Volumes 1 and 2, El Paso County Engineering Criteria Manual and Land Development Code as amended.

\_\_\_\_\_  
Joshua Palmer, P.E.

County Engineer, / ECM Administrator

*(Review only for Hwy. 105 intersection design east of Jackson Creek Pkwy.)*

\_\_\_\_\_  
Date



# FINAL DRAINAGE REPORT FOR MONUMENT JUNCTION DEVELOPMENT – HIGHWAY 105 CORRIDOR & JACKSON CREEK PARKWAY INTERSECTION IMPROVEMENTS

## TABLE OF CONTENTS:

PURPOSE	Page 1
GENERAL DESCRIPTION	Page 1
EXISTING DRAINAGE CONDITIONS	Page 1
PROPOSED DRAINAGE CHARACTERISTICS	Page 4
DRAINAGE CRITERIA	Page 8
FLOODPLAIN STATEMENT	Page 8
SUMMARY	Page 8
REFERENCES	Page 10

## APPENDICES

VICINITY MAP
SOILS MAP (S.C.S. SURVEY)
F.E.M.A. MAP
JURISDICTIONAL DETERMINATION
HYDROLOGIC / HYDRAULIC CALCULATIONS
STORMWATER QUALITY / DETENTION CALCULATIONS
DRAINAGE MAPS



## **PURPOSE**

This document is the Final Drainage Report for the Monument Junction Development and the associated adjacent off-site improvements to Highway 105 and the intersection with Jackson Creek Parkway. The purpose of this report is to identify the existing drainage patterns in this corridor, define and detail practical solutions for the conveyance and attenuation of developed flows to minimize drainage impacts further downstream resulting from these regional roadway improvements as required by Town of Monument, El Paso County and CDOT. **Two separate reports cover the on-site aspects of the Monument Junction Development. Please reference “Monument Junction East – Phase 1 PD Site Plan” and “Monument Junction West Filing No. 1”, both prepared by Classic Consulting. These reports have been approved by the Town of Monument and detail and describe all the on-site drainage design for the development.**

## **GENERAL DESCRIPTION**

This report covers the Highway 105 corridor from the I-25 off-ramp to the Knollwood Drive intersection and the Jackson Creek Parkway improvements from Highway 105 to the high point in the road approximately 750 feet south of Highway 105. This area lies within Section 14, township 11 south, range 67 west of the 6<sup>th</sup> principal meridian, in El Paso County. This corridor is bounded on the north by CDOT property and private rural residential property, to the south by Monument Junction development and various commercial developments along Highway 105, to the east by existing Village Center at Woodmoor development and to the west by existing CDOT Right-of-way (Interstate-25).

The average soil condition reflects Hydrologic Group “D” (Alamosa Loam) as determined by the “Web Soil Survey of El Paso County Area,” prepared by the Soil Conservation Service (see map in Appendix).

## **EXISTING DRAINAGE CONDITIONS**

This corridor is entirely within the Dirty Woman Creek drainage basin. Existing slopes range from 1% to 33% and ground cover is predominantly paved roadway with native grass sideroad ditches with some trees and wetlands within the corridor. The current drainage pattern flows generally in a westerly direction towards the intersection of Highway 105 and the I-25 off-ramp where an existing 36” RCP culvert crosses the I-25 off-ramp. This natural drainageway just upstream of this facility contains wetland area within the natural channel behind the sidewalk along the south side of Highway 105. Please reference the Jurisdictional Determination (JD) Action No. SPA-2022-00180 that finds these wetlands to be non-jurisdictional. (See Appendix) The corridor east of Jackson Creek



Parkway contains an existing storm system collecting the developed street flows and the adjacent property along the south side of Highway 105.

The following off-site basins (OS-10 thru OS-18) are all along this stretch of the Highway 105 corridor east to Knollwood Drive including the intersection with Jackson Creek Parkway:

**Basin OS-10 ( $Q_5= 3$  cfs,  $Q_{100}= 10$  cfs)** consists of the off-site property within the existing Right-of-Way for Highway 105 and the I-25 off-ramp. These flows travel as sheet flow in a northerly direction directly into the sideroad ditch along the south side of Highway 105 and the east side of the I-25 off-ramp. The flows then travel as ditch flow towards the intersection with the I-25 off-ramp. The total flows at this location are described later as Design Point H10.

**Basin OS-16 ( $Q_5= 2$  cfs,  $Q_{100}= 5$  cfs)** consists of the off-site fully developed properties east of Jackson Creek Parkway and south of Highway 105. This basin consists of existing buildings, parking lot, drive aisle and landscape area. These developed flows travel into a landscape sediment area adjacent to the buildings and then directly into Basin OS-11. **Basin OS-11 ( $Q_5= 3$  cfs,  $Q_{100}= 6$  cfs)** consists of the off-site partially developed property due east of Jackson Creek Parkway just south of Highway 105. This basin consists of an existing building, parking lot, driveway and native planted slope adjacent to Jackson Creek Parkway. The combined developed flows travel in a westerly direction and directly into the sideroad ditch along Jackson Creek Parkway. However, the ditch on the east side of the road seems to end and these flows appear to spillover to the westerly side of the roadway (Design Point H7) as the northbound approach to the intersection with Highway 105 is superelevated due to the grade on Highway 105. At **Design Point H7 ( $Q_5= 5$  cfs,  $Q_{100}= 10$  cfs)** these combined flows are partially collected by an existing 10' Type R at-grade inlet ( $Q_5= 4.9$  cfs,  $Q_{100}= 7.7$  cfs) with a flow-by of ( $Q_5= 0.1$  cfs,  $Q_{100}= 2.3$  cfs). This minor flow-by continues around the corner and then in a westerly direction down the street within Basin OS-17. The collected flows along with the upstream flows are conveyed in an existing 30" RCP storm pipe and daylight into the sideroad ditch along the south side of Highway 105.

**Basin OS-12 ( $Q_5= 1.2$  cfs,  $Q_{100}= 3$  cfs)** consists of the most easterly portion of Highway 105 at the Knollwood Drive intersection. Portions of this basin include the existing paved roadway and naturally landscaped area within the ROW. It has been assumed that the upstream facilities (east of Knollwood Dr.) capture 100% of the minor flows but approximately 0.85 cfs bypass those facilities in the major event. (*Information taken from recent "Preliminary Drainage Report Highway 105 Project A", prepared by HDR for El Paso County, dated November 2021*) Thus, the



total flows are conveyed via curb and gutter in a westerly direction towards **Design Point H4** ( $Q_5= 1 \text{ cfs}$ ,  $Q_{100}= 3.8 \text{ cfs}$ ). At this location, an existing 5' Type R at-grade inlet collects a portion of these flows ( $Q_5= 1 \text{ cfs}$ ,  $Q_{100}= 2.5 \text{ cfs}$ ) with a flow-by of ( $Q_5= 0 \text{ cfs}$ ,  $Q_{100}= 1.3 \text{ cfs}$ ). This minor flow-by continues in a westerly direction down the street within Basin OS-13. The collected flows are conveyed in an existing 15" RCP storm pipe in a westerly direction under Highway 105.

**Basin OS-13** ( $Q_5= 2 \text{ cfs}$ ,  $Q_{100}= 4 \text{ cfs}$ ) consists of a portion of Highway 105 west of Knollwood Drive. Portions of this basin include the existing paved roadway and naturally landscaped area within the ROW. These flows along with the minor 100 yr. flow-by from Design Point H4 are conveyed via curb and gutter in a westerly direction towards **Design Point H5**. At this location, an existing 10' Type R at-grade inlet collects a portion of these flows ( $Q_5= 2 \text{ cfs}$ ,  $Q_{100}= 4.9 \text{ cfs}$ ) with a flow-by of ( $Q_5= 0 \text{ cfs}$ ,  $Q_{100}= 0.4 \text{ cfs}$ ). This minor flow-by continues in a westerly direction down the street within Basin OS-14. The collected flows combine with the upstream system and are conveyed in an existing 15" RCP storm pipe in a westerly direction.

**Basin OS-14** ( $Q_5= 0.8 \text{ cfs}$ ,  $Q_{100}= 2 \text{ cfs}$ ) consists of a portion of Highway 105 just east of Jackson Creek Parkway. Portions of this basin include the existing paved roadway and naturally landscaped area within the ROW. These flows along with the 100 yr. flow-by from Design Point H5 are conveyed via curb and gutter in a westerly direction towards **Design Point H6**. At this location, an existing 10' Type R at-grade inlet completely collects these flows with no flow-by. The total collected flows are then conveyed in an existing 24" RCP storm pipe in a southwesterly direction.

**Basin OS-15** ( $Q_5= 4 \text{ cfs}$ ,  $Q_{100}= 8 \text{ cfs}$ ) consists of the off-site partially developed property due east of Jackson Creek Parkway just south of Highway 105. This basin consists of existing buildings, parking lots, drive aisles and native undeveloped areas. These developed flows generally travel in a westerly direction towards a sediment basin up on top of the slope at the intersection with Jackson Creek Parkway. This facility does not seem to have any formal stormwater quality features but rather just a rip-rap basin with an existing 18" ADS storm outfall. This outfall conveys the flows directly into a grated inlet behind the curb along the east side of Jackson Creek Parkway. The flows are then conveyed under the roadway within an existing 30" RCP storm system. This system daylights into the sideroad ditch at the SW corner of Highway 105 and Jackson Creek Parkway.

**Basin OS-17** ( $Q_5= 2 \text{ cfs}$ ,  $Q_{100}= 4 \text{ cfs}$ ) consists of a portion of Highway 105 within the intersection with Jackson Creek Parkway. The majority of this basin includes the existing paved roadway along with an area naturally landscaped



slope at the SE corner of the intersection. These flows along with the by-pass flows from Design Point H7 described above are conveyed via curb and gutter in a westerly direction towards **Design Point H8 (Q<sub>5</sub>= 2.1 cfs, Q<sub>100</sub>= 6.3 cfs)**. At this location, an existing 10' Type R at-grade inlet collects a portion of these flows (**Q<sub>5</sub>= 2.1 cfs, Q<sub>100</sub>= 5.5 cfs**) with a flow-by of (**Q<sub>5</sub>= 0 cfs, Q<sub>100</sub>= 0.8 cfs**). This minor flow-by continues in a westerly direction down the street within Basin OS-18. The collected flows are conveyed out of the back of the inlet via a 24" RCP directly into the sideroad ditch along the south side of Highway 105.

**Basin OS-18 (Q<sub>5</sub>= 1.3 cfs, Q<sub>100</sub>= 2 cfs)** consists of a portion of Highway 105 just east of the intersection with the I-25 off-ramp. All of this basin includes the existing paved roadway. These flows along with the by-pass flows from Design Point H8 described above are conveyed via curb and gutter in a westerly direction towards **Design Point H9 (Q<sub>5</sub>= 1 cfs, Q<sub>100</sub>= 3 cfs)**. At this location, an existing 10' Type R sump inlet completely collects these flows. The collected flows are conveyed out of the back of the inlet via a 24" RCP directly into the sideroad ditch along the south side of Highway 105.

**Design Point H10 (Q<sub>5</sub>= 14 cfs, Q<sub>100</sub>= 36 cfs)** consists of the total combined flows from all the tributary upstream basins described above. At this location, the natural ditch within CDOT ROW conveys the flows to an existing 36" RCP culvert under the I-25 off-ramp. This facility seems to adequately handle these current developed flows.

#### **PROPOSED DRAINAGE CONDITIONS**

Developed runoff from the proposed off-site public roadway improvements within the Highway 105 and Jackson Creek Parkway ROW corridors will be conveyed via surface drainage and public storm sewer systems to a proposed permanent storm water quality facility located at the SE corner of the intersection of the I-25 off-ramp and Highway 105. Given that these improvements span multiple jurisdictions, the proposed facilities will be designed and installed per the latest El Paso County ECM and Town of Monument drainage criteria and detailed in this report. See the following general descriptions of the anticipated developed design points and how all the developed flows will be mitigated:

**Design Point D4 (Q<sub>5</sub>= 1.4 cfs, Q<sub>100</sub>= 3.9 cfs)** consists of the most easterly portion of Highway 105 at the Knollwood Drive intersection within Basin OS12D. Portions of this basin include the existing paved roadway and naturally landscaped area within the ROW and new roadway improvements proposed by El Paso County. These developed flows include the minor 100 yr. flow-by of 0.85 cfs as described in the "Preliminary Drainage Report Highway 105



Project A", prepared by HDR for El Paso County, dated November 2021. The total flows are conveyed via curb and gutter in a westerly direction towards Design Point H4. At this location, a proposed 5' Type R at-grade inlet collects a portion of these flows (**Q<sub>5</sub>= 1.4 cfs, Q<sub>100</sub>= 2.5 cfs**) with a flow-by of (**Q<sub>5</sub>= 0 cfs, Q<sub>100</sub>= 1.3 cfs**). This minor flow-by continues in a westerly direction down the street within Basin OS13D. The collected flows are conveyed in a proposed 18" RCP storm pipe in a westerly direction under Highway 105. This proposed inlet and 18" RCP storm will be constructed as a part of the El Paso County Highway 105 Project A.

**Design Point D5 (Q<sub>5</sub>= 2 cfs, Q<sub>100</sub>= 5 cfs)** consists of a portion of the redeveloped Highway 105 by El Paso County. At this location, a proposed 10' Type R at-grade inlet collects a portion of these flows (**Q<sub>5</sub>= 2 cfs, Q<sub>100</sub>= 4.9 cfs**) with a flow-by of (**Q<sub>5</sub>= 0 cfs, Q<sub>100</sub>= 0.4 cfs**). This minor flow-by continues in a westerly direction down the street within Basin OS14D. The collected flows combine with the upstream system and are conveyed in a proposed 18" RCP storm pipe in a westerly direction. This proposed inlet and 24" RCP storm will be constructed as a part of the El Paso County Highway 105 Project A.

**Design Point D6 (Q<sub>5</sub>= 4 cfs, Q<sub>100</sub>= 8 cfs)** consists of the off-site partially developed property due east of Jackson Creek Parkway just south of Highway 105. Basin OS-15D is the upstream basin that consists of existing buildings, parking lots, drive aisles and native undeveloped areas. These developed flows generally travel in a westerly direction and will continue to be captured by a proposed CDOT Type C inlet within their property, located behind the proposed retaining wall. Appropriate easement documents and agreements will need to be granted prior to construction. The collected flows will then be routed via a proposed 18" RCP pipe routed towards the proposed storm system within Highway 105. These flows then combine with the upstream flows described earlier and are conveyed further downstream in a westerly direction.

**Design Point D7 (Q<sub>5</sub>= 6 cfs, Q<sub>100</sub>= 12 cfs)** consists of a portion of the proposed Jackson Creek Parkway road improvements and a few off-site basins to the east that are tributary to this location (Basins OS-16 and OS11D). Developed flows from these basins sheet flow towards Jackson Creek Parkway and enter the roadway. This portion of the road will remain superelevated and the flows sheet flow towards the median and a proposed 10' Type R at-grade inlet. This facility collects a portion of these flows (**Q<sub>5</sub>= 5.4 cfs, Q<sub>100</sub>= 8.2 cfs**) with a flow-by of (**Q<sub>5</sub>= 0.6 cfs, Q<sub>100</sub>= 3.8 cfs**). This flow-by continues in a northerly direction down the street within Basin OS14D. The collected flows are conveyed in a proposed 18" RCP storm pipe in a northerly direction.





**Design Point D8 ( $Q_5= 3$  cfs,  $Q_{100}= 8$  cfs)** consists of a portion of the intersection including both proposed Jackson Creek Parkway and Highway 105 road improvements. Developed flow from this basin along with the flow-by described above sheet flow towards the intersection and a proposed 10' Type R sump inlet within the median. This facility completely collects these flows with a maximum ponding elevation of 6". The collected flows combine with the routed upstream flows and are conveyed in a proposed 24" RCP storm pipe in a westerly direction.

**Design Point D9 ( $Q_5= 2$  cfs,  $Q_{100}= 5$  cfs)** consists of a portion of the proposed Jackson Creek Parkway road improvements (Basin JPC7) and the on-site basin G. Developed flows from these basins sheet flow towards Jackson Creek Parkway and enter the roadway as curb and gutter flow towards a proposed 10' Type R at-grade inlet. This facility collects a portion of these flows ( $Q_5= 2$  cfs,  $Q_{100}= 4.8$  cfs) with a flow-by of ( $Q_5= 0$  cfs,  $Q_{100}= 0.2$  cfs). This flow-by continues in a westerly direction down the street within Basin OS17D. The collected flows are conveyed in a proposed 18" RCP storm pipe in a northerly direction.

**Design Point D10 ( $Q_5= 3$  cfs,  $Q_{100}= 6$  cfs)** consists of a portion of the proposed Highway 105 road improvements within Basin OS17D. Developed flows from this basin along with the upstream flow-by sheet flow towards Highway 105. At this location a proposed 10' Type R at-grade inlet is proposed. This facility collects a portion of these flows ( $Q_5= 3$  cfs,  $Q_{100}= 5.4$  cfs) with a flow-by of ( $Q_5= 0$  cfs,  $Q_{100}= 0.8$  cfs). This flow-by continues in a westerly direction down the street within Basin OS18D. The collected flows are conveyed in a proposed 18" RCP storm pipe towards the proposed storm system behind the curb.

**Design Point D11 ( $Q_5= 2$  cfs,  $Q_{100}= 4$  cfs)** consists of a portion of the proposed Highway 105 road improvements within Basin OS18D. Developed flows from this basin along with the minor upstream flow-by sheet flow towards Highway 105. At this location, an existing 10' Type R sump inlet completely collects these flows. The collected flows are conveyed out of the back of the inlet via an existing 24" RCP directly into the proposed SWQ facility.

**Basin H ( $Q_5= 0.4$  cfs,  $Q_{100}= 1.8$  cfs)** consists of a small portion of the proposed commercial development that will likely be landscape area and continue to sheet flow directly into Basin OS10D. **Basin OS10D ( $Q_5= 0.8$  cfs,  $Q_{100}= 4$  cfs)** consists of the existing vegetated slope within CDOT ROW that sheet flows to the sideroad ditch along the east side of the I-25 off-ramp. The combined flows will continue to travel as ditch flow directly into the proposed SWQ facility.



**Design Point 13 (Q<sub>5</sub>= 18 cfs, Q<sub>100</sub>= 40 cfs)** consists of the total combined developed flows from all the tributary upstream basins within the Highway 105 corridor and Jackson Creek Parkway intersection described above. These developed flows compare to the pre-development flows as follows:

Developed Flows at exist. 36" RCP at I-25 off-ramp: **(Q<sub>5</sub> = 18 cfs, Q<sub>100</sub> = 40 cfs)**

Pre-developed flows at exist. 36" RCP at I-25 off-ramp: **(Q<sub>5</sub> = 14 cfs, Q<sub>100</sub> = 36 cfs)**

A proposed SWQ/detention facility is planned within CDOT Right-of-way to help manage the additional impervious area introduced within this roadway corridor created by the public roadway improvements. This facility is designed as an Extended Detention Basin (EDB) storm water quality facility with a full spectrum outlet box and associated forebay, micro pool, well screen, orifice plate, and 100-year outlet conveyance per the current drainage criteria manual. An IGA between CDOT and the Town of Monument will describe the ownership and maintenance responsibilities. The pond design allows for the required Water Quality Capture Volume with release through an orifice plate (Top of Micropool = 7004.50) and then the other storm events up to the 100 yr. event will be handled through a 6'x3' concrete outlet box (Top of box = 7010.00).

The following represents the required design for this facility (See Appendix):

**SWQ Pond**

Total tributary area: 11.84 ac.

Effective Imperviousness: 53.6%

	<u>Estimated</u>	<u>Provided</u>
Zone 1 (WQCV)	0.21 Ac.-ft.	0.21 Ac.-ft.
Zone 2 (EURV)	0.39 Ac.-ft.	0.39 Ac.-ft.
Zone 3 (100-yr.)	0.52 Ac.-ft.	0.24 Ac.-ft.
Total	1.12 Ac.-ft.	0.84 Ac.-ft.

Top of Micropool elev: 7004.50

6'x3' Conc. Outlet box with top of box height of 5.5' and exist. 36" RCP outfall pipe

Orifice Plate design: Four holes = 1-3/16" dia. spaced 16.5"

Calculations per MHFD-Detention\_v4.05 spreadsheet:

Pond Peak Design Release: **(Q<sub>2</sub> = 0.5 cfs, Q<sub>5</sub> = 4.6 cfs, Q<sub>100</sub> = 25.2 cfs)**

Pre-developed Release: **(Q<sub>2</sub> = 10 cfs, Q<sub>5</sub> = 14 cfs, Q<sub>100</sub> = 36 cfs)**

Please reference the IGA between CDOT and the Town of Monument for details on ownership and maintenance.



## **DRAINAGE CRITERIA**

Hydrologic calculations were performed using the Town of Monument Standards, which follow the City of Colorado Springs/El Paso County Drainage Criteria Manual, as revised in May 2014. The Rational Method was used to estimate storm water runoff anticipated from design storms for the 5 year and 100-year recurrence interval for local storm inlet and pipe facility sizing. Runoff Coefficients are based on the imperviousness of the particular land use and the hydrologic soil type in accordance with Table 6-6. The average rainfall intensity, by recurrence interval found in the Intensity-Duration-Frequency (IDF) curves in Figure 6-5. (See Appendix)

The UD-BMP spreadsheet (ver. 3.07) along with the MHFD-Detention spreadsheet (ver. 4.05) were used to calculate the required volume for the EURV and 100-year release. User input 1-hour precipitation values in the UD-Detention spreadsheet were taken from Table 6-2 Volume 1 Colorado Springs Drainage Criteria Manual.

## **FLOODPLAIN STATEMENT**

No portion of this site is located within a floodplain as determined by the Flood Insurance Rate Maps (F.I.R.M.) Map Number 08041C0278G effective date, December 7, 2018 (See Appendix).

## **SUMMARY**

Construction of these proposed public roadway improvements will not adversely affect the surrounding developments. All drainage facilities were sized using the current Drainage Criteria and will safely discharge storm water runoff to adequate outfalls. Developed flows will be routed to the proposed SWQ/detention facility within CDOT ROW and slowly released at historic rates. All existing downstream facilities will not be significantly affected upon the construction of these public improvements.

PREPARED BY:

**Classic Consulting Engineers & Surveyors, LLC**



Marc A. Whorton, P.E.  
Project Manager

maw/130222/Reports/FDR – MJ West Hwy 105-JCP.doc



## REFERENCES

1. City of Colorado Springs/County of El Paso Drainage Criteria Manual dated May 2014.
2. "Drainage Analysis Addendum No. 2 Village Center at Woodmoor", Classic Consulting Engineers and Surveyors, dated June 2009.
3. "Drainage Letter Amendment for the Drainage Analysis Addendum Village Center at Woodmoor", Classic Consulting Engineers and Surveyors, dated October 2010.
4. "Village Center @ Woodmoor Filing No.1" Berge-Brewer and Associates, Inc., dated January 2005.
5. "Drainage Basin Planning Study Dirty Woman Creek and Crystal Creek El Paso County," Kiowa Engineering Corporation, dated September 1993.
6. "MDDP for The Village" Classic Consulting, dated February 2020
7. "Final Drainage Report for Monument Junction East (Phase 1 PD Site Plan)", Classic Consulting, dated January 2022.
8. "Final Drainage Report for Monument Junction West Filing No. 1", Classic Consulting, dated March 2022.
9. "Preliminary Drainage Report – Highway 105 Project A for El Paso County", HDR, Inc., dated November 2021.



**APPENDIX**



**VICINITY MAP**

MONUMENT JUNCTION DEVELOPMENT  
HIGHWAY 105 / JACKSON CREEK PKWY.  
INTERSECTION IMPROVEMENTS  
VICINITY MAP



SITE

MONUMENT  
JUNCTION WEST

MONUMENT  
JUNCTION EAST

Ronald Reagan Hwy

Jackson Creek Pkwy

Villa Grove

Paula Cir

Red Mica Way

Quarry Way

Knollwood Dr

Water Flume Way

Bowstring Rd



**SOILS MAP (S.C.S SURVEY)**





Soil Map—El Paso County Area, Colorado

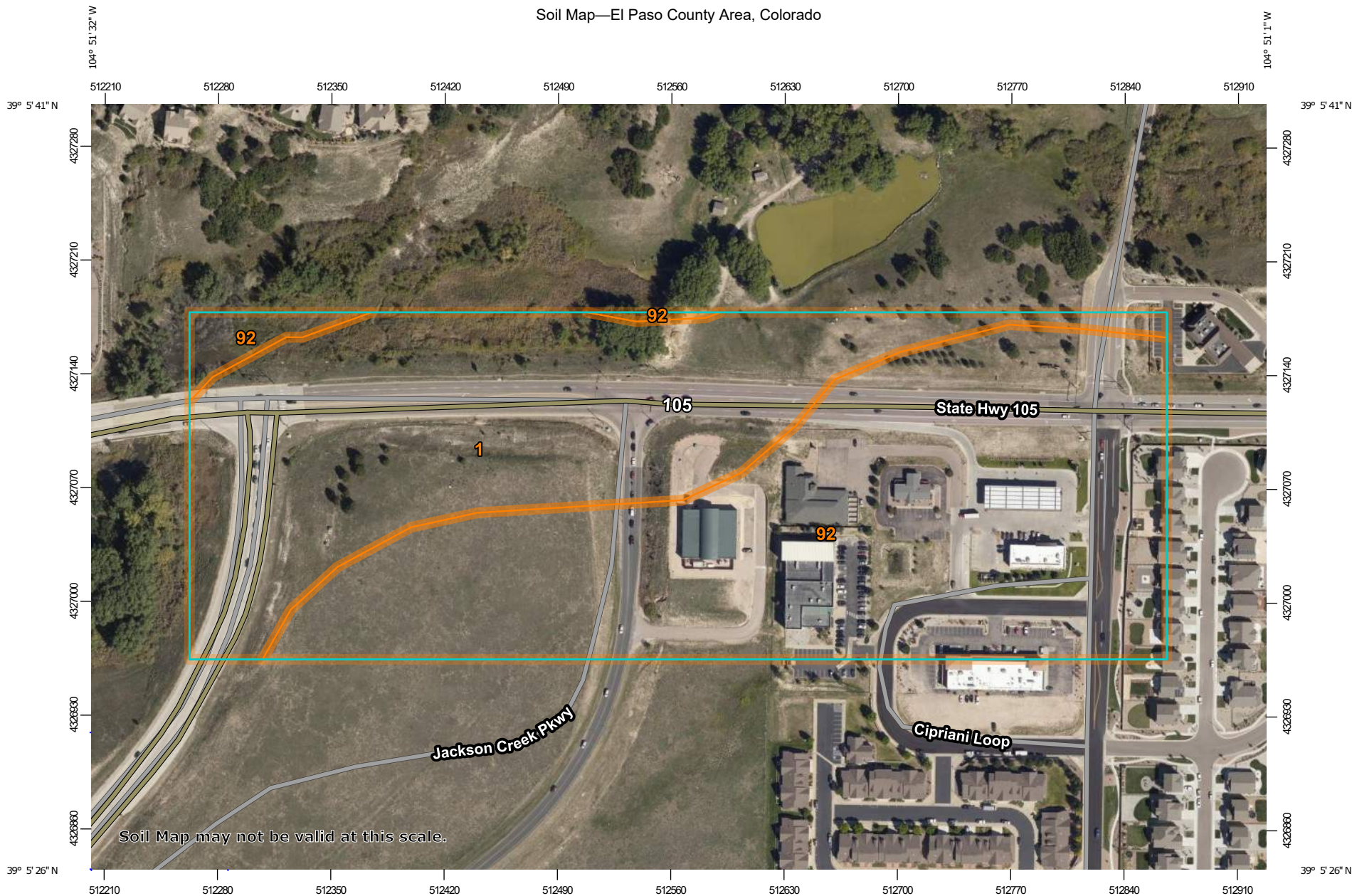

Map Scale: 1:3,320 if printed on A landscape (11" x 8.5") sheet.

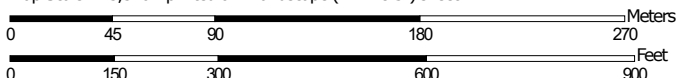

Map projection: Web Mercator Corner coordinates: WGS84 Edge ticks: UTM Zone 13N WGS84



## MAP LEGEND

### Area of Interest (AOI)

Area of Interest (AOI)

### Soils

 Soil Map Unit Polygons

 Soil Map Unit Lines

 Soil Map Unit Points

### Special Point Features



Blowout



Borrow Pit



Clay Spot



Closed Depression



Gravel Pit



Gravelly Spot



Landfill



Lava Flow



Marsh or swamp



Mine or Quarry



Miscellaneous Water



Perennial Water



Rock Outcrop



Saline Spot



Sandy Spot



Severely Eroded Spot



Sinkhole



Slide or Slip



Sodic Spot



Spoil Area



Stony Spot



Very Stony Spot



Wet Spot



Other



Special Line Features

### Water Features



Streams and Canals

### Transportation



Rails



Interstate Highways



US Routes



Major Roads



Local Roads

### Background



Aerial Photography

## MAP INFORMATION

The soil surveys that comprise your AOI were mapped at 1:24,000.

**Warning:** Soil Map may not be valid at this scale.

Enlargement of maps beyond the scale of mapping can cause misunderstanding of the detail of mapping and accuracy of soil line placement. The maps do not show the small areas of contrasting soils that could have been shown at a more detailed scale.

Please rely on the bar scale on each map sheet for map measurements.

Source of Map: Natural Resources Conservation Service  
Web Soil Survey URL:  
Coordinate System: Web Mercator (EPSG:3857)

Maps from the Web Soil Survey are based on the Web Mercator projection, which preserves direction and shape but distorts distance and area. A projection that preserves area, such as the Albers equal-area conic projection, should be used if more accurate calculations of distance or area are required.

This product is generated from the USDA-NRCS certified data as of the version date(s) listed below.

Soil Survey Area: El Paso County Area, Colorado  
Survey Area Data: Version 19, Aug 31, 2021

Soil map units are labeled (as space allows) for map scales 1:50,000 or larger.

Date(s) aerial images were photographed: Aug 19, 2018—Sep 23, 2018

The orthophoto or other base map on which the soil lines were compiled and digitized probably differs from the background imagery displayed on these maps. As a result, some minor shifting of map unit boundaries may be evident.

## Map Unit Legend

Map Unit Symbol	Map Unit Name	Acres in AOI	Percent of AOI
1	Alamosa loam, 1 to 3 percent slopes	13.3	41.7%
92	Tomah-Crowfoot loamy sands, 3 to 8 percent slopes	18.6	58.3%
<b>Totals for Area of Interest</b>		<b>32.0</b>	<b>100.0%</b>

## El Paso County Area, Colorado

### 1—Alamosa loam, 1 to 3 percent slopes

#### Map Unit Setting

*National map unit symbol:* 3670

*Elevation:* 7,200 to 7,700 feet

*Farmland classification:* Prime farmland if irrigated and reclaimed of excess salts and sodium

#### Map Unit Composition

*Alamosa and similar soils:* 85 percent

*Estimates are based on observations, descriptions, and transects of the mapunit.*

#### Description of Alamosa

##### Setting

*Landform:* Flood plains, fans

*Down-slope shape:* Linear

*Across-slope shape:* Linear

*Parent material:* Alluvium

##### Typical profile

*A - 0 to 6 inches:* loam

*Bt - 6 to 14 inches:* clay loam

*Btk - 14 to 33 inches:* clay loam

*Cg1 - 33 to 53 inches:* sandy clay loam

*Cg2 - 53 to 60 inches:* sandy loam

##### Properties and qualities

*Slope:* 1 to 3 percent

*Depth to restrictive feature:* More than 80 inches

*Drainage class:* Poorly drained

*Runoff class:* Very high

*Capacity of the most limiting layer to transmit water*

*(Ksat):* Moderately high (0.20 to 0.60 in/hr)

*Depth to water table:* About 12 to 18 inches

*Frequency of flooding:* FrequentNone

*Frequency of ponding:* None

*Calcium carbonate, maximum content:* 5 percent

*Maximum salinity:* Very slightly saline to strongly saline (2.0 to 16.0 mmhos/cm)

*Available water supply, 0 to 60 inches:* High (about 10.2 inches)

##### Interpretive groups

*Land capability classification (irrigated):* None specified

*Land capability classification (nonirrigated):* 5w

*Hydrologic Soil Group:* D

*Ecological site:* R048AY241CO - Mountain Meadow

*Hydric soil rating:* Yes

### **Minor Components**

#### **Other soils**

*Percent of map unit:*

*Hydric soil rating:* No

### **Data Source Information**

Soil Survey Area: El Paso County Area, Colorado

Survey Area Data: Version 19, Aug 31, 2021

## El Paso County Area, Colorado

### 92—Tomah-Crowfoot loamy sands, 3 to 8 percent slopes

#### Map Unit Setting

*National map unit symbol:* 36b9

*Elevation:* 7,300 to 7,600 feet

*Farmland classification:* Not prime farmland

#### Map Unit Composition

*Tomah and similar soils:* 50 percent

*Crowfoot and similar soils:* 30 percent

*Estimates are based on observations, descriptions, and transects of the mapunit.*

#### Description of Tomah

##### Setting

*Landform:* Hills, alluvial fans

*Landform position (three-dimensional):* Side slope, crest

*Down-slope shape:* Linear

*Across-slope shape:* Linear

*Parent material:* Alluvium derived from arkose and/or residuum weathered from arkose

##### Typical profile

*A - 0 to 10 inches:* loamy sand

*E - 10 to 22 inches:* coarse sand

*Bt - 22 to 48 inches:* stratified coarse sand to sandy clay loam

*C - 48 to 60 inches:* coarse sand

##### Properties and qualities

*Slope:* 3 to 8 percent

*Depth to restrictive feature:* More than 80 inches

*Drainage class:* Well drained

*Runoff class:* Medium

*Capacity of the most limiting layer to transmit water*

*(Ksat):* Moderately high to high (0.60 to 2.00 in/hr)

*Depth to water table:* More than 80 inches

*Frequency of flooding:* None

*Frequency of ponding:* None

*Available water supply, 0 to 60 inches:* Low (about 4.6 inches)

##### Interpretive groups

*Land capability classification (irrigated):* None specified

*Land capability classification (nonirrigated):* 4e

*Hydrologic Soil Group:* B

*Ecological site:* R049XY216CO - Sandy Divide

*Hydric soil rating:* No

## Description of Crowfoot

### Setting

*Landform:* Alluvial fans, hills  
*Landform position (three-dimensional):* Side slope, crest  
*Down-slope shape:* Linear  
*Across-slope shape:* Linear  
*Parent material:* Alluvium

### Typical profile

*A - 0 to 12 inches:* loamy sand  
*E - 12 to 23 inches:* sand  
*Bt - 23 to 36 inches:* sandy clay loam  
*C - 36 to 60 inches:* coarse sand

### Properties and qualities

*Slope:* 3 to 8 percent  
*Depth to restrictive feature:* More than 80 inches  
*Drainage class:* Well drained  
*Runoff class:* Medium  
*Capacity of the most limiting layer to transmit water (Ksat):* Moderately high to high (0.60 to 2.00 in/hr)  
*Depth to water table:* More than 80 inches  
*Frequency of flooding:* None  
*Frequency of ponding:* None  
*Available water supply, 0 to 60 inches:* Low (about 4.7 inches)

### Interpretive groups

*Land capability classification (irrigated):* None specified  
*Land capability classification (nonirrigated):* 4e  
*Hydrologic Soil Group:* B  
*Ecological site:* R049XY216CO - Sandy Divide  
*Hydric soil rating:* No

## Minor Components

### Other soils

*Percent of map unit:*  
*Hydric soil rating:* No

### Pleasant

*Percent of map unit:*  
*Landform:* Depressions  
*Hydric soil rating:* Yes

## Data Source Information

Soil Survey Area: El Paso County Area, Colorado  
Survey Area Data: Version 19, Aug 31, 2021

**F.E.M.A. MAP**





**NOTES TO USERS**

This map is for use in administering the National Flood Insurance Program. It does not necessarily identify all areas subject to flooding, particularly from local drainage sources of small size. The community map repository should be consulted for possible updated or additional flood hazard information.

To obtain more detailed information in areas where Base Flood Elevations (BFEs) and/or floodways have been determined, users are encouraged to consult the Flood Profiles and Floodway Data and/or Summary of Stillwater Elevations tables contained within the Flood Insurance Study (FIS) report that accompanies this FIRM. Users should be aware that BFEs shown on the FIRM represent rounded whole-foot elevations. These BFEs are intended for flood insurance rating purposes only and should not be used as the sole source of flood elevation information. Accordingly, flood elevation data presented in the FIS report should be utilized in conjunction with the FIRM for purposes of construction and/or floodplain management.

Coastal Base Flood Elevations shown on this map apply only landward of 0.0' North American Vertical Datum of 1988 (NAVD88). Users of this FIRM should be aware that coastal flood elevations are also provided in the Summary of Stillwater Elevations table in the Flood Insurance Study report for this jurisdiction. Elevations shown in the Summary of Stillwater Elevations table should be used for construction and/or floodplain management purposes when they are higher than the elevations shown on this FIRM.

Boundaries of the floodways were computed at cross sections and interpolated between cross sections. The floodways were based on hydraulic considerations with regard to requirements of the National Flood Insurance Program. Floodway widths and other pertinent floodway data are provided in the Flood Insurance Study report for this jurisdiction.

Certain areas not in Special Flood Hazard Areas may be protected by flood control structures. Refer to section 2.4 "Flood Protection Measures" of the Flood Insurance Study report for information on flood control structures for this jurisdiction.

The projection used in the preparation of this map was Universal Transverse Mercator (UTM) zone 13. The horizontal datum was NAD83, GRS80 spheroid. Differences in datum, spheroid, projection or UTM zones zones used in the production of FIRMs for adjacent jurisdictions may result in slight positional differences in map features across jurisdiction boundaries. These differences do not affect the accuracy of this FIRM.

Flood elevations on this map are referenced to the North American Vertical Datum of 1988 (NAVD88). These flood elevations must be compared to structure and ground elevations referenced to the same vertical datum. For information regarding conversion between the National Geodetic Vertical Datum of 1929 and the North American Vertical Datum of 1988, visit the National Geodetic Survey website at <http://www.ngs.noaa.gov/> or contact the National Geodetic Survey at the following address:

NGS Information Services  
NOAA, NUNCS12  
National Geodetic Survey  
SSMC-3, #9202  
1315 East-West Highway  
Silver Spring, MD 20910-3282

To obtain current elevation, description, and/or location information for bench marks shown on this map, please contact the Information Services Branch of the National Geodetic Survey at (301) 713-3242 or visit its website at <http://www.ngs.noaa.gov/>.

Base Map information shown on this FIRM was provided in digital format by El Paso County, Colorado Springs Utilities, City of Fountain, Bureau of Land Management, National Oceanic and Atmospheric Administration, United States Geological Survey, and Anderson Consulting Engineers, Inc. These data are current as of 2006.

This map reflects more detailed and up-to-date stream channel configurations and floodplain delineations than those shown on the previous FIRM for this jurisdiction. The floodplains and floodways that were transferred from the previous FIRM may have been adjusted to conform to these new stream channel configurations. As a result, the Flood Profiles and Floodway Data tables in the Flood Insurance Study Report (which contains authoritative hydraulic data) may reflect stream channel distances that differ from what is shown on this map. The profile baselines depicted on this map represent the hydraulic modeling baselines that match the flood profiles and Floodway Data Tables if applicable, in the FIS report. As a result, the profile baselines may deviate significantly from the new base map channel representation and may appear outside of the floodplain.

Corporate limits shown on this map are based on the best data available at the time of publication. Because changes due to annexations or de-annexations may have occurred after this map was published, map users should contact appropriate community officials to verify current corporate limit locations.

Please refer to the separately printed Map Index for an overview map of the county showing the layout of map panels; community map repository addresses; and a Listing of Communities table containing National Flood Insurance Program dates for each community as well as a listing of the panels on which each community is located.

Contact FEMA Map Service Center (MSC) via the FEMA Map Information eXchange (FMIX) 1-877-336-2627 for information on available products associated with this FIRM. Available products may include previously issued Letters of Map Change, a Flood Insurance Study Report, and/or digital versions of this map. The MSC may also be reached by Fax at 1-800-358-9620 and its website at <http://www.msc.fema.gov/>.

If you have questions about this map or questions concerning the National Flood Insurance Program in general, please call 1-877-FEMA MAP (1-877-336-2627) or visit the FEMA website at <http://www.fema.gov/business/nfp>.

**El Paso County Vertical Datum Offset Table**

Flooding Source	Vertical Datum Offset (ft)
REFER TO SECTION 3.3 OF THE EL PASO COUNTY FLOOD INSURANCE STUDY FOR STREAM BY STREAM VERTICAL DATUM CONVERSION INFORMATION	

**Panel Location Map**

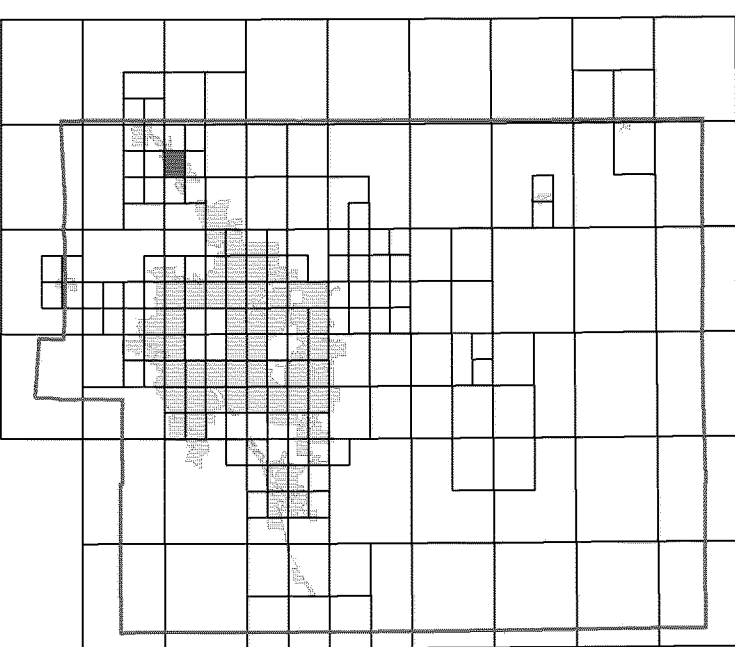

This Digital Flood Insurance Rate Map (DFIRM) was produced through a Cooperating Technical Partner (CTP) agreement between the State of Colorado Water Conservation Board (CWCB) and the Federal Emergency Management Agency (FEMA).



Additional Flood Hazard information and resources are available from local communities and the Colorado Water Conservation Board.

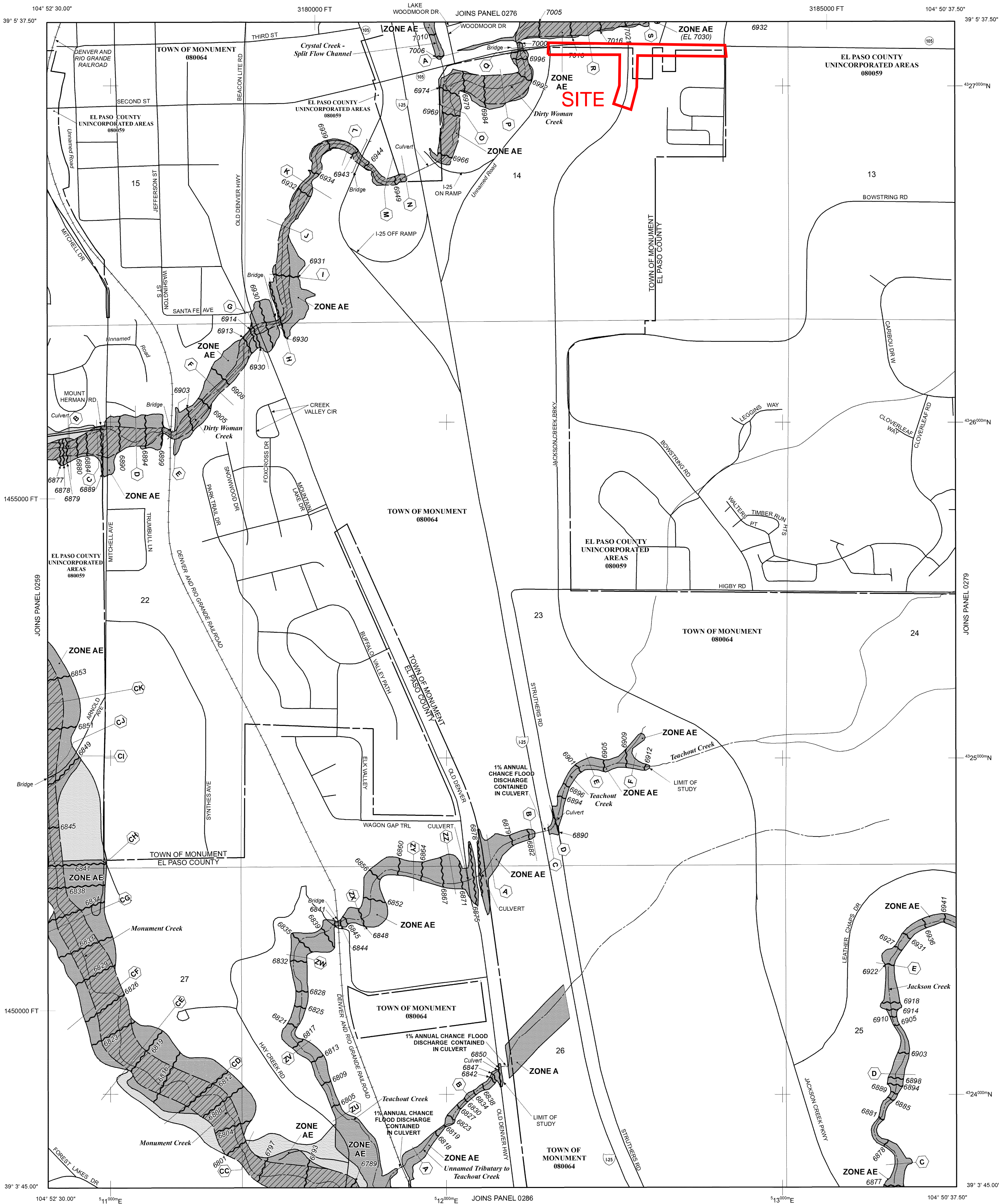

NOTE: MAP AREA SHOWN ON THIS PANEL IS LOCATED WITHIN TOWNSHIP 11 SOUTH, RANGE 67 WEST.

**LEGEND**

- SPECIAL FLOOD HAZARD AREAS (SFHAs) SUBJECT TO INUNDATION BY THE 1% ANNUAL CHANCE FLOOD
- ZONE A** No Base Flood Elevations determined. Base Flood Elevations determined.
- ZONE AE** Flood depths of 1 to 3 feet (usually areas of ponding); Base Flood Elevations determined.
- ZONE AH** Flood depths of 1 to 3 feet (usually sheet flow on sloping terrain); average depths determined. For areas of alluvial fan flooding, velocities also determined.
- ZONE AR** Special Flood Hazard Area Formerly protected from the 1% annual chance flood by a flood control system that was subsequently decertified. Zone AR indicates that the former flood control system is being restored to provide protection from the 1% annual chance or greater flood.
- ZONE A99** Area to be protected from 1% annual chance flood by a Federal flood protection system under construction; no Base Flood Elevations determined.
- ZONE V** Coastal flood zone with velocity hazard (wave action); no Base Flood Elevations determined.
- ZONE VE** Coastal flood zone with velocity hazard (wave action); Base Flood Elevations determined.
- FLOODWAY AREAS IN ZONE AE
- OTHER FLOOD AREAS
- ZONE X** Areas of 0.2% annual chance flood; areas of 1% annual chance flood with average depths of less than 1 foot, or with drainage areas less than 1 square mile; and areas protected by levees from 1% annual chance flood.
- OTHER AREAS
- ZONE D** Areas determined to be outside the 0.2% annual chance floodplain. Areas in which flood hazards are undetermined, but possible.
- COASTAL BARRIER RESOURCES SYSTEM (CBRS) AREAS
- OTHERWISE PROTECTED AREAS (OPAs)

CBRS areas and OPAs are normally located within or adjacent to Special Flood Hazard Areas.

- Floodplain boundary
- Floodway boundary
- Zone D Boundary
- CBRS and OPA boundary
- Boundary dividing Special Flood Hazard Areas of different Base Flood Elevations, flood depths or flood velocities.
- Base Flood Elevation line and value; elevation in feet\* (EL 987)

\* Referenced to the North American Vertical Datum of 1988 (NAVD 88)

- Cross section line
- Transect line
- Geographic coordinates referenced to the North American Datum of 1983 (NAD 83)
- 1000-meter Universal Transverse Mercator grid ticks, zone 13
- 5000-foot grid ticks; Colorado State Plane coordinate system, central zone (FIPS/CONIC 5002), Lambert Conformal Conic Projection
- Bench mark (see explanation in Notes to Users section of this FIRM panel)
- River Mile

MAP REPOSITORIES  
Refer to Map Repositories list on Map Index

EFFECTIVE DATE OF COUNTYWIDE FLOOD INSURANCE RATE MAP  
**MARCH 17, 1997**

EFFECTIVE DATE(S) OF REVISION(S) TO THIS PANEL  
**DECEMBER 7, 2018** to update corporate limits, to change Base Flood Elevations and Special Flood Hazard Areas, to update map format, to add roads and road names, and to incorporate previously revised Letters of Map Revision.

For community map revision history prior to countywide mapping, refer to the Community Map History Table located in the Flood Insurance Study report for this jurisdiction.

To determine if flood insurance is available in this community, contact your insurance agent or call the National Flood Insurance Program at 1-800-638-6620.

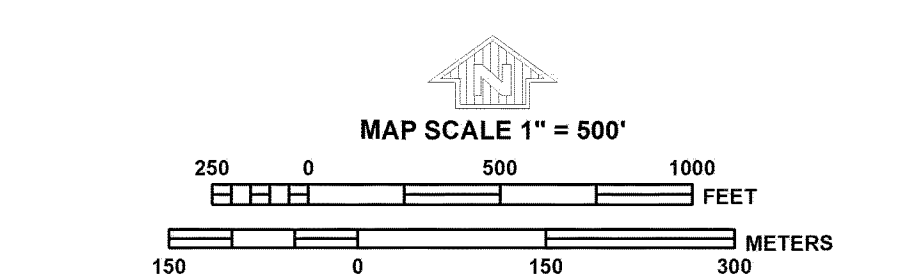

**NFIP**

**PANEL 0278G**

---

**FIRM**  
FLOOD INSURANCE RATE MAP  
**EL PASO COUNTY, COLORADO AND INCORPORATED AREAS**

**PANEL 278 OF 1300**  
(SEE MAP INDEX FOR FIRM PANEL LAYOUT)

CONTAINS:

COMMUNITY	NUMBER	PANEL	SUFFIX
EL PASO COUNTY	08009	0278	G
MONUMENT, TOWN OF	08004	0278	G

Notice: This map was reissued on 05/15/2020 to make a correction. This version replaces any previous versions. See the Notice-to-User Letter that accompanied this correction for details.

Notice to User: The Map Number shown below should be used when placing map orders. The Community Number shown above should be used on insurance applications for the subject community.

**MAP NUMBER**  
**08041C0278G**

**MAP REVISED**  
**DECEMBER 7, 2018**

Federal Emergency Management Agency

**JURISDICTIONAL DETERMINATION**



**DEPARTMENT OF THE ARMY**  
CORPS OF ENGINEERS, ALBUQUERQUE DISTRICT  
SOUTHERN COLORADO REGULATORY BRANCH  
201 WEST 8TH STREET, SUITE 350  
PUEBLO, COLORADO 81003

June 23, 2022

Regulatory Division

SUBJECT: Jurisdictional Determination- Action No.SPA-2022-00180

Classic Communities  
Attn: Steve Schlosser  
2138 Flying Horse Club Drive  
Colorado Springs, Colorado 80921  
[sschlosser@classichomes.com](mailto:sschlosser@classichomes.com)

Dear Mr. Schlosser:

This letter responds to your request for a jurisdictional determination (JD) for multiple aquatic resources associated with the Monument Junction-Highway 105 improvement Project. The project site is located near Dirty Woman Creek, centered at latitude 39.092991°, longitude -104.856431°, Colorado Springs, El Paso County, Colorado. We have assigned Action No. SPA-2022-00180 to your request. Please reference this number in all future correspondence concerning the site.

Based on the information provided, we concur with your aquatic resource delineation for the site, as depicted on the enclosed drawing labeled, *SPA-2022-00180, Figure 1*, prepared by Core Consultants, Inc. (enclosure 1). We have determined that the site does not contain waters of the United States that are subject to regulation under Section 404 of the Clean Water Act. The aquatic resources identified as *WT-A1 (0.169 acres)*, *WT-A2 (0.006 acre)*, *ST-A1 (0.003 acre)*, *ST-A2 (0.001 acre)*, *ST-A3 (0.001 acre)*, and *ST-A4 (0.001 acre)*, on the above drawing are man-made wetland and ditch features that were constructed in uplands, drain only uplands, and do not have relatively permanent flow. As such, these aquatic resources are not regulated by the U.S. Army Corps of Engineers. This disclaimer of jurisdiction is only for Section 404 of the Federal Clean Water Act.

We are enclosing a copy of the *Approved Jurisdictional Determination Form* for your site (enclosure 2). A copy of this JD is also available at <http://www.spa.usace.army.mil/req/JD>. This approved JD is valid for five years unless new information warrants revision of the determination before the expiration date.

You may accept or appeal this approved JD or provide new information in accordance with the attached Notification of Administration Appeal Options and Process and Request for Appeal (NAAOP-RFA) (enclosure 3). If you elect to appeal this approved JD, you must complete Section II of the form and return it to the Army Engineer Division, South Pacific, CESPDPDS-O, Attn: Tom Cavanaugh, Administrative

Appeal Review Officer, P.O. Box 36023, 450 Golden Gate Ave, San Francisco, CA 94102 within 60 days of the date of this notice. Failure to notify the Corps within 60 days of the date of this notice means that you accept the approved JD in its entirety and waive all rights to appeal the approved JD.

If you have any questions, please contact Senior Project Manager Kyle Zibung by email at [kyle.d.zibung@usace.army.mil](mailto:kyle.d.zibung@usace.army.mil), or telephone at (651) 290-5877. For program information or to complete our Customer Survey, visit our website at <https://www.spa.usace.army.mil/Missions/Regulatory-Program-and-Permits/>.

Sincerely,

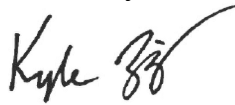
A handwritten signature in black ink that reads "Kyle Zibung". The signature is written in a cursive style with a large, sweeping flourish at the end.

Kyle Zibung  
Senior Project Manager  
Southern Colorado Branch

Enclosures

cc:

Natalie Graves, Core Consultants, Inc. ([ngraves@liveyourcore.com](mailto:ngraves@liveyourcore.com))

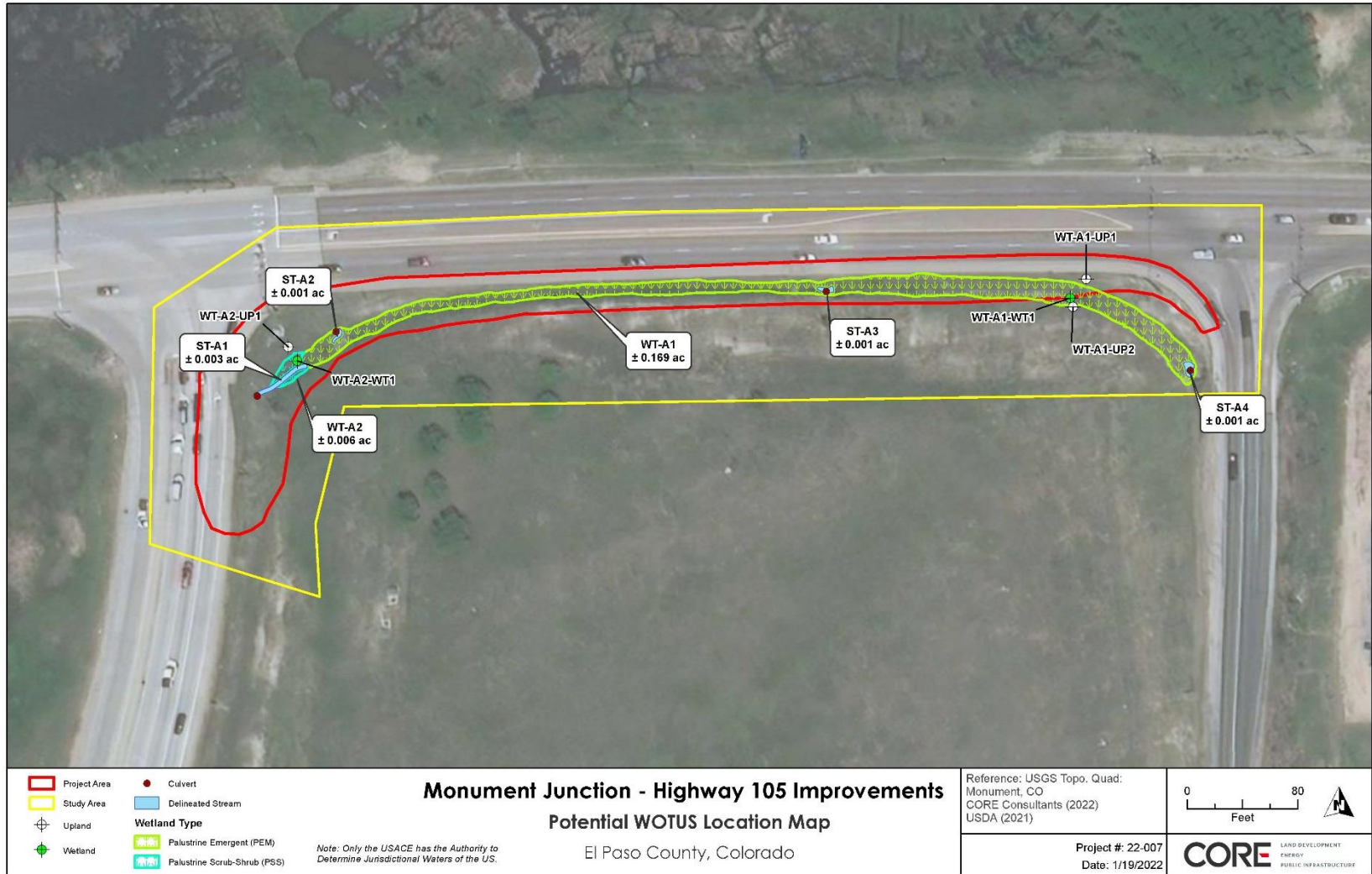

Figure 4.4 Potential WOTUS Location Map

## NOTIFICATION OF ADMINISTRATIVE APPEAL OPTIONS AND PROCESS AND REQUEST FOR APPEAL

Applicant: Classic Communities c/o Steve Schlosser	File No.: SPA-2022-00180	Date: June 23, 2022
Attached is:		See Section below
	INITIAL PROFFERED PERMIT (Standard Permit or Letter of permission)	A
	PROFFERED PERMIT (Standard Permit or Letter of permission)	B
	PERMIT DENIAL	C
→	APPROVED JURISDICTIONAL DETERMINATION	D
	PRELIMINARY JURISDICTIONAL DETERMINATION	E

**SECTION I** - The following identifies your rights and options regarding an administrative appeal of the above decision. Additional information may be found at [http://www.usace.army.mil/cecw/pages/reg\\_materials.aspx](http://www.usace.army.mil/cecw/pages/reg_materials.aspx) or Corps regulations at 33 CFR Part 331.

**A: INITIAL PROFFERED PERMIT:** You may accept or object to the permit.

- **ACCEPT:** If you received a Standard Permit, you may sign the permit document and return it to the district engineer for final authorization. If you received a Letter of Permission (LOP), you may accept the LOP and your work is authorized. Your signature on the Standard Permit or acceptance of the LOP means that you accept the permit in its entirety, and waive all rights to appeal the permit, including its terms and conditions, and approved jurisdictional determinations associated with the permit.
- **OBJECT:** If you object to the permit (Standard or LOP) because of certain terms and conditions therein, you may request that the permit be modified accordingly. You must complete Section II of this form and return the form to the district engineer. Your objections must be received by the district engineer within 60 days of the date of this notice, or you will forfeit your right to appeal the permit in the future. Upon receipt of your letter, the district engineer will evaluate your objections and may: (a) modify the permit to address all of your concerns, (b) modify the permit to address some of your objections, or (c) not modify the permit having determined that the permit should be issued as previously written. After evaluating your objections, the district engineer will send you a proffered permit for your reconsideration, as indicated in Section B below.

**B: PROFFERED PERMIT:** You may accept or appeal the permit

- **ACCEPT:** If you received a Standard Permit, you may sign the permit document and return it to the district engineer for final authorization. If you received a Letter of Permission (LOP), you may accept the LOP and your work is authorized. Your signature on the Standard Permit or acceptance of the LOP means that you accept the permit in its entirety, and waive all rights to appeal the permit, including its terms and conditions, and approved jurisdictional determinations associated with the permit.
- **APPEAL:** If you choose to decline the proffered permit (Standard or LOP) because of certain terms and conditions therein, you may appeal the declined permit under the Corps of Engineers Administrative Appeal Process by completing Section II of this form and sending the form to the division engineer (address on reverse). This form must be received by the division engineer within 60 days of the date of this notice.

**C: PERMIT DENIAL:** You may appeal the denial of a permit under the Corps of Engineers Administrative Appeal Process by completing Section II of this form and sending the form to the division engineer (address on reverse). This form must be received by the division engineer within 60 days of the date of this notice.

**D: APPROVED JURISDICTIONAL DETERMINATION:** You may accept or appeal the approved JD or provide new information.

- **ACCEPT:** You do not need to notify the Corps to accept an approved JD. Failure to notify the Corps within 60 days of the date of this notice, means that you accept the approved JD in its entirety, and waive all rights to appeal the approved JD.
- **APPEAL:** If you disagree with the approved JD, you may appeal the approved JD under the Corps of Engineers Administrative Appeal Process by completing Section II of this form and sending the form to the division engineer (address on reverse). This form must be received by the division engineer within 60 days of the date of this notice.

**E: PRELIMINARY JURISDICTIONAL DETERMINATION:** You do not need to respond to the Corps regarding the preliminary JD. The Preliminary JD is not appealable. If you wish, you may request an approved JD (which may be appealed), by contacting the Corps district for further instruction. Also you may provide new information for further consideration by the Corps to reevaluate the JD.

**SECTION II - REQUEST FOR APPEAL or OBJECTIONS TO AN INITIAL PROFFERED PERMIT**

**REASONS FOR APPEAL OR OBJECTIONS:** (Describe your reasons for appealing the decision or your objections to an initial proffered permit in clear concise statements. You may attach additional information to this form to clarify where your reasons or objections are addressed in the administrative record.)

**ADDITIONAL INFORMATION:** The appeal is limited to a review of the administrative record, the Corps memorandum for the record of the appeal conference or meeting, and any supplemental information that the review officer has determined is needed to clarify the administrative record. Neither the appellant nor the Corps may add new information or analyses to the record. However, you may provide additional information to clarify the location of information that is already in the administrative record.

**POINT OF CONTACT FOR QUESTIONS OR INFORMATION:**

If you have questions regarding this decision and/or the appeal process you may contact:

Kyle Zibung  
U.S. Army Corps of Engineers  
201 West 8th Street, Suite 350  
Pueblo, Colorado 81003

Phone: 651-290-5877  
Email: [kyle.d.zibung@usace.army.mil](mailto:kyle.d.zibung@usace.army.mil)

If you only have questions regarding the appeal process you may also contact:

Thomas J. Cavanaugh  
Administrative Appeal Review Officer  
U.S. Army Corps of Engineers  
South Pacific Division  
P.O. Box 36023, 450 Golden Gate Ave  
San Francisco, California 94102  
Phone: 415-503-6574, FAX:415-503-6646  
Email: [Thomas.J.Cavanaugh@usace.army.mil](mailto:Thomas.J.Cavanaugh@usace.army.mil)

**RIGHT OF ENTRY:** Your signature below grants the right of entry to Corps of Engineers personnel, and any government consultants, to conduct investigations of the project site during the course of the appeal process. You will be provided a 15 day notice of any site investigation and will have the opportunity to participate in all site investigations.

\_\_\_\_\_  
Signature of appellant or agent.

Date:

Telephone number:

**APPROVED JURISDICTIONAL DETERMINATION FORM**  
**U.S. Army Corps of Engineers**

This form should be completed by following the instructions provided in Section IV of the JD Form Instructional Guidebook.

**SECTION I: BACKGROUND INFORMATION**

**A. REPORT COMPLETION DATE FOR APPROVED JURISDICTIONAL DETERMINATION (JD): June 23, 2022**

**B. ST PAUL, MN DISTRICT OFFICE, FILE NAME, AND NUMBER: SPA-2022-00180, Classic Communities Highway 105 AJD**

**C. PROJECT LOCATION AND BACKGROUND INFORMATION:**

State: Colorado County/parish/borough: El Paso County City: Monument

Center coordinates of site (lat/long in degree decimal format): Lat. 39.092991° N, Long. -104.856431° W.

Universal Transverse Mercator: 15

Name of nearest waterbody:

Name of watershed or Hydrologic Unit Code (HUC): 07020007

- Check if map/diagram of review area and/or potential jurisdictional areas is/are available upon request.  
 Check if other sites (e.g., offsite mitigation sites, disposal sites, etc...) are associated with this action and are recorded on a different JD form.

**D. REVIEW PERFORMED FOR SITE EVALUATION (CHECK ALL THAT APPLY):**

- Office (Desk) Determination. Date: June 22, 2022  
 Field Determination. Date(s): June 8, 2022

**SECTION II: SUMMARY OF FINDINGS**

**A. RHA SECTION 10 DETERMINATION OF JURISDICTION.**

There are no "navigable waters of the U.S." within Rivers and Harbors Act (RHA) jurisdiction (as defined by 33 CFR part 329) in the review area.

**B. CWA SECTION 404 DETERMINATION OF JURISDICTION.**

There are no "waters of the U.S." within Clean Water Act (CWA) jurisdiction (as defined by 33 CFR part 328) in the review area.

1. Waters of the U.S.: N/A

2. Non-regulated waters/wetlands (check if applicable):<sup>1</sup>

Potentially jurisdictional waters and/or wetlands were assessed within the review area and determined to be not jurisdictional. Explain: **The review area for this determination is comprised of two linear wetlands labeled as WT-A1 (0.169 acres) and WT-A2 (0.006 acre) and four linear stream segments labeled as ST-A1 (0.003 acre), ST-A2 (0.001 acre), ST-A3 (0.001 acre), and ST-A4 (0.001 acre) in the February 2022, Core Consultants, Inc. Wetland Delineation Report. In 2005, the entire review area was graded for roadway improvements to Highway 105 and the I-25 interchange, thereby creating all six linear aquatic resources evaluated by this determination. Based on an analysis of multiple years of aerial photography, USDA web soil survey data, USGS topographic maps, USGS NHD, NWI mapping, February 2022, Core Consultants, Inc. Wetland Delineation Report, and a June 22, 2002 site visit, the Corps has determined that all six aquatic resources are linear roadside drainage features constructed in uplands during grading for the Highway 105 and the I-25 interchange projects. In accordance with Corps Regulations at 33 CFR Part 328.3(b) and associated Rapanos Guidance, the aforementioned aquatic features are not within the Corps jurisdiction because they were constructed in uplands, drain only uplands, and do not have relatively permanent flow.**

**SECTION III: CWA ANALYSIS**

**A. TNWs AND WETLANDS ADJACENT TO TNWs: N/A**

**B. CHARACTERISTICS OF TRIBUTARY (THAT IS NOT A TNW) AND ITS ADJACENT WETLANDS (IF ANY): N/A**

**C. SIGNIFICANT NEXUS DETERMINATION: N/A**

**D. DETERMINATIONS OF JURISDICTIONAL FINDINGS. THE SUBJECT WATERS/WETLANDS ARE (CHECK ALL THAT APPLY): N/A**

<sup>1</sup> Supporting documentation is presented in Section III.F.



**E. ISOLATED [INTERSTATE OR INTRA-STATE] WATERS, INCLUDING ISOLATED WETLANDS, THE USE, DEGRADATION OR DESTRUCTION OF WHICH COULD AFFECT INTERSTATE COMMERCE, INCLUDING ANY SUCH WATERS (CHECK ALL THAT APPLY): N/A**

**F. NON-JURISDICTIONAL WATERS, INCLUDING WETLANDS (CHECK ALL THAT APPLY):**

- If potential wetlands were assessed within the review area, these areas did not meet the criteria in the 1987 Corps of Engineers Wetland Delineation Manual and/or appropriate Regional Supplements.
- Review area included isolated waters with no substantial nexus to interstate (or foreign) commerce.
  - Prior to the Jan 2001 Supreme Court decision in “*SWANCC*,” the review area would have been regulated based solely on the “Migratory Bird Rule” (MBR).
- Waters do not meet the “Significant Nexus” standard, where such a finding is required for jurisdiction. Explain:
- Other (explain, if not covered above):

Provide acreage estimates for non-jurisdictional waters in the review area, where the sole potential basis of jurisdiction is the MBR factors (i.e., presence of migratory birds, presence of endangered species, use of water for irrigated agriculture), using best professional judgment (check all that apply):

- Non-wetland waters (i.e., rivers, streams):      linear feet      width (ft).
- Lakes/ponds:      acres.
- Other non-wetland waters:      acres. List type of aquatic resource:      .
- Wetlands:      acres.

Provide acreage estimates for non-jurisdictional waters in the review area that do not meet the “Significant Nexus” standard, where such a finding is required for jurisdiction (check all that apply):

- Non-wetland waters (i.e., rivers, streams):      linear feet,      width (ft).
- Lakes/ponds:      acres.
- Other non-wetland waters:      acres. List type of aquatic resource:      .
- Wetlands:      acres.

**SECTION IV: DATA SOURCES.**

**A. SUPPORTING DATA. Data reviewed for JD (check all that apply - checked items shall be included in case file and, where checked and requested, appropriately reference sources below):**

- Maps, plans, plots or plat submitted by or on behalf of the applicant/consultant: February 2022, Core Consultants, Inc.

**Wetland Delineation Report**

- Data sheets prepared/submitted by or on behalf of the applicant/consultant.
  - Office concurs with data sheets/delineation report.
  - Office does not concur with data sheets/delineation report.
- Data sheets prepared by the Corps:
- Corps navigable waters’ study:
- U.S. Geological Survey Hydrologic Atlas:
  - USGS NHD data.
  - USGS 8 and 12 digit HUC maps.
- U.S. Geological Survey map(s). Cite scale & quad name: 1:24k-Monument
- USDA Natural Resources Conservation Service Soil Survey. Citation: Web Soil Survey
- National wetlands inventory map(s). Cite name: National Wetland Inventory
- State/Local wetland inventory map(s):
- FEMA/FIRM maps:
- 100-year Floodplain Elevation is:      (National Geodetic Vertical Datum of 1929)
- Photographs:  Aerial (Name & Date): Site Photos contained in Feb 2022 Core Consultants, Inc. Wetland

**Delineation Report**

or  Other (Name & Date): Google Earth- 1999, 2004, 2005, 2006, 2008, 2010, 2011, 2015,

2017, 2019, 2020

- Previous determination(s). File no. and date of response letter:
- Applicable/supporting case law:
- Applicable/supporting scientific literature:
- Other information (please specify):

**B. ADDITIONAL COMMENTS TO SUPPORT JD:**

**HYDROLOGIC / HYDRAULIC CALCULATIONS**



For Colorado Springs and much of the Fountain Creek watershed, the 1-hour depths are fairly uniform and are summarized in Table 6-2. Depending on the location of the project, rainfall depths may be calculated using the described method and the NOAA Atlas maps shown in Figures 6-6 through 6-17.

**Table 6-2. Rainfall Depths for Colorado Springs**

Return Period	1-Hour Depth	6-Hour Depth	24-Hour Depth
2	1.19	1.70	2.10
5	1.50	2.10	2.70
10	1.75	2.40	3.20
25	2.00	2.90	3.60
50	2.25	3.20	4.20
100	2.52	3.50	4.60

Where  $Z = 6,840 \text{ ft}/100$

These depths can be applied to the design storms or converted to intensities (inches/hour) for the Rational Method as described below. However, as the basin area increases, it is unlikely that the reported point rainfalls will occur uniformly over the entire basin. To account for this characteristic of rain storms an adjustment factor, the Depth Area Reduction Factor (DARF) is applied. This adjustment to rainfall depth and its effect on design storms is also described below. The UDFCD UD-Rain spreadsheet, available on UDFCD's website, also provides tools to calculate point rainfall depths and Intensity-Duration-Frequency curves<sup>2</sup> and should produce similar depth calculation results.

## 2.2 Design Storms

Design storms are used as input into rainfall/runoff models and provide a representation of the typical temporal distribution of rainfall events when the creation or routing of runoff hydrographs is required. It has long been observed that rainstorms in the Front Range of Colorado tend to occur as either short-duration, high-intensity, localized, convective thunderstorms (cloud bursts) or longer-duration, lower-intensity, broader, frontal (general) storms. The significance of these two types of events is primarily determined by the size of the drainage basin being studied. Thunderstorms can create high rates of runoff within a relatively small area, quickly, but their influence may not be significant very far downstream. Frontal storms may not create high rates of runoff within smaller drainage basins due to their lower intensity, but tend to produce larger flood flows that can be hazardous over a broader area and extend further downstream.

- **Thunderstorms:** Based on the extensive evaluation of rain storms completed in the Carlton study (Carlton 2011), it was determined that typical thunderstorms have a duration of about 2 hours. The study evaluated over 300,000 storm cells using gage-adjusted NEXRAD data, collected over a 14-year period (1994 to 2008). Storms lasting longer than 3 hours were rarely found. Therefore, the results of the Carlton study have been used to define the shorter duration design storms.

To determine the temporal distribution of thunderstorms, 22 gage-adjusted NEXRAD storm cells were studied in detail. Through a process described in a technical memorandum prepared by the City of Colorado Springs (City of Colorado Springs 2012), the results of this analysis were interpreted and normalized to the 1-hour rainfall depth to create the distribution shown in Table 6-3 with a 5 minute time interval for drainage basins up to 1 square mile in size. This distribution represents the rainfall

**Table 6-6. Runoff Coefficients for Rational Method**  
(Source: UDFCD 2001)

Land Use or Surface Characteristics	Percent Impervious	Runoff Coefficients											
		2-year		5-year		10-year		25-year		50-year		100-year	
		HSG A&B	HSG C&D	HSG A&B	HSG C&D	HSG A&B	HSG C&D	HSG A&B	HSG C&D	HSG A&B	HSG C&D	HSG A&B	HSG C&D
<b>Business</b>													
Commercial Areas	95	0.79	0.80	0.81	0.82	0.83	0.84	0.85	0.87	0.87	0.88	0.88	0.89
Neighborhood Areas	70	0.45	0.49	0.49	0.53	0.53	0.57	0.58	0.62	0.60	0.65	0.62	0.68
<b>Residential</b>													
1/8 Acre or less	65	0.41	0.45	0.45	0.49	0.49	0.54	0.54	0.59	0.57	0.62	0.59	0.65
1/4 Acre	40	0.23	0.28	0.30	0.35	0.36	0.42	0.42	0.50	0.46	0.54	0.50	0.58
1/3 Acre	30	0.18	0.22	0.25	0.30	0.32	0.38	0.39	0.47	0.43	0.52	0.47	0.57
1/2 Acre	25	0.15	0.20	0.22	0.28	0.30	0.36	0.37	0.46	0.41	0.51	0.46	0.56
1 Acre	20	0.12	0.17	0.20	0.26	0.27	0.34	0.35	0.44	0.40	0.50	0.44	0.55
<b>Industrial</b>													
Light Areas	80	0.57	0.60	0.59	0.63	0.63	0.66	0.66	0.70	0.68	0.72	0.70	0.74
Heavy Areas	90	0.71	0.73	0.73	0.75	0.75	0.77	0.78	0.80	0.80	0.82	0.81	0.83
<b>Parks and Cemeteries</b>													
Parks and Cemeteries	7	0.05	0.09	0.12	0.19	0.20	0.29	0.30	0.40	0.34	0.46	0.39	0.52
Playgrounds	13	0.07	0.13	0.16	0.23	0.24	0.31	0.32	0.42	0.37	0.48	0.41	0.54
Railroad Yard Areas	40	0.23	0.28	0.30	0.35	0.36	0.42	0.42	0.50	0.46	0.54	0.50	0.58
<b>Undeveloped Areas</b>													
Historic Flow Analysis-- Greenbelts, Agriculture	2	0.03	0.05	0.09	0.16	0.17	0.26	0.26	0.38	0.31	0.45	0.36	0.51
Pasture/Meadow	0	0.02	0.04	0.08	0.15	0.15	0.25	0.25	0.37	0.30	0.44	0.35	0.50
Forest	0	0.02	0.04	0.08	0.15	0.15	0.25	0.25	0.37	0.30	0.44	0.35	0.50
Exposed Rock	100	0.89	0.89	0.90	0.90	0.92	0.92	0.94	0.94	0.95	0.95	0.96	0.96
Offsite Flow Analysis (when landuse is undefined)	45	0.26	0.31	0.32	0.37	0.38	0.44	0.44	0.51	0.48	0.55	0.51	0.59
<b>Streets</b>													
Paved	100	0.89	0.89	0.90	0.90	0.92	0.92	0.94	0.94	0.95	0.95	0.96	0.96
Gravel	80	0.57	0.60	0.59	0.63	0.63	0.66	0.66	0.70	0.68	0.72	0.70	0.74
<b>Drive and Walks</b>													
Drive and Walks	100	0.89	0.89	0.90	0.90	0.92	0.92	0.94	0.94	0.95	0.95	0.96	0.96
<b>Roofs</b>													
Roofs	90	0.71	0.73	0.73	0.75	0.75	0.77	0.78	0.80	0.80	0.82	0.81	0.83
<b>Lawns</b>													
Lawns	0	0.02	0.04	0.08	0.15	0.15	0.25	0.25	0.37	0.30	0.44	0.35	0.50

### 3.2 Time of Concentration

One of the basic assumptions underlying the Rational Method is that runoff is a function of the average rainfall rate during the time required for water to flow from the hydraulically most remote part of the drainage area under consideration to the design point. However, in practice, the time of concentration can be an empirical value that results in reasonable and acceptable peak flow calculations.

For urban areas, the time of concentration ( $t_c$ ) consists of an initial time or overland flow time ( $t_i$ ) plus the travel time ( $t_t$ ) in the storm sewer, paved gutter, roadside drainage ditch, or drainage channel. For non-urban areas, the time of concentration consists of an overland flow time ( $t_i$ ) plus the time of travel in a concentrated form, such as a swale or drainageway. The travel portion ( $t_t$ ) of the time of concentration can be estimated from the hydraulic properties of the storm sewer, gutter, swale, ditch, or drainageway. Initial time, on the other hand, will vary with surface slope, depression storage, surface cover, antecedent rainfall, and infiltration capacity of the soil, as well as distance of surface flow. The time of concentration is represented by Equation 6-7 for both urban and non-urban areas.

**Table 6-7. Conveyance Coefficient,  $C_v$** 

Type of Land Surface	$C_v$
Heavy meadow	2.5
Tillage/field	5
Riprap (not buried)*	6.5
Short pasture and lawns	7
Nearly bare ground	10
Grassed waterway	15
Paved areas and shallow paved swales	20

\* For buried riprap, select  $C_v$  value based on type of vegetative cover.

The travel time is calculated by dividing the flow distance (in feet) by the velocity calculated using Equation 6-9 and converting units to minutes.

The time of concentration ( $t_c$ ) is then the sum of the overland flow time ( $t_i$ ) and the travel time ( $t_t$ ) per Equation 6-7.

### 3.2.3 First Design Point Time of Concentration in Urban Catchments

Using this procedure, the time of concentration at the first design point (typically the first inlet in the system) in an urbanized catchment should not exceed the time of concentration calculated using Equation 6-10. The first design point is defined as the point where runoff first enters the storm sewer system.

$$t_c = \frac{L}{180} + 10 \quad (\text{Eq. 6-10})$$

Where:

$t_c$  = maximum time of concentration at the first design point in an urban watershed (min)

$L$  = waterway length (ft)

Equation 6-10 was developed using the rainfall-runoff data collected in the Denver region and, in essence, represents regional “calibration” of the Rational Method. Normally, Equation 6-10 will result in a lesser time of concentration at the first design point and will govern in an urbanized watershed. For subsequent design points, the time of concentration is calculated by accumulating the travel times in downstream drainageway reaches.

### 3.2.4 Minimum Time of Concentration

If the calculations result in a  $t_c$  of less than 10 minutes for undeveloped conditions, it is recommended that a minimum value of 10 minutes be used. The minimum  $t_c$  for urbanized areas is 5 minutes.

### 3.2.5 Post-Development Time of Concentration

As Equation 6-8 indicates, the time of concentration is a function of the 5-year runoff coefficient for a drainage basin. Typically, higher levels of imperviousness (higher 5-year runoff coefficients) correspond to shorter times of concentration, and lower levels of imperviousness correspond to longer times of

**Figure 6-5. Colorado Springs Rainfall Intensity Duration Frequency**

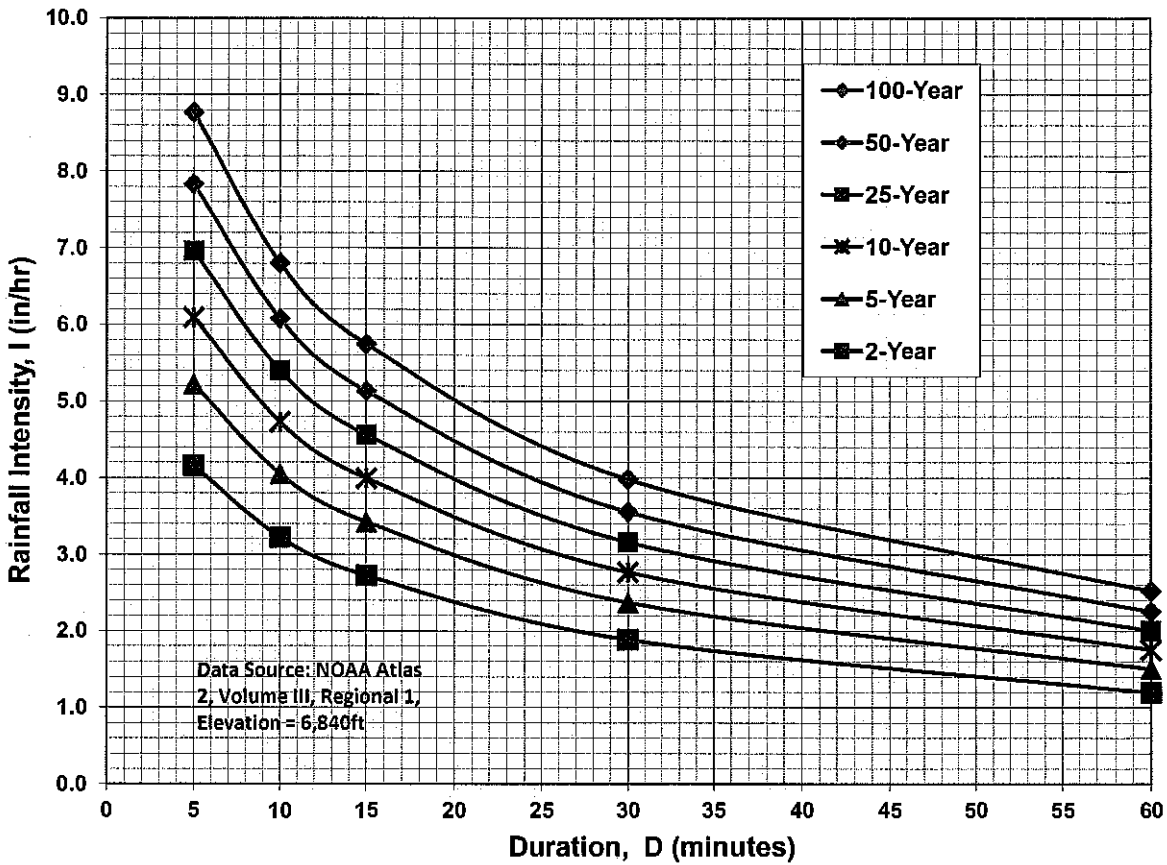

**IDF Equations**

$I_{100} = -2.52 \ln(D) + 12.735$

$I_{50} = -2.25 \ln(D) + 11.375$

$I_{25} = -2.00 \ln(D) + 10.111$

$I_{10} = -1.75 \ln(D) + 8.847$

$I_5 = -1.50 \ln(D) + 7.583$

$I_2 = -1.19 \ln(D) + 6.035$

Note: Values calculated by equations may not precisely duplicate values read from figure.

JOB NAME: MONUMENT JUNCTION DEVELOPMENT (HWY. 105 & JCP INT. IMPS.)  
 JOB NUMBER: 1302.22  
 DATE: 02/24/23  
 CALCULATED BY: MAW

**FINAL DRAINAGE REPORT ~ BASIN RUNOFF COEFFICIENT SUMMARY**

BASIN	TOTAL AREA (AC)	DEVELOPED AREA/IMPERVIOUS AREA				LANDSCAPE/UNDEVELOPED AREAS				WEIGHTED			WEIGHTED CA			IMPERVIOUSNESS
		AREA (AC)	C(2)	C(5)	C(100)	AREA (AC)	C(2)	C(5)	C(100)	C(2)	C(5)	C(100)	CA(2)	CA(5)	CA(100)	%
G	0.20	0.05	0.79	0.81	0.88	0.15	0.03	0.09	0.36	0.22	0.27	0.49	0.04	0.05	0.10	25%
H	0.57	0.05	0.79	0.81	0.88	0.52	0.03	0.09	0.36	0.10	0.15	0.41	0.06	0.09	0.23	10%
OS-10	4.10	0.60	0.89	0.90	0.96	3.50	0.03	0.09	0.36	0.16	0.21	0.45	0.64	0.86	1.84	16%
OS10D	2.00	0.10	0.89	0.90	0.96	1.90	0.03	0.09	0.36	0.07	0.13	0.39	0.15	0.26	0.78	7%
OS-11	1.70	0.80	0.89	0.90	0.96	0.90	0.02	0.08	0.35	0.43	0.47	0.64	0.73	0.79	1.08	45%
OS11D	1.70	1.20	0.89	0.90	0.96	0.50	0.03	0.09	0.36	0.64	0.66	0.78	1.08	1.13	1.33	71%
OS-12	0.51	0.27	0.89	0.90	0.96	0.24	0.03	0.09	0.36	0.49	0.52	0.68	0.25	0.26	0.35	54%
OS12D	0.58	0.31	0.89	0.90	0.96	0.27	0.03	0.09	0.36	0.49	0.52	0.68	0.28	0.30	0.39	54%
OS-13	0.67	0.40	0.89	0.90	0.96	0.27	0.03	0.09	0.36	0.54	0.57	0.72	0.36	0.38	0.48	61%
OS13D	0.67	0.40	0.89	0.90	0.96	0.27	0.03	0.09	0.36	0.54	0.57	0.72	0.36	0.38	0.48	61%
OS-14	0.28	0.15	0.89	0.90	0.96	0.13	0.03	0.09	0.36	0.49	0.52	0.68	0.14	0.15	0.19	55%
OS14D	0.86	0.72	0.89	0.90	0.96	0.14	0.03	0.09	0.36	0.75	0.77	0.86	0.65	0.66	0.74	84%
OS-15	1.60	1.20	0.89	0.90	0.96	0.40	0.03	0.09	0.36	0.68	0.70	0.81	1.08	1.12	1.30	76%
OS15D	1.60	1.20	0.89	0.90	0.96	0.40	0.03	0.09	0.36	0.68	0.70	0.81	1.08	1.12	1.30	76%
OS-16	1.00	0.70	0.89	0.90	0.96	0.30	0.02	0.08	0.35	0.63	0.65	0.78	0.63	0.65	0.78	67%
OS-17	0.53	0.43	0.89	0.90	0.96	0.10	0.03	0.09	0.36	0.73	0.75	0.85	0.39	0.40	0.45	82%
OS17D	1.00	0.60	0.89	0.90	0.96	0.40	0.03	0.09	0.36	0.55	0.58	0.72	0.55	0.58	0.72	61%
OS-18	0.30	0.30	0.89	0.90	0.96	0.00	0.03	0.09	0.36	0.89	0.90	0.96	0.27	0.27	0.29	100%
OS18D	0.78	0.43	0.89	0.90	0.96	0.35	0.03	0.09	0.36	0.50	0.54	0.69	0.39	0.42	0.54	56%
OS-19	0.18	0.00	0.89	0.90	0.96	0.18	0.03	0.09	0.36	0.03	0.09	0.36	0.01	0.02	0.06	2%
OS-20	0.11	0.01	0.89	0.90	0.96	0.10	0.03	0.09	0.36	0.11	0.16	0.41	0.01	0.02	0.05	10%
JCP7	0.59	0.50	0.89	0.90	0.96	0.09	0.03	0.09	0.36	0.76	0.78	0.87	0.45	0.46	0.51	85%
EX2	0.56	0.56	0.03	0.09	0.36	0.00	0.03	0.09	0.36	0.03	0.09	0.36	0.02	0.05	0.20	2%
EX3	1.80	1.80	0.03	0.09	0.36	0.00	0.03	0.09	0.36	0.03	0.09	0.36	0.05	0.16	0.65	2%
Exist. Trib. to Pond	13.05															37.5%
Dev. Trib. to Pond	11.84															53.6%
Dev. Trib. to Forebay	8.49															67.2%

JOB NAME: MONUMENT JUNCTION DEVELOPMENT (HWY. 105 & JCP INT. IMPS.)  
 JOB NUMBER: 1302.22  
 DATE: 02/24/23  
 CALC'D BY: MAW

Table 6-7. Conveyance Coefficient,  $C_v$

Type of Land Surface	$C_v$
Heavy meadow	2.5
Tillage/field	5
Riprap (not buried)* $t_c = \frac{L}{180} + 10$	6.5
Short pasture and lawns	7
Nearly bare ground	10
Grassed waterway	15
Paved areas and shallow paved swales	20

\*For buried riprap, select  $C_v$  value based on type of vegetative cover.

Return Period	1-Hour Depth
2	1.19
5	1.50
10	1.75
25	2.00
50	2.25
100	2.52

$$t_i = \frac{0.395(1.1 - C_s)\sqrt{L}}{S^{0.33}}$$

$$V = C_v S_w^{0.5} \quad T_c = L/V$$

### FINAL DRAINAGE REPORT ~ BASIN RUNOFF SUMMARY

BASIN	WEIGHTED			OVERLAND			STREET / CHANNEL FLOW				Tc TOTAL (min)	INTENSITY			TOTAL FLOWS			
	CA(2)	CA(5)	CA(100)	C(5)	Length (ft)	Height (ft)	Tc (min)	Length (ft)	Slope (%)	Velocity (fps)		Tc (min)	I(2) (in/hr)	I(5) (in/hr)	I(100) (in/hr)	Q(2) (cfs)	Q(5) (cfs)	Q(100) (cfs)
G	0.04	0.05	0.10	0.09	30	1.5	5.9					5.9	3.93	4.93	8.27	0.17	0.3	0.8
H	0.06	0.09	0.23	0.09	40	2	6.8					6.8	3.76	4.71	7.91	0.2	0.4	1.8
OS-10	0.64	0.86	1.84	0.09	65	2	10.1	950	3.5%	1.9	8.5	18.6	2.56	3.20	5.37	2	3	10
OS10D	0.15	0.26	0.78	0.09	65	2	10.1	950	3.5%	1.9	8.5	18.6	2.56	3.20	5.37	0.4	0.8	4
OS-11	0.73	0.79	1.08	0.08	100	2	14.7	500	4.0%	2.0	4.2	18.8	2.54	3.18	5.34	1.9	3	6
OS11D	1.08	1.13	1.33	0.09	100	2	14.5	300	4.0%	2.0	2.5	17.0	2.66	3.33	5.59	3	4	7
OS-12	0.25	0.26	0.35	0.09	40	2	6.8	200	3.5%	3.7	0.9	7.7	3.61	4.53	7.60	0.9	1.2	3
OS12D	0.28	0.30	0.39	0.09	40	2	6.8	200	3.5%	3.7	0.9	7.7	3.61	4.53	7.60	1.0	1.4	3.0
OS-13	0.36	0.38	0.48	0.09	25	3	4.0	240	5.5%	4.7	0.9	5.0	4.12	5.17	8.68	1.5	2	4
OS13D	0.36	0.38	0.48	0.09	25	3	4.0	250	3.5%	3.7	1.1	5.1	4.09	5.13	8.61	1.5	2	4
OS-14	0.14	0.15	0.19	0.09	30	10	3.1	170	5.5%	4.7	0.6	5.0	4.12	5.17	8.68	0.6	0.8	2
OS14D	0.65	0.66	0.74	0.09	30	10	3.1	190	5.5%	4.7	0.7	5.0	4.12	5.17	8.68	3	3	6
OS-15	1.08	1.12	1.30	0.09	180	12	13.1	100	3.0%	1.7	1.0	14.0	2.89	3.62	6.08	3	4	8
OS15D	1.08	1.12	1.30	0.09	180	12	13.1	80	3.0%	3.5	0.4	13.5	2.94	3.68	6.18	3	4	8
OS-16	0.63	0.65	0.78	0.08	100	4	11.7	130	1.5%	1.2	1.8	13.4	2.94	3.69	6.19	1.9	2	5



JOB NAME: MONUMENT JUNCTION DEVELOPMENT (HWY. 105 & JCP INT. IMPS.)  
 JOB NUMBER: 1302.22  
 DATE: 02/24/23  
 CALC'D BY: MAW

Table 6-7. Conveyance Coefficient,  $C_v$

Type of Land Surface	$C_v$
Heavy meadow	2.5
Tillage/field	5
Riprap (not buried)* $t_c = \frac{L}{180} + 10$	6.5
Short pasture and lawns	7
Nearly bare ground	10
Grassed waterway	15
Paved areas and shallow paved swales	20

\*For buried riprap, select  $C_v$  value based on type of vegetative cover.

Return Period	1-Hour Depth
2	1.19
5	1.50
10	1.75
25	2.00
50	2.25
100	2.52

$$t_i = \frac{0.395(1.1 - C_s)\sqrt{L}}{S^{0.33}}$$

$$V = C_v S_w^{0.5} \quad Tc = LV$$

### FINAL DRAINAGE REPORT ~ BASIN RUNOFF SUMMARY

BASIN	WEIGHTED			OVERLAND			STREET / CHANNEL FLOW				Tc TOTAL (min)	INTENSITY			TOTAL FLOWS			
	CA(2)	CA(5)	CA(100)	C(5)	Length (ft)	Height (ft)	Tc (min)	Length (ft)	Slope (%)	Velocity (fps)		Tc (min)	I(2) (in/hr)	I(5) (in/hr)	I(100) (in/hr)	Q(2) (cfs)	Q(5) (cfs)	Q(100) (cfs)
OS-17	0.39	0.40	0.45	0.09	60	14	5.0	380	5.0%	4.5	1.4	6.4	3.82	4.80	8.05	1.5	2	4
OS17D	0.55	0.58	0.72	0.09	60	14	5.0	380	5.0%	4.5	1.4	6.4	3.82	4.80	8.05	2	3	6
OS-18	0.27	0.27	0.29	0.09	15	0.5	4.7	280	2.0%	2.8	1.6	6.4	3.83	4.80	8.06	1.0	1.3	2
OS18D	0.39	0.42	0.54	0.09	90	4	10.6	260	2.0%	2.8	1.5	12.1	3.07	3.84	6.45	1.2	1.6	3
OS-19	0.01	0.02	0.06	0.09	80	3.2	10.3	380	5.0%	4.5	1.4	11.7	3.10	3.89	6.53	0.02	0.1	0.4
OS-20	0.01	0.02	0.05	0.09	50	3	7.1					7.1	3.70	4.63	7.78	0.0	0.1	0.4
JCP7	0.45	0.46	0.51	0.09	20	0.6	5.7	300	4.5%	4.2	1.2	6.9	3.74	4.70	7.88	2	2	4
EX2	0.02	0.05	0.20	0.09	50	2	8.2					8.2	3.54	4.43	7.44	0.1	0.2	1.5
EX3	0.05	0.16	0.65	0.09	260	5	23.7					23.7	2.27	2.84	4.76	0.1	0.5	3

JOB NAME: MONUMENT JUNCTION DEVELOPMENT (HWY. 105 & JCP INT. IMPS.)  
 JOB NUMBER: 1302.22  
 DATE: 07/20/23  
 CALCULATED BY: MAW

**FINAL DRAINAGE REPORT ~ SURFACE ROUTING SUMMARY**

Design Point(s)	Contributing Basins	Equivalent CA(5)	Equivalent CA(100)	Maximum Tc	Intensity		Flow		Inlet Size
					I(5)	I(100)	Q(5)	Q(100)	
H1	OS-1 thru OS-8	6.48	15.46	33.4	2.32	3.89	15	60	EXIST. 60" RCP CULVERT
H2	DP H1, OS-9, EX-1	9.17	25.43	39.4	2.07	3.48	19	88	EXIST. CDOT OUTFALL
H3	EX4	1.49	5.98	35.7	2.22	3.73	3	22	EXIST. SIDE ROAD DITCH
H4	OS-12	0.26	0.46	7.7	4.53	7.60	1	3	EXIST. 5' TYPE R AT-GRADE INLET
H5	OS-13, Flow-by from H4	0.38	0.63	5.0	5.17	8.68	2	5	EXIST. 10' TYPE R AT-GRADE INLET
H6	OS-14, Flow-by from H5	0.15	0.24	5.0	5.17	8.68	1	2	EXIST. 10' TYPE R AT-GRADE INLET
H7	OS-11 and OS-16	1.45	1.86	18.8	3.18	5.34	5	10	EXIST. 10' TYPE R AT-GRADE INLET
H8	OS-17, Flow-by from H7	0.42	0.73	6.4	4.80	8.05	2	6	EXIST. 10' TYPE R AT-GRADE INLET
H9	OS-18, Flow-by from H8	0.27	0.41	6.4	4.80	8.06	1	3	EXIST. 10' TYPE R AT-GRADE INLET
<b>H10</b>	<b>EX2, EX3, OS-10 thru OS-18</b>	<b>5.09</b>	<b>7.60</b>	<b>23.7</b>	<b>2.84</b>	<b>4.76</b>	<b>14</b>	<b>36</b>	<b>EXIST. 36" RCP CDOT CULVERT</b>

JOB NAME: MONUMENT JUNCTION DEVELOPMENT (HWY. 105 & JCP INT. IMPS.)  
 JOB NUMBER: 1302.22  
 DATE: 07/20/23  
 CALCULATED BY: MAW

**FINAL DRAINAGE REPORT ~ SURFACE ROUTING SUMMARY**

Design Point(s)	Contributing Basins	Equivalent CA(5)	Equivalent CA(100)	Maximum Tc	Intensity		Flow		Inlet Size
					I(5)	I(100)	Q(5)	Q(100)	
D4	OS12D, 0.85 CFS 100Yr Flow-by from upstream	0.30	0.51	7.7	4.53	7.60	1.4	3.9	PROP. 5' TYPE R AT-GRADE INLET
D5	OS13D, Flow-by from D4	0.38	0.63	5.0	5.17	8.68	2	5	PROP. 10' TYPE R AT-GRADE INLET
D6	OS15D	1.12	1.30	13.5	3.68	6.18	4	8	PROP. CDOT TYPE C INLET
D7	OS11D, OS-16, OS-19, OS-20	1.81	2.22	17.0	3.33	5.59	6	12	PROP. 10' TYPE R AT-GRADE INLET
D8	OS14D, Flow-by from D5&D7	0.84	1.47	17.0	3.33	5.59	3	8	PROP. 10' TYPE R SUMP INLET
D9	JCP7, G	0.51	0.61	6.9	4.70	7.88	2	5	PROP. 10' TYPE R AT-GRADE INLET
D10	OS17D, Flow-by from D9	0.58	0.74	6.4	4.80	8.05	3	6	PROP. 10' TYPE R AT-GRADE INLET
D11	OS18D, Flow-by from D10	0.42	0.64	12.1	3.84	6.45	2	4	EXIST. 10' TYPE R SUMP INLET
13	G, H, JCP7, OS10D thru OS15D, OS-16, OS17D, OS18D, OS-19, OS-20	5.87	8.01	21.1	3.01	5.05	18	40	SWQ FACILITY in CDOT ROW

JOB NAME: MONUMENT JUNCTION DEVELOPMENT (HWY. 105 & JCP INT. IMPS.)  
 JOB NUMBER: 1302.22  
 DATE: 07/20/23  
 CALCULATED BY: MAW

\* PIPES ARE LISTED AT MAXIMUM SIZE REQUIRED TO ACCOMMODATE Q100 FLOWS AT MINIMUM GRADE.  
 REFER TO INDIVIDUAL PIPE SHEETS FOR HYDRAULIC INFORMATION.

### FINAL DRAINAGE REPORT ~ PIPE ROUTING SUMMARY

Pipe Run	Contributing Basins	Equivalent CA(5)	Equivalent CA(100)	Maximum Tc	Intensity		Flow		Pipe Size*
					I(5)	I(100)	Q(5)	Q(100)	
H1	Inlet Capture at DP-H4	0.26	0.24	7.7	4.53	7.60	1	2	Exist. 15" RCP
H2	PR-H1, Inlet Capture at DP-H5	0.65	0.77	7.8	4.51	7.57	3	6	Exist. 15" RCP
H3	PR-H2, Inlet Capture at DP-H6	0.80	1.01	7.9	4.49	7.54	4	8	Exist. 24" RCP
H4	OS-15	1.12	1.30	14.0	3.62	6.08	4	8	Exist. 18" ADS
H5	PR-H3, PR-H4, Portion of OS-11 and OS-16	3.20	3.95	18.8	3.18	5.34	10	21	Exist. 30" RCP
H6	Inlet Capture at DP-H8	0.42	0.64	6.4	4.80	8.05	2	5	Exist. 24" RCP
H7	Inlet Capture at DP-H9	0.27	0.41	6.4	4.80	8.06	1	3	Exist. 24" RCP

JOB NAME: MONUMENT JUNCTION DEVELOPMENT (HWY. 105 & JCP INT. IMPS.)  
 JOB NUMBER: 1302.22  
 DATE: 07/20/23  
 CALCULATED BY: MAW

\* PIPES ARE LISTED AT MAXIMUM SIZE REQUIRED TO ACCOMMODATE Q100 FLOWS AT MINIMUM GRADE.  
 REFER TO INDIVIDUAL PIPE SHEETS FOR HYDRAULIC INFORMATION.

### FINAL DRAINAGE REPORT ~ PIPE ROUTING SUMMARY

Pipe Run	Contributing Basins	Equivalent CA(5)	Equivalent CA(100)	Maximum Tc	Intensity		Flow		Pipe Size*
					I(5)	I(100)	Q(5)	Q(100)	
1	Inlet Capture at D4	0.30	0.33	7.7	4.53	7.60	1.4	2.5	PROP. 18" RCP
2	PR-1, Inlet Capture at D5	0.69	0.92	7.7	4.53	7.60	3	7	PROP. 24" RCP
3	CDOT Type C Inlet Capture at D6	1.12	1.30	13.5	3.68	6.18	4	8	PROP. 18" RCP
4	PR-2, PR-3	1.80	2.22	13.7	3.66	6.15	7	14	PROP. 24" RCP
5	Inlet Capture at D7	1.63	1.51	17.0	3.33	5.59	5	8	PROP. 18" RCP
6	PR-5, Inlet Capture at D8	2.47	2.98	17.0	3.33	5.59	8	17	PROP. 24" RCP
7	PR-6, Inlet Capture at D9	2.98	3.56	17.0	3.33	5.59	10	20	PROP. 24" RCP
8	PR-4, PR-7	4.79	5.77	17.2	3.32	5.56	16	32	PROP. 30" RCP
9	Inlet Capture at D10	0.58	0.66	6.4	4.80	8.05	3	5	PROP. 18" RCP
10	PR-8, PR9	5.36	6.43	17.4	3.30	5.54	18	36	PROP. 30" RCP
11	Inlet Capture at D11	0.42	0.64	12.1	3.84	6.45	2	4	EXIST. 18" RCP

**ALLOWABLE CAPACITY FOR ONE-HALF OF STREET (Minor & Major Storm)**

(Based on Regulated Criteria for Maximum Allowable Flow Depth and Spread)

Project: **MONUMENT JUNCTION - HWY. 105/JCP INT. IMPS.**  
 Inlet ID: **H4**

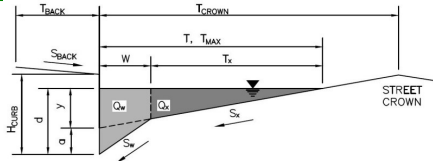

Gutter Geometry (Enter data in the blue cells)							
Maximum Allowable Width for Spread Behind Curb	$T_{BACK} = 7.0$ ft						
Side Slope Behind Curb (leave blank for no conveyance credit behind curb)	$S_{BACK} = 0.020$ ft/ft						
Manning's Roughness Behind Curb (typically between 0.012 and 0.020)	$n_{BACK} = 0.016$						
Height of Curb at Gutter Flow Line	$H_{CURB} = 6.00$ inches						
Distance from Curb Face to Street Crown	$T_{CROWN} = 35.0$ ft						
Gutter Width	$W = 2.00$ ft						
Street Transverse Slope	$S_x = 0.020$ ft/ft						
Gutter Cross Slope (typically 2 inches over 24 inches or 0.083 ft/ft)	$S_W = 0.083$ ft/ft						
Street Longitudinal Slope - Enter 0 for sump condition	$S_D = 0.035$ ft/ft						
Manning's Roughness for Street Section (typically between 0.012 and 0.020)	$n_{STREET} = 0.016$						
Max. Allowable Spread for Minor & Major Storm	<table border="1"> <tr> <th>Minor Storm</th> <th>Major Storm</th> <th>ft</th> </tr> <tr> <td><math>T_{MAX} = 14.0</math></td> <td><math>T_{MAX} = 25.0</math></td> <td></td> </tr> </table>	Minor Storm	Major Storm	ft	$T_{MAX} = 14.0$	$T_{MAX} = 25.0$	
Minor Storm	Major Storm	ft					
$T_{MAX} = 14.0$	$T_{MAX} = 25.0$						
Max. Allowable Depth at Gutter Flowline for Minor & Major Storm	<table border="1"> <tr> <th>Minor Storm</th> <th>Major Storm</th> <th>inches</th> </tr> <tr> <td><math>d_{MAX} = 3.4</math></td> <td><math>d_{MAX} = 6.0</math></td> <td></td> </tr> </table>	Minor Storm	Major Storm	inches	$d_{MAX} = 3.4$	$d_{MAX} = 6.0$	
Minor Storm	Major Storm	inches					
$d_{MAX} = 3.4$	$d_{MAX} = 6.0$						
Allow Flow Depth at Street Crown (leave blank for no)	<input type="checkbox"/> <input type="checkbox"/> check = yes						
<b>MINOR STORM Allowable Capacity is based on Depth Criterion</b>							
<b>MAJOR STORM Allowable Capacity is based on Depth Criterion</b>							
<b>Minor storm max. allowable capacity GOOD - greater than the design flow given on sheet 'Inlet Management'</b>							
<b>Major storm max. allowable capacity GOOD - greater than the design flow given on sheet 'Inlet Management'</b>							
	<table border="1"> <tr> <th>Minor Storm</th> <th>Major Storm</th> <th>cfs</th> </tr> <tr> <td><math>Q_{allow} = 3.6</math></td> <td><math>Q_{allow} = 13.7</math></td> <td></td> </tr> </table>	Minor Storm	Major Storm	cfs	$Q_{allow} = 3.6$	$Q_{allow} = 13.7$	
Minor Storm	Major Storm	cfs					
$Q_{allow} = 3.6$	$Q_{allow} = 13.7$						

**NOW INCLUDED**

Unresolved:  
 Include calculation for drainage swale along top of retaining wall to show that it is sized to handle the flow.

## INLET ON A CONTINUOUS GRADE

Version 4.06 Released August 2018

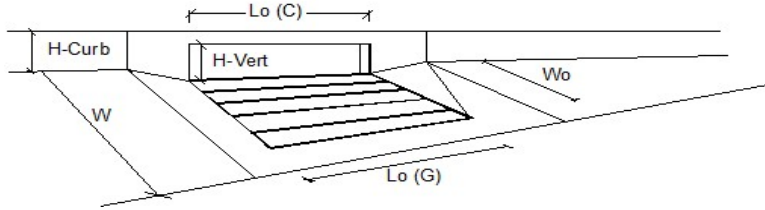

Design Information (Input)	MINOR	MAJOR	
Type of Inlet	CDOT Type R Curb Opening		
Local Depression (additional to continuous gutter depression 'a')	3.0	3.0	inches
Total Number of Units in the Inlet (Grate or Curb Opening)	1	1	
Length of a Single Unit Inlet (Grate or Curb Opening)	5.00	5.00	ft
Width of a Unit Grate (cannot be greater than W, Gutter Width)	N/A	N/A	ft
Clogging Factor for a Single Unit Grate (typical min. value = 0.5)	N/A	N/A	
Clogging Factor for a Single Unit Curb Opening (typical min. value = 0.1)	0.10	0.10	
<b>Street Hydraulics: OK - Q &lt; Allowable Street Capacity*</b>			
Total Inlet Interception Capacity	1.0	2.5	cfs
Total Inlet Carry-Over Flow (flow bypassing inlet)	0.0	1.3	cfs
Capture Percentage = $Q_p/Q_o =$	100	66	%

**ALLOWABLE CAPACITY FOR ONE-HALF OF STREET (Minor & Major Storm)**

(Based on Regulated Criteria for Maximum Allowable Flow Depth and Spread)

Project: **MONUMENT JUNCTION - HWY. 105/JCP INT. IMPS.**  
 Inlet ID: **H5**

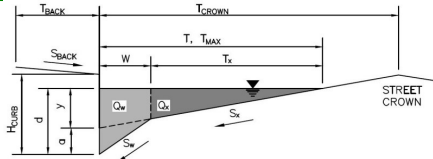

**Gutter Geometry (Enter data in the blue cells)**

Maximum Allowable Width for Spread Behind Curb  
 Side Slope Behind Curb (leave blank for no conveyance credit behind curb)  
 Manning's Roughness Behind Curb (typically between 0.012 and 0.020)

$T_{BACK} = 4.0$  ft  
 $S_{BACK} = 0.250$  ft/ft  
 $n_{BACK} = 0.020$

Height of Curb at Gutter Flow Line  
 Distance from Curb Face to Street Crown  
 Gutter Width  
 Street Transverse Slope  
 Gutter Cross Slope (typically 2 inches over 24 inches or 0.083 ft/ft)  
 Street Longitudinal Slope - Enter 0 for sump condition  
 Manning's Roughness for Street Section (typically between 0.012 and 0.020)

$H_{CURB} = 6.00$  inches  
 $T_{CROWN} = 30.0$  ft  
 $W = 2.00$  ft  
 $S_x = 0.020$  ft/ft  
 $S_w = 0.083$  ft/ft  
 $S_o = 0.056$  ft/ft  
 $n_{STREET} = 0.016$

Max. Allowable Spread for Minor & Major Storm  
 Max. Allowable Depth at Gutter Flowline for Minor & Major Storm  
 Allow Flow Depth at Street Crown (leave blank for no)

	Minor Storm	Major Storm	
$T_{MAX} =$	14.0	25.0	ft
$d_{MAX} =$	3.4	6.0	inches
	<input type="checkbox"/>	<input type="checkbox"/>	check = yes

**MINOR STORM Allowable Capacity is based on Depth Criterion**  
**MAJOR STORM Allowable Capacity is based on Depth Criterion**

	Minor Storm	Major Storm	
$Q_{allow} =$	4.5	11.9	cfs

**Minor storm max. allowable capacity GOOD - greater than the design flow given on sheet 'Inlet Management'**  
**Major storm max. allowable capacity GOOD - greater than the design flow given on sheet 'Inlet Management'**



## INLET ON A CONTINUOUS GRADE

Version 4.06 Released August 2018

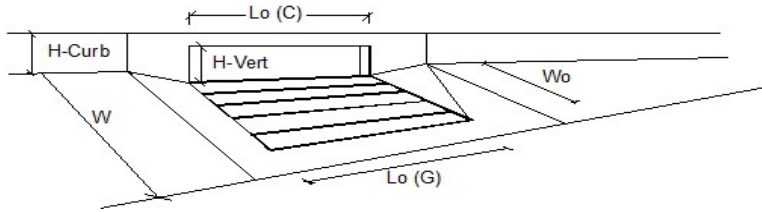

Design Information (Input)	MINOR	MAJOR	
Type of Inlet	CDOT Type R Curb Opening		
Local Depression (additional to continuous gutter depression 'a')	3.0	3.0	inches
Total Number of Units in the Inlet (Grate or Curb Opening)	1	1	
Length of a Single Unit Inlet (Grate or Curb Opening)	10.00	10.00	ft
Width of a Unit Grate (cannot be greater than W, Gutter Width)	N/A	N/A	ft
Clogging Factor for a Single Unit Grate (typical min. value = 0.5)	N/A	N/A	
Clogging Factor for a Single Unit Curb Opening (typical min. value = 0.1)	0.10	0.10	
<b>Street Hydraulics: OK - Q &lt; Allowable Street Capacity*</b>			
Total Inlet Interception Capacity	2.0	4.9	cfs
Total Inlet Carry-Over Flow (flow bypassing inlet)	0.0	0.4	cfs
Capture Percentage = $Q_p/Q_o$ =	100	93	%

**ALLOWABLE CAPACITY FOR ONE-HALF OF STREET (Minor & Major Storm)**

(Based on Regulated Criteria for Maximum Allowable Flow Depth and Spread)

Project: **MONUMENT JUNCTION - HWY. 105/JCP INT. IMPS.**  
 Inlet ID: **H6**

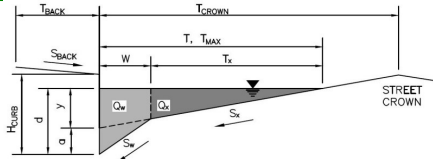

**Gutter Geometry (Enter data in the blue cells)**

Maximum Allowable Width for Spread Behind Curb  
 Side Slope Behind Curb (leave blank for no conveyance credit behind curb)  
 Manning's Roughness Behind Curb (typically between 0.012 and 0.020)

$T_{BACK} = 4.0$  ft  
 $S_{BACK} = 0.250$  ft/ft  
 $n_{BACK} = 0.020$

Height of Curb at Gutter Flow Line  
 Distance from Curb Face to Street Crown  
 Gutter Width  
 Street Transverse Slope  
 Gutter Cross Slope (typically 2 inches over 24 inches or 0.083 ft/ft)  
 Street Longitudinal Slope - Enter 0 for sump condition  
 Manning's Roughness for Street Section (typically between 0.012 and 0.020)

$H_{CURB} = 6.00$  inches  
 $T_{CROWN} = 28.0$  ft  
 $W = 2.00$  ft  
 $S_x = 0.020$  ft/ft  
 $S_w = 0.083$  ft/ft  
 $S_o = 0.057$  ft/ft  
 $n_{STREET} = 0.016$

Max. Allowable Spread for Minor & Major Storm  
 Max. Allowable Depth at Gutter Flowline for Minor & Major Storm  
 Allow Flow Depth at Street Crown (leave blank for no)

	Minor Storm	Major Storm	
$T_{MAX} =$	14.0	25.0	ft
$d_{MAX} =$	3.4	6.0	inches
	<input type="checkbox"/>	<input type="checkbox"/>	check = yes

**MINOR STORM Allowable Capacity is based on Depth Criterion**  
**MAJOR STORM Allowable Capacity is based on Depth Criterion**

	Minor Storm	Major Storm	
$Q_{allow} =$	4.5	11.9	cfs

**Minor storm max. allowable capacity GOOD - greater than the design flow given on sheet 'Inlet Management'**  
**Major storm max. allowable capacity GOOD - greater than the design flow given on sheet 'Inlet Management'**

## INLET ON A CONTINUOUS GRADE

Version 4.06 Released August 2018

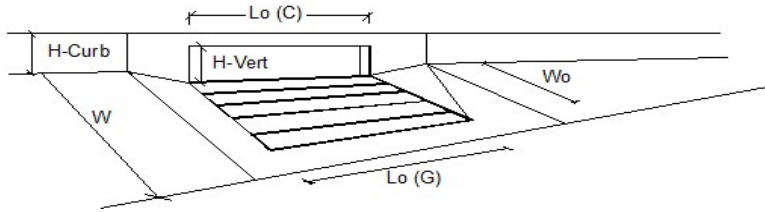

Design Information (Input)	MINOR	MAJOR	
Type of Inlet	CDOT Type R Curb Opening		
Local Depression (additional to continuous gutter depression 'a')	3.0	3.0	inches
Total Number of Units in the Inlet (Grate or Curb Opening)	1	1	
Length of a Single Unit Inlet (Grate or Curb Opening)	10.00	10.00	ft
Width of a Unit Grate (cannot be greater than W, Gutter Width)	N/A	N/A	ft
Clogging Factor for a Single Unit Grate (typical min. value = 0.5)	N/A	N/A	
Clogging Factor for a Single Unit Curb Opening (typical min. value = 0.1)	0.10	0.10	
<b>Street Hydraulics: OK - Q &lt; Allowable Street Capacity*</b>			
Total Inlet Interception Capacity	1.0	2.4	cfs
Total Inlet Carry-Over Flow (flow bypassing inlet)	0.0	0.0	cfs
Capture Percentage = $Q_p/Q_o$ =	100	100	%

**ALLOWABLE CAPACITY FOR ONE-HALF OF STREET (Minor & Major Storm)**

(Based on Regulated Criteria for Maximum Allowable Flow Depth and Spread)

MONUMENT JUNCTION - HWY. 105/JCP INT. IMPS.

Project:  
Inlet ID:

H7

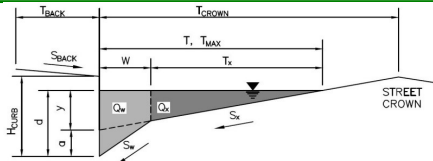

**Gutter Geometry (Enter data in the blue cells)**

Maximum Allowable Width for Spread Behind Curb  
Side Slope Behind Curb (leave blank for no conveyance credit behind curb)  
Manning's Roughness Behind Curb (typically between 0.012 and 0.020)

$T_{BACK} = 8.0$  ft  
 $S_{BACK} = 0.020$  ft/ft  
 $n_{BACK} = 0.020$

Height of Curb at Gutter Flow Line  
Distance from Curb Face to Street Crown  
Gutter Width  
Street Transverse Slope  
Gutter Cross Slope (typically 2 inches over 24 inches or 0.083 ft/ft)  
Street Longitudinal Slope - Enter 0 for sump condition  
Manning's Roughness for Street Section (typically between 0.012 and 0.020)

$H_{CURB} = 6.00$  inches  
 $T_{CROWN} = 14.0$  ft  
 $W = 2.00$  ft  
 $S_x = 0.040$  ft/ft  
 $S_w = 0.083$  ft/ft  
 $S_o = 0.020$  ft/ft  
 $n_{STREET} = 0.016$

Max. Allowable Spread for Minor & Major Storm  
Max. Allowable Depth at Gutter Flowline for Minor & Major Storm  
Allow Flow Depth at Street Crown (leave blank for no)

	Minor Storm	Major Storm	
$T_{MAX} =$	14.0	14.0	ft
$d_{MAX} =$	5.0	6.0	inches
	<input type="checkbox"/>	<input type="checkbox"/>	check = yes

**MINOR STORM Allowable Capacity is based on Depth Criterion**  
**MAJOR STORM Allowable Capacity is based on Depth Criterion**

	Minor Storm	Major Storm	
$Q_{allow} =$	7.4	10.7	cfs

**Minor storm max. allowable capacity GOOD - greater than the design flow given on sheet 'Inlet Management'**  
**Major storm max. allowable capacity GOOD - greater than the design flow given on sheet 'Inlet Management'**

## INLET ON A CONTINUOUS GRADE

Version 4.06 Released August 2018

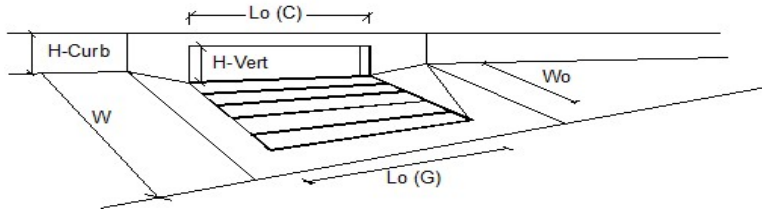

Design Information (Input)	MINOR	MAJOR	
Type of Inlet	CDOT Type R Curb Opening		
Local Depression (additional to continuous gutter depression 'a')	3.0	3.0	inches
Total Number of Units in the Inlet (Grate or Curb Opening)	1	1	
Length of a Single Unit Inlet (Grate or Curb Opening)	10.00	10.00	ft
Width of a Unit Grate (cannot be greater than W, Gutter Width)	N/A	N/A	ft
Clogging Factor for a Single Unit Grate (typical min. value = 0.5)	N/A	N/A	
Clogging Factor for a Single Unit Curb Opening (typical min. value = 0.1)	0.10	0.10	
<b>Street Hydraulics: OK - Q &lt; Allowable Street Capacity*</b>			
Total Inlet Interception Capacity	4.9	7.7	cfs
Total Inlet Carry-Over Flow (flow bypassing inlet)	0.1	2.3	cfs
Capture Percentage = $Q_p/Q_o$ =	97	77	%

**ALLOWABLE CAPACITY FOR ONE-HALF OF STREET (Minor & Major Storm)**

(Based on Regulated Criteria for Maximum Allowable Flow Depth and Spread)

MONUMENT JUNCTION - HWY. 105/JCP INT. IMPS.

Project:  
Inlet ID:

H8

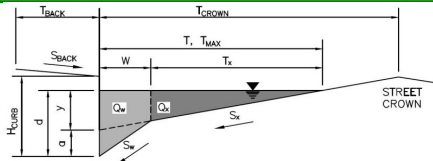

**Gutter Geometry (Enter data in the blue cells)**

Maximum Allowable Width for Spread Behind Curb  
Side Slope Behind Curb (leave blank for no conveyance credit behind curb)  
Manning's Roughness Behind Curb (typically between 0.012 and 0.020)

$T_{BACK} = 6.0$  ft  
 $S_{BACK} = 0.020$  ft/ft  
 $n_{BACK} = 0.020$

Height of Curb at Gutter Flow Line  
Distance from Curb Face to Street Crown  
Gutter Width  
Street Transverse Slope  
Gutter Cross Slope (typically 2 inches over 24 inches or 0.083 ft/ft)  
Street Longitudinal Slope - Enter 0 for sump condition  
Manning's Roughness for Street Section (typically between 0.012 and 0.020)

$H_{CURB} = 6.00$  inches  
 $T_{CROWN} = 30.0$  ft  
 $W = 2.00$  ft  
 $S_x = 0.020$  ft/ft  
 $S_w = 0.083$  ft/ft  
 $S_o = 0.022$  ft/ft  
 $n_{STREET} = 0.016$

Max. Allowable Spread for Minor & Major Storm  
Max. Allowable Depth at Gutter Flowline for Minor & Major Storm  
Allow Flow Depth at Street Crown (leave blank for no)

	Minor Storm	Major Storm	
$T_{MAX} =$	14.0	25.0	ft
$d_{MAX} =$	3.4	6.0	inches
	<input type="checkbox"/>	<input type="checkbox"/>	check = yes

**MINOR STORM Allowable Capacity is based on Depth Criterion**  
**MAJOR STORM Allowable Capacity is based on Depth Criterion**

	Minor Storm	Major Storm	
$Q_{allow} =$	2.8	15.8	cfs

**Minor storm max. allowable capacity GOOD - greater than the design flow given on sheet 'Inlet Management'**  
**Major storm max. allowable capacity GOOD - greater than the design flow given on sheet 'Inlet Management'**

## INLET ON A CONTINUOUS GRADE

Version 4.06 Released August 2018

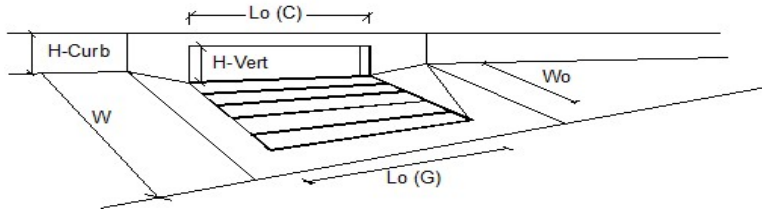

Design Information (Input)	MINOR	MAJOR	
Type of Inlet	CDOT Type R Curb Opening		
Local Depression (additional to continuous gutter depression 'a')	3.0	3.0	inches
Total Number of Units in the Inlet (Grate or Curb Opening)	1	1	
Length of a Single Unit Inlet (Grate or Curb Opening)	10.00	10.00	ft
Width of a Unit Grate (cannot be greater than W, Gutter Width)	N/A	N/A	ft
Clogging Factor for a Single Unit Grate (typical min. value = 0.5)	N/A	N/A	
Clogging Factor for a Single Unit Curb Opening (typical min. value = 0.1)	0.10	0.10	
<b>Street Hydraulics: OK - Q &lt; Allowable Street Capacity*</b>			
Total Inlet Interception Capacity	2.1	5.5	cfs
Total Inlet Carry-Over Flow (flow bypassing inlet)	0.0	0.8	cfs
Capture Percentage = $Q_p/Q_o$ =	100	87	%

**ALLOWABLE CAPACITY FOR ONE-HALF OF STREET (Minor & Major Storm)**

(Based on Regulated Criteria for Maximum Allowable Flow Depth and Spread)

MONUMENT JUNCTION - HWY. 105/JCP INT. IMPS.

Project:  
Inlet ID:

H9

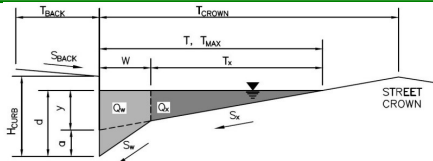

**Gutter Geometry (Enter data in the blue cells)**

Maximum Allowable Width for Spread Behind Curb  
Side Slope Behind Curb (leave blank for no conveyance credit behind curb)  
Manning's Roughness Behind Curb (typically between 0.012 and 0.020)

$T_{BACK} = 6.0$  ft  
 $S_{BACK} = 0.020$  ft/ft  
 $n_{BACK} = 0.020$

Height of Curb at Gutter Flow Line  
Distance from Curb Face to Street Crown  
Gutter Width  
Street Transverse Slope  
Gutter Cross Slope (typically 2 inches over 24 inches or 0.083 ft/ft)  
Street Longitudinal Slope - Enter 0 for sump condition  
Manning's Roughness for Street Section (typically between 0.012 and 0.020)

$H_{CURB} = 6.00$  inches  
 $T_{CROWN} = 38.0$  ft  
 $W = 2.00$  ft  
 $S_x = 0.020$  ft/ft  
 $S_w = 0.083$  ft/ft  
 $S_D = 0.000$  ft/ft  
 $n_{STREET} = 0.016$

Max. Allowable Spread for Minor & Major Storm  
Max. Allowable Depth at Gutter Flowline for Minor & Major Storm  
Check boxes are not applicable in SUMP conditions

	Minor Storm	Major Storm	
$T_{MAX} =$	16.0	25.0	ft
$d_{MAX} =$	3.8	6.0	inches
	<input type="checkbox"/>	<input type="checkbox"/>	

MINOR STORM Allowable Capacity is based on Depth Criterion  
MAJOR STORM Allowable Capacity is based on Depth Criterion

$Q_{allow} =$ 

Minor Storm	Major Storm	
SUMP	SUMP	cfs



## INLET IN A SUMP OR SAG LOCATION

Version 4.06 Released August 2018

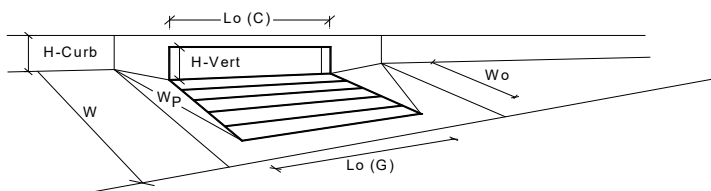

Design Information (Input)	MINOR	MAJOR	
Type of Inlet	CDOT Type R Curb Opening		
Local Depression (additional to continuous gutter depression 'a' from above)			
Number of Unit Inlets (Grate or Curb Opening)	1	1	
Water Depth at Flowline (outside of local depression)	3.8	6.0	inches
<b>Grate Information</b>	MINOR	MAJOR	<input type="checkbox"/> Override Depths
Length of a Unit Grate	N/A	N/A	feet
Width of a Unit Grate	N/A	N/A	feet
Area Opening Ratio for a Grate (typical values 0.15-0.90)	N/A	N/A	
Clogging Factor for a Single Grate (typical value 0.50 - 0.70)	N/A	N/A	
Grate Weir Coefficient (typical value 2.15 - 3.60)	N/A	N/A	
Grate Orifice Coefficient (typical value 0.60 - 0.80)	N/A	N/A	
<b>Curb Opening Information</b>	MINOR	MAJOR	
Length of a Unit Curb Opening	10.00	10.00	feet
Height of Vertical Curb Opening in Inches	6.00	6.00	inches
Height of Curb Orifice Throat in Inches	6.00	6.00	inches
Angle of Throat (see USDCM Figure ST-5)	63.40	63.40	degrees
Side Width for Depression Pan (typically the gutter width of 2 feet)	2.00	2.00	feet
Clogging Factor for a Single Curb Opening (typical value 0.10)	0.10	0.10	
Curb Opening Weir Coefficient (typical value 2.3-3.7)	3.60	3.60	
Curb Opening Orifice Coefficient (typical value 0.60 - 0.70)	0.67	0.67	
<b>Low Head Performance Reduction (Calculated)</b>	MINOR	MAJOR	
Depth for Grate Midwidth	N/A	N/A	ft
Depth for Curb Opening Weir Equation	0.15	0.33	ft
Combination Inlet Performance Reduction Factor for Long Inlets	0.36	0.57	
Curb Opening Performance Reduction Factor for Long Inlets	0.77	0.93	
Grated Inlet Performance Reduction Factor for Long Inlets	N/A	N/A	
<b>Total Inlet Interception Capacity (assumes clogged condition)</b>	MINOR	MAJOR	
<b>Inlet Capacity IS GOOD for Minor and Major Storms(&gt;Q PEAK)</b>	2.1	8.3	cfs
Q <sub>PEAK</sub> REQUIRED =	1.0	2.8	cfs

**ALLOWABLE CAPACITY FOR ONE-HALF OF STREET (Minor & Major Storm)**

(Based on Regulated Criteria for Maximum Allowable Flow Depth and Spread)

Project: **MONUMENT JUNCTION - HWY. 105/JCP INT. IMPS.**  
 Inlet ID: **D4**

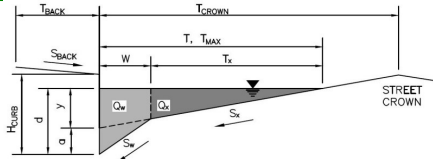

**Gutter Geometry (Enter data in the blue cells)**

Maximum Allowable Width for Spread Behind Curb  
 Side Slope Behind Curb (leave blank for no conveyance credit behind curb)  
 Manning's Roughness Behind Curb (typically between 0.012 and 0.020)  
 Height of Curb at Gutter Flow Line  
 Distance from Curb Face to Street Crown  
 Gutter Width  
 Street Transverse Slope  
 Gutter Cross Slope (typically 2 inches over 24 inches or 0.083 ft/ft)  
 Street Longitudinal Slope - Enter 0 for sump condition  
 Manning's Roughness for Street Section (typically between 0.012 and 0.020)  
 Max. Allowable Spread for Minor & Major Storm  
 Max. Allowable Depth at Gutter Flowline for Minor & Major Storm  
 Allow Flow Depth at Street Crown (leave blank for no)

T <sub>BACK</sub> =	7.0	ft
S <sub>BACK</sub> =	0.020	ft/ft
n <sub>BACK</sub> =	0.016	
H <sub>CURB</sub> =	6.00	inches
T <sub>CROWN</sub> =	50.0	ft
W =	2.00	ft
S <sub>X</sub> =	0.020	ft/ft
S <sub>W</sub> =	0.083	ft/ft
S <sub>O</sub> =	0.035	ft/ft
n <sub>STREET</sub> =	0.016	
T <sub>MAX</sub> =	Minor Storm: 14.0 Major Storm: 25.0	ft
d <sub>MAX</sub> =	Minor Storm: 3.4 Major Storm: 6.0	inches
Q <sub>allow</sub> =	Minor Storm: 3.6 Major Storm: 13.7	cfs

Unresolved:  
Per road profiles in CD set, street slope is approximately 5.5%

**THIS INLET SEEMS TO FALL IN THE LARGE VC AND ACCORDING TO THE CONTOURS IT IS APPROX. 4.6% NOW UPDATED.**

**MINOR STORM Allowable Capacity is based on Depth Criterion**  
**MAJOR STORM Allowable Capacity is based on Depth Criterion**  
 Minor storm max. allowable capacity GOOD - greater than the design flow given on sheet 'Inlet Management'  
 Major storm max. allowable capacity GOOD - greater than the design flow given on sheet 'Inlet Management'

## INLET ON A CONTINUOUS GRADE

Version 4.06 Released August 2018

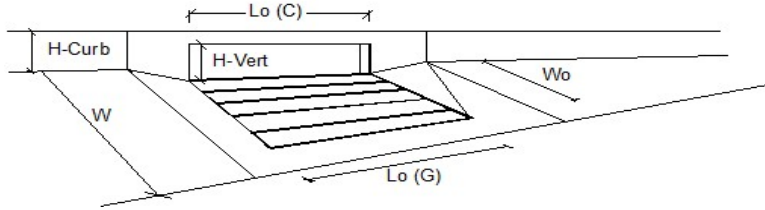

Design Information (Input)	MINOR	MAJOR	
Type of Inlet	CDOT Type R Curb Opening		
Local Depression (additional to continuous gutter depression 'a')	3.0	3.0	inches
Total Number of Units in the Inlet (Grate or Curb Opening)	1	1	
Length of a Single Unit Inlet (Grate or Curb Opening)	5.00	5.00	ft
Width of a Unit Grate (cannot be greater than W, Gutter Width)	N/A	N/A	ft
Clogging Factor for a Single Unit Grate (typical min. value = 0.5)	N/A	N/A	
Clogging Factor for a Single Unit Curb Opening (typical min. value = 0.1)	0.10	0.10	
<b>Street Hydraulics: OK - Q &lt; Allowable Street Capacity*</b>			
Total Inlet Interception Capacity	1.4	2.5	cfs
Total Inlet Carry-Over Flow (flow bypassing inlet)	0.0	1.3	cfs
Capture Percentage = $Q_p/Q_o$ =	97	66	%

**ALLOWABLE CAPACITY FOR ONE-HALF OF STREET (Minor & Major Storm)**

(Based on Regulated Criteria for Maximum Allowable Flow Depth and Spread)

Project: **MONUMENT JUNCTION - HWY. 105/JCP INT. IMPS.**  
 Inlet ID: **D5**

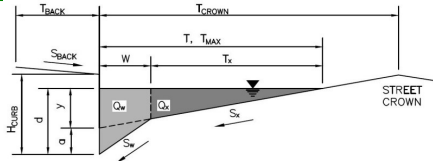

<b>Gutter Geometry (Enter data in the blue cells)</b>													
Maximum Allowable Width for Spread Behind Curb	$T_{BACK} = 4.0$ ft												
Side Slope Behind Curb (leave blank for no conveyance credit behind curb)	$S_{BACK} = 0.250$ ft/ft												
Manning's Roughness Behind Curb (typically between 0.012 and 0.020)	$n_{BACK} = 0.020$												
Height of Curb at Gutter Flow Line	$H_{CURB} = 6.00$ inches												
Distance from Curb Face to Street Crown	$T_{CROWN} = 42.0$ ft												
Gutter Width	$W = 2.00$ ft												
Street Transverse Slope	$S_X = 0.020$ ft/ft												
Gutter Cross Slope (typically 2 inches over 24 inches or 0.083 ft/ft)	$S_W = 0.083$ ft/ft												
Street Longitudinal Slope - Enter 0 for sump condition	$S_D = 0.056$ ft/ft												
Manning's Roughness for Street Section (typically between 0.012 and 0.020)	$n_{STREET} = 0.016$												
Max. Allowable Spread for Minor & Major Storm	<table border="1" style="display: inline-table; border-collapse: collapse;"> <thead> <tr> <th></th> <th>Minor Storm</th> <th>Major Storm</th> <th></th> </tr> </thead> <tbody> <tr> <td><math>T_{MAX} =</math></td> <td>14.0</td> <td>25.0</td> <td>ft</td> </tr> <tr> <td><math>d_{MAX} =</math></td> <td>3.4</td> <td>6.0</td> <td>inches</td> </tr> </tbody> </table>		Minor Storm	Major Storm		$T_{MAX} =$	14.0	25.0	ft	$d_{MAX} =$	3.4	6.0	inches
	Minor Storm	Major Storm											
$T_{MAX} =$	14.0	25.0	ft										
$d_{MAX} =$	3.4	6.0	inches										
Max. Allowable Depth at Gutter Flowline for Minor & Major Storm													
Allow Flow Depth at Street Crown (leave blank for no)	<input type="checkbox"/> <input type="checkbox"/> check = yes												
<b>MINOR STORM Allowable Capacity is based on Depth Criterion</b>													
<b>MAJOR STORM Allowable Capacity is based on Depth Criterion</b>													
<b>Minor storm max. allowable capacity GOOD - greater than the design flow given on sheet 'Inlet Management'</b>													
<b>Major storm max. allowable capacity GOOD - greater than the design flow given on sheet 'Inlet Management'</b>													
	<table border="1" style="display: inline-table; border-collapse: collapse;"> <thead> <tr> <th></th> <th>Minor Storm</th> <th>Major Storm</th> <th></th> </tr> </thead> <tbody> <tr> <td><math>Q_{allow} =</math></td> <td>4.5</td> <td>11.9</td> <td>cfs</td> </tr> </tbody> </table>		Minor Storm	Major Storm		$Q_{allow} =$	4.5	11.9	cfs				
	Minor Storm	Major Storm											
$Q_{allow} =$	4.5	11.9	cfs										

## INLET ON A CONTINUOUS GRADE

Version 4.06 Released August 2018

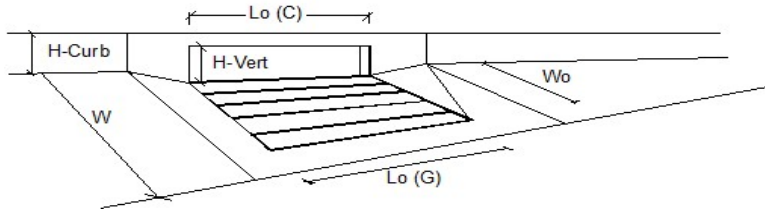

Design Information (Input)	MINOR	MAJOR	
Type of Inlet	CDOT Type R Curb Opening		
Local Depression (additional to continuous gutter depression 'a')	3.0	3.0	inches
Total Number of Units in the Inlet (Grate or Curb Opening)	1	1	
Length of a Single Unit Inlet (Grate or Curb Opening)	10.00	10.00	ft
Width of a Unit Grate (cannot be greater than W, Gutter Width)	N/A	N/A	ft
Clogging Factor for a Single Unit Grate (typical min. value = 0.5)	N/A	N/A	
Clogging Factor for a Single Unit Curb Opening (typical min. value = 0.1)	0.10	0.10	
<b>Street Hydraulics: OK - Q &lt; Allowable Street Capacity*</b>			
Total Inlet Interception Capacity	2.0	4.9	cfs
Total Inlet Carry-Over Flow (flow bypassing inlet)	0.0	0.4	cfs
Capture Percentage = $Q_p/Q_o$ =	100	93	%

**AREA INLET IN A SWALE**

MONUMENT JUNCTION WEST FILING NO. 1

D6

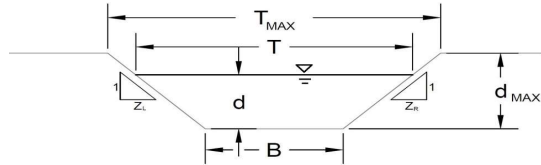

This worksheet uses the NRCS vegetative retardance method to determine Manning's n.  
For more information see Section 7.2.3 of the USDCM.

**Analysis of Trapezoidal Grass-Lined Channel Using SCS Method**

NRCS Vegetal Retardance (A, B, C, D, or E)  
Manning's n (Leave cell D16 blank to manually enter an n value)  
Channel Invert Slope  
Bottom Width  
Left Side Slope  
Right Side Slope

A, B, C, D or E  
n = 0.035  
S<sub>0</sub> = 0.0200 ft/ft  
B = 5.00 ft  
Z1 = 4.00 ft/ft  
Z2 = 4.00 ft/ft

Check one of the following soil types:

Soil Type:	Max. Velocity (V <sub>MAX</sub> )	Max Froude No. (F <sub>MAX</sub> )
Non-Cohesive	5.0 fps	0.60
Cohesive	7.0 fps	0.80
Paved	N/A	N/A

Choose One:  
 Non-Cohesive  
 Cohesive  
 Paved

Max. Allowable Top Width of Channel for Minor & Major Storm  
Max. Allowable Water Depth in Channel for Minor & Major Storm

	Minor Storm	Major Storm	
T <sub>MAX</sub> =	10.00	10.00	feet
d <sub>MAX</sub> =	1.50	1.50	feet

**Allowable Channel Capacity Based On Channel Geometry**

MINOR STORM Allowable Capacity is based on Top Width Criterion  
MAJOR STORM Allowable Capacity is based on Top Width Criterion

	Minor Storm	Major Storm	
Q <sub>allow</sub> =	16.9	16.9	cfs
d <sub>allow</sub> =	0.63	0.63	ft

**Water Depth in Channel Based On Design Peak Flow**

Design Peak Flow  
Water Depth

	Minor Storm	Major Storm	
Q <sub>c</sub> =	4.0	8.0	cfs
d =	0.28	0.42	feet

Minor storm max. allowable capacity GOOD - greater than the design flow given on sheet 'Inlet Management'  
Major storm max. allowable capacity GOOD - greater than the design flow given on sheet 'Inlet Management'

**AREA INLET IN A SWALE**

MONUMENT JUNCTION WEST FILING NO. 1

D6

**Inlet Design Information (Input)**

Type of Inlet:  Inlet Type =

Angle of Inclined Grate (must be <= 30 degrees):  degrees

Width of Grate:  feet

Length of Grate:  feet

Open Area Ratio:

Height of Inclined Grate:  feet

Clogging Factor:

Grate Discharge Coefficient:

Orifice Coefficient:

Weir Coefficient:

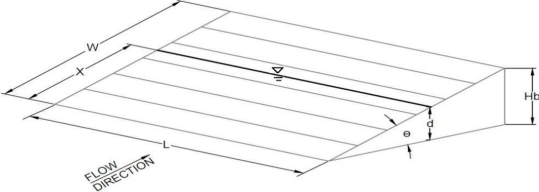

	MINOR	MAJOR	
d =	1.28	1.42	
<b>Q<sub>a</sub> =</b>	<b>16.1</b>	<b>16.9</b>	<b>cfs</b>
Bypassed Flow, Q <sub>b</sub> =	0.0	0.0	cfs
Capture Percentage = Q <sub>a</sub> /Q <sub>o</sub> = C%	100	100	%

Water Depth at Inlet (for depressed inlets, 1 foot is added for depression)

Warning 04: Froude No. exceeds USDCM Volume I recommendation.

**ALLOWABLE CAPACITY FOR ONE-HALF OF STREET (Minor & Major Storm)**

(Based on Regulated Criteria for Maximum Allowable Flow Depth and Spread)

Project: **MONUMENT JUNCTION - HWY. 105/JCP INT. IMPS.**  
 Inlet ID: **D7**

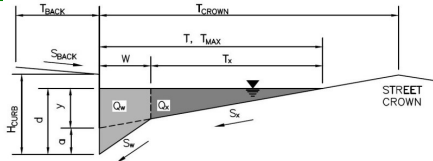

**Gutter Geometry (Enter data in the blue cells)**

Maximum Allowable Width for Spread Behind Curb  
 Side Slope Behind Curb (leave blank for no conveyance credit behind curb)  
 Manning's Roughness Behind Curb (typically between 0.012 and 0.020)

$T_{BACK} = 3.0$  ft  
 $S_{BACK} = 0.100$  ft/ft  
 $n_{BACK} = 0.016$

Height of Curb at Gutter Flow Line  
 Distance from Curb Face to Street Crown  
 Gutter Width  
 Street Transverse Slope  
 Gutter Cross Slope (typically 2 inches over 24 inches or 0.083 ft/ft)  
 Street Longitudinal Slope - Enter 0 for sump condition  
 Manning's Roughness for Street Section (typically between 0.012 and 0.020)

$H_{CURB} = 6.00$  inches  
 $T_{CROWN} = 42.0$  ft  
 $W = 1.00$  ft  
 $S_x = 0.035$  ft/ft  
 $S_w = 0.083$  ft/ft  
 $S_D = 0.040$  ft/ft  
 $n_{STREET} = 0.016$

Max. Allowable Spread for Minor & Major Storm  
 Max. Allowable Depth at Gutter Flowline for Minor & Major Storm  
 Allow Flow Depth at Street Crown (leave blank for no)

	Minor Storm	Major Storm	
$T_{MAX} =$	14.0	25.0	ft
$d_{MAX} =$	3.4	6.0	inches
	<input type="checkbox"/>	<input type="checkbox"/>	check = yes

**MINOR STORM Allowable Capacity is based on Depth Criterion**  
**MAJOR STORM Allowable Capacity is based on Depth Criterion**

	Minor Storm	Major Storm	
$Q_{allow} =$	4.5	11.7	cfs

**WARNING: MINOR STORM max. allowable capacity is less than the design flow given on sheet 'Inlet Management'**  
**WARNING: MAJOR STORM max. allowable capacity is less than the design flow given on sheet 'Inlet Management'**



## INLET ON A CONTINUOUS GRADE

Version 4.06 Released August 2018

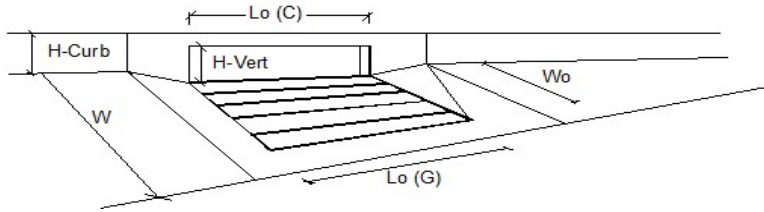

Design Information (Input)	MINOR	MAJOR	
Type of Inlet	CDOT Type R Curb Opening		
Local Depression (additional to continuous gutter depression 'a')	3.0	3.0	inches
Total Number of Units in the Inlet (Grate or Curb Opening)	1	1	
Length of a Single Unit Inlet (Grate or Curb Opening)	10.00	10.00	ft
Width of a Unit Grate (cannot be greater than W, Gutter Width)	N/A	N/A	ft
Clogging Factor for a Single Unit Grate (typical min. value = 0.5)	N/A	N/A	
Clogging Factor for a Single Unit Curb Opening (typical min. value = 0.1)	0.10	0.10	
<b>Street Hydraulics: WARNING: Q &gt; ALLOWABLE Q FOR MINOR &amp; MAJOR STORM</b>			
Total Inlet Interception Capacity	5.4	8.2	cfs
Total Inlet Carry-Over Flow (flow bypassing inlet)	0.6	3.8	cfs
Capture Percentage = $Q_p/Q_o$ =	90	68	%

**ALLOWABLE CAPACITY FOR ONE-HALF OF STREET (Minor & Major Storm)**

(Based on Regulated Criteria for Maximum Allowable Flow Depth and Spread)

Project:  
Inlet ID:

**MONUMENT JUNCTION WEST FILING NO. 1**

**D8**

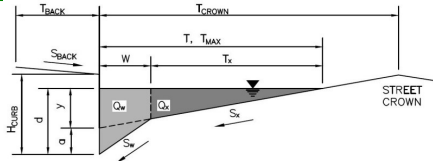

**Gutter Geometry (Enter data in the blue cells)**

Maximum Allowable Width for Spread Behind Curb  
 Side Slope Behind Curb (leave blank for no conveyance credit behind curb)  
 Manning's Roughness Behind Curb (typically between 0.012 and 0.020)  
 Height of Curb at Gutter Flow Line  
 Distance from Curb Face to Street Crown  
 Gutter Width  
 Street Transverse Slope  
 Gutter Cross Slope (typically 2 inches over 24 inches or 0.083 ft/ft)  
 Street Longitudinal Slope - Enter 0 for sump condition  
 Manning's Roughness for Street Section (typically between 0.012 and 0.020)

$T_{BACK} = 3.0$  ft  
 $S_{BACK} = 0.100$  ft/ft  
 $n_{BACK} = 0.016$

$H_{CURB} = 6.00$  inches  
 $T_{CROWN} = 42.0$  ft  
 $W = 1.00$  ft  
 $S_x = 0.045$  ft/ft  
 $S_w = 0.083$  ft/ft  
 $S_D = 0.000$  ft/ft  
 $n_{STREET} = 0.016$

Max. Allowable Spread for Minor & Major Storm  
 Max. Allowable Depth at Gutter Flowline for Minor & Major Storm  
 Check boxes are not applicable in SUMP conditions

	Minor Storm	Major Storm	
$T_{MAX} =$	18.0	18.0	ft
$d_{MAX} =$	6.0	6.0	inches
	<input type="checkbox"/>	<input type="checkbox"/>	

**MINOR STORM Allowable Capacity is based on Depth Criterion**  
**MAJOR STORM Allowable Capacity is based on Depth Criterion**

$Q_{allow} =$ 

Minor Storm	Major Storm	
SUMP	SUMP	cfs

## INLET IN A SUMP OR SAG LOCATION

Version 4.06 Released August 2018

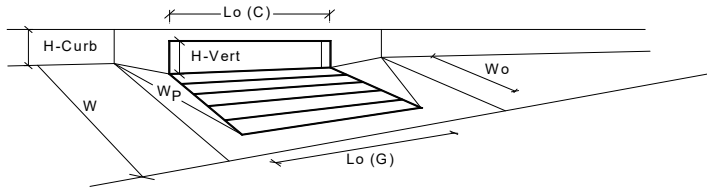

Design Information (Input)	MINOR	MAJOR	
Type of Inlet	CDOT Type R Curb Opening		
Local Depression (additional to continuous gutter depression 'a' from above)			
Number of Unit Inlets (Grate or Curb Opening)	1	1	
Water Depth at Flowline (outside of local depression)	6.0	6.0	inches
<b>Grate Information</b>	MINOR	MAJOR	<input type="checkbox"/> Override Depths
Length of a Unit Grate	N/A	N/A	feet
Width of a Unit Grate	N/A	N/A	feet
Area Opening Ratio for a Grate (typical values 0.15-0.90)	N/A	N/A	
Clogging Factor for a Single Grate (typical value 0.50 - 0.70)	N/A	N/A	
Grate Weir Coefficient (typical value 2.15 - 3.60)	N/A	N/A	
Grate Orifice Coefficient (typical value 0.60 - 0.80)	N/A	N/A	
<b>Curb Opening Information</b>	MINOR	MAJOR	
Length of a Unit Curb Opening	10.00	10.00	feet
Height of Vertical Curb Opening in Inches	6.00	6.00	inches
Height of Curb Orifice Throat in Inches	6.00	6.00	inches
Angle of Throat (see USDCM Figure ST-5)	63.40	63.40	degrees
Side Width for Depression Pan (typically the gutter width of 2 feet)	1.00	1.00	feet
Clogging Factor for a Single Curb Opening (typical value 0.10)	0.10	0.10	
Curb Opening Weir Coefficient (typical value 2.3-3.7)	3.60	3.60	
Curb Opening Orifice Coefficient (typical value 0.60 - 0.70)	0.67	0.67	
<b>Low Head Performance Reduction (Calculated)</b>	MINOR	MAJOR	
Depth for Grate Midwidth	N/A	N/A	ft
Depth for Curb Opening Weir Equation	0.42	0.42	ft
Combination Inlet Performance Reduction Factor for Long Inlets	0.57	0.57	
Curb Opening Performance Reduction Factor for Long Inlets	0.93	0.93	
Grated Inlet Performance Reduction Factor for Long Inlets	N/A	N/A	
<b>Total Inlet Interception Capacity (assumes clogged condition)</b>	MINOR	MAJOR	
Inlet Capacity IS GOOD for Minor and Major Storms(>Q PEAK)	10.0	10.0	cfs
Q PEAK REQUIRED =	3.6	9.8	cfs

**ALLOWABLE CAPACITY FOR ONE-HALF OF STREET (Minor & Major Storm)**

(Based on Regulated Criteria for Maximum Allowable Flow Depth and Spread)

**MONUMENT JUNCTION - HWY. 105/JCP INT. IMPS.**

Project:  
Inlet ID:

D9

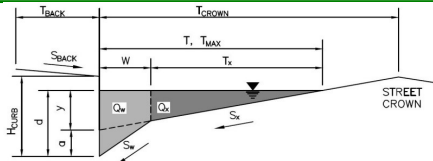

**Gutter Geometry (Enter data in the blue cells)**

Maximum Allowable Width for Spread Behind Curb  
 Side Slope Behind Curb (leave blank for no conveyance credit behind curb)  
 Manning's Roughness Behind Curb (typically between 0.012 and 0.020)  
 Height of Curb at Gutter Flow Line  
 Distance from Curb Face to Street Crown  
 Gutter Width  
 Street Transverse Slope  
 Gutter Cross Slope (typically 2 inches over 24 inches or 0.083 ft/ft)  
 Street Longitudinal Slope - Enter 0 for sump condition  
 Manning's Roughness for Street Section (typically between 0.012 and 0.020)

$T_{BACK} = 10.0$  ft  
 $S_{BACK} = 0.020$  ft/ft  
 $n_{BACK} = 0.016$   
 $H_{CURB} = 6.00$  inches  
 $T_{CROWN} = 25.0$  ft  
 $W = 2.00$  ft  
 $S_X = 0.025$  ft/ft  
 $S_W = 0.083$  ft/ft  
 $S_D = 0.040$  ft/ft  
 $n_{STREET} = 0.016$

Max. Allowable Spread for Minor & Major Storm  
 Max. Allowable Depth at Gutter Flowline for Minor & Major Storm  
 Allow Flow Depth at Street Crown (leave blank for no)

	Minor Storm	Major Storm	
$T_{MAX} =$	14.0	25.0	ft
$d_{MAX} =$	3.4	6.0	inches
	<input type="checkbox"/>	<input type="checkbox"/>	check = yes

**MINOR STORM Allowable Capacity is based on Depth Criterion**  
**MAJOR STORM Allowable Capacity is based on Depth Criterion**

	Minor Storm	Major Storm	
$Q_{allow} =$	3.6	11.4	cfs

**Minor storm max. allowable capacity GOOD - greater than the design flow given on sheet 'Inlet Management'**  
**Major storm max. allowable capacity GOOD - greater than the design flow given on sheet 'Inlet Management'**

## INLET ON A CONTINUOUS GRADE

Version 4.06 Released August 2018

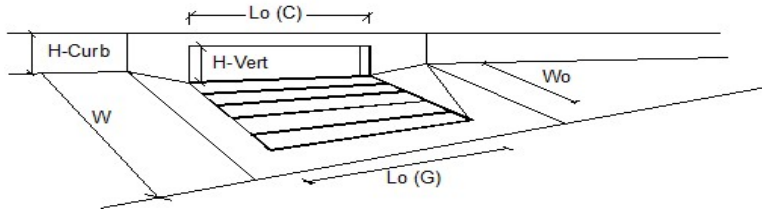

Design Information (Input)	MINOR	MAJOR	
Type of Inlet	CDOT Type R Curb Opening		
Local Depression (additional to continuous gutter depression 'a')	3.0	3.0	inches
Total Number of Units in the Inlet (Grate or Curb Opening)	1	1	
Length of a Single Unit Inlet (Grate or Curb Opening)	10.00	10.00	ft
Width of a Unit Grate (cannot be greater than W, Gutter Width)	N/A	N/A	ft
Clogging Factor for a Single Unit Grate (typical min. value = 0.5)	N/A	N/A	
Clogging Factor for a Single Unit Curb Opening (typical min. value = 0.1)	0.10	0.10	
<b>Street Hydraulics: OK - Q &lt; Allowable Street Capacity*</b>			
Total Inlet Interception Capacity	2.0	4.8	cfs
Total Inlet Carry-Over Flow (flow bypassing inlet)	0.0	0.2	cfs
Capture Percentage = $Q_p/Q_o =$	100	95	%

**ALLOWABLE CAPACITY FOR ONE-HALF OF STREET (Minor & Major Storm)**

(Based on Regulated Criteria for Maximum Allowable Flow Depth and Spread)

MONUMENT JUNCTION - HWY. 105/JCP INT. IMPS.

Project:  
Inlet ID:

D10

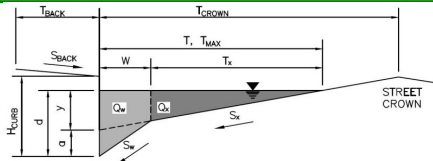

**Gutter Geometry (Enter data in the blue cells)**

Maximum Allowable Width for Spread Behind Curb  
Side Slope Behind Curb (leave blank for no conveyance credit behind curb)  
Manning's Roughness Behind Curb (typically between 0.012 and 0.020)

$T_{BACK} = 10.0$  ft  
 $S_{BACK} = 0.020$  ft/ft  
 $n_{BACK} = 0.016$

Height of Curb at Gutter Flow Line  
Distance from Curb Face to Street Crown  
Gutter Width  
Street Transverse Slope  
Gutter Cross Slope (typically 2 inches over 24 inches or 0.083 ft/ft)  
Street Longitudinal Slope - Enter 0 for sump condition  
Manning's Roughness for Street Section (typically between 0.012 and 0.020)

$H_{CURB} = 6.00$  inches  
 $T_{CROWN} = 48.0$  ft  
 $W = 2.00$  ft  
 $S_x = 0.020$  ft/ft  
 $S_w = 0.083$  ft/ft  
 $S_o = 0.030$  ft/ft  
 $n_{STREET} = 0.016$

Max. Allowable Spread for Minor & Major Storm  
Max. Allowable Depth at Gutter Flowline for Minor & Major Storm  
Allow Flow Depth at Street Crown (leave blank for no)

	Minor Storm	Major Storm	
$T_{MAX} =$	14.0	25.0	ft
$d_{MAX} =$	3.4	6.0	inches
	<input type="checkbox"/>	<input type="checkbox"/>	check = yes

**MINOR STORM Allowable Capacity is based on Depth Criterion**  
**MAJOR STORM Allowable Capacity is based on Depth Criterion**

	Minor Storm	Major Storm	
$Q_{allow} =$	3.3	14.4	cfs

**Minor storm max. allowable capacity GOOD - greater than the design flow given on sheet 'Inlet Management'**  
**Major storm max. allowable capacity GOOD - greater than the design flow given on sheet 'Inlet Management'**

## INLET ON A CONTINUOUS GRADE

Version 4.06 Released August 2018

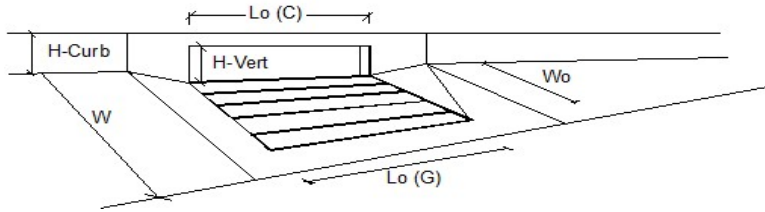

Design Information (Input)	MINOR	MAJOR	
Type of Inlet	CDOT Type R Curb Opening		
Local Depression (additional to continuous gutter depression 'a')	3.0	3.0	inches
Total Number of Units in the Inlet (Grate or Curb Opening)	1	1	
Length of a Single Unit Inlet (Grate or Curb Opening)	10.00	10.00	ft
Width of a Unit Grate (cannot be greater than W, Gutter Width)	N/A	N/A	ft
Clogging Factor for a Single Unit Grate (typical min. value = 0.5)	N/A	N/A	
Clogging Factor for a Single Unit Curb Opening (typical min. value = 0.1)	0.10	0.10	
<b>Street Hydraulics: OK - Q &lt; Allowable Street Capacity*</b>			
Total Inlet Interception Capacity	3.0	5.4	cfs
Total Inlet Carry-Over Flow (flow bypassing inlet)	0.0	0.8	cfs
Capture Percentage = $Q_p/Q_o$ =	100	88	%

**ALLOWABLE CAPACITY FOR ONE-HALF OF STREET (Minor & Major Storm)**

(Based on Regulated Criteria for Maximum Allowable Flow Depth and Spread)

**MONUMENT JUNCTION - HWY. 105/JCP INT. IMPS.**

Project:

Inlet ID:

D11

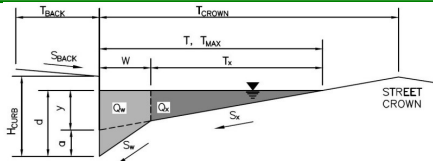

**Gutter Geometry (Enter data in the blue cells)**

Maximum Allowable Width for Spread Behind Curb  
 Side Slope Behind Curb (leave blank for no conveyance credit behind curb)  
 Manning's Roughness Behind Curb (typically between 0.012 and 0.020)  
 Height of Curb at Gutter Flow Line  
 Distance from Curb Face to Street Crown  
 Gutter Width  
 Street Transverse Slope  
 Gutter Cross Slope (typically 2 inches over 24 inches or 0.083 ft/ft)  
 Street Longitudinal Slope - Enter 0 for sump condition  
 Manning's Roughness for Street Section (typically between 0.012 and 0.020)

$T_{BACK} = 5.0$  ft  
 $S_{BACK} = 0.020$  ft/ft  
 $n_{BACK} = 0.016$   
 $H_{CURB} = 6.00$  inches  
 $T_{CROWN} = 48.0$  ft  
 $W = 2.00$  ft  
 $S_X = 0.020$  ft/ft  
 $S_W = 0.083$  ft/ft  
 $S_D = 0.000$  ft/ft  
 $n_{STREET} = 0.016$

Max. Allowable Spread for Minor & Major Storm  
 Max. Allowable Depth at Gutter Flowline for Minor & Major Storm  
 Check boxes are not applicable in SUMP conditions

	Minor Storm	Major Storm	
$T_{MAX} =$	14.0	25.0	ft
$d_{MAX} =$	3.4	6.0	inches
	<input type="checkbox"/>	<input type="checkbox"/>	

**MINOR STORM Allowable Capacity is based on Depth Criterion**  
**MAJOR STORM Allowable Capacity is based on Depth Criterion**

$Q_{allow} =$ 

Minor Storm	Major Storm	
SUMP	SUMP	cfs



## INLET IN A SUMP OR SAG LOCATION

Version 4.06 Released August 2018

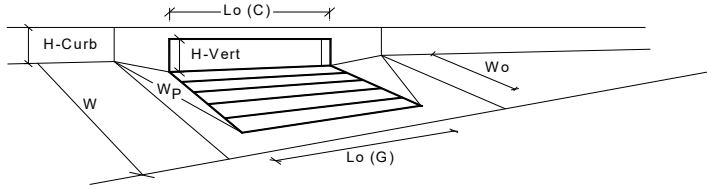

Design Information (Input)	MINOR	MAJOR	
Type of Inlet	CDOT Type R Curb Opening		
Local Depression (additional to continuous gutter depression 'a' from above)			
Number of Unit Inlets (Grate or Curb Opening)			
Water Depth at Flowline (outside of local depression)			
<b>Grate Information</b>	MINOR	MAJOR	
Length of a Unit Grate	N/A	N/A	feet
Width of a Unit Grate	N/A	N/A	feet
Area Opening Ratio for a Grate (typical values 0.15-0.90)	N/A	N/A	
Clogging Factor for a Single Grate (typical value 0.50 - 0.70)	N/A	N/A	
Grate Weir Coefficient (typical value 2.15 - 3.60)	N/A	N/A	
Grate Orifice Coefficient (typical value 0.60 - 0.80)	N/A	N/A	
<b>Curb Opening Information</b>	MINOR	MAJOR	
Length of a Unit Curb Opening	10.00	10.00	feet
Height of Vertical Curb Opening in Inches	6.00	6.00	inches
Height of Curb Orifice Throat in Inches	6.00	6.00	inches
Angle of Throat (see USDCM Figure ST-5)	63.40	63.40	degrees
Side Width for Depression Pan (typically the gutter width of 2 feet)	2.00	2.00	feet
Clogging Factor for a Single Curb Opening (typical value 0.10)	0.10	0.10	
Curb Opening Weir Coefficient (typical value 2.3-3.7)	3.60	3.60	
Curb Opening Orifice Coefficient (typical value 0.60 - 0.70)	0.67	0.67	
<b>Low Head Performance Reduction (Calculated)</b>	MINOR	MAJOR	
Depth for Grate Midwidth	N/A	N/A	ft
Depth for Curb Opening Weir Equation	0.33	0.33	ft
Combination Inlet Performance Reduction Factor for Long Inlets	0.57	0.57	
Curb Opening Performance Reduction Factor for Long Inlets	0.93	0.93	
Grated Inlet Performance Reduction Factor for Long Inlets	N/A	N/A	
<b>Total Inlet Interception Capacity (assumes clogged condition)</b>	MINOR	MAJOR	
Inlet Capacity IS GOOD for Minor and Major Storms(>Q PEAK)	8.3	8.3	cfs
Q PEAK REQUIRED =	1.6	3.8	cfs

# CIRCULAR CONDUIT FLOW (Normal & Critical Depth Computation)

MHFD-Culvert, Version 4.00 (May 2020)

Project: **MONUMENT JUNCTION DEVELOPMENT - HWY. 105 & JCP INT. IMPS.**

Pipe ID: **Pipe Run 1**

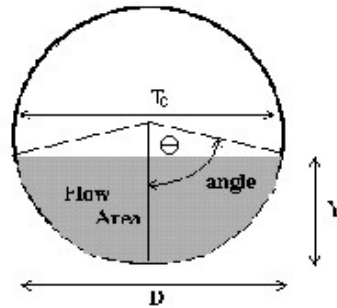

Design Information (Input)	
Pipe Invert Slope	So = 0.0100 ft/ft
Pipe Manning's n-value	n = 0.0130
Pipe Diameter	D = 18.00 inches
Design discharge	Q = 2.50 cfs
Full-Flow Capacity (Calculated)	
Full-flow area	Af = 1.77 sq ft
Full-flow wetted perimeter	Pf = 4.71 ft
Half Central Angle	Theta = 3.14 radians
Full-flow capacity	Qf = 10.53 cfs
Calculation of Normal Flow Condition	
Half Central Angle ( $0 < \text{Theta} < 3.14$ )	Theta = 1.23 radians
Flow area	An = 0.51 sq ft
Top width	Tn = 1.41 ft
Wetted perimeter	Pn = 1.84 ft
Flow depth	Yn = 0.50 ft
Flow velocity	Vn = 4.88 fps
Discharge	Qn = 2.50 cfs
Percent of Full Flow	Flow = 23.7% of full flow
Normal Depth Froude Number	Fr <sub>n</sub> = 1.43 supercritical
Calculation of Critical Flow Condition	
Half Central Angle ( $0 < \text{Theta-c} < 3.14$ )	Theta-c = 1.37 radians
Critical flow area	Ac = 0.66 sq ft
Critical top width	Tc = 1.47 ft
Critical flow depth	Yc = 0.60 ft
Critical flow velocity	Vc = 3.80 fps
Critical Depth Froude Number	Fr <sub>c</sub> = 1.00

# CIRCULAR CONDUIT FLOW (Normal & Critical Depth Computation)

MHFD-Culvert, Version 4.00 (May 2020)

Project: **MONUMENT JUNCTION DEVELOPMENT - HWY. 105 & JCP INT. IMPS.**

Pipe ID: **Pipe Run 1**

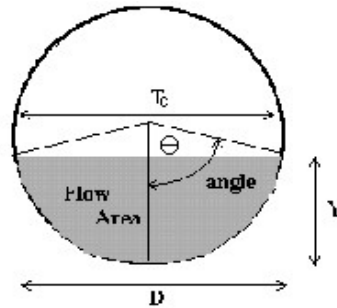

Design Information (Input)	
Pipe Invert Slope	So = 0.0536 ft/ft
Pipe Manning's n-value	n = 0.0130
Pipe Diameter	D = 18.00 inches
Design discharge	Q = 2.50 cfs
Full-Flow Capacity (Calculated)	
Full-flow area	Af = 1.77 sq ft
Full-flow wetted perimeter	Pf = 4.71 ft
Half Central Angle	Theta = 3.14 radians
Full-flow capacity	Qf = 24.38 cfs
Calculation of Normal Flow Condition	
Half Central Angle ( $0 < \text{Theta} < 3.14$ )	Theta = 0.97 radians
Flow area	An = 0.28 sq ft
Top width	Tn = 1.24 ft
Wetted perimeter	Pn = 1.45 ft
Flow depth	Yn = 0.32 ft
Flow velocity	Vn = 8.89 fps
Discharge	Qn = 2.50 cfs
Percent of Full Flow	Flow = 10.3% of full flow
Normal Depth Froude Number	Fr <sub>n</sub> = 3.28 supercritical
Calculation of Critical Flow Condition	
Half Central Angle ( $0 < \text{Theta-c} < 3.14$ )	Theta-c = 1.37 radians
Critical flow area	Ac = 0.66 sq ft
Critical top width	Tc = 1.47 ft
Critical flow depth	Yc = 0.60 ft
Critical flow velocity	Vc = 3.80 fps
Critical Depth Froude Number	Fr <sub>c</sub> = 1.00

# CIRCULAR CONDUIT FLOW (Normal & Critical Depth Computation)

MHFD-Culvert, Version 4.00 (May 2020)

Project: **MONUMENT JUNCTION DEVELOPMENT - HWY. 105 & JCP INT. IMPS.**

Pipe ID: **Pipe Run 2**

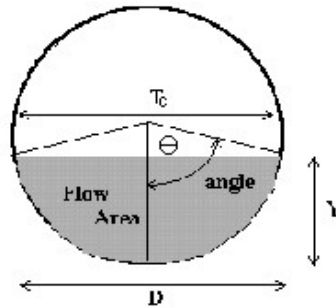

Design Information (Input)	
Pipe Invert Slope	So = 0.0568 ft/ft
Pipe Manning's n-value	n = 0.0130
Pipe Diameter	D = 24.00 inches
Design discharge	Q = 7.00 cfs
Full-Flow Capacity (Calculated)	
Full-flow area	Af = 3.14 sq ft
Full-flow wetted perimeter	Pf = 6.28 ft
Half Central Angle	Theta = 3.14 radians
Full-flow capacity	Qf = 54.06 cfs
Calculation of Normal Flow Condition	
Half Central Angle ( $0 < \theta < 3.14$ )	Theta = 1.03 radians
Flow area	An = 0.59 sq ft
Top width	Tn = 1.72 ft
Wetted perimeter	Pn = 2.06 ft
Flow depth	Yn = 0.49 ft
Flow velocity	Vn = 11.86 fps
Discharge	Qn = 7.00 cfs
Percent of Full Flow	Flow = 12.9% of full flow
Normal Depth Froude Number	Fr <sub>n</sub> = 3.56 supercritical
Calculation of Critical Flow Condition	
Half Central Angle ( $0 < \theta_c < 3.14$ )	Theta-c = 1.51 radians
Critical flow area	Ac = 1.45 sq ft
Critical top width	Tc = 2.00 ft
Critical flow depth	Yc = 0.94 ft
Critical flow velocity	Vc = 4.83 fps
Critical Depth Froude Number	Fr <sub>c</sub> = 1.00

# CIRCULAR CONDUIT FLOW (Normal & Critical Depth Computation)

MHFD-Culvert, Version 4.00 (May 2020)

Project: **MONUMENT JUNCTION DEVELOPMENT - HWY. 105 & JCP INT. IMPS.**

Pipe ID: **Pipe Run 3**

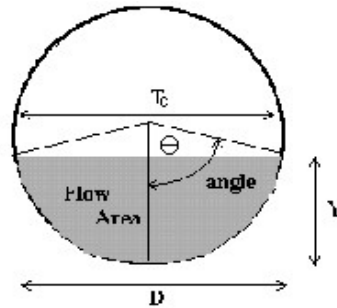

Design Information (Input)	
Pipe Invert Slope	So = 0.0100 ft/ft
Pipe Manning's n-value	n = 0.0130
Pipe Diameter	D = 18.00 inches
Design discharge	Q = 8.00 cfs
Full-Flow Capacity (Calculated)	
Full-flow area	Af = 1.77 sq ft
Full-flow wetted perimeter	Pf = 4.71 ft
Half Central Angle	Theta = 3.14 radians
Full-flow capacity	Qf = 10.53 cfs
Calculation of Normal Flow Condition	
Half Central Angle ( $0 < \theta < 3.14$ )	Theta = 1.88 radians
Flow area	An = 1.22 sq ft
Top width	Tn = 1.43 ft
Wetted perimeter	Pn = 2.82 ft
Flow depth	Yn = 0.98 ft
Flow velocity	Vn = 6.56 fps
Discharge	Qn = 8.00 cfs
Percent of Full Flow	Flow = 76.0% of full flow
Normal Depth Froude Number	Fr <sub>n</sub> = 1.25 supercritical
Calculation of Critical Flow Condition	
Half Central Angle ( $0 < \theta_c < 3.14$ )	Theta-c = 2.05 radians
Critical flow area	Ac = 1.38 sq ft
Critical top width	Tc = 1.33 ft
Critical flow depth	Yc = 1.10 ft
Critical flow velocity	Vc = 5.78 fps
Critical Depth Froude Number	Fr <sub>c</sub> = 1.00

# CIRCULAR CONDUIT FLOW (Normal & Critical Depth Computation)

MHFD-Culvert, Version 4.00 (May 2020)

Project: **MONUMENT JUNCTION DEVELOPMENT - HWY. 105 & JCP INT. IMPS.**

Pipe ID: **Pipe Run 4**

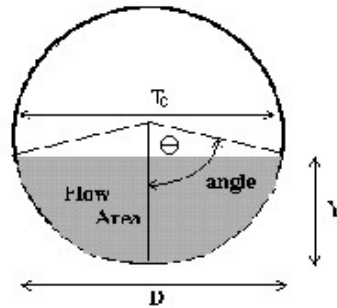

Design Information (Input)	
Pipe Invert Slope	So = 0.0763 ft/ft
Pipe Manning's n-value	n = 0.0130
Pipe Diameter	D = 24.00 inches
Design discharge	Q = 14.00 cfs
Full-Flow Capacity (Calculated)	
Full-flow area	Af = 3.14 sq ft
Full-flow wetted perimeter	Pf = 6.28 ft
Half Central Angle	Theta = 3.14 radians
Full-flow capacity	Qf = 62.66 cfs
Calculation of Normal Flow Condition	
Half Central Angle ( $0 < \theta < 3.14$ )	Theta = 1.21 radians
Flow area	An = 0.87 sq ft
Top width	Tn = 1.87 ft
Wetted perimeter	Pn = 2.41 ft
Flow depth	Yn = 0.64 ft
Flow velocity	Vn = 16.07 fps
Discharge	Qn = 14.00 cfs
Percent of Full Flow	Flow = 22.3% of full flow
Normal Depth Froude Number	Fr <sub>n</sub> = 4.15 supercritical
Calculation of Critical Flow Condition	
Half Central Angle ( $0 < \theta_c < 3.14$ )	Theta-c = 1.93 radians
Critical flow area	Ac = 2.25 sq ft
Critical top width	Tc = 1.88 ft
Critical flow depth	Yc = 1.35 ft
Critical flow velocity	Vc = 6.22 fps
Critical Depth Froude Number	Fr <sub>c</sub> = 1.00

# CIRCULAR CONDUIT FLOW (Normal & Critical Depth Computation)

MHFD-Culvert, Version 4.00 (May 2020)

Project: **MONUMENT JUNCTION DEVELOPMENT - HWY. 105 & JCP INT. IMPS.**

Pipe ID: **Pipe Run 5**

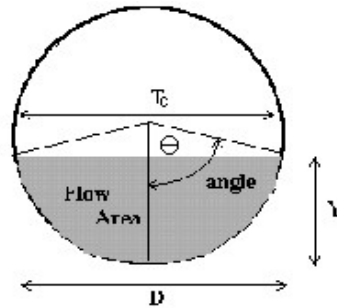

Design Information (Input)	
Pipe Invert Slope	So = 0.0448 ft/ft
Pipe Manning's n-value	n = 0.0130
Pipe Diameter	D = 18.00 inches
Design discharge	Q = 8.00 cfs
Full-Flow Capacity (Calculated)	
Full-flow area	Af = 1.77 sq ft
Full-flow wetted perimeter	Pf = 4.71 ft
Half Central Angle	Theta = 3.14 radians
Full-flow capacity	Qf = 22.29 cfs
Calculation of Normal Flow Condition	
Half Central Angle ( $0 < \theta < 3.14$ )	Theta = 1.40 radians
Flow area	An = 0.69 sq ft
Top width	Tn = 1.48 ft
Wetted perimeter	Pn = 2.10 ft
Flow depth	Yn = 0.62 ft
Flow velocity	Vn = 11.58 fps
Discharge	Qn = 8.00 cfs
Percent of Full Flow	Flow = 35.9% of full flow
Normal Depth Froude Number	Fr <sub>n</sub> = 2.98 supercritical
Calculation of Critical Flow Condition	
Half Central Angle ( $0 < \theta_c < 3.14$ )	Theta-c = 2.05 radians
Critical flow area	Ac = 1.38 sq ft
Critical top width	Tc = 1.33 ft
Critical flow depth	Yc = 1.10 ft
Critical flow velocity	Vc = 5.78 fps
Critical Depth Froude Number	Fr <sub>c</sub> = 1.00

# CIRCULAR CONDUIT FLOW (Normal & Critical Depth Computation)

MHFD-Culvert, Version 4.00 (May 2020)

Project: **MONUMENT JUNCTION DEVELOPMENT - HWY. 105 & JCP INT. IMPS.**

Pipe ID: **Pipe Run 6**

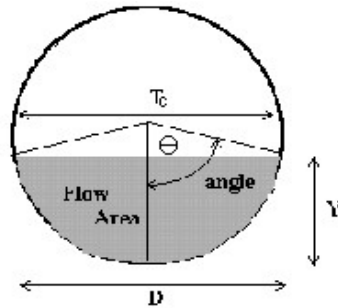

Design Information (Input)	
Pipe Invert Slope	So = 0.0307 ft/ft
Pipe Manning's n-value	n = 0.0130
Pipe Diameter	D = 24.00 inches
Design discharge	Q = 17.00 cfs
Full-Flow Capacity (Calculated)	
Full-flow area	Af = 3.14 sq ft
Full-flow wetted perimeter	Pf = 6.28 ft
Half Central Angle	Theta = 3.14 radians
Full-flow capacity	Qf = 39.74 cfs
Calculation of Normal Flow Condition	
Half Central Angle ( $0 < \theta < 3.14$ )	Theta = 1.48 radians
Flow area	An = 1.40 sq ft
Top width	Tn = 1.99 ft
Wetted perimeter	Pn = 2.97 ft
Flow depth	Yn = 0.91 ft
Flow velocity	Vn = 12.16 fps
Discharge	Qn = 17.00 cfs
Percent of Full Flow	Flow = 42.8% of full flow
Normal Depth Froude Number	Fr <sub>n</sub> = 2.56 supercritical
Calculation of Critical Flow Condition	
Half Central Angle ( $0 < \theta_c < 3.14$ )	Theta-c = 2.08 radians
Critical flow area	Ac = 2.50 sq ft
Critical top width	Tc = 1.75 ft
Critical flow depth	Yc = 1.49 ft
Critical flow velocity	Vc = 6.79 fps
Critical Depth Froude Number	Fr <sub>c</sub> = 1.00



# CIRCULAR CONDUIT FLOW (Normal & Critical Depth Computation)

MHFD-Culvert, Version 4.00 (May 2020)

Project: **MONUMENT JUNCTION DEVELOPMENT - HWY. 105 & JCP INT. IMPS.**

Pipe ID: **Pipe Run 7**

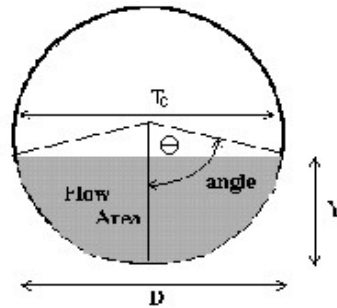

Design Information (Input)	
Pipe Invert Slope	So = 0.1140 ft/ft
Pipe Manning's n-value	n = 0.0130
Pipe Diameter	D = 24.00 inches
Design discharge	Q = 20.00 cfs
Full-Flow Capacity (Calculated)	
Full-flow area	Af = 3.14 sq ft
Full-flow wetted perimeter	Pf = 6.28 ft
Half Central Angle	Theta = 3.14 radians
Full-flow capacity	Qf = 76.59 cfs
Calculation of Normal Flow Condition	
Half Central Angle ( $0 < \theta < 3.14$ )	Theta = 1.26 radians
Flow area	An = 0.98 sq ft
Top width	Tn = 1.91 ft
Wetted perimeter	Pn = 2.53 ft
Flow depth	Yn = 0.70 ft
Flow velocity	Vn = 20.51 fps
Discharge	Qn = 20.00 cfs
Percent of Full Flow	Flow = 26.1% of full flow
Normal Depth Froude Number	Fr <sub>n</sub> = 5.05 supercritical
Calculation of Critical Flow Condition	
Half Central Angle ( $0 < \theta_c < 3.14$ )	Theta-c = 2.22 radians
Critical flow area	Ac = 2.70 sq ft
Critical top width	Tc = 1.59 ft
Critical flow depth	Yc = 1.61 ft
Critical flow velocity	Vc = 7.40 fps
Critical Depth Froude Number	Fr <sub>c</sub> = 1.00

Per ECM section 3.3.1.J.8 maximum storm sewer velocity is 18 fps. Please revise

**REVISED**

# CIRCULAR CONDUIT FLOW (Normal & Critical Depth Computation)

MHFD-Culvert, Version 4.00 (May 2020)

Project: **MONUMENT JUNCTION DEVELOPMENT - HWY. 105 & JCP INT. IMPS.**

Pipe ID: **Pipe Run 8**

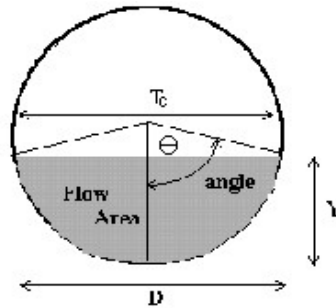

Design Information (Input)	
Pipe Invert Slope	So = 0.0065 ft/ft
Pipe Manning's n-value	n = 0.0130
Pipe Diameter	D = 30.00 inches
Design discharge	Q = 32.00 cfs
Full-Flow Capacity (Calculated)	
Full-flow area	Af = 4.91 sq ft
Full-flow wetted perimeter	Pf = 7.85 ft
Half Central Angle	Theta = 3.14 radians
Full-flow capacity	Qf = 33.16 cfs
Calculation of Normal Flow Condition	
Half Central Angle ( $0 < \theta < 3.14$ )	Theta = 2.19 radians
Flow area	An = 4.16 sq ft
Top width	Tn = 2.04 ft
Wetted perimeter	Pn = 5.47 ft
Flow depth	Yn = 1.97 ft
Flow velocity	Vn = 7.69 fps
Discharge	Qn = 32.00 cfs
Percent of Full Flow	Flow = 96.5% of full flow
Normal Depth Froude Number	Fr <sub>n</sub> = 0.95 subcritical
Calculation of Critical Flow Condition	
Half Central Angle ( $0 < \theta_c < 3.14$ )	Theta-c = 2.14 radians
Critical flow area	Ac = 4.06 sq ft
Critical top width	Tc = 2.10 ft
Critical flow depth	Yc = 1.93 ft
Critical flow velocity	Vc = 7.88 fps
Critical Depth Froude Number	Fr <sub>c</sub> = 1.00

# CIRCULAR CONDUIT FLOW (Normal & Critical Depth Computation)

MHFD-Culvert, Version 4.00 (May 2020)

Project: **MONUMENT JUNCTION DEVELOPMENT - HWY. 105 & JCP INT. IMPS.**

Pipe ID: **Pipe Run 9**

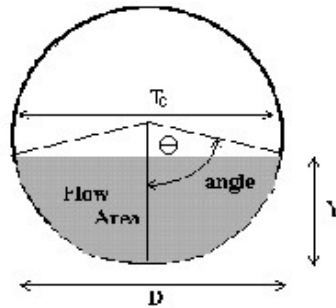

Design Information (Input)	
Pipe Invert Slope	So = 0.0100 ft/ft
Pipe Manning's n-value	n = 0.0130
Pipe Diameter	D = 18.00 inches
Design discharge	Q = 5.00 cfs
Full-Flow Capacity (Calculated)	
Full-flow area	Af = 1.77 sq ft
Full-flow wetted perimeter	Pf = 4.71 ft
Half Central Angle	Theta = 3.14 radians
Full-flow capacity	Qf = 10.53 cfs
Calculation of Normal Flow Condition	
Half Central Angle ( $0 < \theta < 3.14$ )	Theta = 1.54 radians
Flow area	An = 0.85 sq ft
Top width	Tn = 1.50 ft
Wetted perimeter	Pn = 2.31 ft
Flow depth	Yn = 0.73 ft
Flow velocity	Vn = 5.88 fps
Discharge	Qn = 5.00 cfs
Percent of Full Flow	Flow = 47.5% of full flow
Normal Depth Froude Number	Fr <sub>n</sub> = 1.38 supercritical
Calculation of Critical Flow Condition	
Half Central Angle ( $0 < \theta_c < 3.14$ )	Theta-c = 1.72 radians
Critical flow area	Ac = 1.05 sq ft
Critical top width	Tc = 1.48 ft
Critical flow depth	Yc = 0.86 ft
Critical flow velocity	Vc = 4.77 fps
Critical Depth Froude Number	Fr <sub>c</sub> = 1.00

# CIRCULAR CONDUIT FLOW (Normal & Critical Depth Computation)

MHFD-Culvert, Version 4.00 (May 2020)

Project: **MONUMENT JUNCTION DEVELOPMENT - HWY. 105 & JCP INT. IMPS.**

Pipe ID: **Pipe Run 10**

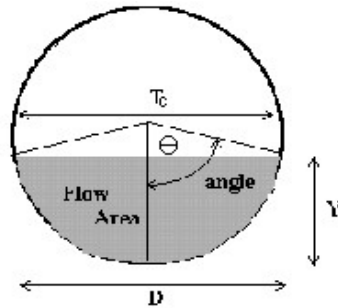

Design Information (Input)	
Pipe Invert Slope	So = 0.0080 ft/ft
Pipe Manning's n-value	n = 0.0130
Pipe Diameter	D = 30.00 inches
Design discharge	Q = 36.00 cfs
Full-Flow Capacity (Calculated)	
Full-flow area	Af = 4.91 sq ft
Full-flow wetted perimeter	Pf = 7.85 ft
Half Central Angle	Theta = 3.14 radians
Full-flow capacity	Qf = 36.79 cfs
Calculation of Normal Flow Condition	
Half Central Angle ( $0 < \theta < 3.14$ )	Theta = 2.22 radians
Flow area	An = 4.21 sq ft
Top width	Tn = 2.00 ft
Wetted perimeter	Pn = 5.54 ft
Flow depth	Yn = 2.00 ft
Flow velocity	Vn = 8.54 fps
Discharge	Qn = 36.00 cfs
Percent of Full Flow	Flow = 97.9% of full flow
Normal Depth Froude Number	Fr <sub>n</sub> = 1.04 supercritical
Calculation of Critical Flow Condition	
Half Central Angle ( $0 < \theta_c < 3.14$ )	Theta-c = 2.25 radians
Critical flow area	Ac = 4.28 sq ft
Critical top width	Tc = 1.95 ft
Critical flow depth	Yc = 2.03 ft
Critical flow velocity	Vc = 8.41 fps
Critical Depth Froude Number	Fr <sub>c</sub> = 1.00

# DETERMINATION OF CULVERT HEADWATER AND OUTLET PROTECTION

*MHFD-Culvert, Version 4.00 (May 2020)*

**Project:** MONUMENT JUNCTION - HWY. 105 / JCP INT. IMPROVEMENTS  
**ID:** 30" RCP STORMWATER QUALITY OUTFALL

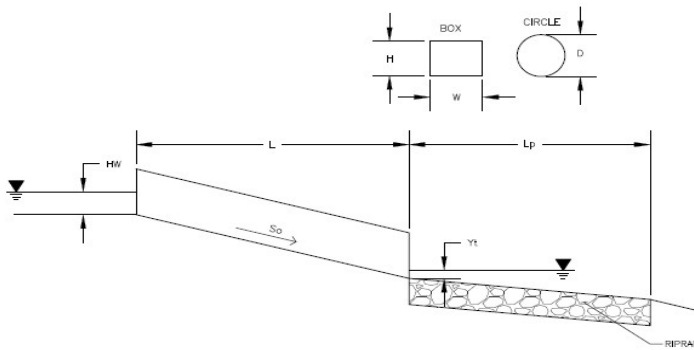

**Soil Type:**

Choose One:

- Sandy  
 Non-Sandy

**Design Information:**

Design Discharge	Q = <input type="text" value="36"/> cfs
<b>Circular Culvert:</b>	
Barrel Diameter in Inches	D = <input type="text" value="30"/> inches
Inlet Edge Type (Choose from pull-down list)	Square Edge Projecting
<b>OR:</b>	
<b>Box Culvert:</b>	
Barrel Height (Rise) in Feet	H (Rise) = <input type="text"/> ft
Barrel Width (Span) in Feet	W (Span) = <input type="text"/> ft
Inlet Edge Type (Choose from pull-down list)	
Number of Barrels	# Barrels = <input type="text" value="1"/>
Inlet Elevation	Elev IN = <input type="text" value="7013.25"/> ft
Outlet Elevation <b>OR</b> Slope	Elev OUT = <input type="text" value="7012.75"/> ft
Culvert Length	L = <input type="text" value="100"/> ft
Manning's Roughness	n = <input type="text" value="0.013"/>
Bend Loss Coefficient	k <sub>b</sub> = <input type="text" value="0"/>
Exit Loss Coefficient	k <sub>x</sub> = <input type="text" value="1"/>
Tailwater Surface Elevation	Y <sub>t</sub> Elevation = <input type="text"/> ft
Max Allowable Channel Velocity	V = <input type="text" value="7"/> ft/s

**Calculated Results:**

Culvert Cross Sectional Area Available	A = <input type="text" value="4.91"/> ft <sup>2</sup>
Culvert Normal Depth	Y <sub>n</sub> = <input type="text" value="2.50"/> ft
Culvert Critical Depth	Y <sub>c</sub> = <input type="text" value="2.03"/> ft
Froude Number	Fr = <input type="text" value="-"/> <b>Pressure flow!</b>
Entrance Loss Coefficient	k <sub>e</sub> = <input type="text" value="0.20"/>
Friction Loss Coefficient	k <sub>f</sub> = <input type="text" value="0.92"/>
Sum of All Loss Coefficients	k <sub>s</sub> = <input type="text" value="2.12"/> ft

**Headwater:**

Inlet Control Headwater	HW <sub>I</sub> = <input type="text" value="3.85"/> ft
Outlet Control Headwater	HW <sub>O</sub> = <input type="text" value="3.54"/> ft
<b>Design Headwater Elevation</b>	<b>HW = <input type="text" value="7017.10"/> ft</b>
<b>Headwater/Diameter <b>OR</b> Headwater/Rise Ratio</b>	<b>HW/D = <input type="text" value="1.54"/> <b>HW/D &gt; 1.5!</b></b>

**Outlet Protection:**

Flow/(Diameter <sup>2.5</sup> )	Q/D <sup>2.5</sup> = <input type="text" value="3.64"/> ft <sup>0.5</sup> /s
Tailwater Surface Height	Y <sub>t</sub> = <input type="text" value="1.00"/> ft
Tailwater/Diameter	Y <sub>t</sub> /D = <input type="text" value="0.40"/>
Expansion Factor	1/(2*tan(θ)) = <input type="text" value="3.82"/>
Flow Area at Max Channel Velocity	A <sub>t</sub> = <input type="text" value="5.14"/> ft <sup>2</sup>
Width of Equivalent Conduit for Multiple Barrels	W <sub>eq</sub> = <input type="text" value="-"/> ft
<b>Length of Riprap Protection</b>	<b>L<sub>p</sub> = <input type="text" value="11"/> ft</b>
<b>Width of Riprap Protection at Downstream End</b>	<b>T = <input type="text" value="6"/> ft</b>
Adjusted Diameter for Supercritical Flow	Da = <input type="text" value="-"/> ft
Minimum Theoretical Riprap Size	d <sub>50</sub> min = <input type="text" value="8"/> in
Nominal Riprap Size	d <sub>50</sub> nominal = <input type="text" value="9"/> in
<b>MHFD Riprap Type</b>	<b>Type = <input type="text" value="L"/></b>

# CIRCULAR CONDUIT FLOW (Normal & Critical Depth Computation)

MHFD-Culvert, Version 4.00 (May 2020)

Project: **MONUMENT JUNCTION DEVELOPMENT - HWY. 105 & JCP INT. IMPS.**

Pipe ID: **Pipe Run 11**

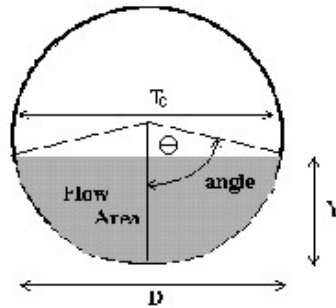

Design Information (Input)	
Pipe Invert Slope	So = 0.0100 ft/ft
Pipe Manning's n-value	n = 0.0130
Pipe Diameter	D = 18.00 inches
Design discharge	Q = 4.00 cfs
Full-Flow Capacity (Calculated)	
Full-flow area	Af = 1.77 sq ft
Full-flow wetted perimeter	Pf = 4.71 ft
Half Central Angle	Theta = 3.14 radians
Full-flow capacity	Qf = 10.53 cfs
Calculation of Normal Flow Condition	
Half Central Angle ( $0 < \theta < 3.14$ )	Theta = 1.42 radians
Flow area	An = 0.72 sq ft
Top width	Tn = 1.48 ft
Wetted perimeter	Pn = 2.14 ft
Flow depth	Yn = 0.64 ft
Flow velocity	Vn = 5.55 fps
Discharge	Qn = 4.00 cfs
Percent of Full Flow	Flow = 38.0% of full flow
Normal Depth Froude Number	Fr <sub>n</sub> = 1.40 supercritical
Calculation of Critical Flow Condition	
Half Central Angle ( $0 < \theta_c < 3.14$ )	Theta-c = 1.59 radians
Critical flow area	Ac = 0.91 sq ft
Critical top width	Tc = 1.50 ft
Critical flow depth	Yc = 0.77 ft
Critical flow velocity	Vc = 4.41 fps
Critical Depth Froude Number	Fr <sub>c</sub> = 1.00

# CIRCULAR CONDUIT FLOW (Normal & Critical Depth Computation)

MHFD-Culvert, Version 4.00 (May 2020)

Project: **MONUMENT JUNCTION DEVELOPMENT - HWY. 105 & JCP INT. IMPS.**

Pipe ID: **EXIST. 36" RCP CULVERT**

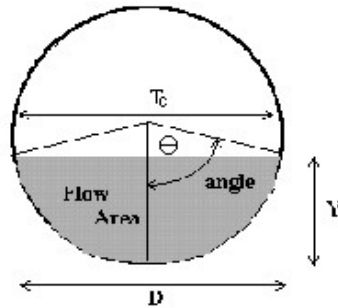

Design Information (Input)	
Pipe Invert Slope	So = 0.0100 ft/ft
Pipe Manning's n-value	n = 0.0130
Pipe Diameter	D = 36.00 inches
Design discharge	Q = 40.00 cfs
Full-Flow Capacity (Calculated)	
Full-flow area	Af = 7.07 sq ft
Full-flow wetted perimeter	Pf = 9.42 ft
Half Central Angle	Theta = 3.14 radians
Full-flow capacity	Qf = 66.88 cfs
Calculation of Normal Flow Condition	
Half Central Angle ( $0 < \text{Theta} < 3.14$ )	Theta = 1.69 radians
Flow area	An = 4.05 sq ft
Top width	Tn = 2.98 ft
Wetted perimeter	Pn = 5.06 ft
Flow depth	Yn = 1.67 ft
Flow velocity	Vn = 9.88 fps
Discharge	Qn = 40.00 cfs
Percent of Full Flow	Flow = 59.8% of full flow
Normal Depth Froude Number	Fr <sub>n</sub> = 1.49 supercritical
Calculation of Critical Flow Condition	
Half Central Angle ( $0 < \text{Theta-c} < 3.14$ )	Theta-c = 1.95 radians
Critical flow area	Ac = 5.17 sq ft
Critical top width	Tc = 2.78 ft
Critical flow depth	Yc = 2.06 ft
Critical flow velocity	Vc = 7.73 fps
Critical Depth Froude Number	Fr <sub>c</sub> = 1.00

# DETERMINATION OF CULVERT HEADWATER AND OUTLET PROTECTION

*MHFD-Culvert, Version 4.00 (May 2020)*

**Project:** MONUMENT JUNCTION - HWY. 105 / JCP INT. IMPROVEMENTS

**ID:** Exist. 36" RCP CDOT Outfall

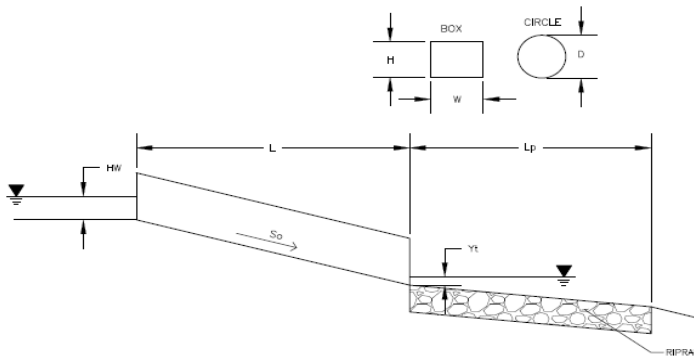

**Soil Type:**

Choose One:

- Sandy  
 Non-Sandy

**Supercritical Flow! Using Adjusted Diameter to calculate protection type.**

**Design Information:**

Design Discharge	Q = <input type="text" value="25.2"/> cfs
<b>Circular Culvert:</b>	
Barrel Diameter in Inches	D = <input type="text" value="36"/> inches
Inlet Edge Type (Choose from pull-down list)	Square Edge Projecting
<b>OR:</b>	
<b>Box Culvert:</b>	
Barrel Height (Rise) in Feet	H (Rise) = <input type="text"/> ft
Barrel Width (Span) in Feet	W (Span) = <input type="text"/> ft
Inlet Edge Type (Choose from pull-down list)	
Number of Barrels	# Barrels = <input type="text" value="1"/>
Inlet Elevation	Elev IN = <input type="text" value="7003.8"/> ft
Outlet Elevation <b>OR</b> Slope	So = <input type="text" value="0.01"/> ft/ft
Culvert Length	L = <input type="text" value="116"/> ft
Manning's Roughness	n = <input type="text" value="0.013"/>
Bend Loss Coefficient	k <sub>b</sub> = <input type="text" value="0"/>
Exit Loss Coefficient	k <sub>x</sub> = <input type="text" value="1"/>
Tailwater Surface Elevation	Y <sub>t</sub> , Elevation = <input type="text"/> ft
Max Allowable Channel Velocity	V = <input type="text" value="7"/> ft/s

**Calculated Results:**

Culvert Cross Sectional Area Available	A = <input type="text" value="7.07"/> ft <sup>2</sup>
Culvert Normal Depth	Y <sub>n</sub> = <input type="text" value="1.28"/> ft
Culvert Critical Depth	Y <sub>c</sub> = <input type="text" value="1.62"/> ft
Froude Number	Fr = <input type="text" value="1.58"/> <b>Supercritical!</b>
Entrance Loss Coefficient	k <sub>e</sub> = <input type="text" value="0.20"/>
Friction Loss Coefficient	k <sub>f</sub> = <input type="text" value="0.83"/>
Sum of All Loss Coefficients	k <sub>s</sub> = <input type="text" value="2.03"/> ft

**Headwater:**

Inlet Control Headwater	HW <sub>I</sub> = <input type="text" value="2.40"/> ft
Outlet Control Headwater	HW <sub>O</sub> = <input type="text" value="N/A"/> ft
<b>Design Headwater Elevation</b>	<b>HW = <input type="text" value="7006.20"/> ft</b>
<b>Headwater/Diameter OR Headwater/Rise Ratio</b>	<b>HW/D = <input type="text" value="0.80"/></b>

**Outlet Control Headwater Approximation Method Inaccurate for Low Flow - Backwater Calculations Required**

**Outlet Protection:**

Flow/(Diameter <sup>2.5</sup> )	Q/D <sup>2.5</sup> = <input type="text" value="1.62"/> ft <sup>0.5</sup> /s
Tailwater Surface Height	Y <sub>t</sub> = <input type="text" value="1.20"/> ft
Tailwater/Diameter	Y <sub>t</sub> /D = <input type="text" value="0.40"/>
Expansion Factor	1/(2*tan(Θ)) = <input type="text" value="6.11"/>
Flow Area at Max Channel Velocity	A <sub>t</sub> = <input type="text" value="3.60"/> ft <sup>2</sup>
Width of Equivalent Conduit for Multiple Barrels	W <sub>eq</sub> = <input type="text" value="-"/> ft
<b>Length of Riprap Protection</b>	<b>L<sub>p</sub> = <input type="text" value="9"/> ft</b>
<b>Width of Riprap Protection at Downstream End</b>	<b>T = <input type="text" value="5"/> ft</b>
Adjusted Diameter for Supercritical Flow	Da = <input type="text" value="2.14"/> ft
Minimum Theoretical Riprap Size	d <sub>50</sub> min = <input type="text" value="4"/> in
Nominal Riprap Size	d <sub>50</sub> nominal = <input type="text" value="6"/> in
<b>MHFD Riprap Type</b>	<b>Type = <input type="text" value="VL"/></b>



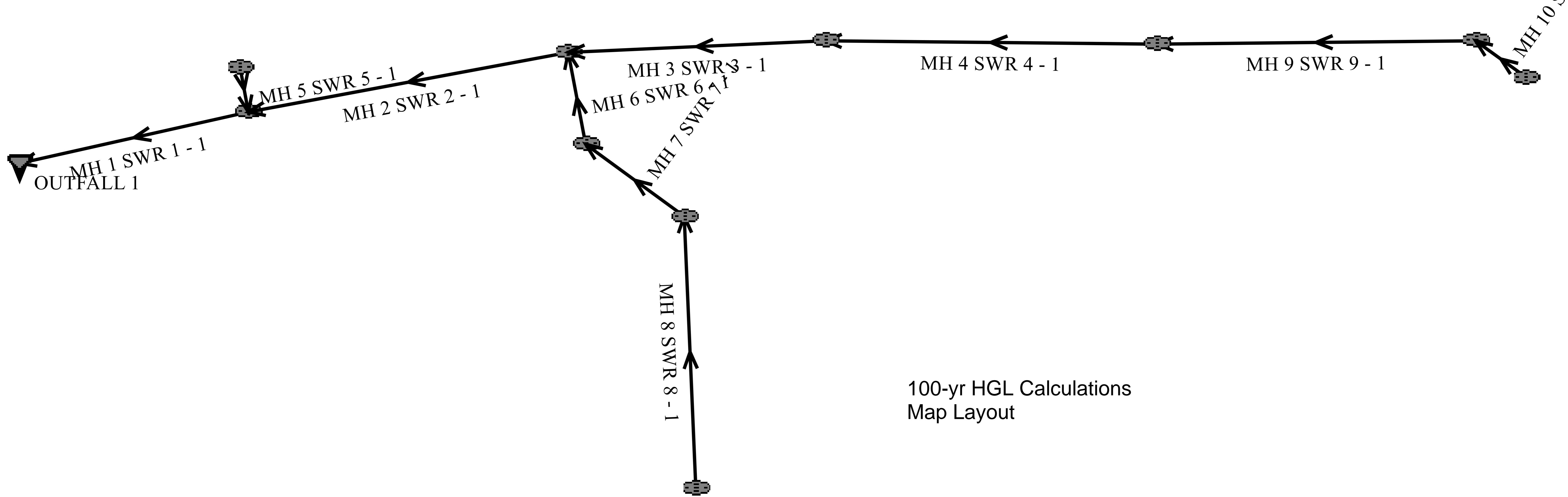

100-yr HGL Calculations  
Map Layout

# System Input Summary

## Rainfall Parameters

**Rainfall Return Period:** 100

**Rainfall Calculation Method:** Table

<b>Time</b>	<b>Intensity</b>
<b>5</b>	8.68
<b>10</b>	6.93
<b>20</b>	5.19
<b>30</b>	4.16
<b>40</b>	3.44
<b>60</b>	2.42
<b>120</b>	0.67

## Rational Method Constraints

**Minimum Urban Runoff Coeff.:** 0.20

**Maximum Rural Overland Len. (ft):** 500

**Maximum Urban Overland Len. (ft):** 300

**Used UDFCD Tc. Maximum:** Yes

## Sizer Constraints

**Minimum Sewer Size (in):** 18.00

**Maximum Depth to Rise Ratio:** 0.90



## Manhole Output Summary:

Element Name	Local Contribution					Total Design Flow				Comment
	Overland Time (min)	Gutter Time (min)	Basin Tc (min)	Intensity (in/hr)	Local Contrib (cfs)	Coeff. Area	Intensity (in/hr)	Manhole Tc (min)	Peak Flow (cfs)	
OUTFALL 1	0.00	0.00	0.00	0.00	0.00	54.92	0.66	0.38	36.00	
MH 1 SWR 1 - 1	0.00	0.00	0.00	0.00	0.00	0.00	0.00	0.00	36.00	
MH 5 SWR 5 - 1	0.00	0.00	0.00	0.00	0.00	0.00	0.00	0.00	5.00	
MH 2 SWR 2 - 1	0.00	0.00	0.00	0.00	0.00	0.00	0.00	0.00	32.00	
MH 3 SWR 3 - 1	0.00	0.00	0.00	0.00	0.00	0.00	0.00	0.00	14.00	
MH 4 SWR 4 - 1	0.00	0.00	0.00	0.00	0.00	0.00	0.00	0.00	7.00	
MH 9 SWR 9 - 1	0.00	0.00	0.00	0.00	0.00	0.00	0.00	0.00	2.50	
MH 10 SWR 10 - 1	0.00	0.00	0.00	0.00	0.00	0.00	0.00	0.00	2.50	
MH 6 SWR 6 - 1	0.00	0.00	0.00	0.00	0.00	0.00	0.00	0.00	20.00	
MH 7 SWR 7 - 1	0.00	0.00	0.00	0.00	0.00	0.00	0.00	0.00	17.00	
MH 8 SWR 8 - 1	0.00	0.00	0.00	0.00	0.00	0.00	0.00	0.00	8.00	

## Sewer Input Summary:

Element Name	Sewer Length (ft)	Elevation			Loss Coefficients			Given Dimensions		
		Downstream Invert (ft)	Slope (%)	Upstream Invert (ft)	Mannings n	Bend Loss	Lateral Loss	Cross Section	Rise (ft or in)	Span (ft or in)
MH 1 SWR 1 - 1	166.16	7012.75	0.5	7013.58	0.013	0.03	1.00	CIRCULAR	30.00 in	30.00 in

MH 5 SWR 5 - 1	3.17	7014.58	1.0	7014.61	0.013	1.32	0.00	CIRCULAR	18.00 in	18.00 in
MH 2 SWR 2 - 1	256.17	7014.08	0.5	7015.36	0.013	0.05	1.00	CIRCULAR	30.00 in	30.00 in
MH 3 SWR 3 - 1	187.50	7015.87	7.6	7030.16	0.013	0.05	1.00	CIRCULAR	24.00 in	24.00 in
MH 4 SWR 4 - 1	145.36	7030.66	5.7	7038.92	0.013	0.05	1.00	CIRCULAR	18.00 in	18.00 in
MH 9 SWR 9 - 1	275.71	7039.42	5.4	7054.20	0.013	0.83	0.00	CIRCULAR	18.00 in	18.00 in
MH 10 SWR 10 - 1	7.53	7054.70	1.1	7054.78	0.013	0.38	1.00	CIRCULAR	18.00 in	18.00 in
MH 6 SWR 6 - 1	41.85	7015.86	11.4	7020.63	0.013	0.83	1.00	CIRCULAR	24.00 in	24.00 in
MH 7 SWR 7 - 1	69.88	7021.13	3.1	7023.28	0.013	0.94	1.00	CIRCULAR	24.00 in	24.00 in
MH 8 SWR 8 - 1	200.00	7023.78	4.5	7032.73	0.013	0.05	1.00	CIRCULAR	18.00 in	18.00 in

## Sewer Flow Summary:

**REVISED**

Unresolved:  
Per storm profiles in  
CD set, pipe size is 24".

Element Name	Full Flow Capacity		Critical Flow		Normal Flow				Flow (cfs)	Surcharged Length (ft)	Comment
	Flow (cfs)	Velocity (fps)	Depth (in)	Velocity (fps)	Depth (in)	Velocity (fps)	Froude Number	Flow Condition			
MH 1 SWR 1 - 1	29.08	5.92	30.00	7.33	30.00	7.33	0.00	Pressurized	36.00	166.16	
MH 5 SWR 5 - 1	10.53	5.96	10.32	4.77	8.73	5.88	1.38	Pressurized	5.00	3.17	
MH 2 SWR 2 - 1	29.08	5.92	30.00	6.52	30.00	6.52	0.00	Pressurized	32.00	256.17	

MH 3 SWR 3 - 1	62.62	19.93	16.17	6.22	7.71	16.06	4.14	Supercritical Jump	14.00	18.03	
MH 4 SWR 4 - 1	25.11	14.21	12.29	5.45	6.50	12.17	3.40	Supercritical	7.00	0.00	
MH 9 SWR 9 - 1	24.39	13.80	7.18	3.80	3.89	8.89	3.28	Supercritical	2.50	0.00	
MH 10 SWR 10 - 1	10.83	6.13	7.18	3.80	5.88	4.98	1.47	Supercritical	2.50	0.00	
MH 6 SWR 6 - 1	76.58	24.38	19.27	7.40	8.37	20.51	5.05	Supercritical Jump	20.00	11.11	Velocity is Too High
MH 7 SWR 7 - 1	39.79	12.66	17.83	6.79	10.96	12.17	2.56	Supercritical	17.00	0.00	
MH 8 SWR 8 - 1	22.28	12.61	13.15	5.78	7.46	11.57	2.98	Supercritical	8.00	0.00	

- A Froude number of 0 indicates that pressurized flow occurs (adverse slope or undersized pipe)
- If the sewer is not pressurized, full flow represents the maximum gravity flow in the sewer.
- If the sewer is pressurized, full flow represents the pressurized flow conditions.

Per ECM section 3.3.1.J.8 maximum storm sewer velocity is 18 fps. Please revise

REVISED

### Sewer Sizing Summary:

Element Name	Peak Flow (cfs)	Cross Section	Existing		Calculated		Used			Comment
			Rise	Span	Rise	Span	Rise	Span	Area (ft^2)	
MH 1 SWR 1 - 1	36.00	CIRCULAR	30.00 in	30.00 in	33.00 in	33.00 in	30.00 in	30.00 in	4.91	Existing height is smaller than the suggested height.

											Existing width is smaller than the suggested width. Exceeds max. Depth/Rise
MH 5 SWR 5 - 1	5.00	CIRCULAR	18.00 in	18.00 in	18.00 in	18.00 in	18.00 in	18.00 in	18.00 in	1.77	
MH 2 SWR 2 - 1	32.00	CIRCULAR	30.00 in	30.00 in	33.00 in	33.00 in	30.00 in	30.00 in	30.00 in	4.91	Existing height is smaller than the suggested height. Existing width is smaller than the suggested width. Exceeds max. Depth/Rise
MH 3 SWR 3 - 1	14.00	CIRCULAR	24.00 in	24.00 in	18.00 in	18.00 in	24.00 in	24.00 in	24.00 in	3.14	
MH 4 SWR 4 - 1	7.00	CIRCULAR	18.00 in	18.00 in	18.00 in	18.00 in	18.00 in	18.00 in	18.00 in	1.77	
MH 9 SWR 9 - 1	2.50	CIRCULAR	18.00 in	18.00 in	18.00 in	18.00 in	18.00 in	18.00 in	18.00 in	1.77	
MH 10 SWR 10 - 1	2.50	CIRCULAR	18.00 in	18.00 in	18.00 in	18.00 in	18.00 in	18.00 in	18.00 in	1.77	
MH 6 SWR 6 - 1	20.00	CIRCULAR	24.00 in	24.00 in	18.00 in	18.00 in	24.00 in	24.00 in	24.00 in	3.14	
MH 7 SWR 7 - 1	17.00	CIRCULAR	24.00 in	24.00 in	18.00 in	18.00 in	24.00 in	24.00 in	24.00 in	3.14	
MH 8 SWR 8 - 1	8.00	CIRCULAR	18.00 in	18.00 in	18.00 in	18.00 in	18.00 in	18.00 in	18.00 in	1.77	

- Calculated diameter was determined by sewer hydraulic capacity rounded up to the nearest commercially available size.
  - Sewer sizes should not decrease downstream.
  - All hydraulics were calculated using the 'Used' parameters.
-

## Grade Line Summary:

Tailwater Elevation (ft): 7013.75

Element Name	Invert Elev.		Downstream Manhole Losses		HGL		EGL		
	Downstream (ft)	Upstream (ft)	Bend Loss (ft)	Lateral Loss (ft)	Downstream (ft)	Upstream (ft)	Downstream (ft)	Friction Loss (ft)	Upstream (ft)
MH 1 SWR 1 - 1	7012.75	7013.58	0.00	0.00	7015.25	7016.52	7016.08	1.27	7017.36
MH 5 SWR 5 - 1	7014.58	7014.61	0.16	0.00	7017.40	7017.40	7017.52	0.01	7017.53
MH 2 SWR 2 - 1	7014.08	7015.36	0.03	0.18	7016.91	7018.46	7017.57	1.55	7019.12
MH 3 SWR 3 - 1	7015.87	7030.16	0.02	0.35	7019.18	7031.51	7019.48	12.62	7032.11
MH 4 SWR 4 - 1	7030.66	7038.92	0.01	0.06	7031.58	7039.94	7033.50	6.90	7040.40
MH 9 SWR 9 - 1	7039.42	7054.20	0.03	0.00	7039.97	7054.80	7040.97	14.05	7055.02
MH 10 SWR 10 - 1	7054.70	7054.78	0.01	0.00	7055.19	7055.38	7055.58	0.03	7055.60
MH 6 SWR 6 - 1	7015.86	7020.63	0.52	0.03	7019.04	7022.24	7019.67	3.42	7023.09
MH 7 SWR 7 - 1	7021.13	7023.28	0.43	0.17	7022.84	7024.77	7024.34	1.14	7025.48
MH 8 SWR 8 - 1	7023.78	7032.73	0.02	0.14	7024.92	7033.83	7026.48	7.87	7034.35

- Bend and Lateral losses only apply when there is an outgoing sewer. The system outfall, sewer #0, is not considered a sewer.
- Bend loss = Bend K \* V<sub>fi</sub> ^ 2 / (2 \* g)
- Lateral loss = V<sub>fo</sub> ^ 2 / (2 \* g) - Junction Loss K \* V<sub>fi</sub> ^ 2 / (2 \* g).
- Friction loss is always Upstream EGL - Downstream EGL.



## STORMWATER QUALITY CALCULATIONS



**Design Procedure Form: Extended Detention Basin (EDB)**

UD-BMP (Version 3.07, March 2018)

Sheet 1 of 3

**Designer:** Marc A. Whorton, P.E.  
**Company:** Classic Consulting  
**Date:** July 20, 2023  
**Project:** Monument Junction Development - Hwy. 105 & JCP Int. Imps.  
**Location:** SWQ Facility in CDOT ROW

<p>1. Basin Storage Volume</p> <p>A) Effective Imperviousness of Tributary Area, <math>I_a</math></p> <p>B) Tributary Area's Imperviousness Ratio (<math>i = I_a / 100</math>)</p> <p>C) Contributing Watershed Area</p> <p>D) For Watersheds Outside of the Denver Region, Depth of Average Runoff Producing Storm</p> <p>E) Design Concept (Select EURV when also designing for flood control)</p> <p>F) Design Volume (WQCV) Based on 40-hour Drain Time (<math>V_{DESIGN} = (1.0 * (0.91 * i^3 - 1.19 * i^2 + 0.78 * i) / 12 * Area)</math>)</p> <p>G) For Watersheds Outside of the Denver Region, Water Quality Capture Volume (WQCV) Design Volume (<math>V_{WQCV\ OTHER} = (d_6 * V_{DESIGN} / 0.43)</math>)</p> <p>H) User Input of Water Quality Capture Volume (WQCV) Design Volume (Only if a different WQCV Design Volume is desired)</p> <p>I) NRCS Hydrologic Soil Groups of Tributary Watershed              i) Percentage of Watershed consisting of Type A Soils              ii) Percentage of Watershed consisting of Type B Soils              iii) Percentage of Watershed consisting of Type C/D Soils</p> <p>J) Excess Urban Runoff Volume (EURV) Design Volume              For HSG A: <math>EURV_A = 1.68 * i^{1.28}</math>              For HSG B: <math>EURV_B = 1.36 * i^{1.08}</math>              For HSG C/D: <math>EURV_{C/D} = 1.20 * i^{1.08}</math></p> <p>K) User Input of Excess Urban Runoff Volume (EURV) Design Volume (Only if a different EURV Design Volume is desired)</p>	<p><math>I_a =</math> <input type="text" value="53.6"/> %</p> <p><math>i =</math> <input type="text" value="0.536"/></p> <p>Area = <input type="text" value="11.840"/> ac</p> <p><math>d_6 =</math> <input type="text" value="0.42"/> in</p> <div style="border: 1px solid black; padding: 5px; margin: 5px 0;"> <p>Choose One</p> <p><input checked="" type="radio"/> Water Quality Capture Volume (WQCV)</p> <p><input type="radio"/> Excess Urban Runoff Volume (EURV)</p> </div> <p><math>V_{DESIGN} =</math> <input type="text"/> ac-ft</p> <p><math>V_{DESIGN\ OTHER} =</math> <input type="text"/> ac-ft</p> <p><math>V_{DESIGN\ USER} =</math> <input type="text" value="0.121"/> ac-ft</p> <p>HSG <sub>A</sub> = <input type="text"/> %</p> <p>HSG <sub>B</sub> = <input type="text"/> %</p> <p>HSG <sub>C/D</sub> = <input type="text"/> %</p> <p><math>EURV_{DESIGN} =</math> <input type="text"/> ac-ft</p> <p><math>EURV_{DESIGN\ USER} =</math> <input type="text"/> ac-ft</p>
<p>2. Basin Shape: Length to Width Ratio (A basin length to width ratio of at least 2:1 will improve TSS reduction.)</p>	<p>L : W = <input type="text" value="2.0"/> : 1</p>
<p>3. Basin Side Slopes</p> <p>A) Basin Maximum Side Slopes (Horizontal distance per unit vertical, 4:1 or flatter preferred)</p>	<p>Z = <input type="text" value="3.00"/> ft / ft</p> <p align="center"><b>DIFFICULT TO MAINTAIN, INCREASE WHERE POSSIBLE</b></p>
<p>4. Inlet</p> <p>A) Describe means of providing energy dissipation at concentrated inflow locations:</p>	<p>Concrete Forebay</p> <hr/> <hr/> <hr/>
<p>5. Forebay</p> <p>A) Minimum Forebay Volume (<math>V_{FMIN} =</math> <input type="text" value="3%"/> of the WQCV)</p> <p>B) Actual Forebay Volume</p> <p>C) Forebay Depth (<math>D_F =</math> <input type="text" value="18"/> inch maximum)</p> <p>D) Forebay Discharge</p> <p>i) Undetained 100-year Peak Discharge</p> <p>ii) Forebay Discharge Design Flow (<math>Q_F = 0.02 * Q_{100}</math>)</p> <p>E) Forebay Discharge Design</p> <p>F) Discharge Pipe Size (minimum 8-inches)</p> <p>G) Rectangular Notch Width</p>	<p><math>V_{FMIN} =</math> <input type="text" value="0.004"/> ac-ft</p> <p><math>V_F =</math> <input type="text" value="0.004"/> ac-ft</p> <p><math>D_F =</math> <input type="text" value="18.0"/> in</p> <p><math>Q_{100} =</math> <input type="text" value="36.00"/> cfs</p> <p><math>Q_F =</math> <input type="text" value="0.72"/> cfs</p> <div style="border: 1px solid black; padding: 5px; margin: 5px 0;"> <p>Choose One</p> <p><input type="radio"/> Berm With Pipe</p> <p><input checked="" type="radio"/> Wall with Rect. Notch</p> <p><input type="radio"/> Wall with V-Notch Weir</p> </div> <p align="right" style="color: blue;">Flow too small for berm w/ pipe</p> <p>Calculated <math>D_P =</math> <input type="text"/> in</p> <p>Calculated <math>W_N =</math> <input type="text" value="5.0"/> in</p>

**Design Procedure Form: Extended Detention Basin (EDB)**

Sheet 2 of 3

**Designer:** Marc A. Whorton, P.E.  
**Company:** Classic Consulting  
**Date:** July 20, 2023  
**Project:** Monument Junction Development - Hwy. 105 & JCP Int. Imps.  
**Location:** SWQ Facility in CDOT ROW

<p>6. Trickle Channel</p> <p>A) Type of Trickle Channel</p> <p>F) Slope of Trickle Channel</p>	<div style="border: 1px solid black; padding: 5px; margin-bottom: 10px;">                 Choose One  <input type="radio"/> Concrete  <input checked="" type="radio"/> Soft Bottom             </div> <p style="color: blue; font-size: small;">PROVIDE A CONSISTENT LONGITUDINAL SLOPE FROM FOREBAY TO MICROPOOL WITH NO MEANDERING. RIPRAP AND SOIL RIPRAP LINED CHANNELS ARE NOT RECOMMENDED. MINIMUM DEPTH OF 1.5 FEET</p> <p>S = <input type="text" value="0.0200"/> ft / ft</p>
<p>7. Micropool and Outlet Structure</p> <p>A) Depth of Micropool (2.5-foot minimum)</p> <p>B) Surface Area of Micropool (10 ft<sup>2</sup> minimum)</p> <p>C) Outlet Type</p> <p>D) Smallest Dimension of Orifice Opening Based on Hydrograph Routing (Use UD-Detention)</p> <p>E) Total Outlet Area</p>	<p>D<sub>M</sub> = <input type="text" value="2.5"/> ft</p> <p>A<sub>M</sub> = <input type="text" value="48"/> sq ft</p> <div style="border: 1px solid black; padding: 5px; margin-bottom: 10px;">                 Choose One  <input checked="" type="radio"/> Orifice Plate  <input type="radio"/> Other (Describe):                  _____                  _____             </div> <p>D<sub>orifice</sub> = <input type="text" value="1.19"/> inches</p> <p>A<sub>orifice</sub> = <input type="text" value="4.36"/> square inches</p>
<p>8. Initial Surcharge Volume</p> <p>A) Depth of Initial Surcharge Volume (Minimum recommended depth is 4 inches)</p> <p>B) Minimum Initial Surcharge Volume (Minimum volume of 0.3% of the WQCV)</p> <p>C) Initial Surcharge Provided Above Micropool</p>	<p>D<sub>IS</sub> = <input type="text" value="6"/> in</p> <p>V<sub>IS</sub> = <input type="text" value="16"/> cu ft</p> <p>V<sub>s</sub> = <input type="text" value="24.0"/> cu ft</p>
<p>9. Trash Rack</p> <p>A) Water Quality Screen Open Area: <math>A_t = A_{ot} * 38.5 * (e^{-0.095D})</math></p> <p>B) Type of Screen (If specifying an alternative to the materials recommended in the USDCM, indicate "other" and enter the ratio of the total open area to the total screen area for the material specified.)</p> <p style="text-align: center;">Other (Y/N): <input type="text" value="N"/></p> <p>C) Ratio of Total Open Area to Total Area (only for type 'Other')</p> <p>D) Total Water Quality Screen Area (based on screen type)</p> <p>E) Depth of Design Volume (EURV or WQCV) (Based on design concept chosen under 1E)</p> <p>F) Height of Water Quality Screen (H<sub>TR</sub>)</p> <p>G) Width of Water Quality Screen Opening (W<sub>opening</sub>) (Minimum of 12 inches is recommended)</p>	<p>A<sub>t</sub> = <input type="text" value="150"/> square inches</p> <div style="border: 1px solid black; padding: 2px; margin-bottom: 10px; text-align: center; font-size: small;">S.S. Well Screen with 60% Open Area</div> <p>User Ratio = <input type="text"/></p> <p>A<sub>total</sub> = <input type="text" value="250"/> sq. in.</p> <p>H = <input type="text" value="5.5"/> feet</p> <p>H<sub>TR</sub> = <input type="text" value="94"/> inches</p> <p>W<sub>opening</sub> = <input type="text" value="12.0"/> inches</p> <p style="color: red; font-size: small;">VALUE LESS THAN RECOMMENDED MIN. WIDTH. WIDTH HAS BEEN SET TO 12 INCHES.</p>

**Design Procedure Form: Extended Detention Basin (EDB)**

Sheet 3 of 3

**Designer:** Marc A. Whorton, P.E.  
**Company:** Classic Consulting  
**Date:** July 20, 2023  
**Project:** Monument Junction Development - Hwy. 105 & JCP Int. Imps.  
**Location:** SWQ Facility in CDOT ROW

<p>10. Overflow Embankment</p> <p>A) Describe embankment protection for 100-year and greater overtopping:</p> <p>B) Slope of Overflow Embankment (Horizontal distance per unit vertical, 4:1 or flatter preferred)</p>	<p>Buried Rip-Rap</p> <hr/> <hr/> <p>Ze = <input style="width: 50px;" type="text" value="50.00"/> ft / ft</p>
<p>11. Vegetation</p>	<div style="border: 1px solid black; padding: 5px;"> <p>Choose One</p> <p><input type="radio"/> Irrigated</p> <p><input checked="" type="radio"/> Not Irrigated</p> </div>
<p>12. Access</p> <p>A) Describe Sediment Removal Procedures</p>	<hr/> <hr/> <hr/> <hr/> <hr/>
<p>Notes: _____</p> <hr/> <hr/> <hr/>	

**Design Procedure Form: Extended Detention Basin (EDB)**

UD-BMP (Version 3.07, March 2018)

Sheet 1 of 3

**Designer:** Marc A. Whorton, P.E.  
**Company:** Classic Consulting  
**Date:** July 20, 2023  
**Project:** Monument Junction Development - Hwy. 105 & JCP Int. Imps.  
**Location:** SWQ Facility - Forebay Sizing

<p>1. Basin Storage Volume</p> <p>A) Effective Imperviousness of Tributary Area, <math>I_a</math></p> <p>B) Tributary Area's Imperviousness Ratio (<math>i = I_a / 100</math>)</p> <p>C) Contributing Watershed Area</p> <p>D) For Watersheds Outside of the Denver Region, Depth of Average Runoff Producing Storm</p> <p>E) Design Concept (Select EURV when also designing for flood control)</p> <p>F) Design Volume (WQCV) Based on 40-hour Drain Time (<math>V_{DESIGN} = (1.0 * (0.91 * i^3 - 1.19 * i^2 + 0.78 * i) / 12 * Area)</math>)</p> <p>G) For Watersheds Outside of the Denver Region, Water Quality Capture Volume (WQCV) Design Volume (<math>V_{WQCV\ OTHER} = (d_s * V_{DESIGN} / 0.43)</math>)</p> <p>H) User Input of Water Quality Capture Volume (WQCV) Design Volume (Only if a different WQCV Design Volume is desired)</p> <p>I) NRCS Hydrologic Soil Groups of Tributary Watershed              i) Percentage of Watershed consisting of Type A Soils              ii) Percentage of Watershed consisting of Type B Soils              iii) Percentage of Watershed consisting of Type C/D Soils</p> <p>J) Excess Urban Runoff Volume (EURV) Design Volume              For HSG A: <math>EURV_A = 1.68 * i^{1.28}</math>              For HSG B: <math>EURV_B = 1.36 * i^{1.08}</math>              For HSG C/D: <math>EURV_{C/D} = 1.20 * i^{1.08}</math></p> <p>K) User Input of Excess Urban Runoff Volume (EURV) Design Volume (Only if a different EURV Design Volume is desired)</p>	<p><math>I_a =</math> <input type="text" value="67.2"/> %</p> <p><math>i =</math> <input type="text" value="0.672"/></p> <p>Area = <input type="text" value="8.490"/> ac</p> <p><math>d_s =</math> <input type="text" value="0.42"/> in</p> <div style="border: 1px solid black; padding: 5px; margin: 5px 0;"> <p>Choose One</p> <p><input checked="" type="radio"/> Water Quality Capture Volume (WQCV)</p> <p><input type="radio"/> Excess Urban Runoff Volume (EURV)</p> </div> <p><math>V_{DESIGN} =</math> <input type="text"/> ac-ft</p> <p><math>V_{DESIGN\ OTHER} =</math> <input type="text"/> ac-ft</p> <p><math>V_{DESIGN\ USER} =</math> <input type="text" value="0.121"/> ac-ft</p> <p>HSG <sub>A</sub> = <input type="text"/> %              HSG <sub>B</sub> = <input type="text"/> %              HSG <sub>C/D</sub> = <input type="text"/> %</p> <p><math>EURV_{DESIGN} =</math> <input type="text"/> ac-ft</p> <p><math>EURV_{DESIGN\ USER} =</math> <input type="text"/> ac-ft</p>
<p>2. Basin Shape: Length to Width Ratio (A basin length to width ratio of at least 2:1 will improve TSS reduction.)</p>	<p>L : W = <input type="text" value="2.0"/> : 1</p>
<p>3. Basin Side Slopes</p> <p>A) Basin Maximum Side Slopes (Horizontal distance per unit vertical, 4:1 or flatter preferred)</p>	<p>Z = <input type="text" value="3.00"/> ft / ft  <span style="color: red; font-weight: bold;">DIFFICULT TO MAINTAIN, INCREASE WHERE POSSIBLE</span></p>
<p>4. Inlet</p> <p>A) Describe means of providing energy dissipation at concentrated inflow locations:</p>	<p>Concrete Forebay</p> <hr/> <hr/> <hr/>
<p>5. Forebay</p> <p>A) Minimum Forebay Volume (<math>V_{FMIN} =</math> <input type="text" value="3%"/> of the WQCV)</p> <p>B) Actual Forebay Volume</p> <p>C) Forebay Depth (<math>D_F =</math> <input type="text" value="18"/> inch maximum)</p> <p>D) Forebay Discharge</p> <p>i) Undetained 100-year Peak Discharge</p> <p>ii) Forebay Discharge Design Flow (<math>Q_F = 0.02 * Q_{100}</math>)</p> <p>E) Forebay Discharge Design</p> <p>F) Discharge Pipe Size (minimum 8-inches)</p> <p>G) Rectangular Notch Width</p>	<p><math>V_{FMIN} =</math> <input type="text" value="0.004"/> ac-ft</p> <p><math>V_F =</math> <input type="text" value="0.004"/> ac-ft</p> <p><math>D_F =</math> <input type="text" value="18.0"/> in</p> <p><math>Q_{100} =</math> <input type="text" value="36.00"/> cfs</p> <p><math>Q_F =</math> <input type="text" value="0.72"/> cfs</p> <div style="border: 1px solid black; padding: 5px; margin: 5px 0;"> <p>Choose One</p> <p><input type="radio"/> Berm With Pipe</p> <p><input checked="" type="radio"/> Wall with Rect. Notch</p> <p><input type="radio"/> Wall with V-Notch Weir</p> </div> <p style="color: blue; font-weight: bold;">Flow too small for berm w/ pipe</p> <p>Calculated <math>D_P =</math> <input type="text"/> in</p> <p>Calculated <math>W_N =</math> <input type="text" value="5.0"/> in</p>

**Design Procedure Form: Extended Detention Basin (EDB)**

**Designer:** Marc A. Whorton, P.E.  
**Company:** Classic Consulting  
**Date:** July 20, 2023  
**Project:** Monument Junction Development - Hwy. 105 & JCP Int. Imps.  
**Location:** SWQ Facility - Forebay Sizing

<p>6. Trickle Channel</p> <p>A) Type of Trickle Channel</p> <p>F) Slope of Trickle Channel</p>	<div style="border: 1px solid black; padding: 5px; margin-bottom: 10px;">             Choose One  <input type="radio"/> Concrete  <input checked="" type="radio"/> Soft Bottom         </div> <p>S = <input type="text" value="0.0200"/> ft / ft</p> <p style="color: blue; font-size: small;">PROVIDE A CONSISTENT LONGITUDINAL SLOPE FROM FOREBAY TO MICROPOOL WITH NO MEANDERING. RIPRAP AND SOIL RIPRAP LINED CHANNELS ARE NOT RECOMMENDED. MINIMUM DEPTH OF 1.5 FEET</p>
<p>7. Micropool and Outlet Structure</p> <p>A) Depth of Micropool (2.5-foot minimum)</p> <p>B) Surface Area of Micropool (10 ft<sup>2</sup> minimum)</p> <p>C) Outlet Type</p> <p>D) Smallest Dimension of Orifice Opening Based on Hydrograph Routing (Use UD-Detention)</p> <p>E) Total Outlet Area</p>	<p>D<sub>M</sub> = <input type="text"/> ft</p> <p>A<sub>M</sub> = <input type="text"/> sq ft</p> <div style="border: 1px solid black; padding: 5px; margin-bottom: 10px;">             Choose One  <input checked="" type="radio"/> Orifice Plate  <input type="radio"/> Other (Describe):              _____              _____         </div> <p>D<sub>orifice</sub> = <input type="text"/> inches</p> <p>A<sub>orifice</sub> = <input type="text"/> square inches</p>
<p>8. Initial Surcharge Volume</p> <p>A) Depth of Initial Surcharge Volume (Minimum recommended depth is 4 inches)</p> <p>B) Minimum Initial Surcharge Volume (Minimum volume of 0.3% of the WQCV)</p> <p>C) Initial Surcharge Provided Above Micropool</p>	<p>D<sub>IS</sub> = <input type="text"/> in</p> <p>V<sub>IS</sub> = <input type="text" value="16"/> cu ft</p> <p>V<sub>s</sub> = <input type="text"/> cu ft</p>
<p>9. Trash Rack</p> <p>A) Water Quality Screen Open Area: <math>A_t = A_{ot} * 38.5 * (e^{-0.095D})</math></p> <p>B) Type of Screen (If specifying an alternative to the materials recommended in the USDCM, indicate "other" and enter the ratio of the total open are to the total screen are for the material specified.)</p> <p style="text-align: center;">Other (Y/N): <input type="text"/></p> <p>C) Ratio of Total Open Area to Total Area (only for type 'Other')</p> <p>D) Total Water Quality Screen Area (based on screen type)</p> <p>E) Depth of Design Volume (EURV or WQCV) (Based on design concept chosen under 1E)</p> <p>F) Height of Water Quality Screen (H<sub>TR</sub>)</p> <p>G) Width of Water Quality Screen Opening (W<sub>opening</sub>) (Minimum of 12 inches is recommended)</p>	<p>A<sub>t</sub> = <input type="text"/> square inches</p> <p><input type="text"/></p> <p>_____</p> <p>_____</p> <p>User Ratio = <input type="text"/></p> <p>A<sub>total</sub> = <input type="text"/> sq. in.</p> <p>H = <input type="text"/> feet</p> <p>H<sub>TR</sub> = <input type="text"/> inches</p> <p>W<sub>opening</sub> = <input type="text"/> inches</p>

**Design Procedure Form: Extended Detention Basin (EDB)**

Sheet 3 of 3

**Designer:** Marc A. Whorton, P.E.  
**Company:** Classic Consulting  
**Date:** July 20, 2023  
**Project:** Monument Junction Development - Hwy. 105 & JCP Int. Imps.  
**Location:** SWQ Facility - Forebay Sizing

<p>10. Overflow Embankment</p> <p>A) Describe embankment protection for 100-year and greater overtopping:</p> <p>B) Slope of Overflow Embankment (Horizontal distance per unit vertical, 4:1 or flatter preferred)</p>	<p>Buried Rip-Rap</p> <hr/> <hr/> <p>Ze = <span style="border: 1px solid black; padding: 2px;">4.00</span> ft / ft</p>
<p>11. Vegetation</p>	<div style="border: 1px solid black; padding: 5px;"> <p>Choose One</p> <p><input type="radio"/> Irrigated</p> <p><input checked="" type="radio"/> Not Irrigated</p> </div>
<p>12. Access</p> <p>A) Describe Sediment Removal Procedures</p>	<hr/> <hr/> <hr/> <hr/> <hr/>
<p>Notes: _____</p> <hr/> <hr/> <hr/>	

**DETENTION FACILITY CALCULATIONS**







# DETENTION BASIN STAGE-STORAGE TABLE BUILDER

*MHFD-Detention, Version 4.05 (January 2022)*

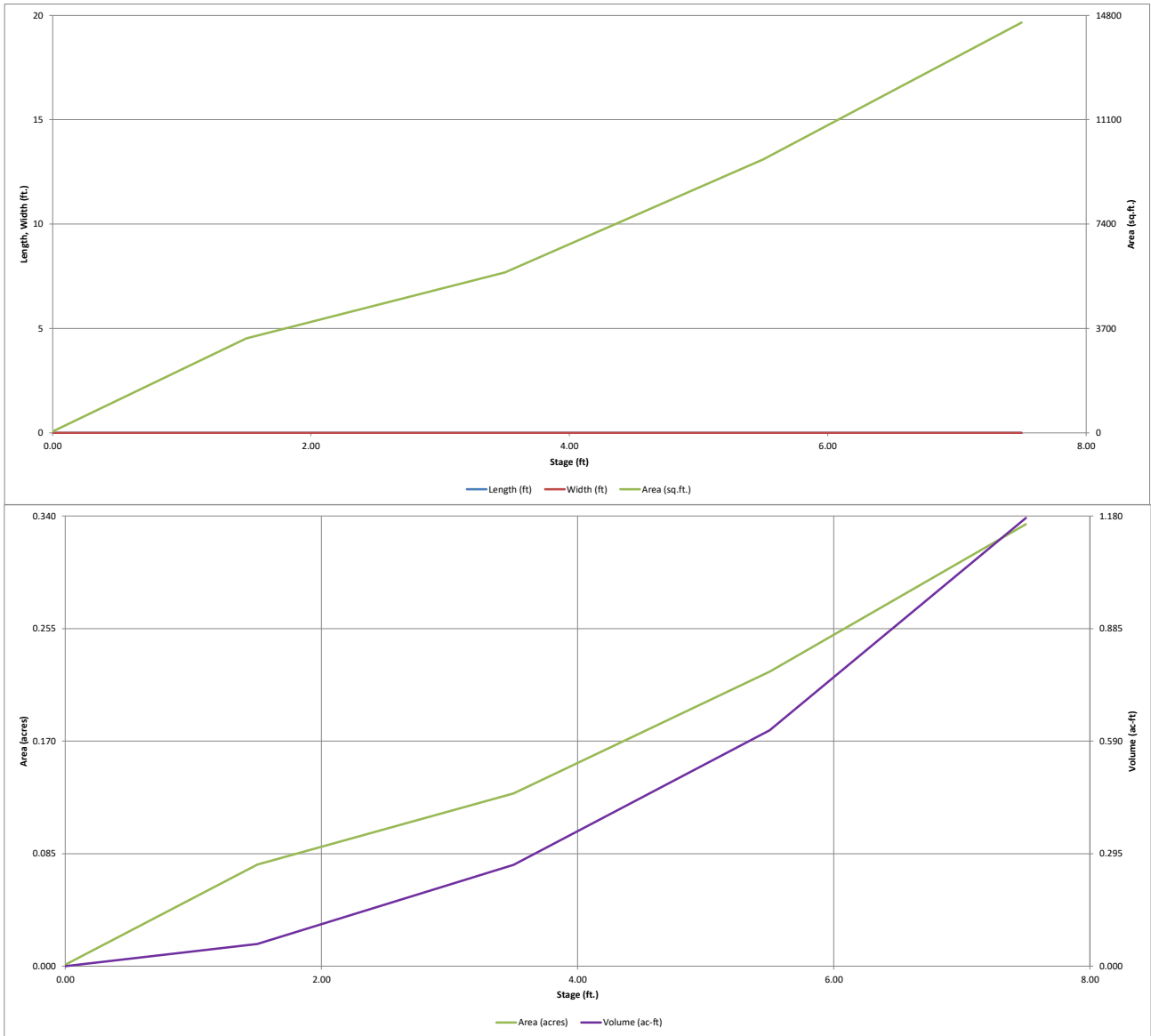

# DETENTION BASIN OUTLET STRUCTURE DESIGN

*MHFD-Detention, Version 4.05 (January 2022)*

**Project: Monument Junction Development - Hwy. 105 & JCP Int. Imps.**

**Basin ID: SWQ Facility in CDOT ROW**

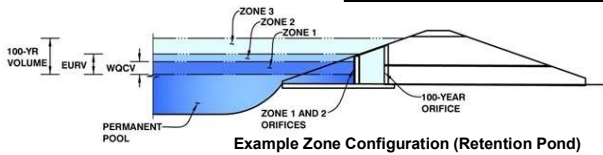

	Estimated Stage (ft)	Estimated Volume (ac-ft)	Outlet Type
Zone 1 (WQCV)	3.09	0.213	Orifice Plate
Zone 2 (EURV)	5.44	0.390	Orifice Plate
Zone 3 (100-year)	7.35	0.520	Weir&Pipe (Restrict)
<b>Total (all zones)</b>		<b>1.124</b>	

**User Input: Orifice at Underdrain Outlet (typically used to drain WQCV in a Filtration BMP)**

Underdrain Orifice Invert Depth =	N/A	ft (distance below the filtration media surface)
Underdrain Orifice Diameter =	N/A	inches

**Calculated Parameters for Underdrain**

Underdrain Orifice Area =	N/A	ft <sup>2</sup>
Underdrain Orifice Centroid =	N/A	feet

**User Input: Orifice Plate with one or more orifices or Elliptical Slot Weir (typically used to drain WQCV and/or EURV in a sedimentation BMP)**

Centroid of Lowest Orifice =	0.00	ft (relative to basin bottom at Stage = 0 ft)
Depth at top of Zone using Orifice Plate =	5.50	ft (relative to basin bottom at Stage = 0 ft)
Orifice Plate: Orifice Vertical Spacing =	16.50	inches
Orifice Plate: Orifice Area per Row =	1.09	sq. inches (diameter = 1-3/16 inches)

**Calculated Parameters for Plate**

WQ Orifice Area per Row =	7.569E-03	ft <sup>2</sup>
Elliptical Half-Width =	N/A	feet
Elliptical Slot Centroid =	N/A	feet
Elliptical Slot Area =	N/A	ft <sup>2</sup>

**User Input: Stage and Total Area of Each Orifice Row (numbered from lowest to highest)**

	Row 1 (required)	Row 2 (optional)	Row 3 (optional)	Row 4 (optional)	Row 5 (optional)	Row 6 (optional)	Row 7 (optional)	Row 8 (optional)
Stage of Orifice Centroid (ft)	0.00	1.40	2.80	4.20				
Orifice Area (sq. inches)	1.09	1.09	1.09	1.09				

	Row 9 (optional)	Row 10 (optional)	Row 11 (optional)	Row 12 (optional)	Row 13 (optional)	Row 14 (optional)	Row 15 (optional)	Row 16 (optional)
Stage of Orifice Centroid (ft)								
Orifice Area (sq. inches)								

**User Input: Vertical Orifice (Circular or Rectangular)**

	Not Selected	Not Selected	
Invert of Vertical Orifice =	N/A	N/A	ft (relative to basin bottom at Stage = 0 ft)
Depth at top of Zone using Vertical Orifice =	N/A	N/A	ft (relative to basin bottom at Stage = 0 ft)
Vertical Orifice Diameter =	N/A	N/A	inches

**Calculated Parameters for Vertical Orifice**

	Not Selected	Not Selected	
Vertical Orifice Area =	N/A	N/A	ft <sup>2</sup>
Vertical Orifice Centroid =	N/A	N/A	feet

**User Input: Overflow Weir (Dropbox with Flat or Sloped Grate and Outlet Pipe OR Rectangular/Trapezoidal Weir and No Outlet Pipe)**

	Zone 3 Weir	Not Selected	
Overflow Weir Front Edge Height, Ho =	5.50	N/A	ft (relative to basin bottom at Stage = 0 ft)
Overflow Weir Front Edge Length =	6.00	N/A	feet
Overflow Weir Grate Slope =	0.00	N/A	H:V
Horiz. Length of Weir Sides =	3.00	N/A	feet
Overflow Grate Type =	Type C Grate	N/A	
Debris Clogging % =	50%	N/A	%

**Calculated Parameters for Overflow Weir**

	Zone 3 Weir	Not Selected	
Height of Grate Upper Edge, H <sub>u</sub> =	5.50	N/A	feet
Overflow Weir Slope Length =	3.00	N/A	feet
Grate Open Area / 100-yr Orifice Area =	1.77	N/A	
Overflow Grate Open Area w/o Debris =	12.53	N/A	ft <sup>2</sup>
Overflow Grate Open Area w/ Debris =	6.26	N/A	ft <sup>2</sup>

**User Input: Outlet Pipe w/ Flow Restriction Plate (Circular Orifice, Restrictor Plate, or Rectangular Orifice)**

	Zone 3 Restrictor	Not Selected	
Depth to Invert of Outlet Pipe =	0.70	N/A	ft (distance below basin bottom at Stage = 0 ft)
Outlet Pipe Diameter =	36.00	N/A	inches
Restrictor Plate Height Above Pipe Invert =	36.00		inches

**Calculated Parameters for Outlet Pipe w/ Flow Restriction Plate**

	Zone 3 Restrictor	Not Selected	
Outlet Orifice Area =	7.07	N/A	ft <sup>2</sup>
Outlet Orifice Centroid =	1.50	N/A	feet
Half-Central Angle of Restrictor Plate on Pipe =	3.14	N/A	radians

**User Input: Emergency Spillway (Rectangular or Trapezoidal)**

Spillway Invert Stage =	6.50	ft (relative to basin bottom at Stage = 0 ft)
Spillway Crest Length =	30.00	feet
Spillway End Slopes =	3.00	H:V
Freeboard above Max Water Surface =	1.00	feet

**Calculated Parameters for Spillway**

Spillway Design Flow Depth =	0.51	feet
Stage at Top of Freeboard =	8.01	feet
Basin Area at Top of Freeboard =	0.33	acres
Basin Volume at Top of Freeboard =	1.18	acre-ft

**Routed Hydrograph Results**

*The user can override the default CUHP hydrographs and runoff volumes by entering new values in the Inflow Hydrographs table (Columns W through AF).*

	WQCV	EURV	2 Year	5 Year	10 Year	25 Year	50 Year	100 Year	500 Year
Design Storm Return Period =	N/A	N/A	1.19	1.50	1.75	2.00	2.25	2.52	3.85
One-Hour Rainfall Depth (in) =	N/A	N/A	1.19	1.50	1.75	2.00	2.25	2.52	3.85
CUHP Runoff Volume (acre-ft) =	0.213	0.604	0.673	0.955	1.195	1.472	1.723	2.026	3.392
Inflow Hydrograph Volume (acre-ft) =	N/A	N/A	0.673	0.955	1.195	1.472	1.723	2.026	3.392
CUHP Predevelopment Peak Q (cfs) =	N/A	N/A	2.6	5.4	7.5	11.5	14.2	17.5	31.7
OPTIONAL Override Predevelopment Peak Q (cfs) =	N/A	N/A	10.0	14.0	20.0	27.0	30.0	36.0	
Predevelopment Unit Peak Flow, q (cfs/acre) =	N/A	N/A	0.84	1.18	1.69	2.28	2.53	3.04	2.68
Peak Inflow Q (cfs) =	N/A	N/A	11.9	16.8	20.2	25.4	29.7	35.1	57.6
Peak Outflow Q (cfs) =	0.1	0.3	0.5	4.6	7.8	14.8	19.2	25.2	51.2
Ratio Peak Outflow to Predevelopment Q =	N/A	N/A	N/A	0.3	0.4	0.5	0.6	0.7	1.6
Structure Controlling Flow =	Plate	Plate	Overflow Weir 1	Overflow Weir 1	Overflow Weir 1	Overflow Weir 1	Overflow Weir 1	Overflow Weir 1	Spillway
Max Velocity through Grate 1 (fps) =	N/A	N/A	0.02	0.3	0.6	1.2	1.5	2.0	2.9
Max Velocity through Grate 2 (fps) =	N/A	N/A	N/A	N/A	N/A	N/A	N/A	N/A	N/A
Time to Drain 97% of Inflow Volume (hours) =	38	58	61	58	56	53	51	49	42
Time to Drain 99% of Inflow Volume (hours) =	40	63	66	65	64	63	62	61	56
Maximum Ponding Depth (ft) =	3.08	5.44	5.54	5.78	5.91	6.13	6.25	6.40	6.79
Area at Maximum Ponding Depth (acres) =	0.12	0.22	0.22	0.24	0.24	0.26	0.26	0.27	0.29
Maximum Volume Stored (acre-ft) =	0.213	0.606	0.626	0.683	0.712	0.768	0.801	0.842	0.949

# DETENTION BASIN OUTLET STRUCTURE DESIGN

*MHFD-Detention, Version 4.05 (January 2022)*

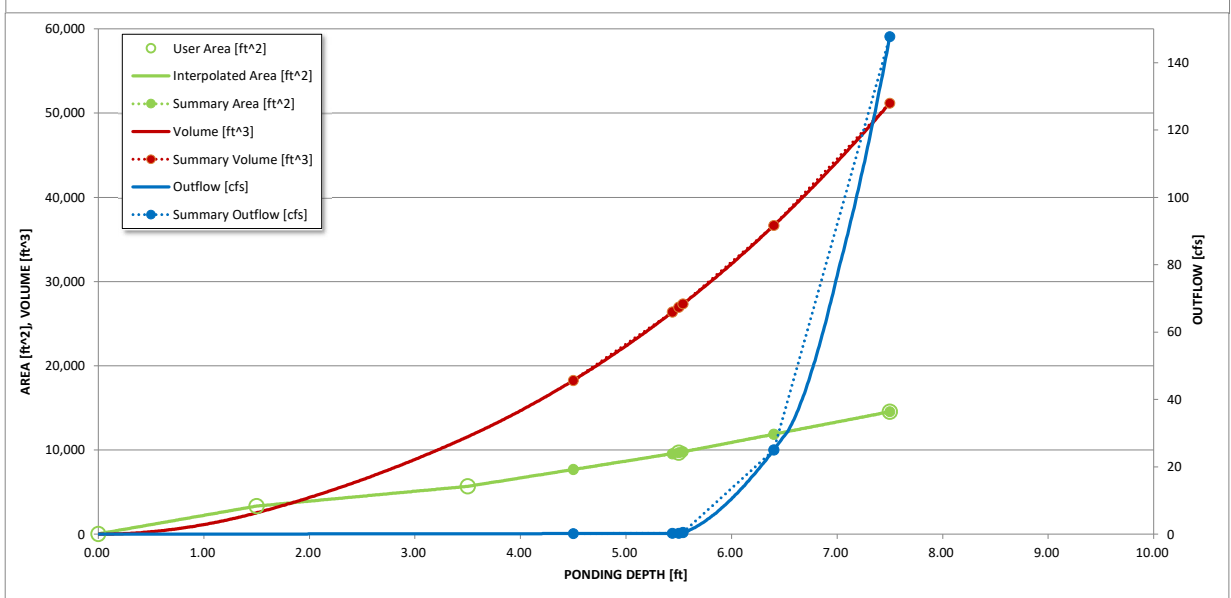
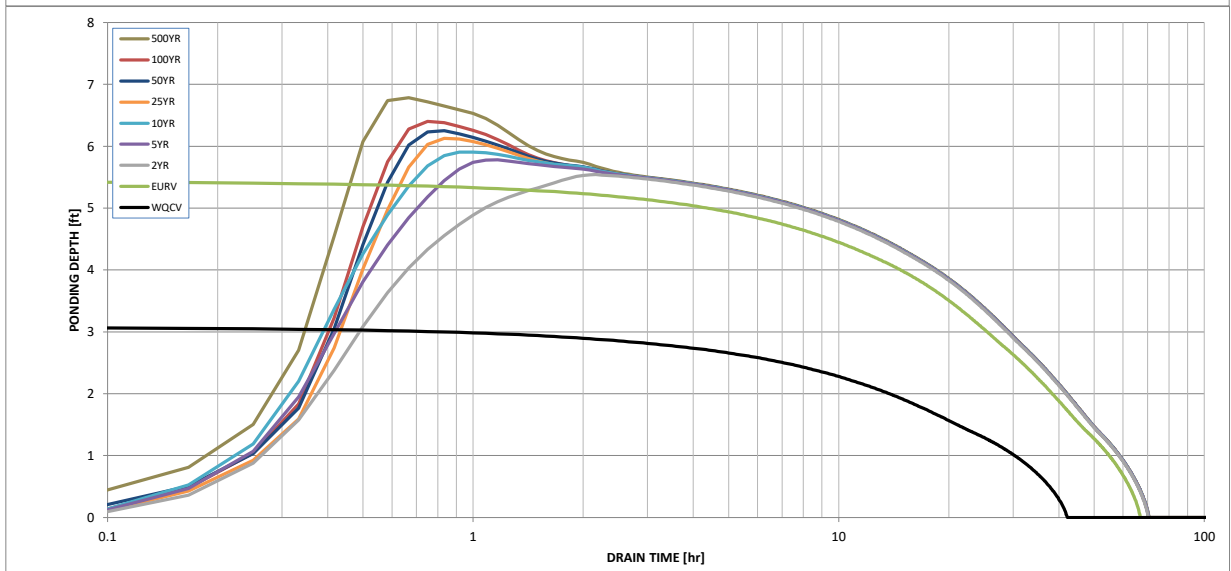
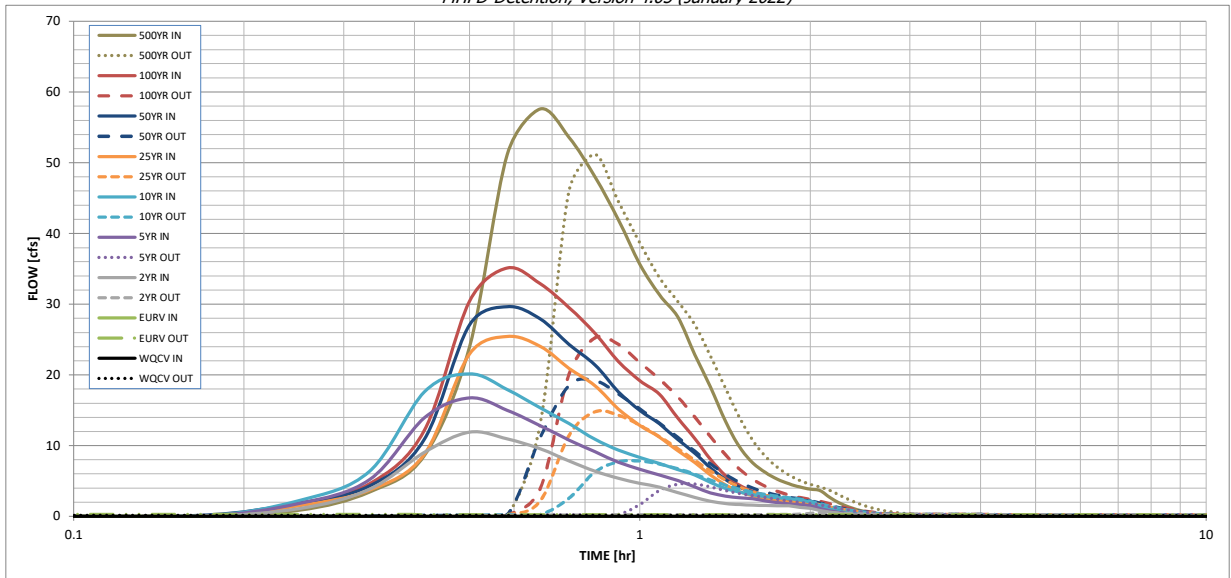

S-A-V-D Chart Axis Override	X-axis	Left Y-Axis	Right Y-Axis
minimum bound			
maximum bound			

# DETENTION BASIN OUTLET STRUCTURE DESIGN

*Outflow Hydrograph Workbook Filename:* \_\_\_\_\_

## Inflow Hydrographs

The user can override the calculated inflow hydrographs from this workbook with inflow hydrographs developed in a separate program.

Time Interval	SOURCE	CUHP	CUHP	CUHP	CUHP	CUHP	CUHP	CUHP	CUHP	CUHP
	TIME	WQCV [cfs]	EURV [cfs]	2 Year [cfs]	5 Year [cfs]	10 Year [cfs]	25 Year [cfs]	50 Year [cfs]	100 Year [cfs]	500 Year [cfs]
5.00 min	0:00:00	0.00	0.00	0.00	0.00	0.00	0.00	0.00	0.00	0.00
	0:05:00	0.00	0.00	0.00	0.00	0.00	0.00	0.00	0.00	0.00
	0:10:00	0.00	0.00	0.00	0.00	0.00	0.00	0.13	0.01	0.85
	0:15:00	0.00	0.00	1.11	1.81	2.23	1.50	1.86	1.83	3.46
	0:20:00	0.00	0.00	3.84	5.19	6.38	3.70	4.30	4.62	8.62
	0:25:00	0.00	0.00	9.05	13.93	17.60	8.81	10.91	12.17	23.92
	0:30:00	0.00	0.00	11.92	16.76	20.16	22.94	27.05	30.39	51.17
	0:35:00	0.00	0.00	10.94	15.00	17.92	25.45	29.66	35.13	57.60
	0:40:00	0.00	0.00	9.56	12.83	15.35	24.05	27.92	32.89	53.60
	0:45:00	0.00	0.00	7.81	10.80	13.12	20.93	24.30	29.53	48.00
	0:50:00	0.00	0.00	6.41	9.13	10.90	18.49	21.42	25.87	41.94
	0:55:00	0.00	0.00	5.38	7.67	9.37	15.18	17.62	21.91	35.64
	1:00:00	0.00	0.00	4.69	6.67	8.35	12.86	14.96	19.17	31.30
	1:05:00	0.00	0.00	4.13	5.84	7.48	11.21	13.06	17.26	28.20
	1:10:00	0.00	0.00	3.36	5.07	6.62	9.29	10.87	13.89	22.87
	1:15:00	0.00	0.00	2.68	4.16	5.84	7.61	8.94	11.01	18.28
	1:20:00	0.00	0.00	2.13	3.32	4.80	5.85	6.85	8.06	13.45
	1:25:00	0.00	0.00	1.81	2.87	3.97	4.46	5.23	5.78	9.81
	1:30:00	0.00	0.00	1.67	2.64	3.44	3.51	4.13	4.39	7.57
	1:35:00	0.00	0.00	1.59	2.48	3.07	2.90	3.42	3.54	6.19
	1:40:00	0.00	0.00	1.54	2.17	2.80	2.51	2.95	2.97	5.24
	1:45:00	0.00	0.00	1.51	1.94	2.62	2.24	2.63	2.58	4.60
	1:50:00	0.00	0.00	1.48	1.77	2.49	2.06	2.42	2.31	4.15
	1:55:00	0.00	0.00	1.28	1.65	2.31	1.94	2.27	2.12	3.83
	2:00:00	0.00	0.00	1.13	1.50	2.04	1.85	2.17	2.01	3.65
	2:05:00	0.00	0.00	0.83	1.10	1.48	1.36	1.59	1.47	2.67
	2:10:00	0.00	0.00	0.60	0.79	1.05	0.97	1.13	1.05	1.91
	2:15:00	0.00	0.00	0.43	0.56	0.75	0.69	0.81	0.76	1.37
	2:20:00	0.00	0.00	0.30	0.39	0.52	0.49	0.57	0.54	0.97
	2:25:00	0.00	0.00	0.21	0.26	0.36	0.33	0.39	0.37	0.67
	2:30:00	0.00	0.00	0.14	0.17	0.24	0.23	0.27	0.26	0.46
	2:35:00	0.00	0.00	0.08	0.11	0.16	0.15	0.18	0.17	0.30
	2:40:00	0.00	0.00	0.05	0.07	0.09	0.09	0.11	0.10	0.18
	2:45:00	0.00	0.00	0.02	0.03	0.04	0.04	0.05	0.05	0.09
	2:50:00	0.00	0.00	0.01	0.01	0.01	0.01	0.02	0.02	0.03
	2:55:00	0.00	0.00	0.00	0.00	0.00	0.00	0.00	0.00	0.00
	3:00:00	0.00	0.00	0.00	0.00	0.00	0.00	0.00	0.00	0.00
	3:05:00	0.00	0.00	0.00	0.00	0.00	0.00	0.00	0.00	0.00
	3:10:00	0.00	0.00	0.00	0.00	0.00	0.00	0.00	0.00	0.00
	3:15:00	0.00	0.00	0.00	0.00	0.00	0.00	0.00	0.00	0.00
	3:20:00	0.00	0.00	0.00	0.00	0.00	0.00	0.00	0.00	0.00
	3:25:00	0.00	0.00	0.00	0.00	0.00	0.00	0.00	0.00	0.00
	3:30:00	0.00	0.00	0.00	0.00	0.00	0.00	0.00	0.00	0.00
	3:35:00	0.00	0.00	0.00	0.00	0.00	0.00	0.00	0.00	0.00
	3:40:00	0.00	0.00	0.00	0.00	0.00	0.00	0.00	0.00	0.00
	3:45:00	0.00	0.00	0.00	0.00	0.00	0.00	0.00	0.00	0.00
	3:50:00	0.00	0.00	0.00	0.00	0.00	0.00	0.00	0.00	0.00
	3:55:00	0.00	0.00	0.00	0.00	0.00	0.00	0.00	0.00	0.00
	4:00:00	0.00	0.00	0.00	0.00	0.00	0.00	0.00	0.00	0.00
	4:05:00	0.00	0.00	0.00	0.00	0.00	0.00	0.00	0.00	0.00
	4:10:00	0.00	0.00	0.00	0.00	0.00	0.00	0.00	0.00	0.00
	4:15:00	0.00	0.00	0.00	0.00	0.00	0.00	0.00	0.00	0.00
	4:20:00	0.00	0.00	0.00	0.00	0.00	0.00	0.00	0.00	0.00
	4:25:00	0.00	0.00	0.00	0.00	0.00	0.00	0.00	0.00	0.00
	4:30:00	0.00	0.00	0.00	0.00	0.00	0.00	0.00	0.00	0.00
	4:35:00	0.00	0.00	0.00	0.00	0.00	0.00	0.00	0.00	0.00
	4:40:00	0.00	0.00	0.00	0.00	0.00	0.00	0.00	0.00	0.00
	4:45:00	0.00	0.00	0.00	0.00	0.00	0.00	0.00	0.00	0.00
	4:50:00	0.00	0.00	0.00	0.00	0.00	0.00	0.00	0.00	0.00
	4:55:00	0.00	0.00	0.00	0.00	0.00	0.00	0.00	0.00	0.00
	5:00:00	0.00	0.00	0.00	0.00	0.00	0.00	0.00	0.00	0.00
	5:05:00	0.00	0.00	0.00	0.00	0.00	0.00	0.00	0.00	0.00
	5:10:00	0.00	0.00	0.00	0.00	0.00	0.00	0.00	0.00	0.00
	5:15:00	0.00	0.00	0.00	0.00	0.00	0.00	0.00	0.00	0.00
	5:20:00	0.00	0.00	0.00	0.00	0.00	0.00	0.00	0.00	0.00
	5:25:00	0.00	0.00	0.00	0.00	0.00	0.00	0.00	0.00	0.00
	5:30:00	0.00	0.00	0.00	0.00	0.00	0.00	0.00	0.00	0.00
	5:35:00	0.00	0.00	0.00	0.00	0.00	0.00	0.00	0.00	0.00
	5:40:00	0.00	0.00	0.00	0.00	0.00	0.00	0.00	0.00	0.00
	5:45:00	0.00	0.00	0.00	0.00	0.00	0.00	0.00	0.00	0.00
	5:50:00	0.00	0.00	0.00	0.00	0.00	0.00	0.00	0.00	0.00
	5:55:00	0.00	0.00	0.00	0.00	0.00	0.00	0.00	0.00	0.00
	6:00:00	0.00	0.00	0.00	0.00	0.00	0.00	0.00	0.00	0.00





## DRAINAGE MAPS





Unresolved:  
On both maps, indicate what  
facilities are public and/or private

**NOW  
LABELED**

### FINAL DRAINAGE REPORT ~ BASIN RUNOFF COEFFICIENT SUMMARY

BASIN	TOTAL AREA (AC)	DEVELOPED AREA/IMPERVIOUS AREA				LANDSCAPE/UNDEVELOPED AREAS				WEIGHTED			WEIGHTED CA			IMPERVIOUSNESS %
		AREA (AC)	C(2)	C(5)	C(100)	AREA (AC)	C(2)	C(5)	C(100)	C(2)	C(5)	C(100)	CA(2)	CA(5)	CA(100)	
OS-10	4.10	0.60	0.89	0.90	0.96	3.50	0.03	0.09	0.36	0.16	0.21	0.45	0.64	0.86	1.84	16%
OS-11	1.70	0.80	0.89	0.90	0.96	0.90	0.02	0.08	0.35	0.43	0.47	0.64	0.73	0.79	1.08	45%
OS-12	0.51	0.27	0.89	0.90	0.96	0.24	0.03	0.09	0.36	0.49	0.52	0.68	0.25	0.26	0.35	54%
OS-13	0.67	0.40	0.89	0.90	0.96	0.27	0.03	0.09	0.36	0.54	0.57	0.72	0.36	0.38	0.48	61%
OS-14	0.28	0.15	0.89	0.90	0.96	0.13	0.03	0.09	0.36	0.49	0.52	0.68	0.14	0.15	0.19	55%
OS-15	1.60	1.20	0.89	0.90	0.96	0.40	0.03	0.09	0.36	0.68	0.70	0.81	1.08	1.12	1.30	76%
OS-16	1.00	0.70	0.89	0.90	0.96	0.30	0.02	0.08	0.35	0.63	0.65	0.78	0.63	0.65	0.78	67%
OS-17	0.53	0.43	0.89	0.90	0.96	0.10	0.03	0.09	0.36	0.73	0.75	0.85	0.39	0.40	0.45	82%
OS-18	0.30	0.30	0.89	0.90	0.96	0.00	0.03	0.09	0.36	0.89	0.90	0.96	0.27	0.27	0.29	100%
EX2	0.56	0.56	0.03	0.09	0.36	0.00	0.03	0.09	0.36	0.03	0.09	0.36	0.02	0.05	0.20	2%
EX3	1.80	1.80	0.03	0.09	0.36	0.00	0.03	0.09	0.36	0.03	0.09	0.36	0.05	0.16	0.65	2%
Exist. Trib. to Pond	13.05															

### FINAL DRAINAGE REPORT ~ BASIN RUNOFF SUMMARY

BASIN	WEIGHTED			OVERLAND			STREET / CHANNEL FLOW				Tc (min)	INTENSITY			TOTAL FLOWS			
	CA(2)	CA(5)	CA(100)	C(5)	Length (ft)	Height (ft)	Length (ft)	Slope (%)	Velocity (fps)	Length (min)		TOTAL (cfs)	I(2) (in/hr)	I(5) (in/hr)	I(100) (in/hr)	Q(2) (cfs)	Q(5) (cfs)	Q(100) (cfs)
OS-10	0.64	0.86	1.84	0.09	65	2	10.1	950	3.5%	1.9	8.5	18.6	2.56	3.20	5.37	2	3	10
OS-11	0.73	0.79	1.08	0.08	100	2	14.7	500	4.0%	2.0	4.2	18.8	2.54	3.18	5.34	1.9	3	6
OS-12	0.25	0.26	0.35	0.09	40	2	6.8	200	3.5%	3.7	0.9	7.7	3.61	4.53	7.60	0.9	1.2	3
OS-13	0.36	0.38	0.48	0.09	25	3	4.0	240	5.5%	4.7	0.9	5.0	4.12	5.17	8.68	1.5	2	4
OS-14	0.14	0.15	0.19	0.09	30	10	3.1	170	5.5%	4.7	0.6	5.0	4.12	5.17	8.68	0.6	0.8	2
OS-15	1.08	1.12	1.30	0.09	180	12	13.1	100	3.0%	1.7	1.0	14.0	2.89	3.62	6.08	3	4	8
OS-16	0.63	0.65	0.78	0.08	100	4	11.7	130	1.5%	1.2	1.8	13.4	2.94	3.69	6.19	1.9	2	5
OS-17	0.39	0.40	0.45	0.09	60	14	5.0	380	5.0%	4.5	1.4	6.4	3.82	4.80	8.05	1.5	2	4
OS-18	0.27	0.27	0.29	0.09	15	0.5	4.7	280	2.0%	2.8	1.6	6.4	3.83	4.80	8.06	1.0	1.3	2
EX2	0.02	0.05	0.20	0.09	50	2	8.2					8.2	3.54	4.43	7.44	0.1	0.2	1.5
EX3	0.05	0.16	0.65	0.09	260	5	23.7					23.7	2.27	2.84	4.76	0.1	0.5	3

### FINAL DRAINAGE REPORT ~ SURFACE ROUTING SUMMARY

Design Point(s)	Contributing Basins	Equivalent CA(5)	Equivalent CA(100)	Maximum Tc	Intensity		Flow		Inlet Size
					I(5)	I(100)	Q(5)	Q(100)	
H4	OS-12	0.26	0.46	7.7	4.53	7.60	1	3	EXIST. 5' TYPE R AT-GRADE INLET
H5	OS-13, Flow-by from H4	0.38	0.63	5.0	5.17	8.68	2	5	EXIST. 10' TYPE R AT-GRADE INLET
H6	OS-14, Flow-by from H5	0.15	0.24	5.0	5.17	8.68	1	2	EXIST. 10' TYPE R AT-GRADE INLET
H7	OS-11 and OS-16	1.45	1.86	18.8	3.18	5.34	5	10	EXIST. 10' TYPE R AT-GRADE INLET
H8	OS-17, Flow-by from H7	0.42	0.73	6.4	4.80	8.05	2	6	EXIST. 10' TYPE R AT-GRADE INLET
H9	OS-18, Flow-by from H8	0.27	0.41	6.4	4.80	8.06	1	3	EXIST. 10' TYPE R AT-GRADE INLET
H10	EX2, EX3, OS-10 thru OS-18	5.09	7.60	23.7	2.84	4.76	14	36	EXIST. 36" RCP CDOT CULVERT

### FINAL DRAINAGE REPORT ~ PIPE ROUTING SUMMARY

Pipe Run	Contributing Basins	Equivalent CA(5)	Equivalent CA(100)	Maximum Tc	Intensity		Flow		Pipe Size*
					I(5)	I(100)	Q(5)	Q(100)	
H1	Inlet Capture at DP-H4	0.26	0.24	7.7	4.53	7.60	1	2	Exist. 15' RCP
H2	PR-H1, Inlet Capture at DP-H5	0.65	0.77	7.8	4.51	7.57	3	6	Exist. 15' RCP
H3	PR-H2, Inlet Capture at DP-H6	0.80	1.01	7.9	4.49	7.54	4	8	Exist. 24" RCP
H4	OS-15	1.12	1.30	14.0	3.62	6.08	4	8	Exist. 18" ADS
H5	PR-H3, PR-H4, Portion of OS-11 and OS-16	3.20	3.95	18.8	3.18	5.34	10	21	Exist. 30" RCP
H6	Inlet Capture at DP-H8	0.42	0.64	6.4	4.80	8.05	2	5	Exist. 24" RCP
H7	Inlet Capture at DP-H9	0.27	0.41	6.4	4.80	8.06	1	3	Exist. 24" RCP

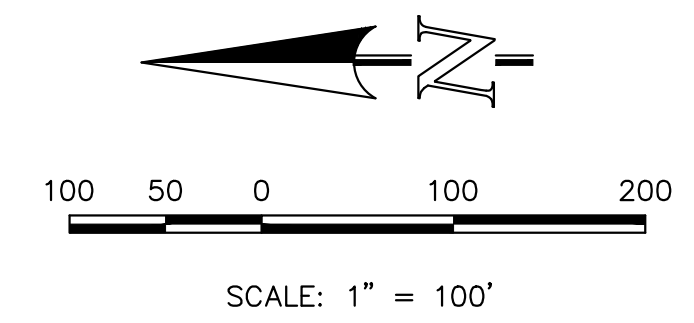
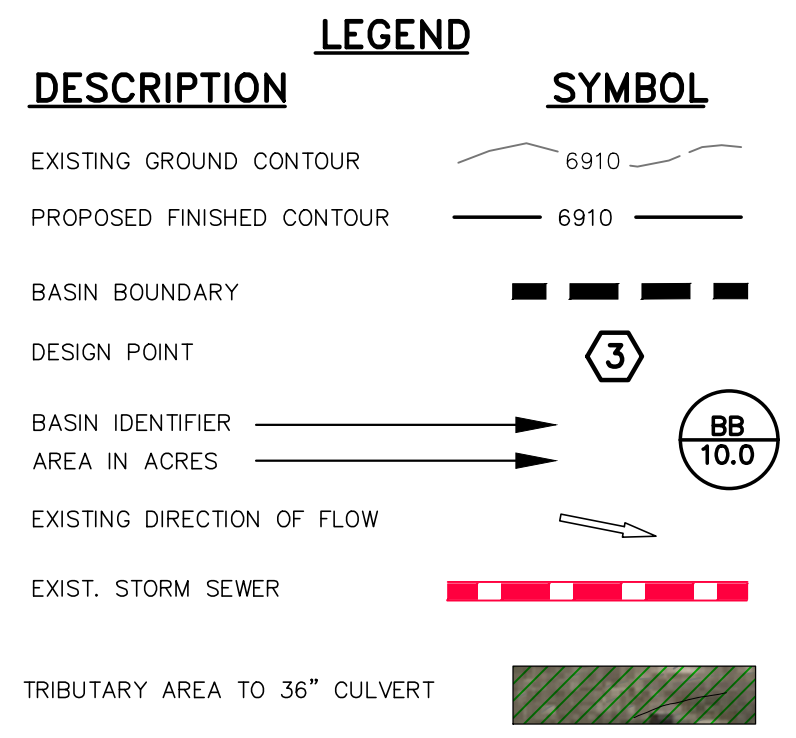

619 N. Cascade Avenue, Suite 200  
Colorado Springs, Colorado 80903

MONUMENT JUNCTION DEVELOPMENT  
HWY. 105 & JACKSON CREEK INT. IMPS.  
FINAL DRAINAGE REPORT  
PRE-DEVELOPED DRAINAGE MAP

DESIGNED BY	MAW	SCALE	DATE	03/16/22
DRAWN BY	MAW	(H) 1" = 100'	SHEET	1 OF 2
CHECKED BY	(V) 1" = N/A	JOB NO.	1302.22	

N:\130222\FINAL DRAINAGE REPORT\130222-HM.dwg, 4/5/2022, 7:26:43 AM, 11



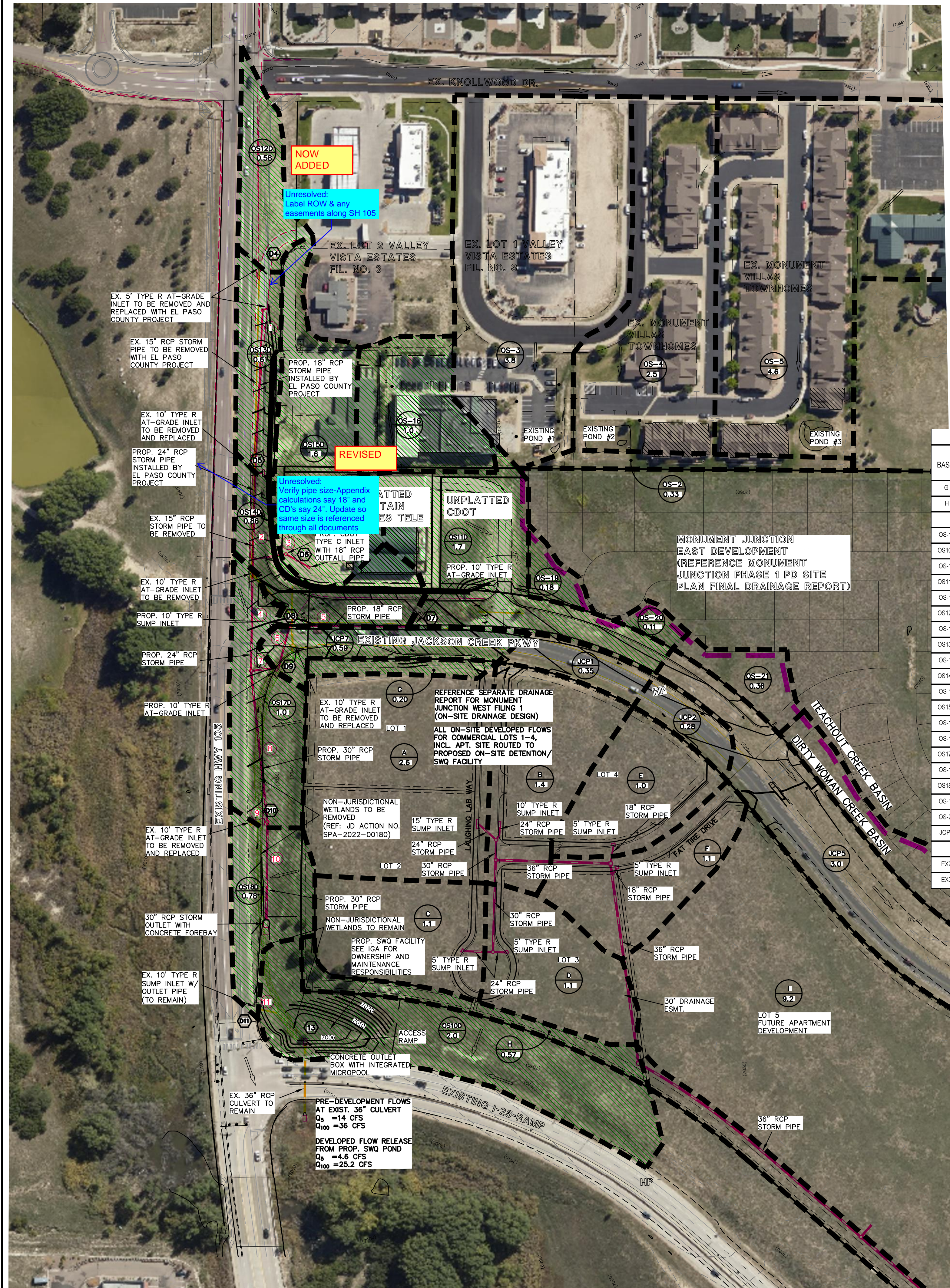

### FINAL DRAINAGE REPORT ~ BASIN RUNOFF COEFFICIENT SUMMARY

BASIN	TOTAL AREA (AC)	DEVELOPED AREA/IMPERVIOUS AREA			LANDSCAPE/UNDEVELOPED AREAS				WEIGHTED			WEIGHTED CA			IMPERVIOUSNESS %	
		AREA (AC)	C(2)	C(5)	C(100)	AREA (AC)	C(2)	C(5)	C(100)	C(2)	C(5)	C(100)	CA(2)	CA(5)		CA(100)
G	0.20	0.05	0.79	0.81	0.88	0.15	0.03	0.09	0.36	0.22	0.27	0.49	0.04	0.05	0.10	25%
H	0.57	0.05	0.79	0.81	0.88	0.52	0.03	0.09	0.36	0.10	0.15	0.41	0.06	0.09	0.23	10%
OS-10	4.10	0.60	0.89	0.90	0.96	3.50	0.03	0.09	0.36	0.16	0.21	0.45	0.64	0.86	1.84	16%
OS10D	2.00	0.10	0.89	0.90	0.96	1.90	0.03	0.09	0.36	0.07	0.13	0.39	0.15	0.26	0.78	7%
OS-11	1.70	0.80	0.89	0.90	0.96	0.90	0.02	0.08	0.35	0.43	0.47	0.64	0.73	0.79	1.08	45%
OS11D	1.70	1.20	0.89	0.90	0.96	0.50	0.03	0.09	0.36	0.64	0.66	0.78	1.08	1.13	1.33	71%
OS-12	0.51	0.27	0.89	0.90	0.96	0.24	0.03	0.09	0.36	0.49	0.52	0.68	0.25	0.26	0.35	54%
OS12D	0.58	0.31	0.89	0.90	0.96	0.27	0.03	0.09	0.36	0.49	0.52	0.68	0.28	0.30	0.39	54%
OS-13	0.67	0.40	0.89	0.90	0.96	0.27	0.03	0.09	0.36	0.54	0.57	0.72	0.38	0.38	0.48	61%
OS13D	0.67	0.40	0.89	0.90	0.96	0.27	0.03	0.09	0.36	0.54	0.57	0.72	0.38	0.38	0.48	61%
OS-14	0.28	0.15	0.89	0.90	0.96	0.13	0.03	0.09	0.36	0.49	0.52	0.68	0.14	0.15	0.19	55%
OS14D	0.86	0.72	0.89	0.90	0.96	0.14	0.03	0.09	0.36	0.75	0.77	0.96	0.65	0.66	0.74	84%
OS-15	1.60	1.20	0.89	0.90	0.96	0.40	0.03	0.09	0.36	0.68	0.70	0.81	1.08	1.12	1.30	76%
OS15D	1.60	1.20	0.89	0.90	0.96	0.40	0.03	0.09	0.36	0.68	0.70	0.81	1.08	1.12	1.30	76%
OS-16	1.00	0.70	0.89	0.90	0.96	0.30	0.02	0.08	0.35	0.63	0.65	0.78	0.63	0.65	0.78	67%
OS-17	0.53	0.43	0.89	0.90	0.96	0.10	0.03	0.09	0.36	0.73	0.75	0.85	0.39	0.40	0.45	82%
OS17D	1.00	0.60	0.89	0.90	0.96	0.40	0.03	0.09	0.36	0.55	0.58	0.72	0.55	0.58	0.72	61%
OS-18	0.30	0.30	0.89	0.90	0.96	0.00	0.03	0.09	0.36	0.89	0.90	0.96	0.27	0.27	0.29	100%
OS18D	0.78	0.43	0.89	0.90	0.96	0.35	0.03	0.09	0.36	0.50	0.54	0.69	0.39	0.42	0.54	56%
OS-19	0.18	0.00	0.89	0.90	0.96	0.18	0.03	0.09	0.36	0.03	0.09	0.36	0.01	0.02	0.06	2%
OS-20	0.11	0.01	0.89	0.90	0.96	0.10	0.03	0.09	0.36	0.11	0.16	0.41	0.01	0.02	0.05	10%
JCP7	0.59	0.50	0.89	0.90	0.96	0.09	0.03	0.09	0.36	0.76	0.78	0.87	0.45	0.46	0.51	85%
EX2	0.56	0.56	0.03	0.09	0.36	0.00	0.03	0.09	0.36	0.03	0.09	0.36	0.02	0.05	0.20	2%
EX3	1.80	1.80	0.03	0.09	0.36	0.00	0.03	0.09	0.36	0.03	0.09	0.36	0.05	0.16	0.65	2%
Exist. Trib. to Pond	13.05															37.6%
Dev. Trib. to Pond	11.84															53.6%
Dev. Trib. to Forebay	8.49															67.2%

### FINAL DRAINAGE REPORT ~ BASIN RUNOFF SUMMARY

BASIN	WEIGHTED			OVERLAND			STREET / CHANNEL FLOW			Tc (min)	INTENSITY			TOTAL FLOWS				
	CA(2)	CA(5)	CA(100)	Length (ft)	Height (ft)	Tc (min)	Length (ft)	Slope (%)	Velocity (fps)		Tc (min)	I(2) (in/hr)	I(5) (in/hr)	I(100) (in/hr)	Q(2) (cfs)	Q(5) (cfs)	Q(100) (cfs)	
G	0.04	0.05	0.10	0.09	30	1.5	5.9				5.9	3.93	4.93	8.27	0.17	0.3	0.8	
H	0.06	0.09	0.23	0.09	40	2	6.8				6.8	3.76	4.71	7.91	0.2	0.4	1.8	
OS-10	0.64	0.66	1.84	0.09	65	2	10.1	950	3.5%	1.9	8.5	18.6	2.56	3.20	5.37	2	3	10
OS10D	0.15	0.26	0.78	0.09	65	2	10.1	950	3.5%	1.9	8.5	18.6	2.56	3.20	5.37	0.4	0.8	4
OS-11	0.73	0.79	1.08	0.08	100	2	14.7	500	4.0%	2.0	4.2	18.8	2.54	3.18	5.34	1.9	3	6
OS11D	1.08	1.13	1.33	0.09	100	2	14.5	300	4.0%	2.0	2.5	17.0	2.66	3.33	5.59	3	4	7
OS-12	0.25	0.26	0.36	0.09	40	2	6.8	200	3.5%	3.7	0.9	7.7	3.61	4.53	7.60	0.9	1.2	3
OS12D	0.28	0.30	0.39	0.09	40	2	6.8	200	3.5%	3.7	0.9	7.7	3.61	4.53	7.60	1.0	1.4	3.0
OS-13	0.36	0.38	0.48	0.09	25	3	4.0	240	5.5%	4.7	0.9	5.0	4.12	5.17	8.68	1.5	2	4
OS13D	0.36	0.38	0.48	0.09	25	3	4.0	250	5.5%	3.7	1.1	5.1	4.09	5.13	8.61	1.5	2	4
OS-14	0.14	0.15	0.19	0.09	30	10	3.1	170	5.5%	4.7	0.6	5.0	4.12	5.17	8.68	0.6	0.8	2
OS14D	0.65	0.66	0.74	0.09	30	10	3.1	190	5.5%	4.7	0.7	5.0	4.12	5.17	8.68	3	3	6
OS-15	1.08	1.12	1.30	0.09	180	12	13.1	100	3.0%	1.7	1.0	14.0	2.89	3.62	6.08	3	4	8
OS15D	1.08	1.12	1.30	0.09	180	12	13.1	80	3.0%	3.5	0.4	13.5	2.94	3.68	6.18	3	4	8
OS-16	0.63	0.65	0.78	0.08	100	4	11.7	130	1.5%	1.2	1.8	13.4	2.94	3.69	6.19	1.9	2	5
OS-17	0.39	0.40	0.45	0.09	60	14	5.0	380	5.0%	4.5	1.4	6.4	3.82	4.80	8.05	1.5	2	4
OS17D	0.55	0.58	0.72	0.09	60	14	5.0	380	5.0%	4.5	1.4	6.4	3.82	4.80	8.05	2	3	6
OS-18	0.27	0.27	0.29	0.09	15	0.5	4.7	280	2.0%	2.8	1.6	6.4	3.83	4.80	8.06	1.0	1.3	2
OS18D	0.39	0.42	0.54	0.09	90	4	10.6	260	2.0%	2.8	1.5	12.1	3.07	3.84	6.45	1.2	1.6	3
OS-19	0.01	0.02	0.06	0.09	80	3.2	10.3	380	5.0%	4.5	1.4	11.7	3.10	3.89	6.53	0.02	0.1	0.4
OS-20	0.01	0.02	0.05	0.09	50	3	7.1	370	4.63	7.78	0.0	11.7	3.70	4.63	7.78	0.0	0.1	0.4
JCP7	0.45	0.46	0.51	0.09	20	0.6	5.7	300	4.5%	4.2	1.2	6.9	3.74	4.70	7.88	2	2	4
EX2	0.02	0.05	0.20	0.09	50	2	8.2				8.2	3.54	4.43	7.44	0.1	0.2	1.5	
EX3	0.05	0.16	0.65	0.09	260	5	23.7				23.7	2.27	2.84	4.76	0.1	0.5	3	

### FINAL DRAINAGE REPORT ~ SURFACE ROUTING SUMMARY

Design Point(s)	Contributing Basins	Equivalent CA(5)	Equivalent CA(100)	Maximum Tc	Intensity		Flow		Inlet Size
					I(5)	I(100)	Q(5)	Q(100)	
13	G, H, JCP7, OS10D thru OS15D, OS-16, OS17D, OS18D	5.84	7.90	21.1	3.01	5.05	18	40	CDOT SWQ FACILITY
D4	OS12D, 0.85 CFS 100Yr Flow-by from upstream	0.30	0.51	7.7	4.53	7.60	1.4	3.9	PROP. 5" TYPE R AT-GRADE INLET
D5	OS13D, Flow-by from D4	0.38	0.63	5.0	5.17	8.68	2	5	PROP. 10" TYPE R AT-GRADE INLET
D6	OS15D	1.12	1.30	13.5	3.68	6.18	4	8	PROP. CDOT TYPE C INLET
D7	OS11D, OS-16, OS-19, OS-20	1.81	2.22	17.0	3.33	5.59	6	12	PROP. 10" TYPE R AT-GRADE INLET
D8	OS14D, Flow-by from D5&D7	0.84	1.47	17.0	3.33	5.59	3	8	PROP. 10" TYPE R SUMP INLET
D9	JCP7, G	0.51	0.61	6.9	4.70	7.88	2	5	PROP. 10" TYPE R AT-GRADE INLET
D10	OS17D, Flow-by from D8	0.58	0.74	6.4	4.80	8.05	3	6	PROP. 10" TYPE R AT-GRADE INLET
D11	OS18D, Flow-by from D9	0.42	0.64	12.1	3.84	6.45	2	4	EXIST. 18" TYPE R SUMP INLET

### FINAL DRAINAGE REPORT ~ PIPE ROUTING SUMMARY

Pipe Run	Contributing Basins	Equivalent CA(5)	Equivalent CA(100)	Maximum Tc	Intensity		Flow		Pipe Size*
					I(5)	I(100)	Q(5)	Q(100)	
1	Inlet Capture at D4	0.30	0.33	7.7	4.53	7.60	1.4	2.5	PROP. 15" RCP
2	PR-1, Inlet Capture at D5	0.69	0.92	7.7	4.53	7.60	3	7	PROP. 18" RCP
3	CDOT Type C Inlet Capture at D6	1.12	1.30	13.5	3.68	6.18	4	8	PROP. 18" RCP
4	PR-2, PR-3	1.80	2.22	13.7	3.66	6.15	7	14	PROP. 24" RCP
5	Inlet Capture at D7	1.63	1.51	17.0	3.33	5.59	5	8	PROP. 18" RCP
6	PR-5, Inlet Capture at D8	2.47	2.98	17.0	3.33	5.59	8	17	PROP. 24" RCP
7	PR-6, Inlet Capture at D9	2.98	3.56	17.0	3.33	5.59	10	20	PROP. 24" RCP
8	PR-4, PR-7	4.79	5.77	17.2	3.32	5.56	16	32	PROP. 30" RCP
9	Inlet Capture at D10	0.58	0.66	6.4	4.80	8.05	3	5	PROP. 18" RCP
10	PR-8, PR9	5.36	6.43	17.4	3.30	5.54	18	36	PROP. 30" RCP
11	Inlet Capture at D11	0.42	0.64	12.1	3.84	6.45	2	4	EXIST. 18" RCP

