

ADDENDUM NO. 1 TO
STORMWATER MANAGEMENT PLAN (SWMP)
SECURITY WATER TREATMENT PLANT BUILDING ADDITION

Date of Addendum No. 1: May 22, 2026

This Addendum No. 1 is made to the Stormwater Management Plan (SWMP) prepared for J.R. Filanc Construction Company, Inc. for the Security Water Treatment Plant Building Addition, dated May 2026. The “original” SWMP was prepared by CMS Environmental Solutions, Inc. This Addendum No. 1 only addresses recent changes in the stormwater management design and construction features. The original SWMP referenced a detention pond as the primary water quality feature. The final design incorporates a bioretention (BR) pond to meet water quality capture volume (WQCV) requirements. The BR pond:

- Provides enhanced stormwater quality treatment
- Reduces runoff volume through infiltration
- Maintains hydrologic consistency with existing site conditions

This Addendum does not change the overall drainage patterns or discharge locations identified in the original SWMP, but clarifies the type and function of the permanent water quality best management practices (BMPs). All references to, “detention pond,” within the SWMP shall be interpreted as the BR pond, unless otherwise noted.

The approved Grading and Erosion Control (GEC) Plan is included in this submittal as Tab F. The GEC Plan was prepared in accordance with the El Paso County Grading and Erosion Control Plan Checklist (March 2025). Information contained within the attached GEC Plan may be referenced in lieu of duplicating plan information within this Addendum.

This Addendum is structured similarly in format to the SWMP with section and subsection numbers and titles corresponding to the SWMP. Only those sections in which additional data or new information has been developed or revisions necessary are presented. New sections/subsections addressing new features of the SWMP are also presented. This Addendum shall be attached to and shall become supplemental to the final version of the May 2026 Stormwater Management Plan for the Security Water Treatment Plant Building Addition.

Please include a placeholder tab for the signed ESQCP form (to be provided at or by pre-con meeting).

TAB A – NARRATIVE

1 INTRODUCTION

1.3 Co-Permittees

The Permit requires both the Owner and Operator as defined in the permit to be co-permittees. Both the Owner and Operator (Table 1) will be subject to the same obligations, including implementation of the SWMP. In cases where the duties of the owner and operator are managed by the owner, both signatures may be completed by the owner.

Table 1. Owner and Operator Contact Information

| Owner: | Operator: |
|----------------------------------------------------------------------------------------------------------------------------------------------------------------------------------------------------------------------------|------------------------------------------------------------------------------------------------------------------------------------------------------------------------------------------------------------------------------------------------------------------|
| Roy E. Heald General Manager Security Water District 231 Security Boulevard Colorado Springs, CO 80911 Phone: (719) 392-3475 Email: r.heald@securitywsd.com | Eric Klopfenstein General Superintendent J.R. Filanc Construction Company, Inc. 455 W. 115 th Ave., Ste. 3 Northglenn, CO 80234 Phone: (719) 660-6165 Email: eklopfenstein@filanc.com |

The Owner’s Consulting Engineer is as shown below. This organization is available at any time for coordination and communication among all Parties in this Project.

Roger J. Sams, P.E., Principal
 GMS, Inc. Consulting Engineers
 611 North Weber Street, Suite 300
 Colorado Springs, CO 80903
 Phone: 719-659-4153
 Email: rsams@gmsengr.com

4 IMPLEMENTATION OF CONTROL MEASURES USED TO MEET EFFLUENT LIMITATIONS

4.2 Control Measures for Erosion and Sediment Control

Table 8. Permit-Specific Control Measure Requirements

| Requirement | Planned Control Measure |
|----------------------------------------------------------------------------------------------------------------------------------------------------------------------------------------------------|-------------------------------------------------------------------------------------------------------|
| Part I.B.1.a.i.(a). Vehicle tracking controls must be implemented to minimize vehicle tracking of sediment from disturbed areas. Vehicle tracking controls must include a structural measure (e.g. | Vehicle tracking control measures are addressed in Table 7, in Section 3 of the SWMP and shown on the |

| Requirement | Planned Control Measure |
|-----------------------------------------------------------------------------------------------------------------------------------------------------------------------------------------------------------------------------------------------------------------------------------------------------------------------------------------------------------------------------------------------------------------------------------------------------------------------------------------------------------------------------------------------------------------------------------------------------------------------------------------------------------------------------------------------------------------|---------------------------------------------------------------------------------------------------------------------------------------------------------------------------------------------------------------------------------------------------------------------------------------------------------------------------------------------------------------------------------------------------------------------------------------------------------------------------------------------------------------------------------------------------------------------------------------------------------------------------------------------------------------------------------------------------------------------------------------------------------------------------------------------------------------------------------------------------------------------------------------------------------------------------------------------------------------|
| tracking pad or wash rack) and may include a nonstructural control measure (e.g. sweeping or restricting vehicle traffic to paved areas). | Site Map. Also reference the Control Measure Details section on SW2. |
| Part I.B.1.a.i.(b). Stormwater runoff from all disturbed areas must utilize or flow to one or more control measures to minimize sediment in the discharge. This may be accomplished through filtering, settling, or straining. The control measure must be selected, designed, installed, and adequately sized in accordance with good engineering, hydrologic, and pollution control practices for the intended application. The control measure(s) must contain or filter flows in order to prevent the bypass of flows without treatment and must be appropriate for stormwater runoff from disturbed areas and for the expected flow rate, duration, and flow conditions (i.e. sheet or concentrated flow). | The control measures presented in the Security Water District and El Paso County approved grading, erosion and sediment control (GESC) plans prepared by GMS, Inc. and updated Site Maps attached to this Addendum consists of one or more control measures that treat flows to minimize sediment in the discharge. The permanent water quality facilities include a BR pond constructed in the southwestern portion of the site, which may function as a temporary sediment basin during initial phases of construction where feasible. The BR pond will only be utilized as a temporary sediment basin prior to installation of engineered media and vegetation, and will be isolated from sediment-laden flows once treatment media is installed. The underdrain will help filter and discharge the attenuated flow back onto District-owned property. Reference the current Site Map and associated Control Measure Details sections on SW ² . |
| Part I.B.1.a.i.(c). Selection of control measures should prioritize the use of control measures that minimize the potential for erosion (i.e. covering materials). Selection should also prioritize phasing construction activities to minimize the amount of soil disturbance at any point in time throughout the duration of construction. | The approved GESC plan utilizes measures to minimize the potential for erosion and incorporates phasing to minimize the amount of soil disturbed at any point in time to the maximum extent practicable. |
| Part I.B.1.a.i.(d). Outlets that withdraw water from or near the surface shall be installed when discharging from basins and impoundments, unless infeasible. | The planned BR pond designed for water quality capture volume (WQCV) treatment, located in the southwestern corner of the site, discharges directly northwest to existing Security Water District Little Johnson Reservoir and will be used as a temporary sediment basin in the initial and interim phases of this plan. The bioretention pond includes engineered media, infiltration, and an underdrain system to treat runoff prior to discharge in conformance to El Paso County BMP detail requirements. |
| Part I.B.1.a.i.(e). Maintain pre-existing vegetation for areas within 50 horizontal feet of receiving waters as defined by this permit, unless | The project does not have receiving waters or areas within 50 horizontal feet of a receiving water within the project boundary. |

| Requirement | Planned Control Measure |
|-------------------------------------------------------------------------------------------------------------------------------------------------------------------------------------------------------------------------------------------------------------------------------------------------------------------------------------------------------------------------|--------------------------------------------------------------------------------------------------------------------------------------------------------------------------------------------------------------------------------------------------------------------------------------------------------------------------------------------------------------------------------------------------------------------------------------------------------------------------------------------------------------------------------------------------------------------------------------------------------------------------------------------------------------------------------------------------------------------------------------------------------------------------------------------------------------------------------------------------------------------------------------------------------------------------------------------------------------------------|
| <p>infeasible. In addition to maintaining 50 horizontal feet of pre-existing vegetation upgradient of a receiving water (unless infeasible), the permittee must install control measures upgradient of the vegetative buffer that meets the requirements of this section.</p> | |
| <p>Part I.B.1.a.i.(f). Soil compaction must be minimized for areas where infiltration control measures will occur or where final stabilization will be achieved through vegetative cover. If compaction does occur in areas where final stabilization will be achieved through vegetative cover, then decompaction of the soil must be completed prior to planting.</p> | <p>Soil compaction may be minimized by limiting points of ingress and egress within the project. Typical and unavoidable equipment wheels or tracks in contact with soil throughout the site is not considered soil compaction for purposes of this definition. If compaction does occur in areas where final stabilization will be achieved through vegetative cover, then decompaction of the soil must be completed prior to planting. Compaction efforts shall be applied in areas deemed necessary by the soils engineer, public works, or building division.</p> |
| <p>Part I.B.1.a.i.(g). Unless infeasible, topsoil shall be preserved for those areas of a site that will utilize vegetative final stabilization. Preserved topsoil can be left in place or stockpiled.</p> | <p>Preserve topsoil for those areas of a site that will utilize vegetative final stabilization, unless infeasible. A common example includes tracts that are to be revegetated. Areas of stockpiled topsoil will be noted on the active Site Map, or if preservation is infeasible, the reasons will be added to the SWMP.</p> <p>The BR surface consists of an engineered BR media conforming to the gradation and composition requirements of Table BR-3, Chapter 4 of the Mile High Flood District Urban Storm Drainage Criteria Manual. The media surface will be seeded with native, drought-tolerant grasses adapted to both periodic inundation and dry conditions. Full vegetative cover will promote filtration, prevent erosion, and promote long term treatment performance.</p> <p>Final stabilization for vertical construction will utilize landscaping, sod, and/or hardscaping therefore preserving topsoil does not apply to vertical construction.</p> |
| <p>Part I.B.1.a.i.(h). Minimize the amount of soil exposed during construction activity, including the disturbance of steep slopes.</p> | <p>The Permit requires minimizing the amount of soil exposed during construction. Phasing is implemented on this project that minimizes disturbance to the extent practicable. Steep slopes are defined as 3:1 or greater where no other definition exists.</p> |

| Requirement | Planned Control Measure |
|------------------------------------------------------------------------------------------------------------------------------------------------------------------------------------------------------------------------------------------------------------------------------------------------------------------------------------------------------------------------------------------------------------------------------------------------------------------------------------------------------------------------------------------------------------------------------------------------------------------------------------------------------------------------------------------------------------------------------------------------------------------------------------------------------------------------------------------------------------------------------------------------------------------------------------------------------------------------------------------------------------------------------------------------------------------------------------------------------------------------------------------------------------------------------------------------------------------------------------------------------------------------------------------------------------------------------------------------------------------------------------------------------------------------------------------------------------------------------------------------------------------------------------------------------------------------------------------------------------------------------------------------------------------------------------------------------------------------------------------------------------------------------------------------------------------------------------------------------------------------------------|----------------------------------------------------------|
| <p>Part I.B.1.a.i.(i). Diversion control measures used for clean water diversions must minimize soil transport and erosion within the entire diversion, minimize erosion during discharge, and minimize run-on into the diversion. The permittee must minimize the discharge of pollutants throughout the installation, implementation, and removal of the diversion. Diversions must meet one or more of the following conditions:</p> <ol style="list-style-type: none"> (1) Lined or piped structures that result in no erosion for anticipated flow conditions. (2) Diversion channels, berms, and coffer dams must be lined or composed of a material that minimizes potential for soil loss in the entire wetted perimeter during anticipated flow conditions (e.g. vegetated swale, non-erosive soil substrate). The entire length of the diversion channel must be designed with all of the following considerations: maximum flow velocity for the type of material(s) exposed to the anticipated flows to ensure that the calculated maximum shear stress of flows in the channel is not expected to result in physical damage to the channel or liner and result in discharge of pollutants. Additionally, the conditions relied on to minimize soil loss must be maintained for the projected life of the diversion (i.e. a vegetated swale must be limited to a period of time that ensures vegetative growth, minimizes erosion, and maintains stable conditions). (3) An alternative diversion criteria, approved by the division prior to implementation. The diversion method must be designed to minimize the discharge of pollutants and to prevent the potential for pollution or degradation to state waters as a result of the diverted flow through the diversion structure. In addition, the alternative diversion method | <p>There are no anticipated diversions on this site.</p> |

| Requirement | Planned Control Measure |
|--------------------------------------------------------------------------------------------------------------------------------------------------------------------------------------------------------------------------------------------------------------------------------------------------------|-----------------------------------------------------------------------------------------------------------------------------------------------------------------------------------------------------------------------------------------------------------------------------------------------------------------------------------------------------------------------------------------------------------------------------------------------------------------------------------------------------------------------------------------------------------------------------------------------------------------------------------------------------------------------------------------------------------------------------------------------------------------------------------------------------------------------------------------------------------------------------------------------|
| <p>must minimize the discharge of pollutants throughout the installation, implementation, and removal of the diversion.</p> | |
| <p>Part I.B.1.a.i.(j). Minimize Dust. On areas of exposed soil, minimize dust through the appropriate application of water or other dust suppression techniques. Water application must be conducted in a manner to prevent discharge offsite unless authorized by a separate CDPS or NPDES permit</p> | <p>Dust suppression waters or other dust suppression techniques will be applied in an appropriate manner that will not allow water to leave the site or enter a state water. Also reference the Control Measure Details section.</p> |
| <p>Part I.B.1.a.i.(k). Control stormwater discharges, including both peak flowrates and total stormwater volume, to minimize channel and streambank erosion and scour in the immediate vicinity of discharge points</p> | <p>Upgradient straw wattles, inlet protections and a planned permanent BR pond, which attenuates peak flows and provides water quality treatment, will be installed at the site's ultimate discharge location. These stormwater control measures are located within the project boundary and at discharge points leaving the site during land development activities throughout vertical completion and landscaping.</p> <p>J. R. Filanc Construction Company, Inc. will be responsible for maintaining upgradient control measures and will inspect and clean/clear as necessary to ensure proper function. The discharge locations will be inspected and cleaned/cleared as necessary to ensure proper functionality. Following the completion and acceptance of construction, the Owner, the Security Water District, will be responsible for maintaining upgradient control measures.</p> |

5 SITE DESCRIPTION

5.1 Nature of Construction Activity

J.R. Filanc Construction Company, Inc. plans to perform land development activities and vertical operations for the Security Water Treatment Plan Building Addition. Work will consist of land development, installing utilities, installing curb and gutter, paving, installing water quality drainage features (swales, culverts and a BR pond system), and completing vertical construction. Soil disturbing activities include clearing, grubbing, grading, utility work, road construction, foundation

excavation and stockpiling, foundation backfill and compaction, and commercial pad building activities and staging, until final stabilization (landscaping) is complete.

5.2 Schedule and Sequence of Major Construction Activities and the Planned Implementation of Control Measures for Each Phase

Estimated Project Start Date: 09/2025

Estimated Project Completion Date: 11/2026

The following table describes the sequencing of the project as well as the planned control measures for each phase. Specific locations of control measures are shown on the Site Maps Section 6). Potential Pollutants for the project are described in Section 3, and installation and maintenance specifications for each control measure are described in Section 4 and the Control Measure Details section on SW2. It is always important to plan accordingly and minimize disturbed areas to the maximum extent practicable through proper planning.

Table 10. Commercial Land and Vertical Development Sequencing

| Phase – Construction Activity and Planned Control Measures | Anticipated Start Date | Anticipated End Date |
|--------------------------------------------------------------------------------------------------------------------------------------------------------------------------------------------------------------------------------------------------------------------------------------------------------------------------------------------------------------------------------------------------------------------------------------------------------------------|-------------------------------------------------------------------------------------------------------------------------------------------------------------------------------------|----------------------|
| Pre-Construction - Obtain permits - Pre-construction meeting or equivalent | Permit Issued: Precon: Est. Start Work: 08/2026 | 6/2026 |
| Phase I - Mobilize Equipment, Install Initial Control Measures, Demo, Clearing & Grubbing - Install vehicle tracking control measures - Install perimeter sediment controls - Install staging areas, dumpsters and portable sanitary facilities - Install inlet protections on existing storm inlets - Install temporary sediment basins - Maintain pre-existing vegetation wherever possible - Preserve topsoil unless infeasible | <div style="border: 1px solid black; padding: 2px; width: fit-content;"> Are these supposed to be 2026? Construction dates should be future </div> 10/2025 | 10/2025 |
| Phase II - Grading, Utilities, Infrastructure, Paving, Permanent Water Quality Facilities - Maintain sediment controls throughout site - Maintain existing inlet protections - Implement stockpile management - Surface roughening - Dust control - Concrete washout area must be implemented prior to use of concrete or masonry materials | 11/2025 | 11/2026 |

| Phase – Construction Activity and Planned Control Measures | Anticipated Start Date | Anticipated End Date |
|--------------------------------------------------------------------------------------------------------------------------------------------------------------------------------------------------------------------------------------------------------------------------------------------------------------------------------------------------------------------------------------------------------------------------------------------------------------------------------------------------------------------------------------------------------------------------------------------------------------------------------------------------------------------------------------------------------------------------------------------------------------------------------------------------------------------------------------------------------------------------------------------------------------------------------------------------------------------------------------------------------------------------------------------------------------------------------------------------------------------------------------------------------------------------------------------------------------------------------------------------------------------------------------------------------------------------------------------------------------------------------------------------------------------------------------------------------------------------------------------------------------------------------------------------------------------------------------|------------------------|----------------------|
| <ul style="list-style-type: none"> - Once new storm inlets are installed, install inlet protection - Street sweeping - Implement good housekeeping - Install back of curb controls after paving - Implement stabilization measures as appropriate - Install BR pond subgrade, underdrain system, and inlet/outlet structures. | | |
| <p>Phase III - Vertical Construction</p> <p>A. Install Initial Control Measures, Excavation, Foundation Installation and Backfill</p> <ul style="list-style-type: none"> - Maintain or install back of curb controls - Install or maintain inlet protections - Install dumpsters and portable sanitary facilities - Implement vehicle tracking control measures - Locate and protect stockpiles as needed - Install or maintain concrete washout area for project - Maintain perimeter controls and inlet protections - Street sweeping - Implement good housekeeping, maintain dumpsters and portable sanitary <p>B. Frame, Roof, Exterior Siding and Masonry, Interior Finishes</p> <ul style="list-style-type: none"> - Maintain sediment controls as appropriate - Maintain inlet protections - Implement material handling control measures - Use secondary containment for mixing operations. Berms to be used for masonry mixing operations. Tarps, trays, "kiddie pools", or equivalent to be used when mixing liquids (ex: drywall, paint, stains, etc.) - Street sweeping - Implement good housekeeping, maintain dumpsters and portable sanitary - Immediately install roof drainage gutters and downdrains following installation of roof sheeting. Install, operate and maintain flexible piping to convey roof runoff to planned routing through the temporary sediment control basin | 01/2026 | 09/2026 |
| <p>Phase IV - Final Stabilization</p> <ul style="list-style-type: none"> - Provide final stabilization for disturbed areas. Stabilize with seed, mulch, sod, rock, or paving per landscaping plan. - Install engineered bioretention media and vegetation once contributing drainage areas are stabilized | 11/2026 | 12/2026 |
| <p>Post-Construction</p> <ul style="list-style-type: none"> - Once all areas have been stabilized, remove any remaining sediment control devices and permanently stabilize those areas disturbed by this process - File Notice of Termination with the CDPHE | 11/2026 | 02/2027 |

5.3 Estimate of Total and Disturbed Acreage

The total area of the project site is – 3.5 acres.

Total area of the project disturbance from construction activities is – 2.3 acres.

Note: The remaining undisturbed area includes the existing soil spoils area, which will not be disturbed as part of this project. The revised acreage reflects an updated project boundary definition that is consistent with the BR limits.

Reference the most recent site inspection report for approximate current acreage disturbed.

5.4 Soils and Potential for Soil Erosion

NRCS soils data was obtained for the site. The existing soils on site are Blakeland loamy sand, 1 to 9 percent slopes.

Table 12. Soil Attributes for this Project

| Map Symbol and soil name | Pct of AOI | Hydrologic Group | Kf | T factor | % Sand | % Silt | % Clay | WEG Rating |
|-----------------------------------------------|------------|------------------|-----|----------|--------|--------|--------|------------|
| 8-Blakeland loamy sand, 1 to 9 percent slopes | 82.5 | | | | | | | 2 |
| Blakeland | | A | .10 | 5 | 85.3 | 9.2 | 5.5 | |
| Water | 17.5 | - | - | - | - | - | - | - |

Group A soils are well drained soils. An erosion factor (Kf) of 0.10 represents an extremely low susceptibility to sheet and rill erosion. Refer to Tables 7 and 8 of this narrative for practices and control measures implemented to help stop/slow down soil erosion. Also, refer to sections 4.4 and 4.5 for practices and controls measures to be used to stabilize the site once areas reach final grade and/or construction activities cease.

For a detailed explanation of the erosive properties of these soils, see the full NRCS report in the Soils section on SW².

5.8 Receiving Waters

Drainage Patterns:

Stormwater generally drains overland and in sheet flow away from high points at the center of the site, northeast, northwest and southwest, entering planned and existing drainage swales that flow around the perimeter of the site. These planned and existing stormwater piping (culverts) and drainage swales discharge southwest to the planned BR pond. Runoff is treated on-site via a BR pond prior to discharge to the downstream retention area within the District property,

controlling erosion and sediment transport. Runoff infiltrates into the engineered media and discharges out of an underdrain towards the existing Security Water District's Little Johnson Reservoir. No direct discharge to state waters occurs from the site. Runoff is treated and conveyed across District-owned property.

The District's WTP resides in the Little Johnson Drainage Basin which drains to the Windmill Gulch Basin upstream of its confluence with Fountain Creek. The Security-Widefield area generally drains southwest towards Fountain Creek, which is ultimately tributary to the Arkansas River.

Does the site discharge to a Municipal Separate Storm Sewer System (MS4)?: Yes No

Is the site within the jurisdiction's MS4 permitted area?: Yes No

If yes, list the permitted MS4 name and permit number: El Paso County MS4 - COR090011

Immediate Receiving Waters

Name: El Paso County MS4, retained at Little Johnson Reservoir Owned by the Project Owner, the Security Water District

Proximity to site: on-site, and approximately 1.1 miles southwest respectively

Ultimate Receiving Waters

Name: Arkansas River

Proximity to site: approximately 36.8 miles south

Is the immediate receiving water a designated Outstanding Water? Yes No

If yes, see inspection frequency in Section 9.

Is the immediate receiving water (excluding the MS4) within the project area? Yes No

If yes, maintain pre-existing vegetation or equivalent control measures for areas within 50 horizontal feet of the receiving water, unless infeasible. See Section 4.

Are the immediate receiving waters on the 303(d) list of impaired waters: Yes No

Impaired Receiving Waters

Name: Fountain Creek, all tributaries

Cause of impairment: Escherichia Coli (E. Coli)

Are the immediate receiving waters subject to TMDLs: Yes No

7.2 Long-Term Water Quality Management

Long-term stormwater management for the project will utilize a BR pond located in the southwestern portion of the site. The BR facility is designed to:

- Capture and treat the water quality capture volume (WQCV)
- Promote infiltration through engineered soil media
- Provide pollutant removal through filtration, adsorption, and biological processes
- Convey excess flows via an underdrain system and stabilized overflow spillway

This approach is consistent with the project drainage report and applicable El Paso County stormwater criteria. The downstream pond within the District property provides additional storage and attenuation for larger storm events.

11.1 SWMP ADDENDUM No. 1 PREPARER STATEMENT

This is to certify that this Addendum No. 1 was prepared in accordance with the Clean Water Act. This document was also prepared in accordance with the Colorado Department of Public Health and Environment General Permit for Stormwater Discharges Associated with Construction Activities COR400000. This plan was prepared in accordance with good engineering, hydrologic, and pollution control practices.

Signature:

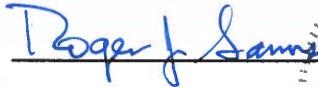

Date: 06/01/2026

Name:

Roger J. Sams, P.E.

Title:

Principal

Company:

For and on behalf of Meyer & Sams, Inc., dba GMA, Inc.



12.1 SWMP ADDENDUM No. 1 PREPARER STATEMENT

This SWMP Addendum No. 1 was prepared in accordance with applicable stormwater regulations. This document represents a planning tool to assist the SWMP Owner and Operator to comply with all applicable stormwater regulations during the construction of the project.

It is the Operator's sole responsibility on how to operate the construction site and not GMS, Inc. Consulting Engineers. Therefore, GMS, Inc. Consulting Engineers is not liable for operational decisions made by the Operator and for the Operator's failure to follow recommendations as outlined in this SWMP Addendum No. 1.

By accepting the SWMP Addendum No. 1 the Owner and Operator agrees to this disclaimer and its conditions.

TAB B – APPROVED GEC PLAN & ACTIVE SITE MAP

STANDARD NOTES FOR EL PASO COUNTY GRADING AND EROSION CONTROL PLANS

- NOTWITHSTANDING ANYTHING DEPICTED IN THESE PLANS IN WORDS OR GRAPHIC REPRESENTATION, ALL DESIGN AND CONSTRUCTION RELATED TO ROADS, STORM DRAINAGE, AND EROSION CONTROL SHALL CONFORM TO THE STANDARDS AND REQUIREMENTS OF THE MOST RECENT VERSION OF THE RELEVANT ADOPTED EL PASO COUNTY (EPC) STANDARDS, INCLUDING THE LAND DEVELOPMENT CODE (LDC), THE ENGINEERING CRITERIA MANUAL (ECM), THE DRAINAGE CRITERIA MANUAL (DCM) VOLUME 1 AND 2. ANY DEVIATIONS FROM REGULATIONS AND STANDARDS MUST BE REQUESTED, AND APPROVED, IN WRITING.
- A PRECONSTRUCTION MEETING BETWEEN THE PERMIT HOLDER(S) AND EL PASO COUNTY SHALL BE HELD PRIOR TO ANY CONSTRUCTION ACTIVITIES. IT IS THE RESPONSIBILITY OF THE PERMIT HOLDER(S) TO COORDINATE THE MEETING TIME AND PLACE WITH COUNTY STAFF. NO LAND DISTURBANCE OR CONSTRUCTION ACTIVITIES BEYOND THE INSTALLATION OF THE INITIAL CONSTRUCTION CONTROL MEASURES (CCMS), AS INDICATED ON THE APPROVED GEC PLAN OR CDS WITH GEC PLANS, MAY OCCUR PRIOR TO RECEIVING A NOTICE TO PROCEED (NTP) ISSUED BY THE EPC ADMINISTRATOR. FAILURE TO OBTAIN A NOTICE TO PROCEED PRIOR TO BEGINNING LAND DISTURBING ACTIVITIES MAY RESULT IN AN IMMEDIATE STOP WORK ORDER (SWO).
- CONSTRUCTION CONTROL MEASURES MUST BE INSTALLED PRIOR TO COMMENCEMENT OF ACTIVITIES THAT COULD CONTRIBUTE POLLUTANTS TO STORMWATER. STORMWATER RUNOFF FROM ALL DISTURBED AREAS AND SOIL STORAGE AREAS MUST UTILIZE OR FLOW TO ONE OR MORE CCM(S) TO MINIMIZE EROSION OR SEDIMENT IN THE DISCHARGE. THE CCM(S) MUST CONTAIN OR FILTER FLOWS IN ORDER TO PREVENT THE BYPASS OF FLOWS WITHOUT TREATMENT AND MUST BE APPROPRIATE FOR STORMWATER RUNOFF FROM DISTURBED AREAS AND FOR THE EXPECTED FLOW RATE, DURATION, AND FLOW CONDITIONS (E.G., SHEET OR CONCENTRATED FLOW).
- ALL CCM(S) SHALL BE MAINTAINED AND REMAIN IN EFFECTIVE OPERATING CONDITION UNTIL FINAL STABILIZATION IS ACHIEVED. THE QUALIFIED STORMWATER MANAGER (OSM) SHALL ASSESS THE ADEQUACY OF CCM(S) AT THE SITE AND IDENTIFY IF CHANGES TO THOSE CCM(S) ARE NEEDED TO ENSURE THE CONTINUED EFFECTIVE PERFORMANCE OF THE CCM(S).
- PRIOR TO CONSTRUCTION THE PERMIT HOLDER(S) SHALL VERIFY THE LOCATION OF EXISTING UTILITIES.
- MANAGEMENT OF THE STORMWATER MANAGEMENT PLAN (SWMP) DURING CONSTRUCTION IS THE RESPONSIBILITY OF THE DESIGNATED OSM. THE SWMP SHALL BE LOCATED ON-SITE OR DIGITALLY ACCESSIBLE AT ALL TIMES DURING CONSTRUCTION ACTIVITIES AND MUST BE IMPLEMENTED AS WRITTEN FROM THE START OF CONSTRUCTION ACTIVITY UNTIL FINAL STABILIZATION IS ACHIEVED. THE OSM SHALL AMEND THE SWMP WHEN THERE IS A CHANGE IN DESIGN, CONSTRUCTION, OPERATION, OR MAINTENANCE OF THE SITE WHICH WOULD REQUIRE THE IMPLEMENTATION OF NEW OR REVISED CCM(S) OR IF THE SWMP PROVES TO BE INEFFECTIVE IN CONTROLLING POLLUTANTS IN STORMWATER RUNOFF ASSOCIATED WITH CONSTRUCTION ACTIVITY OR WHEN CCM(S) ARE NO LONGER NECESSARY AND ARE REMOVED. THE OSM SHALL MAINTAIN A RECORD OF AMENDMENTS MADE TO THE SWMP THAT INCLUDES THE DATE AND IDENTIFICATION OF THE CHANGES.
- EARTH DISTURBANCES SHALL BE CONDUCTED IN SUCH A MANNER SO AS TO EFFECTIVELY MINIMIZE ACCELERATED SOIL EROSION AND RESULTING SEDIMENTATION. ALL DISTURBANCES SHALL BE DESIGNED, CONSTRUCTED, AND COMPLETED SO THAT THE EXPOSED AREA OF ANY DISTURBED LAND SHALL BE LIMITED TO THE SHORTEST PRACTICAL PERIOD OF TIME. PRE-EXISTING VEGETATION SHALL BE PROTECTED AND MAINTAINED WITHIN 50 HORIZONTAL FEET OF A RECEIVING WATER UNLESS SHOWN TO BE INFEASIBLE AND SPECIFICALLY REQUESTED AND APPROVED. IN ADDITION TO MAINTAINING 50 HORIZONTAL FEET OF PRE-EXISTING VEGETATION UPGRADIENT OF A RECEIVING WATER (UNLESS INFEASIBLE AND APPROVED), THE PERMIT HOLDER(S) MUST INSTALL CCM(S) UPGRADIENT OF THE VEGETATIVE BUFFER.
- TEMPORARY STABILIZATION MEASURES SHALL BE IMPLEMENTED ON DISTURBED AREAS AND STOCKPILES WHERE GROUND DISTURBING CONSTRUCTION ACTIVITY HAS PERMANENTLY CEASED OR TEMPORARILY CEASED FOR LONGER THAN 14 DAYS.
- EROSION CONTROL BLANKET (ECB) OR OTHER APPROVED CONTROL MEASURE(S) SHALL BE USED ON SLOPES STEEPER THAN 3:1.
- VEHICLE TRACKING CONTROLS (VTC) MUST BE IMPLEMENTED TO MINIMIZE VEHICLE TRACKING OF SEDIMENT FROM DISTURBED AREAS. VTC'S MUST INCLUDE A STRUCTURE CONTROL MEASURE (E.G., TRACKING PAD) AND MAY INCLUDE A NON-STRUCTURAL CONTROL MEASURE (E.G., SWEEPING). MATERIAL TRACKED OFF-SITE SHALL BE CLEANED UP AND PROPERLY DISPOSED OF IMMEDIATELY.
- ANY TEMPORARY OR PERMANENT CONTROL MEASURE DESIGNED AND CONSTRUCTED FOR THE CONVEYANCE OF STORMWATER AROUND, THROUGH, OR FROM THE EARTH DISTURBANCE AREA SHALL BE A STABILIZED CONVEYANCE DESIGNED TO MINIMIZE EROSION AND THE DISCHARGE OF SEDIMENT OFF-SITE.
- NO PERSON SHALL CAUSE THE IMPEDIMENT OF STORMWATER FLOW IN THE CURB AND GUTTER, PERMANENT CONTROL MEASURES (PCMS), OR DITCHES EXCEPT WITH APPROVED SEDIMENT CONTROL MEASURES.
- ALL PCMS SHALL BE INSTALLED AS DESIGNED IN THE APPROVED PLANS. ANY PROPOSED CHANGES THAT AFFECT THE DESIGN OR FUNCTION OF PCMS MUST BE APPROVED BY THE EPC ADMINISTRATOR PRIOR TO IMPLEMENTATION.
- SOIL COMPACTION MUST BE MINIMIZED IN AREAS WHERE INFILTRATION PCMS WILL BE INSTALLED OR IN AREAS WHERE FINAL STABILIZATION WILL BE ACHIEVED BY VEGETATIVE COVER. AREAS DESIGNATED FOR INFILTRATION PCMS SHALL ALSO BE PROTECTED FROM SEDIMENTATION DURING CONSTRUCTION UNTIL FINAL STABILIZATION IS ACHIEVED. IF SOIL COMPACTION DOES OCCUR IN AREAS WHERE FINAL STABILIZATION WILL BE ACHIEVED BY VEGETATIVE COVER OR IN AREAS WHERE INFILTRATION PCMS WILL BE INSTALLED, DECOMPACTION OF THE SOIL MUST BE COMPLETED PRIOR TO PLANTING OR INSTALLATION OF THE PCMS). AN INFILTRATION TEST MUST BE CONDUCTED FOR ALL INFILTRATION PCMS AND THE INFILTRATION TEST RESULTS SUBMITTED TO EL PASO COUNTY PRIOR TO PRELIMINARY ACCEPTANCE (PA).
- FINAL STABILIZATION MUST BE IMPLEMENTED AT ALL APPLICABLE CONSTRUCTION SITES. FINAL STABILIZATION IS ACHIEVED WHEN ALL GROUND DISTURBING ACTIVITIES AT THE SITE HAVE BEEN COMPLETED AND PERMANENT STABILIZATION METHODS ARE COMPLETE. WHEN USING VEGETATIVE COVER AS A PERMANENT STABILIZATION METHOD, THE VEGETATION SHALL BE EVENLY DISTRIBUTED PERENNIAL VEGETATION AND OF THE VARIETY AND SPECIES FOUND IN THE COUNTY-APPROVED SEED MIXES OR IN THE APPROVED GEC PLAN. VEGETATION COVERAGE SHALL BE, AT A MINIMUM, EQUAL TO 70% OF WHAT WOULD HAVE BEEN PROVIDED BY NATIVE VEGETATION IN A LOCAL, UNDISTURBED AREA OR ADEQUATE REFERENCE SITE. ALL TEMPORARY CCM(S) SHALL BE REMOVED UPON FINAL STABILIZATION AND PRIOR TO STORMWATER PERMIT TERMINATION.
- STORMWATER DISCHARGES FROM CONSTRUCTION SITES SHALL NOT CAUSE OR THREATEN TO CAUSE POLLUTION, CONTAMINATION, OR DEGRADATION OF STATE WATERS. ALL WORK AND EARTH DISTURBANCE SHALL BE DONE IN A MANNER THAT MINIMIZES POLLUTION OF ANY ON-SITE OR OFF-SITE WATERS, INCLUDING WETLANDS.
- CONCRETE WASH WATER SHALL BE CONTAINED AND DISPOSED OF IN ACCORDANCE WITH THE SWMP. NO WASH WATER SHALL BE DISCHARGED TO OR ALLOWED TO BE DISCHARGED OFF-SITE OR TO ENTER STATE WATERS, INCLUDING ANY SURFACE OR SUBSURFACE STORM DRAINAGE SYSTEM OR CONTROL MEASURES. CONCRETE WASHOUT AREAS SHALL NOT BE LOCATED IN AN AREA WHERE SHALLOW GROUNDWATER MAY BE PRESENT, OR WITHIN 50 FEET OF A SURFACE WATER BODY, CREEK, OR STREAM.
- DURING CONSTRUCTION DEWATERING OPERATIONS, UNCONTAMINATED GROUNDWATER MAY BE DISCHARGED ON-SITE IN ACCORDANCE WITH THE COLORADO DEPARTMENT OF PUBLIC HEALTH AND ENVIRONMENT'S (CDPHE) LOW RISK DISCHARGE GUIDANCE POLICY FOR DISCHARGES OF UNCONTAMINATED GROUNDWATER TO LAND. IF CONSTRUCTION DEWATERING OPERATIONS ARE UNABLE TO MEET ALL CRITERIA, CONDITIONS, AND CONTROL MEASURE REQUIREMENTS OF THE LOW RISK DISCHARGE GUIDANCE POLICY, A COLORADO DISCHARGE PERMIT SYSTEM (CDPS) GENERAL PERMIT CDG080000 WILL BE REQUIRED.
- CONTRACTOR SHALL BE RESPONSIBLE FOR THE REMOVAL OF ALL WASTE FROM THE CONSTRUCTION SITE FOR DISPOSAL IN ACCORDANCE WITH LOCAL AND STATE REGULATORY REQUIREMENTS. NO CONSTRUCTION DEBRIS, TREE SLASH, BUILDING MATERIAL WASTES, OR UNUSED BUILDING MATERIALS SHALL BE BURIED, DUMPED, OR DISCHARGED AT THE SITE.
- THE PERMIT HOLDER(S) SHALL BE RESPONSIBLE FOR THE REMOVAL OF ALL CONSTRUCTION DEBRIS, DIRT, TRASH, ROCK, SEDIMENT, SOIL, AND SAND THAT MAY ACCUMULATE IN ROADS, STORM DRAINS AND OTHER DRAINAGE CONVEYANCE SYSTEMS AND STORMWATER APPURTENANCES AS A RESULT OF SITE DEVELOPMENT.
- THE QUANTITY OF MATERIALS STORED ON THE PROJECT SITE SHALL BE LIMITED, TO THAT QUANTITY REQUIRED TO PERFORM THE WORK IN AN ORDERLY SEQUENCE. ALL MATERIALS STORED ON-SITE SHALL BE STORED IN A NEAT, ORDERLY MANNER, IN THEIR ORIGINAL CONTAINERS, WITH ORIGINAL MANUFACTURER'S LABELS.
- MATERIALS SHALL NOT BE TEMPORARILY PLACED OR STORED IN THE STREET, ALLEY, OR OTHER PUBLIC WAY, UNLESS IN ACCORDANCE WITH AN APPROVED TRAFFIC CONTROL PLAN. APPROPRIATE CMS SHALL BE UTILIZED BASED ON SPECIFIC CONDITIONS AND CIRCUMSTANCES.
- BULK STORAGE (I.E., INDIVIDUAL CONTAINERS OF 55 GALLONS OR GREATER) OF ALLOWED PETROLEUM PRODUCTS OR OTHER ALLOWED LIQUID SHALL REQUIRE ADEQUATE SECONDARY CONTAINMENT, OR EQUIVALENT PROTECTION, TO CONTAIN ALL SPILLS ON-SITE AND TO PREVENT ANY SPILLED MATERIALS FROM ENTERING STATE WATERS, ANY SURFACE OR SUBSURFACE STORM DRAINAGE SYSTEM, OR OTHER FACILITIES.
- NO CHEMICAL(S) HAVING THE POTENTIAL TO BE RELEASED IN STORMWATER ARE TO BE STORED OR USED ON-SITE UNLESS PERMISSION FOR THE USE OF SUCH CHEMICAL(S) IS GRANTED IN WRITING BY THE EPC ADMINISTRATOR. IN GRANTING APPROVAL FOR THE USE OF SUCH CHEMICAL(S), SPECIAL CONDITIONS AND MONITORING MAY BE REQUIRED.
- ON AREAS OF EXPOSED SOIL, MINIMIZE DUST THROUGH THE APPROPRIATE APPLICATION OF WATER OR OTHER DUST SUPPRESSION TECHNIQUES. WATER APPLICATION MUST BE CONDUCTED IN A MANNER TO PREVENT DISCHARGE OFF-SITE UNLESS AUTHORIZED BY A CDPS OR NATIONAL POLLUTANT DISCHARGE ELIMINATION SYSTEM (NPDES) PERMIT.
- ALL CONSTRUCTION TRAFFIC MUST ENTER/EXIT THE SITE ONLY AT APPROVED CONSTRUCTION ACCESS POINTS.
- FOR SITES WHERE A SOILS REPORT IS REQUIRED, THE APPROVED SOILS REPORT FOR THIS SITE SHALL BE CONSIDERED A PART OF THESE PLANS.
- PERMIT HOLDER(S) AND THEIR AGENTS SHALL COMPLY WITH THE "COLORADO WATER QUALITY CONTROL ACT" (TITLE 25, ARTICLE 8, CRS), AND THE "CLEAN WATER ACT" (33 USC 1344), IN ADDITION TO THE REQUIREMENTS OF THE LAND DEVELOPMENT CODE, DRAINAGE CRITERIA MANUAL VOLUME 2, AND ENGINEERING CRITERIA MANUAL. ALL APPLICABLE LOCAL, STATE, AND FEDERAL PERMITS MUST BE OBTAINED PRIOR TO CONSTRUCTION. IN THE EVENT OF CONFLICTS BETWEEN THESE REQUIREMENTS AND OTHER LAWS, RULES, OR REGULATIONS OF OTHER FEDERAL, STATE, LOCAL, OR COUNTY AGENCIES, THE MOST RESTRICTIVE LAWS, RULES, OR REGULATIONS SHALL APPLY.
- AT LEAST TEN (10) DAYS PRIOR TO THE ANTICIPATED START OF CONSTRUCTION, FOR PROJECTS THAT WILL DISTURB ONE (1) ACRE OR MORE OR LESS THAN 1 ACRE AND PART OF A LARGER COMMON PLAN OF DEVELOPMENT OR SALE THAT WOULD DISTURB 1 OR MORE ACRES, THE PERMIT HOLDER(S) SHALL SUBMIT A PERMIT APPLICATION FOR STORMWATER DISCHARGE (COR400000 PERMIT) TO THE CDPHE WATER QUALITY DIVISION. THE APPLICATION CONTAINS CERTIFICATION OF COMPLETION OF A SWMP, OF WHICH THIS GEC PLAN MAY BE A PART. FOR INFORMATION OR APPLICATION MATERIALS CONTACT:
COLORADO DEPARTMENT OF PUBLIC HEALTH AND ENVIRONMENT
WATER QUALITY CONTROL DIVISION
WQCO - PERMITS
4300 CHERRY CREEK DRIVE SOUTH
DENVER, CO 80246-1530
ATTN: PERMITS UNIT

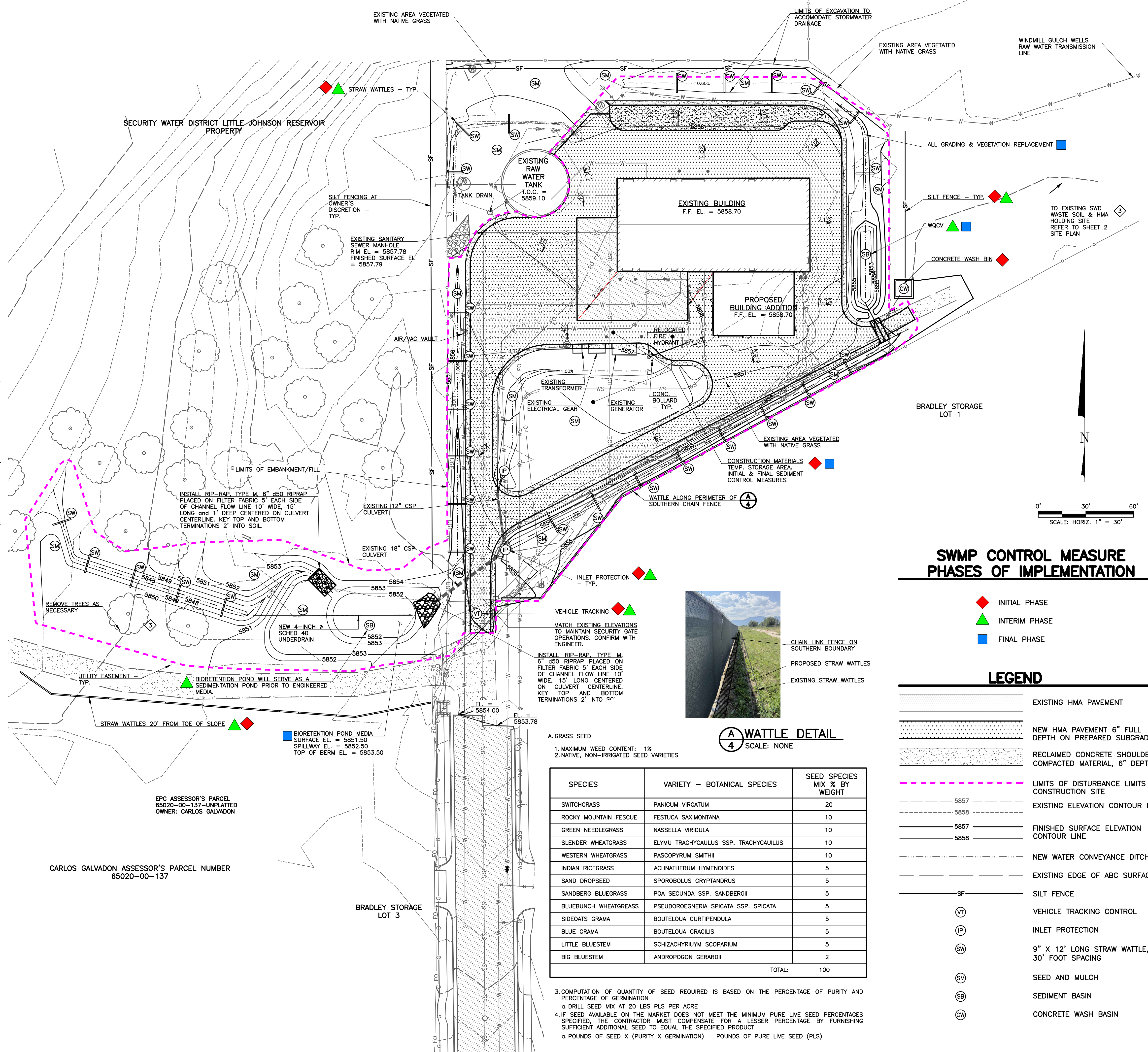

SWMP CONTROL MEASURE PHASES OF IMPLEMENTATION

- ◆ INITIAL PHASE
- ▲ INTERIM PHASE
- FINAL PHASE

LEGEND

- EXISTING HMA PAVEMENT
- NEW HMA PAVEMENT 6" FULL DEPTH ON PREPARED SUBGRADE
- RECLAIMED CONCRETE SHOULDER COMPACTED MATERIAL, 6" DEPTH
- LIMITS OF DISTURBANCE LIMITS OF CONSTRUCTION SITE
- EXISTING ELEVATION CONTOUR LINE
- FINISHED SURFACE ELEVATION CONTOUR LINE
- NEW WATER CONVEYANCE DITCH
- EXISTING EDGE OF ABC SURFACING
- SILT FENCE
- VEHICLE TRACKING CONTROL
- INLET PROTECTION
- 9" X 12" LONG STRAW WATTLE, 30' FOOT SPACING
- SEED AND MULCH
- SEDIMENT BASIN
- CONCRETE WASH BASIN



(A) WATTLE DETAIL
SCALE: NONE

| SPECIES | VARIETY - BOTANICAL SPECIES | SEED SPECIES MIX % BY WEIGHT |
|-----------------------|--------------------------------------|------------------------------|
| SWITCHGRASS | PANICUM VIRGATUM | 20 |
| ROCKY MOUNTAIN FESCUE | FESTUCA SAXIMONTANA | 10 |
| GREEN NEEDLEGRASS | NASSELLA VIRIDULA | 10 |
| SLENDER WHEATGRASS | ELYMU TRACHYCAULUS SSP. TRACHYCAULUS | 10 |
| WESTERN WHEATGRASS | PASPOPYRUM SMITHII | 10 |
| INDIAN RICEGRASS | ACHNATHERUM HYMENOIDES | 5 |
| SAND DROPSEED | SPOROBOLUS CRYPTANDRUS | 5 |
| SANDBERG BLUEGRASS | POA SECUNDA SSP. SANDBERGII | 5 |
| BLUEBUNCH WHEATGRASS | PSEUDOROEGNERIA SPICATA SSP. SPICATA | 5 |
| SIDEOTS GRAMA | BOUTELOUA CURTIPENDULA | 5 |
| BLUE GRAMA | BOUTELOUA GRACILIS | 5 |
| LITTLE BLUESTEM | SCHIZACHRYRIUM SCOPARIUM | 5 |
| BIG BLUESTEM | ANDROPOGON GERARDII | 2 |
| TOTAL: | | 100 |

- COMPUTATION OF QUANTITY OF SEED REQUIRED IS BASED ON THE PERCENTAGE OF PURITY AND PERCENTAGE OF GERMINATION
- DRILL SEED MIX AT 20 LBS PLS PER ACRE
- IF SEED AVAILABLE ON THE MARKET DOES NOT MEET THE MINIMUM PURE LIVE SEED PERCENTAGES SPECIFIED, THE CONTRACTOR MUST COMPENSATE FOR A LESSER PERCENTAGE BY FURNISHING SUFFICIENT ADDITIONAL SEED TO EQUAL THE SPECIFIED PRODUCT
- POUNDS OF SEED X (PURITY X GERMINATION) = POUNDS OF PURE LIVE SEED (PLS)

SCALE VERIFICATION

BAR IS ONE INCH ON ORIGINAL DRAWING
IF NOT ONE INCH ON THIS SHEET ADJUST SCALES ACCORDINGLY
THIS DRAWING IS THE PROPERTY OF GMS, INC., AND IS NOT TO BE REPRODUCED, MODIFIED OR USED FOR ANY PURPOSE WITHOUT THE WRITTEN CONSENT OF THIS PROJECT'S DESIGNER. AGREEMENT WITH THIS COMPANY.
© 2025 GMS, INC.

REVISIONS

| NO. | DATE | DESCRIPTION |
|-----|------------|------------------------------------|
| 1 | 12/31/2024 | ISSUED FOR BIDDING |
| 2 | 9/17/2025 | ADDED BMPs / TSCP |
| 3 | 3/31/2026 | REVISED PER EPCDC NOTES |
| 4 | 5/11/2026 | ADDED BIORETENTION POND PER EPCDC |
| 5 | 6/05/2026 | ADDED GEC PHASES OF IMPLEMENTATION |

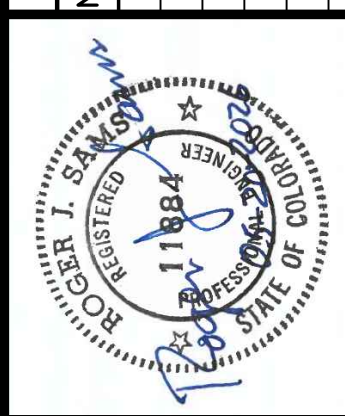

SITE GRADING, DRAINAGE, LANDSCAPING, AND EROSION CONTROL PLAN AND TREATMENT PLANT BUILDING ADDITION
SECURITY WATER DISTRICT

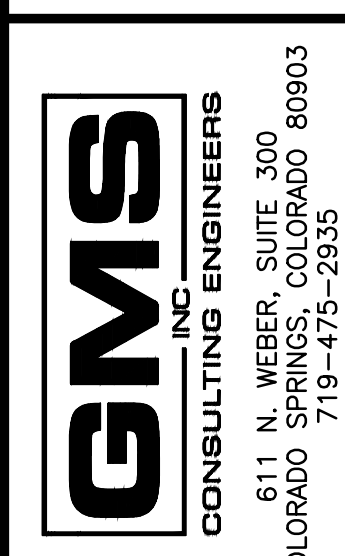

| SK/C | XX | R/S | DATE | PROJECT NO. | GMS FILE NO. |
|-------|----------|---------|------|--------------|--------------|
| DRAWN | DESIGNED | CHECKED | DATE | 2023-053-130 | 3800 |

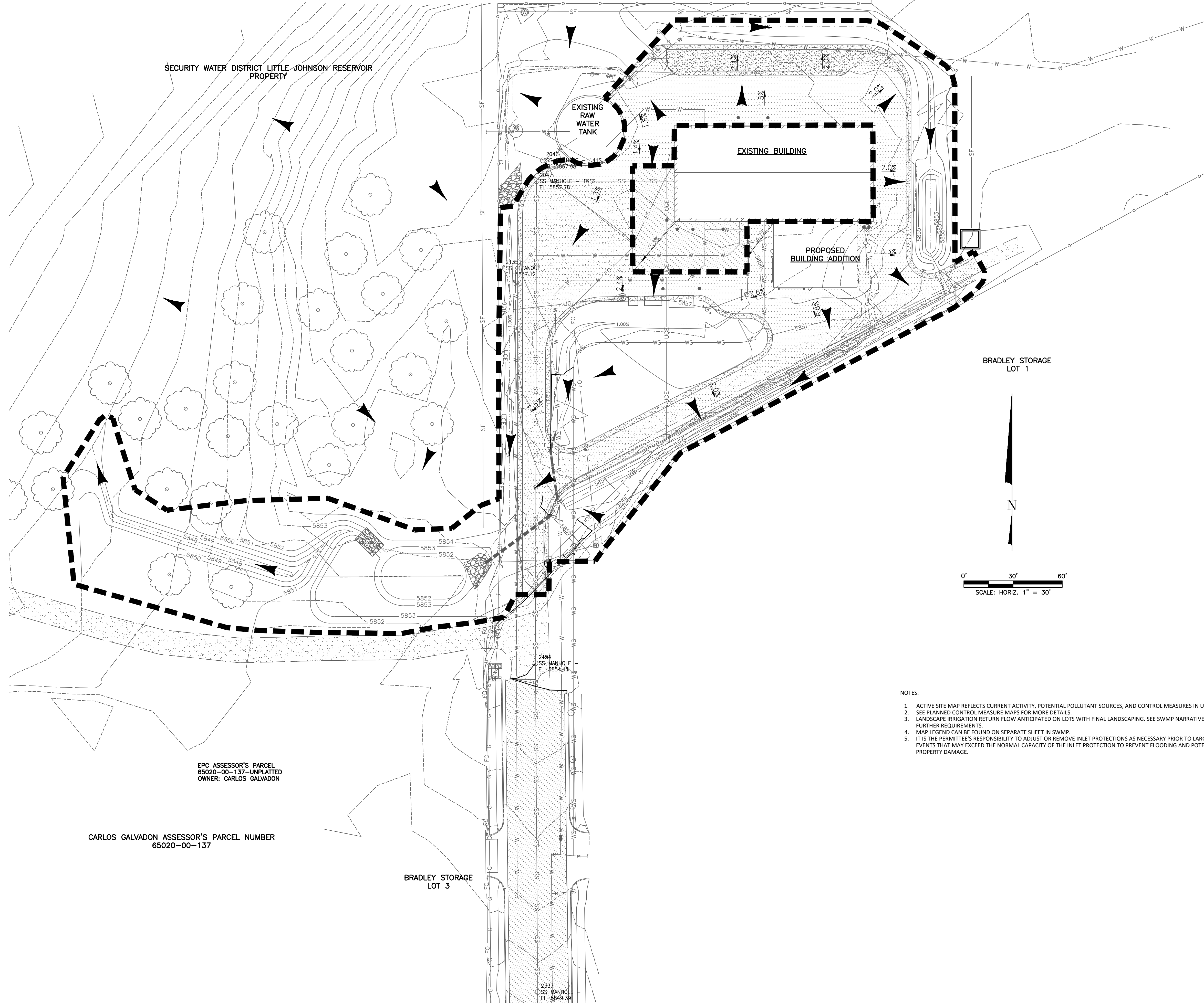

SECURITY WATER DISTRICT LITTLE JOHNSON RESERVOIR PROPERTY

EXISTING RAW WATER TANK

EXISTING BUILDING

PROPOSED BUILDING ADDITION

BRADLEY STORAGE LOT 1

BRADLEY STORAGE LOT 3

EPC ASSESSOR'S PARCEL
65020-00-137-UNPLATTED
OWNER: CARLOS GALVADON

CARLOS GALVADON ASSESSOR'S PARCEL NUMBER
65020-00-137

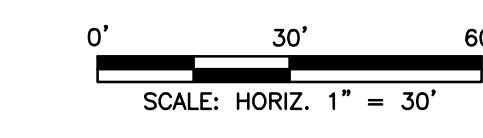

- NOTES:
1. ACTIVE SITE MAP REFLECTS CURRENT ACTIVITY, POTENTIAL POLLUTANT SOURCES, AND CONTROL MEASURES IN USE.
 2. SEE PLANNED CONTROL MEASURE MAPS FOR MORE DETAILS.
 3. LANDSCAPE IRRIGATION RETURN FLOW ANTICIPATED ON LOTS WITH FINAL LANDSCAPING. SEE SWMP NARRATIVE FOR FURTHER REQUIREMENTS.
 4. MAP LEGEND CAN BE FOUND ON SEPARATE SHEET IN SWMP.
 5. IT IS THE PERMITTEE'S RESPONSIBILITY TO ADJUST OR REMOVE INLET PROTECTIONS AS NECESSARY PRIOR TO LARGE RAIN EVENTS THAT MAY EXCEED THE NORMAL CAPACITY OF THE INLET PROTECTION TO PREVENT FLOODING AND POTENTIAL PROPERTY DAMAGE.

SCALE VERIFICATION
BAR IS ONE INCH ON ORIGINAL DRAWING
IF NOT ONE INCH ON THIS SHEET ADJUST SCALES ACCORDINGLY

THIS DRAWING IS THE PROPERTY OF GMS, INC., AND IS NOT TO BE RE-PRODUCED, MODIFIED OR USED FOR ANY PURPOSES WITHOUT THE WRITTEN AGREEMENT WITH THIS COMPANY.
© 2025 GMS, INC.

| NO. | DATE | DESCRIPTION |
|-----|------------|-----------------------------------|
| 1 | 12/31/2024 | ISSUED FOR BIDDING |
| 2 | 9/17/2025 | ADDED BMPs / TSCCP |
| 3 | 3/31/2026 | REVISED PER EPCDD NOTES |
| 4 | 5/11/2026 | ADDED BIORETENTION POND PER EPCDD |

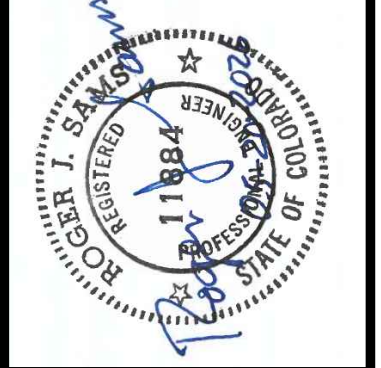

ACTIVE SITE MAP
WATER TREATMENT PLANT BUILDING ADDITION
SECURITY WATER DISTRICT

GMS INC.
CONSULTING ENGINEERS
611 N. WEBER, SUITE 300
COLORADO SPRINGS, COLORADO 80903
719-475-2935

| SKC | DESIGNED | CHECKED | DATE |
|-----|----------|---------|--------------|
| XX | | | |
| R/S | | | |
| | | | OCTOBER 2024 |

PROJECT NO. 2023-053.130
GMS FILE NO. 3800

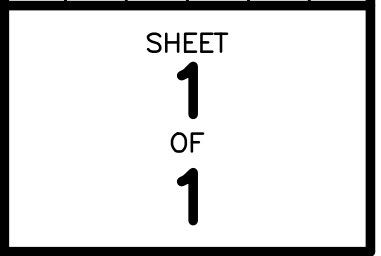

TAB E – SOILS



United States
Department of
Agriculture

NRCS

Natural
Resources
Conservation
Service

A product of the National
Cooperative Soil Survey,
a joint effort of the United
States Department of
Agriculture and other
Federal agencies, State
agencies including the
Agricultural Experiment
Stations, and local
participants

Custom Soil Resource Report for El Paso County Area, Colorado



Preface

Soil surveys contain information that affects land use planning in survey areas. They highlight soil limitations that affect various land uses and provide information about the properties of the soils in the survey areas. Soil surveys are designed for many different users, including farmers, ranchers, foresters, agronomists, urban planners, community officials, engineers, developers, builders, and home buyers. Also, conservationists, teachers, students, and specialists in recreation, waste disposal, and pollution control can use the surveys to help them understand, protect, or enhance the environment.

Various land use regulations of Federal, State, and local governments may impose special restrictions on land use or land treatment. Soil surveys identify soil properties that are used in making various land use or land treatment decisions. The information is intended to help the land users identify and reduce the effects of soil limitations on various land uses. The landowner or user is responsible for identifying and complying with existing laws and regulations.

Although soil survey information can be used for general farm, local, and wider area planning, onsite investigation is needed to supplement this information in some cases. Examples include soil quality assessments (<http://www.nrcs.usda.gov/wps/portal/nrcs/main/soils/health/>) and certain conservation and engineering applications. For more detailed information, contact your local USDA Service Center (<https://offices.sc.egov.usda.gov/locator/app?agency=nrcs>) or your NRCS State Soil Scientist (http://www.nrcs.usda.gov/wps/portal/nrcs/detail/soils/contactus/?cid=nrcs142p2_053951).

Great differences in soil properties can occur within short distances. Some soils are seasonally wet or subject to flooding. Some are too unstable to be used as a foundation for buildings or roads. Clayey or wet soils are poorly suited to use as septic tank absorption fields. A high water table makes a soil poorly suited to basements or underground installations.

The National Cooperative Soil Survey is a joint effort of the United States Department of Agriculture and other Federal agencies, State agencies including the Agricultural Experiment Stations, and local agencies. The Natural Resources Conservation Service (NRCS) has leadership for the Federal part of the National Cooperative Soil Survey.

Information about soils is updated periodically. Updated information is available through the NRCS Web Soil Survey, the site for official soil survey information.

The U.S. Department of Agriculture (USDA) prohibits discrimination in all its programs and activities on the basis of race, color, national origin, age, disability, and where applicable, sex, marital status, familial status, parental status, religion, sexual orientation, genetic information, political beliefs, reprisal, or because all or a part of an individual's income is derived from any public assistance program. (Not all prohibited bases apply to all programs.) Persons with disabilities who require

alternative means for communication of program information (Braille, large print, audiotape, etc.) should contact USDA's TARGET Center at (202) 720-2600 (voice and TDD). To file a complaint of discrimination, write to USDA, Director, Office of Civil Rights, 1400 Independence Avenue, S.W., Washington, D.C. 20250-9410 or call (800) 795-3272 (voice) or (202) 720-6382 (TDD). USDA is an equal opportunity provider and employer.

Contents

| | |
|----------------------------------------------------|----|
| Preface | 2 |
| How Soil Surveys Are Made | 5 |
| Soil Map | 8 |
| Soil Map..... | 9 |
| Legend..... | 10 |
| Map Unit Legend..... | 11 |
| Map Unit Descriptions..... | 11 |
| El Paso County Area, Colorado..... | 13 |
| 8—Blakeland loamy sand, 1 to 9 percent slopes..... | 13 |
| 111—Water..... | 14 |
| Soil Information for All Uses | 15 |
| Soil Properties and Qualities..... | 15 |
| Soil Erosion Factors..... | 15 |
| K Factor, Whole Soil..... | 15 |
| Wind Erodibility Group..... | 19 |
| Soil Reports..... | 24 |
| Soil Erosion..... | 24 |
| RUSLE2 Related Attributes..... | 24 |
| References | 25 |

How Soil Surveys Are Made

Soil surveys are made to provide information about the soils and miscellaneous areas in a specific area. They include a description of the soils and miscellaneous areas and their location on the landscape and tables that show soil properties and limitations affecting various uses. Soil scientists observed the steepness, length, and shape of the slopes; the general pattern of drainage; the kinds of crops and native plants; and the kinds of bedrock. They observed and described many soil profiles. A soil profile is the sequence of natural layers, or horizons, in a soil. The profile extends from the surface down into the unconsolidated material in which the soil formed or from the surface down to bedrock. The unconsolidated material is devoid of roots and other living organisms and has not been changed by other biological activity.

Currently, soils are mapped according to the boundaries of major land resource areas (MLRAs). MLRAs are geographically associated land resource units that share common characteristics related to physiography, geology, climate, water resources, soils, biological resources, and land uses (USDA, 2006). Soil survey areas typically consist of parts of one or more MLRA.

The soils and miscellaneous areas in a survey area occur in an orderly pattern that is related to the geology, landforms, relief, climate, and natural vegetation of the area. Each kind of soil and miscellaneous area is associated with a particular kind of landform or with a segment of the landform. By observing the soils and miscellaneous areas in the survey area and relating their position to specific segments of the landform, a soil scientist develops a concept, or model, of how they were formed. Thus, during mapping, this model enables the soil scientist to predict with a considerable degree of accuracy the kind of soil or miscellaneous area at a specific location on the landscape.

Commonly, individual soils on the landscape merge into one another as their characteristics gradually change. To construct an accurate soil map, however, soil scientists must determine the boundaries between the soils. They can observe only a limited number of soil profiles. Nevertheless, these observations, supplemented by an understanding of the soil-vegetation-landscape relationship, are sufficient to verify predictions of the kinds of soil in an area and to determine the boundaries.

Soil scientists recorded the characteristics of the soil profiles that they studied. They noted soil color, texture, size and shape of soil aggregates, kind and amount of rock fragments, distribution of plant roots, reaction, and other features that enable them to identify soils. After describing the soils in the survey area and determining their properties, the soil scientists assigned the soils to taxonomic classes (units). Taxonomic classes are concepts. Each taxonomic class has a set of soil characteristics with precisely defined limits. The classes are used as a basis for comparison to classify soils systematically. Soil taxonomy, the system of taxonomic classification used in the United States, is based mainly on the kind and character of soil properties and the arrangement of horizons within the profile. After the soil

Custom Soil Resource Report

scientists classified and named the soils in the survey area, they compared the individual soils with similar soils in the same taxonomic class in other areas so that they could confirm data and assemble additional data based on experience and research.

The objective of soil mapping is not to delineate pure map unit components; the objective is to separate the landscape into landforms or landform segments that have similar use and management requirements. Each map unit is defined by a unique combination of soil components and/or miscellaneous areas in predictable proportions. Some components may be highly contrasting to the other components of the map unit. The presence of minor components in a map unit in no way diminishes the usefulness or accuracy of the data. The delineation of such landforms and landform segments on the map provides sufficient information for the development of resource plans. If intensive use of small areas is planned, onsite investigation is needed to define and locate the soils and miscellaneous areas.

Soil scientists make many field observations in the process of producing a soil map. The frequency of observation is dependent upon several factors, including scale of mapping, intensity of mapping, design of map units, complexity of the landscape, and experience of the soil scientist. Observations are made to test and refine the soil-landscape model and predictions and to verify the classification of the soils at specific locations. Once the soil-landscape model is refined, a significantly smaller number of measurements of individual soil properties are made and recorded. These measurements may include field measurements, such as those for color, depth to bedrock, and texture, and laboratory measurements, such as those for content of sand, silt, clay, salt, and other components. Properties of each soil typically vary from one point to another across the landscape.

Observations for map unit components are aggregated to develop ranges of characteristics for the components. The aggregated values are presented. Direct measurements do not exist for every property presented for every map unit component. Values for some properties are estimated from combinations of other properties.

While a soil survey is in progress, samples of some of the soils in the area generally are collected for laboratory analyses and for engineering tests. Soil scientists interpret the data from these analyses and tests as well as the field-observed characteristics and the soil properties to determine the expected behavior of the soils under different uses. Interpretations for all of the soils are field tested through observation of the soils in different uses and under different levels of management. Some interpretations are modified to fit local conditions, and some new interpretations are developed to meet local needs. Data are assembled from other sources, such as research information, production records, and field experience of specialists. For example, data on crop yields under defined levels of management are assembled from farm records and from field or plot experiments on the same kinds of soil.

Predictions about soil behavior are based not only on soil properties but also on such variables as climate and biological activity. Soil conditions are predictable over long periods of time, but they are not predictable from year to year. For example, soil scientists can predict with a fairly high degree of accuracy that a given soil will have a high water table within certain depths in most years, but they cannot predict that a high water table will always be at a specific level in the soil on a specific date.

After soil scientists located and identified the significant natural bodies of soil in the survey area, they drew the boundaries of these bodies on aerial photographs and

Custom Soil Resource Report

identified each as a specific map unit. Aerial photographs show trees, buildings, fields, roads, and rivers, all of which help in locating boundaries accurately.

Soil Map

The soil map section includes the soil map for the defined area of interest, a list of soil map units on the map and extent of each map unit, and cartographic symbols displayed on the map. Also presented are various metadata about data used to produce the map, and a description of each soil map unit.

Custom Soil Resource Report Soil Map



Map Scale: 1:985 if printed on A landscape (11" x 8.5") sheet.

0 10 20 40 60 Meters

0 45 90 180 270 Feet

Map projection: Web Mercator Corner coordinates: WGS84 Edge tics: UTM Zone 13N WGS84

MAP LEGEND

Area of Interest (AOI)

 Area of Interest (AOI)



















Soils







 Soil Map Unit Polygons

 Soil Map Unit Lines

 Soil Map Unit Points

Special Point Features





-  Blowout
-  Borrow Pit
-  Clay Spot
-  Closed Depression
-  Gravel Pit
-  Gravelly Spot
-  Landfill
-  Lava Flow
-  Marsh or swamp
-  Mine or Quarry
-  Miscellaneous Water
-  Perennial Water
-  Rock Outcrop
-  Saline Spot
-  Sandy Spot
-  Severely Eroded Spot
-  Sinkhole
-  Slide or Slip
-  Sodic Spot

-  Spoil Area
-  Stony Spot
-  Very Stony Spot
-  Wet Spot
-  Other
-  Special Line Features

Water Features

 Streams and Canals

Transportation

-  Rails
-  Interstate Highways
-  US Routes
-  Major Roads
-  Local Roads

Background

 Aerial Photography

MAP INFORMATION

The soil surveys that comprise your AOI were mapped at 1:24,000.

Warning: Soil Map may not be valid at this scale.

Enlargement of maps beyond the scale of mapping can cause misunderstanding of the detail of mapping and accuracy of soil line placement. The maps do not show the small areas of contrasting soils that could have been shown at a more detailed scale.

Please rely on the bar scale on each map sheet for map measurements.

Source of Map: Natural Resources Conservation Service
 Web Soil Survey URL:
 Coordinate System: Web Mercator (EPSG:3857)

Maps from the Web Soil Survey are based on the Web Mercator projection, which preserves direction and shape but distorts distance and area. A projection that preserves area, such as the Albers equal-area conic projection, should be used if more accurate calculations of distance or area are required.

This product is generated from the USDA-NRCS certified data as of the version date(s) listed below.

Soil Survey Area: El Paso County Area, Colorado
 Survey Area Data: Version 23, Aug 29, 2025

Soil map units are labeled (as space allows) for map scales 1:50,000 or larger.

Date(s) aerial images were photographed: Jul 23, 2024—Aug 4, 2024

The orthophoto or other base map on which the soil lines were compiled and digitized probably differs from the background imagery displayed on these maps. As a result, some minor shifting of map unit boundaries may be evident.

Map Unit Legend

| Map Unit Symbol | Map Unit Name | Acres in AOI | Percent of AOI |
|------------------------------------|---------------------------------------------|--------------|----------------|
| 8 | Blakeland loamy sand, 1 to 9 percent slopes | 1.6 | 82.5% |
| 111 | Water | 0.3 | 17.5% |
| Totals for Area of Interest | | 1.9 | 100.0% |

Map Unit Descriptions

The map units delineated on the detailed soil maps in a soil survey represent the soils or miscellaneous areas in the survey area. The map unit descriptions, along with the maps, can be used to determine the composition and properties of a unit.

A map unit delineation on a soil map represents an area dominated by one or more major kinds of soil or miscellaneous areas. A map unit is identified and named according to the taxonomic classification of the dominant soils. Within a taxonomic class there are precisely defined limits for the properties of the soils. On the landscape, however, the soils are natural phenomena, and they have the characteristic variability of all natural phenomena. Thus, the range of some observed properties may extend beyond the limits defined for a taxonomic class. Areas of soils of a single taxonomic class rarely, if ever, can be mapped without including areas of other taxonomic classes. Consequently, every map unit is made up of the soils or miscellaneous areas for which it is named and some minor components that belong to taxonomic classes other than those of the major soils.

Most minor soils have properties similar to those of the dominant soil or soils in the map unit, and thus they do not affect use and management. These are called noncontrasting, or similar, components. They may or may not be mentioned in a particular map unit description. Other minor components, however, have properties and behavioral characteristics divergent enough to affect use or to require different management. These are called contrasting, or dissimilar, components. They generally are in small areas and could not be mapped separately because of the scale used. Some small areas of strongly contrasting soils or miscellaneous areas are identified by a special symbol on the maps. If included in the database for a given area, the contrasting minor components are identified in the map unit descriptions along with some characteristics of each. A few areas of minor components may not have been observed, and consequently they are not mentioned in the descriptions, especially where the pattern was so complex that it was impractical to make enough observations to identify all the soils and miscellaneous areas on the landscape.

The presence of minor components in a map unit in no way diminishes the usefulness or accuracy of the data. The objective of mapping is not to delineate pure taxonomic classes but rather to separate the landscape into landforms or landform segments that have similar use and management requirements. The delineation of such segments on the map provides sufficient information for the development of resource plans. If intensive use of small areas is planned, however,

Custom Soil Resource Report

onsite investigation is needed to define and locate the soils and miscellaneous areas.

An identifying symbol precedes the map unit name in the map unit descriptions. Each description includes general facts about the unit and gives important soil properties and qualities.

Soils that have profiles that are almost alike make up a *soil series*. Except for differences in texture of the surface layer, all the soils of a series have major horizons that are similar in composition, thickness, and arrangement.

Soils of one series can differ in texture of the surface layer, slope, stoniness, salinity, degree of erosion, and other characteristics that affect their use. On the basis of such differences, a soil series is divided into *soil phases*. Most of the areas shown on the detailed soil maps are phases of soil series. The name of a soil phase commonly indicates a feature that affects use or management. For example, Alpha silt loam, 0 to 2 percent slopes, is a phase of the Alpha series.

Some map units are made up of two or more major soils or miscellaneous areas. These map units are complexes, associations, or undifferentiated groups.

A *complex* consists of two or more soils or miscellaneous areas in such an intricate pattern or in such small areas that they cannot be shown separately on the maps. The pattern and proportion of the soils or miscellaneous areas are somewhat similar in all areas. Alpha-Beta complex, 0 to 6 percent slopes, is an example.

An *association* is made up of two or more geographically associated soils or miscellaneous areas that are shown as one unit on the maps. Because of present or anticipated uses of the map units in the survey area, it was not considered practical or necessary to map the soils or miscellaneous areas separately. The pattern and relative proportion of the soils or miscellaneous areas are somewhat similar. Alpha-Beta association, 0 to 2 percent slopes, is an example.

An *undifferentiated group* is made up of two or more soils or miscellaneous areas that could be mapped individually but are mapped as one unit because similar interpretations can be made for use and management. The pattern and proportion of the soils or miscellaneous areas in a mapped area are not uniform. An area can be made up of only one of the major soils or miscellaneous areas, or it can be made up of all of them. Alpha and Beta soils, 0 to 2 percent slopes, is an example.

Some surveys include *miscellaneous areas*. Such areas have little or no soil material and support little or no vegetation. Rock outcrop is an example.

El Paso County Area, Colorado

8—Blakeland loamy sand, 1 to 9 percent slopes

Map Unit Setting

National map unit symbol: 369v
Landscape: Uplands
Elevation: 4,600 to 5,800 feet
Mean annual precipitation: 14 to 16 inches
Mean annual air temperature: 46 to 48 degrees F
Frost-free period: 125 to 145 days
Farmland classification: Not prime farmland

Map Unit Composition

Blakeland and similar soils: 98 percent
Minor components: 2 percent
Estimates are based on observations, descriptions, and transects of the mapunit.

Description of Blakeland

Setting

Landscape: Uplands
Landform: Flats, Hills
Landform position (three-dimensional): Side slope, talf
Down-slope shape: Linear
Across-slope shape: Linear
Parent material: Alluvium derived from sedimentary rock and/or eolian deposits derived from sedimentary rock

Typical profile

A - 0 to 11 inches: loamy sand
AC - 11 to 27 inches: loamy sand
C - 27 to 60 inches: sand

Properties and qualities

Slope: 1 to 9 percent
Depth to restrictive feature: More than 80 inches
Drainage class: Somewhat excessively drained
Runoff class: Low
Capacity of the most limiting layer to transmit water (Ksat): High to very high (5.95 to 19.98 in/hr)
Depth to water table: More than 80 inches
Frequency of flooding: None
Frequency of ponding: None
Calcium carbonate, maximum content: 5 percent
Available water supply, 0 to 60 inches: Low (about 4.5 inches)

Interpretive groups

Land capability classification (irrigated): 3e
Land capability classification (nonirrigated): 6e
Hydrologic Soil Group: A
Ecological site: R049XB210CO - Sandy Foothill
Hydric soil rating: No

Minor Components

Other soils

Percent of map unit: 1 percent
Hydric soil rating: No

Pleasant

Percent of map unit: 1 percent
Landform: Depressions
Hydric soil rating: Yes

111—Water

Map Unit Composition

Water: 100 percent
Estimates are based on observations, descriptions, and transects of the mapunit.

Soil Information for All Uses

Soil Properties and Qualities

The Soil Properties and Qualities section includes various soil properties and qualities displayed as thematic maps with a summary table for the soil map units in the selected area of interest. A single value or rating for each map unit is generated by aggregating the interpretive ratings of individual map unit components. This aggregation process is defined for each property or quality.

Soil Erosion Factors

Soil Erosion Factors are soil properties and interpretations used in evaluating the soil for potential erosion. Example soil erosion factors can include K factor for the whole soil or on a rock free basis, T factor, wind erodibility group and wind erodibility index.

K Factor, Whole Soil

Erosion factor K indicates the susceptibility of a soil to sheet and rill erosion by water. Factor K is one of six factors used in the Universal Soil Loss Equation (USLE) and the Revised Universal Soil Loss Equation (RUSLE) to predict the average annual rate of soil loss by sheet and rill erosion in tons per acre per year. The estimates are based primarily on percentage of silt, sand, and organic matter and on soil structure and saturated hydraulic conductivity (Ksat). Values of K range from 0.02 to 0.69. Other factors being equal, the higher the value, the more susceptible the soil is to sheet and rill erosion by water.

"Erosion factor Kw (whole soil)" indicates the erodibility of the whole soil. The estimates are modified by the presence of rock fragments.

Factor K does not apply to organic horizons and is not reported for those layers.

Custom Soil Resource Report
Map—K Factor, Whole Soil

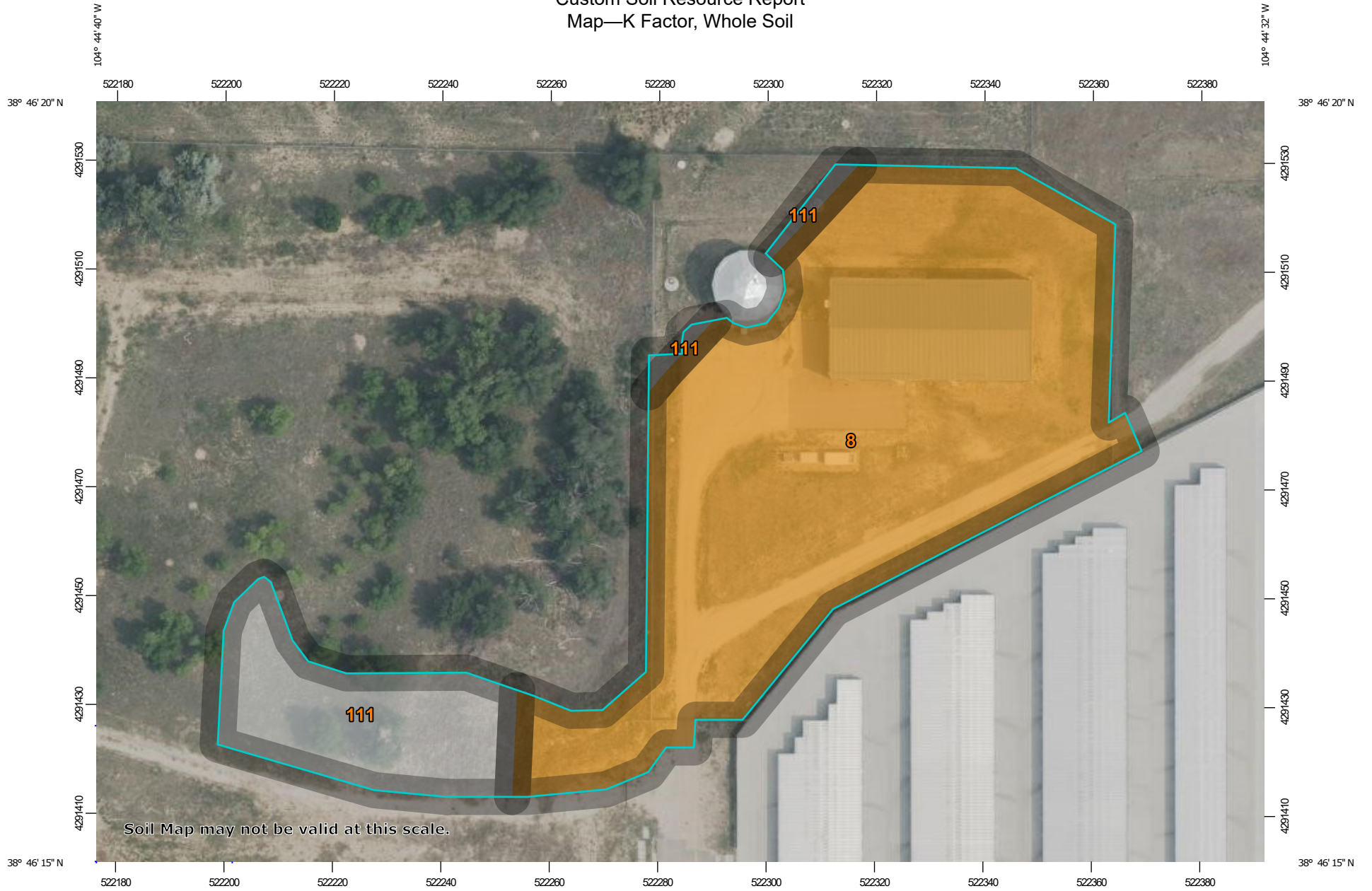

Map Scale: 1:985 if printed on A landscape (11" x 8.5") sheet.



Map projection: Web Mercator Corner coordinates: WGS84 Edge tics: UTM Zone 13N WGS84

















MAP LEGEND

Area of Interest (AOI)







 Area of Interest (AOI)









Soils

Soil Rating Polygons













-  .02
-  .05
-  .10
-  .15
-  .17
-  .20
-  .24
-  .28
-  .32
-  .37
-  .43
-  .49
-  .55
-  .64
-  Not rated or not available

Soil Rating Lines







-  .02
-  .05
-  .10
-  .15
-  .17
-  .20

-  .24
-  .28
-  .32
-  .37
-  .43
-  .49
-  .55
-  .64
-  Not rated or not available

Soil Rating Points

-  .02
-  .05
-  .10
-  .15
-  .17
-  .20
-  .24
-  .28
-  .32
-  .37
-  .43
-  .49
-  .55
-  .64
-  Not rated or not available

Water Features

-  Streams and Canals
- Transportation**
-  Rails
-  Interstate Highways
-  US Routes
-  Major Roads
-  Local Roads
- Background**
-  Aerial Photography

MAP INFORMATION

The soil surveys that comprise your AOI were mapped at 1:24,000.

Warning: Soil Map may not be valid at this scale.

Enlargement of maps beyond the scale of mapping can cause misunderstanding of the detail of mapping and accuracy of soil line placement. The maps do not show the small areas of contrasting soils that could have been shown at a more detailed scale.

Please rely on the bar scale on each map sheet for map measurements.

Source of Map: Natural Resources Conservation Service
 Web Soil Survey URL:
 Coordinate System: Web Mercator (EPSG:3857)

Maps from the Web Soil Survey are based on the Web Mercator projection, which preserves direction and shape but distorts distance and area. A projection that preserves area, such as the Albers equal-area conic projection, should be used if more accurate calculations of distance or area are required.

This product is generated from the USDA-NRCS certified data as of the version date(s) listed below.

Soil Survey Area: El Paso County Area, Colorado
 Survey Area Data: Version 23, Aug 29, 2025

Soil map units are labeled (as space allows) for map scales 1:50,000 or larger.

Date(s) aerial images were photographed: Jul 23, 2024—Aug 4, 2024

The orthophoto or other base map on which the soil lines were compiled and digitized probably differs from the background imagery displayed on these maps. As a result, some minor shifting of map unit boundaries may be evident.

Table—K Factor, Whole Soil

| Map unit symbol | Map unit name | Rating | Acres in AOI | Percent of AOI |
|------------------------------------|---------------------------------------------|--------|--------------|----------------|
| 8 | Blakeland loamy sand, 1 to 9 percent slopes | .10 | 1.6 | 82.5% |
| 111 | Water | | 0.3 | 17.5% |
| Totals for Area of Interest | | | 1.9 | 100.0% |

Rating Options—K Factor, Whole Soil

Aggregation Method: Dominant Condition

Aggregation is the process by which a set of component attribute values is reduced to a single value that represents the map unit as a whole.

A map unit is typically composed of one or more "components". A component is either some type of soil or some nonsoil entity, e.g., rock outcrop. For the attribute being aggregated, the first step of the aggregation process is to derive one attribute value for each of a map unit's components. From this set of component attributes, the next step of the aggregation process derives a single value that represents the map unit as a whole. Once a single value for each map unit is derived, a thematic map for soil map units can be rendered. Aggregation must be done because, on any soil map, map units are delineated but components are not.

For each of a map unit's components, a corresponding percent composition is recorded. A percent composition of 60 indicates that the corresponding component typically makes up approximately 60% of the map unit. Percent composition is a critical factor in some, but not all, aggregation methods.

The aggregation method "Dominant Condition" first groups like attribute values for the components in a map unit. For each group, percent composition is set to the sum of the percent composition of all components participating in that group. These groups now represent "conditions" rather than components. The attribute value associated with the group with the highest cumulative percent composition is returned. If more than one group shares the highest cumulative percent composition, the corresponding "tie-break" rule determines which value should be returned. The "tie-break" rule indicates whether the lower or higher group value should be returned in the case of a percent composition tie. The result returned by this aggregation method represents the dominant condition throughout the map unit only when no tie has occurred.

Component Percent Cutoff: None Specified

Components whose percent composition is below the cutoff value will not be considered. If no cutoff value is specified, all components in the database will be considered. The data for some contrasting soils of minor extent may not be in the database, and therefore are not considered.

Tie-break Rule: Higher

Custom Soil Resource Report

The tie-break rule indicates which value should be selected from a set of multiple candidate values, or which value should be selected in the event of a percent composition tie.

Layer Options (Horizon Aggregation Method): Surface Layer (Not applicable)

For an attribute of a soil horizon, a depth qualification must be specified. In most cases it is probably most appropriate to specify a fixed depth range, either in centimeters or inches. The Bottom Depth must be greater than the Top Depth, and the Top Depth can be greater than zero. The choice of "inches" or "centimeters" only applies to the depth of soil to be evaluated. It has no influence on the units of measure the data are presented in.

When "Surface Layer" is specified as the depth qualifier, only the surface layer or horizon is considered when deriving a value for a component, but keep in mind that the thickness of the surface layer varies from component to component.

When "All Layers" is specified as the depth qualifier, all layers recorded for a component are considered when deriving the value for that component.

Whenever more than one layer or horizon is considered when deriving a value for a component, and the attribute being aggregated is a numeric attribute, a weighted average value is returned, where the weighting factor is the layer or horizon thickness.

Wind Erodibility Group

Custom Soil Resource Report Map—Wind Erodibility Group

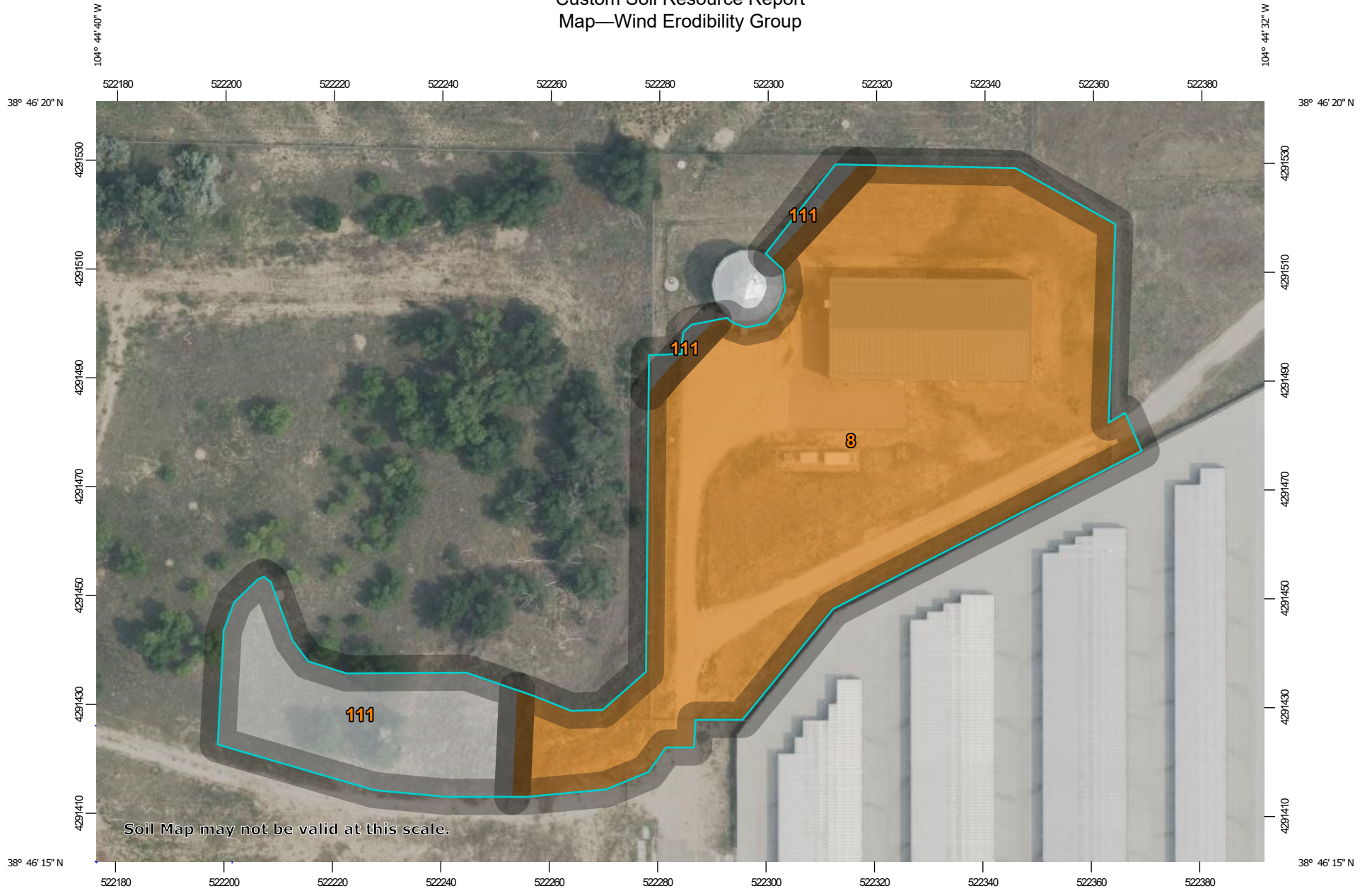

Map Scale: 1:985 if printed on A landscape (11" x 8.5") sheet.

0 10 20 40 60 Meters

0 45 90 180 270 Feet











Map projection: Web Mercator Corner coordinates: WGS84 Edge tics: UTM Zone 13N WGS84

MAP LEGEND











Area of Interest (AOI)
 Area of Interest (AOI)

Soils











Soil Rating Polygons

| | |
|-----------------------------------------------------------------------------------|----------------------------|
|  | 1 |
|  | 2 |
|  | 3 |
|  | 4 |
|  | 4L |
|  | 5 |
|  | 6 |
|  | 7 |
|  | 8 |
|  | Not rated or not available |

Soil Rating Lines

| | |
|-------------------------------------------------------------------------------------|----------------------------|
|  | 1 |
|  | 2 |
|  | 3 |
|  | 4 |
|  | 4L |
|  | 5 |
|  | 6 |
|  | 7 |
|  | 8 |
|  | Not rated or not available |





Soil Rating Points

| | |
|-----------------------------------------------------------------------------------|----------------------------|
|  | 1 |
|  | 2 |
|  | 3 |
|  | 4 |
|  | 4L |
|  | 5 |
|  | 6 |
|  | 7 |
|  | 8 |
|  | Not rated or not available |

Water Features

| | |
|-----------------------------------------------------------------------------------|--------------------|
|  | Streams and Canals |
|-----------------------------------------------------------------------------------|--------------------|

Transportation

| | |
|-----------------------------------------------------------------------------------|---------------------|
|  | Rails |
|  | Interstate Highways |
|  | US Routes |
|  | Major Roads |
|  | Local Roads |

Background

| | |
|-------------------------------------------------------------------------------------|--------------------|
|  | Aerial Photography |
|-------------------------------------------------------------------------------------|--------------------|

MAP INFORMATION

The soil surveys that comprise your AOI were mapped at 1:24,000.

Warning: Soil Map may not be valid at this scale.

Enlargement of maps beyond the scale of mapping can cause misunderstanding of the detail of mapping and accuracy of soil line placement. The maps do not show the small areas of contrasting soils that could have been shown at a more detailed scale.

Please rely on the bar scale on each map sheet for map measurements.

Source of Map: Natural Resources Conservation Service
 Web Soil Survey URL:
 Coordinate System: Web Mercator (EPSG:3857)

Maps from the Web Soil Survey are based on the Web Mercator projection, which preserves direction and shape but distorts distance and area. A projection that preserves area, such as the Albers equal-area conic projection, should be used if more accurate calculations of distance or area are required.

This product is generated from the USDA-NRCS certified data as of the version date(s) listed below.

Soil Survey Area: El Paso County Area, Colorado
 Survey Area Data: Version 23, Aug 29, 2025

Soil map units are labeled (as space allows) for map scales 1:50,000 or larger.

Date(s) aerial images were photographed: Jul 23, 2024—Aug 4, 2024

The orthophoto or other base map on which the soil lines were compiled and digitized probably differs from the background imagery displayed on these maps. As a result, some minor shifting of map unit boundaries may be evident.

Table—Wind Erodibility Group

| Map unit symbol | Map unit name | Rating | Acres in AOI | Percent of AOI |
|------------------------------------|---------------------------------------------|--------|--------------|----------------|
| 8 | Blakeland loamy sand, 1 to 9 percent slopes | 2 | 1.6 | 82.5% |
| 111 | Water | | 0.3 | 17.5% |
| Totals for Area of Interest | | | 1.9 | 100.0% |

Rating Options—Wind Erodibility Group

Aggregation Method: Dominant Condition

Aggregation is the process by which a set of component attribute values is reduced to a single value that represents the map unit as a whole.

A map unit is typically composed of one or more "components". A component is either some type of soil or some nonsoil entity, e.g., rock outcrop. For the attribute being aggregated, the first step of the aggregation process is to derive one attribute value for each of a map unit's components. From this set of component attributes, the next step of the aggregation process derives a single value that represents the map unit as a whole. Once a single value for each map unit is derived, a thematic map for soil map units can be rendered. Aggregation must be done because, on any soil map, map units are delineated but components are not.

For each of a map unit's components, a corresponding percent composition is recorded. A percent composition of 60 indicates that the corresponding component typically makes up approximately 60% of the map unit. Percent composition is a critical factor in some, but not all, aggregation methods.

The aggregation method "Dominant Condition" first groups like attribute values for the components in a map unit. For each group, percent composition is set to the sum of the percent composition of all components participating in that group. These groups now represent "conditions" rather than components. The attribute value associated with the group with the highest cumulative percent composition is returned. If more than one group shares the highest cumulative percent composition, the corresponding "tie-break" rule determines which value should be returned. The "tie-break" rule indicates whether the lower or higher group value should be returned in the case of a percent composition tie. The result returned by this aggregation method represents the dominant condition throughout the map unit only when no tie has occurred.

Component Percent Cutoff: None Specified

Components whose percent composition is below the cutoff value will not be considered. If no cutoff value is specified, all components in the database will be considered. The data for some contrasting soils of minor extent may not be in the database, and therefore are not considered.

Tie-break Rule: Lower

Custom Soil Resource Report

The tie-break rule indicates which value should be selected from a set of multiple candidate values, or which value should be selected in the event of a percent composition tie.

Soil Reports

The Soil Reports section includes various formatted tabular and narrative reports (tables) containing data for each selected soil map unit and each component of each unit. No aggregation of data has occurred as is done in reports in the Soil Properties and Qualities and Suitabilities and Limitations sections.

The reports contain soil interpretive information as well as basic soil properties and qualities. A description of each report (table) is included.

Soil Erosion

This folder contains a collection of tabular reports that present soil erosion factors and groupings. The reports (tables) include all selected map units and components for each map unit. Soil erosion factors are soil properties and interpretations used in evaluating the soil for potential erosion. Example soil erosion factors can include K factor for the whole soil or on a rock free basis, T factor, wind erodibility group and wind erodibility index.

RUSLE2 Related Attributes

This report summarizes those soil attributes used by the Revised Universal Soil Loss Equation Version 2 (RUSLE2) for the map units in the selected area. The report includes the map unit symbol, the component name, and the percent of the component in the map unit. Soil property data for each map unit component include the hydrologic soil group, erosion factor Kf for the surface horizon, erosion factor T, and the representative percentage of sand, silt, and clay in the mineral surface horizon. Missing surface data may indicate the presence of an organic layer.

Report—RUSLE2 Related Attributes

Soil properties and interpretations for erosion runoff calculations. The surface mineral horizon properties are displayed or the first mineral horizon below an organic surface horizon. Organic horizons are not displayed.

| RUSLE2 Related Attributes—El Paso County Area, Colorado | | | | | | | | |
|---------------------------------------------------------|------------------|-------------------|------------------|-----|----------|----------------------|--------|--------|
| Map symbol and soil name | Pct. of map unit | Slope length (ft) | Hydrologic group | Kf | T factor | Representative value | | |
| | | | | | | % Sand | % Silt | % Clay |
| 8—Blakeland loamy sand, 1 to 9 percent slopes | | | | | | | | |
| Blakeland | 98 | — | A | .10 | 5 | 85.3 | 9.2 | 5.5 |

References

- American Association of State Highway and Transportation Officials (AASHTO). 2004. Standard specifications for transportation materials and methods of sampling and testing. 24th edition.
- American Society for Testing and Materials (ASTM). 2005. Standard classification of soils for engineering purposes. ASTM Standard D2487-00.
- Cowardin, L.M., V. Carter, F.C. Golet, and E.T. LaRoe. 1979. Classification of wetlands and deep-water habitats of the United States. U.S. Fish and Wildlife Service FWS/OBS-79/31.
- Federal Register. July 13, 1994. Changes in hydric soils of the United States.
- Federal Register. September 18, 2002. Hydric soils of the United States.
- Hurt, G.W., and L.M. Vasilas, editors. Version 6.0, 2006. Field indicators of hydric soils in the United States.
- National Research Council. 1995. Wetlands: Characteristics and boundaries.
- Soil Survey Division Staff. 1993. Soil survey manual. Soil Conservation Service. U.S. Department of Agriculture Handbook 18. http://www.nrcs.usda.gov/wps/portal/nrcs/detail/national/soils/?cid=nrcs142p2_054262
- Soil Survey Staff. 1999. Soil taxonomy: A basic system of soil classification for making and interpreting soil surveys. 2nd edition. Natural Resources Conservation Service, U.S. Department of Agriculture Handbook 436. http://www.nrcs.usda.gov/wps/portal/nrcs/detail/national/soils/?cid=nrcs142p2_053577
- Soil Survey Staff. 2010. Keys to soil taxonomy. 11th edition. U.S. Department of Agriculture, Natural Resources Conservation Service. http://www.nrcs.usda.gov/wps/portal/nrcs/detail/national/soils/?cid=nrcs142p2_053580
- Tiner, R.W., Jr. 1985. Wetlands of Delaware. U.S. Fish and Wildlife Service and Delaware Department of Natural Resources and Environmental Control, Wetlands Section.
- United States Army Corps of Engineers, Environmental Laboratory. 1987. Corps of Engineers wetlands delineation manual. Waterways Experiment Station Technical Report Y-87-1.
- United States Department of Agriculture, Natural Resources Conservation Service. National forestry manual. http://www.nrcs.usda.gov/wps/portal/nrcs/detail/soils/home/?cid=nrcs142p2_053374
- United States Department of Agriculture, Natural Resources Conservation Service. National range and pasture handbook. <http://www.nrcs.usda.gov/wps/portal/nrcs/detail/national/landuse/rangepasture/?cid=stelprdb1043084>

Custom Soil Resource Report

United States Department of Agriculture, Natural Resources Conservation Service. National soil survey handbook, title 430-VI. http://www.nrcs.usda.gov/wps/portal/nrcs/detail/soils/scientists/?cid=nrcs142p2_054242

United States Department of Agriculture, Natural Resources Conservation Service. 2006. Land resource regions and major land resource areas of the United States, the Caribbean, and the Pacific Basin. U.S. Department of Agriculture Handbook 296. http://www.nrcs.usda.gov/wps/portal/nrcs/detail/national/soils/?cid=nrcs142p2_053624

United States Department of Agriculture, Soil Conservation Service. 1961. Land capability classification. U.S. Department of Agriculture Handbook 210. http://www.nrcs.usda.gov/Internet/FSE_DOCUMENTS/nrcs142p2_052290.pdf

TAB F – GRADING AND EROSION CONTROL PLAN

GRADING AND EROSION CONTROL PLAN

FOR

SECURITY WATER DISTRICT

WATER TREATMENT PLANT BUILDING ADDITION

AUGUST 2024 (AMENDED JANUARY 2026)

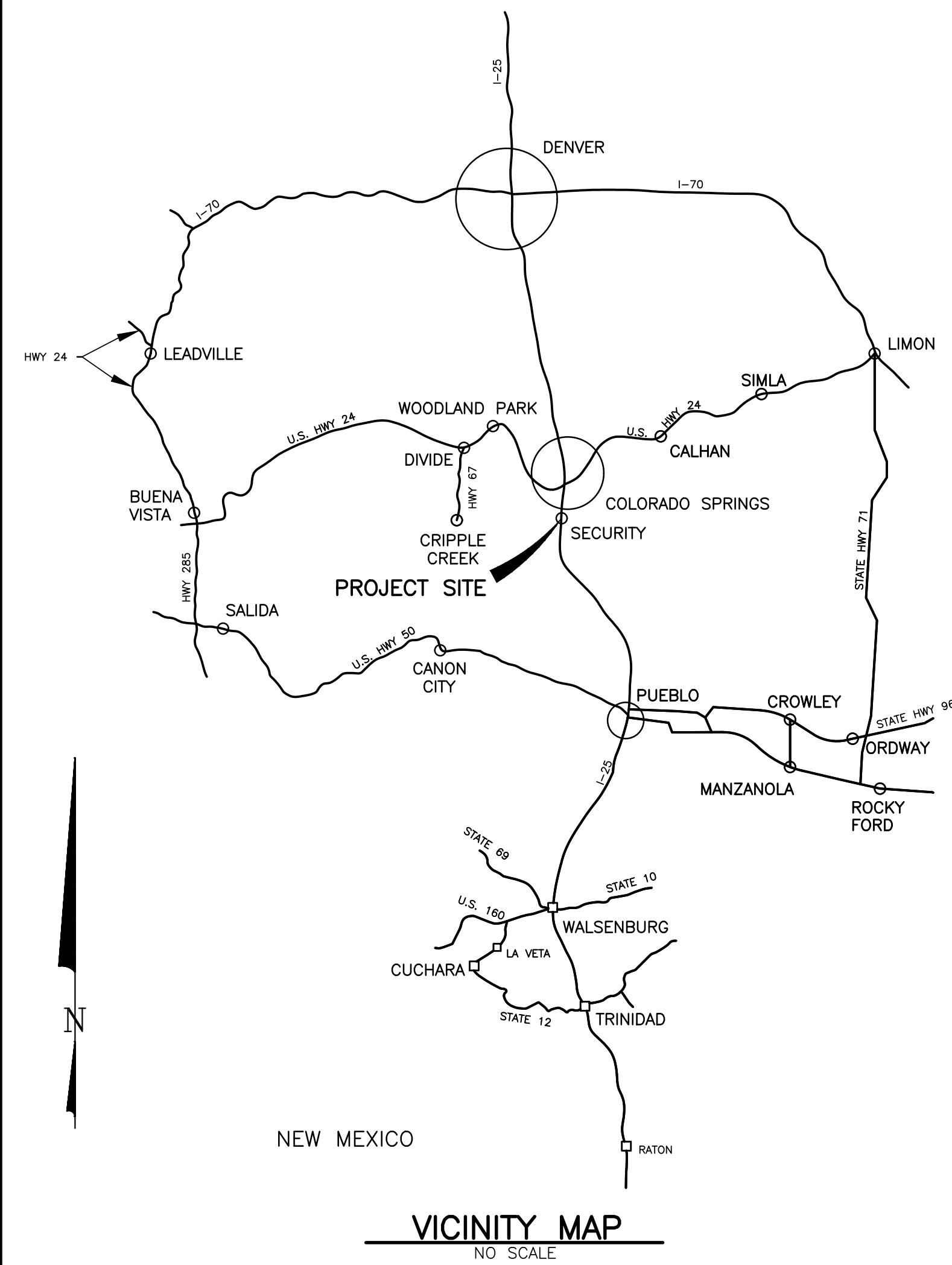

DRAWING INDEX

| SHEET NO. | DESCRIPTION |
|-----------|-----------------------------------------------|
| 1 | TITLE SHEET, VICINITY MAPS, AND DRAWING INDEX |
| 2 | SWD PROPERTY SITE PLAN |
| 3 | BUILDING SITE PLAN |
| 4 | LANDSCAPE PLAN |

ENGINEER'S STATEMENT:

THIS GRADING AND EROSION CONTROL PLAN WAS PREPARED UNDER MY DIRECTION AND SUPERVISION AND IS CORRECT TO THE BEST OF MY KNOWLEDGE AND BELIEF. SAID PLAN HAS BEEN PREPARED ACCORDING TO THE CRITERIA ESTABLISHED BY THE COUNTY FOR GRADING AND EROSION CONTROL PLANS. I ACCEPT RESPONSIBILITY FOR ANY LIABILITY CAUSED BY ANY NEGLIGENT ACTS, ERRORS OR OMISSIONS ON MY PART IN PREPARING THIS PLAN.

Roger J. Sams
ROGER J. SAM'S, P.E. NO. 11884
GMS CONSULTING ENGINEERS, INC.

05/20/2026
DATE



OWNER'S STATEMENT:

I, THE OWNER/DEVELOPER, HAVE READ AND WILL COMPLY WITH THE REQUIREMENTS OF THE GRADING AND EROSION CONTROL PLAN.

Roy E. Heald
SECURITY WATER DISTRICT
ROY E. HEALD, GENERAL MANAGER
231 SECURITY BLVD.
COLORADO SPRINGS CO 80911

05/20/2026
DATE

EL PASO COUNTY:

COUNTY PLAN REVIEW IS PROVIDED ONLY FOR GENERAL CONFORMANCE WITH COUNTY DESIGN CRITERIA. THE COUNTY IS NOT RESPONSIBLE FOR THE ACCURACY AND ADEQUACY OF THE DESIGN, DIMENSIONS, AND/OR ELEVATIONS WHICH SHALL BE CONFIRMED AT THE JOB SITE. THE COUNTY THROUGH THE APPROVAL OF THIS DOCUMENT ASSUMES NO RESPONSIBILITY FOR COMPLETENESS AND/ OR ACCURACY OF THIS DOCUMENT.

FILED IN ACCORDANCE WITH THE REQUIREMENTS OF THE EL PASO COUNTY LAND DEVELOPMENT CODE, DRAINAGE CRITERIA MANUAL VOLUMES 1 AND 2, AND ENGINEERING CRITERIA MANUAL, AS AMENDED.

IN ACCORDANCE WITH ECM SECTION 1.12, THESE CONSTRUCTION DOCUMENTS WILL BE VALID FOR CONSTRUCTION FOR A PERIOD OF 2 YEARS FROM THE DATE SIGNED BY THE EL PASO COUNTY ENGINEER. IF CONSTRUCTION HAS NOT STARTED WITHIN THOSE 2 YEARS, THE PLANS WILL NEED TO BE RESUBMITTED FOR APPROVAL, INCLUDING PAYMENT OF REVIEW FEES AT THE PLANNING AND COMMUNITY DEVELOPMENT DIRECTOR'S DISCRETION.

JOSHUA J. PALMER, P.E.
COUNTY ENGINEER/ ECM ADMINISTRATOR

DATE

GMS, INC.
611 NORTH WEBER, SUITE 300
COLORADO SPRINGS, COLORADO 80903

2024 GMS, INC.

SHEET 1 OF 4
GMS FILE No. 3800

© SECURITY2023-051130 - GEC02022023-05002.dwg - SWD Property Site Plan, 05/20/2026 2:13:07 PM, jms, AutoCAD PDF (General Documentation).pc3, 1:1

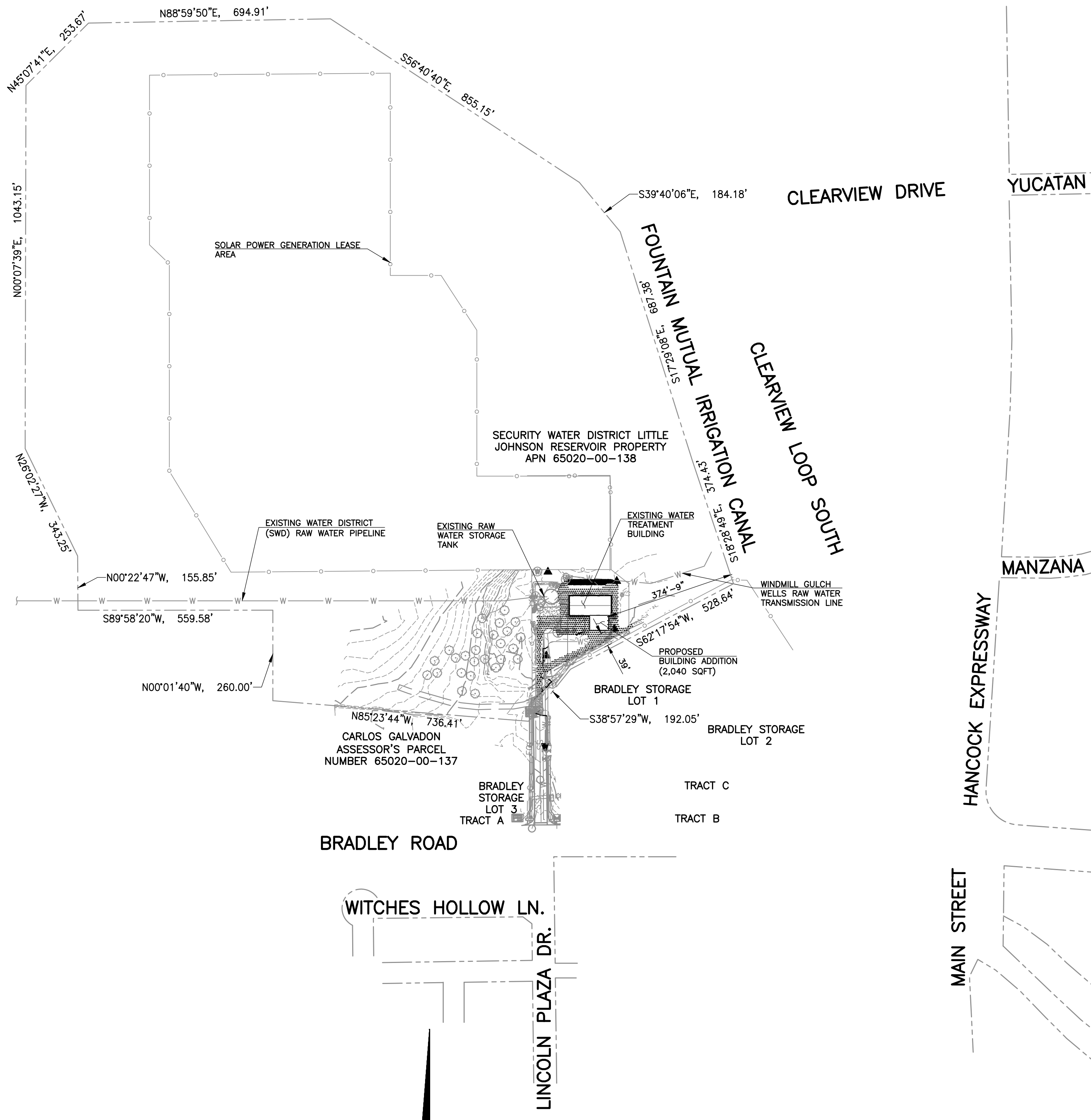

PROPERTY DESCRIPTION SECURITY WATER DISTRICT PARCEL:

A TRACT OF LAND BEING A PORTION OF THE SOUTHWEST QUARTER OF THE NORTHWEST QUARTER, THE SOUTH HALF OF THE NORTHEAST QUARTER, THE NORTH HALF OF THE SOUTHWEST QUARTER AND THE NORTH HALF OF THE NORTHEAST QUARTER OF THE SOUTHWEST QUARTER OF SECTION 2, TOWNSHIP 15 SOUTH, RANGE 66 WEST OF THE 6TH P.M. EL PASO COUNTY, COLORADO, BEING MORE PARTICULARLY DESCRIBED AS FOLLOWS:

BEGINNING AT THE NORTHWEST CORNER OF THE SOUTH HALF OF THE NORTH WEST QUARTER OF THE SOUTHWEST QUARTER OF SECTION 2, AS MONUMENTED BY A REBAR AND PLASTIC CAP PLS 9646;

THENCE N00°22'47"W A DISTANCE OF 155.85 FEET;

THENCE N26°02'27"W A DISTANCE OF 343.25 FEET;

THENCE N00°07'39"E A DISTANCE OF 1043.15 FEET;

THENCE N45°07'41"E A DISTANCE OF 253.67 FEET;

THENCE N88°59'50"E A DISTANCE OF 694.91 FEET;

THENCE S56°40'40"E A DISTANCE OF 855.15 FEET;

THENCE S39°40'06"E A DISTANCE OF 184.18 FEET;

THENCE S17°29'08"E A DISTANCE OF 687.38 FEET;

THENCE S18°18'49"E A DISTANCE OF 374.43 FEET TO A POINT ON THE NORTH LINE OF LOT 1, BRADLEY STORAGE SUBDIVISION AS SHOWN ON THE SUBDIVISION PLAT THEREOF RECORDED AT RECEPTION NUMBER 218714088 OF SAID EL PASO COUNTY RECORDS;

THENCE S62°17'54"W ON SAID NORTH LINE A DISTANCE OF 528.64 FEET TO AN ANGLE POINT THEREIN THENCE S38°57'29"W CONTINUING ON THE NORTHWESTERLY LINE OF SAID LOT 1 AND THE NORTHWESTERLY LINE OF LINCOLN PLAZA DRIVE AS PLATTED BY SAID SUBDIVISION A DISTANCE OF 192.05 FEET;

THENCE N85°23'44"W A DISTANCE OF 736.41 FEET;

THENCE N00°01'40"W A DISTANCE OF 260.00 FEET TO A POINT ON THE NORTH LINE OF THE SOUTH HALF OF THE NORTHWEST QUARTER OF THE SOUTHWEST QUARTER;

THENCE S89°58'20"W ON SAID NORTH LINE A DISTANCE OF 559.58 FEET TO THE POINT OF BEGINNING.

THE DESCRIBED TRACT CONTAINS 70.041 ACRES, MORE OR LESS

LEGEND

- WATER MAIN ——— W ——— W ——— W ———
- WATER SERVICE LINE ——— WS ——— WS ——— WS ———
- UNDERGROUND ELECTRIC ——— UGE ———
- GAS LINE ——— G ——— G ——— G ——— G ———
- FIBER OPTIC LINE ——— FO ———
- WASTEWATER PIPELINE ——— SS ——— SS ——— SS ———
- PROPERTY LINE - - - - -
- CHAIN LINK FENCE ——— ○ ——— ○ ——— ○ ——— ○ ———
- WATER VALVE ⊗
- FIRE HYDRANT ⊙
- WATER MANHOLE ⊕
- MONITORING WELL ⊕ MW
- ELECTRIC METER ⊕
- SOIL BORING ⊕
- SANITARY SEWER MANHOLE ○
- CONTROL POINT ▲



| | |
|-----------------------------------------------------------------------------------------------------------------------------------------------------------------------------------------------------|-------------------------|
| SCALE VERIFICATION | |
| BAR IS ONE INCH ON ORIGINAL DRAWING | |
| IF NOT ONE INCH ON THIS SHEET ADJUST SCALES ACCORDINGLY | |
| THIS DRAWING IS THE PROPERTY OF GMS, INC., AND IS NOT TO BE RE-PRODUCED, MODIFIED OR USED FOR ANY OTHER PROJECT WITHOUT THE WRITTEN CONSENT OF THE PROJECT ENGINEER BY AGREEMENT WITH THIS COMPANY. | |
| © 2024 GMS, INC. | |
| REVISIONS | |
| NO. | DATE |
| 1 | 3/31/2026 |
| DESCRIPTION | REVISED PER EPCPD NOTES |
| | |
| | |
| <p>SWD PROPERTY SITE PLAN WATER TREATMENT PLANT BUILDING ADDITION SECURITY WATER DISTRICT</p> | |
| <p>GMS, INC. CONSULTING ENGINEERS 611 N. WEBER, SUITE 300 COLORADO SPRINGS, COLORADO 80903</p> | |
| DRAWN | |
| DESIGNED | SKC |
| CHECKED | SLW |
| DATE | RJS |
| PROJECT NO. | 2023-053.130 |
| GMS FILE NO. | 3800 |
| <p>SHEET 2 OF 4</p> | |

LEGEND

- WATER MAIN — W — W — W —
- WATER SERVICE LINE — WS — WS — WS —
- UNDERGROUND ELECTRIC — UGE —
- GAS LINE — G — G — G — G —
- FIBER OPTIC LINE — FO —
- SANITATION SEWER LINE — SS — SS — SS —
- WATER VALVE ⊠
- SANITATION SEWER LINE ⊙
- WATER MANHOLE ⊗
- MONITORING WELL ⊕ MW
- ELECTRIC METER ⊖
- SOIL BORING ⊗
- SANITARY SEWER MANHOLE ⊙
- CONTROL POINT ▲

ASSESSOR'S NUMBER 65020-00-138

CARLOS GALVADON ASSESSOR'S PARCEL NUMBER
65020-00-137

BRADLEY STORAGE
LOT 3

BRADLEY STORAGE
LOT 1

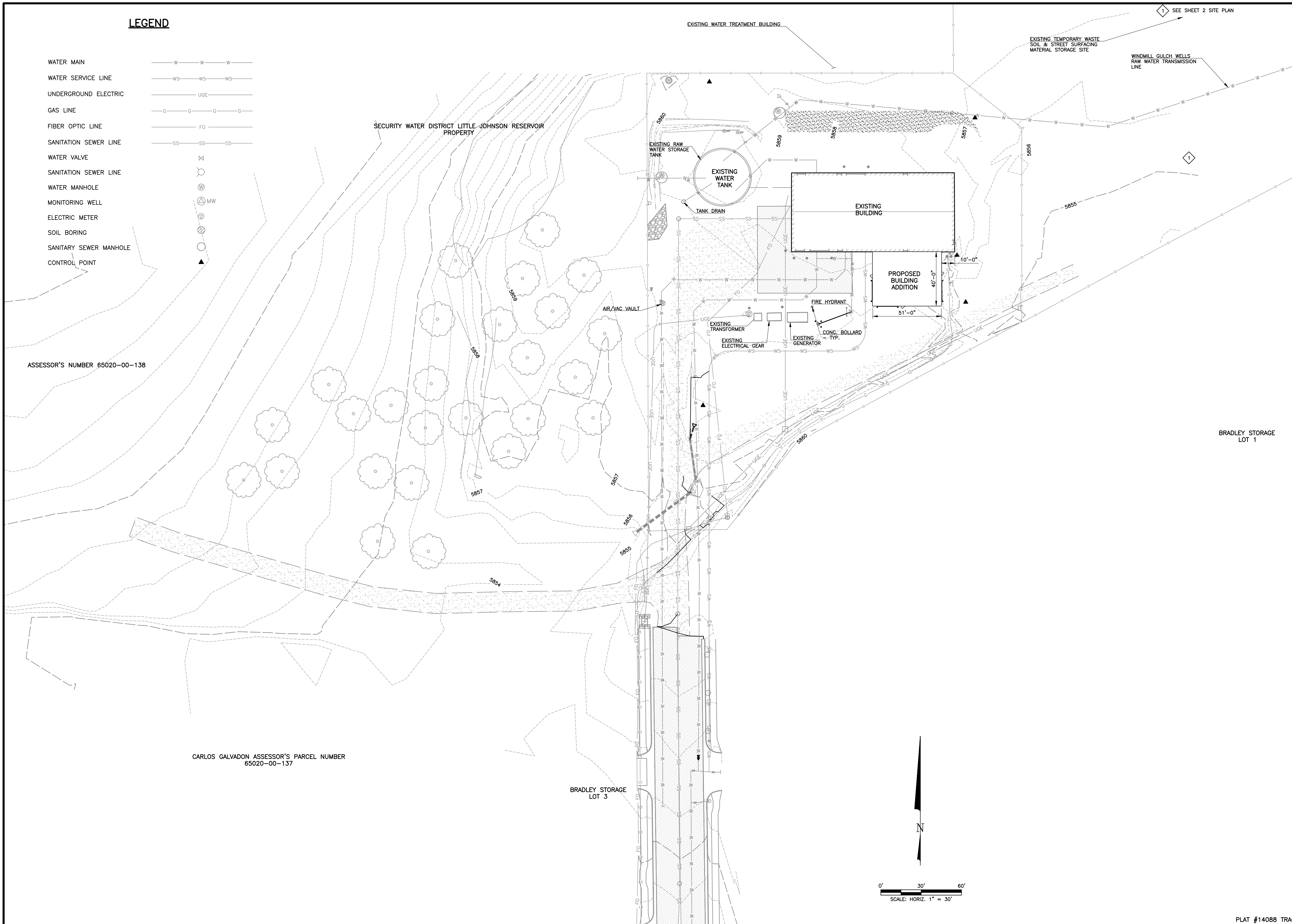

SCALE VERIFICATION

BAR IS ONE INCH ON ORIGINAL DRAWING
IF NOT ONE INCH ON THIS SHEET ADJUST SCALES ACCORDINGLY

THIS DRAWING IS THE PROPERTY OF GMS, INC., AND IS NOT TO BE RE-PRODUCED, MODIFIED OR USED FOR ANY OTHER PROJECT OR EXTENSION OF THIS PROJECT WITHOUT THE WRITTEN AGREEMENT WITH THIS COMPANY.
© 2024 GMS, INC.

| NO. | DATE | DESCRIPTION |
|-----|-----------|--------------------------|
| 1 | 3/31/2026 | REVISED PER EPCPCD NOTES |



BUILDING SITE PLAN
WATER TREATMENT PLANT BUILDING ADDITION
SECURITY WATER DISTRICT

GMS, INC.
CONSULTING ENGINEERS
611 N. WEBER, SUITE 300
COLORADO SPRINGS, COLORADO 80903

| DESIGNED | CHECKED | DATE |
|----------|---------|--------------|
| SLW | RJS | JANUARY 2026 |

PROJECT NO. 2023-053.130
GMS FILE NO. 3800

SHEET
3
4

© SECURITY/2023-053.130 - GED/0002023-053003.dwg, Blog Site Plan, 6/20/2024 2:13:12 PM, jms, AutoCAD PDF (General Documentation).pc3, 1:1

- STANDARD NOTES FOR EL PASO COUNTY GRADING AND EROSION CONTROL PLANS**
- NOTWITHSTANDING ANYTHING DEPICTED IN THESE PLANS IN WORDS OR GRAPHIC REPRESENTATION, ALL DESIGN AND CONSTRUCTION RELATED TO ROADS, STORM DRAINAGE, AND EROSION CONTROL SHALL CONFORM TO THE STANDARDS AND REQUIREMENTS OF THE MOST RECENT VERSION OF THE RELEVANT ADOPTED EL PASO COUNTY (EPC) STANDARDS, INCLUDING THE LAND DEVELOPMENT CODE (LDC), THE ENGINEERING CRITERIA MANUAL (ECM), THE DRAINAGE CRITERIA MANUAL (DCM) VOLUME 1 AND 2. ANY DEVIATIONS FROM REGULATIONS AND STANDARDS MUST BE REQUESTED, AND APPROVED, IN WRITING.
 - A PRECONSTRUCTION MEETING BETWEEN THE PERMIT HOLDER(S) AND EL PASO COUNTY SHALL BE HELD PRIOR TO ANY CONSTRUCTION ACTIVITIES. IT IS THE RESPONSIBILITY OF THE PERMIT HOLDER(S) TO COORDINATE THE MEETING TIME AND PLACE WITH COUNTY STAFF. NO LAND DISTURBANCE OR CONSTRUCTION ACTIVITIES BEYOND THE INSTALLATION OF THE INITIAL CONSTRUCTION CONTROL MEASURES (CCMS), AS INDICATED ON THE APPROVED GEC PLAN OR CDS WITH GEC PLANS, MAY OCCUR PRIOR TO RECEIVING A NOTICE TO PROCEED (NTP) ISSUED BY THE EPC ADMINISTRATOR. FAILURE TO OBTAIN A NOTICE TO PROCEED PRIOR TO BEGINNING LAND DISTURBING ACTIVITIES MAY RESULT IN AN IMMEDIATE STOP WORK ORDER (SWO).
 - CONSTRUCTION CONTROL MEASURES MUST BE INSTALLED PRIOR TO COMMENCEMENT OF ACTIVITIES THAT COULD CONTRIBUTE POLLUTANTS TO STORMWATER. STORMWATER RUNOFF FROM ALL DISTURBED AREAS AND SOIL STORAGE AREAS MUST UTILIZE OR FLOW TO ONE OR MORE CCM(S) TO MINIMIZE EROSION OR SEDIMENT IN THE DISCHARGE. THE CCM(S) MUST CONTAIN OR FILTER FLOWS IN ORDER TO PREVENT THE BYPASS OF FLOWS WITHOUT TREATMENT AND MUST BE APPROPRIATE FOR STORMWATER RUNOFF FROM DISTURBED AREAS AND FOR THE EXPECTED FLOW RATE, DURATION, AND FLOW CONDITIONS (E.G., SHEET OR CONCENTRATED FLOW).
 - ALL CCM(S) SHALL BE MAINTAINED AND REMAIN IN EFFECTIVE OPERATING CONDITION UNTIL FINAL STABILIZATION IS ACHIEVED. THE QUALIFIED STORMWATER MANAGER (OSM) SHALL ASSESS THE ADEQUACY OF CCM(S) AT THE SITE AND IDENTIFY IF CHANGES TO THOSE CCM(S) ARE NEEDED TO ENSURE THE CONTINUED EFFECTIVE PERFORMANCE OF THE CCM(S).
 - PRIOR TO CONSTRUCTION THE PERMIT HOLDER(S) SHALL VERIFY THE LOCATION OF EXISTING UTILITIES.
 - MANAGEMENT OF THE STORMWATER MANAGEMENT PLAN (SWMP) DURING CONSTRUCTION IS THE RESPONSIBILITY OF THE DESIGNATED OSM. THE SWMP SHALL BE LOCATED ON-SITE OR DIGITALLY ACCESSIBLE AT ALL TIMES DURING CONSTRUCTION ACTIVITIES AND MUST BE IMPLEMENTED AS WRITTEN FROM THE START OF CONSTRUCTION ACTIVITY UNTIL FINAL STABILIZATION IS ACHIEVED. THE OSM SHALL AMEND THE SWMP WHEN THERE IS A CHANGE IN DESIGN, CONSTRUCTION, OPERATION, OR MAINTENANCE OF THE SITE WHICH WOULD REQUIRE THE IMPLEMENTATION OF NEW OR REVISED CCM(S) OR IF THE SWMP PROVES TO BE INEFFECTIVE IN CONTROLLING POLLUTANTS IN STORMWATER RUNOFF ASSOCIATED WITH CONSTRUCTION ACTIVITY OR WHEN CCM(S) ARE NO LONGER NECESSARY AND ARE REMOVED. THE OSM SHALL MAINTAIN A RECORD OF AMENDMENTS MADE TO THE SWMP THAT INCLUDES THE DATE AND IDENTIFICATION OF THE CHANGES.
 - EARTH DISTURBANCES SHALL BE CONDUCTED IN SUCH A MANNER SO AS TO EFFECTIVELY MINIMIZE ACCELERATED SOIL EROSION AND RESULTING SEDIMENTATION. ALL DISTURBANCES SHALL BE DESIGNED, CONSTRUCTED, AND COMPLETED SO THAT THE EXPOSED AREA OF ANY DISTURBED LAND SHALL BE LIMITED TO THE SHORTEST PRACTICAL PERIOD OF TIME. PRE-EXISTING VEGETATION SHALL BE PROTECTED AND MAINTAINED WITHIN 50 HORIZONTAL FEET OF A RECEIVING WATER UNLESS SHOWN TO BE INFEASIBLE AND SPECIFICALLY REQUESTED AND APPROVED. IN ADDITION TO MAINTAINING 50 HORIZONTAL FEET OF PRE-EXISTING VEGETATION UPGRADIENT OF A RECEIVING WATER (UNLESS INFEASIBLE AND APPROVED), THE PERMIT HOLDER(S) MUST INSTALL CCM(S) UPGRADIENT OF THE VEGETATIVE BUFFER.
 - TEMPORARY STABILIZATION MEASURES SHALL BE IMPLEMENTED ON DISTURBED AREAS AND STOCKPILES WHERE GROUND DISTURBING CONSTRUCTION ACTIVITY HAS PERMANENTLY CEASED OR TEMPORARILY CEASED FOR LONGER THAN 14 DAYS.
 - EROSION CONTROL BLANKET (ECB) OR OTHER APPROVED CONTROL MEASURE(S) SHALL BE USED ON SLOPES STEEPER THAN 3:1.
 - VEHICLE TRACKING CONTROLS (VTC) MUST BE IMPLEMENTED TO MINIMIZE VEHICLE TRACKING OF SEDIMENT FROM DISTURBED AREAS. VTC'S MUST INCLUDE A STRUCTURE CONTROL MEASURE (E.G., TRACKING PAD) AND MAY INCLUDE A NON-STRUCTURAL CONTROL MEASURE (E.G., SWEEPING). MATERIAL TRACKED OFF-SITE SHALL BE CLEANED UP AND PROPERLY DISPOSED OF IMMEDIATELY.
 - ANY TEMPORARY OR PERMANENT CONTROL MEASURE DESIGNED AND CONSTRUCTED FOR THE CONVEYANCE OF STORMWATER AROUND, THROUGH, OR FROM THE EARTH DISTURBANCE AREA SHALL BE A STABILIZED CONVEYANCE DESIGNED TO MINIMIZE EROSION AND THE DISCHARGE OF SEDIMENT OFF-SITE.
 - NO PERSON SHALL CAUSE THE IMPEDIMENT OF STORMWATER FLOW IN THE CURB AND GUTTER, PERMANENT CONTROL MEASURES (PCMS), OR DITCHES EXCEPT WITH APPROVED SEDIMENT CONTROL MEASURES.
 - ALL PCMS SHALL BE INSTALLED AS DESIGNED IN THE APPROVED PLANS. ANY PROPOSED CHANGES THAT AFFECT THE DESIGN OR FUNCTION OF PCMS MUST BE APPROVED BY THE EPC ADMINISTRATOR PRIOR TO IMPLEMENTATION.
 - SOIL COMPACTION MUST BE MINIMIZED IN AREAS WHERE INFILTRATION PCMS WILL BE INSTALLED OR IN AREAS WHERE FINAL STABILIZATION WILL BE ACHIEVED BY VEGETATIVE COVER. AREAS DESIGNATED FOR INFILTRATION PCMS SHALL ALSO BE PROTECTED FROM SEDIMENTATION DURING CONSTRUCTION UNTIL FINAL STABILIZATION IS ACHIEVED. IF SOIL COMPACTION DOES OCCUR IN AREAS WHERE FINAL STABILIZATION WILL BE ACHIEVED BY VEGETATIVE COVER OR IN AREAS WHERE INFILTRATION PCMS WILL BE INSTALLED, DECOMPACTION OF THE SOIL MUST BE COMPLETED PRIOR TO PLANTING OR INSTALLATION OF THE PCMS). AN INFILTRATION TEST MUST BE CONDUCTED FOR ALL INFILTRATION PCMS AND THE INFILTRATION TEST RESULTS SUBMITTED TO EL PASO COUNTY PRIOR TO PRELIMINARY ACCEPTANCE (PA).
 - FINAL STABILIZATION MUST BE IMPLEMENTED AT ALL APPLICABLE CONSTRUCTION SITES. FINAL STABILIZATION IS ACHIEVED WHEN ALL GROUND DISTURBING ACTIVITIES AT THE SITE HAVE BEEN COMPLETED AND PERMANENT STABILIZATION METHODS ARE COMPLETE. WHEN USING VEGETATIVE COVER AS A PERMANENT STABILIZATION METHOD, THE VEGETATION SHALL BE EVENLY DISTRIBUTED PERENNIAL VEGETATION AND OF THE VARIETY AND SPECIES FOUND IN THE COUNTY-APPROVED SEED MIXES OR IN THE APPROVED GEC PLAN. VEGETATION COVERAGE SHALL BE, AT A MINIMUM, EQUAL TO 70% OF WHAT WOULD HAVE BEEN PROVIDED BY NATIVE VEGETATION IN A LOCAL, UNDISTURBED AREA OR ADEQUATE REFERENCE SITE. ALL TEMPORARY CCM(S) SHALL BE REMOVED UPON FINAL STABILIZATION AND PRIOR TO STORMWATER PERMIT TERMINATION.
 - STORMWATER DISCHARGES FROM CONSTRUCTION SITES SHALL NOT CAUSE OR THREATEN TO CAUSE POLLUTION, CONTAMINATION, OR DEGRADATION OF STATE WATERS. ALL WORK AND EARTH DISTURBANCE SHALL BE DONE IN A MANNER THAT MINIMIZES POLLUTION OF ANY ON-SITE OR OFF-SITE WATERS, INCLUDING WETLANDS.
 - CONCRETE WASH WATER SHALL BE CONTAINED AND DISPOSED OF IN ACCORDANCE WITH THE SWMP. NO WASH WATER SHALL BE DISCHARGED TO OR ALLOWED TO BE DISCHARGED OFF-SITE OR TO ENTER STATE WATERS, INCLUDING ANY SURFACE OR SUBSURFACE STORM DRAINAGE SYSTEM OR CONTROL MEASURES. CONCRETE WASHOUT AREAS SHALL NOT BE LOCATED IN AN AREA WHERE SHALLOW GROUNDWATER MAY BE PRESENT, OR WITHIN 50 FEET OF A SURFACE WATER BODY, CREEK, OR STREAM.
 - DURING CONSTRUCTION DEWATERING OPERATIONS, UNCONTAMINATED GROUNDWATER MAY BE DISCHARGED ON-SITE IN ACCORDANCE WITH THE COLORADO DEPARTMENT OF PUBLIC HEALTH AND ENVIRONMENT'S (CDPHE) LOW RISK DISCHARGE GUIDANCE POLICY FOR DISCHARGES OF UNCONTAMINATED GROUNDWATER TO LAND. IF CONSTRUCTION DEWATERING OPERATIONS ARE UNABLE TO MEET ALL CRITERIA, CONDITIONS, AND CONTROL MEASURE REQUIREMENTS OF THE LOW RISK DISCHARGE GUIDANCE POLICY, A COLORADO DISCHARGE PERMIT SYSTEM (CDPS) GENERAL PERMIT CDG080000 WILL BE REQUIRED.
 - CONTRACTOR SHALL BE RESPONSIBLE FOR THE REMOVAL OF ALL WASTE FROM THE CONSTRUCTION SITE FOR DISPOSAL IN ACCORDANCE WITH LOCAL AND STATE REGULATORY REQUIREMENTS. NO CONSTRUCTION DEBRIS, TREE SLASH, BUILDING MATERIAL WASTES, OR UNUSED BUILDING MATERIALS SHALL BE BURIED, DUMPED, OR DISCHARGED AT THE SITE.
 - THE PERMIT HOLDER(S) SHALL BE RESPONSIBLE FOR THE REMOVAL OF ALL CONSTRUCTION DEBRIS, DIRT, TRASH, ROCK, SEDIMENT, SOIL, AND SAND THAT MAY ACCUMULATE IN ROADS, STORM DRAINS AND OTHER DRAINAGE CONVEYANCE SYSTEMS AND STORMWATER APPURTENANCES AS A RESULT OF SITE DEVELOPMENT.
 - THE QUANTITY OF MATERIALS STORED ON THE PROJECT SITE SHALL BE LIMITED, TO THAT QUANTITY REQUIRED TO PERFORM THE WORK IN AN ORDERLY SEQUENCE. ALL MATERIALS STORED ON-SITE SHALL BE STORED IN A NEAT, ORDERLY MANNER, IN THEIR ORIGINAL CONTAINERS, WITH ORIGINAL MANUFACTURER'S LABELS.
 - MATERIALS SHALL NOT BE TEMPORARILY PLACED OR STORED IN THE STREET, ALLEY, OR OTHER PUBLIC WAY, UNLESS IN ACCORDANCE WITH AN APPROVED TRAFFIC CONTROL PLAN. APPROPRIATE CMS SHALL BE UTILIZED BASED ON SPECIFIC CONDITIONS AND CIRCUMSTANCES.
 - BULK STORAGE (I.E., INDIVIDUAL CONTAINERS OF 55 GALLONS OR GREATER) OF ALLOWED PETROLEUM PRODUCTS OR OTHER ALLOWED LIQUID SHALL REQUIRE ADEQUATE SECONDARY CONTAINMENT, OR EQUIVALENT PROTECTION, TO CONTAIN ALL SPILLS ON-SITE AND TO PREVENT ANY SPILLED MATERIALS FROM ENTERING STATE WATERS, ANY SURFACE OR SUBSURFACE STORM DRAINAGE SYSTEM, OR OTHER FACILITIES.
 - NO CHEMICAL(S) HAVING THE POTENTIAL TO BE RELEASED IN STORMWATER ARE TO BE STORED OR USED ON-SITE UNLESS PERMISSION FOR THE USE OF SUCH CHEMICAL(S) IS GRANTED IN WRITING BY THE EPC ADMINISTRATOR. IN GRANTING APPROVAL FOR THE USE OF SUCH CHEMICAL(S), SPECIAL CONDITIONS AND MONITORING MAY BE REQUIRED.
 - ON AREAS OF EXPOSED SOIL, MINIMIZE DUST THROUGH THE APPROPRIATE APPLICATION OF WATER OR OTHER DUST SUPPRESSION TECHNIQUES. WATER APPLICATION MUST BE CONDUCTED IN A MANNER TO PREVENT DISCHARGE OFF-SITE UNLESS AUTHORIZED BY A CDPS OR NATIONAL POLLUTANT DISCHARGE ELIMINATION SYSTEM (NPDES) PERMIT.
 - ALL CONSTRUCTION TRAFFIC MUST ENTER/EXIT THE SITE ONLY AT APPROVED CONSTRUCTION ACCESS POINTS.
 - FOR SITES WHERE A SOILS REPORT IS REQUIRED, THE APPROVED SOILS REPORT FOR THIS SITE SHALL BE CONSIDERED A PART OF THESE PLANS.
 - PERMIT HOLDER(S) AND THEIR AGENTS SHALL COMPLY WITH THE "COLORADO WATER QUALITY CONTROL ACT" (TITLE 25, ARTICLE 8, CRS), AND THE "CLEAN WATER ACT" (33 USC 1344), IN ADDITION TO THE REQUIREMENTS OF THE LAND DEVELOPMENT CODE, DRAINAGE CRITERIA MANUAL VOLUME 2, AND ENGINEERING CRITERIA MANUAL. ALL APPLICABLE LOCAL, STATE, AND FEDERAL PERMITS MUST BE OBTAINED PRIOR TO CONSTRUCTION. IN THE EVENT OF CONFLICTS BETWEEN THESE REQUIREMENTS AND OTHER LAWS, RULES, OR REGULATIONS OF OTHER FEDERAL, STATE, LOCAL, OR COUNTY AGENCIES, THE MOST RESTRICTIVE LAWS, RULES, OR REGULATIONS SHALL APPLY.
 - AT LEAST TEN (10) DAYS PRIOR TO THE ANTICIPATED START OF CONSTRUCTION, FOR PROJECTS THAT WILL DISTURB ONE (1) ACRE OR MORE OR LESS THAN 1 ACRE AND PART OF A LARGER COMMON PLAN OF DEVELOPMENT OR SALE THAT WOULD DISTURB 1 OR MORE ACRES, THE PERMIT HOLDER(S) SHALL SUBMIT A PERMIT APPLICATION FOR STORMWATER DISCHARGE (COR400000 PERMIT) TO THE CDPHE WATER QUALITY DIVISION. THE APPLICATION CONTAINS CERTIFICATION OF COMPLETION OF A SWMP, OF WHICH THIS GEC PLAN MAY BE A PART. FOR INFORMATION OR APPLICATION MATERIALS CONTACT: COLORADO DEPARTMENT OF PUBLIC HEALTH AND ENVIRONMENT WATER QUALITY CONTROL DIVISION WQCO - PERMITS 4300 CHERRY CREEK DRIVE SOUTH DENVER, CO 80246-1530 ATTN: PERMITS UNIT

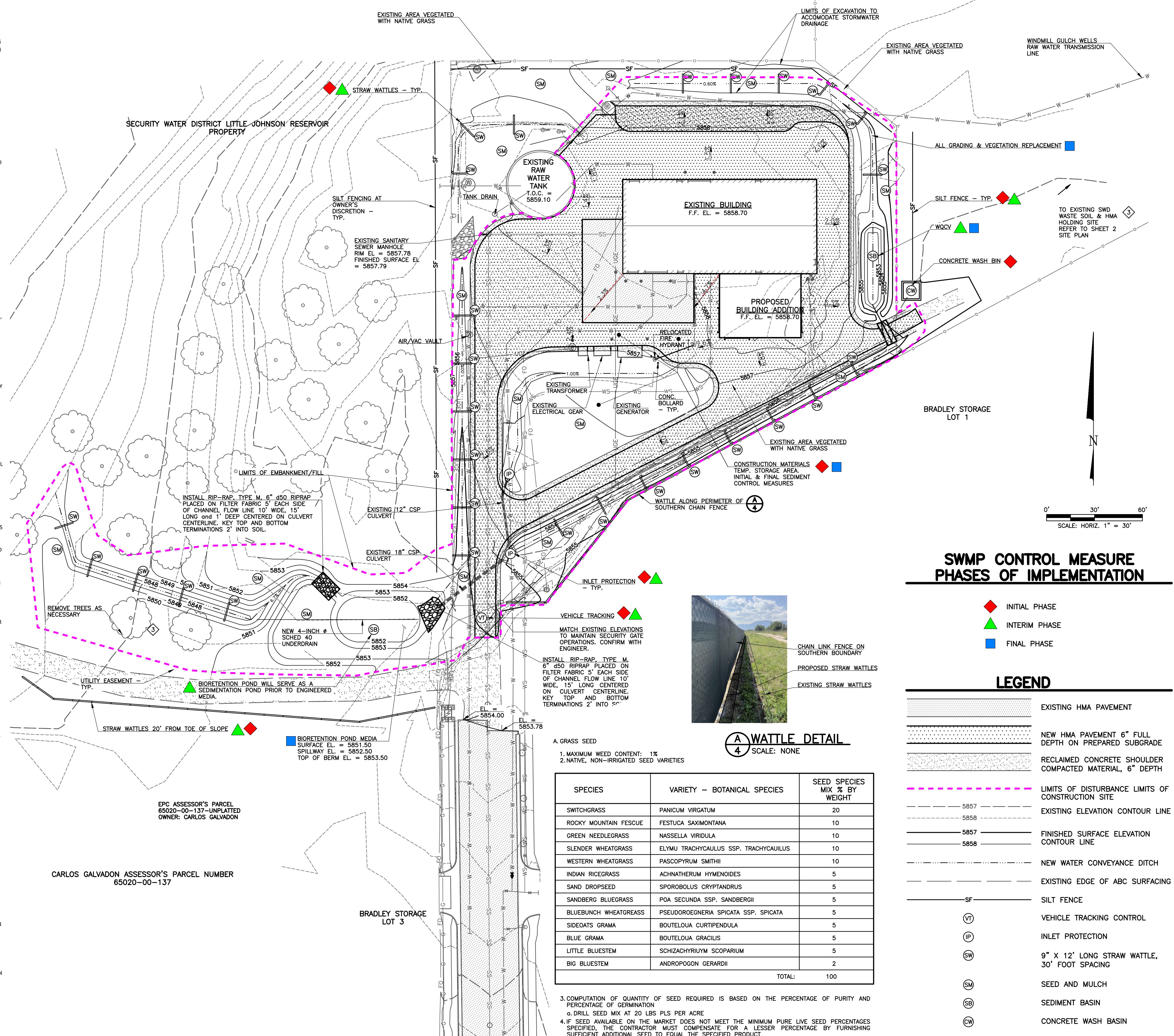

SWMP CONTROL MEASURE PHASES OF IMPLEMENTATION

- ◆ INITIAL PHASE
- ▲ INTERIM PHASE
- FINAL PHASE

LEGEND

- EXISTING HMA PAVEMENT
- NEW HMA PAVEMENT 6" FULL DEPTH ON PREPARED SUBGRADE
- RECLAIMED CONCRETE SHOULDER COMPACTED MATERIAL, 6" DEPTH
- LIMITS OF DISTURBANCE LIMITS OF CONSTRUCTION SITE
- EXISTING ELEVATION CONTOUR LINE
- FINISHED SURFACE ELEVATION CONTOUR LINE
- NEW WATER CONVEYANCE DITCH
- EXISTING EDGE OF ABC SURFACING
- SILT FENCE
- VEHICLE TRACKING CONTROL
- INLET PROTECTION
- 9" X 12" LONG STRAW WATTLE, 30' FOOT SPACING
- SEED AND MULCH
- SEDIMENT BASIN
- CONCRETE WASH BASIN



(A) WATTLE DETAIL
SCALE: NONE

| SPECIES | VARIETY - BOTANICAL SPECIES | SEED SPECIES MIX % BY WEIGHT |
|-----------------------|---------------------------------------|------------------------------|
| SWITCHGRASS | PANICUM VIRGATUM | 20 |
| ROCKY MOUNTAIN FESCUE | FESTUCA SAXIMONTANA | 10 |
| GREEN NEEDLEGRASS | NASSELLA VIRIDULA | 10 |
| SLENDER WHEATGRASS | ELYMU TRACHYCAULUS SSP. TRACHYCAULIUS | 10 |
| WESTERN WHEATGRASS | PASPOPYRUM SMITHII | 10 |
| INDIAN RICEGRASS | ACHNATHERUM HYMENOIDES | 5 |
| SAND DROPSEED | SPOROBOLUS CRYPTANDRUS | 5 |
| SANDBERG BLUEGRASS | POA SECUNDA SSP. SANDBERGII | 5 |
| BLUEBUNCH WHEATGRASS | PSEUDOROEGNERIA SPICATA SSP. SPICATA | 5 |
| SIDEOTS GRAMA | BOUTELOUA CURTIPENDULA | 5 |
| BLUE GRAMA | BOUTELOUA GRACILIS | 5 |
| LITTLE BLUESTEM | SCHIZACHRYRIUM SCOPARIUM | 5 |
| BIG BLUESTEM | ANDROPOGON GERARDII | 2 |
| TOTAL: | | 100 |

3. COMPUTATION OF QUANTITY OF SEED REQUIRED IS BASED ON THE PERCENTAGE OF PURITY AND PERCENTAGE OF GERMINATION
 G. DRILL SEED MIX AT 20 LBS PLS PER ACRE
 4. IF SEED AVAILABLE ON THE MARKET DOES NOT MEET THE MINIMUM PURE LIVE SEED PERCENTAGES SPECIFIED, THE CONTRACTOR MUST COMPENSATE FOR A LESSER PERCENTAGE BY FURNISHING SUFFICIENT ADDITIONAL SEED TO EQUAL THE SPECIFIED PRODUCT
 a. POUNDS OF SEED X (PURITY X GERMINATION) = POUNDS OF PURE LIVE SEED (PLS)

SCALE VERIFICATION
 BAR IS ONE INCH ON ORIGINAL DRAWING
 IF NOT ONE INCH ON THIS SHEET ADJUST SCALES ACCORDINGLY
 THIS DRAWING IS THE PROPERTY OF GMS, INC., AND IS NOT TO BE REPRODUCED, MODIFIED OR USED FOR ANY PURPOSE WITHOUT THE WRITTEN CONSENT OF THIS PROJECT'S DESIGNER. AGREEMENT WITH THIS COMPANY.
 © 2025 GMS, INC.

REVISIONS

| NO. | DATE | DESCRIPTION |
|-----|------------|------------------------------------|
| 1 | 12/31/2024 | ISSUED FOR BIDDING |
| 2 | 9/17/2025 | ADDED BMPs / TESP |
| 3 | 3/31/2026 | REVISED PER EPCDC NOTES |
| 4 | 5/11/2026 | ADDED BIORETENTION POND PER EPCDC |
| 5 | 6/05/2026 | ADDED GEC PHASES OF IMPLEMENTATION |

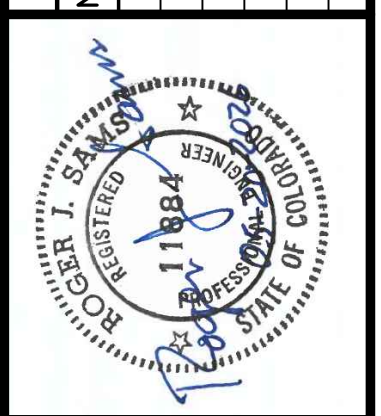

SITE GRADING, DRAINAGE, LANDSCAPING, AND EROSION CONTROL PLAN AND TREATMENT PLANT BUILDING ADDITION
 SECURITY WATER DISTRICT

GMS CONSULTING ENGINEERS INC.
 611 N. WEBER, SUITE 300
 COLORADO SPRINGS, COLORADO 80903
 719-475-2935

| SK/C | XX | R/S | DATE | PROJECT NO. | GMS FILE NO. |
|-------|----------|---------|------|--------------|--------------|
| DRAWN | DESIGNED | CHECKED | DATE | 2023-053-130 | 3800 |

SHEET **4** OF **4**

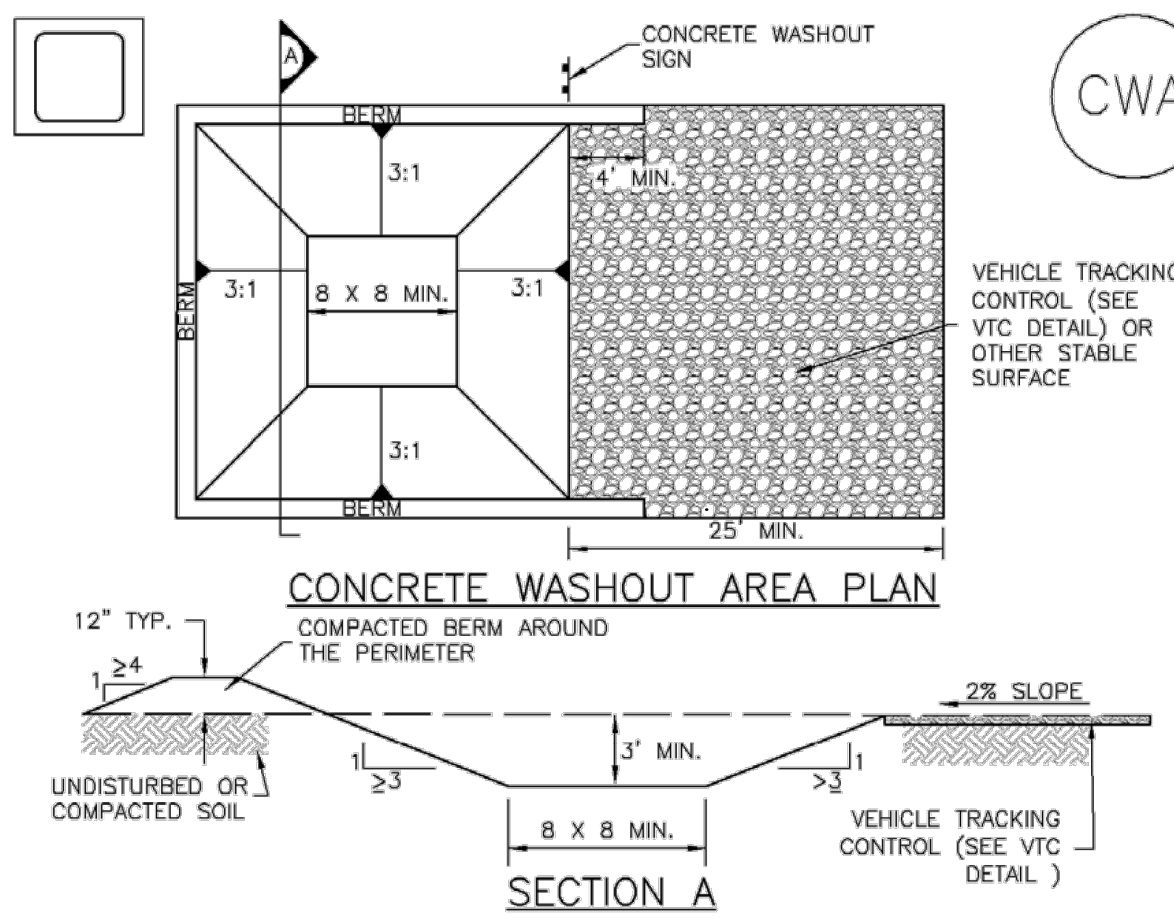

CWA-1. CONCRETE WASHOUT AREA

CWA INSTALLATION NOTES

- SEE PLAN VIEW FOR -CWA INSTALLATION LOCATION.
- DO NOT LOCATE AN UNLINED CWA WITHIN 400' OF ANY NATURAL DRAINAGE PATHWAY OR WATERBODY. DO NOT LOCATE WITHIN 1,000' OF ANY WELLS OR DRINKING WATER SOURCES. IF SITE CONSTRAINTS MAKE THIS INFESIBLE, OR IF HIGHLY PERMEABLE SOILS EXIST ON SITE, THE CWA MUST BE INSTALLED WITH AN IMPERMEABLE LINER (18 MIL MIN. THICKNESS) OR SURFACE STORAGE ALTERNATIVES USING PREFABRICATED CONCRETE WASHOUT DEVICES OR A LINED ABOVE GROUND STORAGE ARE SHOULD BE USED.
- THE CWA SHALL BE INSTALLED PRIOR TO CONCRETE PLACEMENT ON SITE.
- CWA SHALL INCLUDE A FLAT SUBSURFACE PIT THAT IS AT LEAST 8' BY 8' SLOPES LEADING OUT OF THE SUBSURFACE PIT SHALL BE 3:1 OR FLATTER. THE PIT SHALL BE AT LEAST 3' DEEP.
- BERM SURROUNDING SIDES AND BACK OF THE CWA SHALL HAVE MINIMUM HEIGHT OF 1'.
- VEHICLE TRACKING PAD SHALL BE SLOPED 2% TOWARDS THE CWA.
- SIGNS SHALL BE PLACED AT THE CONSTRUCTION ENTRANCE, AT THE CWA, AND ELSEWHERE AS NECESSARY TO CLEARLY INDICATE THE LOCATION OF THE CWA TO OPERATORS OF CONCRETE TRUCKS AND PUMP RIGS.
- USE EXCAVATED MATERIAL FOR PERIMETER BERM CONSTRUCTION.

CWA MAINTENANCE NOTES

- INSPECT BMPs EACH WORKDAY, AND MAINTAIN THEM IN EFFECTIVE OPERATING CONDITION. MAINTENANCE OF BMPs SHOULD BE PROACTIVE, NOT REACTIVE. INSPECT BMPs AS SOON AS POSSIBLE (AND ALWAYS WITHIN 24 HOURS) FOLLOWING A STORM THAT CAUSES SURFACE EROSION, AND PERFORM NECESSARY MAINTENANCE.
 - FREQUENT OBSERVATIONS AND MAINTENANCE ARE NECESSARY TO MAINTAIN BMPs IN EFFECTIVE OPERATING CONDITION. INSPECTIONS AND CORRECTIVE MEASURES SHOULD BE DOCUMENTED THOROUGHLY.
 - WHERE BMPs HAVE FAILED, REPAIR OR REPLACEMENT SHOULD BE INITIATED UPON DISCOVERY OF THE FAILURE.
 - THE CWA SHALL BE REPAIRED, CLEANED, OR ENLARGED AS NECESSARY TO MAINTAIN CAPACITY FOR CONCRETE WASTE, CONCRETE MATERIALS, ACCUMULATED IN PIT, SHALL BE REMOVED ONCE THE MATERIALS HAVE REACHED A DEPTH OF 2'.
 - CONCRETE WASHOUT WATER, WASTED PIECES OF CONCRETE AND ALL OTHER DEBRIS IN THE SUBSURFACE PIT SHALL BE TRANSPORTED FROM THE JOB SITE IN A WATER-TIGHT CONTAINER AND DISPOSED OF PROPERLY.
 - THE CWA SHALL REMAIN IN PLACE UNTIL ALL CONCRETE FOR THE PROJECT IS PLACED.
 - WHEN THE CWA IS REMOVED, COVER THE DISTURBED AREA WITH TOP SOIL, SEED AND MULCH OR OTHERWISE STABILIZED IN A MANNER APPROVED BY THE LOCAL JURISDICTION.
- (DETAILS ADAPTED FROM DOUGLAS COUNTY, COLORADO AND THE CITY OF PARKER, COLORADO, NOT AVAILABLE IN AUTOCAD).
NOTE: MANY JURISDICTIONS HAVE BMP DETAILS THAT VARY FROM UDFCD STANDARD DETAILS. CONSULT WITH LOCAL JURISDICTIONS AS TO WHICH DETAIL SHOULD BE USED WHEN DIFFERENCES ARE NOTED.

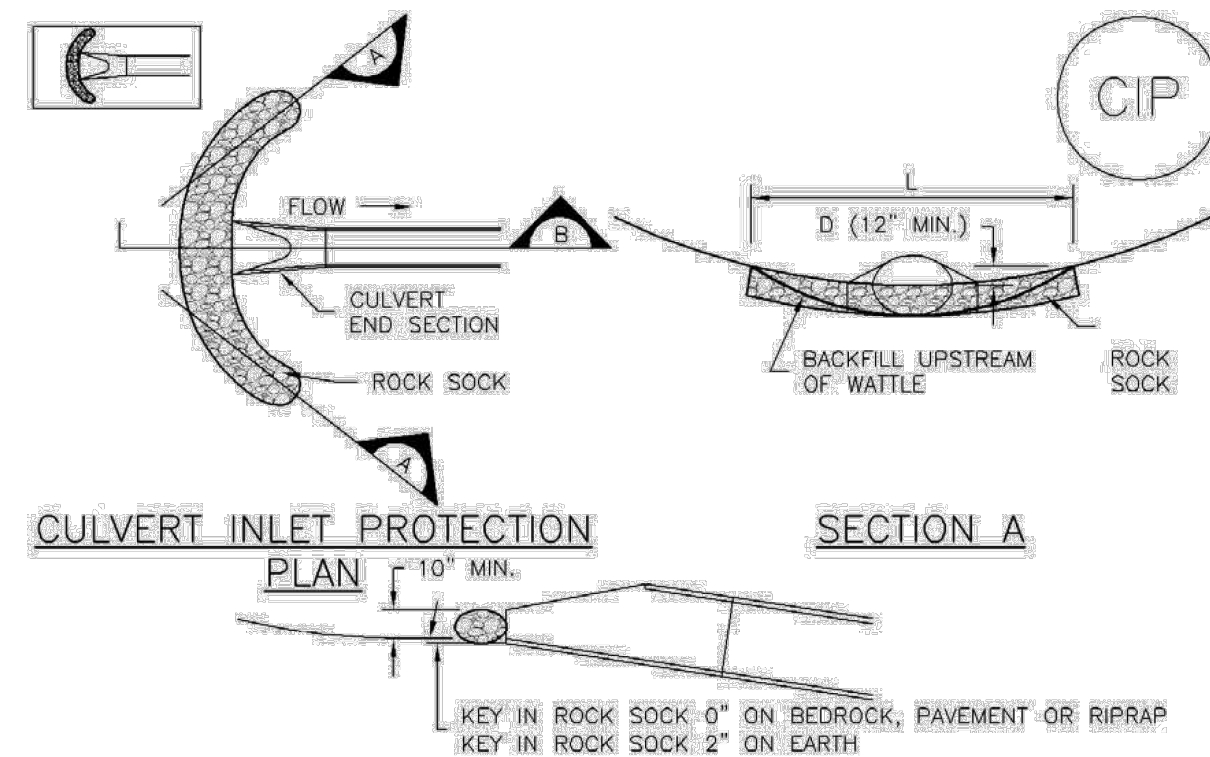

CIP-1. CULVERT INLET PROTECTION

CULVERT INLET PROTECTION INSTALLATION NOTES

- SEE PLAN VIEW FOR -LOCATION OF CULVERT INLET PROTECTION.
- SEE ROCK SOCK DESIGN DETAIL FOR ROCK GRADATION REQUIREMENTS AND JOINTING DETAIL.

CULVERT INLET PROTECTION MAINTENANCE NOTES

- INSPECT BMPs EACH WORKDAY, AND MAINTAIN THEM IN EFFECTIVE OPERATING CONDITION. MAINTENANCE OF BMPs SHOULD BE PROACTIVE, NOT REACTIVE. INSPECT BMPs AS SOON AS POSSIBLE (AND ALWAYS WITHIN 24 HOURS) FOLLOWING A STORM THAT CAUSES SURFACE EROSION, AND PERFORM NECESSARY MAINTENANCE.
 - FREQUENT OBSERVATIONS AND MAINTENANCE ARE NECESSARY TO MAINTAIN BMPs IN EFFECTIVE OPERATING CONDITION. INSPECTIONS AND CORRECTIVE MEASURES SHOULD BE DOCUMENTED THOROUGHLY.
 - WHERE BMPs HAVE FAILED, REPAIR OR REPLACEMENT SHOULD BE INITIATED UPON DISCOVERY OF THE FAILURE.
 - SEDIMENT ACCUMULATED UPSTREAM OF THE CULVERT SHALL BE REMOVED WHEN THE SEDIMENT DEPTH IS 1/2 THE HEIGHT OF THE ROCK SOCK.
 - CULVERT INLET PROTECTION SHALL REMAIN IN PLACE UNTIL THE UPSTREAM DISTURBED AREA IS PERMANENTLY STABILIZED AND APPROVED BY THE LOCAL JURISDICTION.
- (DETAILS ADAPTED FROM AURORA, COLORADO, NOT AVAILABLE IN AUTOCAD)
NOTE: MANY JURISDICTIONS HAVE BMP DETAILS THAT VARY FROM UDFCD STANDARD DETAILS. CONSULT WITH LOCAL JURISDICTIONS AS TO WHICH DETAIL SHOULD BE USED WHEN DIFFERENCES ARE NOTED.

CWA

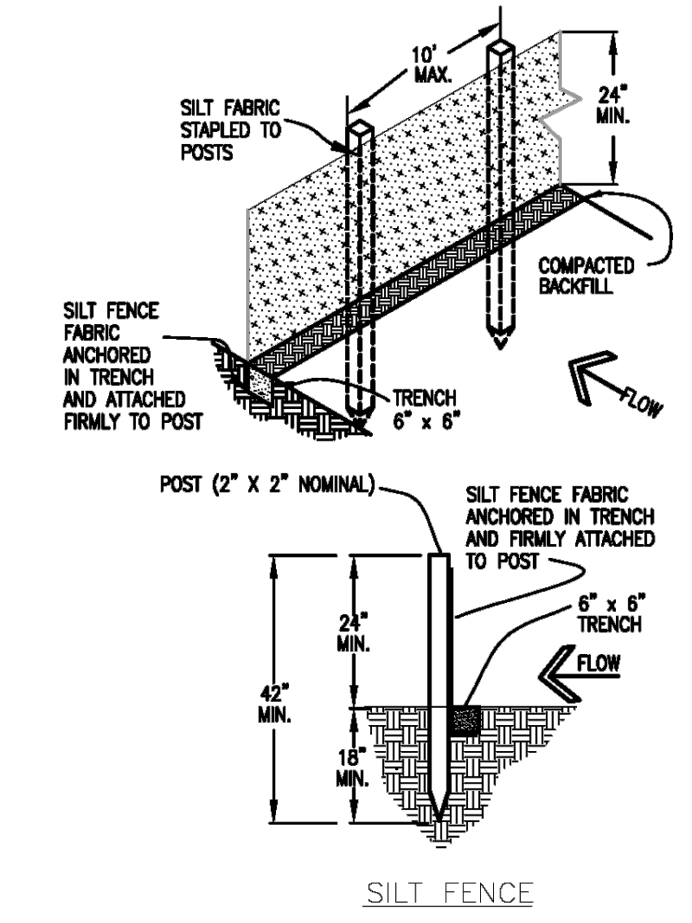

SILT FENCE

SILT FENCE NOTES

INSTALLATION REQUIREMENTS

- SILT FENCES SHALL BE INSTALLED PRIOR TO ANY LAND DISTURBING ACTIVITIES.
- WHEN JOINTS ARE NECESSARY, SILT FENCE GEOTEXTILE SHALL BE SPICED TOGETHER ONLY AT SUPPORT POST AND SECURELY SEALED.
- METAL POSTS SHALL BE "STUDDED TEE" OR "U" TYPE WITH MINIMUM WEIGHT OF 1.33 POUNDS PER LINEAR FOOT. WOOD POSTS SHALL HAVE A MINIMUM DIAMETER OR CROSS SECTION DIMENSION OF 2 INCHES.
- THE FILTER MATERIAL SHALL BE FASTENED SECURELY TO METAL OR WOOD POSTS USING WIRE TIES, OR TO WOOD POSTS WITH 3M" LONG #9 HEAVY-DUTY STAPLES. THE SILT FENCE GEOTEXTILE SHALL NOT BE STAPLED TO EXISTING TREES.
- WHILE NOT REQUIRED, WIRE MESH FENCE MAY BE USED TO SUPPORT THE GEOTEXTILE. WIRE FENCE SHALL BE FASTENED SECURELY TO THE UPSIDE OF THE POSTS USING HEAVY-DUTY WIRE STAPLES AT LEAST 3M" LONG. THE WIRES OR HOG RINGS, THE WIRE SHALL EXTEND INTO THE TRENCH A MINIMUM OF 6" AND SHALL NOT EXTEND MORE THAN 3' ABOVE THE ORIGINAL GROUND SURFACE.
- ALONG THE TOE OF FILLS, INSTALL THE SILT FENCE ALONG A LEVEL CONTOUR AND PROVIDE AN AREA BEHIND THE FENCE FOR RUNOFF TO POND AND SEDIMENT TO SETTLE. A MINIMUM DISTANCE OF 8 FEET FROM THE TOE OF THE FILL IS RECOMMENDED.
- THE HEIGHT OF THE SILT FENCE FROM THE GROUND SURFACE SHALL BE MINIMUM OF 24 INCHES AND SHALL NOT EXCEED 36 INCHES; HIGHER FENCES MAY INPOUND VOLUMES OF WATER SUFFICIENT TO CAUSE FAILURE OF THE STRUCTURE.

MAINTENANCE REQUIREMENTS

- CONTRACTOR SHALL INSPECT SILT FENCES IMMEDIATELY AFTER EACH RAINFALL, AT LEAST DAILY DURING PROLONGED RAINFALL, AND WEEKLY DURING PERIODS OF NO RAINFALL. DAMAGED, COLLAPSED, UNTRENCHED OR INEFFECTIVE SILT FENCES SHALL BE PROMPTLY REPAIRED OR REPLACED.
- SEDIMENT SHALL BE REMOVED FROM BEHIND SILT FENCE WHEN IT ACCUMULATES TO HALF THE EXPOSED GEOTEXTILE HEIGHT.
- SILT FENCES SHALL BE REMOVED WHEN ADEQUATE VEGETATIVE COVER IS ATTAINED AS APPROVED BY THE CITY.

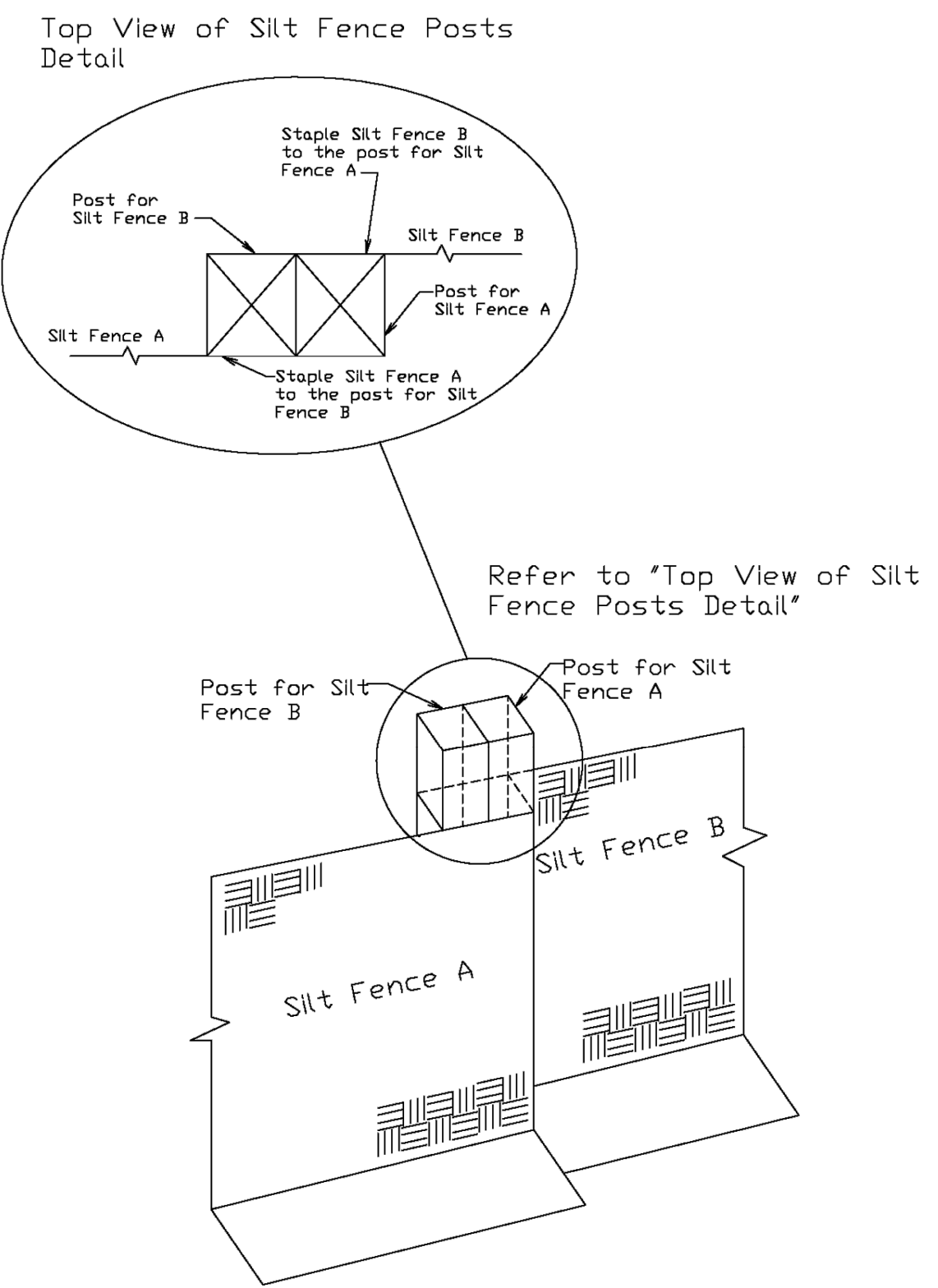

Refer to 'Top View of Silt Fence Posts Detail'

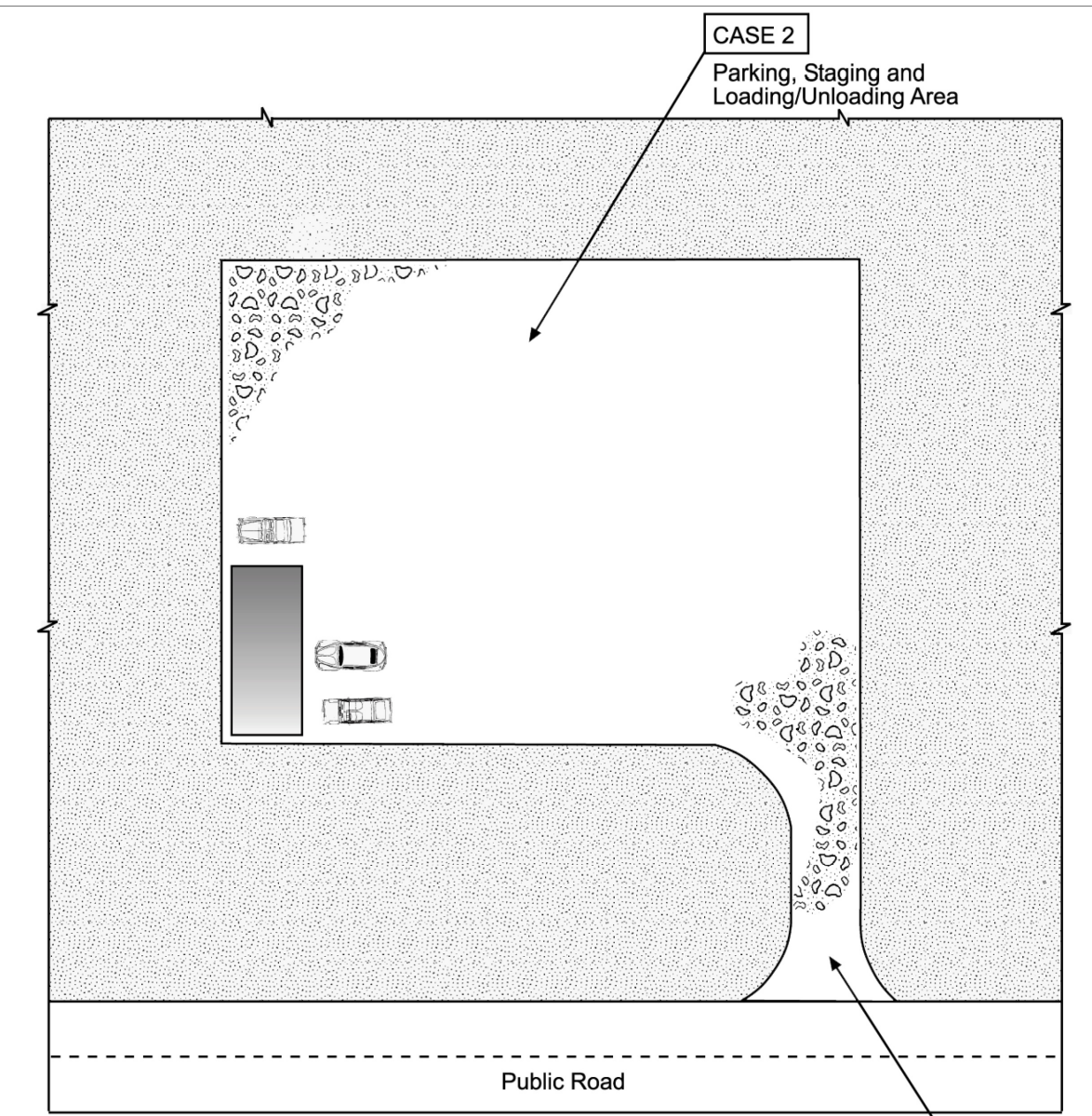
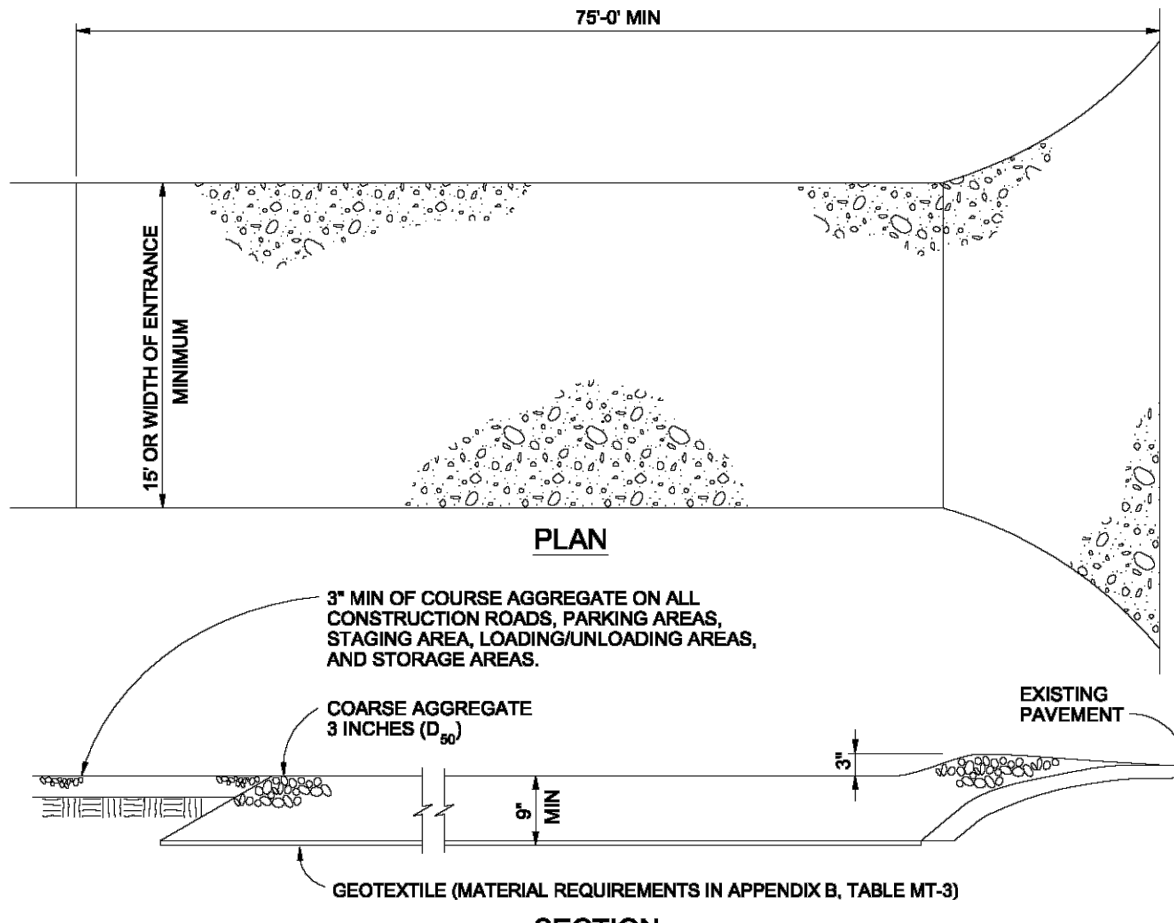

Table VT-1

| | Case 1 | Case 2 |
|------------------|--------|--------|
| Gravel Thickness | 9" | 3" |
| Filter Fabric | YES | NO |



VEHICLE TRACKING

VEHICLE TRACKING NOTES

INSTALLATION REQUIREMENTS

- ALL ENTRANCES TO THE CONSTRUCTION SITE ARE TO BE STABILIZED PRIOR TO CONSTRUCTION BEGINNING.
- CONSTRUCTION ENTRANCES ARE TO BE BUILT WITH AN APRON TO ALLOW FOR TURNING TRAFFIC, BUT SHOULD NOT BE BUILT OVER EXISTING PAVEMENT EXCEPT FOR A SLIGHT OVERLAP.
- AREAS TO BE STABILIZED ARE TO BE PROPERLY GRADED AND COMPACTED PRIOR TO LAYING DOWN GEOTEXTILE AND STONE.
- CONSTRUCTION ROADS, PARKING AREAS, LOADING/UNLOADING ZONES, STORAGE AREAS, AND STAGING AREAS ARE TO BE STABILIZED.
- CONSTRUCTION ROADS ARE TO BE BUILT TO CONFORM TO SITE GRADES, BUT SHOULD NOT HAVE SIDE SLOPES OR ROAD GRADES THAT ARE EXCESSIVELY STEEP.

MAINTENANCE REQUIREMENTS

- REGULAR INSPECTIONS ARE TO BE MADE OF ALL STABILIZED AREAS, ESPECIALLY AFTER STORM EVENTS.
- STONES ARE TO BE REAPPLIED PERIODICALLY AND WHEN REPAIR IS NECESSARY.
- SEDIMENT TRACKED ONTO PAVED ROADS IS TO BE REMOVED DAILY BY SHOVELING OR SWEEPING. SEDIMENT IS NOT TO BE WASHED DOWN STORM SEWER DRAINS.
- STORM SEWER INLET PROTECTION IS TO BE IN PLACE, INSPECTED, AND CLEANED IF NECESSARY.
- OTHER ASSOCIATED SEDIMENT CONTROL MEASURES ARE TO BE INSPECTED TO ENSURE GOOD WORKING CONDITION.

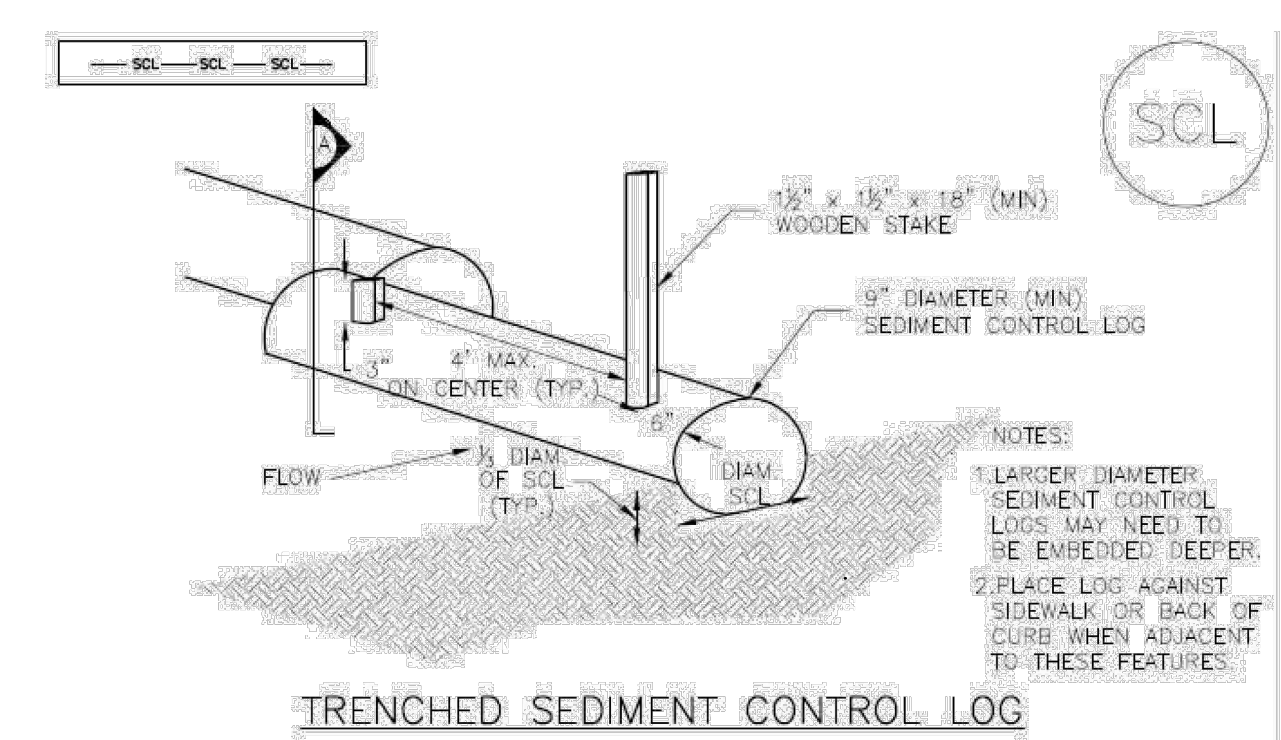

TRENCHED SEDIMENT CONTROL LOG

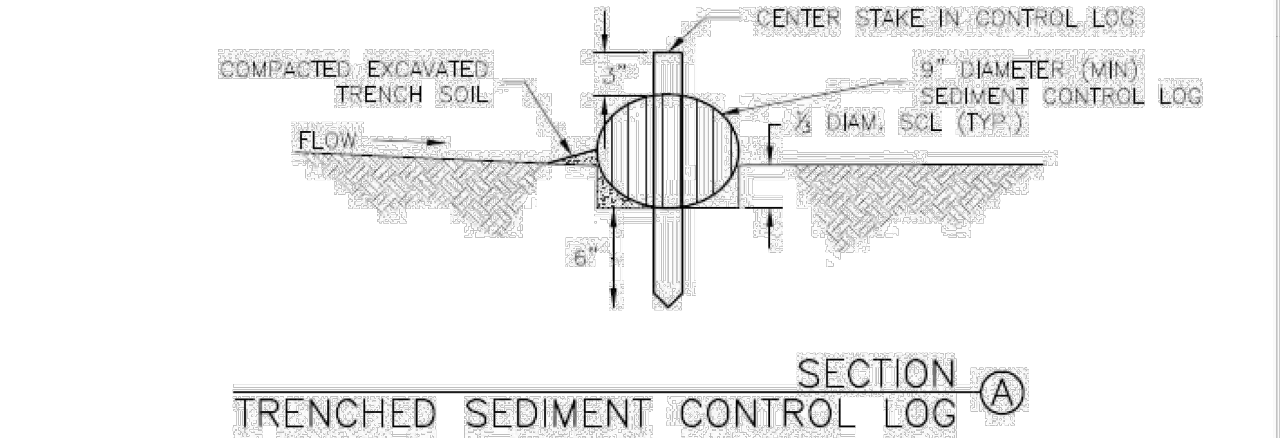

TRENCHED SEDIMENT CONTROL LOG

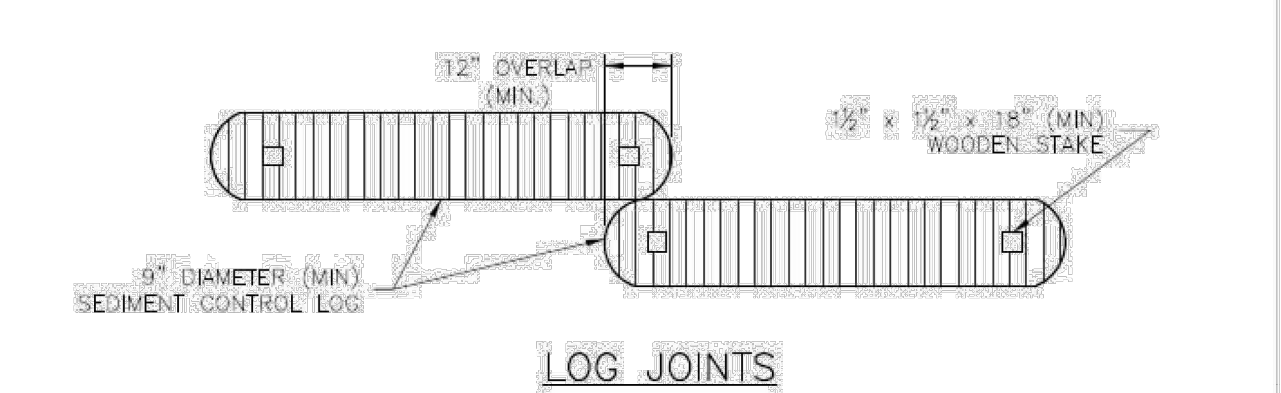

LOG JOINTS

SCL-1. TRENCHED SEDIMENT CONTROL LOG

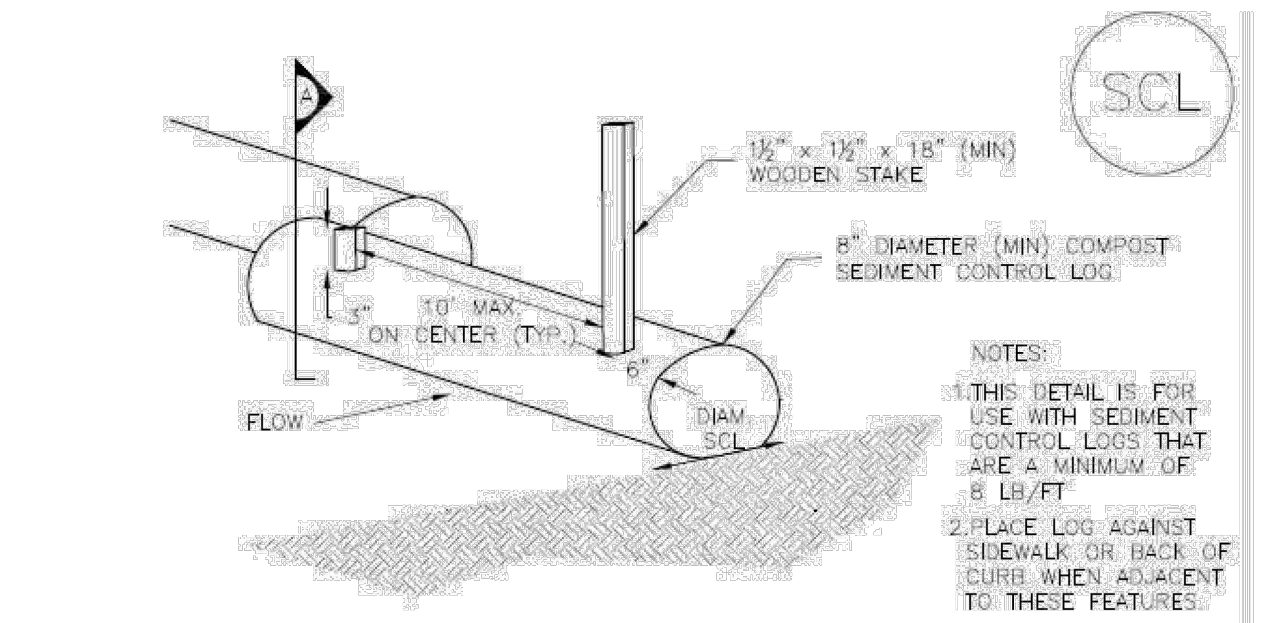

COMPOST SEDIMENT CONTROL LOG (WEIGHTED)

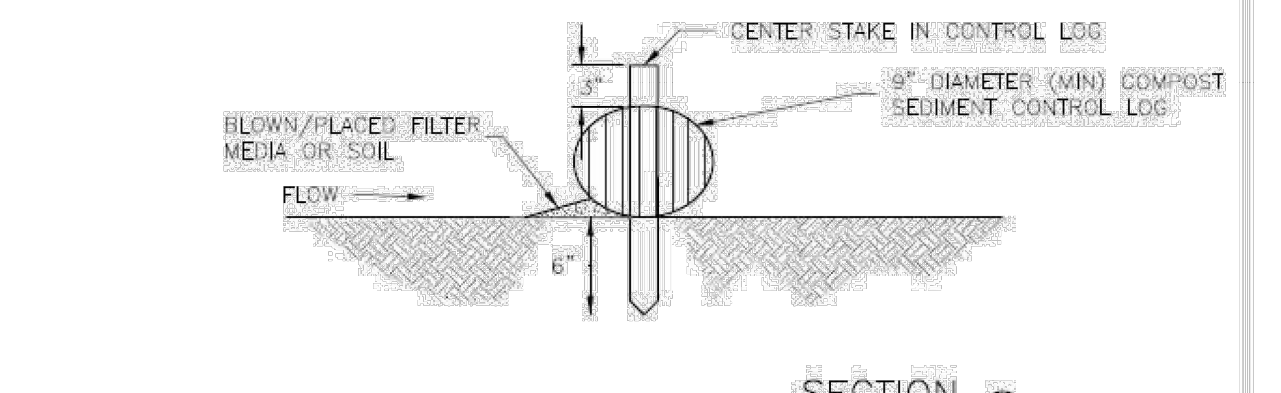

COMPOST SEDIMENT CONTROL LOG

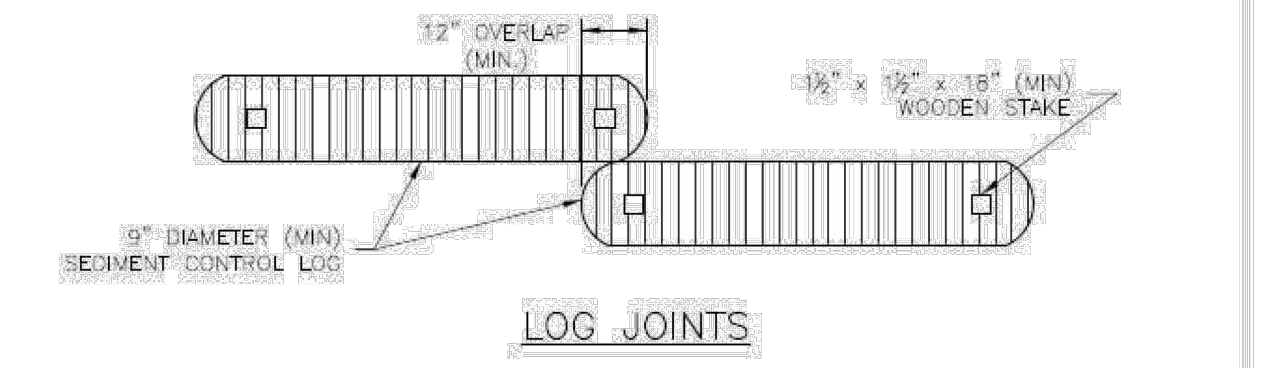

LOG JOINTS

SCL-2. COMPOST SEDIMENT CONTROL LOG (WEIGHTED)

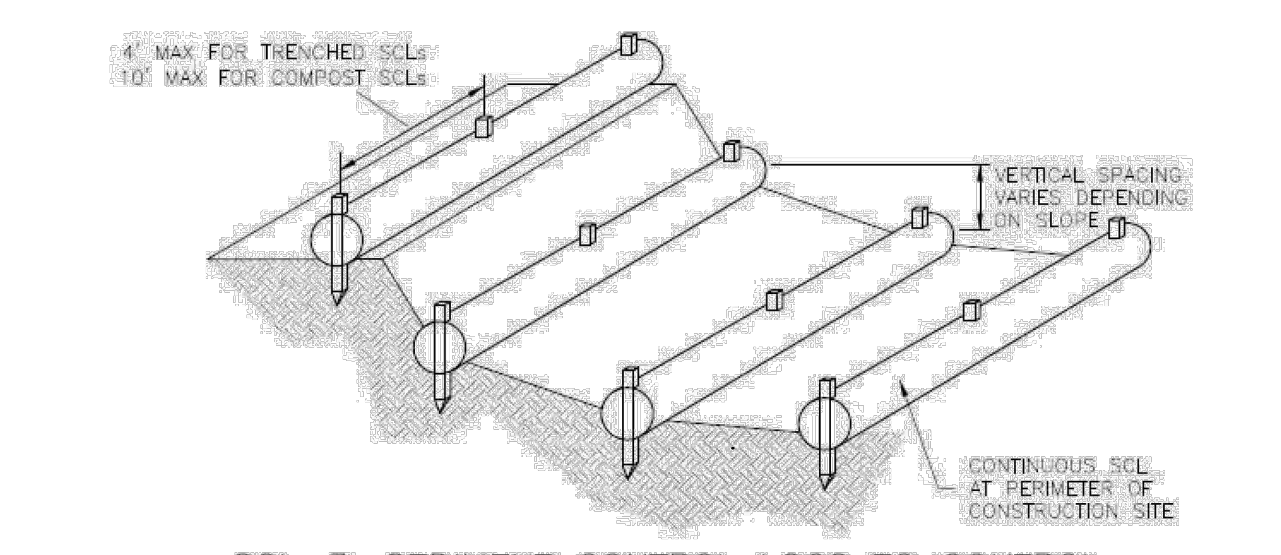

SCL-3. SEDIMENT CONTROL LOGS TO CONTROL SLOPE LENGTH

SCALE VERIFICATION
BAR IS ONE INCH ON ORIGINAL DRAWING
IF NOT ONE INCH ON THIS SHEET ADJUST SCALES ACCORDINGLY

THIS DRAWING IS THE PROPERTY OF GMS, INC., AND IS NOT TO BE REPRODUCED, MODIFIED OR USED FOR ANY OTHER PROJECT WITHOUT THE WRITTEN AGREEMENT WITH THIS COMPANY.
© 2025 GMS, INC.

REVISIONS

| NO. | DATE | DESCRIPTION |
|-----|-----------|------------------------------------|
| 1 | 5/12/2026 | ADDED DETAIL SHEET PER EPCOD NOTES |

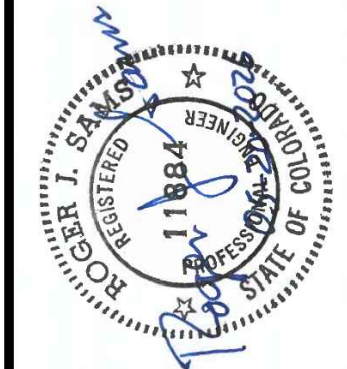

TEMPORARY EROSION CONTROL MEASURES CONSTRUCTION DETAILS
WATER TREATMENT PLANT BUILDING ADDITION
SECURITY WATER DISTRICT

GMS CONSULTING ENGINEERS
611 N. WEBER, SUITE 300
COLORADO SPRINGS, COLORADO 80903
719-475-2935

| | | | | | |
|-------|----------|---------|--------------|--------------|--------------|
| DRAWN | DESIGNED | CHECKED | DATE | PROJECT NO. | GMS FILE NO. |
| | XX | RJS | OCTOBER 2024 | 2023-053.130 | 3800 |

SHEET
4A
OF
4