

**STORMWATER MANAGEMENT PLAN (SWMP)
STORMWATER BEST MANAGEMENT PRACTICES**

For:

Lot 2 - Crossroads Mixed Use Filing No. 2

Grading & Erosion Control Plan

Located at:

~West Hwy 24 & Hwy 94, El Paso County

Prepared For:

**Developer: Crossroads Development Company, LLC, 90 South Cascade, Suite 1500,
Colorado Springs, 80903, Contact: Danny Mientka, 719-448-4034**

Contractor: TBD

Name:

Company:

Address:

Stormwater Manger: TBD

Name:

Company:

Address:

Prepared For:

Crossroads Development Company, LLC

**90 S Cascade, Ste 1500
Colorado Springs, CO 80903**

Contact: Danny Mientka

719-448-4034

Prepared by:



CIVIL CONSULTANTS, INC.

**212 Wahsatch Ave., Ste 305
Colorado Springs, CO 80903
(719) 955-5485**

Job. No. 18-005

EPC Project # SF XX-XXX

Revise to:
"PPR2311"
(with no dashes or extras zeros or
extra spaces in the file number)

TABLE OF CONTENTS

Table of Contents	1
General Site Description	2
Existing Site Conditions	2
Soils	2
Soil Erosion Potential	3
Phasing Plan	3
Water Quality	3
Narrative Description of BMP Control Measures	3
Timing Schedule	4
Areas of Disturbance	4
Permanent Stabilization	4
Owners Inspections and Maintenance of BMP's	5
Soils Borings / Test and Groundwater	5
Site Run-off Characteristics	5
Introduction	6
Floodplain Statement	6
Receiving Waters Descriptions	6
Existing Vegetation Description	6
Potential Pollution Sources	7
Anticipated Non-Stormwater Discharges	7
Proposed Sequence of Construction Activities	7
Structural Practices	7
Non-Structural Practices	8
Materials Handling and Spill Practices	8
Revising BMP's and SWMP	8
Selecting Post-Construction BMPs	9
Inspections	9
Record Keeping	9

APPENDICES

CDPHE Application Discussion
Vicinity Map
Grading, Erosion, Stormwater Inspection Checklist
Spill Cleanup Instructions and Report Form
BMP Construction Details
Grading and Erosion Control Plans

STORMWATER MANAGEMENT PLAN (SWMP)

General Site Description

This project sites consists of Lot 2 of the Crossroads Mixed Use Filing No. 2 (commercial development), a replat of Tract D of the Crossroads Mixed Use Fil. No. 1. The Crossroads Mixed Use Fil. No. 2 site is located north of Colorado Highway 24 and west of Colorado Highway 94, in a portion of the south half of Section 8, Township 14 South, Range 65 West of the 6th P.M., within unincorporated El Paso County, Colorado. The overall Crossroads Mixed Use Fil. No. 2 site is bound to the west by Aura at Crossroads (a Multi-family development) and Southern Rail point roadway, & to the north by Meadowbrook Crossing Fil. No. 1 (Single-family development) and Meadowbrook Parkway roadway, then to the west by Newt Drive and the south by Colorado Highway 24. Drainage flows from this site are tributary to the East Fork Sand Creek Sub tributary within the Sand Creek Drainage Basin.

Lot 2 of the Crossroads Mixed Use Filing No. 2 consists of 0.794 acres and is presently undeveloped. Lot 2 is bound to the north and east by Tracts B & C with Central Rail Point (planned private access road within the commercial development). Then to the west by Lot 1 of Crossroads Mix Use Fil No. 2 development. Tracts B & C are planned for future commercial developments and the south by existing Colorado Highway 24. The overall Crossroads Mix Use Fil. No. 2 site is currently being prepared for over-lot grading activities (the GEC plans are under review with El Paso County). The site presently exists of sparse grassy vegetation, consisting of native grasses, as determined by a site visit during the summer season. Existing site terrain generally slopes from north to southwest and north to southeast at grade rates ranging between 2% and 20%.

Land use for Lot 2 Crossroads Mixed Use Filing No. 2 is currently listed as a vacant commercial lot. Improvements proposed for the site includes commercial restaurant-style building, including drive lanes, parking lots/medians, associated site lighting, utility services, and landscaping.

Existing Site Conditions

Lot 2 of the Crossroads Mixed Use Filing No. 2 consists of 0.794 acres and is presently undeveloped. The overall Crossroads Mixed Use Filing No. 2 site is situated on the east side of the Sand Creek watershed. The overall site is currently under review for a replat of Crossroads Mixed Use Filing No. 2, a replat of Tract D of the Crossroads Mixed Use Fil. No. 1 and the overall Crossroads Mix Use Fil. No. 2 (including the Lot 2 site) is currently being prepared for over-lot grading activities (the GEC plans are under review with El Paso County).

Soils

Soils in the project area have been determined to be Blakeland Loamy Sand (8) and Blendon Sandy Loam (10), which are characterized to be part of Hydrologic Soil Types "A" & "B" as determined by the United States Department of Agriculture (USDA) Natural Resources Conservation Service (NRCS) "Web Soils Survey." A soils map illustrating the site location and soil types is provided in the appendix of this report.

Soil Erosion Potential

The proposed onsite construction activities anticipate the potential for soil erosion. Onsite stormwater BMP management facilities are proposed to minimize and aid in soil erosion. These consist chiefly of moderately deep or deep, moderately well-drained or well-drained soils that have moderately fine texture to moderately coarse texture. Group A & B soils have a moderate infiltration rate when thoroughly wet. These soils have a moderate rate of water transmission. These soils thus have a moderate potential for erosion.

Phasing Plan

However, the BMPs are phased as you have Interim and Final GEC Plans

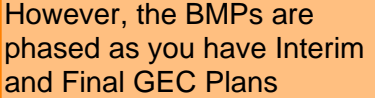

The Grading and Erosion Control Plan for Lot 2, of Crossroads Mixed Use Filing No. 2 will not be a phased project. Tracts B and C will development timing is unknown at this time but is planned as future commercial developments.

Water Quality

The permanent BMP facilities constructed will be owned and maintained by the Crossroads Development Company.

Narrative Description of BMP Control Measures

Installations of BMPs are staged in order to minimize the potential for pollutants in the stormwater discharge. A pre-construction meeting is necessary prior to commencement of BMP installation. The following stages will be used: establishment of perimeter controls, installation of temporary BMPs during soil disturbance, and then installation of permanent controls. Descriptions of some of the available BMPs are listed in below stages:

Clearing necessary for the installation of perimeter controls should be employed in the first stage of temporary BMPs installation. Silt Fence, Vehicle Tracking, and Inlet Protection should be installed as shown on the Grading & Erosion Control Plan. Locations for temporary earthwork stockpiles will also be established. Once these locations have been established, they should be added and denoted on the copy of the plan that will be kept with the site administrator. At this time, the El Paso County inspector should be notified to schedule an initial inspection.

Once temporary infrastructures have been constructed, the installation of interim temporary BMPs will commence. A Concrete Washout Area is the only interim temporary BMPs for this site.

The final stage is the installation of permanent BMPs where no further disturbance is anticipated. Upon completion of the permanent BMPs and all grading activities are completed, all disturbed areas not sodded or developed will be mulched and reseeded with native seed mix and may be watered until vegetative cover has been fully re-instated. At this point, the person responsible for inspection and maintenance can begin to address requirements for final stabilization. See construction details for installation and maintenance.

Specifically, the proposed project will use vehicle tracking control pads, stockpiles, concrete washout areas, inlet protection, silt fencing, surface roughening, and mulching and reseeding to mitigate the potential for erosion across the site.

No ground water, springs, or irrigation of non-stormwater discharge covered by CDPHE low risk guidance are known for this project.

Areas for storage of building materials, soil stockpiles or wastes are to be determined by the grading contractor and shown on the erosion control plan once determined. Construction vehicles (trucks) will access the site from Meadowbrook Parkway & Central Rail Point only. Portable toilets shall be located a minimum of 10 feet from stormwater inlets and 50 feet from state waters. They shall be secured at all four corners to prevent overturning and cleaned on a weekly basis. They will be inspected daily for spills.

There are no dedicated asphalt or concrete batch plants associated with this project.

This project does not rely on control measures owned or operated by another entity. There are no offsite stormwater control measures proposed for use by the project that are not under the direct control of the owner or contractor.

Removal of temporary control measures can be completed once the downstream drainage systems are complete, completion of upstream development, and vegetative cover has been established. See Permanent Stabilization.

Timing Schedule

Anticipated Starting and Completion Time Period of Grading Activities:

Initial Stage – Summer 2023

Substantial Completion Stage – Spring of 2024

Expected Date on which the Final Stabilization Stage will be completed: - **Fall 2024**

Removal of Temporary BMP's, (ex. Silt Fence, Inlet protection...)

Upon completion of all upstream development and 70% or more vegetation establishment of pre-disturbance levels

Areas of Disturbance

Total subject property site acreage: **0.794 AC**

Total disturbed area of subject property: **~0.794 AC**

Permanent Stabilization

Final stabilization is reached when all soil-disturbing activities at the site have been completed, and uniform vegetative cover has been established by drill seeding and crimping with a density of at least 70% of pre-disturbance levels or equivalent permanent physical erosion reduction methods have been employed. The CDPHE Water Quality Division may, after consultation with the permittee and upon good cause, amend the final stabilization criteria for specific operations. At this time, the EI

Paso County inspector should be notified to schedule a final inspection. The conditions of the SWMP and General Permit for Stormwater Discharges associated with Construction Activity will remain in effect until Final Stabilization is achieved and a notice of inactivation is sent by the applicant to CDPHE Stormwater Quality Division. All pertinent records must be kept on file for at least 3 years from the date the site is finally stabilized.

Owner Inspections and Maintenance of BMP's

1. Make thorough inspection of the stormwater management system at least every 14 days.
2. Make thorough inspection of the stormwater management system after each precipitation event that causes runoff.
3. If any deficiencies are noted, they must be corrected immediately after being noted.
4. Records of the signed site inspections or modifications must be kept at the site unless alternate place is approved by the El Paso County inspector and must be made available upon request.
5. Inspections must take place where construction activity is complete, but lot is not sold.
6. Monthly inspections must take place on site where construction activity is complete, but vegetative cover is still being established.

Soil Borings / Test and Groundwater

A Geotechnical Investigation has been completed for the Crossroads Mixed Use development, titled Soils and Geology Study, Crossroads Apartments, Parcel No. 5408007005, El Paso County, Colorado, by RMG- Rocky Mountain Group, dated August 6, 2020, revised March 3rd, 2021.

Site Runoff Characteristics

The site runoff coefficients are:	Minor Storm	Major Storm
-Historic existing Conditions	0.08	0.36
-Roofs, sidewalks, paved areas	0.90	0.96
-Landscaped and undeveloped areas	0.12	0.39

Introduction

To: Site Inspector responsible for all Colorado Department of Public Health and Environment and El Paso County Requirements:

The following stormwater management plan (SWMP) is a required item under the Construction Stormwater Discharge Permit. The primary goal for a SWMP is to improve water quality by reducing pollutants in stormwater discharges. Construction dewatering is a separate issue, and must be covered by the CDPHE Stormwater Quality Division's general permit for construction dewatering (regardless of the size of the construction project). Stormwater that mixes with ground water in an excavation is subject to the controls of a Construction Dewatering Permit. The SWMP will be completed and implemented at the time the project breaks ground, and will be revised, if necessary, as construction proceeds. This document must be kept at the construction site at all times and be made available to the public and any representative of any Water Quality Control Divisions if requested. Inspection guidance can be found at www.cdphe.state.co.us/ and El Paso County and City of Colorado Springs Storm Drainage Design Criteria. The inspections should be made at least every 14 days and after any precipitation or snowmelt event that causes surface erosion. El Paso County requires that the inspector must be contacted 48 hours prior to initial and final inspections. An inspection log entry should be completed with each inspection performed. The inspection log should be kept with the SWMP. The conditions of the SWMP and General Permit for Stormwater Discharges associated with the construction activity will remain in effect until final stabilization is achieved, and a notice of inactivation is sent to CDPHE Stormwater Quality Division. All pertinent records must be kept for at least 3 years from the date the site is stabilized or sold.

Floodplain Statement

According to the Federal Emergency Management Agency (FEMA) Flood Insurance Rate Map (FIRM) Nos. 08041C0754 G & 08041C0752 G, effective date December 7th, 2018, none of the site lies within a designated floodplain. A copy of these annotated maps can be found in the appendix. The Sand Creek East Fork Channel is located to the northwest of the adjacent Meadowbrook Crossing subdivision.

Receiving Water Description

The site is located on the east side of the Sand Creek Drainage Basin, and will reach Sand Creek from the East Fork Sand Creek Subtributary. No stream crossings are proposed for this project.

Existing Vegetation Description

Lot 2, of the Crossroads Mixed Use Filing No. 2 consists of 0.794 acres and is presently undeveloped. The overall site is currently under review for a replat of Crossroads Mixed Use Filing No. 2, a replat of Tract D of the Crossroads Mixed Use Fil. No. 1 and the overall Crossroads Mix Use Fil. No. 2 (including the Lot 2 site) is currently being prepared for over-lot grading activities (the GEC plans are under review with El Paso County). Until grading activities commence with the previously mentioned GEC plans under review) a site visit during the 2022 summer of season, and the site presently exists of sparse grassy vegetation. Existing site terrain generally slopes from north to southwest and north to southeast at grade rates ranging between 2% and 20%. Visual inspection is an acceptable method for comparison and determination of ground cover percentage.

Potential Pollution Sources

Construction activities that will take place at this site may have an impact on the stormwater quality. These include, but are not limited to, portable toilets, materials storage, vehicle fueling, maintenance and vehicle tracking, dust, waste piles, significant dust generating processes, routine maintenance activities involving fertilizers, pesticides, herbicides, detergents, fuels, solvents, oils, loading and unloading areas, dumpsters, etc... The location of any of these activities not included on the initial site map should be added, along with a description of the measures used to prevent the discharge of these materials from the site. See construction details for installation and maintenance. All trash and debris should be removed from the site on a regular basis and disposed of properly.

Anticipated Non-Stormwater Discharges

Non-stormwater discharges are caused by activities other than direct runoff from precipitation events. These include, but are not limited to natural springs, irrigation. Any non-stormwater discharges that are not included in the initial map should be added along with a description of measures used to handle it. There are no known natural springs, temporary or permanent irrigation that would cause erosion on this project site.

Proposed Sequence of Construction Activities

1. Notify the inspector for initial inspection.
2. Clearing for necessary for perimeter controls.
3. Construct vehicle traffic control pad at entrance/exit of construction site.
4. Install lot perimeter controls, including silt fence, delineating project site as indicated on Site Map.
5. Complete remaining clearing and grubbing for project area. Install additional BMPs, as indicated on Site Map.
6. Final grade site as indicated on Site Map.
7. Achieve Final Stabilization, as outlined in SWMP. Send inactivation notice to CDPHE.
8. See Construction Details for BMP Installation and Maintenance.

Any stockpile areas are to be contained with silt fence, or other acceptable measures to prevent erosion and sediment from leaving the area. All BMP's that may be in place need to be inspected and cleaned if sediment should leave the site and enter the streets. Erosion control measures shall be implemented in a manner that will protect properties and public facilities from the adverse effect of erosion and sedimentation as a result of construction and earthwork activities. The following practices are to be implemented for this site:

Structural Practices

A vehicle traffic control pad will be installed at the entrance/exit of the site to reduce sediment tracking off-site. Practices may include, but are not limited to: straw bales, wattles/sediment control logs, silt fences, earth dikes, drainage swales, sediment traps, subsurface drains, pipe slope drains, and temporary or permanent sediment basins. All roads will be inspected to ensure that sediment from on-site construction activity is not being discharged with the stormwater. Sediment and debris that have been tracked off site should be removed daily by shoveling or sweeping. See construction details for installation and maintenance.

Non-Structural Practices

Surface roughening may be used to reduce the amount of runoff and wind erosion from any given areas. Once the existing vegetation is cleared, watering should occur to help control fugitive dust. Disturbed areas where work is temporarily halted shall be temporarily stabilized within 21 calendar days after activity has ceased unless work is to be resumed within 30 calendar days after the activity has ceased. Other Non-Structural Practices may include soils erosion control measures for all slopes, channels, ditches, or any disturbed land area and shall be completed within 21 calendar days after final grade, or final earth disturbance, has been completed. Disturbed areas and stockpiles, which are not at final grade but will remain dormant for longer than 30 days, shall also be mulched within 21 days after interim grading. An area that is going to remain in an interim state for more than 60 days shall also be seeded. All temporary soil erosion control measures and BMPs shall be maintained until permanent soil erosion control measures are implemented. See construction details for installation and maintenance.

Materials Handling and Spill Practices

Any substances with potential to contaminate either the ground or ground surface water shall be cleaned up immediately after discovery or contained until appropriate cleanup methods can be employed. Manufacturer's recommended methods for cleanup shall be followed, along with proper disposal methods. Any discharge of hazardous materials must be handled in accordance with the Divisions Notification Requirement. All waste and debris created by construction activities at the site or removed from the site shall be disposed of in compliance with all laws, regulations and ordinances of the federal, state and local agencies. See construction details for Materials Handling and Spills.

Revising BMP's and SWMP

1. The plans must be amended, by the contractor whenever there is a change in design, construction operation or maintenance that could have a significant effect on the potential for the discharge of pollutants to State Waters. It also must be amended if it is found to be ineffective in controlling pollutants present in stormwater.

2. Permittees are required to amend, adapt, and adjust their SWMP to accurately reflect phased construction changes and current conditions at the site. Plan modifications are broken into major and minor modifications which have differing requirements.

Major Modifications: Major modifications are changes to the SWMP that remove or add area to the project, modify the final hydrology or drainage of the final design, replace approved SWMP, or otherwise expand or contract the scope of the approved project. A revised SWMP and any revised supporting documents require review and approval of the local agency.

Minor Modifications: Minor modifications are changes to the SWMP that do not increase the scope or change hydrology of the project but; modify or improve specific BMPs in use at the site, indicate progression in phasing of the project, or specify relocation of previously approved BMPs within the project. Minor modifications can be made in the field by the permittee if the permittee can demonstrate that the modified soil erosion controls are equivalent to, or better than, the originally approved BMPs. Minor modifications must be thoroughly documented in the permittee's SWMP narrative, drawings and specifications.

3. The SWMP should be viewed as a "living document" throughout the lifetime of the project.
4. The plan must be signed in accordance with the general permit.

5. The plan must be made available, upon request, to CDPHE, United States Environmental Protection Agency, or operator of the local municipal storm sewer system, if applicable.

6. The following documents must be kept in a field office, trailer, shed, or vehicle that is onsite during normal working hours;
 1. The permit coverage letter from the Colorado Department of Public Health and Environment (CDPHE)
 2. The Stormwater Management Plan
 3. Site Inspection Records
 4. A copy of the Colorado General Permit for Stormwater Discharges from Construction Activities.

Selecting Post-Construction BMPs

Post Construction BMPs; Revegetation including seeding and mulching will be the final BMP's. Permanent stabilization will be achieved with 70% vegetative establishment.

Inspections

Inspections should occur at least every 14 days and within 24 hours of a rainfall event producing runoff, usually this occurs with precipitation of 1/4 inch of rain or more. The local news weathers report gives general rainfall amounts each day.

The inspection schedule should be routinely accomplished every 14 days and within 24 hours of the end of a storm event for the entire site with all BMP's evaluated for performance and need. Any BMP found to be ineffective should be re-accomplished or replaced with a new BMP to provide the level of protection needed. BMP's found to be no longer needed can be removed. Inspections should also be accomplished as soon as practical, at the end of a rain event causing surface erosion. The general procedure for correcting problems when identified should be documented in a log and a solution to correct the problem as soon as possible. The QSM will be sufficiently qualified for the required duties per the ECM Appendix I.5.2.A.

Record Keeping

Records should be retained for a minimum period of at least 3 years after the permit is terminated. Sign and date the inspection log sheets provided in the Appendix of this report. The inspection logs and location of SWMP records should be kept onsite.

APPENDICES

CDPHE APPLICATION

The Stormwater Discharge Associated with Construction Activities Application must be obtained and submitted by the owner, contractor, individual, or entity that is deemed as the Permit Operator for Crossroads Mixed Use at the time of construction.

VICINITY MAP

VICINITY MAP

LOT 2 - CROSSROADS MIXED USE FILING NO. 2



SCALE 1"=300'

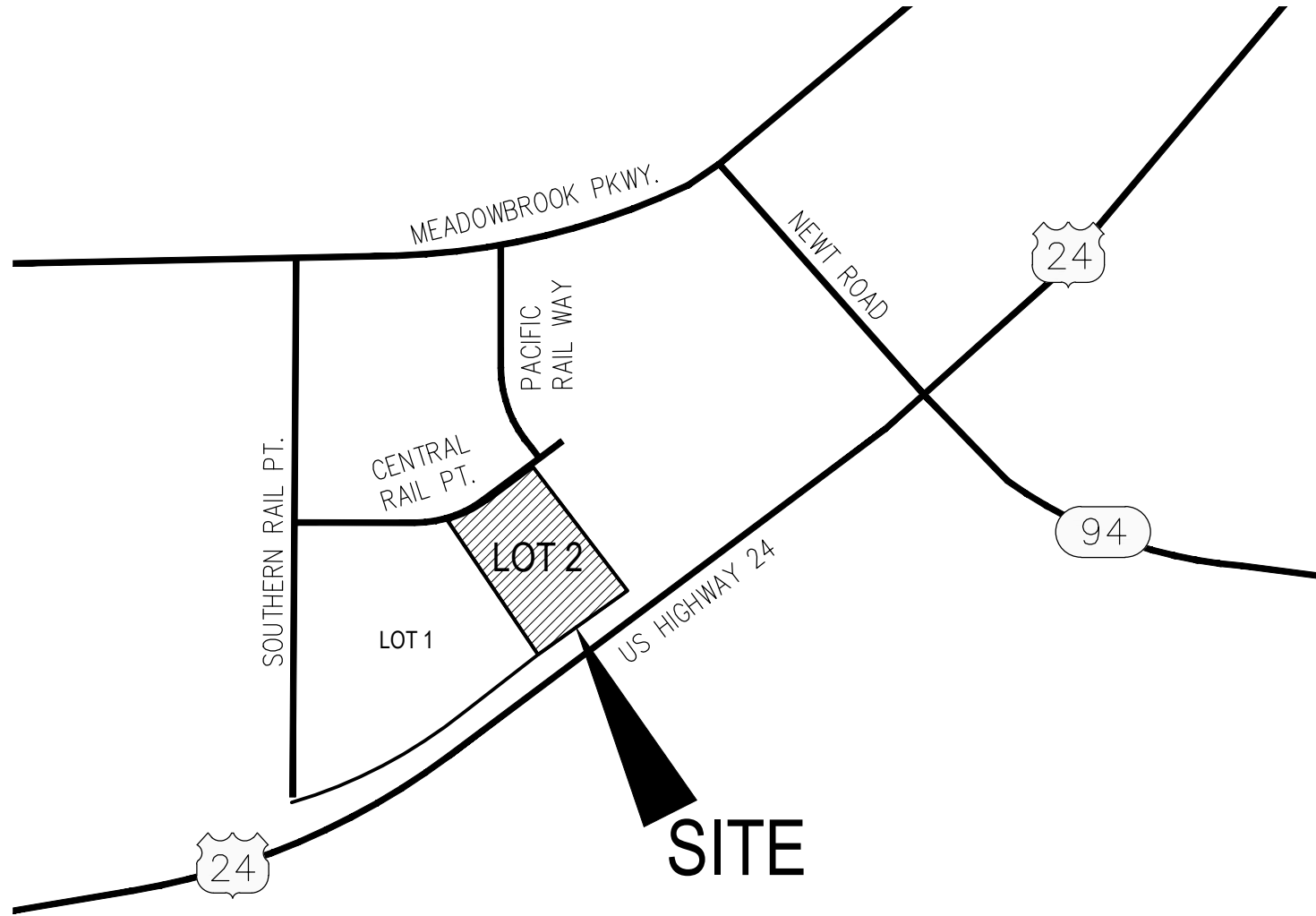

LOT 2 - CROSSROADS MIXED
USE FILING NO. 2
VICINITY MAP
JOB NO. 18-005
DATE PREPARED: 1/23/2023

**GRADING, EROSION, STORMWATER
INSPECTION CHECKLIST**

Appendix C Inspection Checklist – Grading Erosion, and Stormwater Quality Controls

CITY OF COLORADO SPRINGS

DATE/TIME:
INSPECTOR:
TYPE OF INSPECTION: Self-Monitoring_____
Initial _____ Compliance_____ Follow-Up_____
Reconnaissance_____ Complaint_____ Final_____

SITE:	DATE OF PERMIT:
ADDRESS:	
CONTRACTOR:	OWNER/OWNER'S REPRESENTATIVE:
CONTACT:	CONTACT:
PHONE:	PHONE:
STAGE OF CONSTRUCTION: Initial BMP Installation/Prior to Construction_____ Clearing & Grubbing_____	
Rough Grading_____ Finish Grading_____ Utility Construction_____ Building Construction_____	
Final Stabilization_____	

OVERALL SITE INSPECTION	YES/NO/N.A.	REMARKS/ACTIONS
Is there any evidence of sediment leaving the construction site? If so, note areas.		
Have any adverse impacts such as flooding, structural damage, erosion, spillage, or accumulation of sediment, debris or litter occurred on or within public or private property, wetlands or surface waters –to include intermittent drainageways and the City's stormwater system (storm sewers, gutters, ditches, etc.)?		
Are the BMPs properly installed and maintained?		
Have the BMPs been placed as shown on approved plans?		
Are the BMPs functioning as intended?		
Is work being done according to approved plans and any phased construction schedule?		
Is the construction schedule on track?		
Are drainage channels and outlets adequately stabilized?		
Is there any evidence of discharges or spills of fuels, lubricants, chemicals, etc.?		

BMP MAINTENANCE CHECKLIST	YES/NO/N.A.	REMARKS/ACTIONS NECESSARY
<p>SURFACE ROUGHENING</p> <p>Is the roughening consistent/uniform on slopes??</p> <p>Any evidence of erosion?</p>		
<p>TEMPORARY SEEDING</p> <p>Are the seedbeds protected by mulch?</p> <p>Has any erosion occurred in the seeded area?</p> <p>Any evidence of vehicle tracking on seeded areas?</p>		
<p>TEMPORARY SWALES</p> <p>Has any sediment or debris been deposited within the swales?</p> <p>Have the slopes of the swale eroded or has damage occurred to the lining?</p> <p>Are the swales properly located?</p>		
<p>VEHICLE TRACKING</p> <p>Is gravel surface clogged with mud or sediment?</p> <p>Is the gravel surface sinking into the ground?</p> <p>Has sediment been tracked onto any roads and has it been cleaned up?</p> <p>Is inlet protection placed around curb inlets near construction entrance?</p>		
<p>OTHER</p>		

FINAL INSPECTION CHECKLIST	YES/NO/N.A.	REMARKS/ACTIONS NECESSARY
Has all grading been completed in compliance with the approved Plan, and all stabilization completed, including vegetation, retaining walls or other approved measures?		
Has final stabilization been achieved – uniform vegetative cover with a density of at least 70 percent of pre-disturbance levels, and cover capable of adequately controlling soil erosion; or permanent, physical erosion methods?		
Have all temporary measures been removed?		
Have all stockpiles, construction materials and construction equipment been removed?		
Are all paved surfaces clean (on-site and off-site)?		
Has sediment and debris been removed from drainage facilities (on-site and off-site) and other off-site property, including proper restoration of any damaged property?		
Have all permanent stormwater quality BMPs been installed and completed?		

ADDITIONAL COMMENTS:
--

The items noted as needing action must be remedied no later than _____.

The contractor shall notify the inspector when all the items noted above have been addressed.

By signing this inspection form, the owner/owner's representative and the contractor acknowledge that they have received a copy of the inspection report and are aware it is their responsibility to take corrective actions by the date noted above. Failure to sign does not relieve the contractor and owner/owner's representative of their responsibility to take the necessary corrective action and of their liability for any damages that have occurred or may occur.

INSPECTOR'S SIGNATURE:	DATE:
OWNER/OWNER'S REPRESENTATIVE SIGNATURE:	DATE:
CONTRACTOR'S SIGNATURE:	DATE:

SPILL CLEANUP INSTRUCTIONS AND REPORT FORM

involving a radioactive or infectious material, or there is a release of a marine pollutant.

Spills and incidents that have or may result in a spill along a highway must be reported to the nearest law enforcement agency immediately. The Colorado State Patrol and CDPHE must also be notified as soon as possible. In the event of a spill of hazardous waste at a transfer facility, the transporter must notify CDPHE within 24 hours if the spill exceeds 55 gallons or if there is a fire or explosion.

The National Response Center should be notified as soon as possible after discovery of a release of a hazardous liquid or carbon dioxide from a pipeline system if a person is killed or injured, there is a fire or explosion, there is property damage of \$50,000 or more, or any nearby water body is contaminated.

The National Response Center and the Colorado Public Utilities Commission Gas Pipeline Safety Section must be notified as soon as possible, but not more than two hours after discovery of a release of gas from a natural gas pipeline or liquefied natural gas facility if a person is killed or injured, there is an emergency shutdown of the facility, or there is property damage of \$50,000 or more. The Colorado Public Utilities Commission should also be notified if there is a gas leak from a pipeline, liquefied natural gas system, master meter system or a propane system that results in the evacuation of 50 or more people from an occupied building or the closure of a roadway.

Oil and Gas Exploration

All Class I major events on federal lands, including releases of hazardous substances in excess of the CERCLA reportable quantity and spills of more than 100 barrels of fluid and/or 500 MCF of gas released, must be reported to the Bureau of Land Management (BLM) immediately. Spills of oil, gas, salt water, toxic liquids and waste materials must also be reported to the BLM and the surface management agency.

Spills of exploration and production (E&P) waste on state or private lands in excess of 20 barrels, and spills of any size that impact or threaten to impact waters of the state, an occupied structure, or public byway must be reported to the Colorado Oil and Gas Conservation Commission as soon as practicable, but not more than 24 hours after discovery. Spills of any

size that impact or threaten to impact waters of the state must be reported to CDPHE immediately. Spills that impact or threaten to impact a surface water intake must be reported to the emergency contact for that facility immediately after discovery. Spills of more than five (5) barrels of E&P waste must be reported in writing to the Oil and Gas Conservation Commission within 10 days of discovery.

REPORTING NUMBERS

National Response Center (24-hour)
1-800-424-8802

CDPHE Colorado Environmental Release and Incident Reporting Line (24-hour)
1-877-518-5608

Radiation Incident Reporting Line (24-hour)
303-877-9757

Colorado State Patrol (24-hour)
303-239-4501

Division of Oil and Public Safety
(business hours)
303-318-8547

Oil and Gas Conservation Commission
(business hours)
303-894-2100

Colorado Public Utilities Commission Gas Pipeline Safety Section (business hours)
303-894-2851

Local Emergency Planning Committees
(to obtain list, business hours)
720-852-6603



Colorado Department
of Public Health
and Environment

Environmental Spill Reporting

Colorado Department of Public
Health and Environment
4300 Cherry Creek Drive South
Denver, CO 80246-1530

<http://www.cdphpe.state.co.us>

January 2009

When a release of a hazardous material or other substance occurs to the environment, there are a number of reporting and notification requirements that must be followed by the company or individual responsible for the release. Most spills are covered by more than one reporting requirement, and **all** requirements must be met. In addition to verbal notification, written reports are generally required. This brochure briefly explains the major requirements. A more detailed description is provided in the "Reporting Environmental Releases in Colorado" Guidance Document, available on the web.

Releases that must be reported to the Colorado Department of Public Health and Environment (CDPHE) may be reported to the Colorado Environmental Release and Incident Reporting Line.

ENVIRONMENTAL SPILL REPORTING

CERCLA, EPCRA and RCRA

The Comprehensive Environmental Response, Compensation and Liability Act (CERCLA) and the Emergency Planning and Community Right-to-Know Act (EPCRA) require that a release of a reportable quantity or more of a hazardous substance to the environment be reported immediately to the appropriate authorities when the release is discovered.

Under CERCLA, reportable quantities were established for hazardous substances listed or designated under other environmental statutes. These include:

- all hazardous air pollutants (HAPs) listed under Section 112(b) of the Clean Air Act.
- all toxic pollutants designated under Section 307(a) or Section 311(b)(2)(A) of the Clean Water Act.
- all Resource Conservation and Recovery Act (RCRA) characteristic and listed hazardous wastes.
- any element, compound, or substance designated under Section 102 of CERCLA.

EPCRA established a list of extremely hazardous substances (EHS) that could cause serious irreversible health effects from accidental releases. Many substances appear on both the CERCLA and EPCRA lists. EPCRA extremely hazardous substances that are also CERCLA hazardous substances have the same reportable quantity (RQ) as under CERCLA. EPCRA extremely hazardous substances that are not listed under CERCLA have a reportable quantity that is equal to their threshold planning quantity (TPQ). A list of CERCLA reportable quantities is included in 40 CFR Section 302.4. A list of EPCRA threshold planning quantities is included in 40 CFR Part 355 Appendices A & B.

CERCLA-reportable releases must be reported immediately to the National Response Center (NRC), while EPCRA-reportable releases must be reported immediately to the National Response Center, the State Emergency Response Commission (SERC) and the affected Local Emergency Planning Committee (LEPC). If the release is an EPCRA extremely

hazardous substance, but not a CERCLA hazardous substance, and there is absolutely no potential to affect off-site persons, then only the State Emergency Planning Commission (represented by CDPHE for reporting purposes) and the Local Emergency Planning Committee need to be notified.

In the case of a release of hazardous waste stored in tanks, RCRA-permitted facilities and large quantity generators must also notify CDPHE within 24 hours of any release to the environment that is greater than one (1) pound.

Radiation Control

Each licensee or registrant must report to the Radiation Incident Reporting Line in the event of lost, stolen or missing licensed or registered radioactive materials or radiation machines, releases of radioactive materials, contamination events, and fires or explosions involving radioactive materials. Releases of radionuclides are reportable under CERCLA.

Clean Water Act

The Clean Water Act requires the person in charge of a facility or vessel to immediately report to the National Response Center all discharges of oil or designated hazardous substances to water. Oil means oil of any kind or form. Designated hazardous substances are included in the CERCLA list.

The Clean Water Act also requires that facilities with a National Pollutant Discharge Elimination System (NPDES) permit report to the National Response Center within 24 hours of becoming aware of any unanticipated bypasses or upsets that cause an exceedance of the effluent limits in their permit and any violations of their maximum daily discharge limits for pollutants listed in their permit.

A release of any chemical, oil, petroleum product, sewage, etc., which may enter waters of the state of Colorado (which include surface water, ground water and dry gullies and storm sewers leading to surface water) must be reported immediately to CDPHE. Any accidental discharge to the sanitary sewer system must be reported immediately to the local sewer authority and the affected wastewater treatment plant. For additional reporting releases to water, please see "Guidance for Reporting Spills under the Colorado

Water Quality Control Act and Colorado Discharge Permits" at <http://www.cdphe.state.co.us/op/wqcc/Resources/Guidance/spillage.pdf>.

Clean Air Act

Hazardous air pollutants (HAPs) are designated as hazardous substances under CERCLA. If a facility has an air permit but the permit does not allow for or does not specify the release of a substance, or if the facility does not have an air permit, then all releases in excess of the CERCLA / EPCRA reportable quantity for that substance must be reported to the National Response Center and CDPHE. If the facility releases more of a substance than is allowed under its air permit, the facility must also report the release. Discharges of a substance that are within the allowable limits specified in the facility's permit do not need to be reported.

Regulated Storage Tanks

Owners and operators of regulated storage tank systems must report a release or suspected release of regulated substances to the Division of Oil and Public Safety at the Colorado Department of Labor and Employment within 24 hours. Under this program, the reportable quantity for petroleum releases is 25 gallons or more, or any amount that causes a sheen on nearby surface water. Spills of less than 25 gallons of petroleum must be immediately contained and cleaned up. If cleanup cannot be accomplished within 24 hours, the Division of Oil and Public Safety must be notified immediately.

Spills of hazardous substances from tanks in excess of the CERCLA or EPCRA reportable quantity must be reported immediately to the National Response Center, CDPHE and the local fire authority, and to the Division of Oil and Public Safety within 24 hours.

Transportation and Pipelines

The person in physical possession of a hazardous material must notify the National Response Center as soon as practical, but not to exceed 12 hours after the incident, if as a direct result of the hazardous material, a person is killed or injured, there is an evacuation of the general public lasting more than an hour, a major transportation artery is shut down for an hour or more, the flight pattern of an aircraft is altered, there is fire, spillage or suspected contamination

WATER QUALITY
CONTROL
DIVISION

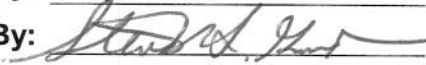
Policy No: WQE-10
Initiated By: Dave Akers
Approved By: 
Effective Date: 3/1/08
Revision No.: _____
Revision Date: _____

**Guidance for Reporting Spills under the Colorado Water Quality
Control Act and Colorado Discharge Permits**

I. Purpose

To provide guidance on applicable Colorado reporting requirements pursuant to § 25-8-601(2), C.R.S., that pertains to spills or discharges that may cause pollution of State waters. This guidance does not relieve an entity of any other statutory or regulatory requirements applicable to a spill. Facilities possessing a Colorado Discharge Permit System (CDPS) permit should follow applicable permit terms and conditions regarding spill reporting and response. This guidance is not intended to supersede or modify such permit terms and conditions or the applicable statute and regulations. This guidance does not limit the existing rights or responsibilities of persons with respect to spill reporting. For example, persons retain the right and responsibility to determine in the first instance whether a particular spill is covered by an existing permit or may cause pollution to State waters (i.e., surface or ground waters).

II. Statutory Requirement Addressed

Colorado Water Quality Control Act - Spill Reporting Requirements - § 25-8-601(2), C.R.S.

“Any person engaged in any operation or activity which results in a spill or discharge of oil or other substance which may cause pollution of the waters of the state contrary to the provisions of this article as soon as he has knowledge thereof, shall notify the division of such discharge.”

State waters means any and all surface and subsurface waters which are contained in or flow in or through this state, but does not include waters in sewage systems, waters in treatment works of disposal systems, waters in potable water distribution systems, and all water withdrawn for use until use and treatment have been completed (§ 25-8-103 (19), C.R.S.).

Examples of State waters include, but are not limited to, perennial streams, intermittent or ephemeral gulches and arroyos, ponds, lakes, reservoirs, irrigation canals or ditches, wetlands, stormwater conveyances (when they discharge to a surface water), and groundwater.

III. Policy/Applicability

The Division distinguishes between reporting requirements for spills that occur with respect to activities that result in a discharge that is authorized under a CDPS permit and those that are not. For non-permitted activities, or in the case of an activity where a permit does not address reporting of or response to a given spill, the Division recommends that the responsible person(s) take the following actions:

1. Immediately report spills that may result in a non-permitted discharge of pollutants to State waters to the Environmental Release and Incident Reporting Line at 1-877-518-5608;
2. Include the following information, if available, when notifying the Division of a spill:
 - a. The name of the responsible person and, if not reported by that person, the name of the person reporting the spill and the name of the responsible person if known;
 - b. An estimate of the date and time that the spill began or the actual date and time, if known;

- c. The location of the spill, its source (e.g., manhole, tanker truck), and identification of the type of material spilled (e.g., untreated wastewater, biosolids, specific chemical);
- d. The estimated volume of the spill and, if known, the actual date and time the spill was fully controlled/stopped.
- e. Whether the spill is ongoing and, if it is, the rate of flow and an estimate of the time that the spill will be fully controlled, if known;
- f. Measures that are being or have been taken to contain, reduce, and/or clean up the spill;
- g. A list of any potentially affected area and any known downstream water uses (e.g., public water supplies, irrigation diversions, public use areas such as parks or swim beaches) that will be or have been notified; and
- h. A phone number and e-mail to contact a representative of the responsible person that is in charge of the response. Where a non-responsible person is reporting the spill, they are encouraged, but not required, to provide contact information.

Reporting and management of spills that occur with respect to activities resulting in a discharge authorized under a permit should be performed in accordance with the specific requirements of that permit. If the permit does not provide specific reporting or management response requirements for a given spill that may pollute State waters, the Division recommends that the responsible person report the spill in accordance with the procedures listed above.

This guidance only addresses reporting requirements under the Division's authority. The person or entity engaged in any operation or activity that results in a spill is responsible for any other applicable reporting requirements associated with the spill to other regulatory agencies.

Section 25-8-601(2), C.R.S. only addresses spill reporting to the Division. Section 25-8-202(7), C.R.S. provides certain water quality responsibilities to other state "implementing agencies." The Division's position is that, where a spill to the ground that may impact ground water only is fully and timely reported to an implementing agency having jurisdiction over that spill, the intent of section 601(2) has been fulfilled, and the spill need not also be reported to the Division. The Division suggests that the responsible person confirm with the implementing agency that a spill falls under the jurisdiction of the implementing agency at the time it is reported in order to avoid possible legal liability should it fall under the Division's jurisdiction.

IV. Division Examples of Non-Reportable Spills

The Division has identified the following examples of types of spills that are considered "non-reportable" under § 25-8-601(2), C.R.S. Documentation of such spills, including the information listed in section III.2.a – III.2.f above, should be maintained by the responsible person for Division review for a period of three years.

1. A spill to a generally impervious surface or structure (e.g., paved street/parking lot, storm sewer, warehouse floor, manhole, vault, concrete basement), or onto soils, that is fully contained in/on the impervious surface/structure or soils, or that is managed in a manner so that it will not reach State waters at the time of the spill or in the future. Such spills that are cleaned up within 24 hours will be considered by the Division to have no potential to reach State waters. However, even if such spills are not cleaned up within 24 hours, the responsible person may be able to "fully contain" or otherwise manage a spill such that it will not reach State waters. Where there is a sump pump present in a basement to which a spill occurred, the responsible person must establish that the pump did not discharge to State waters during the time between the start of the spill and the completion of clean-up in accordance with best management practices.
2. A spill or discharge that is managed consistent with best management practices that are established in accordance with a CDPS discharge permit or any Water Quality Control Commission-adopted control regulation related to spill management or reporting.
3. A spill of potable water from a public water system that does not reach surface waters.

<input checked="" type="checkbox"/> Field Services - Grand Junction 222 South 6th Street, Room 232 Grand Junction, CO 81501 Telephone: 970-248-7150 Fax: 970-248-7198 Contact email: michelle.thiebaud@state.co.us	<input type="checkbox"/> Field Services - Pueblo 140 Central Main, Suite 300 Pueblo, CO 81003 Telephone: 719-295-5060 Fax: 719-543-8441 Contact email: carol.keever@state.co.us	<input type="checkbox"/> Field Services - Denver 4300 Cherry Creek Dr. South, B2 Denver, Colorado 80246-1530 Phone: 303-692-3650 Fax: 303-782-0390 Contact email: annemarie.goolsby@state.co.us
---	---	--

Reporting Form: Incident / Spill / Sanitary Sewer Overflow (SSO)

The Water Quality Control Division distinguishes between reporting requirements for spills that occur with respect to activities that result in a discharge that is authorized under a CDPS permit and those that are not. Reporting and management of spills that occur with respect to activities resulting in a discharge authorized under a permit should be performed in accordance with the specific requirements of that permit. If the permit does not require a 5-day report, please provide the information below in writing. For non-permitted activities, or in the case of an activity where a permit does not address reporting of or response to a given spill, please submit this written response to the Water Quality Control Division within five (5) working days of the date of the event. If sufficient space is not provided, please attach other sheets. Please send the completed form with signature via fax or email to the Division's Field Services office indicated above. If you have any questions please contact the Division's Field Services Engineer at your earliest convenience. The Field Services County list is available at: <http://www.colorado.gov/cdphe/wqcd> (Contacts, Inspection services contacts, then Field services contacts).

Prior to the five (5) working day deadline, you may request an extension to submit the report if sample analyses justifiably are going to require more time to analyze than the reporting time allows. To request an extension please send an email to the Division's Field Services Engineer for the County that the incident / spill / SSO took place or to the email listed above.

Incident Background Information			
County			
Incident / Spill Number (Division provided) and Spill Date			
Type of Incident / Spill / SSO (check one)	<input type="checkbox"/> Sanitary Sewer Overflow/Reuse	<input type="checkbox"/> Petroleum Product	<input type="checkbox"/> Chemical
	<input type="checkbox"/> WW Treatment Plant Bypass or Upset (through an authorized outfall point)	<input type="checkbox"/> WW Treatment Plant Spill or Overflow (other than outfall)	<input type="checkbox"/> Biosolids
	<input type="checkbox"/> Unplanned potable water release (e.g., water line break)		<input type="checkbox"/> Other
Contact Information			
Potentially Responsible Party (PRP): Contact Name		Potentially Responsible Party (PRP): Company / Agency	
PRP Phone / Fax	Phone: Fax:	PRP email address	
CDPS Permit Number:		CDPS Permittee Name:	
Reported by (if not PRP): Contact Name		Reported by (if not PRP): Company / Agency	
Reported by (if not PRP): Phone / Fax	Phone: Fax:	Reported by (if not PRP): email address	
Incident Information: Please provide the following information.			
A	Incident / spill / SSO source, cause, and event description.		
	Response:		
B	Material released (e.g., untreated wastewater, biosolids, specific chemicals or products) and estimated total quantity (e.g., gallons). Please attach MSDS for any and all chemicals or products involved in spill or release.		
	Response:		
C	Actual or estimated dates and times of the event, including duration and actual date and time spill was fully controlled/stopped. If release is still occurring, the date and time the release is expected to be stopped.		
	Response:		

D	Location of release (e.g., address, lat/long, road name and mile marker).
	Response:
E	Describe measures taken or planned to contain, reduce, and clean up spill or release.
	Response:
F	Steps taken or planned to prevent reoccurrence of the event.
	Response:
Incident Impact to State Waters (As defined in § 25-8-103(19), C.R.S.). <i>Examples of State waters include: perennial streams, intermittent or ephemeral gulches, ditches, ponds, lakes, reservoirs, irrigation canals, wetlands, stormwater conveyances (when they discharge to surface water), and groundwater.</i>	
G	Did flow or materials reach surface waters of the State? If so, please describe the path of flow to State waters and which State water body was impacted (e.g., spill impacted a storm drain which was directly connected to Cherry Creek, Colorado River, etc.). If yes, what quantity of material (e.g., gallons) reached the surface water and what was the resulting impact?
	Response:
H	Were any water quality samples or other samples taken? If so, please describe sampling process and attached results.
	Response:
I	Did flow or materials reach groundwater of the State? If so, please describe the path of flow to State waters and which State water body impacted (e.g., spill soaked into ground and wet soil was not excavated). If yes, what quantity of material (e.g., gallons) reached the ground or groundwater and what was the resulting impact?
	Response:
J	Did the incident include any of the following (check if yes)? If so, please include additional details below.
	<input type="checkbox"/> Toxic Chemical Release <input type="checkbox"/> Fish Kill
	Response:
Incident Impact to Areas or Water Users	
K	Did the incident / spill / SSO impact any areas (e.g., public use areas including parks or swim beaches) or downstream water users (e.g., public water suppliers, irrigation diversions)? Please list impacted areas and/or users, their location, and potential impacts.
	Response:
L	How were the impacted area users (e.g., park patrons) and downstream water users notified (e.g., signs posted, list downstream users contact via phone).
	Response:

I hereby certify that the information presented above is accurate and complete.			
Date	Company	Typed Name and Title	Signature

BMP CONSTRUCTION DETAILS

Description

Spills and leaks of solid and liquid materials processed, handled or stored outdoors can be a significant source of stormwater pollutants. Spilled substances can reach receiving waters when runoff washes these materials from impervious surfaces or when spills directly enter the storm sewer system during dry weather conditions.

Effective spill control includes both spill prevention and spill response measures and depends on proper employee training for spill response measures and may also include structural spill containment, particularly at industrial locations. Structural spill containment measures typically include temporary or permanent curbs or berms that surround a potential spill site. Berms may be constructed of concrete, earthen material, metal, synthetic liners, or other material that will safely contain the spill. Spill control devices may also include valves, slide gates, or other devices that can control and contain spilled material before it reaches the storm sewer system or receiving waters.



Photograph SPCC-1. Use of secondary containment around supplies stored outside helps to reduce the likelihood of spill and leaks reaching the storm sewer system in runoff. Photo courtesy of Tom Gore.

Appropriate Uses

Implement spill prevention, containment and control measures at municipal, commercial and industrial facilities in areas where materials may be spilled in quantities that may adversely impact receiving waters when discharged directly or through the storm sewer system. Check local, state, and/or federal regulations to determine when spill containment and control measures are required by law. Spill Prevention, Control and Countermeasures Plans may be required for certain facilities handling oil and hazardous substances under Section 311(j)(1)(C) of the federal Clean Water Act.

Practice Guidelines

Spill Prevention Measures

- Train employees on potential sources of pollution on-site and provide clear, common-sense spill prevention practices. Require that these practices be strictly followed.
- Identify equipment that may be exposed to stormwater, pollutants that may be generated and possible sources of leaks or discharges.
- Perform regular inspection and preventative maintenance of equipment to ensure proper operation and to check for leaks or evidence of discharge (stains). Provide clear procedures to ensure that needed repairs are completed and provide temporary leak containment until such repairs can be implemented.

Also See These BMP Fact Sheets

- Covering Storage/Handling Areas
- Good Housekeeping
- Vehicle Fueling, Maintenance, Washing & Storage
- Preventative Maintenance

S-2 Spill Prevention, Containment and Control

- Drain or replace motor oil and other automotive fluids in a designated area away from storm sewer inlets. Collect spent fluids and recycle or dispose of properly. Never dispose of these fluids in the storm sewer or sanitary sewer.
- In fueling areas, clean up spills with dry methods (absorbents) and use damp cloths on gas pumps and damp mops on paved surfaces. Never use a hose to “wash down” a fuel spill.
- Where practical, reduce stormwater contact with equipment and materials by implementing indoor or covered storage, implementing stormwater run-on control measures and following good housekeeping practices.

Identification of Spill Areas

Identify potential spill areas, potential spill volumes, material types, frequency of material use, and drainage paths from spill areas with relation to storm sewer inlets, adjacent waterbodies, structural BMPs, and containment structures. Use this information to determine the types of spill prevention and control measures needed specific to the site conditions. Examples of potential spill locations include:

- Loading and unloading areas
- Outdoor storage areas
- Outdoor manufacturing or processing activities
- Waste disposal/storage areas
- Areas that generate significant dust or particulates (that may be subsequently deposited on the ground)
- Salt piles
- Areas prone to spills based on past experience at the site
- Locations where other routine maintenance activities occur such as equipment maintenance and cleaning, pesticide/fertilizer application, etc.

Additionally, areas where smaller leaks may occur such as parking should also have basic spill cleanup procedures.

Material Handling Procedures

From a water quality perspective, the primary principle behind effective material handling practices is to minimize exposure to stormwater. This can be accomplished by storing the material indoors under weather-resistant covering, elevating the material off the ground by using pallets, and diverting stormwater around materials storage areas. Representative outdoor materials handling procedures include:

- Keep bulk solid materials such as raw materials, sand, gravel, topsoil, compost, concrete, packing materials, metal products and other materials covered and protected from stormwater.
- When practical, store materials on impermeable surfaces.
- Store hazardous materials according to federal, state, and local hazardous materials requirements.

- Adopt procedures that reduce the chance of spills or leaks during filling or transfer of materials.
- Substitute less toxic or non-toxic materials for toxic materials.
- Store containers that are easily punctured or damaged away from high traffic areas (i.e., adopt a materials flow/plant layout plan).
- Add waste-capture containers such as collection pans for lubricating fluids.
- Store drums and containers with liquid materials on impermeable surfaces and provide secondary containment where appropriate. Drums stored outdoors should be located on pallets to minimize contact with runoff.

Spill Response Procedures and Equipment

Spill response procedures should be tailored to site-specific conditions and industry-specific regulatory requirements. General spill response procedures include:

- Containment and cleanup of spills should begin promptly after the spill is observed.
- Sweep up small quantities of dry chemical or solids to reduce exposure to runoff. Shoveling may be used for larger quantities of materials.
- Absorbents should be readily accessible in fueling areas or other areas susceptible to spills.
- Wipe up small spills with a shop rag, store shop rags in appropriate containers, dispose of rags properly or use a professional industrial cleaning service.
- Contain medium-sized spills with absorbents (e.g., kitty litter, sawdust) and use inflatable berms or absorbent “snakes” as temporary booms for the spill. Store and dispose of absorbents properly. Wet/dry vacuums may also be used, but not for volatile fluids.
- Develop procedures and locations for containing and storing leaking containers.
- Install drip pans below minor equipment leaks and properly dispose of collected material until a repair can be made.
- For large spills, first contain the spill and plug storm drain inlets where the liquid may migrate off-site, then clean up the spill.
- Excavation of spill areas to removed contaminated material may be required where large liquid spills occur on unpaved surfaces.
- An inventory of cleanup materials should be maintained onsite and strategically located based on the types and quantities of chemicals present.

Structural Spill Containment Measures

Two general approaches are often used when implementing spill containment measures. The first approach is designed to contain the entire spill. The second approach uses curbing to route spilled material to a collection basin. Both containment berming and curbing should be sized to safely contain or convey to a collection basin a spill from the largest storage tank, rail car, tank truck, or other containment device in the possible spill area. The spill containment area must have an impermeable surface (e.g.,

S-2 Spill Prevention, Containment and Control

impermeable liner, asphalt or concrete) to prevent groundwater contamination. The containment system must be designed to enable collection and removal of spilled material through a pump or vacuum trucks, use of sorbent or gelling material, or other measures. Material removed from the spill area must be disposed of or recycled according to local, state, and federal standards.

If the capacity of the containment berming or the collection basin is exceeded, supplemental spill control measures should be available such as a portable containment device, sorbent materials, or gelling agents that eventually solidify the material. Water that collects within containment areas due to rainfall or snowmelt must be appropriately treated before release from the spill area.

Spill Plan Development

Many industries are required by federal law to have a Spill Prevention, Control and Countermeasures Plan (SPCC) that meets specific regulatory criteria when certain types and quantities of materials are used or processed at a site. These plans can be instrumental in developing a spill control plan for stormwater management purposes. Even if an SPCC plan is not legally required at a site, a spill control plan for stormwater management purposes may be necessary. Representative information appropriate for a spill control plan, building on concepts previously introduced in this Fact Sheet, includes:

- Site plan showing where materials are stored and handled, and where associated activities occur.
- Notification procedures to be used in the event of an accident
- Instructions for clean-up procedures.
- A designated person with spill response and clean-up authority.
- Training of key personnel in plan and clean-up procedures.
- Signs posted at critical locations providing a summary of SPCC plan information, phone numbers, contacts, equipment locations, etc.
- Provisions requiring spills to be cleaned up, corrective actions taken, or countermeasures implemented immediately.
- Provisions for absorbents to be made available for use in fuel areas, and for containers to be available for used absorbents.
- Prohibition on washing absorbents into the storm drainage system or into the sanitary sewer system via floor drains.
- Provision for emergency spill containment and clean-up kits in accessible and convenient locations. Kits should contain the appropriate clean-up materials applicable to the materials stored at the site.

Key Spill Notification Contacts in Colorado

- Colorado Department of Public Health and Environment Toll-Free 24-hour Environmental Emergency Spill Reporting Line: 1-877-518-5608
- National Response Center: 1-800-424-8802 (24-hour)
- Local Emergency Planning Committee (OEM): 303-273-162
- Division of Oil & Public Safety-Storage Tanks: 303-318-8547
- Oil and Gas Conservation Commission: 303-894-2100 or 1-888-235-1101 (toll-free spill/complaint line)

Description

Vehicle tracking controls provide stabilized construction site access where vehicles exit the site onto paved public roads. An effective vehicle tracking control helps remove sediment (mud or dirt) from vehicles, reducing tracking onto the paved surface.



Photograph VTC-1. A vehicle tracking control pad constructed with properly sized rock reduces off-site sediment tracking.

Appropriate Uses

Implement a stabilized construction entrance or vehicle tracking control where frequent heavy vehicle traffic exits the construction site onto a paved roadway. An effective vehicle tracking control is particularly important during the following conditions:

- Wet weather periods when mud is easily tracked off site.
- During dry weather periods where dust is a concern.
- When poorly drained, clayey soils are present on site.

Although wheel washes are not required in designs of vehicle tracking controls, they may be needed at particularly muddy sites.

Design and Installation

Construct the vehicle tracking control on a level surface. Where feasible, grade the tracking control towards the construction site to reduce off-site runoff. Place signage, as needed, to direct construction vehicles to the designated exit through the vehicle tracking control. There are several different types of stabilized construction entrances including:

VTC-1. Aggregate Vehicle Tracking Control. This is a coarse-aggregate surfaced pad underlain by a geotextile. This is the most common vehicle tracking control, and when properly maintained can be effective at removing sediment from vehicle tires.

VTC-2. Vehicle Tracking Control with Construction Mat or Turf Reinforcement Mat. This type of control may be appropriate for site access at very small construction sites with low traffic volume over vegetated areas. Although this application does not typically remove sediment from vehicles, it helps protect existing vegetation and provides a stabilized entrance.

Vehicle Tracking Control	
Functions	
Erosion Control	Moderate
Sediment Control	Yes
Site/Material Management	Yes

VTC-3. Stabilized Construction Entrance/Exit with Wheel Wash. This is an aggregate pad, similar to VTC-1, but includes equipment for tire washing. The wheel wash equipment may be as simple as hand-held power washing equipment to more advanced proprietary systems. When a wheel wash is provided, it is important to direct wash water to a sediment trap prior to discharge from the site.

Vehicle tracking controls are sometimes installed in combination with a sediment trap to treat runoff.

Maintenance and Removal

Inspect the area for degradation and replace aggregate or material used for a stabilized entrance/exit as needed. If the area becomes clogged and ponds water, remove and dispose of excess sediment or replace material with a fresh layer of aggregate as necessary.

With aggregate vehicle tracking controls, ensure rock and debris from this area do not enter the public right-of-way.

Remove sediment that is tracked onto the public right of way daily or more frequently as needed. Excess sediment in the roadway indicates that the stabilized construction entrance needs maintenance.

Ensure that drainage ditches at the entrance/exit area remain clear.

A stabilized entrance should be removed only when there is no longer the potential for vehicle tracking to occur. This is typically after the site has been stabilized.

When wheel wash equipment is used, be sure that the wash water is discharged to a sediment trap prior to discharge. Also inspect channels conveying the water from the wash area to the sediment trap and stabilize areas that may be eroding.

When a construction entrance/exit is removed, excess sediment from the aggregate should be removed and disposed of appropriately. The entrance should be promptly stabilized with a permanent surface following removal, typically by paving.



Photograph VTC-2. A vehicle tracking control pad with wheel wash facility. Photo courtesy of Tom Gore.

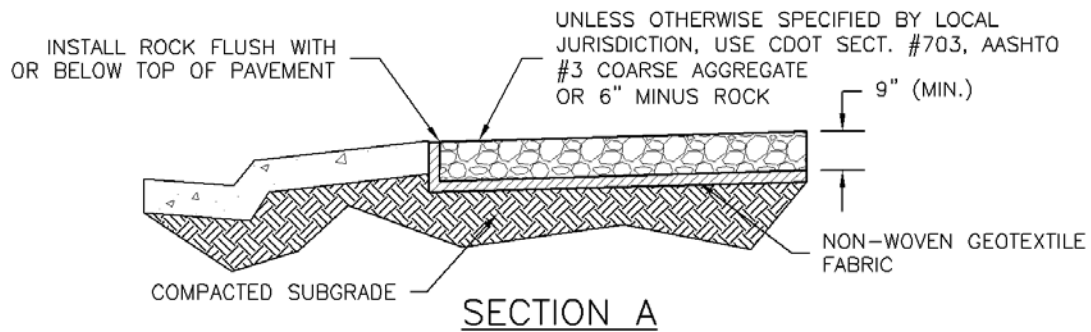
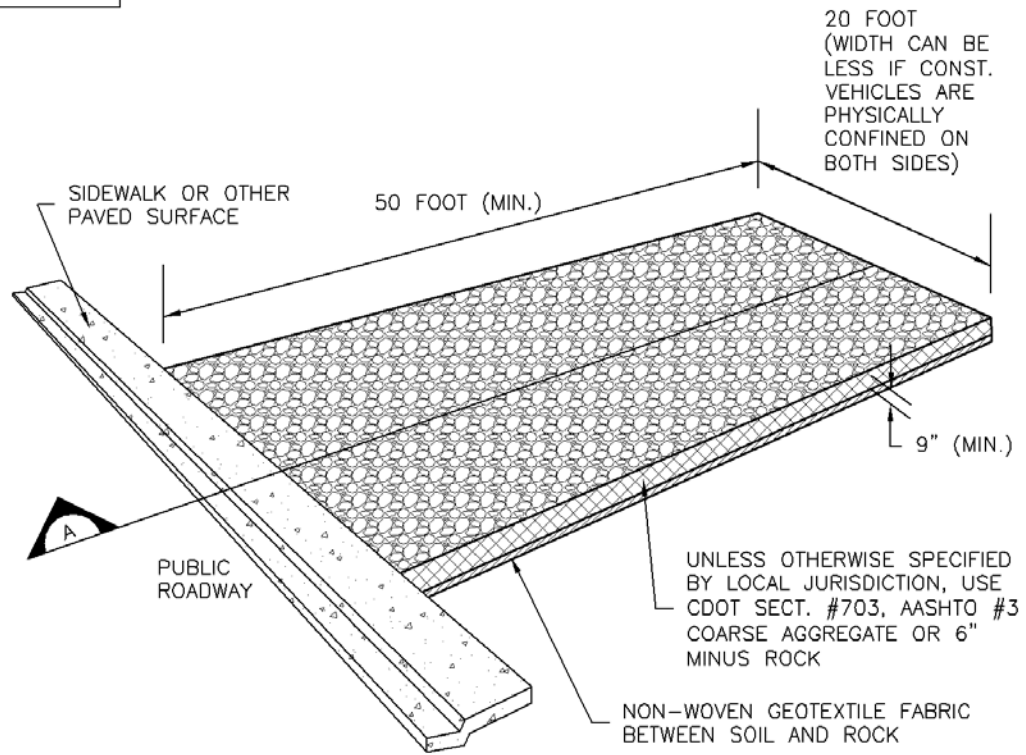
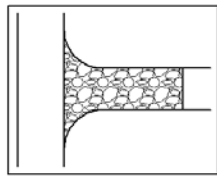

VTC-1. AGGREGATE VEHICLE TRACKING CONTROL

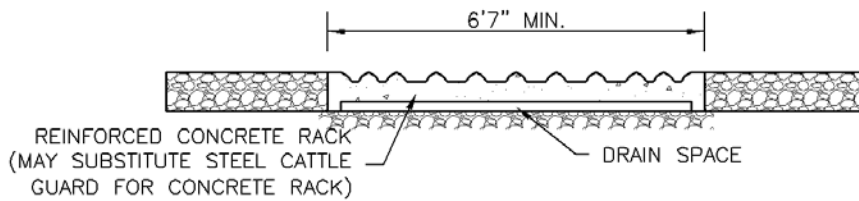
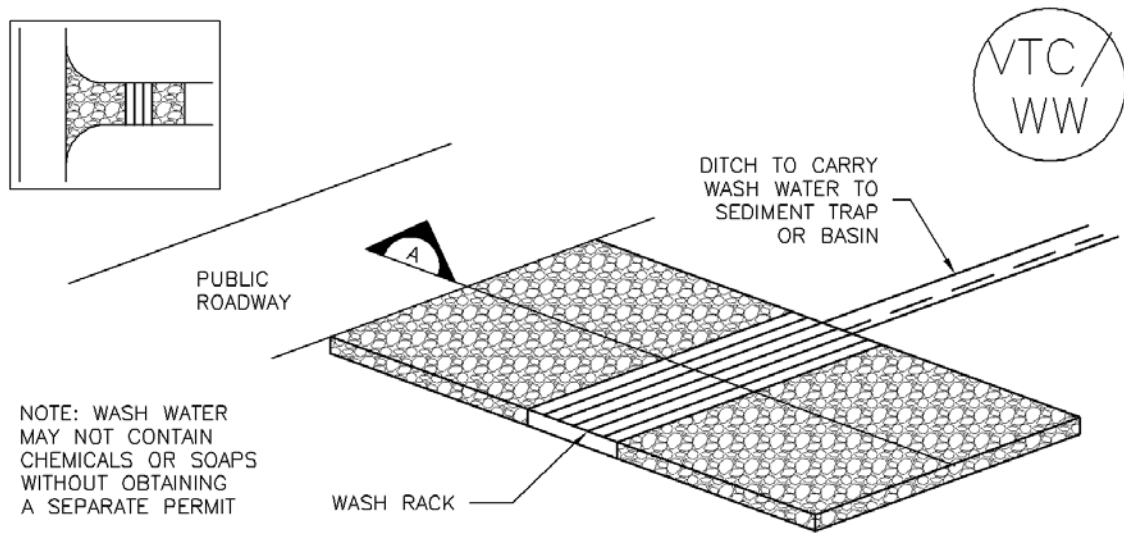

SECTION A

VTC-2. AGGREGATE VEHICLE TRACKING CONTROL WITH WASH RACK

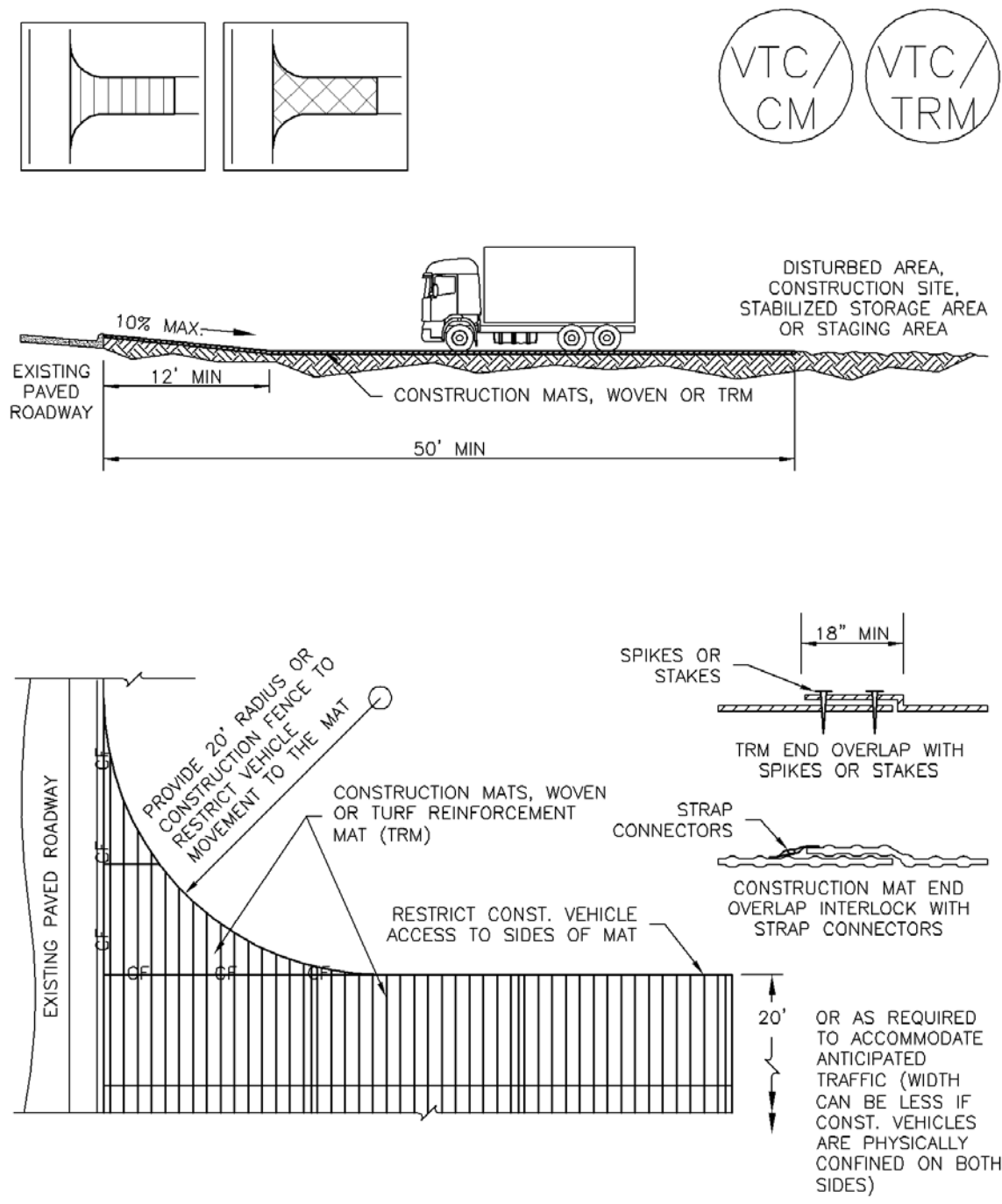

VTC-3. VEHICLE TRACKING CONTROL W/ CONSTRUCTION MAT OR TURF REINFORCEMENT MAT (TRM)

STABILIZED CONSTRUCTION ENTRANCE/EXIT INSTALLATION NOTES

1. SEE PLAN VIEW FOR
 - LOCATION OF CONSTRUCTION ENTRANCE(S)/EXIT(S).
 - TYPE OF CONSTRUCTION ENTRANCE(S)/EXITS(S) (WITH/WITHOUT WHEEL WASH, CONSTRUCTION MAT OR TRM).
2. CONSTRUCTION MAT OR TRM STABILIZED CONSTRUCTION ENTRANCES ARE ONLY TO BE USED ON SHORT DURATION PROJECTS (TYPICALLY RANGING FROM A WEEK TO A MONTH) WHERE THERE WILL BE LIMITED VEHICULAR ACCESS.
3. A STABILIZED CONSTRUCTION ENTRANCE/EXIT SHALL BE LOCATED AT ALL ACCESS POINTS WHERE VEHICLES ACCESS THE CONSTRUCTION SITE FROM PAVED RIGHT-OF-WAYS.
4. STABILIZED CONSTRUCTION ENTRANCE/EXIT SHALL BE INSTALLED PRIOR TO ANY LAND DISTURBING ACTIVITIES.
5. A NON-WOVEN GEOTEXTILE FABRIC SHALL BE PLACED UNDER THE STABILIZED CONSTRUCTION ENTRANCE/EXIT PRIOR TO THE PLACEMENT OF ROCK.
6. UNLESS OTHERWISE SPECIFIED BY LOCAL JURISDICTION, ROCK SHALL CONSIST OF DOT SECT. #703, AASHTO #3 COARSE AGGREGATE OR 6" (MINUS) ROCK.

STABILIZED CONSTRUCTION ENTRANCE/EXIT MAINTENANCE NOTES

1. INSPECT BMPs EACH WORKDAY, AND MAINTAIN THEM IN EFFECTIVE OPERATING CONDITION. MAINTENANCE OF BMPs SHOULD BE PROACTIVE, NOT REACTIVE. INSPECT BMPs AS SOON AS POSSIBLE (AND ALWAYS WITHIN 24 HOURS) FOLLOWING A STORM THAT CAUSES SURFACE EROSION, AND PERFORM NECESSARY MAINTENANCE.
2. FREQUENT OBSERVATIONS AND MAINTENANCE ARE NECESSARY TO MAINTAIN BMPs IN EFFECTIVE OPERATING CONDITION. INSPECTIONS AND CORRECTIVE MEASURES SHOULD BE DOCUMENTED THOROUGHLY.
3. WHERE BMPs HAVE FAILED, REPAIR OR REPLACEMENT SHOULD BE INITIATED UPON DISCOVERY OF THE FAILURE.
4. ROCK SHALL BE REAPPLIED OR REGRADED AS NECESSARY TO THE STABILIZED ENTRANCE/EXIT TO MAINTAIN A CONSISTENT DEPTH.
5. SEDIMENT TRACKED ONTO PAVED ROADS IS TO BE REMOVED THROUGHOUT THE DAY AND AT THE END OF THE DAY BY SHOVELING OR SWEEPING. SEDIMENT MAY NOT BE WASHED DOWN STORM SEWER DRAINS.

NOTE: MANY JURISDICTIONS HAVE BMP DETAILS THAT VARY FROM UDFCD STANDARD DETAILS. CONSULT WITH LOCAL JURISDICTIONS AS TO WHICH DETAIL SHOULD BE USED WHEN DIFFERENCES ARE NOTED.

(DETAILS ADAPTED FROM CITY OF BROOMFIELD, COLORADO, NOT AVAILABLE IN AUTOCAD)

Description

A silt fence is a woven geotextile fabric attached to wooden posts and trenched into the ground. It is designed as a sediment barrier to intercept sheet flow runoff from disturbed areas.

Appropriate Uses

A silt fence can be used where runoff is conveyed from a disturbed area as sheet flow. Silt fence is not designed to receive concentrated flow or to be used as a filter fabric. Typical uses include:

- Down slope of a disturbed area to accept sheet flow.
- Along the perimeter of a receiving water such as a stream, pond or wetland.
- At the perimeter of a construction site.



Photograph SF-1. Silt fence creates a sediment barrier, forcing sheet flow runoff to evaporate or infiltrate.

Design and Installation

Silt fence should be installed along the contour of slopes so that it intercepts sheet flow. The maximum recommended tributary drainage area per 100 lineal feet of silt fence, installed along the contour, is approximately 0.25 acres with a disturbed slope length of up to 150 feet and a tributary slope gradient no steeper than 3:1. Longer and steeper slopes require additional measures. This recommendation only applies to silt fence installed along the contour. Silt fence installed for other uses, such as perimeter control, should be installed in a way that will not produce concentrated flows. For example, a "J-hook" installation may be appropriate to force runoff to pond and evaporate or infiltrate in multiple areas rather than concentrate and cause erosive conditions parallel to the silt fence.

See Detail SF-1 for proper silt fence installation, which involves proper trenching, staking, securing the fabric to the stakes, and backfilling the silt fence. Properly installed silt fence should not be easily pulled out by hand and there should be no gaps between the ground and the fabric.

Silt fence must meet the minimum allowable strength requirements, depth of installation requirement, and other specifications in the design details. Improper installation of silt fence is a common reason for silt fence failure; however, when properly installed and used for the appropriate purposes, it can be highly effective.

Silt Fence	
Functions	
Erosion Control	No
Sediment Control	Yes
Site/Material Management	No

Maintenance and Removal

Inspection of silt fence includes observing the material for tears or holes and checking for slumping fence and undercut areas bypassing flows. Repair of silt fence typically involves replacing the damaged section with a new section. Sediment accumulated behind silt fence should be removed, as needed to maintain BMP effectiveness, typically before it reaches a depth of 6 inches.

Silt fence may be removed when the upstream area has reached final stabilization.



Photograph SF-2. When silt fence is not installed along the contour, a "J-hook" installation may be appropriate to ensure that the BMP does not create concentrated flow parallel to the silt fence. Photo courtesy of Tom Gore.

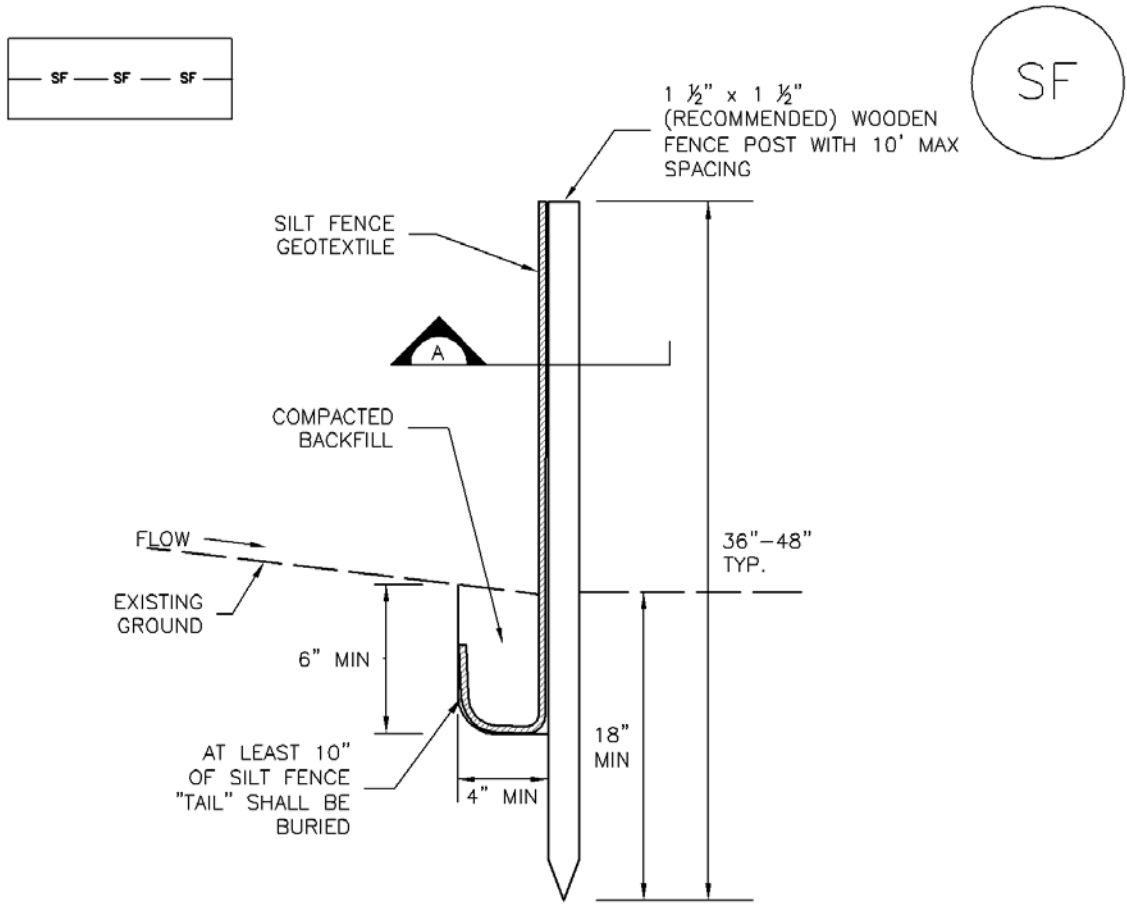

SILT FENCE

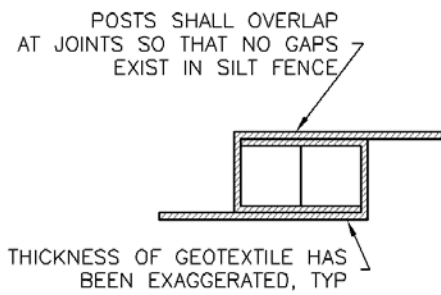
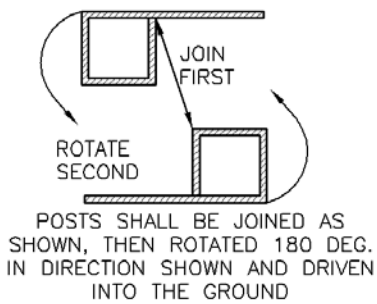

SECTION A

SF-1. SILT FENCE

SILT FENCE INSTALLATION NOTES

1. SILT FENCE MUST BE PLACED AWAY FROM THE TOE OF THE SLOPE TO ALLOW FOR WATER PONDING. SILT FENCE AT THE TOE OF A SLOPE SHOULD BE INSTALLED IN A FLAT LOCATION AT LEAST SEVERAL FEET (2-5 FT) FROM THE TOE OF THE SLOPE TO ALLOW ROOM FOR PONDING AND DEPOSITION.
2. A UNIFORM 6" X 4" ANCHOR TRENCH SHALL BE EXCAVATED USING TRENCHER OR SILT FENCE INSTALLATION DEVICE. NO ROAD GRADERS, BACKHOES, OR SIMILAR EQUIPMENT SHALL BE USED.
3. COMPACT ANCHOR TRENCH BY HAND WITH A "JUMPING JACK" OR BY WHEEL ROLLING. COMPACTION SHALL BE SUCH THAT SILT FENCE RESISTS BEING PULLED OUT OF ANCHOR TRENCH BY HAND.
4. SILT FENCE SHALL BE PULLED TIGHT AS IT IS ANCHORED TO THE STAKES. THERE SHOULD BE NO NOTICEABLE SAG BETWEEN STAKES AFTER IT HAS BEEN ANCHORED TO THE STAKES.
5. SILT FENCE FABRIC SHALL BE ANCHORED TO THE STAKES USING 1" HEAVY DUTY STAPLES OR NAILS WITH 1" HEADS. STAPLES AND NAILS SHOULD BE PLACED 3" ALONG THE FABRIC DOWN THE STAKE.
6. AT THE END OF A RUN OF SILT FENCE ALONG A CONTOUR, THE SILT FENCE SHOULD BE TURNED PERPENDICULAR TO THE CONTOUR TO CREATE A "J-HOOK." THE "J-HOOK" EXTENDING PERPENDICULAR TO THE CONTOUR SHOULD BE OF SUFFICIENT LENGTH TO KEEP RUNOFF FROM FLOWING AROUND THE END OF THE SILT FENCE (TYPICALLY 10' - 20').
7. SILT FENCE SHALL BE INSTALLED PRIOR TO ANY LAND DISTURBING ACTIVITIES.

SILT FENCE MAINTENANCE NOTES

1. INSPECT BMPs EACH WORKDAY, AND MAINTAIN THEM IN EFFECTIVE OPERATING CONDITION. MAINTENANCE OF BMPs SHOULD BE PROACTIVE, NOT REACTIVE. INSPECT BMPs AS SOON AS POSSIBLE (AND ALWAYS WITHIN 24 HOURS) FOLLOWING A STORM THAT CAUSES SURFACE EROSION, AND PERFORM NECESSARY MAINTENANCE.
2. FREQUENT OBSERVATIONS AND MAINTENANCE ARE NECESSARY TO MAINTAIN BMPs IN EFFECTIVE OPERATING CONDITION. INSPECTIONS AND CORRECTIVE MEASURES SHOULD BE DOCUMENTED THOROUGHLY.
3. WHERE BMPs HAVE FAILED, REPAIR OR REPLACEMENT SHOULD BE INITIATED UPON DISCOVERY OF THE FAILURE.
4. SEDIMENT ACCUMULATED UPSTREAM OF THE SILT FENCE SHALL BE REMOVED AS NEEDED TO MAINTAIN THE FUNCTIONALITY OF THE BMP, TYPICALLY WHEN DEPTH OF ACCUMULATED SEDIMENTS IS APPROXIMATELY 6".
5. REPAIR OR REPLACE SILT FENCE WHEN THERE ARE SIGNS OF WEAR, SUCH AS SAGGING, TEARING, OR COLLAPSE.
6. SILT FENCE IS TO REMAIN IN PLACE UNTIL THE UPSTREAM DISTURBED AREA IS STABILIZED AND APPROVED BY THE LOCAL JURISDICTION, OR IS REPLACED BY AN EQUIVALENT PERIMETER SEDIMENT CONTROL BMP.
7. WHEN SILT FENCE IS REMOVED, ALL DISTURBED AREAS SHALL BE COVERED WITH TOPSOIL, SEEDED AND MULCHED OR OTHERWISE STABILIZED AS APPROVED BY LOCAL JURISDICTION.

(DETAIL ADAPTED FROM TOWN OF PARKER, COLORADO AND CITY OF AURORA, NOT AVAILABLE IN AUTOCAD)

NOTE: MANY JURISDICTIONS HAVE BMP DETAILS THAT VARY FROM UDFCD STANDARD DETAILS. CONSULT WITH LOCAL JURISDICTIONS AS TO WHICH DETAIL SHOULD BE USED WHEN DIFFERENCES ARE NOTED.

Description

Stockpile management includes measures to minimize erosion and sediment transport from soil stockpiles.

Appropriate Uses

Stockpile management should be used when soils or other erodible materials are stored at the construction site. Special attention should be given to stockpiles in close proximity to natural or manmade storm systems.



Photograph SP-1. A topsoil stockpile that has been partially revegetated and is protected by silt fence perimeter control.

Design and Installation

Locate stockpiles away from all drainage system components including storm sewer inlets. Where practical, choose stockpile locations that that will remain undisturbed for the longest period of time as the phases of construction progress. Place sediment control BMPs around the perimeter of the stockpile, such as sediment control logs, rock socks, silt fence, straw bales and sand bags. See Detail SP-1 for guidance on proper establishment of perimeter controls around a stockpile. For stockpiles in active use, provide a stabilized designated access point on the upgradient side of the stockpile.

Stabilize the stockpile surface with surface roughening, temporary seeding and mulching, erosion control blankets, or soil binders. Soils stockpiled for an extended period (typically for more than 60 days) should be seeded and mulched with a temporary grass cover once the stockpile is placed (typically within 14 days). Use of mulch only or a soil binder is acceptable if the stockpile will be in place for a more limited time period (typically 30-60 days). Timeframes for stabilization of stockpiles noted in this fact sheet are "typical" guidelines. Check permit requirements for specific federal, state, and/or local requirements that may be more prescriptive.

Stockpiles should not be placed in streets or paved areas unless no other practical alternative exists. See the Stabilized Staging Area Fact Sheet for guidance when staging in roadways is unavoidable due to space or right-of-way constraints. For paved areas, rock socks must be used for perimeter control and all inlets with the potential to receive sediment from the stockpile (even from vehicle tracking) must be protected.

Maintenance and Removal

Inspect perimeter controls and inlet protection in accordance with their respective BMP Fact Sheets. Where seeding, mulch and/or soil binders are used, reseeding or reapplication of soil binder may be necessary.

When temporary removal of a perimeter BMP is necessary to access a stockpile, ensure BMPs are reinstalled in accordance with their respective design detail section.

Stockpile Management	
Functions	
Erosion Control	Yes
Sediment Control	Yes
Site/Material Management	Yes

When the stockpile is no longer needed, properly dispose of excess materials and revegetate or otherwise stabilize the ground surface where the stockpile was located.

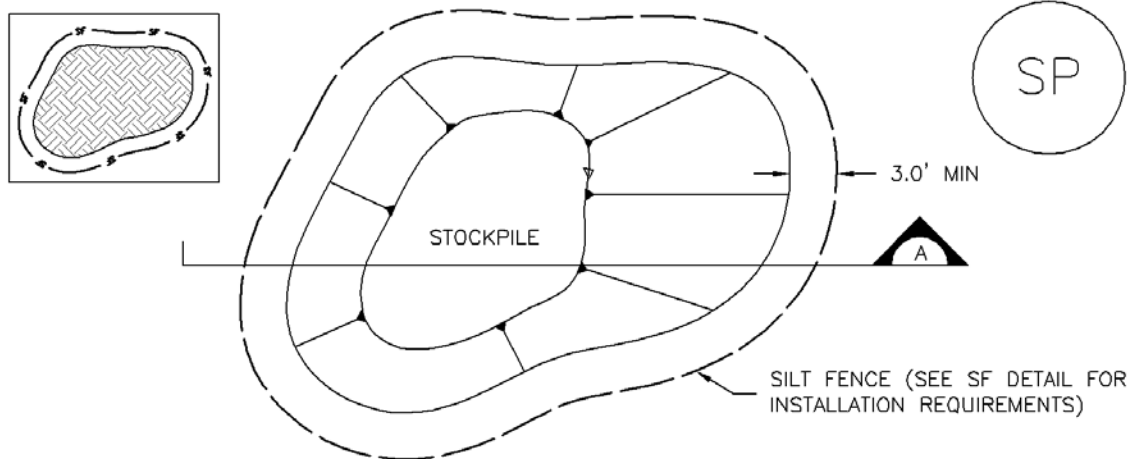

STOCKPILE PROTECTION PLAN

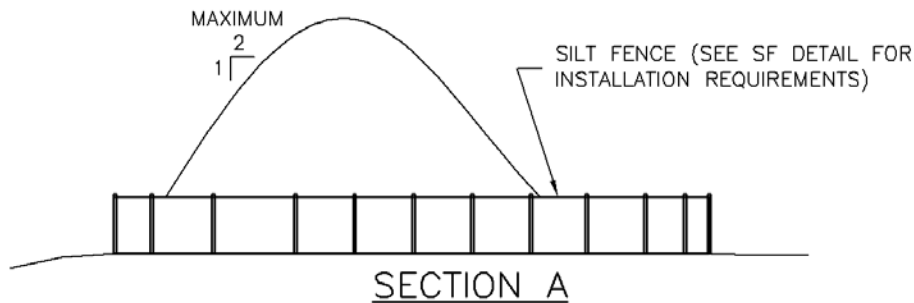

SP-1. STOCKPILE PROTECTION

STOCKPILE PROTECTION INSTALLATION NOTES

1. SEE PLAN VIEW FOR:
 - LOCATION OF STOCKPILES.
 - TYPE OF STOCKPILE PROTECTION.
2. INSTALL PERIMETER CONTROLS IN ACCORDANCE WITH THEIR RESPECTIVE DESIGN DETAILS. SILT FENCE IS SHOWN IN THE STOCKPILE PROTECTION DETAILS; HOWEVER, OTHER TYPES OF PERIMETER CONTROLS INCLUDING SEDIMENT CONTROL LOGS OR ROCK SOCKS MAY BE SUITABLE IN SOME CIRCUMSTANCES. CONSIDERATIONS FOR DETERMINING THE APPROPRIATE TYPE OF PERIMETER CONTROL FOR A STOCKPILE INCLUDE WHETHER THE STOCKPILE IS LOCATED ON A PERVIOUS OR IMPERVIOUS SURFACE, THE RELATIVE HEIGHTS OF THE PERIMETER CONTROL AND STOCKPILE, THE ABILITY OF THE PERIMETER CONTROL TO CONTAIN THE STOCKPILE WITHOUT FAILING IN THE EVENT THAT MATERIAL FROM THE STOCKPILE SHIFTS OR SLUMPS AGAINST THE PERIMETER, AND OTHER FACTORS.
3. STABILIZE THE STOCKPILE SURFACE WITH SURFACE ROUGHENING, TEMPORARY SEEDING AND MULCHING, EROSION CONTROL BLANKETS, OR SOIL BINDERS. SOILS STOCKPILED FOR AN EXTENDED PERIOD (TYPICALLY FOR MORE THAN 60 DAYS) SHOULD BE SEEDING AND MULCHED WITH A TEMPORARY GRASS COVER ONCE THE STOCKPILE IS PLACED (TYPICALLY WITHIN 14 DAYS). USE OF MULCH ONLY OR A SOIL BINDER IS ACCEPTABLE IF THE STOCKPILE WILL BE IN PLACE FOR A MORE LIMITED TIME PERIOD (TYPICALLY 30-60 DAYS).
4. FOR TEMPORARY STOCKPILES ON THE INTERIOR PORTION OF A CONSTRUCTION SITE, WHERE OTHER DOWNGRADIENT CONTROLS, INCLUDING PERIMETER CONTROL, ARE IN PLACE, STOCKPILE PERIMETER CONTROLS MAY NOT BE REQUIRED.

STOCKPILE PROTECTION MAINTENANCE NOTES

1. INSPECT BMPs EACH WORKDAY, AND MAINTAIN THEM IN EFFECTIVE OPERATING CONDITION. MAINTENANCE OF BMPs SHOULD BE PROACTIVE, NOT REACTIVE. INSPECT BMPs AS SOON AS POSSIBLE (AND ALWAYS WITHIN 24 HOURS) FOLLOWING A STORM THAT CAUSES SURFACE EROSION, AND PERFORM NECESSARY MAINTENANCE.

2. FREQUENT OBSERVATIONS AND MAINTENANCE ARE NECESSARY TO MAINTAIN BMPs IN EFFECTIVE OPERATING CONDITION. INSPECTIONS AND CORRECTIVE MEASURES SHOULD BE DOCUMENTED THOROUGHLY.

3. WHERE BMPs HAVE FAILED, REPAIR OR REPLACEMENT SHOULD BE INITIATED UPON DISCOVERY OF THE FAILURE.

STOCKPILE PROTECTION MAINTENANCE NOTES

4. IF PERIMETER PROTECTION MUST BE MOVED TO ACCESS SOIL STOCKPILE, REPLACE PERIMETER CONTROLS BY THE END OF THE WORKDAY.

5. STOCKPILE PERIMETER CONTROLS CAN BE REMOVED ONCE ALL THE MATERIAL FROM THE STOCKPILE HAS BEEN USED.

(DETAILS ADAPTED FROM PARKER, COLORADO, NOT AVAILABLE IN AUTOCAD)

NOTE: MANY JURISDICTIONS HAVE BMP DETAILS THAT VARY FROM UDFCD STANDARD DETAILS. CONSULT WITH LOCAL JURISDICTIONS AS TO WHICH DETAIL SHOULD BE USED WHEN DIFFERENCES ARE NOTED.

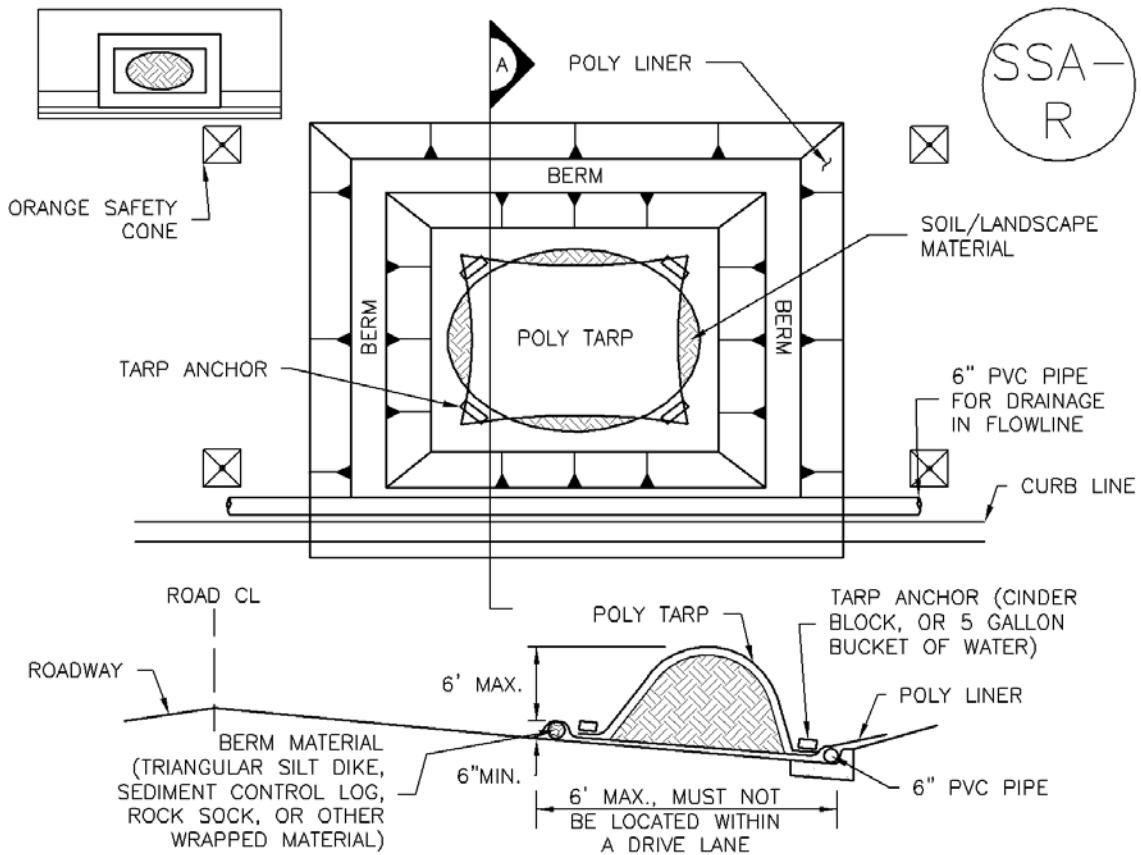

SP-2. MATERIALS STAGING IN ROADWAY

MATERIALS STAGING IN ROADWAYS INSTALLATION NOTES

1. SEE PLAN VIEW FOR
 - LOCATION OF MATERIAL STAGING AREA(S).
 - CONTRACTOR MAY ADJUST LOCATION AND SIZE OF STAGING AREA WITH APPROVAL FROM THE LOCAL JURISDICTION.
2. FEATURE MUST BE INSTALLED PRIOR TO EXCAVATION, EARTHWORK OR DELIVERY OF MATERIALS.
3. MATERIALS MUST BE STATIONED ON THE POLY LINER. ANY INCIDENTAL MATERIALS DEPOSITED ON PAVED SECTION OR ALONG CURB LINE MUST BE CLEANED UP PROMPTLY.
4. POLY LINER AND TARP COVER SHOULD BE OF SIGNIFICANT THICKNESS TO PREVENT DAMAGE OR LOSS OF INTEGRITY.
5. SAND BAGS MAY BE SUBSTITUTED TO ANCHOR THE COVER TARP OR PROVIDE BERMING UNDER THE BASE LINER.
6. FEATURE IS NOT INTENDED FOR USE WITH WET MATERIAL THAT WILL BE DRAINING AND/OR SPREADING OUT ON THE POLY LINER OR FOR DEMOLITION MATERIALS.
7. THIS FEATURE CAN BE USED FOR:
 - UTILITY REPAIRS.
 - WHEN OTHER STAGING LOCATIONS AND OPTIONS ARE LIMITED.
 - OTHER LIMITED APPLICATION AND SHORT DURATION STAGING.

MATERIALS STAGING IN ROADWAY MAINTENANCE NOTES

1. INSPECT BMPs EACH WORKDAY, AND MAINTAIN THEM IN EFFECTIVE OPERATING CONDITION. MAINTENANCE OF BMPs SHOULD BE PROACTIVE, NOT REACTIVE. INSPECT BMPs AS SOON AS POSSIBLE (AND ALWAYS WITHIN 24 HOURS) FOLLOWING A STORM THAT CAUSES SURFACE EROSION, AND PERFORM NECESSARY MAINTENANCE.
2. FREQUENT OBSERVATIONS AND MAINTENANCE ARE NECESSARY TO MAINTAIN BMPs IN EFFECTIVE OPERATING CONDITION. INSPECTIONS AND CORRECTIVE MEASURES SHOULD BE DOCUMENTED THOROUGHLY.
3. WHERE BMPs HAVE FAILED, REPAIR OR REPLACEMENT SHOULD BE INITIATED UPON DISCOVERY OF THE FAILURE.
4. INSPECT PVC PIPE ALONG CURB LINE FOR CLOGGING AND DEBRIS. REMOVE OBSTRUCTIONS PROMPTLY.
5. CLEAN MATERIAL FROM PAVED SURFACES BY SWEEPING OR VACUUMING.

NOTE: MANY JURISDICTIONS HAVE BMP DETAILS THAT VARY FROM UDFCD STANDARD DETAILS. CONSULT WITH LOCAL JURISDICTIONS AS TO WHICH DETAIL SHOULD BE USED WHEN DIFFERENCES ARE NOTED.

(DETAILS ADAPTED FROM AURORA, COLORADO)

GRADING AND EROSION CONTROL PLANS

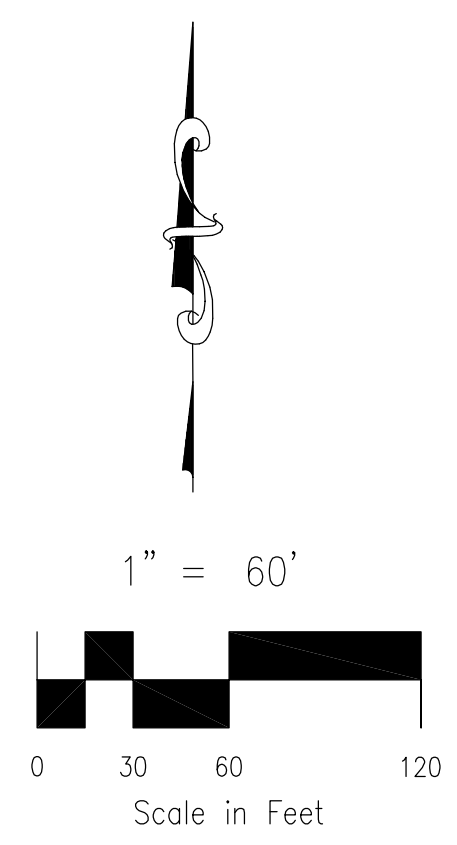
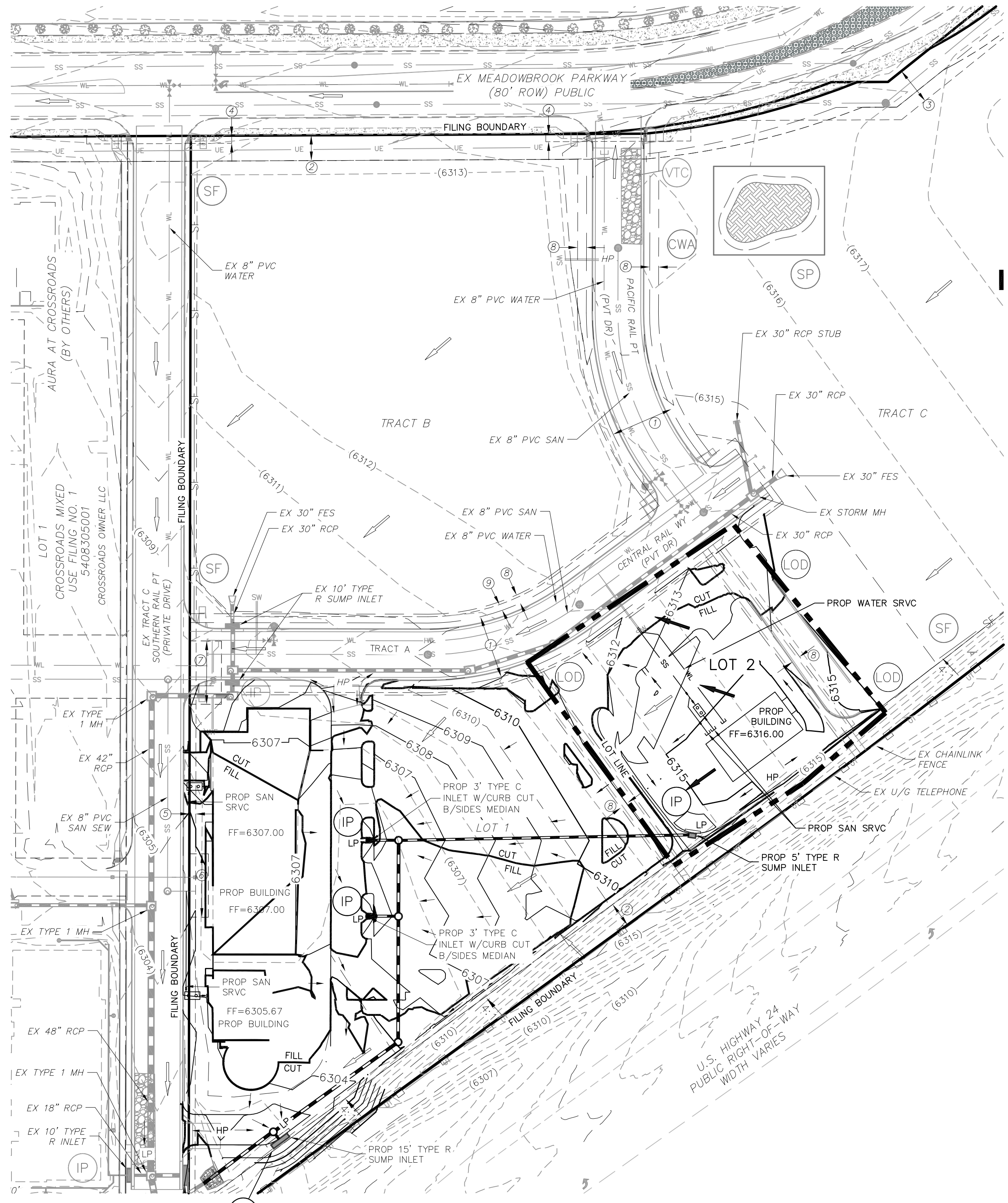

LEGEND

	(6920) —	EXISTING MAJOR CONTOUR
	(6918) —	EXISTING MINOR CONTOUR
	6920 —	PROPOSED MAJOR CONTOUR
	6918 —	PROPOSED MINOR CONTOUR
	—	FILING BOUNDARY (PROPERTY LINE)
	SF	EXIST SILT FENCE (COMPLETED IN INITIAL PHASE TO REMAIN UNTIL FINAL LANDSCAPE IS ESTABLISHED)
	SF	PROP SILT FENCE (COMPLETED IN INITIAL PHASE TO REMAIN UNTIL FINAL LANDSCAPE IS ESTABLISHED)
	LOD	PROP LIMIT OF DISTURBANCE/CONST BNDRY/CONST FENCE
	—	CUT/FILL LINE
	—	EXISTING/FUTURE STORM DRAIN
	—	PROPOSED STORM DRAIN
	L.P./H.P.	LOW POINT/HIGH POINT
	2.1%	FLOW DIRECTION & SLOPE
	—	FLOW DIRECTION ARROW
	—	EXISTING FLOW DIRECTION ARROW
	IP	EXISTING INLET PROTECTION (INITIAL INLET PROTECTION SHALL REMAIN UNTIL FINAL STABILIZATION)
	IP	PROPOSED INLET PROTECTION (INITIAL INLET PROTECTION SHALL REMAIN UNTIL FINAL STABILIZATION)
	VTC	EXISTING VEHICLE TRACKING CONTROL (COMPLETED IN INITIAL PHASE TO REMAIN UNTIL PAVEMENT INSTALL)
	CWA	EXISTING CONCRETE WASHOUT AREA
	CIP	EXISTING CULVERT INLET PROTECTION
	SP	EXISTING STOCKPILE MANAGEMENT INSTALLED IN INITIAL PHASE
	—	EXISTING LOT LINE
	—	EXISTING EASEMENT

NARRATIVE NOTES:

1. LOCATION OF STOCKPILES SHALL BE DETERMINED BY CONTRACTOR. ALL STOCKPILES SHALL REMAIN WITHIN THE CONSTRUCTION BOUNDARIES AS INDICATED ON THE SITE MAP.
2. THE EXACT LOCATION FOR THE STABILIZED STAGING AREA, STORAGE EQUIPMENT AND TEMPORARY DISPOSAL AREAS SHALL BE DETERMINED IN THE FIELD BY THE CONTRACTOR. PLAN SHALL BE UPDATED BY CONTRACTOR UPON DETERMINATION OF EXACT LOCATION.
3. FINAL STABILIZATION SHALL BE COMPLETED AT THE END OF THE CONSTRUCTION ACTIVITIES. ALL AREAS DISTURBED WITHIN THE CONSTRUCTION BOUNDARY/LIMITS OF DISTURBANCE AREA SHALL BE RESEEDED WITH NATIVE SEEDING.
4. EROSION CONTROL BLANKET SHALL BE USED ON SLOPES GREATER THAN 4:1.
5. REFER TO CROSSROADS MULTI USE FILING NO. 2 CONSTRUCTION PLANS BY M&S CIVIL CONSULTANTS FOR ADDITIONAL DETAIL.

ADDITIONAL NOTES:

1. INITIAL EROSION CONTROL MEASURES FOR LOT 1 ALONG WITH OVERLOT GRADING WERE PREVIOUSLY INSTALLED UNDER EPC PROJECT NO. _____ BY M&S CIVIL CONSULTANTS, INC.
2. THE EROSION CONTROL DELINEATED ON THIS PLAN SHALL BE REGULARLY UPDATED BY THE CONTRACTOR.
3. OFFSITE GRADING NEAR HWY 24 TO BE APPROVED BY EPC
4. LOCATIONS OF ALL NON-STRUCTURAL CONTROL MEASURES. NONSTRUCTURAL CONTROLS (LIKE STREET SWEEPING) WITHOUT A SPECIFIC LOCATION MAY BE DESCRIBED USING NOTES.
5. PROPOSED SLOPES SHALL BE 4:1 OR GREATER.
6. THE CONTRACTOR SHALL OBTAIN A COPY OF THE GEOTECHNICAL ENGINEERING REPORT AND KEEP A COPY ONSITE DURING ALL EARTHWORK OPERATIONS.
7. TO REDUCED RUNOFF EROSION, THE CONTRACTOR SHALL IMPLEMENT SURFACING ROUGHING MEASURES OVER LARGER AREAS OF THE SITE. IF WEATHER DICTATES, THE CONTRACTOR SHOULD UTILIZE WATERING NON-STRUCTURAL MEASUREMENTS TO MINIMIZE WIND EROSION. THE SITE SHOULD BE MULCHED AFTER INTERIM GRADING WITHIN 21 DAYS, AND THE SITE SHALL BE SEEDDED IF CONSTRUCTION DOESN'T COMMENCE WITHIN 60 DAYS, PER EPC STANDARDS SPECIFICATIONS.
8. NO ASPHALT/CONCRETE. BATCH PLANTS SHALL BE UTILIZED ON THIS SITE.

KEY NOTES:

- ① PROP 50' UTILITY EASEMENT REC NO. _____
- ② 20' PUBLIC UTILITY & DRAINAGE EASEMENT REC NO. 222714975
- ③ 30' ACCESS & SAN SEWER EASEMENT REC NO. 217713939
- ④ 6' PUBLIC IMPROVEMENT EASEMENT REC NO. 222714975
- ⑤ 5' PUBLIC IMPROVEMENT, UTILITY & DRAINAGE EASEMENT REC NO. 222714975
- ⑥ 15'x50.08' UTILITY EASEMENT REC NO 222714975
- ⑦ 25'x50' UTILITY EASEMENT REC NO. 222714975
- ⑧ 7' DRAINAGE EASEMENT
- ⑨ 5' PUBLIC UTILITY, IMPROVEMENT AND DRAINAGE EASEMENT

VEGETATION:

EXISTING VEGETATION: EPC APPROVED SEED MIX INSTALLED WITH OVERLOT GRADING REFER TO GRADING AND EROSION CONTROL PLANS BY M&S CIVIL CONSULTANTS, INC. EPC PROJECT NOS. SF _____ (SEE ADDITIONAL NOTE 1)

TEMPORARY NON-STRUCTURAL PRACTICES:

TO REDUCED RUNOFF EROSION, THE CONTRACTOR SHALL IMPLEMENT SURFACING ROUGHING MEASURES OVER LARGER AREAS OF THE SITE. IF WEATHER DICTATES, THE CONTRACTOR SHOULD UTILIZE WATERING NON-STRUCTURAL MEASUREMENTS TO MINIMIZE WIND EROSION. THE SITE SHOULD BE MULCHED AFTER INTERIM GRADING WITHIN 21 DAYS, AND THE SITE SHALL BE SEEDDED IF CONSTRUCTION DOESN'T COMMENCE WITHIN 60 DAYS, PER EL PASO COUNTY (EPC) STANDARDS.

FOR LOCATING & MARKING GAS, ELECTRIC, WATER & TELEPHONE LINES

FOR BURIED UTILITY INFORMATION
48 HRS BEFORE YOU DIG
CALL 1-800-922-1987

LOT 2 - CROSSROADS MIXED USE FILING NO. 2

INTERIM GRADING & EROSION CONTROL PLAN

PROJECT NO. 18-005 DATE: 02/10/2023

SCALE: HORIZONTAL: 1"=60' VERTICAL: N/A

DESIGNED BY: VAS CHECKED BY: VAS

DRAWN BY: CLP SHEET 2 OF 7

GEC02

212 N. WASHCATCH AVE., STE 305
COLORADO SPRINGS, CO 80903
PHONE: 719.555.5485

CIVIL CONSULTANTS, INC.

FOR AND ON BEHALF OF M&S CIVIL CONSULTANTS, INC.

VIRGIL A. SANCHEZ, COLORADO, P.E. NO. 37160

NO.	DATE	DESCRIPTION	APPROVED BY	DATE

THE ENGINEER PREPARING THESE PLANS WILL NOT BE RESPONSIBLE, OR LIABLE FOR, UNAUTHORIZED CHANGES TO OR USES OF THESE PLANS. ALL CHANGES TO THE PLANS MUST BE IN WRITING AND MUST BE APPROVED BY THE PREPARER OF THESE PLANS.

CAUTION

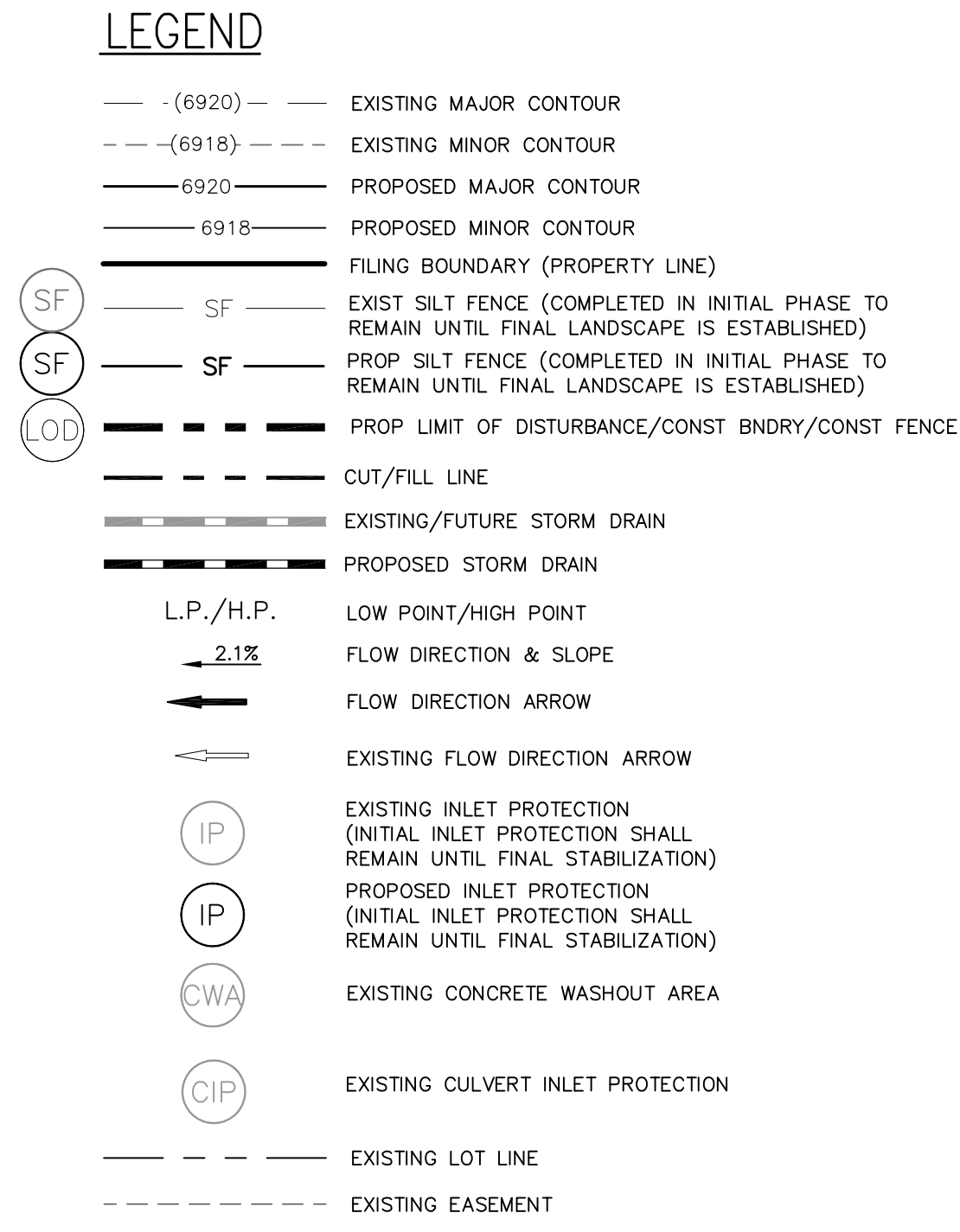
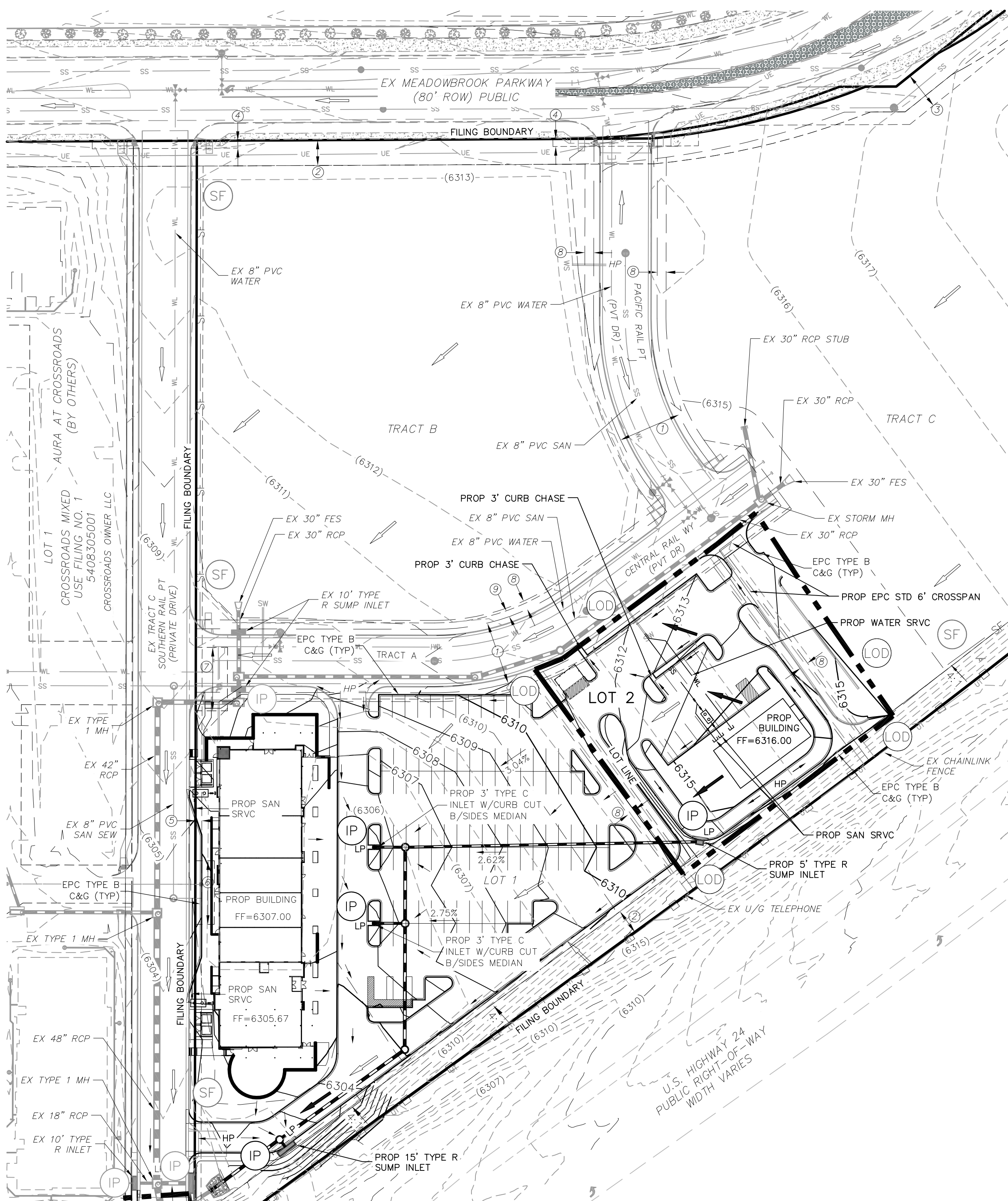

NARRATIVE NOTES:

1. LOCATION OF STOCKPILES SHALL BE DETERMINED BY CONTRACTOR. ALL STOCKPILES SHALL REMAIN WITHIN THE CONSTRUCTION BOUNDARIES AS INDICATED ON THE SITE MAP.
2. THE EXACT LOCATION FOR THE STABILIZED STAGING AREA, STORAGE EQUIPMENT AND TEMPORARY DISPOSAL AREAS SHALL BE DETERMINED IN THE FIELD BY THE CONTRACTOR. PLAN SHALL BE UPDATED BY CONTRACTOR UPON DETERMINATION OF EXACT LOCATION.
3. FINAL STABILIZATION SHALL BE COMPLETED AT THE END OF THE CONSTRUCTION ACTIVITIES. ALL AREAS DISTURBED WITHIN THE CONSTRUCTION BOUNDARY/LIMITS OF DISTURBANCE AREA SHALL BE RESEEDING WITH NATIVE SEEDING.
4. EROSION CONTROL BLANKET SHALL BE USED ON SLOPES GREATER THAN 4:1.
5. REFER TO CROSSROADS MULTI USE FILING NO. 2 CONSTRUCTION PLANS BY M&S CIVIL CONSULTANTS FOR ADDITIONAL DETAIL.

ADDITIONAL NOTES:

1. INITIAL EROSION CONTROL MEASURES FOR LOT 1 ALONG WITH OVERLOT GRADING WERE PREVIOUSLY INSTALLED UNDER EPC PROJECT NO. _____ BY M&S CIVIL CONSULTANTS, INC.
2. THE EROSION CONTROL DELINEATED ON THIS PLAN SHALL BE REGULARLY UPDATED BY THE CONTRACTOR.
3. OFFSITE GRADING NEAR HWY 24 TO BE APPROVED BY EPC
4. LOCATIONS OF ALL NON-STRUCTURAL CONTROL MEASURES. NONSTRUCTURAL CONTROLS (LIKE STREET SWEEPING) WITHOUT A SPECIFIC LOCATION MAY BE DESCRIBED USING NOTES.
5. PROPOSED SLOPES SHALL BE 4:1 OR GREATER.
6. THE CONTRACTOR SHALL OBTAIN A COPY OF THE GEOTECHNICAL ENGINEERING REPORT AND KEEP A COPY ONSITE DURING ALL EARTHWORK OPERATIONS.
7. TO REDUCED RUNOFF EROSION, THE CONTRACTOR SHALL IMPLEMENT SURFACING ROUGHING MEASURES OVER LARGER AREAS OF THE SITE. IF WEATHER DICTATES, THE CONTRACTOR SHOULD UTILIZE WATERING NON-STRUCTURAL MEASUREMENTS TO MINIMIZE WIND EROSION. THE SITE SHOULD BE MULCHED AFTER INTERIM GRADING WITHIN 21 DAYS, AND THE SITE SHALL BE SEEDED IF CONSTRUCTION DOESN'T COMMENCE WITHIN 60 DAYS, PER EPC STANDARDS SPECIFICATIONS.
8. NO ASPHALT/CONCRETE BATCH PLANTS SHALL BE UTILIZED ON THIS SITE.

KEY NOTES:

- ① PROP 50' UTILITY EASEMENT REC NO. _____
- ② 20' PUBLIC UTILITY & DRAINAGE EASEMENT REC NO. 222714975
- ③ 30' ACCESS & SAN SEWER EASEMENT REC NO. 217713939
- ④ 6' PUBLIC IMPROVEMENT EASEMENT REC NO. 222714975
- ⑤ 5' PUBLIC IMPROVEMENT, UTILITY & DRAINAGE EASEMENT REC NO. 222714975
- ⑥ 15'X50.08' UTILITY EASEMENT REC NO. 222714975
- ⑦ 25'X50' UTILITY EASEMENT REC NO. 222714975
- ⑧ 7' DRAINAGE EASEMENT
- ⑨ 5' PUBLIC UTILITY, IMPROVEMENT AND DRAINAGE EASEMENT

VEGETATION:

EXISTING VEGETATION: EPC APPROVED SEED MIX INSTALLED WITH OVERLOT GRADING REFER TO GRADING AND EROSION CONTROL PLANS BY M&S CIVIL CONSULTANTS, INC. EPC PROJECT NOS. SF _____ (SEE ADDITIONAL NOTE 1)

TEMPORARY NON-STRUCTURAL PRACTICES:

TO REDUCED RUNOFF EROSION, THE CONTRACTOR SHALL IMPLEMENT SURFACING ROUGHING MEASURES OVER LARGER AREAS OF THE SITE. IF WEATHER DICTATES, THE CONTRACTOR SHOULD UTILIZE WATERING NON-STRUCTURAL MEASUREMENTS TO MINIMIZE WIND EROSION. THE SITE SHOULD BE MULCHED AFTER INTERIM GRADING WITHIN 21 DAYS, AND THE SITE SHALL BE SEEDED IF CONSTRUCTION DOESN'T COMMENCE WITHIN 60 DAYS, PER EL PASO COUNTY (EPC) STANDARDS.

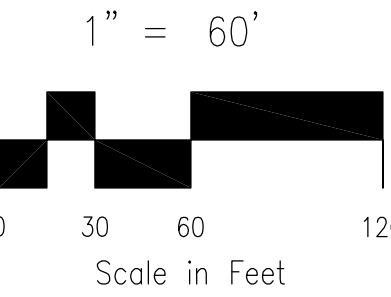

File: C:\Users\epiece\Documents\180054-CRWR-L0T 1\THE EQUITY GROUP\DWG\CONST\DWGS\GRADING\LOT 2\GEC03.dwg Plotted: 2/12/2023 9:35 AM

FOR LOCATING & MARKING GAS, ELECTRIC, WATER & TELEPHONE LINES

FOR BURIED UTILITY INFORMATION 48 HRS BEFORE YOU DIG CALL 1-800-922-1987

LOT 2 – CROSSROADS MIXED USE FILING NO. 2
FINAL GRADING & EROSION CONTROL PLAN

PROJECT NO. 18-005
SCALE: HORIZONTAL: 1"=60' VERTICAL: N/A
DATE: 02/10/2023

DESIGNED BY: VAS
DRAWN BY: CLP
CHECKED BY: VAS

SHEET 3 OF 7
GEC03

210 N. WARATCH AVE, SUITE 305
COLORADO SPRINGS, CO 80903
PHONE: 719.555.5465

CIVIL CONSULTANTS, INC.

FOR AND ON BEHALF OF M&S CIVIL CONSULTANTS, INC.		VIRGIL A. SANCHEZ, COLORADO, P.E. NO. 37160	
REVISED:	NO.	DATE:	DESCRIPTION:

THE ENGINEER PREPARING THESE PLANS WILL NOT BE RESPONSIBLE, OR LIABLE FOR, UNAUTHORIZED CHANGES TO OR USES OF THESE PLANS. ALL CHANGES TO THE PLANS MUST BE IN WRITING AND MUST BE APPROVED BY THE PREPARER OF THESE PLANS.

CAUTION

EL PASO COUNTY FILE NO. SF XX-XXX