



**Planning and Community
 Development Department**
2880 International Circle
Colorado Springs, Colorado 80910
 Phone: 719.520.6300
 Fax: 719.520.6695
 Website www.elpasoco.com

DEVIATION REQUEST AND DECISION FORM

Updated: 6/26/2019

PROJECT INFORMATION

Project Name :	EA File No. 21-191 Owl Place
Schedule No.(s) :	5301001015
Legal Description :	Lot 15 Falcon Ranchettes, El Paso County

APPLICANT INFORMATION

Company :	Drexel, Barrell & Co.		
Name :	Kate Varnum		
	<input type="checkbox"/>	<input checked="" type="checkbox"/>	<input type="checkbox"/>
	Owner	Consultant	Contractor
Mailing Address :	3 South 7th Street, Colorado Springs, CO 80905		
Phone Number :	(719) 260-0887		
FAX Number :			
Email Address :	kvarnum@drexelbarrell.com		

ENGINEER INFORMATION

Company :	Drexel, Barrell & Co.	
Name :	Kate Varnum	Colorado P.E. Number : 53459
Mailing Address :	3 South 7th Street Colorado Springs, CO 80905	
Phone Number :	(719) 260-0887	
FAX Number :		
Email Address :	kvarnum@drexelbarrell.com	

OWNER, APPLICANT, AND ENGINEER DECLARATION

To the best of my knowledge, the information on this application and all additional or supplemental documentation is true, factual and complete. I am fully aware that any misrepresentation of any information on this application may be grounds for denial. I have familiarized myself with the rules, regulations and procedures with respect to preparing and filing this application. I also understand that an incorrect submittal will be cause to have the project removed from the agenda of the Planning Commission, Board of County Commissioners and/or Board of Adjustment or delay review until corrections are made, and that any approval of this application is based on the representations made in the application and may be revoked on any breach of representation or condition(s) of approval.

Signature of owner (or authorized representative)

Date

Engineer's Seal, Signature
And Date of Signature

┌

L J

DEVIATION REQUEST (Attach diagrams, figures, and other documentation to clarify request)

A deviation from the standards of or in **Section 4.1 Providing WQCV** of the Drainage Criteria Manual Volume 2 (DCM) is requested, in conformance with **Section 1.7.2.B Other Specialized BMPs** of the Engineering Criteria Manual.

Identify the specific ECM/DCM standard which a deviation is requested:

The El Paso County Drainage Criteria Manual Vol. 2 code - Section 4.1. states that water quality detention is not to be incorporated into underground facilities. The code specifically states "At this time, water quality detention is not to be incorporated into underground detention facilities, such as installations of buried large-diameter pipe sections, stone trenches, underground "infiltrating" devices, etc."

This variance request is in conformance with the El Paso County Engineering Criteria Manual Section 1.7.2.B Other Specialized BMPs, which states that Development and evaluation of permanent BMPs are continuing processes. Better designs of the BMPs, will be developed and tested. To allow for this progress, additional BMPs will be considered on a case-by-case basis by County Stormwater Staff. Design and sizing details and results of independent testing of the BMP in conditions similar to those at the site will be submitted demonstrating that the BMP will meet or exceed the performance of approved BMPs for the site.

State the reason for the requested deviation:

This deviation request is to propose an alternative permanent BMP than the six standard types of BMPs outlined in the ECM & DCM for providing treatment of the WQCV, due to physical layout and geometry of the site (space limitations), and the presence of the sub-regional detention facility SR4 immediately downstream.

Explain the proposed alternative and compare to the ECM/DCM standards (May provide applicable regional or national standards used as basis):

Of the six types of WQCV facilities established by the ECM & DCM, the only applicable options for this commercial development are:

- Extended detention basin
- Sand filter basin
- Porous landscape detention (rain garden)

Given the project constraints listed in Limits of Consideration section below, and the proximity of the regional detention facility SR4, underground facilities are presented here as an alternative. As the project is still in the preliminary design stage, three underground (proprietary Oldcastle Infrastructure) options are listed below to provide the required water quality treatment for the site:

Option 1. Each of the four lots will have individual units (DVS-96C) that will discharge into the project storm line.
Option 2. Two (DVS-144S) units will provide treatment for two lots before discharging into the project storm line.
Option 3. One (NSBB-1020) unit that will provide treatment for the entire development before discharge.

Each of these units have been preliminarily sized following El Paso County design criteria utilizing specific site parameters such as drainage area, percent imperviousness and target 50% of 75-micron NJCAT TSS removal for the 2-year storm event. This target TSS removal is in conformance with the ECM App I.7.2 Pollutant Removal Standard, which states that the control measure shall be designed to treat stormwater runoff to reduce the event mean concentration of TSS to a median value of 30 mg/L or less for the 80th percentile storm event.

State the reason for the requested deviation:

These proposed units are proposed as Standalone facilities (Ref. MHFD Fact Sheet T-11, UG-9). The WQ requirement will be met by each unit individually in accordance with criteria for TSS removal and with a WQCV release rate of no less than 12 hours. Despite functioning as standalone units, they could also be considered as Pretreatment, given the proximity of the sub-regional detention facility downstream.

By utilizing these underground units, the County Four-Step Process (ECM App I.7.2) is being met to reduce the effective imperviousness of the project site, in the following ways:

Step 1 – Employ Runoff Reduction Practices. Individual pad design will ensure that impervious areas are reduced to every extent practicable, and route runoff from impervious surfaces over landscaped areas and grass buffers to slow down runoff and promote infiltration before being captured by the proposed underground WQ units.

Step 2 – Stabilize Drainageways No natural drainageways exist in proximity to the project site. However the discharge of flows into the sub-regional detention facility to the SW will be designed to minimize impact and scour.

Step 3 – Provide Water Quality Capture Volume (WQCV). Review of the six currently approved WQ devices has resulted in this request for deviation from criteria, in order to provide for a more applicable underground facility. The proposed units will provide for water quality mitigation in conformance with criteria.

Step 4 – Consider Need for Industrial and Commercial BMPs. Onsite standard commercial BMPs will be noted and incorporated into the design of the individual pad sites.

LIMITS OF CONSIDERATION

(At least one of the conditions listed below must be met for this deviation request to be considered.)

- The ECM/DCM standard is inapplicable to the particular situation.
- Topography, right-of-way, or other geographical conditions or impediments impose an undue hardship and an equivalent alternative that can accomplish the same design objective is available and does not compromise public safety or accessibility.
- A change to a standard is required to address a specific design or construction problem, and if not modified, the standard will impose an undue hardship on the applicant with little or no material benefit to the public.

Provide justification:

Development of this site requires the installation of a collector roadway from Owl Place on the north side, tying into the recently constructed Falcon Market Place roundabout on the south edge. The development of this property into approximately 1-acre commercial pads requires that each lot fronts the proposed roadway. The existing grade of the site falls from northeast to southwest, and will be generally maintained in this direction for the developed condition.

The development of this property as a commercial center would indicate that the only applicable WQ facilities would be an extended detention basin, sand filter or a porous landscape detention basin. As established at the pre-application meeting, due to the location of the sub-regional Pond SR4 immediately to the southwest of this property, onsite detention would not be required.

Installation of a WQ facility however, at the furthest point downstream would require it to be located parallel to the Eastonville leg of the Falcon Market Place roundabout, or at the southwest corner of the Owl Place property. Neither location is ideal for the following reasons:

Southwest corner of Owl Place property

- Northerly leg of the roundabout restricts space within the property at the SW corner
- Sub-regional pond SR4 is directly downstream of this project
- Storm lines would need to cross the proposed 10x6 culvert (Floodplain relocation – approved CLOMR)

Southern boundary of Owl Place property

- Emergency spillway would discharge directly into public right-of-way (south, east or west).
- Placement of a pond would require consideration of existing utility easements and ROW dedication along Meridian Road, resulting in far reduced developable area for the southern lot.

CRITERIA FOR APPROVAL

Per ECM section 5.8.7 the request for a deviation may be considered if the request is **not based exclusively on financial considerations**. The deviation must not be detrimental to public safety or surrounding property. The applicant must include supporting information demonstrating compliance with **all of the following criteria**:

The deviation will achieve the intended result with a comparable or superior design and quality of improvement.

The DVS units described above (Options 1 and 2) function by splitting flow evenly between two vortex tubes by a V-shaped weir. The shape of the tubes promotes a circular motion of the incoming stormwater at increased velocities to enhance particle settling through centrifugal force, thereby reducing the event mean concentration of TSS to a median value of 30 mg/L or less. Settled pollutants are collected in an isolated storage area at the bottom of the structure, while floating trash and debris is retained behind baffles that contain the vortex chambers. During peak runoff events, flow in excess of the design treatment flow overtops the bypass weir and exits the system. The NSBB system (Option 3 above), works in a similar fashion but on a larger scale given the increased watershed and runoff rates.

The functionality of these units provides for the required runoff treatment, while maximizing the developable area of the project site and allowing for the incorporation of more efficient landscaped areas and grass buffers.

The deviation will achieve the intended result with a comparable or superior design and quality of improvement.

Acceptance of this method of treatment for this project site will also minimize the possible impact to adjacent properties (e.g. emergency spillway flow path).

Further operational, design and maintenance information for the DVS and NSBB units from the manufacturer is included with this deviation request.

The deviation will not adversely affect safety or operations.

The underground facilities would not compromise public safety or accessibility and would increase useable space of the development. Underground water quality would help with the circulation of the site allowing extra room for vehicles and pedestrians to maneuver safely throughout the site.

The deviation will not adversely affect maintenance and its associated cost.

These water quality facilities will be privately maintained and the owner will follow maintenance intervals based on ECM Standards as well as maintenance requirements provided by the manufacturer. The water quality detention units will be inspected 4 times a year, or after any major storm event. The unit will be pumped and pressure washed at a minimum of once per year. The structure will be inspected for blockage, sediment building, and all materials will be disposed of per local and federal regulations. A maintenance agreement with El Paso County will be required, and all associated costs with maintenance will be handled by the owner of the property.

All maintenance may be conducted without entering the DVS/NSBB structures. Floating trash, debris and oils from the water surface can be removed using an extension on the end of the boom hose of a vacuum truck. The vacuum truck will then be used to completely dewater the structure through the vortex tubes to evacuate all accumulated sediment from the sump, some jetting may be required. Confined space training is not required for regular maintenance.

The deviation will not adversely affect aesthetic appearance.

The self-contained underground water quality unit(s) will not be visible from the surface and will not adversely affect the aesthetic appearance of the site.

The deviation meets the design intent and purpose of the ECM standards.

The intent of this section of the ECM/DCM is to provide for water quality treatment of runoff prior to it entering the downstream system. The use of the underground standalone Oldcastle DVS/NSBB units will provide for this requirement. Third party testing indicates that they will provide the equivalent functional requirement of those facilities presented in the ECM/DCM without impacting downstream facilities.

The deviation meets the control measure requirements of Part I.E.3 and Part I.E.4 of the County's MS4 permit, as applicable.

The deviation is in conformance with Part I.E.3 and Part I.E.4 of the County's MS4 permit. Required control measures will be followed for the deviation until final stabilization. Required codes, resolutions, ordinances, and program documents will be used to meet permit requirements. Control for all pollutants will be designed to follow site plan requirements and maintained for each phase of construction. Site inspection requirements, winter requirements and long-term maintenance will be followed for this deviation.

REVIEW AND RECOMMENDATION:

Approved by the ECM Administrator

This request has been determined to have met the criteria for approval. A deviation from Section _____ of the ECM is hereby granted based on the justification provided.

Γ

⌋

L

⌋

Denied by the ECM Administrator

This request has been determined not to have met criteria for approval. A deviation from Section _____ of the ECM is hereby denied.

Γ

⌋

L

⌋

ECM ADMINISTRATOR COMMENTS/CONDITIONS:

1.1. PURPOSE

The purpose of this resource is to provide a form for documenting the findings and decision by the ECM Administrator concerning a deviation request. The form is used to document the review and decision concerning a requested deviation. The request and decision concerning each deviation from a specific section of the ECM shall be recorded on a separate form.

1.2. BACKGROUND

A deviation is a critical aspect of the review process and needs to be documented to ensure that the deviations granted are applied to a specific development application in conformance with the criteria for approval and that the action is documented as such requests can point to potential needed revisions to the ECM.

1.3. APPLICABLE STATUTES AND REGULATIONS

Section 5.8 of the ECM establishes a mechanism whereby an engineering design standard can be modified when if strictly adhered to, would cause unnecessary hardship or unsafe design because of topographical or other conditions particular to the site, and that a departure may be made without destroying the intent of such provision.

1.4. APPLICABILITY

All provisions of the ECM are subject to deviation by the ECM Administrator provided that one of the following conditions is met:

- The ECM standard is inapplicable to a particular situation.
- Topography, right-of-way, or other geographical conditions or impediments impose an undue hardship on the applicant, and an equivalent alternative that can accomplish the same design objective is available and does not compromise public safety or accessibility.
- A change to a standard is required to address a specific design or construction problem, and if not modified, the standard will impose an undue hardship on the applicant with little or no material benefit to the public.

1.5. TECHNICAL GUIDANCE

The review shall ensure all criteria for approval are adequately considered and that justification for the deviation is properly documented.

1.6. LIMITS OF APPROVAL

Whether a request for deviation is approved as proposed or with conditions, the approval is for project-specific use and shall not constitute a precedent or general deviation from these Standards.

1.7. REVIEW FEES

A Deviation Review Fee shall be paid in full at the time of submission of a request for deviation. The fee for Deviation Review shall be as determined by resolution of the BoCC.

DUAL-VORTEX SEPARATOR (DVS)

Inspection & Maintenance Guide

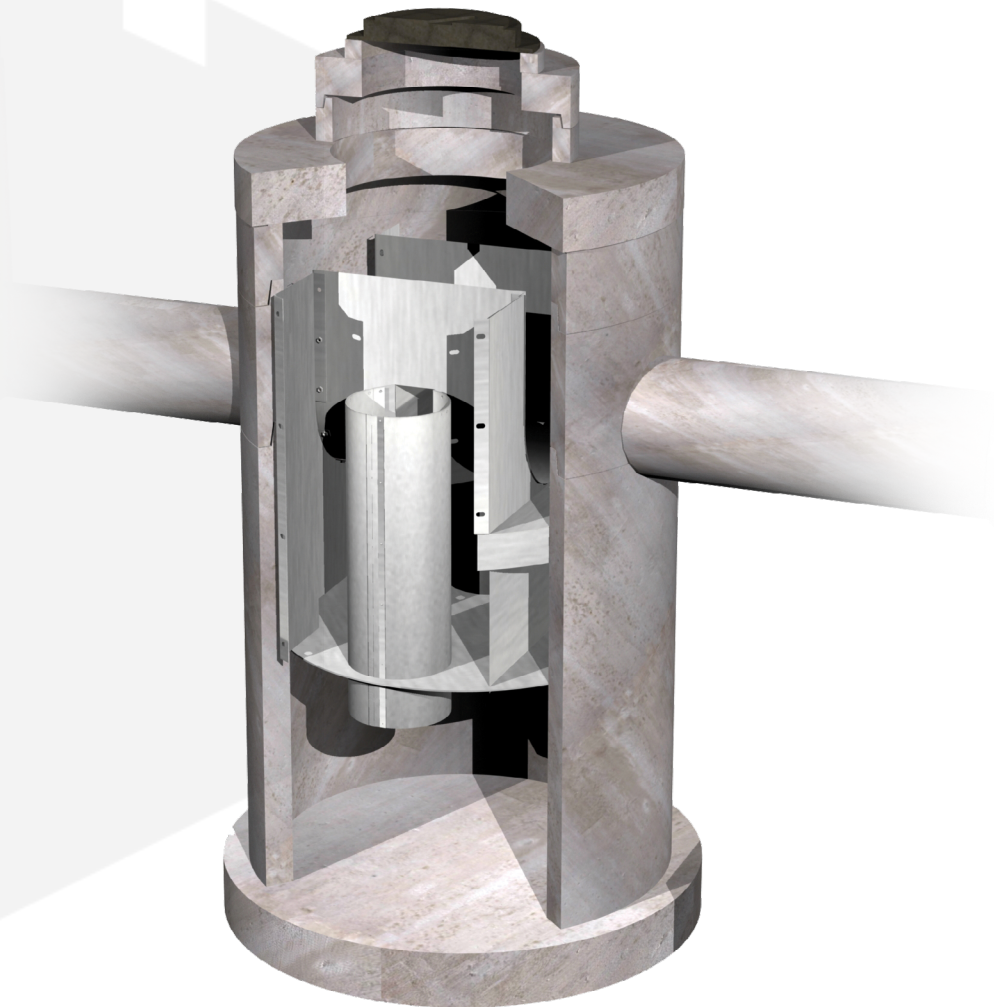

DUAL-VORTEX SEPARATOR (DVS)

DESCRIPTION

The Dual-Vortex Separator (DVS) is a hydrodynamic stormwater treatment device used to remove pollutants from urban runoff. Impervious surfaces and other urban and suburban landscapes generate a variety of contaminants that can enter stormwater and pollute downstream receiving waters. The DVS is designed to capture and retain sediment as well as floating trash, debris and oils. The concentration of metals and other constituents associated with sediment or floating pollutants may also be reduced.

FUNCTION

Stormwater runoff enters the DVS unit through an inlet pipe. Influent flow is split evenly between two vortex tubes by a V-shaped weir. The shape and diameter of the vortex tubes promotes circular motion of the incoming stormwater at increased velocities to enhance particle settling through centrifugal force. The system is also designed with an extended flow path to maximize hydraulic residence time which allows increased time to settle out solids. Settled pollutants are collected in an isolated storage area at the bottom of the structure, while floating trash, debris and petroleum hydrocarbons are retained behind baffles that contain the vortex chambers. During peak runoff events, flow in excess of design treatment flow overtops the bypass weir and exits the system without entering the treatment chambers to interrupt the treatment process or re-entrain captured pollutants. Treatment and bypass flows exit the system through an outlet pipe that is plumbed at the same elevation as the inlet pipe.

CONFIGURATION

The internal components of the DVS system are fabricated from stainless steel and mounted in a manhole or vault structure. The system is typically delivered as a complete unit for installation by the contractor. Installation includes excavation, preparation of the base rock, setting the unit, plumbing the inlet and outlet piping, backfill and placement of the finished surface at grade. Access to the installed system is allowed through ductile iron casting or hatch covers. The number of access points provided is dependent on the size and configuration of the system.

MAINTENANCE OVERVIEW

State and local regulations require all stormwater management systems to be inspected on a regular basis and maintained as necessary to ensure performance and protect downstream receiving waters. Without maintenance, excessive pollutant buildup can limit system performance by reducing the operating capacity and increase the potential for scouring of pollutants during periods of high flow.

INSPECTION EQUIPMENT

The following equipment is helpful when conducting DVS inspections:

- | Recording device (pen and paper form, voice recorder, iPad, etc.)
- | Suitable clothing (appropriate footwear, gloves, hardhat, safety glasses, etc.)
- | Traffic control equipment (cones, barricades, signage, flagging, etc.)
- | Manhole hook or pry bar
- | Flashlight
- | Tape measure
- | Measuring stick or sludge sampler
- | Long-handled net (optional)
- | Replacement Sorbent Pads

INSPECTION PROCEDURES

Inspection is essential to consistent system performance and is easily completed. Inspection is typically conducted a minimum of twice per year but since pollutant transport and deposition varies from site to site, a site-specific maintenance frequency should be established during the first two or three years of operation. DVS inspections are visual and are conducted without entering the unit. To complete an inspection, safety measures including traffic control should be deployed before the access covers are removed. Once the covers have been removed, the following items should be checked and recorded (see form provided on page 5) to determine whether maintenance is required:

- | Inspect the internal components and note whether there are any broken or missing parts. In the unlikely event that internal parts are broken or missing, contact Oldcastle Infrastructure at (800) 579-8819 to determine appropriate corrective action.
- | Note whether the inlet or outlet pipe is blocked or obstructed.
- | Observe, quantify and record the accumulation of floating trash and debris in the baffled chambers around the vortex tubes. The significance of accumulated floating trash and debris is a matter of judgement. A long-handled net may be used to retrieve the bulk of trash and debris at the time of inspection if full maintenance due to accumulation of oils or sediment is not yet warranted.
- | Observe, quantify and record the accumulation of oils in the baffled chambers around the vortex tubes. If sorbent pads have been used to absorb free oil and grease, observe and record their condition. Unless the sorbent pads are tethered to the internal baffles, spent pads may be netted and replaced at the time of inspection. The significance of accumulated floating oils is a matter of judgement. However, if there is evidence of an oil or fuel spill, immediate maintenance is warranted.
- | Finally, observe, quantify and record the accumulation of sediment in the sediment storage sump. A calibrated dipstick, tape measure or sludge sampler may be used to determine the amount of accumulated sediment. The depth of sediment may be determined by calculating the difference between the measurement from the rim of the DVS to the top of the accumulated sediment and the measurement from the rim of the DVS to the bottom of the DVS structure. Finding the top of the accumulated sediment takes some practice and a light touch, but increasing resistance as the measuring device is lowered toward the bottom of the unit indicates the top of the accumulated sediment.

MAINTENANCE INDICATORS

Maintenance should be scheduled if any of the following conditions are identified during inspection:

- | Internal components are broken or missing.
- | Inlet or outlet piping is obstructed.
- | The accumulation of floating trash and debris that cannot be retrieved with a net and/or oil in the baffled chambers around the vortex tubes is significant.
- | Tethered sorbent pads, if used, are dirty or saturated.
- | The sediment level in the sediment storage sump is greater than 12 inches. The capacity of the sediment sump is 18 inches of sediment depth for all DVS models. Sediment depths greater than 18 inches will begin to affect the performance of the system.

MAINTENANCE EQUIPMENT

The following equipment is helpful when conducting DVS maintenance:

- | Suitable clothing (appropriate footwear, gloves, hardhat, safety glasses, etc.)
- | Traffic control equipment (cones, barricades, signage, flagging, etc.)
- | Manhole hook or pry bar
- | Confined space entry equipment, if needed
- | Flashlight
- | Tape measure
- | Sorbent pads
- | Vacuum truck

MAINTENANCE PROCEDURES

Maintenance should be conducted during dry weather when no flow is entering the system. All maintenance, except possibly the attachment of sorbent pads (if required), may be conducted without entering the DVS structure. Once safety measures such as traffic control are deployed, the access covers may be removed and the following activities may be conducted to complete maintenance:

- | Remove floating trash, debris and oils from the water surface using an extension on the end of the boom hose of the vacuum truck. Continue using the vacuum truck to completely dewater the structure through the vortex tubes and evacuate all accumulated sediment from the sediment sump. Some jetting may be required to fully evacuate sediment from the sump. This is easily achieved by inserting a jet hose through the vortex tube opposite the tube used for vacuum hose access.
- | If sorbent pads are required and are tethered to the structure, only personnel that are OSHA Confined Space Entry trained and certified may enter the structure to remove and replace the spent pads.
- | The structure does not need to be refilled with water after maintenance is complete. The system will fill with water when the next storm event occurs.
- | All material removed from the DVS during maintenance must be disposed of in accordance with local regulations. In most cases, the material may be handled in the same manner as disposal of material removed from sumped catch basins or manholes.

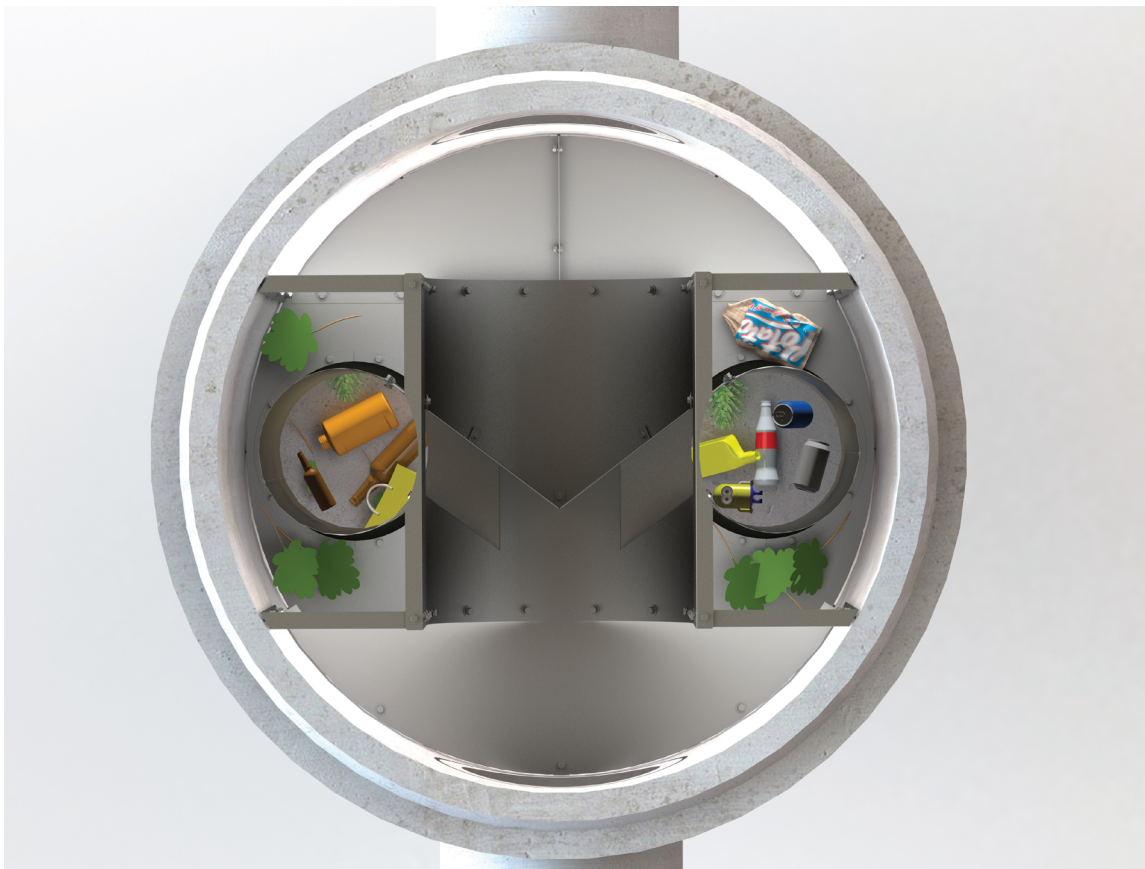
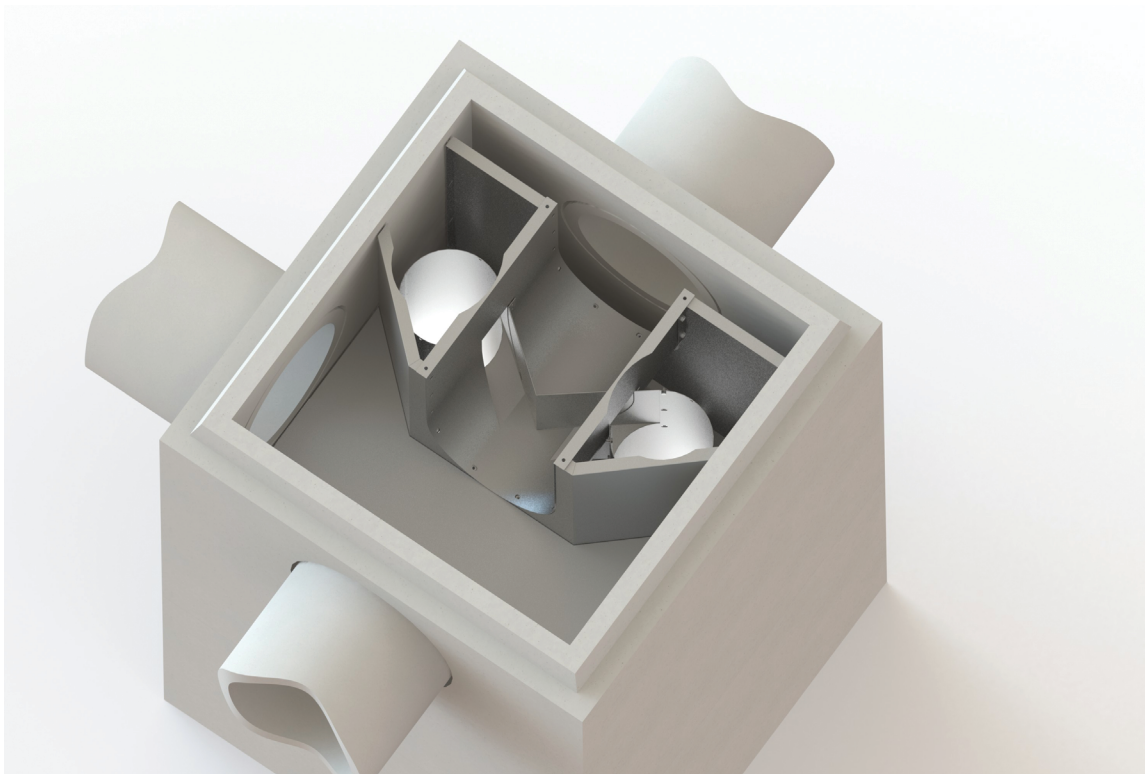

DUAL-VORTEX SEPARATOR INSPECTION AND MAINTENANCE LOG

DVS Model _____ Inspection Date _____

Location _____

Condition of Internal Components

Notes: _____

Good Damaged Missing

Inlet or Outlet Blockage or Obstruction

Notes: _____

Yes No

Floating Trash and Debris

Notes: _____

Significant Not Significant

Floating Oils

Notes: _____

Significant Not Significant Spill

Sediment Depth

Notes: _____

Inches of Sediment _____

Maintenance Requirements

Yes - Schedule Maintenance No - Schedule Re-Inspection



Oldcastle Infrastructure[™]
A CRH COMPANY



DUAL-VORTEX SEPARATOR

Submittal Package

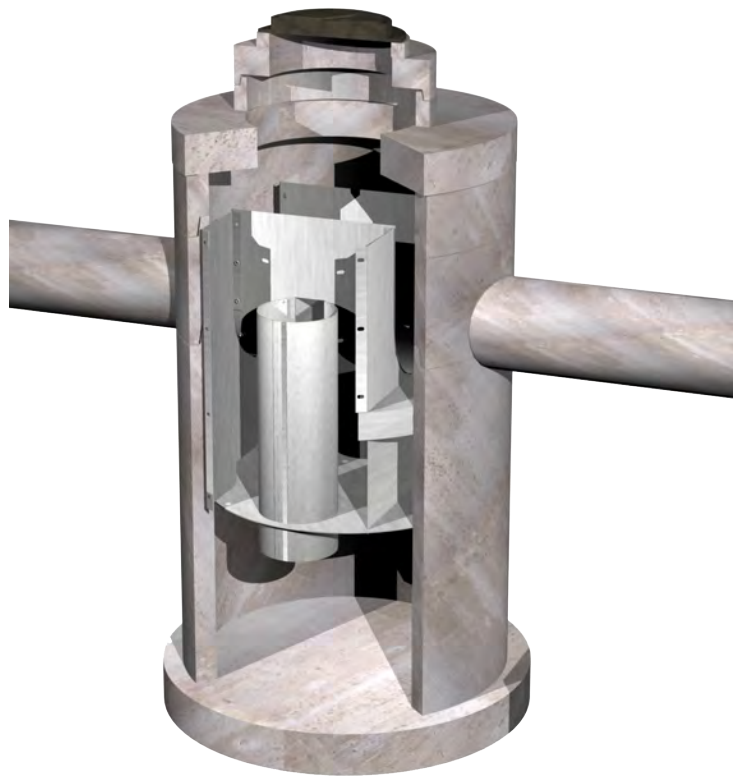

TABLE OF CONTENTS

1 - Submittal Drawing

2 - Features & Benefits

3 - Product Specifications

4 - Inspection & Maintenance

SECTION 1

Submittal Drawing

SECTION 2

Features & Benefits



STORM CYCLONIC WATER Separation

Enhanced Gravity Separation of Stormwater Pollutants in a Compact Configuration

Dual-Vortex Efficiency

Particle settling is enhanced by circular flow patterns and a highly circuitous flow path created by two independent vortex cylinders.

Settled particles are collected in the isolated bottom storage area, while floating trash, debris and petroleum hydrocarbons are retained in the cylinders and upper storage areas.

During peak events, flows in excess of design treatment overtop the bypass weir and exit the system without entering the cylinders and lower storage area, thereby eliminating re-entrainment issues.

FEATURES:

- Maintenance Accessible Design
- Economical Installation
- Access Options
- Online System Capability
- Durable Construction
- Proven Performance
- Treatment Train

BENEFITS:

- Open access to accumulated floatables and sediment storage area
- Prepackaged and provided as compact round or square manholes
- Multiple access options (manhole cover or optional hinged lid)
- Internal high-flow bypass weir system provides for online or offline configurations
- Stainless-steel components installed in a reinforced concrete structure
- Third party tested and certified
- Can be installed upstream of infiltration, detention and retention systems or other treatment BMP's

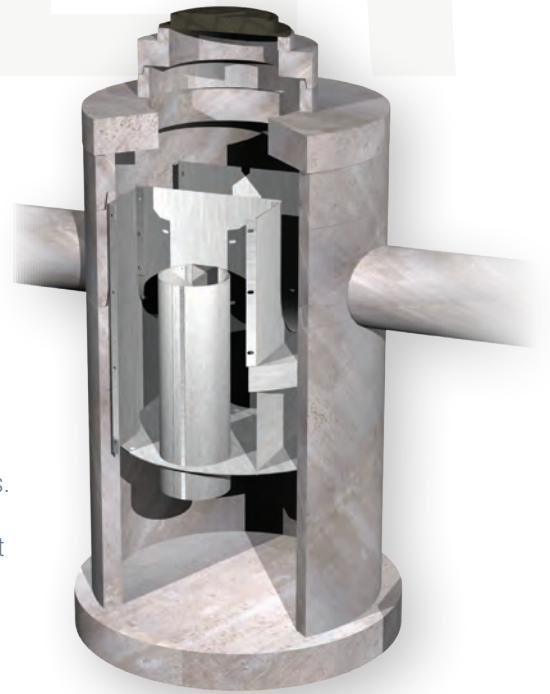

Dual-Vortex Separator Offers an Innovative, Economical Alternative for Removal of Suspended Pollutants from Stormwater Runoff

How it Works

STEP 1

Independent Vortex Cylinders & Control Weir - Flows are directed to the two independent vortex cylinders where particle settling is enhanced by circular flow patterns.

STEP 2

Captured Floatables - Floating trash, debris and petroleum hydrocarbons accumulate at the top of the two cylinders where they are held until transfer into the upper storage area by peak storm events.

STEP 3

Removal of Total Suspended Solids (TSS) - Particle settling is enhanced by the circular flow patterns and a highly circuitous flow path created by two independent vortex cylinders. Sediments are collected and retained in the isolated bottom storage area.

STEP 4

High-Flow Bypass - Flows in excess of the design treatment overtop the bypass weir and exit the system without entering the cylinders and re-entraining captured pollutants.

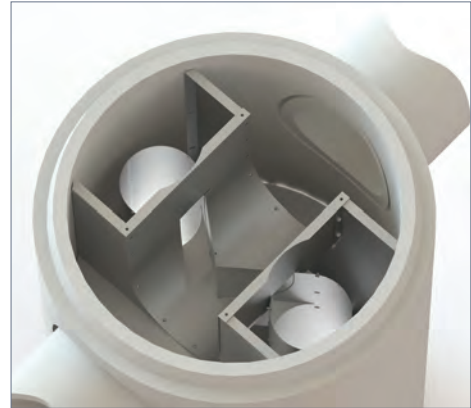

MODELS AND NOMINAL DIMENSIONS

Model No.	Structure Diameter (ft.)	Standard Sump Depth* (ft.)	Minimum Rim to Invert Depth (ft.)	Sediment Storage* (cubic feet)	Oil and Floatable Storage (cubic feet)	NJCAT Treatment Flow Rate (cfs)	Maximum Treatment Flow Rate (cfs)
DVS-36	3	4.5	2.5	11	6	0.56	0.56
DVS-48	4	5.0	3.0	19	15	1.00	1.25
DVS-60	5	5.5	3.5	29	29	1.56	2.50
DVS-72	6	6.5	4.5	42	49	2.25	4.25
DVS-84	7	7.0	5.0	58	79	3.06	6.50
DVS-96	8	8.0	5.5	75	116	4.00	9.50
DVS-120	10	10.0	7.0	118	226	6.25	16.80
DVS-144	12	11.5	8.0	170	388	9.00	26.40

*Depth of unit can be increased to add storage capacity.

Available Options

Square configurations accept multiple inlet pipes or meet other special site conditions.
 Flume inlet control for grated inlet applications.



SECTION 3

Product Specifications

PART 1 — GENERAL

1.1 Section Includes

- A. Dual Vortex Separator (DVS) – vortex hydrodynamic separator for stormwater treatment.

1.2 Related Sections

- A. Section 01 33 00 – Submittals: Shop Drawings, Product Data, and Samples
- B. Section 02 30 00 – Earthwork: Excavation, Trenching, Backfill, and Compaction.
- C. Section 31 25 00 – Erosion and Sedimentation Controls

1.3 References

- A. American Association of State Highway and Transportation Officials (AASHTO)
 - 1. AASHTO M105 – Standard Specification for Gray Iron Castings
- B. American Society for Testing and Materials (ASTM)
 - 1. ASTM A48, CL.30B – Standard Specification for Gray Iron Castings
 - 2. ASTM A82 – Standard Specification for Steel Wire, Plain, for Concrete Reinforcement
 - 3. ASTM A185 – Standard Specification for Welded Steel Wire Fabric for Concrete Reinforcement
 - 4. ASTM A240 – Standard Specification for Chromium and Chromium-Nickel Stainless Steel Plate, Sheet, and Strip for Pressure Vessels and for General Applications
 - 5. ASTM A496 – Standard Specification for Deformed Steel Wire for Concrete Reinforcement
 - 6. ASTM A497 – Standard Specification for Steel Welded Wire Reinforcement, Deformed, for Concrete
 - 7. ASTM A615 – Standard Specification for Deformed and Plain, Carbon-Steel Bars for Concrete Reinforcement
 - 8. ASTM B209 – Standard Specification for Aluminum and Aluminum-Alloy Sheet and Plate
 - 9. ASTM C32 – Standard Specification for Sewer and Manhole Brick (Made from Clay or Shale)
 - 10. ASTM C33 – Standard Specification for Concrete Aggregates
 - 11. ASTM C139 – Standard Specification for Concrete Masonry Units for Construction of Catch Basins and Manholes

12. ASTM C150 – Standard Specification for Portland Cement
13. ASTM C478 – Standard Specification for Circular Precast Reinforced Concrete Manhole Sections
14. ASTM C595 – Standard Specification for Blended Hydraulic Cements
15. ASTM C890 – Standard Practice for Minimum Structural Design Loading for Monolithic or Sectional Precast Concrete Water and Wastewater Structures
16. ASTM C891 – Standard Practice for Installation of Underground Precast Concrete Utility Structures
17. ASTM C913 – Standard Specification for Precast Concrete Water and Wastewater Structures
18. ASTM C990 – Standard Specification for Joints for Concrete Pipe, Manholes, and Precast Box Sections Using Preformed Flexible Joint Sealants
19. ASTM C1107 – Standard Specification for Packaged Dry, Hydraulic Cement Grout (Non-Shrink)
20. ASTM C1227 – Standard Specification for Precast Concrete Septic Tanks
21. ASTM C1244 – Standard Test Method for Concrete Sewer Manholes by the Negative Air Pressure (Vacuum) Test Prior to Backfill
22. ASTM D698 – Standard Test Methods for Laboratory Compaction Characteristics of Soil Using Standard Effort

C. Definitions:

1. BMP: Best Management Practices
2. TSS: Total Suspended Solids

1.4 Submittals

The following shall be submitted by contractor in accordance with Section 01 33 00 Submittal Procedures:

A. Product Data for the Hydrodynamic Separator:

1. Product specifications to include but not limited to specification sheets, brochures, and performance claims.
2. Inspection and maintenance guidelines.
3. Submittal drawings shall be provided and annotated to indicate all materials to be used and applicable material standards, required tests of materials, and all design assumptions for structural analysis. Details of steel reinforcing size and placement shall be submitted if professional

engineering stamp and calculations are required by the customer. It is the responsibility of the project's engineer-of-record to verify that the design assumptions are suitable for the proposed application.

- B. Independent third-party certification or test report demonstrating conformance to applicable local or regional BMP standards before the treatment system is installed for the following, upon request:
 - 1. Removal Efficiency
 - 2. Targeted Pollutants of Concern
 - 3. Hydraulic Capacity
 - 4. Certification of adherence to applicable standard
- C. Products submitted as approved equal must be submitted at least 2 weeks prior to project bid opening and must be approved by project engineer. Submittal for approved equal product must contain a signed letter from an executive officer of the manufacturer stating product is equivalent to all applicable requirements of this specification.

1.5 Quality Assurance

The precast concrete producer shall demonstrate adherence to the standards set forth in the plant Quality Control Manual.

- A. Qualifications, Quality Control and Inspection
 - 1. The precast producer shall maintain a permanent quality control department.
 - 2. The precast concrete producer shall have a quality control program which is audited for compliance annually by persons outside that plant's employee structure.
 - 3. Upon request, the precast concrete producer shall supply a copy of their quality control manual.
- B. Quality Control
 - 1. The precast concrete producer shall perform standard concrete testing and inspection.
 - i. Preplacement Check
 - 1. All non machine-cast products shall be inspected for accuracy prior to placing concrete. Checks shall include, but not be limited to, form condition and cleanliness, form dimensions, joints, release agent, blockouts, inserts and locations, lifting devices, reinforcing steel size, spacing, clearances and proper placement. Machine cast products shall have a minimum 5% of the production checked at random.
 - 2. Preplacement checks shall be documented and initialed by the inspector. A drawing with verifications of the above

criteria can be used as documentation.

ii. Postplacement Check

1. All non machine-cast products shall be inspected for accuracy after the concrete forms have been removed. Checks shall include, but not be limited to, dimensional checks, finishing, insert locations, squareness, honeycombing, cracking, marking, coatings, racking, hole size and location. Postplacement checks may require a corrective action report. Machine cast products shall have a minimum of 5% of production checked at random.
2. Postplacement checks shall be documented and initialed by the inspector. A drawing with verifications of the above criteria can be used as documentation.

2. Copies of the test results and Inspections above shall be available upon request.

1.6 Delivery, Storage, and Handling

- A. All treatment system components shall be delivered to the site and unloaded with handling that conforms to the manufacturer's instructions for reasonable care. Concrete and internal components shall not be rolled or dragged over gravel or rock during handling. The contractor shall take necessary precautions to ensure the method used in lifting or placing the treatment system does not induce stress fatigue in the concrete.

PART 2 — PRODUCTS

2.1 Description

The contractor, and/or a manufacturer selected by the contractor and approved by the Engineer, shall furnish all labor, materials, equipment and incidentals required and install all precast concrete stormwater treatment systems and appurtenances in accordance with the drawings and these specifications. The treatment system is housed in a precast concrete manhole or vault structure. The treatment system shall provide flow partitioned hydrodynamic treatment that removes sediment, free-floating pollutants, and oil particles. The treatment system must include the capability to partition flows, causing treatment flows to be diverted into the treatment chamber. Flows exceeding the treatment capacity of the unit shall divert the bypass flows around the treatment chamber to prevent resuspension and washout of previously trapped pollutants.

2.2 Materials and Design

- A. Concrete for precast stormwater treatment systems shall conform to ASTM A478 or ASTM C890 and C913 and meet the following additional requirements:
 1. In all cases the wall thickness shall be no less than the minimum thickness necessary to sustain HS20-44 (MS18) loading requirements as determined by a Licensed Professional Engineer.
 2. Sections shall have tongue and groove or ship-lap joints with a butyl

mastic sealant conforming to ASTM C990.

3. Cement shall be Type I, II, or III Portland cement conforming to ASTM C150.
4. All sections shall be cured by an approved method. Sections shall not be shipped until the concrete has attained a compressive strength of 4,000 psi (28 MPa) or other designate suitable handling strength.
5. Pipe openings shall be sized to accept pipes of the specified size(s) and material(s), and shall be sealed by the contractor with hydraulic cement conforming to ASTM C595M or ASTM C1107.
6. Aggregates shall conform to ASTM C33, except that the requirement for gradation shall not apply.
7. Reinforcement shall consist of wire conforming to ASTM A82 or A496, of wire mesh conforming to ASTM A185 or A497, or Grade 40 steel bars conforming to ASTM A615.
8. Castings for manhole frames and covers shall be in accordance with ASTM A48, CL.30B and AASHTO M105. The access cover/s shall be designed for HS20-44 traffic loading and shall provide a minimum of 30-inch clear opening.
9. Brick or masonry used to build the manhole frame to grade shall conform to ASTM C32 or ASTM C139 and shall be installed in conformance with all local requirements.
10. Diversion weirs, separation chamber, and oil baffle shall be made from aluminum and/or stainless steel and shall conform to ASTM B209 or ASTM A240
11. All mounting hardware for internal components shall be made of 304SS and shall conform to ASTM A240

2.3 Performance

Each specified stormwater flow based treatment device shall conform to the specifications listed in Table 2.1

Table 2.1 DVS Models, Flow Rates and Capacities.

DVS Model	Diameter or Length/Width (ft)	NJCAT Verified Flow Rate (cfs)	Minimum Sediment Storage Capacity (cu-ft)	Minimum Oil Storage Capacity (cu-ft)
DVS-36	3	0.56	11	5
DVS-48	4	1.00	19	12
DVS-60	5	1.56	29	23
DVS-72	6	2.25	42	37
DVS-84	7	3.06	58	60
DVS-96	8	4.00	75	88
DVS-120	10	6.25	118	184
DVS-144	12	9.00	170	312

Each specified flow-based stormwater treatment system shall be verified by New Jersey Corporation for Advanced Technology (NJCAT) and certified by New Jersey Department of Environmental Protection (NJDEP) according to the 2013 Hydrodynamic Separator Testing Protocol. Each specified flow-based stormwater treatment system shall be capable of removing 50% of the weighted Total Suspended Solids (TSS) load based on a d50 particle size of 47 microns. Annual TSS removal efficiency models shall be based on laboratory performance data, site-specific hydraulics and hydrology, and local rainfall intensity distributions. The stormwater treatment system shall be completely housed within one structure.

2.4 Manufacturer

Each stormwater treatment system shall be a Dual Vortex Separator (DVS) as manufactured by Oldcastle Infrastructure, Inc., 7100 Longe St, Stockton, California 95206. Phone: (800) 579-8819.

PART 3 — EXECUTION

3.1 Survey

- A. The installation area shall be surveyed using the work print and a checklist to identify the work to be done and to determine that the plans are correct.
- B. All underground facilities and structures such as gas, water, sewer, power, telephone cable, and so forth shall be located and identified. Location markings shall be placed by the affected utilities before construction.
- C. The survey shall identify and obstacles such as overhead wires, building structures that will interfere with crane operations, work progress, or create a safety hazard.
- D. The survey shall give consideration to the soil structure so that proper shoring, sloping, or both may be planned in advance of the excavation work.

3.2 Planning

- A. Permits required to do work in accordance with the detail plans shall be secured before starting the job. All permits or a record of the permits shall be retained on the

job for immediate reference.

- B. All utilities and owners of surface and subsurface facilities and structures in the area shall be given advance notification of proposed excavation. Every effort shall be made to avoid damage to the facilities of others. If any damage occurs, the owner of the damaged facility shall be notified immediately.
- C. Planning shall include the coordination of all responsible parties to ensure that arrangements for removal of excess and damaged material have been made.
- D. Should it appear that a structure location will interfere with traffic, review the situation with the engineer and notify appropriate authorities.
- E. Provide for access to call boxes, fire hydrants, etc.

3.3 Safety Requirements

- A. Safety requirements for construction shall be in accordance with all federal, state, and local regulations.

3.4 Excavating

- A. If unforeseen facilities or obstructions are encountered, stop excavation operations immediately. Expose the obstruction with wood handled digging tools and investigate them with caution. If there is any doubt as to the type of obstruction exposed, request positive identification from those suspected of owning the facility and then proceed as circumstances dictate.
- B. Inspect excavations after every rainstorm or other hazard-increasing occurrence, and increase the protection against slides and cave-ins, if necessary.
- C. In dewatering excavations, make certain that the discharge is carried to a suitable runoff point.
- D. Excavation size shall be large enough to allow access around the structure after it is installed.

3.5 Shoring

- A. Shoring for construction shall be in accordance with all federal, state, and local regulations

3.6 Installation

- A. Site Access – The general contractor shall be responsible for providing adequate access to the site to facilitate hauling, storage, and proper handling of the precast concrete units.
- B. Installation – Precast concrete units shall be installed: to the lines and grades shown on the contract documents or otherwise specified; be lifted by suitable lifting devices at points provided by the precast concrete producer; in accordance with applicable industry standards. Upon request, the precast concrete producer shall provide installation instructions. Field modifications to the product shall relieve the precast

producer of liability and warranty regardless if such modifications result in the failure of the precast concrete unit.

- C. Leak Resistance – Where leak resistance is a necessary performance characteristic of the precast concrete unit's end use, joint sealant, pipe-entry connectors and other penetrations shall be sealed according to manufacturer's requirements to ensure the integrity of the system.

3.7 Backfilling and Restoration

- A. Do the backfilling as soon as possible after the structure has been placed.
- B. Backfill material shall be granular and free from large stones, rocks, and pavement. Expansive soil material shall not be used as backfill around the structure.
- C. Backfilling shall be achieved by lifts (layers) to the required compaction.
- D. Follow up inspections for settlements are required. Should settlement occur, the contractor shall be responsible for all necessary repairs.

3.8 Field Quality Control

- A. Job Site Tests – When leak resistance testing is required for a precast concrete structure, one of the following methods may be followed:
 - 1. Vacuum Testing
 - i. Prior to backfill, vacuum test system according to ASTM C1244 for manholes and ASTM C1227 for septic tanks.
 - 2. Hydrostatic Testing
 - i. First Backfill the structure, then fill to the normal water level, let stand for 24 hours. Refill to the original water line and measure the water level change over a 24-hour period. Leak shall not exceed 5% of volume.
- B. Inspection
 - 1. Final field elevations and compaction properties shall be verified and documented.

END OF SECTION

SECTION 4

Inspection & Maintenance



DUAL-VORTEX SEPARATOR

Inspection and Maintenance Guide

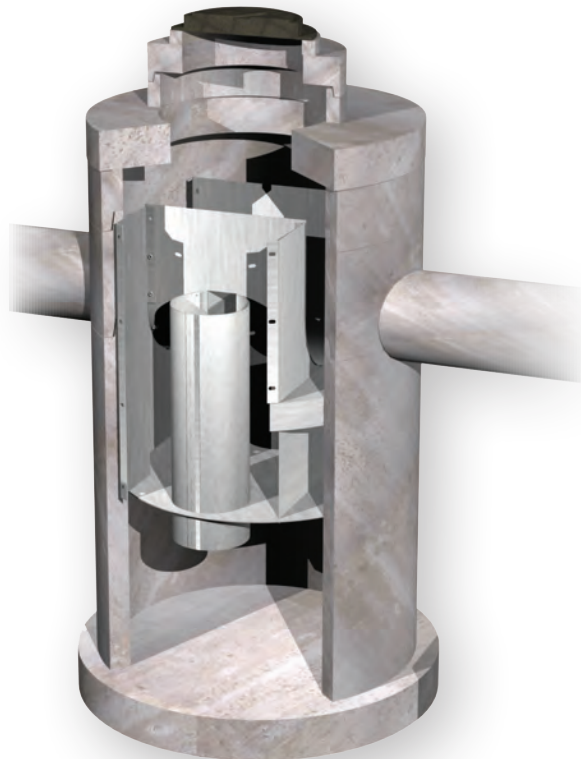

Description

The Dual-Vortex Separator (DVS) is a hydrodynamic stormwater treatment device used to remove pollutants from urban runoff. Impervious surfaces and other urban and suburban landscapes generate a variety of contaminants that can enter stormwater and pollute downstream receiving waters. The DVS is designed to capture and retain sediment as well as floating trash, debris and oils. The concentration of metals and other constituents associated with sediment or floating pollutants may also be reduced.

Function

Stormwater runoff enters the DVS unit through an inlet pipe. Influent flow is split evenly between two vortex tubes by a V-shaped weir. The shape and diameter of the vortex tubes promotes circular motion of the incoming stormwater at increased velocities to enhance particle settling through centrifugal force. The system is also designed with an extended flow path to maximize hydraulic residence time which allows increased time to settle out solids. Settled pollutants are collected in an isolated storage area at the bottom of the structure, while floating trash, debris and petroleum hydrocarbons are retained behind baffles that contain the vortex chambers. During peak runoff events, flow in excess of design treatment flow overtops the bypass weir and exits the system without entering the treatment chambers to interrupt the treatment process or re-entrain captured pollutants. Treatment and bypass flows exit the system through an outlet pipe that is plumbed at the same elevation as the inlet pipe.

Configuration

The internal components of the DVS system are fabricated from stainless steel and mounted in a manhole or vault structure. The system is typically delivered as a complete unit for installation by the contractor. Installation includes excavation, preparation of the base rock, setting the unit, plumbing the inlet and outlet piping, backfill and placement of the finished surface at grade. Access to the installed system is allowed through ductile iron casting or hatch covers. The number of access points provided is dependent on the size and configuration of the system.

Maintenance Overview

State and local regulations require all stormwater management systems to be inspected on a regular basis and maintained as necessary to ensure performance and protect downstream receiving waters. Without maintenance, excessive pollutant buildup can limit system performance by reducing the operating capacity and increase the potential for scouring of pollutants during periods of high flow.

Inspection Equipment

The following equipment is helpful when conducting DVS inspections:

- Recording device (pen and paper form, voice recorder, iPad, etc.)
- Suitable clothing (appropriate footwear, gloves, hardhat, safety glasses, etc.)
- Traffic control equipment (cones, barricades, signage, flagging, etc.)
- Manhole hook or pry bar
- Flashlight
- Tape measure
- Measuring stick or sludge sampler
- Long-handled net (optional)
- Replacement sorbent pads

Inspection Procedures

Inspection is essential to consistent system performance and is easily completed. Inspection is typically conducted a minimum of twice per year but since pollutant transport and deposition varies from site to site, a site-specific maintenance frequency should be established during the first two or three years of operation.

DVS inspections are visual and are conducted without entering the unit. To complete an inspection, safety measures including traffic control should be deployed before the access covers are removed. Once the covers have been removed, the following items should be checked and recorded (see form provided on page 5) to determine whether maintenance is required:

- Inspect the internal components and note whether there are any broken or missing parts. In the unlikely event that internal parts are broken or missing, contact Oldcastle Infrastructure at (800) 579-8819 to determine appropriate corrective action.
 - Note whether the inlet or outlet pipe is blocked or obstructed.
 - Observe, quantify and record the accumulation of floating trash and debris in the baffled chambers around the vortex tubes. The significance of accumulated floating trash and debris is a matter of judgement. A long-handled net may be used to retrieve the bulk of trash and debris at the time of inspection if full maintenance due to accumulation of oils or sediment is not yet warranted.
 - Observe, quantify and record the accumulation of oils in the baffled chambers around the vortex tubes. If sorbent pads have been used to absorb free oil and grease, observe and record their condition. Unless the sorbent pads are tethered to the internal baffles, spent pads may be netted and replaced at the time of inspection. The significance of accumulated floating oils is a matter of judgement. However, if there is evidence of an oil or fuel spill, immediate maintenance is warranted.
 - Finally, observe, quantify and record the accumulation of sediment in the sediment storage sump. A calibrated dipstick, tape measure or sludge sampler may be used to determine the amount of accumulated sediment. The depth of sediment may be determined by calculating the difference between the measurement from the rim of the DVS to the top of the accumulated sediment and the measurement from the rim of the DVS to the bottom of the DVS structure. Finding the top of the accumulated sediment takes some practice and a light touch, but increasing resistance as the measuring device is lowered toward the bottom of the unit indicates the top of the accumulated sediment.
-

Maintenance

Maintenance should be scheduled if any of the following conditions are identified during inspection:

- Internal components are broken or missing.
- Inlet or outlet piping is obstructed.
- The accumulation of floating trash and debris that cannot be retrieved with a net and/or oil in the baffled chambers around the vortex tubes is significant.
- Tethered sorbent pads, if used, are dirty or saturated.
- The sediment level in the sediment storage sump is greater than 12 inches. The capacity of the sediment sump is 18 inches of sediment depth for all DVS models. Sediment depths greater than 18 inches will begin to affect the performance of the system.

Maintenance Equipment

The following equipment is helpful when conducting DVS maintenance:

- Suitable clothing (appropriate footwear, gloves, hardhat, safety glasses, etc.)
- Traffic control equipment (cones, barricades, signage, flagging, etc.)
- Manhole hook or pry bar
- Confined space entry equipment, if needed
- Flashlight
- Tape measure
- Sorbent pads
- Vacuum truck

Maintenance Procedures

Maintenance should be conducted during dry weather when no flow is entering the system. All maintenance, except possibly the attachment of sorbent pads (if required), may be conducted without entering the DVS structure. Once safety measures such as traffic control are deployed, the access covers may be removed and the following activities may be conducted to complete maintenance:

- Remove floating trash, debris and oils from the water surface using an extension on the end of the boom hose of the vacuum truck. Continue using the vacuum truck to completely dewater the structure through the vortex tubes and evacuate all accumulated sediment from the sediment sump. Some jetting may be required to fully evacuate sediment from the sump. This is easily achieved by inserting a jet hose through the vortex tube opposite the tube used for vacuum hose access.
 - If sorbent pads are required and are tethered to the structure, only personnel that are OSHA Confined Space Entry trained and certified may enter the structure to remove and replace the spent pads.
 - The structure does not need to be refilled with water after maintenance is complete. The system will fill with water when the next storm event occurs.
 - All material removed from the DVS during maintenance must be disposed of in accordance with local regulations. In most cases, the material may be handled in the same manner as disposal of material removed from sumped catch basins or manholes.
-

Dual-Vortex Separator Inspection and Maintenance Log

DVS Model _____

Inspection Date _____

Location _____

Condition of Internal Components

Notes:

Good Damaged Missing

Inlet or Outlet Blockage or Obstruction

Notes:

Yes No

Floating Trash and Debris

Notes:

Significant Not Significant

Floating Oils

Notes:

Significant Not Significant Spill

Sediment Depth

Notes:

Inches of Sediment: _____

Maintenance Requirements

Yes - Schedule Maintenance No - Schedule Re-Inspection

DUAL-VORTEX SEPARATOR

OUR MARKETS



BUILDING
STRUCTURES



COMMUNICATIONS



WATER



ENERGY



TRANSPORTATION

NSBB[®] Nutrient Separating Baffle Box[®]

Operation and Maintenance Manual

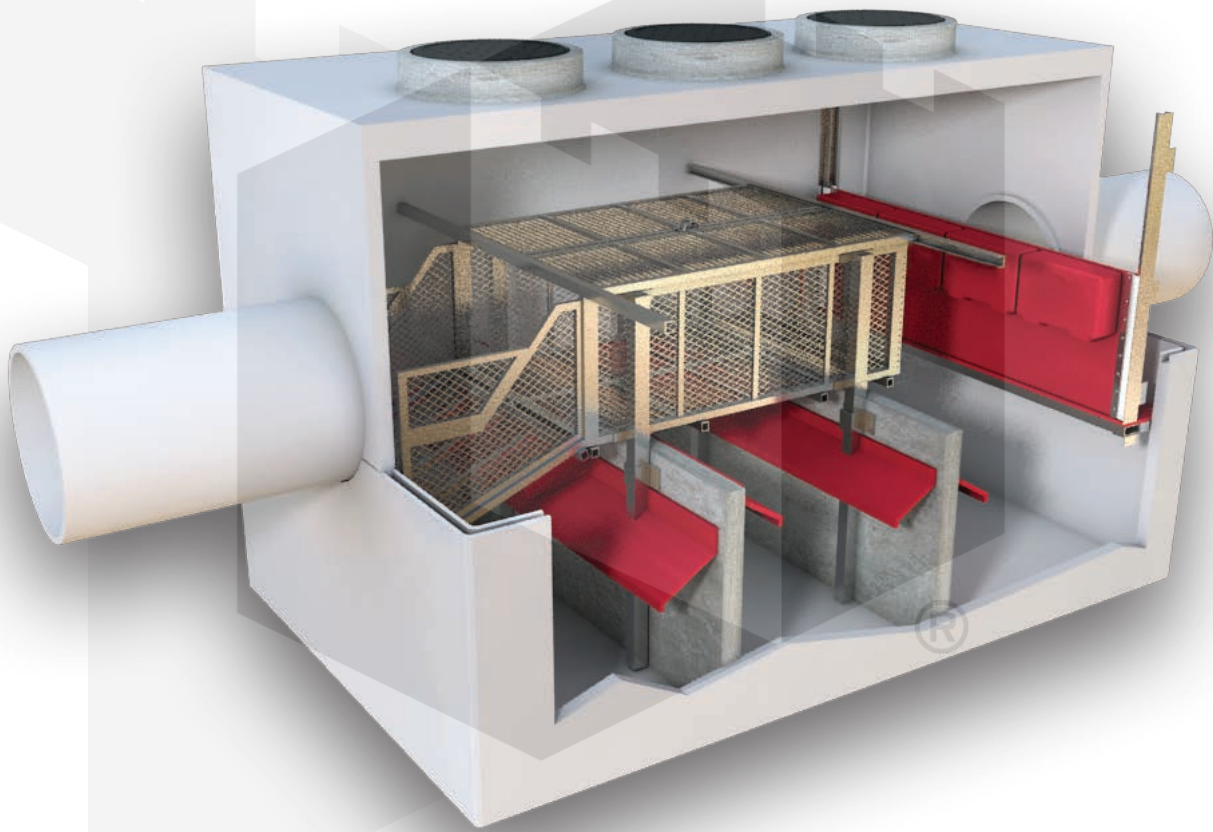

TABLE OF CONTENTS

WARNING	2
GENERAL INFORMATION	3
INSPECTION INFORMATION	4
INSPECTION CHECKLIST	5
NSBB® COMPONENTS	6
REQUIREMENTS AND PARTS	7
SERVICE SUMMARY	8
SCREEN MAINTENANCE	9
CHAMBER MAINTENANCE	10
POST SERVICING PROTOCOL	10
WARRANTY	11
CONTACT INFORMATION	11

WARNING

Read the Following Information, Instructions and Warnings Before Inspecting, Cleaning or Performing Maintenance on this Stormwater Treatment Device.

This manual is intended to explain the specifics of the Oldcastle Infrastructure Nutrient Separating Baffle Box and to review the aspects of existing regulations and safety procedures. It is the responsibility of all personnel to familiarize themselves with, understand and comply with all applicable local, state and federal laws before attempting to inspect or service this unit. All precautions and procedures in this manual are current at the time of printing but are subject to change based on the development of new processes and procedures. Oldcastle Infrastructure assumes no responsibility and is not accountable for any injuries, fines, penalties or losses that occur involving any procedure in this manual or other unaddressable actions taken. The Nutrient Separating Baffle Box performance is based on the procedures being followed in this manual. Non-Compliance with the outlined measures will be the responsibility of the owner.

GENERAL INFORMATION

The Nutrient Separating Baffle Box (NSBB) is a key component of your stormwater management program. To maintain proper operation, maintenance of these units is essential. The NSBB designed and manufactured by Oldcastle Infrastructure contains patented technologies to treat and manage stormwater. The NSBB is highly effective in capturing Nitrogen, Phosphorus, Total Suspended Solids, organics, trash, oils and grease. Independent testing has shown the NSBB is capable of capturing up to 95% of trash, 90% of Total Suspended Solids, 20% of nitrogen and 19% of phosphorus. Oldcastle Infrastructure recommends inspections be conducted semi-annually for the first year and annually thereafter for optimal removal efficiency.

During Storm Event

Nutrient rich organics and litter are captured in the screen system.

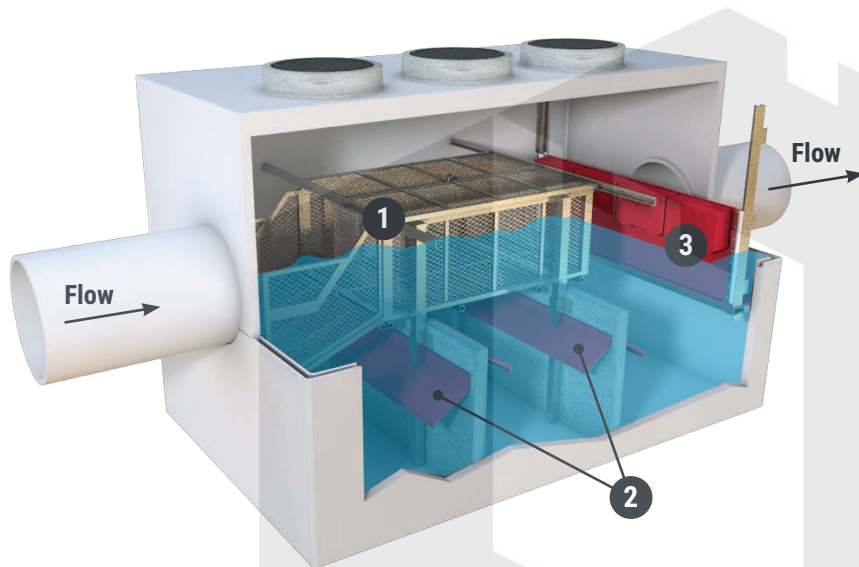

1. Runoff filters through the screen and skimmer leaving pollutants behind. Left over runoff evaporates over time.
2. Turbulence deflectors prevent captured sediment from becoming resuspended.
3. Hydrocarbons and other floating debris are trapped upstream of the floating skimmer.

After Storm Event

Debris dry out between storm events while pollutants are stored above the static water. As a result, the system does not turn septic.

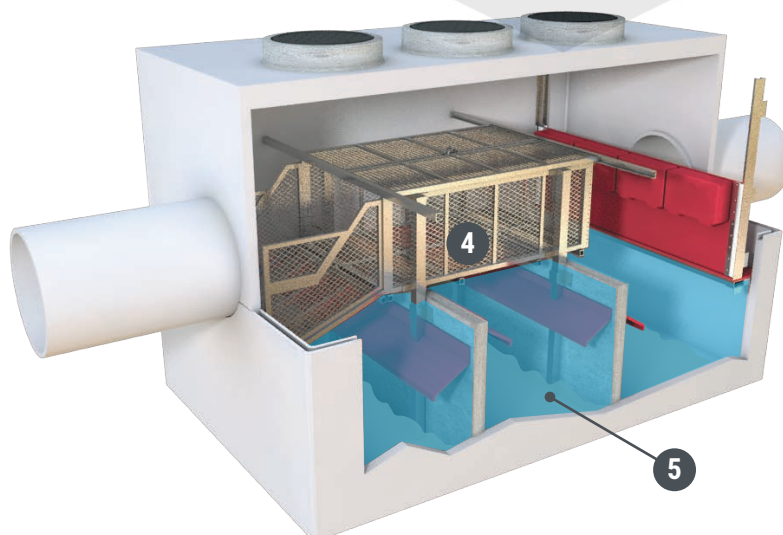

4. Nutrient pollutant load is not lost to static water and will not be flushed out during the next storm event.
5. Separating organic matter from the static water prevents bacterial buildup.

INSPECTION INFORMATION

Oldcastle Infrastructure recommends the following guidelines for inspection: After installation and the site has stabilized, post construction inspections should be conducted after every runoff event. To ensure the Nutrient Separating Baffle Box obtains optimal pollutant removal efficiencies, subsequent sediment accumulation inspections should be conducted a minimum of every six (6) months. In the event the sediment accumulation equals or exceeds 80% of the minimum sediment storage volume (Fig 1), then all accumulated sediment must be removed.

Fig 1: Nutrient Separating Baffle Box® (NSBB®) Sizing Summary

STANDARD SIZING								
MODEL	STRUCTURE SIZE (FT X FT)	MAX PIPE SIZE (IN)	MIN RIM TO INVERT DEPTH ^(a) (FT)	SUMP DEPTH (FT)	SEDIMENT STORAGE ^(b) (CF)	TREATMENT FLOW RATES		MAX PEAK FLOW ^(e) (CFS)
						50% REMOVAL, 75 MICRON NJCAT ^(c) (CFS)	80% REMOVAL, 150 MICRON ^(d) (CFS)	
NSBB-48	4 x 8	24	4.17	3.0	15.0	2.49	4.60	29
NSBB-510	5 x 10	30	5.08	4.1	23.8	3.89	8.03	37
NSBB-612	6 x 12	36	5.17	5.0	34.3	5.60	12.70	69
NSBB-816	8 x 16	48	6.00	6.2	61.3	9.96	26.00	114
NSBB-1020	10 x 20	60	7.08	7.6	95.0	15.56	45.40	202
NSBB-1224	12 x 24	72	8.83	9.0	138.0	22.40	71.70	296

TRASH CAPTURE SIZING								
MODEL	STRUCTURE SIZE (FT X FT)	MAX PIPE SIZE (IN)	MIN RIM TO INVERT DEPTH ^(a) (FT)	SUMP DEPTH (FT)	SUMP VOLUME (CF)	SCREEN VOLUME	5MM TRASH CAPTURE ^(f) (CFS)	MAX PEAK FLOW ^(g) (CFS)
NSBB-48-TC	4 x 8	24	4.17	3.0	88.1	25.8	28.80	25
NSBB-612-TC	6 x 12	36	5.17	3.0	204.1	54.5	42.80	64
NSBB-816-TC	8 x 16	48	6.00	3.0	360.0	124.6	72.00	108

(a) Minimum Rim to Invert Depth based on Max Pipe Size listed. For depths less than minimum contact Soln Engr for design assistance.

(b) Sump depth for all Trash Capture approved model sizes is 3.0' typical.

(c) 50% Maximum Sediment Storage Volume per NJCAT verification.

(d) Based on NJCAT verification for 50% removal of D50 = 75 micron.

(e) Based on AET Tech, LLC Technical Memo (Smith, 7/20/18). Contact Soln Engr for alternative particle size treatment flows.

(f) Based on empty 5mm Screen Basket.

(g) Based on a Hydraulic Grade Line at 6" above maximum pipe size. For smaller pipe sizes confirm capacity with Soln Engr.

INSPECTION PROCEDURE

- | Inspect the unit from surface.
- | Open access points (Manhole / Hatch) and secure properly.
- | Visually inspect screen system to determine overall debris accumulation.
- | Inspect sediment chambers under screen system.
- | Inspect condition of joints and inflow / outflow pipe grout areas.

INSPECTION CHECKLIST

Inspection Checklist and Maintenance Guidance: Nutrient Separating Baffle Box.
To be completed at Time of Inspection or Maintenance.

OWNER NAME

LOCATION

ADDRESS

PHONE

DATE & TIME

SITE CONDITIONS

INSPECTION ITEMS	RECOMMENDED INTERVAL	COMMENTS
Access Openings	Semi-annually	
Screen System	Semi-annually	
Skimmer	Semi-annually	
Sediment Chambers	Semi-annually	
Vault Condition	Semi-annually	

1. Inspection items are to determine accessibility into Nutrient Separating Baffle Box.
2. Inspect screen system for debris volume and broken parts.
3. Inspect sediment chambers for estimated quantity.
4. Inspect general condition of vault for any clogged areas.

MAINTENANCE ITEMS	VOLUME COLLECTED	DATE	COMMENTS
Screen System			
Sediment Chambers			

1. Inspection items are to determine accessibility into Nutrient Separating Baffle Box.
2. After cleaning screen system, open bottom doors and vacuum out sediment chambers. (Estimate Volume Collected)

NSBB[®] COMPONENTS

Component Descriptions

The Nutrient Separating Baffle Box is a multi stage, self contained treatment system. Each subsequent component in the system protects prior stages from clogging. These stages include screening, separation and hydrocarbon absorption.

- | Screening is provided by a rectangular basket system which is suspended above the static water level of the sedimentation chambers. The screening filter has a storage capacity of several cubic yards depending on the model. The primary function of the basket is to capture gross solids like trash and nutrient rich debris. The screening system contains debris and provides a dry storage state to prevent nutrient leaching and contamination of static water, causing a septic state.
- | Sediment Separation is facilitated by three settling chambers each with a capacity of several cubic yards depending on the model. These chambers work to target smaller sediments and particulate metals.



View of Nutrient Separating Baffle Box and SkimBoss Upflow Filter

REQUIREMENTS & PARTS

Minimum Equipment Requirements

The use of a vacuum truck is required for servicing of the Nutrient Separating Baffle Box. Service crews are recommended to check all local, state and federal guidelines for servicing and disposal of any collected debris and sediments.

Structural Components

The structural components of the NSBB are designed to have a life span of several decades. Structural inspections are not required unless stipulated in guidelines set by the local municipality, state or federal agencies.

Replacement Parts

All interior components are designed and sized to be assembled and removed from the NSBB for servicing or for parts replacement. This can easily be accomplished via the access ports atop the structure. For any replacement parts or further instructions please contact:

Oldcastle Infrastructure

7000 Central Parkway

Suite 800

Atlanta, GA 30328

Phone: (888) 965-3227

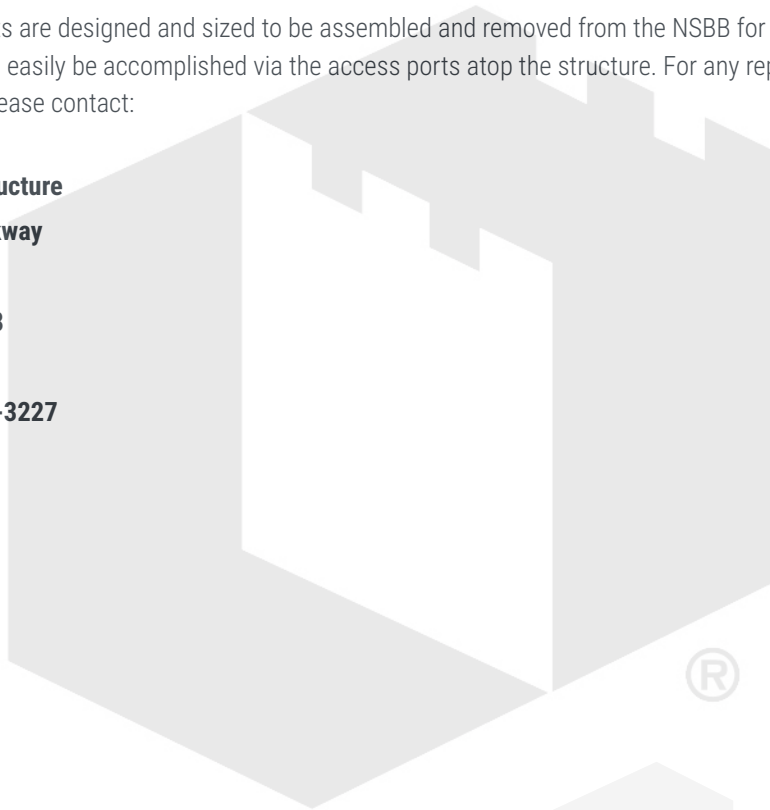

SERVICING SUMMARY

Service Information

Maintenance activities include the removal of captured sediments and debris. Maintenance can be performed from outside the NSBB through access points such as manhole covers or hatches installed in the vault surface above the sediment chambers. During maintenance, the screen system may have either SunGlide™ Sliding Doors or Hinged Doors.

These top doors open to gain access to the debris captured by the screen system. This system also has bottom doors that open to give access to the sediment collected in the settling chambers. A vacuum truck is required for debris and sediment removal. Although not every circumstance can be covered in this manual, a situation may arise where the structure needs to be entered. Servicing does not require specialized tools.

Caution!

Any Service Work done in traffic areas must meet all DOT Roadway Work guidelines and necessary safety procedures.

Warning!

All OSHA confined space requirements must be met while cleaning any of the Nutrient Separating Baffle Box structures.

Service Procedure

1. Open the access openings (Manhole, Hatch or Grate) on the top of the Baffle Box.
2. Vacuum the debris captured by the screen system to expose the sediment collection chambers.
3. Open the bottom doors to the basket system to expose the sediment collection chambers. These doors have eyebolts to attach the service tool in order to open the bottom doors which hinge off to the side.
4. Vacuum each sediment chamber until they are empty.
5. After cleaning the sediment chambers close the bottom screen doors of the screen system. Lower or Slide the top doors and assure they lock correctly (if equipped with SunGlide Lids).
6. When all maintenance work is completed, be sure to close the access covers or hatches.

Note

All vacuum servicing of NSBB components can be done with the use of any vacuum truck designed for catch basin cleaning.

When possible, maintenance should be performed from the surface level.

SCREEN MAINTENANCE

Screen Maintenance Procedure

The Nutrient Separating Baffle Box Screen Basket is recommended to be inspected every 6 months and cleaned every 12 months.

1. Remove all manhole covers (or open hatches or grates) to gain access to the screening basket.
2. Remove all trash, litter, debris, organics and sediments captured by the screened basket either manually or with the use of a vacuum truck. The vacuum hose will not damage the screen.
3. Remove vacuum hose and replace manhole covers or hatch doors.
4. Transport all debris, trash, litter, organics and sediments to an approved disposal facility in accordance with local and state requirements.

Note

The screen basket must be cleaned before vacuuming each sediment separation chamber.

The bottom of the screen basket is designed with three hinged panels that are lifted vertically to access each separation chamber.



Nutrient Separating Baffle Box with trash / debris collected inside the screening system basket.

CHAMBER MAINTENANCE

Separation Chamber Maintenance Procedure

The Nutrient Separating Baffle Box Hydrodynamic Separation Chambers are recommended to be inspected every six (6) months and cleaned every twelve (12) months.

1. Remove all manhole covers (or open hatches or grates) to gain access to the separation chambers.
2. Lower vacuum truck hose into the first separation chamber through the screening basket closest to the inflow pipe. Pressure washing may be needed to remove compacted sediments.
3. Repeat this process in each separation chamber.
4. Remove vacuum hose and lower hinged panels of screening basket back to a horizontal position.



Open lower screen panels to remove sediments via vacuum truck.

POST SERVICING PROTOCOL

After completing inspection or maintenance, the service operator should prepare a record of service. The record should include maintenance activities performed, amount and description of debris collected and system condition.

- | The owner will retain the service / inspection record for a minimum of five (5) years from the date of maintenance, or in accordance to specified EPA / DEP requirements.
- | All records should be made available to the governing municipalities for inspection upon request at any time.
- | Transport all debris, trash, litter, organics and sediments to an approved facility for disposal in accordance with local and state requirements.



Nutrient Separating Baffle Box with collected trash, organics and debris inside the screened basket system ready for disposal.

WARRANTY

Warranty Information

Oldcastle Infrastructure products are engineered and manufactured with the intent of being a permanent part of the infrastructure. Oldcastle Infrastructure warrants its products to be free from manufacturing defects for a period of 5 years from the purchase date. In the event a warranty claim is made and determined to be valid, Oldcastle Infrastructure will replace or repair the product at their own discretion. Warranty claims must be submitted, evaluated and approved by Oldcastle Infrastructure for the claim to be determined valid. All warranty work must be authorized by Oldcastle Infrastructure prior to work beginning not covered by this warranty. There are no warranties expressed or implied other than what is specified herein. Abusive treatment, neglect or improper use of the Nutrient Separating Baffle Box will not be covered by this warranty.

CONTACT INFORMATION

General Inquires

For additional information concerning installation, general usage, maintenance products, warranties or replacement parts please contact:

Oldcastle Infrastructure

7000 Central Parkway

Suite 800

Atlanta, GA 30328

Phone: (888) 965-3227



