

M:\LAND PROJECTS\2016\160301 - Judge Orr Road RV Park\DWG\160301 - Developed Conditions.dwg Jim.Cull Tue, 06/18/19 2:02 PM

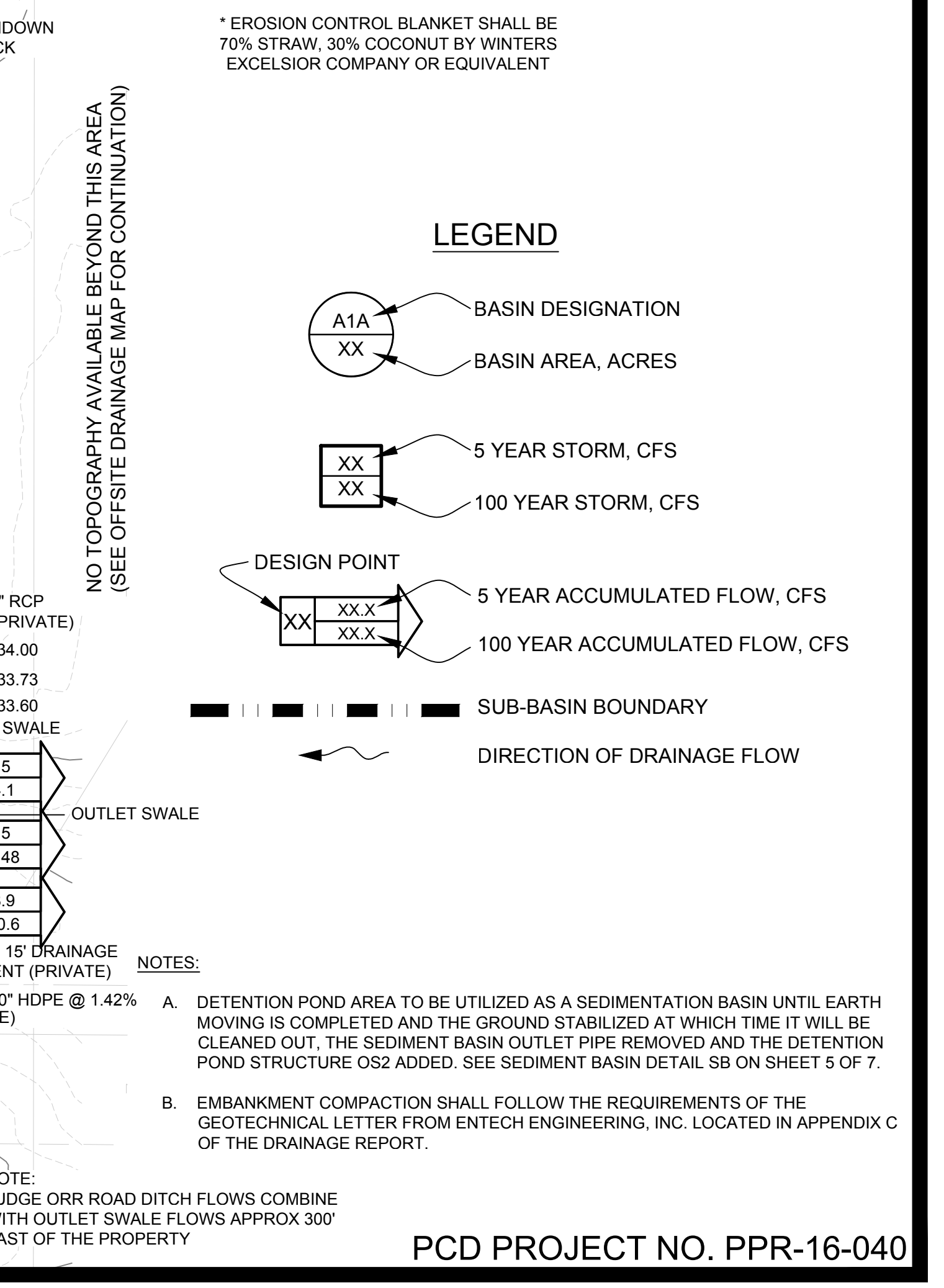
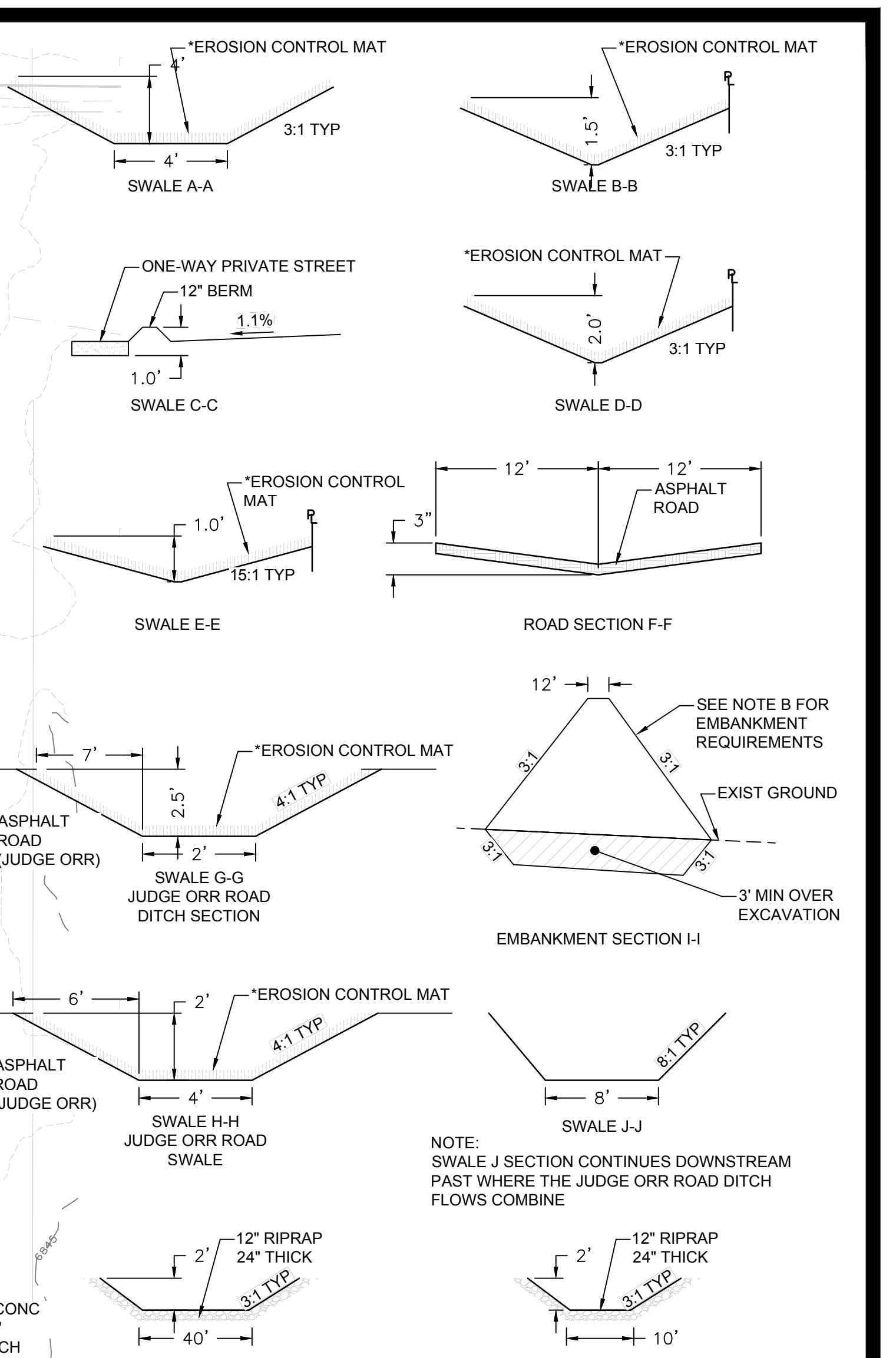
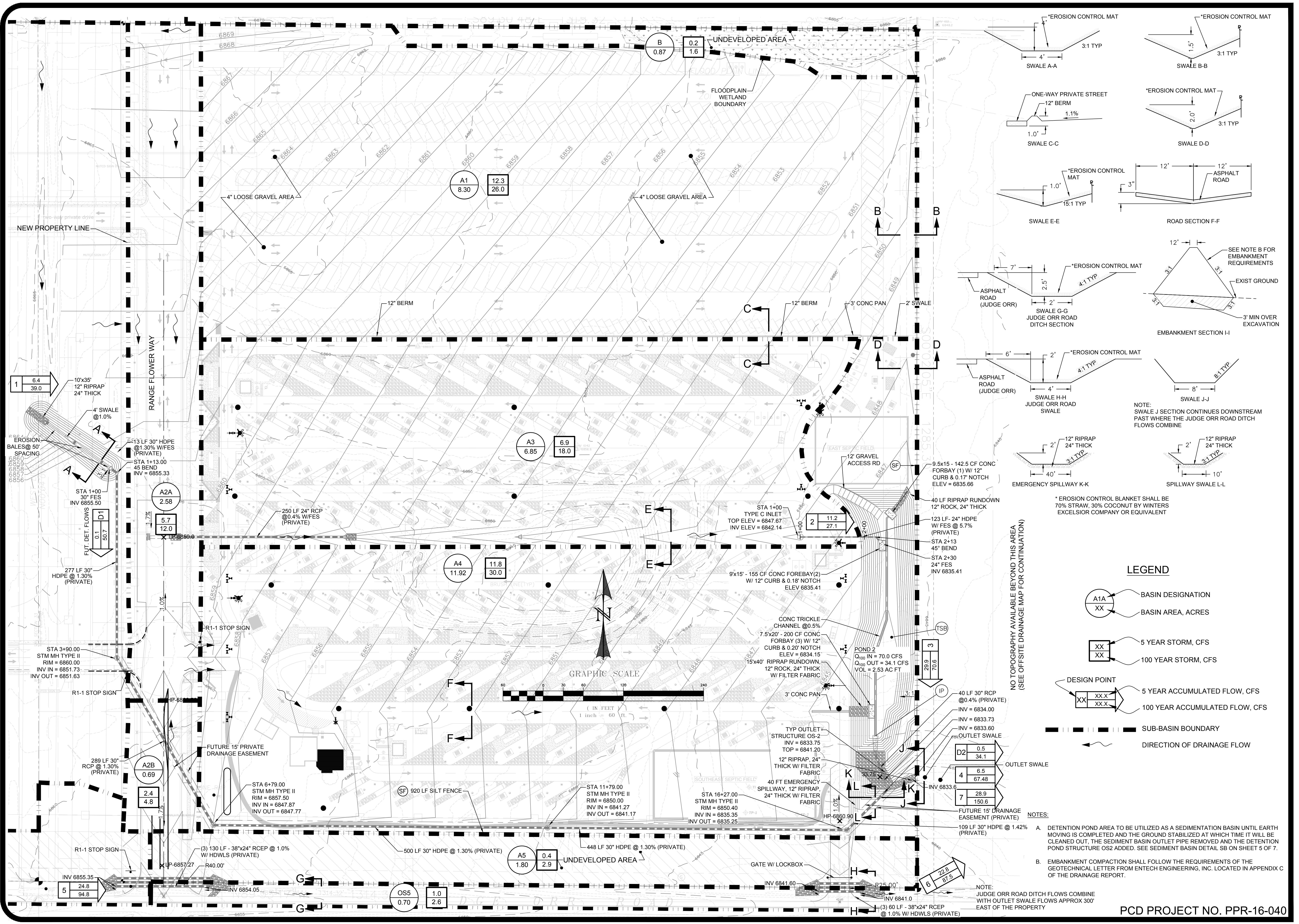

DESIGNED BY: MAB
PROJECT ENGINEER: MAB
PROJECT MANAGER: MAB
DATE: 02/05/19
JOB NO: 160301
CAD FILE NO: 160301-Dwg Cond
SCALE: 1" = 60'
DRAWN BY: HUG
VERT. N/A

PREPARED BY:

3520 Austin Bluffs Parkway
Suite 102
Colorado Springs, CO 80918
(719) 266-5212
fax: (719) 266-5341

NO.	DATE	REVISION

JUDGE ORR ROAD RV PARK & STORAGE

COLORADO SPRINGS, COLORADO

DRAINAGE - DEVELOPED CONDITIONS

SHEET

3 of 3

PCD PROJECT NO. PPR-16-040