



# STORMWATER MANAGEMENT PLAN (SWMP) FOR Falcon Highlands South

PCD File No. PUDSP-22-005

**Owner/Operator:**

Challenger Homes  
8605 Explorer Drive Ste. 250  
Colorado Springs, CO 80920  
Contact: Jim Byers  
Jim@challengerhomes.com  
719.598.5192 ext. 1006

**Engineer Contact:**

Atwell, LLC.  
Daniel Madruga, PE  
143 Union Blvd., Suite 700  
Lakewood, CO 80228  
dmadruga@atwell-group.com

**Qualified Stormwater Manager:**

George Hart  
Challenger Homes  
8605 Explorer Drive Ste. 250  
Colorado Springs, CO 80920  
GHart@challengerhomes.com  
970.567.0199

***SWMP Prepared by: Atwell, LLC***

SWMP Preparation Date: March 11, 2024

Estimated Project Dates:

Project Start Date: February 2024      Project Completion Date: December 2024

**Applicant:**

The Stormwater Management Plan was prepared under my direction and supervision and is correct to the best of my knowledge and belief. Said Plan has been prepared according to the criteria established by the County and State for Stormwater Management Plans.

\_\_\_\_\_  
Engineer of Record



\_\_\_\_\_  
Date

**Review Engineer:**

The Stormwater Management Plan was reviewed and found to meet the checklist requirements except where otherwise noted or allowed by an approved deviation request.

\_\_\_\_\_  
Review Engineer

\_\_\_\_\_  
Date

# Table of Contents

<b>SECTION 1: SITE EVALUATION, ASSESSMENT, AND PLANNING</b>	<b>5</b>
1.1 Project/Site Information	5
1.2 Contact Information/Responsible Parties	6
1.3 Nature and Sequence of Construction Activity	8
1.4 Construction Site Estimates	10
1.5 Soils, Drainage Patterns, and Vegetation	10
1.6 Anticipated Sources of Authorized Non-stormwater Discharge	11
1.7 Receiving Waters	11
1.8 Protected Site Features and Sensitive Areas	12
1.9 Potential Sources of Pollution	13
<b>SECTION 2: EROSION &amp; SEDIMENT CONTROL MEASURES</b>	<b>16</b>
2.1 Sediment Control Measures	17
2.2 Erosion Control Measures	18
2.3 Materials Management Control Measures	19
2.4 Site Management Control Measures	21
2.5 Structural Control Measures	22
<b>SECTION 3: CONSTRUCTION SITE PHASING &amp; ESC PLAN</b>	<b>23</b>
3.1 Construction Site Phasing Summary	23
3.2 General SWMP Notes	25
<b>SECTION 4: WASTE MANAGEMENT PLAN</b>	<b>28</b>
4.1 Covering Outdoor Storage and Handling Areas	28
4.2 Spill Prevention and Response Plan	29
4.3 Good Housekeeping	32
4.4 Vehicle Maintenance, Fueling and Storage	33
4.5 Street Sweeping and Cleaning	35
4.6 Storm Sewer Cleaning	36
<b>SECTION 5: FINAL STABILIZATION</b>	<b>37</b>
5.1 Final Stabilization Requirement	37
5.2 Final Stabilization Measures	37
5.3 Removal of Temporary CCMs	38
5.4 Stormwater Permits Close-out	38
5.5 Long Term Stormwater Management	38
<b>SECTION 6: STORMWATER INSPECTIONS</b>	<b>39</b>
6.1 Inspections	39
6.2 Inspection Sequence	41
<b>SECTION 7: RECORDKEEPING</b>	<b>43</b>
7.1 Recordkeeping	43

## SWMP APPENDIX

Appendix A: Sediment Basin Area Calculations and Details

Appendix B: Hydrologic Soils Group Map

Appendix C: FEMA Floodplain Map

Appendix D: QSM Qualifications

Appendix E: CDHPE Brochure

Appendix F: SWMP Amendment Log

Appendix G: GEC Plan Set and Details

**Objectives:**

The SWMP identifies possible pollutant sources that may contribute to stormwater pollution and identifies control measures (or BMPs) to reduce or eliminate potential water quality impacts during construction activities. The SWMP must be completed and implemented prior to the project breaking ground and revised by the contractor's Qualified Stormwater Manager as construction proceeds, to accurately reflect the real-time conditions and practices at the site until final stabilization is reached. This SWMP meets the minimum requirements to comply with the State of Colorado CDPS General Permit for Stormwater Discharges Associated with Construction Activity, COR-090011; Individual Certification COR-\_\_\_\_\_.

**Basic Acronyms / Definitions:**

**GEC Plan:** Grading and Erosion Control Plan (SWMP Site Map)

**CCM:** Control measures, or

**BMP:** Best management practice. These terms are used interchangeably.

**MS4:** Municipal Separate Storm Sewer System

**CDPS:** Colorado Discharge Permit System

**CWA:** Concrete washout area

**SCL:** Erosion log or sediment control log. These terms are used interchangeably

**SF:** Silt fence

**RS:** Rock sock or aggregate bag. These terms used interchangeably.

**IP:** Inlet protection

**DD:** Diversion ditch or diversion berm

**TSD:** Temporary slope drain

**SB:** Straw bale or erosion bale. These terms used interchangeably

**RC:** Rock check dam

**ECB:** Erosion control blanket or rolled erosion control product. These terms are used interchangeably

# SECTION 1: SITE EVALUATION, ASSESSMENT, AND PLANNING

## 1.1 Project/Site Information

**Project/Site Name:** Falcon Highlands South

**Project Location:** Antelope Meadows Circle and Bridal Vail Way Colorado Springs, CO

**County:** El Paso

**State:** CO **ZIP Code:** 80831

**Subdivision/Project:** Falcon Highlands South

**Legal Description:** FALCON HIGHLANDS SOUTH, A PORTION OF SECTION 12, TOWNSHIP 13 SOUTH, RANGE 65 WEST OF THE SIXTH PRINCIPAL MERIDIAN, COUNTY OF EL PASO, STATE OF COLORADO

**Coverage:** State of Colorado CDPS General Permit Stormwater Discharges Associated with Construction Activity, Permit Number 090011; Individual Certification COR-\_\_\_\_\_.

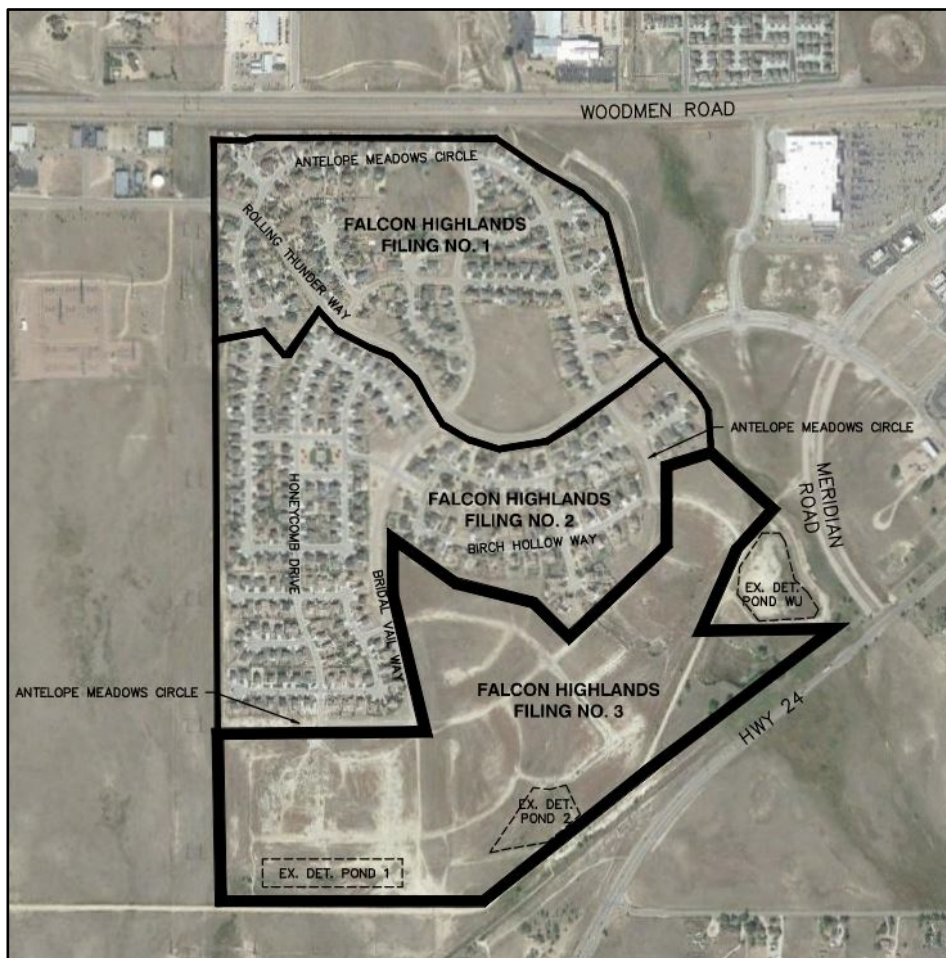

Figure 1: Falcon Highlands vicinity map displaying the three filings.

## 1.2 Contact Information/Responsible Parties

### Owner and Permittee:

Challenger Homes

Jim Byers

8605 Explorer Drive Ste. 250 Colorado Springs, Colorado 80920

**Office #:** (719) 598-5192 **Cell #:** (719) 440-0592 **Email:** jim@challengerhomes.com  
ext. 1006

### Operator:

TBD

TBD

TBD

**Office #:** TBD

**Cell #:** TBD

**Email:** TBD

### Site Superintendent:

Name: George Hart

Title: Site Superintendent

Address: 8605 Explorer Drive Ste. 250 Colorado Springs, CO 80920

Office #: 719.598.5192

Cell #: 970.567.0199

Email: [GHart@challengerhomes.com](mailto:GHart@challengerhomes.com)

**Qualified Stormwater Manager:** Individual responsible for implementing, maintaining, and revising the SWMP, knowledgeable in the principles and practices of ESC and pollution prevention, with the skills and authority to:

- Assess conditions at construction sites that could impact stormwater quality,
- Assess the effectiveness of stormwater controls, and
- Perform inspections

The Qualified Stormwater Manager will be sufficiently qualified for the required duties per the ECM Appendix I.5.2.A.

**Primary Stormwater manager:**

Name: George Hart

Title: Site Superintendent

Address: 8605 Explorer Drive Ste. 250 Colorado Springs, CO 80920

Office #: 719.598.5192

Cell #: 970.567.0199

Email: [GHart@challengerhomes.com](mailto:GHart@challengerhomes.com)

**Alternate Stormwater manager:**

Name: Erin Ganaway

Title: Community Development Project Manager

Address: 8605 Explorer Drive Ste. 250 Colorado Springs, CO 80920

Office #: 719.323.5230

Cell #: 719.323.5230

Email:  
[EGanaway@challengerhomes.com](mailto:EGanaway@challengerhomes.com)

**SWMP prepared by:**

Atwell, LLC.

Richard D. Lyon, PE; Project Manager

12295 Oracle Blvd., Ste. 200

Colorado Springs, Colorado 80921

Office #: (303) 462-1100

Cell #: (414) 534-6011

Email: [RLyon@atwell-group.com](mailto:RLyon@atwell-group.com)

# 1.3 Nature and Sequence of Construction Activity

## Project scope of work:

The scope of work for the residential subdivision of Falcon Highlands South located in Colorado Springs, within El Paso County jurisdiction, consists of the construction of 378 single-family residential lots within the 125.5 acre filing. The subdivision filing includes approximately 2.75 miles of paved right-of-way improvements and 12.2 acres of open space interior to the filing including tracts and dedicated park areas.

The sequence of construction activity in general terms is to consist of initial control measure installation, roadway construction, pond reconstruction activity including earthwork, flatwork, and storm drain reconstruction, sidewalk installations fine grading, and final stabilization with landscaping of streetscapes. Foundation excavation and vertical construction for manufactured homes will follow completion of the Subdivision Improvement Agreement items. Section 3 of this report provides a more detailed account of the anticipated construction filings and sequencing.

The image below shows the subdivision in its four filings.

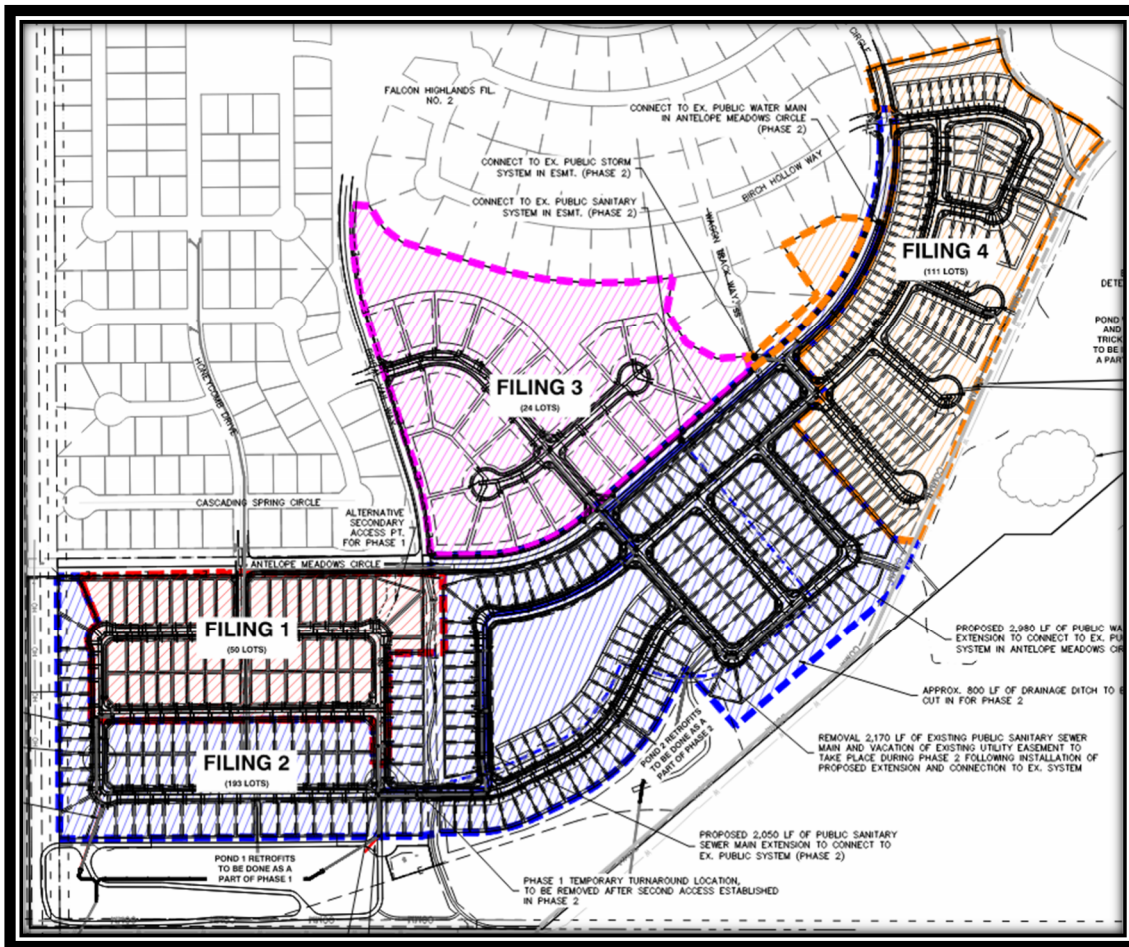

Figure 2: Falcon Highlands South proposed phasing.



**Type of construction activity:**

- Residential     
  Commercial     
  Industrial     
  Road Construction  
 Linear Utility     
  Other (please specify):

Estimated Project Start Date: January 1, 2023  
 Estimated Project Completion Date: October 1, 2023  
 Estimated Project Final Stabilization: October 1, 2023

**Major filings of Construction:**

- Initial CM                     
  Demolition                     
  Grading  
 Utility Installation             
  Interim CM                     
  Road Construction  
 Vertical Construction             
  Final Grade                     
  Final Stabilization CCM  
 Other:

**Earth Work Summary:**

ADJUSTED FILL FACTOR =										15	%
SITE	DISTURBED CUT AREA (SF)	DISTURBED FILL AREA (SF)	DISTURBED TOTAL AREA (SF)	STRIPPING DEPTH (FEET)	STRIPPING STOCKPILE (CY)	CUT (CY)	FILL (CY)	ADJUSTED FILL (CY)	TOTAL		
FULL	2,165,894	2,136,831	4,302,725	0.5	79,680	144,732	120,749	138,861	5,871	LONG	

The cut / fill operations for the development are for overlot grading of the subdivision by filing. There are a total of four filings anticipated for the subdivision and the first two filings are to be pursued in the near future in order to meet the water demand of the existing water taps available and the future water taps available once the future well is installed by the Falcon Highlands Metro District. The last two filings are considered “future filings pending water tap availability”. The earthwork summary in this SWMP is for the entire subdivision. It is anticipated that overlot grading will occur one Filing at a time as Construction Documents are approved, with the most immediate areas of the Filing being Filing 1, Filing 2, and existing Pond 1 and existing Pond 2.

EARTHWORK SUMMARY TABLE											
ADJUSTED FILL FACTOR =										15	%
SITE	DISTURBED CUT AREA (SF)	DISTURBED FILL AREA (SF)	DISTURBED TOTAL AREA (SF)	STRIPPING DEPTH (FEET)	STRIPPING STOCKPILE (CY)	CUT (CY)	FILL (CY)	ADJUSTED FILL (CY)	TOTAL		
FILINGS1 & 2	911,252	1,523,873	2,435,125	0.5	45,095	50,954	88,658	101,957	-51,003	SHORT	

Any excess spoils generated during back fill and compaction of the trench will be spread evenly on site or removed and exported to a permitted facility or operation. If export is necessary, information and permitting information on the export deposition site will be included in this SWMP document. It is anticipated that there will be a net fill for the entirety of the project's earthwork.

## 1.4 Construction Site Estimates

**Total Site Area:** The work area site is estimated to be approximately 115 acres (out of the total Filing area of 125.5 acres) based on Site construction for the rights-of-way, residential lots, tracts, and pond areas. In addition to the work area, there may be a local offsite laydown or "show up" yard as described below.

**Area to be disturbed:** The area to be disturbed is the majority of the 284 acre subdivision for rights-of-way development of roadways and linear utilities, landscaping, and public sidewalk, open space areas, and the residential lots that vary in size from lots of less than one-eighth acre to quarter-acre lots. There are existing Ponds 1, 2, and WU. It is anticipated that retrofits and earthwork of existing detention facility infrastructure within existing Ponds 1 and 2 and minor retrofits to Pond WU.

**Laydown Yard:** Staging areas, or laydown yards, are larger areas used for the temporary storage of equipment and materials and as a centralized location for site workers to report for duty and park personal vehicles during the workday. The use of a construction trailer is likely, as may be the storage of fuel and other hydrocarbons. The use and location of a laydown yard is anticipated to be within the area of the north central future Filing location for construction of Filings 1 and 2 and the eastern future Filing. If relocated from the initially designated location, the SWMP Administrator will add a map to the SWMP documents showing its extents along with any potential pollutants as well as mitigating control measures.

Are there any control measures (CCMs) located outside of the permitted area, that are utilized by the Permittee's construction site for compliance with this permit, but not under the direct control of the Permittee?:  Yes /  No

## 1.5 Soils, Drainage Patterns, and Vegetation

**Soil type:** The Site is made up of loamy sands. Combined bulk samples of the material classified as SP-SM, poorly graded sand with silt according to the Unified Classification System. The on-site soils are specified as Blakeland-Fluvaquentic Haplaquolls for the majority of the site and Blakeland loamy sand within the existing pond areas. Both are categorized as Hydrological Soil Group A as mapped by the Soil Conservation Service (SCS).

**Soil's erosion potential:** The predominant hydrologic soil group is classified as Type "A", which indicates good drainage / infiltration characteristics and high erosive potential. As with any soil exposed to disturbance and stormwater runoff, sediment migration is always a possibility, and

control measures will be employed to mitigate against the potential of sediment leaving the construction work areas including silt fence (SF).

**Predominant drainage pattern:** The Site generally slopes from northeast to southwest and toward the existing detention Ponds 1 and 2. The northeast portion of the Site drains due southeast toward existing detention Pond WU.

**Existing Vegetation:** The Site consists of native weeds and grasses. The percent groundcover of vegetation is approximately 97 percent with full 'vegetative groundcover' and some spare open dirt areas where previous overlot grading and utility installations took place. There is no formal landscaping throughout the subdivision filing. The method used to determine ground cover included visuals during field visits and aerial photography inspection.

## 1.6 Anticipated Sources of Authorized Non-stormwater Discharge

Description and location of any anticipated allowable sources of non-stormwater discharge at the site. Check if applicable:

- Natural springs, only if:
  - Uncontaminated, and
  - Spring flows are not exposed to land disturbance
- Landscape irrigation return flow
- Emergency fire fighting
- Concrete washout (CWA), only if:
  - Liquids from washing concrete tools and concrete mixer chutes are properly contained, and
  - No CWA water leaves the site as surface runoff or reaches receiving watersLiner under CWA is required if:
  - The groundwater table level is high.
  - CWA is within 400 feet of any natural drainage pathway or waterbody, or
  - CWA is within 1,000 feet of any wells or drinking water sources.
- Check if the CWA liner is needed for this site.

**Description of any other anticipated allowable sources of non-stormwater discharge at the site:** While all the above sources are possible on any project, they are not anticipated. If encountered, they will be noted on the SWMP maps and appropriate control measures implemented.

## 1.7 Receiving Waters

**Name and description of watershed:** The Site falls within both the Sand Creek drainage basin and the Falcon Drainage Basin. The immediate receiving waters is Sand Creek which ultimately drains to Fountain Creek.

**Distance from the project to the closest receiving water:** The Site is located approximately 400 feet west of the Site, located within the Banning Lewis Ranch property.

**Is the stream segment impaired?**  Yes /  No

According to the Colorado Dept. of Health and Public Environment website, Sand Creek and its tributaries are listed on Colorado’s Section 303(d) list of impaired waters. The segment description relevant for this Site (COARFO04) is “all tribs to Fountain Creek, which are not on National Forest or Air Force Academy Land” and the impairment listed is “Se” for Selenium.

**Description of all stream crossings located within the construction site boundary:** There are no stream crossings location within the construction site boundary. Any related control measures to mitigate against the release of pollutants to State waters not specifically mentioned in this SWMP will be added by the Stormwater Administrator and necessary details included.

## 1.8 Protected Site Features and Sensitive Areas

**Describe unique site feature or sensitive area to be preserved during construction:** There are no known unique site features or sensitive areas to be preserved during construction. The Site is within and adjacent to residential subdivisions and any unique site features or sensitive areas should have been identified by the Master Development Drainage Plan Report for the subdivision; none were identified. Erosion and sediment control measures are to be implemented for reconstruction of the detention pond in order to mitigate sediment runoff to the adjacent shallow drainageway.

**Describe any known soil or groundwater contamination:** None expected

**Describe management plan for contaminated soils and/or groundwater:** Preliminary geotechnical investigations identified relatively shallow groundwater elevations in the boring logs. There are no known contaminations or contamination sources. The groundwater is to be mitigated for construction with dewatering and it to be permanently mitigated for residential construction by way of subsurface drains for proposed structures.

**Attach applicable Permits (check if applicable):**

- 404 Permit
- 401 Permit
- Dewatering Permit
- Remediation Permit
- Other:

## 1.9 Potential Sources of Pollution

Potential Pollution Source	Potential on this site?	Construction Control Measures (CCM)	CCM Implementation (as needed)
<b>Disturbed &amp; Stored Soils</b> - grading - spoils - stockpiles	YES	Perimeter Controls Preservation of existing vegetation Minimizing disturbed area Materials management Solid waste management Stockpile management Vehicle tracking controls Construction sequencing	1. Delineate protected areas prior to construction. 2. Install CCMs prior to construction. 3. Backfill and surface roughen disturbed areas daily 4. Implement spill response. 5. Implement stockpile mgnt controls. 6. Delineate vehicle travel areas prior to construction, adjust as needed.
<b>Vehicle Tracking</b> - all permitted vehicle traffic	YES	Vehicle tracking controls Street sweeping Minimize access points Avoid work in wet weather	1. Install CCMs prior construction. 2. Delineate vehicle travel areas prior to construction, adjust as needed. 3. Install VTC prior to construction. 4. Implement street sweeping as needed, in conjunction with start of construction
<b>Contaminated Soils</b>	NO	Hazardous materials management Spill response & notification Stockpile management	1. Implement hazardous materials management. 2. Implement spill response procedures. 3. Implement stockpile mgmt controls.
<b>Loading &amp; Unloading</b> - construction materials	YES	Material management Vehicle traffic controls Good housekeeping	1. Manage materials effectively once they arrive on site. 2. Delineate vehicle travel areas prior to construction, adjust as needed. 3. Centralized delivery area (laydown yard, etc.)
<b>Vehicle/equipment maint. &amp; fueling</b> - gas, oil, - diesel - lubricants - hydraulic fluids	YES	Spill prevention controls Designated fuel storage area Spill response & notification Offsite refueling and maint.	1. Designate fuel storage area. 2. Implement spill prevention controls. 3. Implement spill response and notification procedures. 4. Refuel and maintain vehicles and equipment offsite
<b>Outdoor storage</b> - building materials - fertilizers - chemicals	NO	Material storage procedures	1. Designate material storage areas prior to delivery. 2. Materials left outdoors must be covered if they can pollute stormwater. 3. Secondary containment must be used for hazardous materials.
<b>Dust</b> - wind transport - saw cutting	YES	Dust control Temporary soil stabilization Street sweeping	1. Delineate protected areas prior to construction. 2. Implement dust control in conjunction with soil disturbing activities.

		Preservation of existing vegetation Application of dust palliatives	3. Implement temporary soil stabilization measures as soon as practical. 4. Implement street sweeping at the start of major construction and repeat daily as needed.
Routine Maint. Activities (n/i Vehicles and Equip.) - fertilizers - pesticides - detergents - solvents - fuels, oils, etc.	NO	Material storage Hazardous waste management ESC CCMs	1. Designate materials storage areas prior to site arrival. 2. Practice hazardous waste management procedures during the storage of such materials. 3. Install ESC measures prior to landscape work.
Non-industrial Waste - worker trash - portable toilets	YES	Sanitary waste Solid waste management	1. Place temporary sanitary facilities on site. Install perimeter control and prevent off-site discharges. 2. Place trash receptacles (dumpsters) on site. 3. Maintain regularly using a licensed vendor 4. Portable toilets will be located a minimum of 10 feet from stormwater inlets and 50 feet from state waters. 5. Portable toilets are to be secured at all four corners to prevent overturning. 6. Portable toilets are to be cleaned on a weekly basis and inspected daily for spills.
On-site Industrial Waste - construction debris, etc	YES	Waste management Liquid waste management Hazardous waste management	1. Place trash receptacles (dumpsters) on site. 2. Place designated watertight receptacles or washout area(s) prior to activities that produce liquid waste. 3. Implement hazardous waste management procedures. 4. Maintain regularly using a licensed vendor
Concrete Truck Chute/Tool Washing	YES	CWA	1. Install central designated CWA(s), or 2. Deploy mobile washout units, and 3. Maintain regularly
Drywall Mud and Paint	YES	Liquid waste management	Place designated watertight receptacles or washout area(s) prior to activities that produce liquid waste.
Fly Ash - concrete - flow fill	YES	CWA Hazardous waste management	1. Install central designated CWA, or 2. Deploy mobile washout units 3. Implement hazardous waste management procedures.
Dedicated: - asphalt plants - concrete batch plants	NO	Secondary containment CWA Solid waste management	1. Install secondary containment CCMs prior to using dedicated batch plants.

- masonry mixing stations		Materials management	2. Establish dedicated washout area before construction begins. 3. Place trash receptacles on site. 4. Manage materials effectively once they arrive on site.
Waste from: - geo-tech test - potholing - saw cutting - utility borings for locates	YES	Dust control Material storage Solid waste management	1. Implement dust control in conjunction with soil disturbing activities. 2. Designate materials storage areas prior to their arrival on site. 3. Place trash receptacles on site.
Demolition of infrastructure: - concrete curb - asphalt road - steel/rebar	YES	Dust control Solid waste management	1. Implement dust control in conjunction with soil disturbing activities. 2. Place trash receptacles.
Electric Generator - pump	NO	Secondary containment Spill response & notification (GH) Hazardous waste management (GH, CT)	1. Install secondary containment CCMs prior to using generators. 2. Implement hazardous waste management procedures.
Areas where <u>potential spills</u> can occur	NO	Hazardous waste management (GH) Spill response & notification (GH)	1. Implement hazardous waste management. 2. Implement spill response and notification procedures.

**Potential hazardous material & chemical pollutants to stormwater:**

Potentially on Site?	Material/ Chemical	Physical Description	Stormwater Pollutants	Location
YES	Fertilizer	Liquid or solid grains	Nitrogen, phosphorous	Newly seeded areas
NO	Cleaning solvents	Colorless, blue, or yellow-green liquid	Perchloroethylene, methylene chloride, trichloroethylene, petroleum distillates	Staging areas
YES	Asphalt	Black solid	Oil, petroleum distillates	Streets
YES	Concrete and Grout	White solid/grey liquid	Limestone, sand, pH, chromium	Curb and gutter, sidewalk, building construction
YES	Curing compounds	Creamy white liquid	Naphtha	Curb and gutter, sidewalk, driveways, concrete slabs
YES	Hydraulic oil/ fluids	Brown, oily petroleum hydrocarbon	Mineral oil	Leaks or broken hoses from equipment

YES	Gasoline	Colorless, pale brown or pink petroleum hydrocarbon	Benzene, ethyl benzene, toluene, xylene, MTBE	Secondary containment/staging area
YES	Antifreeze/ coolant	Clear green/yellow liquid	Ethylene glycol, propylene glycol, heavy metals (copper, lead, zinc)	Leaks or broken hoses from equipment or vehicles
YES	Sanitary toilets	Various colored liquids	Deodorizing chemicals, bacteria, parasites, and viruses	Staging areas

## SECTION 2: EROSION & SEDIMENT CONTROL



# MEASURES

## 2.1 Sediment Control Measures

Silt Fence (SF)	
<input type="checkbox"/> <i>Permanent</i> <span style="margin-left: 150px;"><input checked="" type="checkbox"/> <i>Temporary</i></span>	
<b>What: Description</b>	SF is a woven geotextile fabric attached to wooden posts and trenched into the ground. It is used to intercept sheet flow runoff from disturbed areas. It is also used as an access control in-lieu of construction fence.
<b>When: Installation</b>	SF shall be installed prior to land disturbing activities. SF shall be removed when the upstream area is stabilized.
<b>Where: Location</b>	SF shall be installed at the locations identified on the SWMP. SF is typically installed along the contour of slopes, which is down slope of a disturbed area which accepts sheet flow, and placed along the perimeter of a construction site. <b><i>SF is not designed to receive concentrated flow, or to be used a filter fabric.</i></b>
<b>How: Maintenance &amp; Inspection</b>	SF shall be installed per detail. Inspect regularly and maintain SF throughout construction. Any section of SF that has a tear, hole, slumping, undercutting or has been bypassed shall be replaced. Accumulated sediment shall be removed before it reaches a depth of ½ the height of the silt fence, usually 6 inches.

Inlet Protection (IP)	
<input type="checkbox"/> <i>Permanent</i> <span style="margin-left: 150px;"><input checked="" type="checkbox"/> <i>Temporary</i></span>	
<b>What: Description</b>	IP is a permeable barrier that is installed around an inlet drain to filter runoff and remove sediment before entering the storm system. IP can be constructed of: RS, SCL, SF, or other materials.
<b>When: Installation</b>	Install IP for existing catch basins prior to land disturbing activities upslope from the inlet. IP for proposed catch basins shall be installed immediately after the drain is constructed. IP and associated sediment must be removed and properly disposed of when the drainage area upstream is stabilized.
<b>Where: Location</b>	Install IP at the locations identified on the SWMP. IP is not a stand-alone measure. It shall be used in conjunction with other up gradient measures.
<b>How: Maintenance &amp; Inspection</b>	Install IP per detail. IP shall enable the drain to function without completely blocking the flow. Inspect regularly and maintain IP throughout construction as it is the final measure before runoff enters the storm drain. Accumulated sediment shall be removed when it has reached ½ of the height of the IP or loses functionality, whichever comes first. IP is not standalone measure and shall be part of a redundant system.

<b>Rock Sock (RS)</b>	
<input type="checkbox"/> <i>Permanent</i> <span style="margin-left: 150px;"><input checked="" type="checkbox"/> <i>Temporary</i></span>	
<b>What: Description</b>	RS is an elongated cylindrical filter constructed of gravel wrapped by wire mesh or woven geotextile (aka “curb socks” if placed at angles at curb line).
<b>When: Installation</b>	Install RS prior to land disturbing activities; once upstream stabilization is complete. Accumulated sediment shall be removed and properly disposed of.
<b>Where: Location</b>	RS shall be installed at the locations identified on the EC Plan. They are use for perimeter control of a disturbed area, or as part of IP.
<b>How: Maintenance &amp; Inspection</b>	Install RS per details. Inspect regularly and maintain RS as they are susceptible to displacement and breakage due to vehicle traffic. Accumulated sediment shall be removed to maintain functionality.

## 2.2 Erosion Control Measures

<b>Surface Roughening (SR)</b>	
<input type="checkbox"/> <i>Permanent</i> <span style="margin-left: 150px;"><input checked="" type="checkbox"/> <i>Temporary</i></span>	
<b>What: Description</b>	SR is tracking, scarifying, imprinting or tilling a disturbed area to provide temporary stabilization. Variations in the soil are created to help minimize wind and water erosion.
<b>When: Installation</b>	SR shall be performed either after final grading or to temporarily stabilize an area during active construction.
<b>Where: Location</b>	SR shall be used in the locations identified on the SWMP. It can be used on mild and steep slopes.
<b>How: Maintenance &amp; Inspection</b>	SR shall be installed per detail. SR shall always be perpendicular to the slope. Continuously inspect and maintain all surfaces that are roughened throughout construction. SR shall be inspected for erosion as it is only a temporary control. Vehicles and equipment shall not be driven over areas that have been surface roughening. Refresh SR as needed.

<b>Temporary and Permanent Seeding (TS/PS)</b>	
<input checked="" type="checkbox"/> <i>Permanent</i> <span style="margin-left: 150px;"><input checked="" type="checkbox"/> <i>Temporary</i></span>	
<b>What: Description</b>	Seed is applied to disturbed areas in an effort to establish vegetation. TS is used to stabilize disturbed areas that will be inactive for an extended period. PM is used to stabilize areas at final grade that will not be otherwise stabilized. Effective seeding includes preparation of a seedbed, selection of an

	appropriate seed mixture, proper planting techniques, and protection of the seeded area with mulch, geotextile, or other appropriate measures. Mulching helps to protect the bare soil and must be secured by crimping, tackifiers, netting or other measures.
<b>When: Installation</b>	TS/PS shall be performed on temporary inactive surfaces and following the completion of final grading.
<b>Where: Location</b>	TS/PS shall be completed in the locations identified on the SWMP to stabilize areas at final grade that will not otherwise be stabilized.
<b>How: Maintenance &amp; Inspection</b>	TS/PS and secured mulching shall be installed per seed mix specifications and details. Continuously inspect and maintain TS/PS and secured mulch throughout construction. Prepare the seedbed, select an appropriate seed mixture, use proper planting techniques and protect the seeded area with secured mulch.

### Mulching (MU)

**Permanent**

**Temporary**

<b>What: Description</b>	MU consists of evenly applying straw, hay, shredded wood mulch, bark or compost to disturbed soils and securing the mulch by crimping, tackifiers or netting.
<b>When: Installation</b>	MU is used in conjunction with TS/PS to help protect the seed bed and stabilize the soil. Mulch can also be used as a temporary cover on low to mild slopes to help temporarily stabilize disturbed area where there are growing season constraints. After MU application, there shall not be bare ground surface exposed. Reapply mulch, as needed, to cover bare areas.
<b>Where: Location</b>	Temporary and/or permanent MU shall be completed in the locations identified on the SWMP.
<b>How: Maintenance &amp; Inspection</b>	MU shall be installed per detail. After MU, the bare ground surface shall not be more than 10% exposed. Re-apply mulch, as needed, to cover bare areas.

## 2.3 Materials Management Control Measures

### Concrete Washout Areas (CWA)

**Permanent**

**Temporary**

<b>What: Description</b>	A CWA is a specific area of the construction site designated and managed for concrete washing activities. Options available: excavation of a pit in the ground, use of an above ground storage area or use of prefabricated haul-away CWA containers.
<b>When: Installation</b>	CWA shall be installed prior to any concrete delivery to the construction site; and remove upon termination of use of the washout. Accumulated solid waste, including concrete waste and any contamination soils, must be removed from the site to a designated disposal location.
<b>Where: Location</b>	CWA shall be installed at the locations identified on the SWMP. If the groundwater table is high; or if the CWA will be placed within 400 ft of a natural drainage pathway/waterbody; or within 1,000 ft of a wells or drinking water source it must be lined.
<b>How: Maintenance &amp; Inspection</b>	CWA shall be installed per detail. Inspect regularly and maintain CWA throughout construction. Ensure adequate signage is in place identifying the location of the CWA. Remove concrete waste when filled to about $\frac{2}{3}$ of CWA capacity to maintain functionality.

### Stockpile Management (SP)

**Permanent**

**Temporary**

<b>What: Description</b>	SP includes measures to minimize erosion and sediment transport from stockpiles. SP shall be used when soils or other erodible materials are stored at a construction site.
<b>When: Installation</b>	SP locations shall be determined during construction. If temporary removal of a CCM is necessary to access the SP, ensure CCMs area re-installed per detail drawing. When SP is no longer needed, properly dispose of excess materials and re-vegetate or stabilize the ground surface where the SP was located.
<b>Where: Location</b>	SP locations shall be placed away from areas where concentrated stormwater flow is anticipated, major drainage ways, gutters, and storm sewer inlets. SP locations shall be noted on the SWMP.
<b>How: Maintenance &amp; Inspection</b>	SP shall be installed per details. Inspect regularly and maintain SP throughout construction. It is recommended to place SP on a pervious surface and protected from sediment transport with measures such as SCL, VB and/or SF. SP are only allowed on impervious surfaces if no other practical alternative exists. Provide weighted sediment control measures around the perimeter of the SP, such as RS or sand bags.

### Street Sweeping (SS)

**Permanent**

**Temporary**

<b>What: Description</b>	SS is used where vehicles track sediment onto paved roadways to reduce the transport of it into storm drain systems or surface waterways.
------------------------------	---

<b>When: Installation</b>	Manual SS or mechanical vacuuming SS shall be conducted when there is noticeable sediment accumulation on roadways adjacent to the construction site. SS shall be completed prior to any precipitation events, at the end of the workday as needed, and at the end of construction.
<b>Where: Location</b>	SS shall be utilized throughout the site and also on adjacent areas to construction.
<b>How: Maintenance &amp; Inspection</b>	Use standard SS equipment to adequately remove sediment from roadways adjacent to the construction site. If conditions are wet, accumulated mud and sediment may need to be manually scraped from adjacent roadway surfaces.

## 2.4 Site Management Control Measures

### Limits of Construction (LOC)

<input type="checkbox"/> <i>Permanent</i> <span style="margin-left: 150px;"><input checked="" type="checkbox"/> <i>Temporary</i></span>	
<b>What: Description</b>	LOC is used to designate the area of land that will be disturbed by construction activities.
<b>When: Installation</b>	The permitted LOC shall be designated prior to land disturbing activities. If land is disturbed <u>outside</u> of the limits, then the State and any local stormwater construction discharge permits and SWMP Plan must be amended.
<b>Where: Location</b>	The permitted LOC shall be identified on the SWMP Plan.
<b>How: Maintenance &amp; Inspection</b>	LOC are typically delineated by silt fence or construction fence. Inspect LOC continuously and maintain the permitted LOC in an effort to not disturb land outside of the boundaries.

### Vehicle Tracking Control (VTC)

<input type="checkbox"/> <i>Permanent</i> <span style="margin-left: 150px;"><input checked="" type="checkbox"/> <i>Temporary</i></span>	
<b>What: Description</b>	VTC is a stabilized site access point that helps remove sediment from vehicle tires and reduces tracking of sediment onto paved surfaces.
<b>When: Installation</b>	Install VTC prior to any land disturbing activities; and removed when there is no longer the potential for vehicle tracking to occur.
<b>Where: Location</b>	VTC shall be installed at the location identified on the SWMP. Locate VTC where frequent vehicle traffic will exit the construction site onto a paved roadway.
<b>How: Maintenance &amp; Inspection</b>	VTC shall be installed per detail. All VTC must have non-woven geotextile fabric between the soil and rock pad. <u>Recycled concrete aggregate is not allowed because concrete dust elevates pH in stormwater.</u> Inspect regularly and maintain VTCs throughout construction. If the area becomes clogged with sediment, remove and dispose of excess sediment or replace material with a

	fresh layer of rock. Any sediment that is tracked onto adjacent roadways shall be cleaned with brooms, shovels (no water washing), or mechanically cleaned with a street vacuum sweeper.
--	--

---

**Stabilized Staging Area (SSA)**

---

*Permanent*                       *Temporary*

<b>What: Description</b>	LY is a clearly designated area where construction equipment and vehicles, stockpiles, waste bins and other construction-related materials are stored. If the construction site is big, more than one LY may be necessary.
<b>When: Installation</b>	LY shall receive perimeter controls as necessary before placed in use. Storage of pollutants may need additional CCMs.
<b>Where: Location</b>	LY location shall be noted on the SWMP and included in the regular inspection scope along with the rest of the project.
<b>How: Maintenance &amp; Inspection</b>	LY shall be inspected regularly and maintained throughout construction. A clean area shall be maintained as well as repairing any perimeter controls and following good housekeeping practices.

## 2.5 Structural Control Measures

The development of Falcon Highlands South includes the following structural control measures:

- Extended Detention Basins
- Grass Swale

The subdivision utilizes three existing extended detention basin ponds for water quality and full spectrum detention. The on-site ponds are Pond 1 (southwest) and Pond 2 (south). Pond WU to the northeast is off-site but treats a relatively small tributary area of the subdivision. Detention ponds are structural control measures as they are permanent BMPs that are designed with target volume thresholds and include infrastructure including an outlet structure with orifice plate(s), micropool, concrete trickle channels, and forebays. This infrastructure stabilizes and controls runoff and flow patterns, and release rates.

There is a proposed grasslined swale that extends from future Filing 4 to Pond 2 along the south property boundary of the subdivision. This is a structural control measure that requires a swale dimension as engineered in design plans to accommodate the major storm event and one foot of freeboard.

There are no other known structural control measures associated with this development.

# SECTION 3: CONSTRUCTION SITE PHASING & ESC PLAN

## 3.1 Construction Site Phasing Summary

**Project Approach:** The proposed Falcon Highlands South subdivision construction is to be performed per the Construction Drawings as approved by El Paso County.

Construction Phasing is to be take place in two sequential filings followed by the remaining two filings that are considered “future filings pending additional water supply”.

Filing 1 consists of the northern portion of the southwest residential blocks south of Antelope Meadows Circle and Falcon Highlands Filing No. 2. Filing 1 includes the extension of Honeycomb Drive and 50 residential lots with associated right-of-way improvements for roadways and linear utilities, tree lawns, and public sidewalks. The water main installation is to extend off of Antelope Meadows Circle and loop into itself in order to serve 50 single-family residential lots. The public storm sewer system within Filing 1 and future Filing 2 is to be installed as a part of Filing 1 to outlet storm pipes into existing Pond 1. Any retrofits or earthwork within existing Pond 1 is to take place during Filing 1. The sanitary main through Filing 1 and part of Filing 2 that extends to the existing lift station is to remain in service and undisturbed.

Filing 2 is south and east of Filing 1 and builds out an additional 193 lots for a total of 246 lots between Filing 1 and 2. This lot total is the anticipated water supply for the new well to be owned and maintained by the Woodmen Hills Metropolitan District. The public storm sewer systems that outfall to existing Pond 1 is existing at the time of Filing 2 and the public systems that outfall to existing Pond 2 is to be constructed as a part of Filing 2. A grass-lined swale designed for an outfall to Pond 2 is to be constructed as a part of Filing 2 and the northeast stretch of the swale will collect overland flow from the undeveloped future Filing east of Filing 2. The existing public sanitary sewer that services Filing No. 2 is to remain active and undisturbed until the proposed public sanitary sewer within the new rights-of-way for Filing 2 is constructed and connected to the existing sanitary sewer manhole to reroute the flow to the new system. At that point the existing system through Filing 2 is to be abandoned and removed. The public water main extension is to be looped through the Filing 2 rights-of-way and connect to the existing stub toward the northeast in Antelope Meadows Circle.

Future Filings include the east and north central areas of the filing. Following construction of Filings 1 and 2, water main loops and roadway accesses will be established to follow IFC criteria for fire suppression emergency access. Any storm, water, and sanitary infrastructure to service the remaining future Filing lots are to be installed at the time of construction for their respective filings.

Construction is to be begin with initial control measures installation including perimeter silt fence (SF), vehicle tracking control (VTC), and designation of the stabilized storage area (SSA) within the site. Onsite storm inlets are to be protected via inlet protection (IP) and rock socks (RS) within the

adjacent downstream private roadway is to be installed. Any downstream, offsite storm inlets susceptible to storm water flow from the Site construction area are to be protected via inlet protection.

Following initial control measure installations, construction is to begin with utility installations followed by construction of the concrete curb and gutter and asphalt. Filing 1 includes retrofit construction for stormwater infrastructure in Pond 1 for forebays and the outlet structure with micropool. The contractor will use a tracked excavator with a 24" bucket to dig the trenches for linear utilities. Shoring may be required for the deeper sanitary sewer stretches.

Any stockpile (SP) location on site is anticipated to be temporary but will have erosion and sediment control measures surrounding the designated location as it is anticipated that stockpiles will remain on site for extended periods (weeks) prior to use for fill or feathering of existing site areas.

Any mobile control measures (or BMPs) that need to be used will be deployed at the end of each workday down gradient of disturbed areas until said areas are stabilized. Control measures will also be deployed in the event of rain or other storm event that has the potential to mobilize sediment.

Interim control measures such as a concrete washout area (CWA), adjustments to the SSA and SP locations to accommodate construction vehicles for excavation, foundation crew work, and concrete pours for curb and gutter and sidewalk installations within the rights-of-way as well as foundation construction for the residential homes.

Final stabilization is to be take place after all site rights-of-way and pond construction has been completed such as concrete flatwork, asphalt paving, and storm infrastructure construction. Final stabilization requires that all disturbing activities at the site are complete and vegetative cover with a density of at least 70 percent of the native background vegetative cover for the area is established on all unpaved areas and areas not covered by permanent structures. Noxious weeds are not counted in the 70%. The Site is to be final stabilized according to the final landscaping plans which includes xeriscape rock areas, native grass areas, and assigned shrubs and trees.

After the majority of the vertical construction takes place where little to no site disturbance is required and less construction vehicles and crews are required to be on site, site development is to take place including fine grading within the lots. It is anticipated that the remaining building construction is limited to exterior finishes and interior finished. At this point, rights-of-way construction and detention pond reconstruction are to be completed.

Construction activity is to be closed out upon County inspection for approval of the final stabilized conditions.



## 3.2 General SWMP Notes

1. Stormwater discharges from construction sites shall not cause or threaten to cause pollution, contamination, or degradation of state waters. All work and earth disturbance shall be done in a manner that minimizes pollution of any on-site or off-site waters, including wetlands.
2. Notwithstanding anything depicted in these plans in words or graphic representation, all design and construction related to roads, storm drainage and erosion control shall conform to the standards and requirements of the most recent version of the relevant adopted El Paso county standards, including the land development code, the engineering criteria manual, the drainage criteria manual, and the drainage criteria manual volume 2. Any deviations from regulations and standards must be requested, and approved, in writing.
3. A separate stormwater management plan (swmp) for this project shall be completed and an erosion and stormwater quality control permit (esqcp) issued prior to commencing construction. Management of the swmp during construction is the responsibility of the designated qualified stormwater manager or certified erosion control inspector. The swmp shall be located on-site at all times during construction and shall be kept up to date with work progress and changes in the field.
4. Once the esqcp is approved and a "notice to proceed" has been issued, the contractor may install the initial stage erosion and sediment control measures as indicated on the approved gec. A preconstruction meeting between the contractor, engineer, and El Paso county will be held prior to any construction. It is the responsibility of the applicant to coordinate the meeting time and place with county staff.
5. Control measures must be installed prior to commencement of activities that could contribute pollutants to stormwater. Control measures for all slopes, channels, ditches, and disturbed land areas shall be installed immediately upon completion of the disturbance.
6. All construction control measures shall be maintained until permanent stabilization measures are implemented. Temporary construction control measures must be removed prior to permit closeout.
7. Temporary stabilization shall be implemented on disturbed areas and stockpiles where ground disturbing construction activity has permanently ceased or temporarily ceased for longer than 14 days.
8. Final stabilization must be implemented at all applicable construction sites. Final stabilization is achieved when all ground disturbing activities are complete and all disturbed areas either have a uniform vegetative cover with individual plant density of 70 percent of pre-disturbance levels established or equivalent permanent alternative stabilization method is implemented. All temporary sediment and erosion control measures shall be removed upon final stabilization and before permit closure.
9. All permanent stormwater management facilities shall be installed as designed in the approved plans. Any proposed changes that effect the design or function of permanent stormwater management structures must be approved by the ecm administrator prior to implementation.
10. Earth disturbances shall be conducted in such a manner so as to effectively minimize accelerated soil erosion and resulting sedimentation. All disturbances shall be

- designed, constructed, and completed so that the exposed area of any disturbed land shall be limited to the shortest practical period of time. Pre-existing vegetation shall be protected and maintained within 50 horizontal feet of a waters of the state unless shown to be infeasible and specifically requested and approved.
11. Compaction of soil must be prevented in areas designated for infiltration control measures or where final stabilization will be achieved by the vegetative cover. Areas designated for infiltration control measures shall also be protected from sedimentation during construction until final stabilization is achieved. If compaction prevention is not feasible due to site constraints, all areas designated for infiltration and vegetation control measures must be loosened prior to installation of the control measure(s).
  12. Any temporary or permanent facility designed and constructed for the conveyance of stormwater around, through, or from the earth disturbance area shall be a stabilized conveyance designed to minimize erosion and the discharge of sediment off-site.
  13. Concrete wash water shall be contained and disposed of in accordance with the swmp. No wash water shall be discharged to or allowed to enter state waters, including any surface or subsurface storm drainage system or facilities. Concrete washouts shall not be located in an area where shallow groundwater may be present, or within 50 feet of a surface water body, creek or stream.
  14. During dewatering operations, uncontaminated groundwater may be discharged on-site, but shall not leave the site in the form of surface runoff unless an approved state dewatering permit is in place.
  15. Erosion control blanketing or other protective covering shall be used on slopes steeper than 3:1.
  16. Contractor shall be responsible for the removal of all wastes from the construction site for disposal in accordance with local and state regulatory requirements. No construction debris, tree slash, building material wastes or unused building materials shall be buried, dumped, or discharged at the site.
  17. Waste materials shall not be temporarily placed or stored in the street, alley, or other public way, unless in accordance with an approved traffic control plan. Control measures may be required by El Paso county engineering if deemed necessary, based on specific conditions and circumstances.
  18. Tracking of soils and construction debris off-site shall be minimized. Materials tracked off-site shall be cleaned up and properly disposed of immediately.
  19. The owner/developer shall be responsible for the removal of all construction debris, dirt, trash, rock, sediment, soil, and sand that may accumulate in roads, storm drains and other drainage conveyance systems and stormwater appurtenances as a result of site development.
  20. The quantity of materials stored on the project site shall be limited, as much as practical, to that quantity required to perform the work in an orderly sequence. All materials stored on-site shall be stored in a neat, orderly manner, in their original containers, with original manufacturer's labels.
  21. No chemical(s) having the potential to be released in stormwater are to be stored or used on-site unless permission for the use of such chemical(s) is granted in writing by the ecm administrator. In granting approval for the use of such chemical(s), special conditions and monitoring may be required.

22. Bulk storage of allowed petroleum products or other allowed liquid chemicals in excess of 55 gallons shall require adequate secondary containment protection to contain all spills on-site and to prevent any spilled materials from entering state waters, any surface or subsurface storm drainage system or other facilities.
23. No person shall cause the impediment of stormwater flow in the curb and gutter or ditch except with approved sediment control measures.
24. Owner/developer and their agents shall comply with the "Colorado water quality control act" (title 25, article 8, crs), and the "clean water act" (33 usc 1344), in addition to the requirements of the land development code, dcm volume ii and the ecm appendix i. All appropriate permits must be obtained by the contractor prior to construction (1041, npdes, floodplain, 404, fugitive dust, etc.). In the event of conflicts between these requirements and other laws, rules, or regulations of other federal, state, local, or county agencies, the most restrictive laws, rules, or regulations shall apply.
25. All construction traffic must enter/exit the site only at approved construction access points.
26. Prior to construction the permittee shall verify the location of existing utilities.
27. A water source shall be available on-site during earthwork operations and shall be utilized as required to minimize dust from earthwork equipment and wind.
28. The soils report for this site has been prepared by [company name, date of report] and shall be considered a part of these plans.
29. At least ten (10) days prior to the anticipated start of construction, for projects that will disturb one (1) acre or more, the owner or operator of construction activity shall submit a permit application for stormwater discharge to the Colorado department of public health and environment, water quality division. The application contains certification of completion of a stormwater management plan (swmp), of which this grading and erosion control plan may be a part. For information or application materials contact:

Colorado Department of Public Health and Environment  
Water Quality Control Division  
WQCD-Permits  
4300 Cherry Creek Drive South  
Denver, CO 80246-1530  
Attn: Permits Unit

# SECTION 4: WASTE MANAGEMENT PLAN

## 4.1 Covering Outdoor Storage and Handling Areas

---

### Covering Outdoor Storage and Handling Areas

---

*Permanent*

*Temporary*

**Description:** When raw materials, byproducts, finished products, storage tanks, and other materials are stored or handled outdoors, stormwater runoff that comes in contact with the materials can become contaminated. Proactively covering storage and handling areas can be an effective source control for such areas. Coverings can be permanent or temporary and consist of tarp, plastic sheeting, roofing, enclosed structures, or other approaches that reduce exposure of materials to precipitation and wind.

**Uses:** Covering is appropriate for areas where solids (e.g., gravel, compost, building materials) or liquids (e.g., oil, gas, tar) are stored, prepared, or transferred. Cover the following areas that are applicable to this construction site:

- **Loading and Unloading:** Loading and unloading operations usually take place at outside storage or staging area on the construction site. Materials may be spilled during transfer between storage facilities and trucks during pumping of liquids, pneumatic transfer of dry chemicals, and mechanical transfer of bags, boxes, drums, or other containers by material handling equipment.
- **Aboveground Tanks/Liquid Storage:** Accidental releases of chemicals from above-ground liquid storage can contaminate stormwater with a variety of pollutants. Several common causes of accidental releases from above-ground storage include: external corrosion and structural failure, problems due to improper installation, spills and overfills due to operator error, failure of piping systems, and leaks or spills during pumping of liquids or gases between trucks to a storage facility.
- **Outside Manufacturing:** Common outside manufacturing activities may include parts assembly, rock grinding or crushing, metals painting or coating, grinding or sanding, degreasing, concrete manufacturing, parts cleaning or operations that use hazardous materials. These activities can result in dry deposition of dust, metal and wood shavings and liquid discharges of dripping or leaking fluids from equipment or process and other residuals being washed away in storm runoff. In addition, outside storage of materials and waste products may occur in conjunction with outside manufacturing.
- **Waste Management:** Wastes spilled, leached, or lost from outdoor waste management areas or outside manufacturing activities may accumulate in soils or on other surfaces and be carried away by storm runoff. There is also the potential for liquid wastes from surface impoundments to overflow to surface waters or soak the soil where they can be picked up by runoff. Possible stormwater contaminants include toxic compounds, oil and grease, oxygen-demanding organics, paints and solvents, heavy metals and high levels of suspended solids. Lack of coverage of waste receptacles can result in precipitation seeping through the material and collecting contaminants or the material being blown around the site and into the storm sewer system. Containment sources include waste

piles, wastewater and solid waste treatment and disposal, land application sites, dumpsters, or unlabeled drums.

- **Outside Storage of Materials:** Raw materials, intermediate products, byproducts, process residuals, finished products, containers, and materials storage areas can be sources of pollutants such as metals, oils and grease, sediment and other contaminants. Pollutant transport can occur when solid materials wash off or dissolve into water, or when spills or leaks occur.

**Practice Procedures:**

- Where practical, conduct operations indoors. If outdoors, then select a temporary or permanent covering to reduce exposure of materials to precipitation and runoff.
- The type of covering selected depends on a variety of factors such as the type and size of activity being conducted and materials involved. Types of cover range from relatively inexpensive tarps and plastic sheeting to overhead structures or fully enclosed buildings equipped with ventilation, lighting, etc.
- Covering practices should be combined with Good Housekeeping to be most effective.
- Tarps and plastic sheets require more frequent inspection and maintenance.

**Place site-specific information here:**

---

---

## 4.2 Spill Prevention and Response Plan

---

### Spill Prevention & Response Plan

---

*Permanent*                       *Temporary*

Spills and leaks of solid and liquid materials processed, handled or stored outdoors can be a source of stormwater pollution. Spilled substances can reach receiving waters when runoff washes these materials from impervious surfaces or when spills directly enter the storm system during dry weather conditions. Effective controls depend on spill prevention and response measures, proper training, and may include structural spill containment or control devices. Spill containment measures include temporary or permanent curbs or berms that surround a potential spill site. Berms may be constructed of concrete, earthen material, metal, synthetic liners, or other material. Spill control devices include valves, slide gates, or other devices that can control and contain spilled material.

#### Spill Prevention Measures

- Train key employees in plan and provide clear, common-sense spill prevention practices and clean-up procedures to be strictly followed.
- Identify equipment that is exposed to precipitation, pollutants that may be generated and possible sources of leaks or discharges.
- Perform inspections and preventative maintenance of equipment for proper operation and to check for leaks or evidence of discharge (stains). Ensure repairs are completed or provide temporary leak containment until such repairs can be made.

- Drain used motor oil and other automotive fluids in a designated area away from storm inlets. Collect spent fluids and recycle or dispose of properly. Never dispose into storm or sanitary sewer.
- In fueling areas, clean up spills with dry methods (absorbents) and use damp cloths on gas pumps and damp mops on paved surfaces.
- Never hose down a spill or absorbent materials into the storm drain, or down into an interior floor drain which leads to the sanitary sewer system.
- Reduce stormwater contact with equipment and materials by implementing covered storage, reduce stormwater run-on and follow good housekeeping practices.
- Post signs at critical locations with Spill Prevention and Response Plan information.

**Identification of Spill Areas:** Spill prevention and response measures shall be implemented at construction sites in areas where materials may be spilled in quantities that can adversely impact receiving waters or the storm system. Identify potential spill areas, potential spill volumes, material types, frequency of material used, and drainage paths from spill areas with relation to storm sewer inlets, adjacent water bodies, structural CCMs, and containment structures. Use this information to determine the types of spill prevention and control measures needed specific to the site conditions. Show the potential spill areas on the EC Plan:

- Loading and unloading areas
- Outdoor storage areas
- Outdoor manufacturing or processing activities
- Waste disposal
- Areas that generate significant dust or particulates that may later deposit on the ground
- Areas prone to spills based on past experience at the site
- Locations where other routine maintenance activities occur
- Areas where smaller leaks may occur (parking lots)

**Material Handling Procedures:** From a water quality perspective, the primary principle behind effective material handling practices is to minimize exposure to precipitation. Store the material indoors, otherwise implement the following outdoor materials handling procedures:

- Divert stormwater around materials storage areas.
- Use appropriate perimeter control measures (secondary containment).
- Keep bulk solid materials (raw materials, sand, gravel, topsoil, compost, concrete, packing materials, metal products, etc) covered and protected from stormwater.
- When practical, store materials on impermeable surfaces.
- Store hazardous materials according to federal, state, and local requirements.
- Adopt procedures to reduce spills or leaks during filling or transfer of materials.
- Substitute less toxic or nontoxic materials for toxic materials.
- Store containers that are easily punctured or damaged away from high traffic areas.
- Add waste-capture containers such as collection pans for lubricating fluids.
- Store drums and containers with liquids on impermeable surfaces and provide secondary containment. Place drums stored outdoors on pallets to minimize contact with runoff.

**Spill Response Procedures:** Tailor spill response procedures to site-specific conditions and industry-specific regulatory requirements. Follow procedures:

- Contain and cleanup spills promptly after the spill is discovered.
- Deploy spill kits if available.

- Sweep up small quantities of pollutants to reduce exposure to runoff.
- Place absorbents at fueling areas or areas susceptible to spills.
- Wipe up small spills with a rag, store rags in appropriate containers, dispose of rags properly or use a professional industrial cleaning service.
- Contain medium-sized spills with absorbents and use berms or absorbent "snakes" as temporary booms for the spill. Store and dispose of absorbents properly. Wet/dry vacuums may be used, but not for volatile fluids.
- Install drip pans below minor equipment leaks until a repair can be made.
- For large spills, first contain the spill and plug storm inlet where the liquid may migrate off-site, then clean up the spill.
- Excavation of spill areas to removed contaminated material may be required where large liquid spills occur on unpaved surfaces.
- Maintain an inventory of cleanup materials onsite and strategically locate them based on the types and quantities of chemicals present.
- Records of spills, leaks, or overflows that result in the discharge of pollutants must be documented and maintained.

Two approaches are used when implementing spill containment measures: 1) Design system to contain the entire spill; or 2) Use curbing to route spilled material to a collection basin. Both containment berming and curbing should be sized to safely contain or convey to a collection basin a spill from the largest storage tank, tanker truck, or other containment device in the possible spill area. The spill containment area must have an impermeable surface (impermeable liner, asphalt or concrete) to prevent groundwater contamination. Design containment system to enable collection and removal of spilled material through a pump or vacuum trucks, sorbent or gelling material, etc. Material removed must be disposed of or recycled according to local, state, and federal standards. If the capacity of the spill containment is exceeded, supplemental measures should be available such as a portable containment device, sorbent materials, or gelling agents to solidify the material. Water that collects within containment areas due to rainfall or snowmelt must be appropriately treated before release from the spill area.

**Emergency 24-Hour Site Contact (with spill response and clean-up authority):**

Company/Developer: Challenger Homes

Contact Name: George Hart

Address: 8605 Explorer Drive Ste. 250 Colorado Springs, CO 80920

Office #: 719.598-5192

Cell #: 970.567.0199

Email: GHart@challengerhomes.com

**Alternate Emergency 24-Hour Site Contact:**

Company/Developer: Challenger Homes

Contact Name: Erin Ganaway

Address: 8605 Explorer Drive Ste. 250 Colorado Springs, CO 80920

Office #: 719.323.5230

Cell #: 719.323.5230

Email: EGanaway@challengerhomes.com

**Notification Procedures:** Some spills may need to be reported to the State of Colorado, Water Quality Control Division and Adams County Stormwater Division immediately upon discovery. Releases of chemical, oil, petroleum product, sewage, etc., which may enter State Waters must

be reported to: State of Colorado, 24-hour Emergency Spill Reporting Line: 1-877-518-5608.  
<https://www.colorado.gov/pacific/cdphe/wq-environmental-spills>.  
Tri-County Health Department: 303-220-9200.

## 4.3 Good Housekeeping

---

### *Good Housekeeping Practices*

---

*Permanent*

*Temporary*

**Description:** Good housekeeping practices are designed to maintain a clean and orderly work environment. The most effective first steps towards preventing stormwater pollution at construction sites simply involve using common sense to improve the site's basic housekeeping methods. Poor housekeeping practices result in increased waste and potential for stormwater contamination. A clean and orderly work site reduces the possibility of accidental spills caused by mishandling of chemicals and equipment and should reduce safety hazards to personnel. A well-maintained material and chemical storage area will reduce the possibility of stormwater mixing with pollutants. Some simple procedures a site can use to promote good housekeeping include improved operation and maintenance of machinery and processes, material storage practices, material inventory controls, routine and regular clean-up schedules, maintaining well organized work areas, signage, and educational program for employees and the general public.

**Practice Procedures for Operation and Maintenance:**

- Maintain dry and clean floors and ground surfaces by using brooms, shovels, vacuums or cleaning machines, rather than wet clean-up methods.
- Regularly collect and dispose of garbage and waste material.
- Routinely inspect equipment to ensure that it is functioning properly without leaking and conduct preventative maintenance and needed repairs.
- Train employees on proper clean up and spill response procedures.
- Designate separate areas for auto parking, vehicle refueling and routine maintenance.
- Promptly clean up leaks, drips and other spills.
- Cover and maintain dumpsters and waste receptacles. Add additional dumpsters or increase frequency of waste collection if overflowing conditions reoccur.
- For outdoor painting and sanding: Conduct activities in designated areas that provide adequate protection to prevent overspray and uncontrolled emissions. All operations should be conducted on paved surfaces to facilitate cleanup. Use portable containment as necessary for outside operations. Clean up and properly dispose of excess paint, paint chips, protective coatings, grit waste, etc.
- Maintain vegetation on facility grounds in a manner that minimizes erosion. Follow the Landscape Maintenance and Pesticide, Herbicide and Fertilizer Usage CCMs to ensure that minimum amounts of chemicals needed for healthy vegetation are applied to minimize transport of these materials in runoff.

**Practice Procedures for Material Storage Practices:**

- Provide adequate aisle space to facilitate material transfer and access for inspection.
- Store containers, drums, and bags away from direct traffic routes to reduce container damage resulting in accidental spills.
- Use additional perimeter control measures (secondary containment)



- Stack containers according to manufacturer's instructions to avoid damaging the containers from improper weight distribution. Also store materials in accordance with directions in Material Safety Data Sheets (MSDSs).
- Store containers on pallets or similar devices to prevent corrosion of containers that results from containers coming in contact with moisture on the ground.
- Store toxic or hazardous liquids within curbed areas or secondary containers.

**Practice Procedures for Material Inventory Practices:** An up-to-date materials inventory can keep material costs down by preventing overstocking, track how materials are stored and handled onsite, and identify which materials and activities pose the most risk to the environment. Assign responsibility of hazardous material inventory to individuals trained to handle such materials. A material inventory should include these steps:

- Identify all chemical substances present at work site. Perform a walk-through of the site, review purchase orders, list all chemical substances used and obtain Material Safety Data Sheets (MSDSs) for all chemicals.
- Label all containers with name and type of substance, stock number, expiration date, health hazards, handling suggestions, and first aid information. Find info on the SDS.
- Clearly identify special handling, storage, use and disposal considerations for hazardous materials on the material inventory.
- Institute a shelf-life program to improve material tracking and inventory to reduce the amount of materials overstocked and ensure proper disposal of expired materials. Careful tracking of materials ordered can result in more efficient materials use. Decisions on the amounts of hazardous materials that are stored on site should include an evaluation-of any emergency control systems that are in place. All storage areas for hazardous materials should be designed to contain spills.

**Practice Procedures for Training and Participation:** Provide frequent and proper training in good housekeeping techniques to reduce mishandling of chemicals or equipment. Educate by:

- Discussing good housekeeping practices in training programs and meetings.
- Publicizing pollution prevention concepts through posters or signs.
- Posting bulletin boards with updated good housekeeping procedures and tips.

## 4.4 Vehicle Maintenance, Fueling and Storage

### Vehicle Maintenance, Fueling and Storage

*Permanent*                       *Temporary*

**Description:** Areas where vehicles are fueled, maintained, and stored/parked can be pollutant "hot spots" that can result in hydrocarbons, trace metals, and other pollutants being transported in precipitation runoff. Proper fueling operations, storage of automotive fluids and effective spill cleanup procedures can help reduce contamination of stormwater runoff from vehicle maintenance and fueling facilities. Fuel-related spills can occur due to lack of attention during fueling or "topping off" fuel tanks. Common activities at construction sites include vehicle fluid

replacement and equipment replacement and repair. Some of the wastes generated maintaining automobiles include solvents (degreasers, paint thinners, etc.), antifreeze, brake fluid, brake pad dust, battery acid, motor oil, fuel, and lubricating grease.

**Uses:** procedures are applicable to vehicle maintenance and fueling. Vehicle wash water is considered process wastewater that will not be discharged to the storm sewer system.

**Practice Procedures for Vehicle Maintenance:** The most effective way to minimize wastes generated by automotive maintenance activities is to prevent their production in the first place. The following practices will be implemented:

- Perform maintenance activities offsite whenever possible or inside and/or under cover. When repairs cannot be performed indoors, use drip pans or absorbents.
- Keep equipment clean and free of excessive oil and grease buildup.
- Promptly cleanup spills using dry methods and properly dispose of waste. When water is required, use as little as possible to clean spills, leaks, and drips.
- Use a solvent collection service to collect spent solvent used for parts cleaning.
- When using liquids for cleaning, use a centralized station to ensure that solvents and residues stay in one area. Locate drip pans and draining boards to direct solvents back into a solvent sink or holding tank for reuse.
- Store used oil for recycling in labeled tanks. Locate used oil tanks and drums away from storm sewer, flowing streams, and preferably indoors.
- Use non-hazardous or less hazardous alternatives when practical. For example, replace chlorinated organic solvents with non-chlorinated ones like kerosene or mineral spirits.
- Properly recycle or dispose of grease, oil, antifreeze, brake fluid, cleaning solutions, hydraulic fluid, batteries, transmission fluid, worn parts, filters, and rags.
- Drain and crush oil filters before recycling or disposal.
- Drain all fluids and remove batteries from salvage vehicles and equipment.
- Closely monitor parked vehicles for leaks and place pans under leaks to collect the fluids for proper disposal or recycling. Remove defective equipment until repaired.
- Install berms or other measures to contain spills and prevent work surface runoff from entering storm sewer system.
- Develop a spill prevention plan with measures such as spill kits, and information about location of storm drains and how to protect them if a large spill occurs.
- Conduct periodic employee training to reinforce proper disposal practices.
- Promptly transfer used fluids to recycling drums or hazardous waste containers.
- Store cracked batteries in leak-proof secondary containers.
- Inspect outdoor storage areas regularly for drips, spills and improperly stored materials (for example: unlabeled containers, auto parts that might contain grease or fluids, etc). This is particularly important for parking areas for vehicles awaiting repair.
- Structural CCMs, such as traps, installed in vehicle hotspot areas require routine cleanout of oil and grease. During heavy rainfall, cleanout is required more often to ensure that pollutants are not washed through the trap. Sediment removal is also required on a regular basis to keep the CCM working efficiently.

**Practice Procedures for Vehicle Fueling:**

- Perform fueling operations offsite whenever possible.
- Fueling areas should be designed to prevent stormwater runoff and spills. Fuel-dispensing areas should be paved with concrete or equivalent impervious surface, with an adequate

slope to prevent ponding, and separated from the rest of the site by a grade break or berm to prevent run-on of precipitation.

- For sites using a mobile fuel truck, establish a designated fueling area. Place temporary "caps" over nearby catch basins or manhole covers so that if a spill occurs, it is prevented from entering the storm sewer. Secondary containment should be used when transferring fuel from the tank truck to the fuel tank. Cover storm drains in the vicinity. Install vapor recovery nozzles to help control drips, and reduce air pollution.
- Keep spill response information and spill cleanup materials onsite and readily available.
- Employ dry cleanup methods cleaning up fuel spills. Such methods include sweeping to remove litter and debris, and using rags and absorbents for leaks and spills.
- Water should not be used to wash fuel spill areas. During routine cleaning, use a damp cloth on the pumps and a damp mop on the pavement. Fuel dispensing nozzles should be fitted with automatic shutoff except where prohibited by fire department. Post signs at the fuel dispenser warning operators against "topping off" vehicle fuel tanks.
- Provide written procedures describing CCMs to employees who will be fueling.

---

## 4.5 Street Sweeping and Cleaning

---

### Street Sweeping (SS)

---

*Permanent*

*Temporary*

**Description:** SS uses either manual or mechanical pavement cleaning practices to collect or vacuum sediment, litter and other debris from the streets before being washed into storm sewers by runoff. This practice can reduce pollutant loading to receiving waters, reduce clogging of storm sewer pipes, prolong the life of infiltration CCMs and reduce clogging of outlet structures in detention ponds. Mechanical designs include: broom and conveyor belt sweeper, wet or dry vacuum-assisted sweepers, and regenerative-air sweepers. The effectiveness depends upon particle loadings being swept, street texture, moisture conditions, parked cars, equipment conditions and frequency of cleaning.

**Uses:** SS is a technique in urban areas where sediment and litter accumulated on streets is of concern for aesthetic, sanitary, water and air quality reasons. SS is required at construction sites per SWMP to reduce off-site tracking.

**Procedures:**

1. SS may be performed manually (broom and/or shovel) or with a vacuum sweeper (no kick-broom). Choose the most effective approach for site conditions.
2. SS shall be completed when there is sediment tracking from the construction site exits into the public road or right-of-way.
3. SS frequency depends on presence of sediment tracking. If tracking is occurring, either a VTC shall be installed, the VTC needs maintenance, or the VTC is inadequate; all require SWMP updates.
4. Off-site sediment tracking from the construction site shall be swept immediately.

5. Conduct SS prior to precipitation events.
6. Operate sweepers at manufacturer recommended optimal speed levels.
7. Regularly inspect vehicles and equipment for leaks and repair promptly.
8. Keep accurate logs of number of curb-miles swept and amount of waste collected.
9. Dispose of SS debris and dirt at a landfill.
10. Do not store swept material along the side of the street or near a storm drain inlet.

**Site-specific information here:**

---

The right-of-way of Federal Drive is to be kept clean at all times. There is a Private roadway to the south and west of the Site that are to be kept clean with end of day street sweeping during construction until project close out.

---

## 4.6 Storm Sewer Cleaning

---

### Storm Sewer System Cleaning (SSC)

---

*Permanent*

*Temporary*

**Description:** Periodic storm sewer cleaning can help remove accumulated sediment, trash, and other pollutants from the storm system including inlets, pipes and also construction CCMs. Routine cleaning reduces the amount of pollutants in the storm system and in receiving waters. Clogged drains can cause overflow, leading to increase erosion. Cleaning increases dissolved oxygen, reduces levels of bacteria, and supports in-stream habitat. Areas with flat grades or low flows should be given special attention because they rarely achieve high enough flows to flush themselves. Water used in storm drain cleaning must be collected and properly disposed of, typically at a sanitary wastewater treatment facility. Simpler methods in localized areas can also include manual trash collection and shoveling sediment and debris from inlets and outlets. Frequency and prioritization of storm sewer cleaning is affected by the activity and intensity of construction and the proper installation and maintenance for construction CCMs.

**Uses:** Inspection of the existing storm system is recommended prior construction to document condition. The storm sewer shall be cleaned at minimum at completion of construction.

**Practice Guidelines:** Inspect the storm system as part of the required stormwater inspection.

- **Technology available:** manual cleaning (shovel), vacuum cleaning and vacuum combination jet cleaning. Choose the most effective approach for site conditions.
- **Staff training:** train about maintenance, waste collection and disposal methods.
- **Waste disposal:** Most catch basin waste is acceptable for landfills. If hazardous material is suspected, it should be tested and disposed of accordingly.

**Site specific information here:**

---

Protection of the existing private dual CDOT type C storm inlets on site is to occur during early stages of construction. Following the reconstruction of the structures to raise the grate rim elevations to final grade conditions, any necessary cleaning is to take place within the structure and connected pipes should any sediment or trash be identified. Continued protection of the structures is to take place during construction.

---

# SECTION 5: FINAL STABILIZATION

## 5.1 Final Stabilization Requirement

Final Stabilization is reached when all ground disturbing activities are complete, and all disturbed areas have either been built on, paved over or a uniform vegetative cover has been established in accordance with SWMP requirements. Prior to closing the State Stormwater Permit, all the items listed below must be completed in order for the construction site to be considered to have reached a state of final stabilization.

1. The site has a uniform vegetative cover with a density of at least 70% compared to the original undisturbed site. Such cover must be capable of adequately controlling soil erosion.
2. If applicable, proper installation and maintenance of all approved, permanent, post-construction stormwater quality treatment drainage facilities.
3. Removal of all stockpiles of soil, construction material/debris, construction equipment, etc. from the construction site.
4. Streets, parking lots and other surrounding paved surfaces are clean and free of any sediment or debris.
5. Removal of sediment, debris or other pollutants within the private and adjacent public storm drainage system.
6. Restoration of any damaged public infrastructure caused by the construction activities.

## 5.2 Final Stabilization Measures

Final stabilization efforts generally consist of a mix of many of the same temporary erosion control measures covered previously in Section 2.2. More specifically, these include:

- Surface Roughening (SR)
- Temporary or Permanent Seeding
- Mulching

At the contactors' option, hydroseeding / mulching may be employed

<b>Hydroseeding / Hydromulching (HS)</b>	
<input checked="" type="checkbox"/> <b>Permanent</b>	<input type="checkbox"/> <b>Temporary</b>
<b>What: Description</b>	Hydraulically applied mulch is an interim and permanent stabilization control measure that consists of using hydroseeding equipment to apply a uniform layer of natural fibers and adhesive-like compounds over disturbed construction areas. Hydroseeding immediately protects disturbed areas from rainfall impacts, excessive infiltration, and wind erosion until permanent vegetation is established.

<b>When: Installation</b>	As soon as possible or as necessary to protect disturbed soils and / or to initiate germination and site stabilization through establishment of vegetative cover
<b>Where: Location</b>	All disturbed areas. Best used on dry areas where slopes are no greater than 2:1 H:V. Not suitable on saturated soils or in areas of concentrated flows
<b>How: Maintenance &amp; Inspection</b>	Visually inspect at regular intervals and after every storm event to ensure mulch meets required coverage. Re-apply hydraulic mulch as needed over failed areas (e.g., large slopes after storm event) throughout the construction period to ensure continuous coverage. Mulching does not need to be removed as it will biodegrade with time.

### 5.3 Removal of Temporary CCMs

Once the site has achieved a state of final stabilization, any remaining temporary CCMs such as perimeter controls, inlet protection, silt fence, etc. shall be removed and disposed of properly. Due to the liner nature of the project, portions of the site may reach final stabilization before others. As a result, project closeouts may be Filings as conditions warrant.

### 5.4 Stormwater Permits Close-out

Submit the CDPS Stormwater Discharge Permit [Inactivation Form](#) to CDPHE.

### 5.5 Long Term Stormwater Management

Pond 2 is an existing stormwater detention facility that was constructed for water quality capture and treatment and detention of the 100-year storm event for the Filing. The existing Pond 2 is to be reconstructed for the required volume and new maintenance pathways via regrading of the sidewalls and the cut-in of pathways to access the pond bottom. The existing Pond 2 is also to be retrofit with new stormwater infrastructure to meet current standards including a new outlet structure with an orifice plate and restrictor plate on the outlet pipe, a micropool, a concrete trickle channel throughout the pond bottom and a concrete forebay at the existing inlet pipe. The existing Pond 2 footprint remains unchanged and is to remain with its current ownership and to follow the latest O&M Manual.

# SECTION 6: STORMWATER INSPECTIONS

## 6.1 Inspections

### 1. Qualified Stormwater Management Inspection Personnel:

**Identify the inspection person(s) who will be responsible for conducting stormwater inspections and describe their qualifications. This may be a third party consultant:**

Company/Developer: Challenger Homes

Contact Name: George Hart

Address: 8605 Explorer Drive Ste. 250 Colorado Springs, CO 80920

Office #: 719.598-5192      Cell #: 970.567.0199      Email: GHart@challengerhomes.com

**2. Inspection Frequency:** Inspections shall start within 7 calendar days of commencement of construction activities. The inspection schedule shall be noted in the SWMP documents and updated as necessary if the inspection schedule changes.

**Minimum Stormwater Inspection Schedule:** A thorough inspection of the site inspection shall be performed in accordance with one of the following minimum frequencies:

- At least one inspection every 7 calendar days, **or**
- At least one inspection every 14 calendar days, if post-storm event inspections are conducted within 24 hours after the end of any precipitation or snowmelt event that causes surface erosion. Post-storm inspections may be used to fulfill the 14-day routine inspection requirement.

**Post-Storm Inspections at Temporarily Idle Sites** - For permittees choosing to combine 14-day inspections and post-storm-event inspections, if no construction activities will occur following a storm event, post-storm event inspections must be conducted prior to re-commencing construction activities, but no later than 72 hours following the storm event. The delay of any post-storm event inspection must be documented in the inspection record. Routine inspections must still be conducted at least every 14 calendar days.

**Inspections at Completed Sites/Areas** - When the site, or portions of a site are awaiting establishment of a vegetative ground cover and a state of final stabilization, the permittee must conduct a thorough inspection of the stormwater management system at least once every 30 days. Post-storm event inspections are not required under this schedule. This reduced inspection schedule is allowed if all of the following criteria are met:

- i. All construction activities resulting in ground disturbance are complete;
- ii. All activities required for final stabilization, in accordance with the SWMP, have been completed, with the exception of the application of seed that has not occurred due to seasonal conditions or the necessity for additional seed application to augment previous efforts; and

- iii. The SWMP has been amended to locate those areas to be inspected in accordance with the reduced schedule allowed for in this paragraph.

The minimum inspection frequency required does not affect the permittee's responsibility to implement and maintain effective control measures as prescribed in the SWMP. Proper maintenance may require more frequent inspections.

### **3. Inspection Procedures:**

- At minimum, inspect the construction site perimeter, all disturbed area, designated haul routes, material and/or waste storage areas that are exposed to precipitation, discharge location(s), and locations where vehicles exit the site shall be inspected for evidence of, or the potential for, pollutants leaving the Permitted boundaries, entering any storm sewer system, or discharging an MS4 or State waters.
- Visually verify whether all implemented CCMs are in effective operational condition and are working as designed in their specifications to minimize pollutant discharges.
- Determine if there are new potential sources of pollutants.
- Assess the adequacy of CCMs at the site to identify areas requiring new or modified CCMs to minimize pollutant discharges.
- Identify all areas of non-compliance and implement corrective action.

### **Identify the staff or company who will be responsible for installing control measures and making repairs or corrections:**

Company/Developer: Challenger Homes

Contact Name: George Hart

Address: 8605 Explorer Drive Ste. 250 Colorado Springs, CO 80920

Office #: 719.598-5192      Cell #: 970.567.0199      Email: GHart@challengerhomes.com

### **4. Inspection Form:**

Place completed inspections in the SWMP materials kept on site or refer to where the inspections are kept electronically. At a minimum the form should document:

- Inspection date;
- Name, title, qualifications of inspector, and signature;
- weather conditions;
- Filing of construction;
- estimated acreage of disturbance at the time of inspection;
- location(s) of discharges of sediment or other pollutants from the site; location(s) of CCMs needing maintenance;
- location(s) and identification of inadequate CCMs;
- location(s) and identification of additional CCMs needed that were not in place at the time of inspection;
- description of the minimum inspection frequency;
- deviations from the minimum inspection schedule; certification statement for corrective action(s) or inspection (if no actions).



## 6.2 Inspection Sequence

### 1. Plan your stormwater inspection

- Use an appropriate inspection form. The Inspection Form is to be provided by the Contractor/QSM. The Colorado State Inspection Form can be used as a go-by for Self-Monitoring Inspections or as direct use. The Colorado State Inspection Form may be added to the SWMP at a later date if it is to be used.
- Obtain a copy of the SWMP Plan (Site Map) with CCMs locations marked.
- Plan to travel the entire project site, including discharge points from the site and any off-site support activities.
- Include the staging area / laydown yard if applicable.

### 2. Determine Inspection frequency

- Site inspections must be conducted at least once every 7; or 14 calendar days.
- If 14-day inspections, then post-storm inspections must be conducted within 24 hours after the end of any precipitation or snowmelt event that causes surface erosion.
- 30-day inspections are conducted once construction is complete, temporary stabilizations has been installed and the site is waiting to reach final stabilization.

### 3. Inspect discharge points and downstream, off-site areas

- Inspect discharge locations to determine whether erosion and sediment control measures are effective.
- Inspect nearby downstream locations.
- Walk down the street to inspect off-site areas for signs of discharges.
- Inspect down slope existing catch basins to ensure they are free of sediment and other pollutants and to ensure that they are adequately protected.

### 4. Inspect perimeter controls and slopes

- Inspect perimeter controls to determine if sediment should be removed.
- Check the structural integrity of the CCM. Determine if CCM replacement is needed.
- Inspect slopes and temporary stockpiles to determine if erosion controls are effective.

### 5. Compare CCMs in the EC Plan with the construction site conditions.

- Determine whether CCMs are in place as required by the EC plan.
- Evaluate whether CCMs have been adequately installed and maintained.
- Look for areas where CCMs are needed but are missing in the field, or are not documented on the SWMP.

### 6. Inspect construction site entrances

- Inspect the construction exits to determine if there is tracking of sediment from the site onto the street.
- Look for evidence of additional construction exits being used that are not in the SWMP or are not stabilized.
- Inspect for evidence of sediment accumulation.

## **7. Inspect sediment controls**

- Inspect any sediment basins for sediment accumulation.
- Remove sediment when it reduces the capacity of the basin by  $\frac{1}{3}$  of the design storage volume.

## **8. Inspect pollution prevention and good housekeeping practices**

- Inspect trash areas to ensure that waste is properly contained.
- Inspect material storage and staging areas to verify that potential pollutant sources are not exposed to stormwater runoff.
- Verify that concrete, paint, and stucco washouts are being used properly and are correctly sized for the volume of wash water.
- Inspect vehicle/equipment fueling and maintenance areas for signs of stormwater pollutant exposure.

## **9. Inspect for final stabilization**

- Inspect all temporary and permanent CCMs for correct application and installation with the CCM details.
- Remove sediment from the private storm sewer system - do not jet pollutants down into the public storm sewer system.

# SECTION 7: RECORDKEEPING

## 7.1 Recordkeeping

The following records shall be available at the construction site, or be on-site when construction activities are occurring:

- ✓ An updated SWMP, reflecting current conditions and CCMs.
- ✓ Keep record of SWMP/EC Plan changes made including the date and identification of the changes (\*).
- ✓ Completed inspection reports, can be placed or electronically stored and the location referenced in the appendices.
- ✓ Any document or plan incorporated by reference to the SWMP.

(\*) The SWMP must be amended when the following occurs:

- 1) A change in design, construction, operation, or maintenance of the site requiring implementation of new or revised control measures;
- 2) The SWMP proves ineffective in controlling pollutants in stormwater runoff in compliance with the permit conditions;
- 3) Control measures identified in the SWMP are no longer necessary and are removed; and
- 4) Corrective actions are taken onsite that result in a change to the SWMP.

The SWMP is viewed as a “living document” that is continuously being reviewed and modified as a part of the overall process of evaluating and managing stormwater quality issues at the Site. The Qualified Stormwater Manager shall amend the SWMP when there is a change in design, construction, O&M of the Site which would require the implementation of new or revised control measures or if the SWMP proves to be ineffective in achieving the general objectives of controlling pollutants in stormwater discharges associated with construction activity or when control measures are no longer necessary and are removed.

A notation must be included in the SWMP to identify the date of the site change, the control measure removed, or modified, the location(s) of those control measures, and any changes to the control measure(s). The permittee must ensure the site changes are reflected in the SWMP. The permittee is non-compliant with the permit until the SWMP revisions have been made

SWMP documentation required under this permit are considered reports that must be available to the public under Section 308(b) of the CWA and Section 61.5(4) of the CDPS regulations. The permittee must make plans available to members of the public upon request. However, the permittee may claim any portion of a SWMP as confidential in accordance with 40 CFR Part 2.

This project does not rely on control measures owned or operated by another entity.

Records will be retained for a minimum period of at least 3 years after the CDPHE permit is terminated.

## **SWMP APPENDICES**

Appendix A: Sediment Basin Area Calculations and Details

Appendix B: Hydrologic Soils Group Map

Appendix C: FEMA Floodplain Map

Appendix D: QSM Qualifications

Appendix E: CDHPE Brochure

Appendix F: SWMP Amendment Log

Appendix G: GEC Plan Set and Details

# **Appendix A: Sediment Basin Area Calculations and Details**

TABLE SB-1. SIZING INFORMATION FOR STANDARD SEDIMENT BASIN			
Upstream Drainage Area (rounded to nearest acre), (ac)	Basin Bottom Width (W), (ft)	Spillway Crest Length (CL), (ft)	Hole Diameter (HD), (in)
1	12 1/2	2	9/32
2	21	3	1 1/16
3	28	5	1/2
4	33 1/2	6	9/8
5	38 1/2	8	2 1/32
6	43	9	2 1/32
7	47 1/4	11	2 5/32
8	51	12	2 7/32
9	55	13	7/8
10	58 1/4	15	1 5/16
11	61	16	3 1/32
12	64	18	1
13	67 1/2	19	1 1/16
14	70 1/2	21	1 1/8
15	73 1/4	22	1 3/16

SEDIMENT BASIN INSTALLATION NOTES

1. SEE PLAN VIEW FOR:
  - LOCATION OF SEDIMENT BASIN.
  - TYPE OF BASIN (STANDARD BASIN OR NONSTANDARD BASIN).
  - FOR STANDARD BASIN, BOTTOM WIDTH W, CREST LENGTH CL, AND HOLE DIAMETER, HD.
  - FOR NONSTANDARD BASIN, SEE CONSTRUCTION DRAWINGS FOR DESIGN OF BASIN INCLUDING RISER HEIGHT H, NUMBER OF COLUMNS N, HOLE DIAMETER HD AND PIPE DIAMETER D.
2. FOR STANDARD BASIN, BOTTOM DIMENSION MAY BE MODIFIED AS LONG AS BOTTOM AREA IS NOT REDUCED.
3. SEDIMENT BASINS SHALL BE INSTALLED PRIOR TO ANY OTHER LAND-DISTURBING ACTIVITY THAT RELIES ON ON BASINS AS AS A STORMWATER CONTROL.
4. EMBANKMENT MATERIAL SHALL CONSIST OF SOIL FREE OF DEBRIS, ORGANIC MATERIAL, AND ROCKS OR CONCRETE GREATER THAN 3 INCHES AND SHALL HAVE A MINIMUM OF 15 PERCENT BY WEIGHT PASSING THE NO. 200 SIEVE.
5. EMBANKMENT MATERIAL SHALL BE COMPACTED TO AT LEAST 95 PERCENT OF MAXIMUM DENSITY IN ACCORDANCE WITH ASTM D698.
6. PIPE SCH 40 OR GREATER SHALL BE USED.
7. THE DETAILS SHOWN ON THESE SHEETS PERTAIN TO STANDARD SEDIMENT BASIN(S) FOR DRAINAGE AREAS LESS THAN 15 ACRES. SEE CONSTRUCTION DRAWINGS FOR EMBANKMENT, STORAGE VOLUME, SPILLWAY, OUTLET, AND OUTLET PROTECTION DETAILS FOR ANY SEDIMENT BASIN(S) THAT HAVE BEEN INDIVIDUALLY DESIGNED FOR DRAINAGE AREAS LARGER THAN 15 ACRES.

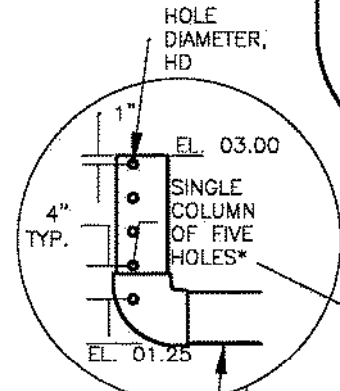
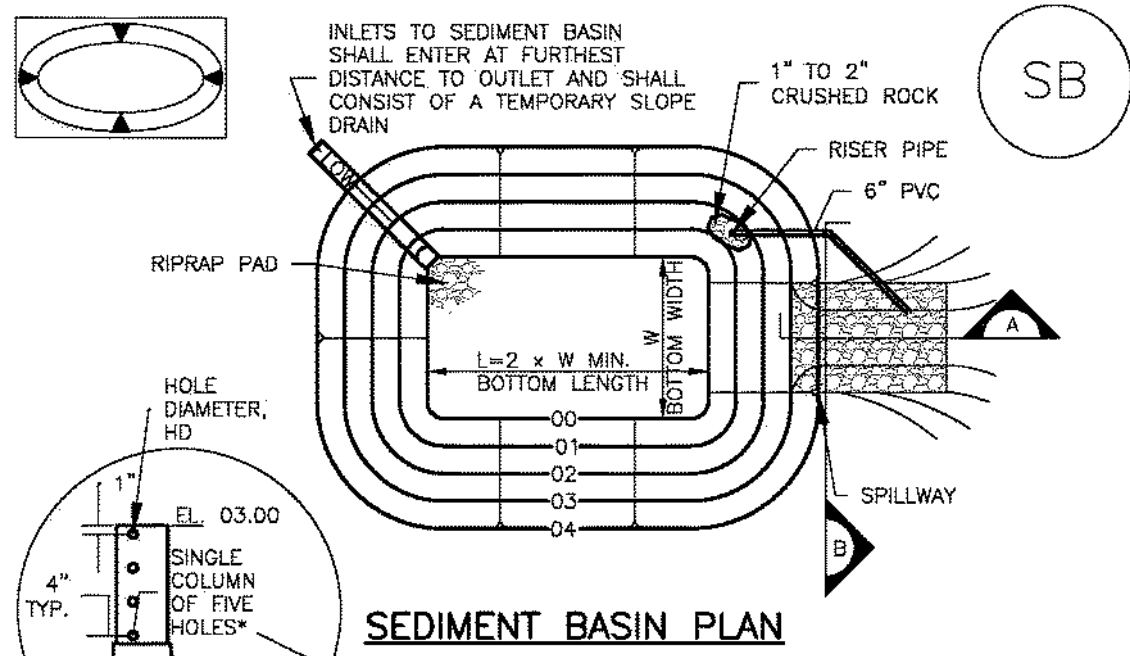

\*EXCEPT WHERE THE HOLES EXCEED 1" DIAMETER, THEN UP TO TWO COLUMNS OF SAME SIZED HOLES MAY BE USED

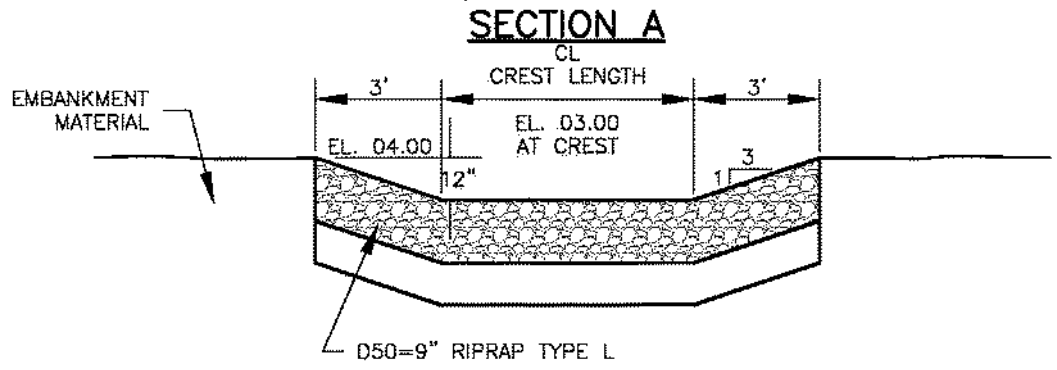
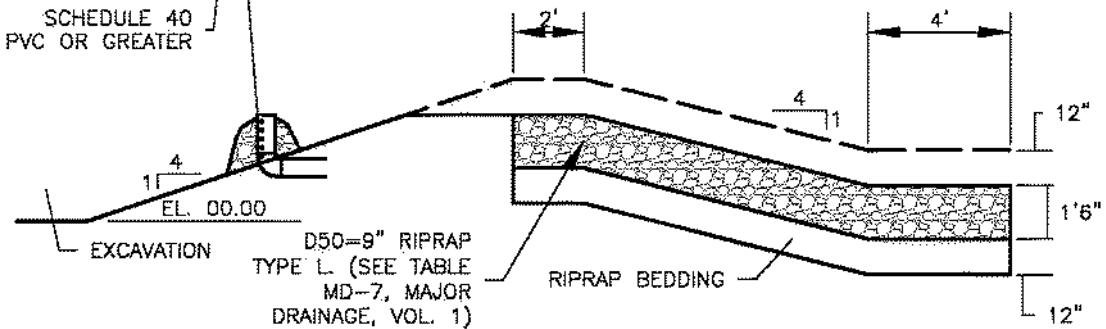

## SEDIMENT BASIN MAINTENANCE NOTES

1. INSPECT BMPs EACH WORKDAY, AND MAINTAIN THEM IN EFFECTIVE OPERATING CONDITION. MAINTENANCE OF BMPs SHOULD BE PROACTIVE, NOT REACTIVE. INSPECT BMPs AS SOON AS POSSIBLE (AND ALWAYS WITHIN 24 HOURS) FOLLOWING A STORM THAT CAUSES SURFACE EROSION, AND PERFORM NECESSARY MAINTENANCE.
2. FREQUENT OBSERVATIONS AND MAINTENANCE ARE NECESSARY TO MAINTAIN BMPs IN EFFECTIVE OPERATING CONDITION. INSPECTIONS AND CORRECTIVE MEASURES SHOULD BE DOCUMENTED THOROUGHLY.
3. WHERE BMPs HAVE FAILED, REPAIR OR REPLACEMENT SHOULD BE INITIATED UPON DISCOVERY OF THE FAILURE.
4. SEDIMENT ACCUMULATED IN BASIN SHALL BE REMOVED AS NEEDED TO MAINTAIN BMP EFFECTIVENESS, TYPICALLY WHEN SEDIMENT DEPTH REACHES ONE FOOT (I.E., TWO FEET BELOW THE SPILLWAY CREST).
5. SEDIMENT BASINS ARE TO REMAIN IN PLACE UNTIL THE UPSTREAM DISTURBED AREA IS STABILIZED AND GRASS COVER IS ACCEPTED BY THE LOCAL JURISDICTION.
6. WHEN SEDIMENT BASINS ARE REMOVED, ALL DISTURBED AREAS SHALL BE COVERED WITH TOPSOIL, SEEDED AND MULCHED OR OTHERWISE STABILIZED AS APPROVED BY LOCAL JURISDICTION.

(DETAILS ADAPTED FROM DOUGLAS COUNTY, COLORADO)

NOTE: MANY JURISDICTIONS HAVE BMP DETAILS THAT VARY FROM UDFCD STANDARD DETAILS. CONSULT WITH LOCAL JURISDICTIONS AS TO WHICH DETAIL SHOULD BE USED WHEN DIFFERENCES ARE NOTED.



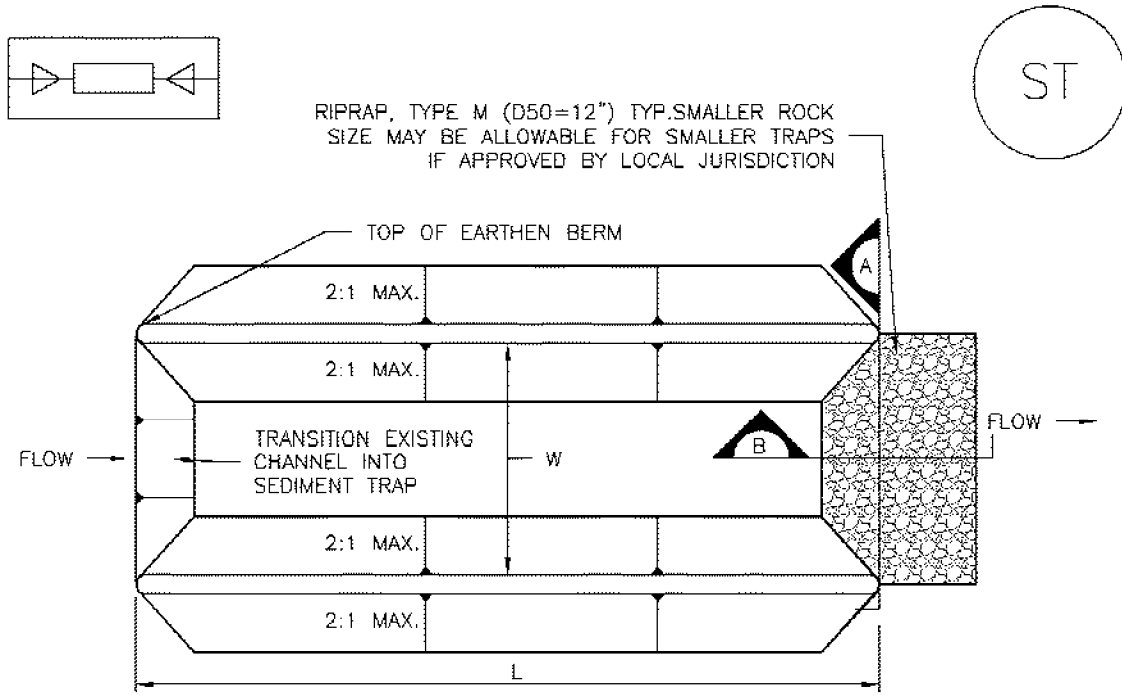

SEDIMENT TRAP PLAN

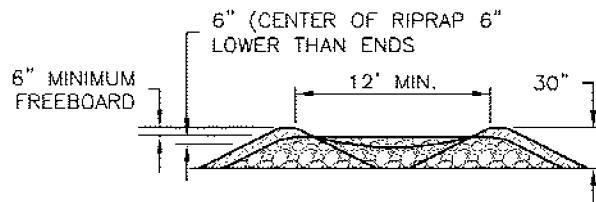

SECTION A

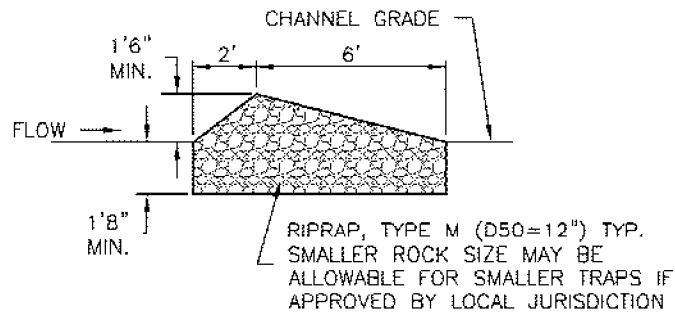

SECTION B

ST-1. SEDIMENT TRAP

<u>BMP FEATURE</u>	<u>TOTAL TRIBUTARY AREA (AC)</u>	<u>DISTURBED AREA (AC)</u>	<u>UNDISTURBED AREA (AC)</u>	<u>BOTTOM SIZE (FT)</u>	<u>SEDIMENT VOLUME (AC-FT)</u>	<u>Basin VOLUME (AC FT)</u>	<u>BOTTOM ELEVATION</u>	<u>CREST ELEVATION</u>	<u>CREST WxL (FT)</u>	<u>TOP OF POND ELEVATION</u>	<u>LOWEST ORIFICE ELEVATION</u>	<u>AREA OF ORIFICES (SQ IN)</u>	<u>DIA. OF ORIFICES (IN)</u>	<u>RISER PIPE INVERT</u>	<u>DAYLIGHT ELEVATION</u>	<u>OUTLET PIPE LENGTH (FT)</u>	<u>OUTLET PIPE SLOPE</u>
SB1	17.6	17.6	0	146' x 211'	1.09	2.35	6823.00	6825.00	12 X 126	6826	6823.55	3.06	1.97	6822.22	6821.00	126	1.0%
SB2	15.3	15.3	0	90' x 275'	0.95	2.01	6816.00	6818.00	12 x 40	6819	6816.58	2.67	1.84	6815.25	6815.00	40	0.6%
SB3	11.7	11.7	0	120' x 41'	0.97	0.71	6813.00	6818.00	12 x 65	6819.00	6816.22	1.29	1.28	6814.89	6814.00	65	1.4%
SB4	20	20	0	214' x 158'	1.24	2.66	6825.30	6827.30	12 x 48	6828.30	6825.85	3.45	2.10	6824.52	6824	102	0.5%

\*ORIFICES TO BE EVERY 3" FROM LOWEST ORIFICE ELEVATION TO THE TOP OF RISER PIPE, TOTAL NUMBER OF ORIFICES VARY.

# **Appendix B: Hydrologic Soils Group Map**

Hydrologic Soil Group—El Paso County Area, Colorado  
(Falcon Highlands Filing No. 3 - Hydrologic Soil Group Map)

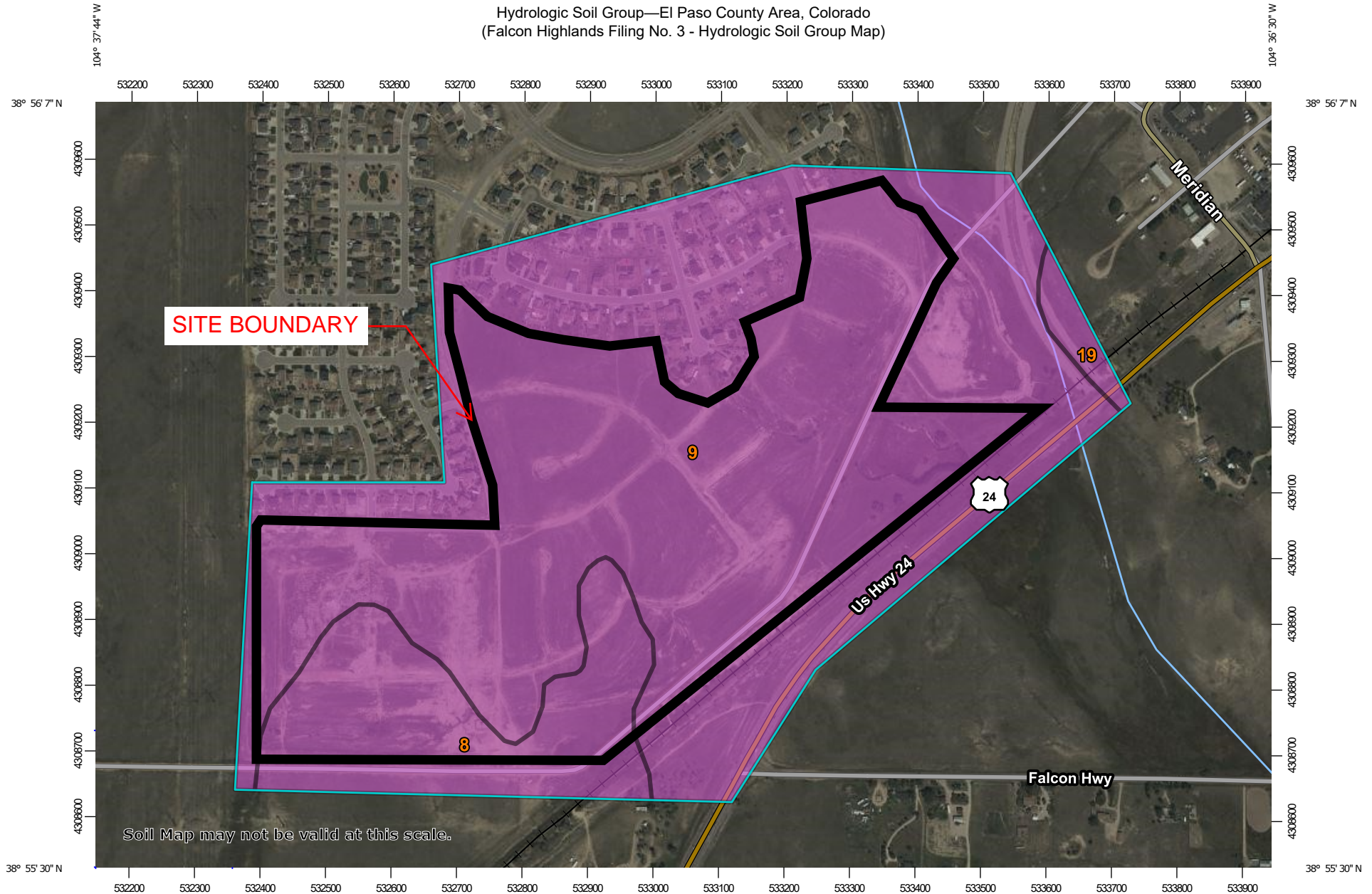

**SITE BOUNDARY**

Soil Map may not be valid at this scale.

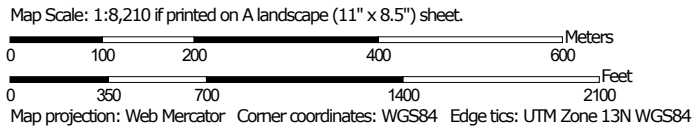

## MAP LEGEND

### Area of Interest (AOI)









 Area of Interest (AOI)

### Soils

#### Soil Rating Polygons





 A  
 A/D  
 B  
 B/D  
 C  
 C/D  
 D  
 Not rated or not available

#### Soil Rating Lines

 A  
 A/D  
 B  
 B/D  
 C  
 C/D  
 D  
 Not rated or not available

#### Soil Rating Points





 A  
 A/D  
 B  
 B/D

 C  
 C/D  
 D  
 Not rated or not available

### Water Features

 Streams and Canals

### Transportation

 Rails  
 Interstate Highways  
 US Routes  
 Major Roads  
 Local Roads

### Background

 Aerial Photography

## MAP INFORMATION

The soil surveys that comprise your AOI were mapped at 1:24,000.

Warning: Soil Map may not be valid at this scale.

Enlargement of maps beyond the scale of mapping can cause misunderstanding of the detail of mapping and accuracy of soil line placement. The maps do not show the small areas of contrasting soils that could have been shown at a more detailed scale.

Please rely on the bar scale on each map sheet for map measurements.

Source of Map: Natural Resources Conservation Service  
 Web Soil Survey URL:  
 Coordinate System: Web Mercator (EPSG:3857)

Maps from the Web Soil Survey are based on the Web Mercator projection, which preserves direction and shape but distorts distance and area. A projection that preserves area, such as the Albers equal-area conic projection, should be used if more accurate calculations of distance or area are required.

This product is generated from the USDA-NRCS certified data as of the version date(s) listed below.

Soil Survey Area: El Paso County Area, Colorado  
 Survey Area Data: Version 18, Jun 5, 2020

Soil map units are labeled (as space allows) for map scales 1:50,000 or larger.

Date(s) aerial images were photographed: Sep 11, 2018—Oct 20, 2018

The orthophoto or other base map on which the soil lines were compiled and digitized probably differs from the background imagery displayed on these maps. As a result, some minor shifting of map unit boundaries may be evident.

## Hydrologic Soil Group

Map unit symbol	Map unit name	Rating	Acres in AOI	Percent of AOI
8	Blakeland loamy sand, 1 to 9 percent slopes	A	31.0	14.2%
9	Blakeland-Fluvaquentic Haplaquolls	A	184.2	84.5%
19	Columbine gravelly sandy loam, 0 to 3 percent slopes	A	2.8	1.3%
<b>Totals for Area of Interest</b>			<b>218.0</b>	<b>100.0%</b>

## Description

Hydrologic soil groups are based on estimates of runoff potential. Soils are assigned to one of four groups according to the rate of water infiltration when the soils are not protected by vegetation, are thoroughly wet, and receive precipitation from long-duration storms.

The soils in the United States are assigned to four groups (A, B, C, and D) and three dual classes (A/D, B/D, and C/D). The groups are defined as follows:

Group A. Soils having a high infiltration rate (low runoff potential) when thoroughly wet. These consist mainly of deep, well drained to excessively drained sands or gravelly sands. These soils have a high rate of water transmission.

Group B. Soils having a moderate infiltration rate when thoroughly wet. These consist chiefly of moderately deep or deep, moderately well drained or well drained soils that have moderately fine texture to moderately coarse texture. These soils have a moderate rate of water transmission.

Group C. Soils having a slow infiltration rate when thoroughly wet. These consist chiefly of soils having a layer that impedes the downward movement of water or soils of moderately fine texture or fine texture. These soils have a slow rate of water transmission.

Group D. Soils having a very slow infiltration rate (high runoff potential) when thoroughly wet. These consist chiefly of clays that have a high shrink-swell potential, soils that have a high water table, soils that have a claypan or clay layer at or near the surface, and soils that are shallow over nearly impervious material. These soils have a very slow rate of water transmission.

If a soil is assigned to a dual hydrologic group (A/D, B/D, or C/D), the first letter is for drained areas and the second is for undrained areas. Only the soils that in their natural condition are in group D are assigned to dual classes.

## Rating Options

*Aggregation Method:* Dominant Condition

*Component Percent Cutoff:* None Specified

*Tie-break Rule:* Higher

# **Appendix C: FEMA Floodplain Map**



# National Flood Hazard Layer FIRMMette



104°37'40"W 38°56'3"N

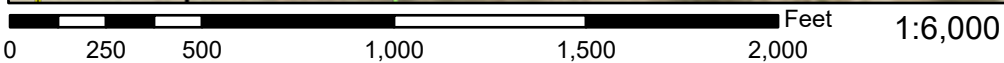

Basemap: USGS National Map: Orthoimagery: Data refreshed October, 2020

## Legend

SEE FIS REPORT FOR DETAILED LEGEND AND INDEX MAP FOR FIRM PANEL LAYOUT

SPECIAL FLOOD HAZARD AREAS		Without Base Flood Elevation (BFE) Zone A, V, A99
		With BFE or Depth Zone AE, AO, AH, VE, AR
		Regulatory Floodway
OTHER AREAS OF FLOOD HAZARD		0.2% Annual Chance Flood Hazard, Areas of 1% annual chance flood with average depth less than one foot or with drainage areas of less than one square mile Zone X
		Future Conditions 1% Annual Chance Flood Hazard Zone X
		Area with Reduced Flood Risk due to Levee. See Notes. Zone X
		Area with Flood Risk due to Levee Zone D
OTHER AREAS		NO SCREEN Area of Minimal Flood Hazard Zone X
		Effective LOMRs
GENERAL STRUCTURES		Area of Undetermined Flood Hazard Zone D
		Channel, Culvert, or Storm Sewer
		Levee, Dike, or Floodwall
OTHER FEATURES		20.2 Cross Sections with 1% Annual Chance Water Surface Elevation
		17.5 Coastal Transect
		Base Flood Elevation Line (BFE)
		Limit of Study
		Jurisdiction Boundary
MAP PANELS		Coastal Transect Baseline
		Profile Baseline
		Hydrographic Feature
		Digital Data Available
		No Digital Data Available
		Unmapped



The pin displayed on the map is an approximate point selected by the user and does not represent an authoritative property location.

This map complies with FEMA's standards for the use of digital flood maps if it is not void as described below. The basemap shown complies with FEMA's basemap accuracy standards

The flood hazard information is derived directly from the authoritative NFHL web services provided by FEMA. This map was exported on 5/21/2021 at 11:21 AM and does not reflect changes or amendments subsequent to this date and time. The NFHL and effective information may change or become superseded by new data over time.

This map image is void if the one or more of the following map elements do not appear: basemap imagery, flood zone labels, legend, scale bar, map creation date, community identifiers, FIRM panel number, and FIRM effective date. Map images for unmapped and unmodernized areas cannot be used for regulatory purposes.

**NOTES TO USERS**

This map is for use in administering the National Flood Insurance Program. It does not necessarily identify all areas subject to flooding, particularly from local drainage sources of small size. The community map repository should be consulted for possible updated or additional flood hazard information.

To obtain more detailed information in areas where **Base Flood Elevations (BFEs)** and/or **floodways** have been determined, users are encouraged to consult the Flood Profiles and Floodway Data and/or Summary of Stillwater Elevations tables contained within the Flood Insurance Study (FIS) report that accompanies this FIRM. Users should be aware that BFEs shown on the FIRM represent rounded whole-foot elevations. These BFEs are intended for flood insurance rating purposes only and should not be used as the sole source of flood elevation information. Accordingly, flood elevation data presented in the FIS report should be utilized in conjunction with the FIRM for purposes of construction and/or floodplain management.

**Coastal Base Flood Elevations** shown on this map apply only landward of 0.0' North American Vertical Datum of 1988 (NAVD88). Users of this FIRM should be aware that coastal flood elevations are also provided in the Summary of Stillwater Elevations table in the Flood Insurance Study report for this jurisdiction. Elevations shown in the Summary of Stillwater Elevations table should be used for construction and/or floodplain management purposes when they are higher than the elevations shown on this FIRM.

Boundaries of the **floodways** were computed at cross sections and interpolated between cross sections. The floodways were based on hydraulic considerations with regard to requirements of the National Flood Insurance Program. Floodway widths and other pertinent floodway data are provided in the Flood Insurance Study report for this jurisdiction.

Certain areas not in Special Flood Hazard Areas may be protected by **flood control structures**. Refer to section 2.4 "Flood Protection Measures" of the Flood Insurance Study report for information on flood control structures for this jurisdiction.

The **projection** used in the preparation of this map was Universal Transverse Mercator (UTM) zone 13. The **horizontal datum** was NAD83, GRS80 spheroid. Differences in datum, spheroid, projection or UTM zones zones used in the production of FIRMs for adjacent jurisdictions may result in slight positional differences in map features across jurisdiction boundaries. These differences do not affect the accuracy of this FIRM.

Flood elevations on this map are referenced to the **North American Vertical Datum of 1988 (NAVD88)**. These flood elevations must be compared to structure and ground elevations referenced to the same **vertical datum**. For information regarding conversion between the National Geodetic Vertical Datum of 1929 and the North American Vertical Datum of 1988, visit the National Geodetic Survey website at <http://www.ngs.noaa.gov/> or contact the National Geodetic Survey at the following address:

NGS Information Services  
NOAA, NIMS12  
National Geodetic Survey  
SSMC-3, #9202  
1315 East-West Highway  
Silver Spring, MD 20910-3282

To obtain current elevation, description, and/or location information for **bench marks** shown on this map, please contact the Information Services Branch of the National Geodetic Survey at (301) 713-3242 or visit its website at <http://www.ngs.noaa.gov/>.

**Base Map** information shown on this FIRM was provided in digital format by El Paso County, Colorado Springs Utilities, City of Fountain, Bureau of Land Management, National Oceanic and Atmospheric Administration, United States Geological Survey, and Anderson Consulting Engineers, Inc. These data are current as of 2006.

This map reflects more detailed and up-to-date **stream channel configurations and floodplain delineations** than those shown on the previous FIRM for this jurisdiction. The floodplains and floodways that were transferred from the previous FIRM may have been adjusted to conform to these new stream channel configurations. As a result, the Flood Profiles and Floodway Data tables in the Flood Insurance Study Report (which contains authoritative hydraulic data) may reflect stream channel distances that differ from what is shown on this map. The profile baselines depicted on this map represent the hydraulic modeling baselines that match the flood profiles and Floodway Data Tables if applicable, in the FIS report. As a result, the profile baselines may deviate significantly from the new base map channel representation and may appear outside of the floodplain.

**Corporate limits** shown on this map are based on the best data available at the time of publication. Because changes due to annexations or de-annexations may have occurred after this map was published, map users should contact appropriate community officials to verify current corporate limit locations.

Please refer to the separately printed **Map Index** for an overview map of the county showing the layout of map panels; community map repository addresses; and a Listing of Communities table containing National Flood Insurance Program dates for each community as well as a listing of the panels on which each community is located.

Contact **FEMA Map Service Center (MSC)** via the FEMA Map Information eXchange (FMIX) 1-877-336-2627 for information on available products associated with this FIRM. Available products may include previously issued Letters of Map Change, a Flood Insurance Study Report, and/or digital versions of this map. The MSC may also be reached by Fax at 1-800-358-9620 and its website at <http://www.msc.fema.gov/>.

If you have **questions about this map** or questions concerning the National Flood Insurance Program in general, please call **1-877-FEMA MAP** (1-877-336-2627) or visit the FEMA website at <http://www.fema.gov/business/nfip>.

El Paso County Vertical Datum Offset Table	
Flooding Source	Vertical Datum Offset (ft)
REFER TO SECTION 3.3 OF THE EL PASO COUNTY FLOOD INSURANCE STUDY FOR STREAM BY STREAM VERTICAL DATUM CONVERSION INFORMATION	

**Panel Location Map**

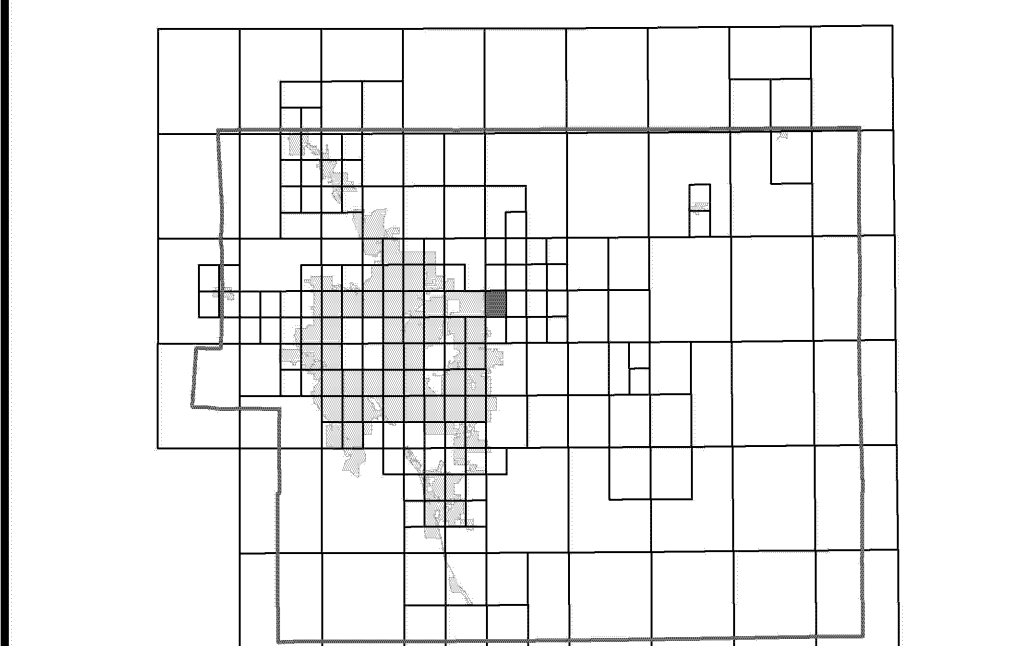

This Digital Flood Insurance Rate Map (DFIRM) was produced through a Cooperating Technical Partner (CTP) agreement between the State of Colorado Water Conservation Board (CWCB) and the Federal Emergency Management Agency (FEMA).



Additional Flood Hazard information and resources are available from local communities and the Colorado Water Conservation Board.

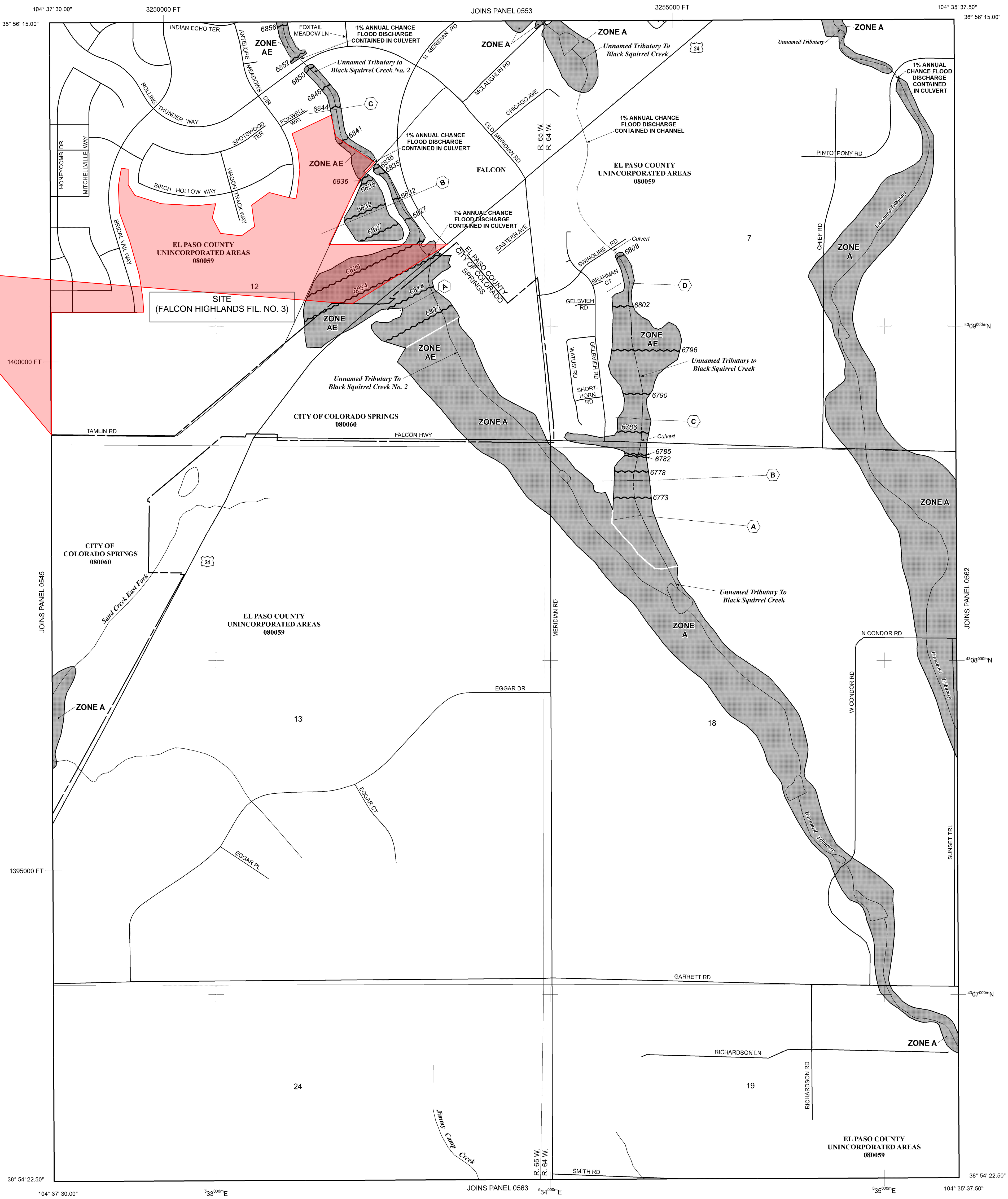

NOTE: MAP AREA SHOWN ON THIS PANEL IS LOCATED WITHIN TOWNSHIP 13 SOUTH, RANGE 64 WEST, AND TOWNSHIP 13 SOUTH, RANGE 65 WEST.

**LEGEND**

- SPECIAL FLOOD HAZARD AREAS (SFHAs) SUBJECT TO INUNDATION BY THE 1% ANNUAL CHANCE FLOOD
- The 1% annual chance flood (100-year flood), also known as the base flood, is the flood that has a 1% chance of being equalled or exceeded in any given year. The Special Flood Hazard Area is the area subject to flooding by the 1% annual chance flood. Areas of Special Flood Hazard are Zones A, AE, AH, AO, AR, A99, V, and VE. The Base Flood Elevation is the water-surface elevation of the 1% annual chance flood.
- ZONE A** No Base Flood Elevations determined. Base Flood Elevations determined.
- ZONE AE** Flood depths of 1 to 3 feet (usually areas of ponding); Base Flood Elevations determined.
- ZONE AH** Flood depths of 1 to 3 feet (usually sheet flow on sloping terrain); average depths determined. For areas of alluvial fan flooding, velocities also determined.
- ZONE AO** Special Flood Hazard Area Formerly protected from the 1% annual chance flood by a flood control system that was subsequently decertified. Zone AH indicates that the former flood control system is being restored to provide protection from the 1% annual chance or greater flood.
- ZONE AR** Area to be protected from 1% annual chance flood by a Federal flood protection system under construction; no Base Flood Elevations determined.
- ZONE A99** Coastal flood zone with velocity hazard (wave action); no Base Flood Elevations determined.
- ZONE V** Coastal flood zone with velocity hazard (wave action); Base Flood Elevations determined.
- ZONE VE** Coastal flood zone with velocity hazard (wave action); Base Flood Elevations determined.
- FLOODWAY AREAS IN ZONE AE
- The floodway is the channel of a stream plus any adjacent floodplain areas that must be kept free of encroachment so that the 1% annual chance flood can be carried without substantial increases in flood heights.
- OTHER FLOOD AREAS**
- ZONE X** Areas of 0.2% annual chance flood; areas of 1% annual chance flood with average depths of less than 1 foot, with drainage areas less than 1 square mile; and areas protected by levees from 1% annual chance flood.
- OTHER AREAS**
- ZONE X** Areas determined to be outside the 0.2% annual chance floodplain.
- ZONE D** Areas in which flood hazards are undetermined, but possible.
- COASTAL BARRIER RESOURCES SYSTEM (CBRS) AREAS
- OTHERWISE PROTECTED AREAS (OPAs)
- CBRS areas and OPAs are normally located within or adjacent to Special Flood Hazard Areas.
- Floodplain boundary
- Floodway boundary
- Zone D boundary
- CBRS and OPA boundary
- Boundary dividing Special Flood Hazard Areas of different Base Flood Elevations, flood depths or flood velocities.
- Base Flood Elevation line and value; elevation in feet\* (EL 987)
- Cross section line
- Transsect line
- Geographic coordinates referenced to the North American Datum of 1983 (NAD 83)
- 1000-meter Universal Transverse Mercator grid ticks, zone 13
- 5000-foot grid ticks: Colorado State Plane coordinate system, central zone (FIPSZONE 0502), Lambert Conformal Conic Projection
- Bench mark (see explanation in Notes to Users section of this FIRM panel)
- River Mile
- MAP REPOSITORIES**  
Refer to Map Repositories list on Map Index
- EFFECTIVE DATE OF COUNTYWIDE FLOOD INSURANCE RATE MAP**  
MARCH 17, 1997
- EFFECTIVE DATE(S) OF REVISION(S) TO THIS PANEL**  
DECEMBER 7, 2018 - to update corporate limits, to change Base Flood Elevations and Special Flood Hazard Areas, to update map format, to add roads and road names, and to incorporate previously issued Letters of Map Revision.
- For community map revision history prior to countywide mapping, refer to the Community Map History Table located in the Flood Insurance Study report for this jurisdiction.
- To determine if flood insurance is available in this community, contact your insurance agent or call the National Flood Insurance Program at 1-800-638-6620.

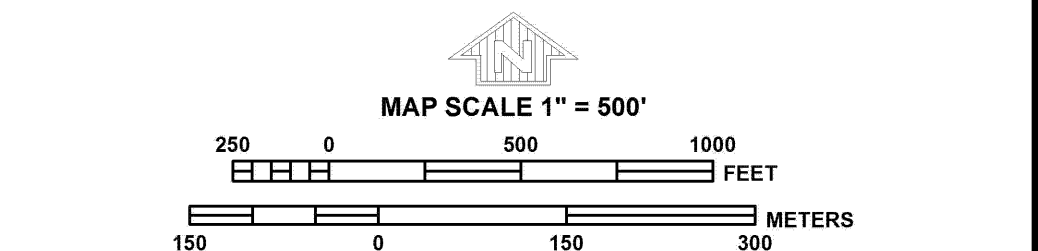

**NFIP**

**PANEL 0561G**

---

**FIRM**

**FLOOD INSURANCE RATE MAP**

**EL PASO COUNTY, COLORADO AND INCORPORATED AREAS**

**PANEL 561 OF 1300**

(SEE MAP INDEX FOR FIRM PANEL LAYOUT)

CONTAINS:	COMMUNITY	NUMBER	PANEL	SUFFIX
	EL PASO COUNTY	080059	0561	G
	EL PASO COUNTY	080059	0561	G

Notice to User: The Map Number shown below should be used when placing map orders. The Community Number shown above should be used on insurance applications for the subject community.

**MAP NUMBER**  
08041C0561G

**MAP REVISED**  
DECEMBER 7, 2018

Federal Emergency Management Agency

# **Appendix D: QSM Qualifications**

# Altitude Training Associates

Awards this Certificate of Completion to

## Karl Jones

Who on October 5, 2021 Successfully Completed  
The Following Training Class:

### Stormwater Management and Erosion Control During Construction - GEC Administrator

Certificate Number: 116



Instructor  
Altitude Training Associates



# **Appendix E: CDHPE Brochure**



## **Environmental Spill Reporting**

*24–Hour Emergency and Incident Reporting Line  
Office of Emergency Preparedness & Response*

1-877-518-5608

*Updated: June, 2018*

# Reporting chemical spills and releases in Colorado

## General

For all hazardous substance incidents, local emergency response agencies must be notified.

## Releases from fixed facilities

The Superfund Amendments and Reauthorization Act (SARA) Title III, requires reporting releases from fixed facilities

Refer to the SARA Title III List of Lists, available from the Environmental Protection Agency (EPA), for the reportable quantity.

The party that owns the spilled material must immediately notify the following agencies or organizations:

- National Response Center (NRC) 1-800-424-8802;
- Colorado Emergency Planning Committee (CEPC), represented by the Colorado Department of Public Health and Environment (CDPHE) 1-877-518-5608; and
- Local Emergency Planning Committee (LEPC) 1-720-852-6600.

In addition to telephone notification, the responsible party must also send written notification describing the release and associated emergency response to both the CEPC (in this case, CDPHE) and the LEPC.

## Releases from RCRA facilities

Emergency releases from facilities permitted under the Resource Conservation and Recovery Act (RCRA) are reportable according to the permit requirements.

The permit often requires reporting to CDPHE, even if the amount of the release is less than a reportable quantity under SARA Title III (6 CCR 1007-3 Part 264).

Permitted facilities and generators and transporters of hazardous waste are required to have and implement a contingency plan that describes the actions facility personnel must take in response to fires, explosions or any unplanned sudden or non-sudden release of hazardous waste or hazardous waste constituents to air, soil, surface or ground water at the facility (6 CCR 1007-3 Sections 261, 262, 263, 264 and 265).

Whenever there is an imminent or actual emergency situation, appropriate state or local agencies, with designated response roles as described in the contingency plan, must be notified immediately.

The National Response Center or government official designated as the regional on-scene coordinator must be notified immediately if it is determined that the facility has had a release, fire or explosion that could threaten human health or the environment outside the facility.

CDPHE and local authorities must be notified when the facility is back in compliance and ready to resume operations. In addition, the facility must send a written report to CDPHE within 15 days of any incident that requires implementation of the contingency plan. The contingency plan should include current contact information for notification and submittal of written reports.

Permitted facilities, generators and transporters that store hazardous waste must notify CDPHE within 24 hours of any release to the environment that is greater than one (1) pound and must submit a written report to CDPHE within 30 days of the release (6 CCR 1007-3).

## Transportation accidents

Transportation accidents that require reporting:

- Result in a spill or release of a hazardous substance in excess of the reportable quantity (40 CFR Part 302.6)
- Cause injury or death or cause estimated property damage exceeding \$50,000.
- Cause an evacuation of the general public lasting one or more hours.

Those that close or shut down one or more major transportation arteries or facilities or result in fire, breakage, spillage, or suspected contamination from radioactive or infectious substances must immediately be reported to the National Response Center.

Refer to the EPA SARA Title III List of Lists for those substances that have reportable quantities.

In addition to the NRC being notified, the local emergency number (9-1-1) must be called and CDPHE should be notified.

Written notification of any transportation accident involving a release of hazardous materials must be provided to the U.S. Department of Transportation within 30 days (49 CFR Part 171.16)

Since hazardous waste is a subset of hazardous materials, transporters who have discharged hazardous waste must notify the NRC and provide a written report to the US Department of Transportation as noted in the above reporting requirements.

The transporter must give immediate notice to the nearest Colorado State Patrol office (8 CCR 1507-8 HMP 5) and the nearest law enforcement agency if the accident or spill involved a vehicle (42-20-113(3) CRS).

Notification and a written report detailing the ultimate disposition of the discharge of hazardous waste must also be provided to CDPHE (6 CCR 1007-2 Section 263.30). This may be a duplicate copy of the US Department of Transportation report

In the event of a spill or discharge of hazardous waste at a transfer facility, the transporter must notify CDPHE within 24 hours if the spill exceeds 55 gallons or if there is a fire or explosion.

Within 15 days of a reportable incident, the transporter must submit a written report of the incident to CDPHE, including the final disposition of the material (6 CCR 1007-2 Section 263.40).

Releases of hazardous waste at a transfer facility may also require notification to the National Response Center and a written report to the U.S. Department of Transportation.

## Releases to water

A release of any chemical, oil, petroleum product, sewage, etc., which may enter waters of the State of Colorado (which include surface water, ground water and dry gullies or storm sewers leading to surface water) must be reported to CDPHE immediately (25-8-601 CRS).

Written notification to CDPHE must follow within five (5) days (5 CCR 1002-61, Section 61.8(5)(d)).

Any accidental discharge to the sanitary sewer system must be reported immediately to the local sewer authority and the affected wastewater treatment plant.

Releases of petroleum products and certain hazardous substances listed under the Federal Clean Water Act (40 CFR Part 116) must be reported to the National Response Center as well as to CDPHE (1-877-518-5608) as required under the Clean Water Act and the Oil Pollution Act.

## Releases to air

Any unpredictable failure of air pollution control or process equipment that results in the violation of emission



control regulations should be reported CDPHE by 10 a.m. of the following working day, followed by a written notice explaining the cause of the occurrence and describing action that has been or is being taken to correct the condition causing the violation and to prevent such excess emissions in the future (5 CCR 1001-2 Common Provisions Regulations Section II.E).

If emergency conditions cause excess emissions at a permitted facility, the owner/operator must provide notice to CDPHE no later than noon of the next working day following the emergency, and follow by written notice within one month of the time when emission limitations were exceeded due to the emergency (5 CCR 1001-5, Regulation 3 Part C, Section VII.C.4).

## Releases from oil and gas wells

All spills or releases of exploration and production wastes or produced fluids which meet the reporting thresholds of the Colorado Oil and Gas Conservation Commission (COGCC) Rule 906 shall be reported verbally to the COGCC within 24 hours of discovery and on the COGCC Spill/Release Report Form 19 within 72 hours of discovery.

Spills or releases are reportable to the COGCC in the following circumstances:

- 1) the spill or release impacts or threatens to impact any waters of the state, (which include surface water, ground water and dry gullies or storm sewers leading to surface water), a residence or occupied structure, livestock or a public byway;
- 2) a spill or release in which 1 barrel or more is released outside of berms or other secondary containment; or
- 3) any spill or release of 5 barrels or more.

COGCC also requires reportable spills or releases be reported to the surface owner and local government. Whether or not they are reportable, spills or releases of any size must be stopped, cleaned up, and investigated as soon as practicable.

If the spill or release impacts or threatens to impact waters of the state, it must also be reported immediately to CDPHE (25-8-601 CRS).

## Releases from storage tanks

Petroleum releases of 25 gallons or more (or any size that causes a sheen on nearby surface waters) from regulated aboveground and underground fuel storage tanks must be reported to the Division of Oil and Public Safety (303-318-8547) within 24 hours. If the report is made after business hours, please leave a message on the technical assistance line for the Division of Oil and Public Safety, and contact the 24 hour CDPHE Emergency and Incident Reporting Line. This includes spills from fuel dispensers.

Spills or releases of hazardous substances from regulated storage tanks in excess of the reportable quantity (40 CFR Part 302.6) must be reported to the National Response Center and the local fire authority immediately, and to the Division of Oil and Public Safety within 24 hours. (8-20.5-208 CRS and 7 CCR 1101-14 Article 4).

Owners/operators of regulated storage tanks must contain and immediately clean up a spill or overfill of less than 25 gallons of petroleum and a spill or overfill of a hazardous substance that is less than the reportable quantity.

If cleanup cannot be accomplished within 24 hours, the Division of Oil and Public Safety must be notified immediately (7 CCR 1101-14 Article 4-4).

CDPHE should also be notified in the case of hazardous substance releases as cleanup activities may be covered by state solid or hazardous waste requirements (6 CCR 1007-2, 6 CCR 1007-3).

Any release that has or may impact waters of the state (which include surface water, ground water and dry

gullies or storm sewers leading to surface water), no matter how small, must be reported immediately to CDPHE (25-8-601 CRS).

## Releases from pipelines

Releases of five or more gallons of hazardous liquids or carbon dioxide from a pipeline that result in explosion or fire, cause injury or death or cause estimated property damage (including cost of clean-up and recovery, value of lost product and property damage) exceeding \$50,000 must be reported immediately to the US Department of Transportation Office of Pipeline Safety (49 CFR Part 195 Subpart B) and the National Response Center.

Releases of five or more gallons of hazardous liquids or carbon dioxide from interstate pipelines that do not involve explosion or fire, injury or death or property damage exceeding \$50,000 should be reported to the US Department of Transportation Office of Pipeline Safety within 30 days after the incident.

Releases of natural gas from intrastate pipelines that cause injury or death, property damage in excess of \$50,000 (including the cost of lost product), closure of a public road, or evacuation of 50 or more people must be reported immediately to the Colorado Public Utilities Commission, Pipeline Safety Group (4 CCR 723-11-2).

Releases of natural gas or liquefied natural gas (LNG) from interstate pipelines that cause injury or death, property damage in excess of \$50,000 (including the cost of lost product), or results in an emergency shutdown of the facility must be reported immediately to the National Response Center and the US Dept of Transportation Office of Pipeline Safety.

Releases of oil, petroleum products or other hazardous liquids from interstate and intrastate pipelines that have or may enter waters of the State of Colorado (which include surface water, ground water and dry gullies or storm sewers leading to surface water) must be reported to CDPHE immediately (25-8-601 CRS). CDPHE should also be notified of releases to soil, as cleanup activities may be covered by state solid or hazardous waste requirements (6 CCR 1007-2, 6 CCR 1007-3).

## Radiological accidents, incidents, and events

CDPHE must be notified of any condition that has caused or threatens to cause an event, which meets or exceeds the criteria specified in (6 CCR 1007-1) RH 4.51 and RH 4.52 of the State of Colorado *Rules and Regulations Pertaining to Radiation Control*. Reportable events include lost radioactive materials, lost radiation producing machines, over-exposures to persons, contamination events and fires or explosions involving radioactive materials.

Depending upon the severity of the event, notification may be required immediately, within 24 hours, or within 30 days. In most cases, a written follow-up report is also required.

If you are unsure of the proper notification requirement, please contact CDPHE immediately. Telephone event notifications can be made to the CDPHE Radiation Program at any time by calling 1-303-877-9757.

## Notification Numbers

Colorado Department of Public Health and Environment toll-free 24-hour environmental emergency and incident reporting line: (877) 518-5608 (24-hour)

National Response Center  
(800) 424-8802 (24-hour)

State Oil Inspector (Colorado Division of Oil & Public Safety-Above & Underground Storage Tank Regulators)  
(303) 318-8547

# **Appendix F: SWMP Amendment Log**



# **Appendix G: GEC Plan Set and Details**

3/11/22, 9:39 PM AppF-60.png (987\*1314)

STREET GRADE %	INTERVAL (FT)
0-2	500
2-4	200
4-6	120
6-8	90
8-10	70
10-12	50
12-15	35

8/11/11 Typical Check Dam Detail  
Standard Drawing  
André P. Brackin  
11/10/04 SD\_3-62

3/11/22, 3:41 PM AppF-65.png (1015\*1345)

1/1/08 Concrete Washout Structure  
Standard Drawing  
John A. McCarty  
7/17/07 SD\_3-84

SC-5 Rock Sock (RS)

SIEVE SIZE	MASS PERCENT PASSING SQUARE MESH SIEVES
NO. 4	100
2"	90 - 100
1 1/2"	20 - 55
1"	0 - 15
3/4"	0 - 5
3/8"	0 - 5

RS-1. ROCK SOCK PERIMETER CONTROL

Rock Sock (RS) SC-5

ROCK SOCK MAINTENANCE NOTES

- INSPECT BMPs EACH WORKDAY, AND MAINTAIN THEM IN EFFECTIVE OPERATING CONDITION. MAINTENANCE OF BMPs SHOULD BE PROACTIVE, NOT REACTIVE. INSPECT BMPs AS SOON AS POSSIBLE (AND ALWAYS WITHIN 24 HOURS) FOLLOWING A STORM THAT CAUSES SURFACE EROSION, AND PERFORM NECESSARY MAINTENANCE.
- FREQUENT OBSERVATIONS AND MAINTENANCE ARE NECESSARY TO MAINTAIN BMPs IN EFFECTIVE OPERATING CONDITION. INSPECTIONS AND CORRECTIVE MEASURES SHOULD BE DOCUMENTED THOROUGHLY.
- WHERE BMPs HAVE FAILED, REPAIR OR REPLACEMENT SHOULD BE INITIATED UPON DISCOVERY OF THE FAILURE.
- ROCK SOCKS SHALL BE REPLACED IF THEY BECOME HEAVILY SOILED, OR DAMAGED BEYOND REPAIR.
- SEDIMENT ACCUMULATED UPSTREAM OF ROCK SOCKS SHALL BE REMOVED AS NEEDED TO MAINTAIN FUNCTIONALITY OF THE BMP. TYPICALLY WHEN DEPTH OF ACCUMULATED SEDIMENTS IS APPROXIMATELY 1/2 OF THE HEIGHT OF THE ROCK SOCK.
- ROCK SOCKS ARE TO REMAIN IN PLACE UNTIL THE UPSTREAM DISTURBED AREA IS STABILIZED AND APPROVED BY THE LOCAL JURISDICTION.
- WHEN ROCK SOCKS ARE REMOVED, ALL DISTURBED AREAS SHALL BE COVERED WITH TOPSOIL, SEEDED AND MULCHED OR OTHERWISE STABILIZED AS APPROVED BY LOCAL JURISDICTION.

NO. 4  
100  
90 - 100  
20 - 55  
0 - 15  
0 - 5

EC-6 Rolled Erosion Control Products (RECP)

ECB-1. PIPE OUTLET TO DRAINAGEWAY  
ECB-2. SMALL DITCH OR DRAINAGEWAY

RECP-6 Urban Drainage and Flood Control District  
Urban Storm Drainage Criteria Manual Volume 3 November 2010

Roller Erosion Control Products (RECP) EC-6

ECB-3. OUTSIDE OF DRAINAGEWAY

STAKING PATTERNS BY ECB TYPE

STAKING PATTERNS BY SLOPE OR CHANNEL TYPE

November 2010 Urban Drainage and Flood Control District  
Urban Storm Drainage Criteria Manual Volume 3 RECP-7

EC-6 Rolled Erosion Control Products (RECP)

EROSION CONTROL BLANKET INSTALLATION NOTES

- SEE PLAN VIEW FOR:
  - LOCATION OF ECB.
  - TYPE OF ECB (STRAW, STRAW-COCOONUT, COCONUT, OR EXCELSIOR).
  - AREA, A, IN SQUARE YARDS OF EACH TYPE OF ECB.
- 100% NATURAL AND BIODEGRADABLE MATERIALS ARE PREFERRED FOR RECPs, ALTHOUGH SOME JURISDICTIONS MAY ALLOW OTHER MATERIALS IN SOME APPLICATIONS.
- IN AREAS WHERE ECBs ARE SHOWN ON THE PLANS, THE PERMITTEE SHALL PLACE TOPSOIL AND PERFORM FINAL GRADING, SURFACE PREPARATION, AND SEEDING AND MULCHING. SUBGRADE SHALL BE SMOOTH AND MOIST PRIOR TO ECB INSTALLATION AND THE ECB SHALL BE IN FULL CONTACT WITH SUBGRADE. NO GAPS OR VOIDS SHALL EXIST UNDER THE BLANKET.
- PERIMETER ANCHOR TRENCH SHALL BE USED ALONG THE OUTSIDE PERIMETER OF ALL BLANKET AREAS.
- JOINT ANCHOR TRENCH SHALL BE USED TO JOIN ROLLS OF ECBs TOGETHER (LONGITUDINALLY AND TRANSVERSELY) FOR ALL ECBs EXCEPT STRAW WHICH MAY USE AN OVERLAPPING JOINT.
- INTERMEDIATE ANCHOR TRENCH SHALL BE USED AT SPACING OF ONE-HALF ROLL LENGTH FOR COCONUT AND EXCELSIOR ECBs.
- OVERLAPPING JOINT DETAIL SHALL BE USED TO JOIN ROLLS OF ECBs TOGETHER FOR ECBs ON SLOPES.
- MATERIAL SPECIFICATIONS OF ECBs SHALL CONFORM TO TABLE ECB-1.
- ANY AREAS OF SEEDING AND MULCHING DISTURBED IN THE PROCESS OF INSTALLING ECBs SHALL BE RESEEDED AND MULCHED.
- DETAILS ON DESIGN PLANS FOR MAJOR DRAINAGEWAY STABILIZATION WILL GOVERN IF DIFFERENT FROM THOSE SHOWN HERE.

TYPE	COCONUT CONTENT	STRAW CONTENT	EXCELSIOR CONTENT	RECOMMENDED NETTING**
STRAW*	-	100%	-	DOUBLE/NATURAL
STRAW-COCOONUT	30% MIN	70% MAX	-	DOUBLE/NATURAL
COCONUT	100%	-	-	DOUBLE/NATURAL
EXCELSIOR	-	-	100%	DOUBLE/NATURAL

RECP-8 Urban Drainage and Flood Control District  
Urban Storm Drainage Criteria Manual Volume 3 November 2010

Roller Erosion Control Products (RECP) EC-6

EROSION CONTROL BLANKET MAINTENANCE NOTES

- INSPECT BMPs EACH WORKDAY, AND MAINTAIN THEM IN EFFECTIVE OPERATING CONDITION. MAINTENANCE OF BMPs SHOULD BE PROACTIVE, NOT REACTIVE. INSPECT BMPs AS SOON AS POSSIBLE (AND ALWAYS WITHIN 24 HOURS) FOLLOWING A STORM THAT CAUSES SURFACE EROSION, AND PERFORM NECESSARY MAINTENANCE.
- FREQUENT OBSERVATIONS AND MAINTENANCE ARE NECESSARY TO MAINTAIN BMPs IN EFFECTIVE OPERATING CONDITION. INSPECTIONS AND CORRECTIVE MEASURES SHOULD BE DOCUMENTED THOROUGHLY.
- WHERE BMPs HAVE FAILED, REPAIR OR REPLACEMENT SHOULD BE INITIATED UPON DISCOVERY OF THE FAILURE.
- ECBs SHALL BE LEFT IN PLACE TO EVENTUALLY BIODEGRADE, UNLESS REQUESTED TO BE REMOVED BY THE LOCAL JURISDICTION.
- ANY ECB PULLED OUT, TORN, OR OTHERWISE DAMAGED SHALL BE REPAIRED OR REINSTALLED. ANY SUBGRADE AREAS BELOW THE GEOTEXTILE THAT HAVE ERODED TO CREATE A VOID UNDER THE BLANKET, OR THAT REMAIN DEVOID OF GRASS SHALL BE REPAIRED, RESEEDED AND MULCHED AND THE ECB REINSTALLED.

NO. 4  
100  
90 - 100  
20 - 55  
0 - 15  
0 - 5

NOVEMBER 2010 Urban Drainage and Flood Control District  
Urban Storm Drainage Criteria Manual Volume 3 RECP-9

811 Know what's below. Call before you dig.

THE LOCATIONS OF EXISTING UNDERGROUND UTILITIES ARE SHOWN IN AN APPROXIMATE WAY ONLY AND HAVE NOT BEEN INDEPENDENTLY VERIFIED BY THE OWNER OR ITS REPRESENTATIVE. THE CONTRACTOR SHALL DETERMINE THE EXACT LOCATION OF ALL EXISTING UTILITIES BEFORE COMMENCING WORK, AND AGREES TO BE FULLY RESPONSIBLE FOR ANY AND ALL DAMAGES WHICH MIGHT BE OCCASIONED BY THE CONTRACTOR'S FAILURE TO EXACTLY LOCATE AND PRESERVE ANY AND ALL UNDERGROUND UTILITIES.

NOTICE: CONSTRUCTION SITE SAFETY IS THE SOLE RESPONSIBILITY OF THE CONTRACTOR. NEITHER THE OWNER NOR THE ENGINEER SHALL BE EXPECTED TO ASSURE ANY RESPONSIBILITY FOR SAFETY OF THE WORK OF PERSONS ENGAGED IN THE WORK, OF ANY NEARBY STRUCTURES, OR OF ANY OTHER PERSONS.

COPYRIGHT © 2022 ATWELL LLC. NO REPRODUCTION SHALL BE MADE WITHOUT THE PRIOR WRITTEN CONSENT OF ATWELL LLC.

ATWELL GROUP  
866.850.4200 www.atwell-group.com  
143 UNION BOULEVARD, SUITE 700  
LAKEWOOD, CO 80228  
303.462.1100

CHALLENGER HOMES  
8605 EXPLORER DRIVE  
SUITE 250  
COLORADO SPRINGS, CO 80920  
719-598-5192  
JIM BYERS

CHALLENGER HOMES  
FALCON HIGHLANDS SOUTH  
EL PASO COUNTY, COLORADO  
CONSTRUCTION PLANS  
GRADING AND EROSION CONTROL PLAN  
DETAIL GFCP

DATE: 8/31/2022  
SUBMITTAL TO EPIC: 07/29/2022 - RDL

REVISIONS

COUNTY FILE NO.: PUDSP-22-005  
DR: JD CH  
P.M. RDL  
JOB: 21005234  
SHEET NO. 14

**Stockpile Management (SP) MM-2**

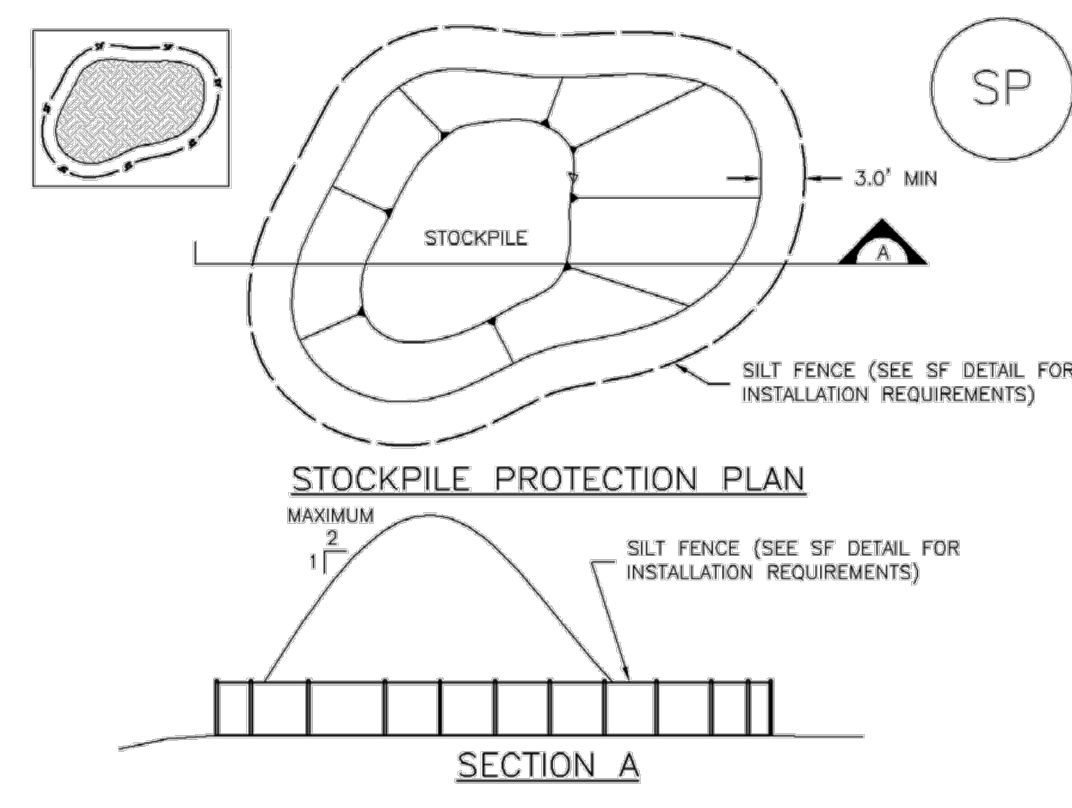

**SP-1. STOCKPILE PROTECTION**

- STOCKPILE PROTECTION INSTALLATION NOTES**
- SEE PLAN VIEW FOR:
    - LOCATION OF STOCKPILES.
    - TYPE OF STOCKPILE PROTECTION.
  - INSTALL PERIMETER CONTROLS IN ACCORDANCE WITH THEIR RESPECTIVE DESIGN DETAILS. SILT FENCE IS SHOWN IN THE STOCKPILE PROTECTION DETAILS HOWEVER, OTHER TYPES OF PERIMETER CONTROLS INCLUDING SEDIMENT CONTROL LOGS OR ROCK SOCKS MAY BE SUITABLE IN SOME CIRCUMSTANCES. CONSIDERATIONS FOR DETERMINING THE APPROPRIATE TYPE OF PERIMETER CONTROL FOR A STOCKPILE INCLUDE WHETHER THE STOCKPILE IS LOCATED ON A PERVIOUS OR IMPVIOUS SURFACE, THE RELATIVE HEIGHTS OF THE PERIMETER CONTROL AND STOCKPILE, THE ABILITY OF THE PERIMETER CONTROL TO CONTAIN THE STOCKPILE WITHOUT FAILING IN THE EVENT THAT MATERIAL FROM THE STOCKPILE SHIFTS OR SLUMPS AGAINST THE PERIMETER, AND OTHER FACTORS.
  - STABILIZE THE STOCKPILE SURFACE WITH SURFACE ROUGHENING, TEMPORARY SEEDING AND MULCHING, EROSION CONTROL BLANKETS OR SOIL BINDERS. SOILS STOCKPILED FOR AN EXTENDED PERIOD (TYPICALLY FOR MORE THAN 60 DAYS) SHOULD BE SEEDED AND MULCHED WITH A TEMPORARY GRASS COVER ONCE THE STOCKPILE IS PLACED (TYPICALLY WITHIN 14 DAYS). USE OF MULCH ONLY OR A SOIL BINDER IS ACCEPTABLE IF THE STOCKPILE WILL BE IN PLACE FOR A MORE LIMITED TIME PERIOD (TYPICALLY 30-60 DAYS).
  - FOR TEMPORARY STOCKPILES ON THE INTERIOR PORTION OF A CONSTRUCTION SITE, WHERE OTHER DOWNGRADIENT CONTROLS, INCLUDING PERIMETER CONTROL, ARE IN PLACE, STOCKPILE PERIMETER CONTROLS MAY NOT BE REQUIRED.

November 2010 Urban Drainage and Flood Control District Urban Storm Drainage Criteria Manual Volume 3 SP-3

**Stockpile Management (SM) MM-2**

- STOCKPILE PROTECTION MAINTENANCE NOTES**
- INSPECT BMPs EACH WORKDAY, AND MAINTAIN THEM IN EFFECTIVE OPERATING CONDITION. MAINTENANCE OF BMPs SHOULD BE PROACTIVE, NOT REACTIVE. INSPECT BMPs AS SOON AS POSSIBLE (AND ALWAYS WITHIN 24 HOURS) FOLLOWING A STORM THAT CAUSES SURFACE EROSION, AND PERFORM NECESSARY MAINTENANCE.
  - FREQUENT OBSERVATIONS AND MAINTENANCE ARE NECESSARY TO MAINTAIN BMPs IN EFFECTIVE OPERATING CONDITION. INSPECTIONS AND CORRECTIVE MEASURES SHOULD BE DOCUMENTED THOROUGHLY.
  - WHERE BMPs HAVE FAILED, REPAIR OR REPLACEMENT SHOULD BE INITIATED UPON DISCOVERY OF THE FAILURE.
- STOCKPILE PROTECTION MAINTENANCE NOTES**
- IF PERIMETER PROTECTION MUST BE MOVED TO ACCESS SOIL STOCKPILE, REPLACE PERIMETER CONTROLS BY THE END OF THE WORKDAY.
  - STOCKPILE PERIMETER CONTROLS CAN BE REMOVED ONCE ALL THE MATERIAL FROM THE STOCKPILE HAS BEEN USED.
- (DETAILS ADAPTED FROM PARKER, COLORADO, NOT AVAILABLE IN AUTOCAD)
- NOTE: MANY JURISDICTIONS HAVE BMP DETAILS THAT VARY FROM UDFCD STANDARD DETAILS. CONSULT WITH LOCAL JURISDICTIONS AS TO WHICH DETAIL SHOULD BE USED WHEN DIFFERENCES ARE NOTED.

SP-4 Urban Drainage and Flood Control District Urban Storm Drainage Criteria Manual Volume 3 November 2010

**Stockpile Management (SP) MM-2**

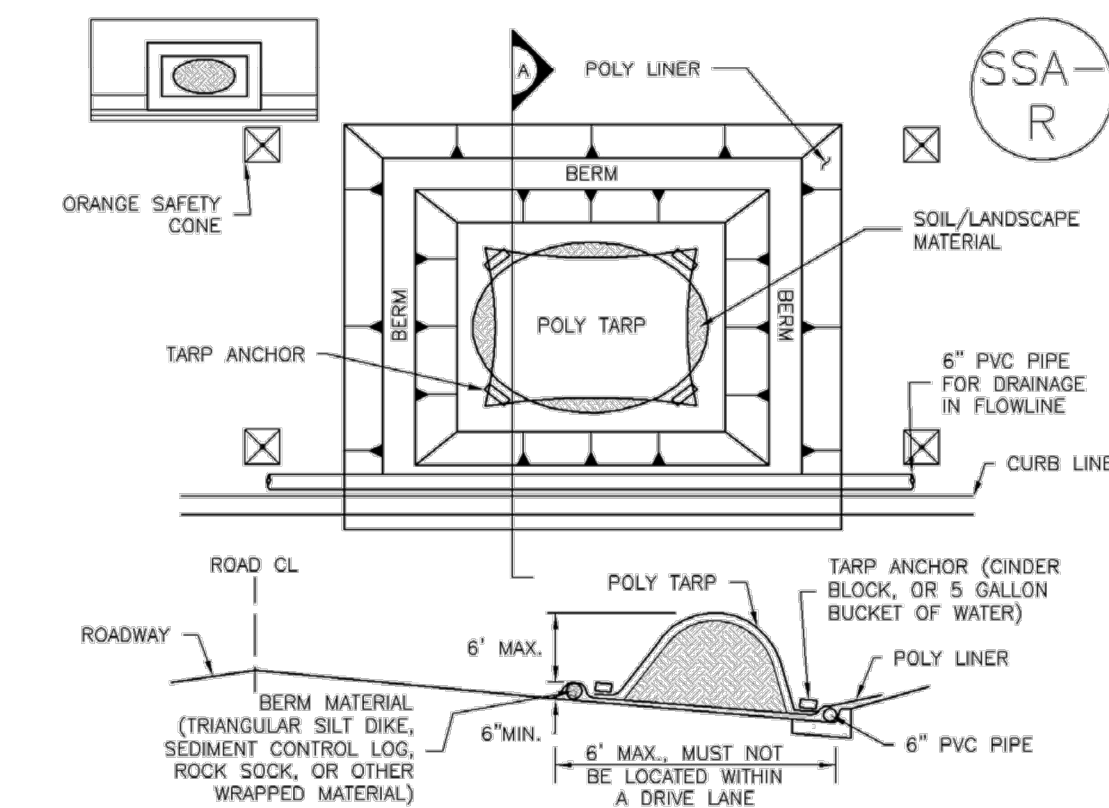

**SP-2. MATERIALS STAGING IN ROADWAY**

- MATERIALS STAGING IN ROADWAYS INSTALLATION NOTES**
- SEE PLAN VIEW FOR:
    - LOCATION OF MATERIAL STAGING AREA(S).
    - CONTRACTOR MAY ADJUST LOCATION AND SIZE OF STAGING AREA WITH APPROVAL FROM THE LOCAL JURISDICTION.
  - FEATURE MUST BE INSTALLED PRIOR TO EXCAVATION, EARTHWORK OR DELIVERY OF MATERIALS.
  - MATERIALS MUST BE STATIONED ON THE POLY LINER. ANY INCIDENTAL MATERIALS DEPOSITED ON PAVED SECTION OR ALONG CURB LINE MUST BE CLEANED UP PROMPTLY.
  - POLY LINER AND TARP COVER SHOULD BE OF SIGNIFICANT THICKNESS TO PREVENT DAMAGE OR LOSS OF INTEGRITY.
  - SAND BAGS MAY BE SUBSTITUTED TO ANCHOR THE COVER TARP OR PROVIDE BERMING UNDER THE BASE LINER.
  - FEATURE IS NOT INTENDED FOR USE WITH WET MATERIAL THAT WILL BE DRAINING AND/OR SPREADING OUT ON THE POLY LINER OR FOR DEMOLITION MATERIALS.
  - THIS FEATURE CAN BE USED FOR:
    - UTILITY REPAIRS.
    - WHEN OTHER STAGING LOCATIONS AND OPTIONS ARE LIMITED.
    - OTHER LIMITED APPLICATION AND SHORT DURATION STAGING.

November 2010 Urban Drainage and Flood Control District Urban Storm Drainage Criteria Manual Volume 3 SP-5

**Stockpile Management (SM) MM-2**

- MATERIALS STAGING IN ROADWAY MAINTENANCE NOTES**
- INSPECT BMPs EACH WORKDAY, AND MAINTAIN THEM IN EFFECTIVE OPERATING CONDITION. MAINTENANCE OF BMPs SHOULD BE PROACTIVE, NOT REACTIVE. INSPECT BMPs AS SOON AS POSSIBLE (AND ALWAYS WITHIN 24 HOURS) FOLLOWING A STORM THAT CAUSES SURFACE EROSION, AND PERFORM NECESSARY MAINTENANCE.
  - FREQUENT OBSERVATIONS AND MAINTENANCE ARE NECESSARY TO MAINTAIN BMPs IN EFFECTIVE OPERATING CONDITION. INSPECTIONS AND CORRECTIVE MEASURES SHOULD BE DOCUMENTED THOROUGHLY.
  - WHERE BMPs HAVE FAILED, REPAIR OR REPLACEMENT SHOULD BE INITIATED UPON DISCOVERY OF THE FAILURE.
  - INSPECT PVC PIPE ALONG CURB LINE FOR CLOGGING AND DEBRIS. REMOVE OBSTRUCTIONS PROMPTLY.
  - CLEAN MATERIAL FROM PAVED SURFACES BY SWEEPING OR VACUUMING.
- NOTE: MANY JURISDICTIONS HAVE BMP DETAILS THAT VARY FROM UDFCD STANDARD DETAILS. CONSULT WITH LOCAL JURISDICTIONS AS TO WHICH DETAIL SHOULD BE USED WHEN DIFFERENCES ARE NOTED.
- (DETAILS ADAPTED FROM AURORA, COLORADO)

SP-6 Urban Drainage and Flood Control District Urban Storm Drainage Criteria Manual Volume 3 November 2010

**Vehicle Tracking Control (VTC) SM-4**

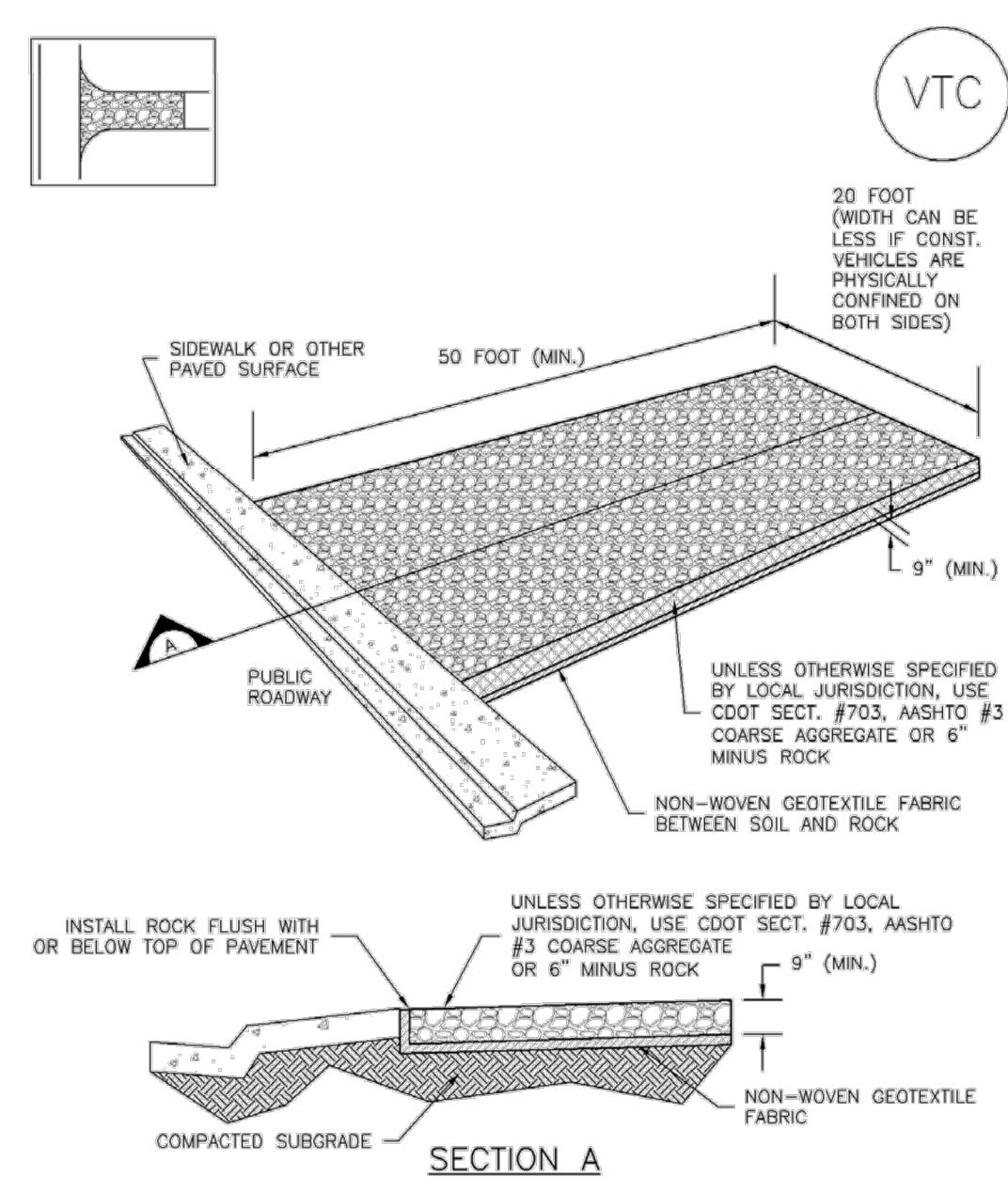

**VTC-1. AGGREGATE VEHICLE TRACKING CONTROL**

November 2010 Urban Drainage and Flood Control District Urban Storm Drainage Criteria Manual Volume 3 VTC-3

**Vehicle Tracking Control (VTC) SM-4**

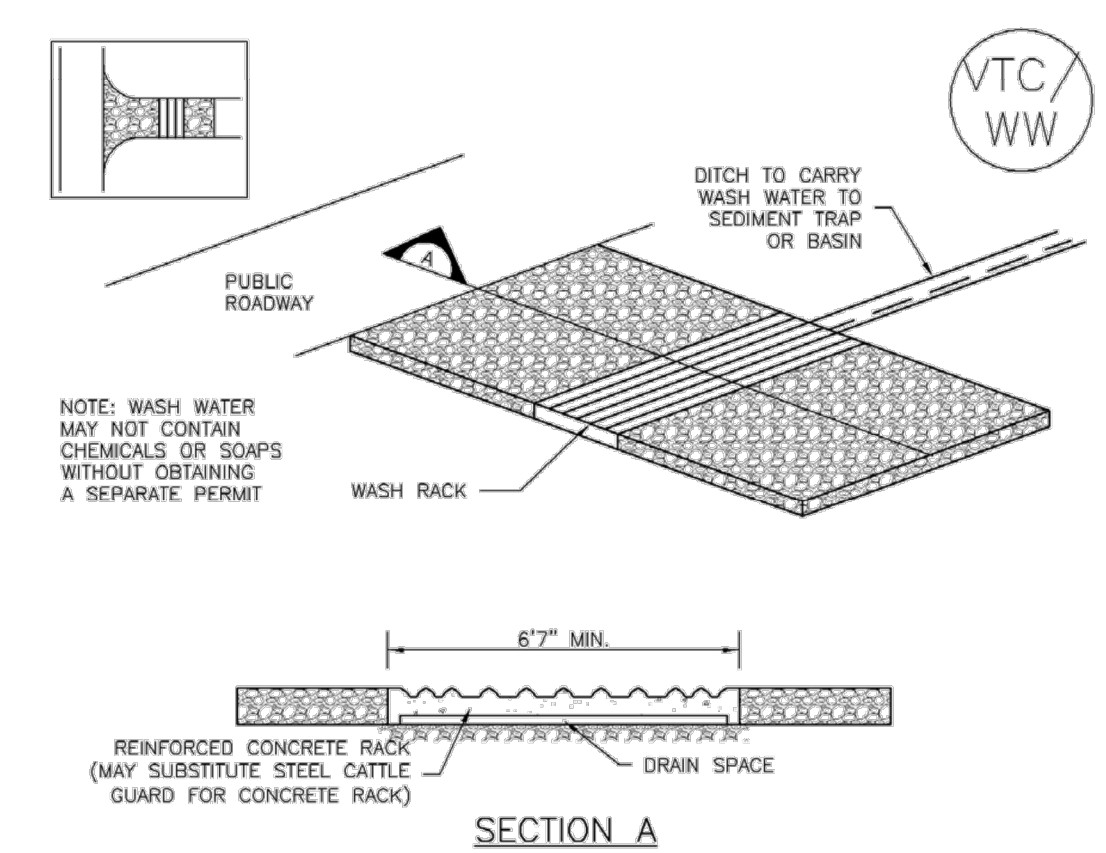

**VTC-2. AGGREGATE VEHICLE TRACKING CONTROL WITH WASH RACK**

VTC-4 Urban Drainage and Flood Control District Urban Storm Drainage Criteria Manual Volume 3 November 2010

**Vehicle Tracking Control (VTC) SM-4**

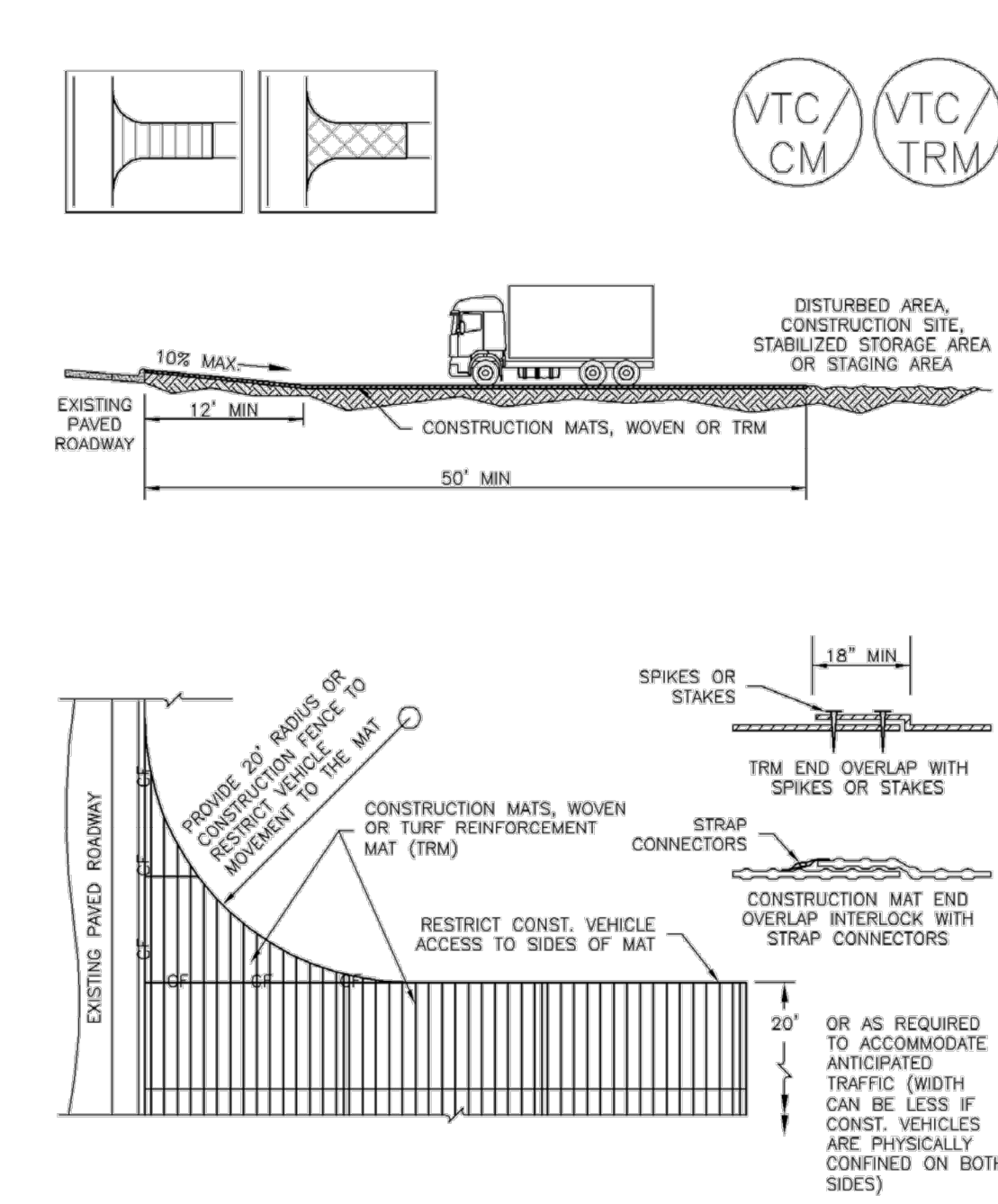

**VTC-3. VEHICLE TRACKING CONTROL W/ CONSTRUCTION MAT OR TURF REINFORCEMENT MAT (TRM)**

November 2010 Urban Drainage and Flood Control District Urban Storm Drainage Criteria Manual Volume 3 VTC-5

**Vehicle Tracking Control (VTC) SM-4**

- STABILIZED CONSTRUCTION ENTRANCE/EXIT INSTALLATION NOTES**
- SEE PLAN VIEW FOR:
    - LOCATION OF CONSTRUCTION ENTRANCE(S)/EXIT(S).
    - TYPE OF CONSTRUCTION ENTRANCE(S)/EXIT(S) (WITH/WITHOUT WHEEL WASH, CONSTRUCTION MAT OR TRM).
  - CONSTRUCTION MAT OR TRM STABILIZED CONSTRUCTION ENTRANCES ARE ONLY TO BE USED ON SHORT DURATION PROJECTS (TYPICALLY RANGING FROM A WEEK TO A MONTH) WHERE THERE WILL BE LIMITED VEHICULAR ACCESS.
  - A STABILIZED CONSTRUCTION ENTRANCE/EXIT SHALL BE LOCATED AT ALL ACCESS POINTS WHERE VEHICLES ACCESS THE CONSTRUCTION SITE FROM PAVED RIGHT-OF-WAYS.
  - STABILIZED CONSTRUCTION ENTRANCE/EXIT SHALL BE INSTALLED PRIOR TO ANY LAND DISTURBING ACTIVITIES.
  - A NON-WOVEN GEOTEXTILE FABRIC SHALL BE PLACED UNDER THE STABILIZED CONSTRUCTION ENTRANCE/EXIT PRIOR TO THE PLACEMENT OF ROCK.
  - UNLESS OTHERWISE SPECIFIED BY LOCAL JURISDICTION, ROCK SHALL CONSIST OF DOT SECT. #703, AASHTO #3 COARSE AGGREGATE OR 6" (MINUS) ROCK.
- STABILIZED CONSTRUCTION ENTRANCE/EXIT MAINTENANCE NOTES**
- INSPECT BMPs EACH WORKDAY, AND MAINTAIN THEM IN EFFECTIVE OPERATING CONDITION. MAINTENANCE OF BMPs SHOULD BE PROACTIVE, NOT REACTIVE. INSPECT BMPs AS SOON AS POSSIBLE (AND ALWAYS WITHIN 24 HOURS) FOLLOWING A STORM THAT CAUSES SURFACE EROSION, AND PERFORM NECESSARY MAINTENANCE.
  - FREQUENT OBSERVATIONS AND MAINTENANCE ARE NECESSARY TO MAINTAIN BMPs IN EFFECTIVE OPERATING CONDITION. INSPECTIONS AND CORRECTIVE MEASURES SHOULD BE DOCUMENTED THOROUGHLY.
  - WHERE BMPs HAVE FAILED, REPAIR OR REPLACEMENT SHOULD BE INITIATED UPON DISCOVERY OF THE FAILURE.
  - ROCK SHALL BE REAPPLIED OR REGRADED AS NECESSARY TO THE STABILIZED ENTRANCE/EXIT TO MAINTAIN A CONSISTENT DEPTH.
  - SEDIMENT TRACKED ONTO PAVED ROADS IS TO BE REMOVED THROUGHOUT THE DAY AND AT THE END OF THE DAY BY SHOVELING OR SWEEPING. SEDIMENT MAY NOT BE WASHED DOWN STORM SEWER DRAINS.
- NOTE: MANY JURISDICTIONS HAVE BMP DETAILS THAT VARY FROM UDFCD STANDARD DETAILS. CONSULT WITH LOCAL JURISDICTIONS AS TO WHICH DETAIL SHOULD BE USED WHEN DIFFERENCES ARE NOTED.
- (DETAILS ADAPTED FROM CITY OF BROOMFIELD, COLORADO, NOT AVAILABLE IN AUTOCAD)

VTC-6 Urban Drainage and Flood Control District Urban Storm Drainage Criteria Manual Volume 3 November 2010

**811**  
Know what's below. Call before you dig.

THE LOCATIONS OF EXISTING UNDERGROUND UTILITIES ARE SHOWN IN AN APPROXIMATE WAY ONLY AND HAVE NOT BEEN INDEPENDENTLY VERIFIED BY THE OWNER OR ITS REPRESENTATIVE. THE CONTRACTOR SHALL DETERMINE THE EXACT LOCATION OF ALL EXISTING UTILITIES BEFORE COMMENCING WORK, AND AGREES TO BE FULLY RESPONSIBLE FOR ANY AND ALL DAMAGES WHICH MIGHT BE OCCASIONED BY THE CONTRACTOR'S FAILURE TO EXACTLY LOCATE AND PRESERVE ANY AND ALL UNDERGROUND UTILITIES.

NOTICE: CONSTRUCTION SITE SAFETY IS THE SOLE RESPONSIBILITY OF THE CONTRACTOR, NEITHER THE OWNER NOR THE ENGINEER SHALL BE EXPECTED TO ASSUME ANY RESPONSIBILITY FOR SAFETY OF THE WORK OF PERSONS ENGAGED IN THE WORK, OF ANY NEARBY STRUCTURES, OR OF ANY OTHER PERSONS.

COPYRIGHT © 2022 ATWELL LLC. NO REPRODUCTION SHALL BE MADE WITHOUT THE PRIOR WRITTEN CONSENT OF ATWELL LLC.

**ATWELL**  
www.atwell-group.com  
866.850.4200  
143 UNION BOULEVARD, SUITE 700  
LAKEWOOD, CO 80228  
303.462.1100

**CHALLENGER HOMES**  
8605 EXPLORER DRIVE  
SUITE 250  
COLORADO SPRINGS, CO 80920  
719-598-5192  
JIM BYERS

**CHALLENGER HOMES**  
FALCON HIGHLANDS SOUTH  
EL PASO COUNTY, COLORADO  
CONSTRUCTION PLANS  
GRADING AND EROSION CONTROL PLAN  
DETAIL GPCP

CLIENT: CHALLENGER HOMES

DATE: 8/31/2022

A 1st SUBMITTAL TO EPC 07/29/2022 - RDL

REVISIONS:

COUNTY FILE NO.: PUDSP-22-005

DR: JD CH.

P.M. RDL

JOB: 21005234

SHEET NO. 15

CAD FILE: 21005234-GECP-DETAILS.DWG

Silt Fence (SF)

SC-1

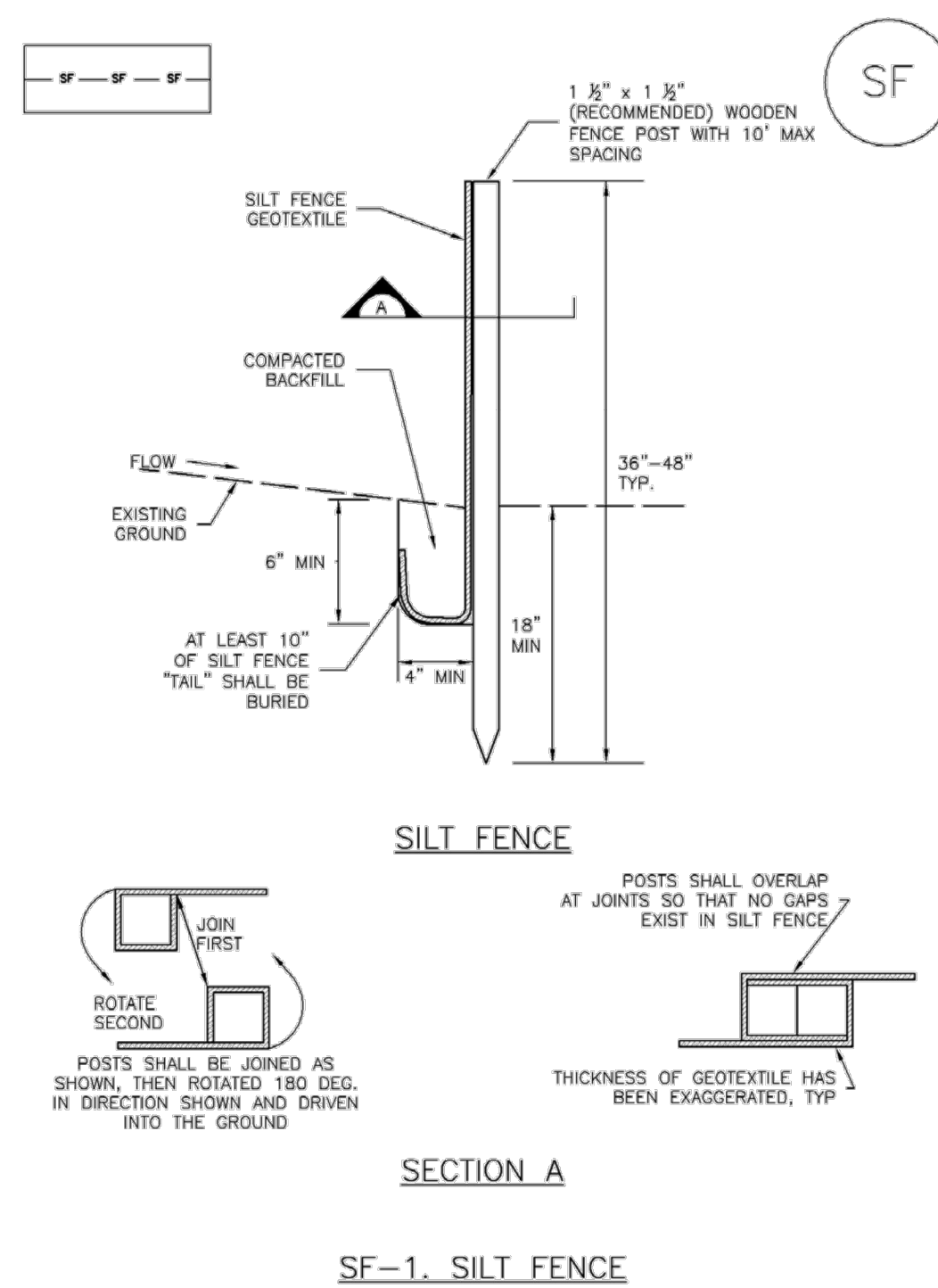

November 2010 Urban Drainage and Flood Control District Urban Storm Drainage Criteria Manual Volume 3 SF-3

SC-1

Silt Fence (SF)

SILT FENCE INSTALLATION NOTES

- SILT FENCE MUST BE PLACED AWAY FROM THE TOE OF THE SLOPE TO ALLOW FOR WATER PONDING. SILT FENCE AT THE TOE OF A SLOPE SHOULD BE INSTALLED IN A FLAT LOCATION AT LEAST SEVERAL FEET (2-5 FT) FROM THE TOE OF THE SLOPE TO ALLOW ROOM FOR PONDING AND DEPOSITION.
- A UNIFORM 6" X 4" ANCHOR TRENCH SHALL BE EXCAVATED USING TRENCHER OR SILT FENCE INSTALLATION DEVICE. NO ROAD GRADERS, BACKHOES, OR SIMILAR EQUIPMENT SHALL BE USED.
- COMPACT ANCHOR TRENCH BY HAND WITH A "JUMPING JACK" OR BY WHEEL ROLLING. COMPACTION SHALL BE SUCH THAT SILT FENCE RESISTS BEING PULLED OUT OF ANCHOR TRENCH BY HAND.
- SILT FENCE SHALL BE PULLED TIGHT AS IT IS ANCHORED TO THE STAKES. THERE SHOULD BE NO NOTICEABLE SAG BETWEEN STAKES AFTER IT HAS BEEN ANCHORED TO THE STAKES.
- SILT FENCE FABRIC SHALL BE ANCHORED TO THE STAKES USING 1" HEAVY DUTY STAPLES OR NAILS WITH 1" HEADS. STAPLES AND NAILS SHOULD BE PLACED 3" ALONG THE FABRIC DOWN THE STAKE.
- AT THE END OF A RUN OF SILT FENCE ALONG A CONTOUR, THE SILT FENCE SHOULD BE TURNED PERPENDICULAR TO THE CONTOUR TO CREATE A "U-HOOK". THE "U-HOOK" EXTENDING PERPENDICULAR TO THE CONTOUR SHOULD BE OF SUFFICIENT LENGTH TO KEEP RUNOFF FROM FLOWING AROUND THE END OF THE SILT FENCE (TYPICALLY 10' - 20').
- SILT FENCE SHALL BE INSTALLED PRIOR TO ANY LAND DISTURBING ACTIVITIES.

SILT FENCE MAINTENANCE NOTES

- INSPECT BMPs EACH WORKDAY, AND MAINTAIN THEM IN EFFECTIVE OPERATING CONDITION. MAINTENANCE OF BMPs SHOULD BE PROACTIVE, NOT REACTIVE. INSPECT BMPs AS SOON AS POSSIBLE (AND ALWAYS WITHIN 24 HOURS) FOLLOWING A STORM THAT CAUSES SURFACE EROSION, AND PERFORM NECESSARY MAINTENANCE.
  - FREQUENT OBSERVATIONS AND MAINTENANCE ARE NECESSARY TO MAINTAIN BMPs IN EFFECTIVE OPERATING CONDITION. INSPECTIONS AND CORRECTIVE MEASURES SHOULD BE DOCUMENTED THOROUGHLY.
  - WHERE BMPs HAVE FAILED, REPAIR OR REPLACEMENT SHOULD BE INITIATED UPON DISCOVERY OF THE FAILURE.
  - SEDIMENT ACCUMULATED UPSTREAM OF THE SILT FENCE SHALL BE REMOVED AS NEEDED TO MAINTAIN THE FUNCTIONALITY OF THE BMP, TYPICALLY WHEN DEPTH OF ACCUMULATED SEDIMENTS IS APPROXIMATELY 6".
  - REPAIR OR REPLACE SILT FENCE WHEN THERE ARE SIGNS OF WEAR, SUCH AS SAGGING, TEARING, OR COLLAPSE.
  - SILT FENCE IS TO REMAIN IN PLACE UNTIL THE UPSTREAM DISTURBED AREA IS STABILIZED AND APPROVED BY THE LOCAL JURISDICTION, OR IS REPLACED BY AN EQUIVALENT PERIMETER SEDIMENT CONTROL BMP.
  - WHEN SILT FENCE IS REMOVED, ALL DISTURBED AREAS SHALL BE COVERED WITH TOPSOIL, SEEDED AND MULCHED OR OTHERWISE STABILIZED AS APPROVED BY LOCAL JURISDICTION.
- (DETAIL ADAPTED FROM TOWN OF PARKER, COLORADO AND CITY OF AURORA, NOT AVAILABLE IN AUTOCAD)
- NOTE: MANY JURISDICTIONS HAVE BMP DETAILS THAT VARY FROM UDFCD STANDARD DETAILS. CONSULT WITH LOCAL JURISDICTIONS AS TO WHICH DETAIL SHOULD BE USED WHEN DIFFERENCES ARE NOTED.

SF-4 Urban Drainage and Flood Control District Urban Storm Drainage Criteria Manual Volume 3 November 2010

Stabilized Staging Area (SSA)

SM-6

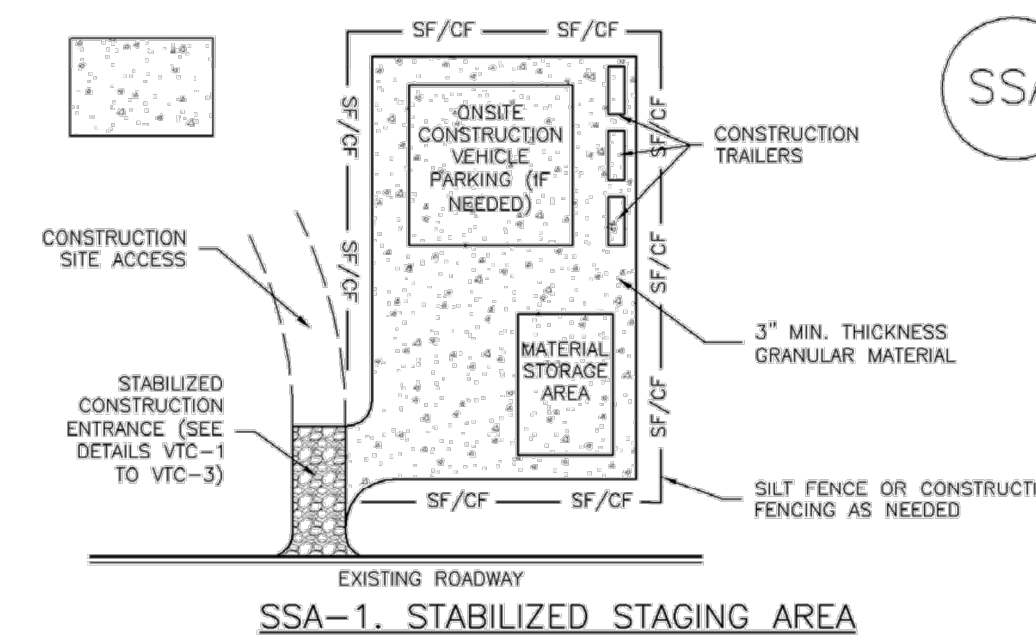

SSA-1. STABILIZED STAGING AREA

STABILIZED STAGING AREA INSTALLATION NOTES

- SEE PLAN VIEW FOR:
  - LOCATION OF STAGING AREA(S).
  - CONTRACTOR MAY ADJUST LOCATION AND SIZE OF STAGING AREA WITH APPROVAL FROM THE LOCAL JURISDICTION.
- STABILIZED STAGING AREA SHOULD BE APPROPRIATE FOR THE NEEDS OF THE SITE. OVERSIZING RESULTS IN A LARGER AREA TO STABILIZE FOLLOWING CONSTRUCTION.
- STAGING AREA SHALL BE STABILIZED PRIOR TO OTHER OPERATIONS ON THE SITE.
- THE STABILIZED STAGING AREA SHALL CONSIST OF A MINIMUM 3" THICK GRANULAR MATERIAL.
- UNLESS OTHERWISE SPECIFIED BY LOCAL JURISDICTION, ROCK SHALL CONSIST OF DOT SECT. #703, MSHTO #3 COARSE AGGREGATE OR 6" (MINUS) ROCK.
- ADDITIONAL PERIMETER BMPs MAY BE REQUIRED INCLUDING BUT NOT LIMITED TO SILT FENCE AND CONSTRUCTION FENCING.

STABILIZED STAGING AREA MAINTENANCE NOTES

- INSPECT BMPs EACH WORKDAY, AND MAINTAIN THEM IN EFFECTIVE OPERATING CONDITION. MAINTENANCE OF BMPs SHOULD BE PROACTIVE, NOT REACTIVE. INSPECT BMPs AS SOON AS POSSIBLE (AND ALWAYS WITHIN 24 HOURS) FOLLOWING A STORM THAT CAUSES SURFACE EROSION, AND PERFORM NECESSARY MAINTENANCE.
- FREQUENT OBSERVATIONS AND MAINTENANCE ARE NECESSARY TO MAINTAIN BMPs IN EFFECTIVE OPERATING CONDITION. INSPECTIONS AND CORRECTIVE MEASURES SHOULD BE DOCUMENTED THOROUGHLY.
- WHERE BMPs HAVE FAILED, REPAIR OR REPLACEMENT SHOULD BE INITIATED UPON DISCOVERY OF THE FAILURE.
- ROCK SHALL BE REAPPLIED OR REGRADED AS NECESSARY IF RUTTING OCCURS OR UNDERLYING SUBGRADE BECOMES EXPOSED.

November 2010 Urban Drainage and Flood Control District Urban Storm Drainage Criteria Manual Volume 3 SSA-3

SM-6

Stabilized Staging Area (SSA)

STABILIZED STAGING AREA MAINTENANCE NOTES

- STABILIZED STAGING AREA SHALL BE ENLARGED IF NECESSARY TO CONTAIN PARKING, STORAGE, AND UNLOADING/LOADING OPERATIONS.
  - THE STABILIZED STAGING AREA SHALL BE REMOVED AT THE END OF CONSTRUCTION. THE GRANULAR MATERIAL SHALL BE REMOVED OR, IF APPROVED BY THE LOCAL JURISDICTION, USED ON SITE, AND THE AREA COVERED WITH TOPSOIL, SEEDED AND MULCHED OR OTHERWISE STABILIZED IN A MANNER APPROVED BY LOCAL JURISDICTION.
- NOTE: MANY MUNICIPALITIES PROHIBIT THE USE OF RECYCLED CONCRETE AS GRANULAR MATERIAL FOR STABILIZED STAGING AREAS DUE TO DIFFICULTIES WITH RE-ESTABLISHMENT OF VEGETATION IN AREAS WHERE RECYCLED CONCRETE WAS PLACED.
- NOTE: MANY JURISDICTIONS HAVE BMP DETAILS THAT VARY FROM UDFCD STANDARD DETAILS. CONSULT WITH LOCAL JURISDICTIONS AS TO WHICH DETAIL SHOULD BE USED WHEN DIFFERENCES ARE NOTED.
- (DETAILS ADAPTED FROM DOUGLAS COUNTY, COLORADO, NOT AVAILABLE IN AUTOCAD)

SSA-4 Urban Drainage and Flood Control District Urban Storm Drainage Criteria Manual Volume 3 November 2010

Sediment Basin (SB)

SC-7

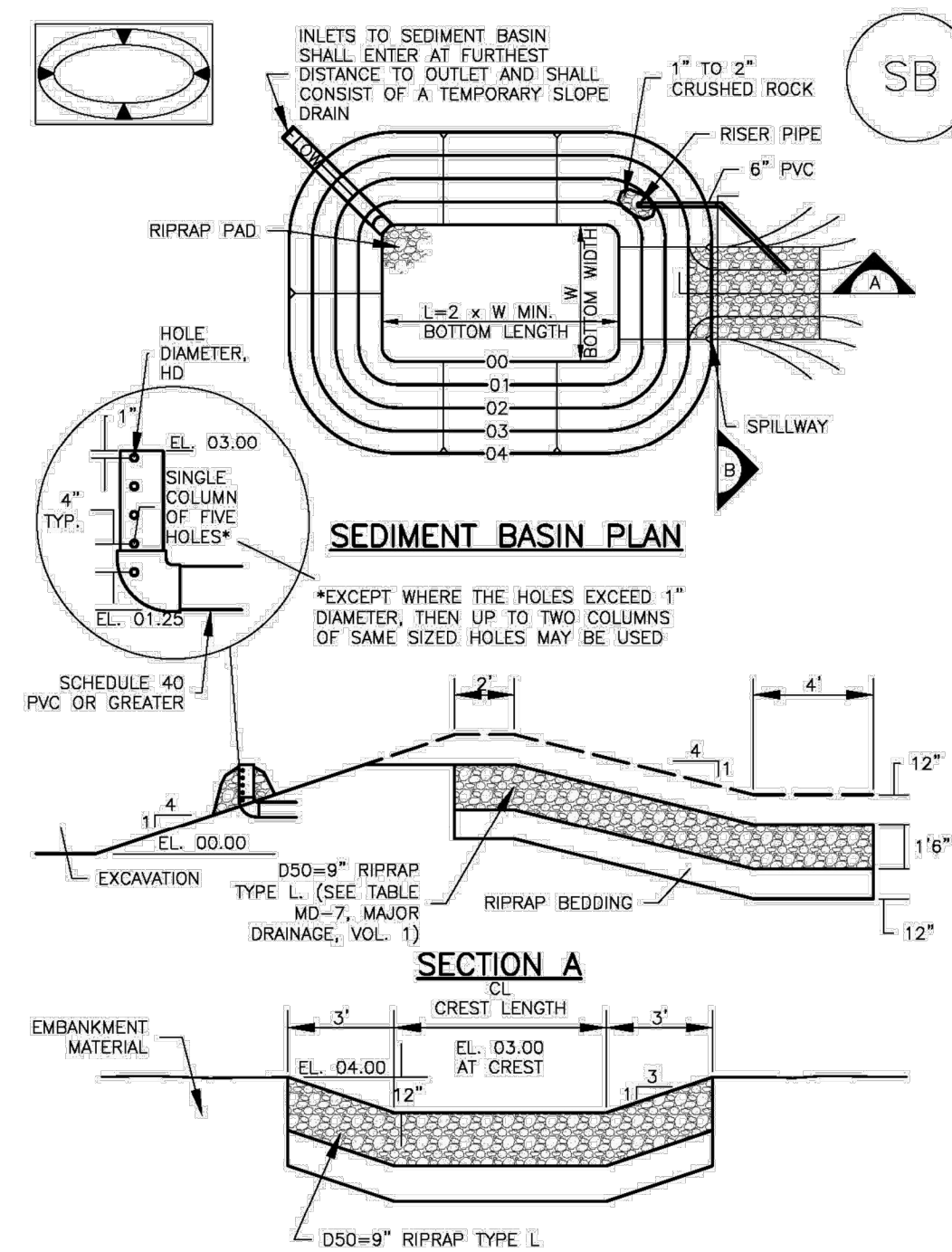

August 2013 Urban Drainage and Flood Control District Urban Storm Drainage Criteria Manual Volume 3 SB-5

SC-7

Sediment Basin (SB)

Upstream Drainage Area (rounded to nearest acre), (ac)	Basin Bottom Width (W), (ft)	Spillway Crest Length (CL), (ft)	Hole Diameter (HD), (in)
1	12 1/2	2	9/16
2	21	3	1 1/16
3	28	5	1 1/8
4	33 1/2	6	1 1/4
5	38 1/2	8	1 3/8
6	43	9	1 1/2
7	47 1/2	11	1 5/8
8	51	12	1 7/8
9	55	13	1 7/8
10	58 1/2	15	1 7/8
11	61	16	1 7/8
12	64	18	1 7/8
13	67 1/2	19	1 7/8
14	70 1/2	21	1 7/8
15	73 1/2	22	1 7/8

SEDIMENT BASIN INSTALLATION NOTES

- SEE PLAN VIEW FOR:
  - LOCATION OF SEDIMENT BASIN.
  - TYPE OF BASIN (STANDARD BASIN OR NONSTANDARD BASIN).
  - FOR STANDARD BASIN, BOTTOM WIDTH W, CREST LENGTH CL, AND HOLE DIAMETER, HD.
  - FOR NONSTANDARD BASIN, SEE CONSTRUCTION DRAWINGS FOR DESIGN OF BASIN INCLUDING RISER HEIGHT H, NUMBER OF COLUMNS N, HOLE DIAMETER HD AND PIPE DIAMETER D.
- FOR STANDARD BASIN, BOTTOM DIMENSION MAY BE MODIFIED AS LONG AS BOTTOM AREA IS NOT REDUCED.
- SEDIMENT BASINS SHALL BE INSTALLED PRIOR TO ANY OTHER LAND-DISTURBING ACTIVITY THAT RELIES ON ON BASINS AS A STORMWATER CONTROL.
- EMBANKMENT MATERIAL SHALL CONSIST OF SOIL FREE OF DEBRIS, ORGANIC MATERIAL, AND ROCKS OR CONCRETE GREATER THAN 3 INCHES AND SHALL HAVE A MINIMUM OF 15 PERCENT BY WEIGHT PASSING THE NO. 200 SIEVE.
- EMBANKMENT MATERIAL SHALL BE COMPACTED TO AT LEAST 95 PERCENT OF MAXIMUM DENSITY IN ACCORDANCE WITH ASTM D698.
- PIPE SCH 40 OR GREATER SHALL BE USED.
- THE DETAILS SHOWN ON THESE SHEETS PERTAIN TO STANDARD SEDIMENT BASIN(S) FOR DRAINAGE AREAS LESS THAN 15 ACRES. SEE CONSTRUCTION DRAWINGS FOR EMBANKMENT, STORAGE VOLUME, SPILLWAY, OUTLET, AND OUTLET PROTECTION DETAILS FOR ANY SEDIMENT BASIN(S) THAT HAVE BEEN INDIVIDUALLY DESIGNED FOR DRAINAGE AREAS LARGER THAN 15 ACRES.

SB-6 Urban Drainage and Flood Control District Urban Storm Drainage Criteria Manual Volume 3 August 2013

Sediment Basin (SB)

SC-7

SEDIMENT BASIN MAINTENANCE NOTES

- INSPECT BMPs EACH WORKDAY, AND MAINTAIN THEM IN EFFECTIVE OPERATING CONDITION. MAINTENANCE OF BMPs SHOULD BE PROACTIVE, NOT REACTIVE. INSPECT BMPs AS SOON AS POSSIBLE (AND ALWAYS WITHIN 24 HOURS) FOLLOWING A STORM THAT CAUSES SURFACE EROSION, AND PERFORM NECESSARY MAINTENANCE.
  - FREQUENT OBSERVATIONS AND MAINTENANCE ARE NECESSARY TO MAINTAIN BMPs IN EFFECTIVE OPERATING CONDITION. INSPECTIONS AND CORRECTIVE MEASURES SHOULD BE DOCUMENTED THOROUGHLY.
  - WHERE BMPs HAVE FAILED, REPAIR OR REPLACEMENT SHOULD BE INITIATED UPON DISCOVERY OF THE FAILURE.
  - SEDIMENT ACCUMULATED IN BASIN SHALL BE REMOVED AS NEEDED TO MAINTAIN BMP EFFECTIVENESS. TYPICALLY WHEN SEDIMENT DEPTH REACHES ONE FOOT (I.E., TWO FEET BELOW THE SPILLWAY CREST).
  - SEDIMENT BASINS ARE TO REMAIN IN PLACE UNTIL THE UPSTREAM DISTURBED AREA IS STABILIZED AND GRASS COVER IS ACCEPTED BY THE LOCAL JURISDICTION.
  - WHEN SEDIMENT BASINS ARE REMOVED, ALL DISTURBED AREAS SHALL BE COVERED WITH TOPSOIL, SEEDED AND MULCHED OR OTHERWISE STABILIZED AS APPROVED BY LOCAL JURISDICTION.
- (DETAILS ADAPTED FROM DOUGLAS COUNTY, COLORADO)
- NOTE: MANY JURISDICTIONS HAVE BMP DETAILS THAT VARY FROM UDFCD STANDARD DETAILS. CONSULT WITH LOCAL JURISDICTIONS AS TO WHICH DETAIL SHOULD BE USED WHEN DIFFERENCES ARE NOTED.

August 2013 Urban Drainage and Flood Control District Urban Storm Drainage Criteria Manual Volume 3 SB-7

**811**  
Know what's below.  
Call before you dig.

THE LOCATIONS OF EXISTING UNDERGROUND UTILITIES ARE SHOWN IN AN APPROXIMATE WAY ONLY AND HAVE NOT BEEN INDEPENDENTLY VERIFIED BY THE CONTRACTOR. THE CONTRACTOR SHALL DETERMINE THE EXACT LOCATION OF ALL EXISTING UTILITIES BEFORE COMMENCING WORK, AND AGREES TO BE FULLY RESPONSIBLE FOR ANY AND ALL DAMAGES WHICH MIGHT BE OCCASIONED BY THE CONTRACTOR'S FAILURE TO EXACTLY LOCATE AND PRESERVE ANY AND ALL UNDERGROUND UTILITIES.

NOTE: CONSTRUCTION SITE SAFETY IS THE SOLE RESPONSIBILITY OF THE CONTRACTOR. NEITHER THE OWNER NOR THE ENGINEER SHALL BE RESPONSIBLE FOR SAFETY OF THE WORK OF PERSONS ENGAGED IN THE WORK, OF ANY NEARBY STRUCTURES, OR OF ANY OTHER PERSONS.

NOTE: MANY MUNICIPALITIES PROHIBIT THE USE OF RECYCLED CONCRETE AS GRANULAR MATERIAL FOR STABILIZED STAGING AREAS DUE TO DIFFICULTIES WITH RE-ESTABLISHMENT OF VEGETATION IN AREAS WHERE RECYCLED CONCRETE WAS PLACED.

NOTE: MANY JURISDICTIONS HAVE BMP DETAILS THAT VARY FROM UDFCD STANDARD DETAILS. CONSULT WITH LOCAL JURISDICTIONS AS TO WHICH DETAIL SHOULD BE USED WHEN DIFFERENCES ARE NOTED.

(DETAILS ADAPTED FROM DOUGLAS COUNTY, COLORADO, NOT AVAILABLE IN AUTOCAD)

COPYRIGHT © 2022 ATWELL LLC. NO REPRODUCTION SHALL BE MADE WITHOUT THE PRIOR WRITTEN CONSENT OF ATWELL LLC.

**ATWELL**  
866.850.4200 www.atwell-group.com  
143 UNION BOULEVARD, SUITE 700  
LAKEWOOD, CO 80228  
303.462.1100

CHALLENGER HOMES  
8605 EXPLORER DRIVE  
SUITE 250  
COLORADO SPRINGS, CO 80920  
719-598-5192  
JIM BYERS

CHALLENGER HOMES  
FALCON HIGHLANDS SOUTH  
EL PASO COUNTY, COLORADO  
CONSTRUCTION PLANS  
GRADING AND EROSION CONTROL PLAN  
DETAIL G/CP

CLIENT  
DATE 8/31/2022  
SUBMITTAL TO EPC 07/29/2022 - RDL

COUNTY FILE NO.: PUDSP-22-005  
DR. JD CH.  
P.M. RDL  
JOB 21005234  
SHEET NO. 16





Know what's below.  
Call before you dig.

THE LOCATIONS OF EXISTING UNDERGROUND UTILITIES ARE SHOWN IN AN APPROXIMATE WAY ONLY AND HAVE NOT BEEN INDEPENDENTLY VERIFIED BY THE OWNER OR ITS REPRESENTATIVE. THE CONTRACTOR SHALL DETERMINE THE EXACT LOCATION OF ALL EXISTING UTILITIES BEFORE COMMENCING WORK, AND AGREES TO BE FULLY RESPONSIBLE FOR ANY AND ALL DAMAGES WHICH MIGHT BE OCCASIONED BY THE CONTRACTOR'S FAILURE TO EXACTLY LOCATE AND PRESERVE ANY AND ALL UNDERGROUND UTILITIES.

NOTICE: CONSTRUCTION SITE SAFETY IS THE SOLE RESPONSIBILITY OF THE CONTRACTOR. NEITHER THE OWNER NOR THE ENGINEER SHALL BE EXPECTED TO ASSUME ANY RESPONSIBILITY FOR SAFETY OF THE WORK OF PERSONS ENGAGED IN THE WORK, OF ANY NEARBY STRUCTURES, OR OF ANY OTHER PERSONS.

COPYRIGHT © 2022 ATWELL LLC. NO REPRODUCTION SHALL BE MADE WITHOUT THE PRIOR WRITTEN CONSENT OF ATWELL LLC.

**ATWELL**  
www.atwell-group.com  
866.850.4200  
143 UNION BOULEVARD, SUITE 700  
LAKEWOOD, CO 80228  
303.462.1100



**CHALLENGER HOMES**  
8605 EXPLORER DRIVE  
SUITE 250  
COLORADO SPRINGS, CO 80920  
719-598-5192  
JIM BYERS

**CHALLENGER HOMES**  
FALCON HIGHLANDS SOUTH  
EL PASO COUNTY, COLORADO  
CONSTRUCTION PLANS  
GRADING AND EROSION CONTROL PLAN  
DETAIL GECP

CLIENT  
DATE 8/31/2022

A 1st SUBMITTAL TO EPIC  
07/29/2022 - RDL

NO.	REVISIONS

COUNTY FILE NO.:  
PUDSP-22-005

DR. JD CH.  
P.M. RDL

JOB 21005234  
SHEET NO. 17

CAD FILE: 21005234-GECP-DETAILS.DWG

Inlet Protection (IP) SC-6

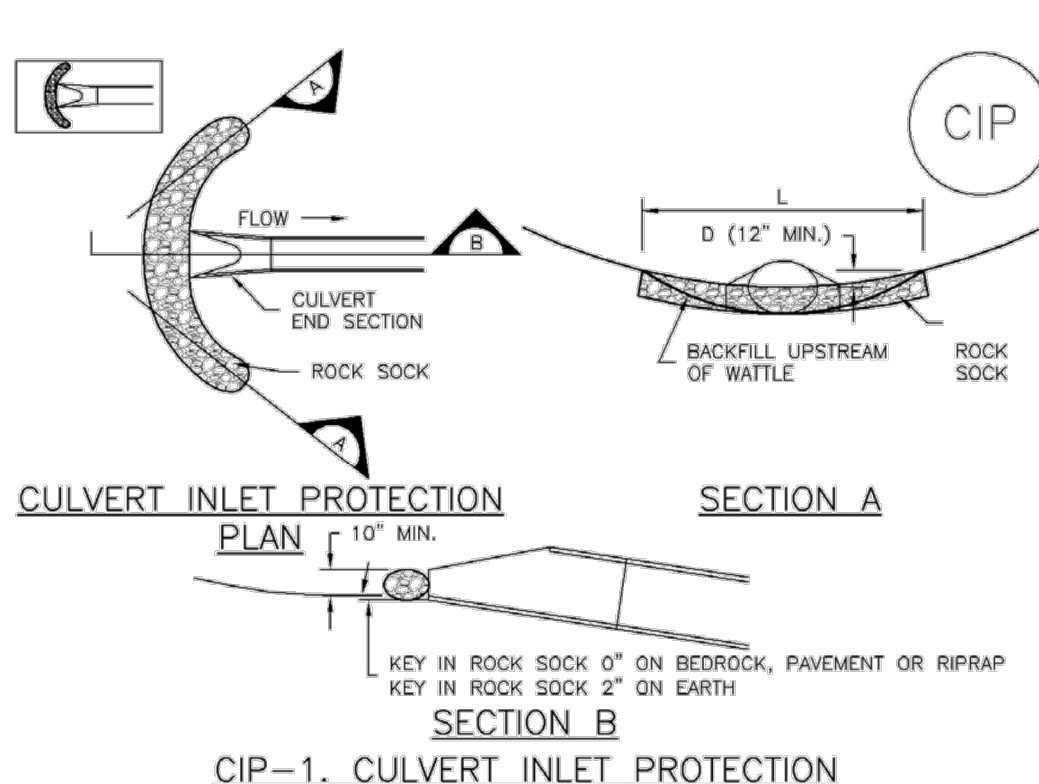

CIP-1. CULVERT INLET PROTECTION

- CULVERT INLET PROTECTION INSTALLATION NOTES**
1. SEE PLAN VIEW FOR LOCATION OF CULVERT INLET PROTECTION.
  2. SEE ROCK SOCK DESIGN DETAIL FOR ROCK GRADATION REQUIREMENTS AND JOINTING DETAIL.
- CULVERT INLET PROTECTION MAINTENANCE NOTES**
1. INSPECT BMPs EACH WORKDAY, AND MAINTAIN THEM IN EFFECTIVE OPERATING CONDITION. MAINTENANCE OF BMPs SHOULD BE PROACTIVE, NOT REACTIVE. INSPECT BMPs AS SOON AS POSSIBLE (AND ALWAYS WITHIN 24 HOURS) FOLLOWING A STORM THAT CAUSES SURFACE EROSION, AND PERFORM NECESSARY MAINTENANCE.
  2. FREQUENT OBSERVATIONS AND MAINTENANCE ARE NECESSARY TO MAINTAIN BMPs IN EFFECTIVE OPERATING CONDITION. INSPECTIONS AND CORRECTIVE MEASURES SHOULD BE DOCUMENTED THOROUGHLY.
  3. WHERE BMPs HAVE FAILED, REPAIR OR REPLACEMENT SHOULD BE INITIATED UPON DISCOVERY OF THE FAILURE.
  4. SEDIMENT ACCUMULATED UPSTREAM OF THE CULVERT SHALL BE REMOVED WHEN THE SEDIMENT DEPTH IS 1/2 THE HEIGHT OF THE ROCK SOCK.
  5. CULVERT INLET PROTECTION SHALL REMAIN IN PLACE UNTIL THE UPSTREAM DISTURBED AREA IS PERMANENTLY STABILIZED AND APPROVED BY THE LOCAL JURISDICTION.
- (DETAILS ADAPTED FROM AURORA, COLORADO, NOT AVAILABLE IN AUTOCAD)  
NOTE: MANY JURISDICTIONS HAVE BMP DETAILS THAT VARY FROM UDFCD STANDARD DETAILS. CONSULT WITH LOCAL JURISDICTIONS AS TO WHICH DETAIL SHOULD BE USED WHEN DIFFERENCES ARE NOTED.

August 2013 Urban Drainage and Flood Control District Urban Storm Drainage Criteria Manual Volume 3 IP-7

Inlet Protection (IP) SC-6

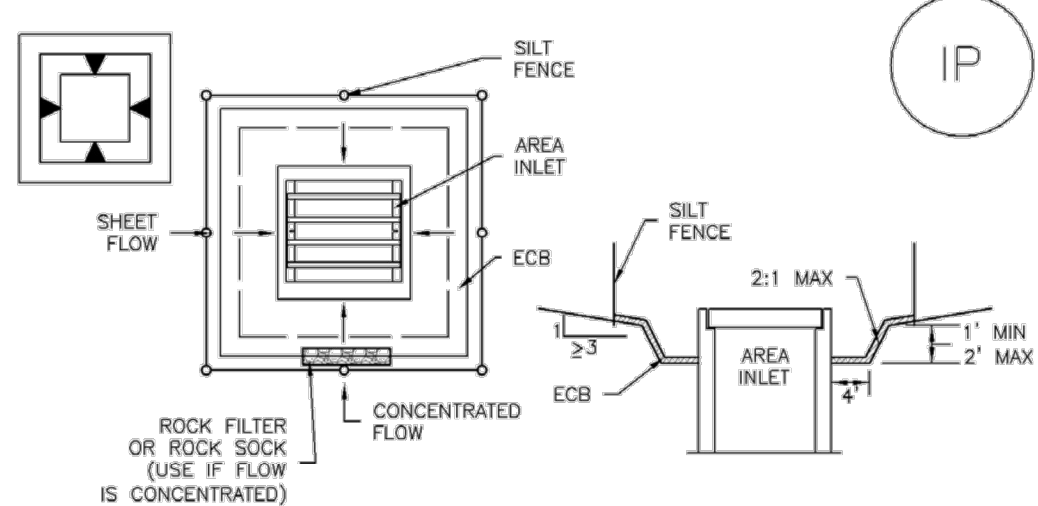

IP-5. OVEREXCAVATION INLET PROTECTION

- OVEREXCAVATION INLET PROTECTION INSTALLATION NOTES**
1. THIS FORM OF INLET PROTECTION IS PRIMARILY APPLICABLE FOR SITES THAT HAVE NOT YET REACHED FINAL GRADE AND SHOULD BE USED ONLY FOR INLETS WITH A RELATIVELY SMALL CONTRIBUTING DRAINAGE AREA.
  2. WHEN USING FOR CONCENTRATED FLOWS, SHAPE BASIN IN 2:1 RATIO WITH LENGTH ORIENTED TOWARDS DIRECTION OF FLOW.
  3. SEDIMENT MUST BE PERIODICALLY REMOVED FROM THE OVEREXCAVATED AREA.

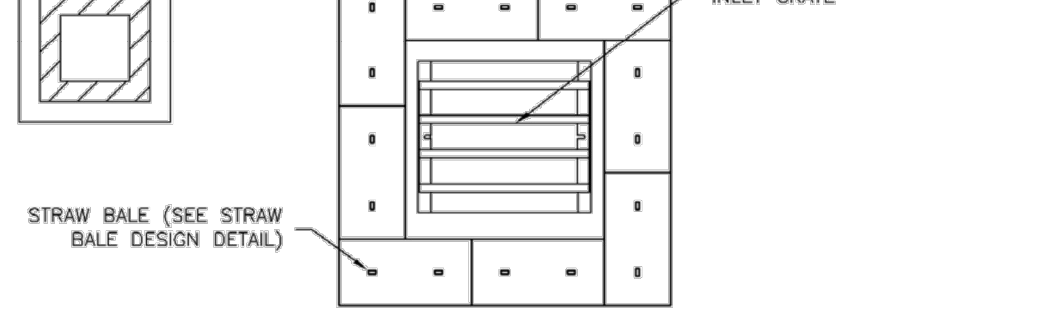

IP-6. STRAW BALE FOR SUMP INLET PROTECTION

- STRAW BALE BARRIER INLET PROTECTION INSTALLATION NOTES**
1. SEE STRAW BALE DESIGN DETAIL FOR INSTALLATION REQUIREMENTS.
  2. BALES SHALL BE PLACED IN A SINGLE ROW AROUND THE INLET WITH ENDS OF BALES TIGHTLY ABUTTING ONE ANOTHER.

August 2013 Urban Drainage and Flood Control District Urban Storm Drainage Criteria Manual Volume 3 IP-6

Inlet Protection (IP) SC-6

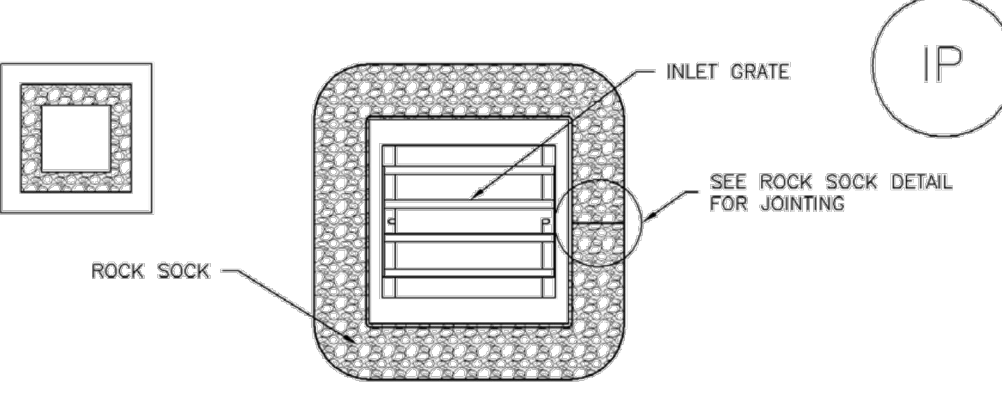

IP-3. ROCK SOCK SUMP/AREA INLET PROTECTION

- ROCK SOCK SUMP/AREA INLET PROTECTION INSTALLATION NOTES**
1. SEE ROCK SOCK DESIGN DETAIL FOR INSTALLATION REQUIREMENTS.
  2. STRAW WATTLES/SEDIMENT CONTROL LOGS MAY BE USED IN PLACE OF ROCK SOCKS FOR INLETS IN PERVIOUS AREAS. INSTALL PER SEDIMENT CONTROL LOG DETAIL.

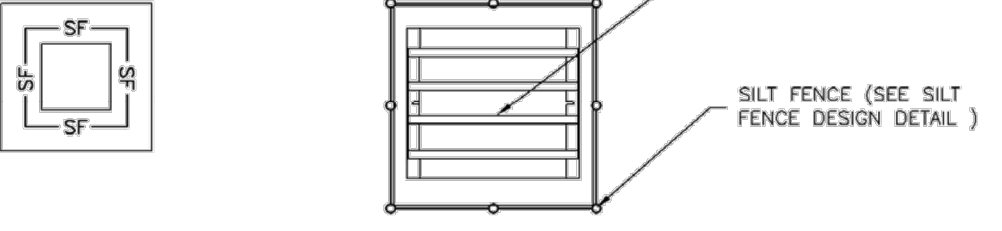

IP-4. SILT FENCE FOR SUMP INLET PROTECTION

- SILT FENCE INLET PROTECTION INSTALLATION NOTES**
1. SEE SILT FENCE DESIGN DETAIL FOR INSTALLATION REQUIREMENTS.
  2. POSTS SHALL BE PLACED AT EACH CORNER OF THE INLET AND AROUND THE EDGES AT A MAXIMUM SPACING OF 3 FEET.
  3. STRAW WATTLES/SEDIMENT CONTROL LOGS MAY BE USED IN PLACE OF SILT FENCE FOR INLETS IN PERVIOUS AREAS. INSTALL PER SEDIMENT CONTROL LOG DETAIL.

August 2013 Urban Drainage and Flood Control District Urban Storm Drainage Criteria Manual Volume 3 IP-5

Inlet Protection (IP) SC-6

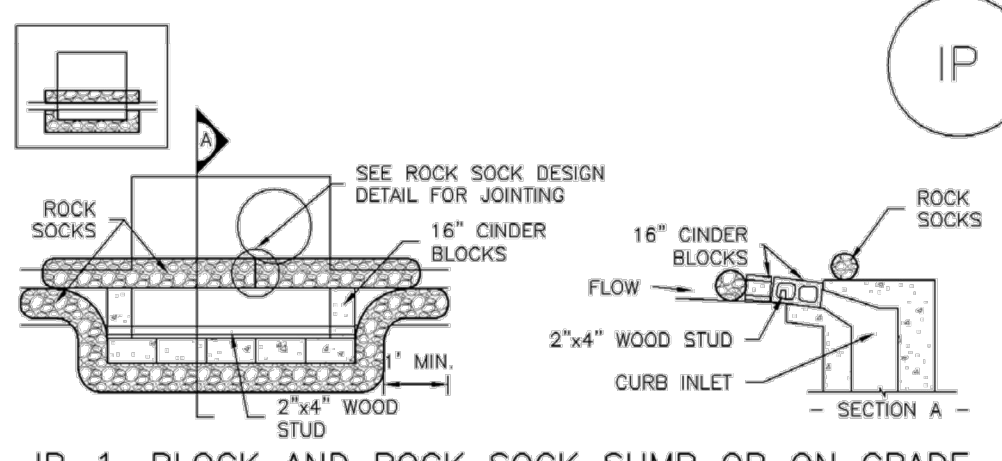

IP-1. BLOCK AND ROCK SOCK SUMP OR ON-GRADE INLET PROTECTION

- BLOCK AND CURB SOCK INLET PROTECTION INSTALLATION NOTES**
1. SEE ROCK SOCK DESIGN DETAIL FOR INSTALLATION REQUIREMENTS.
  2. CONCRETE "CINDER" BLOCKS SHALL BE LAID ON THEIR SIDES AROUND THE INLET IN A SINGLE ROW, ABUTTING ONE ANOTHER WITH THE OPEN END FACING AWAY FROM THE CURB.
  3. DRAWL BARS SHALL BE PLACED AROUND CONCRETE BLOCKS, CLOSELY ABUTTING ONE ANOTHER AND JOINTED TOGETHER IN ACCORDANCE WITH ROCK SOCK DESIGN DETAIL.

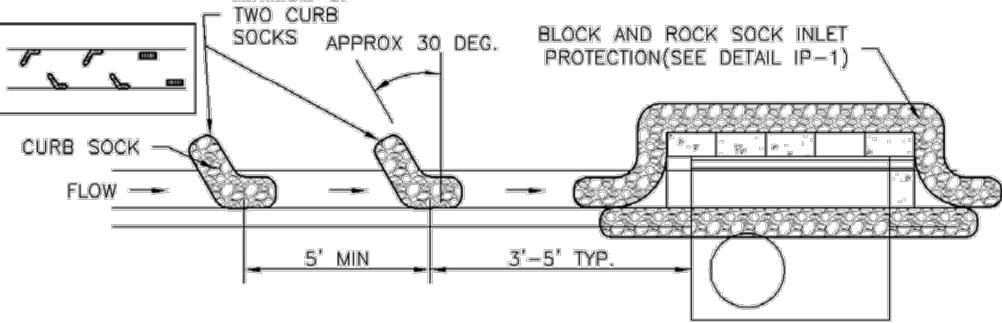

IP-2. CURB ROCK SOCKS UPSTREAM OF INLET PROTECTION

- CURB ROCK SOCK INLET PROTECTION INSTALLATION NOTES**
1. SEE ROCK SOCK DESIGN DETAIL INSTALLATION REQUIREMENTS.
  2. PLACEMENT OF THE SOCK SHALL BE APPROXIMATELY 30 DEGREES FROM PERPENDICULAR IN THE OPPOSITE DIRECTION OF FLOW.
  3. SOCKS ARE TO BE FLUSH WITH THE CURB AND SPACED A MINIMUM OF 5 FEET APART.
  4. AT LEAST TWO CURB SOCKS IN SERIES ARE REQUIRED UPSTREAM OF ON-GRADE INLETS.

August 2013 Urban Drainage and Flood Control District Urban Storm Drainage Criteria Manual Volume 3 IP-4